

# Drawings

## 96062 Clamp-on Probe

Unit: mm  
(approx. inch)

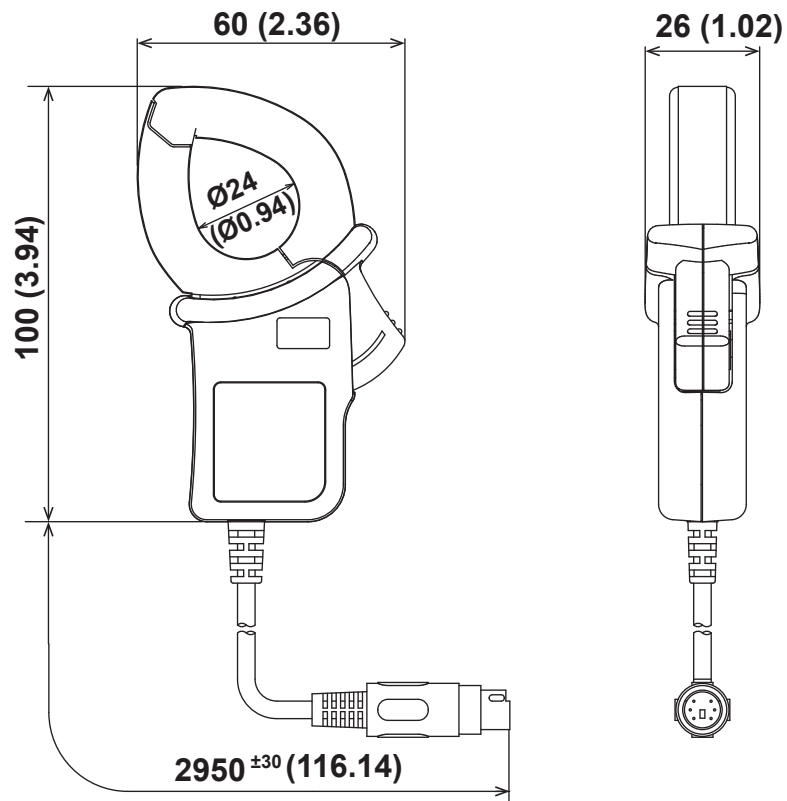

Weight : approx. 160 g

If not specified, the tolerance is  $\pm 3\%$ . However, in cases of less than 10 mm, the tolerance is  $\pm 0.3$  mm.