

1. Checking the Parts in the Kit

Confirm that all parts listed below are included in the kit. If any part is shorted or any abnormality is found in the appearance of the parts, contact our sales representative where you bought the instrument.

List of parts included in the kit.

left side bracket (1 pc), right side bracket (1 pc), flat-head screws (M5, 14 mm long) (3 pcs), binding-head screw (M5, 14 mm long) (3 pcs), sealing labels (6 pcs)

2. Joining the Instruments with Mounting Hardware

Removing the Handle

Note: There is a chance that the handle cannot be reattached once it has been removed from the instrument.

1. Remove the two covers (a) from the handle by firmly inserting a screwdriver in the direction of the two arrows marked (A). If the covers stick to the handle, use another tool to widen the opening of each cover horizontally and then retry taking off the cover.
2. To remove the handle, unscrew the two screws (b) which fix the handle to the instrument.

Removing the Feet on the Bottom

1. When a black pin (g) is included in each foot (c), pry out the four pins with a thin screwdriver as shown in the figure below.
2. Press each foot (c) in the direction of arrow (B), that is, toward the rear of the instrument, to slide off the four feet (c).
3. Press each foot (c) in the direction of arrow (C), that is, downward, to remove the four feet (c).
After the front feet (c) are removed, the support hardware (d) is also detached.

Removing the Sealing Labels

1. Remove the four sealing labels (e).
2. Unplug the two blind plugs (f).

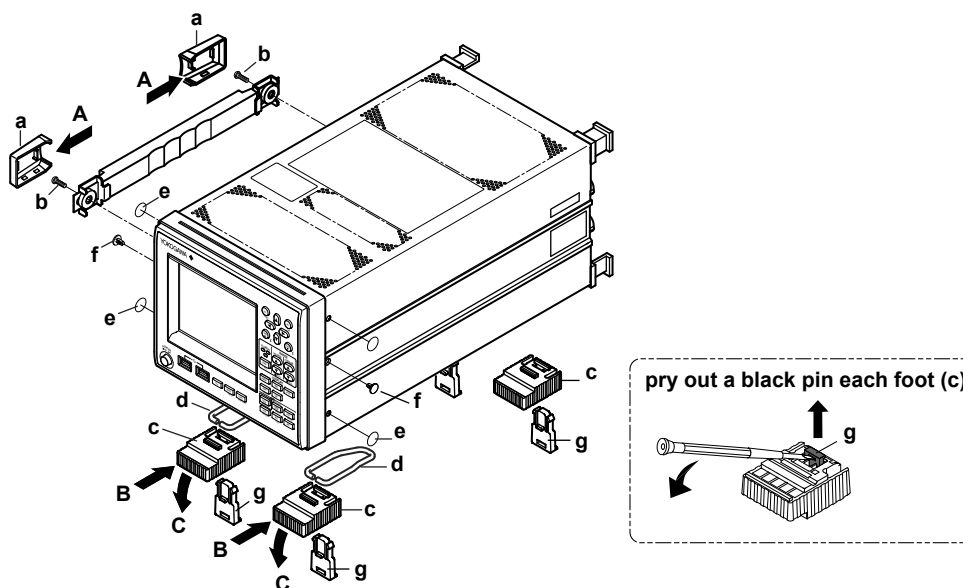

3. Joining the Right and Left Instruments with Mounting Hardware

1. With the six labels (1), seal the six openings on the bottom plate to fix the feet and the left side panel to fix the handle.
2. Using three flat-head screws (M5, 14 mm long) (3), screw the left side bracket (2) to the left side of the instrument.
Reference torque value: 2.8 to 2.9 N•m
3. Using three binding-head screws (M5, 14 mm long) (5), screw the right side bracket (4) to the right side of the instrument.
Reference torque value: 2.8 to 2.9 N•m

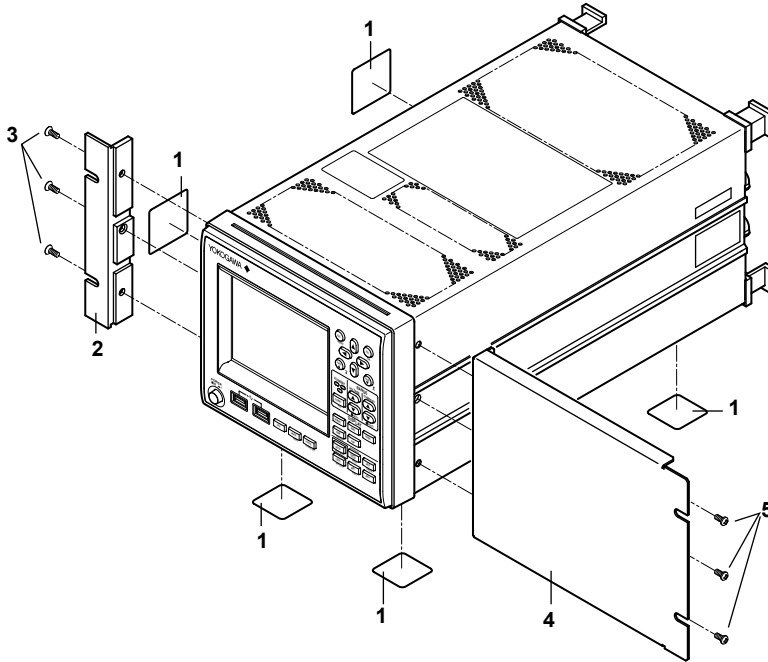

4. Mounting the Joined Instruments to the Rack

Dimensions after mounting to the rack are illustrated below.

Note:

1. Be sure to support the instrument from the bottom. When doing so, make sure not to cover the ventilation holes on the bottom of the instrument.
2. Provide a clearance of at least 80 mm around the instrument to prevent the temperature rise inside the instrument.

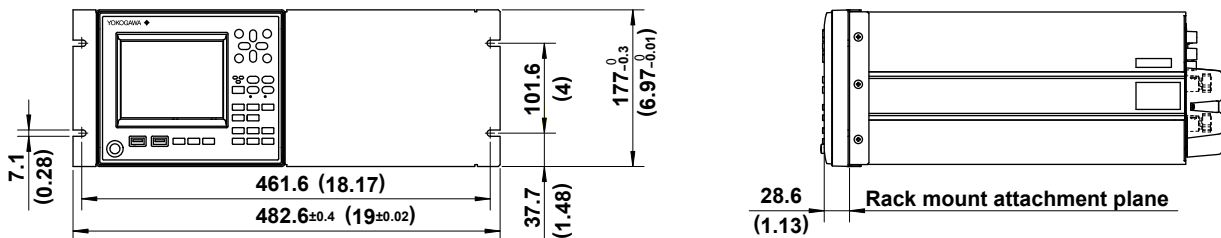

If not specified, the tolerance is ±3%. However, in cases of less than 10 mm, the tolerance is ±0.3 mm.