Operation Guide



Model 436101/436102/436103/436104/436106

μR10000 Recorder

User Registration Request

Thank you for purchasing YOKOGAWA products.

Please register to the following Customer Portal Member Site.
You can use various services such as confirmation of purchased product information,
download of related materials, and newsletter.

<https://myportal.yokogawa.com/>

Contents

Introduction	4
⚠ Safety Precautions	4
Handling Precautions	6
SD Memory Card Handling Precautions	6
How to Use This Manual	7
Checking the Contents of the Package	7
Recorder Style Number, Release Number, and Firmware Version Number	8
Removing the Packing Materials	8
Recorder's Version and Functions Described in This Manual	9
Protection of Environment	10
Function Introduction/Names of Parts	11
Function Introduction	11
Names of Parts	12
Display and Key Panel	13
Installing/Wiring the Recorder	14
Installation Location	14
Installation Procedure	14
⚠ Input Signal Wiring	17
⚠ Optional Terminal Wiring	19
⚠ Power Supply Wiring	21
Common Operations and Menu Structure	23
Execution Modes	23
Operation Sequence	23
Key Operation	24
Menu Structure of Setting Mode	27
Menu Structure of Basic Setting Mode	28
Preparing to Record	29
Loading or Replacing the Chart Paper	29
Installing/Replacing Felt Pens (Pen Model)	31
Installing/Replacing the Plotter Pen (Pen Model)	32
Installing/Replacing the Ribbon Cassette (Dot Model)	32
Checking or Setting the Date/Time	34
Setting the Input Range and Alarm on Measurement Channels	35
Setup Example (1) of Thermocouple Input	35
Setup Example (2) of 1-5V Input and unit	36
Setup Example (3) of 0 to 10 V Input	38
Setting the Alarm	41
Recording/Displaying Data	43
Starting the Recording	43
Stopping the Recording	43
Feeding the Chart Paper Manually	43
Changing the Chart Speed	44
Viewing the Recorded Results	44
Description of the Printout Contents	45
Switching the Display Screen	47
Changing the Displayed Information	48
FUNC Key Operations in Operation Mode	49
Printing Measured Values (Manual Printout)	49
Printing the Recorder Settings	50
Clearing the Alarm Printout Buffer	51
Printing a Message	51
Releasing the Alarm Output (Alarm ACK Operation)	52
Activating/Releasing the Key Lock	52
Setup Items and Default Values	53
Setup Items in Setting Mode and Their Default Values	53
Setup Items in Basic Setting Mode and Their Default Values	55
Recommended Replacement Periods for Worn Parts	58

For detailed explanation of functions and the operating procedures of the recorder, see the *μR10000 Recorder User's Manual (IM 04P01B01-01E)*.

Introduction

Thank you for purchasing the YOKOGAWA μ R10000 Recorder. This manual describes concisely the operating procedures of the μ R10000 Recorder. To ensure correct use, please read this manual and the following manuals thoroughly before beginning operation. For the product specifications, see the general specifications.

Paper Manuals

Manual Title	Manual No.*
μ R10000 Recorder Operation Guide	IM 04P01B01-02E (this manual)
μ R10000 / μ R20000 Usage Precautions ¹	IM 04P01B01-93E

¹ Only delivered when the Operation Guide is not included.

Electronic Manuals

You can download these manuals from the following web page. You will need Adobe Reader 7 or later (latest version recommended) by Adobe Systems.

<http://www.yokogawa.com/ns/mr/im/>

Manual Title	Manual No.*
μ R10000 Recorder Operation Guide	IM 04P01B01-02E
μ R10000 Recorder User's Manual	IM 04P01B01-01E
μ R10000/ μ R20000 Communication Interface User's Manual	IM 04P01B01-17E
μ R10000/ μ R20000 SD Memory Card (EM1 option) User's Manual	IM 04P01B01-03E
RXA10-01 and RXA10-02 Configuration Software User's Manual (sold separately)	IM 04P01B01-61E

General Specifications (GS)

General Specifications Name	General Specifications No.*
μ R10000 Recorder	GS04P01B01-01E

* The last character of the manual number and general specifications number indicates the language in which the manual is written.

Notes

- The contents of this manual are subject to change without prior notice as a result of continuing improvements to the instrument's performance and functions.
- Every effort has been made in the preparation of this manual to ensure the accuracy of its contents. However, should you have any questions or find any errors, please contact your nearest YOKOGAWA dealer as listed on the back cover of this manual.
- Copying or reproducing all or any part of the contents of this manual without the permission of Yokogawa Electric Corporation is strictly prohibited.
- This manual is part of this product. Keep this manual on safe place for future reference.
- The TCP/IP software of this product and the document concerning the TCP/IP software have been developed/created by YOKOGAWA based on the BSD Networking Software, Release 1 that has been licensed from the University of California.

QR Code

The product has a QR Code pasted for efficient plant maintenance work and asset information management.

It enables confirming the specifications of purchased products and user's manuals.

For more details, please refer to the following URL.

<https://www.yokogawa.com/qr-code>

QR Code is a registered trademark of DENSO WAVE INCORPORATED.

About the Usage of Open Source Software

MD5

The following products uses MD5 source code.

In accordance with the MD5 license agreement, the copyright notice, redistribution conditions, and license are listed below.

436101, 436102, 436103, 436104, 436106

- RSA Data Security's MD5 License

RSA Data Security, Inc., MD5 message-digest algorithm
Copyright (C) 1991-2, RSA Data Security, Inc. Created 1991. All rights reserved.

License to copy and use this software is granted provided that it is identified as the "RSA Data Security, Inc. MD5 Message-Digest Algorithm" in

14th Edition: August 2023 (YK)

All Rights Reserved, Copyright © 2004, Yokogawa Electric Corporation

all material mentioning or referencing this software or this function.

License is also granted to make and use derivative works provided that such works are identified as "derived from the RSA Data Security, Inc. MD5 Message-Digest Algorithm" in all material mentioning or referencing the derived work.

RSA Data Security, Inc. makes no representations concerning either the merchantability of this software or the suitability of this software for any particular purpose. It is provided "as is" without express or implied warranty of any kind.

These notices must be retained in any copies of any part of this documentation and/or software.

Trademarks

- All the brands or names of Yokogawa Electric's products used in this manual are either trademarks or registered trademarks of Yokogawa Electric Corporation.
- Microsoft and Windows are either registered trademarks or trademarks of Microsoft Corporation in the United States and/or other countries.
- Adobe, Acrobat, and PostScript are trademarks of Adobe Systems Incorporated.
- The SD logo is a registered trademark of the SD association.
- For purposes of this manual, the TM and © symbols do not accompany their respective trademark names or registered trademark names.
- Company and product names that appear in this manual are trademarks or registered trademarks of their respective holders.

Revisions

1st Edition	December	2nd Edition	March 2005
3rd Edition	August 2005	4th Edition	September 2006
5th Edition	April 2011	6th Edition	March 2015
7th Edition	July 2017	8th Edition	June 2018
9th Edition	September 2018	10th Edition	February 2020
11th Edition	June 2020	12th Edition	February 2021
13th Edition	November 2022	14th Edition	August 2023

Authorised Representative in the EEA and the Importer into the EU/EEA Market

The Authorised Representative for this product in the EEA and the importer for this product into the EU/EEA market via Yokogawa sales channel is:

Yokogawa Europe B.V.

Euroweg 2, 3825 HD Amersfoort, The Netherlands

Importer for This Product into the Great Britain Market

In relation to UKCA marking, the importer for this product into the Great Britain market via the YOKOGAWA sales channel is:

Yokogawa United Kingdom Limited

Stuart Road Manor Park Runcorn, WA7 1TR, United Kingdom

Safety Precautions

The general safety precautions described here must be observed during all phases of operation.

Safety Standards and EMC Standards

This recorder conforms to IEC safety class I (provided with terminal for protective grounding), Overvoltage Category II or I, Pollution Degree 2, Measurement Category II (CAT II), and EN 61326-1 (EMC standard) class A (use in a commercial, industrial, or business environment). The influence rate (judgment condition A) in the immunity test environment is within ± 10 % of the range.

This recorder is designed for indoor use.

CSA CAN/CSA-C22.2 No. 61010-1,
CAN/CSA-C22.2 No. 61010-2-030
Overvoltage Category II or I¹, Pollution Degree 2²,
Measurement Category II³

UL UL 61010-1, UL 61010-2-030 (CSA NRTL/C)
Overvoltage Category II or I¹, Pollution Degree 2²,
Measurement Category II³

CE, UKCA

EMC directive:

EN 61326-1 Class A, Table 2 (For use in industrial locations) compliant

EN 61000-3-2 compliant, EN IEC 61000-3-2 compliant

EN 61000-3-3 compliant,

EN 55011 Class A Group 1 compliant

Low voltage directive:

EN 61010-1, EN IEC 61010-2-030 compliant

Overvoltage Category II or I¹, Pollution Degree 2², Measurement Category II³

EU RoHS directive: EN IEC 63000 compliant

WEEE Directive: Compliant

EMC Regulatory Arrangement in Australia and New Zealand(RCM):

EN 55011 Class A Group 1 compliant

KC marking: KS C9811, KS C9610-6-2 compliant

*1 Overvoltage Category

Describes a number which defines a transient overvoltage condition. It implies the regulation for impulse withstand voltage. Applies to electrical equipment which is supplied from fixed installations like distribution boards.

II: Applied to standard power supply (100 - 240 VAC)

I: Applied to /P1 option (24 VDC/AC)

*2 Pollution Degree

Describes the degree to which a solid, liquid, or gas which deteriorates dielectric strength or surface resistivity is adhering.

"2" applies to normal indoor atmosphere.

Normally, only non-conductive pollution occurs.

*3 Measurement Category II (CAT II)

Applies to measuring circuits connected to low voltage installation, and electrical instruments supplied with power from fixed equipment such as electric switchboards.

• **About This Manual**

- This manual should be read by the end user.
- Read this manual thoroughly and have a clear understanding of the product before operation.
- This manual explains the functions of the product. YOKOGAWA does not guarantee that the product will suit a particular purpose of the user.
- Under absolutely no circumstances may the contents of this manual be transcribed or copied, in part or in whole, without permission.
- The contents of this manual are subject to change without prior notice.
- Every effort has been made in the preparation of this manual to ensure the accuracy of its contents. However, should you have any questions or find any errors or omissions, please contact your nearest YOKOGAWA dealer.

• **Precautions Related to the Protection, Safety, and Alteration of the Product**

- The following safety symbols are used on the product and in this manual.



"Handle with care." To avoid injury and damage to the instrument, the operator must refer to the explanation in the manual.



Protective ground terminal



AC



DC



"High temperature." To avoid injury caused by hot surface, do not touch locations where this symbol appears.

- For the protection and safe use of the product and the system controlled by it, be sure to follow the instructions and precautions on safety that are stated in this manual whenever you handle the product. Take special note that if you handle the product in a manner that violate these instructions, the protection functionality of the product may be damaged or impaired. In such cases, YOKOGAWA does not guarantee the quality, performance, function, and safety of the product.
- When installing protection and/or safety circuits such as lightning protection devices and equipment for the product and control system or designing or installing separate protection and/or safety circuits for fool-proof design and fail-safe design of the processes

and lines that use the product and the control system, the user should implement these using additional devices and equipment.

- If you are replacing parts or consumable items of the product, make sure to use parts specified by YOKOGAWA.
- This product is not designed or manufactured to be used in critical applications that directly affect or threaten human lives. Such applications include nuclear power equipment, devices using radioactivity, railway facilities, aviation equipment, air navigation facilities, aviation facilities, and medical equipment. If so used, it is the user's responsibility to include in the system additional equipment and devices that ensure personnel safety.
- Do not modify this product.



WARNING

- **Use the Correct Power Supply**
Ensure that the source voltage matches the voltage of the power supply before turning ON the power.
- **Protective Grounding**
Make sure to connect the protective grounding to prevent electric shock before turning ON the power.
- **Necessity of Protective Grounding**
Never cut off the internal or external protective earth wire or disconnect the wiring of the protective earth terminal. Doing so invalidates the protective functions of the instrument and poses a potential shock hazard.
- **Defect of Protective Grounding**
Do not operate the instrument if the protective earth or fuse might be defective. Make sure to check them before operation.
- **Do Not Operate in an Explosive Atmosphere**
Do not operate the instrument in the presence of flammable liquids or vapors. Operation in such environments constitutes a safety hazard.
- **Do Not Remove Covers**
The cover should be removed by YOKOGAWA's qualified personnel only. Opening the cover is dangerous, because some areas inside the instrument have high voltages.
- **External Connection**
Connect the protective grounding before connecting to the item under measurement or to an external control unit.
- **Damage to the Protective Structure**
Operating the recorder in a manner not described in this manual may damage its protective structure.

Portable Type (/H5x Option)

- **Use the Correct Power Supply**
Ensure that the power supply is within the maximum rated voltage range of the provided power cord before connecting the power cord.
- **Use the Correct Power Cord and Plug**
To prevent electric shock or fire, be sure to use the power cord supplied by YOKOGAWA. The main power plug must be plugged into an outlet with a protective earth terminal. Do not disable this protection by using an extension cord without protective earth grounding. The power cord is designed for use with this instrument. Do not use the power cord with other instruments.
- **Connect the Protective Grounding Terminal**
The power cord for the $\mu R10000$ is a three-prong type power cord. Connect the power cord to a properly grounded three-prong outlet.



CAUTION

This instrument is a Class A product. Operation of this instrument in a residential area may cause radio interference, in which case the user is required to take appropriate measures to correct the interference.

Exemption from Responsibility

- YOKOGAWA makes no warranties regarding the product except those stated in the WARRANTY that is provided separately.
- YOKOGAWA assumes no liability to any party for any loss or damage, direct or indirect, caused by the user or any unpredictable defect of the product.

Handling Precautions of the Software

- YOKOGAWA makes no warranties regarding the software accompanying this product except those stated in the WARRANTY that is provided separately.
- Use the software on a single PC.
- You must purchase another copy of the software, if you are to use the software on another PC.
- Copying the software for any purposes other than backup is strictly prohibited.
- Please store the original media containing the software in a safe place.
- Reverse engineering, such as decompiling of the software, is strictly prohibited.
- No portion of the software supplied by YOKOGAWA may be transferred, exchanged, sublet, or leased for use by any third party without prior permission by YOKOGAWA.

Handling Precautions

- Use care when cleaning the recorder, especially any plastic parts. When cleaning, wipe using a dry soft cloth. Do not use chemicals such as benzene or thinner, since these may cause discoloring and deformation.
- Keep electrically charged objects away from the signal terminals. This may damage the recorder.
- Do not apply volatile chemicals to the door glass, display, panel keys, etc. Do not allow rubber and vinyl products to remain in contact with the recorder for long periods of time. This may damage the recorder.
- When not in use, make sure to turn OFF the power switch.
- If there are any symptoms of trouble such as strange odors or smoke coming from the recorder, immediately turn OFF the power switch and the power supply source. Then, contact your nearest YOKOGAWA dealer.

SD Memory Card Handling Precautions

- SD memory cards are delicate and should be handled with caution.
- Yokogawa provides no warranty for damage to, or loss of data recorded on the SD memory card, regardless of the cause of such damage or loss. Please always make backup copies of your data.
- Do not store or use the SD memory card in places with static electricity, near electrically charged objects, or where electrical noise is present. Doing so can result in shock or damage.
- Do not disassemble or modify the SD memory card. Doing so can result in damage.
- Do not physically shock, bend, or pinch the SD memory card. Doing so can lead to malfunction.
- During reading/writing of data, do not turn OFF the power, apply vibration or shock, or pull out the card. Data can become corrupt or permanently lost.
- Only use Yokogawa SD memory cards. Operation cannot be guaranteed with other brands of card.
- When inserting the SD memory card into the instrument, make sure you orient the card correctly (face up or down) and that you insert it securely. If not inserted correctly, the card will not be recognized by the instrument.
- Never touch the SD memory card with wet hands. Doing so can lead to shock or malfunction.
- Never use the SD memory card if it is dusty or dirty. Doing so can lead to shock or malfunction.
- The SD memory card comes formatted.
SD memory cards must be formatted according to the standard established by the SD Association (<https://www.sdcard.org/home>). If you want to format the SD memory card, use the instrument's Format function. If using a PC to perform the formatting, use the SD memory card formatter software available from the above SD Association.
- You can use SD/SDHC cards (up to 32 GB) on the μ R10000.

SD Memory Card Specifications

Electrical specifications	Operating voltage: 2.7 V to 3.6 V (memory operation)
Operating temperature/humidity	-25 to 85°C/20 to 85%RH (no condensation)
Storage temperature/humidity	-40 to 85°C/5 to 85%RH (no condensation)

Unit: mm

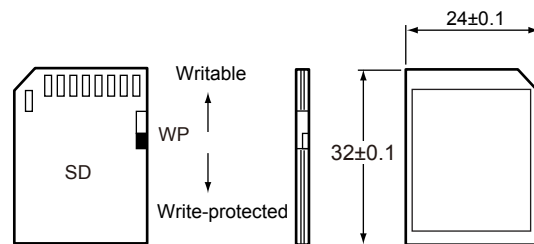

How to Use This Manual

This manual covers information regarding the recorders with English as the display/printing language (suffix code "2"). The following markings are used in this manual.



Improper handling or use can lead to injury to the user or damage to the instrument. This symbol appears on the instrument to indicate that the user must refer to the user's manual for special instructions. The same symbol appears in the corresponding place in the user's manual to identify those instructions. In the manual, the symbol is used in conjunction with the word "WARNING" or "CAUTION."

WARNING

Calls attention to actions or conditions that could cause serious or fatal injury to the user, and precautions that can be taken to prevent such occurrences.

CAUTION

Calls attention to actions or conditions that could cause light injury to the user or damage to the instrument or user's data, and precautions that can be taken to prevent such occurrences.

Note

Calls attention to information that is important for proper operation of the instrument.

Checking the Contents of the Package

Unpack the box and check the contents before operating the instrument. If some of the contents are not correct or missing or if there is physical damage, contact the dealer from which you purchased them.

μR10000 Recorder

A name plate is affixed to the case. Check that the model name and suffix code given on the name plate on the rear panel match those on your order.

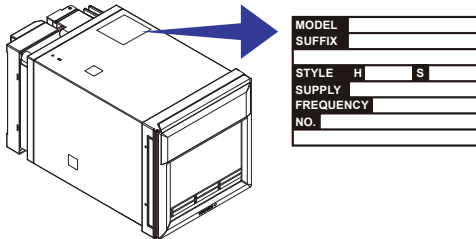

NO. (Instrument Number)

When contacting the dealer from which you purchased the instrument, please give them the instrument number.

MODEL and SUFFIX Code

Model	Suffix Code	Optional Code	Description
436101			μR10000 1 pen recorder
436102			μR10000 2 pen recorder
436103			μR10000 3 pen recorder
436104			μR10000 4 pen recorder
436106			μR10000 6 dot recorder
	-2		English/German/French & deg F/DST
	/A1		Alarm output relay 2 points ¹
	/A2		Alarm output relay 4 points ¹
	/A3		Alarm output relay 6 points ¹
	/C3		RS-422A/485 interface ²
	/C7		Ethernet (10BASE-T) interface ²
	/H2		Clamped input terminal ³
	/H3		Non-glare door glass
	/H5D		Portable type Power cord UL, CSA st'd ⁶
	/H5F		Portable type Power cord VDE st'd ⁶
	/H5R		Portable type Power cord AS st'd ⁶
	/H5J		Portable type Power cord BS st'd ⁶
	/H5H		Portable type Power cord GB st'd ⁶
	/M1		Mathematical function
	/N1		Cu10, Cu25 RTD input
	/N2		3 legs isolated RTD ^{3,4}
	/N3		Expansion inputs ⁵
	/P1		24 VDC/AC power supply ⁶
	/R1		Remote control 5 points
	/CC1		Calibration Correction
	/BT1		Header printout
	/EM1		SD memory card ⁷
	/S#		Customized Product; for more detail, please see IM 4361-S# or IM 4371-S# ⁸

- 1 /A1, /A2, and /A3 cannot be specified simultaneously.
- 2 /C3 and /C7 cannot be specified simultaneously.
- 3 /H2 and /N2 cannot be specified simultaneously.
- 4 Valid only on the model 436106.
- 5 14 types of input including Pt50 RTD, PR40-20, and Platinel TC.
- 6 /H5x and /P1 cannot be specified simultaneously.
- 7 /C3 and /EM1 cannot be specified simultaneously.
- 8 For customized product, the product is identified by the option code of /S# (where '#' is a number). Contact your supplier in case your instrument has option /S#, and you are not in the possession of IM 4361-S# or IM 4371-S#.

Standard Accessories

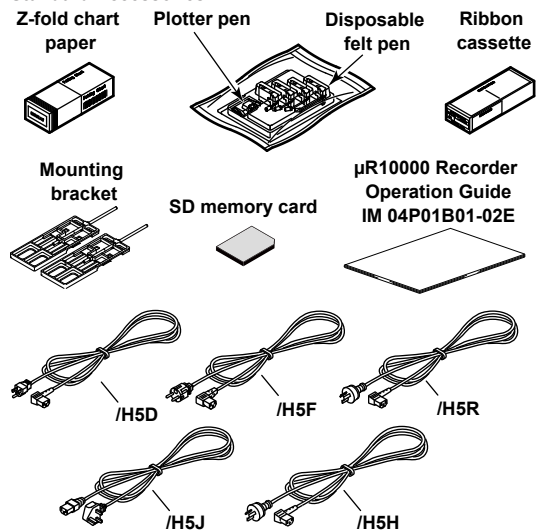

One of these power cord types is supplied according to the instrument's suffix code

Part Number	Note
A1006WD	Provided when optional code /H5D is specified. Maximum rated power voltage: 125 V
A1009WD	Provided when optional code /H5F is specified. Maximum rated power voltage: 250 V
A1024WD	Provided when optional code /H5R is specified. Maximum rated power voltage: 250 V
A1023WD	Provided when optional code /H5J is specified. Maximum rated power voltage: 250 V
A1064WD	Provided when optional code /H5H is specified. Maximum rated power voltage: 250 V

Item	1-Pen	2-Pen	3-Pen	4-Pen	Dot
Z-fold chart paper	1	1	1	1	1
Ribbon cassette	-	-	-	-	1
Disposable felt pen	Red	1	1	1	-
	Green	-	1	1	-
	Blue	-	-	1	-
	Violet	-	-	-	1
Plotter pen	Purple	1	1	1	-
Mounting bracket (included with models without /H5x)	2	2	2	2	2
Power cord (included with /H5x)	1	1	1	1	1
SD memory card 1 GB (included with /EM1)	1	1	1	1	1
µR10000 Recorder Operation Guide IM 04P01B01-02E	1	1	1	1	1

Software (Sold Separately, see page 8)

Item	Model	Note
Configuration software	RXA10-01	
	RXA10-02	With interface unit*

* You can use the Configuration Software if you install the interface unit to a recorder does not include the communication function. An interface unit cannot be installed in a recorder with an SD memory card function (/EM1 option).

The optional accessories below are available for purchase separately. If you make an order, make sure that all contents are present and undamaged.

For information about ordering accessories, contact the dealer from which you purchased the recorder.

Item	Model	Quantity	Note
Z-fold chart paper	B9565AW	1	10 pieces.
Ribbon cassette	B9901AX	1	
Disposable felt pen	Red	B9902AM	1 3 pieces.
	Green	B9902AN	1 3 pieces.
	Blue	B9902AP	1 3 pieces.
	Violet	B9902AQ	1 3 pieces.
Plotter pen	Purple	B9902AR	1 3 pieces.
Mounting bracket	B9900BX	2	
Shunt resistor for the screw terminal (standard)	415920	1	250 Ω ±0.1%
	415921	1	100 Ω ±0.1%
	415922	1	10 Ω ±0.1%
Shunt resistor for the clamped input terminal (/H2)	438920	1	250 Ω ±0.1%
	438921	1	100 Ω ±0.1%
	438922	1	10 Ω ±0.1%
SD memory card	773001	1	1 GB

Recorder Style Number, Release Number, and Firmware Version Number

Style number: The recorder hardware ID number.

This number is written on the name plate.

Release number: The recorder firmware ID number. This number is written on the name plate. This number matches with the integer part of the firmware version number.

Example: If the firmware version number is 2.01, the release number is 2.

Firmware version number: See "Checking the Version Number."

MODEL SUFFIX		
STYLE	H	S
SUPPLY FREQUENCY NO.		

Style number

Release number

Removing the Packing Materials

Open the door, put your finger on the tab at the lower left of the display and key panel section, and open the display and key panel section.

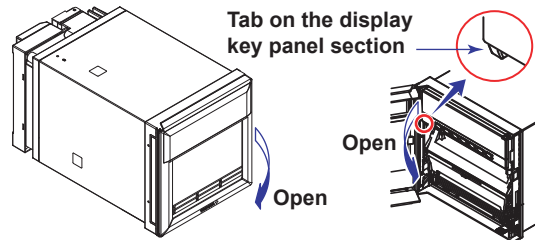

Remove all packing materials.

• Pen Model

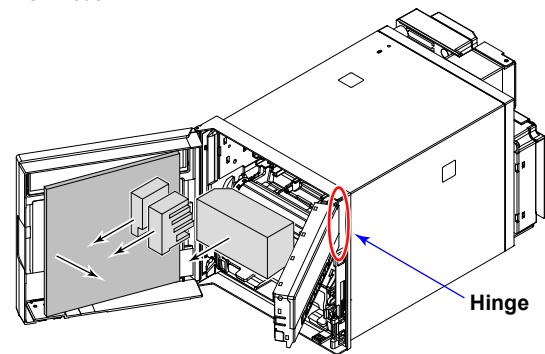

• Dot Model

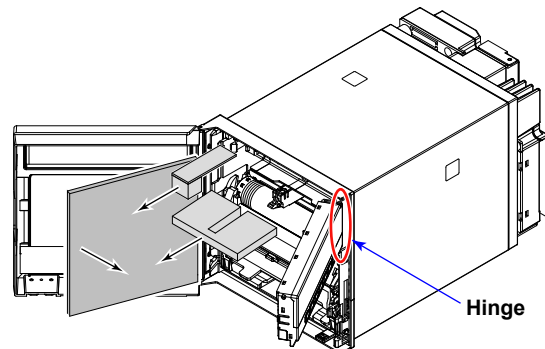

CAUTION

To protect the hinges, do not apply vertical force on the display and key panel section.

Recorder's Version and Functions Described in This Manual

The contents of this manual corresponds to the recorder with version 1.5x.

μR10000 Versions and Functions

Version	Suffix Code	Added or Modified Functions	Reference
1.02 or earlier	–	–	–
1.1x	–	(Added) The printout/display format of the date can be changed.	Sec. 7.19 in the User's Manual (IM 04P01B01-01E)
	–	(Added) Key operation to move the printer carriage near the center position so that the ribbon cassette can be replaced with the recorder turned ON (dot model)	Sec. 3.4 in the User's Manual (IM 04P01B01-01E)
	–	(Changed) Selectable range of alarm values during linear scaling (including 1-5V and SQRT) to -5% to 105% of the scale span.	Sec. 5.2 in the User's Manual (IM 04P01B01-01E)
	–	(Changed) The procedure to set the start/end date and time of Daylight Saving Time (DST) has been changed.	Sec. 6.16 in the User's Manual (IM 04P01B01-01E)
	/C3	(Added) Modbus/RTU slave protocol, two-wire system	Communication manual
	/C7	(Changed) Users with the same user name cannot be registered.	Communication manual
1.2x	-2	(Added) Language support (German and French)	Sec. 1.9 in the User's Manual (IM 04P01B01-01E)
	/CC1	(Added) Calibration Correction	Sec. 1.2 in the User's Manual (IM 04P01B01-01E)
	/H5x	(Added) Portable type	Pages 15 and 20 in this manual
	/P1	(Added) 24 VDC/AC power supply operation	Pages 20 and 21 in this manual
1.3x	–	(Added) Customized menu	Sec. 1.9 in the User's Manual (IM 04P01B01-01E)
	–	(Added) Modbus register (40301 to 40348)	Communication manual
	/BT1	(Added) Header printout	Sec. 1.4 in the User's Manual (IM 04P01B01-01E)
1.4x	/EM1	(Added) SD memory card	IM 04P01B01-03E
1.5x	–	(Changed) Styl (H): 4* * Style (H) 4 supports firmware version 1.5x or later.	–

- Checking the Version Number

You can check the version number on the System display.

The System display cannot be shown at the factory default condition.

First, register the System display to the display screen.

- Procedure of registering the System display to the display screen: See Changing the Displayed Information on Page 47.

- Procedure of displaying the System display: The screen switches each time the **[DISP]** key is pressed. Press the **[DISP]** key repeatedly until System display is shown. The displayed contents on the System display switches every 3 seconds. Check the number shown by the "Version:" item.

Software (Sold Separately)

The table below shows the relationship between the RXA10 Configuration Software revisions and the μR10000 recorder versions.

		Recorder version					
		1.02 or earlier	1.1x	1.2x	1.3x	1.4x	1.5x
RXA10 Configuration Software revision	R1.01	Yes	Limited				
	R2.01	Yes	Yes	Yes	Limited		
	R3.01	Yes	Yes	Yes	Yes	Limited	
	R3.05	Yes	Yes	Yes	Yes	Yes	Limited
	R3.06	Yes	Yes	Yes	Yes	Yes	Yes

Yes: Compatible

Limited: The new functions of the recorder cannot be configured from the RXA10.

Protection of Environment

Control of Pollution Caused by the Product

This is an explanation for the product based on "Control of pollution caused by Electronic Information Products" in the People's Republic of China.

产品中含有的有毒有害物质或元素的名称和含量

部件名称	有毒有害物质或元素					
	铅 (Pb)	汞 (Hg)	镉 (Cd)	六价铬 (Cr6+)	多溴联苯 (PBB)	多溴二苯醚 (PBDB)
印制电路板组件	×	×	×	○	○	○
显示器	×	×	×	○	○	○
箱体	×	×	×	○	○	○
前盖	×	×	×	○	○	○
内部单元底座	○	○	○	○	○	○
电源	×	×	×	○	○	○
操作键	×	×	×	○	○	○
打印单元	×	×	×	○	○	○
制动器 (电机、螺线管)	×	×	×	○	○	○
输入端子和可选端子	×	×	×	○	○	○
电缆	×	○	○	○	○	○
附件 / 可选项	6 色盒式色带	○	○	○	○	○
	可拆卸式毡笔	○	○	○	○	○
	绘图笔	○	○	○	○	○
	安装支架	×	×	×	○	○
	电源线	×	×	×	○	○
	分流电阻	×	×	×	○	○
	SD 存储卡	×	×	×	○	○

○：表示该部件所有基材中所含的有毒有害物质含量均未超过 GB/T26572 标准中规定的限量要求。
 ×：表示该部件中至少有一种基材中所含的有毒有害物质含量超过 GB/T26572 标准所规定的限量要求。

本产品的部分部件包含 RoHS 指令中的限用物质，但是其使用方法不受该指令限制。
 Some parts of this product include the restricted substances of RoHS Directive, but their applications are under the exemption of the directive.

环境保护使用期限



该标志为环境保护使用期限，根据 SJ/T11364，适用于在中国（台湾、香港、澳门除外）销售的电子电气产品。

只要遵守该产品的安全及使用注意事项，从产品生产之日起至该标志所示年限内，不会因为产品中的有害物质外泄或突变而导致环境污染或对人身财产产生重大影响。

注释）该标志所示年限为“环境保护使用期限”，并非产品的保质期。另外，关于更换部件的推荐更换周期，请参阅使用说明书。

Waste Electrical and Electronic Equipment (WEEE)



This is an explanation of how to dispose of this product based on Waste Electrical and Electronic Equipment (WEEE), Directive and Regulation.

Only valid in the EEA for EU WEEE Directive and in the UK for UK WEEE Regulation.

- Marking

This product complies with the WEEE marking requirement. This marking indicates that you must not discard this electrical/electronic product in domestic household waste. When disposing of products in the EEA or UK, contact your local Yokogawa office in the EEA or UK respectively.

How to Dispose the Batteries



This is an explanation about the EU Battery Directive/Regulation and UK Battery Regulation.

Only valid in the EEA for EU Battery Directive/Regulation and in the UK for UK Battery Regulation.

Batteries are included in this product. Batteries incorporated into this product cannot be removed by yourself. Dispose them together with this product.

When you dispose this product in the EEA or UK, contact your local Yokogawa office in the EEA or UK respectively. Do not dispose them as domestic household waste.

Battery type: Lithium battery

Notice: The symbol (see above) means they shall be sorted out and collected as ordained in the EU Battery Directive/Regulation and UK Battery Regulation.

Function Introduction/Names of Parts

Function Introduction

The μ R10000 Recorder (hereafter referred to as the recorder) can be used to assign DC voltage, 1-5V, thermocouple, RTD, and contact or voltage ON/OFF signal to channels for measurement. The measured results are recorded with pens or dots on a chart paper that is fed at a constant speed. The pen model can record up to 4 channels; the dot model can record up to 6 channels.

μ R10000 Recorder

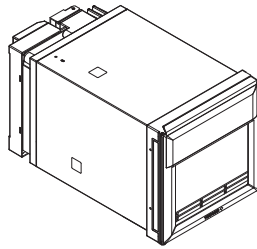

Recording example (dot model)

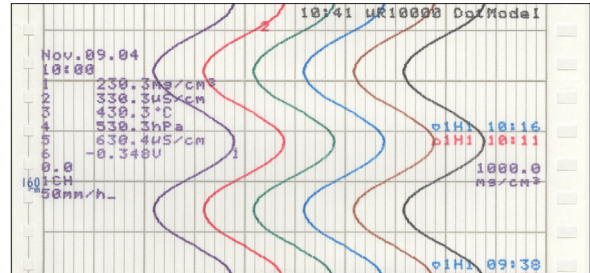

Alarms

For each channel, various alarms such as high limit alarm and low limit alarm can be assigned to monitor the measured values. Alarm output relays can be used to output contact signals when alarms occur (/A1, /A2, and /A3 options).

Recording

The measured results are recorded with pens or dots on a chart paper (trend recording). The chart speed can be selected from 5 to 12000 mm/h on the pen model and 1 to 1500 mm/h on the dot model.

In addition to trend recording, various types of information can be printed on the chart paper such as numeric measured values, alarm occurrence/release, and predefined messages.

Also, the recorder settings can be printed.

Internal Light

A light is provided for easier viewing of the recording area of the chart paper.

Display

Measured values can be displayed numerically or using bar graphs on the large display. Also, alarm status and chart speed can be displayed.

Communication Functions

Using the Ethernet communication interface (/C7 option) or the RS-422A/485 communication interface (/C3 option), the measured values on the recorder can be output to a computer or a computer can be used to control the recorder.

For information about the communication functions, see the *μ R10000/ μ R20000 Communication Interface User's Manual*, IM 04P01B01-17E.

Other Main Functions

The computation function (/M1 option) can be used to perform various computations from four arithmetic operations to statistical calculations on 8 and 12 computation channels on the pen model and dot model, respectively. The computed results can be recorded.

The remote control function (/R1 option) can be used to control the recording start/stop and other operations of the recorder by applying contact signals to the dedicated terminals.

The FAIL/chart end detection and output function (/F1 option) can be used to output contact signals when errors are detected on the recorder or when the chart paper runs out.

Names of Parts Front

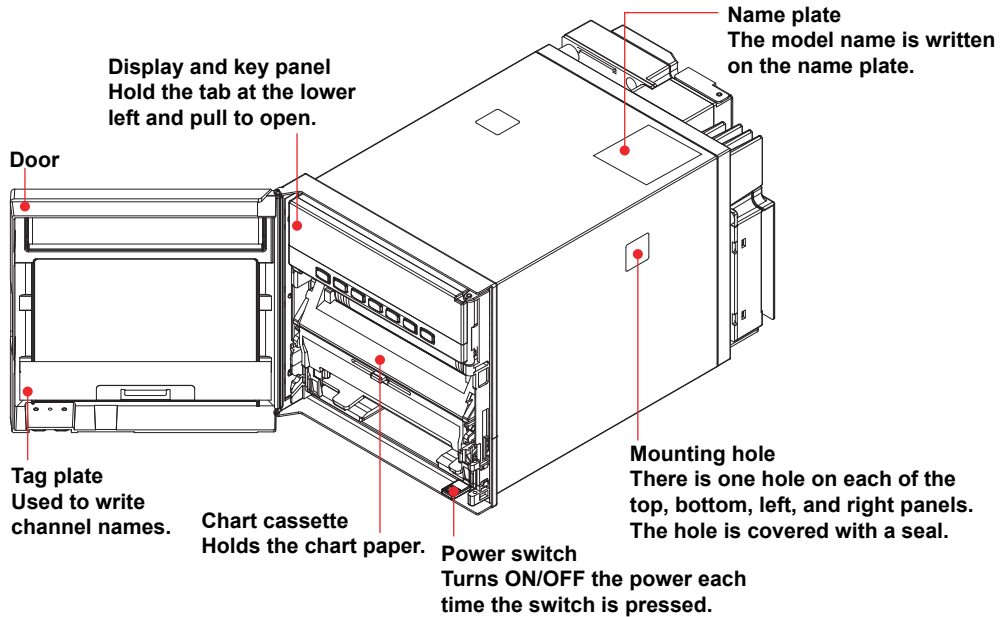

Pen model

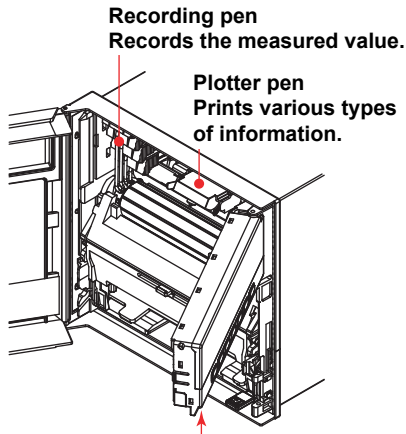

Dot model

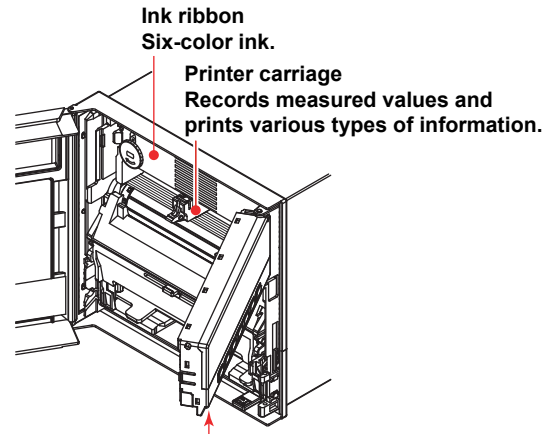

Display and key panel (see the next page)
There is an internal light on the bottom section of the display and key panel. It lights up the recording area of the chart paper.

Rear Panel

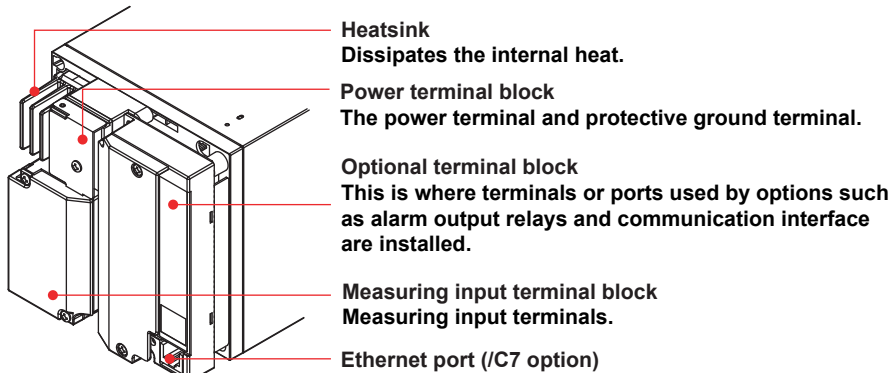

The portable type (/H5x option) comes with a handle, feet, and dedicated power supply connector.

Display and Key Panel

Status display

Displays the following information.

RECORD Illuminates while recording measured values.

KEY LOCK Illuminates when key lock is enabled.

MATH Illuminates when computation on the computation function (/M1 option) is in progress.

CHART END Illuminates when the chart paper is out (/F1 option).

ALARM 1 to 6 Illuminates when an alarm is occurring on channels 1 to 6.

Main display

Displays the measured values. Also, displays the setup screen when setting functions.

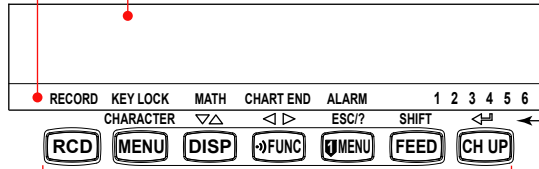

Seven keys are available.

For all keys except RCD, functions marked above the keys are enabled when setting functions or when the FUNC key or the DISP MENU key is pressed.

<While setting functions, when the FUNC key/DISP MENU key is pressed>

CHARACTER Key: Changes the character type when entering a character. Press this key while holding down the SHIFT key to switch the character type in reverse order.

UP/DOWN Key: Switches the setup item or the value.

Press this key while holding down the SHIFT key to switch the setup item or the value in reverse order.

LEFT/RIGHT Key: Moves the cursor to the right when entering a value or character. Press this key while holding down the SHIFT key to move the cursor to the left.

ESC Key: Cancels the operation.

When pressed with the SHIFT key, the display of the comment on the setting turns ON/OFF.

SHIFT Key: Used with the ∇/Δ key, \leftarrow/\rightarrow key, the CHARACTER key, or the ESC key.

ENTER Key: Confirms the setup item or value.



<During normal operation>

CH UP key
Switches the displayed channel.
(when manual switching is specified)

FEED key
Feeds the chart paper.

DISP MENU key
Hold this key down for 3 seconds to switch to the data display setup screen. Hold this key down for 3 seconds also to exit from the data display setup screen.

FUNC key
Used when executing manual printout, message printout, etc.

DISP key
Switches the screen in the main display.

MENU key
Hold this key down for 3 seconds to enter Setting mode. Hold this key down for 3 seconds also to exit from Setting mode.

RCD key
Starts/stops recording.

Installing/Wiring the Recorder

Installation Location

Install the recorder indoors in a location that meets the following conditions.

- **Instrument Panel**
The recorder is designed for panel mounting. The portable type (/H5x option) is designed to be used on the desktop.
- **Well-Ventilated Location**
To prevent overheating, install the recorder in a well-ventilated location. For the panel cut dimensions when arranging multiple recorders, see page 15. Follow the panel cut dimensions providing adequate space between instruments when other instruments are arranged on the panel. We recommend that you secure at least 50 mm of space from the left, right, top, and rear panels on the portable type (/H5x option).
- **Minimum Mechanical Vibrations**
Choose an installation location with the minimum mechanical vibration. Installing the recorder in a location with large mechanical vibration not only causes adverse effects on the mechanism but also may hinder normal recording.
- **Horizontal**
Install the recorder horizontally (However, the recorder can be inclined up to 30 degrees backwards for panel mounting).
- **Ambient temperature range between 0 to 50°C**
- **Ambient humidity between 20 to 80%RH (at 5 to 40°C) or 30 to 50%RH (at 0 to 5, 40 to 50°C), No condensation should be present.**
- **Altitude 2000 m or less**

Note

- Condensation may occur if the recorder is moved to another place where both the ambient temperature and humidity are higher, or if the temperature changes rapidly. In addition, measurement errors will result when using thermocouples. In this case, let the recorder adjust to the new environment for at least one hour before using it.
- The chart paper may be adversely affected by a rapid change in the ambient temperature and humidity.

Do not install the recorder in the following places.

- **Outdoors**
- **In Direct Sunlight or Near Heat Sources**
Install the recorder in a place with small temperature fluctuations near room temperature (23°C). Placing the recorder in direct sunlight or near heat appliances can cause adverse effects on the internal circuitry.
- **Where an Excessive Amount of Soot, Steam, Moisture, Dust, or Corrosive Gases Are Present**
Soot, steam, moisture, dust, and corrosive gases will adversely affect the recorder. Avoid such locations.
- **Near Strong Magnetic Field Sources**
Do not bring magnets or instruments that produce electromagnetic fields close to the recorder. Strong magnetic fields can cause errors in the measurements.

Installation Procedure

The recorder should be mounted on a steel panel of thickness 2 mm to 26 mm.

1. Insert the recorder from the front of the panel (see the diagram on the next page).
2. Mount the recorder to the panel using the mounting brackets provided.
 - Use two brackets to support the top and bottom or the left and right sides of the case (remove the seal that is covering the holes for the mounting brackets beforehand).

- The proper torque for tightening the mounting screws is 0.7 to 0.9 N•m.
- Mount the recorder to the panel according to the procedure below.
 - First, attach the two mounting brackets and temporarily fasten the attachment screws.
 - Next, fix the recorder in place by tightening the attachment screws with the appropriate torque. When the recorder is approximately perpendicular to the panel as you fasten the screws, press the mounting bracket against the case so that they are in contact with each other.

CAUTION

Tightening the screws too much can deform the case or damage the bracket.

Panel Mounting Diagram

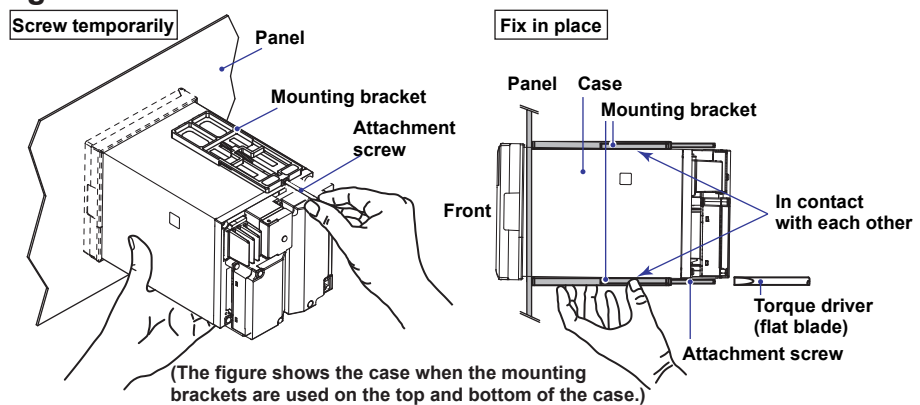

External Dimensions

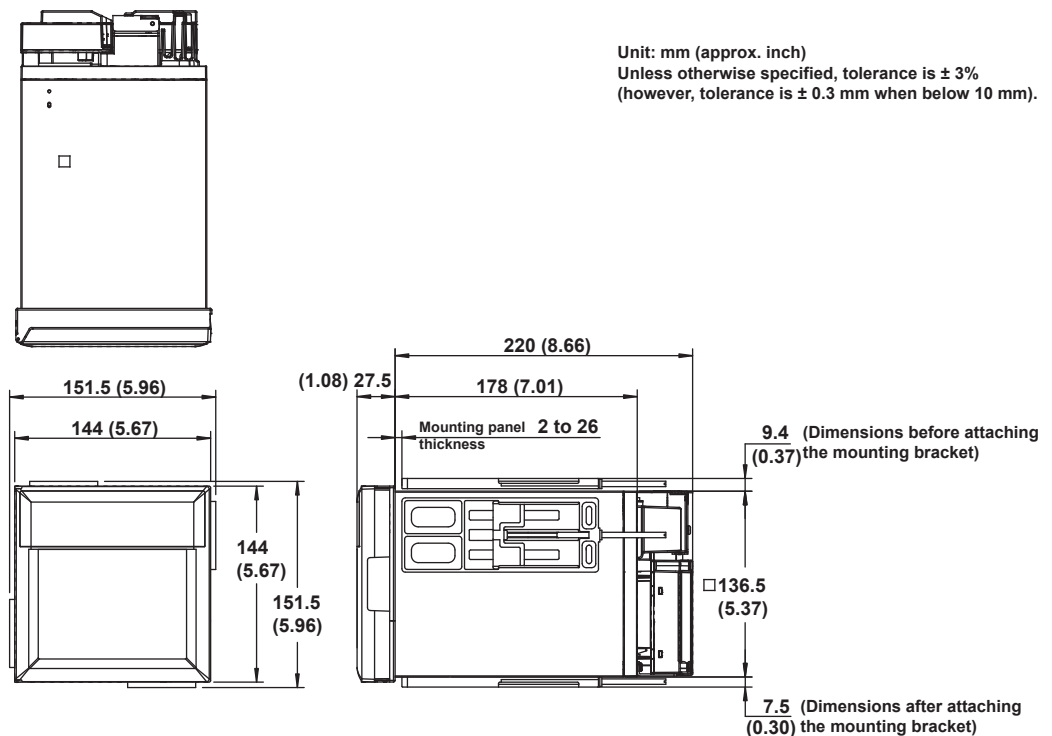

Panel Cutout

Single-Unit Mounting

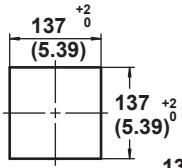

Side-by-Side Mounting (horizontally)

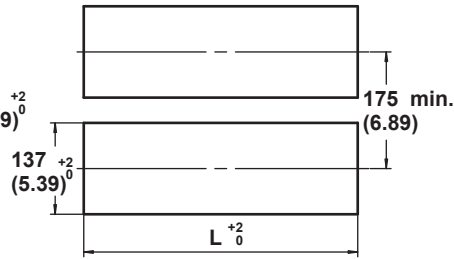

Side-by-Side Mounting (vertically, max. 3 units)

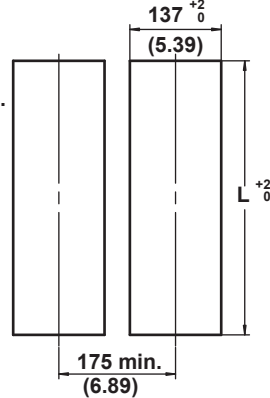

Units	L (mm)
2	282
3	426
4	570
5	714
6	858
7	1002
8	1146
9	1290
10	1434
n	(144xn)-6

Attach the mounting brackets to the top and bottom when mounting the recorders side-by-side horizontally or right and left when mounting the recorders side-by-side vertically.

Unit: mm (approx. inch)

Unless otherwise specified, tolerance is $\pm 3\%$ (however, tolerance is ± 0.3 mm when below 10 mm).

External Dimensions of the Portable Type (/H5x Option)

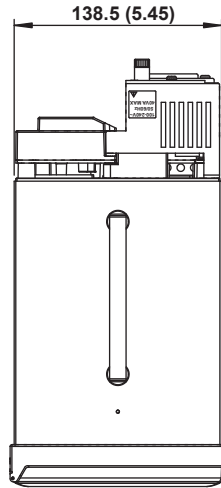

Unit: mm (approx. inch)
Unless otherwise specified, tolerance is $\pm 3\%$ (however, tolerance is ± 0.3 mm when below 10 mm).

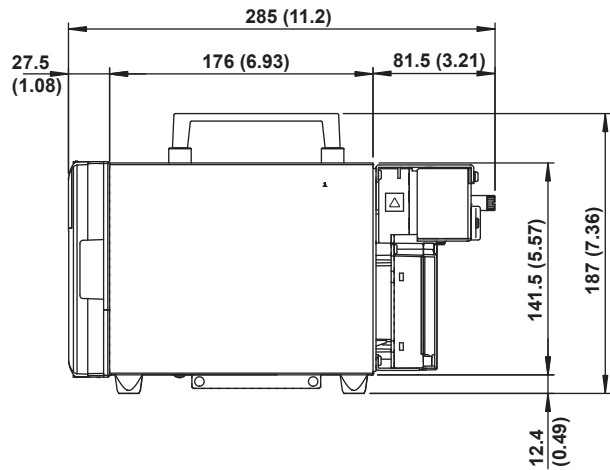
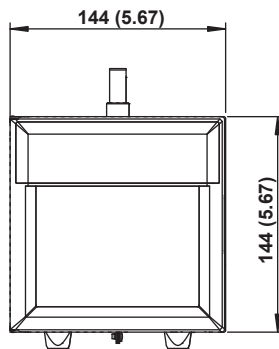
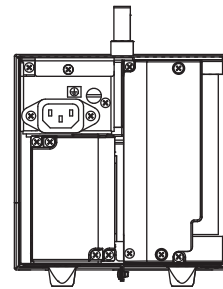

Input Signal Wiring



WARNING

- To prevent electric shock while wiring, ensure that the power supply source is turned OFF.

CAUTION

- The input terminals of this instrument are specific to this instrument. Do not connect the input terminals of the μ R1000, μ R1800 or other models, as malfunction may result.
- If a strong tension is applied to the cable wired to the recorder, the terminals of the recorder and/or the cable can be damaged. In order to prevent tension from being applied directly on the terminals, fasten all wiring cables to the rear of the mounting panel.
- Do not apply a voltage exceeding the following value to the input terminals as this may damage the recorder.
 - Maximum input voltage
Voltage range less than or equal to 200 mVDC, TC, RTD, and DI: ± 10 VDC
Ranges other than those listed above: ± 60 VDC
 - Maximum common-mode voltage
 ± 60 VDC (under measurement category II conditions)

Precautions to Be Taken While Wiring

Take the following precautions when wiring the input signal cables.

It is recommended that crimp-on lug with insulation sleeves (designed for 4-mm screws) be used when connecting the input/output signal wires to the terminals. However, this does not apply clamped terminals (/H2).



— Crimp-on lug with insulation sleeves (for 4-mm screws)

For clamped terminals (/H2), the following wire is recommended.

- Conductive cross-sectional area for single wire: 0.14 mm^2 to 1.5 mm^2 , stranded wire: 0.14 mm^2 to 1.0 mm^2
- Length of the stripped section of the wire: Approx. 5 mm

Take measures to prevent noise from entering the measurement circuit.

- Move the measurement circuit away from the power cable (power circuit) and ground circuit.
- It is desirable that the object being measured does not generate noise. However, if this is unavoidable, isolate the measurement circuit from the object. Also, ground the object being measured.
- Shielded wires should be used to minimize noise caused by electrostatic induction. Connect the shield to the ground terminal of the recorder as necessary (make sure you are not grounding at two points).
- To minimize noise caused by electromagnetic induction, twist the measurement circuit wires at short, equal intervals.
- Make sure to earth ground the protective ground terminal through minimum resistance.

Do not allow static electricity to be applied to the terminals.

- When wiring the terminals, remove static electricity so that static electricity is not applied.
- If static electricity or similar high-voltage transient noise is applied to the signal line, the system may break.

When using internal reference junction compensation on the thermocouple input, take measures to stabilize the temperature at the input terminal.

- Always use the terminal cover.
- Do not use thick wires which may cause large heat dissipation (cross sectional area of 0.5 mm^2 or less recommended).
- Make sure that the ambient temperature remains reasonably stable. Large temperature fluctuations can occur if a nearby fan turns ON or OFF.

Connecting the input wires in parallel with other devices can cause signal degradation, affecting all connected devices.

If you need to make a parallel connection, then

- Turn the burnout detection function OFF.
- Ground the instruments to the same point.
- Do not turn ON or OFF another instrument during operation. This can have adverse effects on the other instruments.
- RTDs cannot be wired in parallel.

Wiring Procedure

A terminal cover is screwed in place on the measuring input terminal block on the rear panel. A label indicating the terminal arrangement is affixed to the cover.

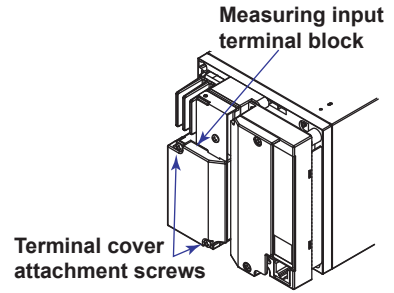

1. Turn OFF the recorder and remove the terminal cover.
2. Connect the signal wires to the terminals.

Note

Input signal wires of diameter less than or equal to 0.3 mm may not be secured firmly for clamped terminals (/H2). Fold over the conducting section of the wire, for example, to make sure that the wire is securely connected to the clamped terminal.

3. Replace the terminal cover and fasten it with screws.
The proper torque for tightening the screws is 0.6 N•m.

Pen Model

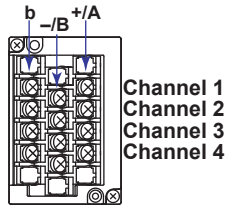

Screw input terminal

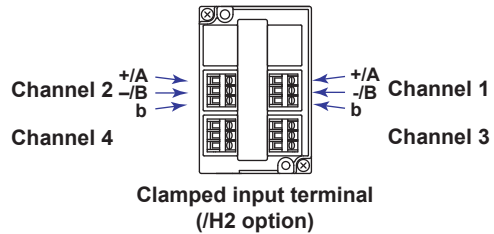

Dot Model

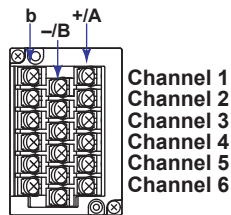

Screw input terminal

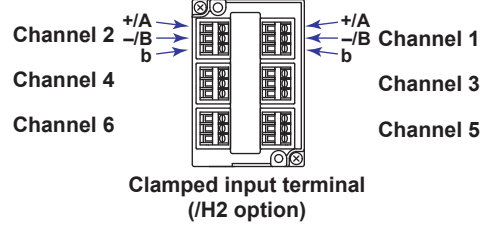

Measuring Input Wiring

Thermocouple input

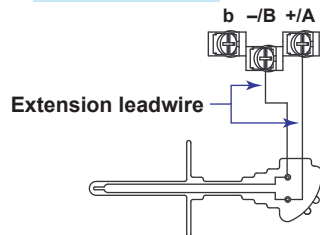

Resistance temperature detector input

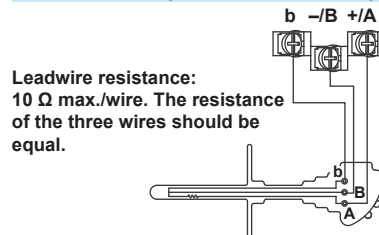

DC voltage input, 1-5V input, and ON/OFF input

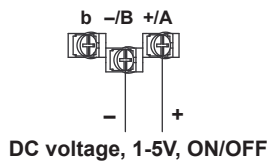

DC current input

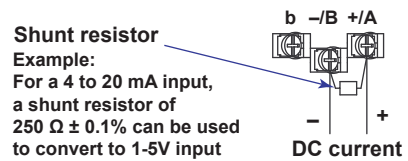

Note

RTD input terminals A and B on the dot model are isolated on each channel. Terminal b is shorted internally across all channels. However, for 3 legs isolated RTDs (/N2 option), input b is also isolated for each channel.

Optional Terminal Wiring



WARNING

- To prevent electric shock while wiring, ensure that the power supply source is turned OFF.
- If a voltage of more than 30 VAC or 60 VDC is to be applied to the output terminals, use ring-tongue crimp-on lugs with insulation sleeves on all terminals to prevent the wires from slipping out when the screws become loose. Furthermore, use double-insulated wires (dielectric strength of 3000 VAC or more) for the signal wires on which a voltage of more than 30 VAC or 60 VDC is to be applied. For all other wires, use basic insulated wires (dielectric strength of 1500 VAC). To prevent electric shock, attach the terminal cover after wiring and make sure not to touch the terminals.

CAUTION

- The option terminals of this instrument are specific to this instrument. Do not connect the option terminals of the μ R1000, μ R1800 or other models, as malfunction may result.
- To prevent fire, use signal wires for recorder having a temperature rating of 70°C or more.
- If a strong tension is applied to the cable wired to the recorder, the terminals of the recorder and/or the cable can be damaged. In order to prevent tension from being applied directly on the terminals, fasten all wiring cables to the rear of the mounting panel.
- Use the following circuit voltage for the connection to the alarm/FAIL/status output terminal.
 - When the connection is to Mains Circuits (primary AC power source circuits): 150 V or less
 - When the connection is to circuits derived from Mains Circuits (secondary circuits): 250 V or less (Mains Circuits voltage is less than 300 V, and connection must be used by isolation transformer.)

Wiring Procedure

As shown in the figure below, the optional terminal block is located on the rear panel. The optional terminal block is provided on the recorder when an option that requires input/output is installed such as the alarm output relay (/A1, /A2, or /A3 option), FAIL/chart end output (/F1 option), remote control function (/R1 option), RS-422A/485 interface (/C3 option)*, and Ethernet (10BASE-T) interface (/C7 option)*. A terminal cover is screwed in place on the measuring input terminal block. A label indicating the terminal arrangement is affixed to the terminal block.

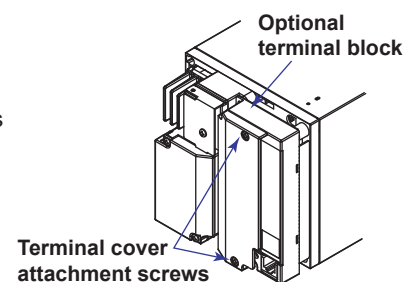

* For details on terminal and connector arrangement and wiring, see the μ R10000 / μ R20000 Communication Interface User's Manual (IM 04P01B01-17E).

1. Turn OFF the recorder and remove the terminal cover.
2. Connect the input signal wires to the terminals.
3. Replace the terminal cover and fasten it with screws.
The proper torque for tightening the screws is 0.6 N•m.

Note

To reduce noise, use a shielded cable for the wiring of the remote control input terminals. Connect the shield to the ground terminal of the recorder.

Installing/Wiring the Recorder

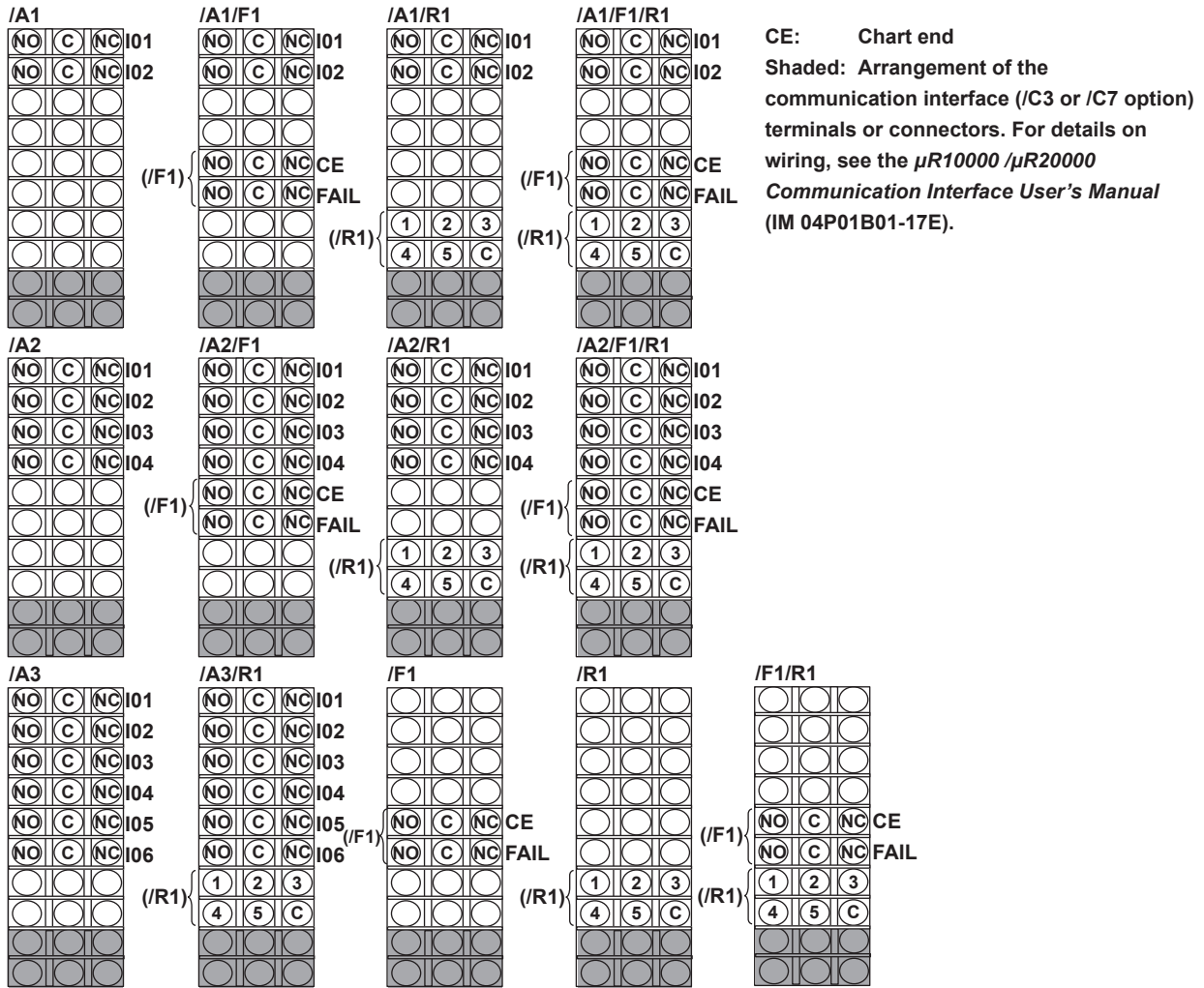

Alarm Output Relay Terminals and FAIL/Chart End Output Relay Terminals

Alarm output terminals 01 to 06 are expressed as I01 to I06 in the alarm output relay settings.

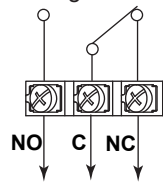

- Output:** Relay contact
- Contact rating:** 250 VAC (50/60 Hz) /3 A, 250 VDC/0.1 A (for resistor load)
- Dielectric strength:** 1500 VAC at 50/60 Hz for one minute (between output terminals and the ground terminal)

NO(Normally Opened), **C**(Common), **NC**(Normally Closed)

Remote Control Input Terminals

Remote control input terminals 1 to 5 are expressed as numbers 1 to 5 in the remote control input settings.

- Relay contact input (Voltage-free contact)**

Contact closed at 200 Ω or less
 Contact open at 100 kΩ or greater

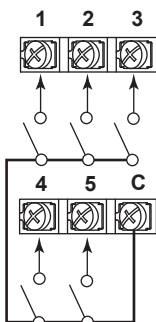

- Transistor input (Open collector)**

ON voltage: 0.5 V or less (30 mADC)
 Leakage current when turned OFF: 0.25 mA or less

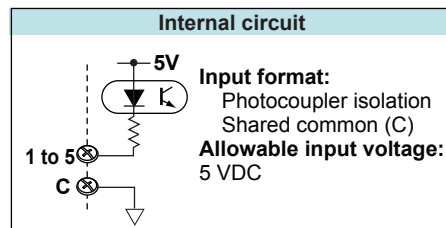
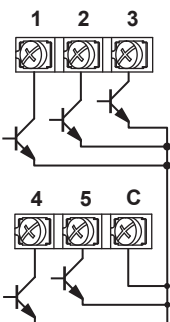

C: Negative side of the power supply

1 to 5 (Remote control input terminals), C (Common)

Dielectric strength: 500 VDC for one minute (between input terminals and the ground terminal)

Power Supply Wiring



WARNING

Panel Mount Type

- To prevent electric shock when wiring, ensure the main power supply is turned OFF.
- To prevent the possibility of fire, use 600 V PVC insulated wire (AWG20 to 16) or an equivalent wire for power wiring.
- Make sure to earth ground the protective earth terminal through a minimum grounding resistance before turning ON the power.
- Use crimp-on lugs (designed for 4-mm screws) for power and ground wiring termination.
- To prevent electric shock, make sure to close the transparent cover for the power supply wires.
- For safety, provide a double-pole switch in an easily operable location near the recorder to disconnect the recorder from the main power supply. Put an indication on this switch as the breaker on the power supply line for the recorder and indications of ON and OFF.

Switch specifications

Rated power current: 1 A or more (other than /P1), 3 A or more (/P1 option)

Rated rush current: 60 A or more (other than /P1), 70 A or more (/P1 option)

Complies with IEC 60947-1, 3.

- Connect a fuse in the power supply line.
2 A to 15 A (other than /P1), 4 A to 15 A (/P1 option)
- Do not add a switch or fuse to the ground line.

Portable Type (/H5x Option)

- Ensure that the source voltage matches the rated power supply voltage of the instrument before connecting the power cord.
- Connect the power cord after checking that the power switch of the portable type is turned OFF.
- To prevent electric shock or fire, be sure to use the power cord for the portable type supplied by YOKOGAWA.
- Make sure to connect protective earth grounding to prevent electric shock. Connect the power cord of the portable type to a three-prong power outlet equipped with a protective earth terminal.
- Do not use an extension cord that does not have a protective grounding wire. The protective features of the instrument will be rendered ineffective.

Use a power supply that meets the following conditions:

Item	Power Supply Specifications	
	(Options Other Than /P1)	(/P1 Option)
Rated supply voltage	100 to 240 VAC	24V DC/AC
Allowable power supply voltage range	90 to 264 VAC	21.6 V to 26.4 VDC/AC
Rated power supply frequency	50/60 Hz	50/60 Hz (for AC)
Allowable power supply frequency range	50/60 Hz $\pm 2\%$	50/60 Hz $\pm 2\%$ (for AC)
Maximum power consumption	40 VA	25 VA (for DC) or 35 VA (for AC)

Note

Do not use a supply voltage in the range 132 to 180 VAC, as this may have adverse effects on the measurement accuracy.

Wiring Procedure (Panel Mount Type)

The power supply terminals and protective ground terminals are located on the rear panel.

1. Turn OFF the power switch on the recorder and open the power terminal cover.
2. Wire the power cord and the protective ground cord to the power supply terminals. Use ring-tongue crimp-on lugs (designed for 4-mm screws).
3. Close the power supply terminal cover and secure it with the screw. The proper torque for tightening the screws is 0.6 N•m.

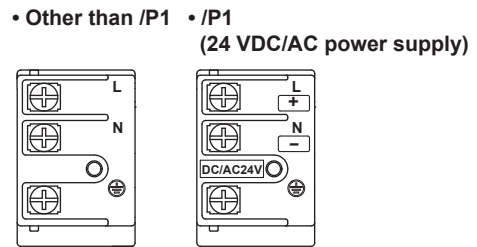
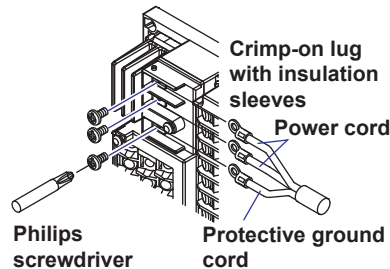
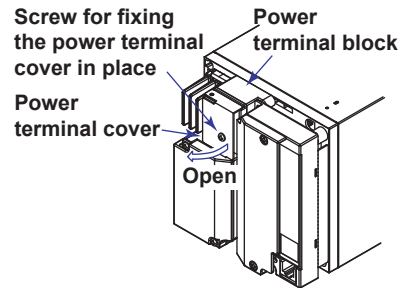

Wiring Procedure (Portable Type (/H5x Option))

1. Check that the power switch to the instrument is turned OFF.
2. Connect the plug on the accessory power cord to the power supply connector on the rear panel.

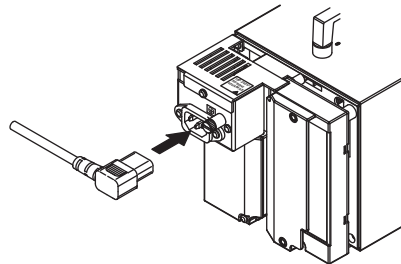

3. Ensure that the power outlet to be used meets the conditions on the previous page and that the voltage of the power supply is within the maximum voltage rating of the power cord, then connect the other end of the power cord to the power supply outlet. The AC outlet must be of a three-prong type with a protective earth ground terminal.

Turning ON/OFF the Power Switch

The power switch is located inside the door at the lower right. The power switch is a push button.

Press once to turn it ON and press again to turn it OFF. When the power switch is turned ON, a self-diagnosis program runs for a few seconds, and the recorder is ready for operation.

Common Operations and Menu Structure

Execution Modes

The recorder has three execution modes.

Operation Mode

This mode is used for normal recording operation. The recorder enters this mode when the power is turned ON.

Setting Mode

This mode is used to set the input range, alarms, chart speed, and other parameters. These settings can be changed while recording is in progress. However, the input range of measurement channels and the computing equation, unit, constant, and TLOG setting of computation channels cannot be changed while computation (/M1 option) is in progress.

Basic Setting mode

This mode is used to set the basic specifications of the recorder such as the thermocouple burnout detection function and the alarm output relay operation. This mode cannot be entered while the recorder is recording or while computation is in progress on the computation function (/M1 option). Measurement, recording, and alarm detection cannot be carried out in this mode.

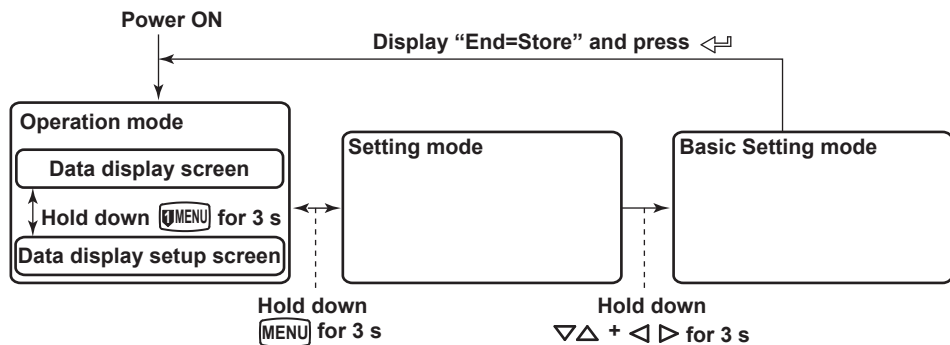

Operation Sequence

This section explains the operations that need to be carried out when using the recorder for the first time.

• Preparing to Record

Load the chart paper and pens (pen model) or ribbon cassette (dot model). Change the date/time if necessary.

For the operating procedure, see page 28.

• Setting the Channel Input Range and Other Parameters

Set the measurement conditions suitable for the object being measured.

This manual explains the following operations.

- Setting the input range and alarm (see page 34 for the procedure)
- Changing the chart speed (see page 43 for the procedure)

• Recording/Displaying Data

Start/Stop the recording operation and carry out various types of printouts. Also, switch the display screen and change the displayed contents.

For the operating procedure, see page 42.

Key Operation

Entering Setting Mode

Hold down the **(MENU)** key for 3 seconds.

The Setting mode display appears. The top and bottom lines are the setup item and comment, respectively.

The section that is blinking is the setup item that you change. In this manual, the section that you change appears shaded.

Setup item → `Set=Range` ← The item to be controlled blinks.
 Comment → `Input range and`

In Setting mode, the panel keys are set to the functions marked above the keys.



Exiting from Setting Mode (Returning to Operation Mode)

Hold down the **(MENU)** key for 3 seconds.

The recorder returns to operation mode.

Entering Basic Setting Mode

Hold down the **(MENU)** key for 3 seconds to enter Setting mode. Next, hold down both the **∇Δ (DISP)** key and the **<D> (FUNC)** key for 3 seconds.

The Basic Setting mode display appears. The top and bottom lines are the setup item and comment, respectively.

The section that is blinking in the setup item that you change.

Setup item → `Basic=Alarm` ← The item to be controlled blinks.
 Comment → `Auxiliary alarm`

Exiting from Basic Setting Mode (Returning to Operation Mode)

Press the **ESC (MENU)** key several times to return to the **Basic=** screen.

Press the **∇Δ (DISP)** key to select **End** and then press the **<H> (CH UP)** key. The setup save screen appears.

```
Basic=End
Save Settings
```

Press the **∇Δ (DISP)** key to select **Store** and then press the **<H> (CH UP)** key. The setting is applied, and the screen returns to Operation mode. If you select **Abort** and press the **<H> (CH UP)** key, the setting is discarded, and the screen returns to Operation mode.

```
End=Store
Save settings and
```

Changing the Settings

Note

The comment line shows useful information such as a description of the setup item and the range of selectable values. Read the comment and change the items as necessary.

The selected item change each time you press the $\nabla\Delta$ (**DISP**) key. The selected item change in reverse order if you press the $\nabla\Delta$ (**DISP**) while holding down the **SHIFT** (**FEED**) key.

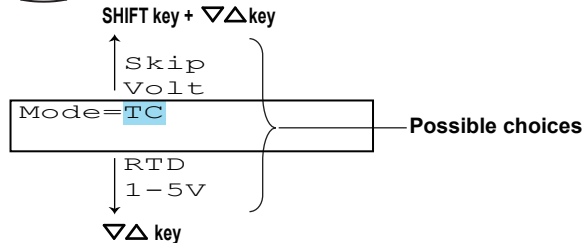

This manual denotes the operation of pressing a key while holding down the **SHIFT** (**FEED**) key as **SHIFT + the other key** (for example: **SHIFT + $\nabla\Delta$ key**).

After you make a selection, press the \leftarrow (**CH UP**) key. The next screen appears. When the **Setting complete** screen is displayed, the changed item is applied.

```
01-01 Channel
Setting complete
```

Using the ESC Key

If you press the **ESC** (**MENU**) key, the operation is cancelled, and the display returns to a higher level menu. In other words, if you do not show the **Setting complete** screen, the changes you made up to that point are discarded.

Press the **ESC** (**MENU**) key while holding down the **SHIFT** (**FEED**) key to show or hide the comment that is displayed at the bottom half of the screen.

Entering Values

Press the \leftarrow (**FUNC**) key to move the cursor to the right. Press the **SHIFT** (**FEED**) + \leftarrow (**FUNC**) to move the cursor to the left.

Press the $\nabla\Delta$ (**DISP**) key to increment the value. Press the **SHIFT** (**FEED**) + $\nabla\Delta$ (**DISP**) key to decrement the value.

You repeat these steps to enter the value.

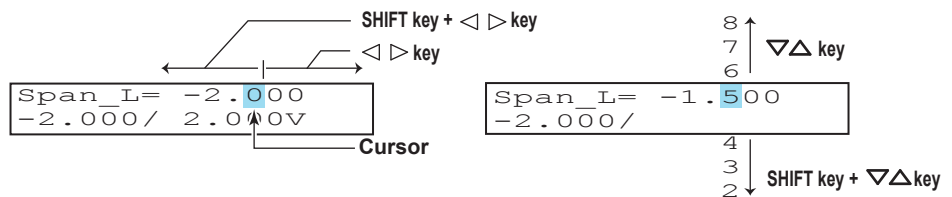

When you press the \leftarrow (**CH UP**) key, the change is applied and the next screen is displayed.

Entering Characters

Press the \leftarrow (**FUNC**) key to move the cursor to the right. Press the **SHIFT** (**FEED**) + \leftarrow (**FUNC**) to move the cursor to the left.

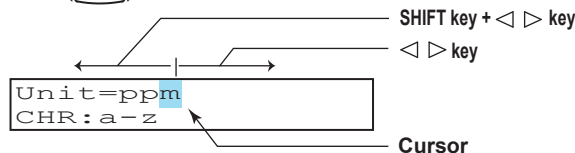

Common Operations and Menu Structure

The character type changes each time you press the **CHARACTER** (MENU) key. The character type changes in reverse order each time you press the **SHIFT** (FEED) + **CHARACTER** (MENU) key.

The character types change in the following order: uppercase alphabet (A-Z), lowercase alphabet (a-z), numbers (0-9), and symbols (%-).

A-Z	A to Z, and space
a-z	a to z, and space
0-9	0 to 9, and space
%-	%, #, °, @, +, -, *, /, (,), μ, Ω, ², ³, .., and space

The character changes each time you press the $\nabla\Delta$ (DISP) key. The character changes in reverse order each time you press the **SHIFT** (FEED) + $\nabla\Delta$ (DISP) key.

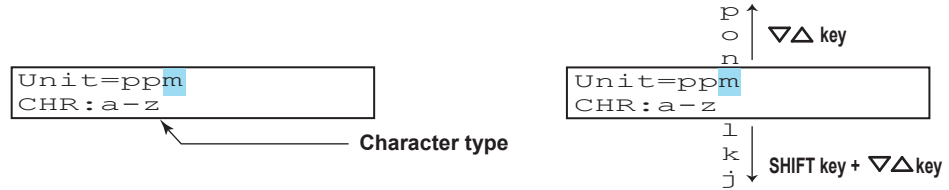

You repeat these steps to enter the character.

When you press the \leftarrow (CH UP) key, the change is applied and the next screen is displayed.

• Inserting a Character

Press the $\triangleleft \triangleright$ (FUNC) key to move the cursor to the position where the character is to be inserted.

Press the $\nabla\Delta$ (DISP) key to show **Ins DISP** and then press the $\nabla\Delta$ (DISP) key. A space for one character is inserted. Enter the character.

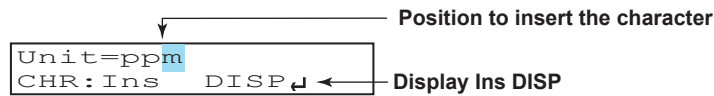

• Deleting a Character

Use the $\triangleleft \triangleright$ (FUNC) key to move the cursor to the character to be deleted.

Press the **CHARACTER** (MENU) key to show **Del DISP** and then press the $\nabla\Delta$ (DISP) key. The character is deleted.

• Deleting an Entire Character String

Press the **CHARACTER** (MENU) key to show **Clear DISP** and then press the $\nabla\Delta$ (DISP) key. The entire character string is deleted.

• Copying & Pasting a Character String

Show the copy source character string.

Press the **CHARACTER** (MENU) key to show **Copy DISP** and then press the $\nabla\Delta$ (DISP) key. The character string is saved to the memory.

Show the copy destination.

Press the **CHARACTER** (MENU) key to show **Paste DISP** and then press the $\nabla\Delta$ (DISP) key. The character string is pasted.

* When the $\triangleleft \triangleright$ (FUNC), $\nabla\Delta$ (DISP), or **CHARACTER** (MENU) key is pressed while holding down the **SHIFT** (FEED) key, the operation is reversed as when the respective key is pressed by itself.

Menu Structure of Setting Mode

References to the *µR10000 Recorder User's Manual* (IM 04P01B01-01E) are given in parentheses.

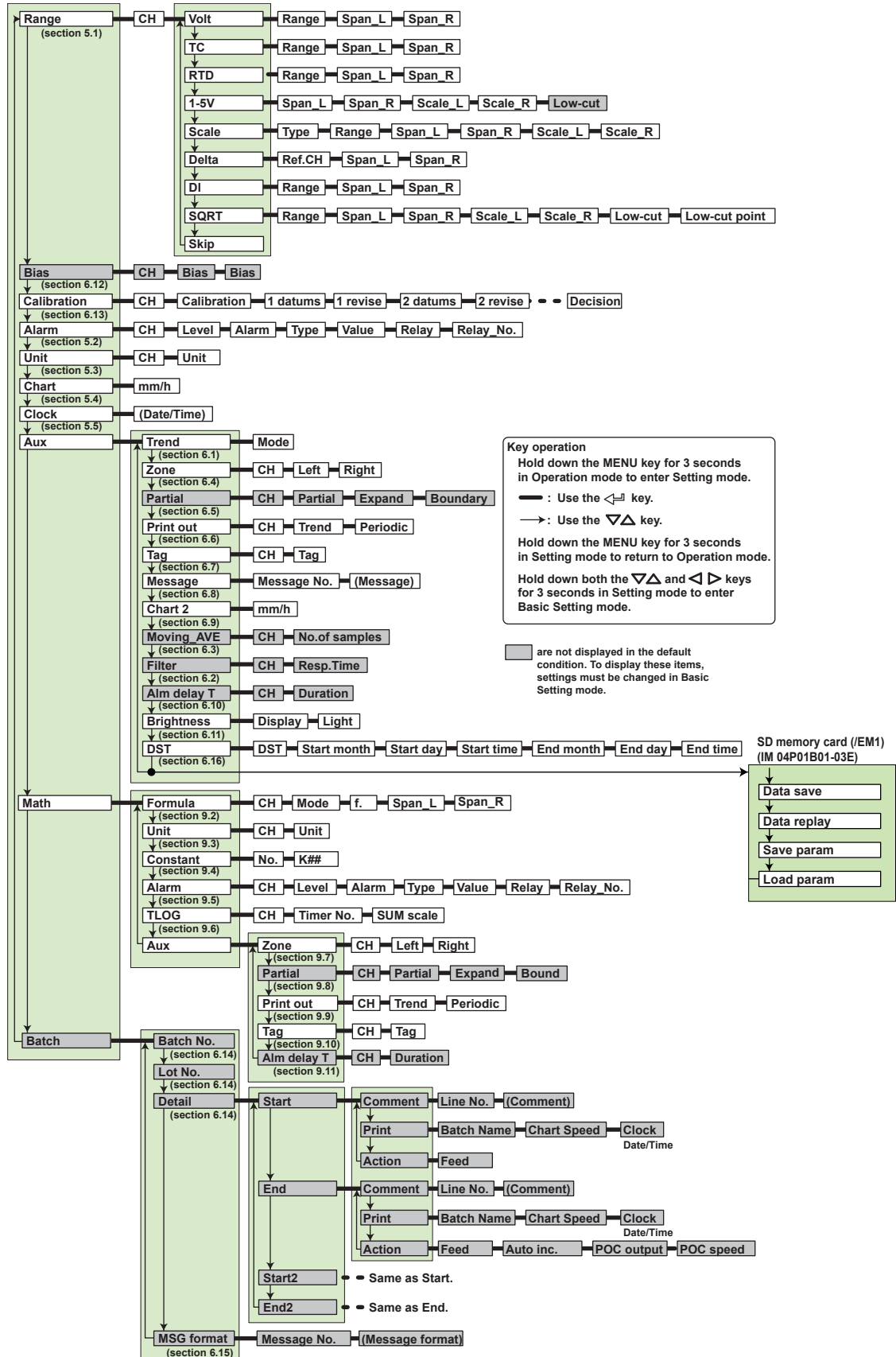

Menu Structure of Basic Setting Mode

References to the *μR10000 Recorder User's Manual* (IM 04P01B01-01E) are given in parentheses.

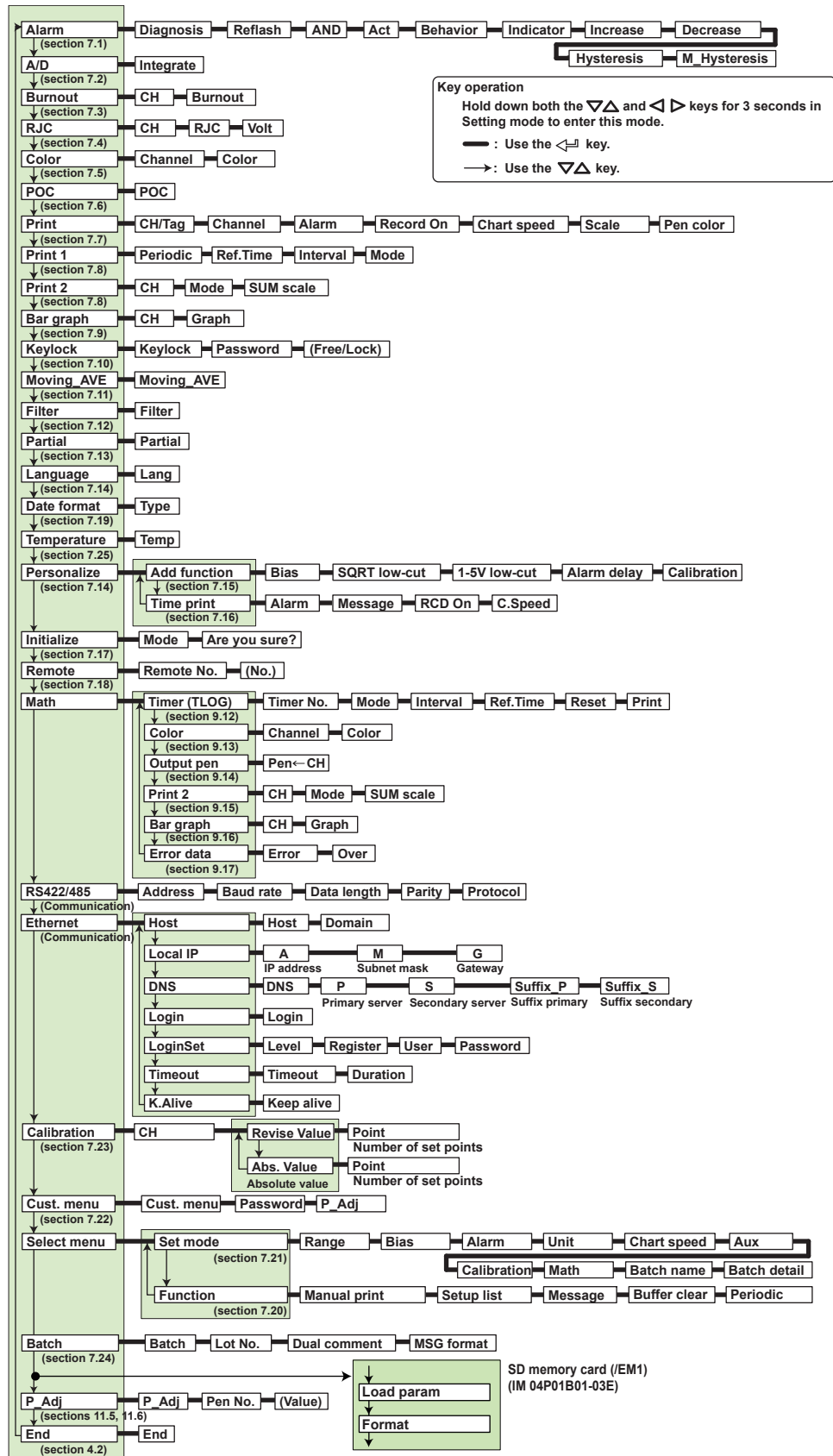

Preparing to Record

Loading or Replacing the Chart Paper

CAUTION

- Do not install or remove the chart cassette with the chart paper guide open. This may damage the stopper.
- Continuing to record or print without the chart paper on the dot model can cause damage to the chart cassette platen (the cylindrical section that holds the paper during the recording operation). Be sure to replace the chart paper ahead of time.
- When attaching the chart cassette, push it in until you hear the left and right stoppers click into place. Recordings will be inaccurate if the chart cassette is not fixed in place with stoppers.

Loading the Chart Paper

1. Open the door.

If recording is in progress, press the **RCD** key to stop the recording.

2. Remove the chart cassette.

Gently pressing the left and right stoppers inward. The bottom section of the chart cassette comes out. Gently lift the chart cassette and pull it out from the recorder case.

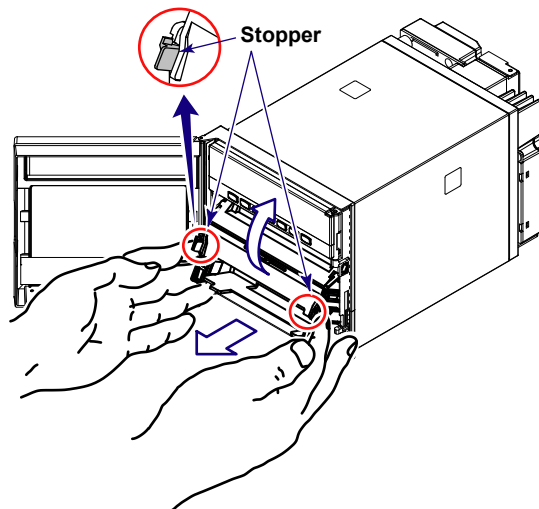

3. Open the chart holder and the chart paper guide.

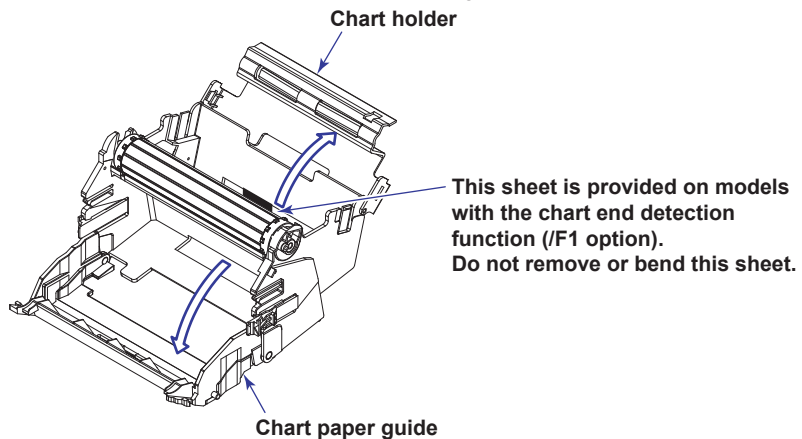

4. Load the chart paper.
Riffle the chart thoroughly before loading. Make sure that the sprocket teeth of the chart drives are properly engaged in the chart paper perforations. Make sure not to load the chart paper backwards.

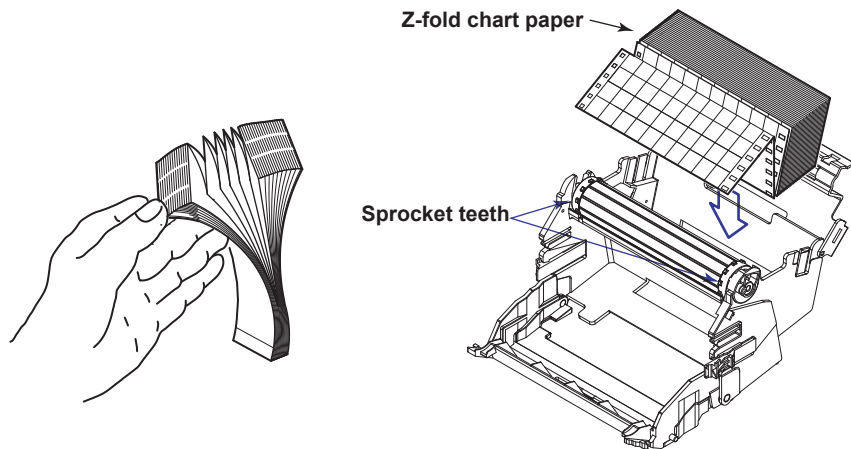

5. Close the chart holder and close the chart paper guide.

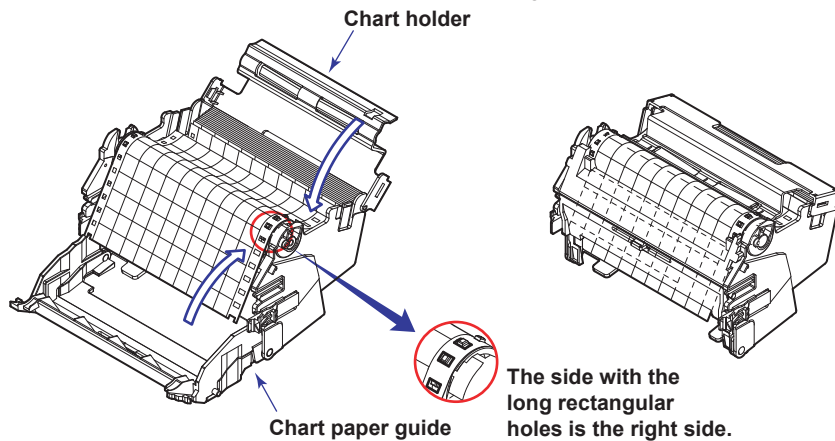

6. Replace the chart cassette back into the recorder.
Align the left and right projections with the guide grooves of the recorder and press the entire chart cassette into the recorder case. Push in the chart cassette until it is fixed in place with stoppers.

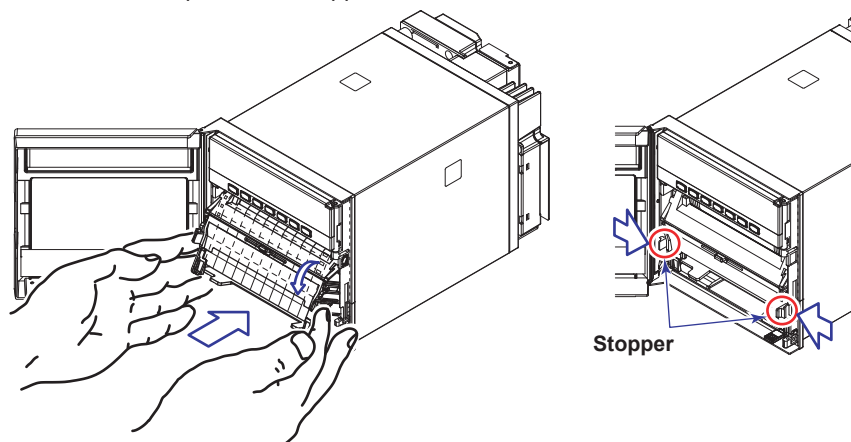

Feeding the Chart Paper

7. Press the **FEED** key to assure that the chart moves two or more folds smoothly into the chart receiver.
If it moves unsteadily, do the installing procedure again.

Installing/Replacing Felt Pens (Pen Model)

CAUTION

- Remove the chart cassette before replacing the pens. Pressing the pen tip against the chart cassette will cause the tip to deform.
- Do not press or pinch the felt tip to prevent deformation.
- Do not move the penholder left or right by force to protect the driving mechanism.
- Make sure to remove the pen cap before installation.
- Use pen caps of the same ink color. If a pen cap of a different ink color is used on the pen, the remaining ink in the cap may be absorbed through the pen tip, and the ink may change its color.
- When installing or replacing a pen, be careful not to let the ink come in contact with the eyes, mouth, or skin. If the ink enters the eyes or mouth, immediately wash with water. If the ink makes contact with your skin, immediately wash with soap and water. If you notice any abnormal symptoms, immediately consult a doctor.

1. Open the door.
If recording is in progress, press the **RCD** key to stop the recording.
2. Open the display and key panel section.
You can open the display and key panel section by holding the tab at the lower left and pulling it toward you.
3. Hold the felt pen cartridge and pull it out from the pen holder.
If the pen (pen holder) is at a position that is not easily accessible, see “When the Pen (Pen Holder) Is at a Position That Is Not Easily Accessible” below.
4. Remove the cap from the new felt pen and insert the pen firmly into the pen holder.

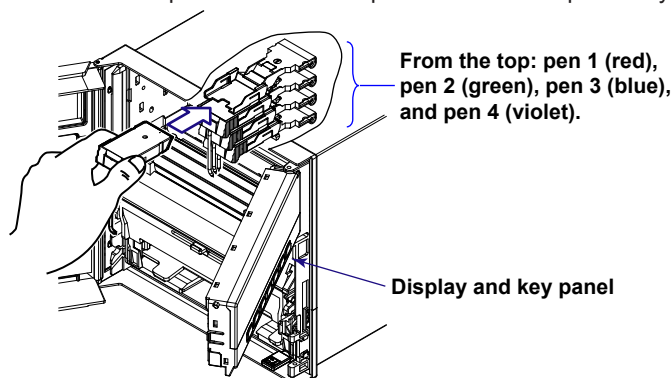

5. Return the display and key panel section to its original position.

When the Pen (Pen Holder) Is at a Position That Is Not Easily Accessible

If the pen (pen holder) is at a position that is not easily accessible, carry out the procedure below to move it near the center position.

1. Press the **FUNC** key.
2. Press the **DISP** key several times to display the **Pen exchange** screen.

Func=Pen exchange

3. Press the **CH UP** key.
The pen (pen holder) moves near the center position, and the **Pen exchange = End** screen appears.

* When the **◀▶** key or **▽△** key is pressed while holding down the **SHIFT** key, the operation is reversed as when the respective key is pressed by itself.

Note

When the pen moves, a line is drawn on the chart paper.

4. Replace the pen.
5. Return the display and key panel section to its original position, and press the \leftarrow (CH UP) key.
The screen returns to the data display screen.

Installing/Replacing the Plotter Pen (Pen Model)

1. Open the door.
If recording is in progress, press the (RCD) key to stop the recording.
2. Open the display and key panel section.
3. Hold the plotter pen cartridge and pull it out from the pen holder.
4. Remove the cap from the new plotter pen and insert the pen firmly into the pen holder.

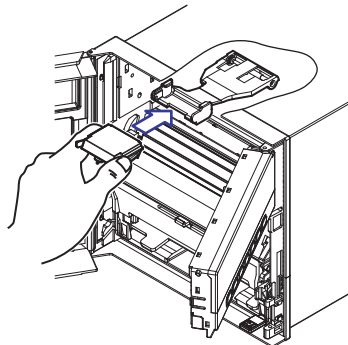

5. Return the display and key panel section to its original position.

Installing/Replacing the Ribbon Cassette (Dot Model)

CAUTION

- Improper cassette insertion may cause the color to change or damage the ribbon.
- Do not apply upward force to the printer carriage. If you do, the carriage position may be offset, and the recorder may not print correctly.
- When installing or replacing a ribbon cassette, be careful not to let the ink come in contact with the eyes, mouth, or skin. If the ink enters the eyes or mouth, immediately wash with water. If the ink makes contact with your skin, immediately wash with soap and water. If you notice any abnormal symptoms, immediately consult a doctor.

1. Open the door.
If recording is in progress, press the (RCD) key to stop the recording.
2. Press the (FUNC) key.
3. Press the $\nabla\Delta$ (DISP) key several times to display **R.exchange**.

4. Press the \leftarrow (CH UP) key.
The printer carriage moves near the center position, and **R. exchange = End** is displayed.
5. Open the display and key panel section.
You can open the display and key panel section by holding the tab at the lower left and pulling it toward you.

* When the \leftarrow \rightarrow key or $\nabla\Delta$ key is pressed while holding down the **SHIFT** key, the operation is reversed as when the respective key is pressed by itself.

Note

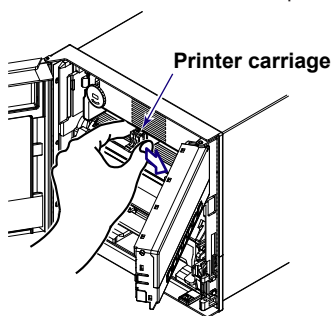
If the recorder is OFF, hold the printer carriage and move it near the center position.



6. Remove the ribbon cassette.
Pull the left-hand part of the ribbon cassette so that the cassette holder tab disengages, and pull the ribbon cassette out from the recorder case.

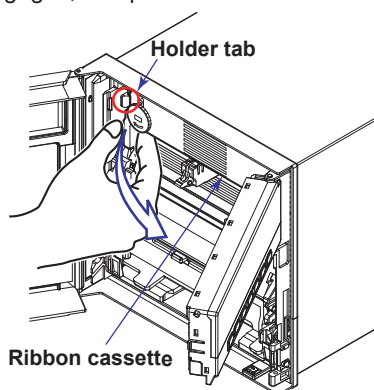

7. Take up any slack in the ribbon before installing the new ribbon cassette.
First, insert the right-hand part and then the left-hand part into the cassette holder. Check that the cassette is properly engaged with the cassette holder tab. If inserting the ribbon cassette is difficult, turn the ribbon feeding knob in the direction of the arrow to align the ribbon feeding shaft of the cassette with the ribbon feeding shaft of the holder.

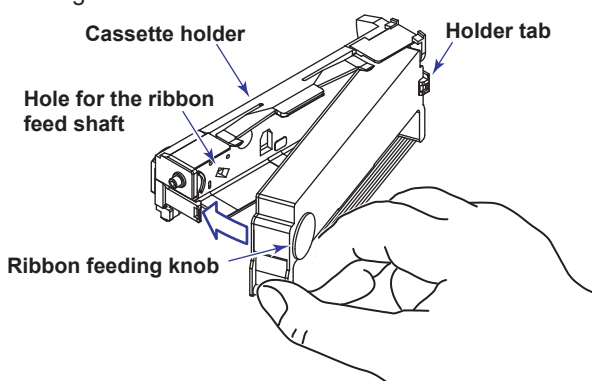

8. Return the display and key panel section to its original position, and press the \leftarrow (CH UP) key.
The screen returns to the data display screen.

Checking or Setting the Date/Time

Checking the Date/Time

The date/time is shown on the display when the **DISP** key is pressed several times.

Setting the Date/Time

1. Hold down the **MENU** key for 3 seconds to enter Setting mode.
2. Press the $\nabla\Delta$ key to show **Clock** and then press the \leftarrow key.

```
Set=Clock
```

3. Set the date and time and press the \leftarrow key.

```
04/01/17 10:39:47 ← Year/Month/Day Hour:Minute:Second
```

Press the \triangleleft key to select the desired digit. Press the $\nabla\Delta$ key to select the value.

Example: Changing from January to May in the figure below

Press the \triangleleft key three times to move the cursor to the month position. Next, press the $\nabla\Delta$ key four times to change the value from 1 to 5.

Before change	→	After change
04/01/17 10:39:47		04/05/17 10:39:47

On recorders with the version 1.02 or earlier, press the $\nabla\Delta$ key to select **Summer** (DST) or **Winter** (standard time), whichever the set time belongs to. Then press the \leftarrow key.

```
DST=Summer
```

4. When the **Setting complete** screen appears, press the **ESC/?** key.

```
Clock
Setting complete
```

5. Hold down the **MENU** key for 3 seconds to return to Operation mode.

Explanation

The date format can be changed by date format type of basic setting mode.

* When the \triangleleft key or $\nabla\Delta$ key is pressed while holding down the **SHIFT** key, the operation is reversed as when the respective key is pressed by itself.

Setting the Input Range and Alarm on Measurement Channels

Setup Example (1) of Thermocouple Input

Set channel 02 to thermocouple type K and measure temperatures in the range -50.0 to 450.0°C . The measurable range for thermocouple type K is -200.0 to 1370.0°C . The measured values in the range of -50.0 to 450.0°C are recorded in a width of 100 mm on the chart paper. This recording range is called a recording span, and the leftmost and rightmost values of the recording span are called span left and span right, respectively.

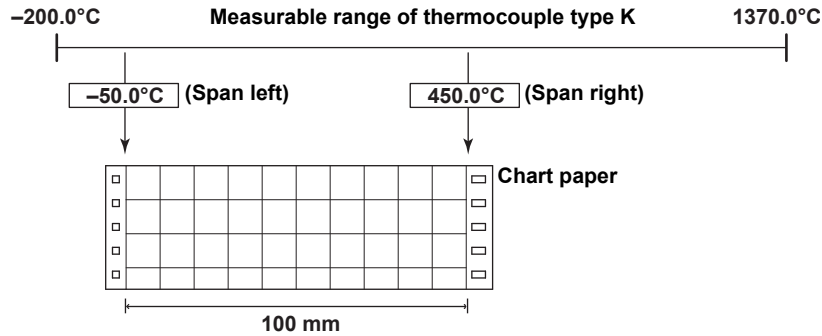

Entering Setting Mode

1. Hold down the **MENU** key for 3 seconds to enter Setting mode.

Selecting the Range

2. Press the **↵** key with **Range** shown on the screen.

```
Set=Range
Input range and
```

← Displays a description of the setup item.

Selecting the Channel Range

3. Press the **▽△** key to set the first channel to **02** and then press the **↵** key.

```
First channel Last channel
CH=02-02
First channel 01-
```

← Displays the selectable range of channels.

4. Likewise, set the last channel to **02** and then press the **↵** key.

Selecting the Input Type

5. Press the **▽△** key to select **TC** and then press the **↵** key (see "Explanation" on page 39).

```
Mode=TC
Thermocouple
```

6. Press the **▽△** key to select **K** and then press the **↵** key.

```
Range=K
R, S, B, K, E, J, T, N
```

← Displays the thermocouple type.

Setting Span Left

7. Set Span_L to **-50.0** and press the **↵** key.

Press the **◀▶** key to select the desired digit. Press the **▽△** key to select the value.

```
Span_L=-50.0
-200.0/1370.0°C
```

← Displays the measurable range of thermocouple type K.

* When the **◀▶** key or **▽△** key is pressed while holding down the **SHIFT** key, the operation is reversed as when the respective key is pressed by itself.

Selecting the Input Type

5. Press the ∇/Δ key to select **1-5V** and then press the \leftarrow key (see “Explanation” on page 39).

```
Mode=1-5V
Scales and record
```

Setting Span Left

6. Set Span_L to **1.000** and press the \leftarrow key.
Press the \leftarrow/\rightarrow key to select the desired digit. Press the ∇/Δ key to select the value.

```
Span_L= 1.000
0.800/ 1.200V ← Displays the range of Span_L.
```

Setting Span Right

7. Likewise, set Span_R to **5.000** and press the \leftarrow key.

```
Span_R= 5.000
4.800/ 5.200V ← Displays the range of Span_R.
```

Setting the Decimal Place and Scale Left

8. Display Scale_L.

```
Scale_L= 0.00
-200.00/ 300.00 ← Displays the scaling range.
```

9. Press the \leftarrow/\rightarrow key to select the desired digit.

```
Scale_L= 0.00
-200.00/ 300.00
```

10. Press the ∇/Δ key to select space and then press the \leftarrow key (Scale_L is set to **0.0**).

```
Scale_L= 0.0
-200.00/ 300.00
```

Setting Scale Right

11. Likewise, set Scale_R to **500.0** and press the \leftarrow key.

```
Scale_R= 500.0
-2000.0/ 3000.0 ← Displays the scaling range.
```

The **Setting complete** screen is displayed. When this screen is displayed, the settings entered up to then are applied.

Finishing the Settings

12. When **Setting complete** screen is displayed, press the **ESC** key.
The **Set=Range** screen is displayed.

```
03-03 Channel → Set=Range
Setting complete → Input range and
```

Setting the Unit

13. Press the ∇/Δ key to select **Unit** and then press the \leftarrow key.

```
Set=Unit ← Displays the description of setting item.
Engineering unit
```

14. Press the ∇/Δ key to set the first channel to **03** and then press the \leftarrow key.

```
First channel Last channel
↓ ↓
CH=03-03 ← Displays the selectable range of channels.
First channel 01-
```

15. Likewise, set the last channel to **03** and then press the \leftarrow key.

* When the \leftarrow/\rightarrow key or ∇/Δ key is pressed while holding down the **SHIFT** key, the operation is reversed as when the respective key is pressed by itself.

Selecting the Unit

- Use the CHARACTER key and ∇/Δ key to set **unit character** and then press the \leftarrow key. (For the procedure, see “Entering Characters” on page 24. For the characters that can be used, see “Explanation” on page 39).

```
Unit: [ ]
CHR: %-
```

Finishing the Unit Setting

- When **Setting complete** screen is displayed, press the ESC key.

```
03-03 Channel
Setting complete
```

- Hold down the MENU key for 3 seconds to return to Operation mode.

Setup Example (3) of 0 to 10 V Input

Set channel 04 to 0 to 10 V input and measure the range 0.0 to 400.0 m³/h. The 20 V DC voltage range is used. The unit is converted using the linear scaling function. The scaling range is -20000 to 30000 excluding the decimal point. The measured values in the range of 0.0 to 400.0 m³/h are recorded in a width of 100 mm on the chart paper.

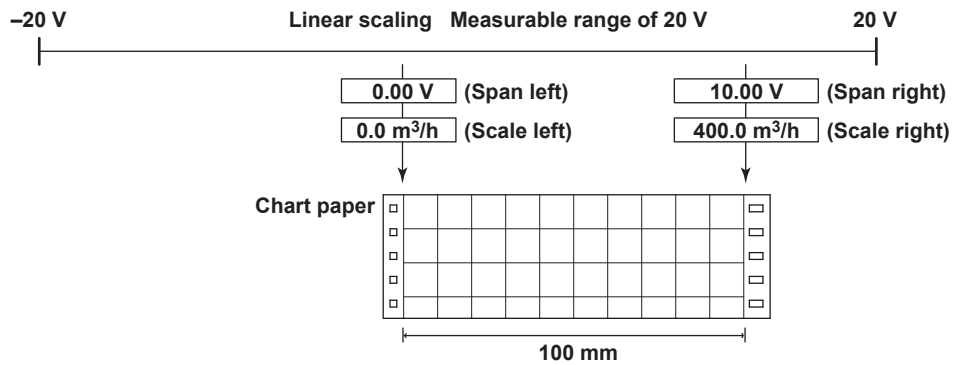

Entering Setting Mode

- Hold down the MENU key for 3 seconds to enter Setting mode.

Selecting the Range

- Press the \leftarrow key with **Range** shown on the screen.

```
Set=Range
Input range and
```

← Displays a description of the setup item.

Selecting the Channel Range

- Press the ∇/Δ key to set the first channel to **04**, and then press the \leftarrow key.

```
First channel Last channel
CH=04-04
First channel 01-
```

← Displays the selectable range of channels.

- Likewise, set the last channel to **04** and then press the \leftarrow key.

* When the \leftarrow/\rightarrow key, ∇/Δ key, or CHARACTER key is pressed while holding down the SHIFT key, the operation is reversed as when the respective key is pressed by itself.

Selecting the Input Type

5. Press the ∇/Δ key to select **Scale**, and press the \leftarrow/\rightarrow key (for the selectable settings, see “Explanation” on page 39).

```
Mode=Scale
Scales and record
```

6. Press the ∇/Δ key to select **Volt** and then press the \leftarrow/\rightarrow key.

```
Type=VOLT
DC Voltage
```

7. Press the ∇/Δ key to select **20V** and then press the \leftarrow/\rightarrow key.

```
Range=20V
20mV-50V
```

Setting Span Left

8. Set Span_L to **0.00**, and press the \leftarrow/\rightarrow key. Press the $\triangleleft/\triangleright$ key to select the desired digit. Press the ∇/Δ key to select the value.

```
Span_L= 0.00
-20.00/ 20.00V ← Displays the range of Span_L.
```

Setting Span Right

9. Likewise, set Span_R to **10.00**, and press the \leftarrow/\rightarrow key.

```
Span_R= 10.00
-20.00/ 20.00V ← Displays the range of Span_R.
```

Setting the Decimal Place and Scale Left

10. Display Scale_L.

```
Scale_L= 0.00
-200.00/ 300.00 ← Displays the scaling range.
```

11. Press the $\triangleleft/\triangleright$ key to select the desired digit.

```
Scale_L= 0.00
-200.00/ 300.00
```

12. Press the ∇/Δ key to select space and then press the \leftarrow/\rightarrow key (Scale_L is set to **0.0**).

```
Scale_L= 0.0
-200.00/ 300.00
```

Setting Scale Right

13. Likewise, set Scale_R to **400.0**, and press the \leftarrow/\rightarrow key.

```
Scale_R= 400.0
-2000.0/ 3000.0
```

The **Setting complete** screen is displayed. When this screen is displayed, the settings entered up to then are applied.

Finishing the Settings

14. When the **Setting complete** screen is displayed, press the **ESC** key. The **Set=Range** screen is displayed.

```
04-04 Channel          Set=Range
Setting complete      Input range and
```

Setting the Unit and Finishing the Unit Settings

See steps 13 to 17 in Setup Example (2).

15. Hold down the **MENU** key for 3 seconds to return to Operation mode.

* When the $\triangleleft/\triangleright$ key or ∇/Δ key is pressed while holding down the **SHIFT** key, the operation is reversed as when the respective key is pressed by itself.

Explanation

Note

If the range is changed after setting the alarm, the alarm setting becomes invalid. When you change the range, check the alarm setting.

In step 5 of setup examples (1), (2), and (3), you can select an input type or a computation type on the table below.

Mode	Description
TC	Thermocouple
RTD	Resistance temperature detector
Volt	DC voltage
DI	ON/OFF input
1-5V	1-5VDC: 1-5V is scaled to values in the appropriate unit to be used as measured values. Also, the low-cut function (input less than 0% is fixed to 0% value) can be used.
Delta	The value obtained by subtracting the measured value of another channel (called the reference channel) from the input value of the channel set to delta computation is used as the measured value of that channel.
Scale	The input values are scaled to values in the appropriate unit to be used as measured values.
SQRT	The square root of the input value is calculated, the result is scaled to a value in the appropriate unit, and used as the measured value of the channel. Also, the low-cut function (input less than a given measured value is fixed to 0) can be used.
Skip	Disables measurement, display, periodic printout, and trend recording (dot model).

• **Input Type and Measurable Range**

Thermocouple (Mode: TC)

Range Type	Measurable Range
R	0.0 to 1760.0°C
S	0.0 to 1760.0°C
B	0.0 to 1820.0°C
K	-200.0 to 1370.0°C
E	-200.0 to 800.0°C
J	-200.0 to 1100.0°C
T	-200.0 to 400.0°C
N	0.0 to 1300.0°C
W	0.0 to 2315.0°C
L	-200.0 to 900.0°C
U	-200.0 to 400.0°C
WRe	0.0 to 2400.0°C

RTD (Mode: RTD)

Range Type	Measurable Range
PT(Pt100)	-200.0 to 600.0°C
JPT(JPt100)	-200.0 to 550.0°C

DC voltage (Mode: Volt)

Range Type	Measurable Range
20mV	-20.00 to 20.00 mV
60mV	-60.00 to 60.00 mV
200mV	-200.0 to 200.0 mV
2V	-2.000 to 2.000 V
6V	-6.000 to 6.000 V
20V	-20.00 to 20.00 V
50V	-50.00 to 50.00 V

ON/OFF input (Mode: DI)

Range Type	Measurable Range
Level	0 to 1
Cont	0 to 1

Characters That Can Be Used for Units

A unit is set using up to six characters.

The available characters are as follows:

Alphabet, numbers, symbols (% , # , ° , @ , + , - , * , / , (,) , μ , Ω , ² , ³ , . ,) , and space

Setting the Alarm

Setup Example

Set a high limit alarm at 400.0°C on channel 02. The relay output (option) is not available.

Entering Setting Mode

1. Hold down the **MENU** key for 3 seconds to enter Setting mode.

Selecting the Channel

2. Press the **↵** key with **Alarm** shown on the screen.

Set=Alarm
Alarm setting ← Displays a description of the setup item.

3. Press the **▽△** key to set the first channel to **02** and then press the **↵** key.

First channel Last channel
↓ ↓
CH=01-01
First channel 01- ← Displays the selectable range of channels.

4. Likewise, set the last channel to **02** and then press the **↵** key.

Setting the Alarm Condition

5. Press the **▽△** key to select **1** and then press the **↵** key.

Up to four alarms can be set on a single channel. Each alarm is distinguished by its level: alarm level 1 to 4. In this example, alarm level 1 is used.

Level=1
1-4 ← Displays the selectable range.

6. Press the **▽△** key to select **On** and then press the **↵** key.

On: Enables the alarm of the selected alarm level.

Alarm=On
On/Off ← Displays possible choices.

7. Press the **▽△** key to select **H** and then press the **↵** key.

The letter "H" represents the high limit alarm (see "Explanation").

Type=H
High limit alarm ← Displays a description of the selected type.

8. Set the alarm value to **400.0** by carrying out the key operations below.

Press the **◀▶** key to select the desired digit. Press the **▽△** key to select the value.

When all digits have been set, press the **↵** key.

Value= 1.000
-200.0/ 1370.0°C ← Displays the measurable range of the input range specified on the channel.

Setting the Relay Output

Output alarms on the relay I01. This setting is valid only on models with the /A1, /A2, or /A3 option.

9. Press the **▽△** key to select **On** and then press the **↵** key.

Relay=On
On/Off ← Displays possible choices.

* When the **◀▶** key or **▽△** key is pressed while holding down the **SHIFT** key, the operation is reversed as when the respective key is pressed by itself.

Setting the Input Range and Alarm on Measurement Channels

10. Press the ∇/Δ key to select **I01** and then press the \leftarrow/\rightarrow key.

```
Relay_No. = I01
```

The **Setting complete** screen is displayed. When this screen is displayed, the settings entered up to then are applied.

Finishing the Settings

11. When **Setting complete** screen is displayed, do either of the following:
Press the \leftarrow/\rightarrow key to set other alarms.
To finish setting the alarm, press the **ESC** key.

```
02-02 CH/level 1  
Setting complete
```

12. Hold down the **MENU** key for 3 seconds to return to Operation mode.

Explanation

In step 7, you can select an alarm type on the table below.

Type	Description
H	High Limit Alarm: An alarm occurs when the input value exceeds the alarm value.
L	Low Limit Alarm: An alarm occurs when the input value falls below the alarm value.
h	Difference High Limit Alarm*: An alarm occurs when the difference in the input values of two channels is greater than or equal to the specified value.
l	Difference Low Limit Alarm*: An alarm occurs when the difference in the input values of two channels is less than or equal to the specified value.
R	High Limit on Rate-of-Change Alarm**: The rate-of-change of the measured values is checked over a certain time (interval). An alarm occurs if the rate-of-change of the measured value in the rising direction is greater than or equal to the specified value.
r	Low Limit on Rate-of-Change Alarm**: The rate-of-change of the measured values is checked over a certain time (interval). An alarm occurs if the rate-of-change of the measured value in the falling direction is greater than or equal to the specified value.
T	Delay High Limit Alarm***: An alarm occurs when the measured value remains above the alarm value for a specified time period (alarm delay period).
t	Delay Low Limit Alarm***: An alarm occurs when the measured value remains below the alarm value for a specified time period (alarm delay period).

* Can be specified on channels set to delta computation.

** You must set the interval in Basic Setting mode.

*** You can select T or t when the alarm delay function is enabled in Basic Setting mode.

* When the \leftarrow/\rightarrow key or ∇/Δ key is pressed while holding down the **SHIFT** key, the operation is reversed as when the respective key is pressed by itself.

Recording/Displaying Data

Starting the Recording

Press the **RCD** key to start recording.
The status display shows the word "RECORD."

Note

For models with the FAIL/chart end detection and output function (/F1 option), the chart feed will not start even when pressing the RCD key if the chart paper is empty or almost out. Insert new chart paper before pressing the RCD key.

Recording Example (Pen Model)



Recording Example (Dot Model)

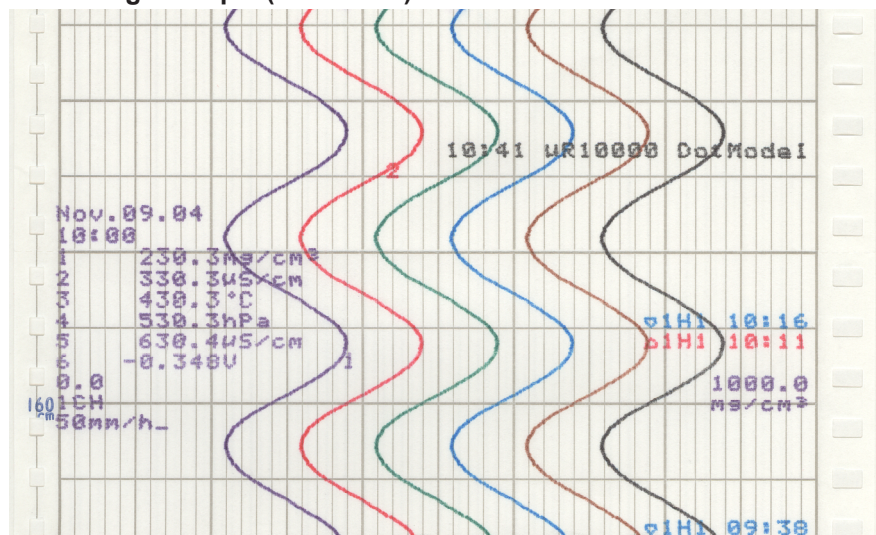

The recording examples may appear differently from the actual recording as a result of functional improvements made on the recorder after this manual was written.

Stopping the Recording

While recording is in progress, press the **RCD** key to stop recording.
The word "RECORD" on the status display clears.

Feeding the Chart Paper Manually

The chart paper is fed while the **FEED** key is held down.

Changing the Chart Speed

1. Hold down the **MENU** key for 3 seconds to enter Setting mode.
2. Press the $\nabla\Delta$ key to show **Chart** and then press the \leftarrow key.

Set=Chart
Chart speed ← Displays a description of the setup item.

3. Set the chart speed and press the \leftarrow key.

mm/h= 20 ← Current chart speed.
1/1500mm/h ← Displays the range that can be specified. (Display example on the dot model)

On the pen model, press the $\nabla\Delta$ key to select the chart speed.

Chart speed on the pen model (unit: mm/h)

5	6	8	9	10	12	15	16	18	20
24	25	30	32	36	40	45	48	50	54
60	64	72	75	80	90	96	100	120	125
135	150	160	180	200	225	240	250	270	300
320	360	375	400	450	480	500	540	600	675
720	750	800	900	960	1000	1080	1200	1350	1440
1500	1600	1800	2000	2160	2250	2400	2700	2880	3000
3600	4000	4320	4500	4800	5400	6000	7200	8000	9000
10800	12000								

On the dot model, enter a value to set the chart speed. The chart speed can be set in the range of 1 to 1500 mm/h in 1 mm steps.

Press the $\triangleleft \triangleright$ key to select the desired digit. Press the $\nabla\Delta$ key to select the value.

4. When the **Setting complete** screen appears, the new chart speed is applied.

Chart speed
Setting complete

Press the **ESC** key to change the chart speed again.

Hold down the **MENU** key for 3 seconds to return to Operation mode.

Viewing the Recorded Results

Pull the front cover tab of the chart cassette to open the front cover. The recorded chart paper can be pulled out for viewing.

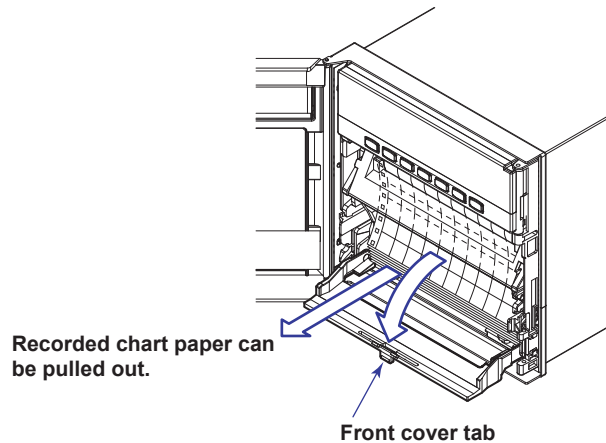

* When the $\triangleleft \triangleright$ key or $\nabla\Delta$ key is pressed while holding down the **SHIFT** key, the operation is reversed as when the respective key is pressed by itself.

Description of the Printout Contents

Printout Description Figure (Pen Model)

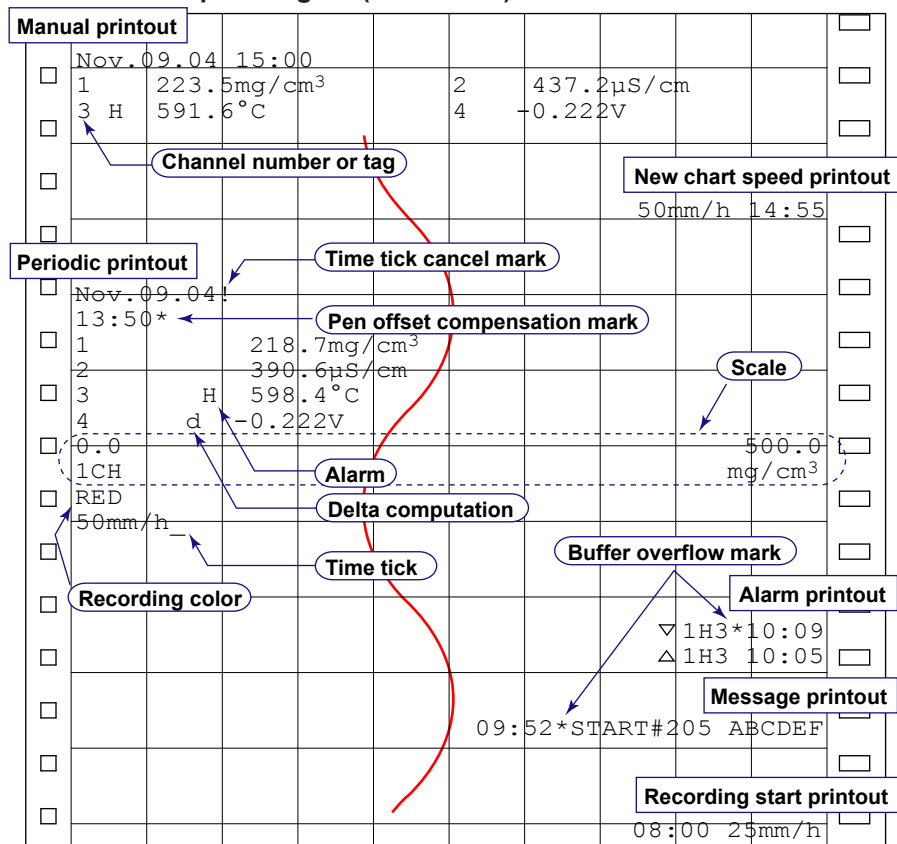

Printout Description Figure (Dot Model)

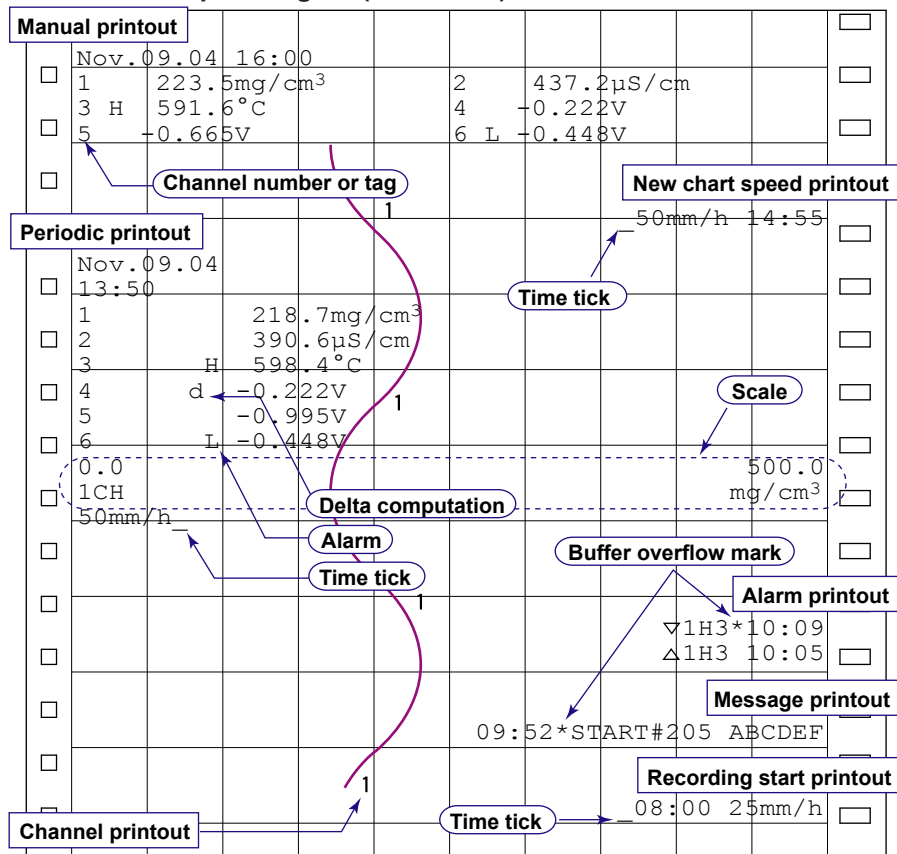

The printout description figures are for explaining the printout contents. The font is different from the actual printout. The printout positions are also slightly different.

- **Manual Printout**
Prints the current measured values and alarm statuses of all channels by operating the keys.
- **New Chart Speed Printout**
When the chart speed is changed, the time tick (dot model), the date/time of change, and the new chart speed are printed. The time ticks are marks that indicate the positions of the date/time on the chart paper. An asterisk (*) shows there are messages that cannot be printed.
- **Periodic Printout**
Measured values and other items are printed at the preset interval. For details, see appendixes 1 and 2 in the *μR10000 Recorder User's Manual*, IM 04P01B01-01E.
 - **Printout Contents**
The date/time, time tick, measured value and channel status for each channel, the channel scale (the leftmost and rightmost values of the span), and the chart speed are printed. On the pen model, if a time tick is not printed at the correct position, a time tick cancel mark (!) is printed. Pen offset compensation mark is printed when the function to compensate the pen offset along the time axis is enabled.
 - **Printout Interval**
The printout interval can be set by specifying the value or set automatically in sync with the chart speed.

Alarm Printout

Alarm information is printed when an alarm occurs or releases.

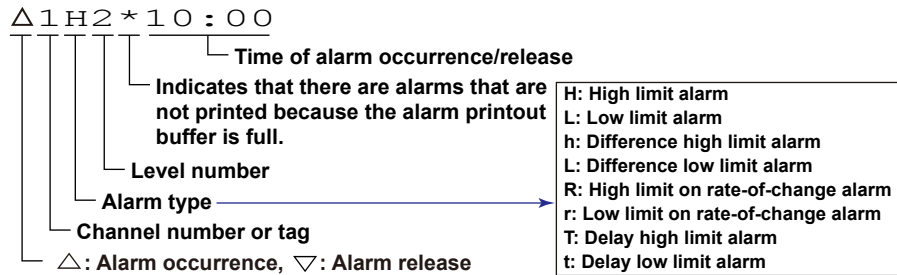

Alarms that occur while an alarm printout is in progress are temporarily saved to the buffer memory in a printout-wait condition. Alarms are cleared from the buffer memory when they are printed. A buffer overflow mark is printed when there are alarms that cannot be printed because the buffer is full.

- **Message Printout**
An arbitrary character string from five character strings set in advance can be printed on the chart paper. Each message can be set using up to 16 characters. If message printout is executed while another message is being printed, the most recent message is temporarily stored to the buffer memory in a printout-wait condition. Messages are cleared from the buffer memory when they are printed. A buffer overflow mark is printed when there are messages that cannot be printed because the buffer is full.
- **Recording Start Printout**
When recording is started, the time tick (dot model), the time, and the chart speed can be printed. By factory default, the recording start printout is disabled. An asterisk (*) shows there are messages that cannot be printed.
- **Channel Printout (Dot Model)**
Prints the channel number or tag by the trend recording.

Characters may become discolored or the ribbon may brush against the paper due to the warping of the ink ribbon or the like during a digital printout. These do not occur during analog recording.

Digital printout type: periodic printout, alarm/message printout, channel printout

Switching the Display Screen

The screen switches each time the **[DISP]** key is pressed. Screen 01 through 15 are switched in order. Screens that are set to "Skip" (See "Display Types" on the next page) are skipped. Below is a display example.

Display Example (1-channel digital + bar graph display)

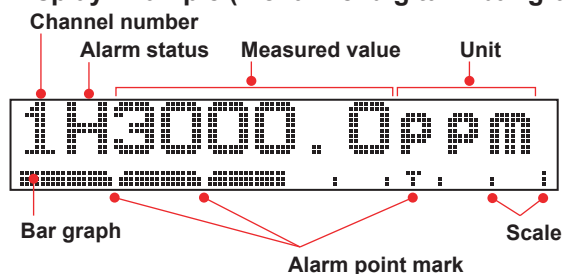

- **Channel Auto Switching**

On screens that show the measured values and computed values, the displayed channel is automatically switched in ascending order. The switching interval can be set to 1 s, 2 s, 3 s, 4 s, or 5 s.

- **Switching the Displayed Channel Using Keys**

If Manual switching is specified, the channel switches each time the **[CH UP]** key is pressed in ascending order. All channels are displayed in order.

Display Example (Flag Display)

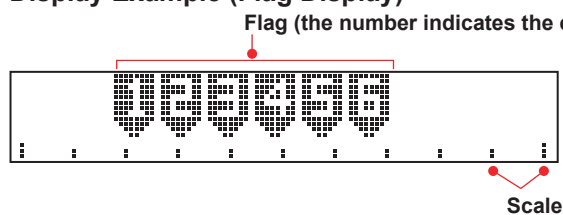

Display Example (Alarm Status Display)

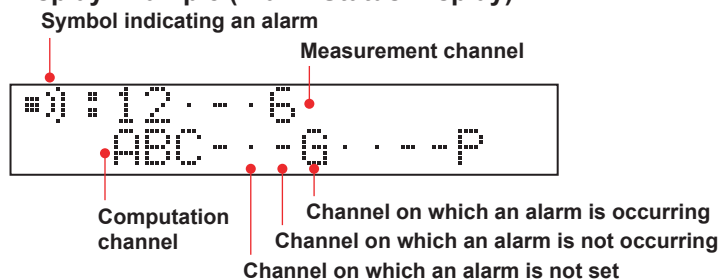

Display Example (Date/Time and Chart Speed Display)

The date format can be specified.

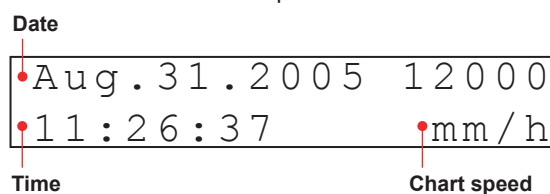

Display Example (Status Display)

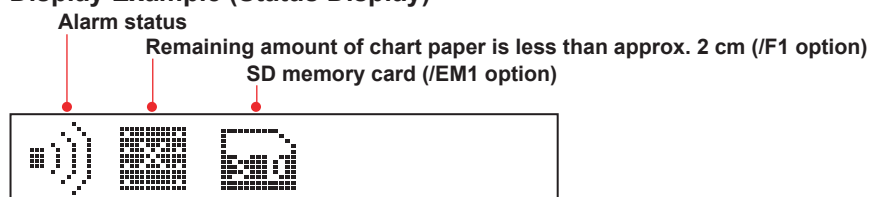

Changing the Displayed Information

Different display types can be registered to screens 01 to 15. As an example, the procedure of assigning 1-channel digital display (tag display) to screen 02 is explained below.

1. Hold the **MENU** key for 3 seconds to show the data display setup screen.

Selecting the Screen Number

2. Press the **▽△** key to select screen number **02** and then press the **↵** key.



A sample screen of the display type appears. A section of the display blinks to indicate that this is a data display setup screen.

Selecting the Display Type

3. Press the **▽△** key to switch the display. Select the **TAG001A** (Tag_1CH digital) display and then press the **↵** key.

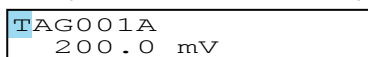

4. Press the **▽△** key to set the channel switching interval and then press the **↵** key.
Interval: Sets the channel switching interval. Select the interval from 1 s, 2 s, 3 s, 4 s, 5 s, and manual.

Auto1s, Auto2s, Auto3s, Auto4s, Auto5s:

Switches the displayed channel at the specified time interval.

Manual: Switch the displayed channel using a key (**CH UP**).

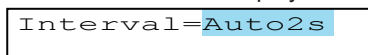

5. When the **Setting complete** screen appears, the new setting is applied.



Press the **↵** key to register display types to other screens.

Hold the **MENU** key down for 3 seconds to exit from the data display setup screen.

Display Types

Display types listed below are available besides the types on previous page.

1CH digital display 	2CH digital display 	4CH digital display
6CH digital display (Dot model) 	2CH digital + 2CH bargraph display 	1CH digital + 4CH bargraph display (Pen model)
4CH bargraph display (Pen model) 	6CH bargraph display (Dot model) 	DI/DO display
Multiple display (Different screens can be assigned to top and bottom sections)	Tag_1CH digital display 	Tag_2CH digital display
Tag_1CH digital + 1CH bargraph display 	Tag_1CH digital + 1CH bargraph display (Pen model) 	System display Switches the displayed contents every 3 seconds. Displays number of measurement inputs, optional functions, version number, etc.
Batch name display 	SD memory card info Switches the displayed contents every 3 seconds.	Off No display Skip No display type is registered. Skips the screen during screen switching.

* When the **◀▶** key or **▽△** key is pressed while holding down the **SHIFT** key, the operation is reversed as when the respective key is pressed by itself.

FUNC Key Operations in Operation Mode

The operations below can be carried out with the FUNC key in Operation mode. References to the *µR10000 Recorder User's Manual* (IM 04P01B01-01E) are given in parentheses.

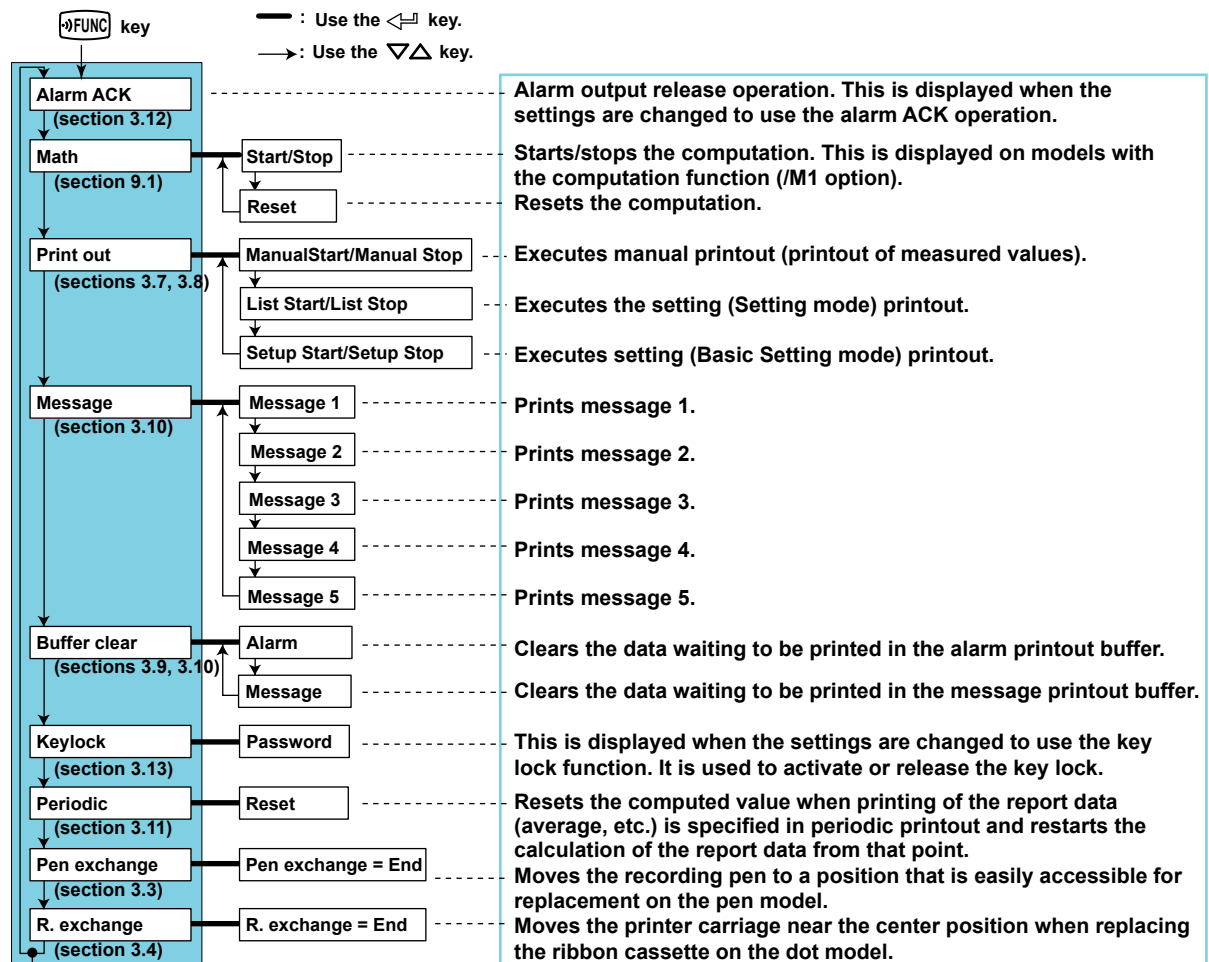

With the SD memory card (/EM1 option), "Data save," "Data replay," "SD card" (Eject) menu items are added.

Printing Measured Values (Manual Printout)

The measured values of all channels are printed.

Starting the Manual Printout

1. Press the FUNC key.
The **Func=** screen appears.
2. Press the ∇/Δ key to select **Print out** and then press the \leftarrow key.

```
Func=Print out
```
3. Press the \leftarrow key with **ManualStart** shown on the screen.
Manual printout starts. The screen returns to the data display screen.

```
Print=ManualStart
```

Note

- When manual printout is executed, trend recording is suspended. However, the recorder continues the measurement and alarm detection (in the background).
- When manual printout is complete, trend recording resumes.
- If an alarm occurs during the manual printout, the alarm is printed after the recording resumes.

* When the \leftarrow/\rightarrow key or ∇/Δ key is pressed while holding down the **SHIFT** key, the operation is reversed as when the respective key is pressed by itself.

Aborting the Manual Printout

1. Press the **FUNC** key.
2. Press the **▽△** key to select **Print out** and then press the **↵** key.
3. Press the **↵** key with **Manual Stop** shown on the screen.
Manual printout stops. The screen returns to the data display screen.

Print=Manual Stop

Printing the Recorder Settings

This section explains the procedure for printing the recorder settings. There are two sets of settings that can be printed: List and Setup.

List: Prints the settings of Setting mode (input range for each channel, etc.)

Setup: Prints the settings of Basic Setting mode

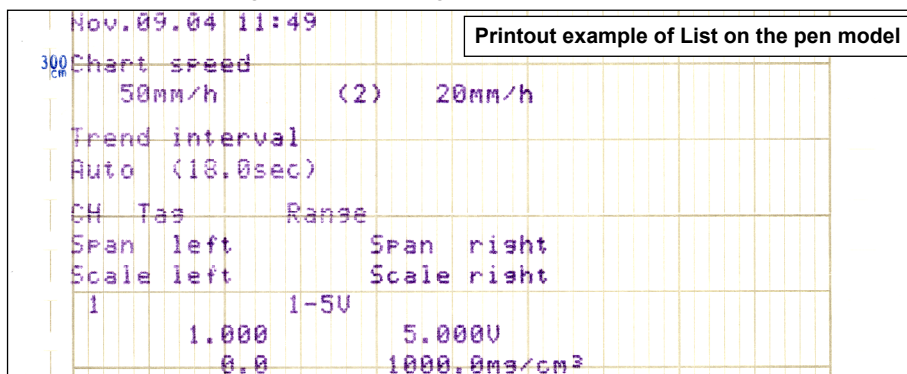

Note

- The printout takes several minutes to tens of minutes to complete.
- When printout is executed, trend recording is suspended. However, the recorder continues the measurement and alarm detection (in the background).
- When printout is complete, trend recording resumes.
- If an alarm occurs during the printout, the alarm is printed after the recording resumes.

Starting the List Printout

1. Press the **FUNC** key.
2. Press the **▽△** key to select **Print out** and then press the **↵** key.
3. Press the **↵** key to show **List Start** and then press the **↵** key.
The List printout starts. The screen returns to the data display screen.

Func=Print out

Print=List Start

Aborting the List Printout

1. Press the **FUNC** key.
2. Press the **▽△** key to select **Print out** and then press the **↵** key.
3. Press the **▽△** key to show **List Stop** and then press the **↵** key.
The List printout stops. The screen returns to the data display screen.

Print=List Stop

Starting/Stopping the Setup Printout

Setup printout can be started/stopped in a similar fashion to List printout. For Setup printout, select **Setup Start** and **Setup Stop**.

* When the **◀▶** key or **▽△** key is pressed while holding down the **SHIFT** key, the operation is reversed as when the respective key is pressed by itself.

Clearing the Alarm Printout Buffer

Alarm information waiting to be printed is temporarily stored in the buffer memory. This operation clears all of the alarm information in the buffer. This function can be used to prevent unneeded alarm printouts from being executed.

1. Press the **FUNC** key.
2. Press the **▽△** key to select **Buffer clear** and then press the **↵** key.

```
Func=Buffer clear
```

3. Press the **↵** key with **Alarm** shown on the screen.
The data in the alarm printout buffer is cleared. The screen returns to the data display screen.

```
Buf.clear=Alarm
```

Printing a Message

This section explains the procedure for printing the preset character strings. For details on setting the character strings, see section 6.8, "Setting the Message String" in the *μR10000 Recorder User's Manual* (IM 04P01B01-01E).

Note

- Messages can be printed only during trend recording. However, regardless of whether trend recording is in progress or not, messages waiting to be printed are temporarily stored in the buffer memory.
- Message printouts are not performed when the chart speed is greater than or equal to 1600 mm/h and 101 mm/h on the pen model and dot model, respectively.

Printing a Message

1. Press the **FUNC** key.
2. Press the **▽△** key to select **Message** and then press the **↵** key.

```
Func=Message
```

3. Press the **▽△** key to select the message number and then press the **↵** key.
The message printout starts. The screen returns to the data display screen.

```
Message=Message1
```

← Displays the preset message.

Clearing the Message Printout Buffer

Messages waiting to be printed are temporarily stored in the buffer memory. This operation clears the messages in the buffer.

1. Press the **FUNC** key.
2. Press the **▽△** key to select **Buffer clear** and then press the **↵** key.
3. Press the **▽△** key to select **Message** and then press the **↵** key.
The data in the message printout buffer is cleared. The screen returns to the data display screen.

```
Buf.clear=Message
```

* When the **◀▶** key or **▽△** key is pressed while holding down the **SHIFT** key, the operation is reversed as when the respective key is pressed by itself.

Releasing the Alarm Output (Alarm ACK Operation)

This operation releases the alarm indication or relay output (/A1, /A2, or /A3 option) when the alarm indication or output relay is set to hold operation. For details on the hold operation, see section 1.3, "Alarms," in the *μR10000 Recorder User's Manual* (IM 04P01B01-01E).

1. Press the **FUNC** key.
2. Press the **ENTER** key with **Alarm ACK** shown on the screen.
The alarm indication or relay output is released. The screen returns to the data display screen.

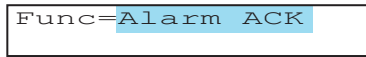

Description

Alarm ACK Operation and the Actions of the Alarm Output Relay/Alarm Display

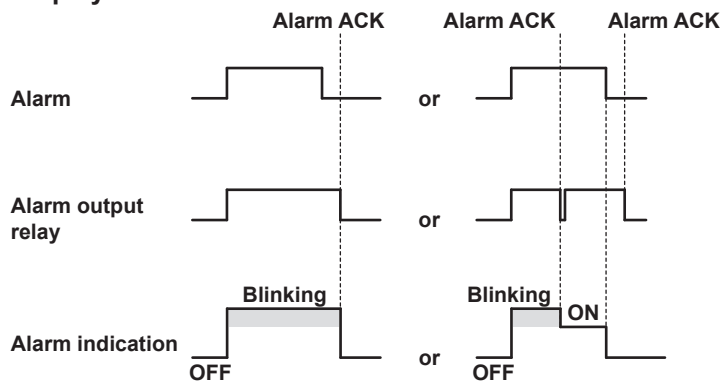

Activating/Releasing the Key Lock

When the recorder is configured to use the key lock function, this operation activates or releases the key lock. For details on setting the key lock function, see section 7.10, "Setting the Key Lock Function," in the *μR10000 Recorder User's Manual* (IM 04P01B01-01E).

Activating the Key Lock

1. Press the **FUNC** key.
2. Press the **▽△** key to select **Keylock** and then press the **ENTER** key.
The key lock is activated. The screen returns to the data display screen.

Releasing the Key Lock

Note

A password is required to release the key lock.

1. Press the **FUNC** key.
2. Press the **▽△** key to select **Keylock** and then press the **ENTER** key.
3. Enter the password for releasing the key lock.
The password values are shown with asterisks.
Press the **◀▶** key to select the desired digit. Press the **▽△** key to select the value.

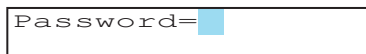

4. Press the **ENTER** key.
The key lock is released. The screen returns to the data display screen.

* When the **◀▶** key or **▽△** key is pressed while holding down the **SHIFT** key, the operation is reversed as when the respective key is pressed by itself.

Setup Items and Default Values

Setup Items in Setting Mode and Their Default Values

The items with an asterisk are not displayed in the default condition. To display these items, settings must be changed in Basic Setting mode.

Setup Item	Pen/Dot	Selectable Range or Selections	Default Value
Range > CH	-	01 to 06	01
Range > Mode	-	Volt/TC/RTD/1-5V/Scale/Delta/DI/SQRT/Skip	Volt
Range > Mode > Range	-	20mV/60mV/200mV/2V/6V/20V/50V/1-5V/ R/S/B/K/E/J/T/N/W/L/U/WRe/Pt/JPt/Level/Cont/ (Selections for /N1 and /N3 options)	2V
*Bias > CH	-	01 to 06	01
*Bias > Bias	-	On/Off	Off
*Bias > Bias	-	±10 % of the span of the measurable range or the scaling span	-
Calibration (/CC1 option)			
Calibration > CH	-	01 to 06	01
Calibration > Calibration	-	On/Off	Off
Calibration > datums	-	Within the range	-
Calibration > revise	-	Within the range (correction point + correction value for revise value)	-
Calibration > Decision	-	Yes/No	Yes
Alarm > CH	-	01 to 06	01
Alarm > Level	-	1/2/3/4	1
Alarm > Alarm	-	On/Off	Off
Alarm > Type	-	H/L/h/l/R/r (*T/t)	H
Alarm > Value	-	Depends on the alarm type.	-
Alarm > Relay	-	On/Off	Off
Alarm > Relay No.	-	I01 to I06	I01
Unit > CH	-	01 to 06	01
Unit > Unit	-	6 characters or less	Blank
Chart	Pen Model	82 types (pen model)	20 mm/h
	Dot Model	1 to 1500 mm/h (dot model)	20 mm/h
Clock	-	Date/Time	-
Aux > Trend	Dot Model	Auto/Fix	Auto
Aux > Zone > CH	-	01 to 06	01
Aux > Zone > Left, Right	-	Within the recording span range (mm)	Left: 0, Right: 100
*Aux > Partial > CH	-	01 to 06	01
*Aux > Partial > Partial	-	On/Off	Off
*Aux > Partial > Expand	-	1 to 99%	50
*Aux > Partial > Boundary	-	Within the recording span range	-
Aux > Print out > CH	-	01 to 06	01
Aux > Print out > Trend	Dot Model	On/Off	On
Aux > Print out > Periodic	-	On/Off	On
Aux > Tag > CH	-	01 to 06	01
Aux > Tag > Tag	-	7 characters or less	1 to 6
Aux > Message > Message No.	-	1 to 5	1
Aux > Message > (Message)	-	16 characters or less	Blank
Aux > Chart2	Pen Model	82 types (pen model)	20 mm/h
	Dot Model	1 to 1500 mm/h (dot model)	20 mm/h
*Aux > Moving_AVE > CH	Dot Model	01 to 06	01
*Aux > Moving_AVE > No. of samples	Dot Model	Off, 2 to 16	Off
*Aux > Filter > CH	Pen Model	01 to 06	01
*Aux > Filter > Resp. Time	Pen Model	2s/5s/10s	Off
*Aux > Alm delay T > CH	-	01 to 06	01
*Aux > Alm delay T > Duration	-	0 to 3600s	10s
Aux > Brightness > Display	-	1/2/3/4/5/6/7/8	4
Aux > Brightness > Light	-	1/2/3/4	2
Aux > DST	-	Not/Use	Not
Aux > DST > Start month	-	Apr/May/June/July/Aug/Sep/Oct/Nov/Dec/Jan/ Feb/Mar	Apr

Setup Items and Default Values

Setup Item	Pen/Dot	Selectable Range or Selections	Default Value
Aux > DST > Start day	-	1st-Sun/.../Last-Mon	1st-Sun
Aux > DST > Start time	-	0:00 to 23:00	0:00
Aux > DST > End month	-	Apr/May/June/July/Aug/Sep/Oct/Nov/Dec/Jan/ Feb/Mar	Apr
Aux > DST > End day	-	1st-Sun/.../Last-Mon	Last-Mon
Aux > DST > End time	-	0:00 to 23:00	0:00
SD card (/EM1 option)			
Aux > Data save > Start, Stop	-	Func menu > Record > Batch	Func menu
> Data replay > Mode	Dot Model	Original/Current	Original
> Save param > File	-	Up to 17 characters	-
> Load param > File	-	Search text	-
Math (/M1 option)			
Math > Formula > CH	-	0A/0B/0C/0D/0E/0F/0G/0J/0K/0M/0N/0P	0A
Math > Formula > Mode	-	On/Off	Off
Math > Formula > f.	-	120 characters or less	01
Math > Unit > CH	-	0A/0B/0C/0D/0E/0F/0G/0J/0K/0M/0N/0P	0A
Math > Unit > Unit	-	6 characters or less	Blank
Math > Constant > No.	-	K01 to K30	K01
Math > Alarm > CH	-	0A/0B/0C/0D/0E/0F/0G/0J/0K/0M/0N/0P	0A
Math > Alarm > Level	-	1/2/3/4	1
Math > Alarm > Alarm	-	On/Off	Off
Math > Alarm > Type	-	H/L (*T/t)	H
Math > Alarm > Value	-	-9999999 to 99999999 excluding the decimal	-
Math > Alarm > Relay	-	On/Off	Off
Math > Alarm > Relay No.	-	I01 to I06	I01
Math > TLOG > CH	-	0A/0B/0C/0D/0E/0F/0G/0J/0K/0M/0N/0P	0A
Math > TLOG > Timer No.	-	Periodic/1/2	Periodic
Math > TLOG > SUM scale	-	Off, /s, /min, /h, /day	Off
Math > Aux > Zone > CH	-	0A/0B/0C/0D/0E/0F/0G/0J/0K/0M/0N/0P	0A
Math > Aux > Zone > Left, Right	-	Within the recording span range (mm)	Left: 0, Right: 100
*Math > Aux > Partial > CH	-	0A/0B/0C/0D/0E/0F/0G/0J/0K/0M/0N/0P	0A
*Math > Aux > Partial > Partial	-	On/Off	Off
*Math > Aux > Partial > Expand	-	1 to 99%	50
*Math > Aux > Partial > Bound	-	Within the recording span range	-
Math > Aux > Print out > CH	-	0A/0B/0C/0D/0E/0F/0G/0J/0K/0M/0N/0P	0A
Math > Aux > Print out > Trend	Dot Model	On/Off	On
Math > Aux > Print out > Periodic	-	On/Off	On
Math > Aux > Tag > CH	-	0A/0B/0C/0D/0E/0F/0G/0J/0K/0M/0N/0P	0A
Math > Aux > Tag > Tag	-	7 characters or less	A to P
*Math > Aux > Alm delay T > CH	-	0A/0B/0C/0D/0E/0F/0G/0J/0K/0M/0N/0P	0A
*Math > Aux > Alm delay T > Duration	-	0 to 3600s	10s
Batch (/BT1 option)			
*Batch > Batch No	-	26 characters or less	Blank
*Batch > Lot No.	-	0000-9999 or 000000-999999	0000 or 000000
*Batch > Detail > Start > Comment > Line No.	-	1/2/3/4/5	1
*Batch > Detail > Start > Comment > (Comment)	-	32 characters or less	Blank
*Batch > Detail > Start > Print > Batch Name	-	On/Off	On
*Batch > Detail > Start > Print > Chart Speed	-	On/Off	On
*Batch > Detail > Start > Print > Clock	-	On/Off	On
*Batch > Detail > Start > Action > Feed	-	0 to 50 mm	0 mm
*Batch > Detail > End > Comment > Line No.	-	1/2/3/4/5	1
*Batch > Detail > End > Comment > (Comment)	-	32 characters or less	Blank
*Batch > Detail > End > Print > Batch Name	-	On/Off	On
*Batch > Detail > End > Print > Chart Speed	-	On/Off	On
*Batch > Detail > End > Print > Clock	-	On/Off	On
*Batch > Detail > End > Action > Feed	-	0 to 50 mm	0 mm
*Batch > Detail > End > Action > Auto inc.	-	On/Off	On
*Batch > Detail > End > Action > POC output	Pen Model	On/Off	Off
*Batch > Detail > End > Action > POC speed	Pen Model	C.Speed/450 mm h	C.Speed
*Batch > Detail > Start2 ... Same as Start			
*Batch > Detail > End2 ... Same as End			
*Batch > MSG format > Message No.	-	1/2/3/4/5	1

Setup Item	Pen/Dot	Selectable Range or Selections	Default Value
*Batch > MSG format > Message No. > (MSG format)	-	35 characters or less	H:M L16

Setup Items in Basic Setting Mode and Their Default Values

Setup Item	Pen/Dot	Selectable Range or Selections	Default Value
Alarm > Diagnosis	-	On/Off	Off
Alarm > Reflash	-	On/Off	Off
Alarm > AND	-	None/I01/I01-I02/I01-I03/I01-I04/I01-I05/I01-I06	None
Alarm > Act	-	Energize/De_energize	Energize
Alarm > Behavior	-	Nonhold/Hold	Nonhold
Alarm > Indicator	-	Nonhold/Hold	Nonhold
Alarm > Increase	-	01 to 15	01
Alarm > Decrease	-	01 to 15	01
Alarm > Hysteresis	-	Off/0.1% to 1.0%	0.5%
Alarm > M_Hysteresis	-	Off/0.1% to 1.0%	Off
A/D > Integrate	Dot Model	Auto/50Hz/60Hz/100ms	Auto
	Pen Model	Auto/50Hz/60Hz	Auto
Burnout > CH	-	01 to 06	01
Burnout > Burnout	-	Off/Up/Down	Off
RJC > CH	-	01 to 06	01
RJC > RJC	-	Internal/External	Internal
RJC > RJC > Volt	-	-20000 to 20000 μ V	0 μ V
Color > Channel	Dot Model	01 to 06	01
Color > Color	Dot Model	Purple/Red/Green/Blue/Brown/Black	01: Purple, 02: Red, 03: Green, 04: Blue, 05: Brown, 06: Black
POC > POC	Pen Model	On/Off	Off
Print > CH/Tag	-	CH/Tag	CH
Print > Channel	Dot Model	On/Off	On
Print > Alarm	-	On1/On2/Off	On1
Print > Record On	-	On/Off	Off
Print > Chart speed	-	On/Off	On
Print > Scale	-	On/Off	On
Print > Pen color	Pen Model	On/Off	On
Print1 > Periodic	-	Auto/Manual	Auto
Print1 > Ref. Time	-	Hour 0 to 23 (1 hour steps)	00:00
Print1 > Interval	-	10min/15min/20min/30min/1h/2h/3h/4h/6h/8h/12h/24h	1h
Print1 > Mode	-	Inst/Report/Off	Inst
Print2 > CH	-	01 to 06	01
Print2 > Mode	-	AVE/MIX/SUM/MIN/MAX/INST	AVE
Print2 > SUM scale	-	Off, /s, /min, /h, /day	Off
Bar graph > CH	-	01 to 06	01
Bar graph > Graph	-	Normal/Center	Normal
Keylock > Keylock	-	Not/Use	Not
Keylock > Password	-	Numbers and spaces within 4 digits	Blank
Keylock > RCD	-	Free/Lock	Free
Keylock > Feed	-	Free/Lock	Free
Keylock > Menu	-	Free/Lock	Free
Keylock > Disp Menu	-	Free/Lock	Free
Keylock > Alarm ACK	-	Free/Lock	Free
Keylock > Math	-	Free/Lock	Free
Keylock > Print out	-	Free/Lock	Free
Keylock > Message	-	Free/Lock	Free
Keylock > Buffer clear	-	Free/Lock	Free
Keylock > Periodic	-	Free/Lock	Free
Keylock > Pen exchange	Pen Model	Free/Lock	Free
Keylock > R. exchange	Dot Model	Free/Lock	Free
Keylock > Data save	-	Free/Lock	Free
Keylock > Data replay	Dot Model	Free/Lock	Free
Keylock > SD eject	-	Free/Lock	Free
Moving_AVE > Moving_AVE	Dot Model	Not/Use	Not

Setup Items and Default Values

Setup Item	Pen/Dot	Selectable Range or Selections	Default Value
Filter > Filter	Pen Model	Not/Use	Not
Partial > Partial	-	Not/Use	Not
Language > Lang	-	English/Japanese/German/French	English
Date format > Type	-	Y/M/D M/D/Y D/M/Y D.M.Y M.D.Y	M.D.Y
Temperature > Temp	-	°C/°F	°C
Personalize > Add function > Bias	-	Not/Use	Not
Personalize > Add function > SQRT low-cut	-	Not/Use	Use
Personalize > Add function > 1-5V low-cut	-	Not/Use	Not
Personalize > Add function > Alarm delay	-	Not/Use	Not
Personalize > Add function > Calibration	-	Not/Use	Use
Personalize > Time print > Alarm	-	HH:MM, HH:MM:SS, M/D H:M, M/D H:M:S, YMD H:M:S	HH:MM
Personalize > Time print > Message	-	HH:MM, HH:MM:SS, M/D H:M, M/D H:M:S, YMD H:M:S, None	HH:MM
Personalize > Time print > RCD On	-	HH:MM, HH:MM:SS, M/D H:M, M/D H:M:S, YMD H:M:S	HH:MM
Personalize > Time print > C.Speed	-	HH:MM, HH:MM:SS, M/D H:M, M/D H:M:S, YMD H:M:S	HH:MM
Setting initialization			
Initialize > Mode	-	Setup+Set/Set	Setup+Set
Initialize > Mode > Are you sure?	-	No/Yes	No
Remote (/R1 option)			
Remote > Remote No.	-	1/2/3/4/5	1
Remote > Remote No. > No.	-	Record On Off /Chart speed/Time adjust/ Math start stop (/M1)/Math reset (/M1)/ Manual print/Alarm ACK/Message1/Message2/ Message3/Message4/Message5/Priority R_ RCD (/BT1)/BatchCMT switch (/BT1)/Data save On/Off (/EM1)/None (/M1, /BT1, /EM1: option)	Record On/Off
Math (/M1 option)			
Math > Timer (TLOG) > Timer No.	-	1/2	1
Math > Timer (TLOG) > Mode	-	Off/Relative/Absolute	Absolute
Math > Timer (TLOG) > Interval (Relative)	-	10 min to 24 h (1 min steps)	01:00
Math > Timer (TLOG) > Interval (Absolute)	-	10min/12min/15min/20min/30min/1h/2h/3h/4h/ 6h/8h/12h/24h	1h
Math > Timer (TLOG) > Ref. Time	-	Hour 0 to 23 (1 hour steps)	00:00
Math > Timer (TLOG) > Reset	-	On/Off	On
Math > Timer (TLOG) > Print	-	On/Off	On
Math > Color > Channel	Dot Model	0A/0B/0C/0D/0E/0F/0G/0J/0K/0M/0N/0P	0A
Math > Color > Color	Dot Model	Purple/Red/Green/Blue/Brown/Black	Purple: 0A/0G Red: 0B/0J Green: 0C/0K Blue: 0D/0M Brown: 0E/0N Black: 0F/0P
Math > Output pen > Pen←CH	Pen Model	Pen: 1 to 4, Channel: 01 to 04/0A to 0J	1pen: 01, 2pen: 02, 3pen: 03, 4pen: 04
Math > Print2 > CH	-	0A/0B/0C/0D/0E/0F/0G/0J/0K/0M/0N/0P	0A
Math > Print2 > Mode	-	AVE/MIX/SUM/MIN/MAX/INST	AVE
Math > Print2 > SUM scale	-	Off, /s, /min, /h, /day	Off
Math > Bar graph > CH	-	0A/0B/0C/0D/0E/0F/0G/0J/0K/0M/0N/0P	0A
Math > Bar graph > Graph	-	Normal/Center	Normal
Math > Error data > Error	-	+Over/-Over	+Over
Math > Error data > Over	-	Skip/Limit	Skip
RS-422/485 (/C3 option)			
RS-422/485 > Address	-	1 to 32	1
RS-422/485 > Baud rate	-	1200/2400/4800/9600/19200/38400	9600
RS-422/485 > Data length	-	7/8	8
RS-422/485 > parity	-	Odd/Even/None	Even
RS-422/485 > Protocol	-	NORMAL/MODBUS	NORMAL
Ethernet (/C7 option)			
Ethernet > Host > Host	-	64 characters or less	Blank

Setup Items and Default Values

Setup Item	Pen/Dot	Selectable Range or Selections	Default Value
Ethernet > Host > Domain	-	64 characters or less	Blank
Ethernet > Local IP > A	-	IP address	0.0.0.0
Ethernet > Local IP > M	-	IP address (Subnet mask)	0.0.0.0
Ethernet > Local IP > G	-	IP address (Default gateway)	0.0.0.0
Ethernet > DNS > DNS	-	On/Off	Off
Ethernet > DNS > P	-	IP address (Primary DNS sever)	0.0.0.0
Ethernet > DNS > S	-	IP address (Secondary DNS sever)	0.0.0.0
Ethernet > DNS > Suffix_P	-	Primary domain suffix	Blank
Ethernet > DNS > Suffix_S	-	Secondary domain suffix	Blank
Ethernet > Login > Login	-	Use/Not	Not
Ethernet > LoginSet > Level	-	Admin/User1 to User6	Admin
Ethernet > LoginSet > Register	-	On/Off	Admin and User1 are On
Ethernet > LoginSet > User	-	16 characters or less	Admin: admin User1 to 6: user1 to user6
Ethernet > LoginSet > Password	-	4 characters or less	Administrator: 0 User1 to 6: 1 to 6
Ethernet > Timeout > Timeout	-	On/Off	Off
Ethernet > Timeout > Duration	-	1 to 120 min	1 min
Ethernet > K. Alive > Keep alive	-	On/Off	On
Calibration (/CC1 option)			
Calibration > Channel	-	01 to 06	01
Calibration > Mode	-	Revise Value, Absolute Value	Revise Value
Calibration > Point	-	2 to 16	2
Cust. menu > Cust. menu	-	Not/Use	Not
Cust. menu > Password	-	Numbers and spaces within 4 digits	Blank
Cust. menu > P_Adj	-	On/Off	Off
Select menu > Set mode > Range	-	On/Off	On
Select menu > Set mode > Bias	-	On/Off	On
Select menu > Set mode > Alarm	-	On/Off	On
Select menu > Set mode > Unit	-	On/Off	On
Select menu > Set mode > Chart speed	-	On/Off	On
Select menu > Set mode > Aux	-	On/Off	On
Select menu > Set mode > Calibration	-	On/Off	On
Select menu > Set mode > Math	-	On/Off	On
Select menu > Set mode > Batch name	-	On/Off	On
Select menu > Set mode > Batch detail	-	On/Off	On
Select menu > Function > Manual print	-	On/Off	On
Select menu > Function > Setup list	-	On/Off	On
Select menu > Function > Message	-	On/Off	On
Select menu > Function > Buffer clear	-	On/Off	On
Select menu > Function > Periodic	-	On/Off	On
Select menu > Function > Data save	-	On/Off	On
Select menu > Function > Data replay	Dot Model	On/Off	On
Select menu > Function > SD eject	-	On/Off	On
Batch (/BT1 option)			
Batch > Batch	-	Not/Use	Not
Batch > Lot No.	-	4/6/Not	4
Batch > Dual comment	-	Not/Use	Not
Batch > MSG format	-	Not/Use	Not
SD card (/EM1 option)			
Load param > File	-	Search text	-
Load param > Mode	-	Setup+Set/Setup	Setup+Set
Format > Label	-	Up to 11 characters	-
Format > Execute	-	Execute	Execute
Adjustment			
P_Adj > P_Adj	Dot Model	Hysteresis/Zero/Full	Hysteresis
	Pen Model	Zero/Full	Zero
P_Adj > Pen No.	Pen Model	1/2/3/4	1
Store			
End > End	-	Store/Abort	Store

Recommended Replacement Periods for Worn Parts

To preserve the reliability of the recorder and to use the recorder in good condition for an extended time, it is recommended that periodic replacements be made on parts. The replacement parts may change to accommodate preventive maintenance over extended time. Be sure to check with your nearest YOKOGAWA dealer.

The table below shows the recommended replacement period for expendable parts. The replacement period shown here applies when the recorder is used under standard operating conditions. For the actual replacement period, consider the actual conditions of use.

Replacement of parts other than the chart paper, pen, ribbon cassette, and internal light LED will be carried out by a YOKOGAWA engineer or an engineer certified by YOKOGAWA. Contact your nearest YOKOGAWA dealer when such replacement is necessary.

Note

The replacement period of the display and the internal light LED is the half life of the brightness. The deterioration of brightness varies depending on the condition of use, and its determination is subjective. Consider these facts for determining the actual replacement period.

Pen Model

Item	Replacement Period	Part Name	Part No.	Note	Quantity Used
Z-fold chart paper	33 days	CHART	B9565AW	When used at 20 mm/h	1
Felt pen	2 km	PEN ASSY	B9902AM B9902AN B9902AP B9902AQ	Red Green Blue Violet } At a pen speed of 10 cm/s	1 each
Plotter pen	60,000 characters**	PEN ASSY	B9902AR	When printing continuously	1
Display	5 years*	DISPLAY ASSY	B8800CA		1
Chart paper feed motor	5 years	MOTOR ASSY	B8801BP		1
Plotter carriage	5 years	CARRIAGE ASSY	B8801BJ		1
Plotter motor	5 years	MOTOR ASSY	B8801BR	For the X-axis	1
Lever bearing	5 years	BEARING	B9900RP	For the plotter	1
Pen servo	5 years	SERVO ASSY	B8800GG	Shared by all pens (excludes the pen arm ASSY)	1 to 4
Internal light LED	2 years*	LED ASSY	B8800CR		1

* The half life of the brightness at the factory default brightness setting.

** Smearing may occur around the ridge-folding part of the chart paper.

Dot Model

Item	Replacement Period	Part Name	Part No.	Note	Quantity Used
Z-fold chart paper	33 days	CHART	B9565AW	When used at 20 mm/h	1
Ribbon cassette	3 months	RIBBON CASSETTE	B9901AX		1
Display	5 years*	DISPLAY ASSY	B8800CA		1
Chart paper feed motor	5 years	MOTOR ASSY	B8801BP		1
Lever	3 years	LEVER ASSY	B9901EK	For the carriage	1
Pulley	3 years	PULLY	B9963CJ	For the carriage	2
Carriage motor	5 years	MOTOR ASSY	B9963CF		1
Carriage	5 years	CARRIAGE ASSY	B9963CL		1
Ribbon shift motor	5 years	MOTOR ASSY	B8801BR		1
Ribbon shift gear	5 years	GEAR	B8801BX B8801BW		1 each
Ribbon feed motor	5 years	MOTOR ASSY	B8801BP		1
Ribbon feed gear	5 years	RIBBON HOLDER ASSY	B8801AG	Included RIBBON FEED MOTOR, RIBBON HOLDER	1
Internal light LED	2 years*	LED ASSY	B8800CR		1

* The half life of the brightness at the factory default brightness setting.