

## Housings and miscellaneous parts

Standard and special valve housings, orifice disks, orifice sizing charts, pilot pistons, adapters, adjustment kits and seal kits

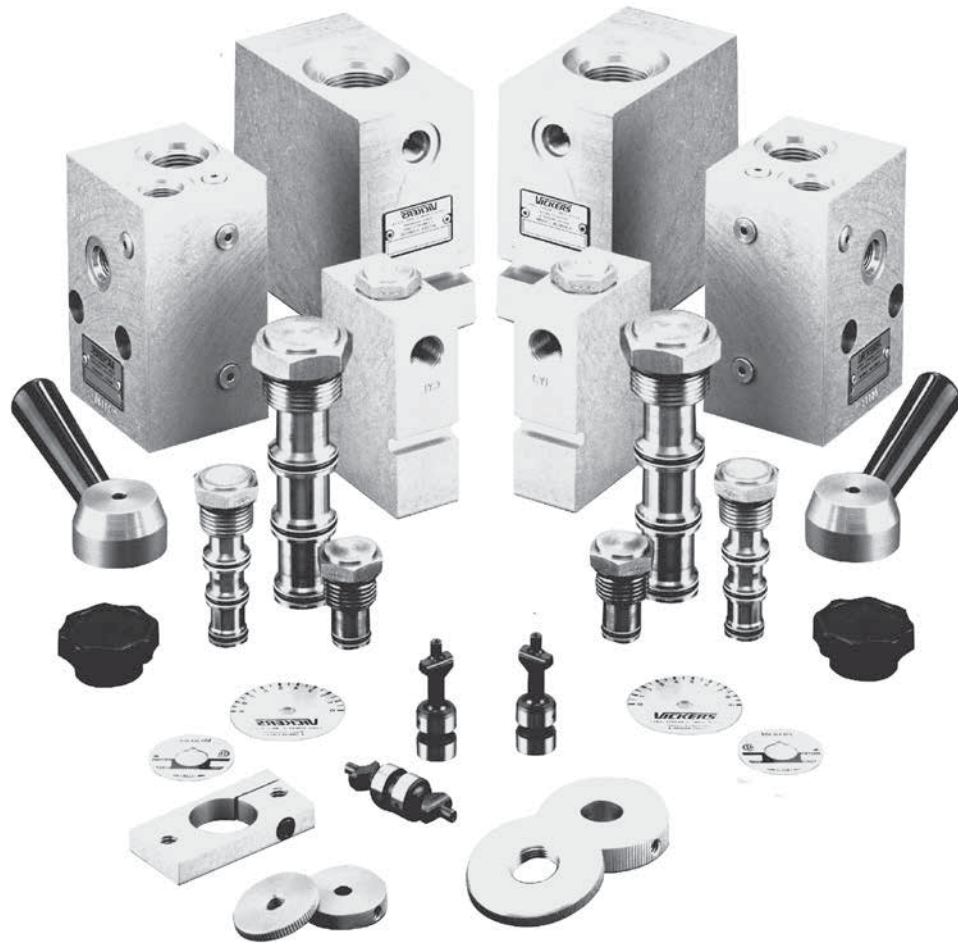



# Housing & miscellaneous parts

C-**-2.....	J-4
C-**-3/3S.....	J-7
C-**-3.....	J-9
C-**-3S .....	J-10
C-16-3S .....	J-11
C-**-4.....	J-12
C-**-5S .....	J-15
PORT DIMENSIONS.....	J-16
CAVITY PLUGS .....	J-17
ECF - PRESSURE FILTERS.....	J-19
ORIFICE DISCS .....	J-21
ORIFICE DISC - SIZING GUIDE (MM) .....	J-22
ORIFICE DISC - SIZING GUIDE (INCHES) .....	J-23
PILOT PISTONS .....	J-24
SENSING CHECK/PANEL MOUNT ADAPTER .....	J-25
MISCELLANEOUS PARTS .....	J-26
ADJUSTMENT KITS .....	J-27
1HP7 - HAND PUMP .....	J-29
1HP10 - HAND PUMP .....	J-31
1T162W6S - PRESSURE INTENSIFIER.....	J-33

# C-\*\*-2

## Aluminum housings (light duty)

Housing	Ports 1 & 2	Part number	Code
C-10-2	3/8" BSPP SAE 6	02-175462 566151	(A)3B (A)6T
C-16-2	3/4" BSPP SAE 12	02-175463 566149	(A)6B (A)12T
C-20-2	1" BSPP SAE 16	02-175464 566409	(A)8B (A)16T

**Notes:** BSPP porting is designated by "B" in the model code SAE porting is designated by "T" in the model code.

Light duty aluminum housings are intended for applications up to 210 bar (3000 psi) with light to moderate duty cycles.

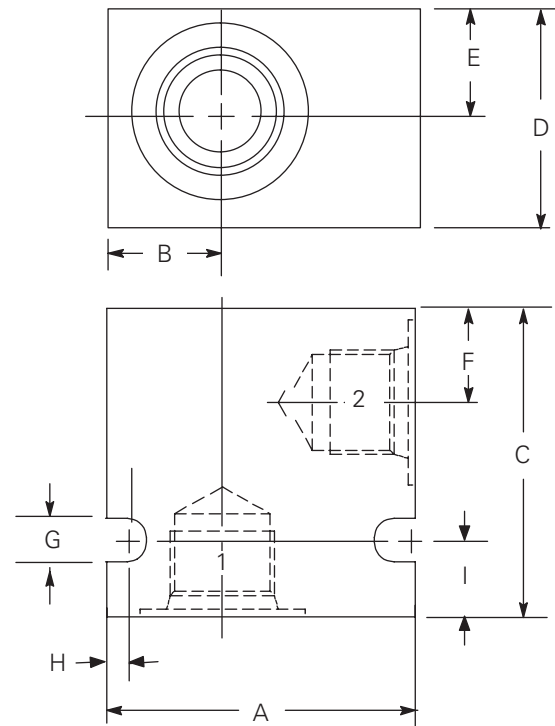

Dimensions	A	B	C	D	E	F	G	H	I	Mass
mm (inch)										kg (lb)
C-10-2	50,8 (2.00)	19,0 (0.75)	50,8 (2.00)	31,7 (1.25)	15,9 (0.62)	19,0 (0.75)	7,1 (0.28)	3,1 (0.12)	12,7 (0.50)	0,1 (0.35)
C-16-2	76,2 (3.00)	28,5 (1.12)	76,2 (3.00)	47,6 (1.87)	23,8 (0.94)	25,4 (1.00)	8,6 (0.34)	4,0 (0.16)	19,0 (0.75)	0,5 (1.21)
C-20-2	88,9 (3.50)	34,3 (1.35)	88,9 (3.50)	68,5 (2.70)	34,3 (1.35)	36,8 (1.45)	8,6 (0.34)	4,0 (0.16)	21,6 (0.85)	0,8 (1.90)

Where measurements are critical request certified drawings. We reserve the right to change specifications without notice.

Housing	Ports 1 & 2	Part number	Code
C-8-2	1/4" BSPP	02-160727	(A)2G
	3/8" BSPP	02-160728	(A)3G
	SAE 4	02-160730	(A)4H
	SAE 6	02-160731	(A)6H
	SAE 8	02-160732	(A)8H
C-10-2	1/4" BSPP	876702	(A)2G
	3/8" BSPP	876703	(A)3G
	SAE 6	876700	(A)6H
	SAE 8	876701	(A)8H
C-12-2	1/2" BSPP	02-161118	(A)4G
	3/4" BSPP	02-161117	(A)6G
	SAE 10	02-160640	(A)10H
	SAE 12	02-160644	(A)12H

Housing	Ports 1 & 2	Part number	Code
C-12-2U	1/2" BSPP	02-161116	(A)4G
	3/4" BSPP	02-161115	(A)6G
	SAE 10	02-160641	(A)10H
	SAE 12	02-160645	(A)12H
C-16-2	1/2" BSPP	876716	(A)4G
	3/4" BSPP	876718	(A)6G
	SAE 10	876717	(A)10H
	SAE 12	566113	(A)12H
C-20-2	3/4" BSPP	876732	(A)6G
	1" BSPP	876734	(A)8G
	SAE 12	876733	(A)12H
	SAE 16	876735	(A)16H

**Notes:** BSPP porting is designated by "G" in the model code SAE porting is designated by either "H" or "T" in the model code.

Fatigue rated aluminum housings are intended for applications up to 210 bar (3000 psi) with harsh duty cycles. These housings have been fatigue rated to NFPA standards to one million cycles.

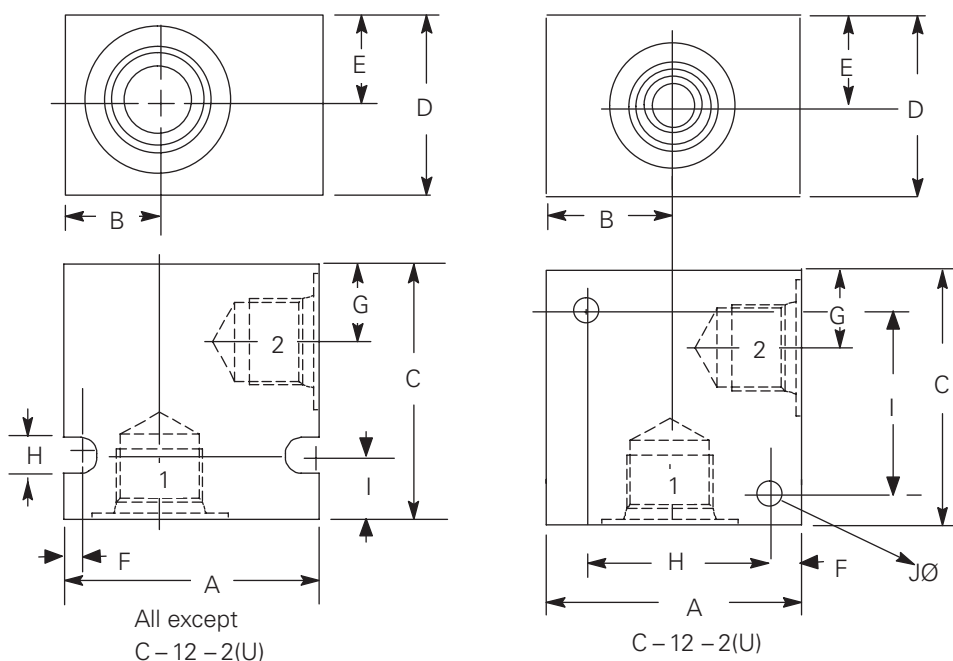

Dimensions	A	B	C	D	E	F	G	H	I	J	Mass
mm (inch)											kg (lb)
C-8-2	50,8 (2.00)	19,0 (0.75)	50,8 (2.00)	38,1 (1.50)	19,0 (0.75)	3,4 (0.13)	15,5 (0.61)	7,1 (0.28)	12,7 (0.50)	7,1 (0.28)	0,2 (0.46)
C-10-2	63,5 (2.50)	25,4 (1.00)	63,5 (2.50)	50,8 (2.00)	25,4 (1.00)	9,5 (0.37)	19,1 (0.75)	7,1 (0.28)	19,1 (0.75)	7,1 (0.28)	0,4 (1.00)
C-12-2(U)	88,9 (3.50)	44,5 (1.75)	88,9 (3.50)	50,8 (2.00)	25,4 (1.00)	12,7 (0.50)	28,7 (1.13)	63,5 (2.50)	63,5 (2.50)	10,3 (0.40)	0,8 (1.96)
C-16-2	88,9 (3.50)	34,9 (1.37)	88,9 (3.50)	63,5 (2.50)	31,8 (1.25)	10,3 (0.40)	28,4 (1.11)	8,7 (0.34)	25,4 (1.00)	10,3 (0.40)	1,2 (2.75)
C-20-2	101,6 (4.00)	38,1 (1.50)	101,6 (4.00)	82,5 (3.25)	41,3 (1.62)	10,3 (0.40)	36,0 (1.41)	8,7 (0.34)	25,4 (1.00)	10,3 (0.40)	1,8 (4.00)

Where measurements are critical request certified drawings. We reserve the right to change specifications without notice.

# C-\*\*-2

## Steel housings (NFPA fatigue rated)

Housing	Ports 1 & 2	Part number	Code
C-8-2	1/4" BSPP	02-160733	(S)2G
	3/8" BSPP	02-160734	(S)3G
	SAE 4	02-160736	(S)4T
	SAE 6	02-160737	(S)6T
	SAE 8	02-160738	(S)8T
C-10-2	1/4" BSPP	02-175102	(S)2G
	3/8" BSPP	02-175103	(S)3G
	SAE 6	02-175100	(S)6T
	SAE 8	02-175101	(S)8T
C-12-2	1/2" BSPP	02-172062	(S)4G
	3/4" BSPP	02-169665	(S)6G
	SAE 10	02-169744	(S)10T
	SAE 12	02-169782	(S)12T

Housing	Ports 1 & 2	Part Number	Code
C-12-2U	1/2" BSPP	02-172512	(S)4G
	3/4" BSPP	02-162922	(S)6G
	SAE 10	02-169817	(S)10T
	SAE 12	02-169790	(S)12T
C-16-2	1/2" BSPP	02-175106	(S)4G
	3/4" BSPP	02-175107	(S)6G
	SAE 10	02-175104	(S)10T
	SAE 12	02-175105	(S)12T
C-20-2	3/4" BSPP	02-175110	(S)6G
	1" BSPP	02-175111	(S)8G
	SAE 12	02-175108	(S)12T
	SAE 16	02-175109	(S)16T

**Notes:** BSPP porting is designated by "G" in the model code SAE porting is designated by "T" in the model code.

Fatigue rated steel housings are intended for applications up to 350 bar (5000 psi) with harsh duty cycles. These housings have been fatigue rated to NFPA standards to one million cycles.

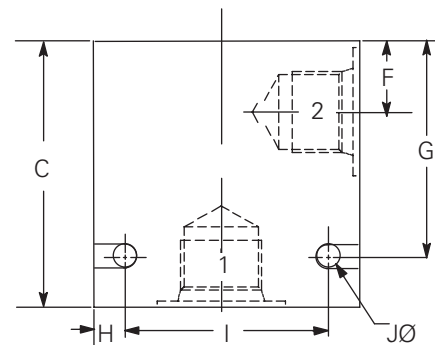
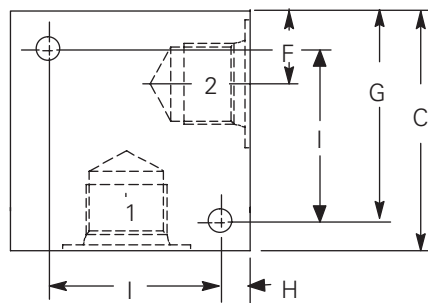
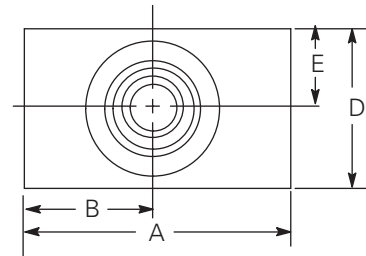
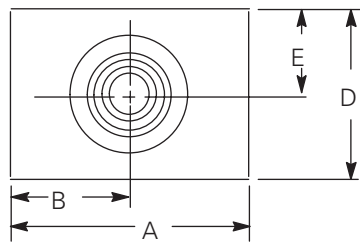

C -12 - 2(U)

Dimensions	A	B	C	D	E	F	G	H	I	J	Mass
mm (inch)											kg (lb)
C-8-2*	50,8 (2.00)	19,0 (0.75)	50,8 (2.00)	38,1 (1.50)	19,1 (0.75)	15,5 (0.61)	38,1 (1.50)	3,3 (0.13)	44,0 (1.73)	7,1 (0.28)	0,5 (1.19)
C-10-2	63,5 (2.50)	25,4 (1.00)	63,5 (2.50)	44,4 (1.75)	22,2 (0.87)	19,0 (0.75)	50,8 (2.00)	9,5 (0.37)	44,4 (1.75)	7,1 (0.28)	0,3 (0.83)
C-12-2(U)	88,9 (3.50)	44,5 (1.75)	88,9 (3.50)	50,8 (2.00)	25,4 (1.00)	28,7 (1.13)	76,2 (3.00)	12,7 (0.50)	63,5 (2.50)	10,3 (0.40)	1,9 (4.28)
C-16-2	88,9 (3.50)	38,1 (1.75)	76,2 (3.00)	50,8 (2.00)	25,4 (1.00)	25,4 (1.00)	63,5 (2.50)	12,7 (0.50)	63,5 (2.50)	10,3 (0.40)	2,2 (5.00)
C-20-2	101,6 (4.00)	40,6 (1.50)	88,9 (3.50)	63,5 (2.50)	31,7 (1.25)	31,7 (1.25)	76,2 (3.00)	12,7 (0.50)	76,2 (3.00)	10,3 (0.40)	3,6 (7.96)

\* 8 series housing utilize a slot instead of a mounting hole.

Where measurements are critical request certified drawings. We reserve the right to change specifications without notice.

Housing	Ports 1, 2 & 3	Part number	Code
C-10-3	3/8" BSPP SAE 6	02-173358 566162	(A)3B (A)6T
C-10-3S	3/8" BSPP SAE 6	02-175470 566413	(A)3B (A)6T
C-16-3	3/4" BSPP SAE 12	02-175465 566152	(A)6B (A)12T
C-16-3S	3/4" BSPP SAE 12	02-175471 566414	(A)6B (A)12T
C-20-3	1" BSPP SAE 12	02-175466 566408	(A)8B (A)12T
C-20-3S	1" BSPP SAE 16	02-175472 566415	(A)8B (A)16T

**Notes:** BSPP porting is designated by "B" in the model code SAE porting is designated by "T" in the model code.

Light duty aluminum housings are intended for applications up to 210 bar (3000 psi) with light to moderate duty cycles.

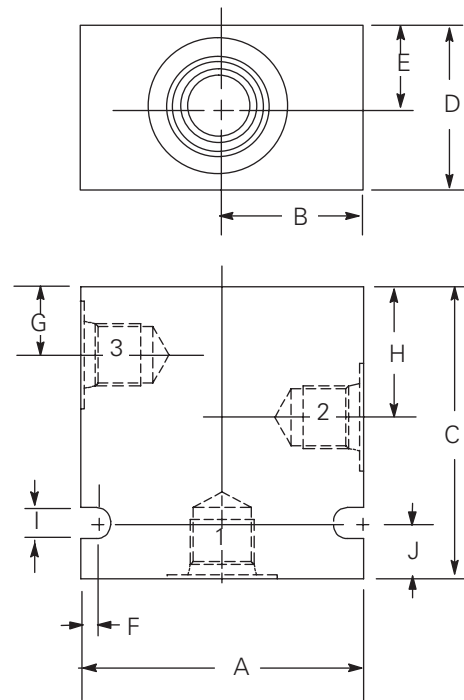

Dimensions	A	B	C	D	E	F	G	H	I	J	Mass
<b>mm (inch)</b>											<b>kg (lb)</b>
C-10-3	63,5 (2.50)	31,7 (1.25)	66,6 (2.62)	31,7 (1.25)	15,8 (0.62)	3,1 (0.12)	19,0 (0.75)	34,9 (1.37)	7,1 (0.28)	12,7 (0.50)	0,3 (0.64)
C-10-3S	63,5 (2.50)	34,9 (1.37)	69,8 (2.75)	38,1 (1.50)	19,1 (0.75)	3,1 (0.12)	12,7 (0.50)	31,7 (1.25)	7,1 (0.28)	12,7 (0.50)	0,2 (0.51)
C-16-3	101,6 (4.00)	50,8 (2.00)	107,9 (4.25)	50,8 (2.00)	25,4 (1.00)	4,0 (0.16)	25,4 (1.00)	53,9 (2.12)	8,6 (0.33)	25,4 (1.00)	1,0 (2.3)
C-16-3S	88,9 (3.50)	47,6 (1.87)	88,9 (3.50)	60,3 (2.37)	30,1 (1.63)	4,0 (0.16)	17,4 (0.68)	38,1 (1.50)	8,7 (0.34)	19,0 (0.75)	0,7 (1.66)
C-20-3	114,3 (4.50)	57,1 (2.25)	139,7 (5.50)	63,5 (2.50)	31,7 (1.25)	4,0 (0.16)	31,7 (1.25)	72,1 (2.84)	10,4 (0.41)	25,4 (1.00)	1,7 (3.92)
C-20-3S	101,6 (4.00)	57,1 (2.25)	107,9 (4.25)	69,8 (2.75)	34,9 (1.37)	4,0 (0.16)	20,6 (0.81)	50,8 (2.00)	8,7 (0.34)	19,0 (0.75)	1,2 (2.62)

Where measurements are critical request certified drawings. We reserve the right to change specifications without notice.

# C-\*\*-3/3S

Aluminum housings  
(NFPA fatigue rated)

Housing	Ports 1, 2 & 3	Part number	Code
C-8-3	1/4" BSPP	02-160739	(A)2G
	3/8" BSPP	02-160740	(A)3G
	SAE 4	02-160741	(A)4H
	SAE 6	02-160742	(A)6H
C-10-3	1/4" BSPP	876705	(A)2G
	3/8" BSPP	876714	(A)3G
	SAE 6	876704	(A)6H
	SAE 8	876711	(A)8H
C-10-3S	1/4" BSPP	876707	(A)2G
	3/8" BSPP***	876710	(A)3G
	SAE 6	876706	(A)6H
	SAE 8**	876712	(A)8H
C-12-3	1/2" BSPP	02-161817	(A)4G
	3/4" BSPP	02-161816	(A)6G
	SAE 10	02-160642	(A)10H
	SAE 12	02-160646	(A)12H
C-12-3S	1/2" BSPP*	02-178270	(A)4G
	3/4" BSPP*	02-178271	(A)6G
	SAE 10**	02-178268	(A)10H
	SAE 12**	02-178269	(A)12H

Housing	Ports 1, 2 & 3	Part number	Code
C-16-3	1/2" BSPP	876720	(A)4G
	3/4" BSPP	876722	(A)6G
	SAE 10	876721	(A)10H
	SAE 12	876723	(A)12H
C-16-3S	1/2" BSPP	02-160676	(A)4G
	3/4" BSPP	876726	(A)6G
	SAE 10	876725	(A)10H
	SAE 12	876727	(A)12H
C-20-3	1/2" BSPP	876737	(A)4G
	3/4" BSPP***	876738	(A)6G
	SAE 10	876757	(A)10H
	SAE 12	876739	(A)12H
C-20-3S	3/4" BSPP	876740	(A)6G
	1" BSPP	876742	(A)8G
	SAE 12	876741	(A)12H
	SAE 16	876743	(A)16H

\* Port 3 = 3/8" BSPP

\*\* Port 3 = SAE 6

\*\*\* Port 3 = 1/4" BSPP

**Notes:** BSPP porting is designated by "G" in the model code SAE porting is designated by either "H" or "T" in the model code.

Fatigue rated aluminum housings are intended for applications up to 210 bar (3000 psi) with harsh duty cycles. These housings have been fatigue rated to NFPA standards to one million cycles.

Only for C-12-3\*  
Two holes Ø10.3(0.04),  
(82,5) 3.250 apart

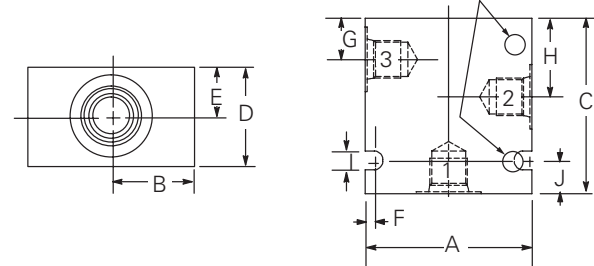

Dimensions	A	B	C	D	E	F	G	H	I	J	Mass
mm (inch)											kg (lb)
C-8-3	63,5 (2.50)	31,8 (1.25)	67,3 (2.65)	38,1 (1.50)	19,1 (0.75)	3,4 (0.13)	15,5 (0.61)	29,8 (1.17)	7,1 (0.28)	13,3 (0.52)	0,4 (0.83)
C-10-3	75,4 (2.97)	38,1 (1.50)	75,4 (2.97)	50,0 (1.97)	24,6 (0.97)	9,5 (0.37)	18,8 (0.74)	34,8 (1.37)	7,1 (0.28)	18,2 (0.72)	0,7 (1.65)
C-10-3S	76,2 (3.00)	38,1 (1.50)	76,2 (3.00)	50,8 (2.00)	25,4 (1.00)	9,5 (0.37)	15,1 (0.59)	31,7 (1.25)	7,1 (0.28)	19,0 (0.75)	0,7 (1.65)
C-12-3	88,9 (3.50)	44,5 (1.75)	107,9 (4.25)	50,8 (2.00)	25,4 (1.00)	76,2 (3.00)	28,7 (1.13)	51,6 (2.03)	10,3 (0.41)	12,7 (0.50)	0,8 (1.80)
C-12-3S	88,9 (3.50)	44,5 (1.75)	101,6 (4.00)	50,8 (2.00)	25,4 (1.00)	76,2 (3.00)	23,0 (0.91)	42,1 (1.66)	10,3 (0.41)	44,5 (1.75)	0,8 (1.80)
C-16-3	114,3 (4.50)	60,3 (2.37)	114,3 (4.50)	63,5 (2.50)	31,8 (1.25)	10,3 (0.41)	28,4 (1.12)	57,0 (2.24)	8,7 (0.34)	25,4 (1.00)	2,0 (4.50)
C-16-3S	114,3 (4.50)	54,0 (2.12)	114,3 (4.50)	63,5 (2.50)	31,7 (1.25)	10,3 (0.40)	20,5 (0.81)	38,1 (1.50)	8,7 (0.34)	25,4 (1.00)	2,0 (4.40)
C-20-3	127,0 (5.00)	63,5 (2.50)	139,7 (5.50)	82,5 (3.25)	41,2 (1.62)	10,3 (0.40)	31,7 (1.25)	72,2 (2.84)	8,7 (0.34)	25,4 (1.00)	3,5 (7.71)
C-20-3S	127,0 (5.00)	63,5 (2.50)	127,0 (5.00)	82,5 (3.25)	41,2 (1.62)	10,3 (0.40)	20,6 (0.81)	50,8 (2.00)	8,7 (0.34)	25,4 (1.00)	3,6 (8.00)

Where measurements are critical request certified drawings. We reserve the right to change specifications without notice.



Housing	Ports 1, 2 & 3	Part number	Code
C-8-3	1/4" BSPP	02-160743	(S)2G
	3/8" BSPP	02-160744	(S)3G
	SAE 4	02-160745	(S)4T
	SAE 6	02-160746	(S)6T
C-10-3	1/4" BSPP	02-175127	(S)2G
	3/8" BSPP	02-175128	(S)3G
	SAE 6	02-175124	(S)6T
	SAE 8	02-175125	(S)8T
C-12-3	1/2" BSPP	02-169815	(S)4G
	3/4" BSPP	02-169814	(S)6G
	SAE 10	02-161070	(S)10T
	SAE 12	02-169816	(S)12T
C-16-3	1/2" BSPP	02-175131	(S)4G
	3/4" BSPP	02-175132	(S)6G
	SAE 10	02-175129	(S)10T
	SAE 12	02-175130	(S)12T
C-20-3	3/4" BSPP	02-175135	(S)6G
	1" BSPP	02-175136	(S)8G
	SAE 12	02-175133	(S)12T
	SAE 16	02-175134	(S)16T

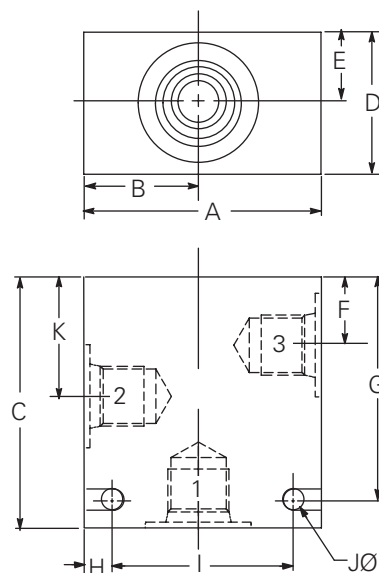

**Notes:** BSPP porting is designated by "G" in the model code SAE porting is designated by "T" in the model code.

Fatigue rated steel housings are intended for applications up to 350 bar (5000 psi) with harsh duty cycles. These housings have been fatigue rated to NFPA standards to one million cycles.

Dimensions	A	B	C	D	E	F	G	H	I	J	K	Mass
mm (inch)												kg (lb)
C-8-3*	63,5 (2.50)	31,8 (1.25)	66,7 (2.63)	38,1 (1.50)	19,1 (0.75)	15,5 (0.61)	54,0 (2.13)	3,3 (0.13)	56,9 (2.24)	7,1 (0.28)	29,8 (1.17)	0,9 (2.15)
C-10-3	76,2 (3.00)	38,1 (1.50)	76,2 (3.00)	44,4 (1.75)	22,4 (0.88)	19,1 (0.75)	63,5 (2.50)	9,7 (0.38)	57,0 (2.24)	7,1 (0.28)	35,1 (1.38)	1,7 (3.75)
C-12-3	88,9 (3.50)	44,4 (1.75)	101,6 (4.00)	50,8 (2.00)	25,4 (1.00)	28,7 (1.13)	88,9 (3.50)	12,7 (0.50)	63,5 (2.50)	10,3 (0.40)	51,5 (2.03)	3,0 (6.75)
C-16-3	101,6 (4.00)	50,8 (2.00)	107,9 (4.25)	50,8 (2.00)	25,4 (1.00)	25,4 (1.00)	88,9 (3.50)	12,7 (0.50)	76,2 (3.00)	10,3 (0.40)	54,0 (2.13)	3,4 (7.70)
C-20-3	114,3 (4.50)	57,1 (2.25)	139,7 (5.50)	63,5 (2.50)	31,8 (1.25)	31,8 (1.25)	114,3 (4.50)	19,0 (0.75)	76,2 (3.00)	11,9 (0.47)	72,2 (2.84)	6,4 (14.30)

\* 8 Series housings utilize a slot instead of mounting holes.

# C-\*\*-3S

## Steel housings (NFPA fatigue rated)

Housing	Ports 1 & 2	Port 3	Part number	Code
C-10-3S	3/8" BSPP	1/4" BSPP	02-163313	(S)3G
	1/2" BSPP	1/4" BSPP	02-163324	(S)4G
	SAE 6	SAE 6	02-171961	(S)6T
	SAE 8	SAE 6	02-163322	(S)8T
	SAE 10	SAE 6	02-163323	(S)10T
C-12-3S	1/2" BSPP	3/8" BSPP	02-160994	(S)4G
	3/4" BSPP	3/8" BSPP	02-160995	(S)6G
	SAE 10	SAE 6	02-160996	(S)10T
	SAE 12	SAE 6	02-160997	(S)12T
C-16-3S	1/2" BSPP	3/8" BSPP	02-175118	(S)4G
	3/4" BSPP	3/8" BSPP	02-175119	(S)6G
	SAE 10	SAE 6	02-175116	(S)10T
	SAE 12	SAE 6	02-175117	(S)12T
C-20-3S	3/4" BSPP	3/8" BSPP	02-175122	(S)6G
	1" BSPP	3/8" BSPP	02-175123	(S)8G
	SAE 12	SAE 6	02-175120	(S)12T
	SAE 16	SAE 6	02-175121	(S)16T

**Notes:** BSPP porting is designated by "G" in the model code SAE porting is designated by "T" in the model code.

Fatigue rated steel housings are intended for applications up to 350 bar (5000 psi) with harsh duty cycles. These housings have been fatigue rated to NFPA standards to one million cycles.

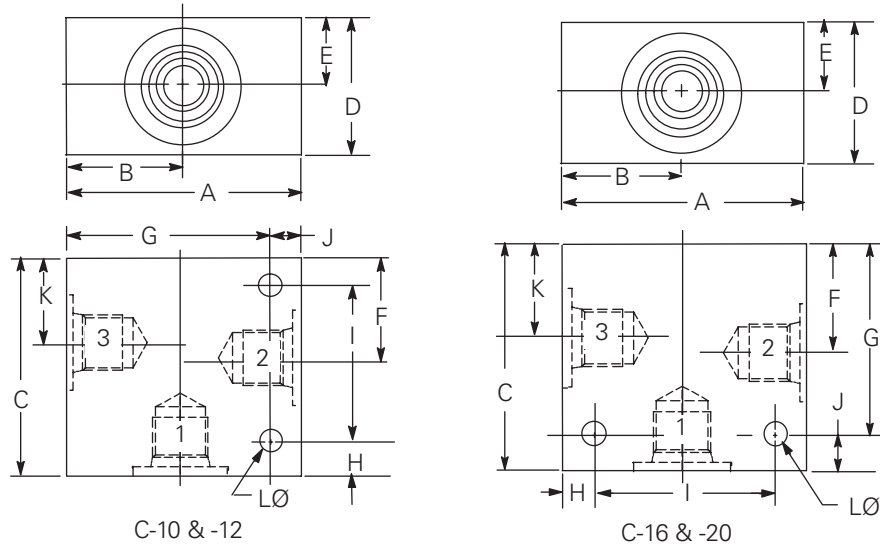

Dimensions	A	B	C	D	E	F	G	H	I	J	K	Lø	Mass
mm (inch)													kg (lb)
C-10-3S	63,5 (2.50)	31,8 (1.25)	76,2 (3.00)	41,3 (1.63)	20,7 (0.82)	36,6 (1.44)	53,8 (2.12)	11,2 (0.44)	53,8 (2.12)	9,7 (0.38)	19,8 (0.78)	8,7 (0.34)	1,08 (2.40)
C-12-3S	88,9 (3.50)	44,5 (1.75)	101,6 (4.00)	50,8 (2.00)	25,4 (1.00)	41,9 (1.65)	76,2 (3.00)	31,7 (1.25)	57,1 (2.25)	12,7 (0.50)	23,1 (0.91)	10,3 (0.40)	2,4 (5.40)
C-16-3S	88,9 (3.50)	41,2 (1.62)	88,9 (3.50)	50,8 (2.00)	25,4 (1.00)	38,1 (1.50)	69,8 (2.75)	12,7 (0.50)	63,5 (2.50)	19,0 (0.75)	17,4 (0.68)	10,3 (0.40)	2,6 (5.90)
C-20-3S	101,6 (4.00)	44,4 (1.75)	114,3 (4.50)	63,5 (2.50)	31,7 (1.25)	50,8 (2.00)	88,9 (3.50)	12,7 (0.50)	76,2 (3.00)	25,4 (1.00)	20,6 (0.81)	10,3 (0.40)	4,6 (10.24)

Where measurements are critical request certified drawings. We reserve the right to change specifications without notice.

**For use with EPV16-A or B only.**  
**Housing Number**

Code	Port Size	Aluminum EPV16-A	EPV16-B	Steel EPV16-A	EPV16-B
4G	1/2" BSPP	02-185448	02-166607	02-180050	02-165500
6G	3/4" BSPP	02-185449	02-161582	02-180051	02-164931
10H	SAE 10	02-185446	02-170238	-	-
12H	SAE 12	02-185447	02-166609	-	-
10T	SAE 10	-	-	02-180048	02-161983
12T	SAE 12	-	-	02-180049	02-161982
5C	CETOP5 (NFPA D05) interface (Requires steel housing)				

Model	A	B	C	D	E	F	G	ØH	J	Mass kg (lb)	
										Alum	Steel
Modified C-16-3S	76,2	30,2	79,2	100,8	38,1	12,7	21,4	8,7	60,4	2,0	6,0
body	(3.00)	(1.19)	(3.12)	(3.97)	(1.50)	(0.50)	(0.84)	(0.34)	(2.38)	(4.50)	(13.5)

Modified housing for use with EPV16-A.

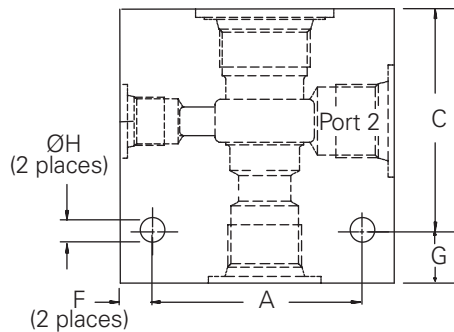

Modified housing for use with EPV16-B.

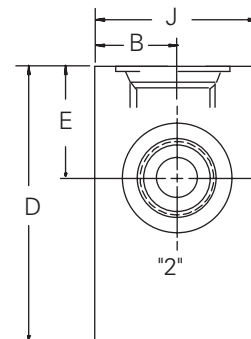
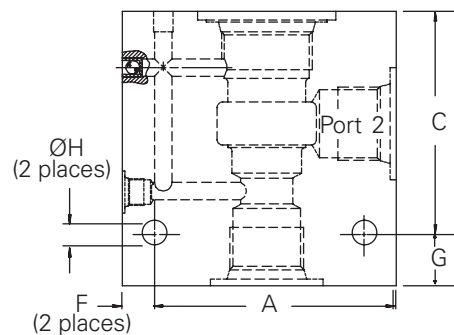

Where measurements are critical request certified drawings. We reserve the right to change specifications without notice.

# C-\*\*-4

## Aluminum housings (light duty)

Housing	Ports 1, 2, 3 & 4	Part number	Code
C-10-4	3/8" BSPP SAE 6	02-179705 566161	(A)3B (A)6T
C-12-4	SAE10	6030517-001	(A)10T
C-16-4	3/4" BSPP SAE 12	02-175468 566411	(A)6B (A)12T
C-20-4	1" BSPP SAE 16	02-175469 566412	(A)8B (A)16T

### Housing (FDC\*\*-\*\*only)

C-10-4	3/8" BSPP SAE 6	02-175467 566234	(A)3B (A)6T
C-16-4	3/4" BSPP SAE 12	02-175468 566200	(A)6B (A)12T

**Notes:** BSPP porting is designated by "B" in the model code SAE porting is designated by "T" in the model code.

Light duty aluminum housings are intended for applications up to 210 bar (3000 psi) with light to moderate duty cycles.

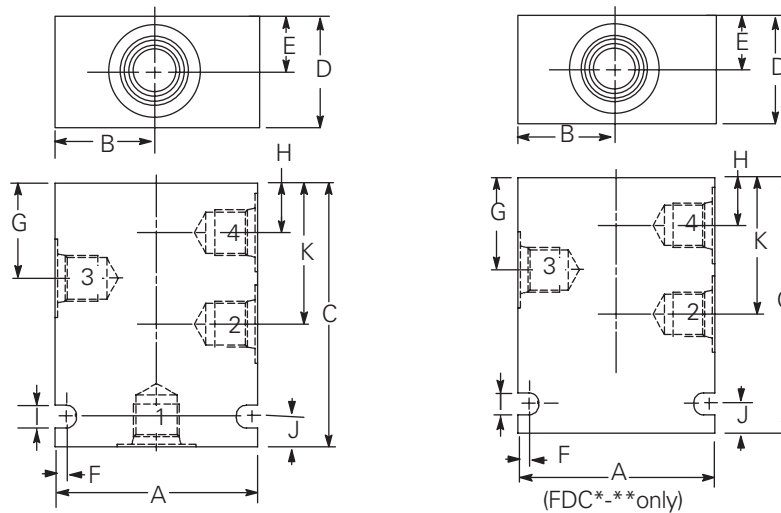

Dimensions	A	B	C	D	E	F	G	H	I	J	K	Mass
mm (inch)												
C-10-4	63,5 (2.50)	31,7 (1.25)	82,5 (3.25)	31,7 (1.25)	15,8 (0.62)	3,1 (0.12)	34,9 (1.37)	19,0 (0.75)	7,1 (0.28)	9,5 (0.37)	50,8 (2.00)	0,3 (0.72)
C-16-4	106,6 (4.00)	50,8 (2.00)	133,3 (5.25)	50,8 (2.00)	25,4 (1.00)	3,8 (0.15)	53,9 (2.12)	25,4 (1.00)	8,7 (0.34)	22,2 (0.87)	82,5 (3.25)	1,4 (3.24)
C-20-4	114,3 (4.50)	57,1 (2.25)	117,8 (7.00)	63,5 (2.50)	31,7 (1.25)	4,0 (0.16)	72,1 (2.84)	31,7 (1.25)	10,4 (0.41)	25,4 (1.00)	113,5 (4.47)	2,6 (5.76)

**Note:** For C-10-4 housings for VCB valves see page J-25.

Where measurements are critical request certified drawings. We reserve the right to change specifications without notice.

Housing	Ports 1, 2, 3 & 4	Part number	Code
C-8-4	1/4" BSPP	02-160747	(A)2G
	3/8" BSPP	02-160748	(A)3G
	SAE 4	02-160749	(A)4T
	SAE 6	02-160750	(A)6T
C-10-4	1/4" BSPP	876709	(A)2G
	3/8" BSPP	876715	(A)3G
	SAE 6	876708	(A)6H
C-12-4	3/4" BSPP	5986432-001	(A)6G
	SAE 10	5986434-001	(A)10T
	SAE 12	5986436-001	(A)12T
C-16-4	1/2" BSPP	876728	(A)4G
	3/4" BSPP	876730	(A)6G
	SAE 10	876279	(A)10H
C-20-4	SAE 12	876731	(A)12H
	3/4" BSPP	876744	(A)6G
	1" BSPP	876746	(A)8G
	SAE 12	876745	(A)12H
	SAE 16	876747	(A)16H

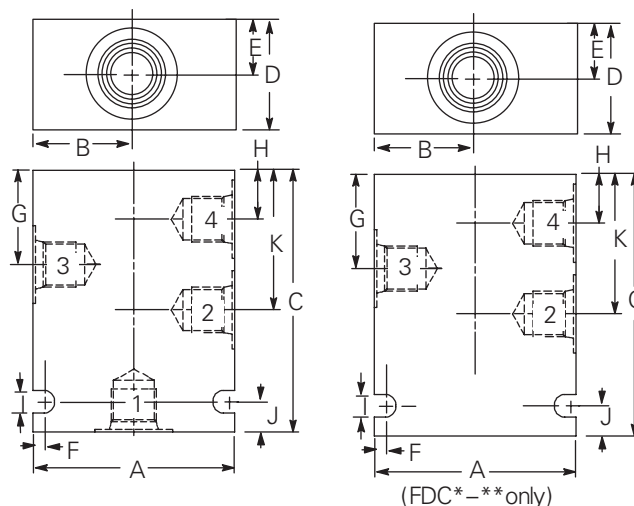
**Housing (FDC\*-\*\*-4 only)**

C-10-4	1/4" BSPP	02-185804	(A)2G
	3/8" BSPP	02-185805	(A)3G
	SAE 6	02-185802	(A)6H
	SAE 8	02-185803	(A)8H

**Notes:** BSPP porting is designated by "G" in the model code SAE porting is designated by either "H" in the model code.

Fatigue rated aluminum housings are intended for applications up to 210 bar (3000 psi) with harsh duty cycles. These housings have been fatigue rated to NFPA standards to one million cycles.

For C-10-4 and C-12-4 housings for VCB valves see pages J-25 & J-27 respectively.

Dimensions	A	B	C	D	E	F	G	H	I	J	K	Mass
mm (inch)												kg (lb)
C-8-4	63,5 (2.50)	31,8 (1.25)	82,6 (3.25)	38,1 (1.50)	19,1 (0.75)	3,2 (0.13)	29,8 (1.17)	15,5 (0.61)	7,1 (0.28)	9,6 (0.38)	44,0 (1.73)	0,8 (1.76)
C-10-4	76,2 (3.00)	38,1 (1.50)	88,9 (3.50)	50,8 (2.00)	25,4 (1.00)	9,5 (0.37)	36,6 (1.44)	20,8 (0.82)	7,1 (0.28)	12,7 (0.50)	52,5 (2.07)	0,9 (2.00)
C-12-4	88,9 (3.50)	44,5 (1.75)	127,0 (5.00)	63,5 (2.50)	31,8 (1.25)	10,3 (0.40)	51,6 (2.03)	28,7 (1.13)	8,7 (0.34)	25,4 (1.00)	74,4 (2.93)	1,6 (3.6)
C-16-4	114,3 (4.50)	60,3 (2.37)	139,7 (5.50)	63,5 (2.50)	31,8 (1.25)	10,3 (0.40)	57,0 (2.24)	28,4 (1.12)	8,7 (0.34)	25,4 (1.00)	85,5 (3.37)	2,4 (5.29)
C-20-4	127,0 (5.00)	63,5 (2.50)	177,8 (7.00)	82,5 (3.25)	41,3 (1.63)	10,3 (0.40)	76,5 (3.01)	36,0 (1.42)	8,7 (0.34)	19,0 (0.75)	117,8 (4.63)	4,7 (10.5)

Where measurements are critical request certified drawings. We reserve the right to change specifications without notice.

# C-\*\*-4

## Steel housings (NFPA fatigue rated)

Housing	Ports 1, 2, 3 & 4	Part number	Code
C-8-4	1/4" BSPP	02-160751	(S)2G
	3/8" BSPP	02-160752	(S)3G
	SAE 4	02-160753	(S)4T
	SAE 6	02-160754	(S)6T
C-10-4	1/4" BSPP	02-175139	(S)2G
	3/8" BSPP	02-175140	(S)3G
	SAE 6	02-175137	(S)6T
C-16-4	SAE 8	02-175138	(S)8T
	1/2" BSPP	02-175143	(S)4G
	3/4" BSPP	02-175144	(S)6G
C-20-4	SAE 10	02-175141	(S)10T
	SAE 12	02-175142	(S)12T
	1/2" BSPP	02-175147	(S)4G
	3/4" BSPP	02-175148	(S)6G
	SAE 12	02-175145	(S)12T
	SAE 16	02-175146	(S)16T

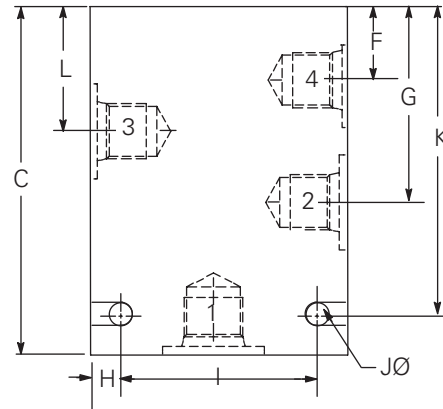
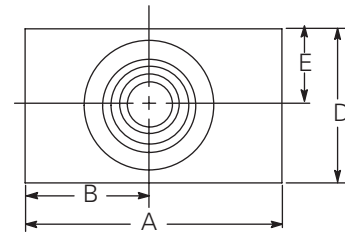

**Notes:** BSPP porting is designated by "G" in the model code SAE porting is designated by "T" in the model code 8 series utilize slot in place of mounting hole.

Fatigue rated steel housings are intended for applications up to 350 bar (5000 psi) with harsh duty cycles. These housings have been fatigue rated to NFPA standards to one million cycles.

For C-10-4 and C-12-4 housings for VCB valves see pages J-24 & J-27 respectively.

Dimensions	A	B	C	D	E	F	G	H	I	J	K	L	Mass
mm (inch)													kg (lb)
C-8-4*	63,5 (2.50)	31,8 (1.25)	82,6 (3.25)	38,1 (1.50)	19,1 (0.75)	15,5 (0.61)	44,0 (1.73)	3,3 (0.13)	57,1 (2.25)	7,1 (0.28)	73,0 (2.88)	29,8 (1.17)	1,2 (2.70)
C-10-4	76,2 (3.00)	38,1 (1.50)	88,9 (3.50)	44,4 (1.75)	22,2 (0.87)	19,1 (0.75)	50,8 (2.00)	9,5 (0.37)	57,1 (2.25)	7,1 (0.28)	76,2 (3.00)	34,9 (1.37)	1,9 (4.35)
C-16-4	101,6 (4.00)	50,8 (2.00)	139,7 (5.50)	50,8 (2.00)	25,4 (1.00)	25,4 (1.00)	82,5 (3.25)	12,7 (0.50)	76,2 (3.00)	10,3 (0.40)	120,6 (4.75)	53,9 (2.12)	5,6 (12.40)
C-20-4	114,3 (4.50)	57,1 (2.25)	177,8 (7.00)	63,5 (2.50)	31,8 (1.25)	31,8 (1.25)	113,5 (4.47)	19,1 (0.75)	76,2 (3.00)	11,8 (0.47)	152,4 (6.00)	72,1 (2.84)	8,2 (18.20)

\* 8 Series housings utilize slot instead of mounting holes.

Where measurements are critical request certified drawings. We reserve the right to change specifications without notice.

Housing	Ports 2,3,4	Port 1,5	Aluminum part number	Code	Steel part number	Code
C-12-5S	SAE 10	SAE 4	4998820-001	(A)10T	4998821-001	(S)10T
	SAE 12	SAE 4	4998820-002	(A)12T	4998821-002	(S)12T
	1/2" BSPP	1/4" BSPP	4998820-003	(A)04G	4998821-003	(S)04G
	3/4" BSPP	1/4" BSPP	4998820-004	(A)06G	4998821-004	(S)06G
C-16-5S	SAE 12	SAE 4	4994880-001	(A)12T	4994881-001	(S)12T
	SAE 16	SAE 4	4994880-002	(A)16T	4994881-002	(S)16T
	3/4" BSPP	1/4" BSPP	4994880-003	(A)06G	4994881-003	(S)06G
	1" BSPP	1/4" BSPP	4994880-004	(A)08G	4994881-004	(S)08G
C-20-5S	SAE 12	SAE 4	4998822-001	(A)12T	4998823-001	(S)12T
	SAE 16	SAE 4	4998822-002	(A)16T	4998823-002	(S)16T
	3/4" BSPP	1/4" BSPP	4998822-003	(A)06G	4998823-003	(S)06G
	1" BSPP	1/4" BSPP	4998822-004	(A)08G	4998823-004	(S)08G

**Notes:** BSPP porting is designated by "G" in the model code SAE porting is designated by "T" in the model code.

Fatigue rated aluminum and steel housings are intended for applications up to 210 bar (3000 psi) and 350 bar (5000 psi) respectively with harsh duty cycles. These housings have been fatigue rated to NFPA standards to one million cycles.

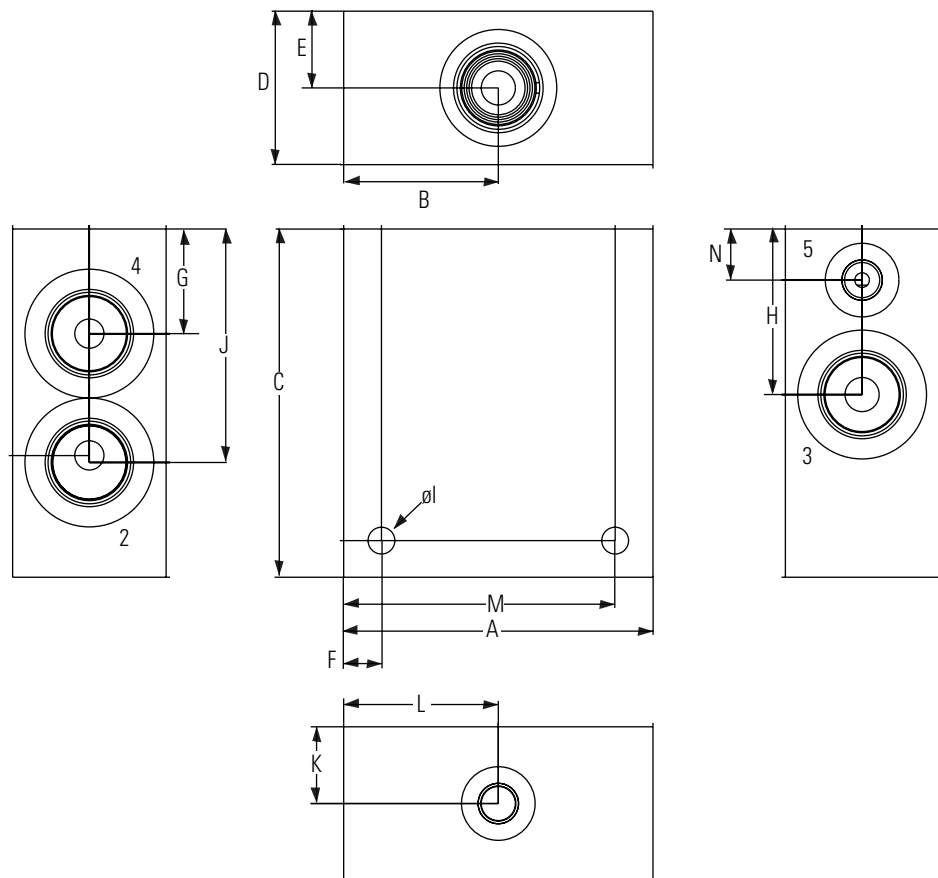

Dimensions	A	B	C	D	E	F	G	H	DIA. I	J	K	L	M	N
<b>mm (inch)</b>														
C-12-5S	100.8 (3.97)	50.4 (1.99)	113.5 (4.47)	50 (1.97)	25 (0.99)	12.3 (0.49)	34.1 (1.34)	54 (2.13)	8.7 (0.34)	76.1 (3.00)	25 (0.99)	50.4 (1.99)	88.5 (3.49)	16.7 (0.66)
C-16-5S	113.5 (4.47)	56.8 (2.24)	126.2 (4.97)	62.7 (2.47)	31.4 (1.24)	9.5 (0.38)	36.1 (1.42)	58.7 (2.31)	8.7 (0.34)	85.7 (3.38)	31.4 (1.24)	56.8 (2.24)	104.8 (4.13)	16.9 (0.66)
C-20-5S	126.2 (4.97)	63.1 (2.49)	138.9 (5.47)	75.4 (2.97)	37.7 (1.49)	12.7 (0.50)	37.6 (1.48)	62.3 (2.45)	10.3 (0.40)	87.4 (3.44)	37.7 (1.09)	63.1 (2.49)	114.3 (4.50)	16.8 (0.66)

Where measurements are critical request certified drawings. We reserve the right to change specifications without notice.

## Port dimensions

Key dimensions in all standard housings

SAE Size	Thread size	Minimum spotface $\varnothing$	Minimum full thd depth
4	0.437"-20 UNF-2B	21,1 (0.82)	11,5 (0.45)
6	0.563"-18 UNF-2B	24,7 (0.96)	12,7 (0.50)
8	0.750"-16 UNF-2B	30,2 (1.18)	14,2 (0.56)
10	0.875"-14 UNF-2B	34,2 (1.34)	16,6 (0.65)
12	1.062"-12 UN-2B	41,3 (1.62)	19,0 (0.75)
16	1.312"-12 UN-2B	48,6 (1.91)	19,0 (0.75)

BSP thread size	Minimum spotface $\varnothing$	Minimum full thd depth
1/4"	24 (0.94)	12,2 (0.48)
3/8"	27 (1.06)	12,2 (0.48)
1/2"	33 (1.29)	15,0 (0.59)
3/4"	42 (1.65)	16,3 (0.64)
1"	47 (1.85)	19,1 (0.75)

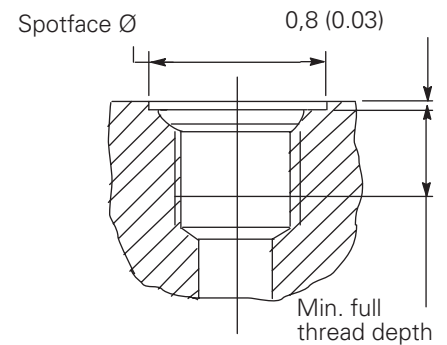



## Standard plugs

### C-\*\*-2 Cavity Plugs

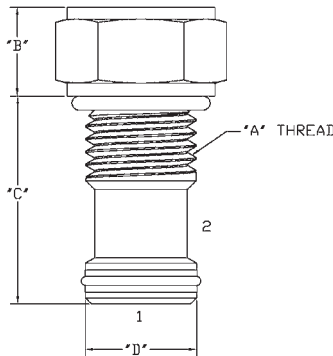

Size	To fit cavity				Assy. no.	Seal kit
	A	B	C	øD		Buna-N Viton®
C-4-2	0.4375"-20	5,1 (0.20)	21,8 (0.86)	8,61/8,66 (0.339/0.341)	5986597-001	9900174-000 9900175-000
C-8-2	0.750"-16	9,1 (0.36)	27,4 (1.08)	12,6/12,5 (0.498/0.496)	02-171585	02-165877 02-165875
C-10-2	0.875"-14	7,9 (0.31)	31,7 (1.25)	15,8/15,7 (0.62/0.62)	565814	565806 889627
C-12-2	1.062"-12	18,7 (0.74)	44,5 (1.75)	23,7/23,7 (.936/.934)	02-171710	02-165889 02-165888
C-16-2	1.312"-12	12,7 (0.50)	44,7 (1.76)	28,5/28,5 (1.12/1.12)	565816	889631 889635
C-20-2	1.625"-12	13,5 (0.53)	57,2 (2.25)	36,4/36,4 (1.43/1.43)	566440	889639 889643

**Note:** To block flow from between the ports in any unused standard cavity, in a housing or manifold. Order cavity plugs by part number.

### C-\*\*-3(S) cavity plugs

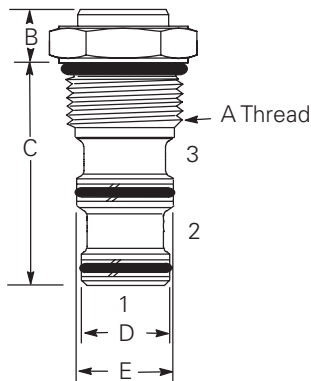

Size	To fit cavity					Assy. no.	Seal kit
	A	B	C	D	E		Buna-N Viton®
C-4-3	0.4375"-20	5,1 (0.20)	37,3 (1.47)	7,82/7,87 (0.308/0.310)	8,61/8,66 (0.339/0.341)	5986599-001	9900176-000 9900177-000
C-8-3	0.750"-16	9,1 (0.36)	40,7 (1.60)	14,2/14,0 (0.56/0.55)	15,8 (0.623/0.621)	02-171708	02-160755 02-160765
C-10-3S	0.875"-14	7,9 (0.30)	74,2 (1.86)	17,4/17,4 (0.68/0.68)	19,0/18,9 (0.74/0.74)	566436	02-173019 02-173020
C-10-3			46,0 (1.81)	15,8/15,7 (0.62/0.62)	17,4/17,3 (0.68/0.68)		
C-12-3S	1.062"-12	18,7 (0.74)	57,7 (2.27)	22,1/22,1 (0.874/0.872)	23,7/23,7 (0.936/0.934)	02-171711	02-180095 02-165887
C-12-3			67,1 (2.64)	-	-		
C-16-3S	1.312"-12	12,7 (0.50)	55,6 (2.18)	25,3/25,3 (0.99/0.99)	28,5/28,5 (1.2/1.2)	566438	889633 889637
C-16-3			73,1 (2,87)	26,9/26,9 (1.06/1.06)	28,5/28,5 (1.2/1.2)		
C-20-3S	1.625"-12	13,5 (0.53)	76,2 (3.0)	33,3/33,2 (1.31/1.30)	36,4/36,4 (1.43/1.43)	566442	02-113153 02-112969
C-20-3			98,5 (3.87)	33,3/33,2 (1.31/1.30)	36,4/36,4 (1.43/1.43)		

**Note:** C-16-2 cavity plug can be used to block port 3 of C-16-3

Where measurements are critical request certified drawings. We reserve the right to change specifications without notice.

# Cavity plugs

## C-\*\*-4 cavity plugs

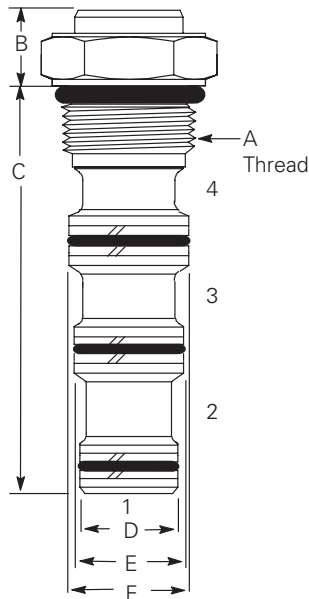

To Fit cavity size	A	B	C	D	øE	øF	øG	Assy no.
C-8-4	0.750"-16	22,2 (0.87) hex. Torque 35-40 Nm(25-30 lbf ft)	8,6 (0.34)	54,6 (2,15)	12,6 (0.49)	14,2 (0.55)	15,8 (0.62)	02-171709
C-10-4(U)	0.875"-14	25,4 (1.0) hex. Torque 47-54 Nm (35-40 lbf ft)	7,9 (0.31)	61,9 (2.43)	15,8/15,7 (0.62/0.62)	17,4/17,3 (0.68/0.68)	19,0/18,9 (0.74/0.74)	566244
C-16-4	1.312"-12	38,1 (1.50) hex. Torque 109-122 Nm (80-90 lbf ft)	12,7 (0.50)	101,6 (4.00)	25,3/25,3 (0.99/0.99)	26,9/26,9 (1.06/1.05)	28,5/28,5 (1.12/1.12)	566439
C-20-4	1.625"-12	47,6 (1.87) hex. Torque 129-156 Nm (95-115 lbf ft)	13,5 (0.53)	139,7 (5.50)	31,7/31,6 (1.24/1.24)	33,3/33,2 (1.31/1.30)	36,4/36,4 (1.43/1.43)	566443

**⚠ Important**  
The cartridges listed are complete with seals compatible with antiwear hydraulic oil. If cartridges are to be compatible with antiwear

and phosphate ester, order cartridges by part number plus the appropriate Viton seal kit as listed in Spare parts. Before using the cartridge, change the seals to Viton.

## Special purpose cavity plugs

### Functional symbols

Filter cartridge plugs

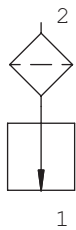

### Special 3 way cavity plugs

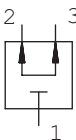
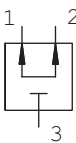

### Special 4 way cavity plugs

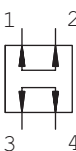

To fit cavity size	Assy. no.	Seal kit
C-10-2	02-186758	566806 (Buna-N) 889627 (Viton®)

Screen fitted on cartridge, intended direction of flow is from port 2 to 1 only. Maximum rated flow is 76 L/min (20 USgpm), maximum operating pressure is 350 bar (5000 psi)

To fit cavity size	Assy. no.	Seal kit
C-8-3	02-186664	02-160755 (Buna-N) 02-160756 (Viton®)
C-10-3S	02-185257	02-173019 (Buna-N) 02-173020 (Viton®)

To fit cavity size	Assy. no.	Seal kit
C-10-3	02-161831	889624 (Buna-N) 889628 (Viton®)

To fit cavity size	Assy. no.	Seal kit
C-8-4	02-179151	02-160757 (Buna-N) 02-160758 (Viton®)

Where measurements are critical request certified drawings. We reserve the right to change specifications without notice.

# ECF - Pressure filters

Flows to 19 L/min (5 USgpm) • Pressures to 207 bar (3000 psi)



## Features and benefits

- Integrated disposable element which is screwed into the manifold port for last chance filtration
- Catches particles in a variety of sizes (20, 50, 70 microns)
- Universally adaptable to all sizes of standard manifolds

## Design Specifications

Rated flow	19 L/min (5 USgpm)	
Fluid compatibility	Compatible with all petroleum, oil based and synthetic fluids. Not rated for use with fluoro-rubber or ethylene propylene seals.	
Temp range	-30°C to +121°C (-22°F to 250°F)	
Collapse pressure rating	10 bar (145 psi)	
Cavity	BC20-S3	
Material	Head	Aluminum
	Bowl	Aluminum
Dry weight	0.11 kg (0.25 lbs)	

## Filter and element model code

### Sample model code

ECF1SB1J3CB25

ECF 1 SB 1 J 3 C \* \*\*

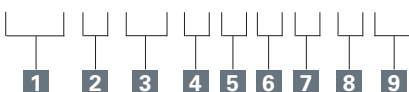

### 1 Filter Series - ECF

### 6 Assembly length

3 – 80.2mm (3.157")

### 2 Element collapse rating

1 – 250 PSI low collapse

### 7 Element construction

C – Standard construction

### 3 Port options

SB – 1.312-12 UN SAE-16 straight thread 1" O.D. tube

### 8 Seal material

B – Buna-N  
V – Viton-A

### 4 Valve options

1 – Non-Bypass (Screw directly into cavity)

### 9 Fluid cleanliness

### 5 Indicator options

J – No indicator

Code	Fluid cleanliness rating	Element construction
15	20/18/15	C-Pak
25		Wirescreen
149		Wirescreen

Where measurements are critical request certified drawings. We reserve the right to change specifications without notice.

# ECF - pressure filters

Flows to 19 L/min (5 USgpm) • Pressures to 207 bar (3000 psi)

## Cavity dimensions (BC20-S3)

inch

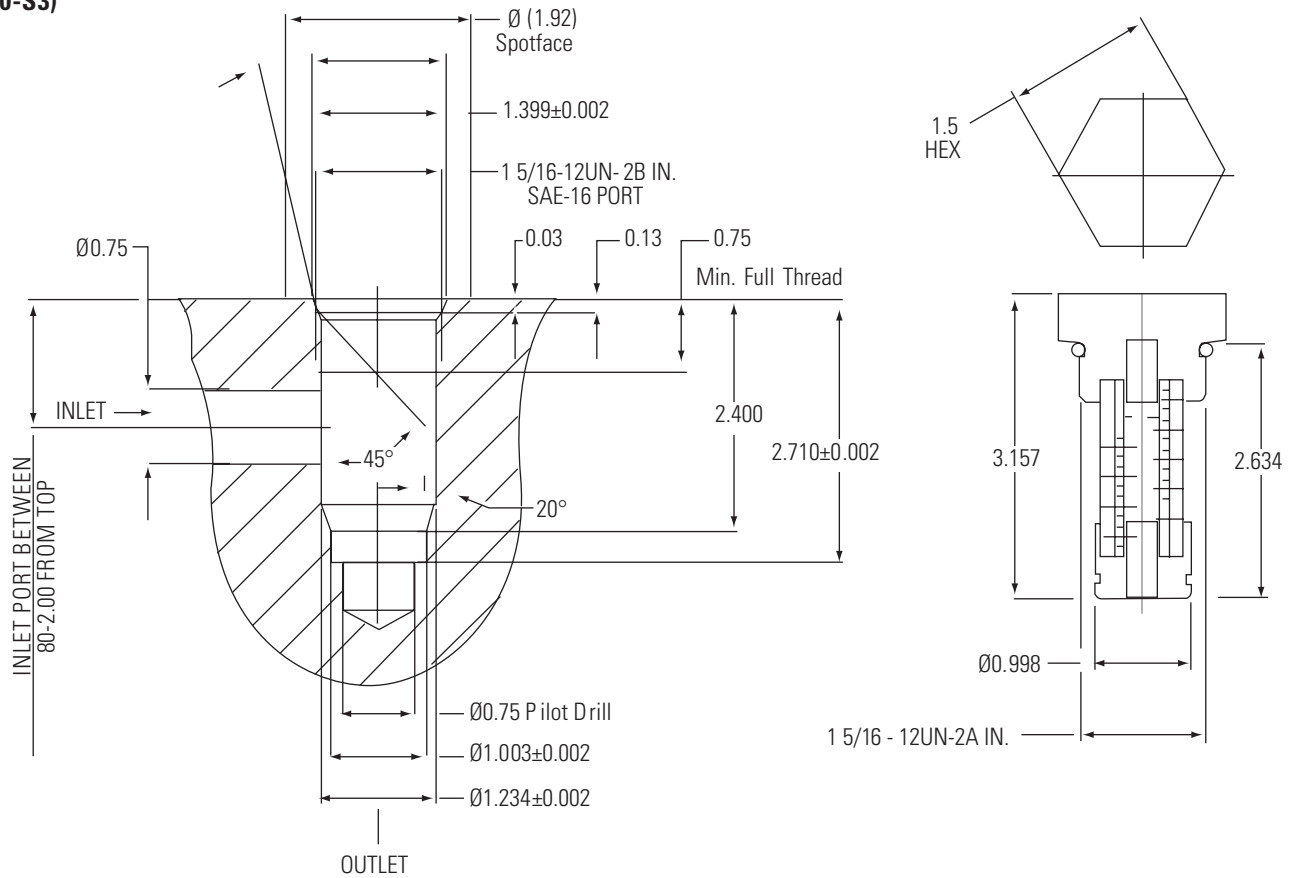

## Housing/element flow data

### Flow versus pressure drop:

150 SUS (32 cSt) oil with specific gravity of < 0.9

ECF-15

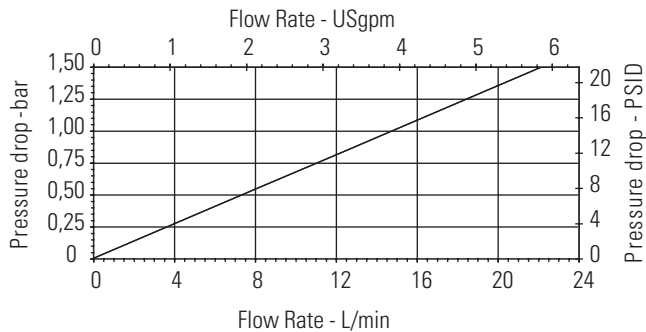

Where measurements are critical request certified drawings. We reserve the right to change specifications without notice.

## Blank orifice discs (flat)

**Note:** For predrilled orifice discs, consult factory.

An orifice disc is installed at the bottom of a standard cavity to create a local pressure drop in the flow to and from port 1 of the cartridge.

Two series of discs are available according to the maximum pressure drop required:

1. Flat discs/maximum pressure drop/13,8 bar (200 psi).
2. Conical discs/maximum pressure drop/210 bar (3000 psi).

Cavity sizes	Max pressure drop bar (psi)	øA	B	øC	Assy number
C-8-2/4	13,8 (200)	12,45 (0.490)	1,27 (0.050)	*	02-163254
C-10-2/3/4	13,8 (200)	5,80 (0.622) 15,75 (0.620)	1,52 (0.060)	*	02-162850
C-16-2	13,8 (200)	28,58 (1.125) 28,52 (1.123)	2,03 (0.08)	*	566247
C-16-3	13,8 (200)	26,97 (1.062) 26,92 (1.060)	2,03 (0.08)	*	02-162872
C-16-3S/4	13,8 (200)	25,4 (1.00) 25,35 (0.998)	2,03 (0.08)	*	02-174504

\*User to specify

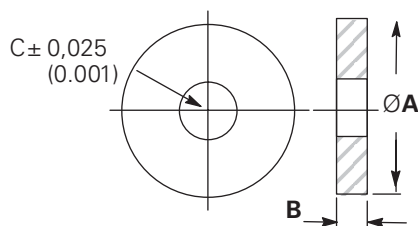

## Blank orifice discs (conical)

Cavity sizes	Max pressure drop bar (psi)	øA	øB	øC	d	E	F	Assy number
C-8-2/4	210 (3000)	3,96 (0.156)	5,84 (0.230)	12,45 (0.490)	1,90 (0.075)	3,05 (0.120)	–	02-174854
C-8-3	210 (3000)	3,96 (0.156)	5,84 (0.230)	14,05 (0.553)	1,90 (0.075)	3,05 (0.120)	–	02-178181
C-10-2	210 (3000)	5,54 (0.218)	6,35 (0.250)	15,80 (0.622) 15,75 (0.620)	1,14 (0.045)	3,56 (0.140)	–	566478
C-12-2	210 (3000)	7,14 (0.281)	–	23,70 (0.933) 23,65 (0.931)	2,41 (0.095)	3,56 (0.140)	1,14 (0.045)	02-182842

Orifice diameter  
± 0,025 (0.001)

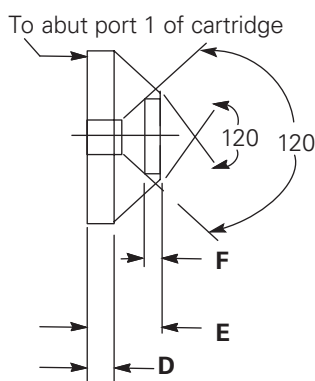
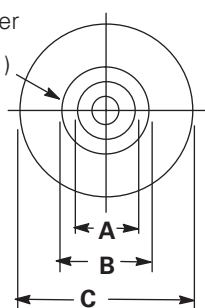

Where measurements are critical request certified drawings. We reserve the right to change specifications without notice.

# Orifice disc - sizing guide (mm)

Select required orifice diameter using the graph below

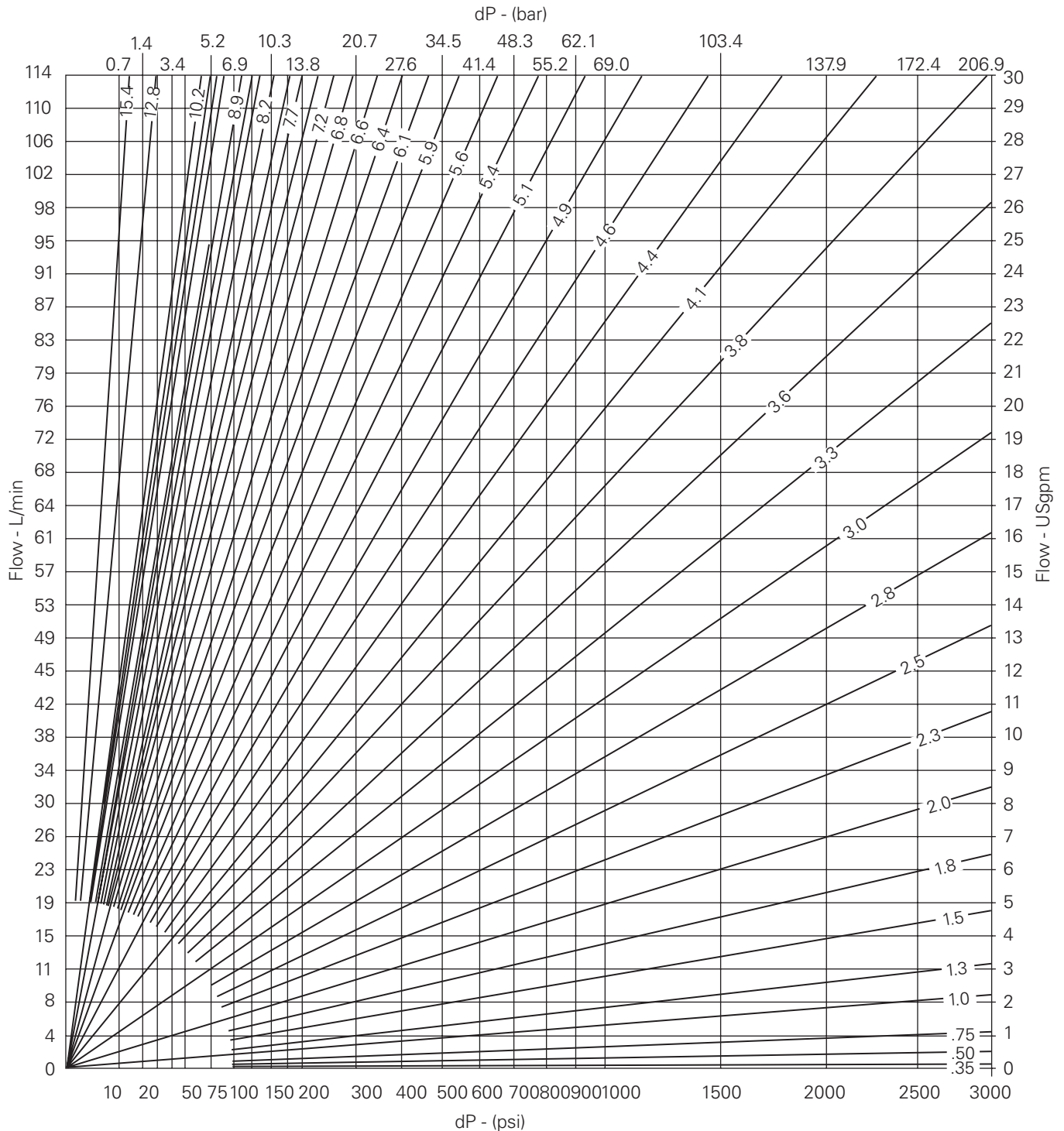

**Notes:**

This chart is calculated at 21.8 cSt and 49°C for ISO VG32 fluid (DTE-24), values will change with viscosity changes.

To calculate orifice diameter at other flows and differential pressures use the following formula:

$$D = 1.350 \times \sqrt{Q / (\sqrt{\Delta P})}$$

where **D**= orifice diameter in inches; **Q**= flow in US gallons per minute; **ΔP**= differential pressure across orifice in bar.

Where measurements are critical request certified drawings. We reserve the right to change specifications without notice.

# Orifice disc - sizing guide (inches)

Select required orifice diameter using the graph below

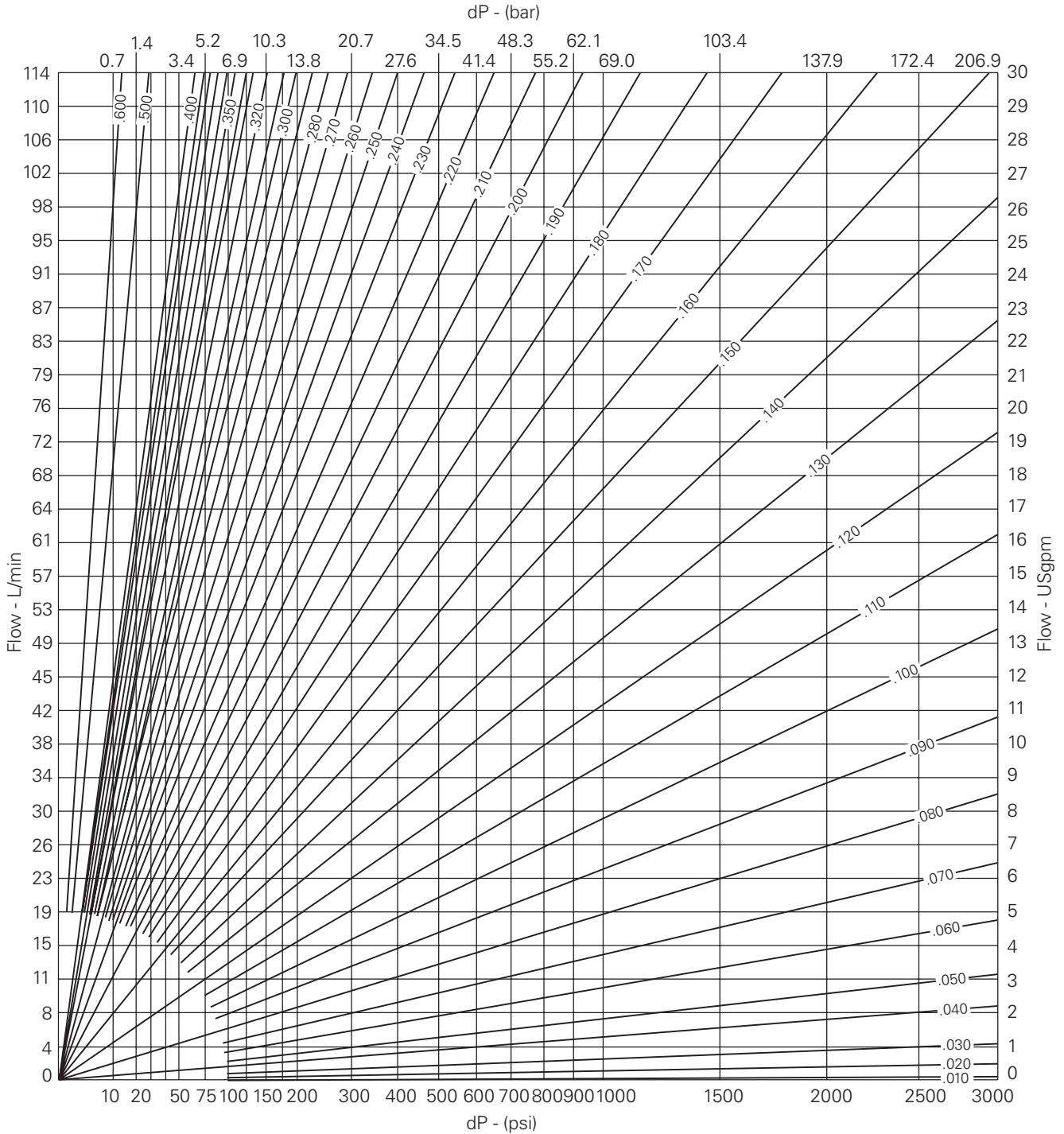

**Notes:**

This chart is calculated at 105 SUS and 120°F for ISO VG32 fluid (DTE-24), values will change with viscosity changes.

To calculate orifice diameter at other flows and differential pressures use the following formula:

$$D = 0.203 \times \sqrt{Q / (\sqrt{\Delta P})}$$

where **D**= orifice diameter in inches; **Q**= flow in US gallons per minute; **ΔP**= differential pressure across orifice in PSI.

Where measurements are critical request certified drawings. We reserve the right to change specifications without notice.

# Pilot pistons

## Pilot piston assemblies dimensions

Nominal cartridge size	Single or double acting	With or without stops	A	B	C	Required housing bore
8	Single	Without	15,1 (0.60)	34,1(1.34)	8,3 (0.33)	12,73 (0.500)
	Double	Without	15,1 (0.60)	53,2 (2.10)	8,3 (0.33)	12,75 (0.502)
10	Single	Without	19,1 (0.75)	41,3 (1.63)	13,5 (0.53)	15,88 (0.625)
	Double	Without	19,1 (0.75)	57,2 (2.25)	10,3 (0.41)	15,88 (0.625)
	Single	With	19,1 (0.75)	45,7 (1.80)	6,7 (0.26)	15,90 (0.626)
	Double	With	19,1 (0.75)	54,8 (2.16)	6,7 (0.26)	15,90 (0.626)
12	Single	Without	17,5 (0.69)	44,5 (1.75)	14,3 (0.56)	23,80 (0.937)
	Double	Without	17,5 (0.69)	71,4 (2.81)	14,3 (0.56)	23,85 (0.939)
16	Single	Without	31,8 (1.25)	63,5 (2.50)	12,7 (0.50)	28,58 (1.125)
	Double	Without	31,8 (1.25)	95,3 (3.75)	12,7 (0.50)	28,60 (1.126)
20	Single	Without	38,1 (1.50)	77,8 (3.06)	19,0 (0.75)	36,50 (1.437)
	Double	Without	38,1 (1.50)	117,5 (4.63)	19,0 (0.75)	36,53 (1.438)

**Note:** Use with cartridges to form pilot operated check and similar functions in HIC and standard valve packages.

### ⚠ Warning

The use of pilot pistons with check valve assemblies may increase the load applied to the valve poppet which may result in reduced fatigue life of the cartridge

## Part numbers

Nominal cartridge size	Single or double acting	With or without stops	Piston with buna-N seals	Piston with viton® seal	Piston without seals
8	Single	Without	02-178662	02-178663	02-178653
	Double	Without	02-178669	02-178670	02-178654
10	Single	Without	02-166275	566418	566417
	Double	Without	566419	566420	02-166313
	Single	With	566421	566422	566337
	Double	With	566423	566424	566338
12	Single	Without	02-185700	02-185701	02-185699
	Double	Without	02-185703	02-185704	02-185702
16	Single	Without	566425	566426	889052
	Double	Without	566428	566429	566427
20	Single	Without	566431	566432	566430
	Double	Without	566434	566435	566433

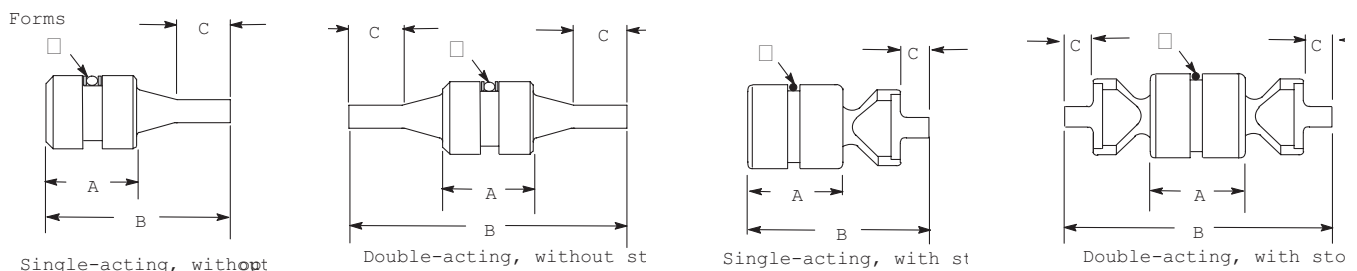

### Note:

ψ Sealed models have a central O-ring with a back-up ring on both sides.

### ⚠ WARNING

Seals should not be used with check valves that have < 50 psi crack pressure

Where measurements are critical request certified drawings. We reserve the right to change specifications without notice.



# Sensing check/panel mount adapter

## Sensing check

Sensing check kits can be built into customized manifolds to permit pilot control from two or more alternate sources, as example here:

## Kit part numbers

Sense Check kit	Part. no.
with Buna-N seals	566395
with Viton® seals	02-183199

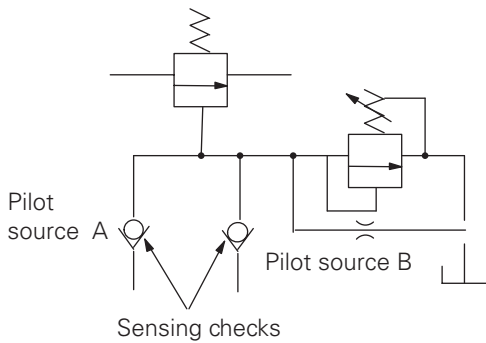
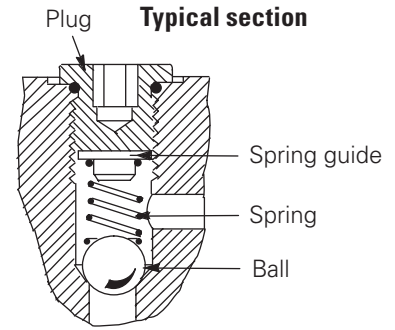

## Sensing check cavity

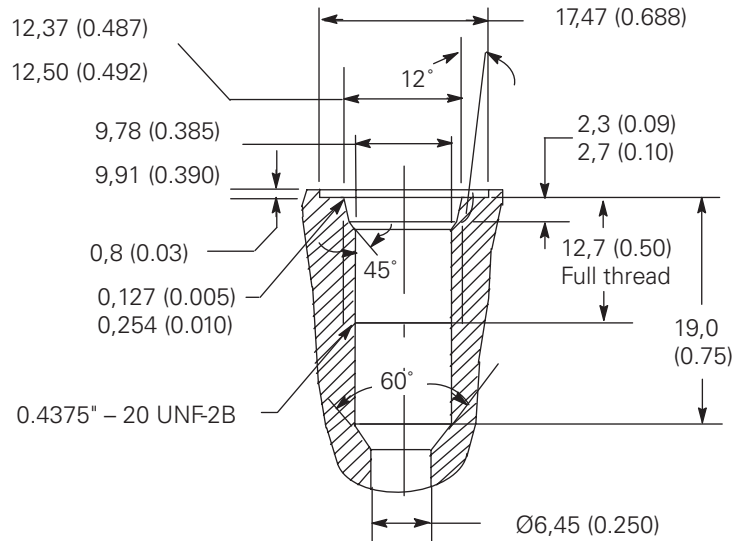

## Panel mount adapter for 10 & 12 series valves

Used for mounting an adjustable pressure valve through a bulkhead or panel surface.

## Part number 02-161837

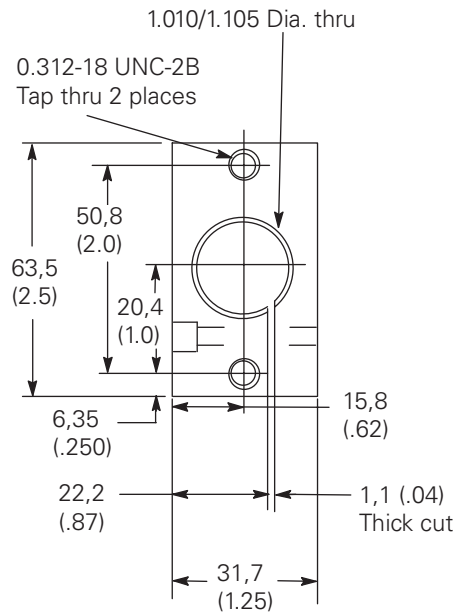
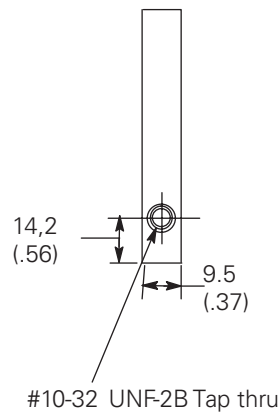
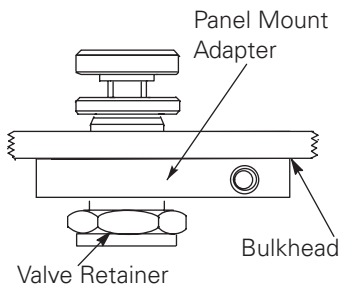

Where measurements are critical request certified drawings. We reserve the right to change specifications without notice.

# Miscellaneous parts

## Solenoid valve parts

### Note:

When a solenoid valve is ordered as a cartridge only, the nut is included.

Description	Part number
<b>Nut for standard core tube valves</b>	
8 Series	02-170821
10, 12, 16, 20 Series and SV9-8	565558
10, 12, 16, 20 Series 350 bar valves	02-175698
<b>Coil Spacers</b>	
Spacer for SV9-8	02-186730
Spacer for SV9-10	02-179226
<b>Nut for extended core tube valves</b>	
	565559



Nut for standard core tube valves.



Nut for extended core tube valves.

## Spare parts

<b>SPC1/DPC1/11</b>				
Model code	Check valve (Qty)	Pilot piston (QTY)	Buna-N seal kit	Viton® seal kit
SPC1-10-P	CV1-10(V)-P-0-15 (1)	566417 (1)	565803	566086
SPC1-16-P	CV1-16(V)-P-0-20 (1)	889052 (1)	565810	889609
SPC1-20-P	CV2-20(V)-P-0-15 (1)	566430 (1)	889615	889619
DPC1-10-P	CV1-10(V)-P-0-15 (2)	02-166313 (1)	565803	566086
DPC11-12-P	CV11-12(V)-P-0-15 (2)	02-185702 (1)	02-165889	02-165888
DPC1-16-P	CV1-16(V)-P-0-20 (2)	566427 (1)	565810	889609
DPC1-20-P	CV2-20(V)-P-0-15 (2)	566433 (1)	889615	889619

<b>MCV</b>						
Model code	Check valve	(Qty)	Relief valve	(Qty)	Piston	(Qty)
MCV1-16	CV1-16-P-0-5	(1)	RV3-16-S-0-35/	(1)	889052	(1)
MCV4-16	CV1-16-P-0-5	(4)	RV3-16-S-0-35/	(2)	889052	(2)
MCV1-20	CV2-20-P-0-5	(1)	RV3-16-S-0-35/	(1)	889052	(1)
MCV2-20	CV2-20-P-0-5	(2)	RV3-16-S-0-35/	(2)	889052	(2)

## Adjustment kits

<b>PFR2-16 Series Knob Kit</b>	
Description	Part number
<b>K</b> (Knob kit)	565586
Knob	02-162137
Jam nut	02-170637
Set screw	000805

<b>FCV7,FCV6,FR2, Series Knob Kit</b>	
Description	Part number
<b>K</b> (Knob kit)	565585
Knob	02-165873*
Jam nut	02-170635*
Set screw	001016*

\* Supplied as part of kit 565585

<b>NV1 8-series</b>	
Description	Part number
<b>C</b> (Cap kit):	02-170163
Cap	02-170163
Nut	02-170161
<b>K</b> (Knob kit)	02-171892
Knob	02-174439
Jam nut	02-174515
Set screw	001016

<b>S Kit:</b>	
Description	Part number
Nut	02-170159

<b>Mcv series knob kit</b>	
Description	Part number
<b>K</b> (Knob kit):	565586
Knob	02-162137*
Jam nut	02-170637*
Set screw	000805*
<b>S (nut)</b>	565558

\* Supplied as part of kit 565586

<b>FCV11-12-S series knob kit</b>	
Description	Part number
<b>K</b> (Knob kit):	565585
Knob	02-184877
Jam nut	02-184878
Set screw	001016*

\* Supplied as part of kit 565585

Where measurements are critical request certified drawings. We reserve the right to change specifications without notice.

## Adjustment Kits

(cont.)

NV1 10- Series	Part number
Knob	888963
Acorn nut	02-162993
Nameplate	02-165920

NV1 16-&20-Series	Part number
Knob	02-162130
Acorn nut	02-162992
Nameplate(attached)	02-165922

FAR1-10/12 & 16 series	Part number
Knob kit	02-185169

MRV2-10-D/L, B/E 10-series	Part number
Lever kit:	565610
Hub	02-169085
Lever	888980
Spring	888986
Plunger	02-163705
Insert	02-169956
Spring	888874
Detent pla.	02-170023
Plate supp.	02-165090
Nameplate	888964
Acorn nut	02-162993

MRV2-10-K 10-series	Part number
Knob	888963
Acorn nut	02-162993
Nameplate	888964

MRV2-16-D/L, 16-series	Part number
Lever kit:	565611
Hub	02-169453
Lever	888988
Spring	888986
Plunger	02-163705
Insert	02-170103
Spring	888993
Detent plate	02-170102
Plate supp.	02-161901
Nameplate	02-165922
Acorn nut	02-162992

MRV2-16-K 16- series	Part number
Knob	02-162130
Acorn nut	02-162992
Nameplate	888967

Pressure control, 8-series	Part number
Retaining ring	02-166712
K (Knob kit)	02-170164
Cap	02-162806
Nut	02-170159

Retaining ring is required for C and S controls. When converting from the "S" or "C" option to the "K" option, remove retaining ring and nut before installing the knob kit.

Pressure control, 10 & 12-Series	Part number
C (Cap)	02-170616*
S (Nut)	565558*
K (Knob kit)	565585
Knob	02-165873
Jam nut	02-170635
Set screw	001016

\*These parts also used to service PUV3-10 models.

Pressure control, 16-series	Part number
S (Nut)	565558
RV3 K (Knob kit)	565586
Knob	02-162137
Jam nut	02-170637
Set screw	000805
RV5 K (Knob Kit)	565585
Knob	02-165873
Jam nut	02-160635
Set screw	001016
RV5 C (Cap)	02-170616

**Note:** The only difference between the "D/B" and the "L/E" adjustment option is the orientation of the detent plate.

The B/E options are not available in kit form. The only difference between these and the D/L versions is that the lever is replaced with 02-165925 and an additional 310204 set screw is required.

Where measurements are critical request certified drawings. We reserve the right to change specifications without notice.



An Eaton Brand

## Performance You Deserve From A Name You Trust



When it isn't just a question of being first ...  
But also being the best.

As the only leading supplier to manufacture our hose in our own ISO/QS certified hose plants, you are assured the highest quality and most advanced hose products.

Combining our rich heritage and on-track performance with the industry's largest pool of engineering

resources, Aeroquip Performance Products continues to prove **There is a Difference ...**

To locate an authorized distributor near you, or for more information, visit [www.eaton.com/aeroquipperformance](http://www.eaton.com/aeroquipperformance).



# IHP7 - Hand pump

50 bar (725 psi)

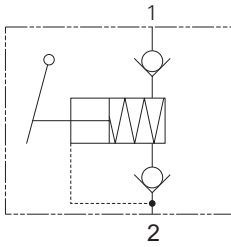

## Description

This hand pump has been designed to be used on machines which require emergency release of brakes or for pilot supply for emergency lowering of access platforms. It can also be utilized in the lubrication circuits.

## Operation

Depressing the plunger will force oil out through a check valve and into the system. The plunger will then retract drawing oil into the chamber through a second check valve.

## Features

Built in pressure and suction checks. Self contained cartridge element. Low leakage ball and seat design. Minimal effort required for plunger movement.

## Sectional view

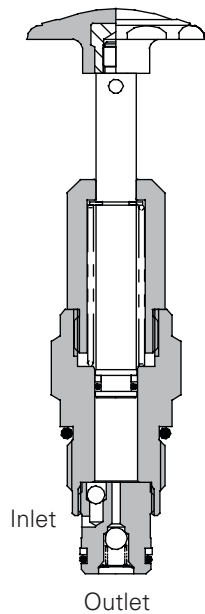

## Performance data

### Ratings and specifications

*Figures based on oil temperature of 40° C and viscosity of 32 cSt (150 SUS)*

Bore Diameter	9.5 mm (0.375")
Stroke	19 mm (0.75")
Displacement	1.3 cc (1.3 ml)/stroke
Generated pressure	50 bar (725 psi)
Cartridge material	Working parts hardened & ground steel
Body material	Zinc plated steel & anodised aluminium
Cavity Number	A12370 (See Section M)
Torque cartridge into cavity	40 Nm (30 lbs ft)
Weight	0.16 kg (0.35 lbs.)
Seal kit number	SK1224 (Nitrile) SK1224V (Viton)
Recommended filtration level	BS5540/4 Class 18/13 (25 micron nominal)
Operating Temperature	-30°C to +90°C (-22° to 194°F)
Leakage	0.3 milliliters/min nominal (5 dpm)
Nominal viscosity range	5 to 500 cSt

Where measurements are critical request certified drawings. We reserve the right to change specifications without notice.

# 1HP7 - Hand pump

50 bar (725 psi)

## Model code

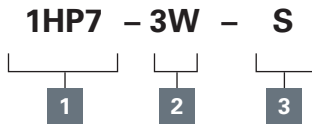

### 1 Basic code

**1HP7** - Cartridge only  
**1HP75** - Cartridge and body

### 2 Port Size

Code	Port size	Aluminum
Omit	Cartridge only	
<b>3W</b>	3/8" BSP	B19053
<b>8T</b>	1/2" SAE	B19402

### 3 Seals

**S** - Nitrile (for use with most industrial hydraulic oils)

**SV** - Viton® (for high temperature & most special fluid applications)

## Dimensions

mm (inch)

Torque cartridge in aluminum housing 108-122 Nm (80-90 ft lbs)

### Cartridge only

Basic Code: 1HP7

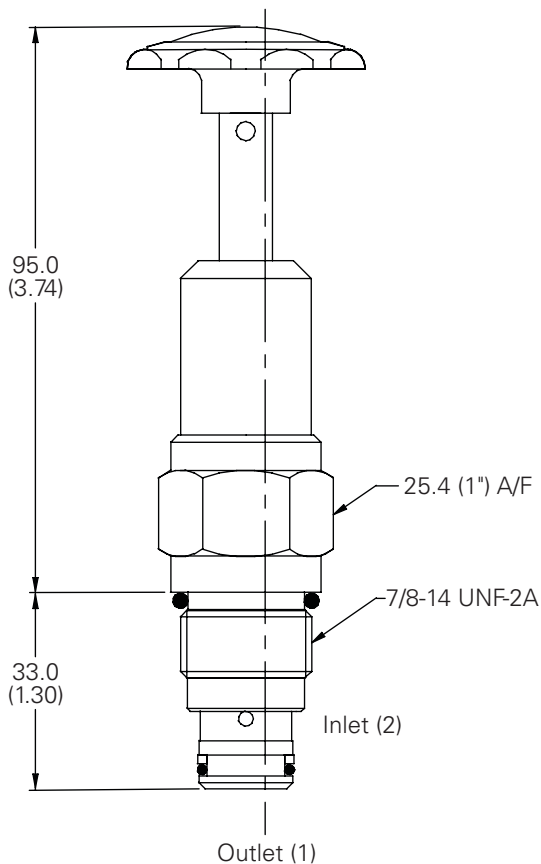

### Installation drawing

Basic Code: 1HP75

3/8" Ports

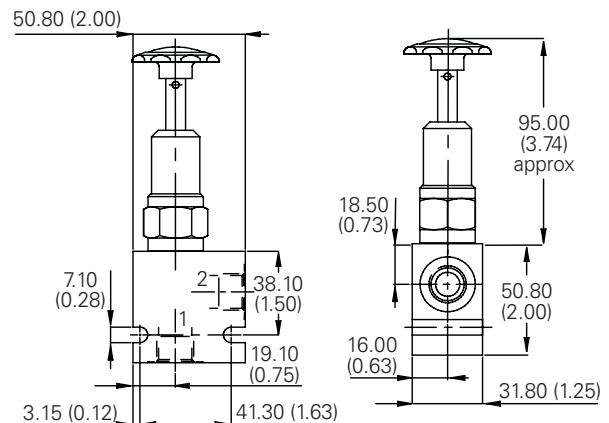

Where measurements are critical request certified drawings. We reserve the right to change specifications without notice.

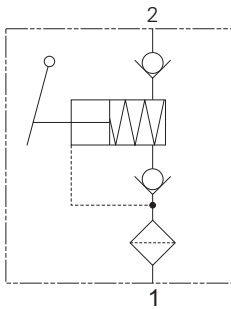

## Operation

Depressing the plunger will force oil out through a check valve and into the system. The plunger will then retract drawing oil into the chamber through a second check valve.

## Features

Built in pressure and suction checks and inlet strainer . Self contained cartridge element. Low leakage ball and seat design. Minimal effort required for plunger movement. Handle rotates on body to suit user.

## Description

This hand pump has been designed to be used on machines which require emergency release of brakes or for pilot supply for emergency lowering of access platforms. It can also be utilized in the lubrication circuits.

## Performance data

### Ratings and specifications

*Performance data is typical with fluid at 32 cST (150 SUS)*

Displacement	1.9cc/stroke
Generated pressure	250 bar (3625 psi)
Cartridge material	Steel with hard chrome piston
Cavity number	A878 (see Section M)
Torque cartridge into cavity	45-50 Nm
Weight	0.8 Kg (1.76 lbs)
Recommended Filtration Level	BS5540/4 Class 18/13 (25 micron nominal)
Operating temperature	-30° to +90° C (-22° to 194° F)
Nominal viscosity range	5 to 500 cSt

# 1HP10 - Hand pump

250 bar (3625 psi)

## Model code

**1HP10 - 3W - S**

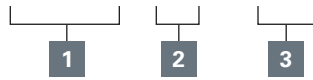

### 1 Basic code

**1HP10** - Cartridge only  
**1HP15** - Cartridge and body

### 2 Port Size

Code	Port Size	Aluminum
Omit	Cartridge only	BXP16234
3W	3/8" BSP	BXP16235
4W	1/2" BSP	BXP16235

### 3 Seals

**S** - Nitrile (for use with most industrial hydraulic oils)

**SV** - Viton® (for high temperature & most special fluid applications)

## Dimensions

mm (inch)

### Cartridge only

Basic Code: 1HP10

## Installation Drawing

Basic Code: 1HP15  
 3/8" Ports

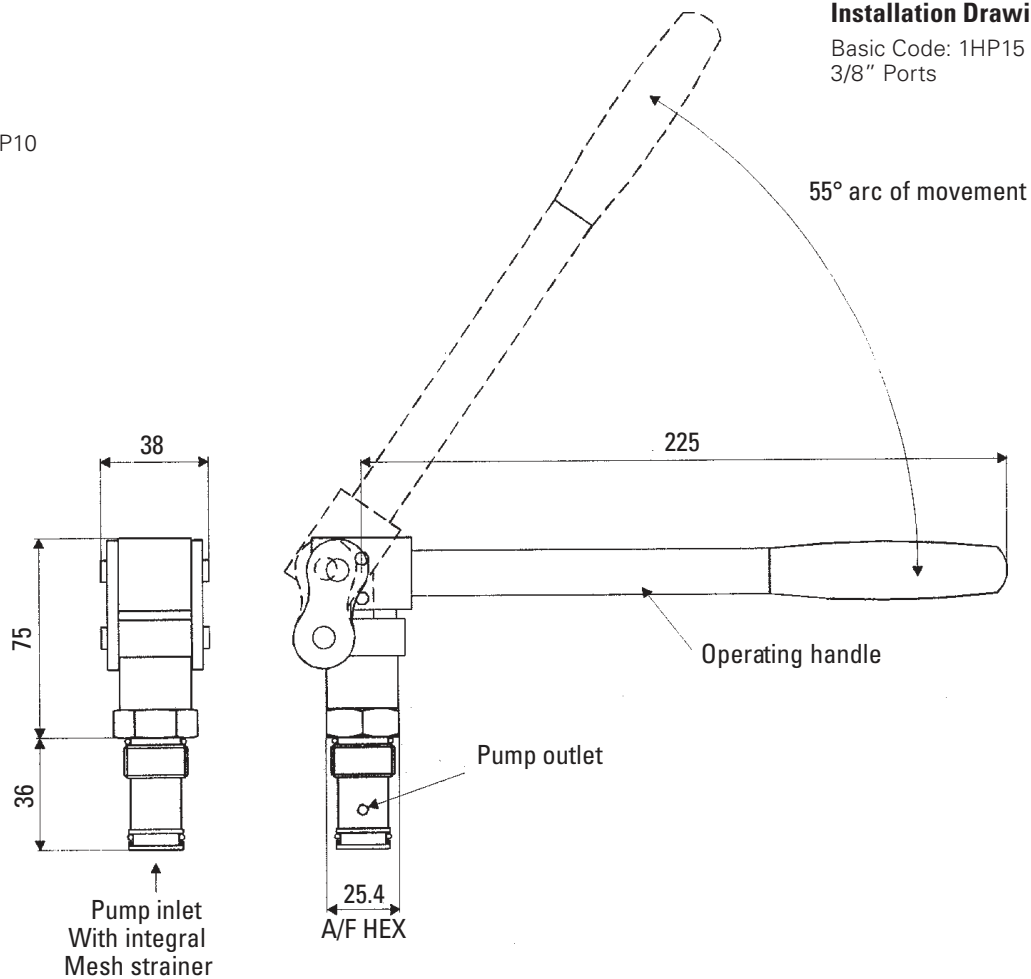

Where measurements are critical request certified drawings. We reserve the right to change specifications without notice.



# 1T162W6S - Pressure intensifier

Hydraulic integrated circuits

## Description

This valve is used to convert low input pressure from a small low pressure pump or sub-circuit to high pressure up to 700 bar (10000 psi) and can eliminate the need for high pressure pump, or high-low type circuit. It is best suited for use with low horsepower, variable volume pumps. Contact main office for full specifications.

## Operation

The pressure intensifier allows free flow of oil through the inlet to the actuator until high pressure is required, then reciprocates to intensify the pressure with a ratio of 6.5-1 between the inlet pressure and the intensified pressure up to a maximum 700 bar. The unit automatically makes up for any leakage to prevent loss of pressure during clamping or cutting operations. The flow to the 'P' port should be regulated to prevent a too rapid cycle rate.

## Features

Eliminates the need for single stroke air/oil systems. Continuous automatic make up for leakage. Light weight and compact. Reliable high quality.

## Max pressure:

Inlet 110 bar (1600 psi)  
Output 700 bar (10,000 psi)

## Rated flow:

Inlet 1.5 L/min (0.4 USgpm)  
Output 165 mL/min  
(10 in<sup>3</sup>/min)

## Functional symbol

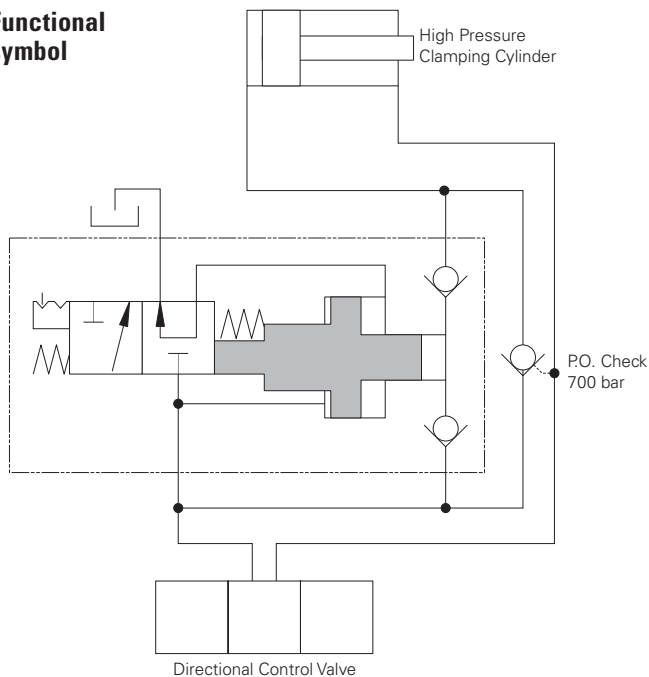

## Dimensions

mm (inch)

## Installation drawing

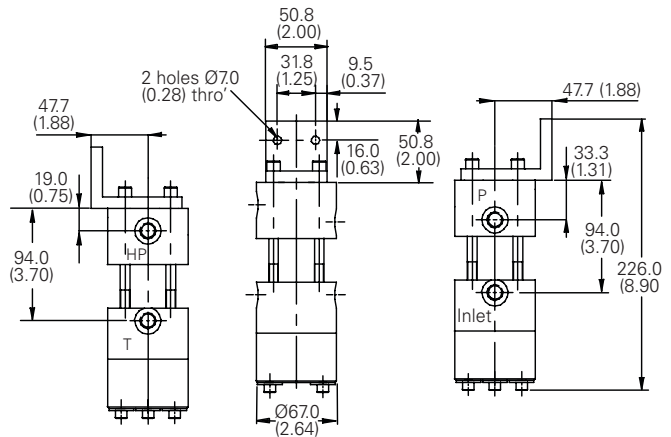

## Model code

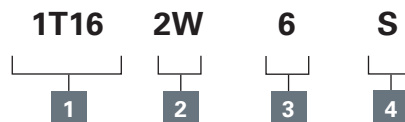

### 1 Basic code

1T16 - Intensifier

### 2 Port sizes

2W - 1/4" BSP

### 3 Pressure intensification ratio

6 - 6:5:1

### 4 Seals

S - Nitrile (for use with most industrial hydraulic oils)

SV - Viton (for high temperature & most special fluid applications)

Where measurements are critical request certified drawings. We reserve the right to change specifications without notice.

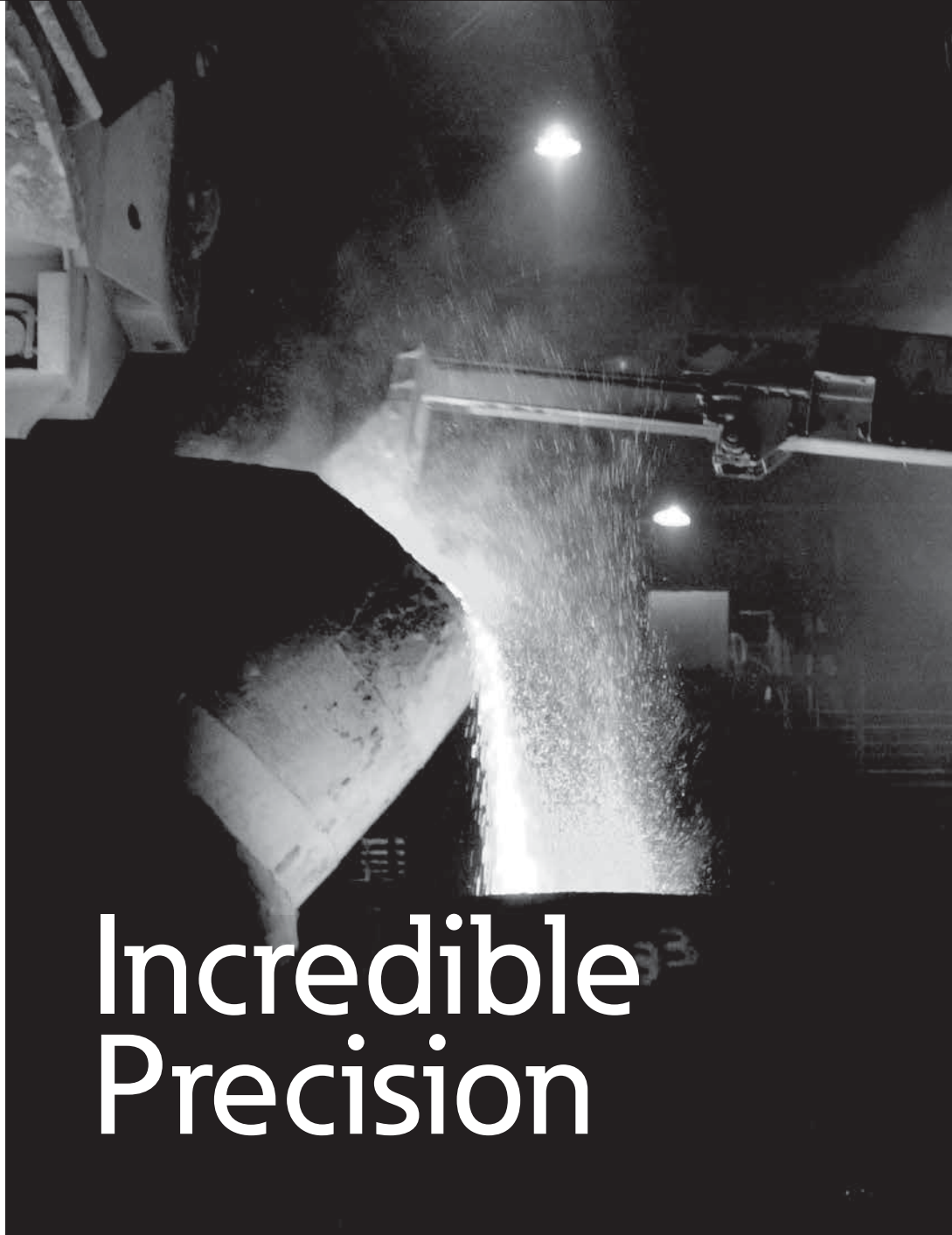

# Incredible Precision



## Hydrokraft Pumps & Motors

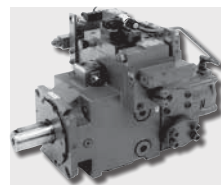

- Hydrokraft Axial Piston Pumps and Motors
- 4cir to 45cir (66ccm to 750ccm)
- Wide Range of Controls