

Danfoss[®]

Medium Duty Piston Pump

August, 1995



Parts Information

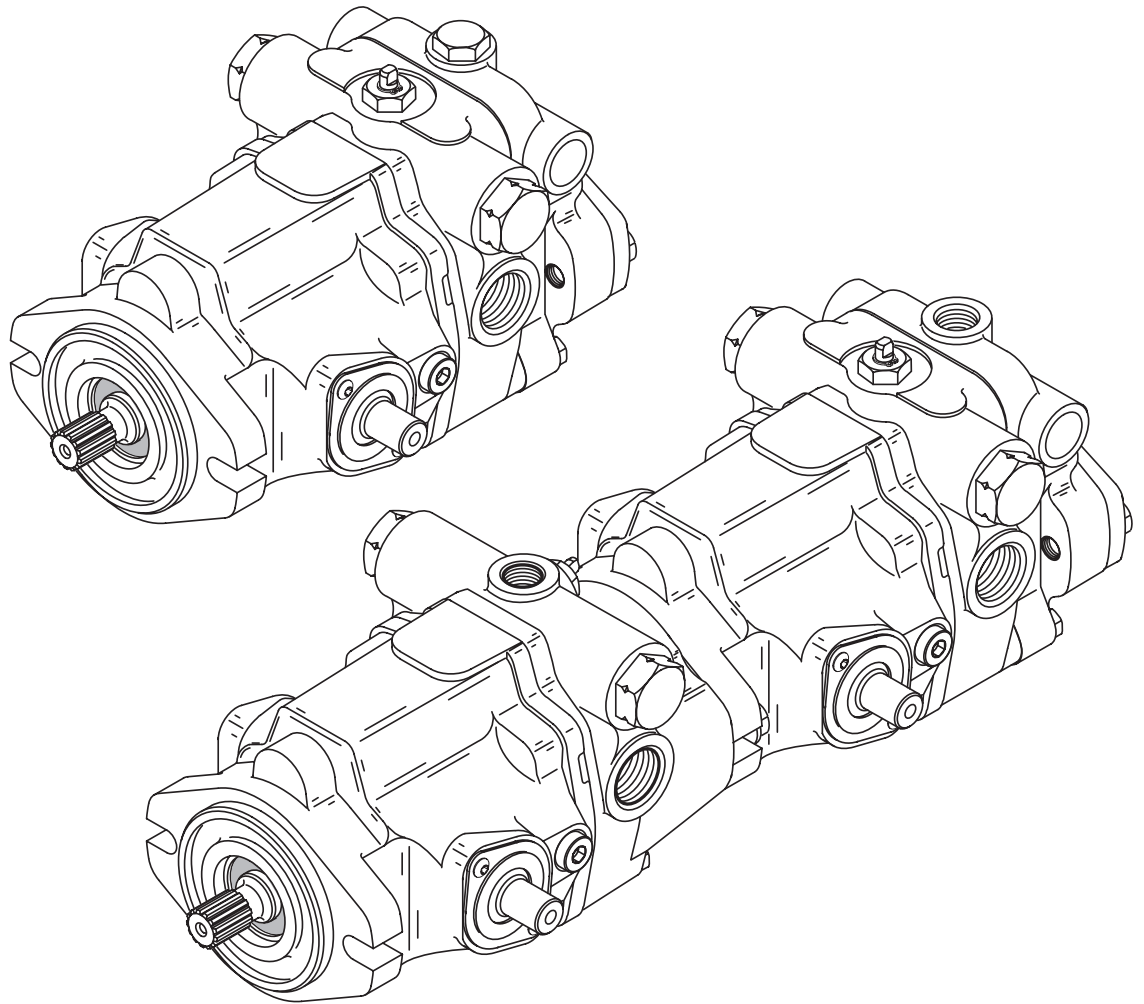

Model 70142 / 70144, 20.3 cm³/r [1.24 in³/r] Displacement
and 70145, 23.6 cm³/r [1.44 in³/r] Displacement

Variable Displacement Piston Pump

design code 01 & 02

with **Valve Plate**

Parts Drawing

Pump drawn below is typical of a righthand rotation pump.

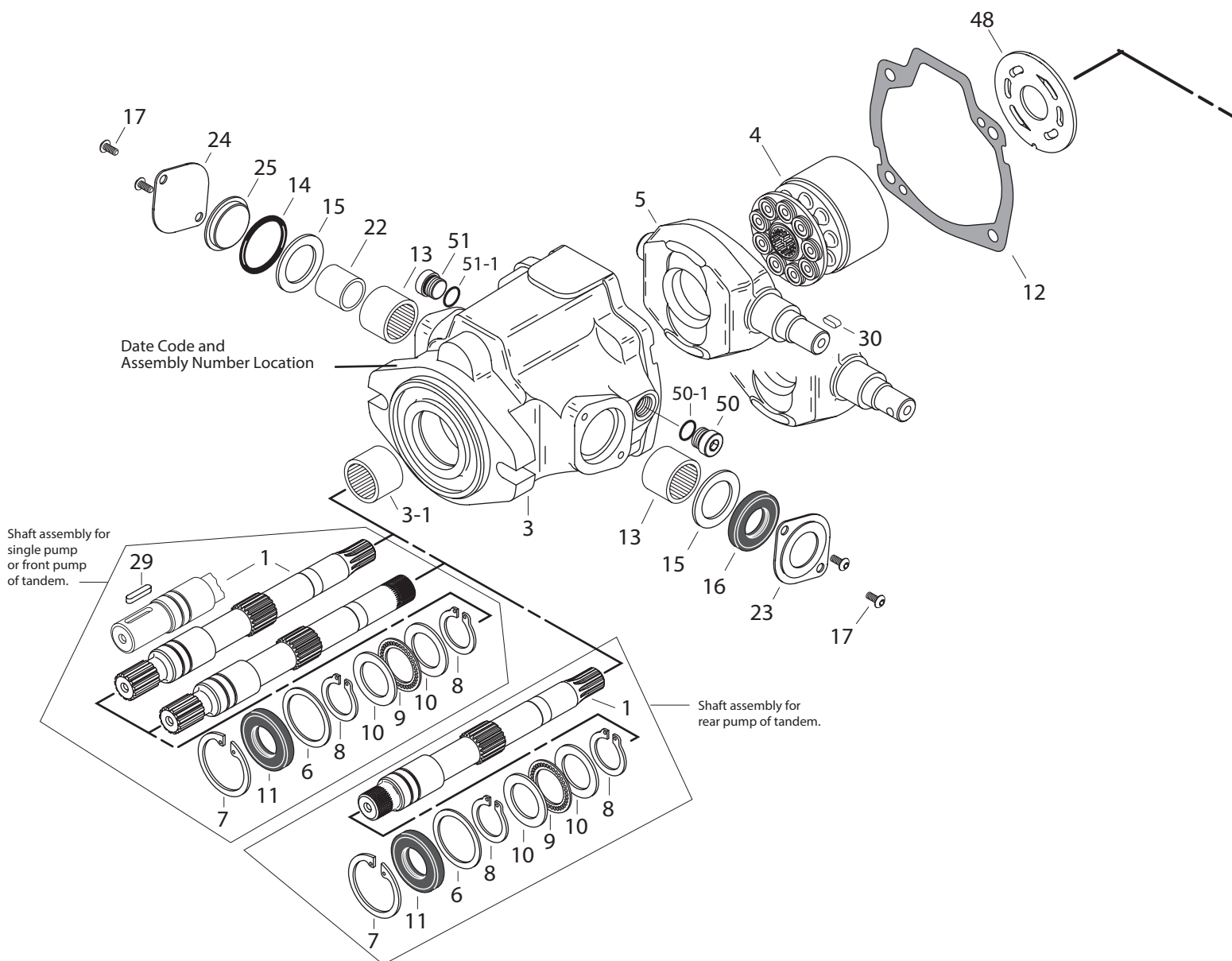

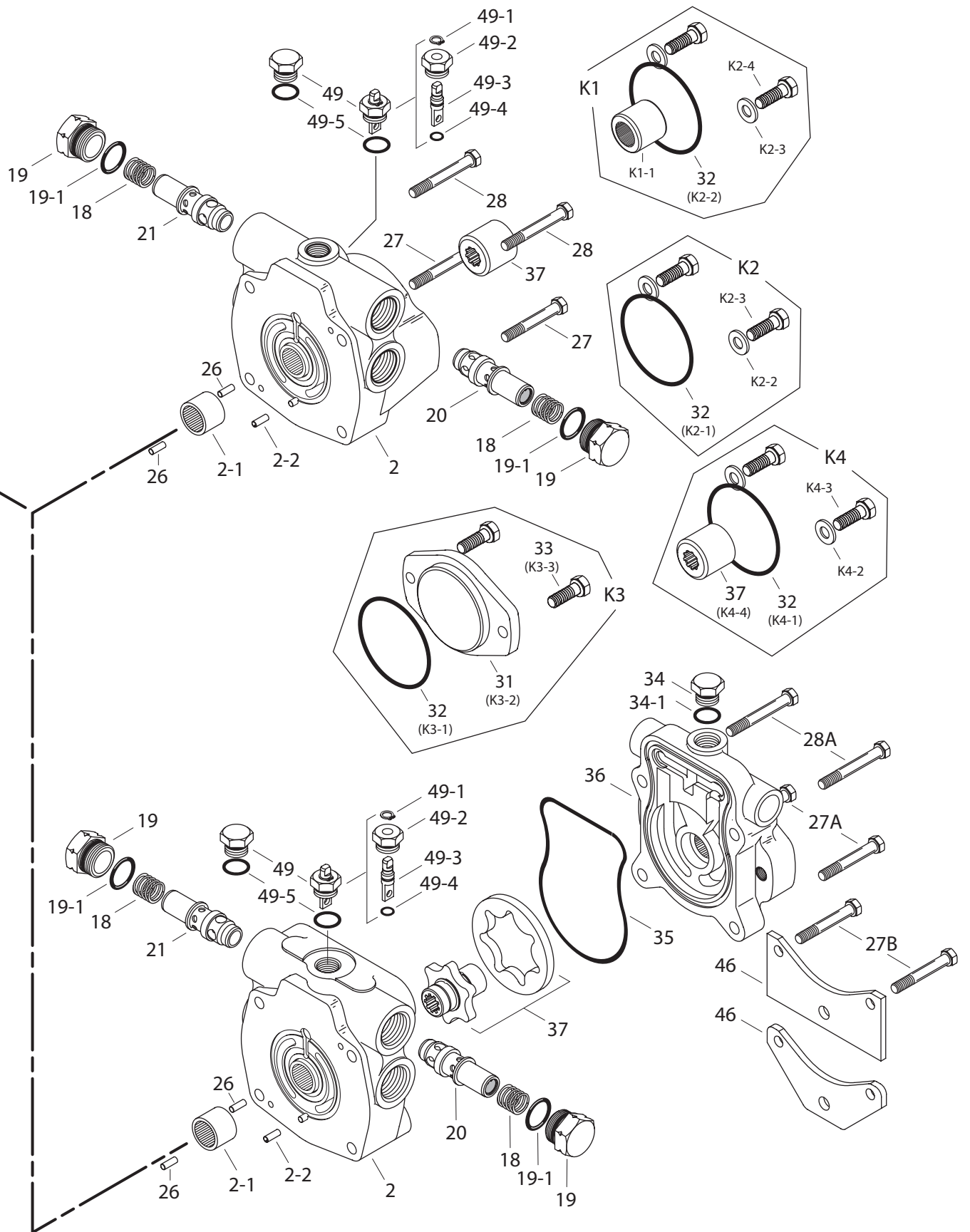

Parts List

Parts listed below are to service catalog units. Other variations of units are built that have parts altered for special requirements. The non-catalog units can be serviced with the parts list below using caution for proper identification. Contact a Danfoss representative with any questions concerning your selection. Have your final assembly number ready when contacting representative.

The following design code [02] part numbers are used to service both 01 and 02 catalog units with the exception of the item 48 valve plate. (See page 9 for details)

Item	02 Part No.	Qty.	Description
1		1	Drive Shaft (Identification drawing on page #6)
2		1	Backplate Assembly (Identification drawing and parts list on page #7)
3		1	Housing Assembly (Identification drawing on page #8)
4	70111-692	1	Rotating Kit Assembly (parts list on page #8)
5		1	Camplate, 20.3 cm ³ /r [1.24 in ³ /r] Displacement
	70111-665		Key groove in trunnion
	70111-702		Cross hole in trunnion
5		1	Camplate, 23.6 cm ³ /r [1.44 in ³ /r] Displacement
	70111-683		Key groove in trunnion
	70111-705		Cross hole in trunnion
6	16048-312	1	Washer
+ 7	16077-26	1	Retaining Ring
+ 8	16078-16	2	Retaining Ring
9	16241-1625	1	Thrust Bearing
10	16241-C1625	2	Bearing Race
+ 11	16253-16	1	Shaft Seal, Drive
11	16253-216	1	Viton Shaft Seal, Drive
+ 12	70111-701	1	Housing Gasket
13	76100-191	2	Needle Bearing
+ 14	16003-23	1	O-ring, 3.175 mm Dia. x 31.75 mm ID. [.125 in. Dia. x 1.25 in. ID.]
15	16048-534	2	Washer
+ 16	16253-214	1	Shaft Seal, Trunnion
17	16268-306	4	Screw, Pan Head
18	17079-2	2	Spring
19	32060-8	2	Plug Assembly
+ 19-1	16015-18-90	2	O-ring, 2.38 mm Dia. x 22.23 mm ID. [.0937 in. Dia. x .875 in. ID.]
20		1	Relief Valve for Port "C" (Identification drawing on page #9)
21		1	Relief Valve for Port "D" (Identification drawing on page #9)
22	70101-150	1	Inner Race
23	70102-615	1	Seal Cover
24	70102-616	1	Trunnion Cover
25	70102-625	1	Cover, O-ring
26	16028-304	2	Dowel Pin
27	16032-520	2	Cap Screws, 5/16-18, 50.8 mm [2 in.] Long
27A	16032-532	2	Cap Screws, 5/16-18, 82.6 mm [3.25 in.] Long
27B	16032-534	2	Cap Screws, 5/16-18, 88.9 mm [3.5 in.] Long
28	16032-524	2	Cap Screws, 5/16-18, 63.5 mm [2.5 in.] Long
28A	16032-536	2	Cap Screws, 5/16-18, 95.3 mm [3.75 in.] Long
29		1	Key, Drive Shaft
	24500-619		Used with 22.2 mm [.875 in] dia. drive shaft.
30	16246-425	1	Key, Camplate Trunnion
31	70142-600	1	Cover Plate (In K3 kit)
+ 32	16007-14	1	O-ring (In K1, K2, K3, & K4 kit)
33	16032-610	2	Cap Screws, Cover Plate (In K3 kit)
34	16103-108	1	Plug Assembly
+ 34-1	16133-8	1	O-ring, 2.21 mm Dia. x 16.36 mm ID. [.087 in. Dia. x .644 in. ID.]
+ 35	70111-703	1	Molded O-ring
36		1	Charge Pump Adaptor (Identification drawing and parts list on page #10 & #11)

Parts List

Item	02 Part No.	Qty.	Description
37	70111-642	1	Gerotor set and coupler sub-assembly 6.9 cm ³ /r [.42 in ³ /r] displacement, 6.35 mm [.25 in.] width
	70111-646		13.8 cm ³ /r [.84 in ³ /r] displacement, 12.7 mm [.5 in.] width
37	70111-667	1	9 tooth coupler (In Kit 4)
46	70111-632	1	Mounting Bracket, Square shaped
46	70111-709	1	Mounting Bracket, "V" shaped
48		1	Valve Plate (Identification drawing on page #9)
	70113-008		Righthand (CW) Rotation
	70113-009		Lefthand (CCW) Rotation
	70112-007		Low Cam Effort Valving, Righthand and Lefthand rotation
49	70411-503	1	Dump Valve sub-assembly
+ 49-1	16078-6	1	Retaining Ring
49-2	70411-501	1	Separator Plug
49-3	70411-502	1	Separator
+ 49-4	16003-7	1	O-ring, 1.59 mm Dia. x 9.53 mm I.D. [.0625 in. Dia. x .375 in. I.D.]
+ 49-5	16133-10	1	O-ring, 2.46 mm Dia. x 19.18 mm I.D. [.097 in. Dia. x .755 in. I.D.]
49	16169-1140	1	Plug Assembly
49-5	16133-10	1	O-ring, 2.46 mm Dia. x 19.18 mm I.D. [.097 in. Dia. x .755 in. I.D.]
50	16103-306	1	Plug Assembly
+ 50-1	16133-6	1	O-ring, 1.98 mm Dia. x 11.89 mm ID. [.078 in. Dia. x .468 in. ID.]
51	16103-306	1	Plug Assembly
+ 51-1	16133-6	1	O-ring, 1.98 mm Dia. x 11.89 mm ID. [.078 in. Dia. x .468 in. ID.]

Mounting Kits

K1	70142-944	1	Tandem Piston Pump Mounting Kit
K1-1	70111-666	1	35T Coupler, 36.8 mm [1.45 in.] long
K1-2	16007-14	1	O-ring, 1.59 mm Dia. x 101.6 mm ID. [.0625 in. Dia. x 4 in. ID.]
K1-3	16032-613	2	Cap Screws
K1-4	16048-8	2	Washer
K2	70442-929	1	Gear Pump Mounting Kit
K2-1	16007-14	1	O-ring, 1.59 mm Dia. x 82.55 mm ID. [.0625 in. Dia. x 3.25 in. ID.]
K2-2	16048-113	2	Washer
K2-3	16032-612	2	Cap Screws
K3	70142-915	1	Cover Plate Kit
K3-1	16007-14	1	O-ring, 1.59 mm Dia. x 82.55 mm ID. [.0625 in. Dia. x 3.25 in. ID.]
K3-2	70142-600	1	Cover Plate
K3-3	16032-610	2	Cap Screws
K4	70144-903	1	Gear Pump Mounting Kit with Coupler
K4-1	16007-14	1	O-ring, 1.59 mm Dia. x 101.6 mm ID. [.0625 in. Dia. x 4 in. ID.]
K4-2	16048-113	2	Washer
K4-3	16032-612	2	Cap Screws
K4-4	70111-667	1	9T Coupler

Seal Repair Kit

•	70142-938	1	Seal Repair Kit for 70142, 70144 and 70145 piston pump.
---	-----------	---	---

Legend

+ Refer to specific item parts list.
+ Included in seal repair kit.

Item 1 - Drive Shaft Identification

Part Number	Input Drive	Where Used	Output Drive
		Single Pump, with Gerotor	9 Tooth .81 Min. Full Depth
		Single Pump, with Gerotor	9 Tooth .81 Min. Full Depth
70142-200 [13 Tooth]		Single Pump, No Gerotor	9 Tooth .625 Min. Full Depth
70142-203 [7/8 in. Keyed]		Single Pump, No Gerotor	9 Tooth .625 Min. Full Depth
70142-215 [13 Tooth]		Tandem Front Pump, No Gerotor	35 Tooth .76 Min. Full Depth
70142-225 [7/8 in. Keyed]		Tandem Rear Pump, No Gerotor	9 Tooth .625 Min. Full Depth
70142-201 [13 Tooth]		Tandem Rear Pump, with Gerotor	9 Tooth .81 Min. Full Depth
70142-212 [35 Tooth] .69 Min. Full Depth			
70142-214 [35 Tooth] .69 Min. Full Depth			

Item 2 - Backplate Assembly Identification

Item 2 - Parts List (Refer to Identification chart and drawings)

Item	Part No.	Qty.	Description
2	See chart below		Backplate Assembly
2-1	70420-43	1	Bearing
2-2	16026-610	1	Roll Pin

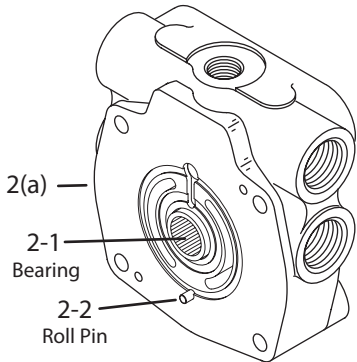

2(a)
Accepts
Gerotor Charge
Pump

design code
02

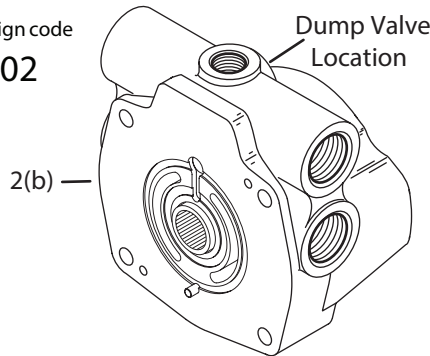

2(b)
Rear "A" Mount,
Opposite
Side Porting

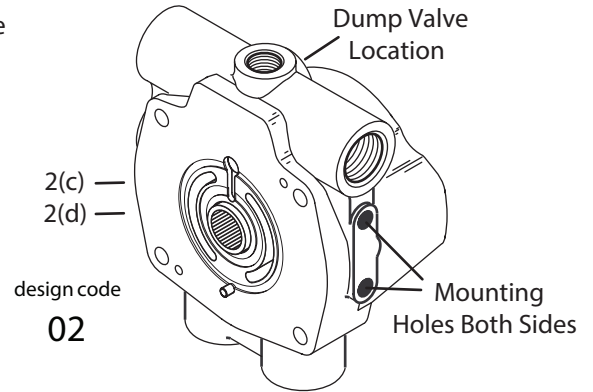

2(c)
Rear "A" Mount,
Same Side
Porting without
Mounting Holes

2(d)
Rear "A" Mount,
Same Side
Porting with
Mounting Holes

Item 2 - design code 02 numbers

Backplate Assembly Identification (Refer to drawings above)

Description	Assembly Part Number	Additional Description
2(a) - Accepts Gerotor Charge Pump	70119-001	
2(b) - Rear "A" Mount, Opposite Side Porting	70117-003	Dump Valve Port Machined in Bkpt./Assy.
	70117-004	No Dump Valve Port Machined in Bkpt./Assy.
2(c) - Rear "A" Mount, Same Side Porting without Mounting Holes	70121-003	No Dump Valve Port Machined in Bkpt./Assy.
	70121-006	Dump Valve Port Machined in Bkpt./Assy.
2(d) - Rear "A" Mount, Same Side Porting with Mounting Holes	70121-011	No Dump Valve Port Machined in Bkpt./Assy.
	70121-014	Dump Valve Port Machined in Bkpt./Assy.

design code

01

Identification

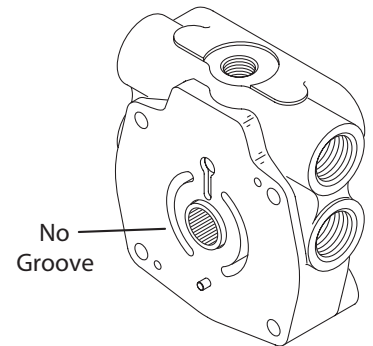

Item 3 - Housing Identification

Item 4 - Rotating Kit Assembly

Item 3 Housing Identification

Item	Part No.	Port Machined
3	70115-001	A
	70115-002	B
	70115-003	C
	70115-004	A, B
	70115-005	A, C
	70115-006	B, C
	70115-007	None
	70115-008	A, B, C
	70115-009	D

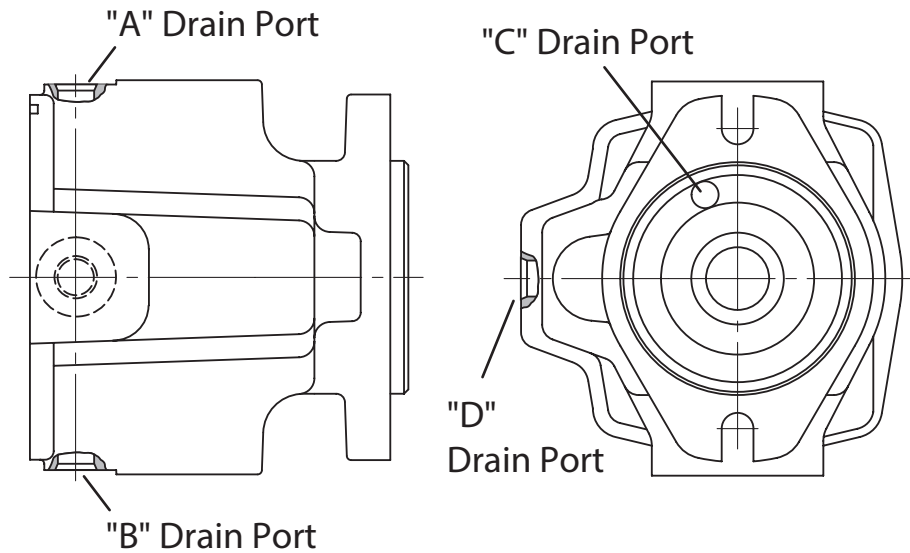

Drain Port Sizes:
 Drain Port A, B, and D are 9/16-18 SAE Str. Thd.
 Thru Drain Port C is 9.55[.376] dia.

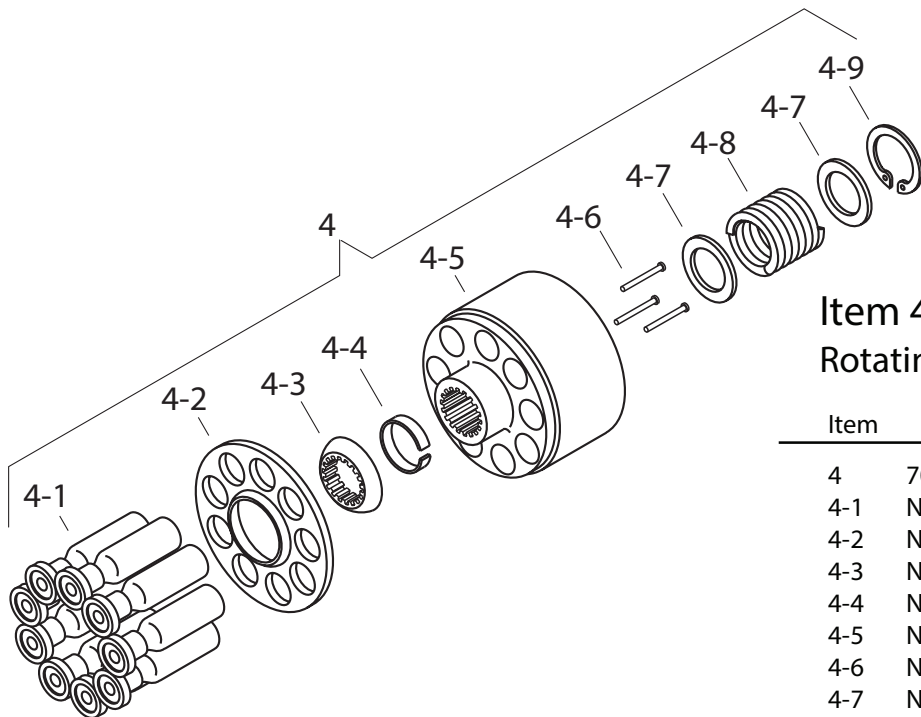

Item 4 Rotating Kit Assembly

Item	Part No.	Qty.	Description
4	70111-692	1	Rotating Kit Assy.
4-1	NSS	9	Piston Assembly
4-2	NSS	1	Spider
4-3	NSS	1	Spider Pivot
4-4	NSS	1	Retainer
4-5	NSS	1	Piston Block
4-6	NSS	3	Pins
4-7	NSS	2	Washer
4-8	NSS	1	Spring
4-9	NSS	1	Retaining Ring

NSS - Not Sold Separately

Item 20 or 21 - Relief Valve Item 48 - Valve Plate

Item 20 or 21 Internal Relief Valve Settings Available

Part Number	bar [lbf/in ²]
32060- LA	138 [2000]
32060- QA	172 [2500]
32060- UA	207 [3000]
32060- WA	241 [3500]
32060- ZA	276 [4000]
32060- XA	310 [4500]
32060- IA	345 [5000]
70111-518	Seat, Valve

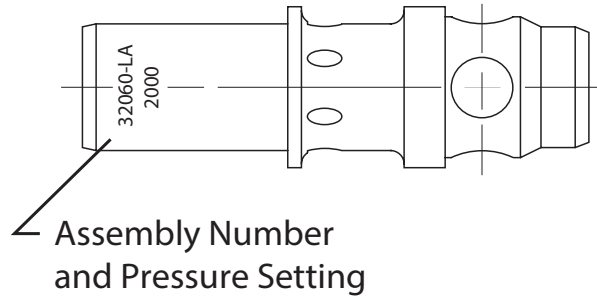

Item 48 Valve Plate Identification

Design Code 01

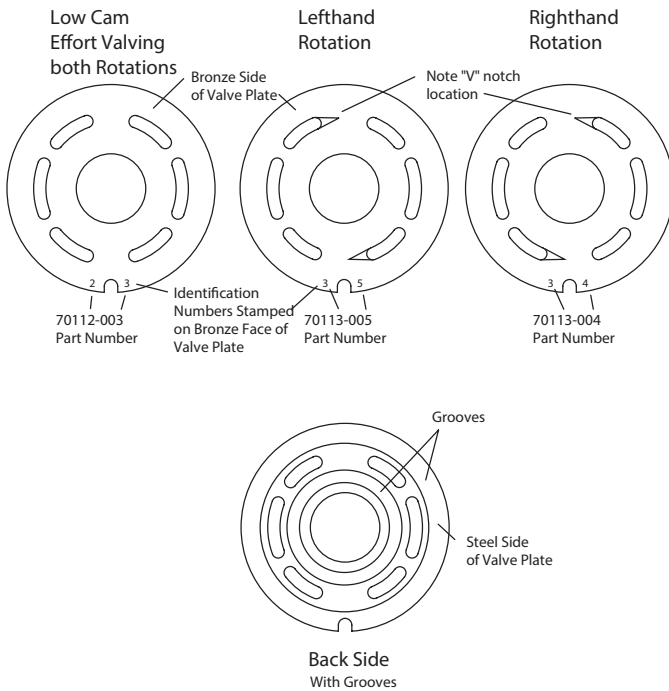

Design Code 02

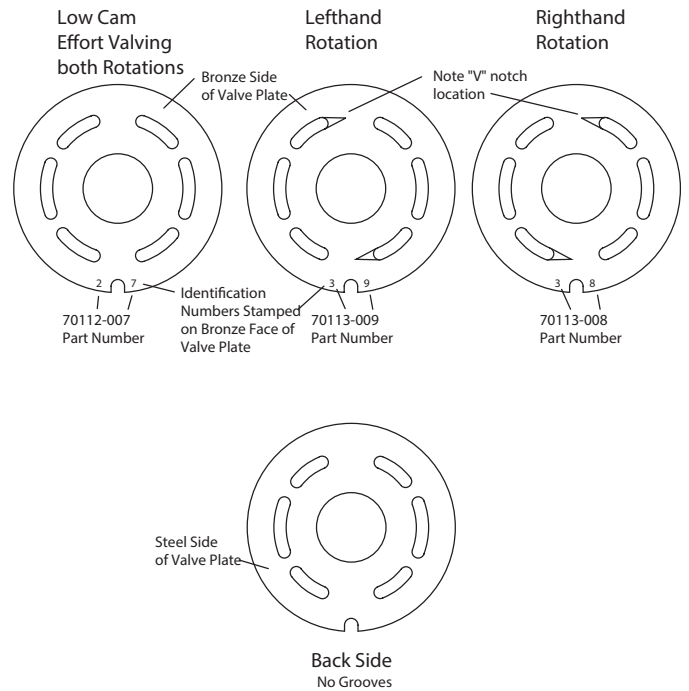

Note: The design code 01 valve plate must be used with the design code 01 backplates without grooves. The design code 01 valve plate may also be used with design code 02 backplate (See page 7 for backplate identification).

Item 36 - Charge Pump Adapter Assembly Identification

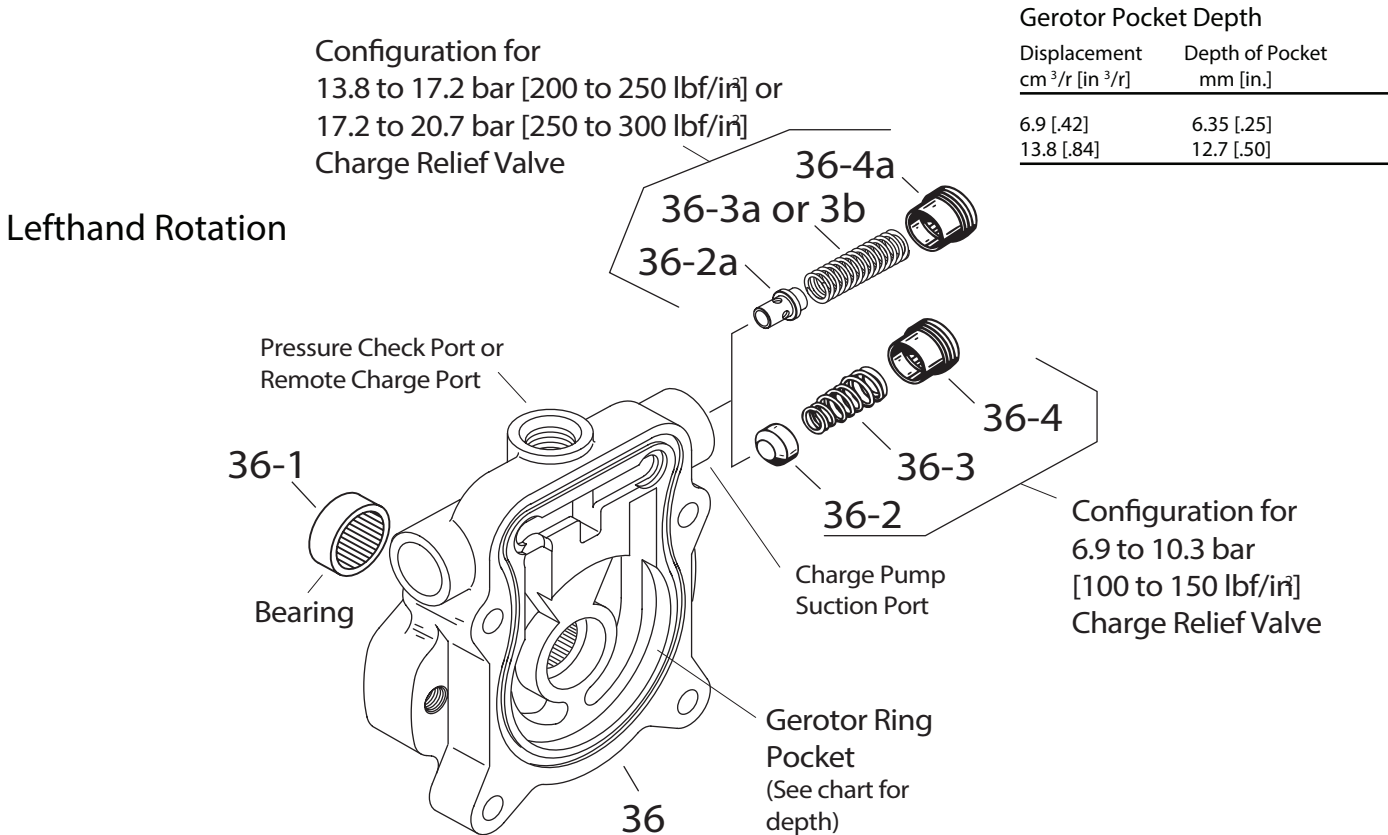
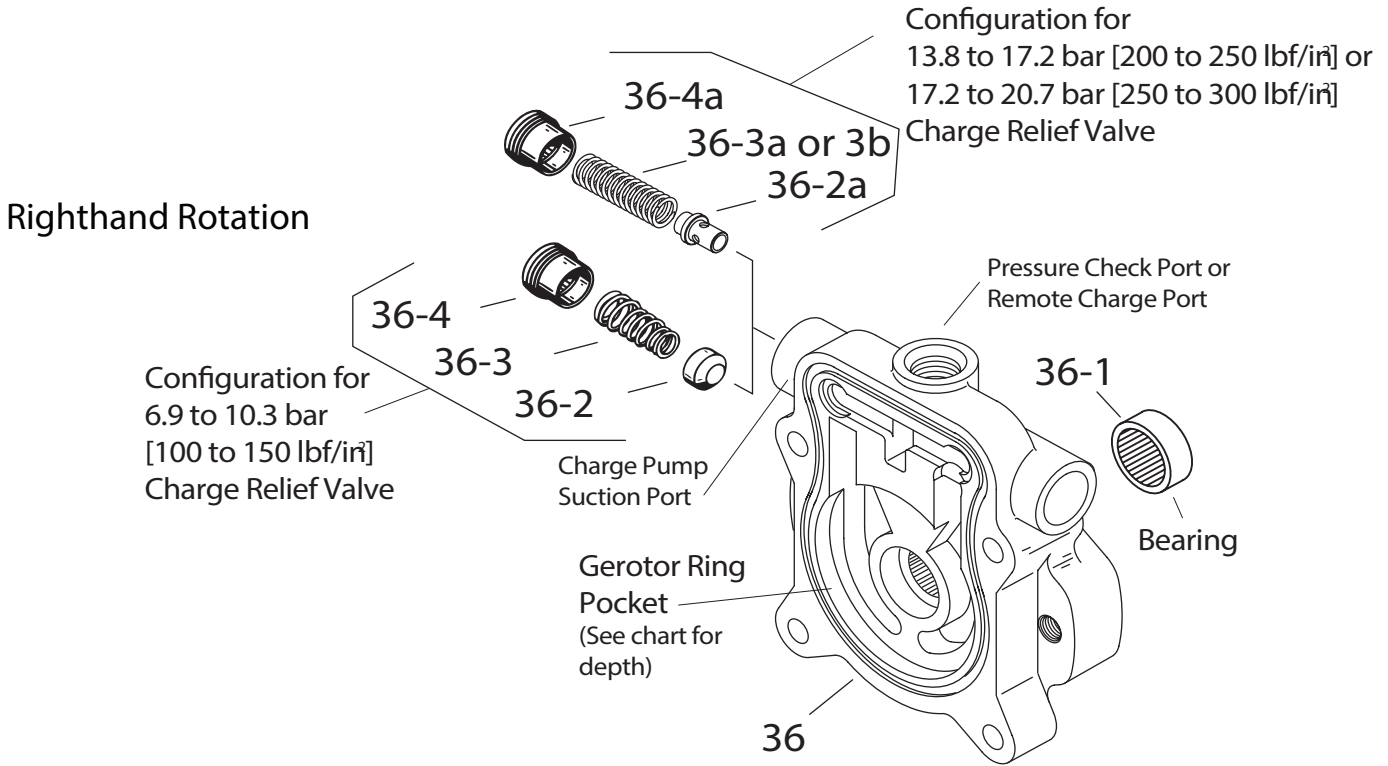

Gerotor Pocket Depth

Displacement cm ³ /r [in ³ /r]	Depth of Pocket mm [in.]
6.9 [.42]	6.35 [.25]
13.8 [.84]	12.7 [.50]

Item 36 - Charge Pump Adapter Assembly

6.9 to 10.3 bar [100 to 150 lbf/in²] Charge Relief Setting

Item	Part No.	Qty.	Description	Rotation	Displacement
36	70142-314	1	Assembly, Charge Pump Adapter	Righthand	6.88 cm^3 [.42 in ³ /r]
	70142-306	1	Assembly, Charge Pump Adapter	Lefthand	13.8 cm^3 [.84 in ³ /r]
	70141-397	1	Assembly, Charge Pump Adapter	Righthand	13.8 cm^3 [.84 in ³ /r]
	70142-359	1	Assembly, Charge Pump Adapter	Lefthand	6.88 cm^3 [.42 in ³ /r]
36-1	16239-1148	1	Bearing (press fit)		
36-2	70111-507	1	Poppet, Cup		
36-3	17000-48B	1	Spring, Tapered		
36-4	70400-505	1	Spring Retainer		

13.8 to 17.2 bar [200 to 250 lbf/in²] Charge Relief Setting

Item	Part No.	Qty.	Description	Rotation	Displacement
36	70142-373	1	Assembly, Charge Pump Adapter	Lefthand	6.88 cm^3 [.42 in ³ /r]
	70142-377	1	Assembly, Charge Pump Adapter	Righthand	6.88 cm^3 [.42 in ³ /r]
	70142-380	1	Assembly, Charge Pump Adapter	Righthand	13.8 cm^3 [.84 in ³ /r]
	70142-385	1	Assembly, Charge Pump Adapter	Lefthand	13.8 cm^3 [.84 in ³ /r]
36-1	16239-1148	1	Bearing (press fit)		
36-2a	70400-685	1	Poppet, Pin		
36-3a	17056-40	1	Spring, Color "Light Green"		
36-4a	70400-512	1	Spring Retainer		

17.2 to 20.7 bar [250 to 300 lbf/in²] Charge Relief Setting

Item	Part No.	Qty.	Description	Rotation	Displacement
36	70142-376	1	Assembly, Charge Pump Adapter	Righthand	6.88 cm^3 [.42 in ³ /r]
	70142-381	1	Assembly, Charge Pump Adapter	Lefthand	6.88 cm^3 [.42 in ³ /r]
	70142-386	1	Assembly, Charge Pump Adapter	Lefthand	13.8 cm^3 [.84 in ³ /r]
36-1	16239-1148	1	Bearing (press fit)		
36-2a	70400-685	1	Poppet, Pin		
36-3b	17056-41	1	Spring, Color "Pink"		
36-4a	70400-512	1	Spring Retainer		

Each order must include the following information.

1. Product and/or Part Number
2. Serial Number Code
3. Part Name
4. Quantity

Identification Numbers -Variable Displacement Piston Pump

Number is stamped on each units mounting flange.

A - Product Number Description

- 70142 = Piston Pump $\dot{Q}0.3 \text{ cm}^3/\text{r}$ [1.24 in³/r] with Gerotor
- 70144 = Piston Pump $\dot{Q}0.3 \text{ cm}^3/\text{r}$ [1.24 in³/r] without Gerotor
- 70145 = Piston Pump $\dot{Q}3.6 \text{ cm}^3/\text{r}$ [1.44 in³/r] with or without Gerotor
- 78113 = Tandem Piston Pumps $\dot{Q}0.3 \text{ cm}^3/\text{r}$ [1.24 in³/r] no Gear Pump
- 78114 = Tandem Piston Pumps $\dot{Q}0.3 \text{ cm}^3/\text{r}$ [1.24 in³/r] with Gear Pump
- 78115 = Tandem Piston Pumps $\dot{Q}3.6 \text{ cm}^3/\text{r}$ [1.44 in³/r] no Gear Pump
- 78116 = Tandem Piston Pumps $\dot{Q}3.6 \text{ cm}^3/\text{r}$ [1.44 in³/r] with Gear Pump

B - Rotation

- L = Lefthand
- R = Righthand

C - Sequential Lettering

D - Design Code Number

- 01 - valve plate design
- 02 - Change in valve plate & backplate.

Single Pump - Product Number:

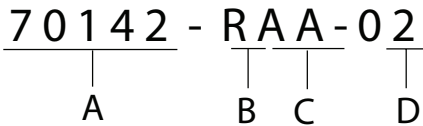

Tandem Pumps -Product Number:

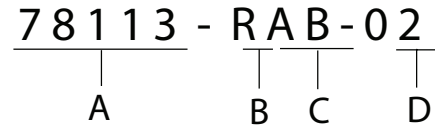

Serial Number Code:

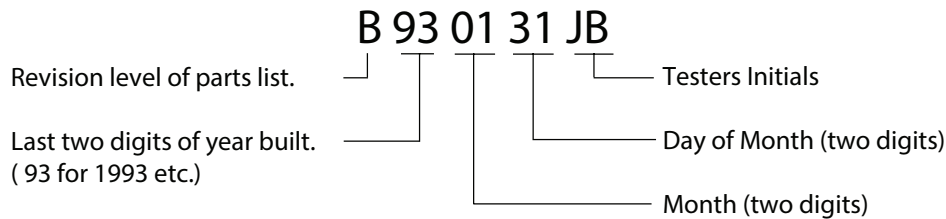

Products we offer:

- Cartridge valves
- DCV directional control valves
- Electric converters
- Electric machines
- Electric motors
- Gear motors
- Gear pumps
- Hydraulic integrated circuits (HICs)
- Hydrostatic motors
- Hydrostatic pumps
- Orbital motors
- PLUS+1® controllers
- PLUS+1® displays
- PLUS+1® joysticks and pedals
- PLUS+1® operator interfaces
- PLUS+1® sensors
- PLUS+1® software
- PLUS+1® software services, support and training
- Position controls and sensors
- PVG proportional valves
- Steering components and systems
- Telematics

Danfoss Power Solutions is a global manufacturer and supplier of high-quality hydraulic and electric components. We specialize in providing state-of-the-art technology and solutions that excel in the harsh operating conditions of the mobile off-highway market as well as the marine sector. Building on our extensive applications expertise, we work closely with you to ensure exceptional performance for a broad range of applications. We help you and other customers around the world speed up system development, reduce costs and bring vehicles and vessels to market faster.

Danfoss Power Solutions – your strongest partner in mobile hydraulics and mobile electrification.

Go to www.danfoss.com for further product information.

We offer you expert worldwide support for ensuring the best possible solutions for outstanding performance. And with an extensive network of Global Service Partners, we also provide you with comprehensive global service for all of our components.

Local address:

Hydro-Gear

www.hydro-gear.com

Daikin-Sauer-Danfoss

www.daikin-sauer-danfoss.com

**Danfoss
Power Solutions (US) Company**
2800 East 13th Street
Ames, IA 50010, USA
Phone: +1 515 239 6000

**Danfoss
Power Solutions GmbH & Co. OHG**
Krokamp 35
D-24539 Neumünster, Germany
Phone: +49 4321 871 0

**Danfoss
Power Solutions ApS**
Nordborgvej 81
DK-6430 Nordborg, Denmark
Phone: +45 7488 2222

**Danfoss
Power Solutions Trading
(Shanghai) Co., Ltd.**
Building #22, No. 1000 Jin Hai Rd
Jin Qiao, Pudong New District
Shanghai, China 201206
Phone: +86 21 2080 6201