

EATON

Vickers

V20D

Technical Focus

DG Ready Vane Pump

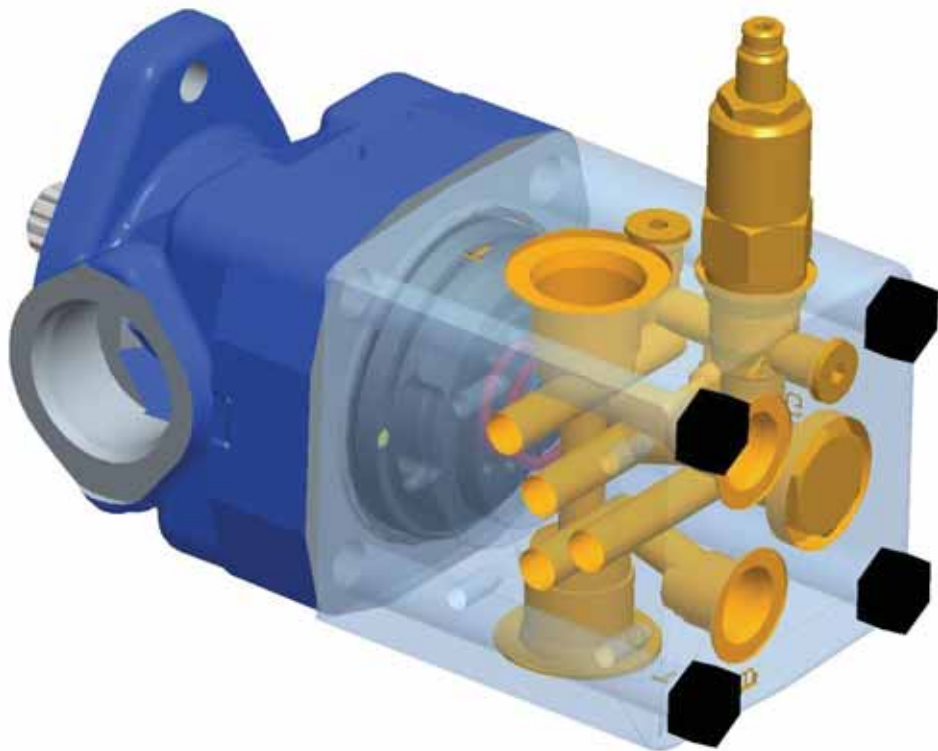

Introduction

V20D Vane Pumps

Compact

Simple

Flexible

Reliable

Durable

Cost Savings

DG Ready

Features

- Four cover orientations, two choices of tank ports
- Less leakage points
- Durable cast-iron structure
- Space saving – only 2.8 inch longer than standard pump
- Popular standard cartridge valves
- Modular pump design

Benefits

- Quiet, reliable, long life and consistent high performance overlife
- Cost savings
- Installation labor savings
- No need for sub-plate for valve mount
- Eliminate hose/pipe connection between pump and valves
- Easy maintenance/repair
- Flexible installation



Standard V20 Vane Pump

Displacement: 16 – 42cc

SAE A & B mount

NPT, Straight Tread, and
2 Bolt Ports

Key, Spline, Key Thread and
Woodruff Shafts

Special Pump Cover Block

D03 and D05 DG Valve
Interface

Screw-in Cartridge Relief Valve

Optional Check Valve

Gauge Ports

V20D Cover Block

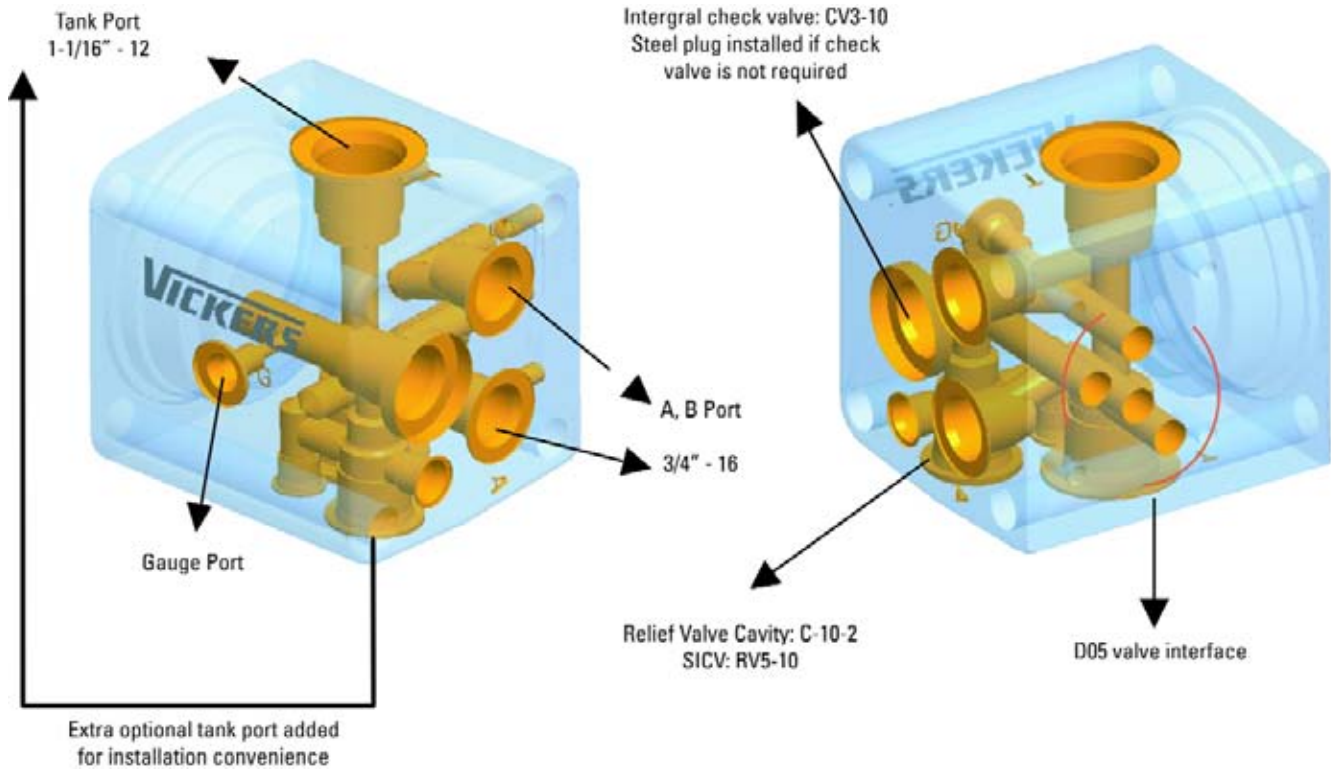

Cover Block - Circuitry

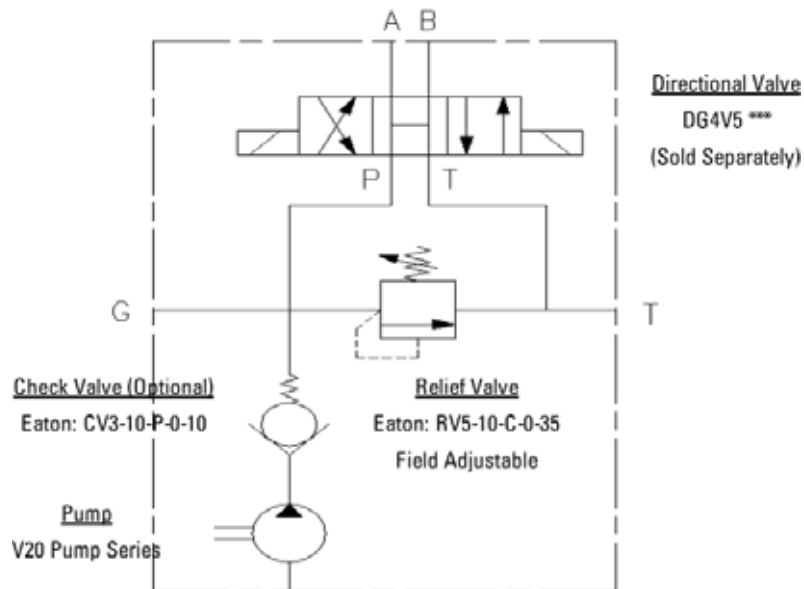

Model Codes

V20D Pump

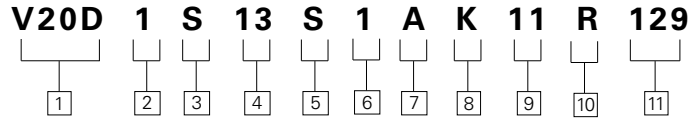

1 Pump Name

2 Pump Mount

- 1** – SAE A mount
- 6** – SAE B mount

3 Inlet Port

- S** – 1-5/8"–12
- P** – 1-1/4" NPT thread
- E** – 1-1/2" 2 bolt flange
- B** – G (BSP) 1-1/4"

4 Flow

- 13** – US gpm (1200 rpm & 100psi) 5, 6,7,8,9,11,12,13

5 Outlet Port

- S** – SAE O ring port (J514)
A, B port: 3/4" – 16
Tank port: 1-1/16" – 12
Gauge port: 7/16 – 20

6 Shaft

- 1** – Key
- 62** – Spline 9T
- 38** – Spline 11T
- 39** – Spline 13T
- 3** – Key tread
- 22** – Woodruff

**7 Cover position
(View from cover end)**

- A** – DG interface opposite of inlet
- B** – DG interface 90° CCW from inlet
- C** – DG interface in line with inlet
- D** – DG interface 90° CW from inlet

8 Relief Valve Setting

- | | |
|--------------------|--------------------|
| A – 250psi | G – 1750psi |
| B – 500psi | H – 2000psi |
| C – 750psi | J – 2250psi |
| D – 1000psi | K – 2500psi |
| E – 1250psi | L – 2750psi |
| F – 1500psi | M – 3000psi |

9 Design code

**10 Rotation
(View from shaft end)**

- L** – Left hand
- R** – Right hand

11 Suffix

- 129** – D05 w/o check
- 130** – D05 w/ check
- 136** – D03 w/o check
- 137** – D03 w/ check

Basic Dimensions

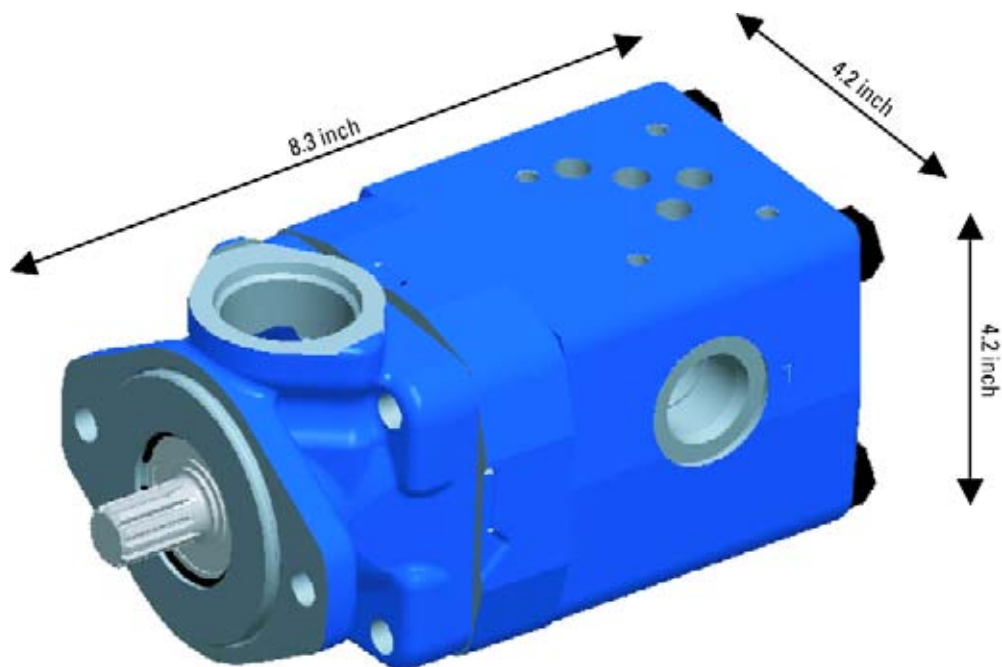

Why Use Vane Pumps?

Design Benefits

Flexible Displacement Change

- Easy repair or reconfiguration

Ball Bearing

- Long life

Hydraulic Balanced Design

- No shaft fatigue caused by side load

Low pressure ripple

- Quiet operation

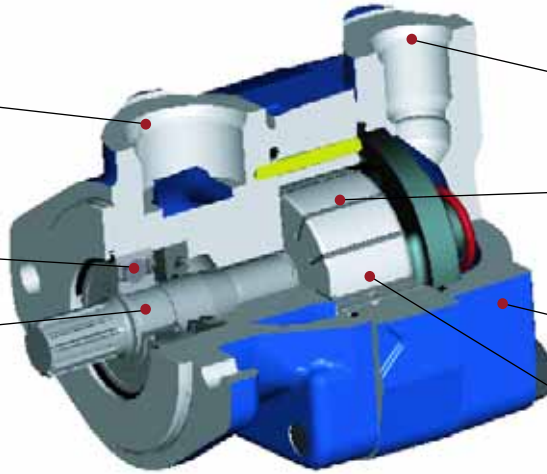

Flexible Porting

- Easy installation

Vane Self-wear Compensation

- No performance degradation over life

Cast Iron Structure

- Durable

Floating Rotor

- Less chance of side plate smearing

Ring profile generates smooth pressure transition for the oil trapped between the adjacent two vanes

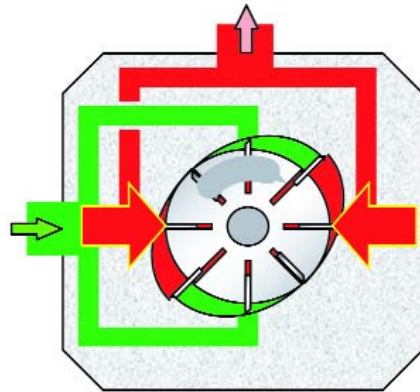

Pressure balanced rotor

Vickers Vane Pump Family

Reliable, Quiet, Compact, Long Life

Economical

V10/V20 Square

- 3000psi [210 Bar]
- 0.2in³ [3.3cc] - 2.59in³ [42cc]
- Single, Double Pumps
- Optional integral valves

Comprehensive

V/VQ(H)

- Up to 3500 psi [240 Bar]
- 1.1in³ [18cc] – 20.9in³ [343cc]
- Cartridge-kit Design
- Industrial V and Mobile VQ(H)
- Single, Double and Thru-Drive Pumps

Tough

VMQ

- Up to 4250psi [280 Bar]
- 0.6in³ [10cc] – 13.1in³ [215cc]
- Cartridge-kit Design
- Bi-metal wafer plate
- Single, Double and Thru-Drive Pumps



Eaton
14615 Lone Oak Road
Eden Prairie, MN 55344
USA
Tel: 952 937-9800
Fax: 952 974-7722
www.hydraulics.eaton.com

Eaton
20 Rosamond Road
Footscray
Victoria 3011
Australia
Tel: (61) 3 9319 8222
Fax: (61) 3 9318 5714

Eaton
Dr.-Reckeweg-Str. 1
D-76532 Baden-Baden
Germany
Tel: (49) 7221 682-0
Fax: (49) 7221 682-788

