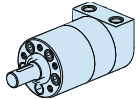
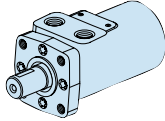
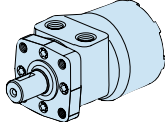
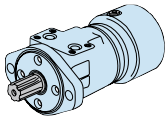
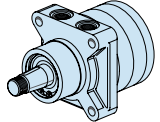
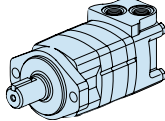
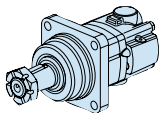
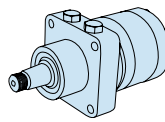
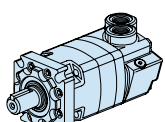
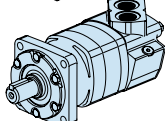
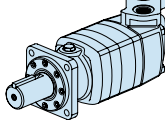
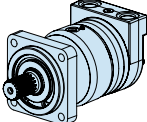
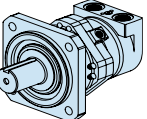

Contents

	SECTION	PRODUCT NUMBER PREFIX	PAGE	
	Introduction to Eaton Motors		A-3	A
	J Series	(129-)	B-1-1	B-1
	H Series	(101-)	B-2-1	B-2
	S Series	(103-)	B-3-1	B-3
	T Series & "T" Series w/Parking Brake	(158-) (185-)	B-4-1	B-4
	W Series & W Series w/Parking Brake	(162-)	B-5-1	B-5
	2000 Series	(104-, 105-, 106-, 193-)	C-1-1	C-1
	4000 Compact Series	(167-, 169-, 170-)	C-2-1	C-2
	Delta Series	(184-)	C-3-1	C-3
	4000 Series	(109-, 110-, 111-)	C-4-1	C-4
	6000 Series	(112-, 113-, 114-)	C-5-1	C-5
	10,000 Series	(119-, 120-, 121-)	C-6-1	C-6
	VIS 40 & VIS 40 w/Parking Brake	(168-, 176-, 177-, 178-, 180-, 182-)	D-1-1	D-1
	VIS 45	(155-, 156-, 157-, 173-, 174-, 183-)	D-2-1	D-2

Contents

Char-Lynn, Hydraulic Motors	A-3
Circuits	A-4
Design Flexibility	A-5
Motor Application Information	A-6
Optional Features	A-8
Two Speed Motors	A-11
Seal Guard	A-12
Viton Seals	A-12
High Pressure Seals	A-13
Braking Solution	A-14
Free Running Geroler Sets/Gerotor Sets	A-15
Speed Sensors	A-16
Shuttle Valve	A-17
Case Porting	A-18
Low Speed Valving	A-19
Nickle Plating Option	A-20
Integral Valves for 2000 Series	A-21
Bolt-On Valve Solutions for Char-Lynn Motors	A-22
Overcenter Packages for H&T Series Motors	A-23
Overcenter Packages (w/shuttle) for H&T Series Motors	A-25
Cross-Over Relief Packages for H&T Series Motors	A-27
Overcenter Packages for 2000 Series Motors	A-28
Overcenter Packages (w/shuttle) for 2000 Series Motors	A-30
Cross-Over Relief Packages for 2000 Series Motors	A-32
ATEX Certification	A-33
Fluid Recommendations	A-34

Introduction

For the past 45 years, the Char-Lynn®, brand has been recognized as the industry leader in low-speed, high-torque (LSHT) hydraulic motor technology. The name Char-Lynn was coined by one of the original pioneers in the hydraulic industry, the late Mr. Lynn Charlson. The hydraulic motor designs developed by Lynn Charlson and his team use what is termed as the Orbit principle. This principal is the center of the designs pioneered by the Char-Lynn team and is based on the fact that a gerotor or Geroler®, star orbits multiple times (typically 6 to 8 times depending on specific star and ring geometry) for each complete single revolution within the outer ring. This principle is what gives Char-Lynn motors their reliable high power density and extremely compact size. Only three primary moving components are needed to transmit torque through the motor: star, drive and output shaft. Shaft rotation can be instantly reversed by changing inlet / outlet flow while generating equal torque in either direction. A variety of displacement sizes are available in each motor family that provide a wide variety of speeds and torque ranges from any series of motors. The results are compact, modular, economical designs that can be easily customized to suit a wide variety of application needs.

Motor options include:

- Displacement size (cubic inches or cc's per revolution)
- Output shaft size and type
- Mounting flange type
- Porting interface
- A wide selection of special features such as integrated brakes, sensors, integrated cross-over relief valves, 2-speed capability, manifold valve packages, and environmental protection suited for corrosive environments.

Char-Lynn motors are extremely reliable, compact, and have tremendous power density. They provide a way to meet many needs for cost-effective power transmission requirements. Multiple motors can be driven by a single power source (pump) and controlled using a wide array of valves and variable displacement pump controls. Motors can even be configured with electronic sensors to provide digital feedback for sensing both motor direction and

output speed.

The Char-Lynn motor range consists of three major types based on the type of valving used to distribute fluid through the Orbit gear set (geroler or gerotor). These three types are:

- **Spool Valve**
- **Disc Valve**
- **VIS (Valve-in-Star)**

Migration from one valve technology to the next enhances motor performance in terms of efficiency, pressure rating, displacements, and motor output torque capability.

To help guide you to proper product selection, a quick guide is provided below. In addition, you will find product highlights, summaries of motor option features and benefits, application formulas, and detailed specifications for each motor family.

MOTOR QUICK-GUIDE (BASED ON MAXIMUM CONTINUOUS RATINGS)

Type	Output Torque Nm [lb-in]	Pressure bar [psi]	Flow lpm [gpm]	Side Load kg [lbs]
Spool Valve	441 [3905]	165 [2400]	62 [18]	725 [1600]
Disc Valve	2700 [24000]	205 [3000]	170 [45]	4500 [10000]
VIS (valve-in-star)	4520 [40000]	345 [5000]	170 [45]	8640 [19000]

Circuits

Circuit Design Considerations

Hydraulic Circuit

Hydraulic drives can be divided into two basic types: 1) Traction Drives and 2) Non-Traction drives. Traction drives (also referred to as propel drives) are used to propel a wheeled or track-driven vehicle. Non-traction drives (also referred to as work drives) are used for some other vehicle function such as a winch, auger, conveyor or rotate function for a boom or crane.

These rotary drive systems can also be classified as either open loop or closed-loop circuits.

Open Loop Circuit

In an open loop circuit, oil is returned to a reservoir before returning to the motor. The motor/pump circuit is open to atmosphere. In an open loop circuit, the drive speed of a motor may be controlled by, varying the flow with a valve, changing pump input speed (engine or pump input speed), or varying flow using a variable displacement pump. Often these circuits use counter-balance valves to accomplish dynamic braking functions, and provide a flow (pressure) source to release a spring-applied, hydraulic release brake. It is common to use a shuttle valve for directing flow to release the spring-applied pressure-release brake. A shuttle valve is basically a double check valve that directs flow from the A or B side of the loop and is often the source of flow to create the pressure to release a brake.

Typical applications using open loop circuits include:

- Truck-Mounted Booms and cranes (boom – rotate function)
- Aerial Work Platforms (boom – rotate function)
- Winches
- Conveyors
- Grapples
- Others

Closed Loop Circuit

In a closed loop circuit, there is no reservoir between the inlet and outlet of the motor and pump. The pump outlet is connected directly to the motor inlet and the motor outlet is connected directly to the pump inlet. This circuit is, in theory, closed to atmosphere. Motor speed is typically controlled using a variable displacement pump. This pump can also control motor output shaft direction (CW or CCW rotation).

These systems provide dynamic control of flow through the closed loop of the motor/pump circuit. They are, however, subject to some inherent internal leakage that results in the inability of the loop to hold a load over time. This is why a static brake is typically found in such systems to mechanically hold the load. Brakes used include mechanical caliper, disc or ball-ramp type brakes. In addition, spring-applied, hydraulic release brakes are used. The T Series Motor w/ Parking Brake meets this need.

Typical applications using closed loop circuits include:

- Vehicle traction drives (propel function)
- Conveyors
- Winches
- Others

Char-Lynn motors are truly built for high torque low speed. A lot of power is derived from this small package. This power advantage provides the designer with a product that can be used for overall compactness in addition to taking full advantage of the high pressure ratings typical of present day hydraulic components.

Char-Lynn hydraulic motors allow the designer to put the power where it is needed. Furthermore, the motors can be mounted directly on the driven device away from the original power source which eliminates the need for other mechanical linkages such as chains, sprockets, belts, pulleys, gears, rotating drive shafts, and universal joints. Several motors can be driven from the same power source and can be connected in series or parallel to each other.

Case Drain and Shuttle Valve Options

Many hydraulic systems can benefit from the use of a system case drain. Char-Lynn motors provide this feature built in. One

Durability

The design and method of manufacture of three critical drive train components: valve drive, shaft drive, and output shaft, give these motors durability. Consequently, the motors stand up against high hydraulic pressures.

Performance Rating

Our method of rating these motors recognizes that at slower speeds and flow, higher pressures and torque are permitted. Hence, our performance data shows the complete flow range (down to 1 liter per minute or 1/4 gallon per minute) and speed range (down to one revolution per minute depending on application).

Controllable Speeds

Char-Lynn motors operate at low speeds that remain very near constant even when load varies. Shaft speed is varied smoothly, easily and economically using simple inexpensive controls. Also, these motors are reversible. Consequently, direction of shaft rotation can be changed instantly with equal output torque in either direction.

Dependable Performance

Highly precise manufacturing of parts provide consistent, dependable performance and long life even under varying conditions.

Reliability

Char-Lynn motors are self contained, with hydraulic fluid providing lubrication. These motors are completely sealed so they can operate safely and reliably in hostile environments such as dust, dirt, steam, water, and heat and provide reliable performance.

High Efficiencies

Char-Lynn motors efficiently convert the supplied hydraulic fluid's pressure and flow into a low speed high torque rotational output. This efficiency minimizes the rate of hydraulic system heat generation and maximizes shaft horsepower.

of the advantages for case drain flow is that contamination is flushed from the system. This flushing also aids in cooling the system and lowering the case pressure which will

extend motor seal life. With a case drain line in place, oil pressure in the gear box (Bearingless motor applications) can also be controlled. In applications where more system cooling

and flushing is required, a shuttle valve option is available in W series, 2000, 4000 Compact, 4000, 6000 series, VIS 30, VIS 40 and VIS 45 series motors.

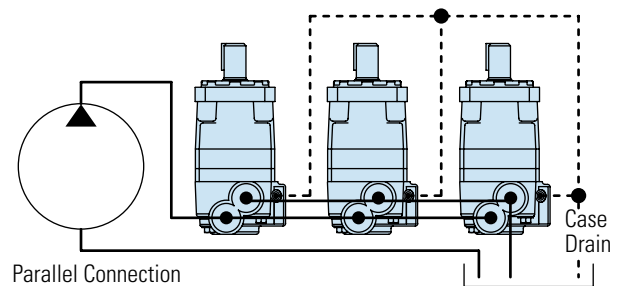
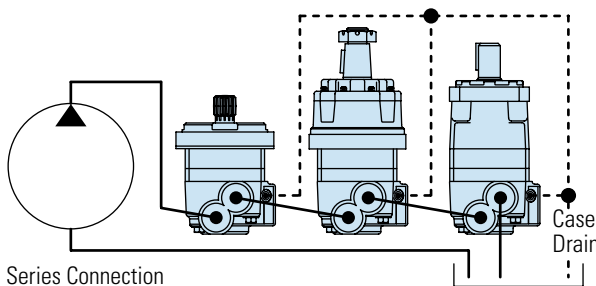

Motor Application Information

Vehicle Drive Calculations

Step One – Calculate Motor Speed (RPM)

$$\text{RPM} = \frac{2.65 \times \text{KPH} \times G}{R_m} \quad \text{RPM} = \frac{168 \times \text{MPH} \times G}{R_i}$$

where KPH = vehicle speed (kilometers per hour)

where MPH = vehicle speed (miles per hour)

R_m = rolling radius of tires (meter)

R_i = rolling radius of tires (inch)

G = gear reduction ratio (if any) between motors and wheels. If no gear box or other gear reduction devices are used G = 1.

If vehicle speed is expressed in m/second, multiply by 3.6 to convert to KPH. If vehicle speed is expressed in ft./second, divide by 1.47 to convert to MPH.

Step Two – Determine Rolling Resistance

Rolling resistance (RR) is the force required to propel a vehicle over a particular surface. The values in Table 1 are typical of various surfaces per 1000 lb. of vehicle weight.

$$\text{RR} = \text{GVW} \times \rho \text{ (kg) (lb)}$$

where GVW = gross (loaded) vehicle weight lb/Kg

ρ = value from Table 1

TABLE 1- ROLLING RESISTANCE COEFFICIENTS FOR RUBBER TIRES ON VARIOUS SURFACES

Surface	r
Concrete, excellent	.010
Concrete, good	.015
Concrete, poor	.020
Asphalt, good	.012
Asphalt, fair	.017
Asphalt, poor	.022
Macadam, good	.015
Macadam, fair	.022
Macadam, poor	.037
Snow, 2 inch	.025
Snow, 4 inch	.037
Dirt, smooth	.025
Dirt, sandy	.040
Mud	.037 to .150
Sand, Gravel	.060 to .150
Sand, loose	.160 to .300

Step Three – Tractive Effort to Ascend Grade

The largest grade a vehicle can ascend is called its "gradability." Grade is usually expressed as a percent rather than in degrees. A rise of one meter in ten meters or one footrise in ten feet of travel is a 1/10 or 10 percent grade.

$$\text{GR} = \text{GVW} (\sin \theta + \rho \cos \theta)$$

TABLE 2

Comparison Grade (%)	Table Slope (Degrees)
1%	0° 35'
2%	1° 9'
5%	2° 51'
6%	3° 26'
8%	4° 35'
10%	5° 43'
12%	6° 5'
15%	8° 31'
20%	11° 19'
25%	14° 3'
32%	18°
60%	31°

Step Four – Determine Acceleration Force (FA)

The force (FA) required to accelerate from stop to maximum speed (KPH) or (MPH) in time (t) seconds can be obtained from the following equation:

$$\text{FA} = \frac{\text{KPH} \times \text{GVW}(\text{kg})}{3.6 t}$$

FA = Acceleration Force (Newton)
t = Time (Seconds)

$$\text{FA} = \frac{\text{MPH} \times \text{GVW} (\text{lb})}{22 t}$$

FA = Acceleration Force (lb)
t = Time (Seconds)

Step Five – Determine Drawbar Pull

Drawbar Pull (DP) is total force available at the drawbar or "hitch" after the above forces have been subtracted from the total propelling force produced by the hydraulic motors. This value is established as either:

1. A goal or objective of the designer.
2. A force required to pull a trailer (Repeat steps two through four above using trailer weight and add the three forces together to obtain DP).

Motor Application Information

Vehicle Drive Calculations

Step Six – Total Tractive Effort

The tractive effort (TE) is the total force required to propel the vehicle and is the sum of the forces determined in Steps 2 through 5.

$$TE = RR + GR + FA + DP \text{ (Kg. or lb.)}$$

\swarrow \swarrow \swarrow \swarrow
 Force required to overcome rolling resistance Force required to climb a grade Force required to accelerate Drawbar pull desired

Wind resistance forces can usually be neglected. However, it may be wise to add 10% to the above total to allow for starting resistances caused by friction in bearings and other mechanical components.

Step Seven – Calculate Hydraulic Motor Torque (T)

$$T = \frac{TE \times R_m}{N \times G \times E_g} \text{ (Nm / Motor)}$$

$$T = \frac{TE \times R_l}{N \times G \times E_g} \text{ (lb - in/Motor)}$$

Where: N = number of driving motors
Eg = gear box mechanical efficiency

Step Eight—Wheel Slip

If the torque required to slip the wheel (TS) is less than the torque calculated in Step 7, the performance objectives cannot be achieved.

$$TS = \frac{W \times f \times R_m}{G \times E_g} \text{ (Nm / Motor)}$$

$$TS = \frac{W \times f \times R_l}{G \times E_g} \text{ (lb - in/Motor)}$$

Where: f = coefficient of friction
W = loaded vehicle weight over drive wheel

	Coefficient of friction (f)
Steel on steel	0.15 to 0.20
Rubber tire on dirt	0.5 to 0.7
Rubber tire on asphalt	0.8 to 1.0
Rubber tire on concrete	0.8 to 1.0
Rubber tire on grass	0.4

It may be desirable to allow the wheel to slip to prevent hydraulic system overheating when excessive loads are imposed should the vehicle stall. In this case TS should be just slightly larger than T.

Step Nine – Motor Radial Load Carrying Capacity

When a motor is used to drive a vehicle with the wheel mounted directly on the motor shaft or rotating hub, the Total Radial Load (RL) acting on the motor shaft is the vector summation of two forces acting at right angles to each other.

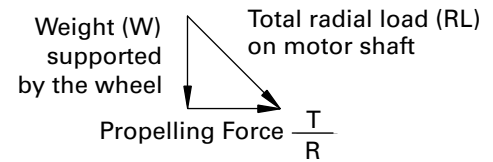

$$RL = \sqrt{W^2 + \left(\frac{T}{R}\right)^2}$$

Refer to radial load rating of each motor series.

Shaft Torque (T)

$$T = \frac{q \times DP}{2 \times p}$$

$$\frac{\text{bar} \times \text{cm}^3/\text{rev}}{62.8} = \text{Nm}$$

$$\frac{\text{PSI} \times \text{in}^3/\text{rev}}{6.28} = \text{lb - in}$$

Shaft Speed (N)

$$N = \frac{\text{Flow}}{\text{Displacement}}$$

$$\text{RPM} = \frac{1000 \times \text{l/min}}{\text{cm}^3/\text{rev}} \quad \text{RPM} = \frac{231 \times \text{GPM}}{\text{in}^3/\text{rev}}$$

Power (into motor)

$$Kw = \frac{\text{bar} \times \text{l/min}}{600} \quad \text{HP} = \frac{\text{PSI} \times \text{GPM}}{1714}$$

Power (out of motor)

$$Kw = \frac{\text{Nm} \times \text{RPM}}{9549} \quad \text{HP} = \frac{\text{lb-in} \times \text{RPM}}{63,025}$$

where: Kw = Kilowatt
HP = Horsepower
LPM = Liters per Minute
GPM = Gallons per Minute
Nm = Newton Meters
lb-in = Pound inch
Bar = 10 Newtons per Square Centimeter
PSI = Pounds per Square Inch
q = Displacement

Optional Features

OPTIONAL FEATURE	BENEFIT
2 Speed motors	Allows motor to have two displacements (higher speed has lower torque)
Seal Guard	Prevents physical damage to shaft seal from foreign debris
High pressure Shaft Seal	More robust shaft seal that can withstand high case pressure spikes
Environmental protection	Epoxy coating for demanding application in harsh environment
Nickel Plated Shaft Nickel Plated Body	For highly corrosive environment or food/sanitary applications
Integrated Parking Brake	Spring applied hydraulic release brake
Mechanical Disc Brake	Bolt on caliper brake for wheel motor applications
Free running option	Improved mechanical efficiency at high-speed/high-flow conditions
Speed sensors	To collect speed and/or direction information from a motor and provide electric signal
Shuttle valve	Redirect some low pressure oil for increased cooling in closed loop applications
Case port	To increase lubrication and flushing of the motor and reduce case pressure , extend seal life
Internal check valves	Relieves the case pressure to the low pressure port
Low speed valving	For better efficiency and smooth running at low speed conditions (<200 RPM)
Vented Two-Stage seal	Extends shaft seal life
Viton seals	For higher temperature or chemical resistance applications
Integral cross over valving	Cost effective design that limits the differential pressure across the motor
Metric Shafts, Ports, & Mounts	EU specific threads
Reverse Rotation	Allows clockwise shaft rotation with B port pressurized
ATEX	Certifies motor to be used in explosive environments

TYPICAL APPLICATIONS*

OPTIONAL FEATURES	WINCH	SWING DRIVES	SWEEPER BRUSH DRIVES	AUGER	INDUSTRIAL CONVEYOR	CAR WASH	TURF PROPEL	IRRIGATION REELS	MIXERS/GRINDERS	PLASTIC INJECTION MOLDING	TRACTION DRIVES	TRENCHER CHAIN DRIVES	SALT SAND SPREADER	MARINE WINCHES
2 Speed Motors	x			x				x			x			x
Seal Guard			x				x		x			x		
Viton Seals					x					x				
High Pressure Shaft Seal	x								x					
Environmental protection					x	x							x	x
Nickel Plated Shaft					x	x							x	x
Nickel Plated Body					x									
Integrated Parking Brake	x	x			x			x			x			x
Mechanical Disc Brake							x				x			
Free running option		x												
Speed sensors					x			x	x	x		x	x	
Shuttle valve							x		x		x	x		
Case port	x	x	x	x	x		x		x		x	x		
Internal check valves					x	x	x							
Low speed valving		x			x		x				x		x	
Vented Two-Stage seal					x	x	x				x			
Integral cross over valving	x	x		x										x
Metric Shafts, Ports, & Mounts	x	x	x	x	x	x	x	x	x	x	x	x	x	x
Reverse Rotation					x									

* These features are not limited to these applications. Final configuration depends on individual application needs.

Optional Features

FEATURE DESCRIPTION	CATALOG PAGE NUMBER	SPOOL VALVE MOTORS					DISC VALVE MOTORS					VIS MOTORS	
		J Series	H Series	S Series	T Series	W series	2000 Series	4000 Compact Series	4000 Series	6000 Series	10000 Series	VIS 40	VIS 45
2 Speed motors	A-11	—	—	—	—	—	0	—	—	—	0	0	0
Seal Guard	A-12	—	0	0	0	—	0	0	0	0	0	0	0
Viton seals	A-12	0	0	0	0	0	0	0	0	0	0	0	0
High pressure Shaft Seal	A-13	—	0	0	0	—	0	0	—	—	—	—	—
Environmental protection	A-13	0	0	0	0	0	0	0	0	0	0	0	0
Nickel Plating Options	A-20	0	0	0	0	0	0	0	0	0	0	—	—
Integrated Parking Brake	A-14	—	—	—	0	0	—	—	—	—	—	0	0
Mechanical Disc Brake	A-14	—	—	—	—	0	0	0	—	—	—	—	—
Free running option	A-15	0	0	0	0	0	0	0	0	0	0	0	0
Speed sensors	A-16	0	0	0	0		0	0	0	0	0	—	—
Shuttle valve	A-17					0	0	0	0	0	—	0	0
Case port	A-18	0	0	0	0	0	S	S	S	S	S	S	S
Internal check valves	A-18	S	0	S	0	0	—	—	—	—	—	—	—
Low speed valving	A-19	—	0	0	0	S	—	—	—	—	—	—	—
Vented Two-Stage seal	A-20	—	0	0	0		—	—	—	—	—	—	—
Integral cross over valving	A-21	—	—	—	—		0	0	—	—		—	—
Metric Shafts, Ports, & Mounts	—	0	0	0	0	0	0	0	0	0	0	0	0
Reverse Rotation	—	0	0	0	0	0	0	0	0	0	0	0	0
ATEX Certification			0	0	0		0	0	0	0	0	0	0

0 Optional
 S Standard
 — Not applicable

Two Speed Motors

This option is available on all 2000, 10,000, VIS 40 and VIS 45 motors.

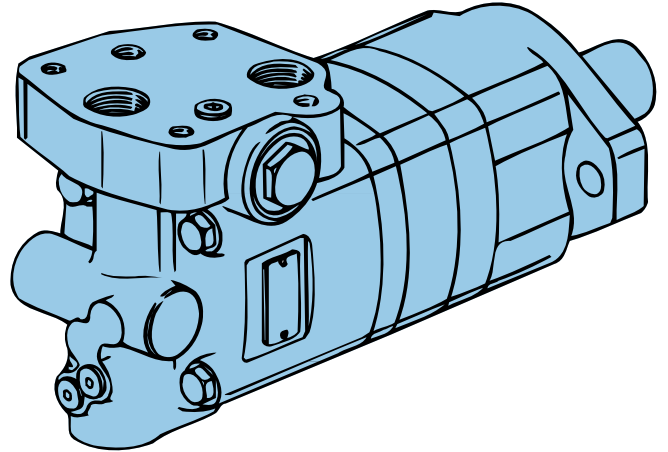

Features:

This option gives the user the ability to switch the displacement of the motor thus providing a different speed at a different torque without changing the input flow or pressure. An external three way valve is required for shifting the pilot pressure port between signal pressure (HSLT) and low pressure (LSHT).

Two speed motors are available with a return line closed center shuttle for closed circuit applications.

Benefits:

- Two operating speeds and torque levels with one motor
- Two selectable performance ranges in one motor package

Application:

- Conveyors
- Winches
- Traction drives
- Augers
- Irrigation/utility cable reels

Seal Guard

This option is available on H, S, T, 2000, 4000, 6000, 10,000, VIS 40 and VIS 45 series motors

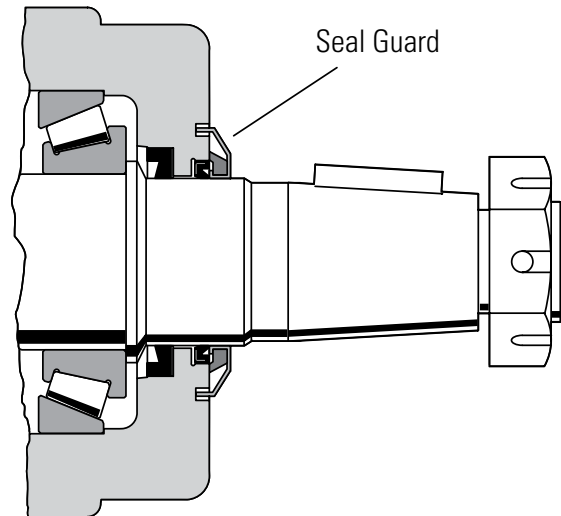

Features:

This option consists of a metal shield that protects an internal wiper seal. The shield is interference-fit on the output shaft and moves with the output shaft. For added protection, the shield is recessed into a groove in the bearing housing face.

Benefits:

Centrifugal force causes foreign debris to be forced away from the high pressure shaft and dust seal area. The seal does not seal hydraulic fluid, instead it protects the standard seals from damage caused by foreign debris.

Applications:

- Street sweepers
- Industrial sweepers
- Lawn and turf equipment (ZTR)
- Harvesting machinery
- Mining equipment

Viton Seals

This option is available on all Char-Lynn motors.

Features:

Higher chemical compatibility and temperature tolerance make Viton the material of choice for demanding application in extremely corrosive and harsh environments.

Benefits:

- Longer seal life in chemically aggressive environment
- Operating Temperature Range of -25°C to 200°C [-13°F to 392°F]

Applications:

- Industrial conveyors
- Plastic injection molding

Note: Minimum Viscosity Levels must still be maintained

High Pressure Seals

This option is available on H, S, T and 2000 series motors.

Features:

Eaton has introduced a high-pressure shaft seal option for its H, S, T and 2000 series motors. The seal geometry is optimized for applications that operate under extreme conditions. The seal geometry increases the clamping force of the sealing lip against the output shaft to prevent seal leakage at extreme pressure conditions. Case pressure forces the lip of the seal to clamp more tightly against the output shaft. The result is a seal that handles high pressure spike conditions without failure. The seal is designed to withstand case pressures up to 200 bar [2900 PSI] at 150 rpm.

For reference, the standard seal can withstand case pressure up to:

- 100 bars (1500 PSI) for H, S, T motors
- 140 bars (2000PSI) for 2000 Series
- 100 bars (1500 PSI) for 4000 Series
- 70 bars (1000 PSI) for 6000 Series
- 20 bars (300 PSI) for the 10,000 Series
- 20 bars (300 PSI) for VIS 40, 45

Benefits:

- Increases ability to handle high-pressure spike conditions.
- Eliminates the use of case port line in application with intermittent extreme operating conditions.
- Can be an effective alternative to additional case port plumbing.
- Operating Temperature -40°C to 150°C [-40°F to 300°F]

Special Notes:

1. Intermittent operation is defined as 10% of every minute.
2. The standard seal with case port option is preferred for maximum life – especially for continuous duty at high pressure conditions.
3. Seal kits are available to convert motors with the standard shaft seal to the high pressure shaft seal. (complete motor seal kits include high pressure shaft seal).
4. Minimum Viscosity Levels must be maintained.

Applications:

- Harvesters
- Sweepers
- Turf Equipment
- Wood Chippers
- Stump Grinders
- Skid Steer Loader Attachments (often loaders have no case line available)
- Any application with extreme intermittent operating conditions or where no case return line is available.

Part Numbers:

H Series – Kit No. 60572-000

S Series – Kit No. 60578-000

T Series – Kit No. 60579-000

Shaft Seal – Part No. 14778-001

2000 Series – Kit No. 61329-000.

Shaft Seal – No. 14857-001

Brake Solutions

Integrated brake options are available for all T, W, and VIS 40 series motors. Mechanical bolt-on packages are available for all W, 2000 and 4000 Compact series motors.

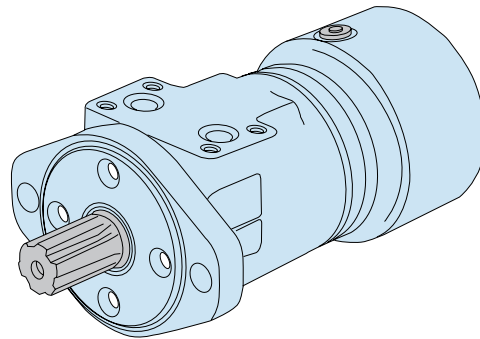
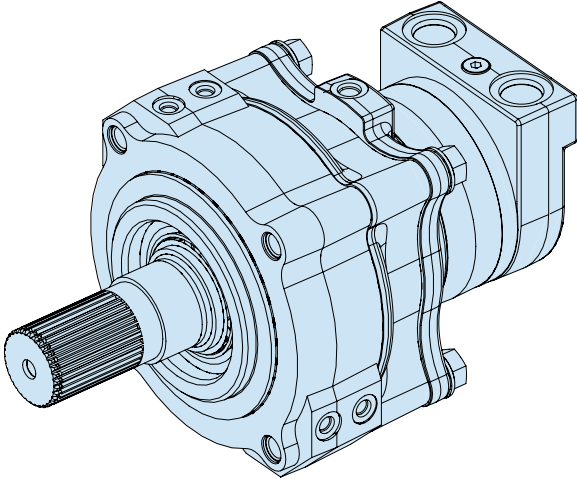

Features:

Eaton continues to develop and bring new brake solutions to market that are performance matched to each motor series. These include:

- T Series with Integrated Parking Brake
- W Series with Integrated Parking Brake
- VIS Series with Integrated Parking Brake

In addition, Eaton brake motors can be mated with bolt-on valve packages to provide dynamic braking hydraulically using state of the art counter-balance valve technology.

There are also a variety of bolt-on mechanical brake options including Hayes brake system. This compact brake package can be used on 2000 Series and W Series wheel motors.

Benefits:

- Complete compact system package
- Performance-matched brake / motor solution
- Increases design flexibility
- Reduces assembly costs and simplifies service requirements
- Streamlines inventory and order processing.
- Ability to direct port release pressure (eliminate brake release hose correction)

Applications:

- Aerial Work Platforms
- Boom Lifts
- Track Cranes
- Forestry Grapples
- Winches
- Traction Drives
- Anywhere load holding is a requirement in a LSHT motor application

Free Running Geroler Sets/Gerotor Sets

This feature is available in all Char-Lynn motors.

Features:

The free running option is accomplished using a specially precision-machined gerotor/geroler assembly. This feature increases the clearance between the star and mating ring, allowing the motor to turn more freely with less mechanical drag. The increased clearance also improves lubrication across the wear surfaces of the gerotor star and ring and provides a

greater pressure-relieving flow path reducing pressure spikes. Flow is by-passed internally across the star tips, reducing shock loads to the main drive components. This feature provides an effective method for reducing shock loads to the main drive components.

Benefits:

- Suited for applications with rapid stop/start or rapid reversals.

- Reduces starting pressure and increases starting torque efficiency.
- Reduces pressure spikes through the orbit gear set.

Applications:

- Harvesters
- Stump Grinders
- Skid Steer Loader Attachments
- Machine Tools
- Especially suited for continuous high speed/high flow applications.

- Also suited for applications with high-pressure spikes from rapid reversals.

Special Notes:

Volumetric Efficiency will be reduced with the free-running option.

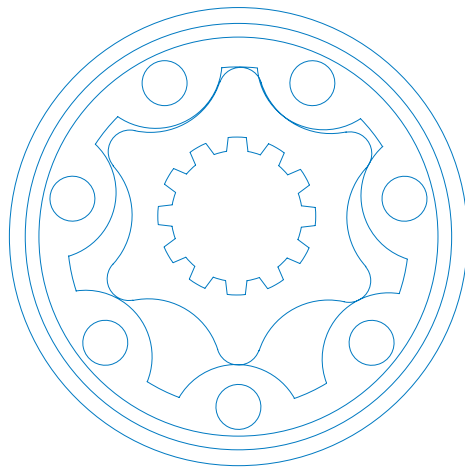

Gerotor

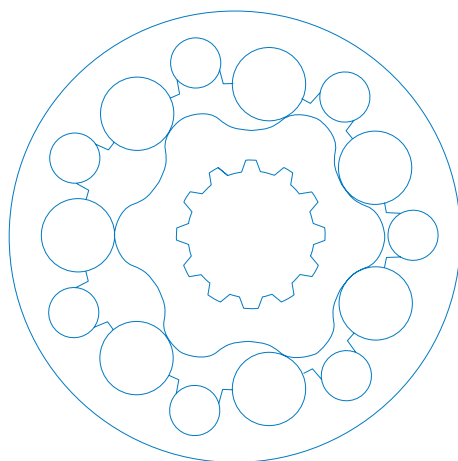

Geroler

Gerotor or Geroler?

The H series motor uses a Gerotor while the rest of the Char-Lynn motors use a Geroler. The difference is shown in the picture below:

Essentially a Geroler, has rolls added to the lobes of the outer ring of the Orbit gear set. These rolls act as a roller bearing and reduce friction, increase mechanical efficiency and reduce wear in systems with low fluid viscosity. In addition, the Geroler type typically provides smoother performance at low speed conditions. The basic formula and guideline to determine whether a gerotor or Geroler should be used is as follows:

20 x psi / RPM = SUS (use this formula to determine minimum fluid viscosity)

RPM = speed of output shaft in revolutions per minute

SUS = minimum viscosity measured in SUS.

The recommended viscosity limits are as follows:

- 1) A Gerotor Orbit gear set requires a minimum fluid viscosity of 100 SUS or the value calculated by the formula $20 \text{ psi/RPM} = \text{SUS}$.
- 2) A Geroler Orbit gear set requires a minimum fluid viscosity of 70 SUS.

In addition, applications running at less than 100 rpm should consider using a Geroler motor.

Speed Sensors

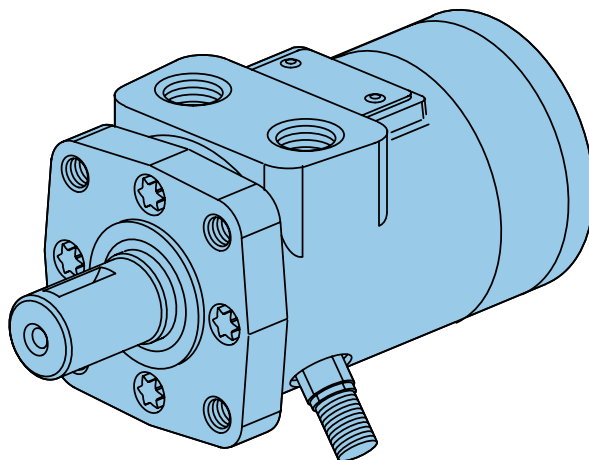

Note:

The speed sensor option does NOT include read-out display. Possible sources for read-out display include:

Eaton Corporation Durant Products 901 South 12 Street Watertown, WI 57094 — Phone 1-800-289-3866.

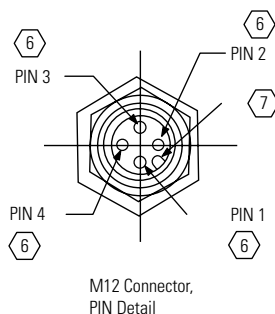

Features:

Eaton has developed speed sensors specifically designed for LSHT motors.

The single output speed sensor:

This design is rugged and fully protected against accidental reverse polarity or short circuit hook up. A built in pull up resistor simplifies installation with control systems. This sensor is fully compatible with the mobile vehicle electrical systems and gives a reliable digital on/off signal over a wide speed range and temperature range. The sensor is field-serviceable; no factory setting or shimming is required.

The dual output speed sensor:

This sensor provides both speed and direction information. Its design is based on the field proven technology of our standard sensor and is designed for off road environments. The new sensor is based on the principle of quadrature.

- The first version speed sensor has two output signals 90° out of phase. Each output provides one pulse per target.
- The second version has a speed signal that is twice the output pulses per revolution and it also has a direction signal. (Direction not available on spool motors)

Benefits:

These speed sensors provide vital information that can be collected and interpreted by a PLC or other device.

Applications:

- Salt/Sand Spreaders
- Irrigation Drives
- Machine Tools
- Mixers/Grinders
- Industrial Conveyors
- Food Processing Equipment
- Underground Boring Equipment

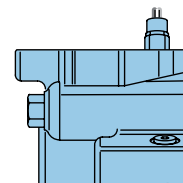
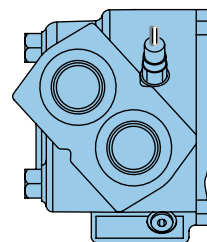
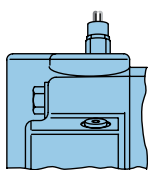
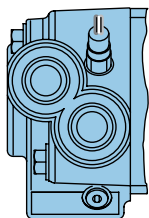
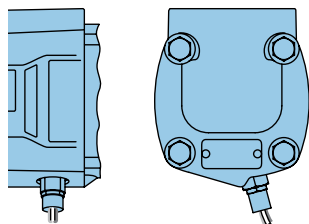

TECHNICAL INFORMATION

Motors	Speed Sensor Pulses Per Rev	Quadrature Pulses Per Rev
J,H,S,T,W	15	60
2000 series	30	60
4000 series	30	72
6000 series	30	80
10,000 series	30	60

Single and Two Outputs:

Supply Voltage: 8 to 24 Vdc (compatible with 12V vehicle systems)

Supply Current: 20 mA max. (Vs) (including internal pull-up resistor)

Output Voltage: Low < .5 Vdc @ 10 mA; output is open collector with 10kW pull-up resistor

M12 Connector (version 1)

- Pin 1 = Power supply
- Pin 2 = Output one
- Pin 3 = Common
- Pin 4 = Output two

M12 Connector (version 2)

- Pin 1 = Power Supply
- Pin 2 = Direction
- Pin 3 = Common
- Pin 4 = Speed signal

Shuttle Valve

Lubricating Shuttle

The shuttle valve option is available in W, 2000, 4000, 6000, and VIS series motors.

Features

Case Port allows for hydraulic oil to be flushed and cools the system. In applications where more system cooling and flushing is required.

Benefits

- Flushing
- Cooling
- Longer system life

Applications

- Turf Propel
- Mixers/Grinders
- Traction drives
- Trencher chain drives

Closed Loop Circuit

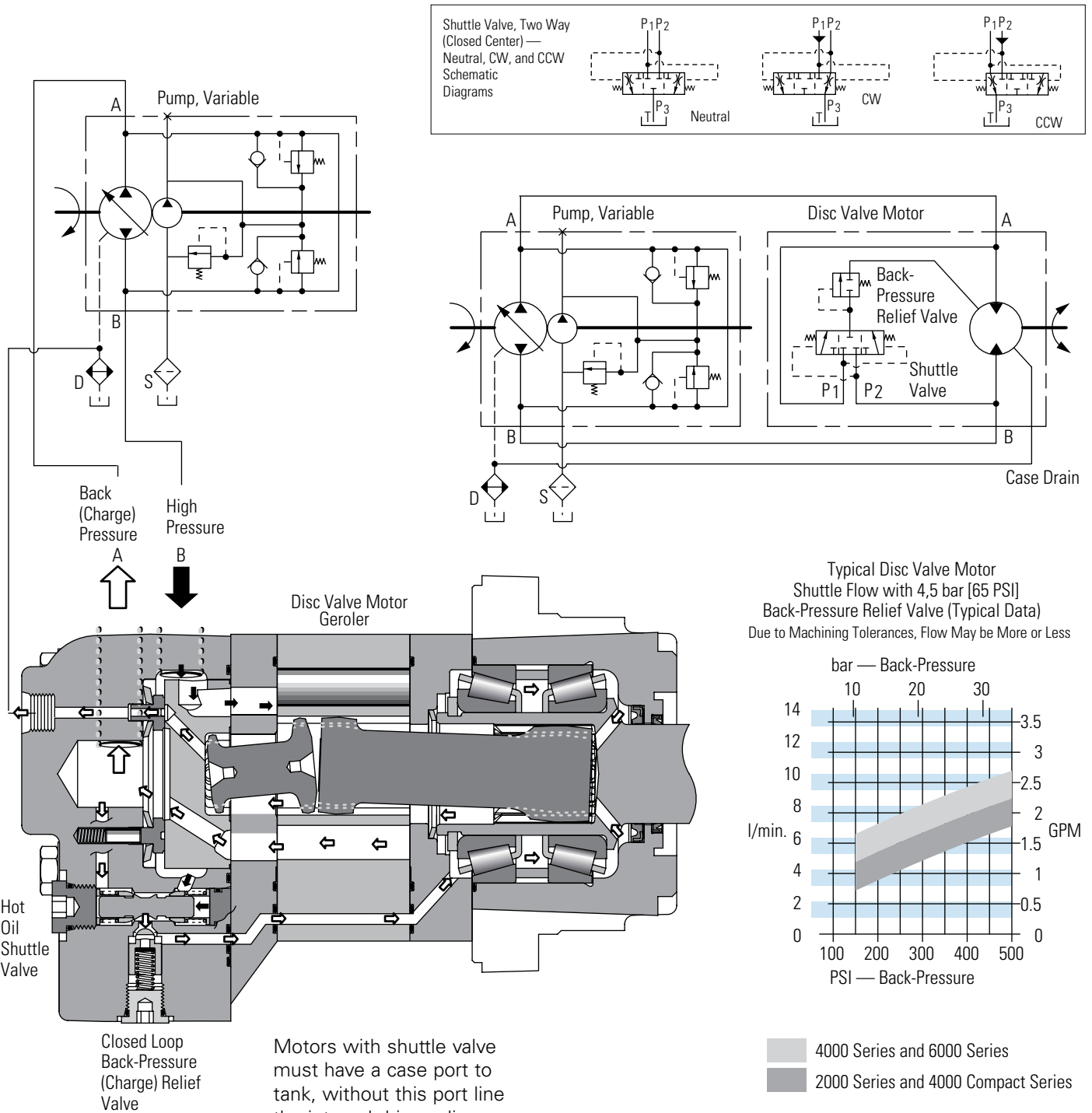

Motors with shuttle valve must have a case port to tank, without this port line the internal drive splines will not have adequate lubrication.

Case Porting

This option is available on all Char-Lynn Motors.

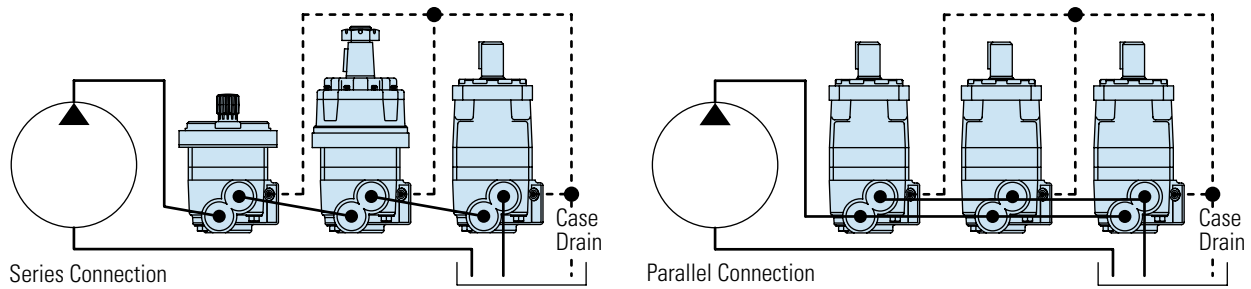

Features:

This feature provides for connection of a port line connected to the motor case.

A port is located in the motor direct to motor case pressure that allows the case pressure to be returned directly to tank. Internal leakage to the motor case cavity can be drained directly which reduces case pressure and provides flushing of the system circuit.

Benefits:

- Extends shaft seal life
- Extends thrust bearing life
- Reduces shaft seal leakage problems
- Improves flushing of the circuit to reduce system contaminates and cooling the system.

Applications:

- Especially suited for continuous running industrial applications and where motors are operating under high back pressure conditions (e.g. series circuit applications).
- Conveyers
- Car wash
- Harvesters
- Recommended for applications running with high case pressure conditions

Low Speed Valving

This option is available on H, S, T and W series motors.

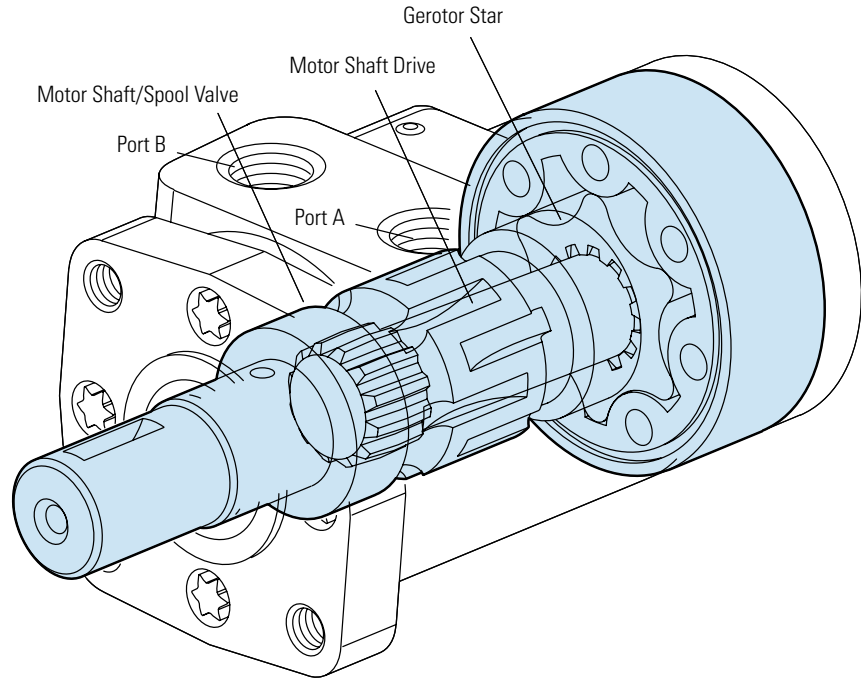

Features:

This feature optimizes the motor for low-speed performance. It greatly improves smooth operation at speeds below 200 rpm. The valving is optimized with increased sealing and tighter clearances. Motors with this feature are designed to run continuously up to 200 rpm at standard rated pressures.

Benefits:

- Improves smoothness at low speed conditions (less than 200 rpm)
- Improves volumetric efficiency

Applications:

- Salt-sand spreaders
- Machine tools
- Irrigation drives
- Consider for applications running at low speed conditions below 200 rpm.

Notes:

Motors with this valving are not intended for low pressure applications (A minimum of 300 psi delta must be maintained between A port pressure and case pressure)

Nickel Plating Options

Full Body Nickel Plating

This option is available on H, S, T, 2K, 4K, 6K motors.

Features:

Eaton is offering full body nickel plating for Char Lynn Motors for protection against wash down environments (Note: this does not offer protection against salt water environments and the recommended option for that is epoxy paint). In order to meet the different requirements, Eaton is now offering two different nickel plating options shown below:

Benefits:

- Protection in heavy and frequent washdown environments
- Single source plating at a competitive prices
- Warranty from Eaton on nickel plating

Applications:

- Food Processing: Industrial Conveyors

Choosing the options in the model code:

- H, S, T Motors - Choose Option Y in Paint / Packaging Options
- 2000, 4000, 6000 Series - Choose Option

OPTION	DESCRIPTION	APPLICATIONS
Electroless Nickel Plating (AMS 2404D specification)	Premium process offering extremely high quality corrosion resistance	Where water contact is extremely high ⁺
Electrolytic Nickel Plating (AMS-QQ-N-290 specification)	Good quality process offering standard corrosion resistance	Where water contact is minimal ⁺

+ Washdown applications only – does not include salt water applications

Nickel Plated Shafts

This option is available on H, S, T, motors.

Features:

Eaton is offering Electroless nickel plating on the shafts alone for corrosion protection primarily in wash down environments.

Benefits:

- Protection in heavy and frequent washdown environments
- Single source plating at a competitive prices
- Warranty from Eaton on nickel plating

Applications:

- Car Washes
- Fishing Winches / Marine applications

Environmental Protection

(epoxy paint)
(plated shafts)

This option is available on all Char-Lynn motors.

Features:

All motors are available with a corrosion resistant coating for use in hostile environments. The Char-Lynn line is also available with the output shaft plated, or with plated shaft and entire motor exterior coating.

Benefits:

This coating protects the motor from salt water and various chemicals. Motor output shaft plating helps eliminate seal damage caused by caustic or acidic materials.

Applications:

- Marine
- Food processing,
- Cleansing
- Fishing and agricultural applications

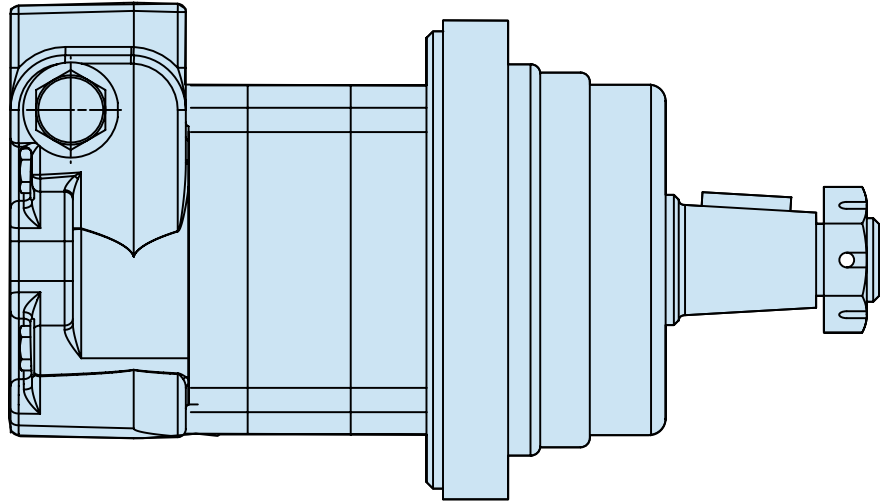

Features:

- Complete packaged system solution, single source for motors with relief valve capability
- Relief valves as close to Geroler as possible, providing added protection
- Eliminate leak points from in-line or bolt-on relief's
- Valves capable of full motor pressure
- Provides added flexibility to system design by allowing motors to have individual relief valve settings
- Simplifies assembly, purchasing and system design requirements

Benefits:

- This compact and efficient package offers increased value and cost effectiveness to designing Eaton into your applications.
- Minimizing the use of hoses, tubing and fittings will reduce production and assembly time significantly.

Applications:

- Skid-steer attachments
- Swing motors
- Brush cutters & Mowers
- Harvesting equipment
- Directional boring
- Winch
- Auger

Any place where pressure relief is optimal for system or motor performance and life

Replacement cartridges can be obtained by ordering the Item part number as listed below.

REPLACEMENT CARTRIDGES

Item part #	Item desc.	Relief valve setting
02-199291	RV5A-10-F-0-35/15	1500 PSI
02-199292	RV5A-10-F-0-35/17.5	1750 PSI
02-199293	RV5A-10-F-0-35/20	2000 PSI
02-199295	RV5A-10-F-0-35/22.5	2250 PSI
02-198563	RV5A-10-F-0-35/25	2500 PSI
02-199294	RV5A-10-F-0-35/27.5	2750 PSI
02-199296	RV5A-10-F-0-35/30	3000 PSI

Special Housings Bolt on Solutions

Cartridge Valves & Manifolds for Spool & Disk Valve Motors

We Manufacture Solutions

Designing hydraulic systems with Eaton-Vickers Cartridge Valves & Manifolds is a cost effective way of bringing your design into production well within the most demanding of production schedules. Minimizing the use of hoses, tubing and fittings will reduce production and assembly time significantly.

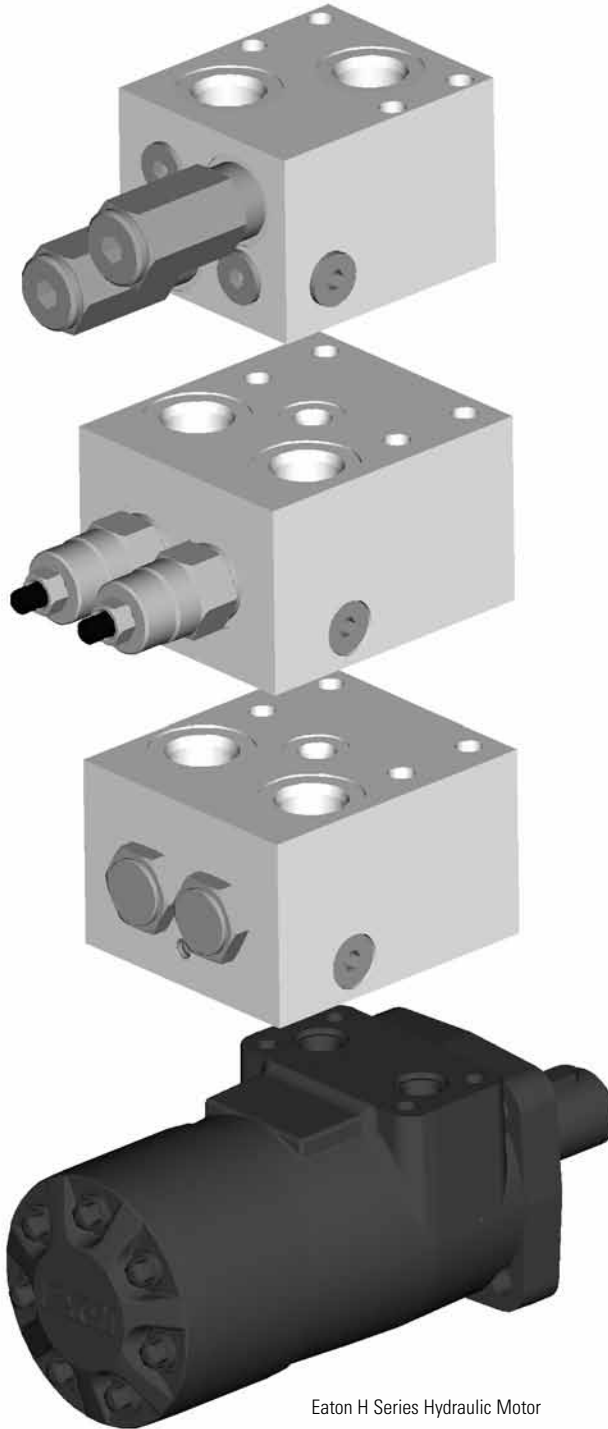

Features

- Compatible with Eaton H & T series spool valve motors, and most 2000 series disk valve motors
- Aluminum Manifolds Anodized Black
- Pre-set cartridges to your specifications
- 100% production tested assembly
- Wide range of settings available
- Intelligent model code
- Manifolds are available with out cartridge valves, or pre-assembled and tested to your specifications
- Manifolds and motors can be supplied as a pre-assembled package
- Dual counterbalance valve (with integral shuttle valve), dual pilot operated check valve and dual cross port relief valve packages are available

Eaton H Series Hydraulic Motor

ICEHT35/ICEEHT35 - Motor Mounted Valves

H & T Mounting Pattern Single and Dual Overcenter Valves

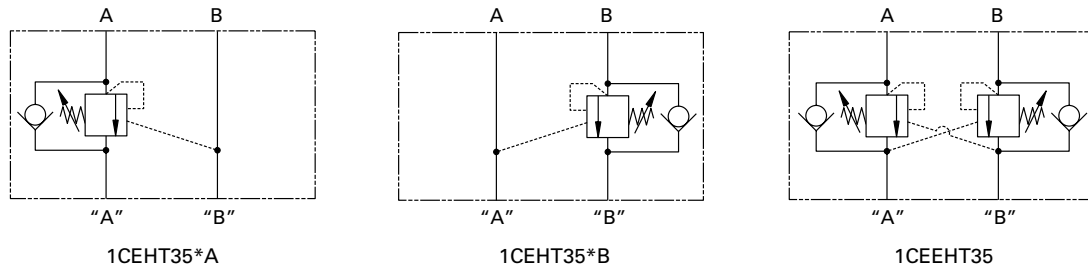

Description

Overcenter valves give static and dynamic control of loads by regulating the flow into and out of hydraulic actuators. When installed close to or within an actuator, the overcenter valve will stop runaway in the event of hose burst and if open center directional control valves are used, will allow thermal expansion relief of the hydraulic fluid. The overcenter cartridge is ideal for mounting directly into a cavity machined in the body of the cylinder, motor or rotary actuator.

The cartridge can also be mounted directly to the ports via a specifically machined body as part of a Hydraulic Integrated Circuit or single unit, or contained within one of our standard line bodies.

Single overcenter valves are normally used when the load is unidirectional, for example an aerial platform or crane and dual overcenter valves are used for controlling loads in both directional for motor applications or for cylinders going over center.

Operation

The check section allows free flow into the actuator then holds and locks the load against movement. The pilot assisted relief valve section will give controlled movement when pilot pressure is applied. The relief section is normally set to open at a pressure at least 1.3 times the maximum load induced pressure but the pressure required to open the valve and allow movement depends on the pilot ratio of the valve. For optimization of load control and energy usage, a choice of pilot ratios is available.

The pressure required to open the valve and start actuator movement can be calculated as follows:

$$\text{Pilot Pressure} = \frac{(\text{Relief Setting}) - (\text{Load Pressure})}{\text{Pilot Ratio}}$$

Pilot Ratios

- 2.5:1 Best suited for extremely unstable applications such as long booms or flexible frameworks.
- 5:1 Best suited for applications where load varies (Standard) and machine structure can induce instability
- 10:1 Best suited for applications where the load remains relatively constant.

Performance Data

Ratings and Specifications

Figures based on: Oil Temp = 40°C Viscosity = 32 cSt (150 SUS)

Rated flow	30 L/min (8 USgpm)		
Max setting	Max load induced		
	Pressure:	270 bar (4000 psi)	
	Relief setting:	350 bar (5000 psi)	
Cartridge material	Working parts hardened & ground steel External surface zinc plated		
Body material	Standard aluminium (up to 210 bar*) Steel (up to 350 bar)		
Mounting position	Unrestricted		
Cavity Number	A6610 (See section M)		
Torque cartridge into cavity	45 Nm (33 lbs ft)		
Weight	1CEOMP35	1.6 kg	(3.52 lbs)
(inc cartridges)	1CEEOMP35	1.66 kg	(3.65 lbs)
Seal kit number	1CEHT35	9900834-000 (Buna-N)	9900835-000 (Viton)
	1CEEHT35	9900836-000 (Buna-N)	9900837-000 (Viton)
Recommended filtration level	BS5540/4 Class 18/13 (25 micron nominal)		
Operating Temp	-30°C to +90°C (-22° to 194°F)		
Leakage	0.3 milliL/min nominal (5 dpm)		
Nominal viscosity range	5 to 500 cSt		
Installation Kit (includes cap screws, washers, and o-rings)	9900828-000 (Buna-N) 9900829-000 (Viton)		

ICEHT35/ICEHT35 - Motor Mounted Valves

H & T Mounting Pattern Single and Dual Overcenter Valves

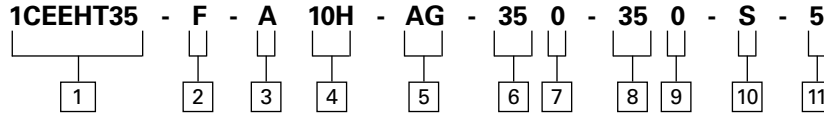
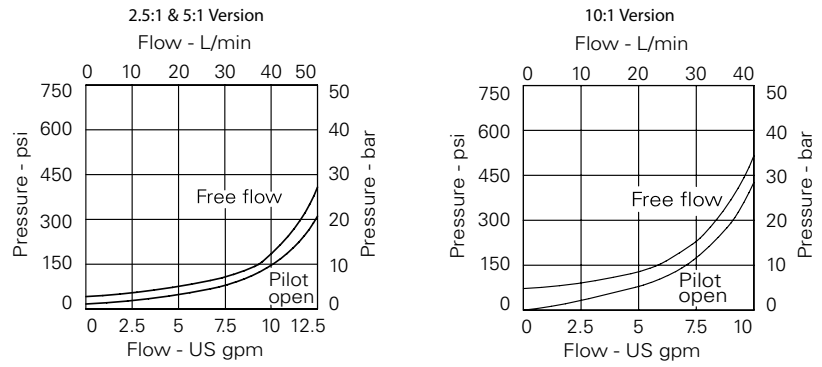

1 Basic Code

1CEEHT35 - Double Cartridge and Body
 1CEEHT35*A - Single overcenter in line A-"A"
 1CEEHT35*B - Single overcenter in line B-"B"

2 Adjustment Means

F - Screw Adjustment

3 Housing Material

A - Aluminum
 S - Steel

4

Code	Port Size "A" & "B"	Dual Housing Number	
		Aluminum	Steel
4W	1/2" BSP	6024221-001	6024221-003
10H	SAE 10	6024221-002	
10T	SAE 10		6024221-04

5 Port Acted Upon

A - A Port
 B - B Port
 AB - A & B Ports (dual)

6 Pressure Range (Cart A)

Note: Code Based on pressure in bar.

20 - (2.5:1 and 5:1): 70-210 bar. Std setting 100 bar.
 (10:1): 100-210 bar. Std setting 100 bar.

35 - (2.5:1 and 5:1): 100-350 bar. Std setting 210 bar.
 (10:1): 120-350 bar. Std setting 210 bar.

7 Pressure Setting (Cart A)

0 - Std factory setting
 1500 - 1500 psi

8 Pressure Range (Cart B)

Note: Code Based on pressure in bar.

20 - (2.5:1 and 5:1): 70-210 bar. Std setting 100 bar.
 (10:1): 100-210 bar. Std setting 100 bar.

35 - (2.5:1 and 5:1): 100-350 bar. Std setting 210 bar.
 (10:1): 120-350 bar. Std setting 210 bar.

9 Pressure Setting (Cart B)

0 - Std factory setting
 1500 - 1500 psi

10 Seals

S - Buna-N
 SV - Viton

11 Pilot Ratio

2 - 2.5:1
 5 - 5:1
 10 - 10:1

Cavity plug part number

Nitrile - AXP13032-01-N
 Viton - AXP13032-01-V

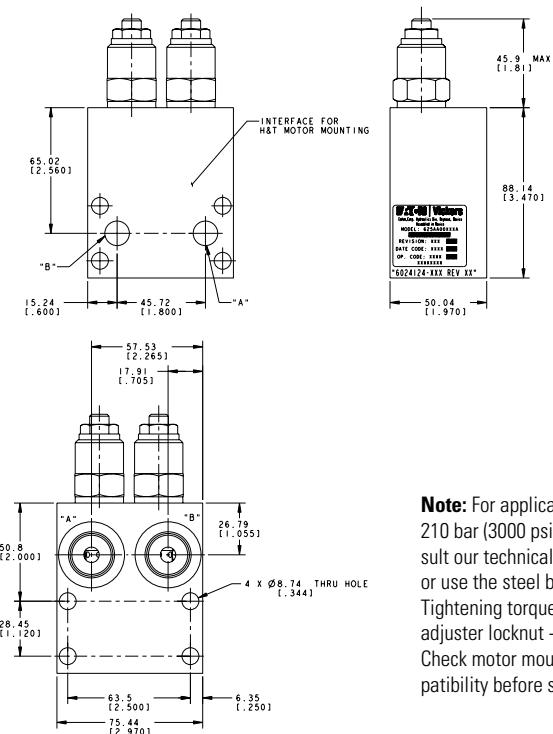

Note: For applications over 210 bar (3000 psi), please consult our technical department or use the steel body option. Tightening torque of "F" adjuster locknut - 20 to 25 Nm. Check motor mounting compatibility before specifying.

ICESHHT35/ICEESHHT35 - Motor Mounted Valves

H & T Mounting Pattern Single and Dual Overcenter Valve with Brake Release Shuttle

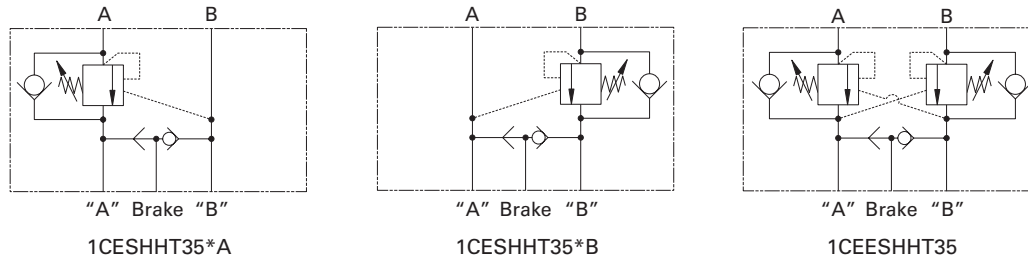

Description

Overcenter Valves give static and dynamic control of loads by regulating the flow into and out of hydraulic actuators. When installed close to or within an actuator, the overcenter valve will stop runaway in the event of hose burst and if open center directional control valves are used, will allow thermal expansion relief of the hydraulic fluid.

These dual overcenter valves also contain a brake release shuttle valve which ensures that pressure is applied to a brake release circuit regardless of whether pressure is applied to ports "A" or "B". These multifunction valves are normally used for the static and dynamic control of systems using motors or semi-rotary-actuators.

Operation

The check section allows free flow into the actuator then holds and locks the load against movement. The pilot assisted relief valve section will give controlled movement when pilot pressure is applied. The relief section is normally set to open at a pressure at least 1.3 times the maximum load induced pressure but the pressure required to open the valve and allow movement depends on the pilot ratio of the valve. For optimization of load control and energy usage, a choice of pilot ratios is available.

The pressure required to open the valve and start actuator movement can be calculated as follows:

$$\text{Pilot Pressure} = \frac{(\text{Relief Setting}) - (\text{Load Pressure})}{\text{Pilot Ratio}}$$

Pilot Ratios

- 2.5:1 Best suited for extremely unstable applications such as long booms or flexible frameworks.
- 5:1 Best suited for applications where load varies (Standard) and machine structure can induce instability
- 10:1 Best suited for applications where the load remains relatively constant.

Performance Data

Ratings and Specifications

Figures based on: Oil Temp = 40°C Viscosity = 32 cSt (150 SUS)

Rated flow	30 L/min (8 USgpm)		
Max setting	Max load induced		
	Pressure:	270 bar (4000 psi)	
	Relief setting:	350 bar (5000 psi)	
Cartridge material	Working parts hardened & ground steel External surface zinc plated		
Body material	Standard aluminium (up to 210 bar*) Steel (up to 350 bar)		
Mounting position	Unrestricted		
Cavity Number	A6610 (See section M)		
Torque cartridge into cavity	45 Nm (33 lbs ft)		
Weight	1CESHHT35	2.29 kg	(5.04 lbs)
(inc cartridges)	1CEESHHT35	2.34 kg	(5.15 lbs)
Seal kit number	1CESHHT35	9900834-000 (Buna-N)	9900835-000 (Viton)
	1CEESHHT35	9900836-000 (Buna-N)	9900837-000 (Viton)
Recommended filtration level	BS5540/4 Class 18/13 (25 micron nominal)		
Operating Temp	-30°C to +90°C (-22° to 194°F)		
Leakage	0.3 milliL/min nominal (5 dpm)		
Nominal viscosity range	5 to 500 cSt		
Installation Kit (includes cap screws, washers, and o-rings)	9900828-000 (Buna-N) 9900829-000 (Viton)		

ICESHHT35/ICEESHHT35 - Motor Mounted Valves

H & T Mounting Pattern Single and Dual Overcenter Valve with Brake Release Shuttle

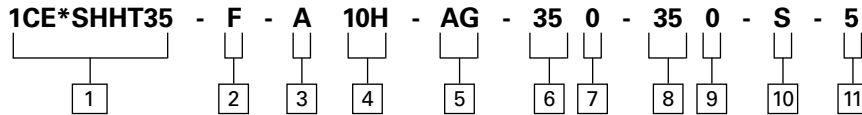
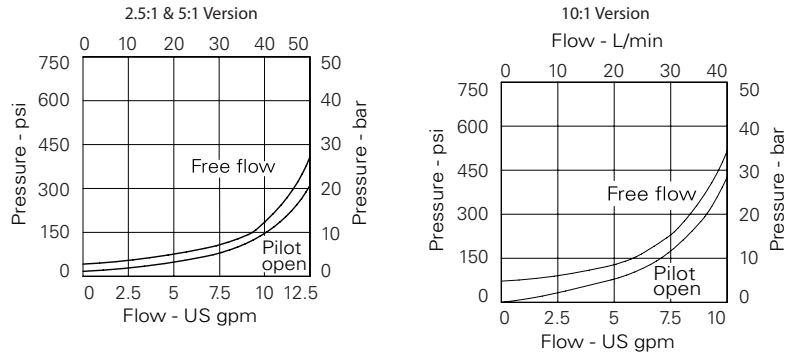

1 Basic Code

1CEESHHT35 – Double Cartridge and Body
 1CESHHT35*A – Single overcenter in line A-“A”
 1CESHHT35*B – Single overcenter in line B-“B”

2 Adjustment Means

F – Screw Adjustment

3 Housing Material

A – Aluminum
 S – Steel

4

Code	Port Size		Dual Housing Number	
	“A” & “B”	Brake	Aluminum	Steel
4W	1/2” BSP	1/4” BSP	6025216-001	6025216-003
10H	SAE 10	SAE 4	6025216-002	
10T	SAE 10	SAE 4		6025216-004

5 Port Acted Upon

A – A Port
 B – B Port
 AB – A & B Ports (dual)

6 Pressure Range (Cart A)

Note: Code Based on pressure in bar.

20 – (2.5:1 and 5:1): 70-210 bar. Std setting 100 bar.
 (10:1): 100-210 bar. Std setting 100 bar.

35 – (2.5:1 and 5:1): 100-350 bar. Std setting 210 bar.
 (10:1): 120-350 bar. Std setting 210 bar.

7 Pressure Setting (Cart A)

0 – Std factory setting
 1500 – 1500 psi

8 Pressure Range (Cart B)

Note: Code Based on pressure in bar.

20 – (2.5:1 and 5:1): 70-210 bar. Std setting 100 bar.
 (10:1): 100-210 bar. Std setting 100 bar.

35 – (2.5:1 and 5:1): 100-350 bar. Std setting 210 bar.
 (10:1): 120-350 bar. Std setting 210 bar.

9 Pressure Setting (Cart B)

0 – Std factory setting
 1500 – 1500 psi

10 Seals

S – Buna-N
 SV – Viton

11 Pilot Ratio

2 – 2.5:1
 5 – 5:1
 10 – 10:1

Cavity plug part number

Nitrile - AXP13032-01-N
 Viton - AXP13032-01-V

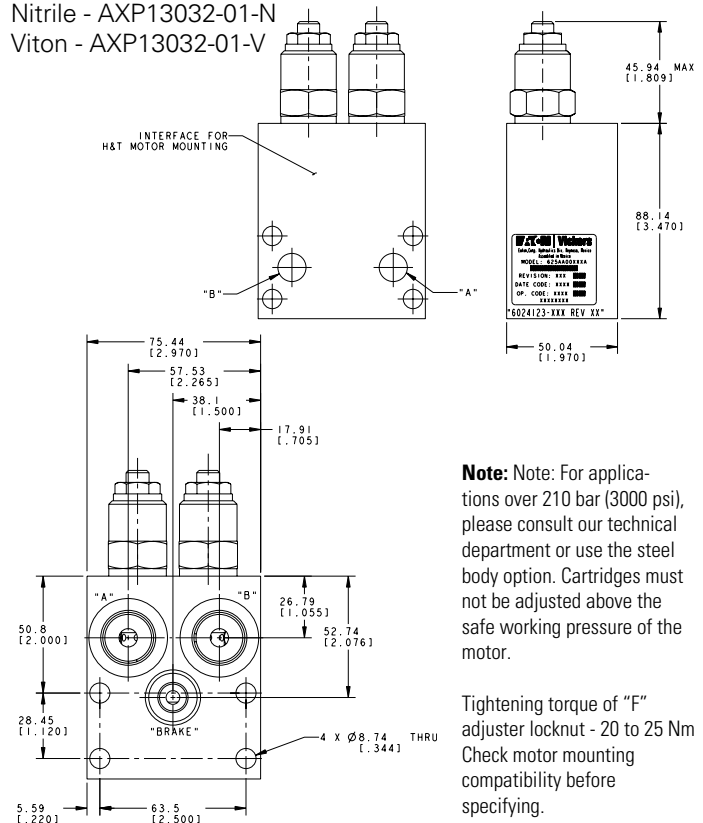

Note: Note: For applications over 210 bar (3000 psi), please consult our technical department or use the steel body option. Cartridges should not be adjusted above the safe working pressure of the motor.

Tightening torque of “F” adjuster locknut - 20 to 25 Nm
 Check motor mounting compatibility before specifying.

Dual Cross-over Relief Package for H&T Series Motors

Cartridge valves & manifolds for spool valve motors

Dual Crossover Relief Valve Assembly

This valve assembly provides motor over-pressure protection in both directions of rotation, while supplying the return or lower pressure side of the motor with makeup oil. If closed center valving is used, an additional function is controlled braking.

Typical applications are vehicle propulsion and motor work circuits in which pressure limiting is required.

How to Order

Complete pre-assembled packages are specified using the RV3A-10 model code. Option "A" must be selected for the cage seals,

position 6 of the model code is "H". To order the manifold separately, without the two RV3A cartridges, order the part number 4997062-001.

RATINGS AND SPECIFICATIONS

Rated flow	76 L/min(20USgpm)
Rated pressure	210 bar (3000psi)
Internal leakage (maximum)	less than 5 drops/min @ 85% of nominal setting
Manifold sub-assembly only	4997062-001
Installation kit (includes cap screws, washers and o-rings)	4997242-001

For detailed specifications refer to the RV3A-10 data sheet

Dimensions

mm (inch)

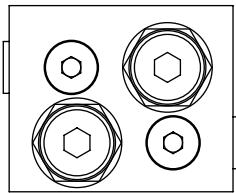

Port Sizes

"A", "B" – SAE10

"Brake" – SAE4

Functional Symbol

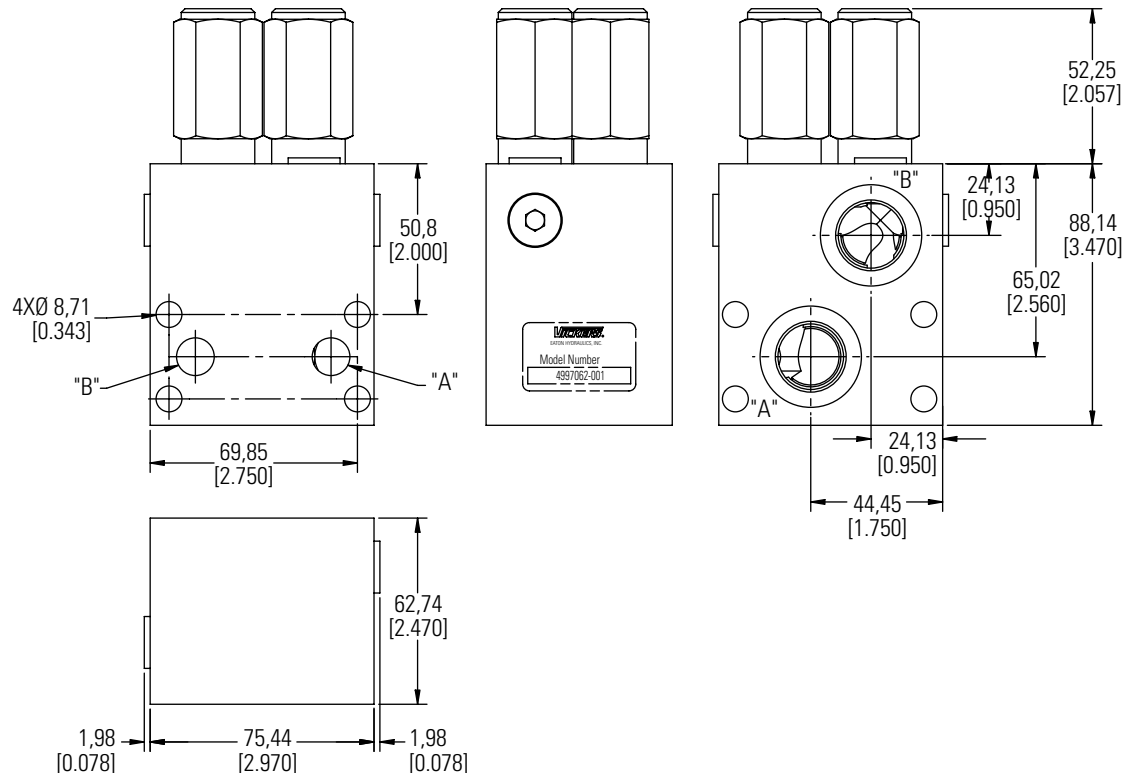
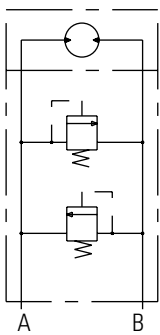

ICE2K95/1CEE2K95 - Motor Mounted Valves

2K Mounting Pattern Single and Dual Overcenter Valves

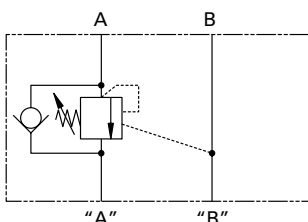

1CE2K95*A

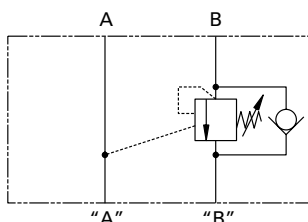

1CE2K95*B

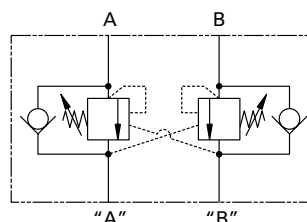

1CEE2K95

Description

Overcenter valves give static and dynamic control of loads by regulating the flow into and out of hydraulic actuators. When installed close to or within an actuator, the overcenter valve will stop runaway in the event of hose burst and if open center directional control valves are used, will allow thermal expansion relief of the hydraulic fluid.

The overcenter cartridge is ideal for mounting directly into a cavity machined in the body of the cylinder, motor or rotary actuator. The cartridge can also be mounted directly to the ports via a specifically machined body as part of a Hydraulic Integrated Circuit or single unit, or contained within one of our standard line bodies.

Single overcenter valves are normally used when the load is unidirectional, for example an aerial platform or crane and dual overcenter valves are used for controlling loads in both directions for motor applications or for cylinders going over center.

Operation

The check section allows free flow into the actuator then holds and locks the load against movement. The pilot assisted relief valve section will give controlled movement when pilot pressure is applied. The relief section is normally set to open at a pressure at least 1.3 times the maximum load induced pressure but the pressure required to open the valve and allow movement depends on the pilot ratio of the valve. For optimization of load control and energy usage, a choice of pilot ratios is available.

Performance Data

Ratings and Specifications

Figures based on: Oil Temp = 40°C Viscosity = 32 cSt (150 SUS)

Rated flow	90 L/min (23 USgpm)		
Max setting	Max load induced		
	Pressure:	270 bar (4000 psi)	
	Relief setting:	350 bar (5000 psi)	
Cartridge material	Working parts hardened & ground steel External surface zinc plated		
Body material	Standard aluminium (up to 210 bar*) Steel (up to 350 bar)		
Mounting position	Unrestricted		
Cavity Number	A12336 (See section M)		
Torque cartridge into cavity	60 Nm (44 lbs ft)		
Weight	1CE2K95	2.16 kg	(4.75 lbs)
(inc cartridges)	1CEE2K95	2.26 kg	(4.97 lbs)
Seal kit number	1CE2K95	9900830-000 (Buna-N)	9900831-000 (Viton)
	1CEE2K95	9900832-000 (Buna-N)	9900833-000 (Viton)
Recommended filtration level	BS5540/4 Class 18/13 (25 micron nominal)		
Operating Temp	-30°C to +90°C (-22° to 194°F)		
Leakage	0.3 milliL/min nominal (5 dpm)		
Nominal viscosity range	5 to 500 cSt		
Installation Kit (includes cap screws, washers, and o-rings)	9900826-000 (Buna-N) 9900827-000 (Viton)		

The pressure required to open the valve and start actuator movement can be calculated as follows:

$$\text{Pilot Pressure} = \frac{(\text{Relief Setting}) - (\text{Load Pressure})}{\text{Pilot Ratio}}$$

Pilot Ratios

- 4:1 Best suited for applications where load varies and machine structure can induce instability
- 8:1 Best suited for applications where the load remains relatively constant.

Other ratios available upon request

1CE2K95/1CEE2K95 Motor Mounted Valves

2K Mounting Pattern Single and Dual Overcenter Valves

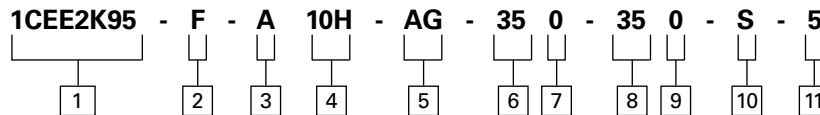
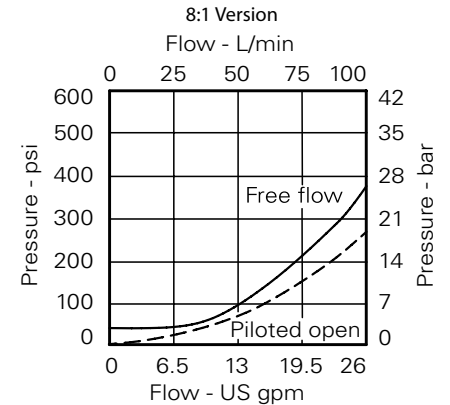
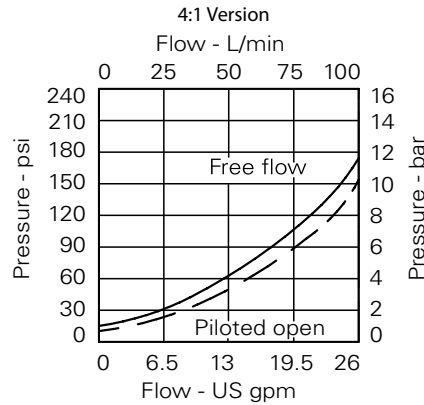

1 Basic Code

1CEE2K95 Double Cartridge and Body
 1CE2K95*A Single overcenter in line A-"A"
 1CE2K95*B Single overcenter in line B-"B"

2 Adjustment Means

F - Screw Adjustment

3 Housing Material

A - Aluminum
 S - Steel

4

Code	Port Size "A" & "B"	Dual Housing Number	
		Aluminum	Steel
4W	1/2" BSP	6025185-001	6025185-003
10H	SAE 10	6025185-002	
10T	SAE 10		6025185-004

5 Port Acted Upon

A - A Port
 B - B Port
 AB - A & B Ports (dual)

6 Pressure Range (Cart A)

Note: Code Based on pressure in bar.

20 - 70-225 bar. Std setting 100 bar.
 35 - 200-350 bar. Std setting 210 bar.

7 Pressure Setting (Cart A)

0 - Std factory setting
 1500 - 1500 psi

8 Pressure Range (Cart B)

Note: Code Based on pressure in bar.

20 - 70-225 bar. Std setting 100 bar.
 35 - 200-350 bar. Std setting 210 bar.

9 Pressure Setting (Cart B)

0 - Std factory setting
 1500 - 1500 psi

10 Seals

S - Buna-N
 SV - Viton

11 Pilot Ratio

4 - 4:1
 8 - 8:1

Cavity plug part number

Nitrile - AXP14434-02-N
 Viton - AXP14434-02-V

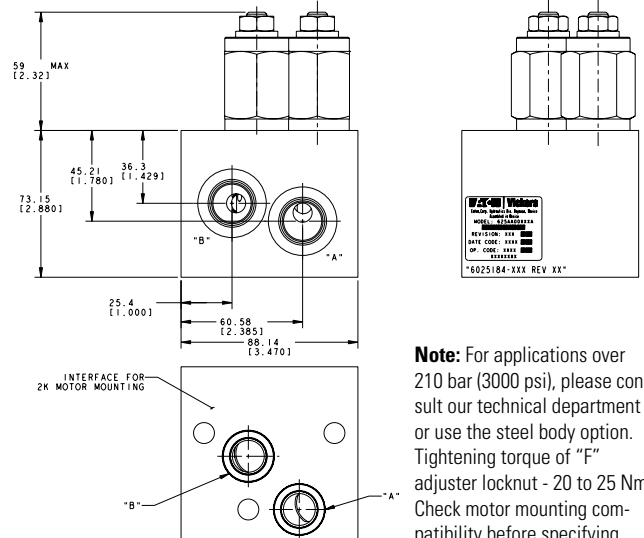
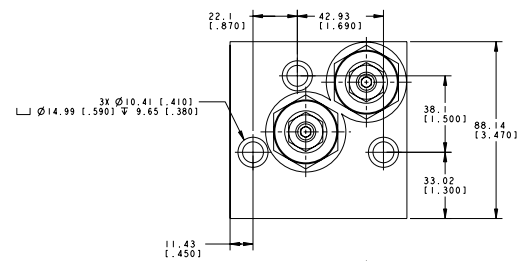

Note: For applications over 210 bar (3000 psi), please consult our technical department or use the steel body option. Tightening torque of "F" adjuster locknut - 20 to 25 Nm. Check motor mounting compatibility before specifying.

ICESH2K95/ICEESH2K95 - Motor Mounted Valves

2K Mounting Pattern Single and Dual Overcenter Valves with Brake Release Shuttle

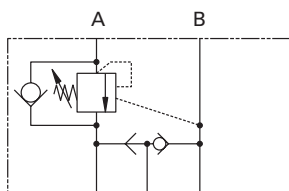

"A" Brake "B"
1CESH2K95*A

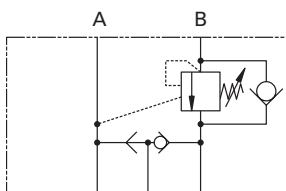

"A" Brake "B"
1CESH2K95*B

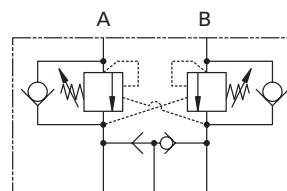

"A" Brake "B"
1CEESH2K95

Description

Overcenter Valves give static and dynamic control of loads by regulating the flow into and out of hydraulic actuators. When installed close to or within an actuator, the overcenter valve will stop runaway in the event of hose burst and if open center directional control valves are used, will allow thermal expansion relief of the hydraulic fluid.

These dual overcenter valves also contain a brake release shuttle valve which ensures that pressure is applied to a brake release circuit regardless of whether pressure is applied to ports "A" or "B". These multifunction valves are normally used for the static and dynamic control of systems using motors or semi-rotary actuators.

Operation

The check section allows free flow into the actuator then holds and locks the load against movement. The pilot assisted relief valve section will give controlled movement when pilot pressure is applied. The relief section is normally set to open at a pressure at least 1.3 times the maximum load induced pressure but the pressure required to open the valve and allow movement depends on the pilot ratio of the valve. For optimization of load control and energy usage, a choice of pilot ratios is available.

Performance Data

Ratings and Specifications

Figures based on: Oil Temp = 40°C Viscosity = 32 cSt (150 SUS)

Rated flow	90 L/min (23 USgpm)	
Max setting	Max load induced	
	Pressure:	270 bar (4000 psi)
	Relief setting:	350 bar (5000 psi)
Cartridge material	Working parts hardened & ground steel External surface zinc plated	
Body material	Standard aluminium (up to 210 bar*) Steel (up to 350 bar)	
Mounting position	Unrestricted	
Cavity Number	A12336 (See section M)	
Torque cartridge into cavity	60 Nm (44 lbs ft)	
Weight	1CESH2K95	2.32 kg (5.10 lbs)
(inc cartridges)	1CEESH2K95	2.42 kg (5.32 lbs)
Seal kit number	1CESH2K95 9900834-000 (Buna-N)	9900835-000 (Viton)
	1CEESH2K95 9900836-000 (Buna-N)	9900837-000 (Viton)
Recommended filtration level	BS5540/4 Class 18/13 (25 micron nominal)	
Operating Temp	-30°C to +90°C (-22° to 194°F)	
Leakage	0.3 milliL/min nominal (5 dpm)	
Nominal viscosity range	5 to 500 cSt	
Installation Kit (includes cap screws, washers, and o-rings)	9900828-000 (Buna-N) 9900829-000 (Viton)	

The pressure required to open the valve and start actuator movement can be calculated as follows:

$$\text{Pilot Pressure} = \frac{(\text{Relief Setting}) - (\text{Load Pressure})}{\text{Pilot Ratio}}$$

Pilot Ratios

- 4:1 Best suited for applications where load varies and machine structure can induce instability
- 8:1 Best suited for applications where the load remains relatively constant.

Other ratios available upon request

ICESH2K95/ICEESH2K95 - Motor Mounted Valves

2K Mounting Pattern Single and Dual Overcenter Valves with Brake Release Shuttle

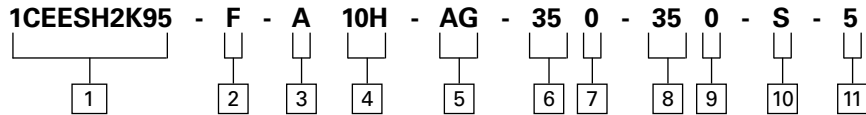
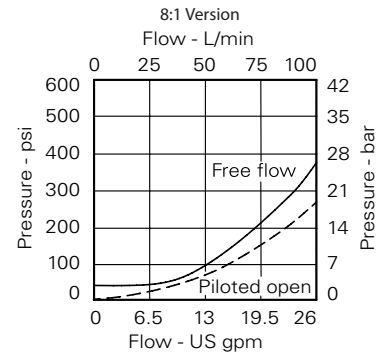
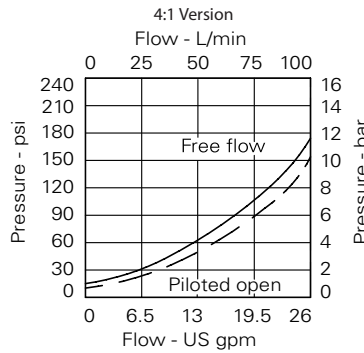

1 Basic Code

1CEESH2K95 - Double Cartridge and Body
 1CESH2K95*A - Single overcenter in line A-"A"
 1CESH2K95*B - Single overcenter in line B-"B"

2 Adjustment Means

F - Screw Adjustment

3 Housing Material

A - Aluminum
 S - Steel

4

Code	Port Size "A" & "B"		Dual Housing Number	
	"A"	"B"	Aluminum	Steel
4W	1/2" BSP	1/4" BSP	6025134-001	6025134-003
10H	SAE 10	SAE 4	6025134-003	
10T	SAE 10	SAE 4		6025134-004

5 Port Acted Upon

A - A Port
 B - B Port
 AB - A & B Ports (dual)

6 Pressure Range (Cart A)

Note: Code Based on pressure in bar.

20 - 70-225 bar. Std setting 100 bar.
 35 - 200-350 bar. Std setting 210 bar.

7 Pressure Setting (Cart A)

0 - Std factory setting
 1500 - 1500 psi

8 Pressure Range (Cart B)

Note: Code Based on pressure in bar.

20 - 70-225 bar. Std setting 100 bar.
 35 - 200-350 bar. Std setting 210 bar.

9 Pressure Setting (Cart B)

0 - Std factory setting
 1500 - 1500 psi

10 Seals

S - Buna-N
 SV - VitoN

11 Pilot Ratio

4 - 4:1
 8 - 8:1

Cavity plug part number

Nitrile - AXP13032-01-N
 Viton - AXP13032-01-V

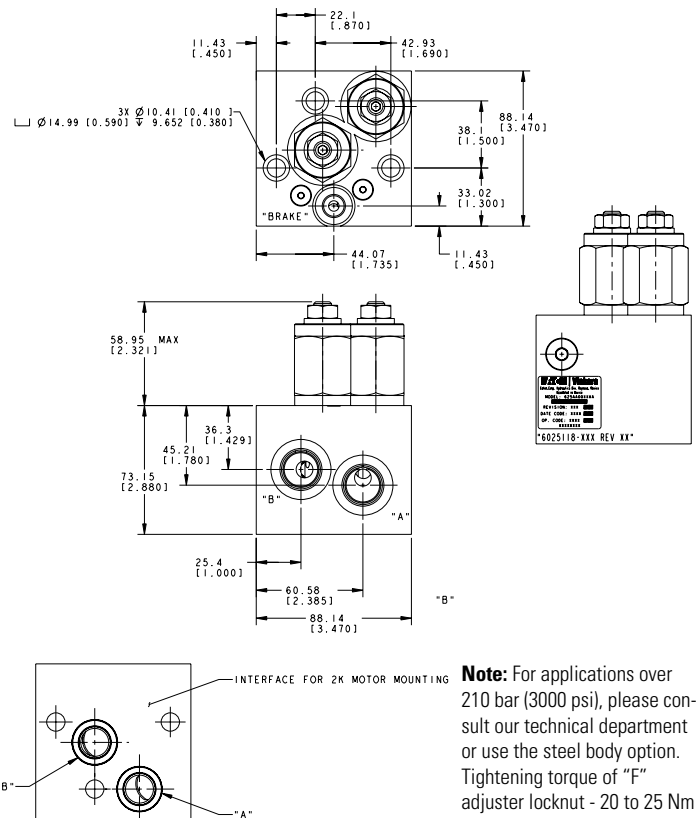

Note: For applications over 210 bar (3000 psi), please consult our technical department or use the steel body option. Tightening torque of "F" adjuster locknut - 20 to 25 Nm. Check motor mounting compatibility before specifying.

Dual Cross-over Relief Package for 2000 Series Disc Valve Motors

Cartridge valves & manifolds for disc valve motors

Dual Crossover Relief Valve Assembly

This valve assembly provides motor over-pressure protection in both directions of rotation, while supplying the return or lower pressure side of the motor with makeup oil. If closed center valving is used, an additional function is controlled braking.

Typical applications are vehicle propulsion and motor work circuits in which pressure limiting is required.

How to Order

Complete pre-assembled packages are specified using the RV3A-10 model code. Option "A" must be selected for the cage seals, position 6 of the model code is

"2K". To order the manifold separately, without the two RV3A cartridges, order 4997060-001

RATINGS AND SPECIFICATIONS

Rated flow	76 L/min(20USgpm)
Rated pressure	210 bar (3000psi)
Internal leakage (maximum)	less than 5 drops/min @ 85% of nominal setting
Manifold sub-assembly only	4997060-001
Installation kit (includes cap screws, washers and o-rings)	02-372492

For detailed specifications refer to the RV3A-10 data sheet.

Dimensions

mm (inch)

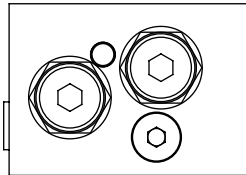

Port Sizes

"A", "B" – SAE10
"Brake" – SAE4



Warning

This manifold package may not be suitable for application with all 2000 series motors - please check installation dimensions carefully.

Functional Symbol

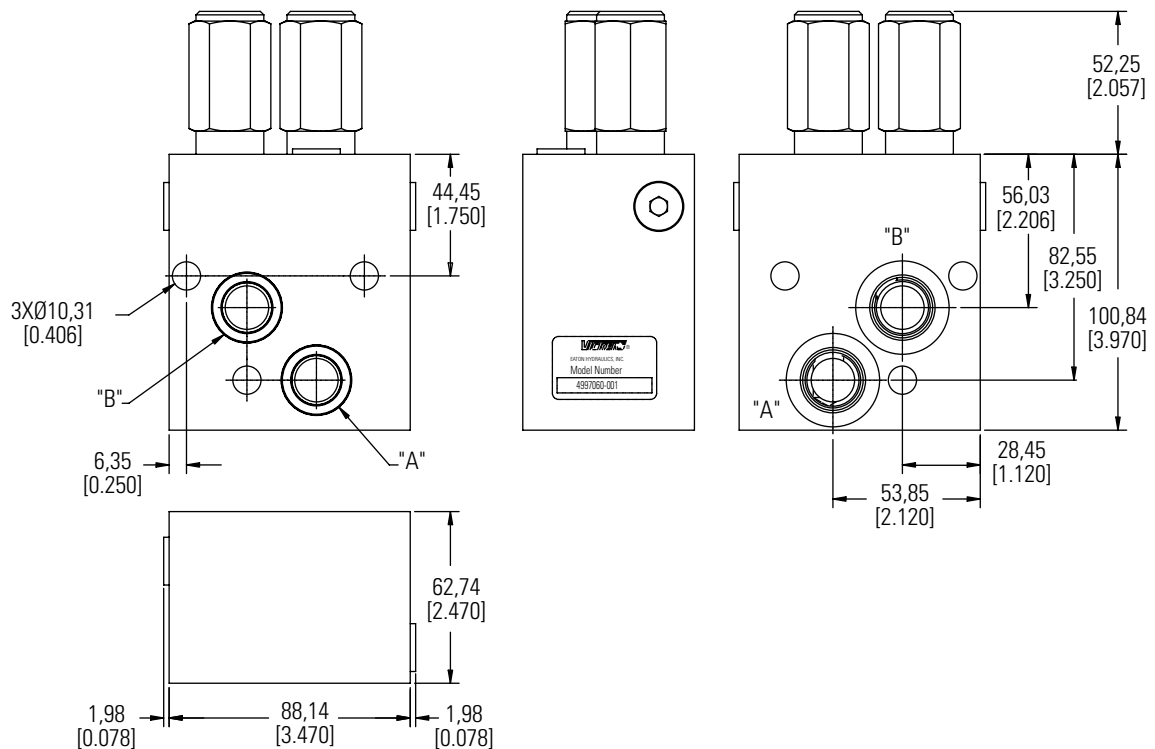
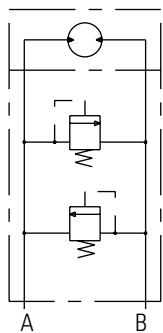

ATEX Certification

This option is available on H,S,T, 2000 series, 4000 series, 4000 Compact series, 6000 series, 10,000 series, VIS 40, VIS 45 and HP 30 Motors



What is ATEX Certification?

ATEX certification is a certification that allows our motors to be used in certain types of explosive environments. It derives its name from the French title of the European Union ATEX directive - ATmosphèresEXplosives.

Benefits

ATEX certification on our motors allows our motors to be used in certain types of explosive environments. When you order an ATEX certified motor, you receive:

- An ATEX certified motor that has the ATEX marking on the label.
- An operating instructions manual
- EC Declaration of Conformity (ATEX Certificate)

Applications

As mentioned above, it can be any application that operates in explosive environments. Typically, this includes Oil and Gas applications, Mining applications and applications in the rubber industry.

How to configure an ATEX certified Motor in the model code?

To specify an ATEX certified motor, you will need to select the 'EX' option from the Special features (Hardware) section of the model code for the above motors.

Fluids Recommendations

Product Line	Viscosity Minimum	Viscosity Best Range	ISO Cleanliness Requirements
J-2, S, W, T Series	70 SUS 13 cst	100-200 SUS 20-43 cst	20/18/13
H Series	100 SUS 20 cst	100-200 SUS 20-43 cst	20/18/13
Disc Values Series	70 SUS 13 cst	100-200 SUS 20-43 cst	20/18/13
VIS Series	70 SUS 13 cst	100-200 SUS 20-43 cst	20/18/13

Introduction

Hydraulic fluids are one of the vital components of hydraulic system. Proper selection of oil assures satisfactory life and operation of system components. The purpose of this section is to provide readers with the knowledge required to select the appropriate fluids for use in systems that employ Eaton hydraulic components.

Viscosity and Temperature

Viscosity is the measure of a fluid's resistance to flow. The most important characteristic to consider when choosing a fluid to be used in a hydraulic system is viscosity. The fluid must be thin enough to flow easily but thick enough to maintain adequate lubricating film between component and to maintain proper sealing at the operating temperatures of the hydraulic system. For viscosity requirements see table. Viscosity of any fluid is relative to temperature, as the fluid warms the viscosity decreases and vice versa. When choosing a fluid, it is important to consider the start-up and operating temperatures of the hydraulic system. A high VI fluid shows relatively small change of viscosity with temperature. Lubricants used for hydraulic applications may contain viscosity index improvers (VII). They refer to these fluids as viscosity index improved, or multi-viscosity fluids. The viscosity of these fluids may drop down in use due to the shearing of VI improvers used in the

formulations. Anti-wear hydraulic oils containing polymeric thickeners (Viscosity Index Improvers [VII]) are generally used for wide band operating temperature applications. These fluids experience temporary and permanent viscosity loss during use in hydraulic system. Check the extent of viscosity loss (shear stability) to avoid hydraulic service below the recommended minimum viscosity. Oil with good shear stability is recommended for wide band temperature applications. Multi-grade engine oils, ATFs, UTTOs, etc., also contain VIIs, and viscosity loss will be encountered during use.

Cleanliness

Cleanliness of the fluid in a hydraulic system is extremely important. More than 70% of all failures are caused by contamination. Eaton recommends that the fluids used in its hydraulic components be maintained per ISO 4406. Cleanliness level requirements varies with the hydraulic components. The cleanliness of a hydraulic system is dictated by the cleanliness requirement of the most stringent component in the system. Cleanliness requirements for specific products are given in the table. OEMs and distributors who use Eaton hydraulic components in their products should provide for these requirements in their design. A reputable filter supplier can supply filter information.

Fluid Maintenance

The condition of a fluid has a direct effect on the performance and reliability of the system. Maintaining proper fluid viscosity, cleanliness level, water content, and additive level is essential for excellent hydraulic system performance. Routine fluid condition monitoring is recommended.

Fluid Selection

Premium grade anti-wear (AW) petroleum based hydraulic fluids will provide the best performance in Eaton hydraulic components. Lubricants that pass Eaton Vickers® 35VQ25A high-pressure vane pump test (Eaton ATS-373 test procedure, ASTM Specification D-6973) are considered good quality, anti-wear hydraulic fluids. Automotive crankcase oils with American Petroleum Institute (API) letter designation SE, SF, SG, SH, or higher per SAE J183 classes of oils are recommended for applications using Eaton GG motors. Automotive crankcase oils generally exhibit less shear stability compared to industrial anti-wear hydraulic fluids, which can result in higher loss of viscosity during service life. Other mineral oil-based lubricants commonly used in hydraulic systems are automatic transmission fluids (ATFs) and universal tractor transmission oils (UTTOs). Synthetic hydrocarbon base stocks, such as polyalphaolefins (PAOs), are also

used to formulate hydraulic fluids, engine oils, ATFs and UTTOs. Alternative fluids are recommended when specific properties, such as fire resistance, biodegradability, etc., are necessary for the application. Keep in mind that alternative fluids may differ from AW petroleum fluids in properties such as pressure viscosity coefficient, specific gravity, lubricity, etc. Hence, GG motors may need to be derated, some can be operated under full ratings, and other are not rated.

Additional Notes:

When choosing a hydraulic fluid, all the components in the system must be considered. Viscosity limitations has to meet the most stringent components requirements. For any system where the fluid is non petroleum oil, set the target one ISO range code cleaner for each particle size, than that of petroleum fluids. Keep adequate fluid level in the reservoir. Take fluid level reading when the system is cold. For more details, refer to Eaton Fluid Recommendation Document # 03-401-2010

Contact your Eaton representative if you have specific questions about the fluid requirements of Eaton hydraulic components.

