

Heat Reclaim in Transcritical CO₂ Systems

General description

When using CO₂ as refrigerant the critical point is reached already at 31 °C (74 bar). At temperatures and pressures above this point there is no relationship between pressure and temperature (not tied together as seen in the sub critical refrigeration process) why temperature and pressure can be controlled individually. In this condition there are no phase changes and no liquid is present but the mixture is best described as a gas. Compressor discharge temperatures between 80 and 120 °C are typical reached and furthermore in the transcritical refrigeration condition it's possible to reclaim most of the energy normally rejected by a gas cooler.

These unique features are utilised when reclaiming heat that is normally rejected or wasted by an air cooled gas cooler.

To be able to reclaim heat, one or two heat exchangers are mounted before the gas cooler. To ensure robust refrigeration process a superior control strategy is crucial to control pressure as well as temperature when reclaiming heat to avoid condensation of liquid in the heat exchangers and to avoid risk of liquid hammering. Also it's important that the minimum temperature out of the gas cooler is at least 3 K higher than the receiver pressure (converted to temperature) to avoid condensation of gas in the receiver if cold liquid should be entering and thereby causing too low receiver pressure.

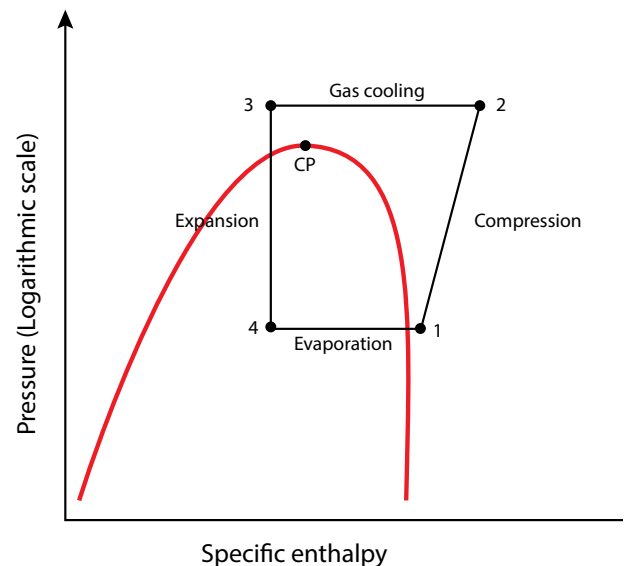
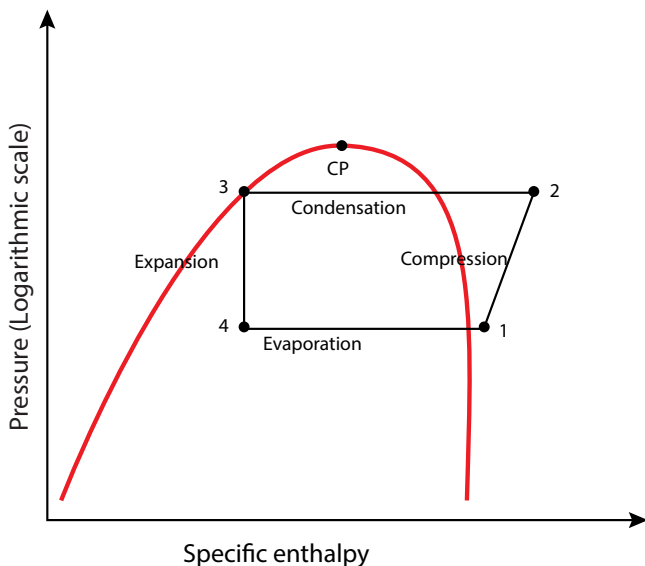

Difference between a subcritical and transcritical refrigeration process

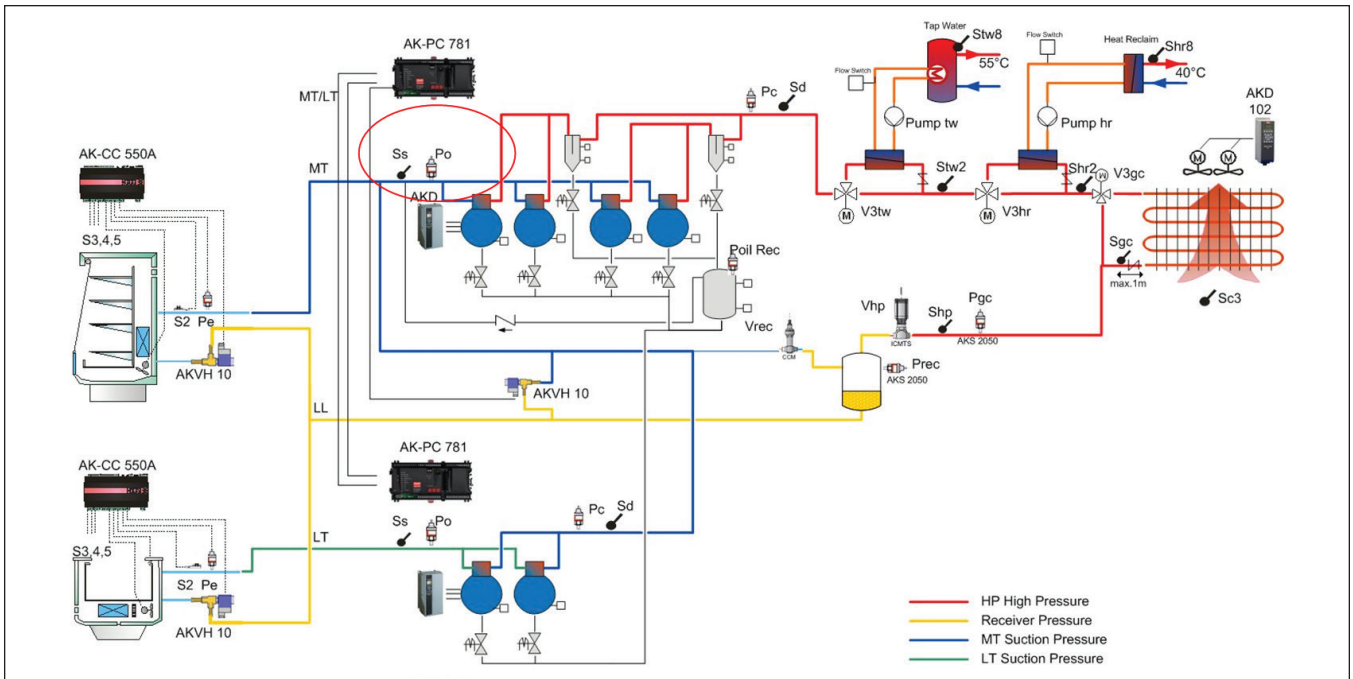

Efficient heat reclaim with CO₂

In theory all the heat rejected from a refrigeration process can be reclaimed. In a supermarket application this is typical all the heat removed from refrigerated display cases and cold rooms in addition to the electricity used by the compressors. Lets say the refrigeration capacity is 3 KW with a COP of 3 then the heat rejected would be 3 KW +1 KW compressor load equal 4 KW which as a rule of thumb could be reclaimed. Unfortunately the load of the refrigeration system is typical low in cold periods where there is a high load on the heating system, never the less it makes sense to reclaim heat especially for hot tap water where the consumption is normally constant throughout the year.

By using CO₂ as refrigerant it's attractive to invest in heat reclaim because of the high discharge temperatures (often 100 – 120 °C) and the high enthalpy compared to traditionally used HFC refrigerants meaning that a bigger part of the rejected heat (energy) can be reclaimed or more heat can be reclaimed at a higher efficiency compared to other traditional HFC refrigerants.

When using CO₂ for MT refrigeration it's possible to work with condensing temperatures down to 5 °C. As dimensioning criteria the minimum temperature out of the gas cooler is often set as low as 5 to 8 °C and minimum pressure in the gas cooler is typical set around 40 to 45 bar to ensure a receiver pressure to be kept at 35 to 40 bar to maintain sufficient pressure differential across the expansion valves in the display cases.

Heat reclaim without compromising COP

In practical the discharge temperature on the high temperature pack in a CO₂ trans-critical booster system, is typically above 55 °C even at winter conditions. With above mentioned design criteria it's possible to reclaim heat for hot tap water without increasing pressure making it possible to reclaim heat at highest possible refrigeration COP. The higher the ambient temperature is, the more heat can be reclaimed without compromising the refrigeration COP.

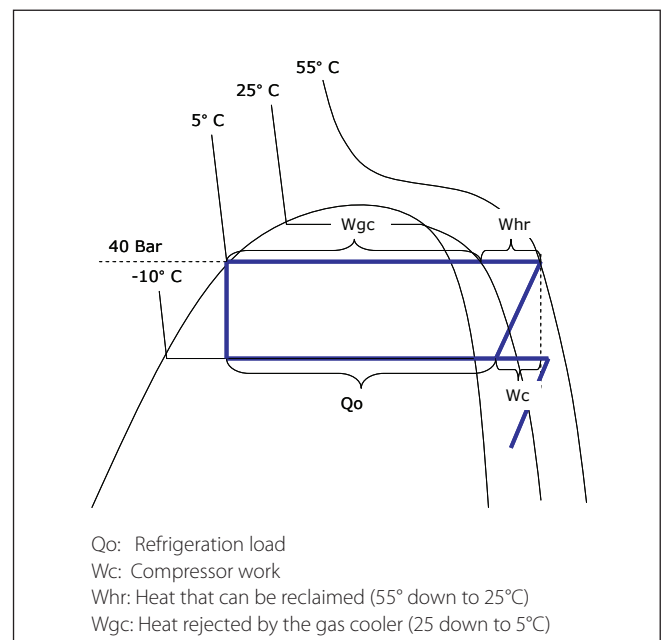

Transcritical booster system running at winter condition (subcritical condition).

Increasing pressure in the gas cooler

If more heat is needed eg. for floor heating it's possible to increase the pressure in the gas cooler which will increase the compressor work but as the COP is typical between 2 and 7 depending on running conditions, heat reclaim is often an attractive heat source compared to other heat sources even at winter time.

What can be seen is that by only adding a limited extra compressor work "Wchr" its suddenly possible to reclaim around 80 % of heat Whr2" (100 down to 25 °C), and only around 20 % is typically not possible to reclaim as the temperature of the gas is below 25 °C.

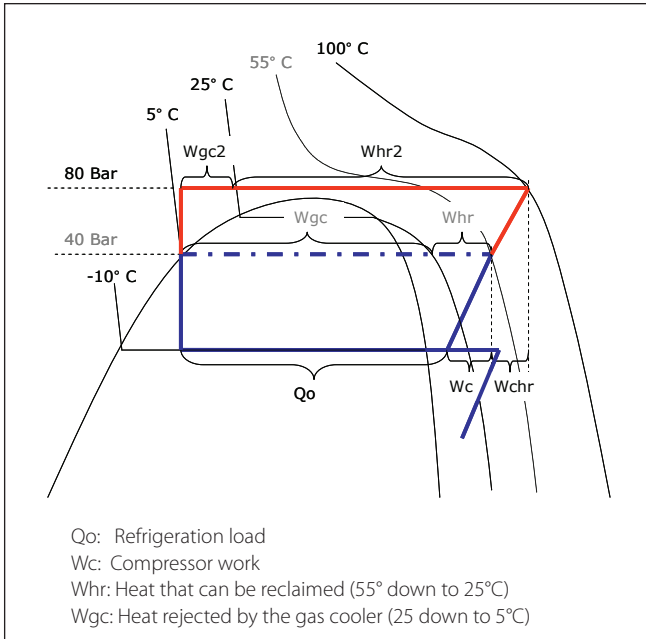

The high pressure has been increased to 80 bar (transcritical condition).

By passing the gas cooler – 100 % heat reclaim

To be able to reclaim the last part of the heat rejected through the gas cooler, the gas cooler has to be bypassed. Since it's typically not possible to reclaim at a lower temperature than 25 °C (to maintain 20° inside a supermarket) the gas temperature should then be lifted from 5 – 25 °C (at low ambient temperatures only) resulting in lower Qo. To maintain same Qo more compressor capacity would be needed again resulting in a lower COP but with the possibility to reclaim 100% of the generated heat from 100°C down to 25 °C.

When bypassing the gas cooler, the gas temperature is lifted from 5 °C (at low ambient temperatures only) to 25 °C to be able to reclaim 100 % of the heat "Whr3" generated by the refrigeration system. To compensate for the reduced Qo "Qo3" a higher refrigerant mass flow is required resulting in more compressor capacity or longer compressor run time is needed.

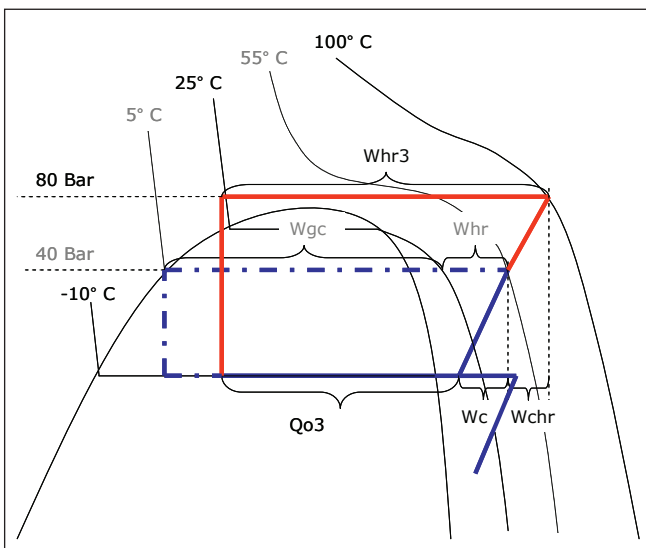

Same process but the gas cooler has been bypassed.

Arguments for heat reclaim with CO₂

Even in wintertime where the system is running in subcritical condition, sufficient heat is normally available to reclaim for hot tap water without increasing pressure in the gas cooler.

If more heat is needed the pressure in the gas cooler can be increased. When passing into the transcritical condition there is suddenly a lot more heat available for heat reclaim with only a limited amount of extra compressor work.

Occasionally 100 % heat reclaim from the refrigeration system would be sufficient heat source to fulfil the heating and hot tap water demand in a supermarket, making it possible to save investment and running cost for other heat sources, all depending on load conditions and cost of alternative heat sources. Reclaiming the last part is not very efficient why the cost has to be judged against alternative heat sources.

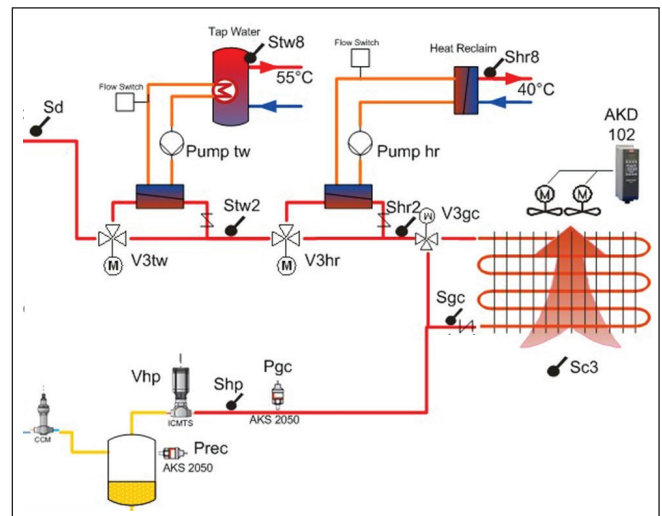

Heat reclaim with AK-PC 781

The integrated heat reclaim function in AK-PC 781 is able to control the heating temperature in up to two independent circuits, one typically used for hot tap water and a second circuit typically used for room heating at a lower temperature

level. It's possible to select hot tap water only, heat reclaim for heating purpose only, or both together (selection between "None", "Tap water", "Heat reclaim", "Tap and heat", in the service tool).

If heat reclaim is setup but no heat reclaim is requested, then the controller will bypass the heat exchangers by means of the valves "V3tw" / "V3hr" and the pumps "Pump tw" / "Pump hr" will be stopped. If no heat reclaim is requested the refrigeration process is controlled at lowest possible gas temperature "Sgc" depending on ambient temperature "Sc3" and optimum high pressure "Pgc" to ensure optimum COP of the refrigeration process.

Safety functions

A number of safety functions have been integrated to ensure proper refrigeration of food and trouble free operation. These features request that all shown sensors have to be mounted to be able to activate heat reclaim.

Boiling water protection:

At 95 °C measured at any sensors in the water circuits, heat reclaim will be disabled in the specific circuit.

Too low discharge "Sd" temperature:

If "Sd" is measured lower then the return temperature in the water circuit "Stw3"/"Shr3" Heat reclaim will be disabled / can not be activated for the specific circuit.

Broken temperature sensors:

If any of the temperature sensors in a specific heat reclaim circuit is broken or not available, Heat reclaim will be disabled / can not be activated for the specific circuit.

Too low gas temperature:

If the gas temperature out of the heat exchangers "Stw2"/"Shr2" is too low the Heat reclaim will be disabled for the specific circuit.

No water flow:

If flow switch is available (optional in setup) the flow switch has to be active for a defined delay time when pumps are running (eg. 30 sec.) before the heat reclaim can be activated. If flow signal is lost while pumps are running the heat reclaim will be deactivated after the defined delay time.

Heat reclaim for hot tap water

The overall control sensor for hot tap water heat reclaim is "Stw8" and a reference can be set for the hot tap water temperature eg. 55 °C. A thermostat band eg. 5 °C is placed around the reference, starting the heat reclaim at eg. 52,5 °C and stopping the heat reclaim at 57,5 °C.

To avoid too frequently stat/stop of hot water heat reclaim it's possible to mount a second temperature sensor at a lower level in the hot water boiler using two sensors "Stw8" and "Stw8a" for the thermostat function. If temperature measured at the upper sensor "Stw8" is equal or lower than ex. 52,5 °C the heat reclaim function is started but will first be stopped when the water temperature at the lower sensor "Stw8a" has reached ex. 57,5 °C.

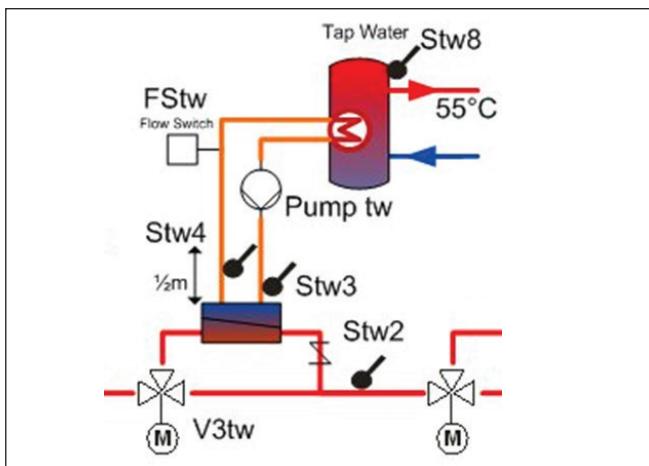

It's possible to choose between three different control strategies/control sensors:

- Based on delta T between "Stw4" and "Stw3". The pump can only be variable speed controlled where a reference for the "delta T" (Stw4-Stw3) has to be set. Kp and Tn can be set for the PI control loop as well as min. and max. speed for the pump.
- Based on reference and thermostat band for Stw8. The pump can now be operated in two different ways:
 - On/off based on reference and thermostat band.
 - Variable speed (0-10 V) based on reference for Stw8. Kp and Tn can be set for the PI control loop as well as min and max speed for the pump.
- Based on reference for the combination of Stw8 and Stw8a. The pump can only be on/off controlled following the cut in measured with Stw8 and cut out measured with Stw8a.

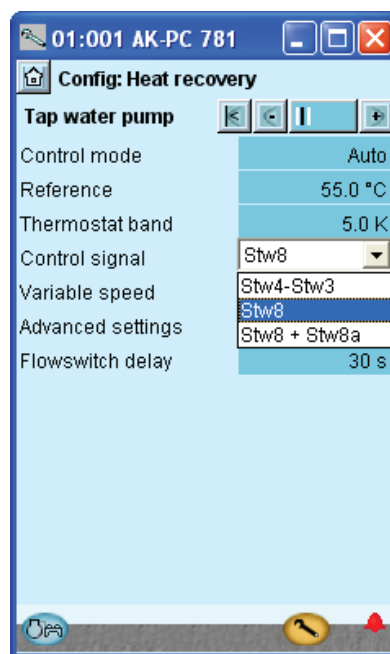

It's not possible to force the gas pressure to a defined minimum limit while reclaiming through the hot tap water circuit. If increase of the pressure is requested for tap water the Heat reclaim circuit for heating purpose could be used also for tap water.

Heat reclaim for heating purpose

For supermarket applications there is typically more heat to reclaim as needed for hot tap water, why it makes sense to invest in heat reclaim for heating purpose ex floor heating or pre heaters in ventilation systems.

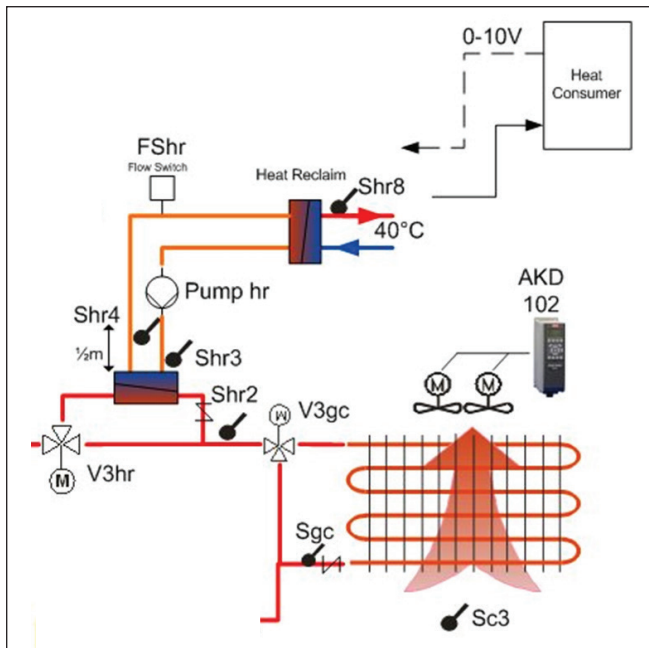

The heat reclaim for heating purpose can be set in three different modes:

No HP-Offset

When this mode is selected the functionality is very similar to hot tap water heat reclaim where the pressure is kept as low as possible according to ambient temperature.

HP-Offset

At low ambient temperatures it could be necessary to increase the pressure in the gas cooler to enable more energy for heat reclaim. A minimum pressure (Pgc HR min) can now be defined when reclaiming with the option of external override from up to 5 external heat consumers. The heat consumer with the highest demand (measured with 0-10 V analogue inputs) will drive the pressure increase to the set Pgc HR offset. Eg. $49 + 30 = 79$ bar at 10 volt

Max heat reclaim

In applications where 100% heat reclaim is requested it's possible to bypass the gas cooler by the valve "V3gc" which has to be enabled in advanced settings within configuration of HP control.

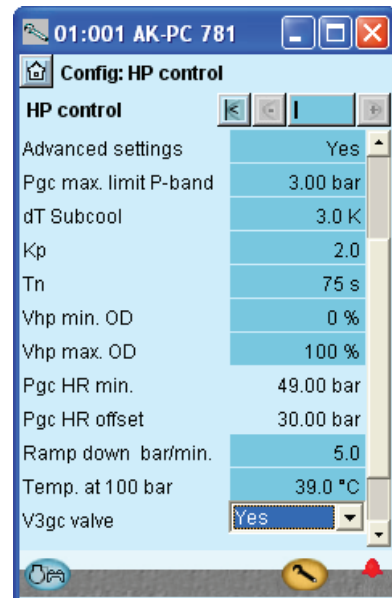
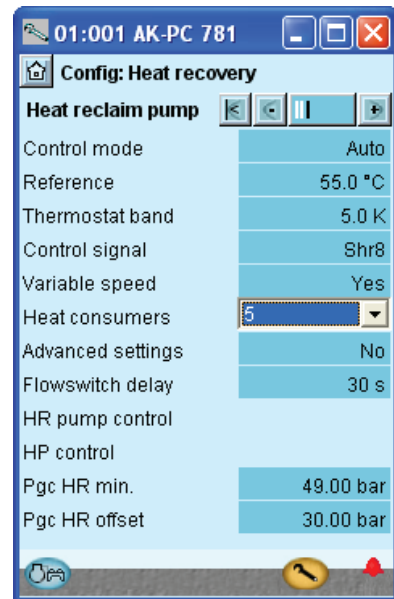

Based on the highest override signal (0 – 10 V) from up to 5 external heat consumers the function takes place in a sequence of 4 steps:

1. Start of heat reclaim where the pressure will be increased to the minimum defined limit.
2. The gas cooler pressure will be lifted to the maximum offset.
3. The reference for the gas cooler fans (reference is calculated by the controller) is increased to reduce fan capacity.
4. Gas cooler is bypassed.

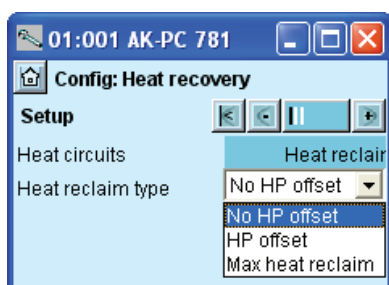

It's possible to choose between three different control strategies / sensors giving different possibilities for control of the pump "Pump hr":

- Based on delta T between "Shr4" and "Shr3" The pump can only be variable speed controlled where a reference for the "Delta T" (Shr4 – Shr3) has to be set. KP and Tn can be set for the PI controller as well as min. and max. speed for the pump.
- Based on reference and thermostat band for Shr8. The pump can now be operated in two different ways:
 - On/Off based on reference and thermostat band
 - Variable speed control (0 – 10 V) based on reference for Shr8. KP and Tn can be set for the PI controller as well as min. and max. speed for the pump.
- Based on constant water temperature Shr4 The pump can only be variable speed controlled where the "Reference" is target for Shr4. The "Thermostat band" is still used to start or stop the heat reclaim. KP and Tn can be set for the PI controller as well as min. and max. speed for the pump.

Summing up

The AK-PC 781 pack controller offer a number of integrated features especially developed for transcritical CO₂ booster systems:

- COP optimised gas pressure control
- Receiver and gas by pass control
- Variable speed control of lead compressor and gas cooler fans
- Oil management functions
- Advanced heat reclaim for tap water and heating purpose.

By integrating all control functions it has been possible to control a transcritical pack with the highest possible COP at all load conditions. Next to safety the quality of refrigerated food has highest priority why a number of build in override and safety functions secure optimum control of the refrigeration system. Requested amount of heat reclaimed is automatically controlled as long as the refrigeration load is satisfied, and integrated control functions will automatically disable a heat reclaim circuit in case too much heat is retrieved usually causing loss of refrigeration capacity.

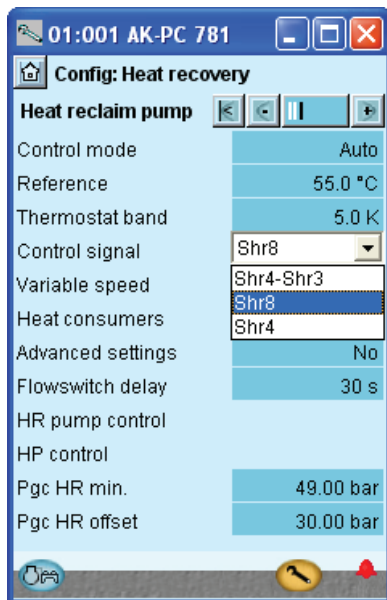

Control sensor

If Shr8 or Delta T (Shr4 – Shr3) is used as control signal the overall heat reclaim control sensor for heating purpose is "Shr8" and a reference can be set for the requested water temperature eg. 40 °C. A thermostat band eg. 5 °C is placed around the reference, starting the heat reclaim at eg. 37,5 °C and stopping the heat reclaim at 42,5 °C.

If Shr4 is selected as control signal (controlling of constant water temperature to heat consumers) the overall control sensor for the heat reclaim is Shr4 and the Shr8 is used for monitoring purpose only.