



Capacity controller EKC 331

Introduction

Application

The controller is used for capacity regulation of compressors or condensers in small refrigerating systems.

Advantages

- Patented neutral zone regulation
- Sequential or cyclic operation

Functions

- Regulation
Regulation with up to four relay outputs can be carried out. Regulation takes place with a set reference which is compared to a signal from a pressure transmitter.
- Relay module
It is possible to use the controller as relay module, so that the relays are cut in or out by means of an external voltage signal.
- Alarmfunction
A relay becomes activated when the set alarm limits are exceeded.
- Digital input
The digital input can be used for:
 - night operation where the suction pressure is raised
 - heat recovery where the condensing pressure is raised
 - external start/stop of the regulation.

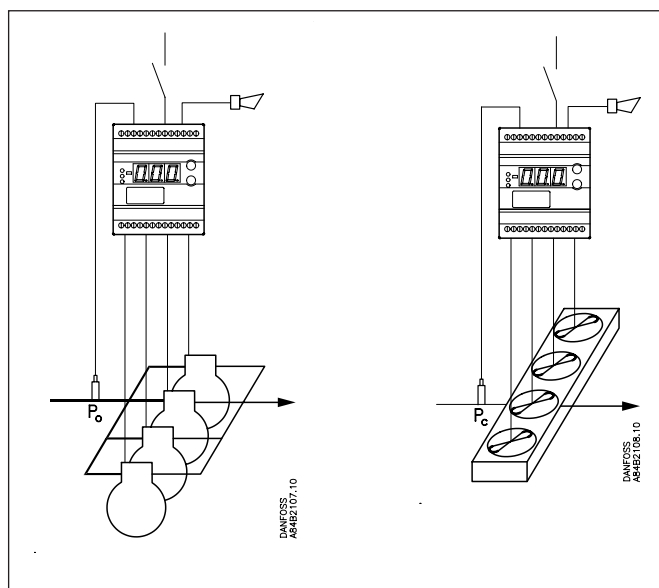

Function

Capacity regulation

The cut-in capacity is controlled by signals from the connected pressure transmitter and the set reference. Outside the reference a neutral zone is set where the capacity will neither be cut in nor out. Outside the neutral zone (in the hatched areas named +zone and -zone) the capacity will be cut in or out if the regulation registers a change of pressure "away" from the neutral zone. Cutin and cutout will take place with the set time delays. If the pressure however "approaches" the neutral zone, the controller will make no changes of the cut-in capacity. The size of the +zone and -zone is identical and defined to be constantly 0.7 times the set value of the neutral zone. If regulation takes place outside the hatched area (named ++zone and --zone), changes of the cut-in capacity will occur somewhat faster than if it were in the hatched area. The set time delays will here be reduced by factor 0.3. Cutin of steps can be defined for either sequential or cyclic operation.

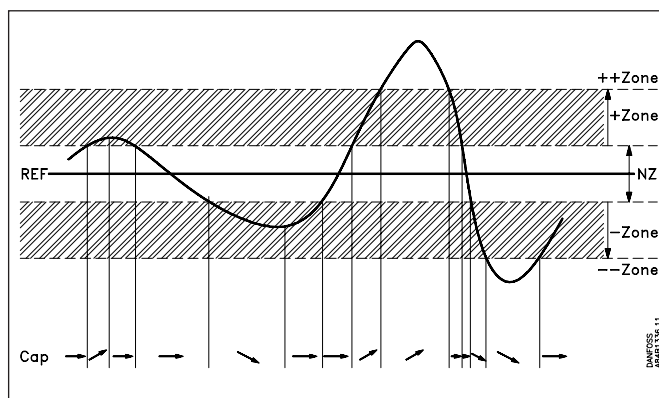

Relay module

The controller can also be used as a relay module where the relays in the module will then be controlled by the received voltage signal. Depending on the definition of the signal and the number of relays used, the relays will be "distributed" over the signal. A hysteresis around the individual cutin and cutout points will ensure that the relay will not cut in or out when it is not called for.

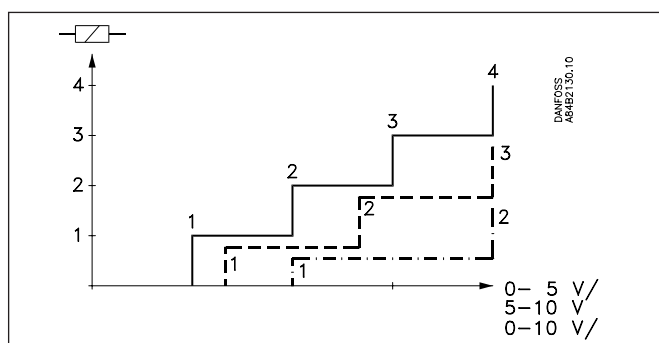

Survey of functions

Function	Parameter	Parameter by operation via data communication
Normal display		
Normally the signal from the pressure transmitter is shown. If the controller is used as relay module, U_{in} will appear on the display.		Pressure
Pressure regulation		Reference
Regulation reference Regulation is based on the set value. (Push both buttons simultaneously to set the menu.)	-	Press. set point
Neutral zone There is a neutral zone around the reference. See also page 2.	r01	Neutral zone
Displacement of reference The set reference may be displaced with a fixed value when a signal is received at the DI input. Regulation will then be based on the set reference plus the value set here. The total reference can be seen when you push the lower of the two buttons. (Cf. also Definition of DI input).	r13	Pressure offset
Reference limitation The controller's setting range for the reference can be narrowed down, so that you cannot accidentally set a too high or too low value - that may result in damage to the system. With these settings the reference can only be set between the two values.		
Max. permissible reference value.	r02	Max. set point
Min. permissible reference value.	r03	Min. set point
Pressure unit Here you can select whether the controller is to indicate the pressure in bar or psig. (When psig is selected, the settings must also be in psig).	r05	Unit bar=0 psig=1 (In AKM only bar is used, whatever the setting).
Alarm		Alarm settings
The controller can give alarm in different situations. When there is an alarm all the light-emitting diodes (LED) will flash on the controller front panel, and the alarm relay will cut in.		
Upper deviation Here you set when the alarm at high pressure is to enter into effect. The value is set as an absolute value. See also emergency procedure page 5.	A10	Max. pressure
Lower deviation Here you set when the alarm at low pressure is to enter into effect. The value is set as an absolute value. See also emergency procedure page 5.	A11	Min. pressure
Alarm delay If one of the two limit values is exceeded, a timer function will commence. The alarm will not become active until the set time delay has been passed. The time delay is set in seconds.	A03	Alarm delay
Give the top button a brief push to zeroset the alarm and to have the message shown on the display.		Reset alarm The function zerosets all alarms when set in pos. ON.
		Alarm relay Here you can read the status of the alarm relay. (ON indicates operation with alarm).
		With data communication the importance of the individual alarms can be defined. Setting is carried out in the "Alarm destinations" menu. See also page 8.

Capacity		Capacity
Running time To prevent irregular operation, values have to be set for how the relays are to cut in and out.		
Min. ON time for relays.	c01	Min.ON time
Time delay for cutin of relays.	c05	Step delay inc.
Time delay for cutout of relays.	c06	Step delay dec.
Min. time period between cutin of same relay.	c07	Min recycle time
Coupling Cutin and cutout can take place in three ways: 1. Sequential: First relay 1 cuts in, then relay 2, etc. Cutout takes place in the opposite sequence. 2. Cyclic: An automatic operating time equalisation is arranged here, so that all steps will have the same operating time. (The relay with the fewest number of operating hours cuts in or out before the others). 3. Cyclic with unloader: The function can only be used when there are two compressors with one unloader each. The cyclic operation is performed on relays 1 and 3. The unloaders are mounted on relays 2 and 4 (relays 1 and 2 belong to the first compressor, relays 3 and 4 to the other). The above mentioned "Min. ON time for relays" is not used by the two unloaders. In connection with cutout, the two unloaders are cut out before the compressors are cut out.	c08	Step mode
Unloaders' cutin and cutout mode (Only in connection with cutin/cutout mode 3. See above). The relays for the two unloaders can be set to switch on when more capacity is required (setting = 0), or they can switch off when more capacity is called for (setting = 1).	c09	Unloader (switch on = 0) (switch off = 1)
Miscellaneous		Miscellaneous
External signal Here you set the signal to be connected to the controller. 0: No signal/regulation stopped (display will then show OFF) 1: 4-20 mA from pressure transmitter for compressor regulation 2: 4-20 mA from pressure transmitter for condenser regulation 3: Pressure transmitter type AKS 32R for compressor regulation 4: Pressure transmitter type AKS 32R for condenser regulation 5: 0-10 V from other regulation 6: 0-5 V from other regulation 7: 5-10 V from other regulation	o10	Application mode
Number of relays Depending on the application, up to four relays may be used. This number must be set in the controller. (The relays are always used in numerical sequence).	o19	Number of steps
Pressure transmitter's working range Depending on the pressure, a pressure transmitter with a given working range is used. This working range must be set in the controller (e.g.: -1 to 12 bar).		
Min. value	o20	Min. trans. press
Max. value	o21	Max trans. press
Use of DI input The digital input can be connected to a contact function, and the contact can now be used for one of the following functions: Setting / function: 0: DI input not used 1: Regulation reference displaced when contact is cut in 2: Regulation is started and stopped when the contact is cut in and out, respectively.	o22	Di input control
Operating hours The operating hours for the four relays can be read in the following menus. The read value is multiplied by 10 to obtain the number of hours. On reaching 999 hours the counter stops and must now be reset to, say, 0. There will be no alarm or error message for counter overflow.		(In the AKM display the hour number has not been multiplied)
Value for relay number 1	o23	DO 1 run hour
Value for relay number 2	o24	DO 2 run hour
Value for relay number 3	o25	DO 3 run hour
Value for relay number 4	o26	DO 4 run hour

<p>Manual control From this menu the relays can be cut in and out manually. OFF gives no override, but a number between 1 and 4 will cut in a corresponding number of relays. Cutins and cutouts always take place from relay number 1. When there is manual operation, the display will show "- x". Where x is 0 - 4.</p>	o18	<p>Manual control Only when "Manual control" has been put in pos. ON will it be possible to operate the individual relays. DO relay 1 DO relay 2 DO relay 3 DO relay 4 Alarm relay set When this function is used, the buttons on the controller cannot be used.</p>
<p>Language This setting is only required when data communication has been connected to the controller. Settings: 0=English, 3=Danish. When the controller is operated via data communication, the texts in the right-hand column will be shown in the selected language. When you change the setting to an other language you must activate o04 before "the new language" can be visible from the AKM program.</p>	o11	Language
<p>Frequency Set the net frequency.</p>	o12	Main freq (50=0, 60=1)
<p>Address If the controller is built into a network with data communication, it must have an address, and the master gateway of the data communication must then know this address. These settings can only be made when a data communication module has been mounted in the controller and the installation of the data communication cable has been completed. This installation is mentioned in a separate document "RC.8A.C".</p>		Following installation of a data communication module, the controller can be operated on a par with the other controllers in ADAP-KOOL® refrigeration controls.
The address is set between 1 and 60	o03	
The address is sent to the gateway when the menu is set in pos. ON (The setting will automatically change back to Off after a few seconds.)	o04	
<p>Access code If the settings in the controller are to be protected by a numerical code, you can set a numerical value between 0 and 100. If not, you can cancel the function with setting OFF.</p>	o05	
Operating status		
The controller goes through some regulating situations where it is just waiting for the next point of the regulation. To make these "why is nothing happening" situations visible, you can see an operating status on the display. Push briefly (1s) the upper button. If there is a status code, it will be shown on the display. The individual status codes have the following meanings:		EKC state (0 = regulation)
S2: When the relay is operated, it must be activated for min. x minutes		2
S5: Renewed cutin of the same relay must not take place more often than every x minutes		5
S8: The next relay must not cut in until x minutes have elapsed		8
S9: The next relay must not cut out until x minutes have elapsed		9

Emergency procedure

If the controller registers irregularities in the registered signals, it will start an emergency procedure:

For compressor regulation:

- If the signal from the pressure transmitter becomes smaller than expected, the controller will continue operating with the average capacity that has been cut in during the past 60 minutes. This cut-in capacity will gradually decline as time passes.
- If the signal for the suction pressure becomes smaller than the set value of A11, the capacity will instantly be cut out.

For condenser regulation:

- If the signal from the pressure transmitter becomes smaller than expected, or if the condensing pressure becomes bigger than the set value of A10, the entire capacity will instantly be cut in.

Operation

Display

The values will be shown with three digits, and with a setting you can determine whether the pressure are to be shown in bar or in psig.

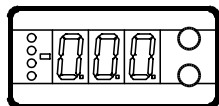

Light-emitting diodes (LED) on front panel

There are four LED's on the front panel which will light up when the relays are operated.

All LED's will flash if there is an error in the regulation. In this situation you can upload the error code on the display and cancel the alarm by pushing the top button briefly.

The controller can give the following messages:		
E1	Error message	Errors in the controller
E2		Regulation out of range or control signal is defect.
A1	Alarm message	High pressure alarm
A2		Low pressure alarm

The buttons

When you want to change a setting, the two buttons will give you a higher or lower value depending on the button you are pushing. But before you change the value, you must have access to the menu. You obtain this by pushing the upper button for a couple of seconds - you will then enter the column with parameter codes. Find the parameter code you want to change and push the two buttons simultaneously. When you have changed the value, save the new value by once more pushing the two buttons simultaneously.



Gives access to the menu (or cutout an alarm)



Gives access to changes



Saves a change

Examples of operations

Set the regulation's reference

1. Push the two buttons simultaneously
2. Push one of the buttons and select the new value
3. Push both buttons again to conclude the setting

Set one of the other menus

1. Push the upper button until a parameter is shown
2. Push one of the buttons and find the parameter you want to change
3. Push both buttons simultaneously until the parameter value is shown
4. Push one of the buttons and select the new value
5. Push both buttons again to conclude the setting

Menu survey

Function	Parameter	Min.	Max.
Normal display			
Shows the signal from the pressure transmitter	-		bar
Reference			
Set the regulation's pressure reference	-	-1 bar	40 bar
Neutral zone	r01	0,1 bar	5 bar
Max. limitation of pressure setting	r02	-1 bar	40 bar
Min. limitation of pressure setting	r03	-1 bar	40 bar
Select unit (0=bar / 1=psig)	r05	0	1
Reference displacement by signal at DI input	r13	-5 bar	5 bar
Alarm			
Upper alarm limit (absolute value)	A10	-1 bar	40 bar
Lower alarm limit (absolute value)	A11	-1 bar	40 bar
Alarm's time delay	A03	1 s	300 s
Capacity			
Min. ON time for relays	c01	0 s	900 s
Time delay for cutin of relays	c05	5 s	900 s
Time delay for cutout of relays	c06	5 s	900 s
Min. time period between cutins of same relay	c07	0 s	900 s
Definition of regulation mode 1: Sequential 2: Cyclic 3: Cyclic with unloaders	c08	1	3
If the regulation mode 3 has been selected, the relays for the unloaders can be defined to: 0: Cut in when more capacity is required 1: Cut out when more capacity is required	c09	0	1
Miscellaneous			
Controllers address	o03*	1	60
On/off switch (service-pin message)	o04*	-	-
Access code	o05	off(-1)	100
Define input signal and application: 0: no signal / regulation stopped 1: 4-20 mA pressure transmitter - compressor reg. 2: 4-20 mA pressure transmitter - condenser reg. 3: AKS 32R pressure transmitter - compressor reg. 4: AKS 32R pressure transmitter - condenser reg. 5: 0 - 10 V relay module 6: 0 - 5 V relay module 7: 5 - 10 V relay module	o10	0	7
Language (0=english, 3=danish). When you change this setting you must also activate O04.	o11*	0	3
Set supply voltage frequency	o12	50 Hz	60 Hz
Manual operation with "x" relays	o18	0	4
Define number of relay outputs	o19	1	4
Pressure transmitter's working range - min. value	o20	-1 bar	0 bar
Pressure transmitter's working range - max. value	o21	1 bar	40 bar
Define DI input: 0: not used 1: Contact displaces reference 2: Contact starts and stops regulation	o22	0	2
Operating hours of relay 1 (value times 10)	o23	0 h	999 h
Operating hours of relay 2 (value times 10)	o24	0 h	999 h
Operating hours of relay 3 (value times 10)	o25	0 h	999 h
Operating hours of relay 4 (value times 10)	o26	0 h	999 h

*) This setting will only be possible if a data communication module has been installed in the controller.

Factory setting

If you need to return to the factory-set values, it can be done in this way:

- Cut out the supply voltage to the controller
- Keep both buttons depressed at the same time as you reconnect the supply voltage

Data

Supply voltage	230 V a.c. +/-15% 50/60 Hz, 5 VA	
Input signal	Pressure transmitter*) with 4-20 mA or voltage signal (0 - 5 V, 0 - 10 V or 5 - 10 V)	
	Digital input to external contact function	
Relay output	4 pcs. SPST	AC-1: 4 A (ohmic) AC-15: 3 A (inductive)
Alarmrelay	1 pcs. SPST	AC-1: 4 A (ohmic) AC-15: 1 A (inductive)
Data communication	Possible to connect a data communication module	
Ambient temperature	During operation	-10 - 55°C
	During transport	-40 - 70°C
Enclosure	IP 20	
Weight	300 g	
Mounting	DIN rail	
Display	LED, 3 digits	
Terminals	max. 2,5 mm ² multicore	
Approvals	EU Low voltage Directive and EMC demands re CE-marking complied with. LVD-tested acc. to EN 60730-1 and EN 60730-2-9 EMC-tested acc. to EN50081-1 and EN 50082-2	

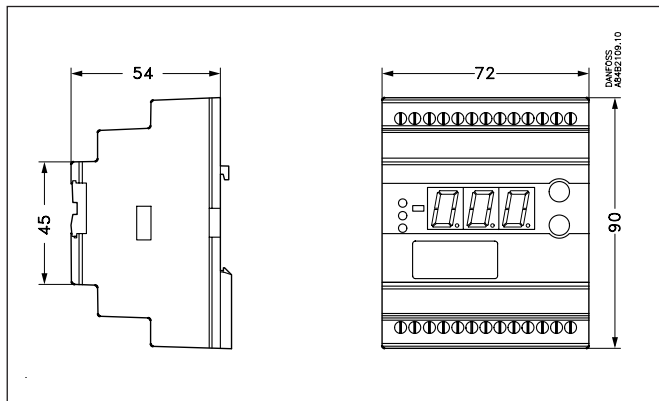

*) Pressure transmitter

As pressure transmitter can be used AKS 3000 or AKS 33 (AKS 33 has a higher accuracy than AKS 3000).

It is also possible to use an AKS 32R. This pressure transmitter is only supplied in large quantities as per arrangement with Danfoss. Please refer to catalogue RK.OY.G...

Ordering

Type	Function	Code No.
EKC 331	Capacity controller	084B7104
EKA 173	Data communication module (accessories), (FTT 10 module)	084B7092
EKA 175	Data communication module (accessories), (RS 485 module)	084B7093

Connections

Necessary connections

Terminals:

25-26 Supply voltage 230 V a.c.

3- 10 Relay connections no. 1, 2, 3 and 4

12-13 Alarm relay

There is connection between 12 and 13 in alarm situations and when the controller is dead

Control signal (see also o10)

Either terminals:

14-16 Voltage signal from AKS 32R

or

17-18 Current signal from AKS 3000 or AKS 33

or

15-16 Voltage signal from an other regulation.

External contact function, if applicable

19-20 Contact function for displacement of reference or start/stop of the regulation.

Data communication, if applicable

21-22 Mount only, if a data communication module has been mounted.

It is important that the installation of the data communication cable be done correctly. Cf. separate literature No. RC.8A.C...

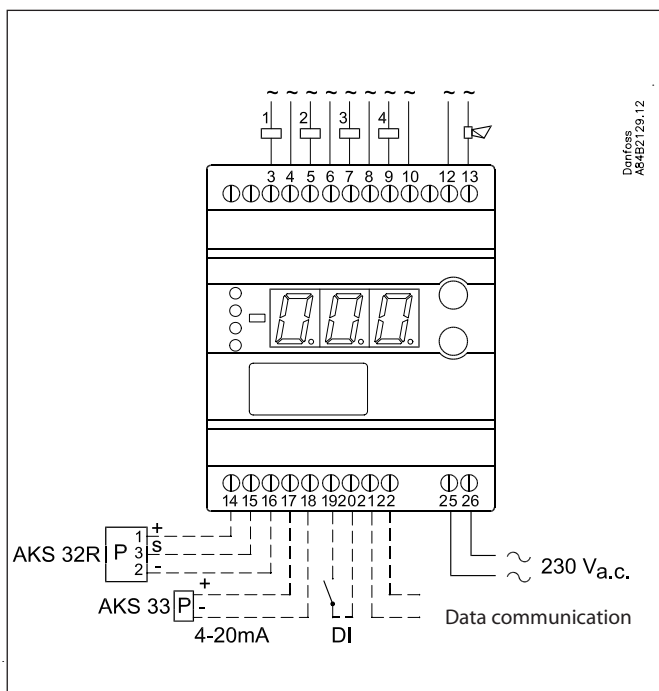

Data communication

This page contains a description of a few of the possibilities you will have when the controller is provided with data communication.

If you want to know more about operation of controllers via PC, you may order additional literature.

Example

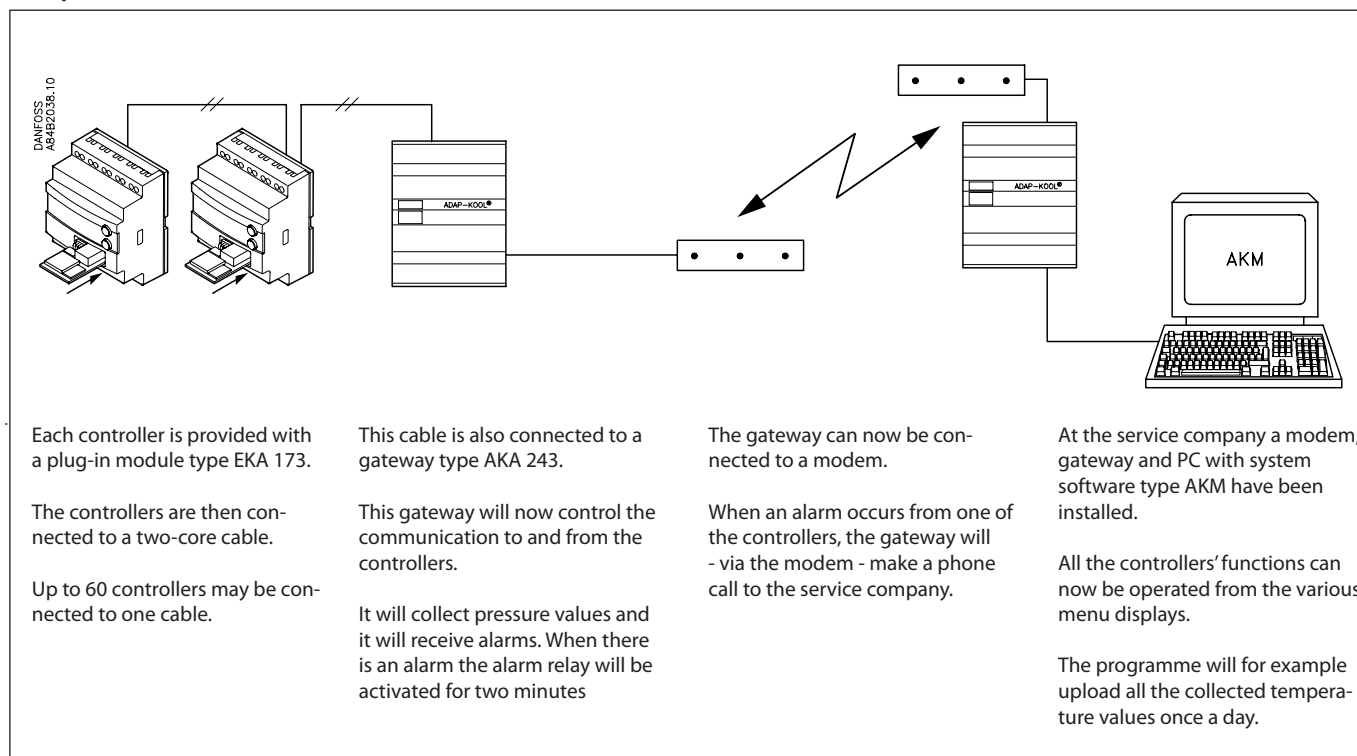

Each controller is provided with a plug-in module type EKA 173.

The controllers are then connected to a two-core cable.

Up to 60 controllers may be connected to one cable.

This cable is also connected to a gateway type AKA 243.

This gateway will now control the communication to and from the controllers.

It will collect pressure values and it will receive alarms. When there is an alarm the alarm relay will be activated for two minutes

The gateway can now be connected to a modem.

When an alarm occurs from one of the controllers, the gateway will - via the modem - make a phone call to the service company.

At the service company a modem, gateway and PC with system software type AKM have been installed.

All the controllers' functions can now be operated from the various menu displays.

The programme will for example upload all the collected temperature values once a day.

Example of menu display

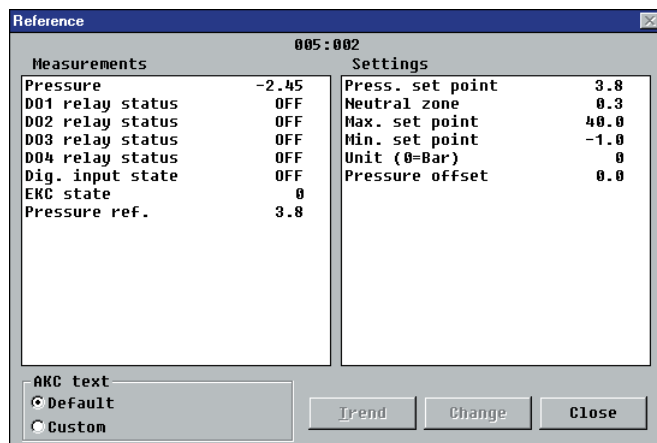

Measurements are shown at one side and settings at the other.

You will also be able to see the parameter names of the functions on page 3 - 5.

With a simple change-over the values can also be shown in a trend diagram.

If you wish to check earlier pressure measurements, you can see them in the log collection.

Alarms

If the controller is extended with data communication, it will be possible to define the importance of the transmitted alarms. The importance is defined with the setting: 1, 2, 3 or 0. When the alarm then arises at some time, it will result in one of the following activities:

1 = Alarm

The alarm message is sent off with alarm status 1. This means that the gateway that is the master in the system will have its alarm relay output activated for two minutes. Later, when the alarm ceases, the alarm text will be retransmitted, but now with status value 0.

2 = Message

The alarm text is transmitted with status value 2. Later, when the "message" lapses, the alarm text is retransmitted, but now with status value 0.

3 = Alarm

As "1", but the master gateway's relay output is not activated.

0 = Suppressed information

The alarm text is stopped at the controller. It is transmitted nowhere.