

Installation guide

Non-return valve (check valve)

ICC 32 and 50



027R9974

027R9974

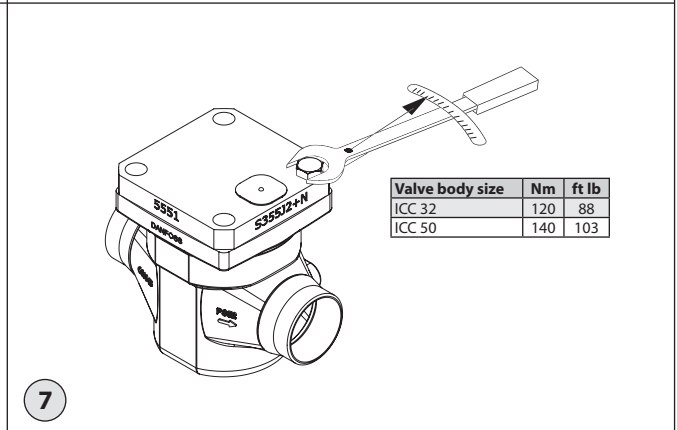
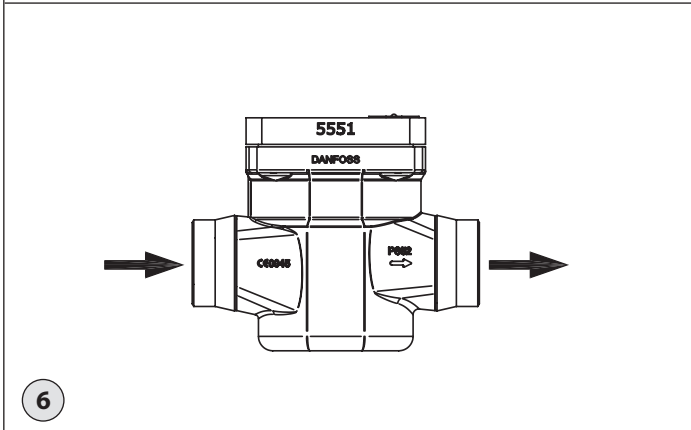
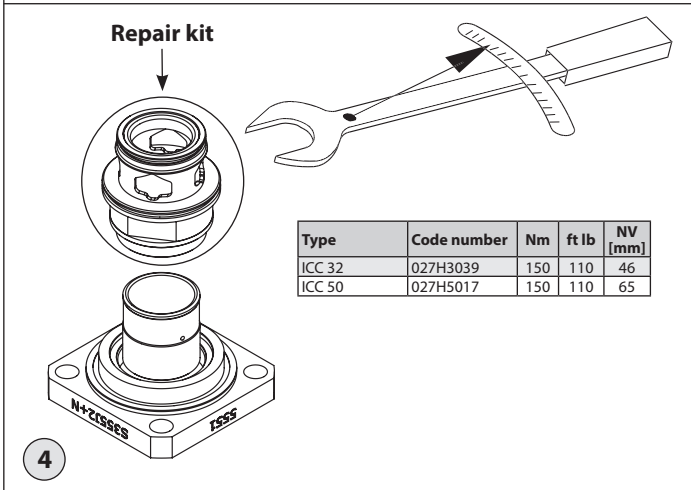
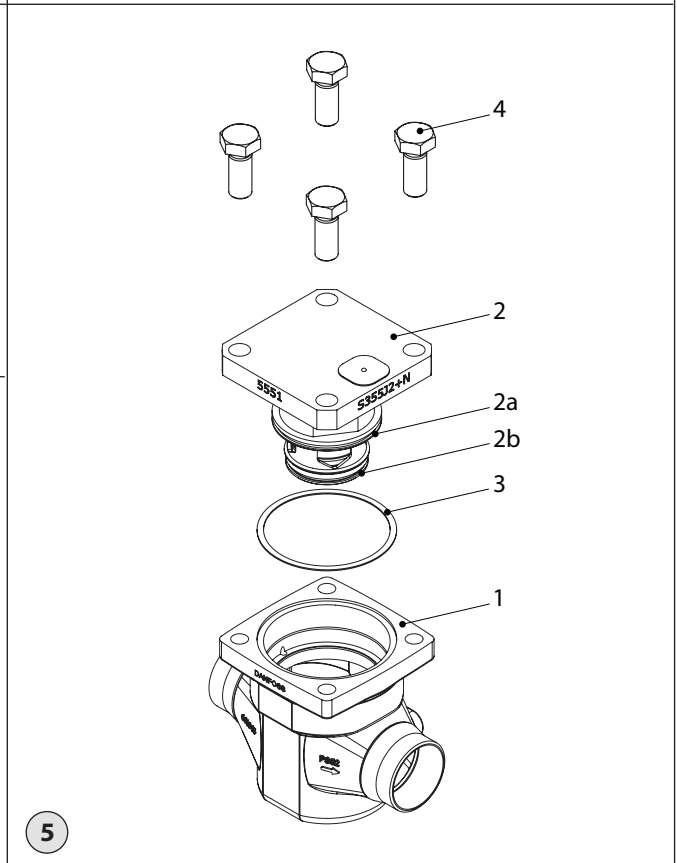
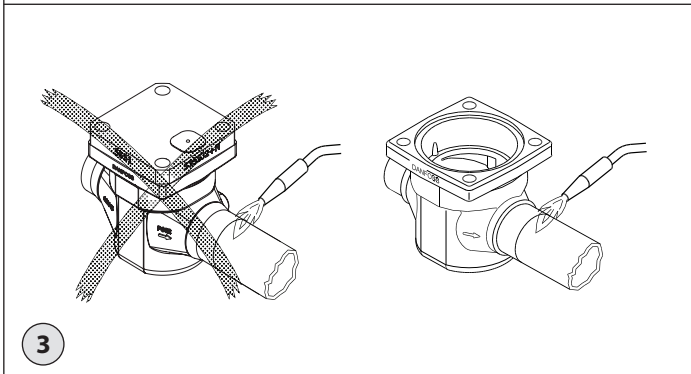
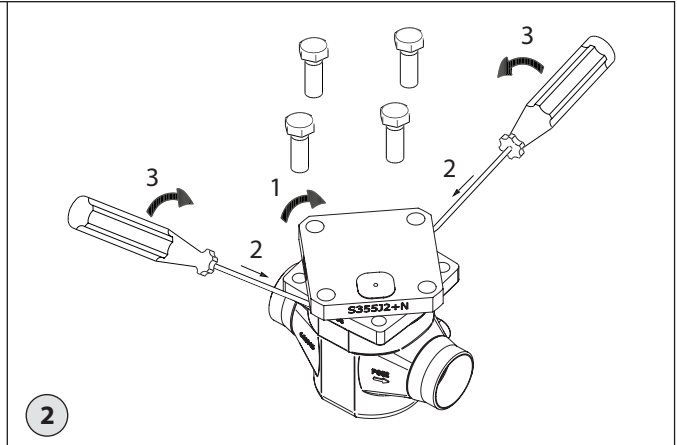
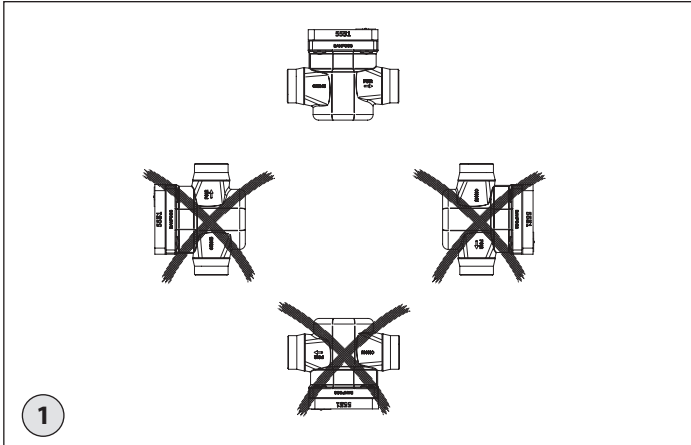

Імпортер: ТОВ з іі "Данфосс ТОВ" 04080, Київ 80, п/с 168, Україна

Info for UK customers only : Danfoss Ltd., 22 Wycombe End, HP9 1NB, GB

ENGLISH

Refrigerants

Applicable to HCFC, HFC, R717 (Ammonia) and R744 (CO₂).
Flammable hydrocarbons are not recommended.
The valve is only recommended for use in closed circuits. For further information please contact Danfoss.

Temperature range

-60/+120 °C (-76/+248 °F)

Pressure range

The valves are designed for a max. working pressure of 52 barg (754 psig).

Technical data

The ICC can be used in Economizer Lines in combination with ICD and ICS. The ICC prevents back pressure flow of the medium in the system.

Regulating range

Dependent on the chosen size.

Opening differential pressure (p)

The ICC main valve requires a minimum opening differential pressure of 0.04 bar (0,6 psi) to begin to open and 0.1 bar (1.45 psi) to be completely open.

Design (fig. 4)

1. Body
2. Top assembly
- 2a O-ring
- 2b O-ring
3. Gasket
4. Bolts

Installation

The valve must be installed with the arrow in the direction of the flow and the top cover upwards (fig. 1 and 6). The top cover can be rotated 4 X 90° in relation to the valve body. The valve is designed to withstand a high internal pressure. However, the piping system should be designed to avoid liquid traps and reduce the risk of hydraulic pressure caused by thermal expansion. It must be ensured that the valve is protected from pressure transients like "liquid hammer" in the system.

Welding (fig. 3 and 5)

The top assembly (fig. 5, pos. 2 and 3) must be removed before welding to prevent damage to o-rings and teflon (PTFE) in the function module and to avoid getting welding debris in the module.

Note: Remove all parts from the valve body before welding (as shown in fig. 3).



In order to maintain the effectiveness of the anti-corrosion treatment, it is important to ensure that the valve is disassembled just prior to the welding / brazing process being undertaken.

In the event that the function modules are to be left disassembled for any length of time, please ensure that the function modules are further protected by placing in a polyethylene bag or by applying a rust protection agent (e.g. refrigeration oil or BRANOROL) on the surfaces.

Danfoss A/S

Climate Solutions • danfoss.com • +45 7488 2222

Only materials and welding methods, compatible with the valve body material, must be welded to the valve body.

The valve should be cleaned internally to remove welding debris on completion of welding and before the valve is reassembled.

Avoid welding debris and dirt in the valve body and the function module. The valve body must be free from stresses (external loads) after installation.

The valves must not be mounted in systems where the outlet side of the valve is open to atmosphere. The outlet side of the valve must always be connected to the system or properly capped off, for example with a welded-on end plate.

Assembly

Remove welding debris and any dirt from pipes and valve body before assembly. Check that the o-rings are intact before replacing the function module. If possible, apply some refrigeration oil to ease the insertion and to protect the o-rings. Check that the top gasket has not been damaged. If the surface has been damaged or the gasket has been bent, it must be replaced.

Tightening (fig. 7)

Tighten the top cover with a torque wrench, to the values indicated in the table.

Colours and identification

The ICC valves are Zinc-Chromated from factory. The Zinc-Chromatization does not cover the welding connections. The valves must be painted. Precise identification of the valve is made via the ID plate on the top cover. The external surface of the valve housing must be protected against corrosion with a suitable top coating after installation involving welding and consequent assembly. Protection of the ID plate when painting the valve is recommended.

Maintenance

Service

The ICC valves are easy to dismantle. Do not open the valve while the valve is still under pressure.

The top assembly module can be lifted out using two screwdrivers as shown fig. 2.

Upon opening and removal of the function module:

- Check that the o-rings on the function module has not been damaged. A valve with a damaged o-ring might not modulate according to the specification.
- Check that the piston and cylinder is free of scratches and look for wear marks. If the wear is excessive the function module should be replaced to prevent unexpected function issues.
- Check that the movement of the cylinder and valve seat is free and with low friction.
- If the teflon valve plate is damaged it must be replaced. A pre-assembled teflon valve plate in cylinder housing is available as repair kit (see also fig. 4):

Type	Code number
ICC 32 repair kit	027H3039
ICC 50 repair kit	027H5017

Assembly

Remove any dirt from the body before the valve is assembled. Check that channel in the valve is not blocked by particles or similar. If possible, apply some refrigeration oil to ease the insertion and to protect the o-rings.

Tightening (fig. 7)

Tighten the top cover with a torque wrench, to the values indicated in the table.



Use only original Danfoss parts, including O-rings and gaskets for replacement. Materials of new parts are certified for the relevant refrigerant.

In cases of doubt, please contact Danfoss.

Drawings are only for illustration, not for dimensioning or construction.

Danfoss accepts no responsibility for errors and omissions. Danfoss Industrial Refrigeration reserves the right to make changes to products and specifications without prior notice.

The following text is applicable to the UL listed products ICC 32 and 50

Applicable to all common non-flammable refrigerants, including R717 and to non-corrosive gases/liquids dependent on sealing material compatibility. The design pressure shall not be less than the value outlined in Sec. 9.2 of ANSI/ASHRAE 15 for the refrigerant used in the system.