

User Guide

Controller to regulate CO₂ gas pressure EKC 326A

ADAP-KOOL® Refrigeration control systems



Introduction

Application

The controller can be used in systems with transcritical and subcritical cooling control systems where CO₂ is used as a refrigerant. The controller regulates the pressure in the gas cooler (condenser) so that the system achieves the optimal COP.

The controller covers the following:

- Transcritical CO₂ refrigeration systems (booster, cascade, high pressure)
- Transcritical CO₂ heat pump systems
- Transcritical CO₂ refrigeration systems with heat recovery
- Transcritical CO₂ chiller systems
- Extra capacity in warm periods. An improvement in the system's cooling performance can be achieved by displacement of the set point ("extra compressor")

Advantages

- Maximum COP
The controller guarantees the system's maximum performance by maintaining the optimal pressure in the gas cooler when regulation takes place in the transcritical range.
- The controller will always optimise to a subcritical state.
- Regulating the receiver pressure based on the receiver pressure reading
- Heat recovery with adjustable reference pressure, 0-10 V
- Optimum heat pump operation

System

The pressure in the gas cooler is controlled by the valve. Regulation must have inputs from both a pressure transmitter PGC and a temperature sensor SGC. Both must be fitted in the outlet immediately after the gas cooler. The valve is an ICMTS valve, which has been specially developed for the pressure conditions that exist in a transcritical CO₂ system. The motor section of the valve is an ICAD actuator and is controlled by a 0-10 V signal from the controller.

If it is necessary to maintain a constant receiver pressure, a valve (ETS, CCM or CCMT) and pressure transmitter (Prec) can be installed. The gas from the receiver bypasses to the inlet side of the high pressure compressor.

Functions

Maximum COP control

The controller maintains optimum pressure in the transcritical range based on a pressure and temperature reading. The reference line is defined with a point at 100 bar. The desired temperature can be set here.

Subcooling

dT subcooling can be used in the subcritical range.

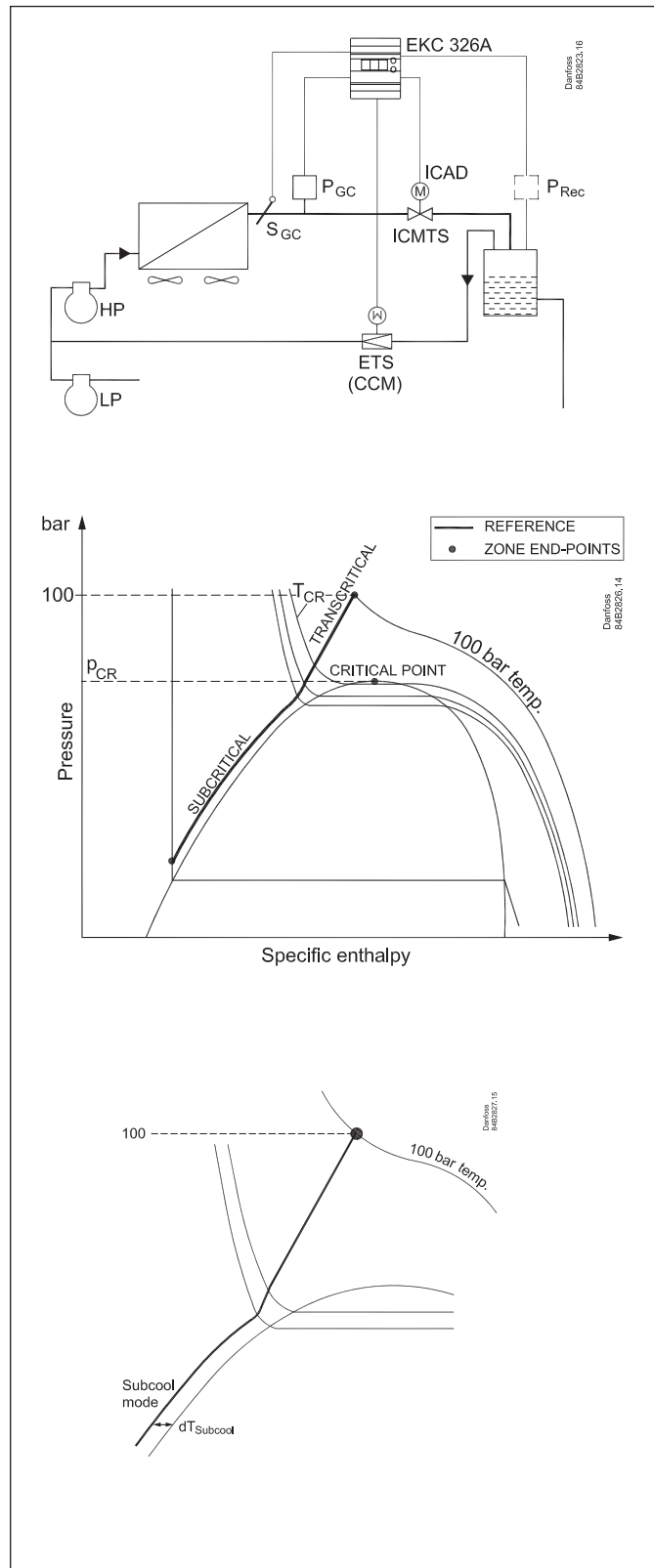

Contents

Introduction	2
Examples	4
Survey of functions.....	6
Operation	10

Menu survey.....	10
Connections.....	11
Data.....	13
Ordering.....	13
Appendix.....	14

Receiver control

The receiver pressure can be controlled so that it is kept at a set reference pressure. This control requires the installation of an ETS valve a (CCM valve) and a pressure transmitter. If only monitoring and not control is required, the valve should not be installed. Install the pressure transmitter only.

Ensuring that the receiver pressure is not too low

A limit value can be set, and if the pressure falls below this value, the ICMTS valve will be opened. The valve will then open gradually through the associated P band. Open to the value "n32" (Vhp OD Max).

Protecting against high receiver pressure

A limit value can be set, and if the pressure rises beyond this value, the ICMTS valve will be closed. The valve will then close gradually through the associated P band.

Extra refrigeration capacity ("extra compressor")

This function improves the system's refrigeration capacity by increasing the reference pressure in the gas cooler with a offset value.

It is activated via a switch function.

Heat recovery or heat pump

This function will increase the gas pressure to a set value. This value will be equivalent to a specific temperature.

The value can either be fixed or can vary in accordance with an input signal of 0-10 V as follows:

A signal of 1.5 V or above can activate the function and increase the reference to Pgc HR Min.

If a variable reference is required, then a signal between 2-10 V can be connected. The signal will increase the reference further. This function works both in subcritical and transcritical ranges.

Output signal

The controller has a voltage output on 0-10 V. The signal is used to control the ICMTS valve via the ICAD actuator.

Valves opening degree

The opening degree of both ICMTS and ETS valves (CCM valve) can be narrowed if necessary.

PC-operation

The controller can be provided with data communication so that it can be connected to other products in the range of ADAP-KOOL® refrigeration controls. In this way operation, monitoring and data collection can be performed from one PC – either on the spot or in a service company.

Temperature reading

The temperature by the gas cooler must be measured using a Pt 1000 ohm sensor type AKS 21.

The sensor must be mounted immediately next to the gas cooler outlet to produce a correct signal.

Pressure reading (bar)

The pressure by the gas cooler must be measured using a pressure transmitter type AKS 2050.

The pressure transmitter must be mounted immediately next to the gas cooler outlet to produce a correct signal.

Emergency cooling

The valve's average opening degree for the last six hours is regularly saved. This opening degree is used if there is a need for emergency cooling.

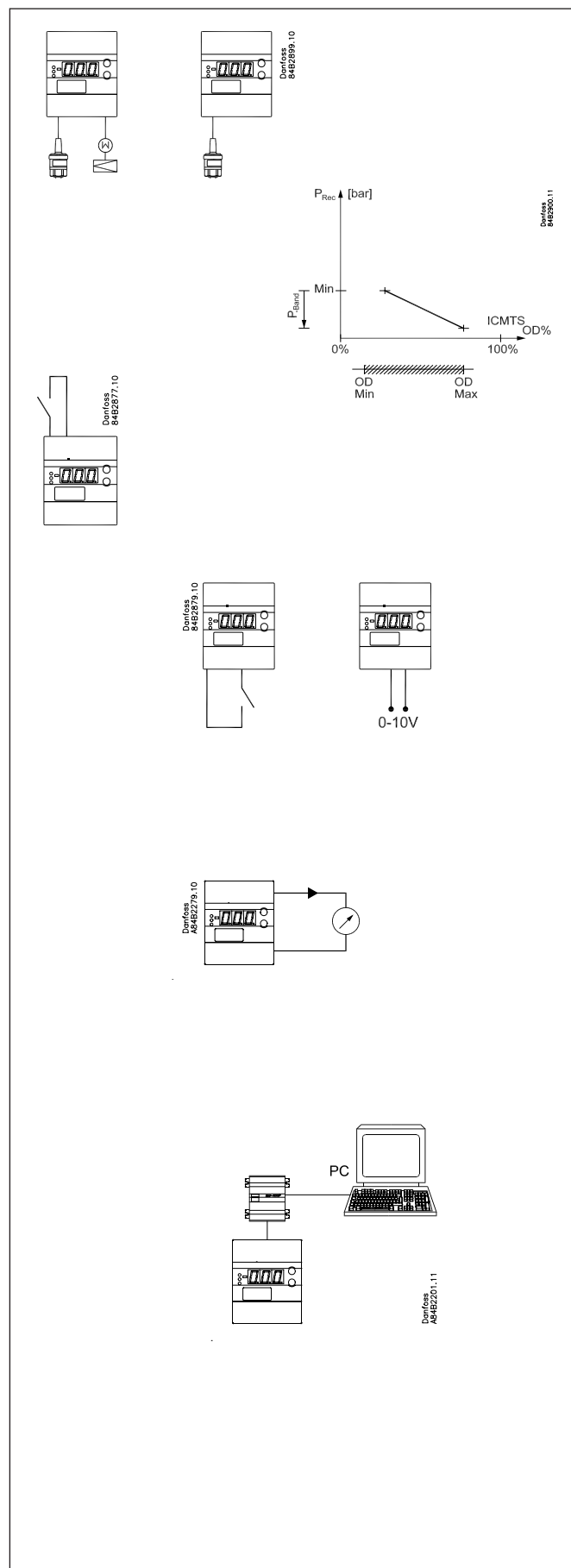

Examples

Simple heat recovery system

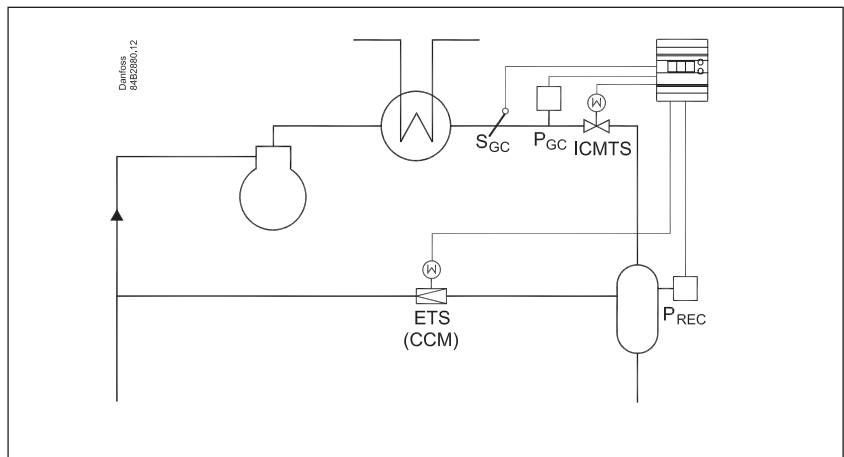

Partial heat recovery system

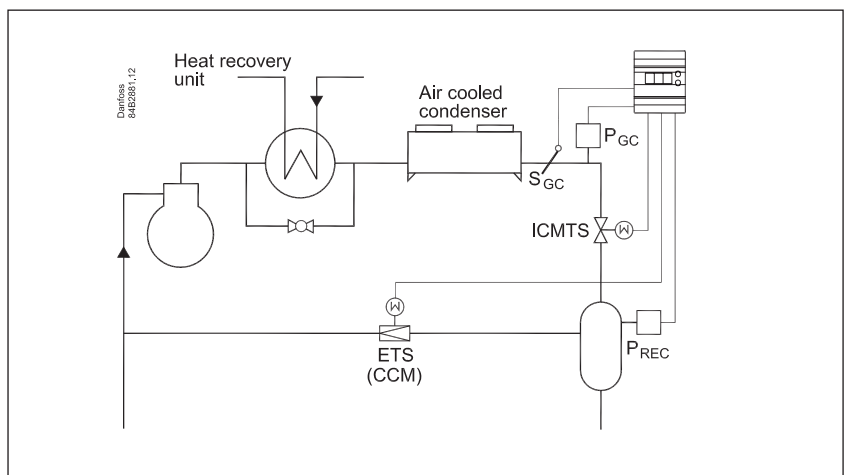

Heat recovery system (or heat pump system)

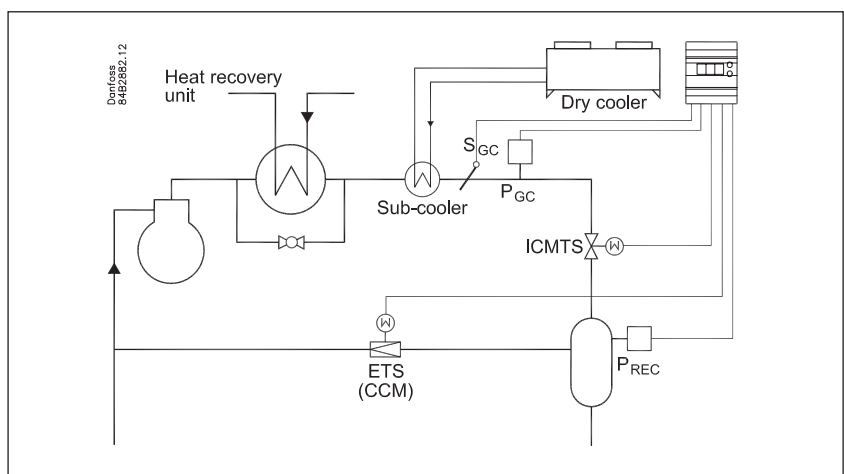

Extra refrigeration capacity ("extra compressor")

This function improves the system's refrigeration capacity by increasing the reference pressure ($P_{gc\ Ref}$) in the gas cooler. The cooling performance increases to Q_0+dQ_0 .

The function also increases the load on the compressor motor as pressure increases. Power consumption increases to Q_m+dQ_m .

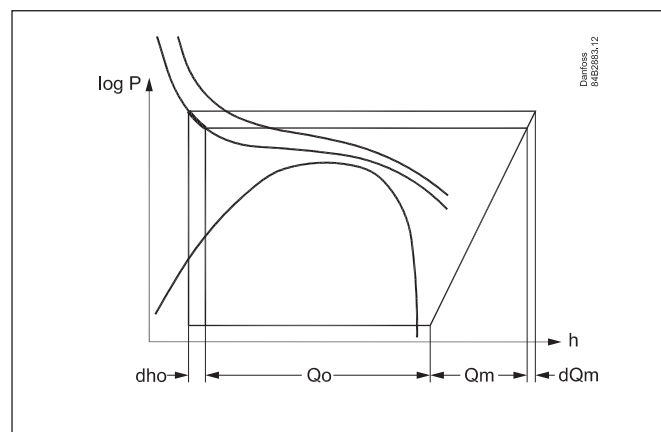

Increasing pressure reference with heat recovery

The function will increase the gas pressure reference to the $P_{gc\ HR\ Min.}$ value when it receives a signal.

The function is activated by an on/off signal at the voltage input.

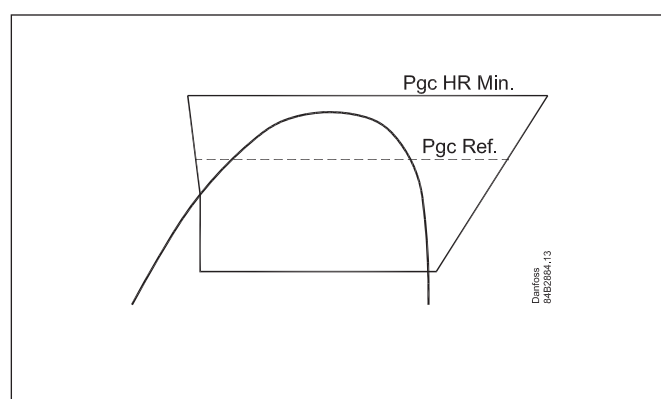

Increasing pressure reference with heat recovery, variable reference

The function will increase the gas pressure reference to the value where it receives a signal.

The function is activated by a voltage signal between 0-10 V.

- Between 0-2 V it is regulated normally
- At 2 V the reference changes to the setting "Pc HR Min"
- At 10 V the reference will increase further using the setting "Pgc HR offset"
- Between 2-10 V the reference is variable.

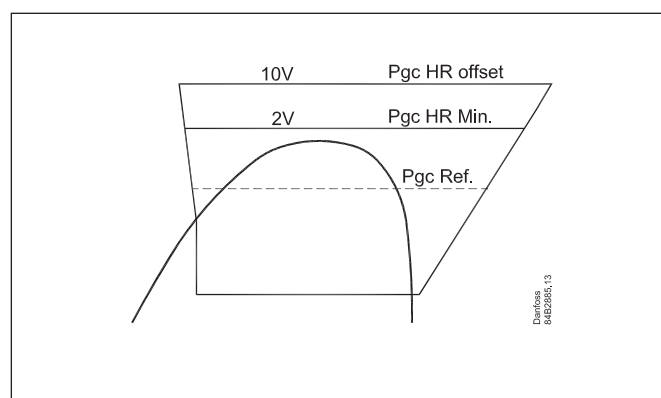

Survey of functions

Function	Parameter	Parameter by operation via data communication
Normal display		
The normal display shows the pressure in the gas cooler. The pressure is measured using Pgc. The measurement can also be seen in menu U06. The control reference can be viewed by pressing both buttons. If a pressure transmitter is mounted to display the receiver pressure, the measurement can be brought up on the display by pressing the lower button. The measurement can also be seen in menu U07.	U06 U07	Pgc bar Prec bar
Gas pressure control		Gas cooler control
Defining the reference line Set the end point for the reference line in the transcritical range. Set the desired temperature value at 100 bar.	n99	T100
The reference The reference is pre-programmed to follow the optimal COP from the pressure/enthalpy chart. See the illustration on page 2. The current reference can be read off in menu U03.	U03	Pgc Ref
Start/stop of regulation This setting can be used to start and stop regulation. Stopping regulation will always cause the valve will close at the value set in "n87" and "n93". The function in o02 requires that it has been defined.	r12	Main Switch
Max. opening degree The ICMTS-valve's opening degree can be limited here. Limitation takes place by limiting the voltage signal that is sent to the valve actuator. The setting is expressed as a % of the total opening degree. The voltage signal of 0-10 V on the output will be limited correspondingly.	n32	Vhp OD Max
Minimum opening degree The closing degree of the ICMTS valve can be limited here. Limitation takes place by increasing the lower part of the voltage signal that is sent to the valve actuator. The setting is expressed as a percentage of the total opening degree. The output voltage signal of 0-10 V will be limited correspondingly.	n87	Vhp OD Min
The gas cooler's max. pressure This is where you define the maximum pressure permitted in the gas cooler. If the pressure reaches this value, the valve is open as set in "n32 OD max".	n69	Pgc Max
P-band to force open the valve from normal regulation P-band under "n69, Pgc Max lim", where the valve is forced open so that the valve is fully open if the pressure reaches "n69, Pgc Max lim". The pressure is not critical, so opening of the valve will take place under controlled conditions.	n70	Pgc P-band
The gas cooler's min. pressure This is where you define the minimum pressure permitted in the gas cooler.	n81	Pgc Min
Subcooling is required to be regulated according to temperature Set the desired subcooling in K.	n79	dT Subcool
P: Amplification factor Kp If the Kp value is reduced the regulation becomes slower.	n04	Kp Gascool
I: Integration time Tn If the Tn value is increased the regulation becomes slower	n05	Tn Gascool
Increasing refrigeration capacity This function increases the gas pressure reference. Control moves from optimum COP control to maximum refrigeration control. (The pressure increases, temperature remains unchanged and the total heat content increases.) Set the pressure increase value. The function is activated by closing the switch function on terminals 1 and 2. (see o02)	n88	Pgc Cap Offset

<p>Minimum pressure reference during heat recovery <i>The function can only be used if heat recovery or heat pumps are also used in the system.</i> The function will increase the gas pressure to the set value when it receives a signal. The function is activated by a voltage signal at the input to terminal 20. A voltage over 1.5 V will activate the function. (Please install a support relay if there is any risk of error signals, e.g. with long wires.) If the function is only required for displacement, r68 should be set to 0. (The gas pressure can be further increased using the r68 function.)</p>	n89	Pgc HR Min
<p>Displacement of the control reference during heat recovery This function increases the reference to a value above the n89 setting, but no higher than the set value. Displacement occurs when an input voltage of above 2 V is received for terminal 20. The new reference is: Setting in n89 + displacement. The value of the displacement is determined by the voltage signal and the setting for r68. 10 V gives maximum displacement, i.e. the set value. 2 V or below will give nothing. Displacement is linear between 2 and 10 V.</p>	r68	Pgc HR offset
<p>Ramp for reference modification This can be used to set the speed at which the reference must drop again following heat recovery (number bar/min). The function is only active after heat recovery is complete.</p>	r65	Pgc Ref Ramp
Receiver control		Receiver pressure control
<p>Receiver control Whether control of the receiver pressure should take place is defined here. On: ETS (CCM) control. Alarm active Off: No ETC (CCM) control. No alarm. Pressure control is active</p>	n90	Prec. Ctrl
<p>Receiver reference The reference for receiver control is set here.</p>	n91	Prec Ref
<p>Maximum opening degree The ETS (CCM) valve's opening degree can be limited here. The setting is expressed as a percentage of the total opening degree.</p>	n92	Vgbp OD Max
<p>Minimum opening degree The closing degree of ETS (CCM) valves can be limited here. The setting is expressed as a percentage of the total opening degree.</p>	n93	Vgbp OD Min
<p>Min. pressure in the receiver The function monitors the pressure in the receiver and will start to force open the ICMTS-valve if the pressure falls below the preset value. The value must be at least 1 bar below the reference. The function is deactivated if n72 is set to 0.</p>	n71	Prec Min
<p>P-band to force open the ICMTS-valve if the receiver pressure is too low P-band under "n71, Prec Min" when the valve is forced open. If the pressure falls to n71 minus n72, the ICMTS valve will open to the value in n32, Vhp OD Max. An alarm is then transmitted. The pressure is not critical, so opening of the valve will take place under controlled conditions.</p>	n72	Prec Min Pband
<p>P: Amplification factor Kp If the Kp value is reduced the regulation becomes slower.</p>	n60	Kp Receiver
<p>I: Integration time Tn If the Tn value is increased the regulation becomes slower</p>	n61	Tn Receiver
<p>Actuator type If receiver control takes place, the type of valve should be set: 0: ETS 12½, ETS 25, CCM 10, CCM 20 1: ETS 50, CCM 30 2: ETS 100, CCM 40 3: ETS 250 4: ETS 400 5: Other type. "n37" and "n38" should also be set when the setting = 5 ("n37" and "n38" are automatically set for settings 0 to 4) 6: CCMT 2, 4, 8</p>	n03	Valve type
<p>ETS (CCM) setting Number of steps open from 0-100% Automatically set when "n03" is set to 0, 1, 2, 3, 4 or 6</p>	n37	Max. steps
<p>ETS (CCM) setting Speed of spindle travel (no. of steps per second) Automatically set when "n03" is set to 0, 1, 2, 3, 4 or 6</p>	n38	Steps / sec

Max. pressure in the receiver The function monitors the pressure in the receiver and will initiate the closing of the ICMTS valve if the pressure exceeds the preset value. The value must be at least one bar over the reference. The function is not activated when 'n59' is set to 0. (If n70 is active and attempts to open the valve, n58 will not be active.)	n58	Prec Max
P-band to force closing the ICMTS-valve if the receiver pressure is too high P-band over "n58, Prec Max" when the valve is forced closed. If the pressure becomes 'n58' plus 'n59', the ICMTS valve will be closed. The closing of the valve will take place under controlled conditions.	n59	PrecMaxPband
Miscellaneous		
Digital input signal - DI (terminal 1 and 2) The controller has a digital input which can be used for one of the following functions: 0: The input is not used 1: External main switch (se also r12) 2: Increasing the pressure in the gas cooler (additional cooling capacity). (closed DI = additional capacity)	o02	DI Config
Address If the controller is built into a network with data communication, it must have an address, and the master gateway (system unit) of the data communication must then know this address. These settings can only be made when a data communication module has been mounted in the controller and the installation of the data communication cable has been completed. This installation is mentioned in a separate document "RC8AC"		Following installation of a data communication module, the controller can be operated on a par with the other controllers in ADAP-KOOL® refrigeration controls.
The address is set between 0 and 119 (999)	o03	-
The address is sent to the gateway when the menu is set in pos. ON (The setting will automatically change back to Off after a few seconds.)	o04	-
Frequency Set the net frequency.	o12	50 / 60 Hz (50=0, 60=1)
Pressure transmitter definition for Pgc. Pressure transmitter lower limit	o20	MinTransPgc
Pressure transmitter definition for Pgc. Pressure transmitter upper limit	o21	MaxTransPgc
Pressure transmitter definition for Prec. Pressure transmitter lower limit	o47	MinTransPrec
Pressure transmitter definition for Prec. Pressure transmitter upper limit	o48	MaxTransPrec
Alarm settings		Alarm settings
Pgc Min alarm limit An alarm is issued if the value is exceeded	A65	PgcMin ALLim
Permitted variation in relation to Pgc reference An alarm is issued if the Pgc pressure falls below or exceeds the permitted variation, but only once the delay time has expired. This is an 'A94 PgcRef alarm'.	A66	PgcAl Limit
Permitted variation in relation to the Prec reference An alarm is issued if Prec pressure exceeds or falls below the permitted variation, but only once the delay time has expired. This is an 'A95 PrecRef alarm'.	A67	PrecAl Limit
Delay time for 'A94 PgcRef alarm'	A68	PgcAlDelay
Delay time for 'A95 PrecRef alarm'	A69	PrecAlDelay
Service		
A number of controller values can be printed for use in a service situation		
Read input voltage at Ai-input	u07	AI Volt
Read status of input DI (start/stop input)	u10	DI
Opening degree for ETS (CCM) valve	u24	Vgbp OD %
Calculated reference for regulation (desired pressure in the gas cooler)	U03	Pgc Ref
The output signal to the high pressure valve ICMTS converted into opening degree	U04	Vhp OD %
The temperature in the gas cooler. Measured using temperature sensor Sgc.	U05	Sgc temp.
The pressure in the gas cooler. Measured using pressure transmitter Pgc.	U06	Pgc bar
The pressure in the receiver. Measured using pressure transmitter Prec, but only if it is mounted.	U07	Prec bar

Operating status	
The controller's operating status can be called forth by a brief (1s) activation of the upper button. If a status code exists it will be shown. (Status codes have lower priority than alarm codes. This means that status codes cannot be seen if there is an active alarm code. The individual status codes have the following meanings:	EKC State (0 = regulation)
S10 (off): Regulation stopped by the internal start/ stop.	10
S20: Emergency cooling is activated because of defect sensor	20
S42: Heat recovery or heat pump control is active	42
S43: Higher capacity through displacement of the pressure reference	43
Alarms	
E1: Fault in controller	Controller fault
E15: Cut-out Sgc sensor	Sgc o.c.
E16: Short circuited Sgc sensor	Sgc S.C.
E20: Fault on the signal from Pgc	Sgc input err
E39: Fault on the signal from Prec	Prec input err
A43: Step motor error. Output or phase	Step motor err
A45: Regulation stopped. Main switch r12 = off	Standby mode
A82: The Pgc gas pressure measured is higher than the maximum limit for n69	PgcMax alarm
A83: The Pgc gas pressure measured is lower than the minimum limit for A65	PgcMin alarm
A84: The receiver pressure measured is lower than "n71" minus "n72"	PrecMin alarm
A94: Pgc gas pressure measured is outside the permitted reference	PgcRef alarm
A95: Prec receiver pressure measured outside the permitted reference	PrecRef alarm

Operation

Display

The values will be shown with three digits.
Temperature are to be shown in °C and pressure in bar.

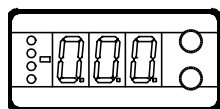

Light-emitting diodes (LED) on front panel

The four LED's will flash, if there is an error in the regulation.
In this situation you can upload the error code on the display and cancel the alarm by giving the uppermost button a brief push.

The controller can give the following messages:		
E1	Error message	Fault in controller
E15		Cut-out Sgc sensor
E16		Short circuited Sgc sensor
E20		Fault on the signal from Pgc
E39		Fault on the signal from Prec
A43	Alarm message	Step motor error. Output or phase
A45		Regulation stopped. Main switch r12 = off
A82		The Pgc gas pressure measured is higher than the maximum limit for n69
A83		The Pgc gas pressure measured is lower than Pgc min (A65)
A84		The receiver pressure measured is lower than "n71" minus "n72"
A94		Pgc alarm limit "A66" is exceeded
A95		Prec alarm limit "A67" is exceeded

The buttons

When you want to change a setting, the two buttons will give you a higher or lower value depending on the button you are pushing. But before you change the value, you must have access to the menu. You obtain this by pushing the upper button for a couple of seconds - you will then enter the column with parameter codes. Find the parameter code you want to change and push the two buttons simultaneously. When you have changed the value, save the new value by once more pushing the two buttons simultaneously.

- Gives access to the menu (or cutout an alarm)
- Gives access to changes
- Saves a change

Examples of operations

Set a menus

1. Push the upper button until a parameter is shown
2. Push one of the buttons and find the parameter you want to change
3. Push both buttons simultaneously until the parameter value is shown
4. Push one of the buttons and select the new value
5. Push both buttons again to conclude the setting

Menu survey

SW =2.0x

Function	Parameter	Min.	Max.	Factory setting
Normal display				
Shows the current pressure after the gas cooler Pushing both buttons briefly will display the reference Pushing the bottom button briefly will display Prec.	-		bar	
Start / stop				
Start / stop of regulation	r12	OFF (0)	On (1)	On (1)
Ramp for reference after heat recovery	r65	0.1	20	1
Displacement of the Pgc minimum reference (n89) during heat recovery. (Displacement value at 10 V)	r68	0 bar	100 bar	0
Alarm Settings				
Alarm limit for Pgc Min.	A65	0 bar	200 bar	40
Permitted Pgc reference variation 0 = no alarm function (recommended)	A66	0 bar	50 bar	0
Permitted Prec reference variation 0 = no alarm function (recommended)	A67	0 bar	50 bar	0
Delay time for 'A94' Pgc reference alarm	A68	5 min.	360 min	15
Delay time for 'A95' Prec reference alarm	A69	5 min.	360 min	15
Regulating parameters				
Actuator type for receiver control 0=ETS12,5/25 / CCM10/20, 1=ETS50 / CCM30, 2=ETS100 / CCM40, 3=ETS250, 4=ETS400, 5=User defined (set: n37 and n38) 6=CCMT2/4/8	n03	0	6	0
P: Amplification factor Kp	n04	0.5	20	2.0
I: Integration time Tn	n05	10 s	600 s	75
Max. opening degree. of the valve	n32	0	100	100
Number of steps from 0-100% opening degree (x10) **	n37	0	500	262
Number of steps per second	n38	0	300	250
Max. permitted receiver pressure, Prec	n58	10 bar	200 bar	60
P-belt beyond PrecMax for valve to close	n59	0 bar	60 bar	0
P: Amplification factor Kp for receiver	n60	0.5	20	5
I: Integration time Tn for receiver	n61	10	600	75
The gas cooler's max. pressure This is where you set the maximum pressure permitted in the gas cooler. If the pressure reaches this value, the valve is fully open.	n69	7	200	90
P-band under n69, so the valve is fully open if the pressure is n69.	n70	0	60	5
Min. pressure in the receiver This function is only used if the pressure transmitter Prec is mounted.	n71	7	60	30
P-band to force open the valve if the receiver pressure is too low	n72	0	60	3
Subcooling is required to be regulated according to temperature Set the desired subcooling in K.	n79	1 K	30 K	1
The gas cooler's min. pressure	n81	7	200 bar	45
Min. permissible opening degree for ICMTS	n87	0	100%	0
Extra capacity when the contact is closed. (The Pgc reference is increased with this value)	n88	0 bar	200 bar	0
Minimum permitted Pgc reference during heat recovery (AI > 2 V). The value can be increased further using the r68 function.	n89	7 bar	200 bar	7
Do you require receiver pressure control: Off=no, On=yes	n90	Off	On	On
Prec. reference for receiver pressure control	n91	7 bar	200 bar	35
Receiver pressure control. Maximum opening degree for ETS	n92	0%	100%	100
Receiver pressure control. Smallest opening degree for ETS	n93	0%	100%	0
Define the reference curve point at 100 bar.	n99	35°C	55°C	39

***) The display on the controller can show 3 digits only, but the setting value has 4 digits. Only the 3 most important will be shown. It means fx. 250 will give a setting of 2500.

Miscellaneous				
Digital input signal - DI 0: The input is not used 1: External main switch 2: additional cooling capacity	o02	0	2	0
Controller's address	o03*	0	240	-
ON/OFF switch (service-pin message)	o04*	-	-	-
Set supply voltage frequency	o12	50Hz (0)	60 Hz (1)	0
Pressure transmitter range Pgc - min.	o20	-1 bar	5 bar	-1
Pressure transmitter range Pgc - max.	o21	6 bar	199 bar	159
Pressure transmitter range Prec - min.	o47	-1 bar	5 bar	-1
Pressure transmitter range Prec - max.	o48	6 bar	199 bar	59

*) This setting will only be possible if a data communication module has been installed in the controller.

Service			
Signal on AI the input	u07		V
Read status of input DI	u10		on/off
Read ETS/CCM valves opening degree	u24		%
Calculated reference for regulation (desired pressure in the gas cooler)	U03		bar
The output signal to the ICMTS valve converted into opening degree	U04		%
The temperature in the gas cooler. Measured using temperature sensor Sgc.	U05		°C
The pressure in the gas cooler. Measured using pressure transmitter Pgc.	U06		bar
The pressure in the receiver. Measured using pressure transmitter Prec, but only if it is mounted.	U07		bar

Factory setting

If you need to return to the factory-set values, it can be done in this way:

- Cut out the supply voltage to the controller
- Keep both buttons depressed at the same time as you reconnect the supply voltage

Connections

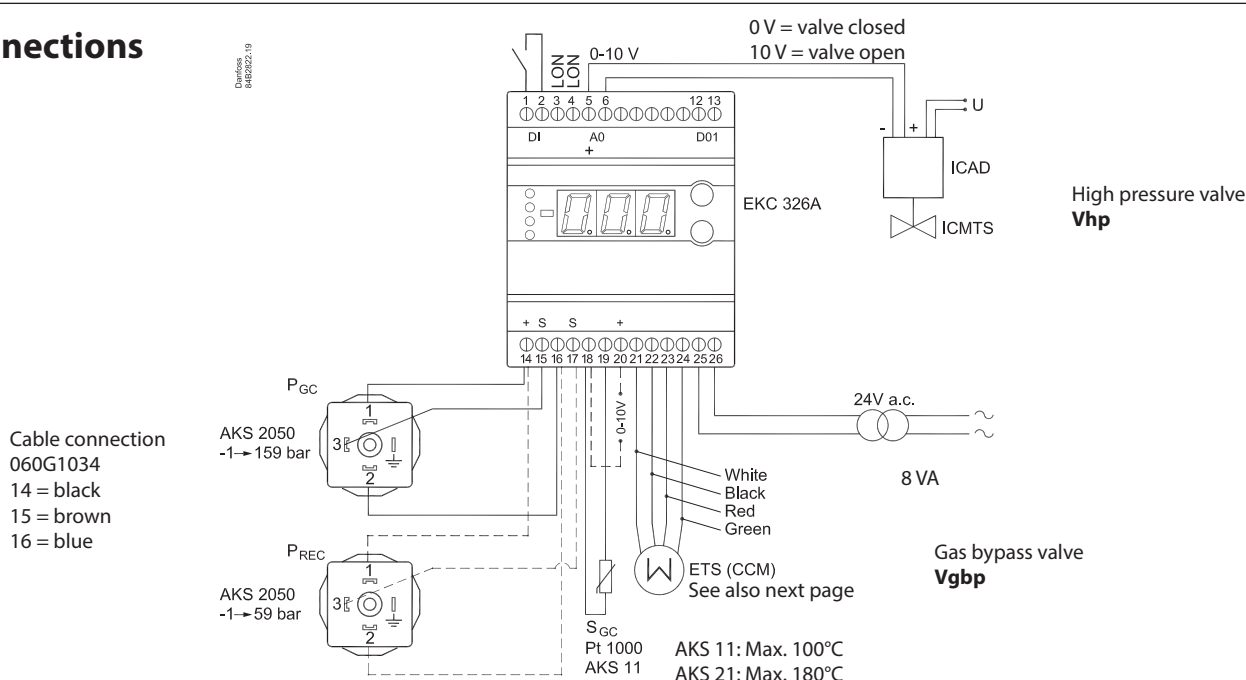

Necessary connections

Terminals:

- 25-26 Supply voltage 24 V a.c.
- 18-19 Pt 1000 sensor at gas cooler outlet (S_{gc})
- 14,15,16 Pressure transmitter AKS 2050, -1 to 159 bar
To register the correct pressure it must be mounted as close as possible to the gas cooler.
- 5-6 Voltage output to control the ICMTS valve.

Important
PGC and Sgc must be mounted near the gas cooler outlet to produce a correct signal.

Application dependent connections

Terminals:

- 1-2 DI-input to either:
External main switch (see o02 and r12)
OR
Contact function for increasing capacity (optimised COP operation stopped). (see o02)
Open connection = optimised COP operation
Closed connection = extra capacity.
- 12-13 Alarm relay
There is connection between 12 and 13 in alarm situations
- 14,16,17 Optional. A pressure transmitter can be connected so that the pressure in the receiver can be monitored. The pressure transmitter must be an AKS 2050, -1 to 59 bar.
- 21-24 If receiver pressure is to be controlled, a CCM or ETS valve should be connected.
- 18-20 Heat recovery. A voltage signal between 2 and 10 V will increase the gas pressure reference.
- 3-4 Data communication
Mount only, if a data communication module has been mounted.
It is **important** that the installation of the data communication cable be done correctly. Cf. separate literature No. RC8AC...

ETS (CCM) connection

If the distance between EKC 326A and the ETS (CCM/CCMT) valve exceeds 5 m a filter must be mounted to obtain the correct valve function. The filter must be placed close to EKC 326A.

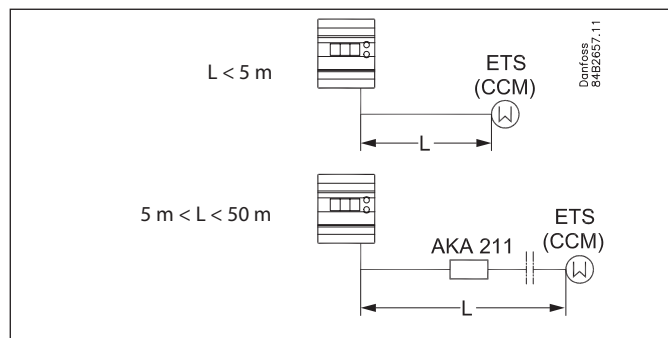

Connection

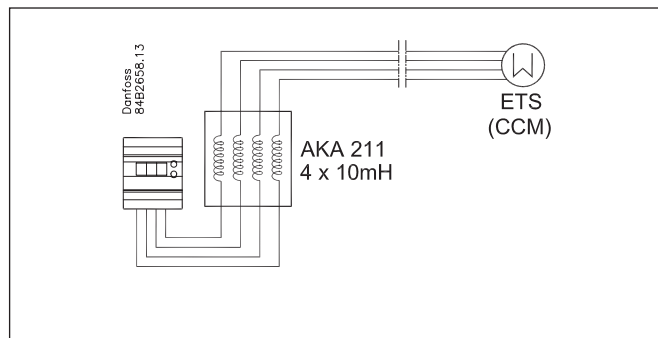

Dimensions

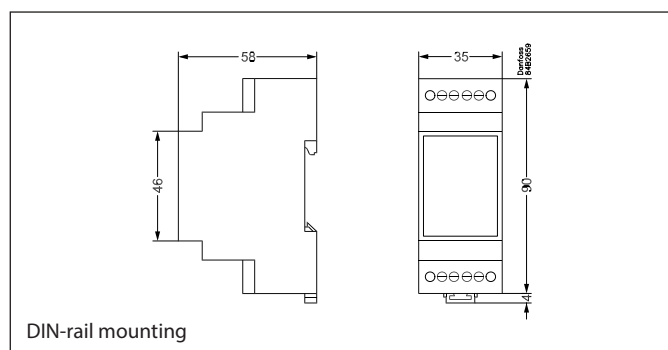

Ordering

Type	Description	Ordering
AKA 211	Filter 4 x 10 mH	084B2238

Data

Supply voltage	24 V a.c. +/-15% 50/60 Hz (the supply voltage is galvanically separated from the input and output signals)	
Power consumption	Controller	8 VA
Input signal	Pressure transmitter	Ratiometric, AKS 2050
	Pressure transmitter	Ratiometric, AKS 2050
	Digital input from external contact function	
	Voltage signal	0-10 V Ri = 100 k ohm Signal range = 2-10 V
	Sensor input	1 pcs. Pt 1000 ohm
Alarm relay	1 pcs. SPST	250 V a.c. AC-1: 4 A (ohmic) AC-15: 3 A (inductive)
Actuator	ICAD mounted on ICMTS	Voltage signal 0-10 mA
	ETS / CCM or CCMT 2-8	Step motor I-max. = 100 mA
Data communication	Possible to connect a data communication module type EKA 174	
Environments	-10 to +55°C, during operations	
	-40 to +70°C, during transport	
	20 - 80% Rh, not condensed	
	No shock influence / vibrations	
Enclosure	IP 20	
Weight	300 g	
Mounting	DIN rail	
Display	LED, 3 digits	
Terminals	max. 2.5 mm ² multicore	
Approvals	EMC acc. EN 61000-6-3 and EN 61000-4-(2-6, 8, 11) LVD acc. EN 60730-1 and EN 60730-2-9	

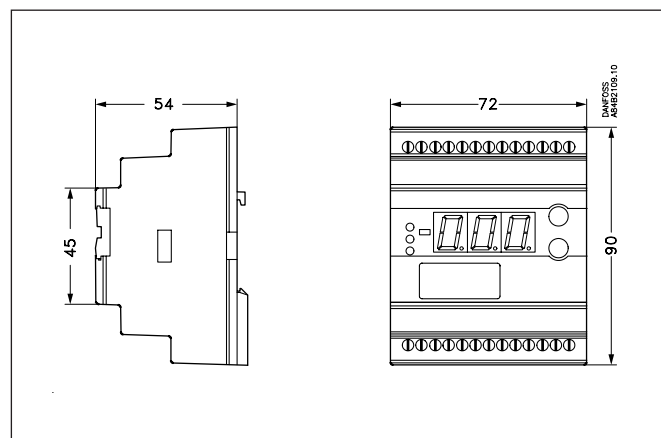

Ordering

Type	Function	Code no.
EKC 326A	Gas pressure controller	084B7252
EKA 174	Data communication module (accessories), (Lon-RS 485 module) with galvanic separation	084B7124

Temperature sensor Pt 1000 ohm: Kindly refer to catalogue RK0YG
 Pressure transmitter type AKS 2050 Kindly refer to tech.broch RD5GJ

Appendix

Guideline for setting automatic safety control

The following ratio between pressure and temperature can be used to set the automatic safety control.

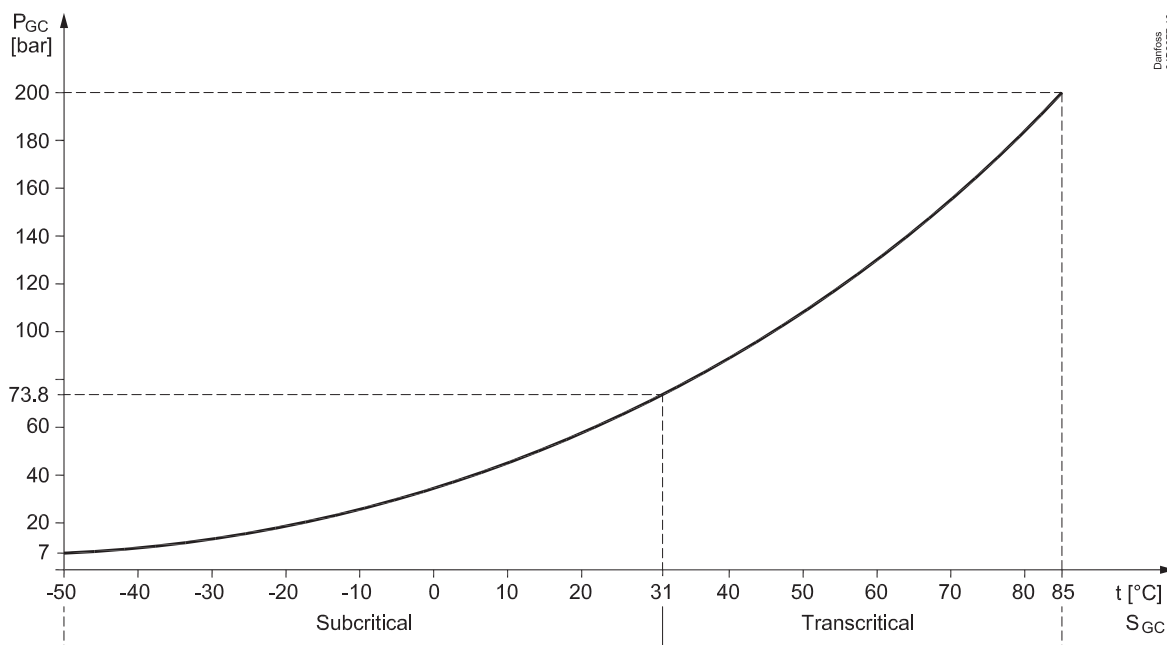

Safety functions

There are two safety functions for the receiver. They are only available for gas-cooled regulation. A P-belt must be installed to be able to regulate the function, but both are standard set to zero, which makes the function inactive.

Receiver pressure's max. limit

Set a max. receiver pressure. If the controller register receiver pressure beyond the set value, the ICMTS valve will be closed. The opening degree will be linear through the p-band so that the ICMTS valve will be closed by pressing 'set max. receiver pressure' plus 'set-p-band'.

If the valve's opening degree is set to a limited value and cannot be fully closed, the set opening degree value will be at the pressure 'set max. receiver pressure' plus 'set p-band'.

As such, gas can still be sent through the valve.

Receiver pressure's min. limit:

A minimum receiver pressure limit can be set. If the controller register receiver pressure below the set value, the ICMTS valve will be opened. The opening degree will be linear through the p-band, and the maximum permitted opening degree of the ICMTS will be present by pressing 'set min. receiver pressure' minus 'set-p-band'. If the setting of the valve's opening degree is limited and it cannot be fully opened, the set opening degree value will be at the pressure 'set min. receiver pressure' minus 'set p-band'.

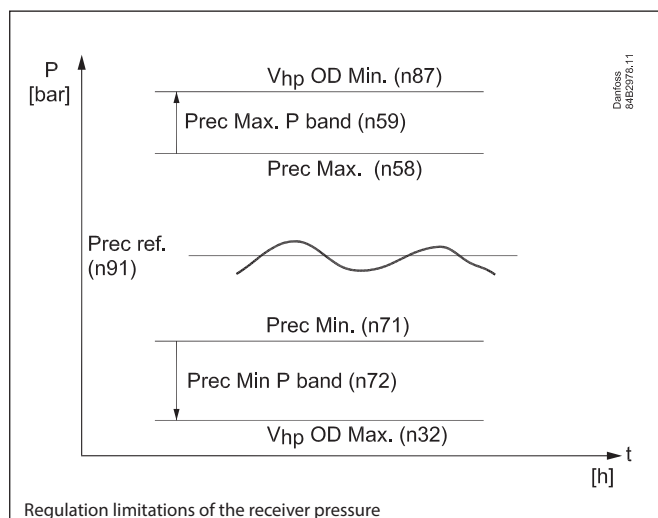

Note

The PI regulation of the receiver pressure must have space to regulate without restrictions.

This means that there should be sufficient space for the PI regulation to move around the reference, i.e. at least 2-3 bars – both over and below the reference.

The value is very dependent on the tuning of the PI regulation and the system dynamics.

An example may be a 40-bar plant in which the receiver's reference pressure is set to 35 bars. Here the system can interfere with normal regulation because the high pressure limit is very stringent.

Functions for regulation reference

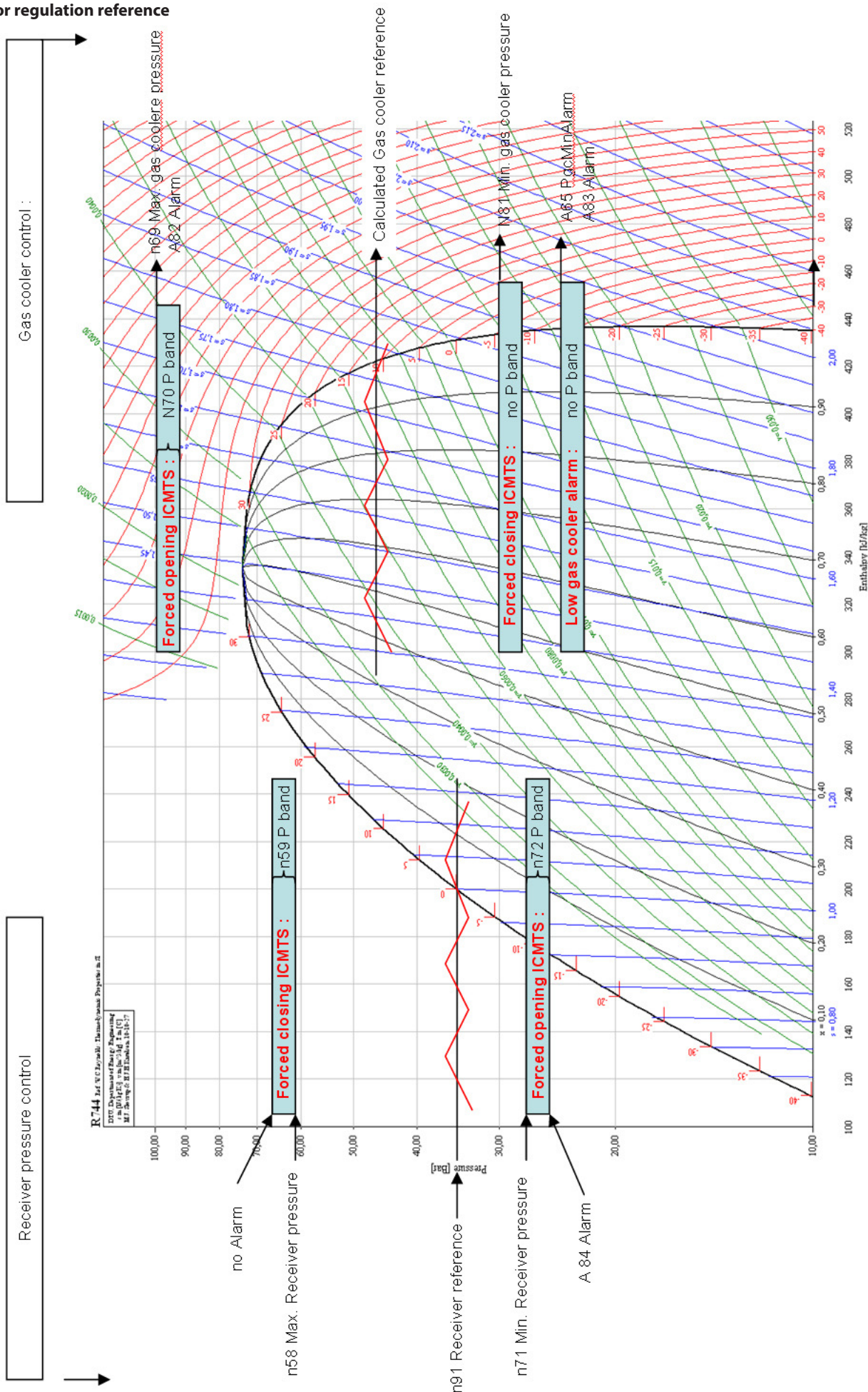

Valve function in alarm situations

Error	Alarm message	ICMTS action (Vhp)	ETS action (Vgbbp)
EKC supply interrupted	none	EKC AO remains 0 V – ICMT closes if ICMTS has battery back-up	No change in opening degree
EKC Standby – Main Switch OFF	A45 – Standby mode	ICMTS closes	ETS closes to 'Vgbbp OD Min' setting
Sgc interrupted	E15 – Sgc o.c.	ICMTS regulates with “Emergency cooling”	No change – ETS control attempts to maintain Prec
Sgc short circuited	E16 – Sgc s.c.	ICMTS regulates with “Emergency cooling”	No change – ETS control attempts to maintain Prec
Pgc transmitter error	E20 – Pgc input err	ICMTS regulates with “Emergency cooling”	No change – ETS control attempts to maintain Prec
Prec transmitter error	E39 – Prec input err	No change – ICMTS control continues	ETS regulates with “Emergency cooling”
StepMotor error	A43 – Step motor err	No change – ICMTS control continues	ETS closes to 'Vgbbp OD Min' setting
Pgc Max limit exceeded	A82 – PgcMax alarm	No change – ICMTS control attempts to lower Pgc	No change – ETS control attempts to maintain Prec
Pgc Min limit exceeded	A83 – PgcMin alarm	No change – ICMTS control attempts to raise Pgc	No change – ETS control attempts to maintain Prec
Prec Min limit exceeded	A84 – PrecMin alarm	No change – ICMTS control attempts to maintain Pgc	No change – ETS control attempts to raise Prec
PgcRef Alarm	A94 – PgcRef alarm	No change – ICMTS control attempts to maintain Pgc	No change – ETS control attempts to raise Prec
PrecRef Alarm	A95 – PrecRef alarm	No change – ICMTS control attempts to maintain Pgc	No Change – ETS control attempts to raise Prec
EKC HW error	E1 – Controller fault	No change – ICMTS control continues	No change – ETS control continues

“Emergency cooling”

The valve's average opening degree for the last six hours is regularly saved. This opening degree is used if there is a need for emergency cooling.

List of literature

- Instructions RI8NG (extract from this manual).
Here you can see how controllers are mounted and programmed.
- Installation guide for extended operation RC8AC
Here you can see how a data communication connection to ADAP-KOOL® Refrigeration control systems can be established.

Installation considerations

Accidental damage, poor installation, or site conditions, can give rise to malfunctions of the control system, and ultimately lead to a plant breakdown. Every possible safeguard is incorporated into our products to prevent this. However, a wrong installation, for example, could still present problems. Electronic controls are no substitute for normal, good engineering practice. Danfoss will not be responsible for any goods, or plant components, damaged as a result of the above defects. It is the installer's responsibility to check the installation thoroughly, and to fit the necessary safety devices.