

ENGINEERING
TOMORROW

Danfoss

Installation Instruction

Cable to cable Splice

Heat shrink technology connection system

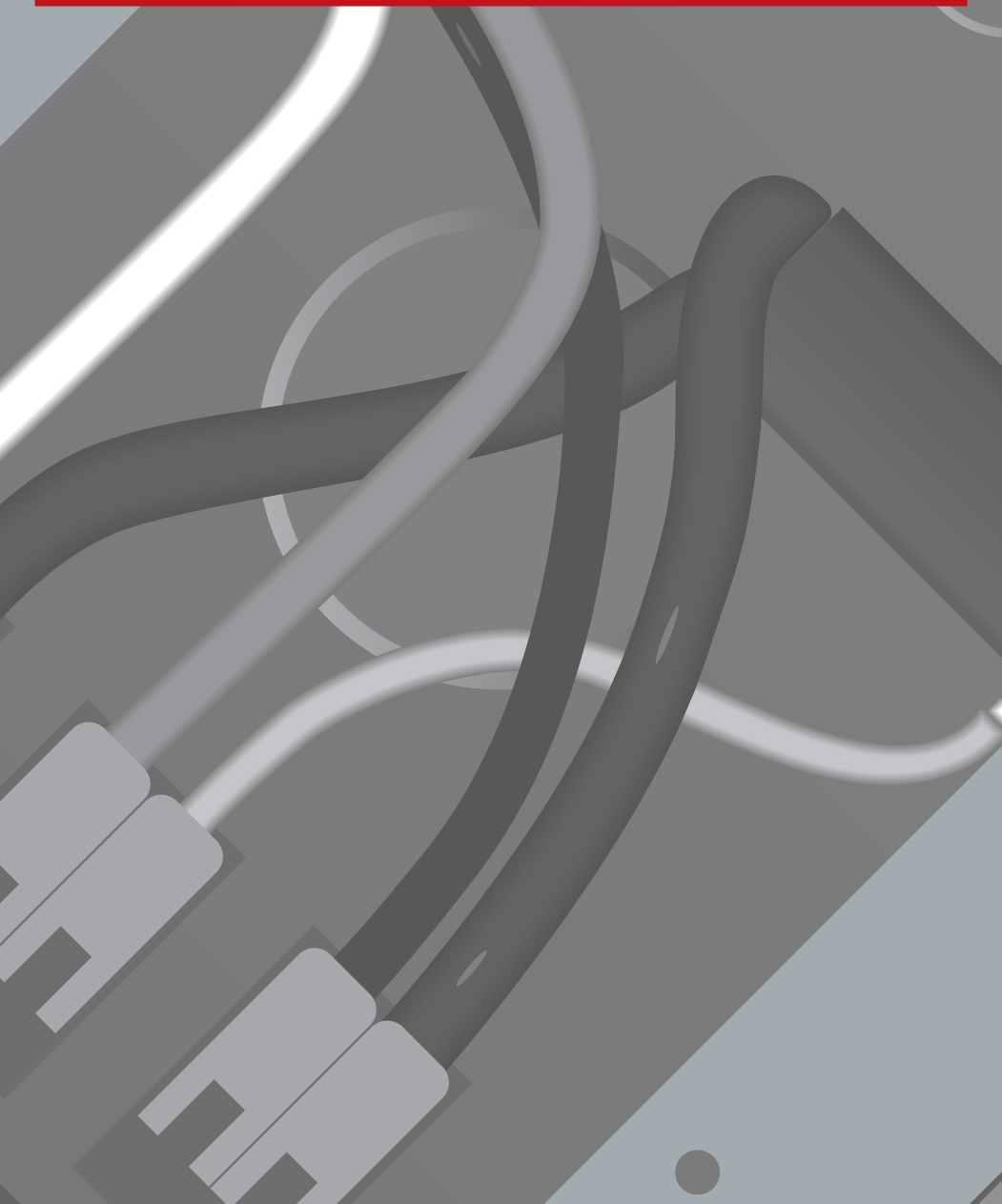

Table of contents

1	Overview	2
2	Certifications / Approvals.	3
3	Technical data	3
4	Safety	4
5	Kit contents	5
6	Installation	6
	Required tools / equipment	6
	Cautions and warnings	6
	Preparation of trace heaters	7
	Trace heater to trace heater connection	11
7	Troubleshooting	11
	Cold lead cable to trace heater connection	17
	Installation of the end seal	22
8	Troubleshooting	25
9	Safety	26
10	Sécurité et avertissements	27

1 Overview

This manual introduces the installation and operation of Danfoss heat shrink splice technology. The connection is established using splice lugs and sealed with heat shrink tubes. Catalog No.: 088L0006.

The trace heating system uses a self-regulating trace heater. It features a temperature-dependent resistive heating element that regulates and limits the heat according to the ambient temperature. If the ambient temperature rises, the power output of the trace heater is reduced. This self-regulating property prevents overheating which would cause damage to the trace heater. Even crossing or overlapping with other trace heaters (or other portions of the same trace heater) are possible.

The heating system is set up as a fixed equipment heating system for pipes in ordinary areas. Thanks to the parallel design the trace heater can be cut and installed to any required length (mind the maximum heating circuit length according to system's design guide).

It is suitable for the following self-regulating trace heaters:

- Danfoss PX Pipe Trace Heating System
- Danfoss RX-C Roof and Gutter De-Icing System

The following terms describe the parts of the trace heater within these instructions:

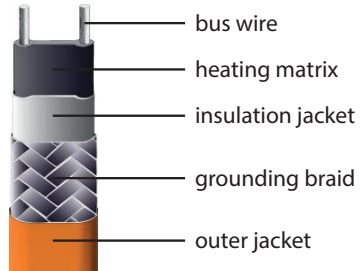

2 Certifications / Approvals



Heat shrink technology connection system for Danfoss PX/RX trace heaters.

3 Technical data

Ambient temperature range	-67 to +185 °F / -55 to +85° C
Operation temperature range	-67 to +185 °F / -55 to +85° C
Min. installation temperature	-4 °F / -20 °C
Max. circuit load	24 A
Ingress protection	NEMA Type 4X
Protection classification	N/A - for use in ordinary locations only!

4 Safety

Safety

For safe installation and operation of the cold applied connection system the technical requirements and instructions given in this manual must be followed.

WARNING

Risk of fire or electrical shock. Follow these guidelines to avoid personal injury or material damage.

- All electrical systems and installations must comply with Danfoss requirements and be installed in accordance with the relevant electrical codes and any other applicable national and local codes.
- The US and Canadian electrical codes require ground fault protection to be provided for all trace heating circuits.
- Install the connection system and trace heaters carefully.
- Use the trace heater and connection system in accordance with the intended purpose and strictly comply with the operational data specified in section Technical Data.
- The bending radius of the trace heater must be at least 1" (25 mm). Do not bend on the narrow axis.
- Any defective component of the kit must be replaced before installation.
- To avoid short circuits, do not connect the trace heater bus wires together.
- Keep all components and the trace heaters dry before and during installation.
- Beware of hot surfaces when using the heat gun.
- Keep these instructions for future reference. If applicable, leave them with the end user.
- De-energize before installation or servicing.
- Use only original accessories.

NOTICE

The following instructions are provided in English only. Refer to www.danfoss.com for the French version.

Sécurité

Afin de garantir la sécurité lors de l'installation et de l'utilisation du système de connexion à liaison froide, il est impératif de respecter les exigences ainsi que les consignes techniques mentionnées dans le présent manuel.

AVERTISSEMENT

Risque d'incendie ou d'électrocution. Suivez ces consignes pour éviter toute blessure ou dommage matériel.











- Tous les systèmes et installations électriques doivent satisfaire aux exigences imposées par la société Danfoss et doivent être installés conformément aux normes électriques en vigueur ainsi qu'aux autres prescriptions nationales et locales applicables.
- Les normes électriques américaines et canadiennes imposent une protection contre les défauts à la terre pour tous les circuits de traçage électrique.
- Notez que le guide de conception fourni avec chaque câble chauffant contient des informations importantes additionnelles qu'il convient de respecter en plus du présent manuel.
- La pose du système de connexion et des câbles chauffants doit être réalisée avec le plus grand soin.
- Utilisez le câble chauffant et le système de connexion adaptés à l'usage prévu et répondant aux caractéristiques de fonctionnement spécifiées à la section Caractéristiques techniques.
- Le rayon de courbure du câble chauffant ne doit pas être inférieur à 1" (25 mm). Ne pas courber le câble chauffant sur la tranche.
- Tout élément défectueux dans le kit doit être remplacé avant l'installation.
- Pour éviter un court-circuit, ne jamais raccorder ensemble les deux conducteurs du câble chauffant.
- Conservez tous les éléments et les câbles chauffants au sec avant et pendant l'installation.
- Soyez prudent lors de l'utilisation du pistolet à air chaud, certaines surfaces peuvent devenir brûlantes.
- Conservez ces instructions pour un usage ultérieur. Le cas échéant, remettez-les à l'utilisateur final.
- Mettre hors tension avant toute installation ou opération de maintenance.
- Utilisez exclusivement des pièces et accessoires d'origine.

AVIS

Les instructions qui suivent sont fournies en anglais uniquement. Veuillez vous référer au site www.danfoss.com pour la version française.

5 Kit contents

The following table lists the kit contents for the Danfoss heat shrink technology connection system:

 <p data-bbox="77 898 352 975">Heat shrink technology connection system for Danfoss PX / RX trace heaters</p>	No.	Component	Qty.	Designation	Dimensions
	1		3 x	Bus wire splice lug with heat shrink tube	-
	2		4 x	Ferrule	-
	3		4 x	Heat shrink tube for bus wires	Length: 1 3/8" / 35 mm Diameter: 3/16" / 4,8 mm
	4		2 x	Outer heat shrink tube for bus wires	Length: 3/4" / 19 mm Diameter: 3/8" / 9,5 mm
	5		1 x	Connection covering heat shrink tube	Length: 4 1/2" / 115 mm Diameter: 1/2" / 12 mm
	6		1 x	Final covering heat shrink tube	Length: 7" / 175 mm Diameter: 3/4" / 19 mm
	7		1 x	Outer protection heat shrink tube	Length: 8" / 200 mm Diameter: 3/4" / 19 mm
	8		1 x	Heat shrink tube for end-termination	Length: 3/4" / 19 mm Diameter: 1/2" / 12 mm
	9		1 x	Outer heat shrink tube for end-termination	Length: 3 1/8" / 80 mm Diameter: 3/4" / 19 mm
10		2 x	Protection heat shrink tube for end-termination	Length: 2 3/8" / 60 mm Diameter: 3/4" / 19 mm	

6 Installation

Required tools / equipment

1

The following tools and equipment are required for installation of the connection system:

- Wire cutters
- Flat screwdriver
- Crimping pliers 97 52 37 KNIPEX or equivalent
- Square-crimp crimping pliers
- Tape measure
- Utility knife
- Needle-nose pliers (2x)
- Heat gun



Cautions and warnings

2

⚠ WARNING:

Risk of fire or electrical shock. De-energize all power circuits before installation or servicing. Always use ground fault equipment protection with the heat tracing system.

- Double-check that all power circuits are de-energized before you begin your work.
- Make sure that you do not exceed the maximum heating circuit length for the trace heater type you use. Refer to the design guide of the heating system.



Preparation of trace heaters

⚠ WARNING:

Risk of short cuts and/or material damage. Keep the trace heater ends dry before and during installation. Observe the design guide of the trace heating system.

Unroll the required trace heater in a straight line and cut to the correct length. Cut off the trace heater ensuring a straight cut. **3**

Do not bend or pinch the trace heater, or pull it over sharp edges.

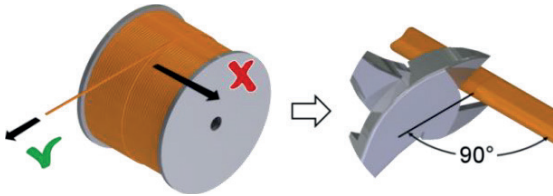

Remove 2 3/8" (60 mm) of the outer jacket on the end of the trace heater. **4**

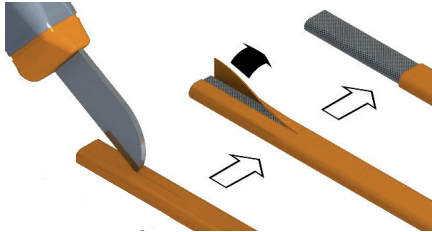

Carefully separate the strands of the grounding braid of the insulation jacket. **5**

Twist the grounding braid in order to form a pigtail.

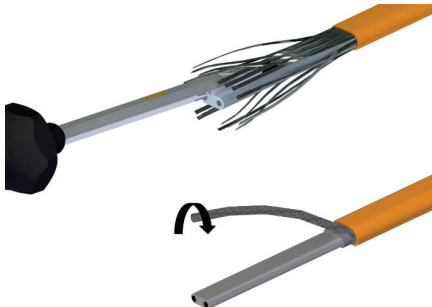

Remove 1 1/2" (40 mm) of the insulating jacket.

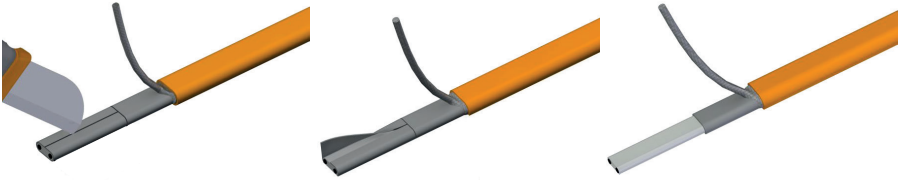

Make a small cut over and under each bus wire. Take care not to damage the bus wires.

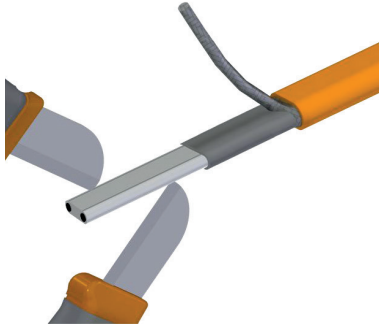

Carefully make an incision into the edges of the heating matrix. Take care not to damage the bus wires.

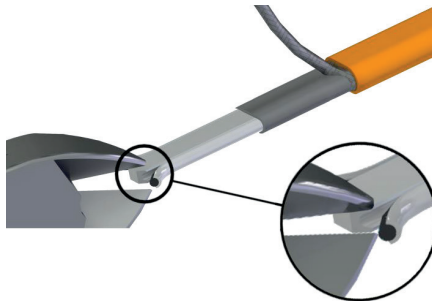

Pull off the bus wires while holding the heating matrix.

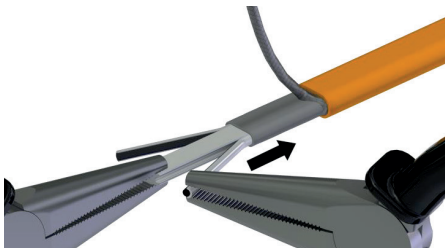

Remove any heating matrix that sticks to the bus wires.

10

Twist the bus wires.

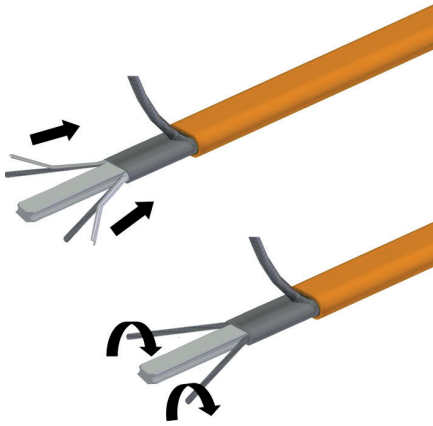

Remove the remaining heating matrix. Take care not to damage the bus wires.

11

Cut in a triangle ($\frac{1}{4}$ " (5 mm)) between the bus wires.

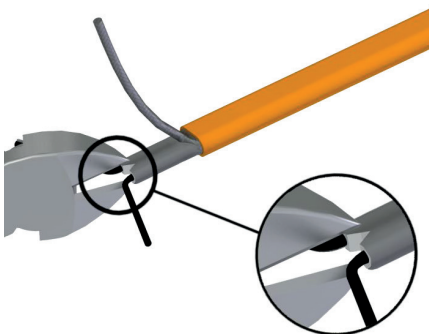
12

⚠ CAUTION:

Risk of burns. Beware of hot surfaces when using the heat gun.

⚠ ATTENTION:

Risque de brûlures. Faites attention aux surfaces chaudes en utilisant le décapeur thermique.

Slide the bus wire heat shrink tubes (no. 4) all the way onto the bus wires.
Shrink the tubes at a temperature of 275 °F / 135 °C.

13

NOTICE

For achieving a tube's temperature of 135 °C, the heat gun may be set to 250 °C setpoint (depends on Manufacturer / Model) and may be held at a distance of approximately 10 mm to the heat shrink tubes. Take care for moving circumferentially to achieve perfect shrink process on the entire tubes. All tubes are equipped with glue, which is melt by the heat shrinking. Observe the glue is squeezing out on both ends of the tubes and on full circumference.

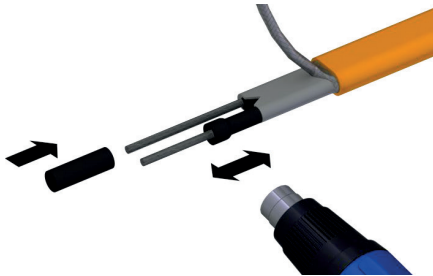

14

Slide the outer heat shrink tube (no. 5) over the end of the trace heater.
Leave a gap of 1/4" (5 mm) to the outer jacket.

Shrink the tube at a temperature of 275 °F / 135 °C.

While still hot, compress the tube between the bus wires using pliers and hold for 5 seconds.

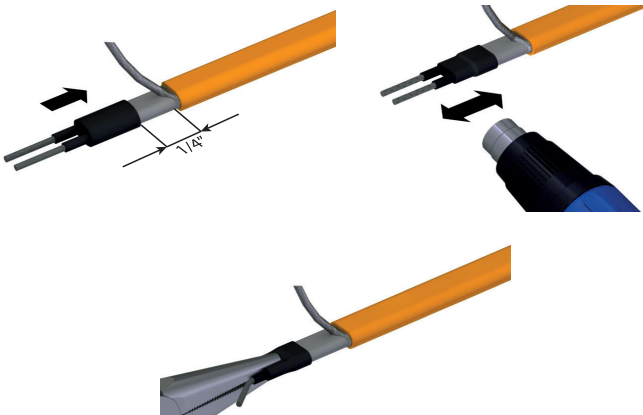

Repeat steps 3-14 for both trace heaters.

Trace heater to trace heater connection

Slide the outer protection heat shrink tube (no. 8) the final covering heat shrink tube (no. 7) and the connection covering heat shrink tube (no. 6) onto the first trace heater.

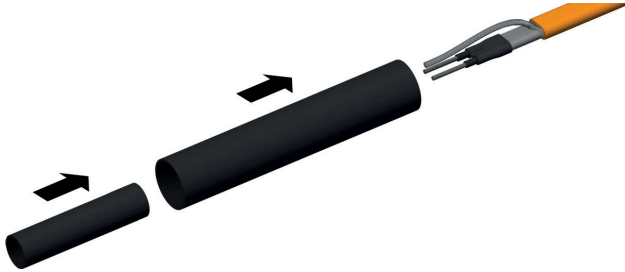
15

Slide a ferrule (no. 3) onto both of the bus wires.

16

Crimp on the ferrules using square-crimp crimping pliers.

17

Repeat steps 16-17 for both trace heaters.

Slide the bus wire splice lugs (no. 1) all the way onto the bus wires and crimp them on.

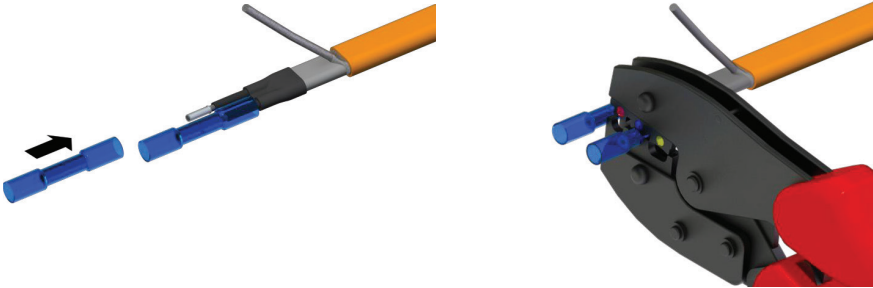
18

Now, slide the bus wires of the second trace heater all the way into the bus wire splice lugs and crimp them on.

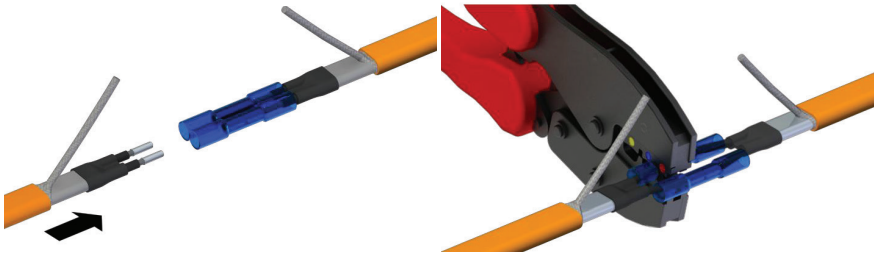
19

Shrink the red heat shrink tubes of the bus wire splice lugs at a temperature of 275 °F / 135 °C until the adhesive oozes out.

20

If one of the outer heat shrink tubes (no. 5) opens up while shrinking, compress it again using pliers and hold for 5 seconds.

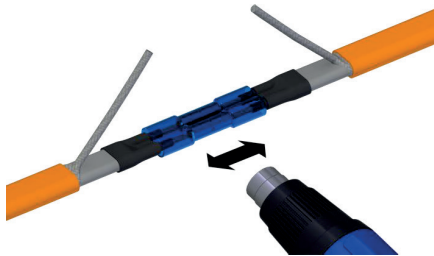

Slide the connection covering heat shrink tube (no. 6) onto the crimp connection. Make sure to leave 3/8" / 10 mm of space between the heat shrink tube and the outer jacket.

21

Shrink the tube at a temperature of 275 °F / 135 °C.

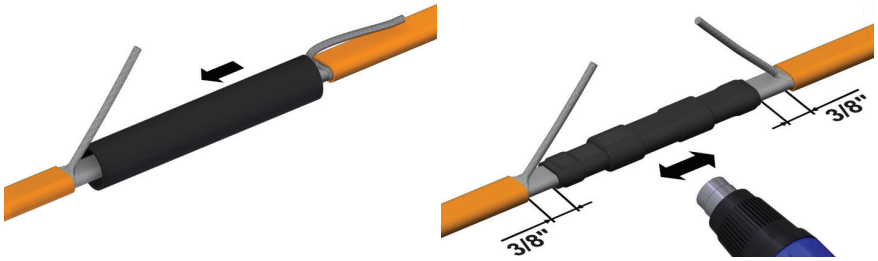

Shorten the twisted shielding braid on both sides to 2 1/2" (65 mm).

22

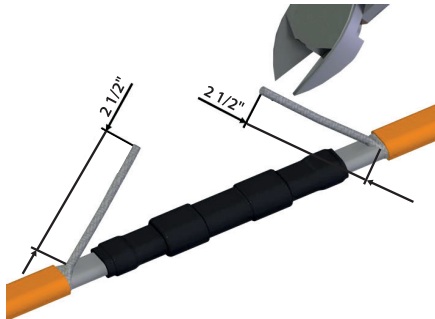

Slide the splice lug (no. 1) all the way onto the twisted grounding braid of one of the trace heaters.

23

Now, slide the twisted grounding braid of the other trace heater into the other end of the splice lug. Crimp on the splice lug on both sides using the flat crimping pliers.

Shrink the tube at a temperature of 275 °F / 135 °C.

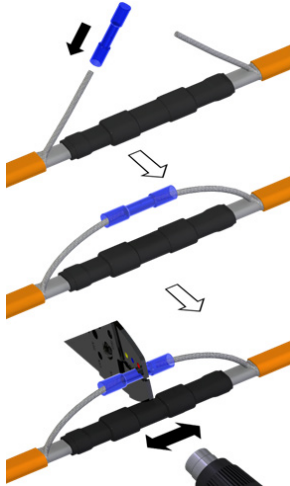

Slide the final covering heat shrink tube (no. 7) onto the connection.

24

Shrink the tube at a temperature of 275 °F / 135 °C.

Repeat the steps with the Outer protection heat shrink tube (no. 8)

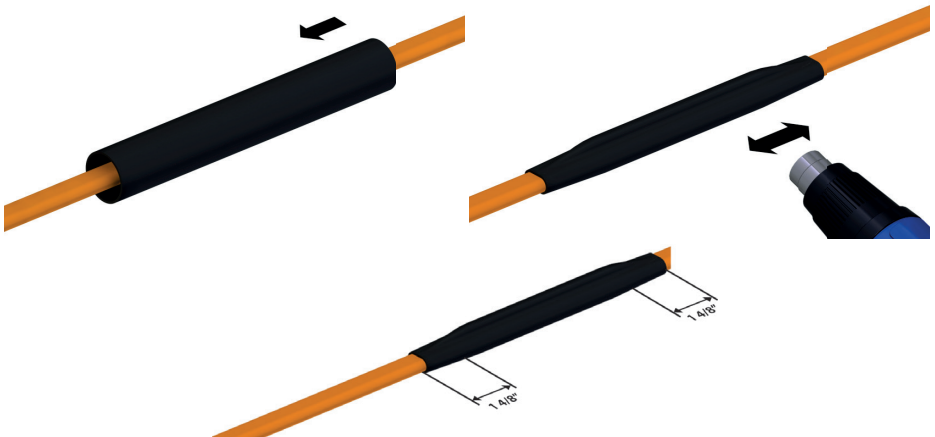

Preparation of the cold lead cable

Remove 3" (75 mm) of the outer jacket on the end of the cold lead cable.

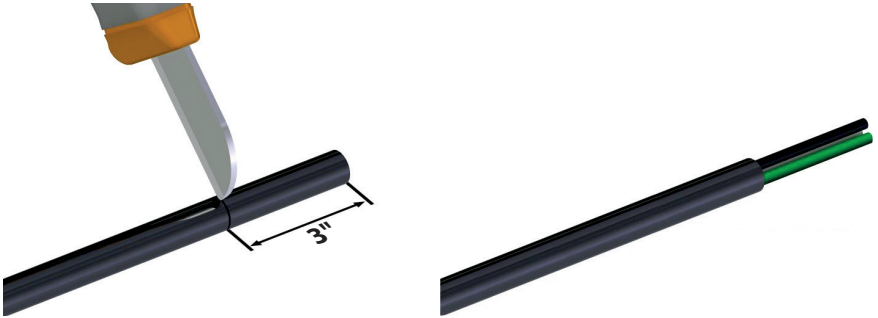
25

Remove 5/8" (15 mm) of the insulation of the bus wires and the grounding conductor.

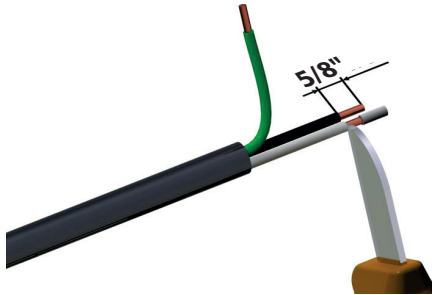
26

Cold lead cable to trace heater connection

Slide the outer protection heat shrink tube (no.8) the final covering heat shrink tube (no. 7) and the connection covering heat shrink tube (no. 6) onto the trace heater.

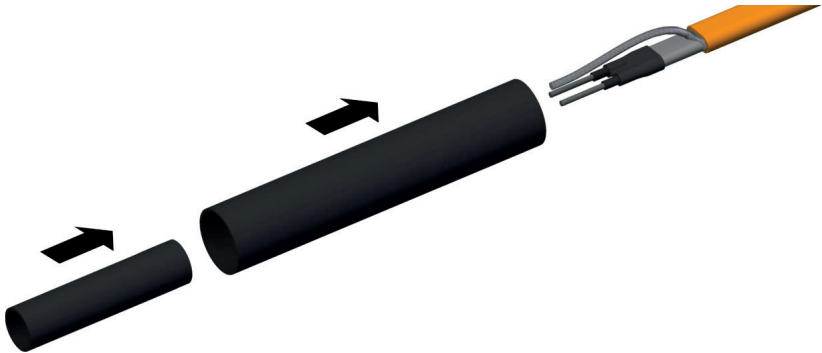
27

Slide a ferrule (no. 3) onto both of the bus wires.

28

Crimp on the ferrules using square-crimp crimping pliers.

29

Slide the bus wire splice lugs (no. 1) all the way onto the bus wires and crimp them on.

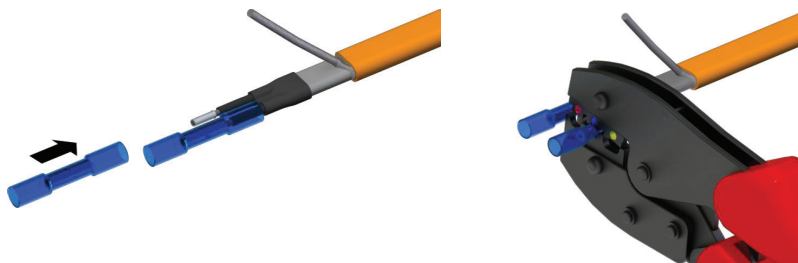
30

Now, slide the bus wires of the cold lead cable all the way into the bus wire splice lugs and crimp them on.

31

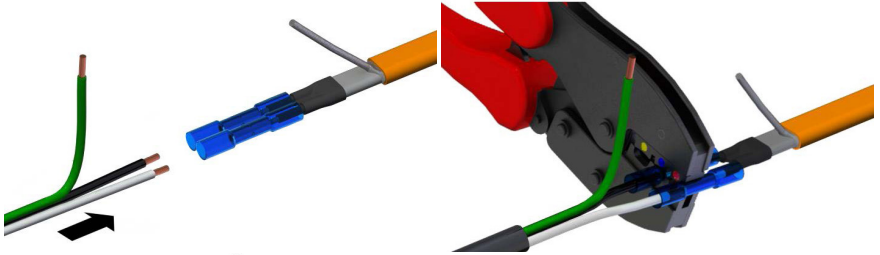

Shrink the blue heat shrink tubes of the bus wire splice lugs at a temperature of 275 °F / 135 °C until the adhesive oozes out.

32

If the outer heat shrink tube (no. 5) opens up while shrinking, compress it again using pliers and hold for 5 seconds.

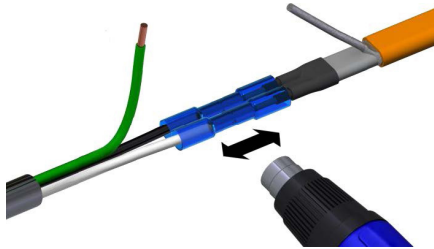

Slide the connection covering heat shrink tube (no. 6) onto the crimp connection. Make sure to leave 3/8" / 10 mm of space between the heat shrink tube's ends and the outer jacket.

33

Shrink the tube at a temperature of 275 °F / 135 °C.

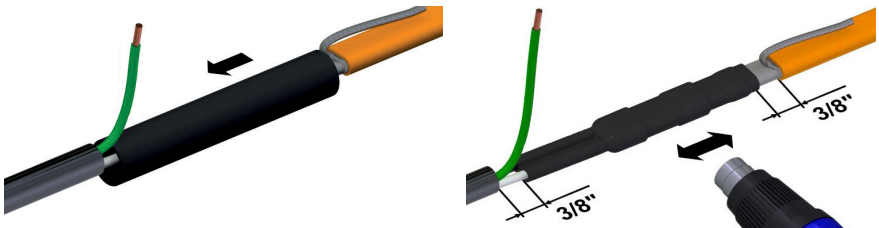

Shorten the twisted shielding braid to 2 1/2" (65 mm).

34

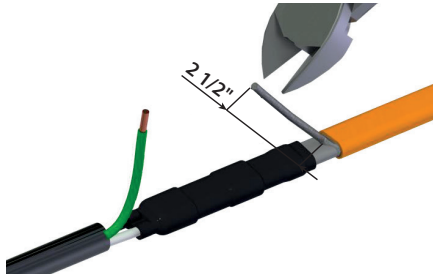

Slide the splice lug (no. 1) all the way onto the twisted grounding braid of one of the trace heaters.

35

Now, slide the twisted grounding braid of the other trace heater into the other end of the splice lug.

Crimp on the splice lug on both sides using the flat crimping pliers.

Shrink the tube at a temperature of 275 °F / 135 °C.

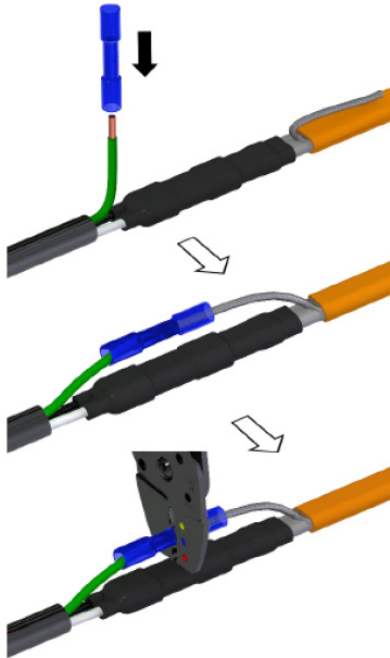

Slide the final covering heat shrink tube (no. 7) onto the connection.

Shrink the tube at a temperature of 275 °F / 135 °C.

Repeat the steps with the Outer protection heat shrink tube (no. 8).

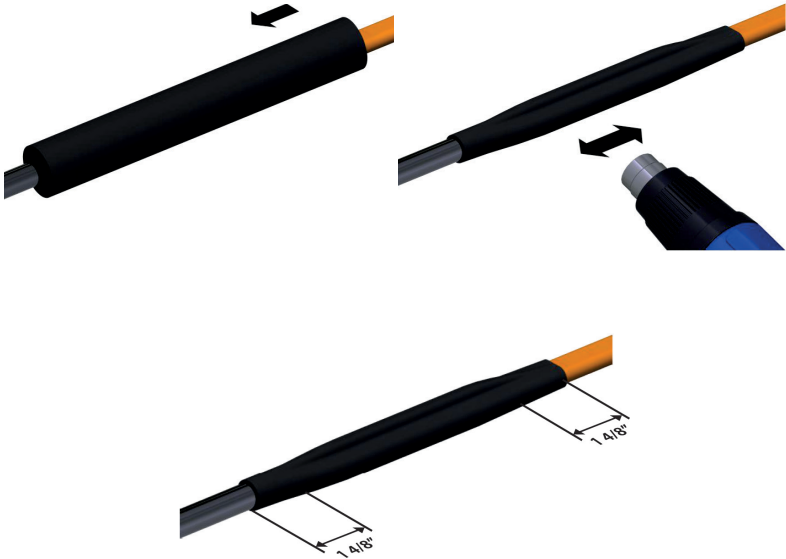
36

Installation of the end seal

Cut the trace heater off straight.

37

Remove 1 1/4" (30 mm) of the outer jacket on the trace heater.

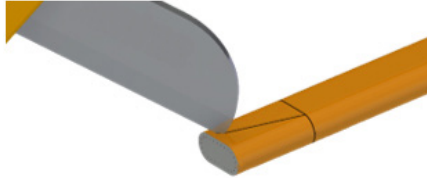

Remove the exposed grounding braid. Make sure that the insulation jacket is not damaged.

38

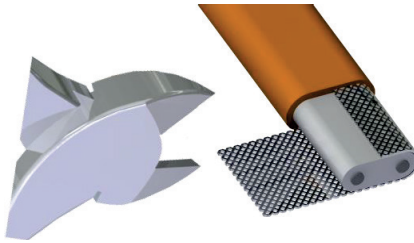

Cut in a triangle (3/8" (5 mm)) between the bus wires.

39

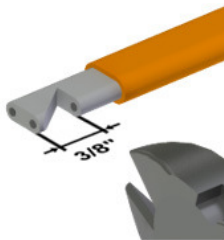

Put the inner heat shrink tube for the end-termination (length: 3/4" (19 mm); diameter: 1/2" (12 mm) over the end of the trace heater.

Leave an overlap of 3/8" (10 mm).

Beginning at the end of the cable, shrink the tube at a temperature of 275 °F / 135 °C.

While still hot, compress the end of the tube using pliers and hold for 5 seconds.

40

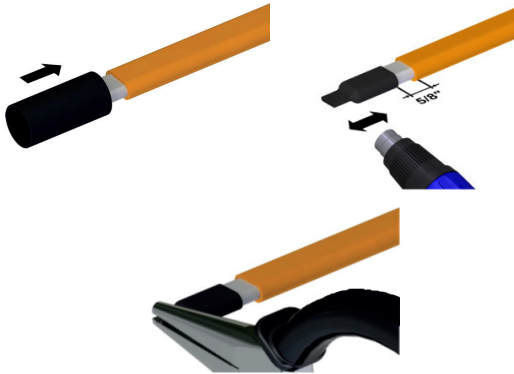

NOTICE

For achieving a tube's temperature of 135 °C, the heat gun may be set to 250 °C setpoint (depends on Manufacturer / Model) and may be held at a distance of approximately 10 mm to the heat shrink tubes. Take care for moving circumferentially to achieve perfect shrink process on the entire tubes.

All tubes are equipped with glue, which is melt by the heat shrinking. Observe the glue is squeezing out on both ends of the tubes and on full circumference.

Now, put the outer heat shrink tube (length: 3 1/8" (80 mm); diameter: 3/4" (19 mm)) over the end of the trace heater. **41**

Make sure that it overlaps the bared part of the trace heater for 3/4" (19 mm).

Beginning at the end of the cable, shrink the tube at a temperature of 275 °F / 135 °C.

Fold over the overlapping end of heat shrink tube 3/8" (10 mm).

Slightly press the end using pliers.

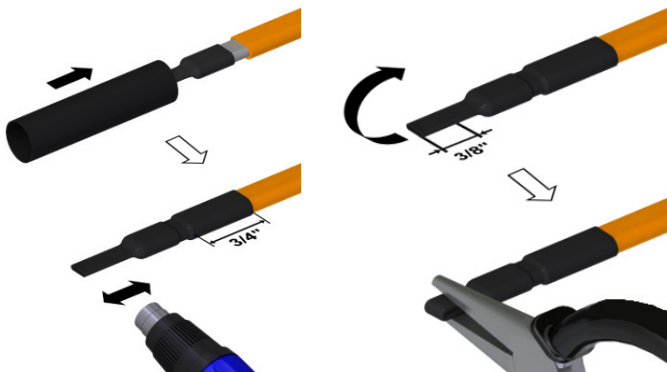

Now, put the first protection heat shrink tube (length: 2 1/3" (60 mm); diameter: 3/4" (19 mm) over the end of the trace heater.

Leave a gap to the outer heat shrink tube of 3/4" (19 mm).

Beginning at the end of the trace heater, shrink the tube at a temperature of 275 °F / 135 °C.

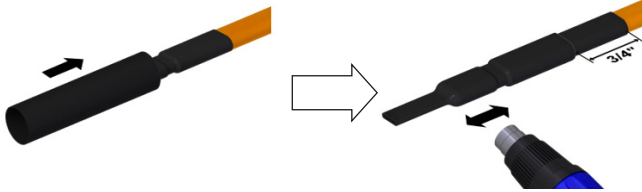

Fold over the overlapping end of the heat shrink tube 3/8" (10 mm).

Slightly press the end using pliers.

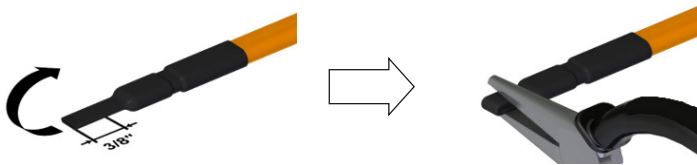

Now, put the second protection heat shrink tube (length: 2 1/3" (60 mm); diameter: 3/4" (19mm)) over the end of the trace heater.

Leave a gap to the very first heat shrink tube of 3/8" (10 mm).

Beginning at the end of the trace heater, shrink the tube at a temperature of 275 °F / 135 °C.

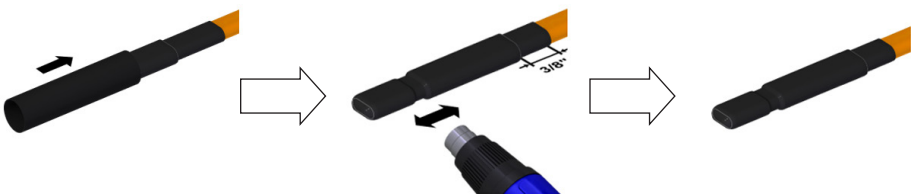

8 Troubleshooting

Problem	Possible cause	Remedy
Trace heater remains cold	No power supply	Check the supply line
	Trace heater or cold lead cable not properly connected	Connect the trace heater and cold lead cable according to the installation instructions
	Control unit adjusted incorrectly	Adjust the control unit according to the installation instructions
Automatic circuit breaker disengages	Automatic circuit breaker defective	Replace the automatic circuit breaker
	Automatic circuit breaker has wrong tripping characteristics, e. g. "B" instead of "C"	Install an automatic circuit breaker with Type-C tripping characteristics
	Nominal circuit breaker size is insufficient	Install an automatic circuit breaker with higher capacity (Observe the maximum amperage of all components of the trace heating circuit!)
	Maximum heating circuit length has been exceeded	Split the heating circuit into separate circuits
	End seal has not been installed	Install the end seal according to the installation instructions
	Short circuit	Identify the cause and remedy the fault (e. g. ensure that tape tails are not twisted)
	Humidity inside the connection system or end seal	Replace the connection system / end seal
Ground fault protection is disengaged	Trace heater damaged	Replace the trace heater at the point where it is damaged
	Moisture in the junction box	Dry the junction box. Be sure that the conduit drain is installed and breathing properly
	Ground fault protection defective	Replace the ground fault protection device(s)

9 Safety

For safe installation and operation of the cold applied connection system the technical requirements and instructions given in this manual must be followed.

⚠ WARNING

Risk of fire or electrical shock. Follow these guidelines to avoid personal injury or material damage.

- All electrical systems and installations must comply with Danfoss requirements and be installed in accordance with the relevant electrical codes and any other applicable national and local codes.
- The US and Canadian electrical codes require ground fault protection to be provided for all trace heating circuits.
- Install the connection system and trace heaters carefully.
- Note that the design guide that comes with each trace heater contains further important information and must be followed in addition to this manual.
- Use the trace heater and connection system in accordance with the intended purpose and strictly comply with the operational data specified in section Technical Data.
- The bending radius of the trace heater must be at least 1" (25 mm). Do not bend on the narrow axis.
- Any defective component of the kit must be replaced before installation.
- To avoid short circuits, do not connect the trace heater bus wires together.
- Keep all components and the trace heaters dry before and during installation.
- Beware of hot surfaces when using the heat gun.
- Keep these instructions for future reference. If applicable, leave them with the end user.
- De-energize before installation or servicing.
- Use only original accessories.

Preparation of the trace heater

⚠ WARNING

Risk of fire or electrical shock. De-energize all power circuits before installation or servicing. Always use ground fault equipment within the heat tracing system.

- Double-check that all power circuits are de-energized before you begin your work.
- Make sure that you do not exceed the maximum heating circuit length for the trace heater type you use. Refer to the system manual of the heating system.



⚠ WARNING

Risk of electrical shock and material damage. The gland body and grommet for PX/RX trace heaters are slightly different. Make sure to use the cable gland kit that fits the trace heater you use.

⚠ WARNING

Risk of burns. Beware of hot surfaces when using the heat gun.

10 Sécurité et avertissements

Afin de garantir la sécurité lors de l'installation et de l'utilisation du système de connexion par technique de thermorétraction Danfoss, il est impératif de respecter les exigences techniques ainsi que les consignes mentionnées dans le présent manuel.

⚠ AVERTISSEMENT

Risque d'incendie ou d'électrocution. Suivez ces consignes pour éviter toute blessure ou dommage matériel.

- Tous les systèmes et installations électriques doivent satisfaire aux exigences imposées par la société Danfoss et doivent être installés conformément aux normes électriques en vigueur ainsi qu'aux autres prescriptions nationales et locales applicables.
- Les normes électriques américaines et canadiennes imposent une protection contre les défauts à la terre pour tous les circuits de traçage électrique.
- La pose du système de connexion et des câbles chauffants doit être réalisée avec le plus grand soin.
- Utilisez le câble chauffant et le système de connexion adaptés à l'usage prévu et répondant aux caractéristiques de fonctionnement spécifiées à la section Caractéristiques techniques.
- Le rayon de courbure du câble chauffant ne doit pas être inférieur à 1" (25 mm). Ne pas courber le câble chauffant sur la tranche.
- Tout élément défectueux dans le kit doit être remplacé avant l'installation.
- Pour éviter un court-circuit, ne jamais raccorder ensemble les deux conducteurs du câble chauffant.
- Conservez tous les éléments et les câbles chauffants au sec avant et pendant l'installation.
- Le câble de liaison froide doit être conforme aux exigences locales et être constitué de fils AWG 16 au minimum.
- Soyez prudent lors de l'utilisation du pistolet à air chaud, certaines surfaces peuvent devenir brûlantes.
- Chaque circuit chauffant doit être clairement identifié par un moyen permanent mentionnant le nom du fabricant, le type de circuit, sa puissance et sa tension.
- N'employez jamais de ruban adhésif en vinyle, même en complément de ce kit.
- Conservez ces instructions pour un usage ultérieur. Le cas échéant, remettez-les à l'utilisateur final.
- Mettre hors tension avant toute installation ou opération de maintenance.
- Utilisez exclusivement des pièces et accessoires d'origine Danfoss.

Avertissements et mises en garde

⚠ AVERTISSEMENT

Risque d'incendie ou de choc électrique. Éteignez tous les circuits d'alimentation avant l'installation ou l'entretien. Toujours utiliser un équipement de défaut à la terre dans le système de traçage thermique.

- Vérifiez bien que tous les circuits électriques sont hors tension avant de débiter votre travail.
- Veillez à ne pas dépasser la longueur de circuit de traçage maximale autorisée pour le type de câble chauffant utilisé. Consultez à ce sujet le guide de conception du système de traçage.



⚠ AVERTISSEMENT

Risque d'électrocution et/ou de dommages matériels. Le corps du presse-étoupe et le passe-fil destinés aux câbles chauffants PX/RX sont légèrement différents. Prenez donc garde à bien utiliser le corps du presse-étoupe et le passe-fil adaptés au câble chauffant utilisé.

⚠ AVERTISSEMENT

Risque de brûlure. Soyez prudent lors de l'utilisation du pistolet à air chaud, certaines surfaces peuvent devenir brûlantes.

ENGINEERING
TOMORROW



Danfoss

11655 Crossroads Circle
Baltimore, MD 21220 USA
Phone: 1-888-DANFOSS (326-3677)
Fax: 416-352-5981
lx.danfoss.com

Danfoss A/S

Climate Solutions • danfoss.us • +1 888 326 3677 • heating.cs.na@danfoss.com

Any information, including, but not limited to information on selection of product, its application or use, product design, weight, dimensions, capacity or any other technical data in product manuals, catalogues descriptions, advertisements, etc. and whether made available in writing, orally, electronically, online or via download, shall be considered informative, and is only binding if and to the extent, explicit reference is made in a quotation or order confirmation. Danfoss cannot accept any responsibility for possible errors in catalogues, brochures, videos and other material. Danfoss reserves the right to alter its products without notice. This also applies to products ordered but not delivered provided that such alterations can be made without changes to form, fit or function of the product.

All trademarks in this material are property of Danfoss A/S or Danfoss group companies. Danfoss and the Danfoss logo are trademarks of Danfoss A/S. All rights reserved.
