

**PALLADIO**  
BY REFPOWER

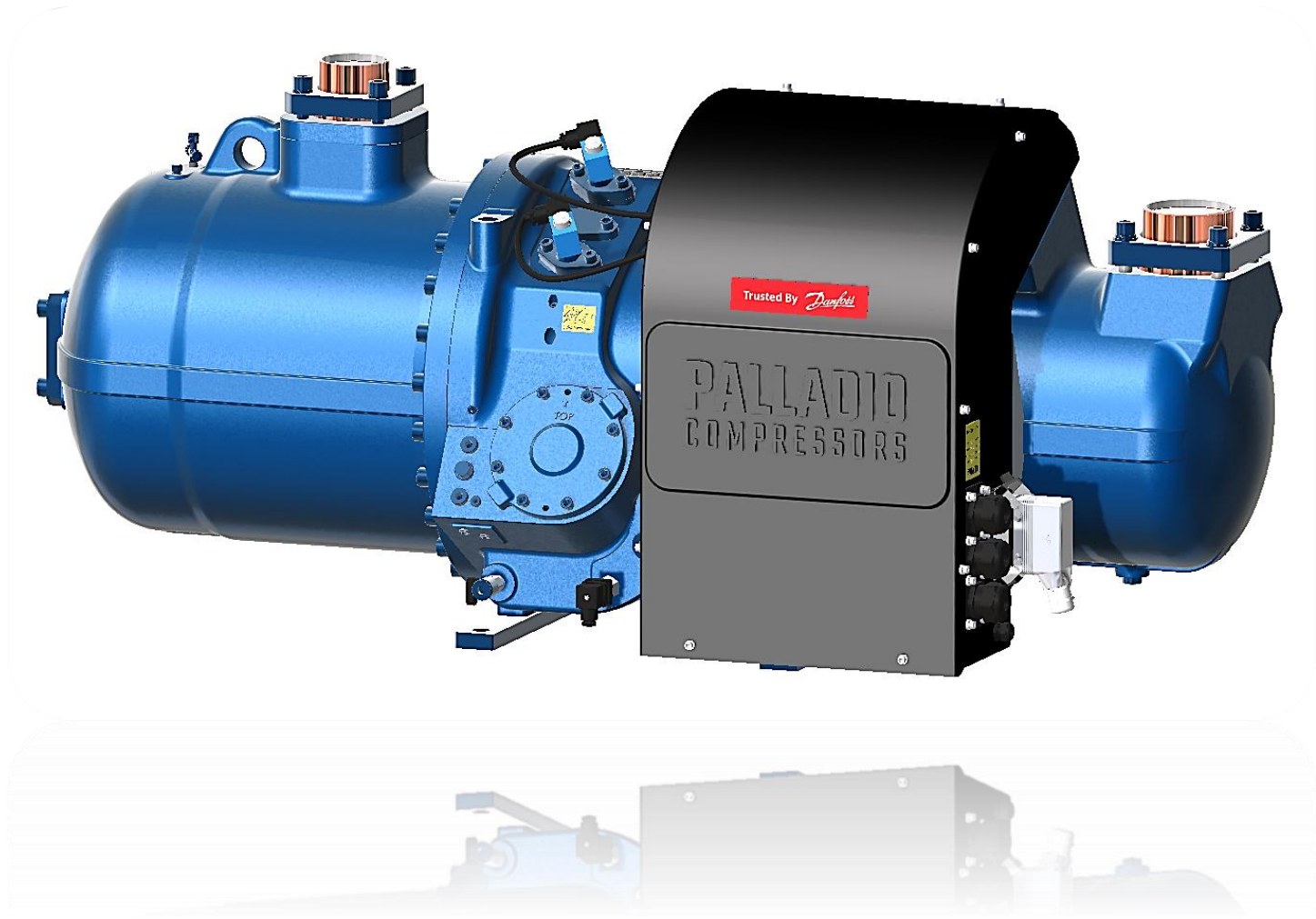

## **Palladio Compressors – K1 Series**

*Use and Maintenance Manual*



ENGLISH  
Rev. 01

# *Palladio Compressors – K1 Series*

## *Index*

1. GENERAL INFORMATION AND SAFETY
2. PACKAGING, OPENING AND HANDLING
3. MODELS AND TECHNICAL DATA
4. ENVELOPE
5. INSTALLATION AND START UP
6. INVERTER
7. LUBRICATION
8. ADDITIONAL COOLING
9. REGULAR MAINTENANCE
10. WEIGHTS AND OVERALL DIMENSIONS

# *Palladio Compressors - K1 Series*

## *1. General Information and Safety*

- 1.1. INTRODUCTION
- 1.2. LEGEND SIMBOLOGY
- 1.3. SAFETY
- 1.4. NAMEPLATE
- 1.5. COMPRESSION PROCESS

### 1.1 INTRODUCTION

The present manual deals with PALLADIO screw compressors K1 series. The K1 series is composed of semi-hermetic twin-screw compressors for refrigeration systems. Compressors are provided with an integrated inverter for the electrical motor, a compression system composed by a male and a female rotor (where male rotor is directly coupled to electrical motor) and an oil separator. The K1 series compressors are designed and built in order to be incorporated in a refrigeration plant complying with European Directive 2006/42/EC.

### 1.2 LEGEND SIMBOLOGY

The present manual uses the following symbols.

Correct application or proper practice to be performed to avoid malfunction or damage of the compressor.

	<b>Note</b>
---	-------------

Safety recommendation to avoid major damage to the compressor or the personnel involved in installation and maintenance.

	<b>Important note</b>
---	-----------------------

### 1.3 SAFETY

The compressor is a partly completed machine; compressor is built in compliance with laws and international standards in force, EN 12693. All informations supplied by the actual manual and by specific technical Information shall be carefully abided by.

#### 1.3.1 Installation area and personnel

The installation plant of the compressor shall be built complying:

- main safety standards (EN 378-2);
- European directive in force;
- National regulations specific of the country of installation.

Personnel operating on compressors of the K1 series shall be properly trained on European regulations, National regulations and all instructions provided by the compressor manufacturer.

#### 1.3.2 Safety devices

The compressor is equipped with internal safety valves to prevent high pressure to exceed maximum admitted pressure written on the nameplate of the compressor. These devices are not subjected to the final user check. During special maintenance activities, these devices shall be controlled.

All safety and control devices of the compressor do not replace the safety devices required by the regulations for cooling circuits or heat pumps where the compressor is installed.

### 1.4 NAMEPLATE

The compressor nameplate contains the following listed data.

1. manufacturer and production site
2. compressor type
3. item code
4. production date
5. serial number
6. maximum running currents
7. displacement

①

<b>MADE IN ITALY</b>		Compressor Type		Item code	
 Lonigo - VICENZA - ITALY		②		③	
		Production date		Serial Number	
		④		⑤	
cod.5YL0004A					
V 3Ph~	Hz	Max running current	LP/HP max.	Max displacement	IP
380 ÷ 440	50/60	⑥ A	19/25	⑦ m <sup>3</sup> /h	54

Figure 1A: nameplate

### 1.5 COMPRESSION PROCESS

The compression process is carried out, as shown in the following figure, in three steps:

1. Suction phase: the screws open a volume between teeth and trap the refrigerant at low pressure in the compression chamber.
2. Compression phase: the screws gradually reduce the volume of trapped refrigerant between teeth and increase the pressure of the refrigerant.
3. Discharge phase: the screws definitely reduce the volume and push the refrigerant out of the compression chamber; the refrigerant gets the maximum plant pressure which depends on the working condition of the plant.

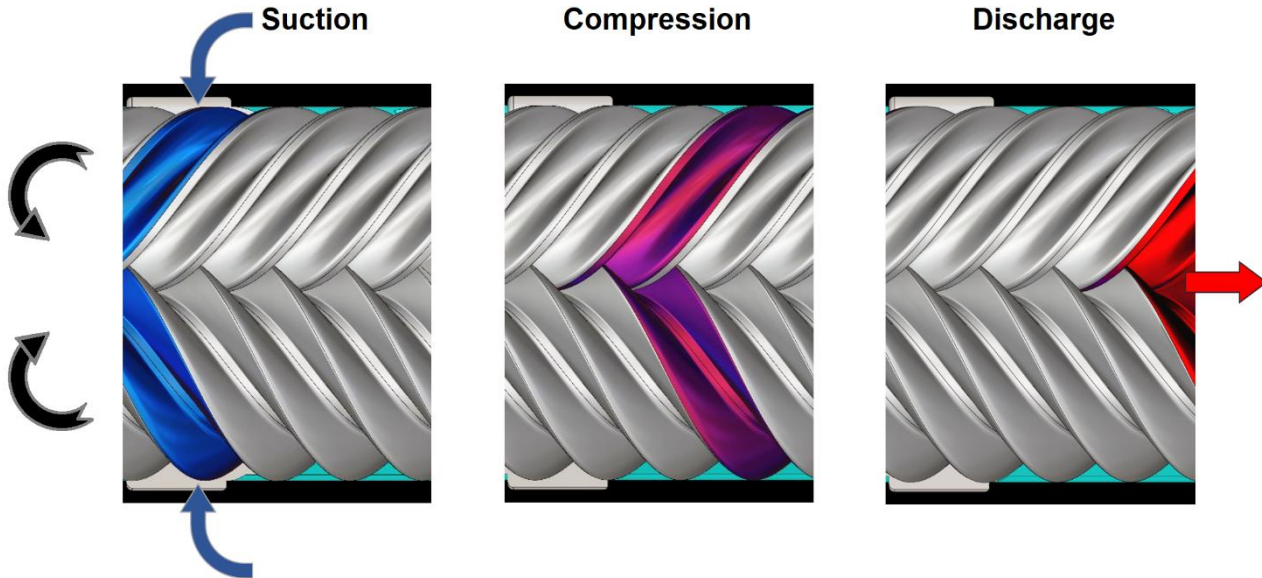

Figure 1B: compression process

# *Palladio Compressors – K1 series*

## *2. Packaging, Opening and Handling*

- 2.1. STORAGE
- 2.2. PACKAGE OPENING
- 2.3. HANDLING

## 2.1 STORAGE

The compressor is supplied with the necessary oil charge for operation. In order to prevent inlet of wet air or dust and acidification of lubricant, the compressor is provided with a charge of dry nitrogen at a pressure equal to 1,5bara (22psia).



### Note

The compressor should be stored in a storage room at ambient temperature to avoid an increasing of internal nitrogen pressure.

Discharge of nitrogen should be done from discharge shut-off valve: open slowly the shut-off valve and let nitrogen come out. It is recommended not to leave ambient air in the compressor for more than 30 minutes.

## 2.2 PACKAGE OPENING

The compressor package is composed as follows:

- a pallet of adequate dimensions on which the compressor is fitted by screws through the holes of fixing feet;
- a wood box of adequate dimensions that covers the compressor; the box is fixed on pallet by staple points.

To unpackage the box it is necessary to break the staple points and lift the box up vertically to avoid hurting the compressor surface. Then, unscrew the screws fitted on fixing feet. After these operations, the compressor may be lifted up from pallet.



### Important note

During the activities of compressor unpackaging, the worker should use personal protective equipments such as gloves and glasses to prevent any injuries from wood splinters.

## 2.3 HANDLING

The handling of the compressor fitted on the pallet should be carried out by a lift truck: check the capacity of lift truck which must be adapted to lift the weight of the compressor.

The handling of the compressor should be carried out by lines, belts or chains whose capacity must be adequate to the compressor weight. Fit snap-hooks, shackle hooks or hooks provided by safety lock in loops of cast iron on bodies of the compressor. It is possible to use a rocker arm to move the compressor in horizontal direction and to keep belts for lifting in vertical direction.

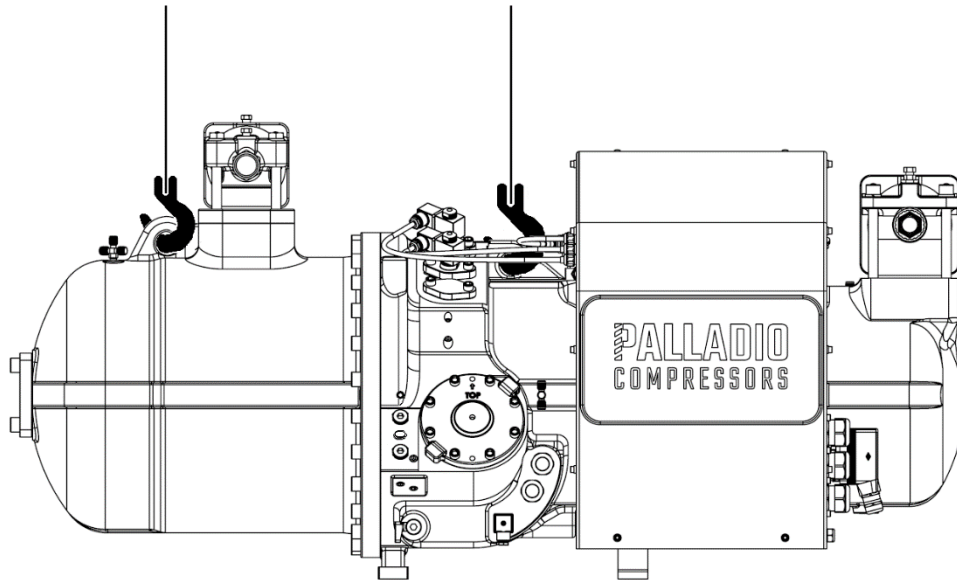

Picture 2A: handling of the compressor by belts hanging on a rocker arm.



If it is not possible to use a rocker arm, apply belts or chains which must be long enough to let the lifting in the horizontal direction: in this case check the capacity of the belts and the chains which must be adequate to the weight of the compressor multiplied by the factor of increasing due to the inclination of belts

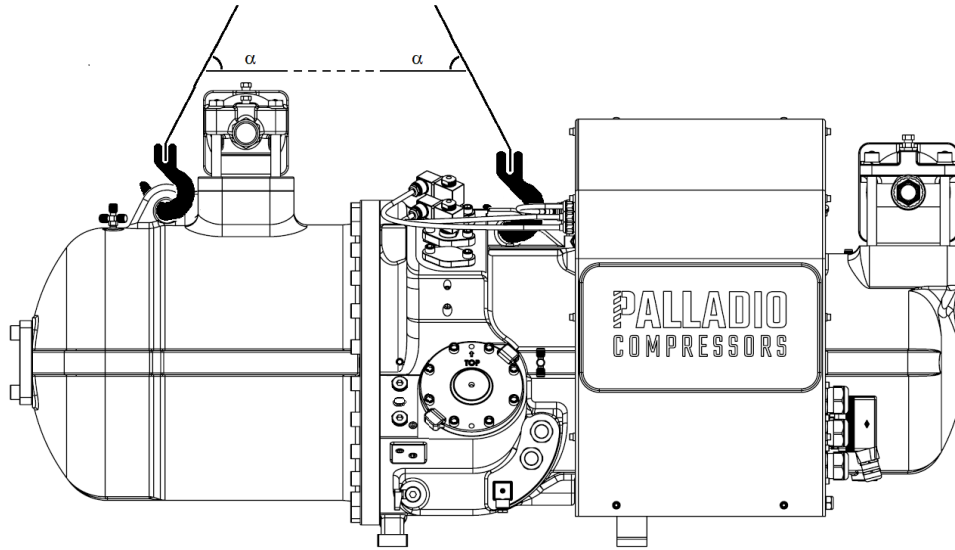

Picture 2B: The compressor handling by oblique belts

The below table gives an indication of the multiplicative coefficient of the compressor weight as a function of the inclination of the lifting belts or chains.

ANGLE $\alpha$	COEFFICIENT	ANGLE $\alpha$	COEFFICIENT
90°	1	45°	1.414
85°	1.004	40°	1.556
80°	1.015	35°	1.743
75°	1.035	30°	2
70°	1.064	25°	2.366
65°	1.103	20°	2.924
60°	1.155	15°	3.864
55°	1.221	10°	5.759
50°	1.305	5°	11.474

	<p><b>Note</b></p> <p>Only qualified personnel shall carry out the handling of the compressor by lift truck or by haul system and belts.</p>
--	--

	<p><b>Important note</b></p> <p>During the compressor handling, personnel should keep an adequate clearance from the compressor to avoid risks due to accidental fall of the compressor.</p>
--	--

# *Palladio Compressors - K1 Series*

## *3. Models and Technical Data*

3.1. MODELS

3.2. TECHNICAL DATA

### 3.1 MODELS

The product code meaning of K1 series models is explained as follows:

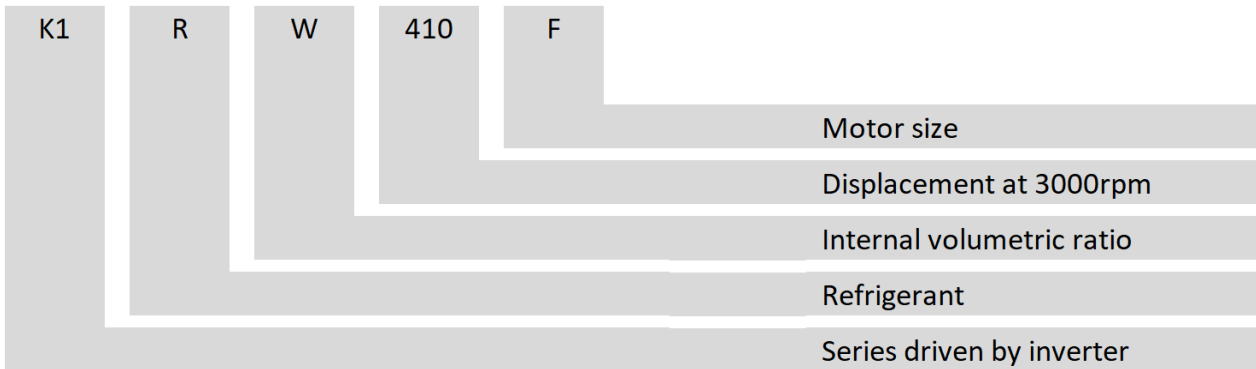

### 3.2 TECHNICAL DATA

MODELS	MINIMUM DISPLACEMENT	MAXIMUM DISPLACEMENT	WEIGHT*	MOTOR FLA	DIMENSIONS L X H X W	SUCTION CONNECTION	DISCHARGE CONNECTION	OIL CHARGE
	m <sup>3</sup> /h	m <sup>3</sup> /h						
K1_410S	164	578	860	215	1564 x 774 x 730	104,8	80	18
K1_480S	192	672	872	215				
K1_560S	224	784	890	215				
K1_640S	256	896	1108	289	1748 x 830 x 760			22
K1_720S	288	1008	1108	289				
K1_810S	324	1127	1108	289				

\* The weight is to be considered for compressor without shut-off valves

# *Palladio Compressors - K1 Series*

## *4. Envelope*

- 4.1. APPLIED REFRIGERANTS
- 4.2. SAFETY GROUP A2L REFRIGERANTS

#### 4.1 APPLIED REFRIGERANTS

The following refrigerants can be applied to K1 series compressors:  
R134a, R1234yf; R1234ze; R513A.

SINGLE-COMPONENT REFRIGERANTS		
REFRIGERANTS NUMBER	PREFIX OF COMPOSITION DESIGNATION	SAFETY GROUP
R134a	HFC	A1
R1234yf	HFO	A2L
R1234ze	HFO	A2L

BLENDS		
REFRIGERANTS NUMBER	NOMINAL COMPOSITION IN MASS FRACTION %	SAFETY GROUP
R513A	R-1234yf/134a (56,0/44,0)	A2L/A1

Table 4A e 4B: composition and safety group of applied refrigerants

In case of additional refrigerants belonging to the safety group A1 and A2L, refer to RefPower Srl in order to know the proper envelope.

#### 4.2 USE SAFETY GROUP A2L REFRIGERANTS

The safety refrigerant class is defined according to the standards ISO 817:2014 and ASHRAE 34. Standard delivery K1-series compressors cannot be applied with A3 safety class refrigerants.

	<p><b>Importante note</b></p> <p>The standard delivery compressor is not designed in accordance with ATEX 2014/34/EU for use in ATEX areas (defined by ATEX 99/92/EC).</p>
--	--

	<p><b>Importante note</b></p> <p>The compressor, all standard sensors and equipments are not designed for operations in areas with a risk of explosion and they must be installed in areas which are not classified according to the Directives 1999/92/EC and 2014/34/EU and according to the Annex I of EN 378-2.</p>
---	---

	<p><b>Note</b></p> <p>The use of A2L safety class refrigerants must comply with the European directives, regulations and laws which are in force in the country of installation of the cooling system. Safety signs shall be provided where necessary.</p>
---	--

The cooling plant where the compressor is installed shall be in compliance with the standards for cooling plants, i. e. EN 378-2; the area where the compressor and the equipments are installed shall not be classified as hazardous area:

For example, the compressor can be installed in:

1. Outdoor areas whose installation and ventilation conditions ensure that the spaces around compressor are not classified even in case of potential damages of the compressor or of the connected plant.
2. Indoor areas or technical compartment whose forced ventilation can avoid a hazardous or explosive atmosphere.
3. Indoor areas or technical compartment equipped by gas sniffer devices in order to measure hazardous concentration of gas and to activate the forced ventilation or disactivate the compressor or any other source of ignition.

	<p><b>Importante note</b></p> <p>Use all the necessary precautions in the application of A2L safety class refrigerants; in the case of partial combustion of the refrigerant charge:</p> <ul style="list-style-type: none"> <li>• installing the compressor in an place with adequate air exchange;</li> <li>• under no circumstances do not inhale combustion products;</li> <li>• use appropriate personal protective equipment such as gloves, goggles and masks.</li> </ul>
---	---

#### 4.2.1 Refrigerant leakage control points

The main points on the compressor in order to control potential refrigerant leakage, which are not to be considered within the scope of EN ISO 14903, are listed below:

- flanges

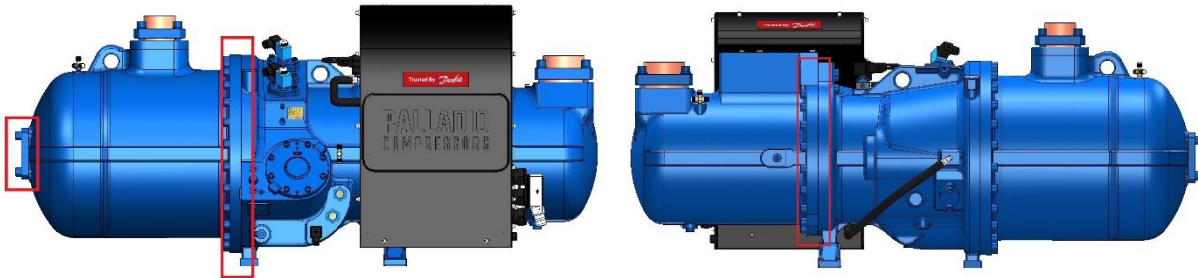

- oil filter seat

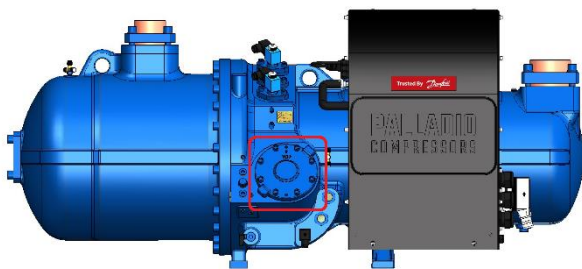

- SAE connections for pressure meters

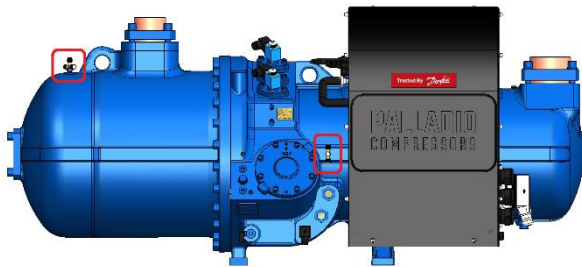

- solenoid valves for VI control and driver cooling

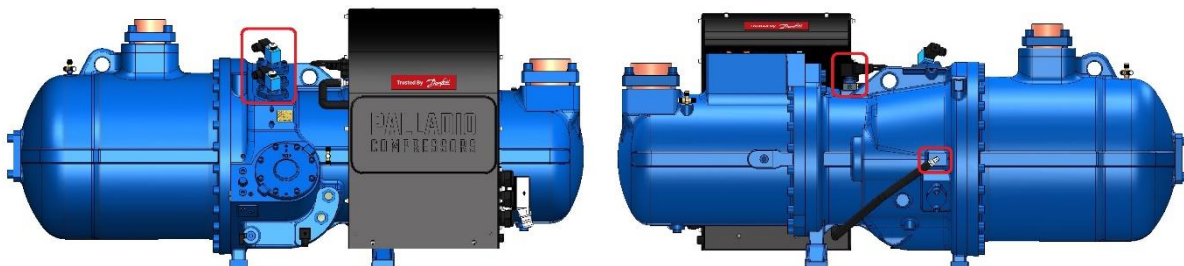

- connections for oil circuit and/or threads for closure of oil circuit

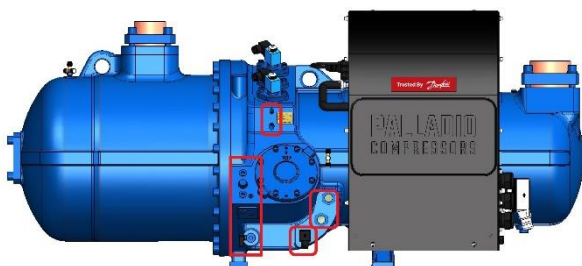

- suction shut-off valve and discharge shut-off valve

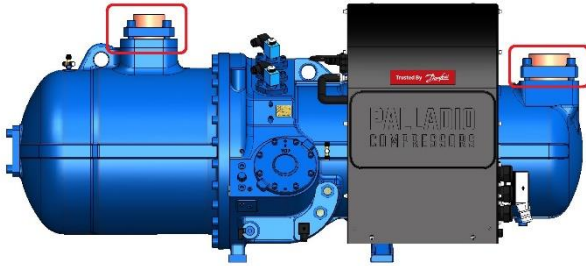

#### 4.2.2 Activities following refrigerant leakage or refrigerant combustion

- Refrigerant gases, exhausted gases and condensates of burning are harmful for the health. Ensure an adequate ventilation on the zone of the leakage or combustion in order to decrease concentration of gases, exhaust gases and to facilitate evaporation of condensates.
- Make sure that compressor is off and open the electrical box to eliminate locked gas and to facilitate evaporation of potential condensates.
- Check the operating state of electrical equipment on the compressor (electrical valves, sensors, ect.)



#### Important note

Use adequate personal protective equipment as gloves, glasses and masks to carry out maintenance activities following gas leakage or gas combustion.

# *Palladio Compressors - K1 Series*

## *5. Installation and Start Up*

- 5.1. INSTALLATION
- 5.2. CHECK BEFORE START UP
- 5.3. START UP



## 5.1 INSTALLATION

### 5.1.1 Installation area

The installation of the compressor should comply with the following recommendations:

- The K1 series compressors should be installed in horizontal position.
- The supports on which the compressor is placed should be designed in order to hold up the weight of the compressor and the forces of operation.

	<p><b>Note</b></p> <p>Do not install the compressor on inadequate supports to avoid risks of structural failure.</p>
---	--

- Before installation it is necessary to provide adequate space around the compressor to allow routine maintenance.
- The K1 series compressors are not designed to be installed in chemically aggressive and radioactive atmosphere.

	<p><b>Important Note</b></p> <p>The installations in chemically aggressive or radioactive atmospheres shall be approved by manufacturer.</p>
---	--

### 5.1.2 Fixing to the frame

- Fixing of the compressor shall be carried out by screwed connections through the specified holes.

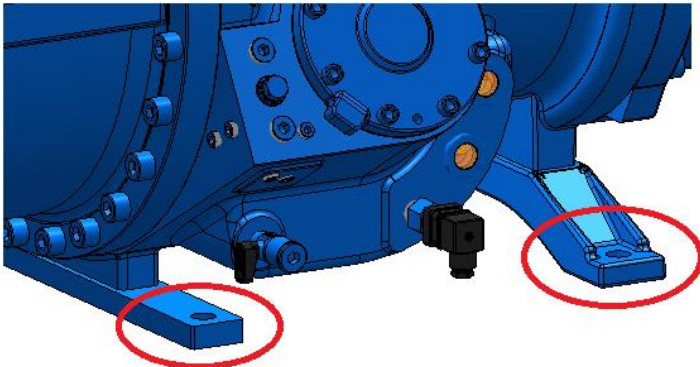

Figure 5A: holes to fix the compressor to the structure of the plant.

- In order to avoid the transmission of vibrations due to the operation, it may be necessary to place the compressor on vibration dampers. The vibration dampers are supplied as standard. The vibration dampers kit is composed as follows.

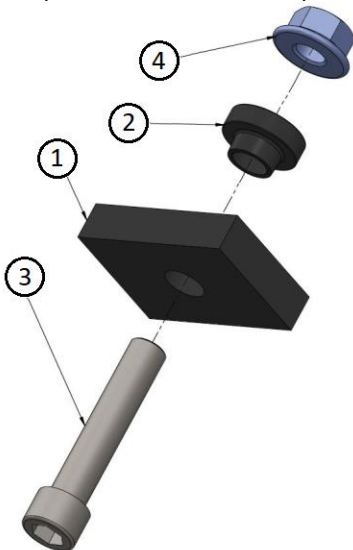

Figure 5B: vibration dampers kit

REFERENCE	DESCRIPTIONS	Q.TY
1	RUBBER PAD 50 x 70 x 15 x Ø16	1
2	DAMPER CLINCH JOINT Ø14 x 30 x 16	1
3	SCREW 12.9 TCEI M14 x 70 UNI 5931	1
4	NUT KLOCK FLANG. M14 DIN 6927 CL.8 ZN	1

- In order to perform the right assembling operation of the kit, the damper clinch joint (reference 2) shall be compressed 0,5 mm than original dimension.

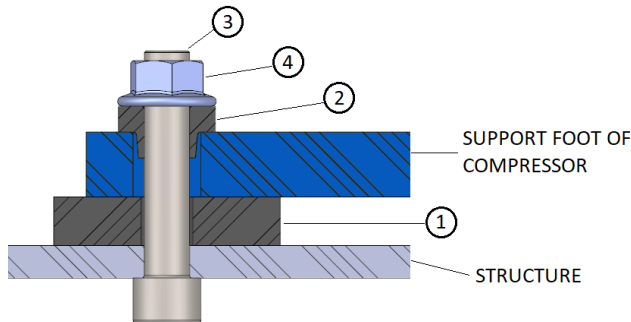

Figure 5C: assembly vibration dampers kit

### 5.1.3 Suction tube connection and discharge tube connection



**Important note**

The supplied compressors are charged with nitrogen up to 1,5bara (21,7psia). Pay attention to outlet of nitrogen: it is mandatory to open the discharge shut-off valve and to wait for the complete outlet of nitrogen from the compressor.

- The K1 series compressors are provided with pipe connections whose inside diameter is suitable for the commercial copper tubes.
- Pay attention during the activities of cutting the tubes to avoid introduction of dusts or swarfs in the tubes; do an adequate cleaning after the activities of cutting.
- Before brazing the tubes to the connections, ensure that the tubes are clean, devoid of drosses and dry.
- After brazing, wait for the complete cooling down of the brazed components to tighten them to the compressor.



**Important note**

Brazing operations may cause thermal expansion of mechanical components. The tightening of warm components to the compressor may be compromised by successive thermal reduction. Moreover thermal reduction may compromise the seal of the gaskets also.

- Before the tightening of the brazed components to the compressor, check the gaskets and remove all the thin protection discs.

### 5.1.4 Cooling supply of inverter by liquid

The K1 series compressors are provided with a solenoid valve for the cooling of the inverter. During the installation it is mandatory to connect the solenoid valve to the liquid line pipe of the cooling plant.

The features of the supply line shall be the following:

- The supply pipe at the base of the solenoid valve shall have an external diameter equal to 8 mm.
- The supply pipe line shall be connected to the liquid line of the refrigerant plant downstream the dehydrator filter.

The solenoid valve is autonomously energized by the inverter.



**Note**

The connection at the base of the solenoid valve shall be free of burrs in order to ensure the right seal of the refrigerant liquid.

Every welded connection of the supplied pipe line shall be carried out by qualified personnel.

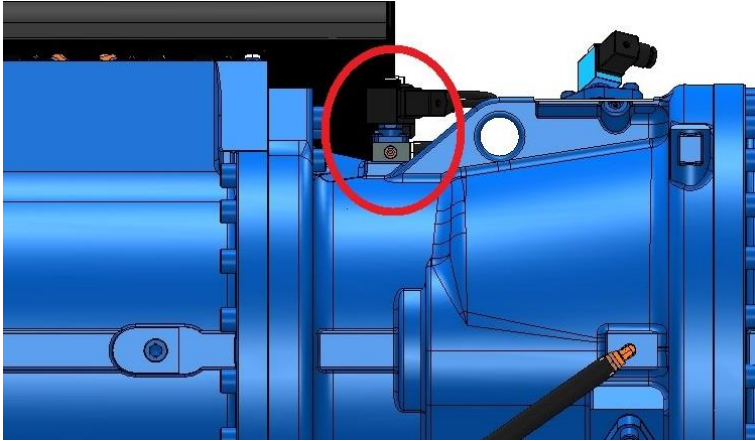

Figure 5D: solenoid valve of the inverter cooling circuit

## 5.2 CHECK BEFORE THE START-UP

Before of the compressor start-up it is necessary to execute the following activities:

- Check that the oil level is between the two oil sight-glasses;
- Place the oil heating cartridge;
- Pay attention that the oil temperature in the compressor is at least 15K higher then the outside room temperature; at this purpose turn on the heating cartridge at least 8 hours in advance;
- Make sure of the right functioning of the security devices installed on the compressor such as the pressure switches and the thermostats;
- Check that both suction and discharge shut-off valves can open when necessary.

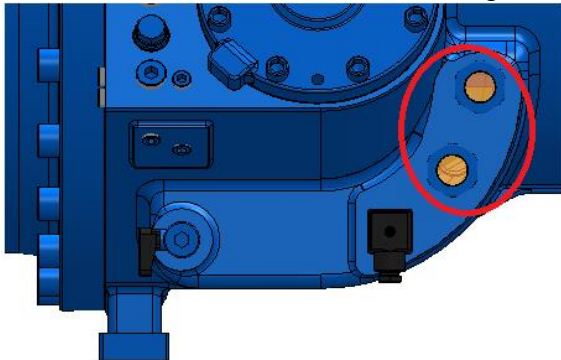

Figure 5E: Oil sight glasses for oil level control

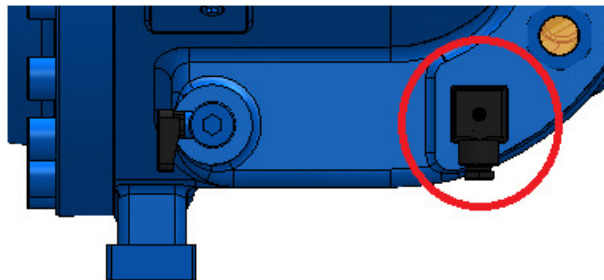

Figure 5F: Heater for oil heating

## 5.3 START-UP

### 5.3.1 Oil level

In case of the first start-up it is suggested to check the oil level:

- The level must be visible between the 2 oil sight-glasses (see Figure 5E);
- During the first start-up a foam formation is possible but when the proper working conditions are reached, the foam must be reabsorbed.



**Note**

If the foam of oil persists even after the first start-up, it will be necessary to check the refrigerant charge contained in the plant.

### 5.3.2 Discharge temperature

Once the working conditions are reached, it is suggested to check the compressor discharge temperature.



**Note**

In case of a very low compressor discharge temperature, it is possible that an excessive charge of refrigerant was charged inside the plant (for this reason it is important to observe the presence of foam through the oil sight-glasses caused by the refrigerant at liquid state dissolved in oil). In case of high discharge temperature, it is suggested to verify the suction temperature and the suction superheating.



**Important notice**

The discharge pipe, the discharge shut-off valve and the oil separator may reach very high temperatures; affix the appropriate pictograms and instructions on the high temperature parts.

# *Palladio Compressors – K1 Series*

## *6. Inverter*

- 6.1. INVERTER DESCRIPTION
- 6.2. CONNECTION OF POWER CABLES
- 6.3. CONNECTION OF CONTROL CABLE
- 6.4. PANEL OF LEDS CONTROL
- 6.5. START UP
- 6.6. STOP
- 6.7. CAPACITY CONTROL
- 6.8. SOLENOID VALVES VI CONTROL
- 6.9. SOLENOID VALVE COOLING INVERTER PLATE

### 6.1 INVERTER DESCRIPTION

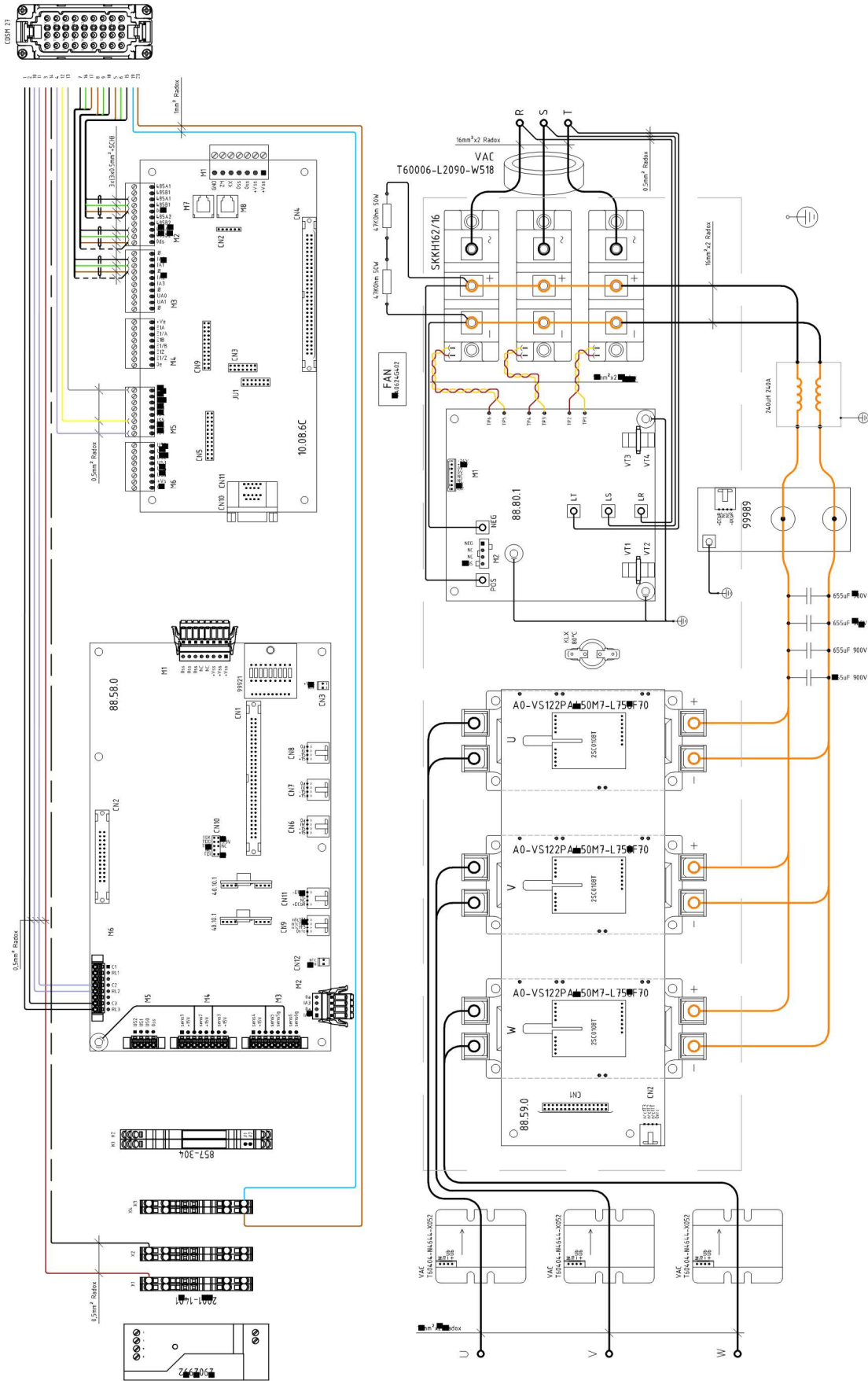

Figure 6A: inverter design

The K1 series compressors are equipped with an integrated inverter which can control the capacity of the compressor. Moreover, the inverter performs the diagnostic functions regarding the compressor. The communication between PLC and inverter can be carried out by analogous and digital signals or digital communication protocols.

## 6.2 CONNECTION OF POWER CABLES

Before connecting the cables of power supply and the ground cable, disassemble the transparent panel. The cables of the power supply shall be connected to the terminal and they shall pass through the 3 cable gland.

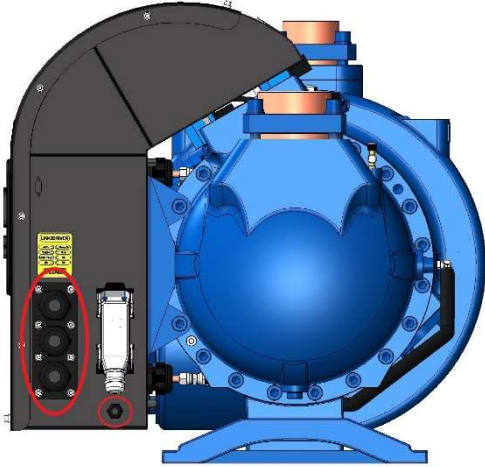

Figure 6B: cable gland for power supply cables and ground on the electrical box

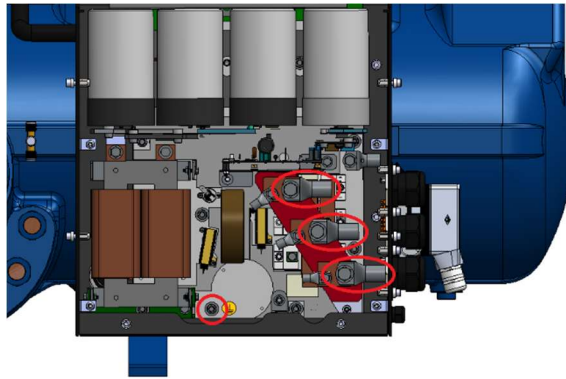

Figure 6C: clamps for power supply cables and ground on inverter



**Note**

It is not mandatory to connect the power cables to the inverter in an appropriate sequence in order to ensure the right rotation sense of the electrical motor of the compressor.

The ground cable shall be connected to the proper clip. The ground cable shall be introduced in the electrical box through the cable gland placed under terminal board.



**Note**

The cables and the terminal lug for the compressor shall be properly sized complying with the standards and the right practices in force.



**Important note**

Connect the cables to the compressor terminal block in the absence of power supply voltage. The electrical connection shall be carried out by qualified personnel.



### 6.3 CONNECTION OF CONTROL CABLE

#### 6.3.1 Connections

The multipolar cable shall be connected to the male connector CDSM placed on the electrical box. The connection position of the poles is shown by the following images and by the following table.

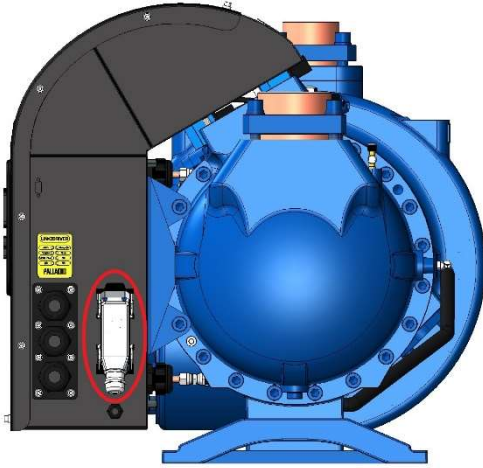

Figure 6D: connector for the control cable

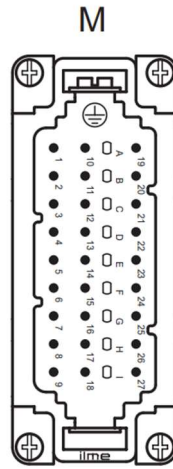

Figure 6E: male connector on electrical box

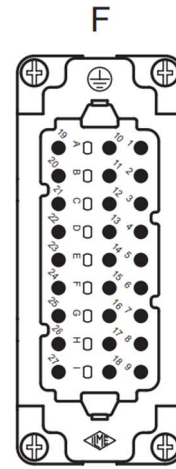

Figure 6F: female connector on signal cable

PIN	DESCRIPTION	FEATURES	FUNCTION
1	Free output contact; NO type; drive OK state	250Vac - 6A	Drive OK
2			
10	Free output contact; NO type; rotation feedback	250Vac - 6A	Rotation Feedback
11			
3	Output contact 24Vdc	24Vdc	Relay supply
14	Output contact 0Vdc	0V	
4	Free input contact; Relay to alarms reset (return from PIN 3)	Pulse relay	Reset
12	Free input contact; Relay to enable speed, start up (return from PIN 3)	Relay	Enable speed
13	Free input contact; Relay to enable drive (return from PIN 3)	Relay	Enable drive
7	Analogical input signal; reference speed; negative pin	0 Vdc	Speed reference
16	Analogical input signal; reference speed; positive pin	0 / +10 Vdc	
17	Zero point cable of analogical signal speed reference		0V
8	Zero point cable of serial communication	0V	Serial communication
9	Negative serial communication cable	RS485	
18	Positive serial communication cable		
5	Zero point cable of serial communication		
6	Negative serial communication cable		To be setted-up
15	Positive serial communication cable		
19	Input 220Vac power supply to solenoid valves and to 24Vdc generator	220Vac	Auxiliary supply
20			
⊕	Ground connection	Ground	Ground

Table 6A: description and position of poles of signals on male connector and on female connector



### 6.3.2 Features of control cable

The inverter is controlled by analogical and digital signals or by digital communication protocols thanks to the multipolar cable whose features are the following:

- multipolar cable: at least 8 poles + ground cable
- wire cross areas: 0,14 - 2,5 mm<sup>2</sup> (AWG 26 - 14)
- in case of cables crimped by a cable terminal, apply a cables section equal to 1,5 mm<sup>2</sup> (AWG 16)
- lenght of graze of cables: 9 - 11 mm

### 6.3.2 Default features for communication on RS485 bus

The default features for communication on RS485 bus are the following:

- Slave ID (p2p): 0
- Baudrate: 19200 bps
- Parity: even
- Read Timeout 1 sec

	<p><b>Note</b></p> <p>The technical properties of the communication cable as lenght, diameter, insulation and connession, shall be adequate to support the listed features above.</p>
---	---

### 6.4 LED CONTROL PANEL

The LED panel shows the working status of the inverter; function and meaning of LED are described by the following table.



Figure 6G: LED panel yellow version

LED	DESCRIPTION	LED	DESCRIPTION
+24V	Board power supply active	Motor PTC	Motor PTC Protection
Drive OK	Inverter ready, absence alarms	S4	No signal
Enable	Enable drive	S5	No signal
Run	Enable speed	S6	No signal

Table 6B: description of control LEDs regarding status of inverter

### 6.5 START UP

The start-up of the K1 series compressors shall be carried out by the following sequence of phases:

- switch on the power main switch
- power supply which the inverter needs is 230Vac (see table 6A, PIN 19 and PIN 20)
- switch on contact "Enable drive" (see table 6A, PIN 13)
- switch on contact "Enable speed" (see table 6A, PIN 12)



**Note**  
The main power switch shall be properly selected in compliance with the actual laws in force. Refer to the technical data of the compressor to select the right size of the switch.

Once the previous phases are performed, the inverter reaches the first level of the rotational speed which is equal to the minimum speed (Jog1)

**6.5.1 Compressor equipped with fixed intrinsic compression ratio (fixed VI)**

Once the minimum speed is reached, the inverter checks the following:

- suction pressure
- oil pressure
- discharge pressure
- pressure difference from discharge to suction

Once performed the check, the inverter reaches the set point of the rotational speed which is required by the analogical signal 0-10Vdc (see table 6A, PIN 7 and PIN 16) or by the digital communication protocol (see table 6A).



Figura 6H: logical sequence of complete compressor start-up procedure

### 6.5.2 Compressor equipped with variable intrinsic compression ratio (variable VI)

Once the minimum speed is reached, the inverter performs the following checks:

- suction pressure
- oil pressure
- discharge pressure
- pressure difference from discharge to suction

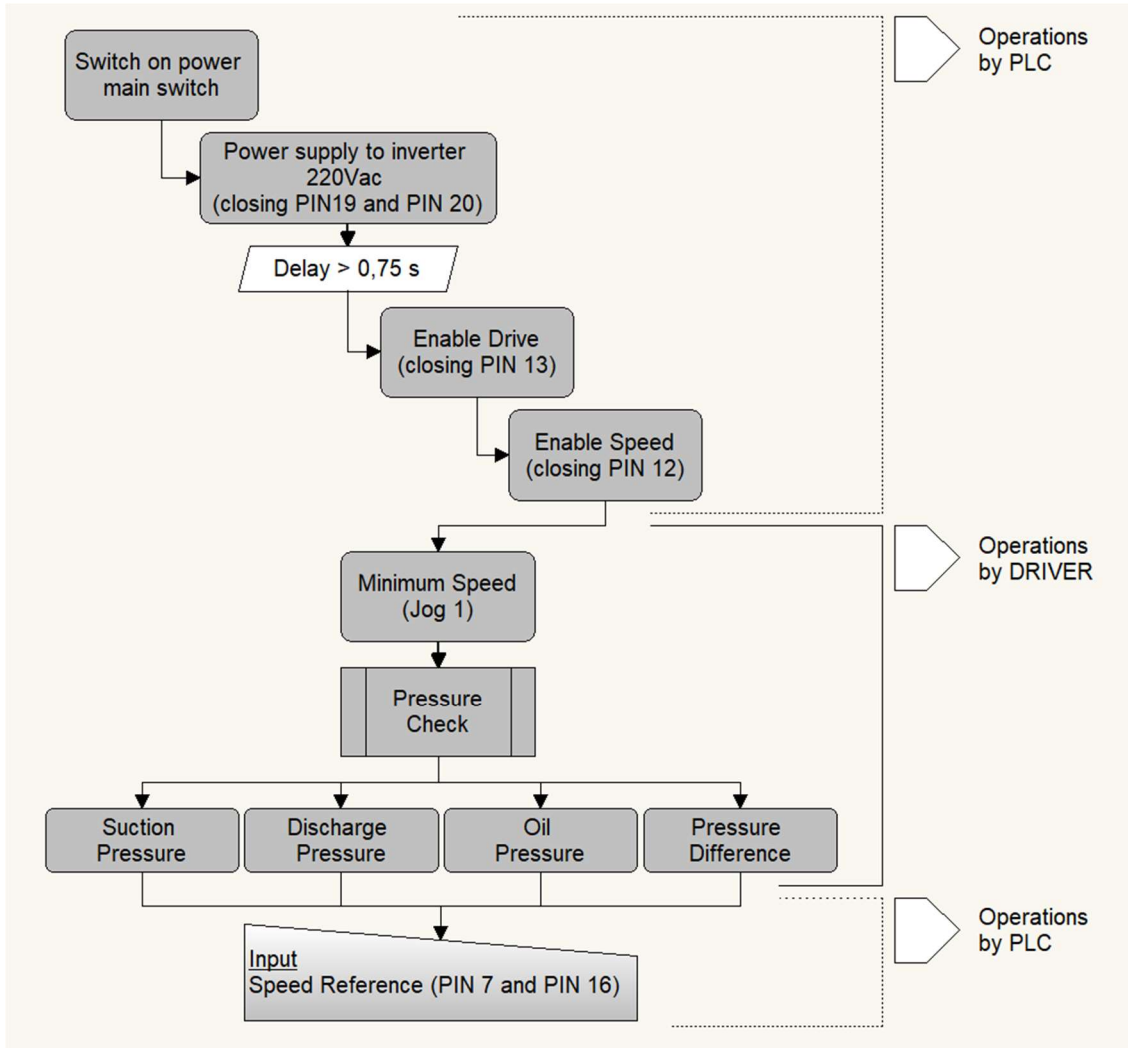
Once performed the check, the inverter reaches the second set point of rotational speed and searches the first optimal VI at the actual working conditions. Once the optimal VI is reached, the inverter reaches the set point of rotational speed required by analogical signal 0-10Vdc (see table 6A, PIN 7 and PIN 16) or by the digital communication protocol (see table 6A).



Figura 6I: logical sequence of complete compressor start-up procedure

## 6.6 STOP

### 6.6.1 Shut down

The following sequence is the appropriate sequence of instructions in order to shut down the compressor.

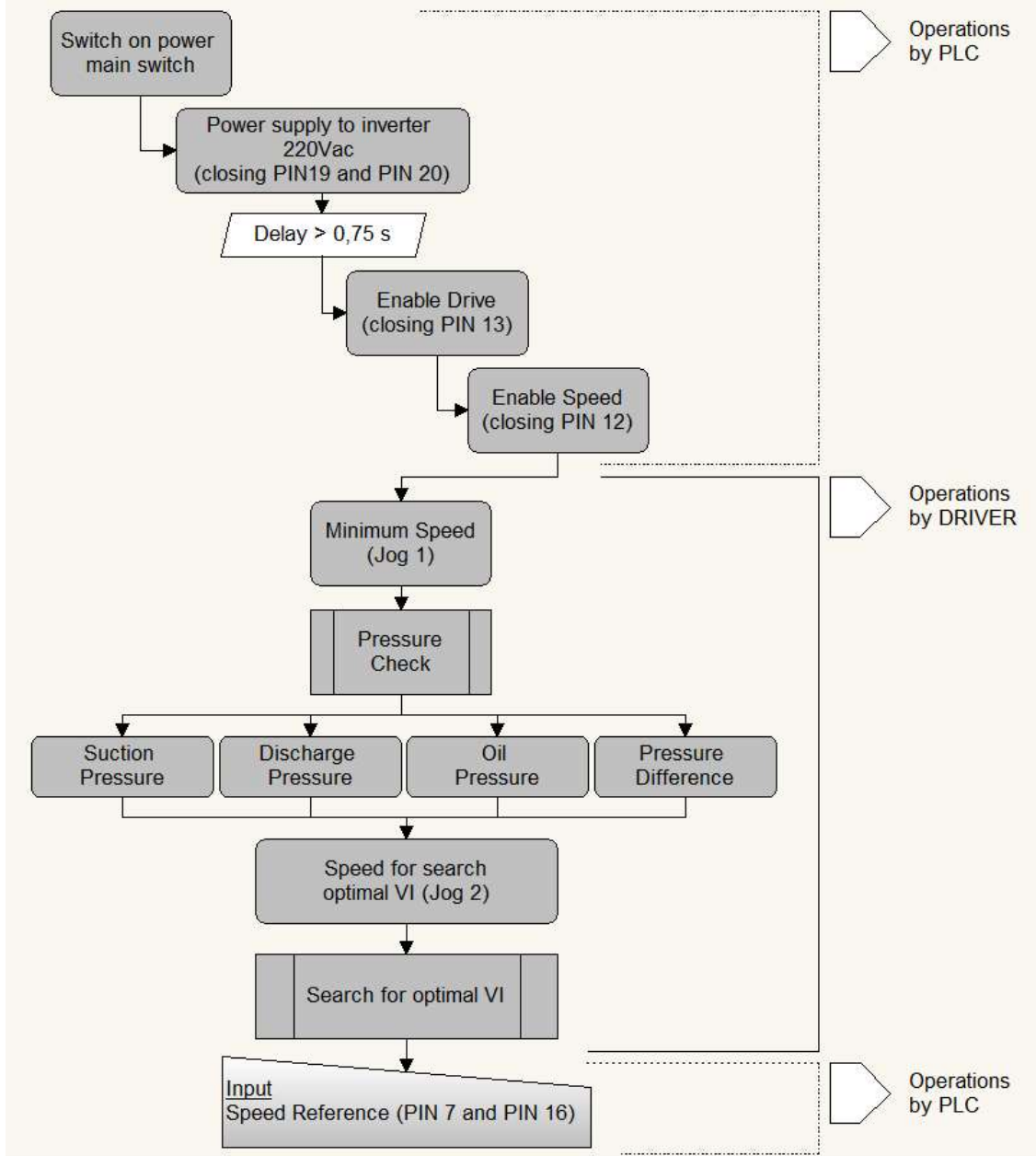

Figura 6L: logical sequence of compressor shut down

### 6.6.2 Stop speed

It is possible to stop the compressor rotational speed and to keep compressor on, by opening PIN 12 only.

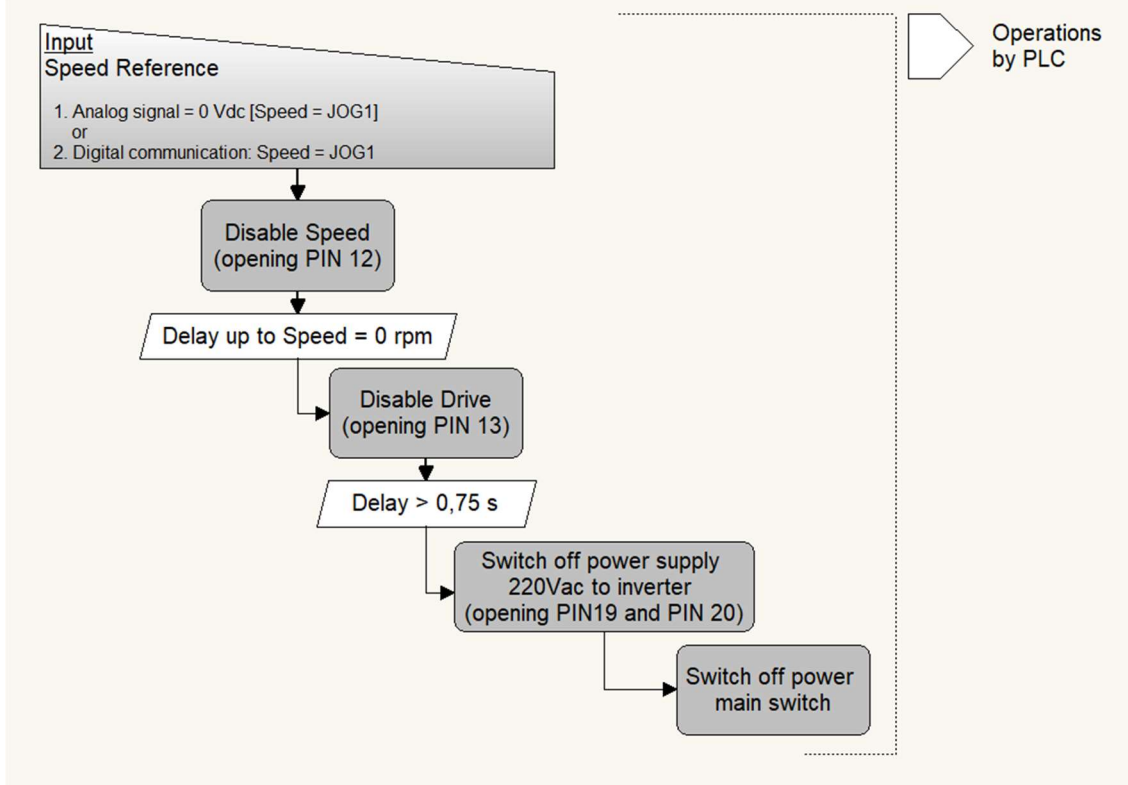

Figura 6M: logical sequence of rotational speed stop

## 6.7 CAPACITY CONTROL

The control of the capacity of the K1 series compressor equipped with integrated inverter is performed by:

- analogical signal in continuous voltage 0 – 10 Vdc supplied by PLC of the refrigeration plant;
- digital communication protocols supplied by PLC of the refrigeration plant.

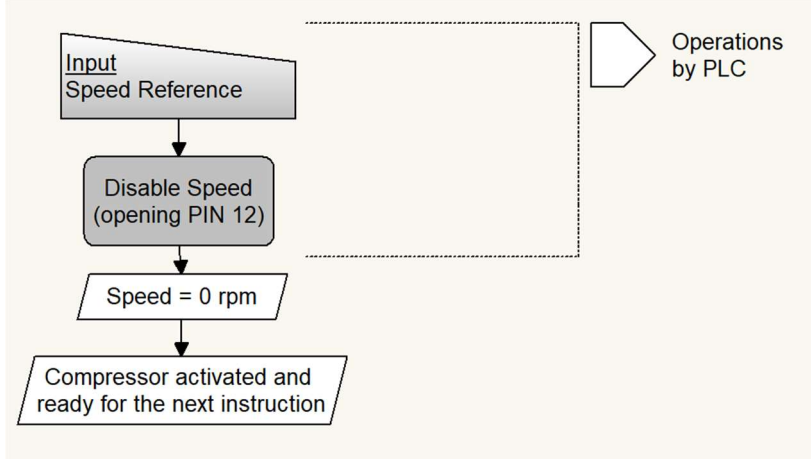
Connection terminals of the analogical signal cables are shown on paragraph 6.3 of the present manual.

### 6.8 SOLENOID VALVES VI CONTROL

The compressors K1 series may be equipped with solenoid valves to control VI; the valves perform their function of search and control of the optimized VI. The function is autonomously and automatically carried out in all compressor operation phases.

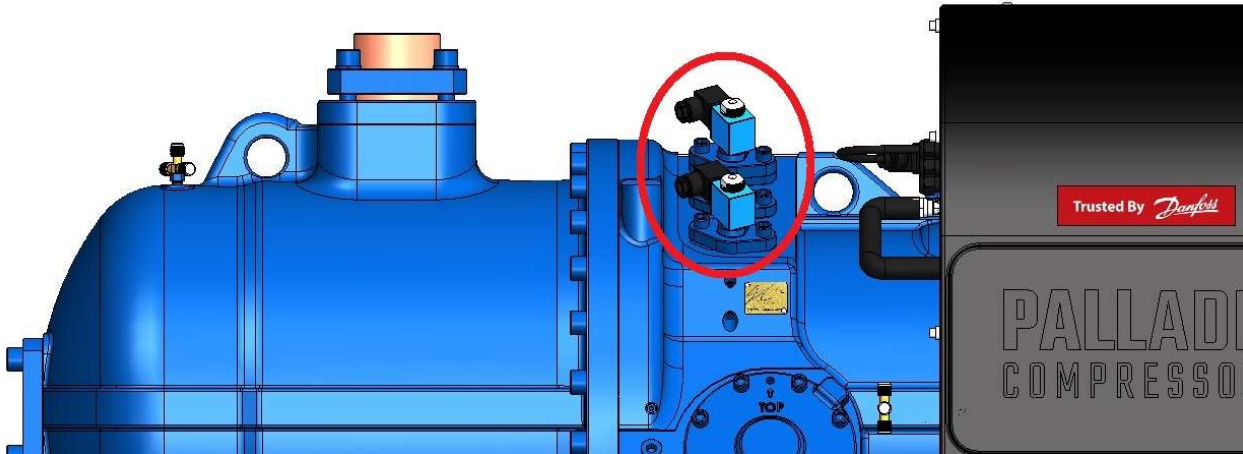

Figure 6N: solenoid valves for VI control

### 6.9 SOLENOID VALVE COOLING INVERTER PLATE

The K1 series compressors are equipped with solenoid valves for cooling the inverter. The K1 series compressors autonomously and automatically perform this function in all compressor operation phases. Refer to paragraph 5.1 of the present manual for installation of the proper pipe.

# *Palladio Compressors - K1 Series*

## *7. Lubrication*

- 7.1. LUBRICATION FUNCTION
- 7.2. LUBRICANT LEVEL
- 7.3. STANDARD SUPPLY
- 7.4. OPTIONAL SUPPLY
- 7.5. LUBRICANT FLOW-RATE
- 7.6. OIL COOLING
- 7.7. OIL HEATING
- 7.8. OIL FILTER

### 7.1 LUBRICATION FUNCTION

The lubrication and the oil circuit control ensure the following functions:

- mechanical sealing between screws and compression chamber;
- lubrication of bearings;
- cooling.



**Note**

It is proper to carry out periodical maintenance by checking the oil circuit and the oil circuit components in order to ensure the circuit function. Refer to chapter 10.

### 7.2 LUBRICANT LEVEL

The lubricant level shall be visible through the sight glasses placed at the right side of the oil filter.

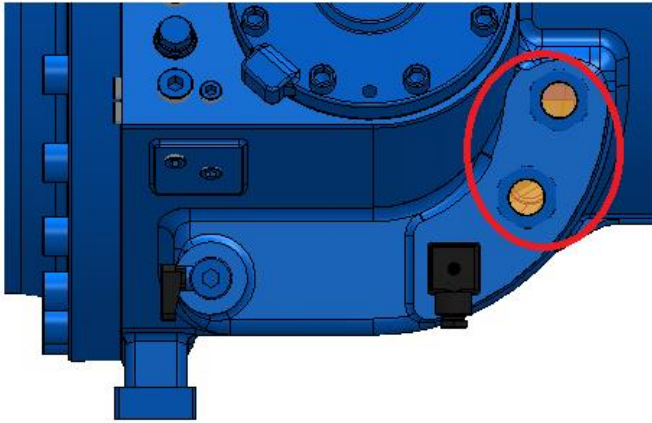

Figure 7A: oil sight glass to check level.

The oil foam can appear on the oil surface during transient working or during the start-up of the compressor. Make sure that the oil foam is not present during stable working conditions.

### 7.3 STANDARD SUPPLY

The standard supply is composed by 2 grub screws and by an hexagonal head screw. The grub screws and the hexagonal head screw are assembled on the compressor.

Moreover, 2 brass nipples (SAE and NPT thread 1/2") and a long cylindrical head screw are supplied as standard for the lubricating circuit interception. The nipples and the long cylindrical head screw are not assembled on the compressor as standard.

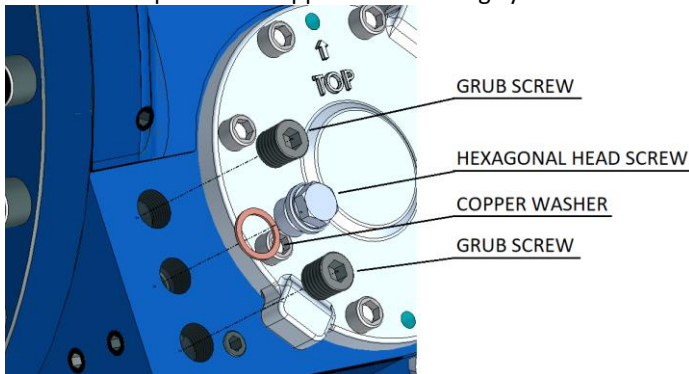

Figure 7B: standard supply

The arrangement for the interception of the lubricant circuit shall be planned at the purchase order.



## 7.4 OPTIONAL SUPPLY

### 7.4.1 Arrangement for the additional oil cooling or for the oil flow switch

The arrangement for the additional oil cooling or for the oil flow rate switch is composed by the nipples and the long cylindric head screw.

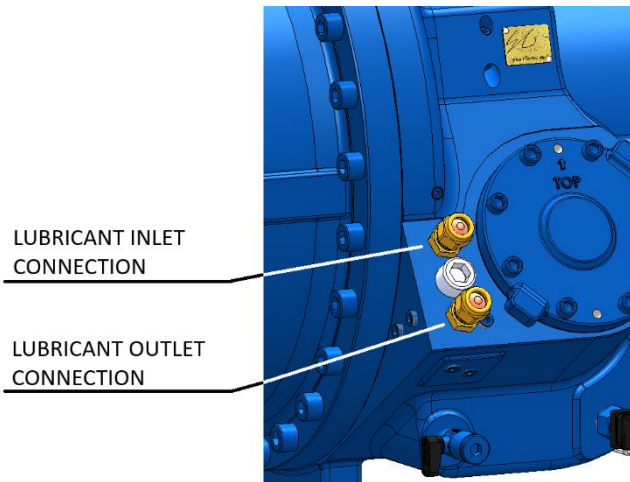



Figure 7C: optional arrangement

The safety caps shall be removed and kept in order to install the additional oil cooling or the oil flow switch.

	<p><b>Note</b></p> <p>The start-up of compressor shall be carried out after the right installation of the additional oil cooling or the oil flow rate switch and after the opening of shut-off valves only.</p>
--	---

### 7.4.2 Oil level monitor device

The standard supply of the K2 series compressors does not include the oil level monitor device. The oil level monitor kit is composed by:

1. aluminium gasket
2. mechanical adaptor sight
3. electronical device

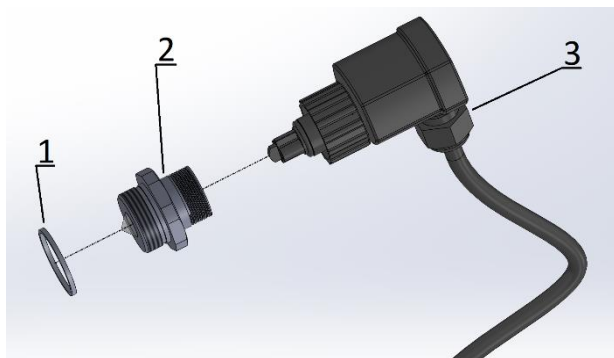

Figure 7D: Oil level monitor kit

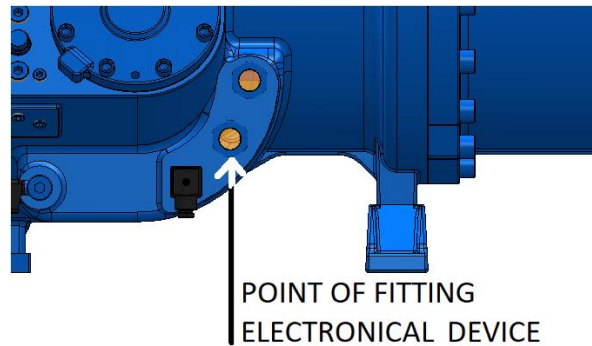

Figure 7E: Point of fitting for oil level device

In case of supply of the optical device for the oil level control, the aluminium washer (1) and the sight glass for the mechanical adaptation (2) are assembled instead of the standard sight glass; the electronical device (3) is supplied in the electrical box and it shall be assembled on the sight glass (2). The kit shall be required at the purchase order of the compressor.



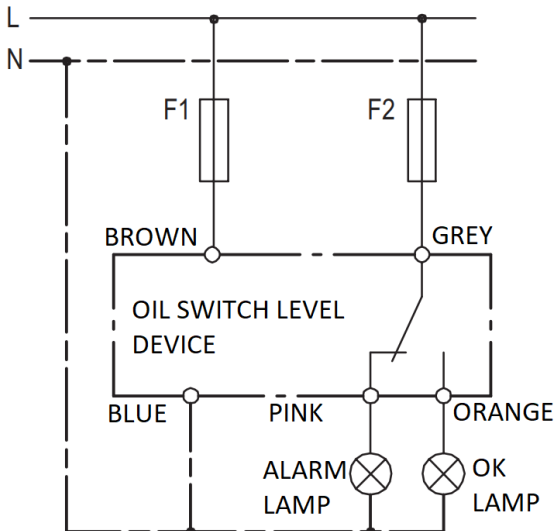

Figure 7F: wiring of oil level monitor kit



**Note**

In case of supply of the kit after the first compressor start-up, the assembly of the oil level monitor kit shall be carried out by qualified personnel.



**Important note**

Before the assembly of the kit, it is mandatory:

- disable the compressor
- wait for the complete compressor cooling down
- evacuate the refrigerant from the compressor
- recover the lubricant using the proper shut-off valve
- avoid the contact between the recovered lubricant and the ambient air during the assembly of the oil level monitor kit

**7.4.3 Oil flow switch kit**

The Oil flow switch kit may be assembled only if the compressor is equipped with the arrangement (par. 7.4.1).

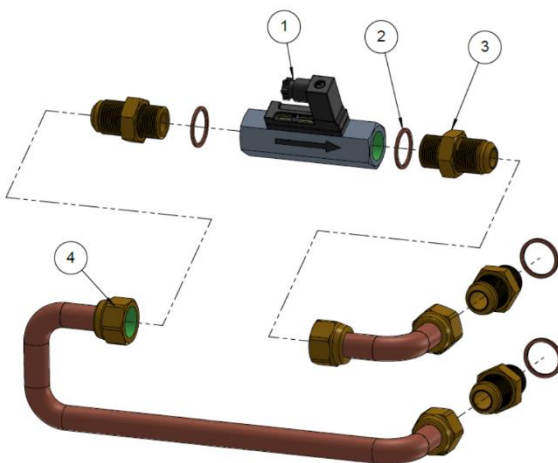

Figure 7G: example images for installation of oil switch kit



Figure 7H: indication of direction of lubricant on the oil switch

The oil flow switch kit is composed by the components listed in the following table

REFERENCE	DESCRIPTION	Q.TY
1	OIL FLOW SWITCH 10 LITER	1
2	COPPER WASHER Øi22XØ26X1.5	4
3	CONNECTION 5/8"SAE-1/2"GAS	4
4	NUT 5/8 SAE PIPE Ø16	4

#### 7.4.4 Assembly of the oil flow switch kit

- The oil flow switch can be assembled both in vertical or in horizontal position.
- Pay attention to the direction of assembling of the oil flow switch; the direction of the arrow printed on the oil flow switch shall comply with the direction of the oil flow.
- The kit does not include the supply of the shaped tubes.
- Pay attention to the electrical data printed on the oil switch: make sure not to exceed to the maximum allowed voltage.
- The oil flow switch is equipped with 2 normally open contacts; the power supply is not necessary.

	<p><b>Note</b></p> <p>The assembling of the oil flow switch shall be carried out by qualified personnel.</p>
---	--

	<p><b>Note</b></p> <ul style="list-style-type: none"> <li>• The oil flow switch kit is devoid of pipes.</li> <li>• The external diameter of the pipes shall be equal to 16mm.</li> </ul>
--	--

	<p><b>Important note</b></p> <p>In case of assembling the oil flow switch on the compressor after the first start-up, make sure to:</p> <ul style="list-style-type: none"> <li>• completely evacuate the refrigerant from the compressor;</li> <li>• wait for the complete compressor cooling.</li> </ul>
---	---

#### 7.5 LUBRICANT FLOW RATE

The lubricant flow rate in the internal circuit of the compressor depends upon difference of pressure from discharge to suction and upon dimensions of the circuit.

The lubricant flow rate can be calculated using the following formula:

$$V_{oil} \propto K_{oil} \cdot (p_{dis} - p_{suc})$$

$V_{oil}$ : oil flow rate [l/min]

$K_{oil}$ : specific coefficient of each compressor

$p_{dis}$ : discharge pressure of the compressor [bar]

$p_{suc}$ : suction pressure of the compressor [bar]

The refrigeration plant shall allow compressor to work inside the proper envelope as soon as possible so that the oil circuit performs its functions.

	<p><b>Note</b></p> <p>The compressor and the bearings can stand short working span in low conditions without the proper lubrication. Long working span without the proper lubrication can damage the compressor and compromise the working life.</p>
---	--

In case of installation of the flow switch flow rate (par. 7.4.1), it is recommended a normally open flow switch to get a closed contact during the normal working condition.

It is possible to apply a delay to signal of flow switch as follows:

- 120 s at start-up;
- 60 s during normal working conditions.

	<p><b>Note</b></p> <p>The selection of the oil flow rate switch shall consider the maximum lubricant flow rate calculated by the previous formula.</p>
---	--

	<p><b>Important note</b></p> <p>Piping dimensions shall be adequate to ensure mechanical safety and to avoid the block of the oil flow rate.</p> <p>During the installation of a flow switch, a flow rate or a flow rate meter, make sure that there is absence of pressure in the compressor and pay attention to the temperature of components and lubricant.</p>
---	---

### 7.6 OIL COOLING

During heavy working conditions, an additional oil cooling system may be necessary. Refer to chapter 08 to install cooling system. If it is necessary to apply an external heat exchanger, it will be appropriate to refer to the flow rate calculated with the previous formula for a correct dimensioning of the pipe-size diameters and of the heat exchanger itself.

### 7.7 OIL HEATING

The oil heating is mandatory in the following cases:

- long periods during which the refrigeration plant is stopped;
- low temperature of the compressor during short blocking periods of the refrigeration plant;
- in case of excessive refrigerant charge diluted in the oil charge.

The oil heating is possible thanks to an heating resistance placed below the oil filter. It is suggested to energize the electrical resistance at least 24 h before the compressor start-up.

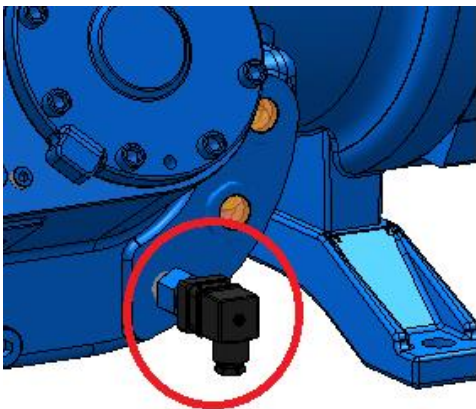



Figure 71: heating electrical resistance

	<p><b>Important note</b></p> <p>Pay attention to the electrical features of the heating resistance; the proper supply voltage is printed on the edge of the resistance.</p>
---	---

In case of assembly of the electrical resistance to the compressor, apply the proper torque and use an appropriate spanner on the metallic edge of the resistance.

The electrical connector is DIN 43650 type: do not turn the electrical cable upwards to avoid water to penetrate in connector through the cable.

### 7.8 OIL FILTER

The oil filter makes sure the lubricating circuit cleanliness and the right oil flow rate in the compressor. The excessive obstruction of the filter reduces the oil flow rate in the compressor. The obstruction of the filter can be estimated by checking the oil filter pressure downstream. Refer to the following data to estimate the obstruction of the oil filter.

WORKING CONDITION			OPTIMAL OIL FILTER CONDITION		
Pressure difference discharge-suction [ $\Delta$ HP-LP]	bar	<6	Pressure difference discharge-oil [ $\Delta$ HP-OP]	bar	<1,5
Pressure difference discharge-suction [ $\Delta$ HP-LP]	bar	>6	Pressure difference discharge-oil [ $\Delta$ HP-OP]	bar	<3

!

**Note**  
The pressure differences shall be measured at the compressor full load.

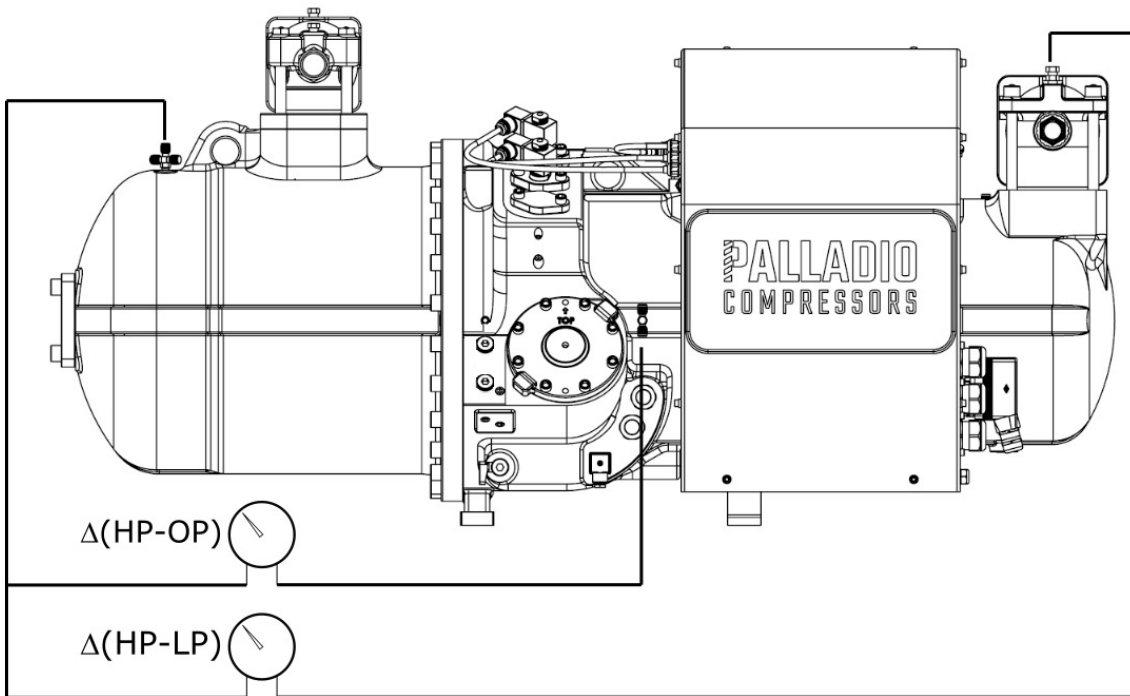

Figure 7L: pressure measurement points for high pressure (HP), oil circuit (OP) and low pressure (LP)

# *Palladio Compressors - K1 Series*

## *8. Additional cooling*

- 8.1. ADMITTED DISCHARGE TEMPERATURE OF THE COMPRESSOR
- 8.2. CALCULATION ADDITIONAL COOLING CAPACITY
- 8.3. LIQUID INJECTION
- 8.4. OIL COOLING BY HEAT EXCHANGER

### 8.1 ADMITTED DISCHARGE TEMPERATURE OF THE COMPRESSOR

The main factors determining discharge temperature are:

- absorbed electrical power which depends on:
  - working conditions (evaporating and condensing pressure);
  - operating compression ratio of the compressor;
  - cooling capacity;
- superheating of the refrigerant at suction;
- properties of refrigerant and lubricant.

The excessive discharge temperature may cause:

- carbonization and permanent alteration of the oil with reduction of its useful life;
- reduction of kinematic viscosity, consequent loss of lubrication capacity and decrease in the volumetric efficiency of the compressor.

The excessive cooling of oil may cause:

- high pressure drop in oleodynamic circuit;
- excessive dilution of the oil by the refrigerant, which has the following consequences:
  - the alteration of the lubricant flow inside the compressor and reduction of lubricating properties;
  - by-pass of suction refrigerant fluid (through the oil hydraulic circuit) and reduction of the cooling effect.

The maximum admitted discharge temperature is equal to 110 °C, but when the compressor is stopped, the minimum admitted temperature of oil is equal to 40 °C to let the start up of the compressor (chapter 7: "Lubrication").

### 8.2 CALCULATION ADDITIONAL COOLING CAPACITY

The additional cooling capacity shall be properly calculated in order to keep the discharge temperature equal or lower than 110 °C. Use suitable calculation methods and softwares.

	<p><b>Note</b></p> <p>In order to calculate the additional cooling capacity, it is recommended applying the most critical working conditions of the plant (minimum evaporation temperature, maximum condensing temperature, maximum superheating).</p>
---	--

Therefore, depending on the value of the required additional cooling capacity, two different methods are distinguished to limit the discharge temperature:

- cooling by injection of refrigerant liquid mass flow-rate in rotors;
- cooling by external oil circuit using a heat exchanger (type air/oil or water/oil or refrigerant/oil).

### 8.3 LIQUID INJECTION

This method is the injection of refrigerant fluid on rotors (saturated liquid) at intermediate pressure. The liquid refrigerant shall be tapped downstream the condenser of refrigeration plant.

	<p><b>Note</b></p> <p>If the additional required cooling capacity overcomes 10% of cooling capacity of the compressor, the liquid injection requires an excessive mass flow-rate which may cause:</p> <ol style="list-style-type: none"> <li>1. dilution of oil;</li> <li>2. decreasing of lubricating properties of oil;</li> <li>3. excessive increasing of absorbed power supply;</li> <li>4. a decrease of the compressor cooling capacity.</li> </ol>
---	--

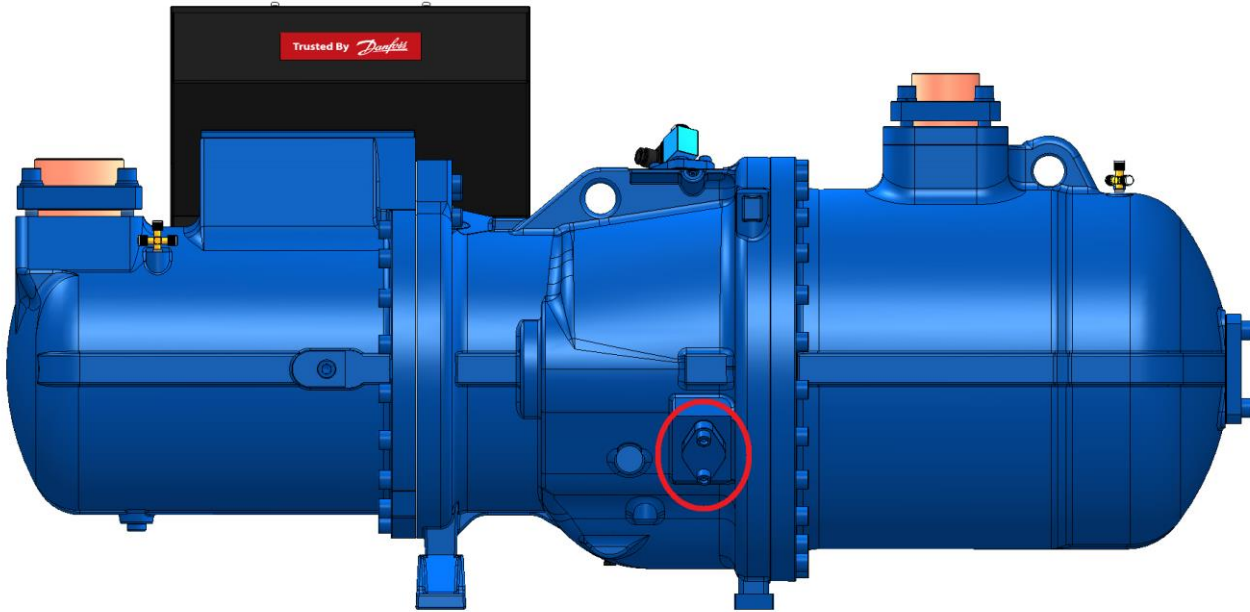

Figure 8A: Injection of refrigerant fluid (saturated liquid)

The liquid injection requires the installation of a component for the expansion; the component can be:

- expansion thermostatic valve;
- calibrated nozzle;
- capillary tube.



**Important note**

In order to select the right thermostatic expansion valve, contact the supplier of the valves.

The sensing probe or the thermal switch of the cooling system shall be placed on the discharge tube at 10 - 20 cm from the discharge shut-off valve; it shall be insulated in order not to be influenced by the external ambient temperature. Ensure the adequate mechanical thermal contact of sensor to the discharge tube.

Make sure to get liquid refrigerant at saturated or subcooling conditions.



**Note**

- Ensure the absence of dangerous vibrations on the injection tube.
- The injection tube shall be provided with a shut-off valve to close injection circuit during the stop of the plant or the stop of injection circuit.
- The injection tube shall be provided with a mechanical filter.
- The injection tube shall be provided with a siphon at least 25 cm upwards before entering the compressor.

The sensing probe or the thermal switch shall start the liquid injection when the discharge temperature overcomes 110°C, whereas it stops the liquid injection when the discharge temperature decreases under 100 – 105°C.

The compressor shall be equipped with injection connection; this optional accessory is available on request.

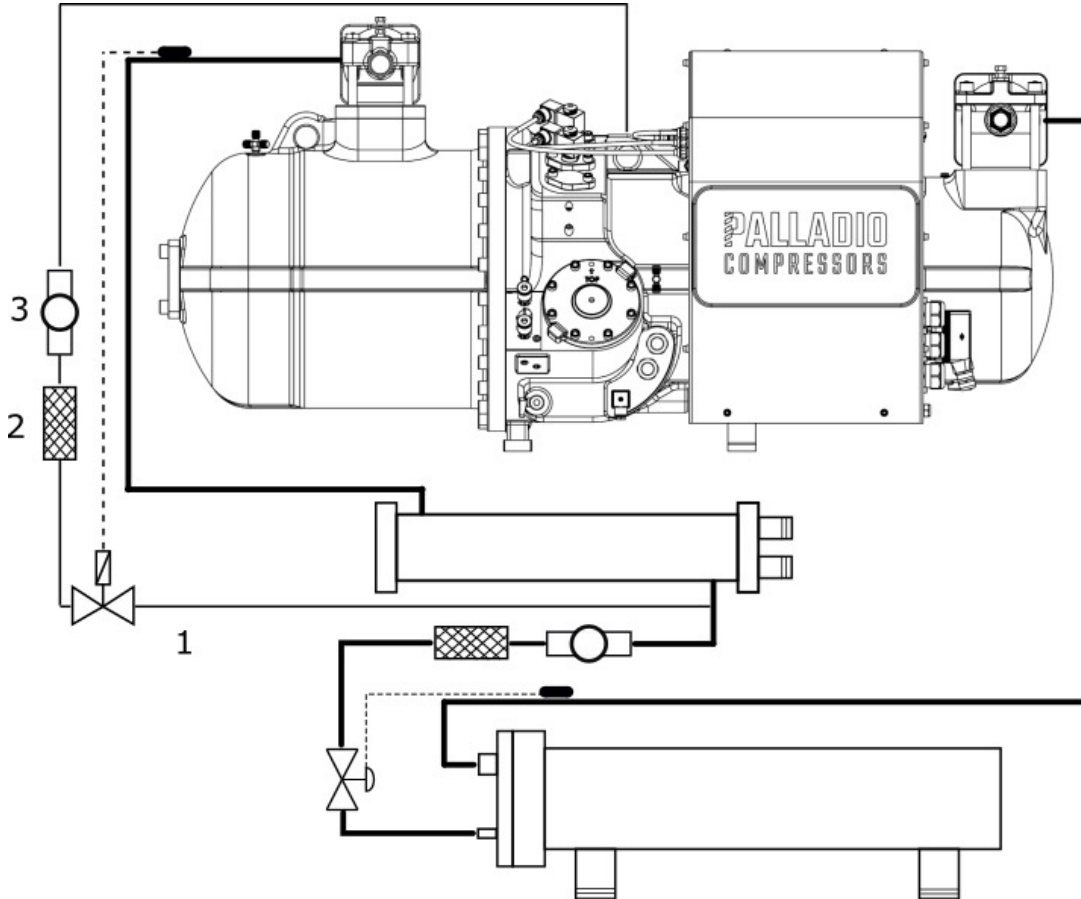



Figure 8B: example of circuit provided by liquid injection; 1) valve to open circuit; 2) filter; 3) sight glass.



## 8.4 OIL COOLING WITH HEAT EXCHANGER

### 8.4.1 Arrangement

The additional oil cooling is possible only if the compressor is provided with the proper arrangement (par. 7.4.1)

	<p><b>Note</b></p> <p>The standard delivery of the K1 series compressors is not equipped with connections for the additional oil cooling circuit (standard delivery supplied on par. 7.3).</p>
---	--

### 8.4.2 Commissioning of the oil cooling

The method to decrease discharge temperature of the compressor is the oil cooling by an external circuit. Refer to chapter 4 of the present manual about the application limits of this cooling method.

In order to connect the compressor to the external circuit, it is necessary to use the 2 brass connections placed at the oil filter side:

- lower brass connection for the outlet flow from the compressor;
- higher brass connection for the inlet flow to the compressor.

	<p><b>Note</b></p> <p>Refer to the formula about oil flow rate described in chapter 7 “Lubrication” to properly size additional heat exchanger.</p> <p>For proper sizing of the heat exchanger apply appropriate calculation methods or consult the heat exchanger supplier.</p>
---	--

	<p><b>Note</b></p> <p>Increase the oil charge with an amount equal to the internal volume of the external oil cooling circuit.</p>
--	--

	<p><b>Important note</b></p> <p>Check pressure drop if the external oil cooling circuit is lower than 0,5 bar during functioning to allow a right oil mass flow-rate at the lubrication of the compressor.</p> <p>Place the cooling heat exchanger near the compressor and use the lowest possible quantity of elbows for the tubelines of the external circuit.</p>
---	--

### 8.4.3 Cooling by air

The cooling plant composed by an air heat exchanger equipped with fans shall be activated by the probe placed on the discharge tube of the compressor whose set point is 110°C; the control can be at ON-OFF method or at a variable speed.

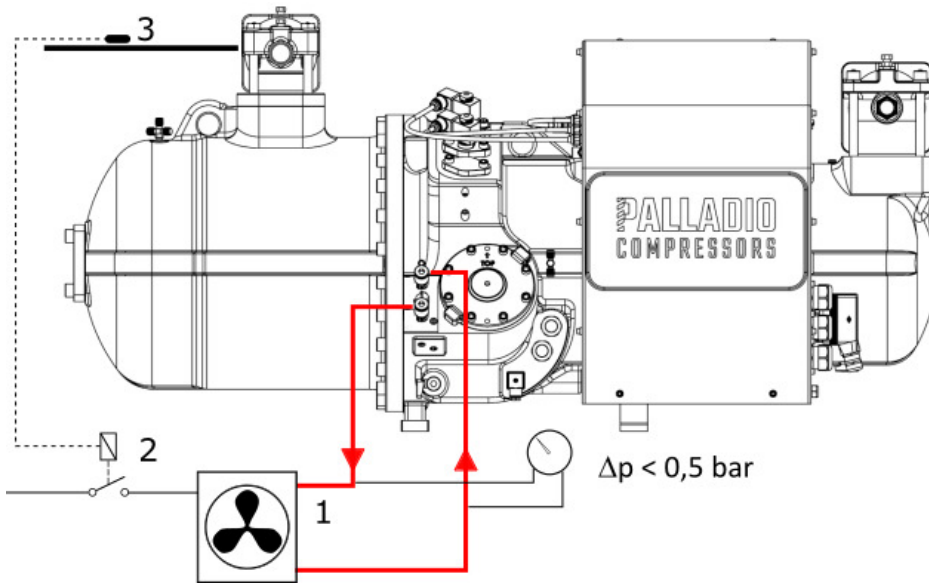

Figure 8C: cooling example; air heat exchanger (1) on-off start up (2) thermal switch on discharge tube (3) of the compressor

### 8.4.4 Cooling by water

The water/oil heat exchanger can use the condenser water or cooled water. The water supply can be modulated by a 3-way valve provided with a probe placed on the discharge tube of the compressor (set-point at 110°C).

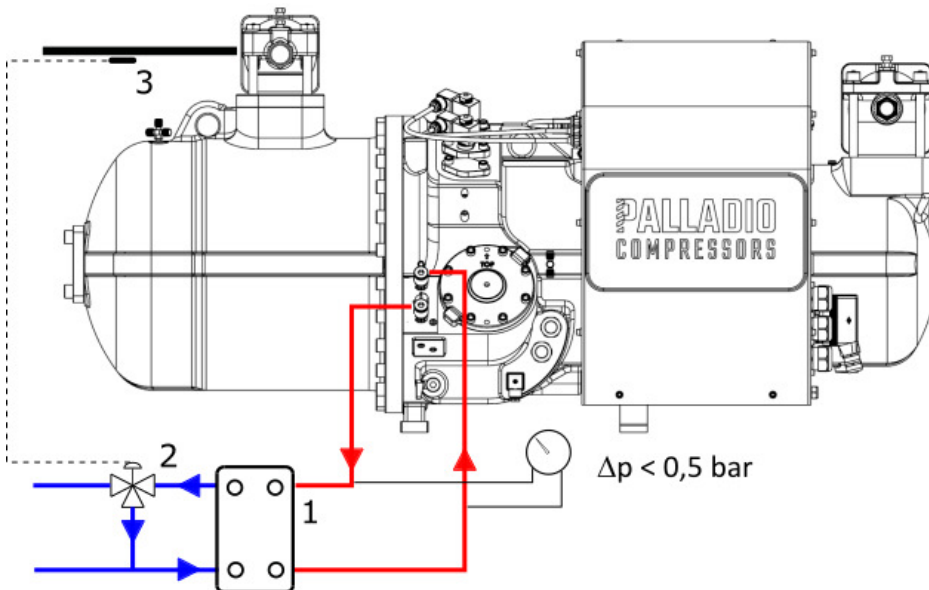

Figure 8D: cooling example 1) water heat exchanger; 2) modulating 3-way valve; 3) thermal switch on discharge tube of the compressor

### 8.4.5 Cooling by refrigerant

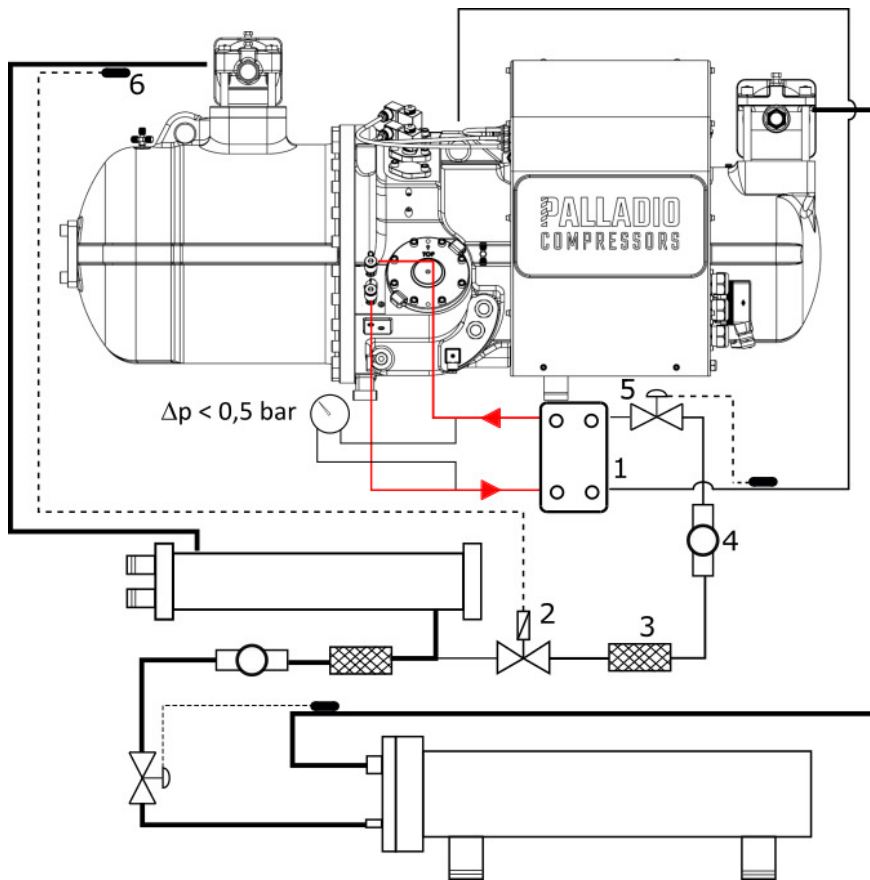

Figure 8E: example oil cooling by refrigerant; 1) a refrigerant/oil heat exchanger; 2) a valve to open circuit; 6) switch placed on discharge tube of the compressor; 3) a dryer filter on liquid tube; 4) a sight glass; 5) an expansion valve to ensure the correct superheating of the refrigerant returning to the the compressor.

The lubricant can be cooled by refrigerant tapped from the main liquid tube placed downstream the condenser. Circuit shall be opened by a check valve controlled by the compressor discharge temperature in order to avoid a by-pass from the main circuit. A thermostatic expansion valve can regulate the right refrigerant mass flow-rate to the compressor.



**Important note**

The selected heat exchanger shall be able to withstand the high difference of temperature between 2 fluids.

# *Palladio Compressors - K1 Series*

## *9. Regular Maintenance*

- 9.1. LUBRICATION
- 9.2. BEARINGS
- 9.3. PERIODIC MAINTENANCE TABLE

## 9.1 LUBRICATION

### 9.1.1 Lubricant

After the installation and the first start-up it is not necessary lubricant replacement.

	<p><b>Note</b></p> <p>Check periodically the oil acidity in order to avoid damages to the motor and to the compressor; if it is necessary, clean the circuit by placing an acid retention filter in the suction pipe.</p>
---	---

The lubricant may be collected through the low shut-off valve (chapter 7: “Lubrication”). Moreover, the lubricant can be charged in the compressor through the same shut-off valve by the vacuum in the compressor.





Figura 9A: shut-off valve for lubricant outlet and inlet

	<p><b>Important note</b></p> <p>The shut-off for lubricant inlet and outlet is placed in the zone of the compressor at high temperature and at high pressure. Do not open the shut-off valve during the compressor activity.</p>
---	--

### 9.1.2 Oil filter

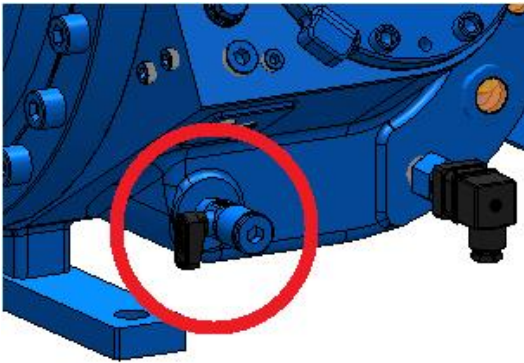
The oil circuit pressure (OP) shall be checked periodically. If it is necessary to replace the oil filter, perform the extraction of the support as follows:

1. Unscrew the screws of oil filter support flange;
2. Screw 2 M10 screws in the proper holes.

	<p><b>Important note</b></p> <p>Make sure that there is no pressure in the compressor before extracting the oil filter support. The oil filter support shall not be removed during the compressor activity.</p>
---	---

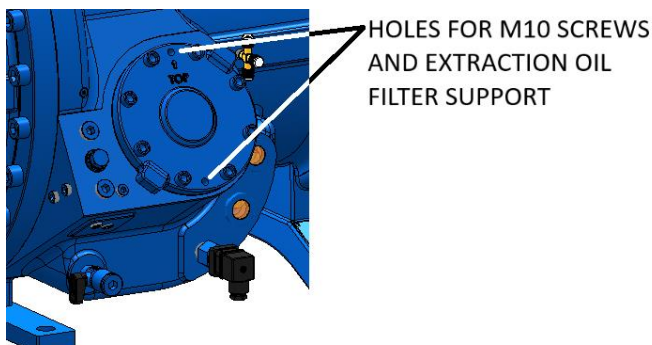



Figure 9B: holes for the extraction of the oil filter support

### 9.2 BEARINGS

The bearings are designed to 40000 working hours in condition of a regular lubrication, cleaned oil filter, expected oil pressure (chapter 6: "Lubrication") and expected envelope (chapter 4: "Envelope"). Any alteration of the working conditions and the excessive variability of the load may reduce the effective life time of the bearings.

	<p><b>Note</b></p> <p>The substitution of the bearings can be carried out by qualified personnel in an equipped factory only.</p>
---	---

### 9.3 PERIODIC MAINTENANCE TABLE

The following table summarizes the controls and the periodic activities of the regular maintenance:

- S: substitution
- C: control

COMPONENTS	ACTIVITY					
	Period (h)					
	50-100	1000	10000	20000	30000	40000
Oil filter	C/S					S
Oil	C	C	C	C	C	S
Suction filter		C	C		C	C
Solenoid valves		C	C	C	C	C
Bearings						S
Check valve		C	C	C	C	C
Power voltage	C	C	C	C	C	C
Motor contactor		C	C	C	C	C

# *Palladio Compressors - K1 Series*

## *10. Weights And Overall Dimensions*

- 10.1. OVERALL K1\_\_410/560
- 10.2. OVERALL K1\_\_640/810
- 10.3. WEIGHTS AND PACKAGINGS

**10.1 OVERALL K1\_410/560**

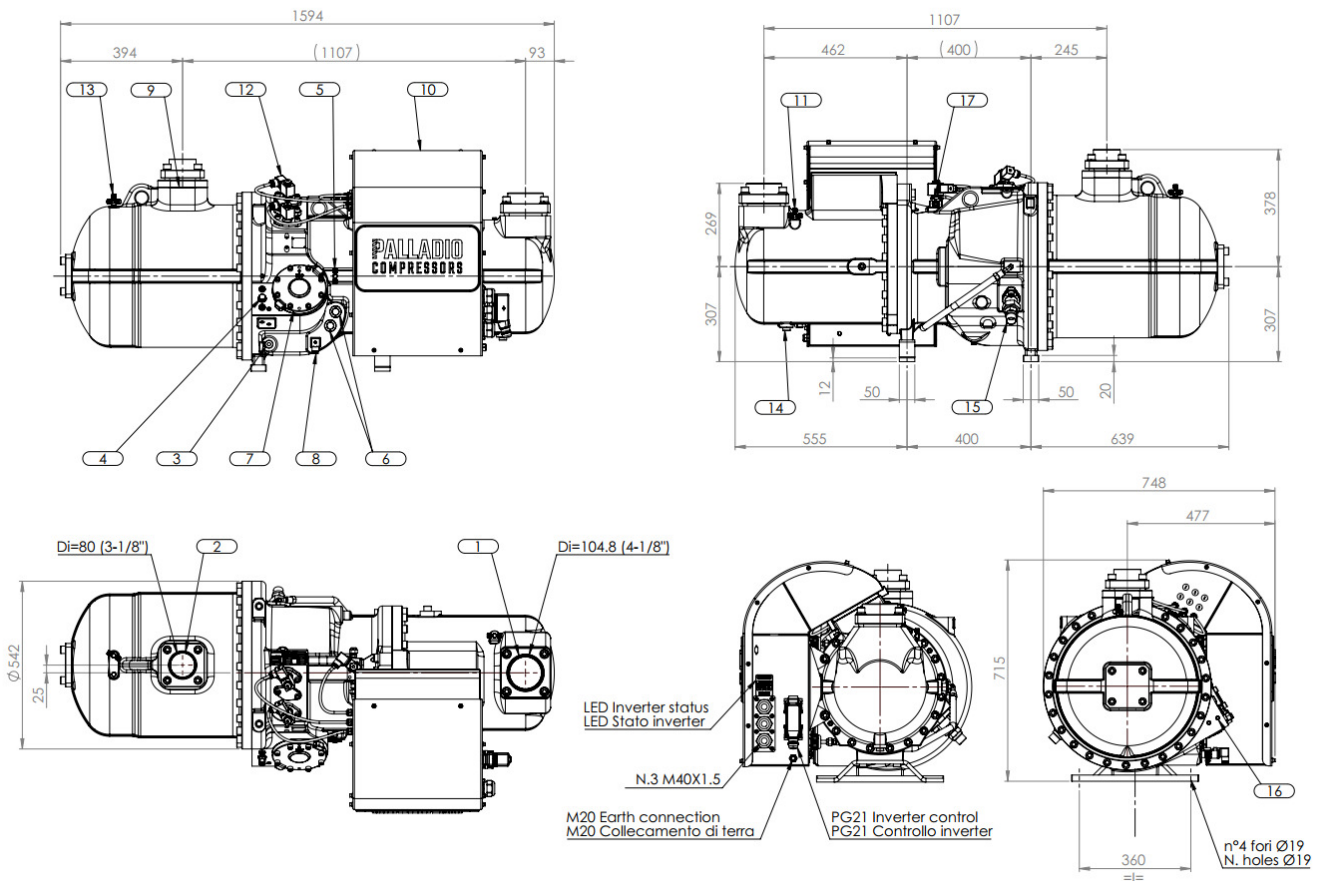

**LEGENDA**

- |     |   |
|-----|---|
| 1)  | Suction line                                  |
| 2)  | Discharge line                                |
| 3)  | Oil charge/drain valve 3/8" SAE Flare         |
| 4)  | Oil cooling connections (optional) 1/2" Flare |
| 5)  | Oil pressure connections 1/4" Flare           |
| 6)  | Oil sight glass                               |
| 7)  | Oil filter                                    |
| 8)  | Crankcase heater                              |
| 9)  | Check valve                                   |
| 10) | Integrated inverter electrical box            |
| 11) | Low pressure 1/4" SAE Flare                   |
| 12) | Automatic VI control solenoid valves          |
| 13) | High pressure 1/4" SAE Flare                  |
| 14) | Oil drain motor side                          |
| 15) | Liquid injection/Eco connection (optional)    |
| 16) | Discharge temperature sensor (1/8" NPT)       |
| 17) | Inverter cooling circuit 5/8" SAE Flare       |

Figure 10A – overall compressors K1\_410/560



**10.2 OVERALL K1\_640/810**

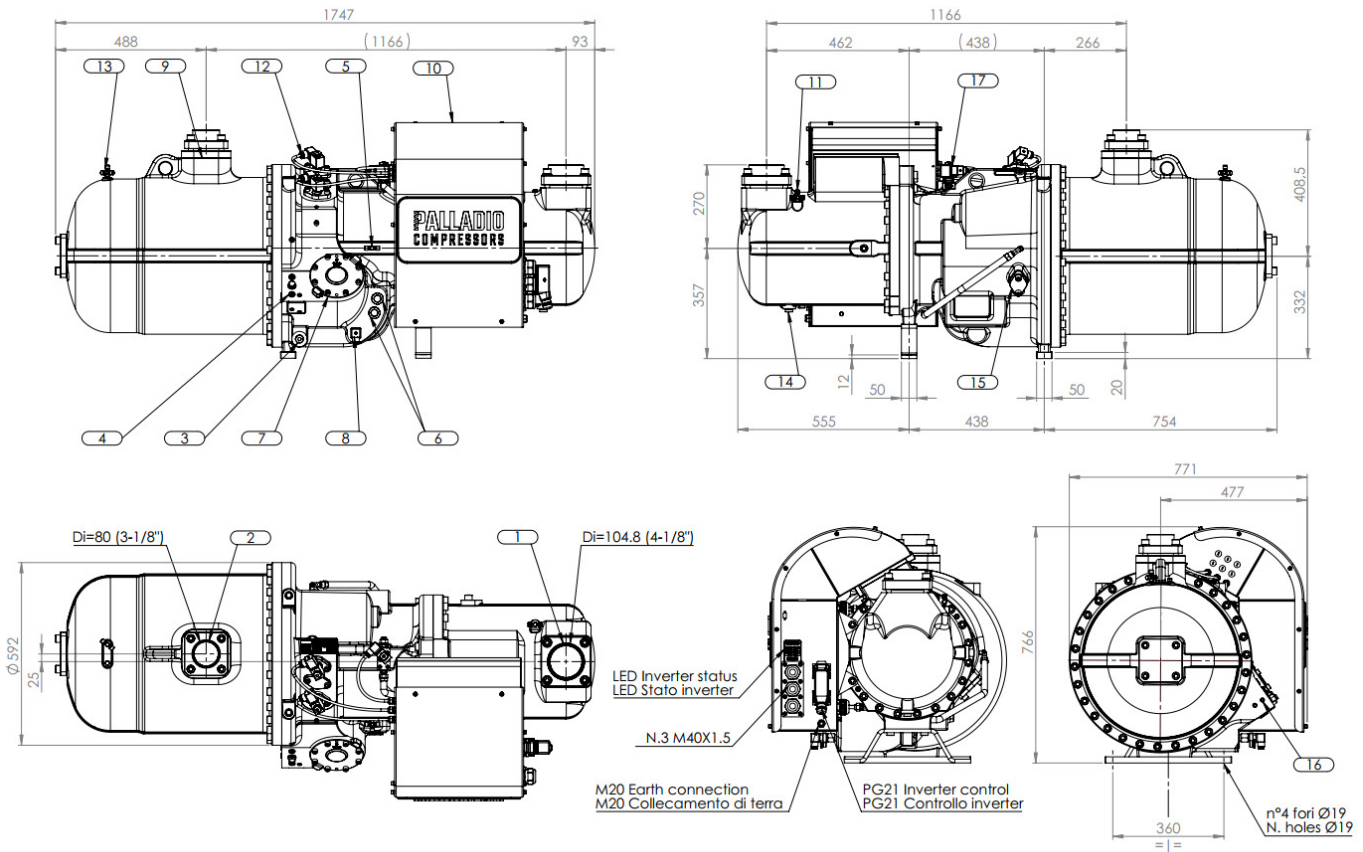

LEGENDA	
1)	Suction line
2)	Discharge line
3)	Oil charge/drain valve 3/8" SAE Flare
4)	Oil cooling connections (optional) 1/2" Flare
5)	Oil pressure connections 1/4" Flare
6)	Oil sight glass
7)	Oil filter
8)	Crankcase heater
9)	Check valve
10)	Integrated inverter electrical box
11)	Low pressure 1/4" SAE Flare
12)	Automatic VI control solenoid valves
13)	High pressure 1/4" SAE Flare
14)	Oil drain motor side
15)	Liquid injection/Eco connection (optional)
16)	Discharge temperature sensor (1/8" NPT)
17)	Inverter cooling circuit 5/8" SAE Flare

Figure 10B – overall compressors K1\_640/810

### 10.3 WEIGHTS AND PACKAGING

MODELS	COMPRESSOR WEIGHT* [kg]	PACKAGING WEIGHT [kg]	TOTAL WEIGHT [kg]	PACKAGING DIMENSIONS		
				W [mm]	H [mm]	L [mm]
K1_410	828	85	913	830	1063	1860
K1_480	840	85	925	830	1063	1860
K1_560	858	85	943	830	1063	1860
K1_640	1064	85	1149	830	1063	1860
K1_720	1064	85	1149	830	1063	1860
K1_810	1064	85	1149	830	1063	1860

\* The weight is to be considered for compressor without shut-off valves

