

MDC90 MDA90 MDK90 MD90 Diode Modules

Features:

- n Isolated mounting base 2500V~
- n Pressure contact technology with Increased power cycling capability
- n Space and weight savings

Typical Applications

- n AC/DC Motor drives
- n Various rectifiers
- n DC supply for PWM inverter

$I_{F(AV)}$	90A
V_{RRM}	600~1800V
I_{FSM}	$2.3A \times 10^3$
I^2t	$26.9A^2 \cdot S \cdot 10^3$

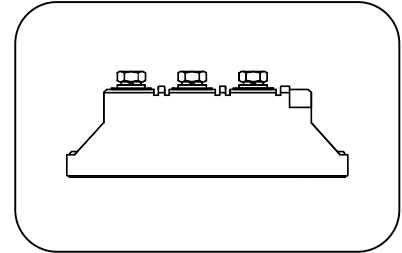

SYMBOL	CHARACTERISTIC	TEST CONDITIONS	$T_j(^{\circ}C)$	VALUE			UNIT
				Min	Type	Max	
$I_{F(AV)}$	Mean forward current	180° half sine wave 50Hz Single side cooled, $T_c=100^{\circ}C$	150			90	A
$I_{F(RMS)}$	RMS forward current		150			141	A
V_{RRM}	Repetitive peak reverse voltage	V_{RRM} tp=10ms $V_{RSM} = V_{RRM} + 200V$	150	600		1800	V
I_{RRM}	Repetitive peak current	at V_{RRM}	150			8	mA
I_{FSM}	Surge forward current	10ms half sine wave	150			2.30	KA
I^2t	I^2T for fusing coordination	$V_R=0.6V_{RRM}$					26.9
V_{FO}	Threshold voltage		150			0.80	V
r_F	Forward slop resistance						1.70
V_{FM}	Peak forward voltage	$I_{FM}=270A$	25			1.33	V
$R_{th(j-c)}$	Thermal resistance Junction to case	At 180° sine Single side cooled				0.470	$^{\circ}C/W$
$R_{th(c-h)}$	Thermal resistance case to heat sink	At 180° sine Single side cooled				0.2	$^{\circ}C/W$
V_{iso}	Isolation voltage	50Hz, R.M.S, t=1min, $I_{iso}: 1mA(max)$		2500			V
F_m	Terminal connection torque (M5)				4		N·m
	Mounting torque (M6)				6		N·m
T_{stg}	Stored temperature			-40		125	$^{\circ}C$
W_t	Weight				115		g
Outline	215F3						

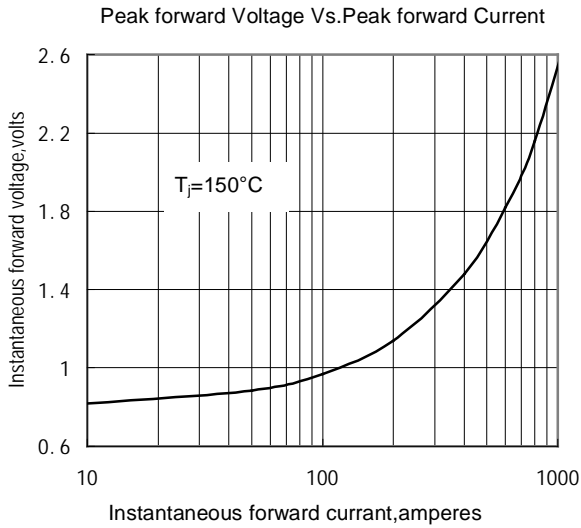

Fig.1

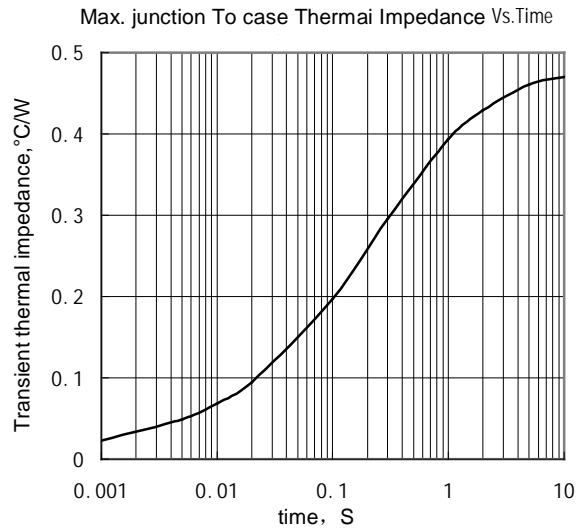

Fig.2

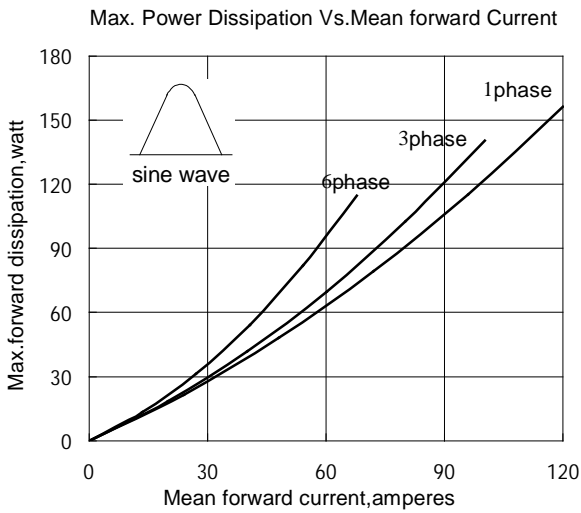

Fig.3

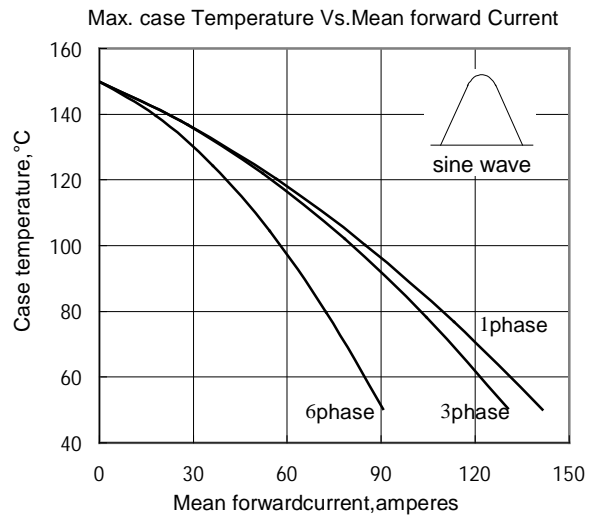

Fig.4

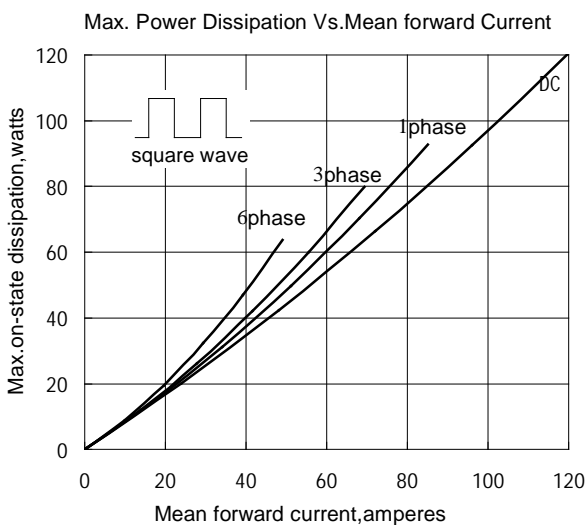

Fig.5

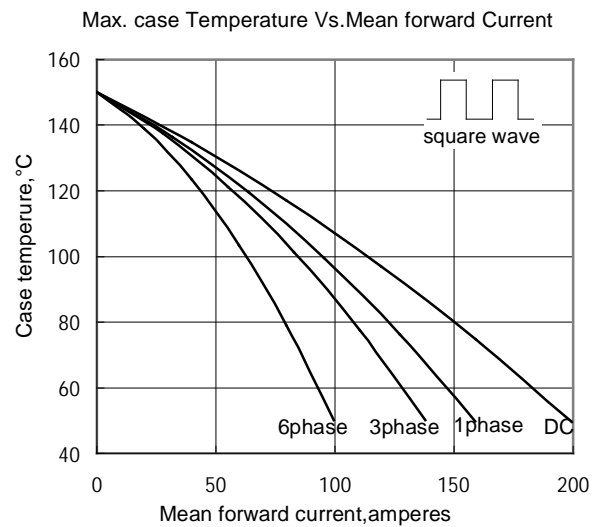

Fig.6

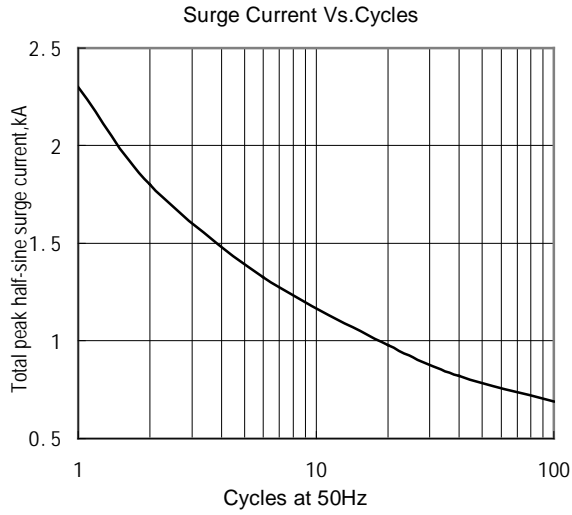

Fig.7

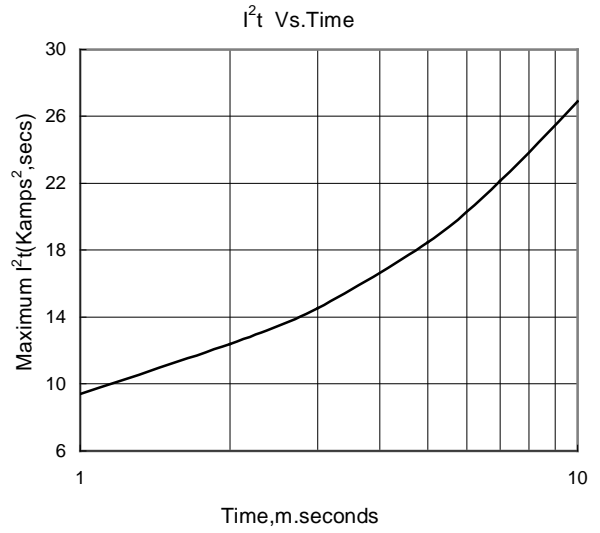
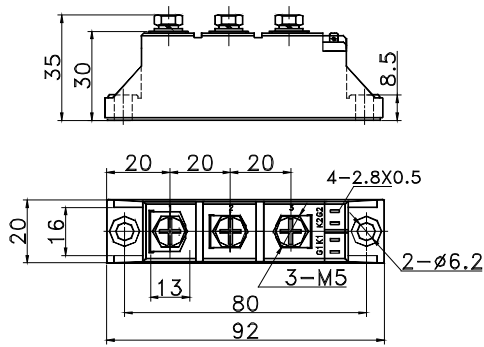

Fig.8

Outline:



215F3

