

Guide Cylinder

MGG Series

ø20, ø25, ø32, ø40, ø50, ø63, ø80, ø100

Integration of a basic cylinder and guide rods Linear Transfer Unit

Guide Cylinder MGG Series

Integration of a basic cylinder and guide rods.

- Long stroke is available.
- Equipped with a shock absorber as standard.

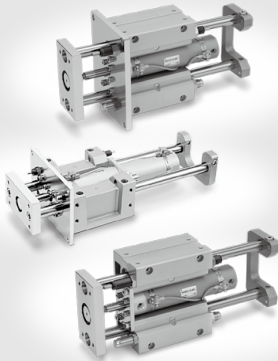

Bore size (mm)	Standard stroke (mm)						
	75	100	125	150	200	250	300
20	●	●	●	●	●	●	●
25	●	●	●	●	●	●	●
32	●	●	●	●	●	●	●
40	●	●	●	●	●	●	●
50	●	●	●	●	●	●	●
63	●	●	●	●	●	●	●
80	●	●	●	●	●	●	●
100	●	●	●	●	●	●	●

P.538

P.558
(End lock type)

Long stroke

Bore size (mm)	Long stroke (mm)													
	250	300	350	400	450	500	600	700	800	900	1000	1100	1200	1300
20	●	●												
25			●	●	●	●								
32			●	●	●	●	●							
40			●	●	●	●	●	●						
50			●	●	●	●	●	●	●					
63			●	●	●	●	●	●	●	●				
80			●	●	●	●	●	●	●	●	●			
100			●	●	●	●	●	●	●	●	●	●		

Guide Cylinder/With End Lock MGG Series

Holds the cylinder's home position even if the air supply is cut off.

- When air is discharged at the stroke end position, the lock engages to maintain the rod in that position.

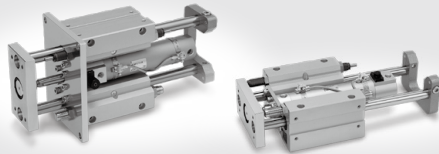

MGJ

JMGP

MGP

MGPW

MGQ

MGG

MGC

MGF

MGZ

MGT

D-□

-X□

Basic cylinder with integrated guide rods

A linear transfer unit that achieves high lateral load

Guide cylinder
 $\varnothing 20, \varnothing 25, \varnothing 32, \varnothing 40,$

Two types of guide rod bearings

Slide bearing.....Excellent wear resistance and heavy load capacity
Ball bushing....High precision and smooth operation

Can be mounted with compact auto switches.

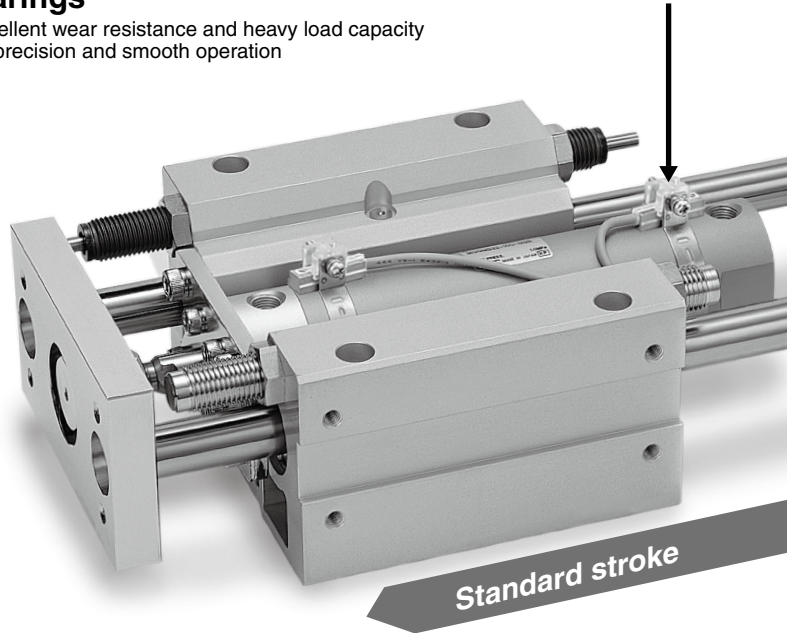

Cylinder position can be detected

All models have built-in magnets for auto switches.
 Auto switch capable throughout entire stroke range.

Application Example

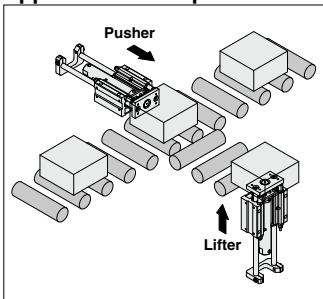

Non-rotating accuracy improved by using two guide rods

Bore size (mm)	20	25	32	40	50	63	80	100
Slide bearing	$\pm 0.07^\circ$	$\pm 0.06^\circ$	$\pm 0.06^\circ$	$\pm 0.05^\circ$	$\pm 0.04^\circ$	$\pm 0.04^\circ$	$\pm 0.04^\circ$	$\pm 0.03^\circ$
Ball bushing	$\pm 0.06^\circ$	$\pm 0.05^\circ$	$\pm 0.04^\circ$	$\pm 0.04^\circ$	$\pm 0.04^\circ$	$\pm 0.03^\circ$	$\pm 0.03^\circ$	$\pm 0.02^\circ$

When the cylinder is retracted (initial value), the non-rotating accuracy without loads or deflection of the guide rods will be below the values shown in the table.

A grease fill port is provided as standard

This allows lubrication of the bearings.

in a compact configuration
resistance and non-rotating precision

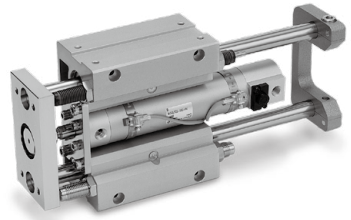

MGG Series

ø50, ø63, ø80, ø100

End lock option introduced to allow holding of cylinder position even when air supply is cut off.

When air is discharged at the stroke end position, the lock engages to maintain the rod in that position.

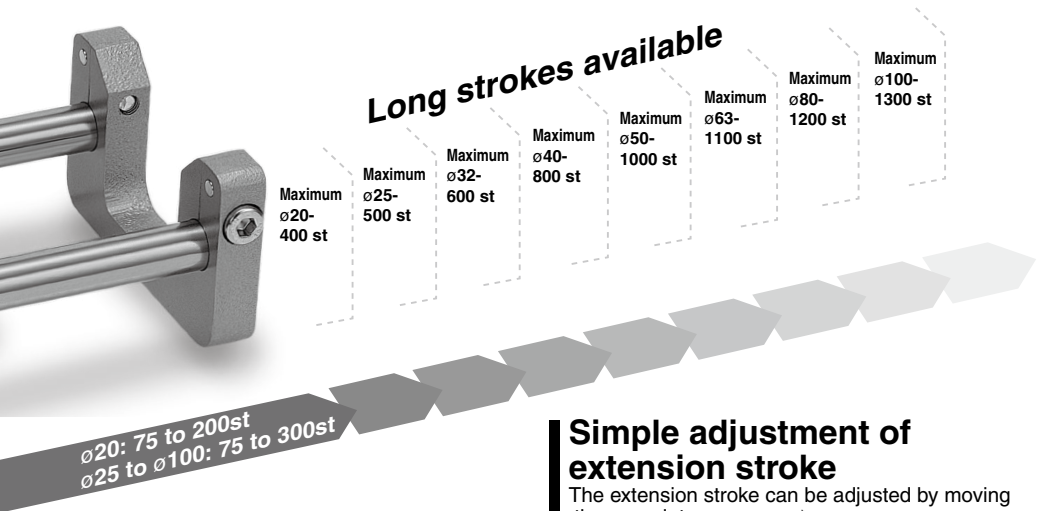

Shock absorbers and adjustment bolts are standard.

Stroke end shock absorption for high speed operation and fine stroke adjustment are possible.

Simple adjustment of extension stroke

The extension stroke can be adjusted by moving the rear plate.

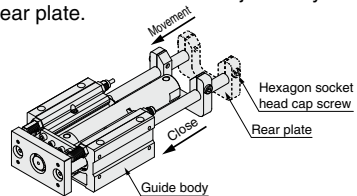

Four mounting types

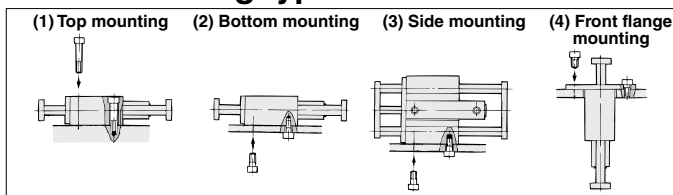

A full range of Made-to-Order specifications



MGG

JMGP

MGP

MGPW

MGQ

MGG

MGC

MGF

MGZ

MGT

D-□

-X□

Guide Cylinder MGG Series

ø20, ø25, ø32, ø40, ø50, ø63, ø80, ø100

How to Order

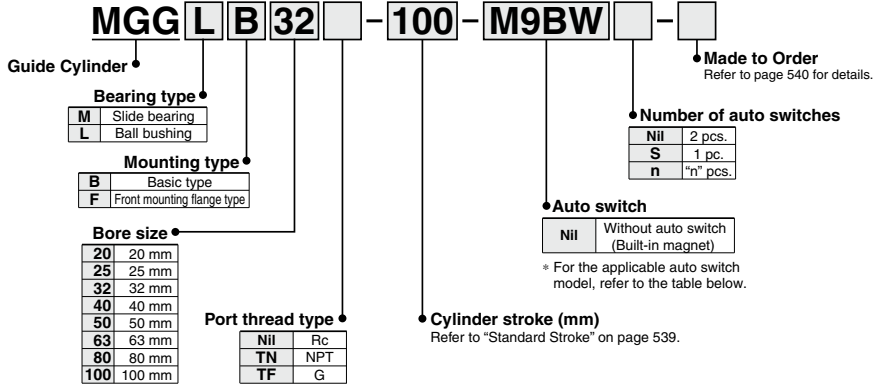

Applicable Auto Switches

Refer to pages 1119 to 1245 for further information on auto switches.

Type	Special function	Electrical entry	Indicator light	Wiring (Output)	Auto switch model		Auto switch model					Lead wire length (m)					Pre-wired connector	Applicable load	
					DC	AC	Applicable bore (mm)			0.5 (Nil)	1 (M)	3 (L)	5 (Z)	None (N)	None (N)				
							ø20 to ø63	ø80, ø100	Perpendicular							In-line			In-line
Solid state auto switch	—	Grommet	—	3-wire (NPN)	5 V, 12 V	—	M9NV	M9N	—	●	●	○	—	—	—	—	IC circuit		
				3-wire (PNP)			M9PV	M9P	—	●	●	○	—	—	—				
				—			—	—	G59	—	●	●	○	—	—	—			
				—			—	—	G5P	—	●	●	○	—	—	—			
	Diagnostic indication (2-color indicator)	Connector	Yes	—	2-wire	12 V	—	M9BV	M9B	—	●	●	●	○	—	—	—		
					—			—	—	K59	—	●	●	○	—	—		—	
	Water resistant (2-color indicator)	Grommet	—	—	3-wire (NPN)	24 V	5 V, 12 V	—	M9NWV	M9NW	—	●	●	○	—	—	IC circuit		
					3-wire (PNP)				M9PVV	M9PW	—	●	●	○	—	—		—	
					2-wire				—	—	—	G59W	—	●	●	○		—	—
					3-wire (NPN)				M9BWW	M9BW	—	●	●	○	—	—		—	
With diagnostic output (2-color indicator)	Connector	Yes	—	3-wire (PNP)	5 V, 12 V	—	—	M9BAV*1	M9BA*1	—	○	○	●	○	—	IC circuit			
				2-wire				—	—	—	○	○	●	○	—		—		
				3-wire (PNP)				—	—	—	○	○	●	○	—		—		
				2-wire				—	—	—	○	○	●	○	—		—		
				4-wire (NPN)				—	—	—	○	○	●	○	—		—		
				—				—	—	—	G5BA*1	—	●	●	○		—	—	
Reed auto switch	—	Grommet	Yes	3-wire (NPN equivalent)	5 V	—	—	A96V	A96	—	●	—	—	—	—	IC circuit			
				—				A93V*2	A93	—	●	●	●	—	—		—		
				—				A90V	A90	—	●	●	●	—	—		—		
				—				—	—	—	●	●	●	—	—		—		
				—				—	—	—	●	●	●	—	—		—		
				—				—	—	—	●	●	●	—	—		—		
				—				—	—	—	●	●	●	—	—		—		
				—				—	—	—	●	●	●	—	—		—		
				—				—	—	—	●	●	●	—	—		—		
				—				—	—	—	●	●	●	—	—		—		
Diagnostic indication (2-color indicator)	Connector	No	—	2-wire	24 V	12 V	—	—	—	B54	—	●	●	—	—				
				—				—	B64	—	●	●	—	—					
				—				—	—	—	●	●	●	—		—	—		
				—				—	—	—	●	●	●	—		—	—		
—	Grommet	Yes	—	—	—	—	—	—	—	C73C	—	●	●	●	IC circuit				
				—				—	C80C	—	●	●	●	—		—	—		
										B59W									

*1 Water resistant type auto switches can be mounted on the above models, but in such case SMC cannot guarantee water resistance. A water resistant type cylinder is recommended for use in an environment which requires water resistance. Consult with SMC regarding water resistant types for ø20 and ø25.

*2 1 m type lead wire is only applicable to D-A93.

* Lead wire length symbols: 0.5 m Nil (Example) M9NW
 1 m M (Example) M9NWM
 3 m L (Example) M9NWL
 5 m Z (Example) M9NWX
 None N (Example) H7CN

* Solid state auto switches marked with "○" are produced upon receipt of order.

* Since there are other applicable auto switches than listed, refer to page 570 for details.

* For details about auto switches with pre-wired connector, refer to pages 1192 and 1193.

* D-A9□(V)/M9□(V)/M9□(V)/M9□(A)(V) auto switches are shipped together (not assembled). (Only switch mounting brackets are assembled at the time of shipment.)

Caution

When using auto switches shown inside (), stroke end detection may not be possible depending on the One-touch fitting or speed controller model. Please contact SMC in this case.

Specifications

Symbol
Rubber bumper

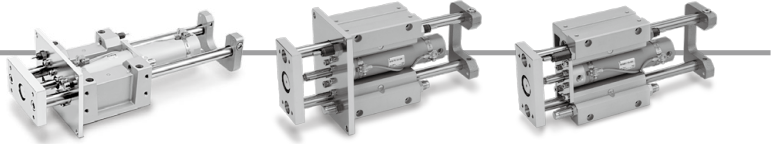

Standard Stroke

Model (Bearing type)	Bore size (mm)	Standard stroke (mm)	Long stroke (mm)
MGGM (Slide bearing) MGGL (Ball bushing)	20	75, 100, 125, 150, 200	250, 300, 350, 400
	25		350, 400, 450, 500
	32		350, 400, 450, 500, 600
	40		350, 400, 450, 500, 600, 700, 800
	50	75, 100, 125, 150, 200, 250, 300	350, 400, 450, 500, 600, 700, 800, 900, 1000
	63		350, 400, 450, 500, 600, 700, 800, 900, 1000, 1100
	80		350, 400, 450, 500, 600, 700, 800, 900, 1000, 1100, 1200
	100		350, 400, 450, 500, 600, 700, 800, 900, 1000, 1100, 1200, 1300

* Intermediate strokes and short strokes other than the above are produced upon receipt of order.

Specifications

Model	MGG□□20	MGG□□25	MGG□□32	MGG□□40	MGG□□50	MGG□□63	MGG□□80	MGG□□100	
Basic cylinder	CDG1ZN Bore size Port thread type Stroke Z Auto switch						CDG1BN Bore size Port thread type		
Bore size (mm)	20	25	32	40	50	63	80	100	
Action	Double acting								
Fluid	Air								
Proof pressure	1.5 MPa								
Maximum operating pressure	1.0 MPa								
Minimum operating pressure	0.15 MPa (Horizontal with no load)								
Ambient and fluid temperature	-10 to 60°C								
Piston speed	50 to 1000 mm/s						50 to 700 mm/s		
Cushion	Rubber bumper								
	Guide unit Built-in shock absorbers (2 pcs.)								
Stroke adjusting range (One side) [Built-in adjusting bolts (2 pcs.)]	0 to -10 mm			0 to -15 mm					
Base cylinder lubrication	Non-lube								
Stroke length tolerance	^{+1.9} mm (1000 st or less), ^{+2.3} mm (1001 st or more) _{+0.2}								
Non-rotating* accuracy	Slide bearing	±0.07°	±0.06°	±0.06°	±0.05°	±0.04°	±0.04°	±0.03°	
	Ball bushing	±0.06°	±0.05°	±0.04°	±0.04°	±0.04°	±0.03°	±0.02°	
Piping port size (Rc, NPT, G)	1/8					1/4		3/8	1/2

* When the cylinder is retracted (initial value), the non-rotating accuracy without loads or deflection of the guide rods will be below the values shown in the table above as a guideline.

Shock Absorber Specifications

Shock absorber model	RB1007	RB1412	RB2015	RB2725	
Applicable guide cylinder	MGG□□20	MGG□□25, 32	MGG□□40, 50, 63	MGG□□80, 100	
Maximum energy absorption (J)	5.88	19.6	58.8	147	
Stroke absorption (mm)	7	12	15	25	
Maximum collision speed (m/s)	5				
Max. operating frequency (cycle/min) [†]	70	45	25	10	
Ambient temperature range (°C)	-10 to 80				
Spring force (N)	Extended	4.22	6.86	8.34	8.83
	Retracted	6.86	15.98	20.5	20.01

* It denotes the values at the maximum energy absorption per one cycle. Therefore, the operating frequency can be increased according to the energy absorption.

Shock Absorbers

Type	Bore size (mm)			
	20	25, 32	40, 50, 63	80, 100
Standard (shock absorber RB series)	RB1007	RB1412	RB2015	RB2725
Shock absorber soft type RJ series type (-XB22)	RJ1007H	RJ1412H	—	—

* The shock absorber service life is different from that of the MGG cylinder.

Refer to "Specific Product Precautions" for each shock absorber for the replacement period.

* The shock absorber soft type RJ series type (-XB22) is a made to order specification. For details, refer to page 1296.

Theoretical Output

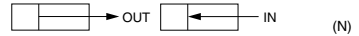

Bore size (mm)	Rod size (mm)	Operating direction	Piston area (mm ²)	Operating pressure (MPa)								
				0.2	0.3	0.4	0.5	0.6	0.7	0.8	0.9	1.0
20	8	OUT	314	62.8	94.2	126	157	188	220	251	283	314
		IN	264	52.8	79.2	106	132	158	185	211	238	264
25	10	OUT	491	98.2	147	196	246	295	344	393	442	491
		IN	412	82.4	124	165	206	247	288	330	371	412
32	12	OUT	804	161	241	322	402	482	563	643	724	804
		IN	691	138	207	276	346	415	484	553	622	691
40	16	OUT	1260	252	378	504	630	756	882	1010	1130	1260
		IN	1060	212	318	424	530	636	742	848	954	1060
50	20	OUT	1960	392	588	784	980	1180	1370	1570	1760	1960
		IN	1650	330	495	660	825	990	1160	1320	1490	1650
63	20	OUT	3120	624	936	1250	1560	1870	2180	2500	2810	3120
		IN	2800	560	840	1120	1400	1680	1960	2240	2520	2800
80	25	OUT	5030	1010	1510	2010	2520	3020	3520	4020	4530	5030
		IN	4540	908	1360	1820	2270	2720	3180	3630	4090	4540
100	30	OUT	7850	1570	2360	3140	3930	4710	5500	6280	7070	7850
		IN	7150	1430	2150	2860	3580	4290	5010	5720	6440	7150

Note) Theoretical output (N) = Pressure (MPa) x Piston area (mm²)

Weight

Bore size (mm)		20	25	32	40	50	63	80	100
Basic weight	LB Type (Ball bushing bearing, Basic type)	1.72	2.82	3.84	7.19	11.63	16.6	26.32	37.46
	LF Type (Ball bushing bearing, Front mounting flange type)	2.44	3.79	4.87	9.38	14.17	20.58	33	45.98
	MB Type (Slide bearing, Basic type)	1.71	2.79	3.36	7.17	11.36	16.22	25.61	36.36
	MF Type (Slide bearing, Front mounting flange type)	2.42	3.75	4.39	9.37	13.89	20.2	32.29	44.89
Additional weight per each 50 mm of stroke		0.14	0.17	0.25	0.4	0.61	0.82	1.11	1.48
Additional weight for long stroke		0.01	0.01	0.02	0.03	0.06	0.1	0.19	0.26
Additional weight with bracket		0.011	0.018	0.019	0.031	0.061	0.269	0.384	0.548

Calculation: (Example) **MGGLB32-500** (Ball bushing bearing) (Basic type, ø32, 500 st, With bracket)

- Standard weight 3.84 (LB type)
 - Additional weight for stroke 0.25/50 st
 - Stroke 500 st
 - Additional weight for long stroke 0.02
 - Additional weight with bracket 0.019
- 3.84 + 0.25 x 500/50 + 0.02 + 0.019 = 6.379 kg

Weight of Moving Parts

Bore size (mm)		20	25	32	40	50	63	80	100
Moving parts basic weight		0.69	1.14	1.61	3.09	5.23	8.29	13.09	18.58
Additional weight by each 50 mm of stroke		0.109	0.135	0.203	0.326	0.509	0.679	0.948	1.265

Calculating weight of moving parts (Example): **MGGLB32-500**

- Moving parts basic weight 1.61
 - Additional weight for stroke 0.203/50 st
 - Stroke 500 st
- 1.61 + 0.203 x 500/50 = 3.64 kg

Made to Order

Made to Order: Individual Specifications
(For details, refer to pages 571 to 574.)

Symbol	Specifications
-X440	With piping ports for grease
-X772	With piping ports for grease, auto switch rail mounting type

Made to Order Specifications
(For details, refer to pages 1247 to 1440.)

Symbol	Specifications
XB6	Heat resistant cylinder (150°C)
XB13	Low speed cylinder (5 to 50 mm/s)
XB22	Shock absorber soft type RJ series type
XC4	With heavy duty scraper
XC6	Made of stainless steel
XC8	Adjustable stroke cylinder/Adjustable extension type
XC9	Adjustable stroke cylinder/Adjustable retraction type
XC11	Dual stroke cylinder/Single rod type
XC13	Auto switch rail mounting
XC22	Fluororubber seals
XC35	With coil scraper
XC37	Larger throttle diameter of connecting port
XC56	With knock pin hole
XC71	Helical insert thread specifications
XC72	Not possible for built-in magnet for auto switch
XC73	Cylinder with lock (CDNG)
XC79	Machining tapped hole, drilled hole, and pin hole additionally
XC83	Cylinder with lock (MDNB)

Air-hydro

Low pressure hydraulic cylinder of 1.0 MPa or less
 When used together with a CC series air-hydro unit, constant and low speed actuation, and intermediate stopping similar to hydraulic units are possible with the use of valves and other pneumatic equipment.

MGGH Bearing type Mounting type Bore size - Stroke

↓ Air-hydro

Specifications

Bore size (mm)	20, 25, 32, 40, 50, 63	
Action	Double acting	
Fluid	Turbine oil	
Proof pressure	1.5 MPa	
Maximum operating pressure	1.0 MPa	
Minimum operating pressure	0.18 MPa (Horizontal with no load)	
Piston speed	15 to 300 mm/s	
Cushion	Basic cylinder	None
	Guide unit	Built-in shock absorbers (2 pcs.)
Ambient and fluid temperature	+5 to 60°C	
Mounting	Basic type	
	Front mounting flange type	

* For specifications other than the above, refer to page 539.
 * Auto switch can be mounted.

Dimensions (Dimensions other than the above are the same as the standard type.)

ø20 to ø50

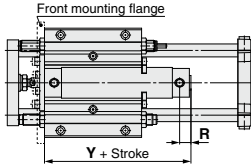

ø63

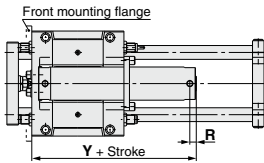

Bore size (mm)	20	25	32	40	50	63
R	14	14	14	15	16	16
Y	79	79	81	89	104	119

Series Applicable to Operating Environments that Do Not Accept Copper

- Copper (Cu) and zinc (Zn)-free.....25A series
- Copper and Fluorine-free.....20 series

* For details, refer to the SMC website.

Water Resistant

The installation of a special scraper in front of the rod seal on the base cylinder protects against the entry of liquids from the environment into the cylinder. This type can be used in environments with machine tool coolants, and with water spray such as food processing and car washing equipment.

MGGM Mounting type Bore size Port thread type R - Stroke - M9NA -XC6

↓ Slide bearing

Water resistant cylinder

R	NBR seals (Nitrile rubber)
V	FKM seals (Fluororubber)

Water resistant 2-color indicator solid state auto switch

↓ Made to Order Specifications

Specifications

Bore size (mm)	32, 40, 50, 63, 80, 100	
Action	Double acting	
Bearing type	Slide bearing	
Cushion	Rubber bumper Built-in shock absorbers	
Auto switch mounting	Band mounting	
Made to Order	-XC6	Piston rod and rod end nut made of stainless steel
	-XC6A	Stainless steel used for all iron parts
	-XC6B	Stainless steel rod end moving parts
	-XC6C	Stainless steel rods

* Specifications other than the above is the same as the standard type.
 Note 1) RBL (coolant resistant) type shock absorber is used.
 Note 2) For details, refer to Best Pneumatics No. 2-1.

Dimensions (Dimensions other than the above are the same as the standard type.)

ø32 to ø50

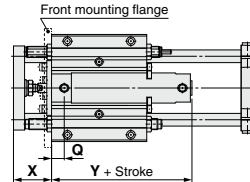

ø63 to ø100

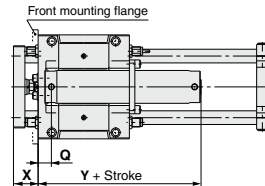

Bore size (mm)	Q			X	Y
	Rc	NPT	G		
32	16	14.5	48	77 (85)	
40	17	17	58	84 (93)	
50	19	19	69	97 (109)	
63	34	34	56	112 (124)	
80	46	43.5	68	137 (151)	
100	47	44.5	68	138 (152)	

* (): Denotes the dimensions for long stroke.

MGG

JMGP

MGP

MGPW

MGO

MGG

MGC

MGF

MGZ

MGT

D-

-X

MGG Series

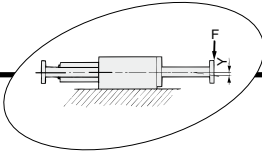

Slide Bearing Allowable End Load and Deflection

MGG □20-Stroke

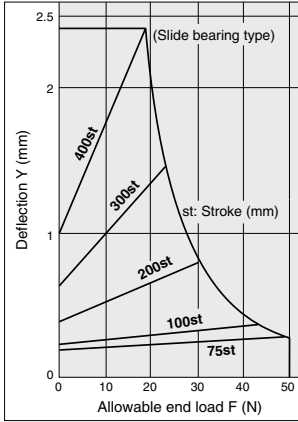

MGG □25-Stroke

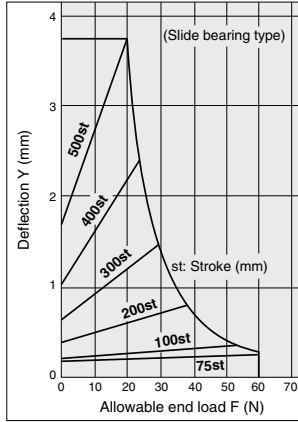

MGG □32-Stroke

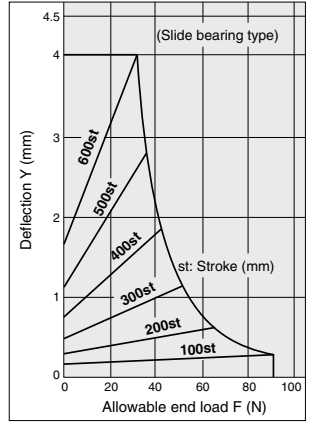

MGG □40-Stroke

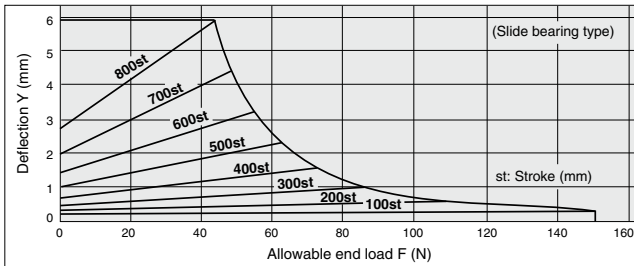

MGG □50-Stroke

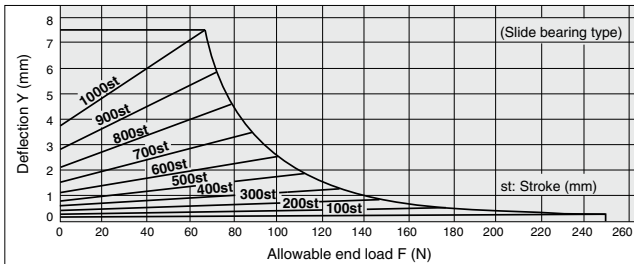

MGM □ 63-Stroke

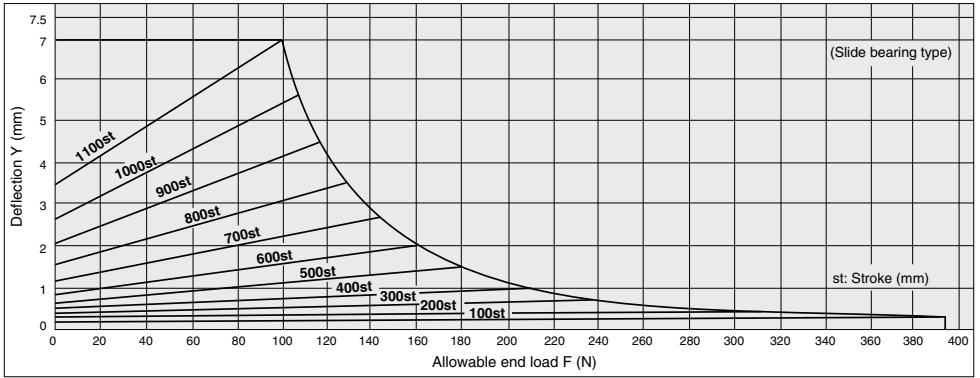

MGM □ 80-Stroke

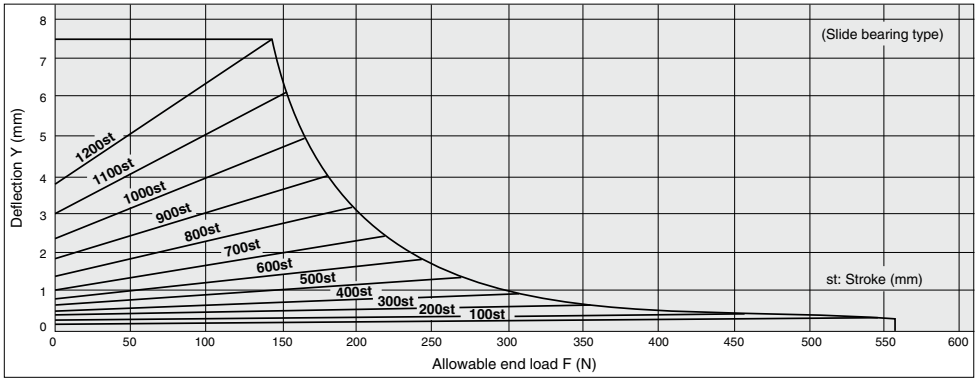

MGM □ 100-Stroke

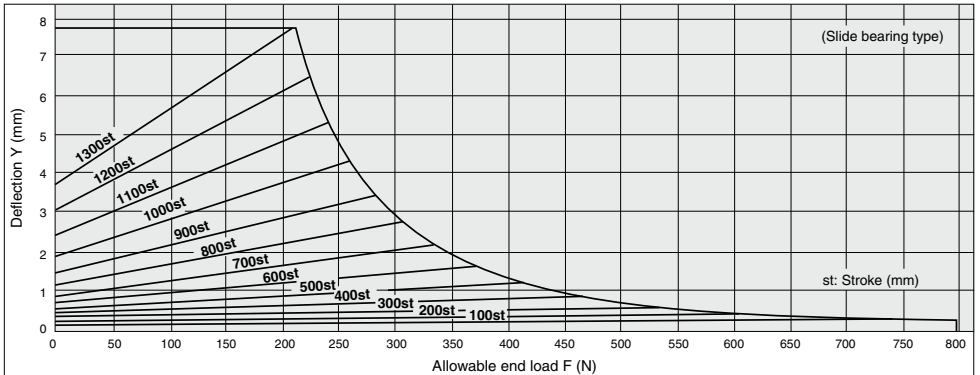

MGJ

JMGP

MGP

MGPW

MGQ

MGG

MGC

MGF

MGZ

MGT

D-□

-X□

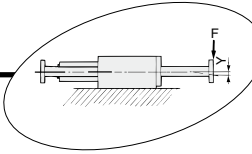

Ball Bushing Bearing Allowable End Load and Deflection

MGGL 20-Stroke

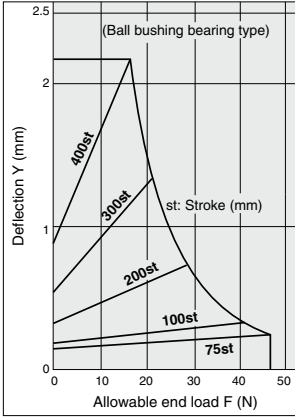

MGGL 25-Stroke

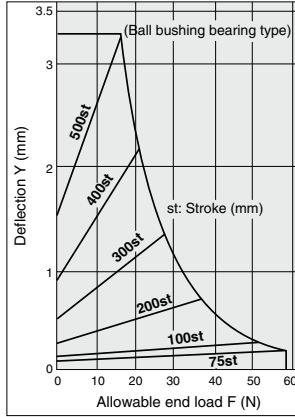

MGGL 32-Stroke

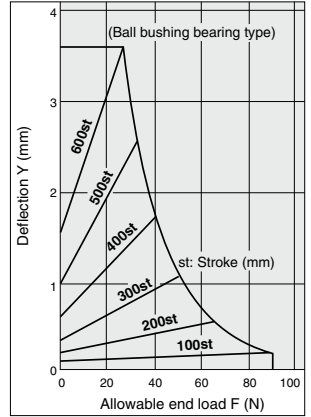

MGGL 40-Stroke

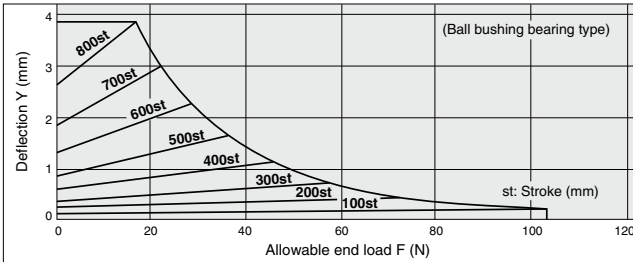

MGGL 50-Stroke

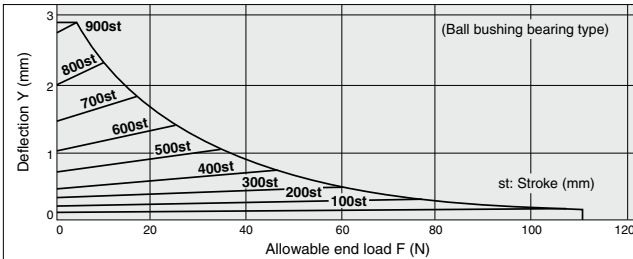

MGGL 63-Stroke

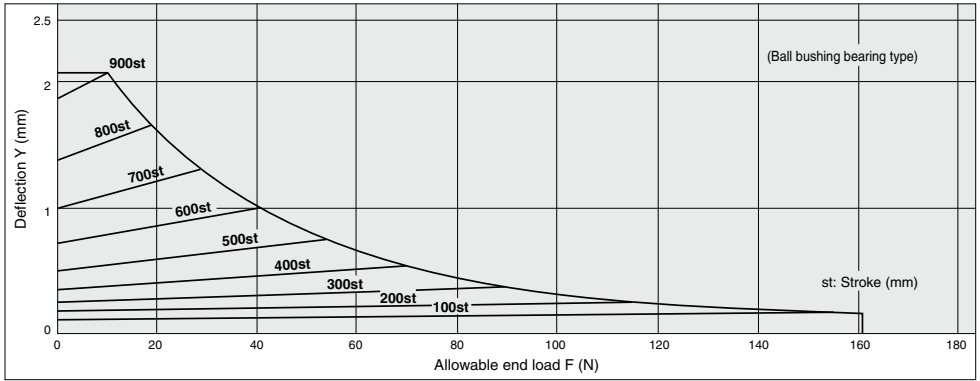

MGGL 80-Stroke

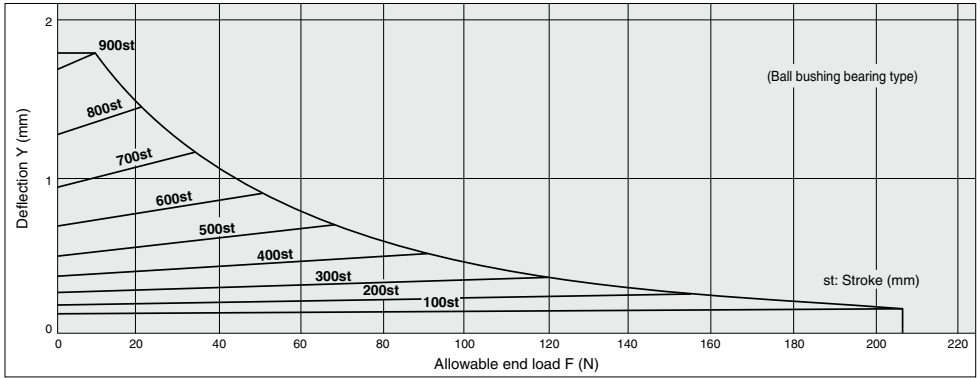

MGGL 100-Stroke

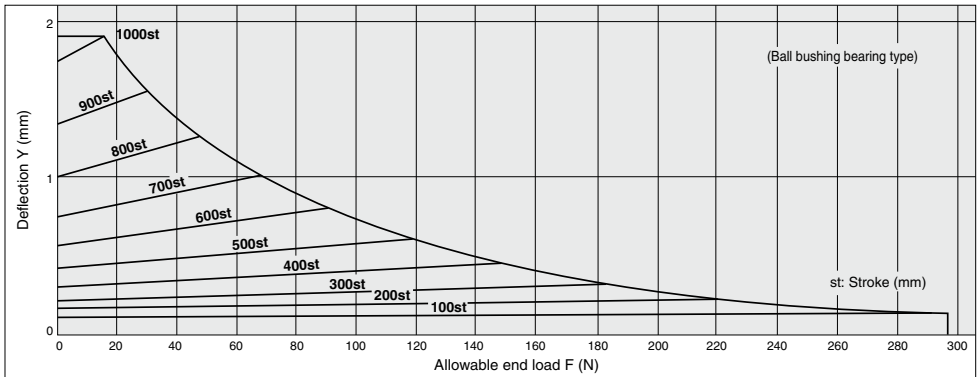

MGJ

JMGP

MGP

MGPW

MGQ

MGG

MGC

MGF

MGT

MGT

D-□

-X□

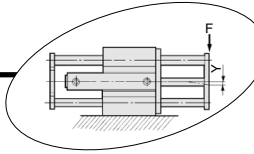

Slide Bearing Allowable End Load and Deflection

MGG □20-Stroke

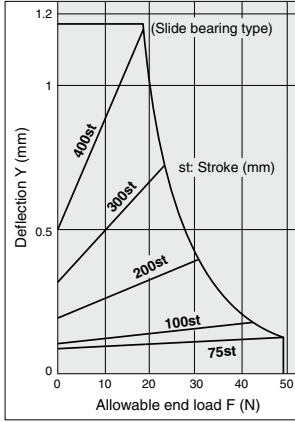

MGG □25-Stroke

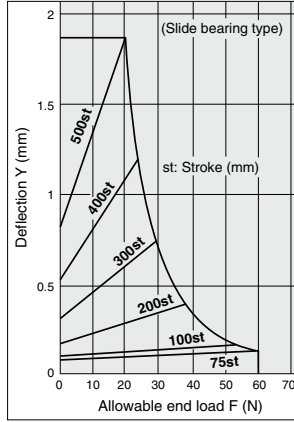

MGG □32-Stroke

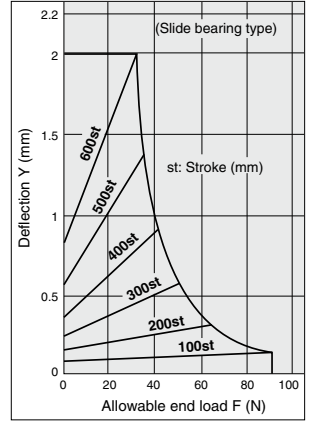

MGG □40-Stroke

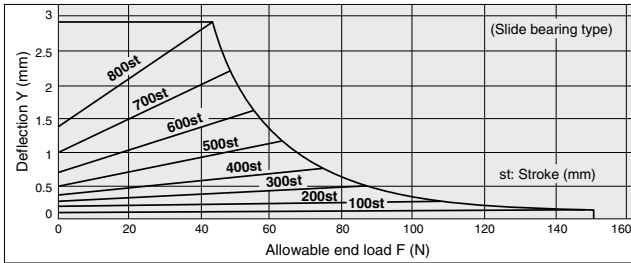

MGG □50-Stroke

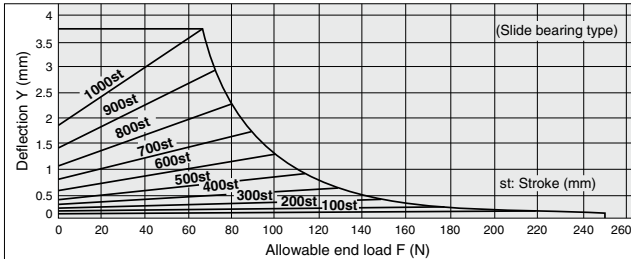

MGGM 63-Stroke

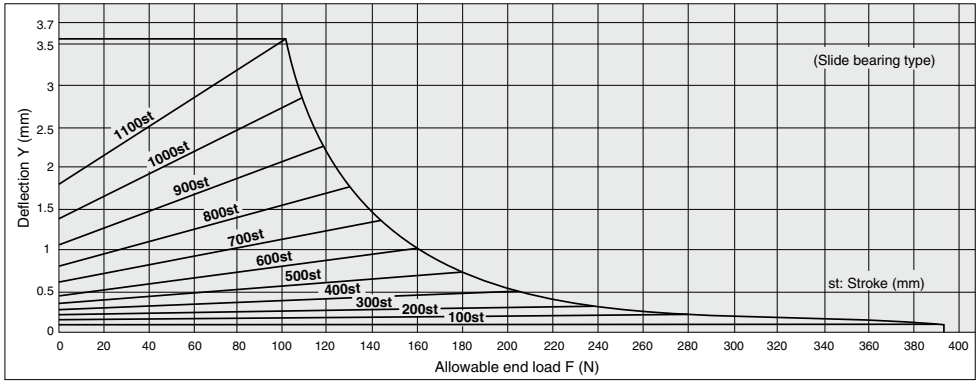

MGGM 80-Stroke

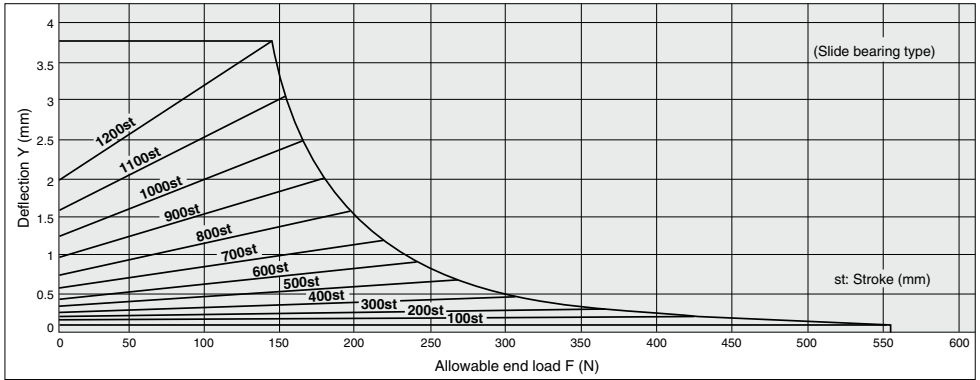

MGGM 100-Stroke

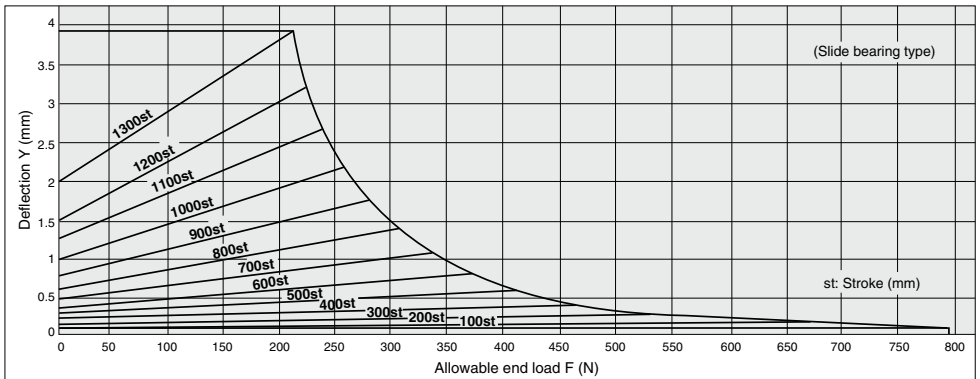

MGG

JMGP

MGP

MGPW

MGQ

MGG

MGC

MGF

MGZ

MGT

D-□

-X□

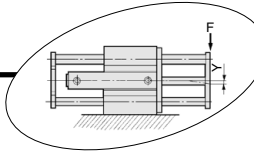

Ball Bushing Bearing Allowable End Load and Deflection

MGGL 20-Stroke

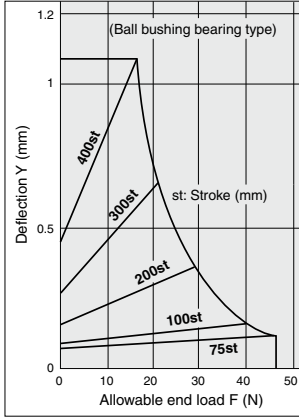

MGGL 25-Stroke

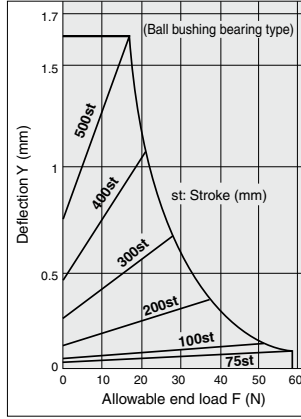

MGGL 32-Stroke

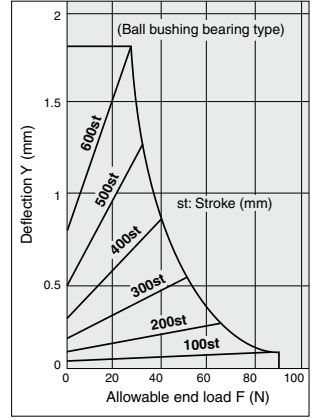

MGGL 40-Stroke

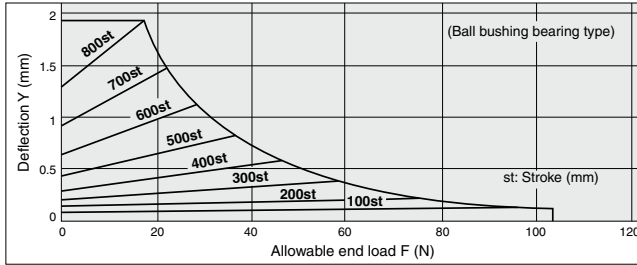

MGGL 50-Stroke

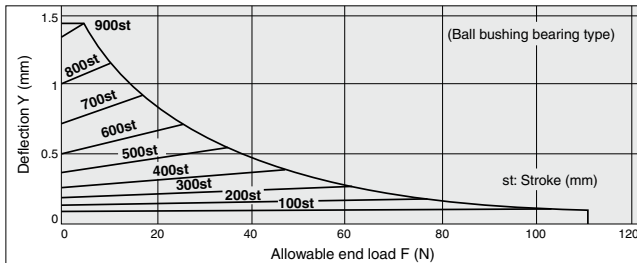

MGGL□63-Stroke

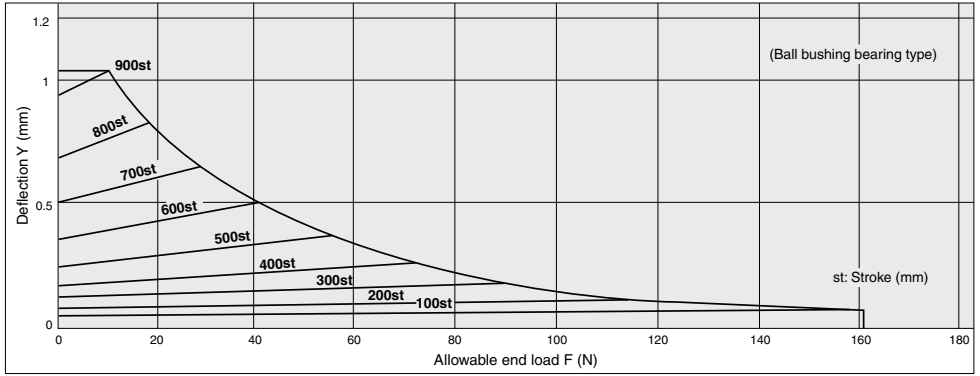

MGGL□80-Stroke

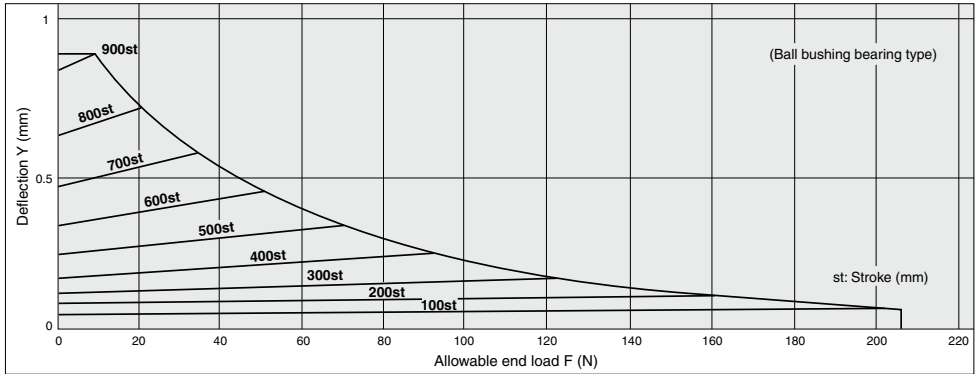

MGGL□100-Stroke

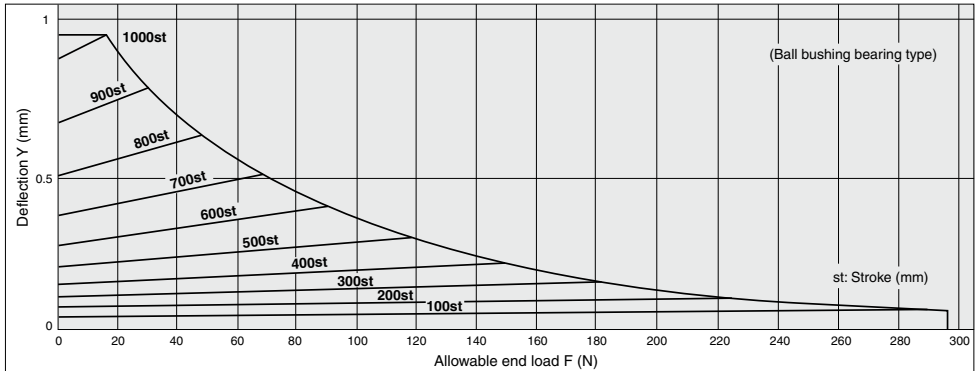

MGJ

JMGP

MGP

MGPW

MGQ

MGG

MGC

MGF

MGZ

MGT

D-□

-X□

Allowable Eccentric Load

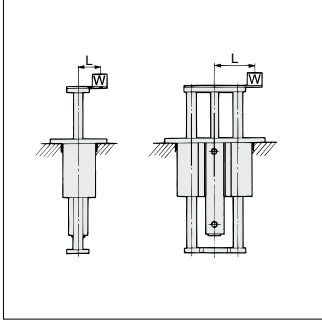

Slide Bearing: MGGM □ □ - □ Stroke

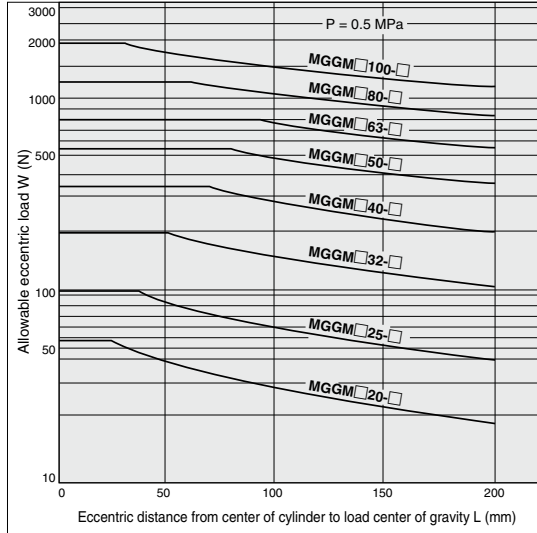

(Set the maximum allowable load so that it does not exceed the following percentages of the theoretical output: 35% for ø20, 40% for ø25, 50% for ø32, 55% for ø40 and ø50, and 50% for ø63, ø80 and ø100.)

Ball Bushing Bearing: MGGL □ □ - □ Stroke

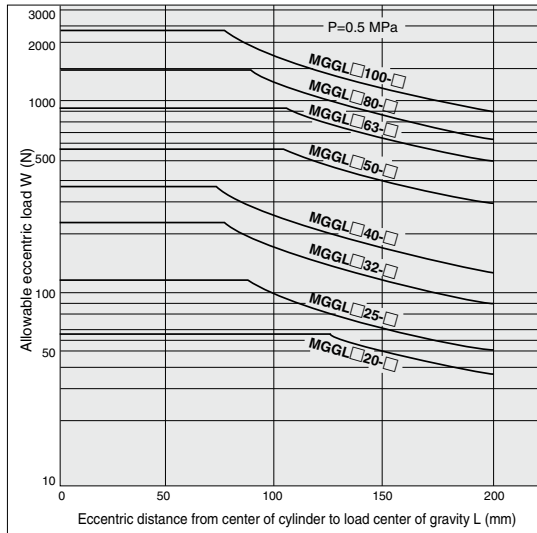

(Set the maximum allowable load so that it does not exceed the following percentages of the theoretical output: 40% for ø20, 50% for ø25, and 60% for ø32, ø40, ø50, ø63, ø80 and ø100.)

Construction

ø20 to ø50/MGG□□

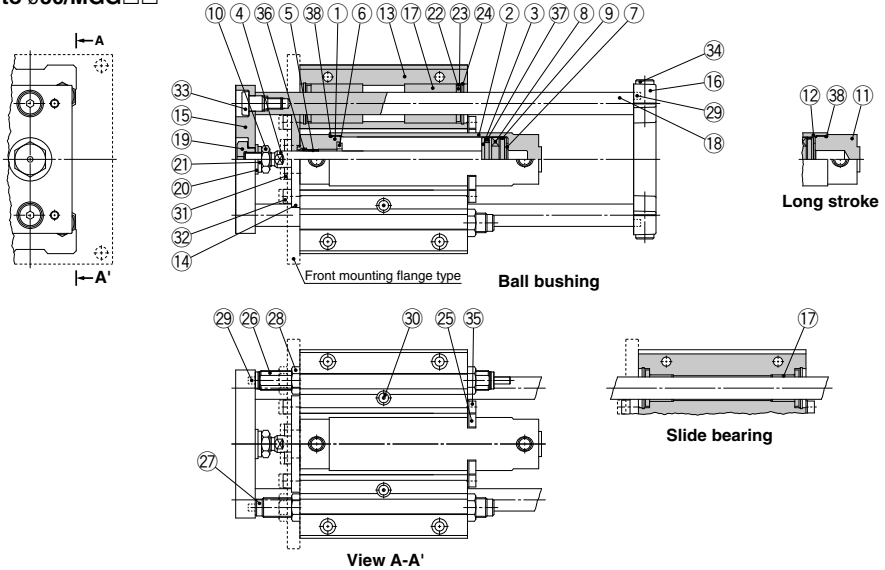

Component Parts

No.	Description	Material	Note
1	Rod cover	Aluminum alloy	Hard anodized
2	Tube cover	Aluminum alloy	Hard anodized
3	Piston	Aluminum alloy	
4	Piston rod	Stainless steel	For ø20, ø25
5	Bushing	Bearing alloy	Hard chrome plating For ø32 to ø100
6	Bumper	Urethane	ø32 or larger is common.
7	Bumper	Urethane	
8	Magnet	—	
9	Wear ring	Resin	
10	Rod end nut	Carbon steel	Zinc chromated
11	Head cover	Aluminum alloy	Hard anodized For long stroke
12	Cylinder tube	Aluminum alloy	Hard anodized
13	Guide body	Aluminum alloy	Anodized
14	Small flange	Carbon steel	Nickel plating For basic type
14	Large flange	Carbon steel	Nickel plating For front mounting flange type
15	Front plate	Carbon steel	Nickel plating
16	Rear plate	Cast iron	Painted
17	Slide bearing	Bearing alloy	For slide bearing
17	Ball bushing	—	For ball bushing
18	Guide rod	Carbon steel	Hard chrome plating For slide bearing
18	Guide rod	Carbon steel	Quenched, hard chrome plating For ball bushing
19	End bracket	Carbon steel	Nickel plating
20	Flat washer	Carbon steel	Zinc chromated
21	Spring washer	Carbon steel	Zinc chromated
22	Felt	Felt	
23	Holder	Stainless steel	
24	Type C retaining ring for hole	Carbon tool steel	Phosphate coated
25	Bracket	Stainless steel	
26	Shock absorber	—	
27	Adjustment bolt	Carbon steel	Nickel plating
28	Nut	Carbon steel	Nickel plating
29	Parallel pin	Carbon steel	Quenched, nickel plating
30	Nipple	—	Nickel plating
31	Hexagon socket head cap screw	Carbon steel	Zinc chromated For cylinder mounting
32	Hexagon socket head cap screw	Carbon steel	Zinc chromated For large/small flange mounting

Component Parts

No.	Description	Material	Note
33	Guide bolt	Carbon steel	Nickel plating For front plate mounting
34	Hexagon socket head cap screw	Carbon steel	Zinc chromated For rear plate mounting
35	Hexagon socket head cap screw	Carbon steel	Zinc chromated For bracket mounting
36	Rod seal	NBR	
37	Piston seal	NBR	
38	Tube gasket	NBR	

Replacement Parts: Seal Kit

Bore size (mm)	Kit no.	Contents
20	CG1N20Z-PS	Set of nos. above 36, 37, 38.
25	CG1N25Z-PS	
32	CG1N32Z-PS	
40	CG1N40Z-PS	

Note) Refer to the following precautions for disassembly/replacement.

Order with the kit number according to the bore size.

* Seal kit includes a grease pack (10 g). Order with the following part number when only the grease pack is needed.

Grease pack part no.: GR-S-010 (10 g)

⚠ Caution

- Do not replace the bushings.
- To replace a seal, apply grease to the new seal before installing it. If the cylinder is put into operation without applying grease to the seal, it could cause the seal to wear significantly, leading to premature air leakage.
- Basic cylinders with a bore size of ø50 cannot be disassembled. When disassembling cylinders with bore sizes of ø20 through ø40, grip the double flat part of either the tube cover or the rod cover with a vise and loosen the other side with a wrench or a monkey wrench etc., and then remove the cover. When retightening, tighten approximately 2 degrees more than the original position. (Cylinders with ø50 or larger bore sizes are tightened with a large tightening torque and cannot be disassembled. If disassembly is required, please contact SMC.)

MGG

JMGW

MGP

MGPW

MGQ

MGG

MGC

MGF

MGZ

MGT

D-□

-X□

MGG Series

Construction

ø63 to ø100/MGG□B

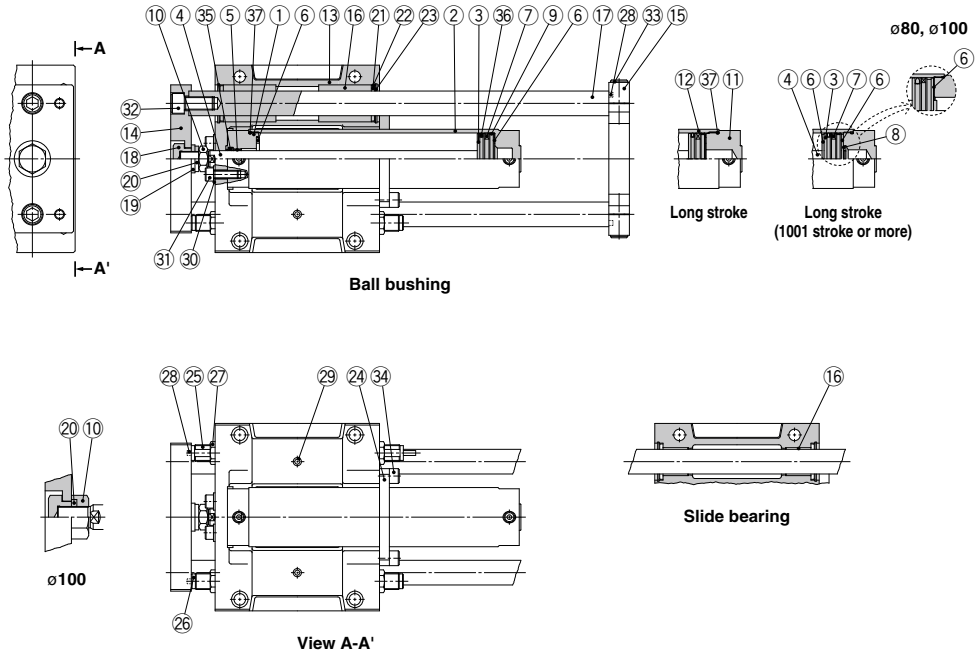

Component Parts

No.	Description	Material	Note
1	Rod cover	Aluminum alloy	Hard anodized
2	Tube cover	Aluminum alloy	Hard anodized
3	Piston	Aluminum alloy	
4	Piston rod	Carbon steel	Hard chrome plating
5	Bushing	Bearing alloy	
6	Bumper	Urethane	
7	Magnet	—	
8	Retaining ring	Stainless steel	For ø63 with 1001 stroke or more
9	Wear ring	Resin	
10	Rod end nut	Carbon steel	Zinc chromated
11	Head cover	Aluminum alloy	Hard anodized
12	Cylinder tube	Aluminum alloy	Hard anodized
13	Guide body	Aluminum alloy	Painted
14	Front plate	Carbon steel	Nickel plating
15	Rear plate	Cast iron	Painted
16	Slide bearing	Bearing alloy	For slide bearing
17	Ball bushing	—	For ball bushing
17	Guide rod	Carbon steel	Hard chrome plating
		Carbon steel	Quenched, hard chrome plating
18	End bracket	Carbon steel	Nickel plating
19	Flat washer	Carbon steel	Zinc chromated
20	Spring washer	Carbon steel	Zinc chromated
21	Felt	Felt	

Component Parts

No.	Description	Material	Note
22	Holder	Carbon steel	Nickel plating
23	Type C retaining ring for hole	Carbon tool steel	Phosphate coated
24	Bracket	Aluminum alloy	Anodized
25	Shock absorber	—	
26	Adjustment bolt	Carbon steel	Nickel plating
27	Nut	Carbon steel	Nickel plating
28	Parallel pin	Carbon steel	Zinc chromated
29	Nipple	—	Nickel plating
30	Fiat washer	Carbon steel	Zinc chromated
31	Hexagon socket head cap screw	Carbon steel	Zinc chromated
32	Hexagon socket head cap screw	Carbon steel	Zinc chromated
33	Hexagon socket head cap screw	Carbon steel	Zinc chromated
34	Hexagon socket head cap screw	Carbon steel	Zinc chromated
35	Rod seal	NBR	
36	Piston seal	NBR	
37	Tube gasket	NBR	

⚠ Caution

Cylinders with ø50 or larger bore sizes are tightened with a large tightening torque and cannot be disassembled. If disassembly is required, please contact SMC.

Construction

ø63 to ø100/MGG□F

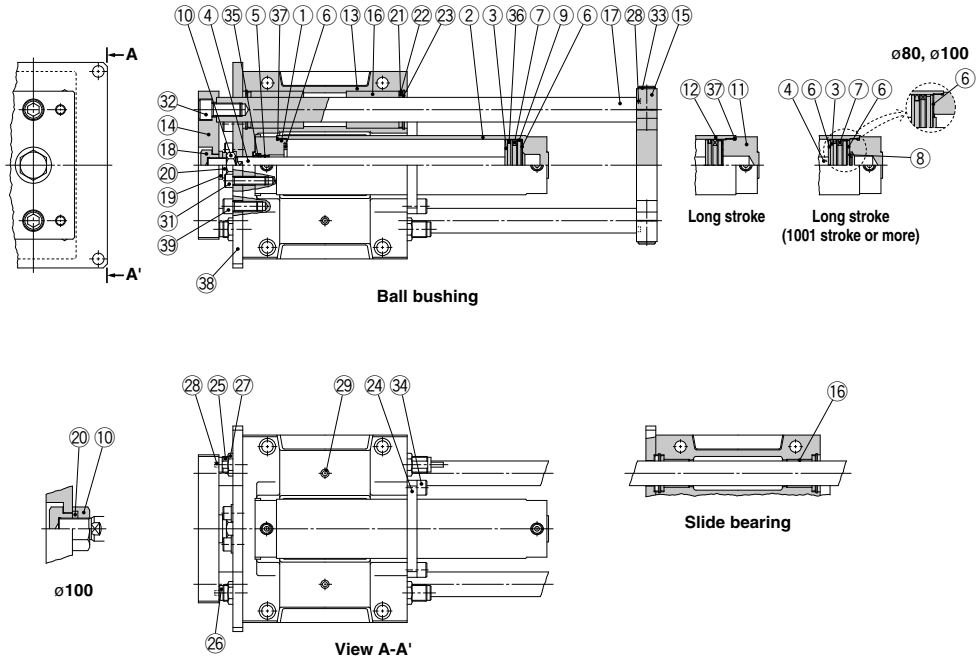

Component Parts

No.	Description	Material	Note
1	Rod cover	Aluminum alloy	Hard anodized
2	Tube cover	Aluminum alloy	Hard anodized
3	Piston	Aluminum alloy	
4	Piston rod	Carbon steel	Hard chrome plating
5	Bushing	Bearing alloy	
6	Bumper	Urethane	
7	Magnet	—	
8	Retaining ring	Stainless steel	For ø63 with 1001 stroke or more
9	Wear ring	Resin	
10	Rod end nut	Carbon steel	Zinc chromated
11	Head cover	Aluminum alloy	Hard anodized For long stroke
12	Cylinder tube	Aluminum alloy	Hard anodized
13	Guide body	Aluminum alloy	Painted
14	Front plate	Carbon steel	Nickel plating
15	Rear plate	Cast iron	Painted
16	Slide bearing	Bearing alloy	For slide bearing
	Ball bushing	—	For ball bushing
17	Guide rod	Carbon steel	Hard chrome plating For slide bearing
		Carbon steel	Quenched, hard chrome plating For ball bushing
18	End bracket	Carbon steel	Nickel plating
19	Flat washer	Carbon steel	Zinc chromated Not required for ø100
20	Spring washer	Carbon steel	Zinc chromated
21	Felt	Felt	
22	Holder	Carbon steel	Nickel plating

Component Parts

No.	Description	Material	Note
23	Type C retaining ring for hole	Carbon tool steel	Phosphate coated
24	Bracket	Aluminum alloy	Anodized
25	Shock absorber	—	
26	Adjustment bolt	Carbon steel	Nickel plating
27	Nut	Carbon steel	Nickel plating
28	Parallel pin	Carbon steel	Zinc chromated
29	Nipple	—	Nickel plating
30	—	—	
31	Hexagon socket head cap screw	Carbon steel	Zinc chromated For cylinder mounting
32	Hexagon socket head cap screw	Carbon steel	Zinc chromated For front plate mounting
33	Hexagon socket head cap screw	Carbon steel	Zinc chromated For rear plate mounting
34	Hexagon socket head cap screw	Carbon steel	Zinc chromated For bracket mounting
35	Rod seal	NBR	
36	Piston seal	NBR	
37	Tube gasket	NBR	
38	Large flange	Carbon steel	Nickel plating
39	Hexagon socket head cap screw	Carbon steel	Zinc chromated For large flange mounting

Caution

Cylinders with ø50 or larger bore sizes are tightened with a large tightening torque and cannot be disassembled. If disassembly is required, please contact SMC.

MGG

JMP

MGP

MGPW

MGO

MGG

MGC

MGF

MGZ

MGT

D-□

-X□

MGG Series

Dimensions

Basic type: MGG□B
 $\phi 20$ to $\phi 50$

Bracket Mounting Stroke

Bore size (mm)	Bracket mounting stroke
20	100 st or more
25	125 st or more
32	150 st or more
40	200 st or more
50	250 st or more

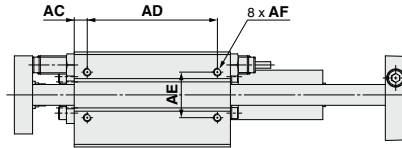
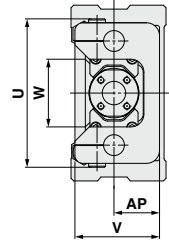
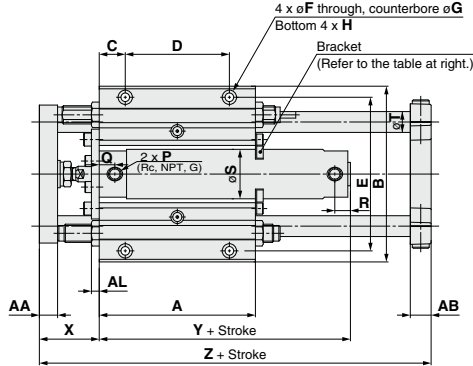
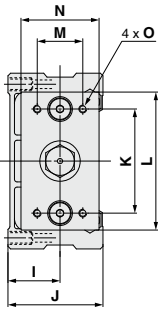

Bore size (mm)	Stroke range (mm)	A	AA	AB	AC	AD	AE	AF	AL	AP	B	C	D	E	F	G	H	I	J	K	L	M	N
20	75, 100, 125, 150, 200	90	11	11	7.5	75	30	M5 x 0.8 depth 10	6	25	108	15	60	92	5.5	9.5 depth 6	M8 x 1.25 depth 14	30	55	60	80	25	45
25	75, 100, 125, 150	100	14	13	7.5	85	30	M6 x 1 depth 12	6	30	130	17.5	65	113	6.6	11 depth 8	M10 x 1.5 depth 18	35	65	70	100	35	54
32	120, 140, 160, 180, 200	120	14	16	10	100	35	M6 x 1 depth 12	6	35	135	20	80	118	6.6	11 depth 8	M10 x 1.5 depth 18	40	73	80	106	35	60
40	200, 250, 300	140	17	19	10	120	40	M8 x 1.25 depth 16	9	45	170	20	100	150	9	14 depth 10	M12 x 1.75 depth 21	50	93	95	134	50	75
50	250, 300, 350, 400, 450, 500	170	23	21	10	150	45	M10 x 1.5 depth 20	9	50	194	25	120	170	11	17 depth 12	M14 x 2 depth 25	55	103	115	152	56	90

Long Stroke

Bore size (mm)	O	Rc, NPT port		G port		R	S	T	U	V	W	X	Y	Z	Bore size (mm)	Stroke range (mm)	Rc, NPT port		G port	
		P	Q	P	Q												R	R	Y	
20	M6 x 1 depth 9	1/8	12	M5 x 0.8	12	12	26	12	82	48	40	39	71	157	20	250 to 400	14	14	79	
25	M6 x 1 depth 13	1/8	12	M5 x 0.8	12.5	12	31	13	100	57	46	46	71	175	25	350 to 500	14	14.5	79	
32	M6 x 1 depth 13	1/8	12	1/8	10.5	12	38	16	114	65	52	46	73	201	32	350 to 600	14	12.5	81	
40	M8 x 1.25 depth 16	1/8	13	1/8	13	12	47	20	138	84	62	56	80	238	40	350 to 800	15	12	89	
50	M10 x 1.5 depth 21	1/4	14	1/4	14	14	58	25	164	94	75	67	92	285	50	350 to 1000	16	16	104	

Dimensions

Basic type: MGG□B
 ø63 to ø100

Bracket Mounting Stroke

Bore size (mm)	Bracket mounting stroke
63	300 st or more
80	400 st or more
100	500 st or more

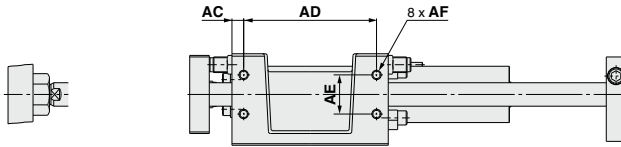
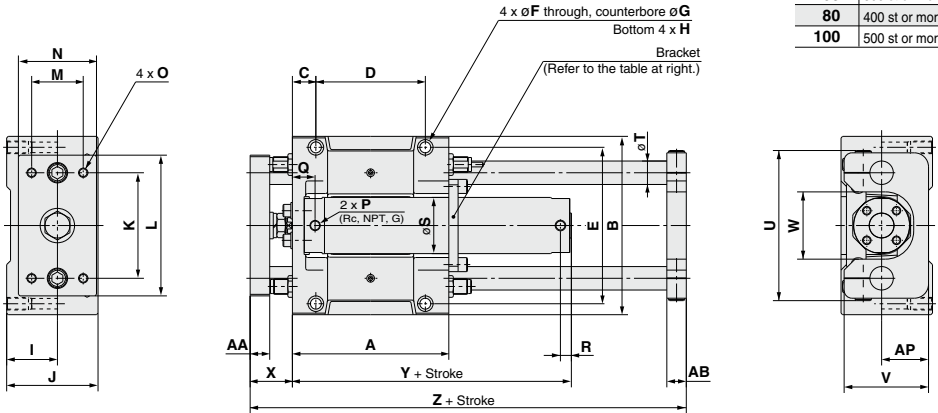

ø100 piston rod end connection

Bore size (mm)	Stroke range (mm)	A	AA	AB	AC	AD	AE	AF	AP	B	C	D	E	F	G	H	I	J	K	L	M	N
63	75, 100	200	25	25	15	170	50	M12 x 1.75 depth 24	60	228	30	140	200	13.5	20 depth 14.5	M16 x 2 depth 28	65	117	135	180	66	100
	125, 150	230	30	27	15	200	55	M12 x 1.75 depth 24	70	262	30	170	234	13.5	20 depth 14.5	M16 x 2 depth 28	75	138	160	214	76	115
80	200, 250	280	32	30	17.5	245	70	M14 x 2 depth 28	80	304	35	210	274	15	23 depth 17	M18 x 2.5 depth 32	85	153	190	245	80	125
	300																					

(mm)

Bore size (mm)	O	P	Q	R	S	T	U	V	W	X	Y	Z
63	M12 x 1.75 depth 23	1/4	29	14	72	30	192	108	86	54	107	308
80	M12 x 1.75 depth 28	3/8	40	19	89	35	224	128	104	66	131	355
100	M14 x 2 depth 30	1/2	40	19	110	40	262	143	128	66	131	410

Long Stroke

Bore size (mm)	Stroke range (mm)	R	Y
63	350 to 1100	16	119
80	350 to 1200	23	145
100	350 to 1300	23	145

Note) Rc, NPT and G ports can be selected.

- MGJ
- JMP
- MGP
- MGPW
- MGQ
- MGG**
- MGC
- MGF
- MGT

- D-□
- X□

MGG Series

Dimensions

Front mounting flange type: MGG□F
 ø20 to ø50

Bracket Mounting Stroke

Bore size (mm)	Bracket mounting stroke
20	100 st or more
25	125 st or more
32	150 st or more
40	200 st or more
50	250 st or more

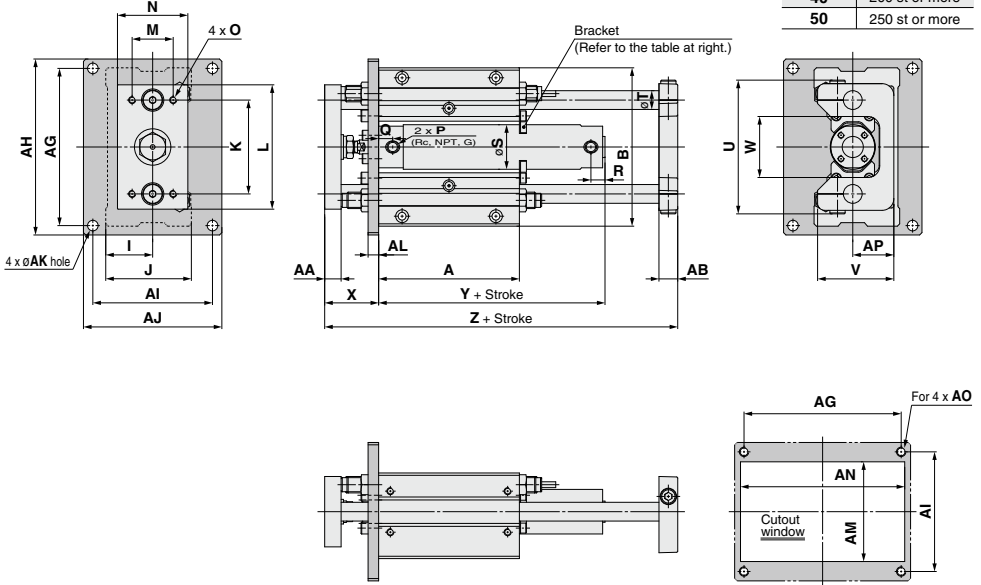

Mounting dimensions

Bore size (mm)	Stroke range (mm)	A	AA	AB	AG	AH	AI	AJ	AK	AL	AM	AN	AO	AP	B	I	J	K	L	M	N	O
20	75, 100, 125, 150, 200	90	11	11	112	125	82	95	6.6	9	65	115	M6	25	108	30	55	60	80	25	45	M6 x 1 depth 9
25	75, 100 125, 150	100	14	13	134	150	92	108	9	9	75	135	M8	30	130	35	65	70	100	35	54	M6 x 1 depth 13
32		120	14	16	134	150	102	118	9	9	85	140	M8	35	135	40	73	80	106	35	60	M6 x 1 depth 13
40	200, 250	140	17	19	170	186	134	150	9	12	105	175	M8	45	170	50	93	95	134	50	75	M8 x 1.25 depth 16
50	300	170	23	21	190	210	140	160	11	12	115	200	M10	50	194	55	103	115	152	56	90	M10 x 1.5 depth 21

Bore size (mm)	Rc, NPT port		G port		R	S	T	U	V	W	X	Y	Z
	P	Q	P	Q									
20	1/8	12	M5 x 0.8	12	12	26	12	82	48	40	39	71	157
25	1/8	12	M5 x 0.8	12.5	12	31	13	100	57	46	46	71	175
32	1/8	12	1/8	10.5	12	38	16	114	65	52	46	73	201
40	1/8	13	1/8	13	12	47	20	138	84	62	56	80	238
50	1/4	14	1/4	14	14	58	25	164	94	75	67	92	285

Bore size (mm)	Stroke range (mm)	Rc, NPT port	G port	Y
		R	R	
20	250 to 400	14	14	79
25	350 to 500	14	14.5	79
32	350 to 600	14	12.5	81
40	350 to 800	15	12	89
50	350 to 1000	16	16	104

Dimensions

Front mounting flange type: **MGG□F**
 ø63 to ø100

Bracket Mounting Stroke

Bore size (mm)	Bracket mounting stroke
63	300 st or more
80	400 st or more
100	500 st or more

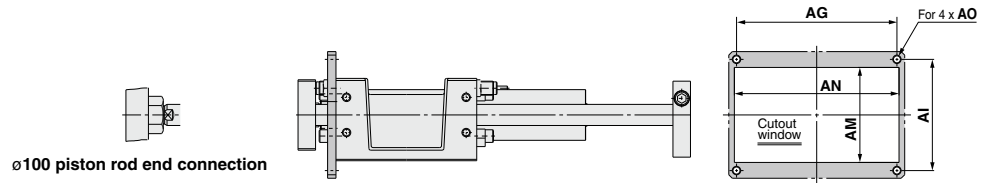
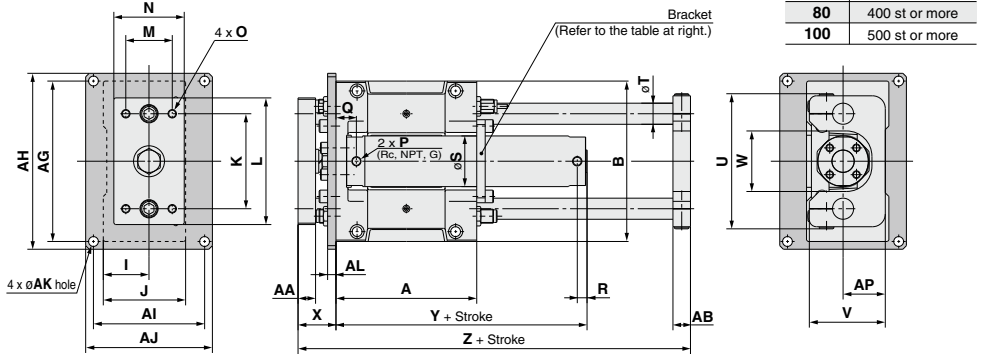

Mounting dimensions

Bore size (mm)	Stroke range (mm)	A	AA	AB	AG	AH	AI	AJ	AK	AL	AM	AN	AO	AP	B	I	J	K	L	M	N	O	P*
63	75, 100	200	25	25	228	250	158	180	14	12	135	234	M12	60	228	65	117	135	180	66	100	M12 x 1.75 depth 23	1/4
80	125, 150 200, 250	230	30	27	262	284	178	200	14	16	155	268	M12	70	262	75	138	160	214	76	115	M12 x 1.75 depth 28	3/8
100	300	280	32	30	300	326	200	226	16	16	175	310	M14	80	304	85	153	190	245	80	125	M14 x 2 depth 30	1/2

Long Stroke

Bore size (mm)	Q	R	S	T	U	V	W	X	Y	Z
63	29	14	72	30	192	108	86	54	107	308
80	40	19	89	35	224	128	104	66	131	355
100	40	19	110	40	262	143	128	66	131	410

Bore size (mm)	Stroke range (mm)	R	Y
63	350 to 1100	16	119
80	350 to 1200	23	145
100	350 to 1300	23	145

Note) Rc, NPT and G ports can be selected.

- MGGJ**
- JMGP**
- MGP**
- MGPW**
- MGQ**
- MGG**
- MGC**
- MGF**
- MGZ**
- MGT**

- D-□
- X□

Guide Cylinder/With End Lock

MGG Series

ø20, ø25, ø32, ø40, ø50, ø63, ø80, ø100

How to Order

MGG L B 32 - **100** - **H N** - **M9BW** - **C**

Guide Cylinder
Bearing type
 M Slide bearing
 L Ball bushing bearing

Mounting type
 B Basic type
 F Front mounting flange type

Bore size

20	20 mm	50	50 mm
25	25 mm	63	63 mm
32	32 mm	80	80 mm
40	40 mm	100	100 mm

Port thread type
 Nil Rc
 TN NPT
 TF G

Cylinder stroke (mm)
 Refer to "Standard Stroke" on page 559.

Lock position
 H Head end lock
 R Rod end lock

Auto switch
 Nil Without auto switch (Built-in magnet)

Auto switch mounting bracket^(Note)
 Note) This symbol is indicated when the D-A9□ or M9□ type auto switch is specified. This mounting bracket does not apply to other auto switches (D-C7□ and H7□, etc.) (Nil)

Number of auto switches
 Nil 2 pcs.
 S 1 pc.
 n "n" pcs.

Manual release type
 N Non-lock type
 L Lock type

Made to Order
 Refer to page 560 for details.

* For the applicable auto switch model, refer to the table below.

Applicable Auto Switches

Refer to pages 1119 to 1245 for further information on auto switches.

Type	Special function	Electrical entry	Indicator/light	Wiring (Output)	Auto switch model		Auto switch model				Lead wire length (m)				Pre-wired connector	Applicable load			
					DC	AC	Applicable bore (mm)		0.5 (Nil)	1 (M)	3 (L)	5 (Z)	None (N)						
							ø20 to ø63	ø80, ø100						Perpendicular In-line			In-line		
Solid state auto switch	—	Grommet	Yes	3-wire (NPN)	5 V, 12 V	—	M9NV	M9N	—	●	●	○	—	○	IC circuit	Relay, PLC			
							—	G59	—	●	●	○	—	○					
		M9PV		M9P	—	●	●	○	—	○									
		—		G5P	—	●	●	○	—	○									
	Diagnostic indication (2-color indicator)	Connector	Yes	3-wire (NPN)	24 V	5 V, 12 V	—	M9BV	M9B	—	●	●	○	—	○		—		
								—	H7C	—	●	—	●	●	—			—	
	Water resistant (2-color indicator)	Grommet	Yes	3-wire (NPN)	5 V, 12 V	—	—	M9NWV	M9NW	—	●	●	○	—	○		IC circuit		
								M9PWV	M9PW	—	●	●	○	—	○				
	With diagnostic output (2-color indicator)	Connector	Yes	2-wire	12 V	—	—	M9BVV	M9BV	—	●	●	○	—	○		—		
								—	K59W	—	●	—	●	○	—			○	
Reed auto switch	—	Grommet	Yes	3-wire (NPN equivalent)	5 V	—	A96V	A96	—	●	—	●	—	—	IC circuit	Relay, PLC			
							—	A93V ^{#2}	A93	—	●	●	●	—			—		
		Connector		No	2-wire	24 V	12 V	—	100 V or less	A90V	A90	—	●	—	●		—	IC circuit	
									100 V, 200 V	—	B54	—	●	—	●		—		—
	Diagnostic indication (2-color indicator)	Grommet	Yes	No	—	—	—	200 V or less	—	B64	—	●	—	●	—		—		
								—	C73C	—	●	—	●	●	—			—	
								24 V or less	—	C80C	—	●	—	●	●			—	IC circuit
								—	—	B59W	—	●	—	●	—			—	

*1 Water resistant type auto switches can be mounted on the above models, but in such case SMC cannot guarantee water resistance.

Consult with SMC regarding water resistant types with the above model numbers.

*2 2 m type lead wire is only applicable to D-A93.

*3 Lead wire length symbols: 0.5 m Nil (Example) M9NW

1 m M (Example) M9NWM

3 m L (Example) M9NWL

5 m Z (Example) M9NWZ

None N (Example) H7CN

* Solid state auto switches marked with "○" are produced upon receipt of order.

* Since there are other applicable auto switches than listed, refer to page 570 for details.

* For details about auto switches with pre-wired connector, refer to pages 1192 and 1193.

* D-A9□(V)/M9□(V)/M9□W(V)/M9□A(V) auto switches are shipped together (not assembled).

(Only switch mounting brackets are assembled at the time of shipment.)

Caution

When using auto switches shown inside (), stroke end detection may not be possible depending on the One-touch fitting or speed controller model. Please contact SMC in this case.

Specifications

Symbol Rubber bumper

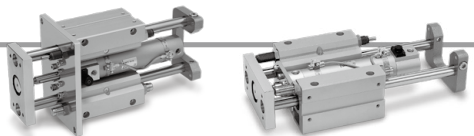

Standard Stroke

Model (Bearing type)	Bore size (mm)	Standard stroke (mm)	Long stroke (mm)
MGGM(Slide bearing) MGG(LBall bushing bearing)	20	75, 100, 125, 150, 200, 250, 300	250, 300, 350, 400
	25		350, 400, 450, 500
	32		350, 400, 450, 500, 600
	40		350, 400, 450, 500, 600, 700, 800
	50		350, 400, 450, 500, 600, 700, 800, 900, 1000
	63		350, 400, 450, 500, 600, 700, 800, 900, 1000, 1100
	80		350, 400, 450, 500, 600, 700, 800, 900, 1000, 1100, 1200
	100	350, 400, 450, 500, 600, 700, 800, 900, 1000, 1100, 1200, 1300	

* Intermediate strokes and short strokes other than the above are produced upon receipt of order.

Specifications

Model	MGG□□20	MGG□□25	MGG□□32	MGG□□40	MGG□□50	MGG□□63	MGG□□80	MGG□□100
Basic cylinder	CDBG1BN Bore size Port thread type Stroke Lock position Manual release Auto switch -XC70							
Bore size (mm)	20	25	32	40	50	63	80	100
Action	Double acting							
Fluid	Air							
Proof pressure	1.5 MPa							
Maximum operating pressure	1.0 MPa							
Minimum operating pressure	0.15 MPa (Horizontal with no load)							
Ambient and fluid temperature	-10 to 60°C							
Piston speed	50 to 1000 mm/s					50 to 700 mm/s		
Cushion	Basic cylinder	Rubber bumper						
	Guide unit	Built-in shock absorbers (2 pcs.)						
Stroke adjusting range (One side) [Built-in adjusting bolts (2 pcs.)]	0 to -10 mm	0 to -15 mm						
Base cylinder lubrication	Non-lube							
Stroke length tolerance	+1.9 mm(1000 st or less), +2.3 mm(1001 st or more)							
Non-rotating accuracy	Slide bearing	±0.07°	±0.06°	±0.06°	±0.05°	±0.04°	±0.04°	±0.03°
	Ball bushing bearing	±0.06°	±0.05°	±0.04°	±0.04°	±0.04°	±0.03°	±0.02°
Piping port size (Rc, NPT, G)	1/8				1/4		3/8	1/2

* When the cylinder is retracted (initial value), the non-rotating accuracy without loads or deflection of the guide rods will be below the values shown in the table above as a guideline.

Lock Specifications

Bore size (mm)	20	25	32	40	50	63	80	100
Holding force (Max.) (N)	215	330	550	860	1340	2140	3450	5390
Lock position	Head end, Rod end							
Backlash	2 mm or less							
Manual release	Non-lock type, Lock type							

* Adjust switch positions for operation at both the stroke end and backlash (2 mm) movement positions.

Shock Absorber Specifications

Shock absorber model	RB1007	RB1412	RB2015	RB2725	
Applicable guide cylinder	MGG□□20	MGG□□25, 32	MGG□□40, 50, 63	MGG□□80, 100	
Maximum energy absorption (J)	5.88	19.6	58.8	147	
Stroke absorption (mm)	7	12	15	25	
Maximum collision speed (m/s)	5				
Max. operating frequency (cycle/min)*	70	45	25	10	
Ambient temperature range (°C)	-10 to 80				
Spring force (N)	Extended	4.22	6.86	8.34	8.83
	Retracted	6.86	15.98	20.5	20.01

* It denotes the values at the maximum energy absorption per one cycle. Therefore, the operating frequency can be increased according to the energy absorption.

MGGJ

MGGP

MGGP

MGGPW

MGGQ

MGGG

MGGC

MGGF

MGGZ

MGGT

D-□

-X□

Theoretical Output



Bore size (mm)	Rod size (mm)	Operating direction	Piston area (mm ²)	Operating pressure (MPa)								
				0.2	0.3	0.4	0.5	0.6	0.7	0.8	0.9	1.0
20	8	OUT	314	62.8	94.2	126	157	188	220	251	283	314
		IN	264	52.8	79.2	106	132	158	185	211	238	264
25	10	OUT	491	98.2	147	196	246	295	344	393	442	491
		IN	412	82.4	124	165	206	247	288	330	371	412
32	12	OUT	804	161	241	322	402	482	563	643	724	804
		IN	691	138	207	276	346	415	484	553	622	691
40	16	OUT	1260	252	378	504	630	756	882	1010	1130	1260
		IN	1060	212	318	424	530	636	742	848	954	1060
50	20	OUT	1960	392	588	784	980	1180	1370	1570	1760	1960
		IN	1650	330	495	660	825	990	1160	1320	1490	1650
63	20	OUT	3120	624	936	1250	1560	1870	2180	2500	2810	3120
		IN	2800	560	840	1120	1400	1680	1960	2240	2520	2800
80	25	OUT	5030	1010	1510	2010	2520	3020	3520	4020	4530	5030
		IN	4540	908	1360	1820	2270	2720	3180	3630	4090	4540
100	30	OUT	7850	1570	2360	3140	3930	4710	5500	6280	7070	7850
		IN	7150	1430	2150	2860	3580	4290	5010	5720	6440	7150

Note) Theoretical output (N) = Pressure (MPa) x Piston area (mm²)

Weight

Bore size (mm)		20	25	32	40	50	63	80	100		
Basic weight	LB Type (Ball bushing bearing, Basic type)	1.72	2.82	3.84	7.19	11.63	16.6	26.32	37.46		
	LF Type (Ball bushing bearing, Front mounting flange type)	2.44	3.79	4.87	9.38	14.17	20.58	33	45.98		
	MB Type (Slide bearing, Basic type)	1.71	2.79	3.36	7.17	11.36	16.22	25.61	36.36		
	MF Type (Slide bearing, Front mounting flange type)	2.42	3.75	4.39	9.37	13.89	20.2	32.29	44.89		
	Additional weight per each 50 mm of stroke	0.14	0.17	0.25	0.4	0.61	0.82	1.11	1.48		
	Additional weight for long stroke	0.01	0.01	0.02	0.03	0.06	0.1	0.19	0.26		
	Additional weight with bracket	0.011	0.018	0.019	0.031	0.061	0.269	0.384	0.548		
	Additional weight of lock unit	Head end lock (H)	Non-lock type (N)	0.05	0.07	0.08	0.17	0.26	0.44	0.8	1.15
			Lock type (L)	0.07	0.08	0.1	0.21	0.3	0.48	0.88	1.23
		Rod end lock (R)	Non-lock type (N)	0.07	0.08	0.12	0.19	0.31	0.51	0.9	1.31
Lock type (L)			0.09	0.1	0.14	0.23	0.34	0.54	0.97	1.39	

Calculation: (Example) **MGGLB32-500-HN** (Ball bushing type) (Basic type, ø32, 500 st, With bracket)
 • Standard weight 3.84 (LB type) • Additional weight for long stroke 0.02
 • Additional weight for stroke 0.25/50 st • Additional weight with bracket 0.019
 • Stroke 500 st • Additional weight of lock unit 0.08
 $3.84 + 0.25 \times 500/50 + 0.02 + 0.019 + 0.08 = 6.459$ kg (Head side, Non-lock type)

Weight of Moving Parts

Bore size (mm)		20	25	32	40	50	63	80	100
Moving parts basic weight		0.69	1.14	1.61	3.09	5.23	8.29	13.09	18.58
	Additional weight by each 50 mm of stroke	0.109	0.135	0.203	0.326	0.509	0.679	0.948	1.265

Calculating weight of moving parts (Example) **MGGLB32-500-HN**
 • Moving parts basic weight 1.61
 • Additional weight for stroke 0.203/50 st
 • Stroke 500 st
 $1.61 + 0.203 \times 500/50 = 3.64$ kg

Refer to pages 542 to 550 for the allowable end load and deflection, as well as the allowable eccentric load.

Made to Order **Made to Order Specifications**
 (For details, refer to pages 1247 to 1440.)

Symbol	Specifications
-XC79	Machining tapped hole, drilled hole and pin hole additionally

Construction

ø20 to ø100/MGG□□

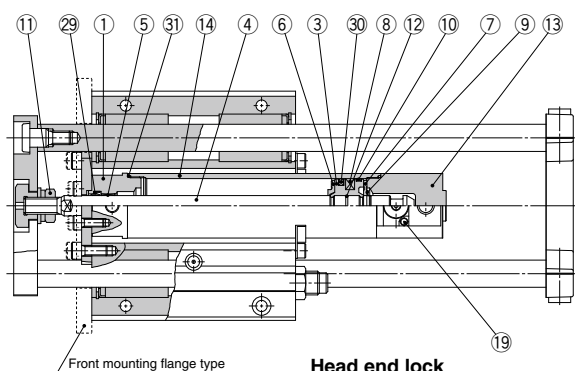

Head end lock

Manual release (Lock type)

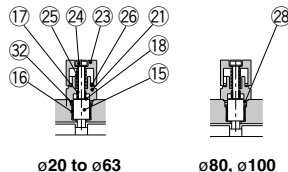

ø20 to ø63

ø80, ø100

Manual release (Non-lock type)

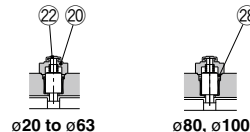

ø20 to ø63

ø80, ø100

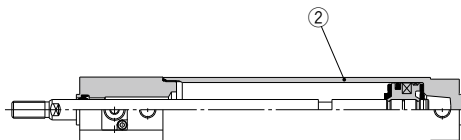

Rod end lock (Base cylinder only)



ø80, ø100

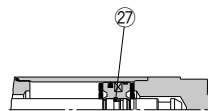

ø40 to ø100

* Since the guide unit, front plate and rear plate figure are the same as the standard type, refer to pages 551 to 553.

Component Parts

No.	Description	Material	Note
1	Rod cover	Aluminum alloy	White hard anodized
2	Tube cover	Aluminum alloy	White hard anodized
3	Piston	Aluminum alloy	Chromated
4	Piston rod	Carbon steel	Hard chrome plated, ø20, ø25 are stainless steel
5	Bushing	Bearing alloy	
6	Bumper A	Urethane	Description is "Bumper" for ø63 and larger
7	Bumper B	Urethane	ø40 or larger: Same as Bumper A
8	Magnet	—	
9	Retaining ring	Stainless steel	Not required for ø80, ø100
10	Wear ring	Resin	
11	Rod end nut	Rolled steel	Nickel plated, ø100 is carbon steel
12	Piston gasket	NBR	
13	Head cover	Aluminum alloy	White hard anodized For head side locking type and long stroke
14	Cylinder tube	Aluminum alloy	Hard anodized
15	Lock piston	Carbon steel	Hard chrome plated, Heat treated
16	Lock bushing	Bearing alloy	
17	Lock spring	Stainless steel	
18	Bumper	Urethane	
19	Hexagon socket head cap screw	Chromium molybdenum steel	Black zinc chromated
20	Cap A	Aluminum die-casted	Black painted For non-lock type
21	Cap B	Carbon steel	Oxide film treated For lock type
22	Rubber cap	Synthetic rubber	For non-lock type
23	M/O knob	Zinc die-casted	Black painted For lock type
24	M/O bolt	Chromium molybdenum steel	Black zinc chromated, Red painted For lock type
25	M/O spring	Steel wire	Zinc chromated For lock type ø20, ø25, ø32: Stainless steel

Component Parts

No.	Description	Material	Note
26	Stopper ring	Carbon steel	Zinc chromated For lock type
27	Piston holder	Urethane	Used for ø40 and larger
28	Seal retainer	Rolled steel	Used for ø80 and ø100
29	Rod seal	NBR	
30	Piston seal	NBR	
31	Tube gasket	NBR	
32	Lock piston seal	NBR	

* Since the guide unit parts are the same as the standard type, refer to pages 551 to 553.

Replacement Parts: Seal Kit

Bore size (mm)	Kit no.	Contents
20	CBG1N20-PS	Set of nos. above ⑳, ㉑, ㉒, ㉓.
25	CBG1N25-PS	
32	CBG1N32-PS	
40	CBG1N40-PS	

* Seal kit includes ㉑ to ㉓. Order the seal kit, based on each bore size.

* Seal kit includes a grease pack (10 g). Order with the following part number when only the grease pack is needed.

Grease pack part no.: GR-S-010 (10 g)

⚠ Caution

Basic cylinders with a bore size of ø50 cannot be disassembled. (Cylinders with ø50 or larger bore sizes are tightened with a large tightening torque and cannot be disassembled. Please contact SMC when disassemble is required.)

MGG

JMGP

MGP

MGPW

MGO

MGG

MGC

MGF

MGZ

MGT

D-□

-X□

MGG Series

Dimensions

Basic type: MGG□B
 $\varnothing 20$ to $\varnothing 50$

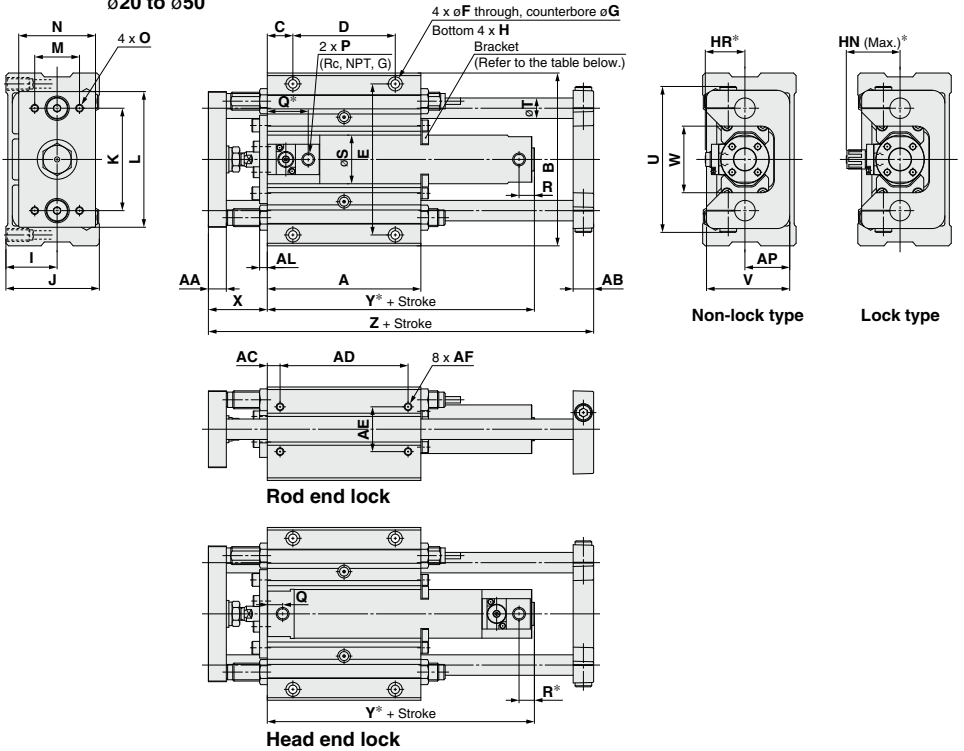

Dimensions not marked with an "*" are the same as standard.

Bore size (mm)	Stroke range (mm)	A	AA	AB	AC	AD	AE	AF	AL	AP	B	C	D	E	F	G	H	I	J	K	L	M	N
20	75, 100, 125, 150, 200	90	11	11	7.5	75	30	M5 x 0.8 depth 10	6	25	108	15	60	92	5.5	9.5 depth 6	M8 x 1.25 depth 14	30	55	60	80	25	45
25	75, 100	100	14	13	7.5	85	30	M6 x 1 depth 12	6	30	130	17.5	65	113	6.6	11 depth 8	M10 x 1.5 depth 18	35	65	70	100	35	54
32	125, 150	120	14	16	10	100	35	M6 x 1 depth 12	6	35	135	20	80	118	6.6	11 depth 8	M10 x 1.5 depth 18	40	73	80	106	35	60
40	200, 250	140	17	19	10	120	40	M8 x 1.25 depth 16	9	45	170	20	100	150	9	14 depth 10	M12 x 1.75 depth 21	50	93	95	134	50	75
50	300	170	23	21	10	150	45	M10 x 1.5 depth 20	9	50	194	25	120	170	11	17 depth 12	M14 x 2 depth 25	55	103	115	152	56	90

Bore size (mm)	O	P*	S	T	U	V	W	X	Z	Bore size (mm)	For lock type		Rod end lock			Head end lock			
											HN*	HR*	Q*	R	Y*	Q	R*	Y*	
20	M6 x 1 depth 9	1/8	26	12	82	48	40	39	157	20	37	25.3	20	38.5	12 (14)	98 (106)	12	11	95
25	M6 x 1 depth 13	1/8	31	13	100	57	46	46	175	25	40	28.3	25	39	12 (14)	98 (106)	12	11	95
32	M6 x 1 depth 13	1/8	38	16	114	65	52	46	201	32	43	31.3	32	40	12 (14)	101 (109)	12	11	97
40	M8 x 1.25 depth 16	1/8	47	20	138	84	62	56	238	40	52.5	38.3	40	41	12 (15)	109 (118)	13	11	111
50	M10 x 1.5 depth 21	1/4	58	25	164	94	75	67	285	50	58.5	44.5	50	47	14 (16)	125 (137)	14	16	128

Note) Rc, NPT and G ports can be selected.

Note) (): Denotes the dimensions for long stroke.

Long Stroke

Bore size (mm)	Stroke range (mm)
20	250 to 400
25	350 to 500
32	350 to 600
40	350 to 800
50	350 to 1000

Bracket Mounting Stroke

Bore size (mm)	Bracket mounting stroke
20	100 st or more
25	125 st or more
32	150 st or more
40	200 st or more
50	250 st or more

Dimensions

Basic type: **MGG□B**
 $\phi 63$ to $\phi 100$

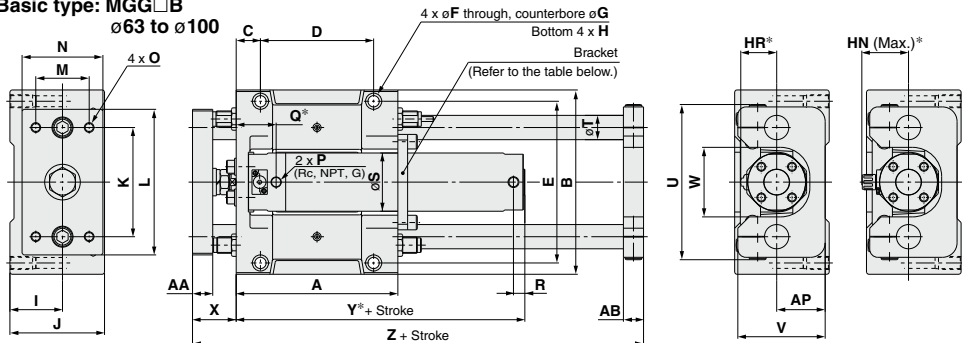

Non-lock type Lock type

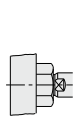

$\phi 100$ piston rod end connection

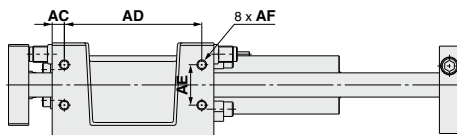

Rod end lock

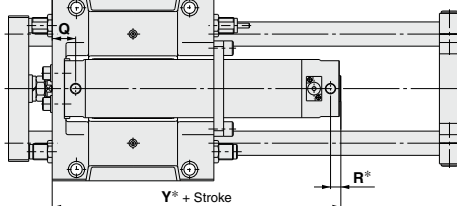

Head end lock

Dimensions not marked with an "*" are the same as standard.

Bore size (mm)	Stroke range (mm)	A	AA	AB	AC	AD	AE	AF	AP	B	C	D	E	F	G	H	I	J	K	L	M	N
63	75, 100, 125	200	25	25	15	170	50	M12 x 1.75 depth 24	60	228	30	140	200	13.5	20 depth 14.5	M16 x 2 depth 28	65	117	135	180	66	100
80	150, 200	230	30	27	15	200	55	M12 x 1.75 depth 24	70	262	30	170	234	13.5	20 depth 14.5	M16 x 2 depth 28	75	138	160	214	76	115
100	250, 300	280	32	30	17.5	245	70	M14 x 2 depth 28	80	304	35	210	274	15	23 depth 17	M18 x 2.5 depth 32	85	153	190	245	80	125

Bore size (mm)	O	P*	S	T	U	V	W	X	Z
63	M12 x 1.75 depth 23	1/4	72	30	192	108	86	54	308
80	M12 x 1.75 depth 28	3/8	89	35	224	128	104	66	355
100	M14 x 2 depth 30	1/2	110	40	262	143	128	66	410

Bore size (mm)	For lock type		For non-lock type
	HN*	HR*	
63	59	45	
80	68	53.5	
100	79	64.5	

Bore size (mm)	Rod end lock			Head end lock		
	Q*	R	Y*	Q	R*	Y*
63	63	14(16)	142(154)	29	15	147
80	82	19(23)	175(189)	40	17	182
100	85	19(23)	180(194)	40	23	188

Note) Rc, NPT and G ports can be selected.

Note) () : Denotes the dimensions for long stroke.

Long Stroke

Bore size (mm)	Stroke range (mm)
63	350 to 1100
80	350 to 1200
100	350 to 1300

Bracket Mounting Stroke

Bore size (mm)	Bracket mounting stroke
63	300 st or more
80	400 st or more
100	500 st or more

- MGJ
- JMP
- MGP
- MGPW
- MGQ
- MGG**
- MGC
- MGF
- MGZ
- MGT

- D-□
- X□

MGG Series

Dimensions

Front mounting flange type: MGG□F ø20 to ø50

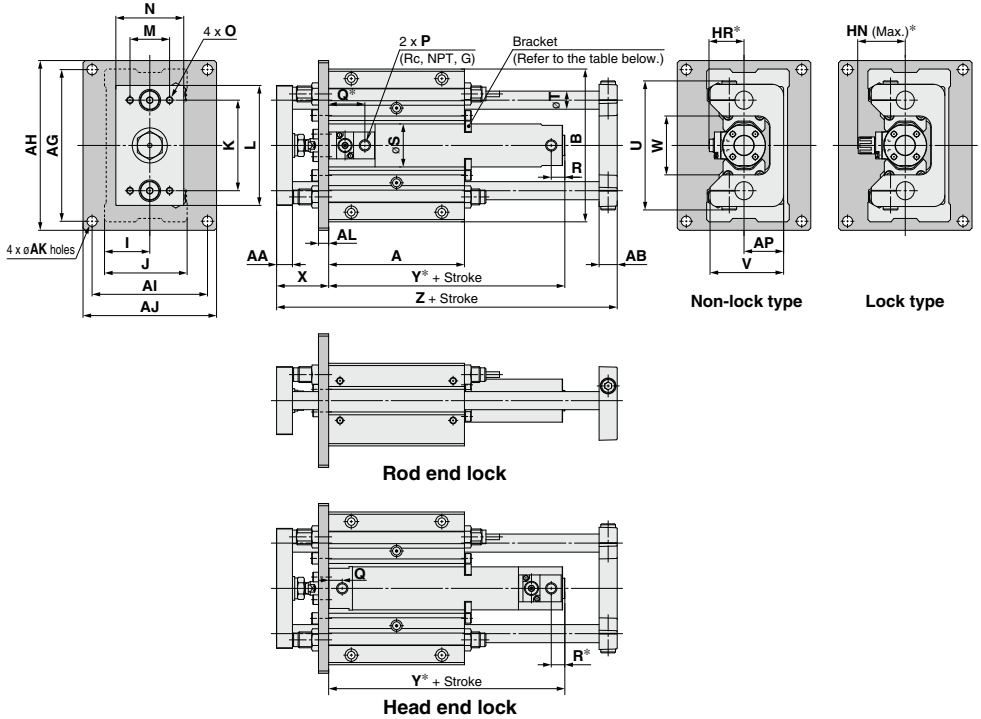

Dimensions not marked with an "*" are the same as standard.

(mm)

Bore size (mm)	Stroke range (mm)	A	AA	AB	AG	AH	AI	AJ	AK	AL	AP	B	I	J	K	L	M	N	O	P*	S	T	U	V
20	75, 100, 125, 150, 200	90	11	11	112	125	82	95	6.6	9	25	108	30	55	60	80	25	45	M6 x 1 depth 9	1/8	26	12	82	48
25	75, 100, 125, 150, 200, 250, 300	100	14	13	134	150	92	108	9	9	30	130	35	65	70	100	35	54	M6 x 1 depth 13	1/8	31	13	100	57
32		120	14	16	134	150	102	118	9	9	35	135	40	73	80	106	35	60	M6 x 1 depth 13	1/8	38	16	114	65
40		140	17	19	170	186	134	150	9	12	45	170	50	93	95	134	50	75	M8 x 1.25 depth 16	1/8	47	20	138	84
50		170	23	21	190	210	140	160	11	12	50	194	55	103	115	152	56	90	M10 x 1.5 depth 21	1/4	58	25	164	94

Note) Rc, NPT and G ports can be selected.

Bore size (mm)	W	X	Z	Bore size (mm)	For lock type	
					HN*	HR*
20	40	39	157	20	37	25.3
25	46	46	175	25	40	28.3
32	52	46	201	32	43	31.3
40	62	56	238	40	52.5	38.3
50	75	67	285	50	58.5	44.5

Bore size (mm)	Rod end lock			Head end lock		
	Q*	R	Y*	Q	R*	Y*
20	38.5	12(14)	98(106)	12	11	95
25	39	12(14)	98(106)	12	11	95
32	40	12(14)	101(109)	12	11	97
40	41	12(15)	109(118)	13	11	111
50	47	14(16)	125(137)	14	16	128

Note) () : Denotes the dimensions for long stroke.

Long Stroke

Bore size (mm)	Stroke range (mm)
20	250 to 400
25	350 to 500
32	350 to 600
40	350 to 800
50	350 to 1000

Bracket Mounting Stroke

Bore size (mm)	Bracket mounting stroke
20	100 st or more
25	125 st or more
32	150 st or more
40	200 st or more
50	250 st or more

Dimensions

Front mounting flange type: **MGG□F**
 ø63 to ø100

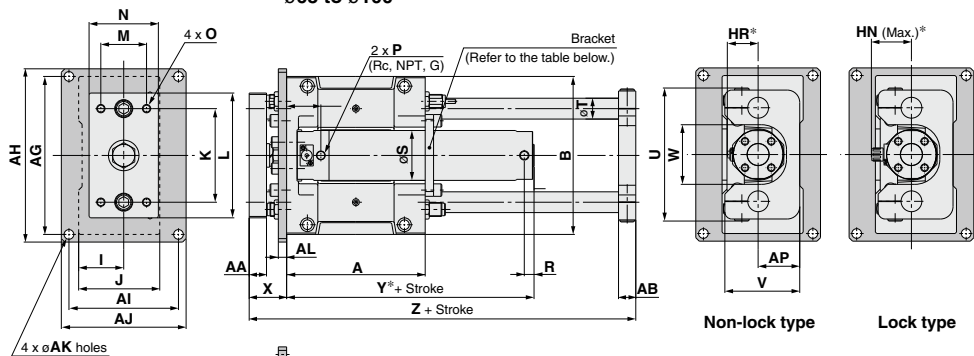

ø100 piston rod end connection

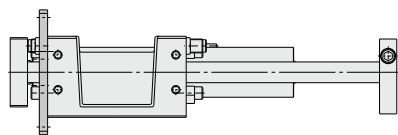

Rod end lock

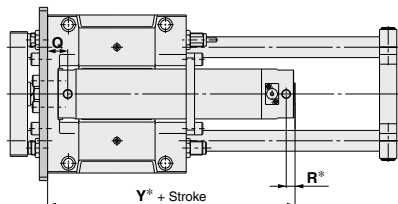

Head end lock

Dimensions not marked with an "*" are the same as standard.

Bore size (mm)	Stroke range (mm)	A	AA	AB	AG	AH	AI	AJ	AK	AL	AP	B	I	J	K	L	M	N	O	P*	S	T	U	V
63	75, 100, 125	200	25	25	228	250	158	180	14	12	60	228	65	117	135	180	66	100	M12 x 1.75 depth 23	1/4	72	30	192	108
80	150, 200	230	30	27	262	284	178	200	14	16	70	262	75	138	160	214	76	115	M12 x 1.75 depth 28	3/8	89	35	224	128
100	250, 300	280	32	30	300	326	200	226	16	16	80	304	85	153	190	245	80	125	M14 x 2 depth 30	1/2	110	40	262	143

Bore size (mm)	W	X	Z	Bore size (mm)	For lock type	
					HN*	HR*
63	86	54	308	63	59	45
80	104	66	355	80	68	53.5
100	128	66	410	100	79	64.5

Bore size (mm)	Rod end lock			Head end lock		
	Q*	R	Y*	Q	R*	Y*
63	63	14(16)	142(154)	29	15	147
80	82	19(23)	175(189)	40	17	182
100	85	19(23)	180(194)	40	23	188

Note) Rc, NPT and G ports can be selected.

Note) (): Denotes the dimensions for long stroke.

Long Stroke

Bore size (mm)	Stroke range (mm)
63	350 to 1100
80	350 to 1200
100	350 to 1300

Bracket Mounting Stroke

Bore size (mm)	Bracket mounting stroke
63	300 st or more
80	400 st or more
100	500 st or more

- MGGJ
- JMGP
- MGP
- MGPW
- MGQ
- MGG**
- MGC
- MGF
- MGT

- D-□
- X□

Auto Switch Mounting 1

Auto Switch Proper Mounting Position (Detection at Stroke End) and Its Mounting Height

D-M9□, M9□W
D-M9□A
D-A9□

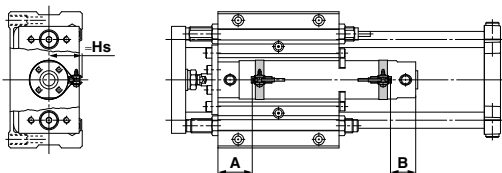

D-M9□V, M9□WV
D-M9□AV
D-A9□V

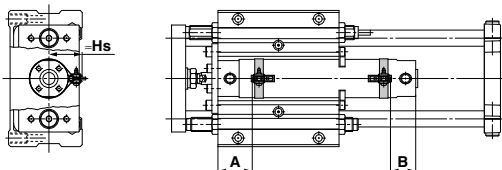

D-H7□, H7□W
D-H7NF, H7BA
D-H7C
D-C7□, C80
D-C73C, C80C

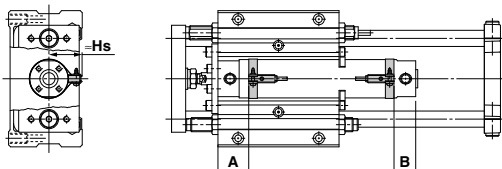

D-G5□, K59
D-G5□W, K59W
D-G59F, G5BA
D-G5NT
D-B5□, B64
D-B59W

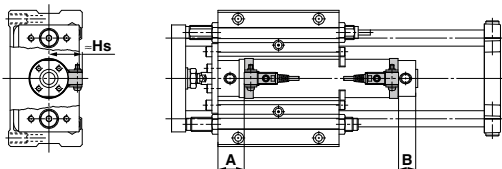

Auto Switch Proper Mounting Position (mm)

Auto switch model	D-A9□(V)		D-M9□(V) D-M9□W(V) D-M9□A(V)		D-C7□ D-C80 D-C73C D-C80C		D-B5□ D-B64		D-B59W		D-H7□ D-H7C D-H7NF D-H7□W D-H7BA		D-G59F D-G5□ D-K59 D-G5□W D-K59W D-G5NT D-G5BA	
	A	B	A	B	A	B	A	B	A	B	A	B	A	B
20	29	20 (28)	33	24 (32)	29.5	20.5 (28.5)	23.5	15.5 (22.5)	26.5	17.5 (25.5)	28.5	19.5 (27.5)	25	16 (24)
25	28.5	20.5 (28.5)	32.5	24.5 (32.5)	29	21 (29)	23	15 (23)	26	18 (26)	28	20 (28)	24.5	16.5 (24.5)
32	30	21 (29)	34	25 (33)	30.5	21.5 (29.5)	24.5	15.5 (23.5)	27.5	18.5 (26.5)	29.5	20.5 (28.5)	26	17 (25)
40	35	23 (32)	39	27 (36)	35.5	23.5 (32.5)	29.5	19 (26.5)	32	20.5 (29.5)	34.5	22.5 (31.5)	31	19 (28)
50	42	28 (40)	46	32 (36)	42.5	28.5 (40.5)	36.5	22.5 (34.5)	39.5	25.5 (37.5)	41.5	27.5 (39.5)	38	24 (36)
63	40.5	29.5 (41.5)	44.5	33.5 (45.5)	41	30 (42)	35	24 (36)	38	27 (39)	40	29 (41)	36.5	25.5 (37.5)
80	—	—	—	—	—	—	48	29 (43)	51	32 (46)	—	—	49.5	30.5 (44.5)
100	—	—	—	—	—	—	47	30 (44)	50	33 (47)	—	—	48.5	31.5 (45.5)

Auto Switch Mounting Height (mm)

Auto switch model	D-M9□(V) D-M9□W(V) D-M9□A(V) D-A9□(V)		D-C73C D-C80C	D-H7C D-G5□ D-G5□W D-K59 D-K59W D-G59F D-G5BA D-G5NT D-B5□ D-B59W D-B64	
	Hs	Hs		Hs	Hs
20	26.5	27	27.5	27.5	27.5
25	29	29.5	30	30	30
32	32.5	33	33.5	33.5	33.5
40	37	37.5	38	38	38
50	42.5	43	43.5	43.5	43.5
63	49.5	50	50.5	50.5	50.5
80	—	—	59	59	59
100	—	—	69.5	69.5	69.5

(): Set values for long stroke, double rod

Note 1) Adjust the auto switch after confirming the operating conditions in the actual setting.

Note 2) The D-H7C cannot be mounted on ø80 and ø100.

**Auto Switch Proper Mounting Position (Detection at Stroke End)
and Its Mounting Height/End Lock Type: With Head End Lock**

D-M9□, M9□W
D-M9□A
D-A9□

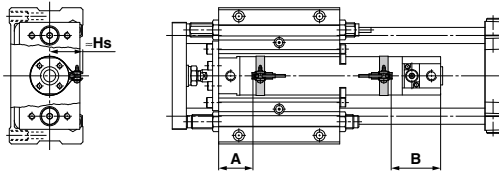

D-M9□V, M9□WV
D-M9□AV
D-A9□V

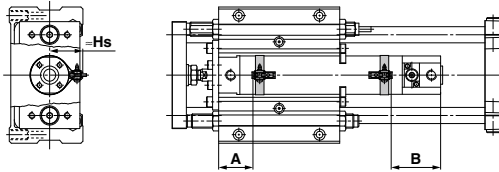

D-H7□, H7□W
D-H7NF, H7BA
D-H7C
D-C7□, C80
D-C73C, C80C

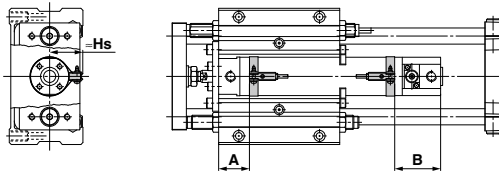

D-G5□, K59
D-G5□W, K59W
D-G59F, G5BA
D-G5NT
D-B5□, B64
D-B59W

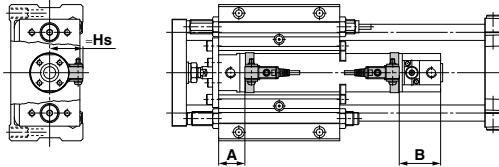

Auto Switch Proper Mounting Position

Auto switch model	(mm)													
	Note 2) D-A9□(V)		Note 2) D-M9□(V) D-M9□W(V) D-M9□A(V)		D-C7□ D-C80 D-C73C D-C80C		D-B5□ D-B64		D-B59W		D-H7□ D-H7C D-H7NF D-H7□W D-H7BA		D-G59F D-G5□ D-K59 D-G5□W D-K59W D-G59W D-G5NT D-G5BA	
	A	B	A	B	A	B	A	B	A	B	A	B	A	B
20	29	44	33	48	29.5	44.5	23.5	38.5	26.5	41.5	28.5	43.5	25	40
25	29	44	33	48	29.5	44.5	23.5	38.5	26.5	41.5	28.5	43.5	25	40
32	30	45	34	49	30.5	45.5	24.5	39.5	27.5	42.5	29.5	44.5	26	41
40	35	54	39	58	35.5	54.5	29.5	48.5	32	51.5	34.5	53.5	31	50
50	42	64	46	68	42.5	64.5	36.5	58.5	39.5	61.5	41.5	63.5	38	60
63	42	68	46	72	42.5	68.5	36.5	62.5	39.5	65.5	41.5	67.5	38	64
80	—	—	—	—	—	—	46.5	81.5	49.5	84.5	—	—	48	83
100	—	—	—	—	—	—	46.5	87.5	49.5	90.5	—	—	48	89

Auto Switch Mounting Height

Auto switch model	(mm)				
	Note 2) D-M9□(V) D-M9□W(V) D-M9□A(V) D-A9□(V)		D-H7□ D-H7□W D-H7NF D-H7BA D-C7□ D-C80	D-C73C D-C80C	D-H7C ^{Note 3)} D-G5□ D-G5□W D-K59 D-K59W D-G59F D-G5BA D-G5NT D-B5□ D-B59W D-B64
	Hs	Hs	Hs	Hs	
20	26.5	26.5	27	27.5	
25	29	29	29.5	30	
32	32.5	32.5	33	33.5	
40	37	37	37.5	38	
50	42.5	42.5	43	43.5	
63	49.5	49.5	50	50.5	
80	—	—	—	59	
100	—	—	—	69.5	

Note 1) Adjust the auto switch after confirming the operating conditions in the actual setting.
Note 2) Values when "C" is specified at the end of the cylinder model number
Note 3) The D-H7C cannot be mounted on ø80 and ø100.

- MGJ
- JMP
- MGP
- MGPW
- MGO
- MGG
- MGC
- MGF
- MGZ
- MGT

- D-□
- X□

Auto Switch Mounting 2

Auto Switch Proper Mounting Position (Detection at Stroke End) and Its Mounting Height/End Lock Type: With Rod End Lock

D-M9□, M9□W
D-M9□A
D-A9□

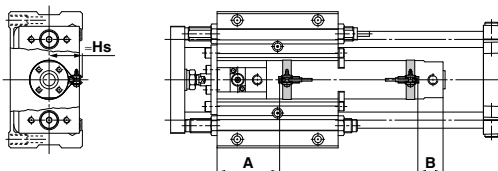

D-M9□V, M9□WV
D-M9□AV
D-A9□V

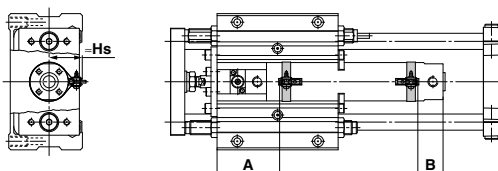

D-H7□, H7□W
D-H7NF, H7BA
D-H7C
D-C7□, C80
D-C73C, C80C

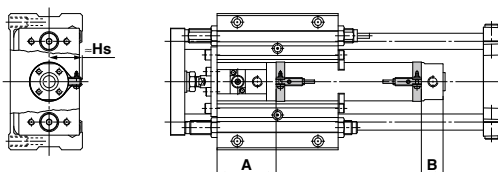

D-G5□, K59
D-G5□W, K59W
D-G59F, G5BA
D-G5NT
D-B5□, B64
D-B59W

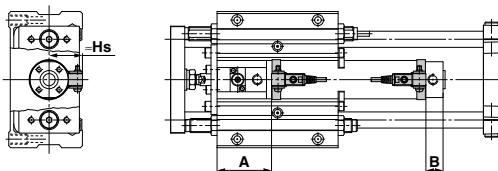

Auto Switch Proper Mounting Position

(mm)

Auto switch model	Note 2) D-A9□(V)		Note 2) D-M9□(V) D-M9□W(V) D-M9□A(V)		D-C7□ D-C80 D-C73C D-C80C		D-B5□ D-B64		D-B59W		D-H7□ D-H7C D-H7NF D-H7□W D-H7BA		D-G59F D-G5□ D-K59 D-G5□W D-K59W D-G5NT D-G5BA		
	A	B	A	B	A	B	A	B	A	B	A	B	A	B	B
20	56 (28)	20 (20)	60	24 (32)	56.5	20.5 (28.5)	60.5	14.5 (22.5)	53.5	17.5 (25.5)	55.5	19.5 (27.5)	52	16 (24)	
25	56 (28)	21 (21)	60	24 (32)	56.5	20.5 (28.5)	50.5	14.5 (22.5)	53.5	17.5 (25.5)	55.5	19.5 (27.5)	52	16 (24)	
32	58 (29)	21 (29)	62	25 (33)	58.5	21.5 (29.5)	52.5	15.5 (23.5)	55.5	18.5 (26.5)	57.5	20.5 (28.5)	54	17 (25)	
40	64 (32)	23 (32)	68	27 (36)	64.5	23.5 (32.5)	58.5	17.5 (26.5)	61	20.5 (29.5)	63.5	22.5 (31.5)	60	19 (28)	
50	75 (40)	28 (40)	79	32 (44)	75.5	28.5 (40.5)	69.5	22.5 (34.5)	72.5	25.5 (37.5)	74.5	27.5 (39.5)	71	24 (36)	
63	77 (40)	28 (40)	81	32 (44)	77.5	28.5 (40.5)	71.5	22.5 (34.5)	74.5	25.5 (37.5)	76.5	27.5 (39.5)	73	24 (36)	
80	—	—	—	—	—	—	90.5	30.5 (44.5)	93.5	33.5 (47.5)	—	—	92	32 (46)	
100	—	—	—	—	—	—	95.5	30.5 (44.5)	98.5	33.5 (47.5)	—	—	97	32 (46)	

() : Set values for long stroke, double rod

Note 1) Adjust the auto switch after confirming the operating conditions in the actual setting.

Note 2) Values when "C" is specified at the end of the cylinder model number

Note 3) The D-H7C cannot be mounted on ø80 and ø100.

Auto Switch Mounting Height

(mm)

Auto switch model	Note 2) D-M9□(V) D-M9□W(V) D-M9□A(V) D-A9□(V)		D-H7□ D-H7□W D-H7NF D-H7BA D-C7□ D-C80		D-C73C D-C80C		D-H7C ^{Note 3)} D-G5□ D-G5□W D-K59 D-K59W D-G59F D-G5BA D-G5NT D-B5□ D-B59W D-B64	
	Hs	Hs	Hs	Hs	Hs	Hs	Hs	
20	26.5	26.5	27	27.5				
25	29	29	29.5	30				
32	32.5	32.5	33	33.5				
40	37	37	37.5	38				
50	42.5	42.5	43	43.5				
63	49.5	49.5	50	50.5				
80	—	—	—	59				
100	—	—	—	69.5				

Minimum Auto Switch Mounting Stroke

Auto switch model	n: No. of auto switches (mm)		
	No. of auto switches mounted		
	1 pc.	2 pcs. Same surface	"n" pcs. Same surface
D-M9□	5	40 <small>Note 1)</small>	55 + 35 (n-2) (n = 2, 3, 4, 5...)
D-M9□W	10	40 <small>Note 1)</small>	55 + 35 (n-2) (n = 2, 3, 4, 5...)
D-M9□A	10	40 <small>Note 1)</small>	60 + 35 (n-2) (n = 2, 3, 4, 5...)
D-A9□	5	30 <small>Note 1)</small>	50 + 35 (n-2) (n = 2, 3, 4, 5...)
D-M9□V	5	35	35 + 35 (n-2) (n = 2, 3, 4, 5...)
D-A9□V	5	25	25 + 35 (n-2) (n = 2, 3, 4, 5...)
D-M9□WV D-M9□AV	10	35	35 + 35 (n-2) (n = 2, 3, 4, 5...)
D-C7□ D-C80	5	50	50 + 45(n-2) (n = 2, 3, 4, 5...)
D-H7□ D-H7□W D-H7BA/H7NF	10	60	60 + 45 (n-2) (n = 2, 3, 4, 5...)
D-C73C/C80C D-H7C	5	65	65 + 50 (n-2) (n = 2, 3, 4, 5...)
D-B5□/B64 D-G5□/K59□	5	75	75 + 55 (n-2) (n = 2, 3, 4, 5...)
D-B59W	10		

Note 1) Auto switch mounting

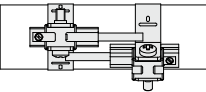
Auto switch model	With 2 auto switches	
	Same surface	
	 <p>The auto switch is mounted by slightly displacing it in a direction (cylinder tube circumferential exterior) so that the auto switch and lead wire do not interfere with each other.</p>	
D-M9□ D-M9□W	Less than 55 stroke <small>Note 2)</small>	
D-M9□A	Less than 60 stroke <small>Note 2)</small>	
D-A9□	Less than 50 stroke <small>Note 2)</small>	

Note 2) Minimum stroke for mounting auto switches in the other mounting types mentioned in note 1.

Operating Range

Auto switch model	Bore size (mm)							
	20	25	32	40	50	63	80	100
D-M9□(V)/M9□W(V) D-M9□A	4.5	5	4.5	5.5	5	5.5	—	—
D-A9□	7	6	8	8	8	9	—	—
D-C7□/C80 D-C73C/C80C	8	10	9	10	10	11	—	—
D-B5□/B64	8	10	9	10	10	11	11	11
D-B59W	13	13	14	14	14	17	16	18

Auto switch model	Bore size (mm)								(mm)
	20	25	32	40	50	63	80	100	
D-H7□/H7□W D-H7BA/H7NF	4	4	4.5	5	6	6.5	—	—	
D-H7C	7	8.5	9	10	9.5	10.5	—	—	
D-G5□/K59 D-G5□W/K59W D-G5NT/G5BA	4	4	4.5	5	6	6.5	6.5	7	
D-G59F	5	5	5.5	6	7	7.5	7.5	8	

* Since this is a guideline including hysteresis, not meant to be guaranteed. (Assuming approximately ±30% dispersion) There may be the case to change substantially depending on an ambient environment.

MGGJ

JMGP

MGP

MGPW

MGQ

MGG

MGC

MGF

MGZ

MGT

D-□

-X□

Auto Switch Mounting 3

Auto Switch Mounting Bracket: Part No.

Auto switch model	Bore size (mm)							80	100
	20	25	32	40	50	63	63		
D-M9□(V) D-M9□W(V) D-A9□(V)	BMA3-020 (A set of a, b, c, d)	BMA3-025 (A set of a, b, c, d)	BMA3-032 (A set of a, b, c, d)	BMA3-040 (A set of a, b, c, d)	BMA3-050 (A set of a, b, c, d)	BMA3-063 (A set of a, b, c, d)	—	—	
D-M9□A(V) <i>Note 2)</i>	BMA3-020S (A set of b, c, d, e)	BMA3-025S (A set of b, c, d, e)	BMA3-032S (A set of b, c, d, e)	BMA3-040S (A set of b, c, d, e)	BMA3-050S (A set of b, c, d, e)	BMA3-063S (A set of b, c, d, e)	—	—	

a Switch bracket (Resin)
Transparent (Nylon) *Note 1)*
White (PBT)

b Switch holder

c Auto switch mounting band

d Auto switch mounting screw

Auto switch

* Band (c) is mounted so that the projected part is on the internal side (contact side with the tube).

D-C7□/C80 D-C73C/C80C D-H7□ D-H7□W D-H7NF	BMA2-020A (A set of band and screw)	BMA2-025A (A set of band and screw)	BMA2-032A (A set of band and screw)	BMA2-040A (A set of band and screw)	BMA2-050A (A set of band and screw)	BMA2-063A (A set of band and screw)	—	—
D-H7BA	BMA2-020AS (A set of band and screw)	BMA2-025AS (A set of band and screw)	BMA2-032AS (A set of band and screw)	BMA2-040AS (A set of band and screw)	BMA2-050AS (A set of band and screw)	BMA2-063AS (A set of band and screw)	—	—
D-B5□/B64 D-B59W D-G5□/K59 D-G5BA/G59F D-G5NT	BA-01 (A set of band and screw)	BA-02 (A set of band and screw)	BA-32 (A set of band and screw)	BA-04 (A set of band and screw)	BA-05 (A set of band and screw)	BA-06 (A set of band and screw)	BA-08 (A set of band and screw)	BA-10 (A set of band and screw)

Note 1) Since the switch bracket (made from nylon) are affected in an environment where alcohol, chloroform, methylamines, hydrochloric acid or sulfuric acid is splashed over, so it cannot be used. Please contact SMC regarding other chemicals.

Note 2) For the D-M9□A (V) type auto switch, do not install the switch bracket on the indicator light.

Band Mounting Brackets Set Part No.

Set part no.	Contents
BMA2-□□□A (S) * S: Stainless steel screw	- Auto switch mounting band (c) - Auto switch mounting screw (d)
BJ4-1	- Switch bracket (White/PBT) (e) - Switch holder (b)
BJ5-1	- Switch bracket (Transparent/Nylon) (a) - Switch holder (b)

[Stainless Steel Mounting Screw]

The following stainless steel mounting screw kit is available. Use it in accordance with the operating environment.

(Since the auto switch mounting bracket is not included, order it separately.)
BBA3: D-B5/B6/G5/K5 types

Note 3) For details about the BBA3, refer to page 1225.

When the D-G5BA type auto switch is shipped independently, the BBA3 is attached.

Besides the models listed in How to Order, the following auto switches are applicable.
Refer to pages 1119 to 1245 for detailed specifications.

Type	Model	Electrical entry	Features	Applicable bore size
Solid state auto switch	D-H7A1, H7A2, H7B	Grommet (In-line)	—	ø20 to ø63
	D-H7NW, H7PW, H7BW		Diagnostic indication (2-color indicator)	
	D-H7BA		Water resistant (2-color indicator)	
	D-G5NT		With timer	
Reed auto switch	D-B53	Grommet (In-line)	—	ø20 to ø100
	D-C73, C76		—	
	D-C80		Without indicator light	ø20 to ø63

* For solid state auto switches, auto switches with a pre-wired connector are also available. Refer to pages 1192 and 1193 for details.

* Normally closed (NC = b contact) solid state auto switches (D-F9G/F9H types) are also available. Refer to page 1137 for details.

MGG Series

Made to Order: Individual Specifications 1

Please contact SMC for detailed dimensions, specifications and lead times.



1 With Piping Ports for Grease

Symbol
-X440

This type is equipped with Rc 1/8 piping ports for grease on both sides of the guide body.

How to Order

MGG Standard model no. **-X440**

With piping port for grease ↓

Applicable series	MGG	MGC
Bore size (mm)	20, 25, 32, 40, 50 63, 80, 100	20, 25, 32, 40, 50
Fluid	Air	
Minimum operating pressure	0.15 MPa (Horizontal, No load)	
Piston speed	50 to 1000 mm/s	50 to 750 mm/s
Auto switch	Mountable	
Specifications other than above	Same as the standard type	

Dimensions (Dimensions other than those below are the same as the standard type.)

MGG series

ø20 to ø50

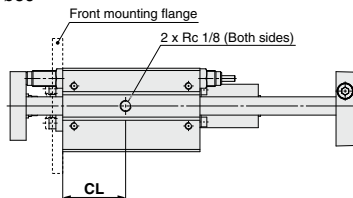

ø63 to ø100

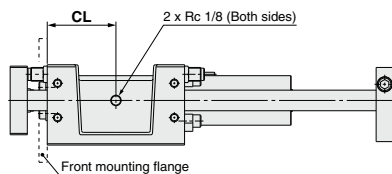

(mm)	
Series	MGG
Bore size (mm)	CL
20	40
25	45
32	55
40	65
50	80
63	100
80	115
100	140

* The standard grease supply port has a hexagon socket head set screw.

MGG

JMGP

MGP

MGPW

MGQ

MGG

MGC

MGF

MGZ

MGT

D-□

-X□

1 With Piping Ports for Grease (Water resistant type)

Symbol
-X440

Type with piping port (Rc 1/8) for grease on both sides of water resistant cylinder guide body.

How to Order

MGGM [Mounting type] [Bore size] [Port thread type] **R** — Stroke — **M9NA** [Suffix for auto switch] — **X440**

- Slide bearing
- Water resistant cylinder
 - R** NBR seal (Nitrile rubber)
 - V** FKM seal (Fluororubber)
- With piping ports for grease
 - Water resistant 2-color indicator
 - Solid state auto switch

Specifications

Applicable series	MGGM
Bore size (mm)	32, 40, 50, 63, 80, 100
Fluid	Air
Minimum operating pressure	0.15 MPa (Horizontal, No-load)
Piston speed	50 to 1000 mm/s
Auto switch	Available for mounting (Water resistant type)
Bearing type	Slide bearing
Specifications other than above	Same as standard type.

* RBL (coolant resistant) type shock absorbers are used.

Dimensions (Dimensions other than those below are the same as the standard type.)

ø32 to ø50

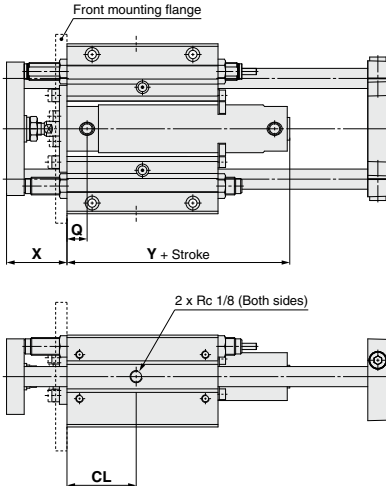

ø63 to ø100

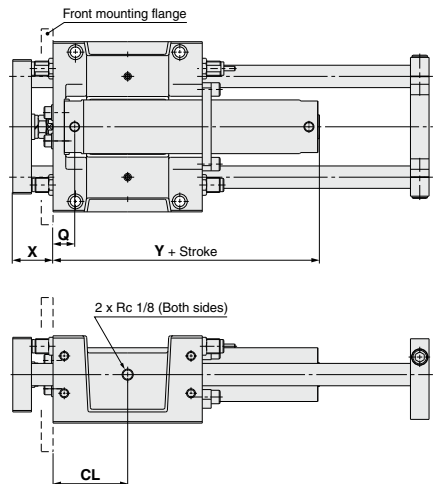

Bore size (mm)	Q			X	Y	CL
	Rc	NPT	G			
32	16	14.5	48	77 (85)	55	
40	17	17	58	84 (93)	65	
50	19	19	69	97 (109)	80	
63	34	34	56	112 (124)	100	
80	46	43.5	68	137 (151)	115	
100	47	44.5	68	138 (152)	140	

* () : Denotes the dimensions for long stroke.

* The standard grease supply port has a hexagon socket head set screw.

2 Auto Switch Rail Mounting Type With Piping Ports for Grease

Symbol
-X772

Cylinder with auto switch rail mounting with piping ports (Rc 1/8) for grease on both sides of guide body.

How to Order

MGG Bearing type Mounting type Bore size — Stroke — Auto switch — **X772**

● Auto switch rail mounting type
With piping ports for grease

Dimensions (Dimensions other than those below are the same as the standard type.)

ø20 to ø50

ø63 to ø100

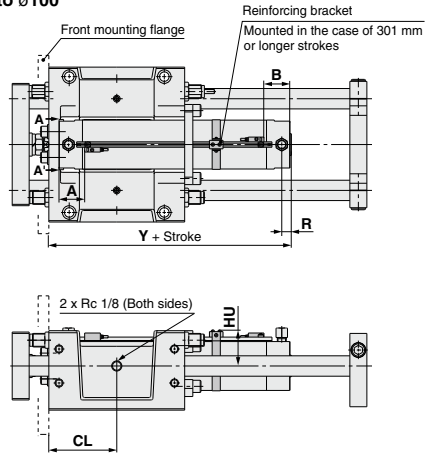
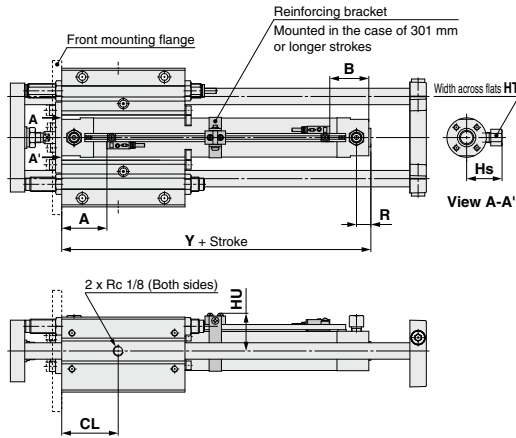

Bore size (mm)	R	Y	CL	HS	HT	HU
20	14	99	40	28.5	14	30.7
25	14	99	45	31	14	33.2
32	14	101	55	34.5	14	36.5
40	15	109	65	39	14	41
50	16	124	80	49.5	17	46.2
63	16	139	100	56.5	17	53.2
80	23	165	115	75.5	23	62.2
100	23	165	140	86	26	72.7

* The standard grease supply port has a hexagon socket head set screw.

Proper Auto Switch Mounting Position/Applicable Cylinder Series: MGG/MGC (mm)

Applicable bore size (mm)	D-M9□/M9□V		D-F7□/F79F/F7□V		D-F79/J79C		D-F7□W/M9□WV		D-F7BA/F7BAV		D-A7□/D-A80		D-A79W	
	A	B	A	B	A	B	A	B	A	B	A	B	A	B
20	45.5	39.5	43	37	48	42	42.5	36.5	40	34				
25	45.5	39.5	43	37	48	42	42.5	36.5	40	34				
32	46.5	40.5	44	38	49	43	43.5	37.5	41	35				
40	51.5	43.5	49	41	54	46	48.5	40.5	46	38				
50	58.5	51.5	56	49	61	54	55.5	48.5	53	46				
63	58.5	51.5	56	49	61	54	55.5	48.5	53	46				
80	68.5	61.5	66	59	71	64	65.5	58.5	63	56				
100	68.5	61.5	66	59	71	64	65.5	58.5	63	56				

Auto Switch Mounting Height (mm)

D-M9□/M9□V	D-M9□W/M9□WV	D-M9□A/M9□AV	D-F7□/F79F	D-F7□V	D-F7□WV	D-F7BAV	D-J79C	D-A7□/D-A80	D-A73C/D-A80C	D-A79W
Hs	Hs	Hs	Hs	Hs	Hs	Hs	Hs	Hs	Hs	Hs
26.5	29	31	26.5	32.5	30					
29	31.5	33.5	29	35	32.5					
32.5	34.5	36.5	32	38.5	35.5					
37	39	41	36.5	43	40					
42	44.5	46.5	42	48	45.5					
49	51.5	53.5	49	55	52.5					
58	60.5	62.5	58	64	61.5					
69	71	73	68.5	74.5	72					

Note 1) Adjust the auto switch after confirming the operating conditions in the actual setting.

Note 2) Refer to the MGG and MGC series standard types for dimensions other than the auto switch mounting position and mounting height.

- MGG
- JMGF
- MGP
- MGPW
- MGO
- MGG
- MGC
- MGF
- MGZ
- MGT

- D-□
- X□



Please contact SMC for detailed dimensions, specifications and lead times.

2 Auto Switch Rail Mounting Type/With Piping Ports for Grease (Water resistant type) Symbol **-X772**

Type with piping port (Rc 1/8) for grease on both sides of water resistant cylinder guide body.

How to Order

MGG M Mounting type Bore size **R** Stroke M9NA Suffix for auto switch **-X772**

- Slide bearing
- Water resistant cylinder
 - R** NBR seals (Nitrile rubber)
 - V** FKM seals (Fluororubber)
- Water resistant 2-color indicator
Solid state auto switch
- Auto switch rail mounting with piping ports for grease

Specifications

Applicable series	MGGM
Bore size (mm)	32, 40, 50, 63, 80, 100
Fluid	Air
Minimum operating pressure	0.15 MPa (Horizontal, No-load)
Piston speed	50 to 1000 mm/s
Auto switch	Available for mounting (Water resistant type)
Bearing type	Slide bearing
Other specifications	Same as standard type.

* RBL (coolant resistant) type shock absorbers are used.

Dimensions (Dimensions other than those below are the same as the standard type.)

ø32 to ø50

ø63 to ø100

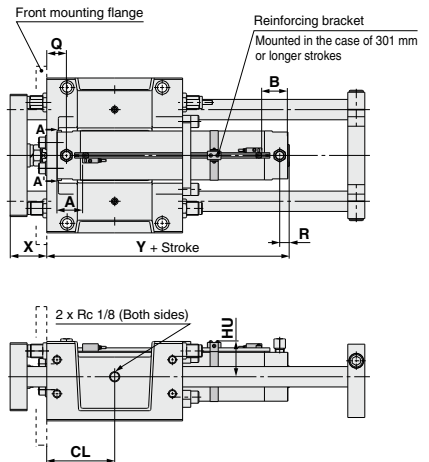
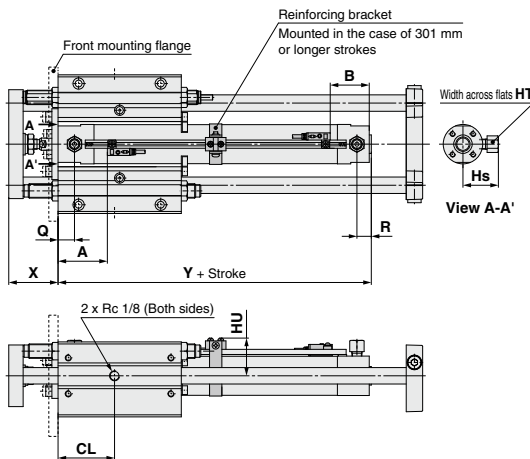

Bore size (mm)	(mm)							
	Q	R	X	Y	CL	HS	HT	HU
32	16	14	48	105	55	34.5	14	36.5
40	17	15	58	113	65	39	14	41
50	19	16	69	129	80	49.5	17	46.2
63	34	16	56	144	100	56.5	17	53.2
80	46	23	68	171	115	75.5	23	62.2
100	47	23	68	172	140	86	26	72.2

* The standard grease supply port has a hexagon socket head set screw.

Proper Auto Switch Mounting Position (mm)

Applicable bore size (mm)	Auto switch model	D-F7BAL/F7BAVL	
		A	B
32	50	50	38
40	55	55	41
50	63	63	49
63	63	63	49
80	74	74	59
100	75	75	59

Auto Switch Mounting Height (mm)

Applicable bore size (mm)	Auto switch model	D-F7BAL	D-F7BAVL
		Hs	Hs
32	32.5	32.5	34.5
40	37	37	39
50	42	42	44.5
63	49	49	51.5
80	58	58	60.5
100	69	69	71

Note) Adjust the auto switch after confirming the operating conditions in the actual setting.



MGG Series

Specific Product Precautions 1

Be sure to read this before handling the products.

Refer to back page 50 for Safety Instructions and pages 3 to 12 for Actuator and Auto Switch Precautions.

Mounting and Adjustment

Warning

1. Install a protective cover.

Since the rear plate moves back and forth during mounting, handling and operation, be careful that hands, etc., do not get caught between the cylinder and the rear plate.

When you are going to fit this product to the outside of your equipment, take preventative measures such as installing a protective cover.

Protective cover installation example

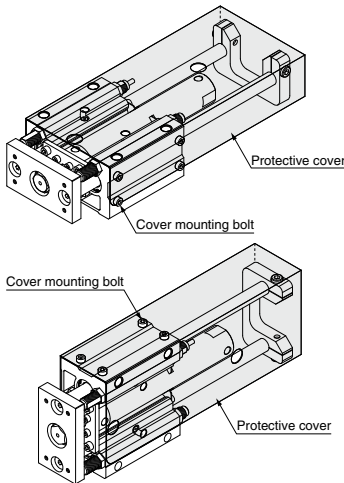

Handling on Shock Absorber

Caution

1. Be sure to confirm by referring to the shock absorber (RB series, Best Pneumatics No. 2-3) for details.

Caution

1. Use caution that no scratch or dent will be given to the slide part of the guide rod.

Because the outer circumference of the guide rod is manufactured with precise tolerances, even a slight deformation, scratch, or gouge can lead to faulty operation or reduced durability.

2. When mounting the guide body, use a mounting surface having a high degree of flatness.

If twisting or bending occurs in the guide rods, this can cause problems such as a large increase in operating resistance and reduced performance due to premature wear of the bearings.

3. Mount in locations where maintenance will be easy.

Ensure enough clearance around the cylinder to allow for unobstructed maintenance and inspection work.

4. Extension stroke adjustment

To adjust the extension stroke by moving the rear plate, loosen the hexagon socket head screws on the left and right sides of the plate, move the rear plate to the desired stroke position in proximity to the guide body, and retighten the hexagon socket head screws on the left and right.

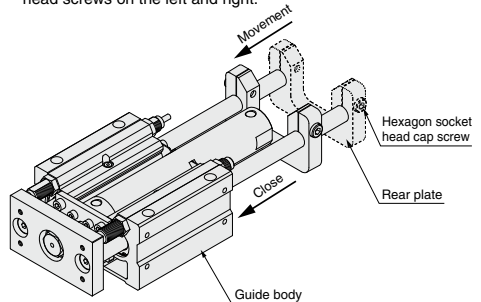

5. Lubrication of bearings

Lubricate from the grease nipple so that there is no contamination from foreign matter.

In addition, use good quality no. 2 lithium soap base grease.

6. Mounting orientation

If the guide body is mounted so that it is inclined more than 90°, the rear plate may interfere with the basic cylinder head end due to the deflection of guide rods. Please consult with SMC.

7. Fixing of base cylinder

When the product is mounted and operated in a location with low rigidity, bending moment may be applied to the base cylinder by vibrations generated at the stroke end, causing damage to the cylinder. In such cases, install a support bracket to suppress the vibration of the body of the base cylinder or reduce the piston speed until the body does not vibrate at the stroke end.

MGG

JMGP

MGP

MGPW

MGQ

MGG

MGC

MGF

MGZ

MGT

D-□

-X□



MGG Series

Specific Product Precautions 2

Be sure to read this before handling the products.

Refer to back page 50 for Safety Instructions and pages 3 to 12 for Actuator and Auto Switch Precautions.

With End Lock

Use the Recommended Pneumatic Circuit

⚠ Caution

- This is necessary for proper operation and release of the lock.

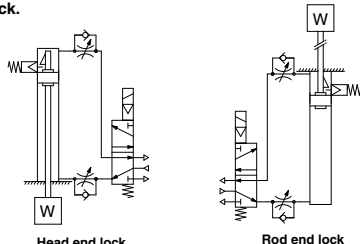

Head end lock

Rod end lock

Operating Precautions

⚠ Caution

- Do not use 3 position solenoid valves.**
Avoid use in combination with 3 position solenoid valves (especially closed center metal seal types). If pressure is trapped in the port on the lock mechanism side, the cylinder cannot be locked. Furthermore, even after being locked, the lock may be released after some time, due to air leaking from the solenoid valve and entering the cylinder.
- Back pressure is required when releasing the lock.**
Before starting operation, be sure to control the system so that air is supplied to the side without the lock mechanism as shown in the figure above. There is a possibility that the lock may not be released. (→ Refer to the section (right side) on releasing the lock.)
- Release the lock when mounting or adjusting the cylinder.**
If mounting or other work is performed when the cylinder is locked, the lock unit may be damaged.
- Operate with a load ratio of 50% or less.**
If the load ratio exceeds 50%, this may cause problems such as failure of the lock to release, or damage to the lock unit.
- Do not operate multiple cylinders in synchronization.**
Avoid applications in which two or more end lock cylinders are synchronized to move one workpiece, as one of the cylinder locks may not be able to release when required.
- Use a speed controller with meter-out control.**
Lock cannot be released occasionally by meter-in control.
- Be sure to operate completely to the cylinder stroke end on the side with the lock.**
If the cylinder piston does not reach the end of the stroke, locking and unlocking may not be possible. Therefore, do not adjust the stroke with the adjustment bolts or shock absorbers.
- Do not use an air cylinder as an air-hydro cylinder. This will cause leakage of hydraulic fluid.**
- Adjust an auto switch's position so that it operates for movement to both the stroke end and backlash (2 mm) positions.**
When a 2-color indicator switch is adjusted for green indication at the stroke end, it may change to red for the backlash return, but this is not abnormal.

⚠ Warning

- Operate within the specified cylinder speed.**
Otherwise, cylinder and seal damage may occur.

Operating Pressure

⚠ Caution

- Use air pressure of at least 0.15 MPa for the port on the lock mechanism side. This is necessary to release the lock.

Exhaust Speed

⚠ Caution

- Locking will occur automatically if the pressure applied to the port on the lock mechanism side falls to 0.05 MPa or less. In cases where the piping on the lock mechanism side is long and thin, or the speed controller is separated at some distance from the cylinder port, the exhaust speed will be reduced. Take note that some time may be required for the lock to engage. In addition, clogging of a silencer mounted on the solenoid valve exhaust port can produce the same effect.

Releasing the Lock

⚠ Warning

- Before releasing the lock, be sure to supply air to the side without the lock mechanism, so that there is no load applied to the lock mechanism when it is released. (Refer to the recommended pneumatic circuits.) If the lock is released when the port on the other side is in an exhaust state, and with a load applied to the lock unit, the lock unit may be subjected to an excessive force and be damaged. Furthermore, sudden movement of the piston rod is very dangerous.

Manual Release

⚠ Caution

1. Manual release (Non-lock type)

Insert the accessory bolt from the top of the rubber cap (it is not necessary to remove the rubber cap), and after screwing it into the lock piston, pull it to release the lock. If you stop pulling the bolt, the lock will return to an operational state.

Thread sizes, pulling forces and strokes are as shown below.

Bore size (mm)	Thread size	Pulling force (N)	Stroke (mm)
20, 25, 32	M2.5 x 0.45 x 25 L or more	4.9	2
40, 50, 63	M3 x 0.5 x 30 L or more	10	3
80, 100	M5 x 0.8 x 40 L or more	24.5	3

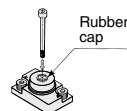

Remove the bolt for normal operation.
It can cause lock malfunction or faulty release.

2. Manual release, Lock type

While pushing the M/O knob, turn it 90° counterclockwise. The lock is released (and remains in a released state) by aligning the ▲ mark on the cap with the ▼ OFF mark on the M/O knob. When locking is desired, turn M/O button clockwise 90° while pushing fully, correspond ▲ on cap and ▼ ON mark on M/O button. The correct position is confirmed by a click sound "click". If not confirmed, locking is not done.

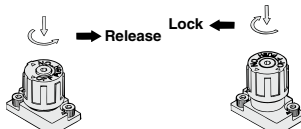

Locked condition

Released condition