

CXWM/CXWL Series

Prior to Use

1. Changing from the non-auto switch specifications to the auto switch specifications
2. Changing mounting type of the auto switch specifications

CXW^M Series

1. In CXW^M series, to change from the specification without auto switch to the plate mounting type with auto switch or to the housing mounting type with auto switch, refer to tables (3) and (4) before ordering.



2. In CXW^M series, to change from the plate mounting type with an auto switch to the housing mounting type with an auto switch or vice versa, refer to tables (3) and (4) before ordering.



Table (3) Plate Mounting Type with Auto Switch
(CDPXW^M_L□□□) Component Parts for Mounting Switches and No. of Component Parts

Component parts	Material	ø10	ø16	ø20	ø25	ø32
		Assembly model no. for mounting switch ⁽³⁾				
		CDPXW ^M _L 10S-□□	CDPXW ^M _L 16S-□□	CDPXW ^M _L 20S-□□	CDPXW ^M _L 25S-□□	CDPXW ^M _L 32S-□□
Switch mounting block	Aluminum alloy	1	1	1	1	1
Block mounting screw	Chrome steel/Nickel plated	2	2	2	2	2
Switch mounting screw	Chrome steel/Nickel plated	2	2	2	2	2
Hexagon nut	Carbon steel/Nickel plated	2	2	2	2	2
Magnet	—	1 (2) ⁽²⁾	—	—	—	—
Socket	Brass/Electroless nickel plated	2	—	—	—	—
Plug (M-5P)	Brass/Electroless nickel plated	2	2	2	—	—

Note 1) "□" mark indicates strokes.

Note 2) In the case of ø10, the 25 mm stroke has two magnets that are bonded in the holes on the side of the housing. Those with strokes of 50 mm to 100 mm have one magnet. Those with other bore sizes have a built-in magnet in their housings.

Note 3) For the assembly model no. for mounting switch, order with CDPXWM□□□ for CXWM series and order with CDPXWL□□□ for CXWL series respectively.

Table (4) Housing Mounting Type with Auto Switch
(CDBXW^M_L□□□) Component Parts for Mounting Switches and No. of Component Parts

Component parts	Material	ø10	ø16	ø20	ø25	ø32
		Assembly model no. for mounting switch				
		CDBXW ^M _L 10M-□□	CDBXW ^M _L 16M-□□	CDBXW ^M _L 20M-□□	CDBXW ^M _L 25M-□□	CDBXW ^M _L 32M-□□
Magnet mounting block assembly	Aluminum alloy	1	1	1	1	1
Switch mounting rail	Aluminum alloy	—	1	1	1	1
Spacer	Aluminum alloy/Anodized	2	—	—	—	—
Block mounting screw	Chrome steel/Nickel plated	2	2	2	2	2
Screw for mounting rail	Chrome steel/Nickel plated	—	2	2	2	2
Switch mounting screw	Chrome steel/Nickel plated	2	2	2	2	2
Hexagon nut	Carbon steel/Nickel plated	2	2	2	2	2
Hexagon socket head plug	Chrome steel/Nickel plated	2	2	2	—	—

Note 1) "□" mark indicates strokes.

Note 2) In the case of ø10, CDPXW^M10□ can NOT be changed to CDBXW^M10□. (CXW^M10□ can be changed to CDBXW^M10□)

Note 3) For the assembly model no. for mounting switch, order with CDBXWM□□□ for CXWM series and order with CDBXWL□□□ for CXWL series respectively.

Slide Unit: Built-in Shock Absorber Slide Bearing Type

CXWM Series

ø10, ø16, ø20, ø25, ø32

How to Order

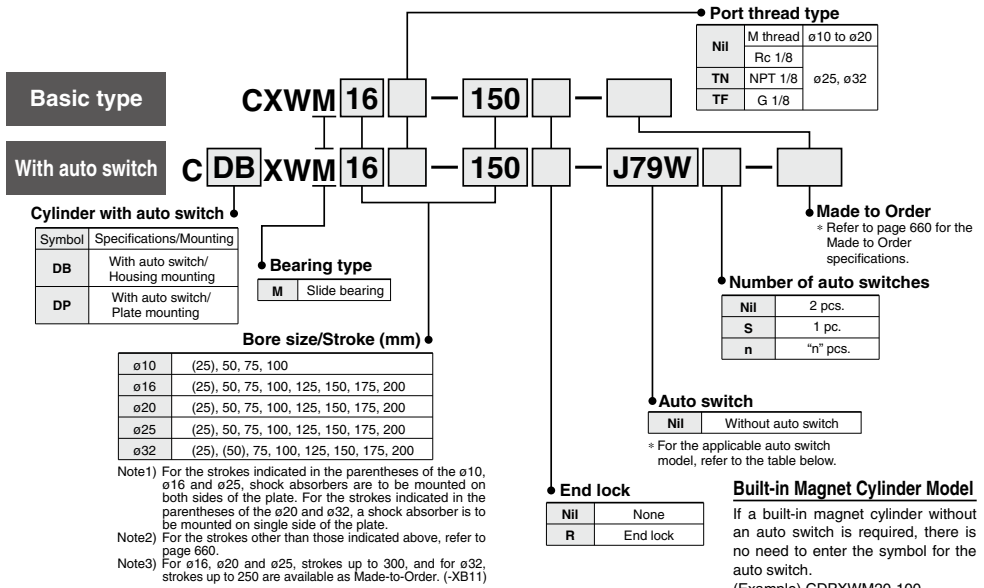

Applicable Auto Switches

Refer to pages 1119 to 1245 for further information on auto switches.

Type	Special function	Electrical entry	Indicator light	Wiring (Output)	Load voltage		Rail mounting		Applicable cylinder size		Lead wire length (m) *				Pre-wired connector	Applicable load							
					DC	AC	Perpendicular	In-line	Housing mounting	Plate mounting	0.5 (Nil)	3 (L)	5 (Z)	None (N)									
Solid state auto switch	-	Grommet	Yes	3-wire (NPN)	5 V, 12 V	-	F7NV	F79	ø16	ø10	●	●	○	—	○	IC circuit							
				3-wire (PNP)							12 V	F7PV	F7P	●	●		○	—	○				
		2-wire		24 V	F7BV	J79	●	●			○	—	○	Relay, PLC									
	Diagnostic indication (2-color indicator)	Grommet	3-wire (NPN)	5 V, 12 V	-	F7NW	F79W	●			●	○	—		○								
			3-wire (PNP)					12 V			F7PW	—	○		—		○	○					
		2-wire	24 V	F7BW	J79W	●	●	○			—	○	—										
Water resistant (2-color indicator)	Grommet	Yes	4-wire (NPN)	5 V, 12 V	-	F7BAV**	F7BA***	●	●	○	—	○	○	—	IC circuit								
								2-wire	24 V	F79F	—	○	—	○		○							
Reed auto switch	-	Grommet	Yes	3-wire (NPN equivalent)	24 V	5 V, 12 V	200 V	A72	ø16	ø10	●	●	—	—	—	Relay, PLC							
											Connector	No	2-wire	12 V	100 V		A73	A73H	●	●	—	—	—
																			Grommet	Yes	3-wire (NPN equivalent)	5 V, 12 V	100 V or less
											Connector	No	2-wire	12 V	24 V or less		A73C	—					
																			Grommet	Yes	3-wire (NPN equivalent)	5 V, 12 V	100 V or less
											Connector	No	2-wire	12 V	24 V or less		A80C	—					
		Grommet	Yes	3-wire (NPN equivalent)	5 V, 12 V	100 V or less	E80A	—	●	●						—			—	—			

*** Water resistant type auto switches can be mounted on the above models, but in such case SMC cannot guarantee water resistance. Consult with SMC regarding water resistant types with the above model numbers.

* Lead wire length symbols: 0.5 m Nil (Example) F79W
 3 m L (Example) F79WL
 5 m Z (Example) F79WZ
 None N (Example) J79CN

* Solid state auto switches marked with "○" are produced upon receipt of order.
 ** It is impossible to mount solid state switches to the housing mounting ø10.

• Since there are other applicable auto switches than listed, refer to page 703 for details.
 • For details about auto switches with pre-wired connector, refer to pages 1192 and 1193.
 • Auto switches are shipped together (not assembled).

CX2
CXW
CXT
CXSJ
CXs

D-□
-X□

CXWM Series

Built-in shock absorber

This is a built-in shock absorber type in which the shock absorber is enclosed in the housing. Compared to the CX2 series with shock absorber, this type achieves space savings in the longitudinal direction (except 25 mm stroke).

Dramatically reduced installation labor

The machining precision required for positioning during the installation of the cylinder has been reduced through the adoption of a special pin hole machining process, thus decreasing the amount of labor involved in adjustment.

Provided with an end lock mechanism

An end lock is also available, which maintains the cylinder's original position even if the air supply is interrupted.

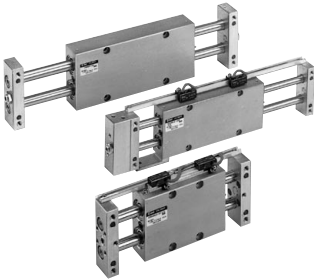

Made to Order: Individual Specifications
(For details, refer to pages 706 to 708.)

Symbol	Specifications
-X138	Adjustable stroke
-X146	Hollow piston rod
-X168	Helical insert thread
-X169	2 built-in magnets

Made to Order Specifications

[Click here for details](#)

Symbol	Specifications
-XB11	Long stroke type
-XB13	Low speed cylinder (5 to 50 mm/s)
-XC22	Fluororubber seal

Moisture Control Tube IDK Series



When operating an actuator with a small diameter and a short stroke at a high frequency, the dew condensation (water droplet) may occur inside the piping depending on the conditions.

Simply connecting the moisture control tube to the actuator will prevent dew condensation from occurring. For details, refer to [the IDK series in the Best Pneumatics No. 6](#).

Specifications

Type	Non-lube	
Fluid	Air	
Proof pressure	1.5 MPa	
Max. operating pressure	1.0 MPa	
Min. operating pressure	CXWM10/16	0.15 MPa
	CXWM20/25/32	0.1 MPa
Ambient & fluid temperature	-10 to 60°C (No freezing)	
Piston speed (Non-lube)	30 to 500 mm/s	
Cushion	Shock absorber	
Stroke adjustable range	Standard stroke: ±2 mm	
Accessory (Option)	Straight knock pin (2 pcs.), Adjusting bolt* (-X138)	

* -X138* has a stroke adjustable range of -12.5 mm on one side.

Maximum Load Weight/Non-rotating Accuracy/Maximum Holding Force

Model	CXWM10	CXWM16	CXWM20	CXWM25	CXWM32
Maximum load weight*	1 kg	4 kg	5 kg	6 kg	10 kg
Non-rotating accuracy (Deflection of a piston rod is not included.)	±0.09°	±0.03°	±0.03°	±0.02°	±0.01°
Maximum holding force (End lock model)	39.2 N	98.1 N	147.1 N	245.2 N	392.3 N

* Place the center of gravity of the load and center of the slide unit close during operation. If they are placed far apart from each other, please consult with SMC.

Shock Absorber Specifications

Shock absorber ⁽¹⁾	RB8005-X52	RB0805	RB1006-X52	RB1006	RB1411-X52	RB1411
Applicable slide unit	CXWM10/16-□□	CXWM20/25-□□	CXWM32-□□			
Maximum energy absorption (J)	0.98	3.92	14.7			
Stroke absorption (mm)	5	6	11			
Max. collision speed (m/sec)	0.05 to 5					
Max. operating frequency (cycle/min) ⁽²⁾	80	70	45			
Max. allowable thrust (N)	147	353	667			
Ambient temperature range (°C)	-10 to 80					
Spring force (N)	Extended	1.96	4.22	6.86		
	Retracted	3.83	6.18	15.30		
Weight (g)	15	25	65			

Note 1) "-X52" is an exclusive shock absorber installed in the housing, and is the screw not attached specification of the outer part of the outer tube. The shock absorber plate mounting type of 25 and 50 strokes have the screw attached specification.

Note 2) It denotes the values at the maximum energy absorption per one cycle. Therefore, the operating frequency can be increased according to the energy absorption.

* The shock absorber service life is different from that of the cylinder depending on the operating conditions. Refer to the RB series Specific Product Precautions for the replacement period.

Theoretical Output

Model	Rod size (mm)	Piston area (mm ²)	Operating pressure (MPa)								
			0.2	0.3	0.4	0.5	0.6	0.7	0.8	0.9	
CXWM10-□□	6	101	20	30	40	51	61	71	81	91	
CXWM16-□□	10	245	49	74	98	123	147	172	196	221	
CXWM20-□□	12	402	80	121	161	201	241	281	322	362	
CXWM25-□□	14	597	119	179	239	299	358	418	478	537	
CXWM32-□□	20	980	196	294	392	490	588	686	784	882	

(Note) Theoretical output (N) = Pressure (MPa) x Piston area (mm²)

Standard Stroke

Model	Standard stroke (mm)							
	25	50	75	100	125	150	175	200
CXWM10-□□	(*) ⁽¹⁾	●	●	●	—	—	—	—
CXWM16-□□	(*) ⁽¹⁾	●	●	●	●	●	●	●
CXWM20-□□	(*) ⁽²⁾	●	●	●	●	●	●	●
CXWM25-□□	(*) ⁽¹⁾	●	●	●	●	●	●	●
CXWM32-□□	(*) ⁽²⁾	(*) ⁽²⁾	●	●	●	●	●	●

Note 1) The strokes marked with "(*)" has an absorber of double side plate mounting type.

Note 2) The strokes marked with "(*)" has an absorber of single side plate mounting type.

Weight

(kg)

Model	Stroke (mm)							
	25	50	75	100	125	150	175	200
CXWM10	0.28	0.35	0.42	0.49	—	—	—	—
CXWM16	0.46	0.59	0.72	0.85	0.98	1.11	1.24	1.37
CXWM20	0.69	0.87	1.03	1.22	1.40	1.58	1.75	1.93
CXWM25	0.95	1.17	1.38	1.60	1.82	2.03	2.31	2.47
CXWM32	2.01	2.38	2.77	3.16	3.56	3.94	4.34	4.72

Additional Weight with End Lock (CXWM□-□R)

(kg)

Applicable model	Additional weight
CXWM10	0.08
CXWM16	0.14
CXWM20	0.15
CXWM25	0.20
CXWM32	0.43

Operating Direction with Different Pressure Ports

Operating direction of housing when the plate is fixed

With end lock (CXWM□R)
Operating direction of housing when the plate is fixed

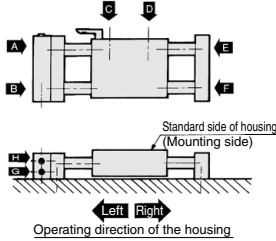
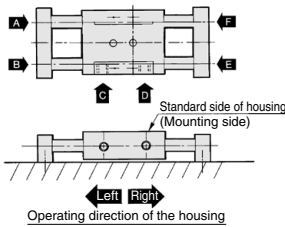

Pressure port	A	B	C	D	E	F
Operating direction	Right	Left	Left	Right	Left	Right

* There are 9 possible reciprocating piping methods.

Pressure port	A	B	C	D	E	F	G	H
Operating direction	Right	Left	Left	Right	Left	Left	Right	Right

* There are 16 possible reciprocating piping methods.

**Accessory
Straight Knock Pin (Option)**

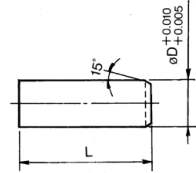

Model	L	øD	Model*
CXWM10	10	4	MS4-10
CXWM16	10	5	MS5-10
CXWM20	15	6	MS6-15
CXWM25	15	6	MS6-15
CXWM32	20	8	MS8-20

* Manufactured by Misumi Trading Ltd.

Deflection of Piston Rod by Center Loading (Reference)

When center loading is added to the center of the housing

When center loading is added to the center of the plate

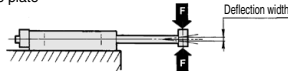
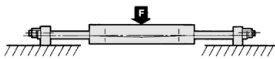

Model	Stroke		
	Load (N)	100	200
CXWM10	9.81	0.07	—
CXWM16	39.2	0.05	0.20
CXWM20	49	0.04	0.15
CXWM25	58.8	0.02	0.08
CXWM32	98.1	0.02	0.07

Model	Stroke				
	Load (N)	50	100	150	200
CXWM10	2.94	0.06	0.30	—	—
CXWM16	4.90	0.03	0.10	0.25	0.45
CXWM20	7.84	0.03	0.09	0.18	0.35
CXWM25	9.81	0.03	0.09	0.16	0.25
CXWM32	29.42	0.02	0.05	0.10	0.15

Note) The values denote the total width of the deflections in the upward/downward direction.

CX2

CXW

CXT

CXSJ

CXS

D-□

-X□

CXWM Series

Construction: $\varnothing 10$, $\varnothing 16$, $\varnothing 25$

CXWM10

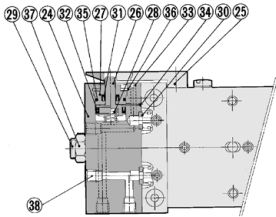

With end lock

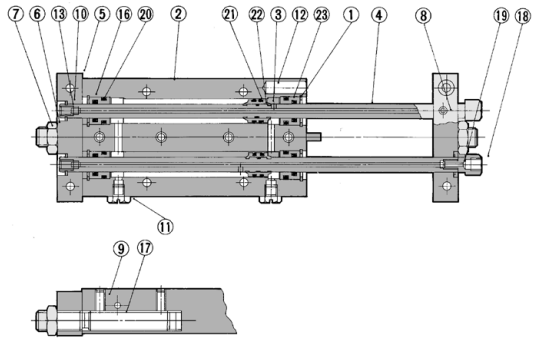

CXWM16, 25

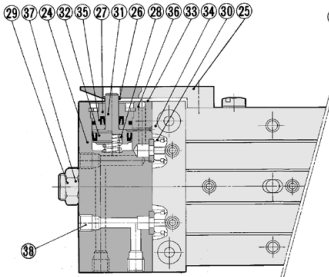

$\varnothing 16$ /With end lock

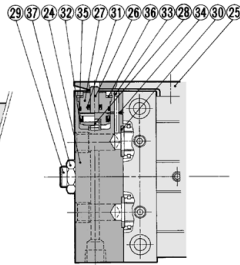

$\varnothing 25$ /With end lock

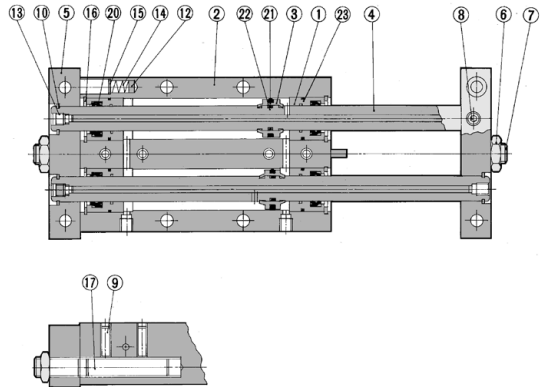

Construction: $\varnothing 10, \varnothing 16, \varnothing 25$

Component Parts

No.	Description	Material	Note
1	Rod cover	Aluminum bearing alloy	
2	Housing	Aluminum alloy	Hard anodized
3	Piston	Aluminum alloy	Chromated
4	Piston rod	Carbon steel piping for machine constructions	Hard chrome plated
5	Plate	Aluminum alloy	Hard anodized
6	Lock nut	Carbon steel	Nickel plated
7	Adjustment bolt	Chromium steel	Nickel plated
8	Set screw (For fixing rods)	Chromium steel	Nickel plated
9	Set screw (For fixing shock absorbers)	Stainless steel	
10	Retaining ring	Carbon tool steel	Phosphate coated
11	Plug	Brass	Nickel plated
12	Magnet	—	$\varnothing 5$
13	Set screw for seal	Chromium steel	Nickel plated
14	Spring	Stainless steel	
15	Type CR retaining ring	Carbon tool steel	
16	Round type R retaining ring	Carbon tool steel	Phosphate coated
17	Shock absorber	—	(RB0805-X552 or RB1006-X552)
18	Socket	Brass	Electroless nickel plated
19	Gasket	NBR	
20	Rod seal	NBR	
21	Piston seal	NBR	
22	Piston gasket	NBR	
23	Cylinder tube gasket	NBR	

**Replacement Parts: Seal Kit
Cylinder Body**

Model	Kit no.	Contents
CXWM10	CXWM10-PS	Set of nos. above 20, 21, 23
CXWM16	CXWM16-PS	
CXWM25	CXWM25-PS	

* Seal kit includes 20, 21, 23. Order the seal kit, based on each bore size. (The piston gasket 22 is not replaceable.)

* Since the seal kit does not include a grease pack, order it separately.
Grease pack part no.: GR-S-010 (10 g)

Component Parts: With End Lock

No.	Description	Material	Note
24	Locking body	Aluminum alloy	Hard anodized
25	Lock finger	Alloy tool steel	Nickel plated after quenched
26	Lock piston	Carbon tool steel	Electroless nickel plated after quenched
27	Rod cover	Aluminum alloy	
28	Return spring	Spring steel	Zinc chromated
29	Adjustment bolt	Chromium steel	Nickel plated
30	Body gasket	NBR	
31	Rod seal	NBR	
32	Piston seal	NBR	
33	Steel ball	High carbon chrome bearing steel	
34	Steel ball	High carbon chrome bearing steel	
35	O-ring	NBR	
36	Round type R retaining ring	Carbon tool steel	Phosphate coated
37	Lock nut	Carbon steel	Nickel plated
38	Plug	Chromium steel	Nickel plated

**Replacement Parts: Seal Kit
End Lock**

Model	Kit no.	Contents
CXWM10	CXWM10R-PS	Set of nos. above 30, 31, 32, 35
CXWM16	CXWM16R-PS	
CXWM25	CXWM25R-PS	

* Seal kit includes 30, 31, 32, 35. Order the seal kit, based on each bore Ssize.

* Since the seal kit does not include a grease pack, order it separately.
Grease pack part no.: GR-S-010 (10 g)

CX2

CXW

CXT

CXSJ

CXS

D-□

-X□

CXWM Series

Construction: $\varnothing 20$, $\varnothing 32$

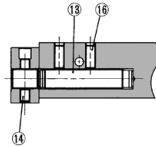
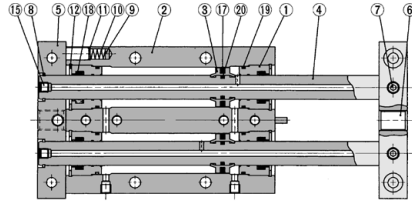

With end lock

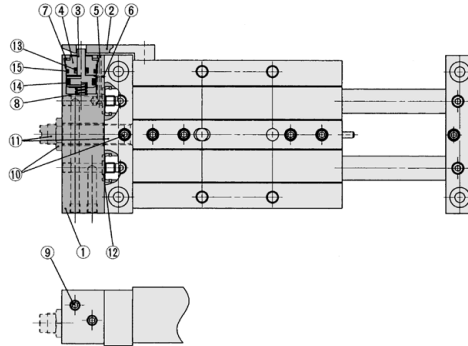

Component Parts

No.	Description	Material	Note
1	Rod cover	Aluminum bearing alloy	
2	Housing	Aluminum alloy	Hard anodized
3	Piston	Aluminum alloy	Chromated
4	Piston rod	Carbon steel for machines	Hard chrome plated
5	Plate	Aluminum alloy	Hard anodized
6	Adjustment bolt	Chromium steel	Nickel plated
7	Hexagon socket head set screw	Chromium steel	Nickel plated
8	Retaining ring	Tool steel	Phosphate coated
9	Magnet	—	
10	Spring	Stainless steel	
11	Type CR retaining ring	Carbon tool steel	
12	Round type R retaining ring	Carbon tool steel	Phosphate coated
13	Shock absorber	—	RB1006-X552, RB1411-X552
14	Hexagon socket head set screw	Chromium steel	Nickel plated
15	Hexagon socket head plug	Chromium steel	Nickel plated
16	Hexagon socket head set screw	Chromium steel	Nickel plated
17	Piston seal	NBR	
18	Rod seal	NBR	
19	Cylinder tube gasket	NBR	
20	Piston gasket	NBR	

Replacement Parts: Seal Kit Cylinder Body

Model	Kit no.	Contents
CXWM20	CXWM20-PS	Set of nos. above 17, 18, 19
CXWM32	CXWM32-PS	

* Seal kit includes 17, 18, 19. Order the seal kit, based on each bore size. (The piston gasket 20 is not replaceable.)

* Since the seal kit does not include a grease pack, order it separately.
Grease pack part no.: GR-S-010 (10 g)

Component Parts: With End Lock

No.	Description	Material	Note
1	Locking body	Aluminum alloy	Hard anodized
2	Lock finger	Alloy tool steel	Nickel plated after quenched
3	Lock piston	Tool steel	Electroless nickel plated after quenched
4	Rod cover	Aluminum bearing alloy	
5	Steel ball	High carbon chrome bearing steel	
6	Steel ball	High carbon chrome bearing steel	
7	Round type R retaining ring	Carbon tool steel	Phosphate coated
8	Plug	Spring steel	Zinc chromated
9	Plug	Chromium steel	Nickel plated
10	Hexagon nut	Chromium steel	Nickel plated
11	Adjustment bolt	Chromium steel	Nickel plated
12	Body gasket	NBR	
13	Rod seal	NBR	
14	Piston seal	NBR	
15	O-ring	NBR	

Note) The strokes indicated in the parentheses are of CXWM20, and CXWM32 includes the strokes indicated in the parentheses.

Replacement Parts: Seal Kit End Lock

Model	Kit no.	Contents
CXWM20	CXWM20R-PS	Set of nos. above 12, 13, 14, 15
CXWM32	CXWM32R-PS	

* Seal kit includes 12, 13, 14, 15. Order the seal kit, based on each bore size.

* Since the seal kit does not include a grease pack, order it separately.
Grease pack part no.: GR-S-010 (10 g)

Slide Unit: Built-in Shock Absorber
Slide Bearing Type **CXWM Series**

ø10 Basic Type: CXWM10-Stroke/50 to 100

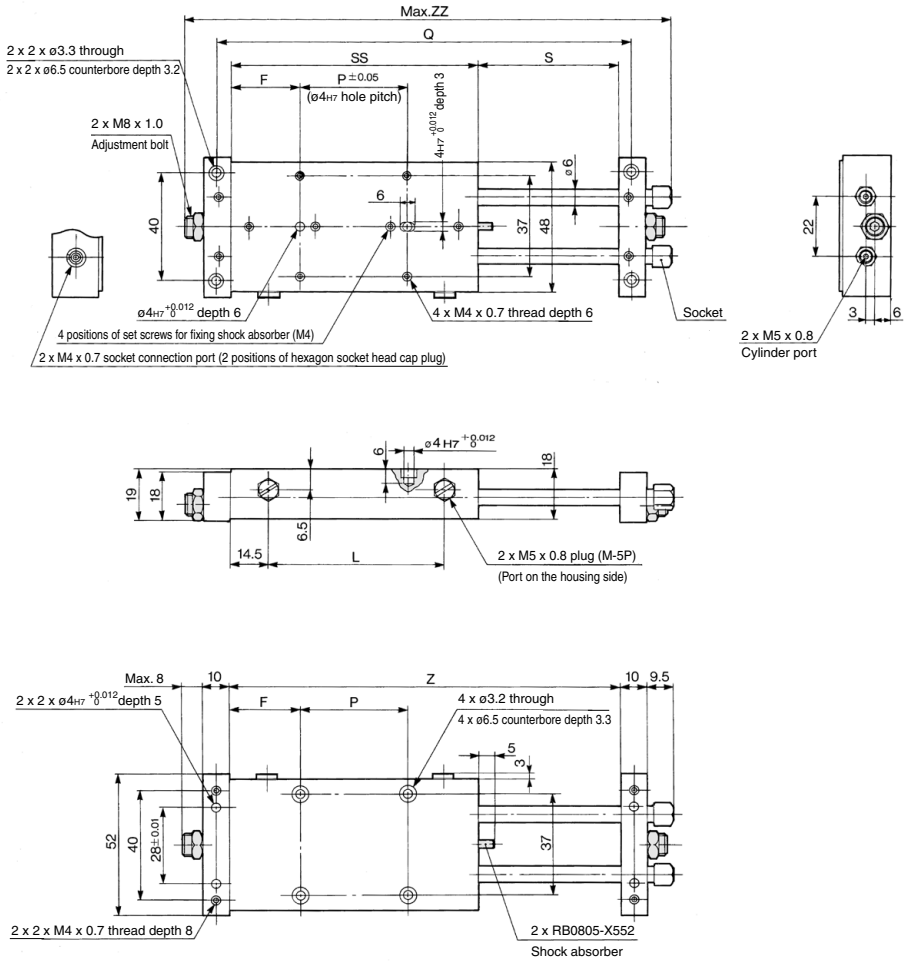

Note) For 25 stroke, the shock absorber is mounted on a plate. For dimensions of the 25 stroke, refer to page 666.

Model	F	L	P	Q	S	SS	Z	ZZ
CXWM10-50	26	63	40	154	52	92	144	181.5
CXWM10-75	26	88	65	204	77	117	194	231.5
CXWM10-100	26	113	90	254	102	142	244	281.5

(mm)

CX2

CXW

CXT

CXSJ

CXS

D-□

-X□

CXWM Series

ø10 Basic Type: CXWM10-25 stroke

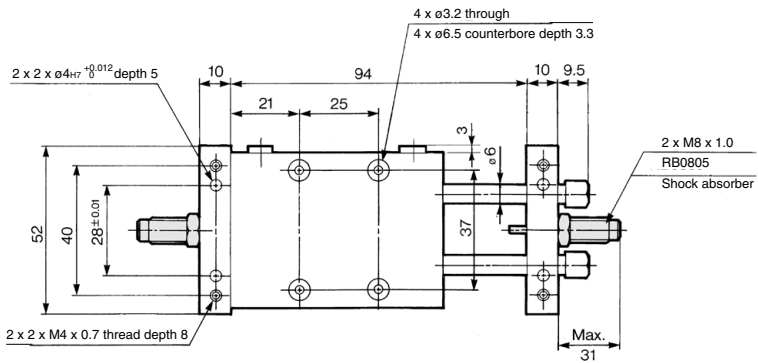
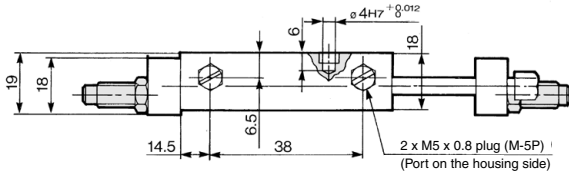
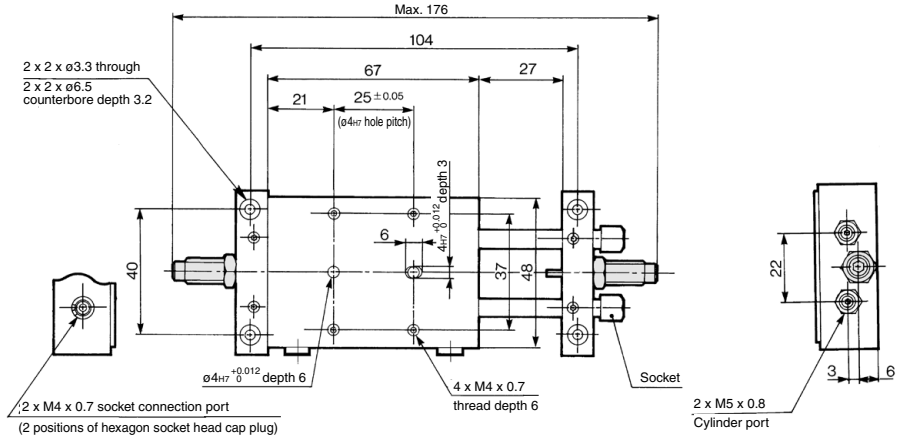

CXWM Series

ø10 With End Lock: CXWM10-25 Stroke R

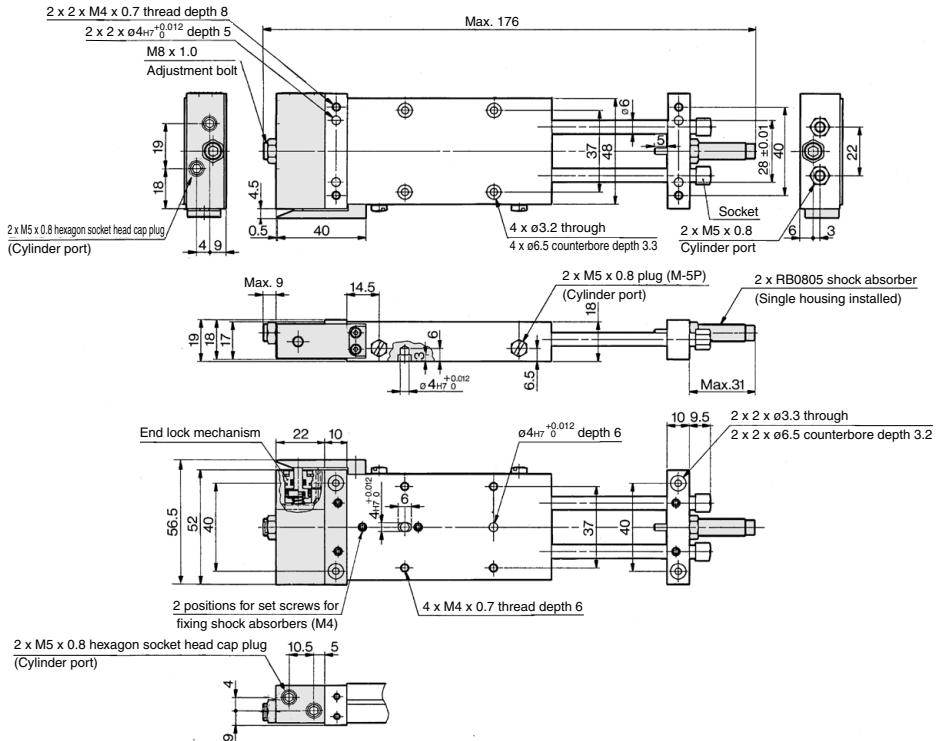

Housing mounting type with auto switch CDBXWM10-25, CDBXWM10-25R

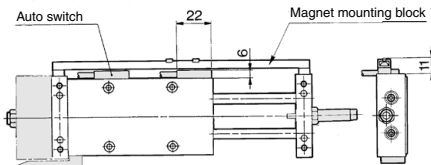
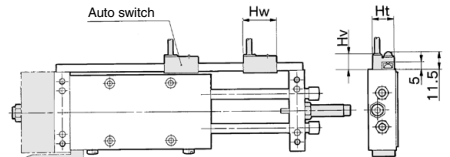

Plate mounting type with auto switch CDPXWM10-25, CDPXWM10-25R



Note 1) The dimensions show D-E7□A and D-E80A.
 Note 2) 2 magnets for auto switches are equipped to the magnet mounting block.

Note 1) The dimensions show D-A7 and D-A8. (mm)

Auto switch model	Hw	Ht	Hv
D-A7□, D-A80	23	15	10.5
D-F7□, D-J79, D-J79W, D-F7□W, D-F79F, D-F7BA, D-F7NT	23	15	10
D-A7□H, D-A80H	22	15	9
D-A73C, D-A80C	23	17.5	17.5
D-F7□V, D-F7□WV, D-F7BAV	23	15	14
D-J79C	24	17.5	16

Note 2) 2 magnets for auto switches are installed in the housing.

Slide Unit: Built-in Shock Absorber
Slide Bearing Type **CXWM Series**

ø16 Basic Type: CXWM16-Stroke/50 to 200

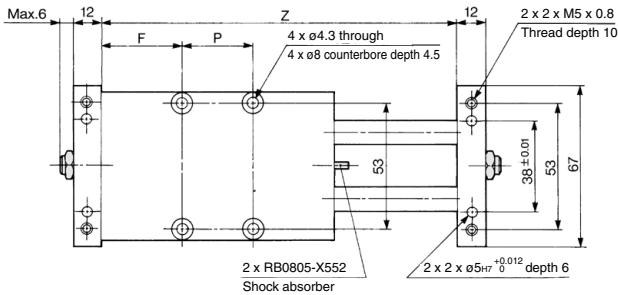
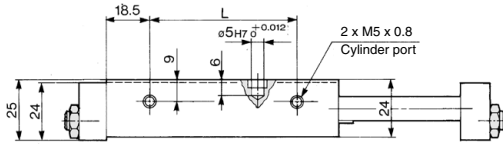
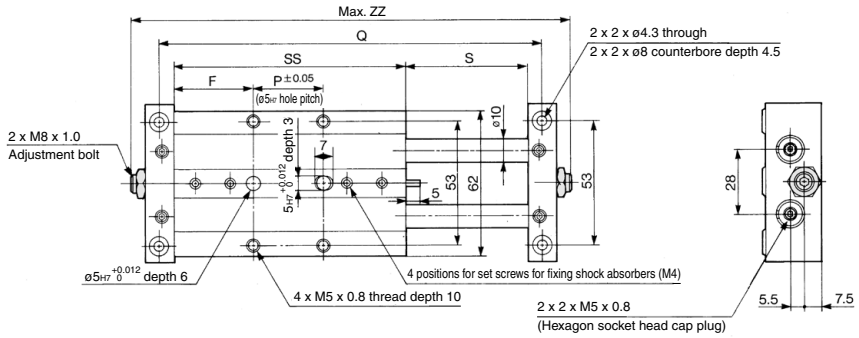

Note) For 25 stroke, the shock absorber is mounted on a plate.
Refer to page 670 for the dimensions of the 25 stroke.

Model	F	L	P	Q	S	SS	Z	ZZ
CXWM16-50	35	63	30	164	52	100	152	188
CXWM16-75	32.5	88	60	214	77	125	202	238
CXWM16-100	37.5	113	75	264	102	150	252	288
CXWM16-125	42.5	138	90	314	127	175	302	338
CXWM16-150	55	163	90	364	152	200	352	388
CXWM16-175	67.5	188	90	414	177	225	402	438
CXWM16-200	80	213	90	464	202	250	452	488

CX2

CXW

CXT

CXSJ

CXS

D-□

-X□

CXWM Series

ø16 Basic Type: CXWM16-25 stroke

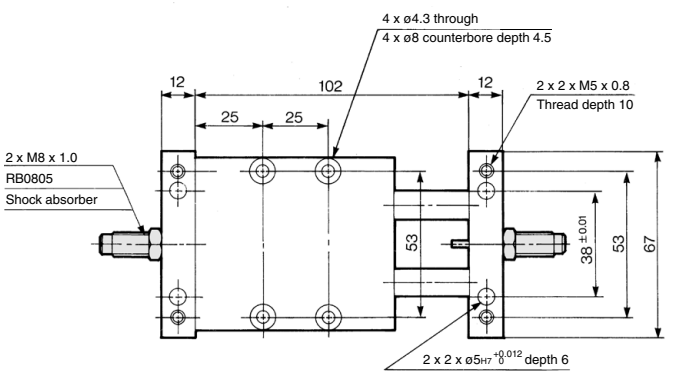
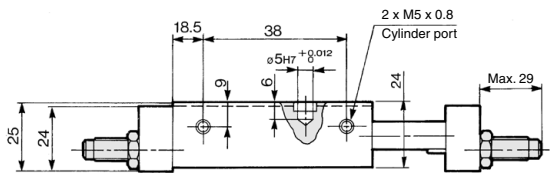
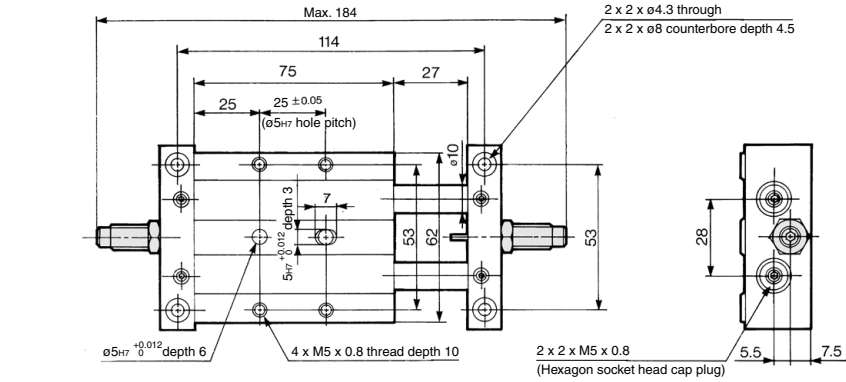

CXWM Series

ø16 With End Lock: CXWM16-25 stroke R

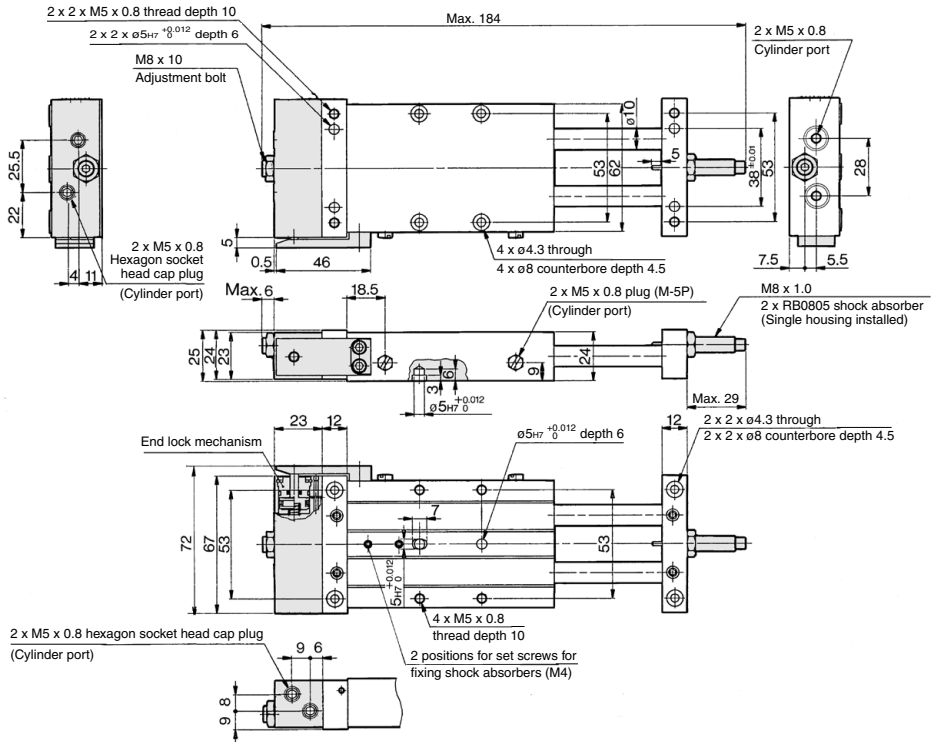

Housing mounting type with auto switch CDBXWM16-25, CDBXWM16-25R

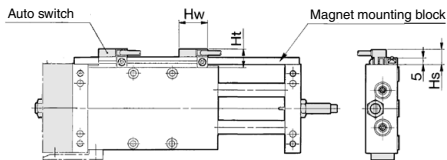

Note 1) The dimensions show D-A7 and D-A8. (mm)

Auto switch model	Hw	Hs	Ht
D-A7□, D-A80	23	12.5	15
D-F7□, D-J79, D-J79W, D-F7□W, D-F79F, D-F7BA, D-F7NT	23	12.5	15
D-A7□H, D-A80H	22	12.5	15
D-A73C, D-A80C	23	15	17.5
D-F7□V, D-F7□WV, D-F7BAV	23	12.5	15
D-J79C	24	15	17.5
D-F7LF	30	12.5	15

Note 2) 2 magnets for auto switches are equipped to the magnet mounting block.

Plate mounting type with auto switch CDPXWM16-25, CDPXWM16-25R

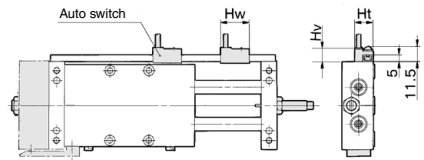

Note 1) The dimensions show D-A7 and D-A8. (mm)

Auto switch model	Hw	Ht	Hv
D-A7□, D-A80	23	15	10.5
D-F7□, D-J79, D-J79W, D-F7□W, D-F79F, D-F7BA, D-F7NT	23	15	10
D-A7□H, D-A80H	22	15	9
D-A73C, D-A80C	23	17.5	17.5
D-F7□V, D-F7□WV, D-F7BAV	23	15	14
D-J79C	24	17.5	16

Note 2) 2 magnets for auto switches are installed in the housing.

Slide Unit: Built-in Shock Absorber **CXWM Series**

ø20 Basic Type: CXWM20-Stroke/50 to 200

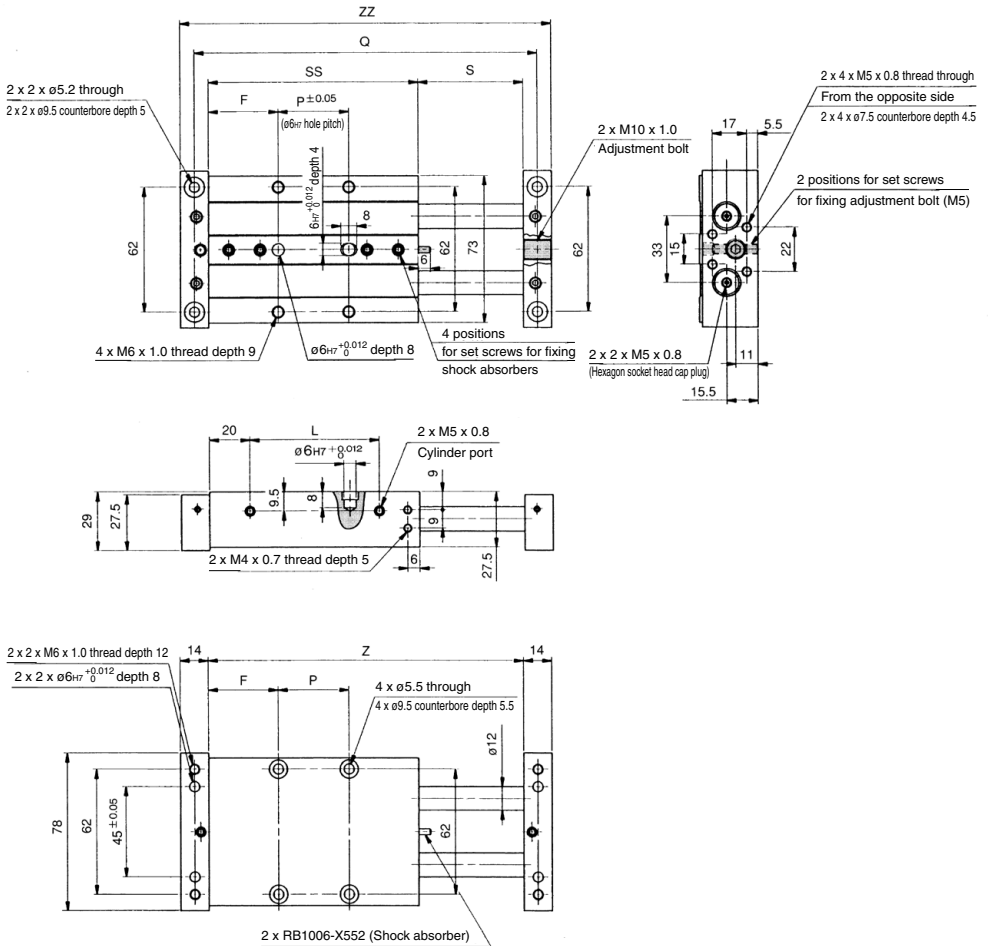

Model	F	L	P	Q	S	SS	Z	ZZ
CXWM20-50	34.5	64	35	170	52	104	156	184
CXWM20-75	34.5	89	60	220	77	129	206	234
CXWM20-100	39.5	114	75	270	102	154	256	284
CXWM20-125	44.5	139	90	320	127	179	306	334
CXWM20-150	57	164	90	370	152	204	356	384
CXWM20-175	69.5	189	90	420	177	229	406	434
CXWM20-200	82	214	90	470	202	254	456	484

(mm)
Note) For 25 stroke, the shock absorber is mounted on a single side of the plate. For dimensions of 25 stroke, refer to page 674.

CX2

CXW

CXT

CXSJ

CXS

D-□

-X□

CXWM Series

ø20 Basic Type: CXWM20-25 stroke

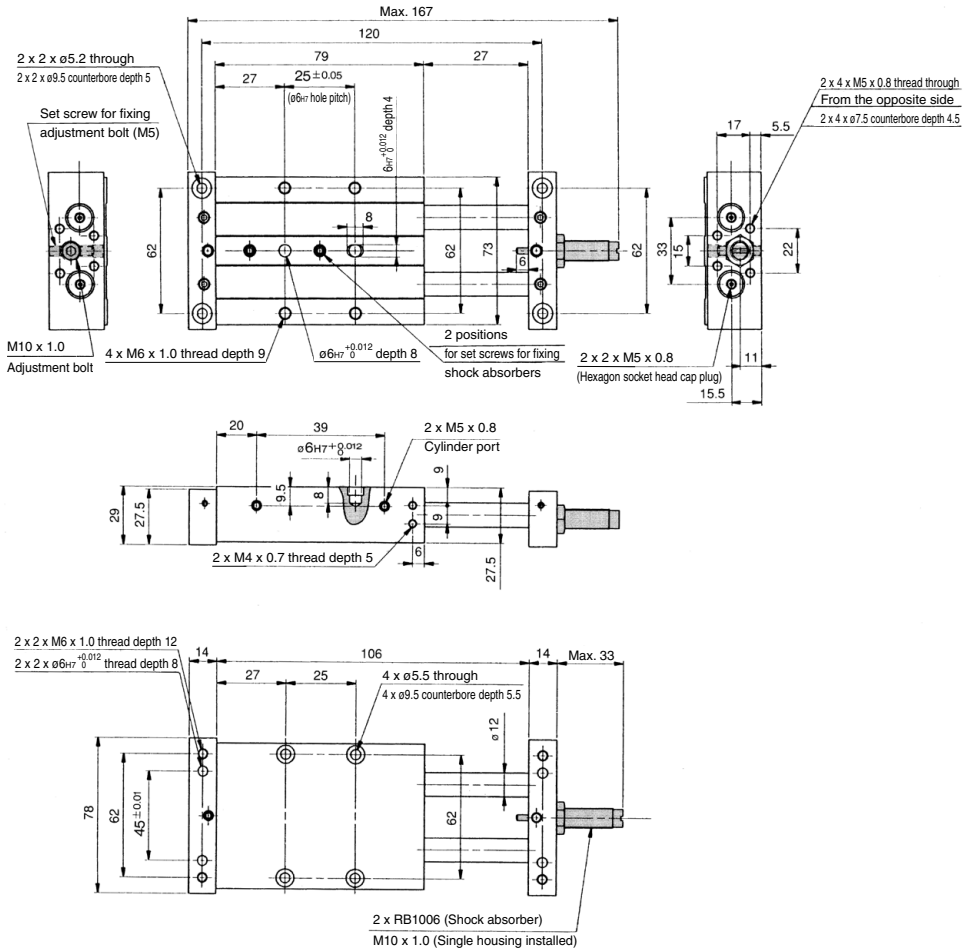

CXWM Series

ø20 With End Lock: CXWM20-25 stroke R

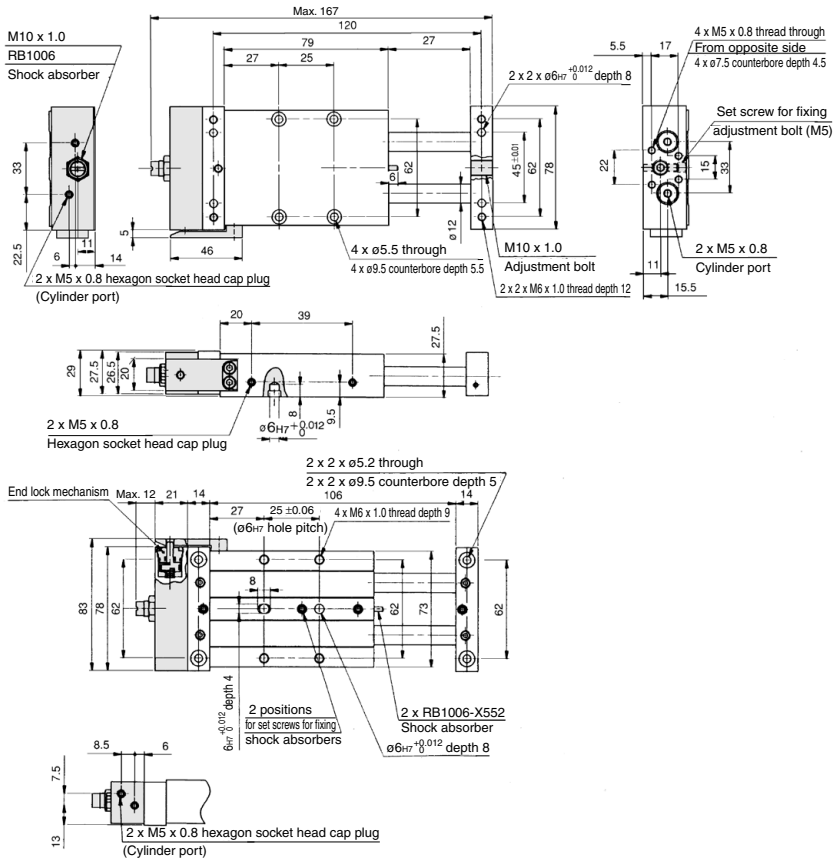

Housing mounting type with auto switch CDBXWM20-25, CDBXWM20-25R

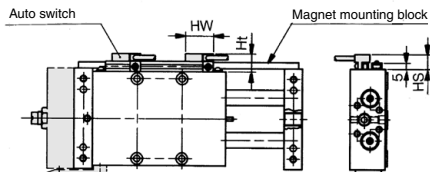

Note 1) The dimensions show D-A7 and D-A8. (mm)

Auto switch model	Hw	Hs	Ht
D-A7□, D-A80	23	12.5	15
D-F7□, D-J79, D-J79W, D-F7□W, D-F79F, D-F7BA, D-F7NT	23	12.5	15
D-A7□H, D-A80H	22	12.5	15
D-A73C, D-A80C	23	15	17.5
D-F7□V, D-F7□WV, D-F7BAV	23	12.5	15
D-J79C	24	15	17.5
D-F7LF	30	12.5	15

Note 2) 2 magnets for auto switches are equipped to the magnet mounting block.

Plate mounting type with auto switch CDPXWM20-25, CDPXWM20-25R

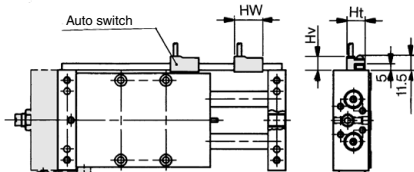

Note 1) The dimensions show D-A7 and D-A8. (mm)

Auto switch model	Hw	Ht	Hv
D-A7□, D-A80	23	15	10.5
D-F7□, D-J79, D-J79W, D-F7□W, D-F79F, D-F7BA, D-F7NT	23	15	10
D-A7□H, D-A80H	22	15	9
D-A73C, D-A80C	23	17.5	17.5
D-F7□V, D-F7□WV, D-F7BAV	23	15	14
D-J79C	24	17.5	16

Note 2) 2 magnets for auto switches are installed in the housing.

Slide Unit: Built-in Shock Absorber
Slide Bearing Type **CXWM Series**

ø25 Basic Type: CXWM25-Stroke/50 to 200

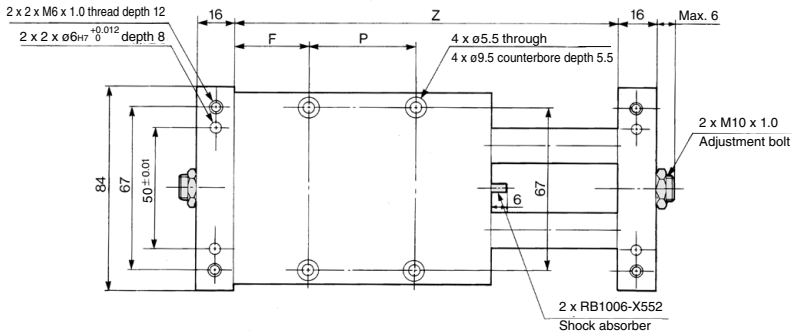
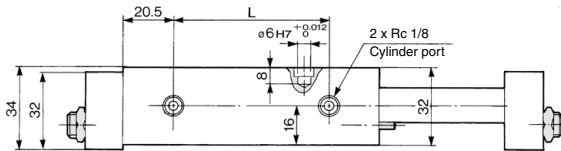
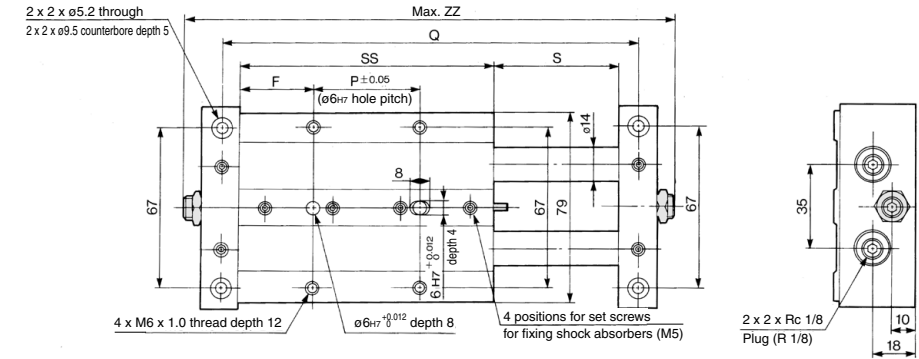

Note) For 25 stroke, the shock absorber is mounted on a plate.
For dimensions of 25 stroke, refer to page 678.

Model	F	L	P	Q	S	SS	Z	ZZ
CXWM25-50	31	66	45	175	52	107	159	203
CXWM25-75	33.5	91	65	225	77	132	209	253
CXWM25-100	33.5	116	90	275	102	157	259	303
CXWM25-125	46	141	90	325	127	182	309	353
CXWM25-150	58.5	166	90	375	152	207	359	403
CXWM25-175	71	191	90	425	177	232	409	453
CXWM25-200	83.5	216	90	475	202	257	459	503

CX2

CXW

CXT

CXSJ

CXS

D-□

-X□

CXWM Series

ø25 Basic Type: CXWM25-25 stroke

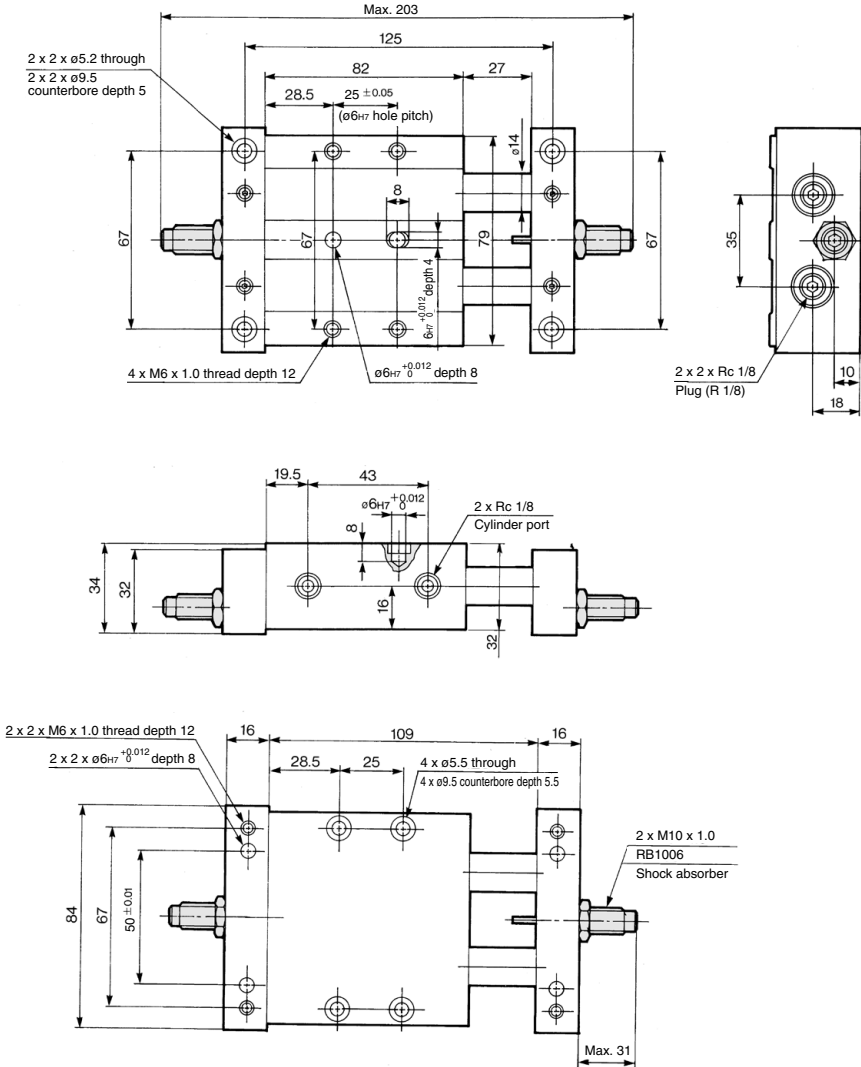

CXWM Series

ø25 With End Lock: CXWM25-25 stroke R

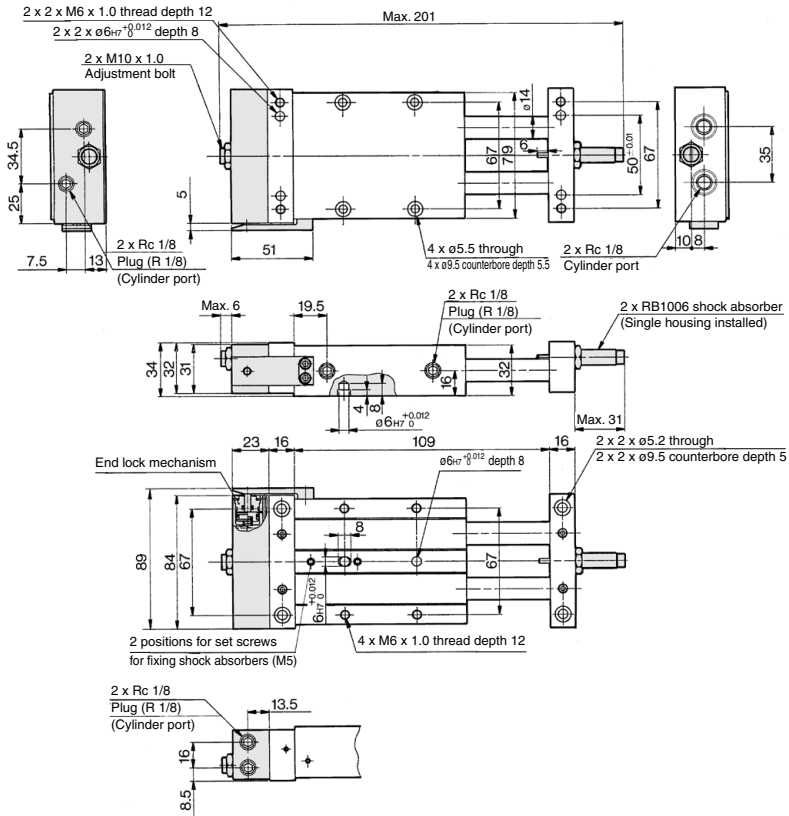

Housing mounting type with auto switch CDBXWM25-25, CDBXWM25-25R

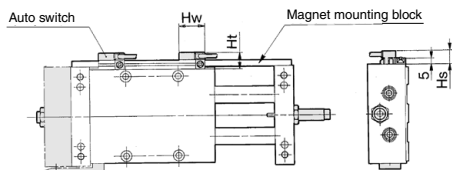

Note 1) The dimensions show D-A7 and D-A8. (mm)

Auto switch model	Hw	Hs	Ht
D-A7□, D-A80	23	12.5	15
D-F7□, D-J79, D-J79W, D-F7□W, D-F79F, D-F7BA, D-F7NT	23	12.5	15
D-A7□H, D-A80H	22	12.5	15
D-A73C, D-A80C	23	15	17.5
D-F7□V, D-F7□WV, D-F7BAV	23	12.5	15
D-J79C	24	15	17.5
D-F7LF	30	12.5	15

Note 2) 2 magnets for auto switches are equipped to the magnet mounting block.

Plate mounting type with auto switch CDPXWM25-25, CDPXWM25-25R

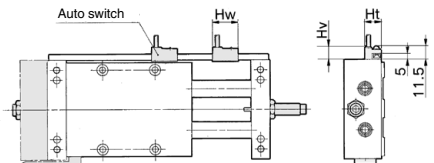

Note 1) The dimensions show D-A7 and D-A8. (mm)

Auto switch model	Hw	Ht	Hv
D-A7□, D-A80	23	15	10.5
D-F7□, D-J79, D-J79W, D-F7□W, D-F79F, D-F7BA, D-F7NT	23	15	10
D-A7□H, D-A80H	22	15	9
D-A73C, D-A80C	23	17.5	17.5
D-F7□V, D-F7□WV, D-F7BAV	23	15	14
D-J79C	24	17.5	16

Note 2) 2 magnets for auto switches are installed in the housing.

ø32 Basic Type: CXWM32-Stroke/75 to 200

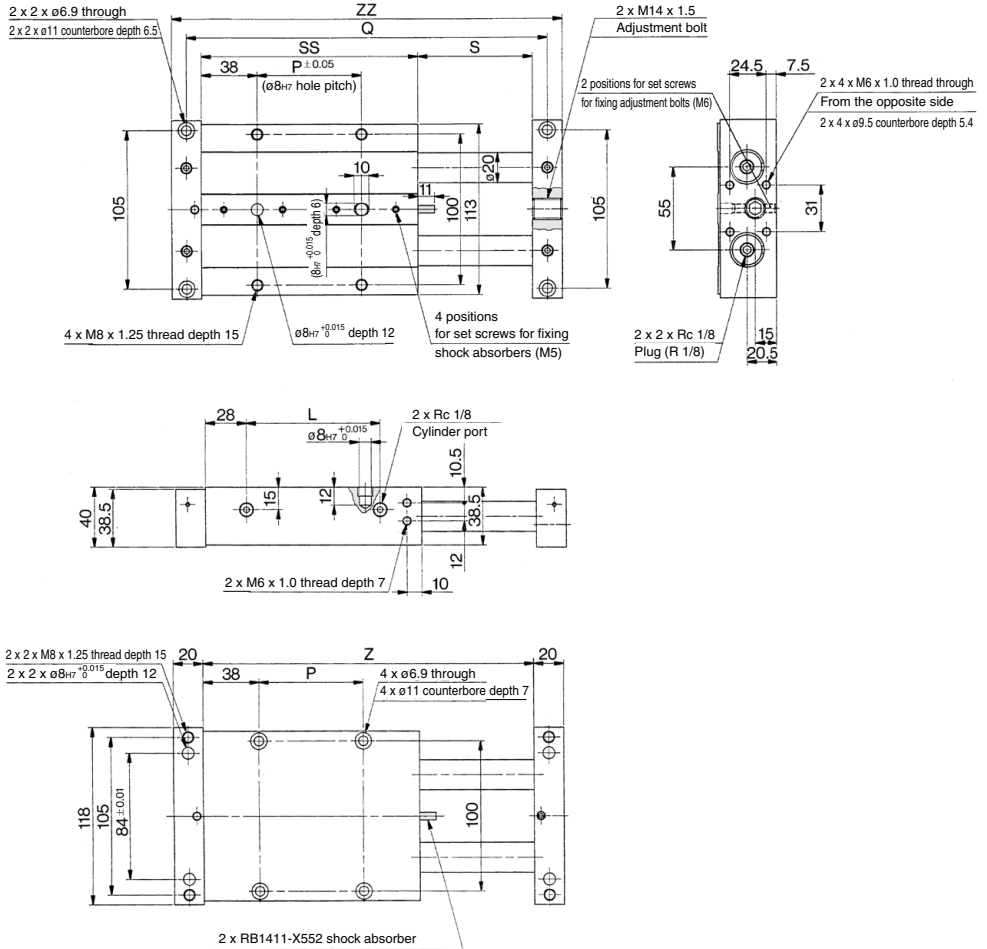

Model	L	P	Q	S	SS	Z	ZZ
CXWM32-75	90	70	243	77	146	223	263
CXWM32-100	115	95	293	102	171	273	313
CXWM32-125	140	120	343	127	196	323	363
CXWM32-150	165	145	393	152	221	373	413
CXWM32-175	190	170	443	177	246	423	463
CXWM32-200	215	195	493	202	271	473	513

Note) For 25 and 50 strokes, the shock absorber is mounted on a single side of the plate. For dimensions of 25 and 50 strokes, refer to page 682.

CX2

CXW

CXT

CXSJ

CXS

D-□

-X□

CXWM Series

ø32 Basic Type: CXWM32-Stroke/25, 50

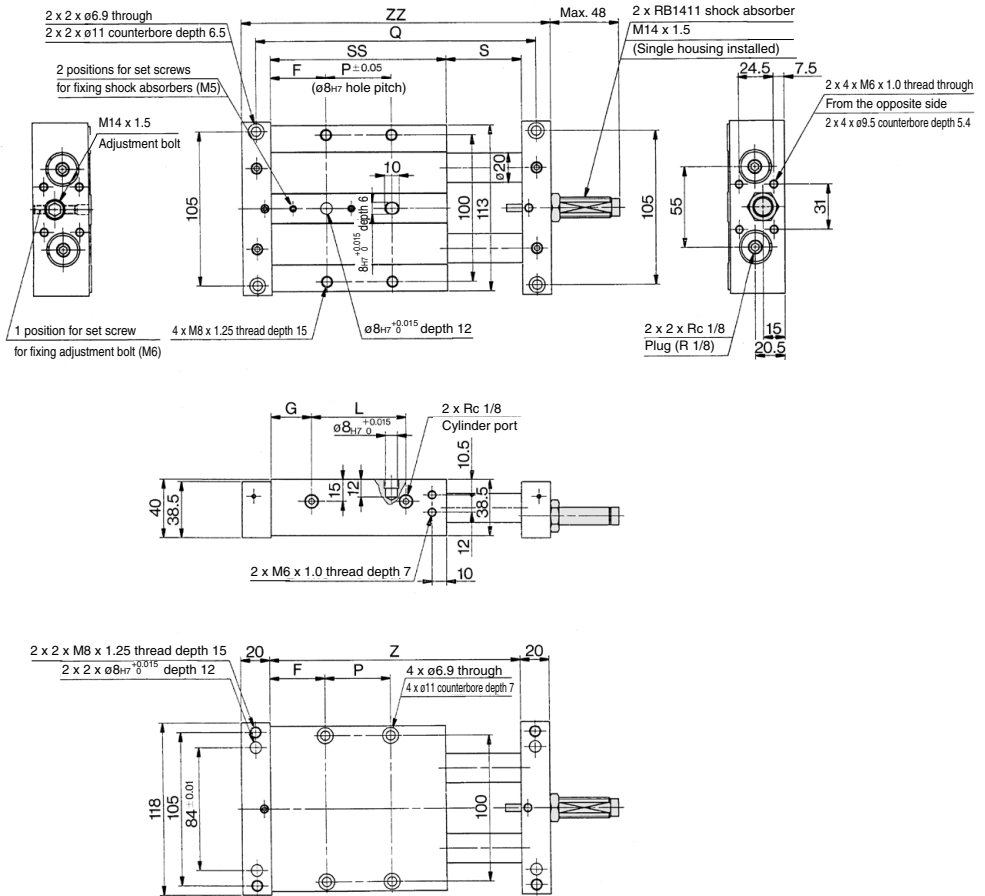

(mm)

Model	F	L	P	Q	S	SS	G	Z	ZZ
CXWM32-25	37	41	22	143	27	96	27.5	123	163
CXWM32-50	38	65	45	193	52	121	28	173	213

ø32 With End Lock: CXWM32-Stroke/75 to 200 R

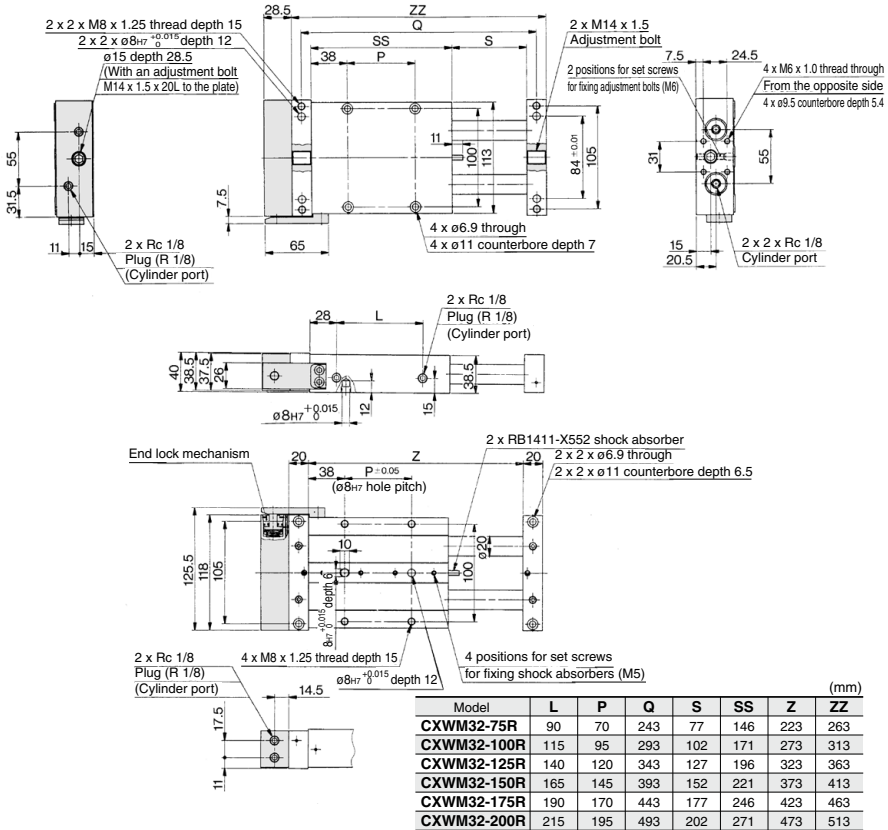

Housing mounting type with auto switch
CDBXWM32-Stroke, CDBXWM32-Stroke R

Plate mounting type with auto switch
CDPXWM32-Stroke, CDPXWM32-Stroke R

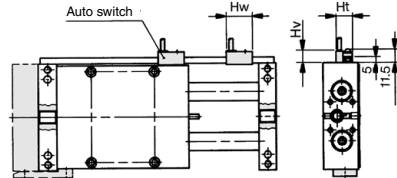
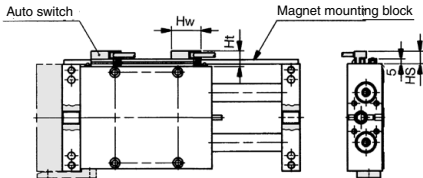

Note 1) The dimensions show D-A7 and D-A8. (mm)

Auto switch model	Hw	Hs	Ht
D-A7□, D-A80	23	12.5	15
D-F7□, D-J79, D-J79W, D-F7□W, D-F79F, D-F7BA, D-F7NT	23	12.5	15
D-A7□H, D-A80H	22	12.5	15
D-A73C, D-A80C	23	15	17.5
D-F7□V, D-F7□WV, D-F7BAV	23	12.5	15
D-J79C	24	15	17.5
D-F7LF	30	12.5	15

Note 2) For 25 and 50 stroke, the shock absorber is mounted on a single side of the plate. For dimensions of 25 and 50 strokes, refer to page 684.

Note 1) The dimensions show D-A7 and D-A8. (mm)

Auto switch model	Hw	Ht	Hv
D-A7□, D-A80	23	15	10.5
D-F7□, D-J79, D-J79W, D-F7□W, D-F79F, D-F7BA, D-F7NT	23	15	10
D-A7□H, D-A80H	22	15	9
D-A73C, D-A80C	23	17.5	17.5
D-F7□V, D-F7□WV, D-F7BAV	23	15	14
D-J79C	24	17.5	16

Note 2) For 25 and 50 stroke, the shock absorber is mounted on a single side of the plate. For dimensions of 25 and 50 strokes, refer to page 684.

CX2

CXW

CXT

CXSJ

CXS

D-□

-X□

Slide Unit: Built-in Shock Absorber Ball Bushing Bearing Type CXWL Series

ø10, ø16, ø20, ø25, ø32

How to Order

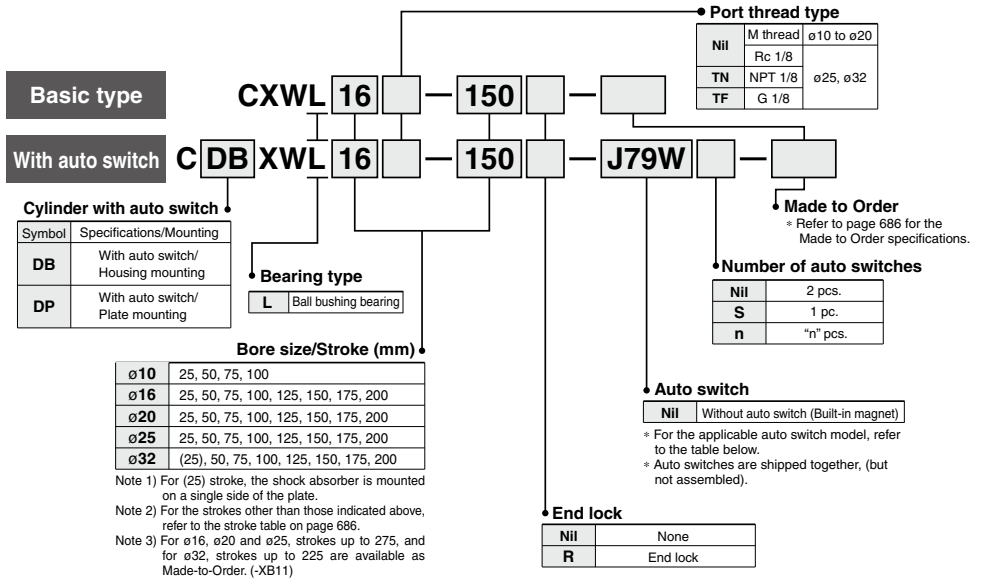

Applicable Auto Switches

Refer to pages 1119 to 1245 for further information on auto switches.

Type	Special function	Electrical entry	Indicator light	Wiring (Output)	Load voltage		Rail mounting		Applicable cylinder size		Lead wire length (m) [*]				Pre-wired connector	Applicable load				
					DC	AC	Perpendicular	In-line	Housing mounting	Plate mounting	0.5 (Nil)	3 (L)	5 (Z)	None (N)						
Solid state auto switch	—	Grommet	—	3-wire (NPN)	5 V, 12 V	—	F7NV	F79	ø16	ø10	●	●	○	—	○	IC circuit				
				3-wire (PNP)			F7PV	F7P			●	●	○	—	○					
				2-wire			F7BV	J79			●	●	○	—	○					
	Diagnostic indication (2-color indicator)	Grommet	Yes	3-wire (NPN)	24 V	5 V, 12 V	J79C	—			●	●	○	—	○		—	○	IC circuit	
				3-wire (PNP)			F7NW	F79W			●	●	○	—	○					
				2-wire			—	F7PW			●	●	○	—	○					
Water resistant (2-color indicator)	Grommet	—	2-wire	12 V	—	F7BWV	J79W	●	●	○	—	○	—	○	—					
						With diagnostic output (2-color indicator)	Yes	4-wire (NPN)	5 V, 12 V	—	F7BAV***	F7BA***	●	●		○	—	○	IC circuit	
											—	F79F	●	●		○	—	○		
Reed auto switch	—	Grommet	Yes	3-wire (NPN equivalent)	—	5 V	—	A76H	ø16	ø10	●	●	○	—	○	IC circuit				
							2-wire	24 V			—	200 V	A72	A72H	●		●	○	—	○
													12 V	100 V	A73		A73H	●	●	○
		Connector	No/Yes	2-wire	24 V	—	5 V, 12 V	100 V or less			A80	A80H	●	●	○		—	○	IC circuit	
								12 V			—	A73C	—	●	●		○	—		○
								5 V, 12 V			24 V or less	A80C	—	●	●		○	—		○
Grommet	No	3-wire (NPN equivalent)	24 V	—	5 V	12 V	100 V	E76A	ø10	—	●	●	○	—	○	—				
							—	E73A			●	●	○	—	○					
							5 V, 12 V	100 V or less			E80A	●	●	○	—		○			

*** Water resistant type auto switches can be mounted on the above models, but in such case SMC cannot guarantee water resistance. Consult with SMC regarding water resistant types with the above model numbers.

* Lead wire length symbols: 0.5 m Nil (Example) F79W
3 m L (Example) F79WL
5 m Z (Example) F79WZ
None N (Example) J79CW

* Solid state auto switches marked with "○" are produced upon receipt of order.
** It is impossible to mount solid state switches to the housing mounting ø10.

• Since there are other applicable auto switches than listed, refer to page 703 for details.
• For details about auto switches with pre-wired connector, refer to pages 1192 and 1193.

CX2
CXW
CXT
CXSJ
CX5

D-□
-X□

CXWL Series

Built-in shock absorber

This is built-in shock absorber type in which the shock absorber is enclosed in the housing.

Dramatically reduced installation labor

The machining precision required for positioning during the installation of the cylinder has been reduced through the adoption of a special pin hole machining process, thus decreasing the amount of labor involved in adjustment.

High-precision ball bushing

The bearings made of ball bushings decrease the rise in starting pressure that could be caused by a load imbalance.

This also enables smooth operation by ensuring stable travel resistance.

Provided with an end lock mechanism

An end lock is also available, which maintains the cylinder's original position even if the air supply is interrupted.

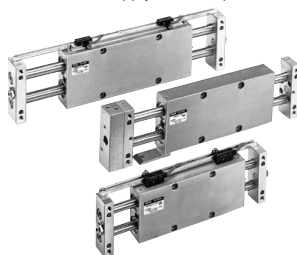

Made to Order: Individual Specifications
(For details, refer to pages 706 to 708.)

Symbol	Specifications
-X138	Adjustable stroke
-X146	Hollow piston rod
-X168	Helical insert thread
-X169	2 built-in magnets

Made to Order Specifications

[Click here for details](#)

Symbol	Specifications
-XB11	Long stroke type
-XB13	Low speed cylinder (5 to 50 mm/s)
-XC22	Fluororubber seal

Moisture Control Tube IDK Series



When operating an actuator with a small diameter and a short stroke at a high frequency, the dew condensation (water droplet) may occur inside the piping depending on the conditions.

Simply connecting the moisture control tube to the actuator will prevent dew condensation from occurring. For details, refer to [the IDK series in the Best Pneumatics No. 6](#).

Specifications

Type	Non-lube	
Fluid	Air	
Proof pressure	1.5 MPa	
Max. operating pressure	1.0 MPa	
Min. operating pressure	CXWL10/16	0.15 MPa
	CXWL20/25/32	0.10 MPa
Ambient & fluid temperature	-10 to 60°C (No freezing)	
Piston speed (Non-lube)	30 to 500 mm/s	
Cushion	Shock absorber	
Stroke adjustable range	Standard stroke: ±2 mm	
Accessory (Option)	Straight knock pin (2 pcs.), Adjusting bolt* (-X138)	

* -X138* has a stroke adjustable range of -12.5 mm on one side.

Maximum Load Weight/Non-rotating Accuracy/Maximum Holding Force

Model	CXWL10	CXWL16	CXWL20	CXWL25	CXWL32
Max. movable weight ⁽¹⁾	1 kg	4 kg	5 kg	7 kg	10 kg
Non-rotating accuracy ⁽²⁾ (Deflection of a piston rod is not included.)	± 0.09°	± 0.03°	± 0.03°	± 0.02°	± 0.01°
Max. holding force (End lock model)	39.2 N	98.1 N	147.1 N	245.2 N	392.3 N

Note 1) Place the center of gravity of the load and center of the slide unit close during operation. If they are placed far apart from each other, please consult with SMC.

Note 2) The factors are obtained under the conditions of a 25 strokes plate is pushed out.

Shock Absorber Specifications

Shock absorber ⁽¹⁾	RB0805-X552	RB1006-X552	RB1411 RB1411-X552
Applicable slide unit	CXWL10/16-□□	CXWL20/25-□□	CXWL32-□□
Maximum energy absorption (J)	0.98	3.92	14.7
Stroke absorption (mm)	5	6	11
Max. collision speed (m/sec)	0.05 to 5		
Max. operating frequency (cycle/min) ⁽²⁾	80	70	45
Max. allowable thrust (N)	147	353	667
Ambient temperature range (°C)	-10 to 80		
Spring force (N)	Extended	4.22	6.86
	Retracted	3.83	6.18
Weight (g)	15	25	65

Note 1) "-X552" is an exclusive shock absorber installed in the housing, and is the screw not attached specification of the outer part of the outer tube. "CXWL32-25" is mounted on a single side of the plate and of the screw attached specification.

Note 2) It denotes the values at the maximum energy absorption per one cycle. Therefore, the operating frequency can be increased according to the energy absorption.

* The shock absorber service life is different from that of the cylinder depending on the operating conditions. Refer to the RB series Specific Product Precautions for the replacement period.

Theoretical Output

(N)

Model	Rod size (mm)	Piston area (mm ²)	Operating pressure (MPa)								
			0.2	0.3	0.4	0.5	0.6	0.7	0.8	0.9	
CXWL10-□□	6	101	20	30	40	51	61	71	81	91	
CXWL16-□□	10	245	49	74	98	123	147	172	196	221	
CXWL20-□□	12	402	80	121	161	201	241	281	322	362	
CXWL25-□□	14	597	119	179	239	299	358	418	478	537	
CXWL32-□□	20	980	196	294	392	490	588	686	784	882	

Note) Theoretical output (N) = Pressure (MPa) x Piston area (mm²)

Standard Stroke

Model	Standard stroke (mm)							
	25	50	75	100	125	150	175	200
CXWL10-□□	●	●	●	●	—	—	—	—
CXWL16-□□	●	●	●	●	●	●	●	●
CXWL20-□□	●	●	●	●	●	●	●	●
CXWL25-□□	●	●	●	●	●	●	●	●
CXWL32-□□	(*)	●	●	●	●	●	●	●

Note) The strokes marked with "(*)" has an absorber of single side plate mounting type.

Slide Unit: Built-in Shock Absorber Ball Bushing Bearing Type **CXWL Series**

Weight

Model	Stroke (mm)							
	25	50	75	100	125	150	175	200
CXWL10	0.33	0.40	0.46	0.53	—	—	—	—
CXWL16	0.72	0.85	0.98	1.11	1.23	1.36	1.49	1.62
CXWL20	1.0	1.18	1.35	1.53	1.71	1.89	2.06	2.24
CXWL25	1.32	1.54	1.76	1.97	2.19	2.43	2.63	2.86
CXWL32	2.56	2.96	3.37	3.75	4.19	4.56	4.98	5.39

Additional Weight with End Lock (CXWL□-R)

Applicable model	Additional weight
CXWL10	0.08
CXWL16	0.14
CXWL20	0.15
CXWL25	0.20
CXWL32	0.43

Operating Direction with Different Pressure Ports

Operating direction of housing when the plate is fixed

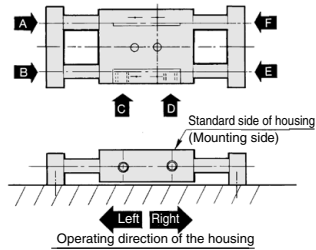

Pressure port	A	B	C	D	E	F
Operating direction	Right	Left	Left	Right	Left	Right

* There are 9 possible reciprocating piping methods.

With end lock (CXWL□-R)
Operating direction of housing when the plate is fixed

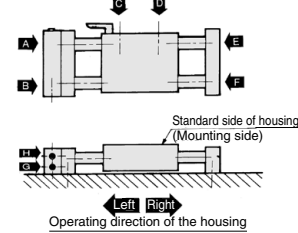

Pressure port	A	B	C	D	E	F	G	H
Operating direction	Right	Left	Left	Right	Right	Left	Left	Right

* There are 16 possible reciprocating piping methods.

Accessory Straight Knock Pin (Option)

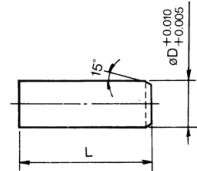

Model	L	øD	Model*
CXWL10	10	4	MS4-10
CXWL16	10	5	MS5-10
CXWL20	15	6	MS6-15
CXWL25	15	6	MS6-15
CXWL32	20	8	MS8-20

* Manufactured by Misumi Trading Ltd.

Deflection of Piston Rod by Center Loading (Reference)

When center loading is added to the center of the housing

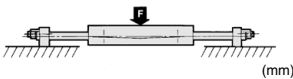

Model	Stroke	
	100	200
CXWL10	9.81	0.07
CXWL16	39.2	0.05
CXWL20	49	0.04
CXWL25	68.6	0.03
CXWL32	98.1	0.02

When center loading is added to the center of the plate

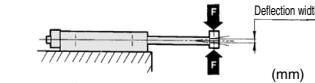

Model	Stroke			
	50	100	150	200
CXWL10	2.94	0.06	0.30	—
CXWL16	4.90	0.03	0.10	0.25
CXWL20	7.84	0.03	0.09	0.18
CXWL25	9.81	0.03	0.09	0.16
CXWL32	29.42	0.02	0.05	0.10

Note) The values denote the total width of the deflections in the upward/downward direction.

CX2

CXW

CXT

CXSJ

CXS

D-□

-X□

CXWL Series

Construction: $\varnothing 10$, $\varnothing 16$, $\varnothing 25$

CXWL10

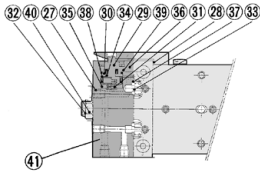

With end lock

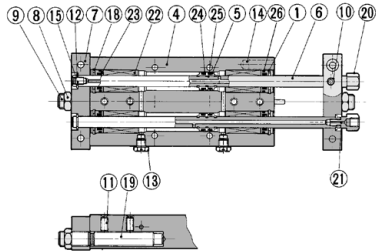

CXWL16

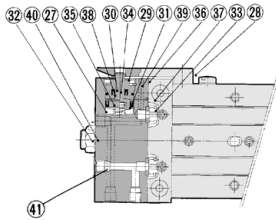

With end lock

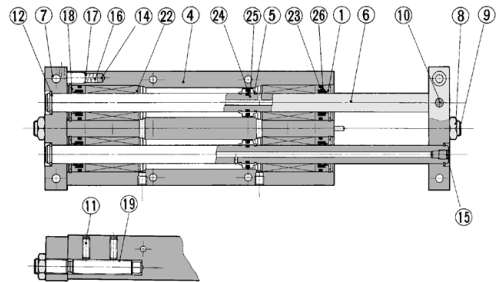

CXWL25

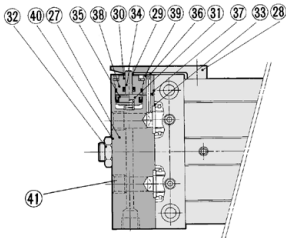

With end lock

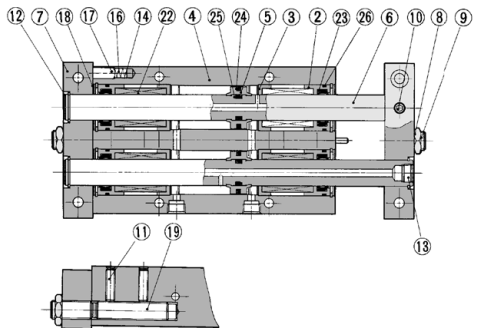

Construction: ø10, ø16, ø25

Component Parts

No.	Description	Material	Note
1	Rod cover	Aluminum alloy	Anodized
2	Rod cover A	Aluminum alloy	Anodized
3	Rod cover B	Aluminum alloy	Anodized
4	Housing	Aluminum alloy	Hard anodized
5	Piston	Aluminum alloy	Chromated
6	Piston rod	High carbonate chrome bearing steel pipe	Quenched, Hard chrome plated
7	Plate	Aluminum alloy	Hard anodized
8	Lock nut	Carbon steel	Nickel plated
9	Adjusting bolt	Chromium steel	Nickel plated
10	Set screw (For fixing rods)	Chromium steel	Nickel plated
11	Set screw (For fixing shock absorbers)	Stainless steel	
12	Retaining ring	Carbon tool steel	Phosphate coated
13	Plug	Brass	Nickel plated
14	Magnet	—	ø5
15	Set screw for seal	Chromium steel	Nickel plated
16	Spring	Stainless steel	
17	Type CR retaining ring	Carbon tool steel	
18	Round type R retaining ring	Carbon tool steel	Phosphate coated
19	Shock absorber	—	(RB0805-X552 or RB1006-X552)
20	Socket	Brass	Electroless nickel plated
21	Gasket	NBR	
22	Ball bushing	—	
23	Rod seal	NBR	
24	Piston seal	NBR	
25	Piston gasket	NBR	
26	Cylinder tube gasket	NBR	

**Replacement Parts: Seal Kit
Cylinder Body**

Model	Kit no.	Contents
CXWL10	CXWL10-PS	A set of 23, 24 and 26 listed above
CXWL16	CXWL16-PS	
CXWL25	CXWL25-PS	

- * Seal kit includes 23, 24 and 26. Order the seal kit with the part number for each model.
- * 25 is not replaceable.
- * Since the seal kit does not include a grease pack, order it separately.
Grease pack part no.: GR-S-010 (10 g)

Component Parts: With End Lock

No.	Description	Material	Note
27	Locking body	Aluminum alloy	Hard anodized
28	Lock finger	Alloy tool steel	Nickel plated after quenched
29	Lock piston	Carbon tool steel	Electroless nickel plated after quenched
30	Rod cover	Aluminum alloy	
31	Return spring	Spring steel	Zinc chromated
32	Adjusting bolt	Chromium steel	Nickel plated
33	Body gasket	NBR	
34	Rod seal	NBR	
35	Piston seal	NBR	
36	Steel ball	High carbon chrome bearing steel	
37	Steel ball	High carbon chrome bearing steel	
38	O-ring	NBR	
39	Round type R retaining ring	Carbon tool steel	Phosphate coated
40	Lock nut	Carbon steel	Nickel plated
41	Plug	Chromium steel	Nickel plated

**Replacement Parts: Seal Kit
End Lock**

Model	Kit no.	Contents
CXWL10	CXWL10R-PS	A set of 33, 34, 35 and 38 listed above
CXWL16	CXWL16R-PS	
CXWL25	CXWL25R-PS	

- * Seal kit includes 33, 34, 35 and 38. Order the seal kit with the part number for each model.
- * Since the seal kit does not include a grease pack, order it separately.
Grease pack part no.: GR-S-010 (10 g)

CX2
CXW
CXT
CXSJ
CXS

D-□
-X□

CXWL Series

Construction: $\varnothing 20, \varnothing 32$

CXWL20

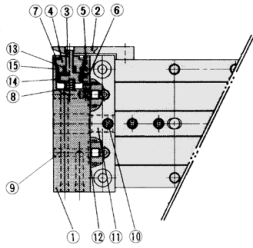

With end lock

CXWL32

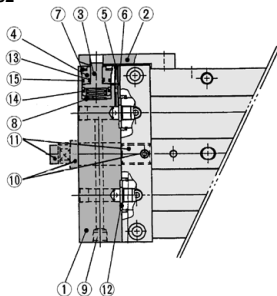

With end lock

Component Parts

No.	Description	Material	Note
1	Rod cover	Aluminum alloy	Anodized
2	Rod cover A	Aluminum alloy	Anodized
3	Rod cover B	Aluminum alloy	Anodized
4	Housing	Aluminum alloy	Hard anodized
5	Piston	Aluminum alloy	Chromated
6	Piston rod	High carbon chrome bearing steel	—
7	Plate	Aluminum alloy	Hard anodized
8	Adjustment bolt	Chromium steel	Nickel plated
9	Hex. socket head set screw	Chromium steel	Nickel plated
10	Hex. socket head set screw	Chromium steel	Nickel plated
11	Retaining ring	Tool steel	Phosphate coated
12	Magnet	—	$\varnothing 5$
13	Spring	Stainless steel	—
14	Type CR retaining ring	Carbon tool steel	—
15	Round type R retaining ring	Carbon tool steel	Phosphate coated
16	Ball bushing	—	—
17	Shock absorber	—	RB1006-X552 or RB1411-X552
18	Plug	Chromium steel	Nickel plated
19	Hex. socket head set screw	Stainless steel	—
21	Piston seal	NBR	—
22	Rod seal	NBR	—
23	Piston gasket	NBR	—
24	Cylinder tube gasket	NBR	—

Replacement Parts: Seal Kit Cylinder Body

Model	Kit no.	Contents
CXWL20	CXWL20-PS	A set of 21, 22 and 23 listed above
CXWL32	CXWL32-PS	

- * Seal kit includes 21, 22 and 23. Order the seal kit with the part number for each model.
- * 23 is not replaceable.
- * Since the seal kit does not include a grease pack, order it separately.
Grease pack part no.: GR-S-010 (10 g)

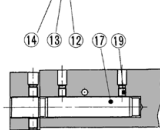
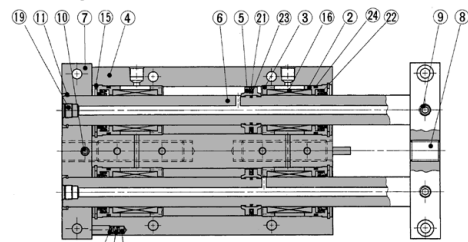
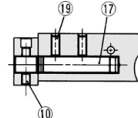
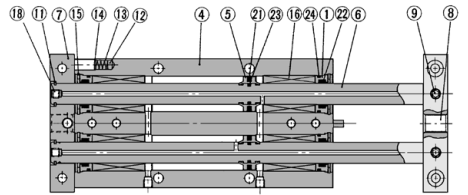

Component Parts: With End Lock

No.	Description	Material	Note
1	Locking body	Aluminum alloy	Hard anodized
2	Lock finger	Alloy tool steel	Nickel plating after quenched
3	Lock piston	Tool steel	Electroless nickel plated after quenched
4	Rod cover	Aluminum bearing alloy	—
5	Steel ball	High carbon chrome bearing steel	—
6	Steel ball	High carbon chrome bearing steel	—
7	Round type R retaining ring	Carbon tool steel	Phosphate coated
8	Return spring	Spring steel	Zinc chromated
9	Plug	Chromium steel	Nickel plated
Note 10	25, (50) to 200 ST Hexagon socket head set screw	Chromium steel	Nickel plated
	(25) ST Hexagon nut	Carbon steel	Nickel plated
Note 11	25, (50) to 200 ST Adjustment bolt	Chromium steel	Nickel plated
	(25) ST Shock absorber	—	RB1411
12	Body gasket	NBR	—
13	Rod seal	NBR	—
14	Piston seal	NBR	—
15	O-ring	NBR	—

Note) Figures in parentheses denote the case of CXWM32.

Replacement Parts: Seal Kit End Lock

Model	Kit no.	Contents
CXWL20	CXWL20R-PS	A set of 12, 13, 14 and 15 listed above
CXWL32	CXWL32R-PS	

- * Seal kit includes 12, 13, 14 and 15. Order the seal kit with the part number for each model.
- * Since the seal kit does not include a grease pack, order it separately.
Grease pack part no.: GR-S-010 (10 g)

Slide Unit: Built-in Shock Absorber Ball Bushing Bearing Type **CXWL Series**

ø10 Basic Type: CXWL10-Stroke/25 to 100

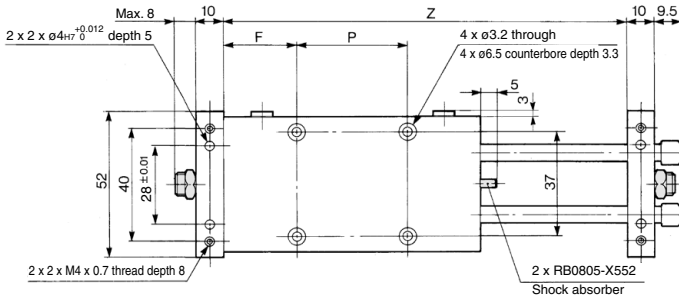
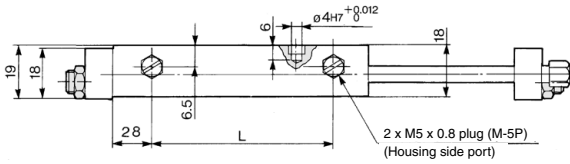
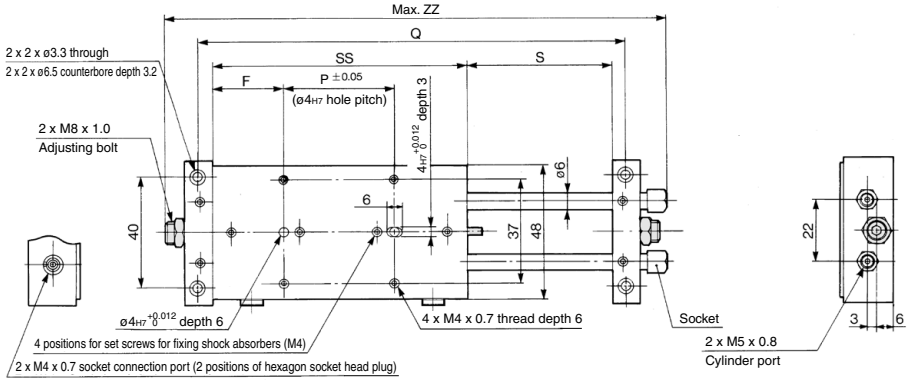

Model	F	L	P	Q	S	SS	Z	ZZ
CXWL10-25	35.5	45	30	138	27	101	128	165.5
CXWL10-50	38	70	50	188	52	126	178	215.5
CXWL10-75	40.5	95	70	238	77	151	228	265.5
CXWL10-100	43	120	90	288	102	176	278	315.5

CX2

CXW

CXT

CXSJ

CXS

D-□

-X□

CXWL Series

ø10 With End Lock: CXWL10-Stroke/25 to 100R

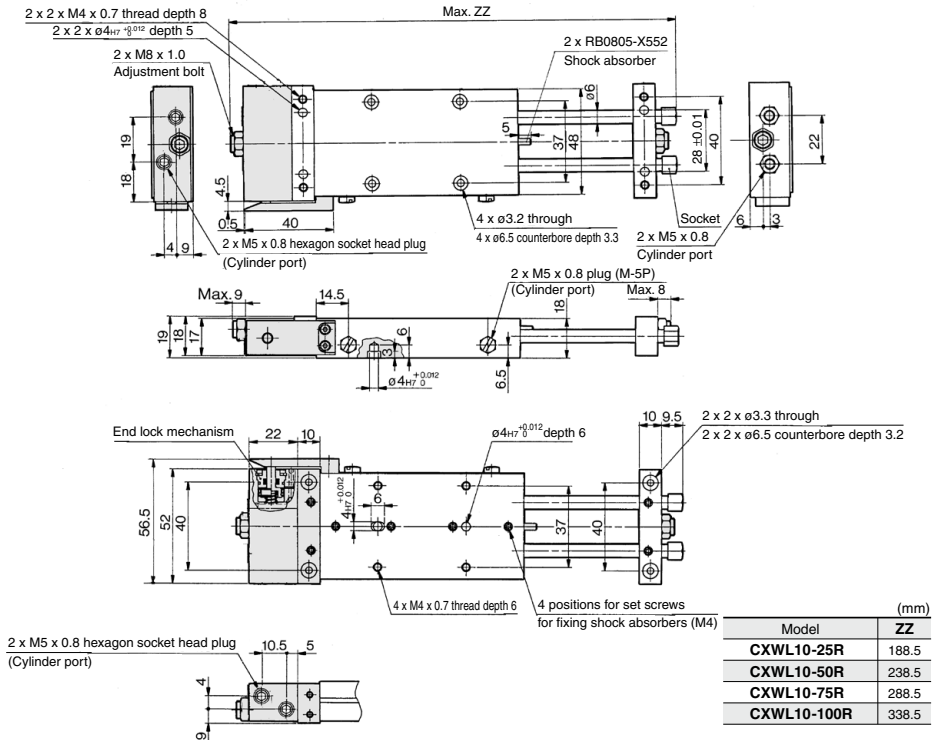

Housing mounting type with auto switch CDBXWL10-Stroke, CDBXWL10-Stroke R

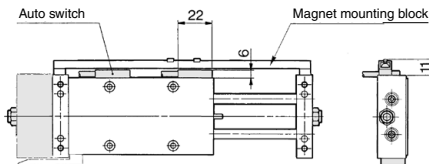

- Note 1) The figure above is for D-E7□A/E80A.
 Note 2) For only 25 stroke, 2 magnets for auto switches are equipped with the magnet mounting block.

Plate mounting type with auto switch CDPXWL10-Stroke, CDPXWL10-Stroke R

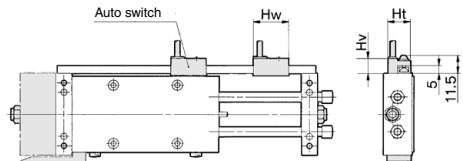

Note 1) The dimensions show D-A7 and D-A8. (mm)

Auto switch model	Hw	Ht	Hv
D-A7□, D-A80	23	15	10.5
D-F7□, D-J79, D-J79W, D-F7□W, D-F79F, D-F7BA, D-F7NT	23	15	10
D-A7□H, D-A80H	22	15	9
D-A73C, D-A80C	23	17.5	17.5
D-F7□V, D-F7□WV, D-F7BAV	23	15	14
D-J79C	24	17.5	16

Note 2) For only 25 stroke, 2 magnets for auto switches are installed in the housing.

Slide Unit: Built-in Shock Absorber Ball Bushing Bearing Type **CXWL Series**

ø16 Basic Type: CXWL16-Stroke/25 to 200

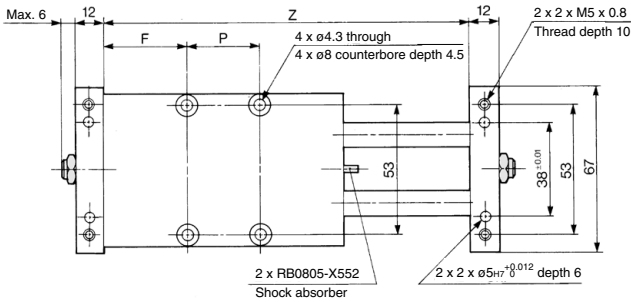
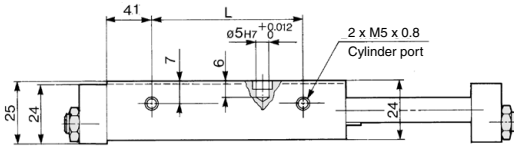
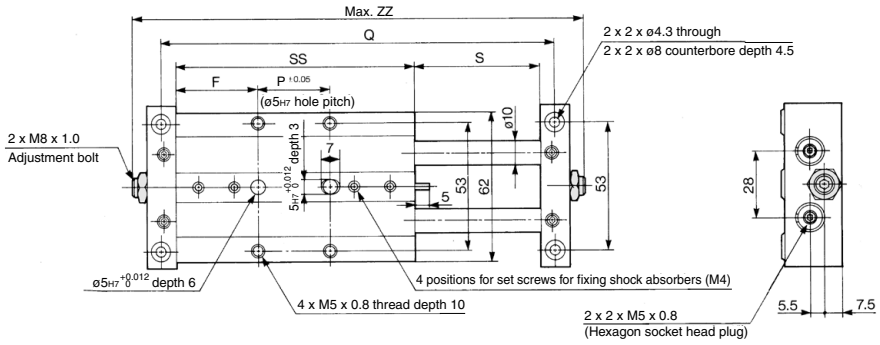

Model	F	L	P	Q	S	SS	Z	ZZ
CXWL16-25	34.5	39	52	160	27	121	148	184
CXWL16-50	47	64	52	210	52	146	198	234
CXWL16-75	53	89	65	260	77	171	248	284
CXWL16-100	53	114	90	310	102	196	298	334
CXWL16-125	65.5	139	90	360	127	221	348	384
CXWL16-150	78	164	90	410	152	246	398	434
CXWL16-175	90.5	189	90	460	177	271	448	484
CXWL16-200	103	214	90	510	202	296	498	534

(mm)

- CX2**
- CXW**
- CXT**
- CXSJ**
- CXS**

- D-□**
- X□**

CXWL Series

ø16 With End Lock: CXWL16-Stroke/25 to 200 R

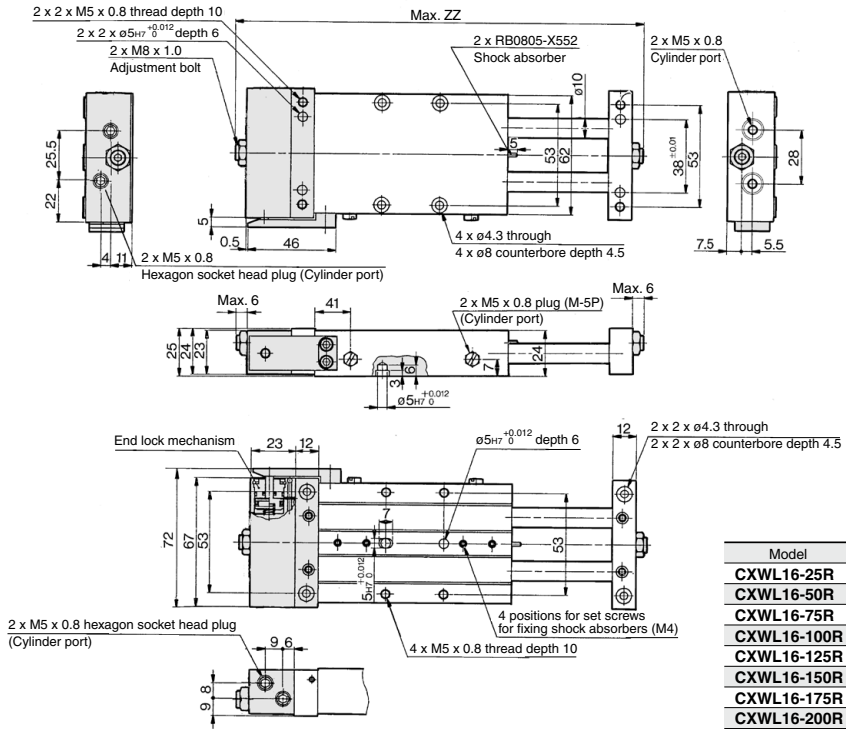

Housing mounting type with auto switch CDBXWL16-Stroke, CDBXWL16-Stroke R

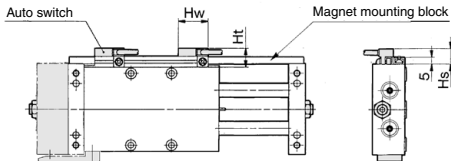

Note 1) The dimensions show D-A7 and D-A8. (mm)

Auto switch model	Hw	Hs	Ht
D-A7□, D-A80	23	12.5	15
D-F7□, D-J79, D-J79W, D-F7□W, D-F79F, D-F7BA, D-F7NT	23	12.5	15
D-A7□H, D-A80H	22	12.5	15
D-A73C, D-A80C	23	15	17.5
D-F7□V, D-F7□WV, D-F7BAV	23	12.5	15
D-J79C	24	15	17.5
D-F7LF	30	12.5	15

Note 2) For only 25 stroke, 2 magnets for auto switches are equipped with the magnet mounting block.

Plate mounting type with auto switch CDPXWL16-Stroke, CDPXWL16-Stroke R

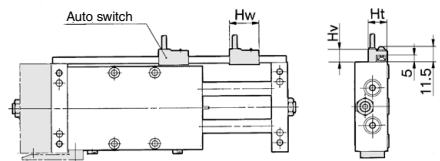

Note 1) The dimensions show D-A7 and D-A8. (mm)

Auto switch model	Hw	Ht	Hv
D-A7□, D-A80	23	15	10.5
D-F7□, D-J79, D-J79W, D-F7□W, D-F79F, D-F7BA, D-F7NT	23	15	10
D-A7□H, D-A80H	22	15	9
D-A73C, D-A80C	23	17.5	17.5
D-F7□V, D-F7□WV, D-F7BAV	23	15	14
D-J79C	24	17.5	16

Note 2) For only 25 stroke, 2 magnets for auto switches are installed in the housing.

Slide Unit: Built-in Shock Absorber Ball Bushing Bearing Type **CXWL Series**

ø20 Basic Type: CXWL20- Stroke/25 to 200

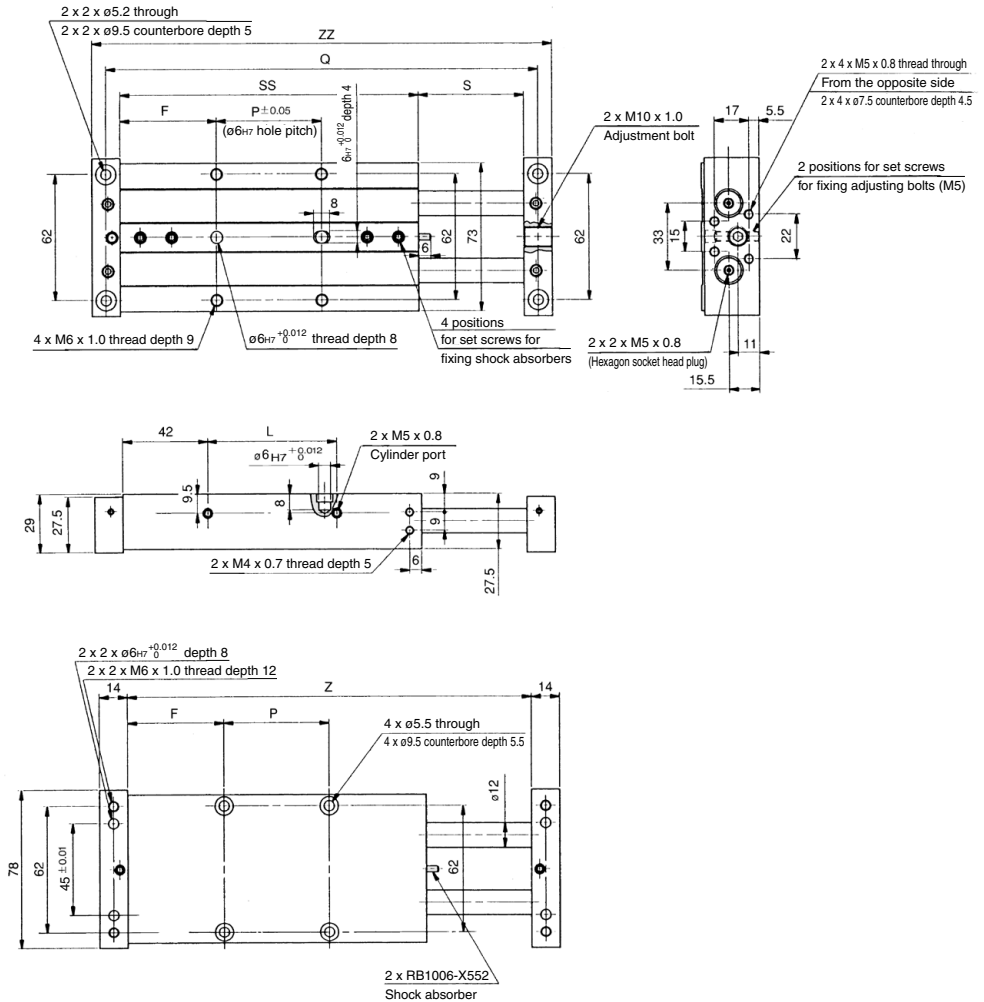

	(mm)							
Model	F	L	P	Q	S	SS	Z	ZZ
CXWL20-25	35.5	39	52	164	27	123	150	178
CXWL20-50	48	64	52	214	52	148	200	228
CXWL20-75	56.5	89	60	264	77	173	250	278
CXWL20-100	54	114	90	314	102	198	300	328
CXWL20-125	66.5	139	90	364	127	223	350	378
CXWL20-150	79	164	90	414	152	248	400	428
CXWL20-175	91.5	189	90	464	177	273	450	478
CXWL20-200	104	214	90	514	202	298	500	528

CX2

CXW

CXT

CXSJ

CXS

D-□

-X□

CXWL Series

ø20 With End Lock: CXWL20-Stroke/25 to 200 R

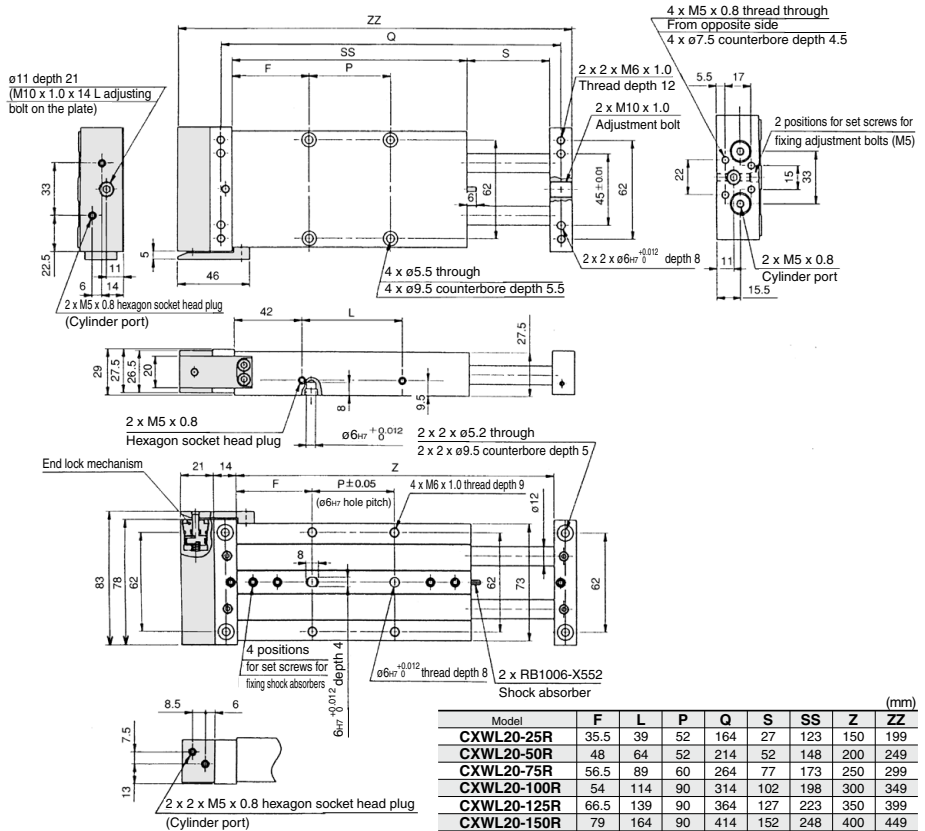

Model	F	L	P	Q	S	SS	Z	ZZ
CXWL20-25R	35.5	39	52	164	27	123	150	199
CXWL20-50R	48	64	52	214	52	148	200	249
CXWL20-75R	56.5	89	60	264	77	173	250	299
CXWL20-100R	54	114	90	314	102	198	300	349
CXWL20-125R	66.5	139	90	364	127	223	350	399
CXWL20-150R	79	164	90	414	152	248	400	449
CXWL20-175R	91.5	189	90	464	177	273	450	499
CXWL20-200R	104	214	90	514	202	298	500	549

Housing mounting type with auto switch CDBXWL20-Stroke, CDBXWL20-Stroke R

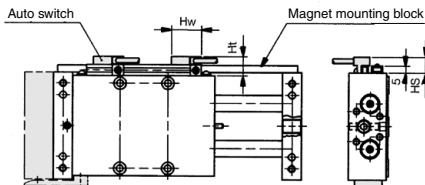

Note 1) The dimensions show D-A7 and D-A8. (mm)

Auto switch model	Hw	Hs	Ht
D-A7□, D-A80	23	12.5	15
D-F7□, D-J79, D-J79W, D-F7□W, D-F79F, D-F7BA, D-F7NT	23	12.5	15
D-A7□H, D-A80H	22	12.5	15
D-A73C, D-A80C	23	15	17.5
D-F7□V, D-F7□WV, D-F7BAV	23	12.5	15
D-J79C	24	15	17.5
D-7LF	30	12.5	15

Note 2) For 25 stroke, 2 magnets for auto switches are equipped to the magnet mounting block.

Plate mounting type with auto switch CDPXWL20-Stroke, CDPXWL20-Stroke R

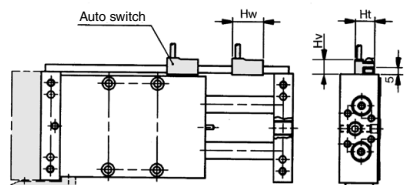

Note 1) The dimensions show D-A7 and D-A8. (mm)

Auto switch model	Hw	Ht	Hv
D-A7□, D-A80	23	15	10.5
D-F7□, D-J79, D-J79W, D-F7□W, D-F79F, D-F7BA, D-F7NT	23	15	10
D-A7□H, D-A80H	22	15	9
D-A73C, D-A80C	23	17.5	17.5
D-F7□V, D-F7□WV, D-F7BAV	23	15	14
D-J79C	24	17.5	16

Note 2) For 25 stroke, 2 magnets for auto switches are installed in the housing.

Slide Unit: Built-in Shock Absorber Ball Bushing Bearing Type **CXWL Series**

ø25 Basic Type: CXWL25- Stroke/25 to 200

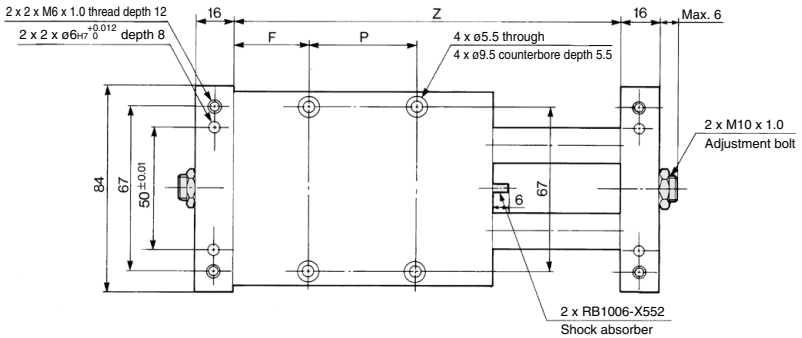
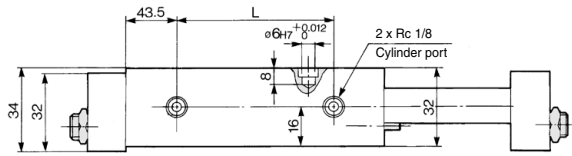
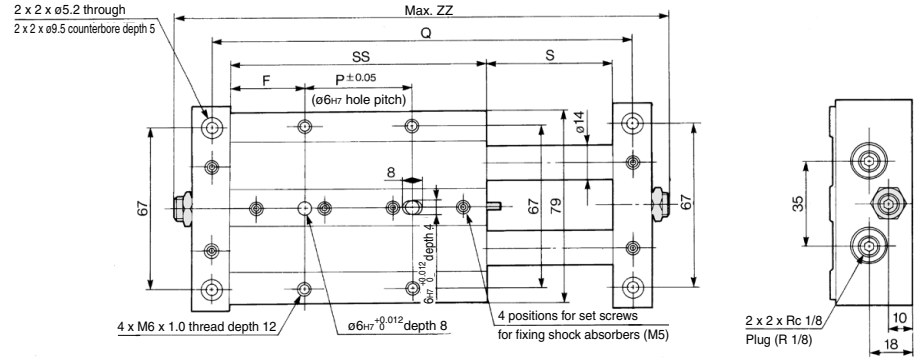

Model	F	L	P	Q	S	SS	Z	ZZ
CXWL25-25	31.5	41	65	171	27	128	155	199
CXWL25-50	31.5	66	90	221	52	153	205	249
CXWL25-75	56.5	91	65	271	77	178	255	299
CXWL25-100	56.5	116	90	321	102	203	305	349
CXWL25-125	69	141	90	371	127	228	355	399
CXWL25-150	81.5	166	90	421	152	253	405	449
CXWL25-175	94	191	90	471	177	278	455	499
CXWL25-200	106.5	216	90	521	202	303	505	549

(mm)

- CX2**
- CXW**
- CXT**
- CXSJ**
- CXS**

- D
- X

CXWL Series

ø25 With End Lock: CXWL25-Stroke/25 to 200R

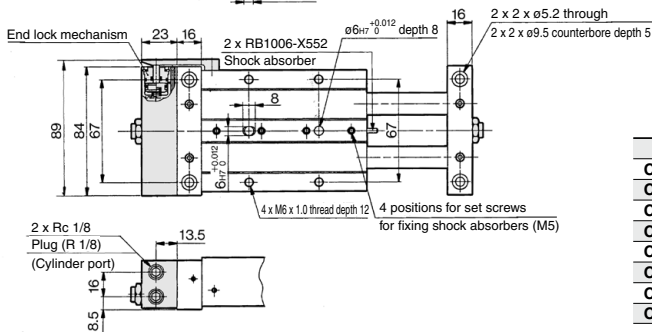
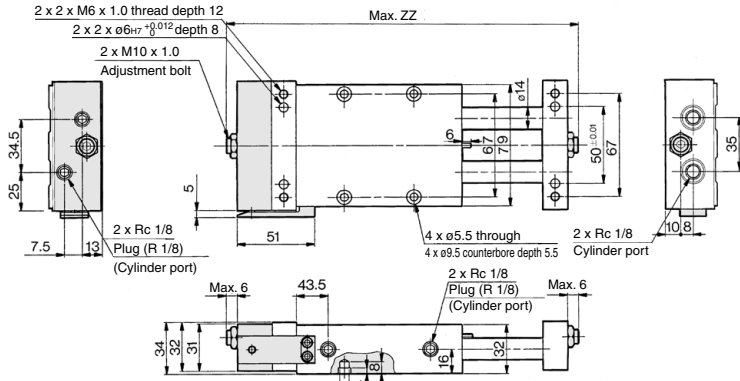

Model	ZZ (mm)
CXWL25-25R	222
CXWL25-50R	272
CXWL25-75R	322
CXWL25-100R	372
CXWL25-125R	422
CXWL25-150R	472
CXWL25-175R	522
CXWL25-200R	572

Housing mounting type with auto switch CDBXL25-Stroke, CDBXL25-StrokeR

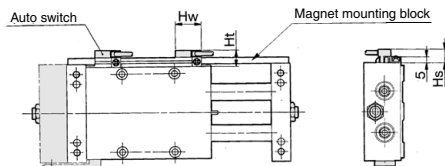

Note 1) The dimensions show D-A7 and D-A8. (mm)

Auto switch model	Hw	Hs	Ht
D-A7□, D-A80	23	12.5	15
D-F7□, D-J79, D-J79W, D-F7□W, D-F79F, D-F7BA, D-F7NT	23	12.5	15
D-A7□H, D-A80H	22	12.5	15
D-A73C, D-A80C	23	15	17.5
D-F7□V, D-F7□WV, D-F7BAV	23	12.5	15
D-J79C	24	15	17.5
D-F7LF	30	12.5	15

Note 2) For only 25 stroke, 2 magnets for auto switches are equipped to the magnet mounting block.

Plate mounting type with auto switch CDPXL25-Stroke, CDPXL25-StrokeR

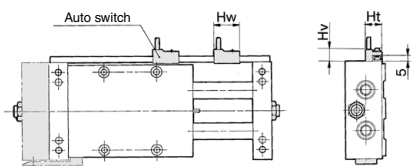

Note 1) The dimensions show D-A7 and D-A8. (mm)

Auto switch model	Hw	Ht	Hv
D-A7□, D-A80	23	15	10.5
D-F7□, D-J79, D-J79W, D-F7□W, D-F79F, D-F7BA, D-F7NT	23	15	10
D-A7□H, D-A80H	22	15	9
D-A73C, D-A80C	23	17.5	17.5
D-F7□V, D-F7□WV, D-F7BAV	23	15	14
D-J79C	24	17.5	16

Note 2) For only 25 stroke, 2 magnets for auto switches are built into the housing.

Slide Unit: Built-in Shock Absorber Ball Bushing Bearing Type **CXWL Series**

ø32 Basic Type: CXWL32-Stroke/50 to 200

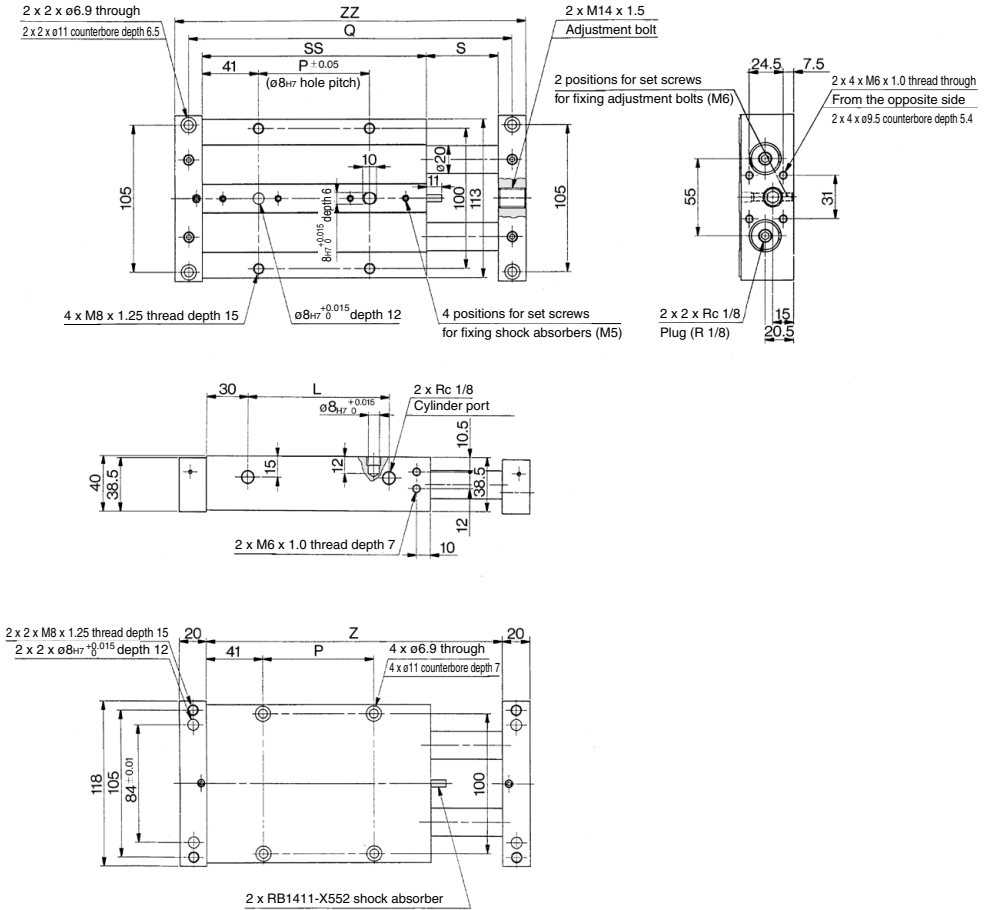

(mm)

Model	L	P	Q	S	SS	Z	ZZ
CXWL32-50	102	80	234	52	162	214	254
CXWL32-75	127	105	284	77	187	264	304
CXWL32-100	152	130	334	102	212	314	354
CXWL32-125	177	155	384	127	237	364	404
CXWL32-150	202	180	434	152	262	414	454
CXWL32-175	227	205	484	177	287	464	504
CXWL32-200	252	230	534	202	312	514	554

CX2

CXW

CXT

CXSJ

CXS

D-□

-X□

CXWL Series

ø32 Basic Type: CXWL32-25 stroke

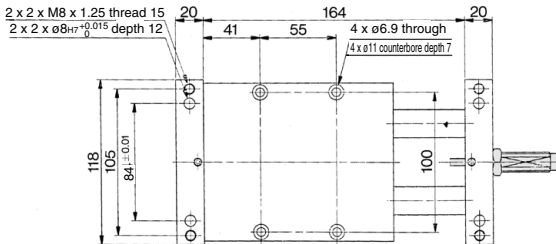
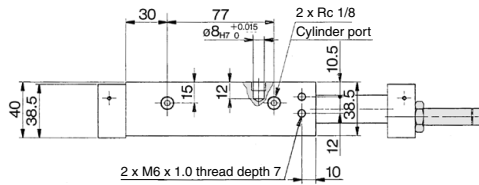
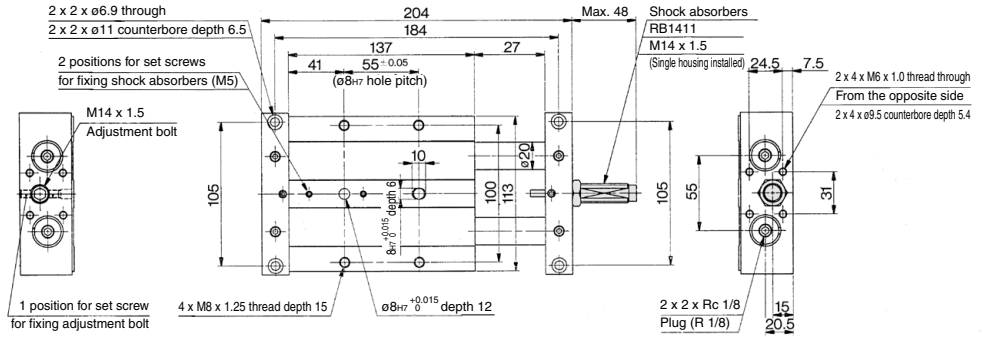

ø32 With End Lock: CXWL32-Stroke/50 to 200R

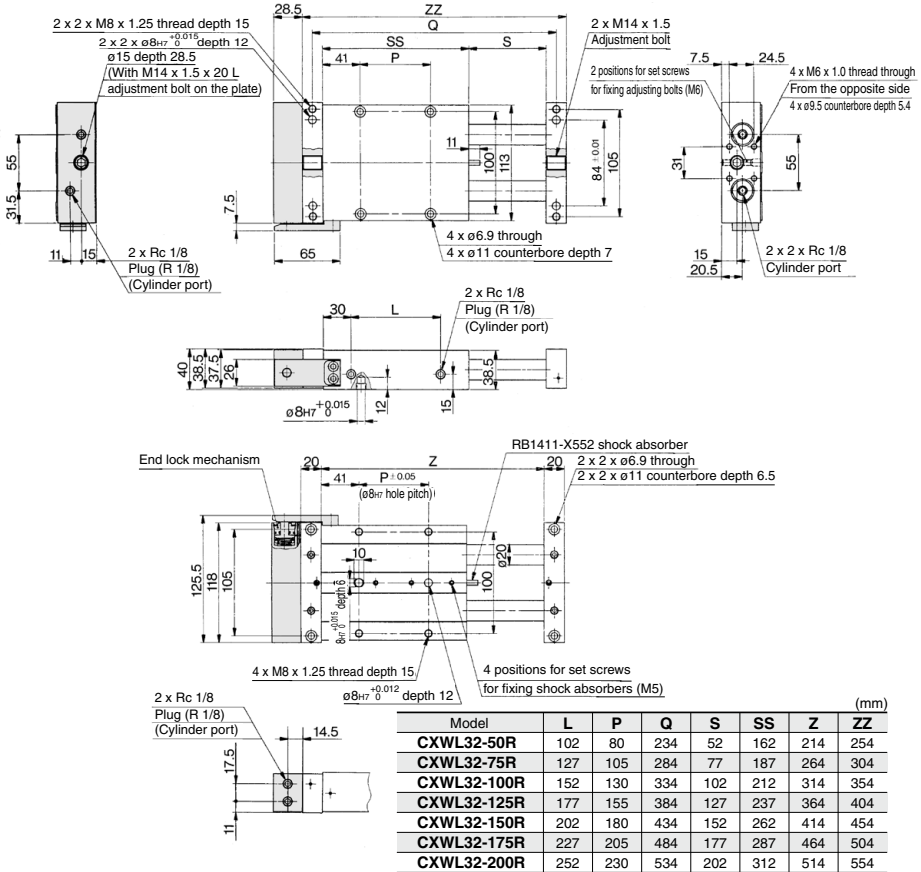

Housing mounting type with auto switch
CDBXL32-Stroke, CDBXL32-Stroke R

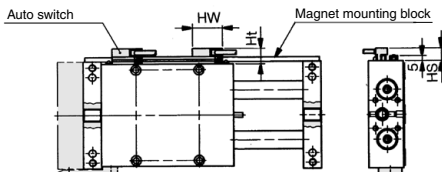

Note 1) The dimensions show D-A7 and D-A8. (mm)

Auto switch model	Hw	Hs	Ht
D-A7□, D-A80	23	12.5	15
D-F7□, D-J79, D-J79W, D-F7□W, D-F79F, D-F7BA, D-F7NT	23	12.5	15
D-A7□H, D-A80H	22	12.5	15
D-A73C, D-A80C	23	15	17.5
D-F7□V, D-F7□WV, D-F7BAV	23	12.5	15
D-J79C	24	15	17.5
D-J79F	30	12.5	15

Note 2) For 25 stroke, the shock absorber is mounted on a single side of the plate. For dimensions of 25 stroke, refer to page 702.

Plate mounting type with auto switch
CDPXL32-Stroke, CDPXL32-Stroke R

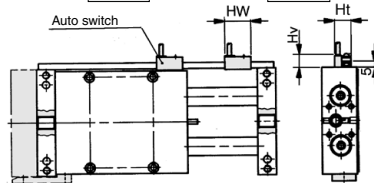

Note 1) The dimensions show D-A7 and D-A8. (mm)

Auto switch model	Hw	Ht	Hv
D-A7□, D-A80	23	15	10.5
D-F7□, D-J79, D-J79W, D-F7□W, D-F79F, D-F7BA, D-F7NT	23	15	10
D-A7□H, D-A80H	22	15	9
D-A73C, D-A80C	23	17.5	17.5
D-F7□V, D-F7□WV, D-F7BAV	23	15	14
D-J79C	24	17.5	16

Note 2) For 25 stroke, the shock absorber is mounted on a single side of the plate. For dimensions of 25 stroke, refer to page 702.

CX2

CXW

CXT

CXSJ

CXS

D-□

-X□

CXWL Series

ø32 With End Lock: CXWL32-25 stroke R

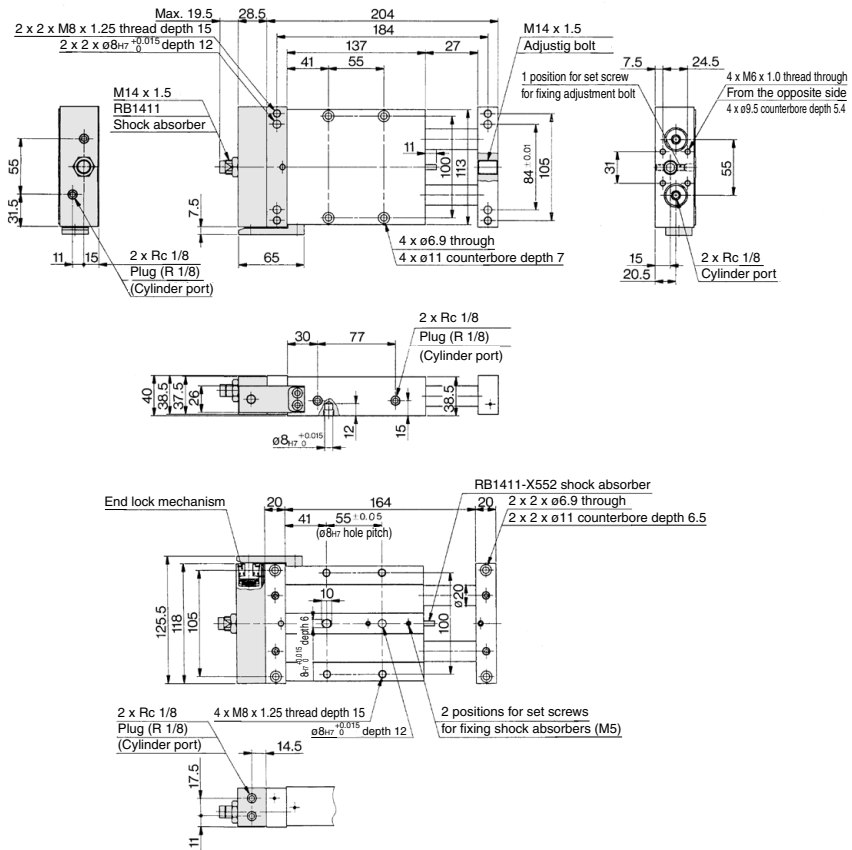

Housing mounting type with auto switch CDBXL32-25, CDBXL32-25R

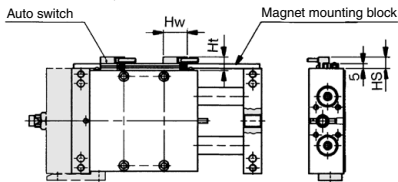

Note 1) The dimensions show D-A7 and D-A8. (mm)

Auto switch model	Hw	Hs	Ht
D-A7□, D-A80	23	12.5	15
D-F7□, D-J79, D-J79W, D-F7□W, D-F79F, D-F7BA, D-F7NT	23	12.5	15
D-A7□H, D-A80H	22	12.5	15
D-A73C, D-A80C	23	15	17.5
D-F7□V, D-F7□WV, D-F7BAV	23	12.5	15
D-J79C	24	15	17.5
D-F7LF	30	12.5	15

Note 2) 2 magnets for auto switches are equipped to the magnet mounting block.

Plate mounting type with auto switch CDPXL32-25, CDPXL32-25R

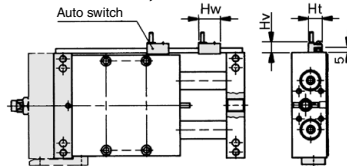

Note 1) The dimensions show D-A7 and D-A8. (mm)

Auto switch model	Hw	Ht	Hv
D-A7□, D-A80	23	15	10.5
D-F7□, D-J79, D-J79W, D-F7□W, D-F79F, D-F7BA, D-F7NT	23	15	10
D-A7□H, D-A80H	22	15	9
D-A73C, D-A80C	23	17.5	17.5
D-F7□V, D-F7□WV, D-F7BAV	23	15	14
D-J79C	24	17.5	16

Note 2) 2 magnets for auto switches are installed in the housing.

Operating Range

(mm)

Auto switch model		Applicable cylinder size				
		10	16	20	25	32
D-A7□/A80 D-A7□H/A80H D-A73C/A80C	Housing mounting	—	6	6	6	6
	Plate mounting	6				
D-E7□A/E80A	Housing mounting	6	—	—	—	—
D-F7□/J79 D-F7□V/J79C D-F7□W/F7□WV D-F7BA/F7BAV D-F79F/F7NT	Housing mounting	—	4	2.5	3	3
	Plate mounting	3	3		2.5	2.5

* Since this is a guideline including hysteresis, not meant to be guaranteed.
(Assuming approximately ±30% dispersion)
There may be the case it will vary substantially depending on an ambient environment.

Other than the applicable auto switches listed in "How to Order", the following auto switches can be mounted.
For detailed specifications, refer to pages 1119 to 1245.

Auto switch type	Model	Electrical entry (Fetching direction)	Features	Applicable cylinder size	
				Housing mounting	Plate mounting
Solid state	D-F7NT	Grommet (In-line)	With timer	ø16, ø20 ø25, ø32	ø10, ø16 ø20, ø25 ø32

* With pre-wire connector is available for D-F7NT type, too. For details, refer to pages 1192 and 1193.
* It is impossible to mount solid state auto switches to the housing mounting ø10.

CX2

CXW

CXT

CXSJ

CXS

D-□

-X□



CXW Series

Specific Product Precautions 1

Be sure to read this before handling the products. Refer to back page 50 for Safety Instructions and pages 3 to 12 for Actuator and Auto Switch Precautions.

⚠ Warning

1. Take precautions to prevent your fingers or hands from getting caught between the plate and the housing.
 - Take sufficient care to avoid getting your hands or fingers caught when the cylinder is operated.

⚠ Caution

1. Make sure that the cylinder mounting surface is flat (a flatness of 0.05 or less {reference value}). If it is not flat, it could lead to malfunction.
2. Make sure not to scratch or gouge the cylinder mounting surface. Be aware that if the flatness of the housing mounting surface or the mounting surface of the plates on both sides is affected, it could lead to a malfunction.
3. Be careful not to twist the two piston rods. If the piston rods are twisted or bent when mounting the housing, the operating resistance could become abnormally high or the bearings could wear prematurely, leading to reduced accuracy or air leakage.
4. Consider reinforcing the plates. When the cylinder is mounted on the housing, and the plates are used for high-speed operation or used as a pusher, use a connector plate to bridge both plates. Failure to do so could cause the snap ring to become detached or the set screws to shift, causing the plates to fall off.

Recommended Pneumatic Circuit

⚠ Caution

1. This is necessary for the proper operation and release of the lock for cylinders with an end lock.

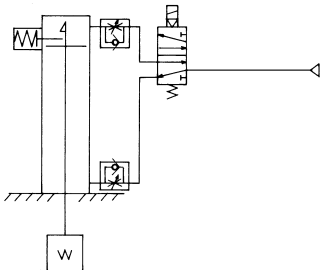

Precautions for Handling the End Lock Mechanism

⚠ Caution

1. Do not use 3 position solenoid valves. Avoid using this cylinder in combination with a 3 position solenoid valve (particularly the closed center metal seal type). If air pressure becomes sealed inside the port of the side that contains the lock mechanism, the lock will not engage. Even if the lock is engaged at first, the air that leaks from the solenoid valve could enter the cylinder and cause the lock to disengage as time elapses.
2. Back pressure is required to release the end lock. Be sure that air is supplied to the cylinder side without the locking mechanism (For cylinders with a double lock, the side with an unlocked piston rod) before starting operating, as shown in the drawing on the left. The lock may not be released. (Refer to the section on releasing the lock.)
3. Disengage the lock before installing or adjusting the cylinder. The lock could become damaged if the cylinder is installed with its lock engaged.
4. Operate with a load ratio of 50% or less. If the load ratio exceeds 50%, this may cause problems such as failure of the lock to release, or damage to the lock unit.
5. Do not operate multiple cylinders in synchronization. Avoid applications in which two or more end lock cylinders are synchronized to move one workpiece, as one of the cylinder locks may not be able to release when required.
6. Use a speed controller with meter-out control. Lock cannot be released occasionally by meter-in control.
7. Adjust the stroke within the range of the slotted hole of the lock finger. As the hole for mounting the lock finger is slotted, the lock finger may be adjusted and mounted in accordance with the adjustment amount of the adjusting bolt. The adjustment amount of the adjusting bolt is ± 2 mm (± 1 mm for each side).
8. Regarding manual disengagement Insert a Phillips screwdriver through the lock finger hole to push the lock piston down and slide it in the unlocking direction. When doing so, take precautions to prevent your fingers or hands from getting caught between the housing plate and the lock.

Operating Pressure

⚠ Caution

1. Apply a pressure more than the minimum operating pressure to the port on the side where the locking mechanism activates. The pressure is necessary to release the lock.

Releasing the Lock

⚠ Warning

1. Before releasing the lock, be sure to supply air to the side without the lock mechanism, so that there is no load applied to the lock mechanism when it is released. (Refer to the recommended pneumatic circuit.) If the lock is released when the port on the other side is in an exhaust state, and with a load applied to the lock unit, the lock unit may be subjected to an excessive force and be damaged. Furthermore, sudden movement of the piston rod is extremely dangerous.



CXW Series

Specific Product Precautions 2

Be sure to read this before handling the products. Refer to back page 50 for Safety Instructions and pages 3 to 12 for Actuator and Auto Switch Precautions.

Handling on Shock Absorber

⚠ Caution

1. Use caution not to be exposed to cutting oil, water, or dust, etc.

The RB series cannot be used under conditions in which fluids such as cutting oil or water are present in atomized form or come in direct contact with the piston rod, or in which dust could adhere to the piston rod. Such conditions would cause malfunction.

2. Do not operate the shock absorber in an environment that poses the risk of corrosion.

The shock absorber could rust if used in an environment that poses the risk of corrosion.

Refer to the respective construction for type of material that is used in the shock absorber.

3. Abide by the table below for the tightening torque for a mounting nut.

Shock absorber model	RB0805	RB1006	RB1411
Applicable slide unit	CXWM ₁₀ -25	CXWM ₂₀ -25	CXWM32-25, 50 CXWL32-25
Thread O.D. (mm)	M8 x 1.0	M10 x 1.0	M14 x 1.5
Thread prepared hole size (mm)	ø7.1 ^{+0.1}	ø9.1 ^{+0.1}	ø12.7 ^{+0.1}
Tightening torque (N·m)	1.67	3.14	10.8

4. Do not scratch the sliding portion of the piston rod or the outside threads of the outer tube.

Do not scratch or gouge the sliding portion of the piston rod or the outside threads of the outer tube by striking it with an object, squeezing it, or by forcefully wedging a set screw in it. Failure to observe this precaution could damage the seals, which could lead to oil leakage and malfunction. Furthermore, scratches or gouges on the outside threads of the outer tube could prevent the shock absorber from being mounted onto the frame, or its internal components could deform, leading to a malfunction.

5. Never turn the screw on the bottom of the body.

(This is not an adjusting screw.)

Turning it could cause oil leakage.

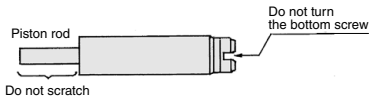

6. Check the mounting nut is not loosen.

The shock absorber could become damaged if it is used in a loose state.

7. Pay attention to any abnormal impact sounds or vibrations.

If the impact sounds or vibrations have become abnormally high, the shock absorber may have reached the end of its service life. If this is the case, replace the shock absorber.

If use is continued in this state, it could damage the equipment to which the shock absorber is mounted.

8. Refer to the Operation Manual for how to replace the built-in shock absorber for the CXW series.

Service Life and Replacement Period of Shock Absorber

⚠ Caution

1. Allowable operating cycle under the specifications set in this catalog is shown below.

1.2 million cycles RB08□□

2 million cycles RB10□□ to RB2725

Note) Specified service life (suitable replacement period) is the value at room temperature (20 to 25°C). The period may vary depending on the temperature and other conditions. In some cases the absorber may need to be replaced before the allowable operating cycle above.

Auto Switch Selection for the Adjustable Stroke Type (-X138)

⚠ Caution

1. When 50 stroke is adjusted to 40 stroke or less with the adjustable stroke type (-X138), auto switches may not be able to be mounted properly since they interfere with each other if the 2 in-line entry auto switches are used.

When strokes are adjusted to 40 stroke or less, select the perpendicular entry type or additionally select auto switches with 2 built-in magnets (-X169).

CX2

CXW

CXT

CXSJ

CXS

D-□

-X□

CX2/CXW Series

Made to Order: Individual Specifications 1

Please contact SMC for detailed dimensions, specifications and lead times.



Applicable Series

No.	Symbol	Specifications/Description	Slide bearing		Ball bushing bearing	No.	Symbol	Specifications/Description	Slide bearing		Ball bushing bearing
			CX2	CXWM	CXWL				CX2	CXWM	CXWL
1	-X138	Adjustable stroke	●	●	●	3	-X168	Helical insert thread	●	●	●
2	-X146	Hollow piston rod	●	●	●	4	-X169	2 built-in magnets	●	●	●

1 Adjustable Stroke

Symbol
-X138

C Auto switch X Type Bore size Stroke -X138

Adjustable stroke ↓

Adjustment of +2 to -25 mm (max. -12.5 mm on one side) is possible exceeding the stroke adjustment range (±2 mm stroke) of standard type.

Specifications

Bearing	Slide bearing		Ball bushing bearing
	Series	CX2□	CXWM
Type	Non-lube/Air-hydro		Non-lube
Bore size	ø10, ø15, ø25 *		ø10, ø16, ø20, ø25, ø32
Cushion	-		Built-in shock absorber
Stroke adjustable range	+2 mm to -25 mm (One side: Maximum -12.5 mm)		

* Air-hydro type is not available for size ø10.

Select adjustable stroke type auto switch (-X138)

⚠ Caution

When 50 strokes are adjusted to 40 strokes or less with the adjustable stroke type (-X138), auto switches may not be able to be mounted properly since they interfere with each other if the 2 in-line entry auto switches are used. When strokes are adjusted to 40 strokes or less, select the perpendicular entry type or additionally select auto switches with 2 built-in magnets (-X169).

Dimensions

CX2N10 to 25/CXWM_L10 to 25

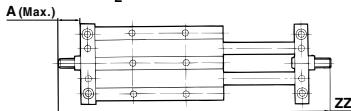

CXWM_L20/32

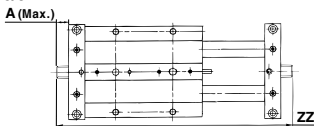

Model	A (Max.)	ZZ							
		25 st	50 st	75 st	100 st	125 st	150 st	175 st	200 st
CX2N10	19	150	200	250	300	-	-	-	-
CX2□15	18	152	202	252	302	352	402	452	502
CX2□25	19	179	229	279	329	379	429	479	529
CXWM10	20	-	204	254	304	-	-	-	-
CXWM16	18	-	212	262	312	362	412	462	512
CXWM20	8	-	200	250	300	350	400	450	500
CXWM25	19	-	229	279	329	379	429	479	529
CXWM32	10	-	283	333	383	433	483	533	
CXWL10	20	188	238	288	338	-	-	-	-
CXWL16	18	208	258	308	358	408	458	508	558
CXWL20	8	194	244	294	344	394	444	494	544
CXWL25	19	225	275	325	375	425	475	525	575
CXWL32	10	-	274	324	374	424	474	524	574

* The -X138 is intended for use with the model with an adjusting bolt on both sides.
* Excludes the CXW with end lock (as the lock mechanism adjustment range is 2 mm)

2 Hollow Piston Rod Specifications

Symbol
-X146

C Auto switch X Type Bore size Stroke -X146

Hollow piston rod ↓

Piping on the plate side can be used pressurization and evacuation. For cylinder drive, piping shall be on the housing port. (The slide unit operation with piping on the plate side impossible.)

Specifications

Bearing	Slide bearing		Ball bushing bearing
	Series	CX2□	CXWM
Type	Non-lube/Air-hydro		Non-lube
Bore size (mm)	ø10, ø15, ø25 *		ø10, ø16, ø20, ø25, ø32
Cushion	With shock absorber (option)		Built-in shock absorber

* Air-hydro type is not available for size ø10.

Construction

ø10

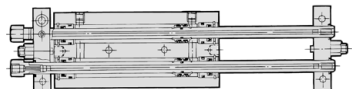

ø15, ø16, ø25

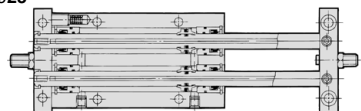

ø20, ø32

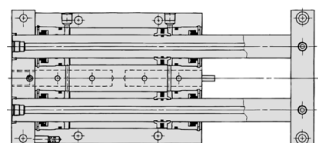

CX2/CXW Series

Made to Order: Individual Specifications 2

Please contact SMC for detailed dimensions, specifications and lead times.



3 Helical Insert Thread Specifications

Symbol
-X168

In this type, helical insert thread is used for mounting the housing.

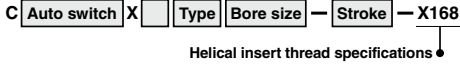

Dimensions

CX2N10

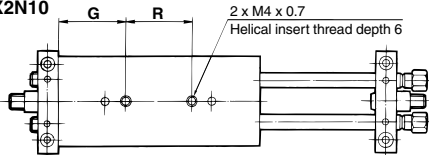

CX2N10

Model	G	R
CX2N10-25	19.5	28
CX2N10-50	30	32
CX2N10-75	35	47
CX2N10-100	35	72

CXWM10, CXWL10

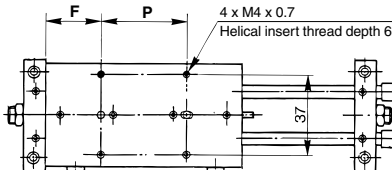

CXWM10

Model	F	P
CXWM10-25	21	25
CXWM10-50	26	40
CXWM10-75	26	65
CXWM10-100	26	90

CXWL10

Model	F	P
CXWL10-25	35.5	30
CXWL10-50	38	50
CXWL10-75	40.5	70
CXWL10-100	43	90

CXWM20, CXWL20, CXWM32, CXWL32

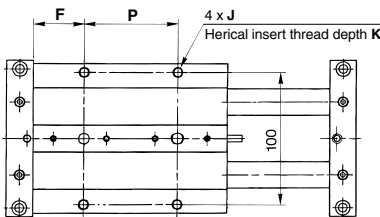

Stroke	CXWM20		CXWL20		CXWM32		CXWL32	
	F	P	F	P	F	P	F	P
25 mm	27	25	35.5	22	37	22	55	
50 mm	34.5	35	48	60		45	80	
75 mm	34.5	60	56.5	60		70	105	
100 mm	39.5	75	54			95	130	
125 mm	44.5		66.5		38	125	155	41
150 mm	57		79	90		145	180	
175 mm	69.5	90	91.5			175	205	
200 mm	82		104			195	230	

Specifications

Bearing	Slide bearing		Ball bushing bearing
Series	CX2□	CXWM	CXWL
Type	Non-lube/Air-hydro	Non-lube	Non-lube
Bore size	ø10, ø15, ø25*	ø10, ø16, ø20, ø25, ø32	
Cushion	With shock absorber (option)		Built-in shock absorber

* Air-hydro type is not available for size ø10.

Helical Insert Thread

Series	Bore size	J	K
CX2□	ø15	4 x M5 x 0.8	Helical insert thread depth 7
	ø25	4 x M6 x 1.0	Helical insert thread depth 9
CXWM	ø16	4 x M5 x 0.8	Helical insert thread depth 7
	ø25	4 x M6 x 1.0	Helical insert thread depth 9
CXWL	ø16	4 x M5 x 0.8	Helical insert thread depth 7
	ø25	4 x M6 x 1.0	Helical insert thread depth 9

CX2□15, CXWM16, CXWL16, CX2□25, CXWM25, CXWL25

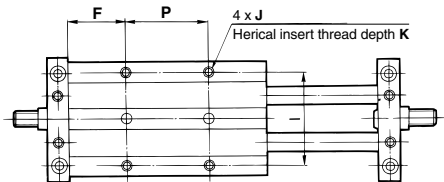

CX2□15

Stroke	F	P	I
25 mm	24.5	20	41
50 mm	24.5	45	
75 mm	27	65	
100 mm	27	90	
125 mm	39.5	90	
150 mm	52	90	
175 mm	64.5	90	
200 mm	77	90	

CXWM16

Stroke	F	P	I
25 mm	25	25	53
50 mm	35	30	
75 mm	32.5	60	
100 mm	37.5	75	
125 mm	42.5	90	
150 mm	55	90	
175 mm	67.5	90	
200 mm	80	90	

CXWL16

Stroke	F	P	I
25 mm	34.5	52	53
50 mm	47	52	
75 mm	53	65	
100 mm	53	90	
125 mm	65.5	90	
150 mm	78	90	
175 mm	90.5	90	
200 mm	103	90	

CX2□25, CXWM25

Stroke	F	P	I
25 mm	28.5	25	67
50 mm	31	45	
75 mm	33.5	65	
100 mm	33.5	90	
125 mm	46	90	
150 mm	58.5	90	
175 mm	71	90	
200 mm	83.5	90	

CXWL25

Stroke	F	P	I
25 mm	31.5	65	67
50 mm	31.5	90	
75 mm	56.5	65	
100 mm	56.5	90	
125 mm	69	90	
150 mm	81.5	90	
175 mm	94	90	
200 mm	106.5	90	

CX2

CXW

CXT

CXSJ

CXS

D-□

-X□

CX2/CXW Series

Made to Order: Individual Specifications 3

Please contact SMC for detailed dimensions, specifications and lead times.



4 With 2 Built-in Magnets

Symbol

-X169

C Auto switch X Type Bore size — Stroke — X169
 With 2 built-in magnets ↓

Two magnets for auto switch detection are built in.

* 25 strokes: 2 magnets as standard. This specification is applicable for 50 strokes or more.

Specifications

Bearing	Slide bearing		Ball bushing bearing
Series	CX2□	CXWM	CXWL
Type	Non-lube/Air-hydro	Non-lube	Non-lube
Bore size	ø10, ø15, ø25 *		
Cushion	With shock absorber (option)	Built-in shock absorber	