

Manifold Regulator Modular Type **ARM2500/3000 Series**

- A modular type that can be freely mounted on a manifold station.
- Optimal for central pressure control.
- Easily set up using the new knob. Also has a One-touch lock system.



ARM3000



ARM2500

How to Order

ARM 2500 — 05 A — 02 G1

Regulator for manifold

Body size

2500
3000

Number of stations

02	2 stations
⋮	⋮
10	10 stations

Accessory (Pressure gauge)

Nil	None (With plug)
G1	Back side thread: G33-10-□01
G2	Vertical side thread: GA33-10-□01

* Pressure gauges are shipped together (but not assembled).

Port size (OUT side)

Symbol	Port size	Applicable model
02	1/4	ARM2500
03	3/8	ARM3000

Thread type

Nil	Rc
N	NPT
F	G

Piping

Symbol	Type	IN
A	Common IN	From end plate
B	Individual IN	From OUT port or G port

Standard Specifications

Proof pressure	1.5 MPa
Maximum operating pressure	1.0 MPa
Regulating pressure range	0.05 to 0.85 MPa
Ambient and fluid temperature	-5 to 60°C (No freezing)
Fluid	Air
Construction	Relieving type

Symbol

Common IN

Individual IN

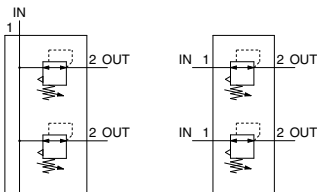

JIS Symbol

With backflow function

Port Size/Weight

Model	Piping	Port size			Pressure gauge port size	Weight (kg)	
		IN side		OUT side		Regulator	End plate
		Body	End plate				
ARM2500	Common IN	—	3/8	1/4	1/8	0.26	0.06
	Individual IN	1/4	—	1/4	1/8		
ARM3000	Common IN	—	1/2	3/8	1/8	0.47	0.11
	Individual IN	3/8	—	3/8	1/8		

Weight by the Number of Stations

(kg)

Model	Stations	2	3	4	5	6	7	8	9	10
ARM2500		0.68	0.96	1.23	1.51	1.78	2.06	2.33	2.61	2.89
ARM3000		1.25	1.75	2.25	2.75	3.26	3.76	4.26	4.76	5.26

Option: Pressure Gauge (Max. pressure indication: 1.0 MPa)

G33-10-□01

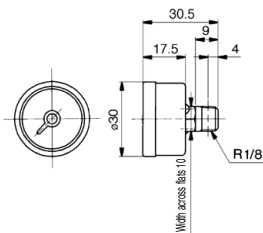

GA33-10-□01

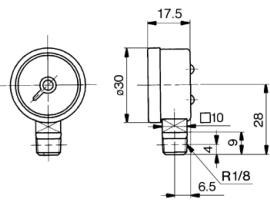

Note 1) □ in the gauge part no. (e.g. G33-10-□01) indicates the type of threads used for connection. For Rc, leave the symbol blank, and for NPT, enter "N".

Please consult with SMC for the supply of a pressure gauge with NPT port threads.

Note 2) Use caution not to tighten excessively when mounting a pressure gauge, otherwise it may result in a breakdown. For sealing, use a sealant tape.

Option/Mounting Bolt Assembly

Model	Part no.	Dimensions	Qty.	Note
ARM2500	136313	Hexagon socket head cap screw (M5 x 70)	4	With flat washer
ARM3000	136413	Hexagon socket head cap screw (M6 x 85)	4	With flat washer

Option/Bracket Assembly

Individual IN type can be used as a single unit regulator.

Example of mounting

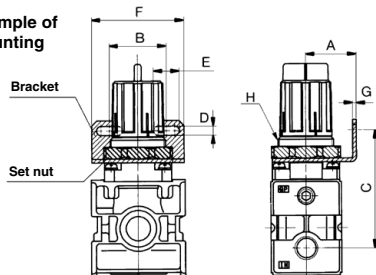

Model	Part no.	Composition of assembly	A	B	C	D	E	F	G	H
ARM2500	136314	Set nut (1349172)	30	34	70	5.4	15.4	55	2.3	M33 x 1.5
		Bracket (B220)								
ARM3000	136414	Set nut (131532)	41	40	75.5	6.5	8	53	2.3	M42 x 1.5
		Bracket (B320)								

Note) Tighten the set nut securely and fix it.

Recommended torque for set nut

ARM2500: 17.5 ± 3.5 N·m

ARM3000: 22.5 ± 4.5 N·m

Flow Rate Characteristics (Representative Value)

Initial pressure: = 0.7 MPa

ARM2500

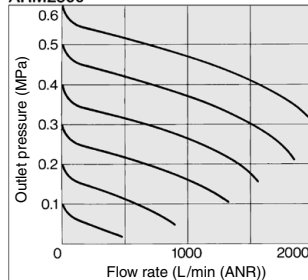

ARM3000

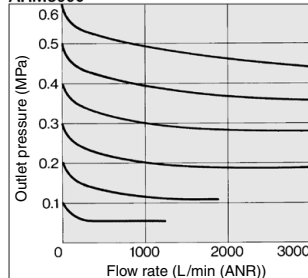

Pressure Characteristics (Representative Value)

Initial setting
P1 = 0.7 MPa P2 = 0.2 MPa
Q = 20 L/min (ANR)

ARM2500

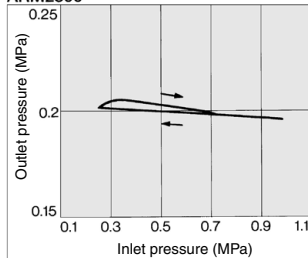

ARM3000

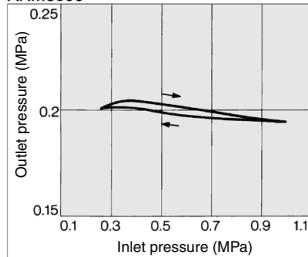

ARJ

AR425
to 935

ARX

AMR

ARM

ARP

IR□-A

IR

IRV

VEV

SRH

SRP

SRF

ITV

IC

ITVH

ITVX

PVQ

VY1

VBA

VBAT

AP100

ARM2500/3000 Series

Construction

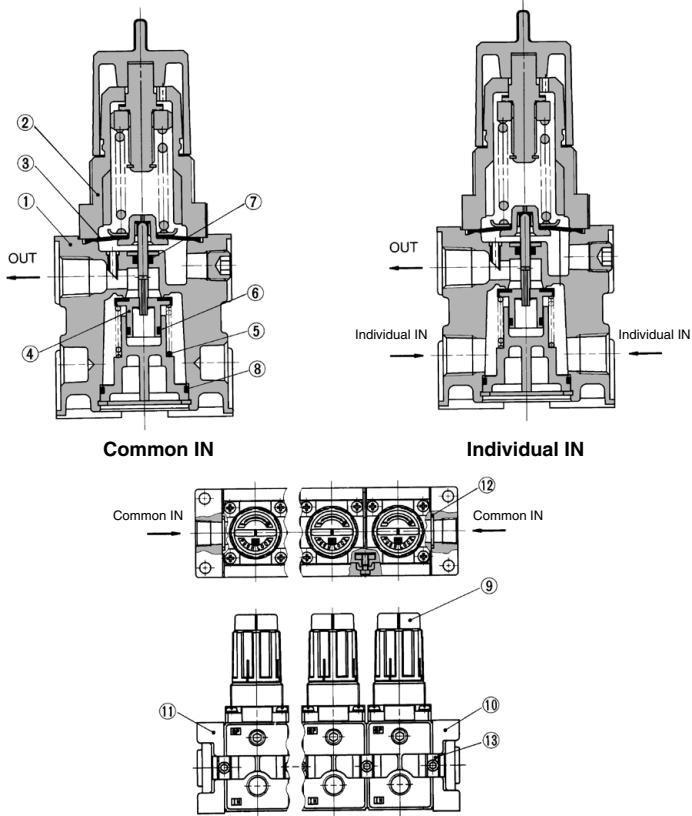

Component Parts

No.	Description	Material	Note
1	Body	Aluminum die-casted	Chromate treated/Platinum silver painted
2	Bonnet	Polyacetal	

Replacement Parts

No.	Description	Material	Part no.	
			ARM2500	ARM3000
3	Diaphragm assembly	Weather resistant NBR	1349161A	131515A
4	Valve assembly	Brass, HNBR	13639A	13649A
5	Valve spring	Stainless steel	136310	136410
6	Valve O-ring	NBR	KA00892 11.5 x 8.5 x 1.5	KA00904 14.5 x 10.5 x 2
7	O-ring	NBR	KA00078 JIS B 2401 P3	KA00083 JIS B 2401 P5
8	O-ring	NBR	KA00299 28 x 25 x 1.5	KA00961 35 x 31 x 2

Component Parts

Description	No.	Assembly		Part no.			
		Component	Qty.	ARM2500		ARM3000	
				Common IN	Individual IN	Common IN	Individual IN
Regulator	9	Regulator	1	ARM2500-A-02	ARM2500-B-02	ARM3000-A-03	ARM3000-B-03
	10	End plate R	1				
	11	End plate L	1				
End plate assembly	12	O-ring	1				
	13	Bracket Bracket A Bracket B Hex. socket head cap screw	2	13636A	13636B (Except O-ring)	13646A	13646B (Except O-ring)
			1 set				
Bracket assembly	12	O-ring	1				
	13	Bracket Bracket A Bracket B Hex. socket head cap screw	2		136312		136412
			1 set				
	2						

How to order

(1) When adding n stations to ARM ²⁵⁰⁰/₃₀₀₀ - □ □ □ □^A

- Regulator n pcs.
- Bracket assembly n pcs.

(2) When regulators, end plate assembly and bracket assembly are assembled to make the manifold of n stations.

- Regulator n pcs.
- Bracket assembly n pcs.
- End plate assembly 1 pc.

Dimensions

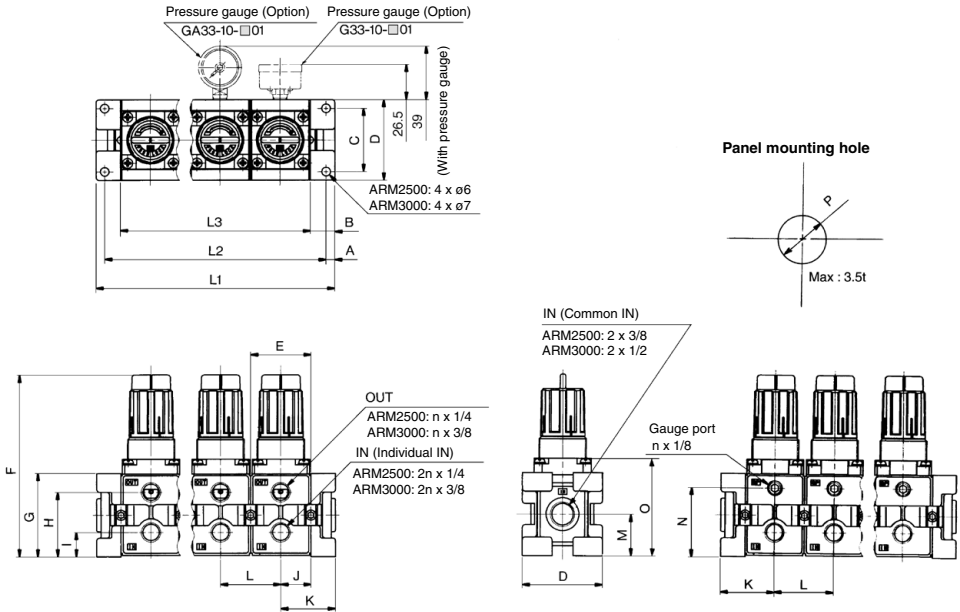

Dimensions

* For products with pressure gauge, pressure gauges are shipped together with product.

Model	Symbol	A	B	C	D	E	F	G	H	I	J	K	L	M	N	O	P
		ARM2500	6	17	44	56	42	126.5	58	45	17	21	38	42	29	48	68
ARM3000	7	21	54	68	55	153.5	70	53	23.5	27.5	48.5	55	35	59	85.5	42.5	

Dimensions by the Number of Stations

Model	Symbol	Manifold stations									
		2	3	4	5	6	7	8	9	10	
ARM2500	L1	118	160	202	244	286	328	370	412	454	
	L2	106	148	190	232	274	316	358	400	442	
	L3	84	126	168	210	252	294	336	378	420	
ARM3000	L1	152	207	262	317	372	427	482	537	592	
	L2	138	193	248	303	358	413	468	523	578	
	L3	110	165	220	275	330	385	440	495	550	

ARJ
AR425 to 935
ARX
AMR
ARM
ARP
IR□-A
IR
IRV
VE X
SRH
SRP
SRF
ITV
IC
ITVH
ITVX
PVQ
VY1
VBA
VBAT
AP100



ARM2500/3000 Series

Specific Product Precautions

Be sure to read this before handling the products.

Refer to back page 50 for Safety Instructions and pages 387 to 391 for Precautions on every series.

Mounting/Adjustment

Caution

1. Release the lock to adjust the pressure. After the adjustment, engage the lock. Failure to observe this procedure could damage the knob or cause the secondary pressure to fluctuate.
 - 1) On the ARM2500 type, pull the adjustment knob to release the lock and push the adjustment knob to engage the lock. If it does not lock easily, turn the knob slightly clockwise or counterclockwise before pushing it.
 - 2) On the ARM3000 type, pull the adjustment knob to release the lock. (An orange colored line is provided at the bottom of the adjustment knob for visual checking.)
Push the adjustment knob to engage the lock. If it does not lock easily, turn the knob slightly clockwise or counterclockwise; then, push it until the orange colored line is no longer visible.
2. Make sure to check the inlet pressure before setting the pressure. The outlet pressure must be set to 85% or less of the inlet pressure.
Failure to observe this procedure could cause the outlet pressure to fluctuate.
3. In the case of the common IN type, supply pressure from the two IN ports from both ends. Failure to observe this procedure could lead to an excessive pressure drop.

Selection

Warning

1. For ARM2500/3000, releasing the inlet pressure does not mean that all residual pressure is released (the outlet pressure cannot be released). When releasing residual pressure, use a manifold regulator with a backflow function (X216).

Caution

1. When operating at an inlet pressure lower than the inlet pressure used in the flow rate characteristics graph, the pressure drop on the outlet side may be greater. Therefore, be sure to conduct testing using the actual equipment.
For pressure control equipment selection, refer to page 123 in the "Product Selection Guide."

Maintenance

Warning

1. Make sure to perform a periodic inspection of the pressure gauge when the manifold regulator with a backflow function is installed between a solenoid valve and an actuator. Sudden pressure changes could happen and the durability of the product could be reduced. Using an electronic type pressure gauge is recommended, depending on the situation.