

MITSUBISHI IGBT MODULES
CM600HX-24A

HIGH POWER SWITCHING USE

CM600HX-24A



- Ic 600A
- VCES 1200V
- Single
- Flatbase Type / Insulated Package / Copper (non-plating) base plate
- RoHS Directive compliant

APPLICATION

General purpose Inverters, Servo Amplifiers, Power supply, etc.

OUTLINE DRAWING & CIRCUIT DIAGRAM

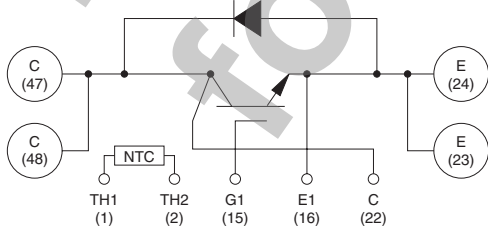
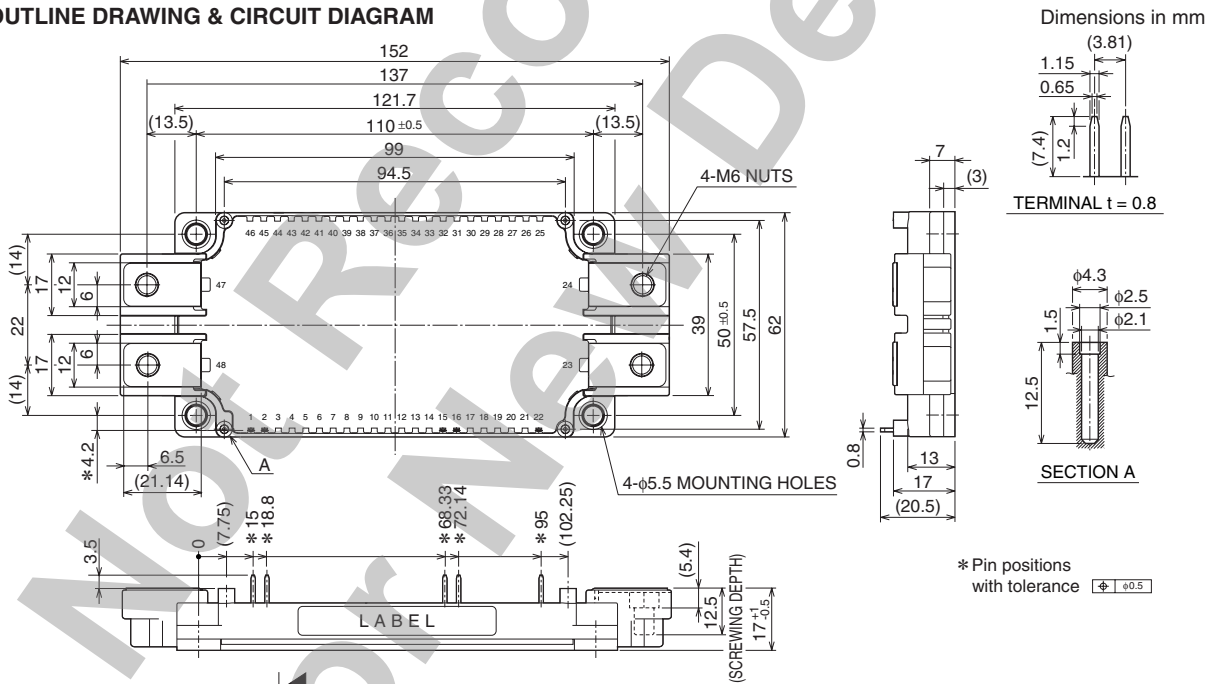

* Use both terminals (C/E) to the external connection.

CIRCUIT DIAGRAM

Tolerance otherwise specified

| Division of Dimension | Tolerance |
|-----------------------|-----------|
| 0.5 to 3 | ±0.2 |
| over 3 to 6 | ±0.3 |
| over 6 to 30 | ±0.5 |
| over 30 to 120 | ±0.8 |
| over 120 to 400 | ±1.2 |

ABSOLUTE MAXIMUM RATINGS (T_j = 25°C, unless otherwise specified)

INVERTER PART

| Symbol | Parameter | Conditions | Rating | Unit |
|---------------------------|---------------------------------------|--|------------|------------------|
| V _{CES} | Collector-emitter voltage | G-E Short | 1200 | V |
| V _{GES} | Gate-emitter voltage | C-E Short | ±20 | |
| I _C | Collector current | DC, T _c = 90°C (Note. 1) | 600 | A |
| I _{CRM} | | Pulse (Note. 4) | 1200 | |
| P _C | Maximum collector dissipation | T _c = 25°C (Note. 1, 5) | 3785 | W |
| I _E (Note.3) | Emitter current | T _c = 25°C (Note. 1) | 600 | A |
| I _{ERM} (Note.3) | (Free wheeling diode forward current) | Pulse (Note. 4) | 1200 | |
| T _j | Junction temperature | | -40 ~ +150 | °C |
| T _{stg} | Storage temperature | | -40 ~ +125 | |
| V _{iso} | Isolation voltage | Terminals to base plate, f = 60Hz, AC 1 minute | 2500 | V _{rms} |
| — | Base plate flatness | On the centerline X, Y (Note. 8) | ±0 ~ +100 | μm |
| — | Torque strength | Main terminals M6 screw | 3.5 ~ 4.5 | N·m |
| — | Torque strength | Mounting M5 screw | 2.5 ~ 3.5 | |
| — | Weight | (Typical) | 330 | g |

Note. 8: The base plate flatness measurement points are in the following figure.

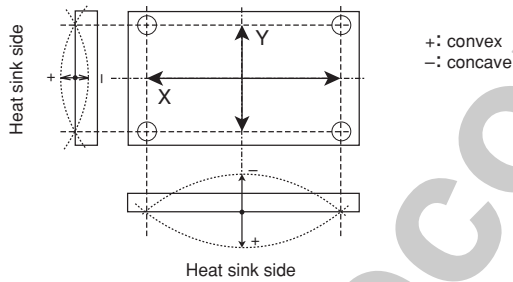

ELECTRICAL CHARACTERISTICS (T_j = 25°C, unless otherwise specified)

INVERTER PART

| Symbol | Parameter | Conditions | Limits | | | Unit | |
|--------------|--|----------------------------------|------------------------|-------|-------|------|---|
| | | | Min. | Typ. | Max. | | |
| ICES | Collector cutoff current | VCE = VCES, VGE = 0V | — | — | 1 | mA | |
| VGE(th) | Gate-emitter threshold voltage | IC = 60mA, VCE = 10V | 6 | 7 | 8 | V | |
| IGES | Gate leakage current | ±VGE = VGES, VCE = 0V | — | — | 0.5 | μA | |
| VCE(sat) | Collector-emitter saturation voltage | IC = 600A, VGE = 15V (Note. 6) | T _j = 25°C | 2.0 | 2.6 | V | |
| | | | T _j = 125°C | 2.2 | — | | |
| | | IC = 600A, VGE = 15V | Chip | 1.9 | — | | |
| Cies | Input capacitance | VCE = 10V VGE = 0V (Note. 6) | — | — | 100 | nF | |
| Coes | Output capacitance | | — | — | 9 | | |
| Cres | Reverse transfer capacitance | | — | — | 2 | | |
| QG | Total gate charge | VCC = 600V, IC = 600A, VGE = 15V | — | 3000 | — | nC | |
| td(on) | Turn-on delay time | VCC = 600V, IC = 600A | — | — | 660 | ns | |
| tr | Turn-on rise time | VGE = ±15V, RG = 1.0Ω | — | — | 190 | | |
| td(off) | Turn-off delay time | Inductive load | — | — | 700 | | |
| tf | Turn-off fall time | | — | — | 600 | | |
| trr (Note.3) | Reverse recovery time | | — | — | 250 | | |
| Qrr (Note.3) | Reverse recovery charge | (IE = 600A) | — | 19 | — | μC | |
| VEC(Note.3) | Emitter-collector voltage | IE = 600A, VGE = 0V (Note. 6) | T _j = 25°C | 2.6 | 3.4 | V | |
| | | | T _j = 125°C | 2.16 | — | | |
| | | | IE = 600A, VGE = 0V | Chip | 2.5 | — | |
| Rlead | Module lead resistance | Main terminals-chip | — | 0.6 | — | mΩ | |
| Rth(j-c)Q | Thermal resistance | per IGBT | — | — | 0.033 | K/W | |
| Rth(j-c)R | (Junction to case) (Note. 1) | per free wheeling diode | — | — | 0.048 | | |
| Rth(c-f) | Contact thermal resistance (Case to heat sink) (Note. 1) | Thermal grease applied (Note. 2) | — | 0.015 | — | | |
| RGint | Internal gate resistance | | Tc = 25°C | 0.7 | 1 | 1.3 | Ω |
| | | | Tc = 125°C | 1.4 | 2 | 2.6 | |
| RG | External gate resistance | | 1 | — | 10 | | |

NTC THERMISTOR PART

| Symbol | Parameter | Conditions | Limits | | | Unit |
|----------|-------------------------|-----------------------------------|--------|------|------|------|
| | | | Min. | Typ. | Max. | |
| R | Zero power resistance | Tc = 25°C | 4.85 | 5.00 | 5.15 | kΩ |
| ΔR/R | Deviation of resistance | Tc = 100°C, R100 = 493Ω | -7.3 | — | +7.8 | % |
| B(25/50) | B constant | Approximate by equation (Note. 7) | — | 3375 | — | K |
| P25 | Power dissipation | Tc = 25°C | — | — | 10 | mW |

Note. 1: Case temperature (T_c), heat sink temperature (T_h) measured point is just under the chips. (Refer to the figure of the chip location.)

2: Typical value is measured by using thermally conductive grease of λ = 0.9W/(m·K).

3: IE, IERM, VEC, trr and Qrr represent ratings and characteristics of the anti-parallel, emitter-collector free wheeling diode (FWDi).

4: Pulse width and repetition rate should be such that the device junction temperature (T_j) dose not exceed T_{jmax} rating.

5: Junction temperature (T_j) should not increase beyond 150°C.

6: Pulse width and repetition rate should be such as to cause negligible temperature rise.

(Refer to the figure of the test circuit for VCE(sat) and VEC)

$$7: B(25/50) = \ln \left(\frac{R_{25}}{R_{50}} \right) \left(\frac{1}{T_{25}} - \frac{1}{T_{50}} \right)$$

R₂₅: resistance at absolute temperature T₂₅ [K]; T₂₅ = 25 [°C]+273.15 = 298.15 [K]

R₅₀: resistance at absolute temperature T₅₀ [K]; T₅₀ = 50 [°C]+273.15 = 323.15 [K]

Chip Location (Top view)

Dimensions in mm (tolerance: ±1mm)

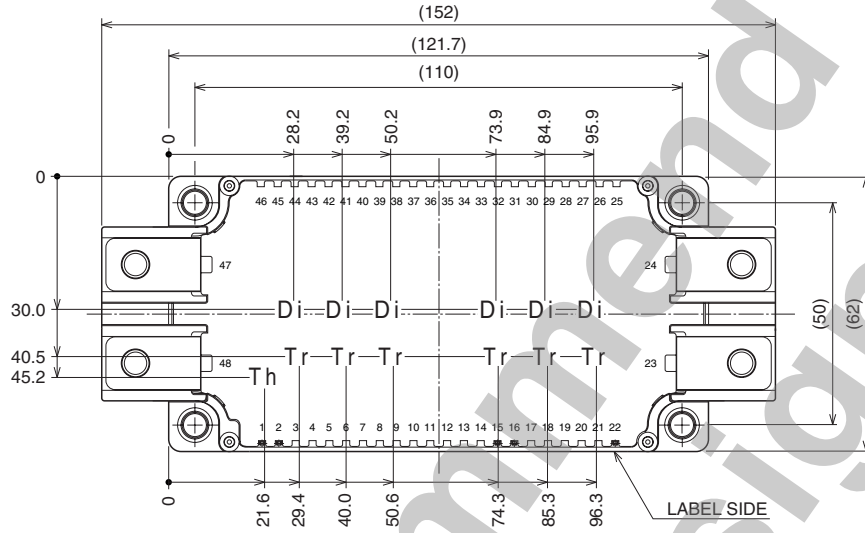

Each mark points the center position of each chip. Tr: IGBT, Di: FWDi, Th: NTC thermistor

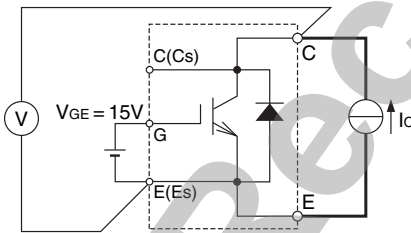

VCE(sat) test circuit

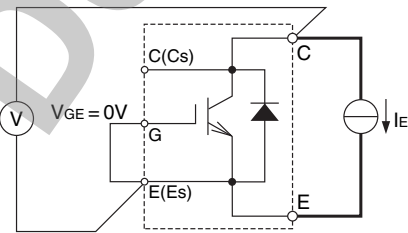

Vec test circuit

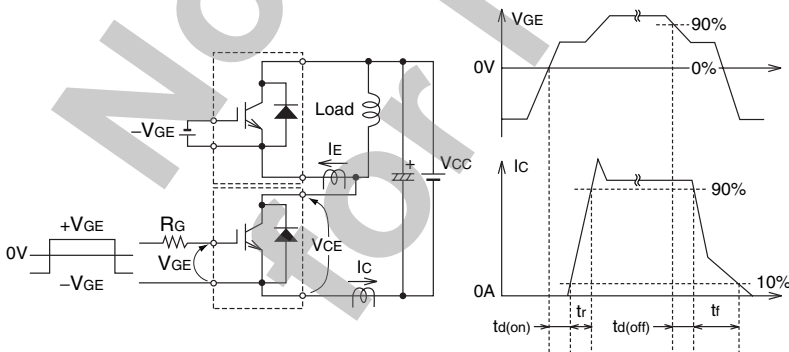

Switching time test circuit and waveforms

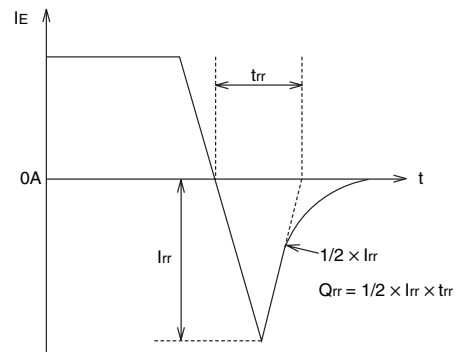

trr, Qrr test waveform

PERFORMANCE CURVES

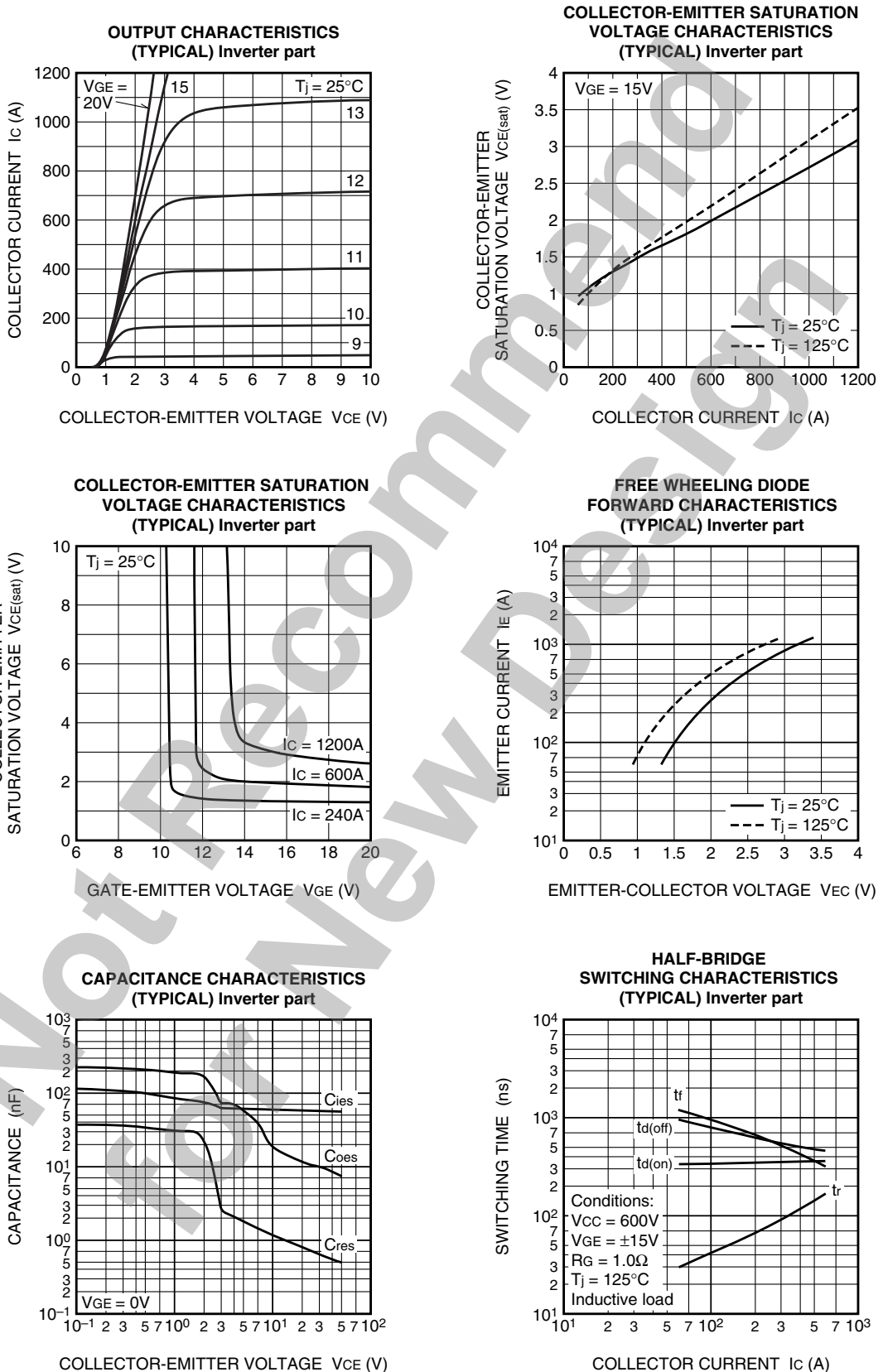

HALF-BRIDGE SWITCHING CHARACTERISTICS (TYPICAL) Inverter part

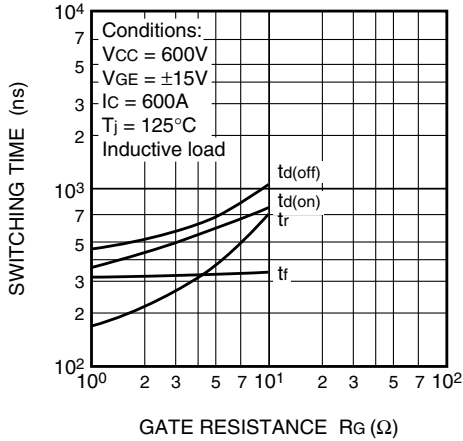

HALF-BRIDGE SWITCHING CHARACTERISTICS (TYPICAL) Inverter part

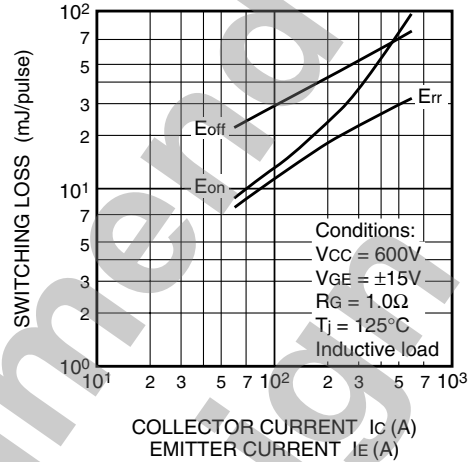

HALF-BRIDGE SWITCHING CHARACTERISTICS (TYPICAL) Inverter part

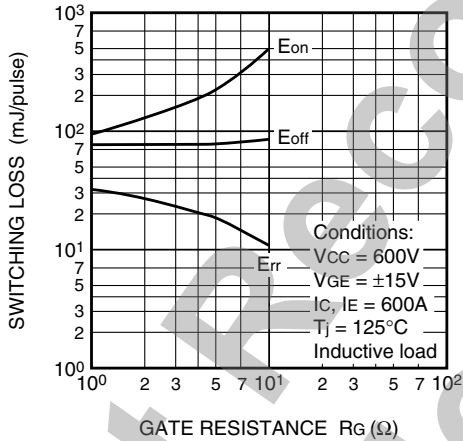

REVERSE RECOVERY CHARACTERISTICS OF FREE WHEELING DIODE (TYPICAL) Inverter part

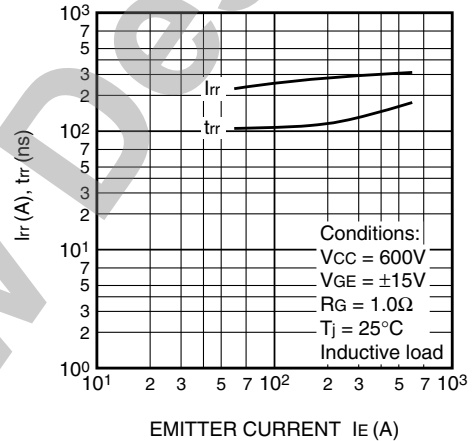

GATE CHARGE CHARACTERISTICS (TYPICAL) Inverter part

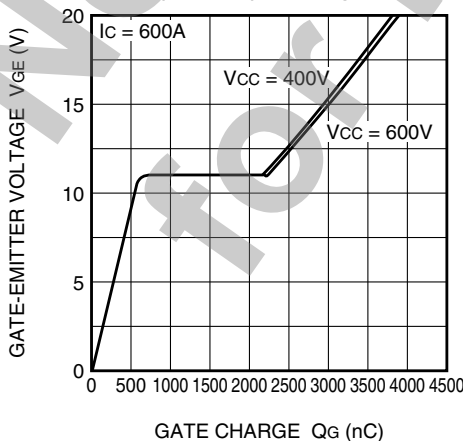

TRANSIENT THERMAL IMPEDANCE CHARACTERISTICS

