

Symmetra™ PX

250/500 kW 400/480 V

Technical Specifications

7/2023



Legal Information

The Schneider Electric brand and any trademarks of Schneider Electric SE and its subsidiaries referred to in this guide are the property of Schneider Electric SE or its subsidiaries. All other brands may be trademarks of their respective owners.

This guide and its content are protected under applicable copyright laws and furnished for informational use only. No part of this guide may be reproduced or transmitted in any form or by any means (electronic, mechanical, photocopying, recording, or otherwise), for any purpose, without the prior written permission of Schneider Electric.

Schneider Electric does not grant any right or license for commercial use of the guide or its content, except for a non-exclusive and personal license to consult it on an "as is" basis. Schneider Electric products and equipment should be installed, operated, serviced, and maintained only by qualified personnel.

As standards, specifications, and designs change from time to time, information contained in this guide may be subject to change without notice.

To the extent permitted by applicable law, no responsibility or liability is assumed by Schneider Electric and its subsidiaries for any errors or omissions in the informational content of this material or consequences arising out of or resulting from the use of the information contained herein.

Table of Contents

Important Safety Instructions — SAVE THESE	
INSTRUCTIONS	5
Safety Precautions	6
Technical Data	8
Model List	8
Efficiency (TÜV Certified)	9
Efficiency Curves	9
Derating due to Load Power Factor	10
Batteries	10
Battery Runtimes	12
Battery Gassing Rates Per Shelf/String (Cubic Feet per Hour).....	19
Battery Discharge Current	20
End of Discharge Voltage at 100% Load	20
Communication and Management	20
Relay Inputs/Outputs.....	20
Emergency Power Off (EPO).....	22
Compliance.....	23
Facility Planning	24
Input Specifications	24
Bypass Specifications	24
Output Specifications.....	25
Battery Specifications	25
Overview of Systems with Maintenance Bypass.....	26
Single Configurations	26
Overview of Systems without Maintenance Bypass	27
Single Configurations	27
Parallel Configurations	28
UL-Specific Specifications.....	29
Recommended Fuses, Breakers, and Cables for UL.....	29
Recommended Bolt and Lug Sizes for UL.....	33
IEC-Specific Specifications.....	34
Surge Protection Device (SPD).....	34
Upstream and Downstream Protection for IEC	35
Recommended Fuses, Breakers, and Cables for IEC	36
Recommended Bolt and Lug Sizes for IEC.....	38
Required Breaker Settings for Input Overload and Short-Circuit	
Protection for Breakers with Electronic Trip Units	38
Torque Specifications.....	38
Physical.....	39
Weights and Dimensions	39
Shipping Weights and Dimensions	39
Clearance	40
Environmental	42
Heat Dissipation	42
Drawings	43
Symmetra PX 500 kW 400 V Single Utility/Mains with Maintenance	
Bypass and Line-Up-And-Match Batteries – Bottom Feed.....	44

Symmetra PX 500 kW 400 V Single Utility/Mains with Maintenance Bypass and Line-Up-And-Match Batteries – Top Feed	45
Symmetra PX 500 kW 400 V Single Utility/Mains with Maintenance Bypass and Remote Batteries — Top Feed	46
Symmetra PX 500 kW 400 V Single Utility/Mains with Maintenance Bypass and Remote Batteries – Bottom Feed	47
Symmetra PX 500 kW 400 V Dual Mains with Maintenance Bypass and Line-Up-And-Match Batteries – Top Feed	48
Symmetra PX 500 kW 400 V Dual Utility/Mains with Maintenance Bypass and Remote Batteries – Bottom Feed	49
Symmetra PX 500 kW 400 V Dual Utility/Mains with Maintenance Bypass and Line-Up-And-Match Batteries – Bottom Feed	50
Symmetra PX 500 kW 400 V Dual Utility/Mains with Maintenance Bypass and Remote Batteries – Top Feed	51
Symmetra PX 500 kW 480 V Single Mains with Maintenance Bypass (3 Wire Output) and Line-Up-And-Match Batteries – Top Feed	52
Symmetra PX 500 kW 480 V Dual Mains with Maintenance Bypass (3 Wire Output) and Line-Up-And-Match Batteries – Top Feed	53
Symmetra PX 500 kW 480 V Single Mains with Maintenance Bypass (3 Wire Output) and Line-Up-And-Match Batteries – Bottom Feed	54
Symmetra PX 500 kW 480 V Dual Mains with Maintenance Bypass (3 Wire Output) and Line-Up-And-Match Batteries – Bottom Feed	55
Symmetra PX 500 kW 480 V Single Mains with Maintenance Bypass (4 Wire Output) and Line-Up-And-Match Batteries – Top Feed	56
Symmetra PX 500 kW 480 V Dual Mains with Maintenance Bypass (4 Wire Output) and Line-Up-And-Match Batteries – Top Feed	57
Symmetra PX 500 kW 480 V Single Mains with Maintenance Bypass (4 Wire Output) and Line-Up-And-Match Batteries – Bottom Feed	58
Symmetra PX 500 kW 480 V Dual Mains with Maintenance Bypass (4 Wire Output) and Line-Up-And-Match Batteries – Bottom Feed	59
Options	60
Hardware Options	60
Configuration Options	61
Limited Factory Warranty	62

Important Safety Instructions — SAVE THESE INSTRUCTIONS

Read these instructions carefully and look at the equipment to become familiar with it before trying to install, operate, service or maintain it. The following safety messages may appear throughout this manual or on the equipment to warn of potential hazards or to call attention to information that clarifies or simplifies a procedure.



The addition of this symbol to a “Danger” or “Warning” safety message indicates that an electrical hazard exists which will result in personal injury if the instructions are not followed.



This is the safety alert symbol. It is used to alert you to potential personal injury hazards. Obey all safety messages with this symbol to avoid possible injury or death.

DANGER

DANGER indicates a hazardous situation which, if not avoided, **will result in death or serious injury.**

Failure to follow these instructions will result in death or serious injury.

WARNING

WARNING indicates a hazardous situation which, if not avoided, **could result in death or serious injury.**

Failure to follow these instructions can result in death, serious injury, or equipment damage.

CAUTION

CAUTION indicates a hazardous situation which, if not avoided, **could result in minor or moderate injury.**

Failure to follow these instructions can result in injury or equipment damage.

NOTICE

NOTICE is used to address practices not related to physical injury. The safety alert symbol shall not be used with this type of safety message.

Failure to follow these instructions can result in equipment damage.

Please Note

Electrical equipment should only be installed, operated, serviced, and maintained by qualified personnel. No responsibility is assumed by Schneider Electric for any consequences arising out of the use of this material.

A qualified person is one who has skills and knowledge related to the construction, installation, and operation of electrical equipment and has received safety training to recognize and avoid the hazards involved.

Per IEC 62040-1: "Uninterruptible power systems (UPS) -- Part 1: Safety Requirements," this equipment, including battery access, must be inspected, installed and maintained by a skilled person.

The skilled person is a person with relevant education and experience to enable him or her to perceive risks and to avoid hazards which the equipment can create (reference IEC 62040, section 3.102).

Safety Precautions

⚠ DANGER

HAZARD OF ELECTRIC SHOCK, EXPLOSION, OR ARC FLASH

- The product must be installed according to the specifications and requirements as defined by Schneider Electric. It concerns in particular the external and internal protections (upstream circuit breakers, battery circuit breakers, cabling, etc.) and environmental requirements. No responsibility is assumed by Schneider Electric if these requirements are not respected.
- After the UPS system has been electrically wired, do not start up the system. Start-up must only be performed by Schneider Electric.

Failure to follow these instructions will result in death or serious injury.

⚠ DANGER

HAZARD OF ELECTRIC SHOCK, EXPLOSION, OR ARC FLASH

The UPS System must be installed according to local and national regulations. Install the UPS according to:

- IEC 60364 (including 60364-4-41- protection against electric shock, 60364-4-42 - protection against thermal effect, and 60364-4-43 - protection against overcurrent), **or**
- NEC NFPA 70

depending on which one of the standards apply in your local area.

Failure to follow these instructions will result in death or serious injury.

⚠ DANGER

HAZARD OF ELECTRIC SHOCK, EXPLOSION, OR ARC FLASH

- Install the UPS system in a temperature controlled area free of conductive contaminants and humidity.
- Install the UPS system on a non-flammable, level, and solid surface (e.g. concrete) that can support the weight of the system.

Failure to follow these instructions will result in death or serious injury.

⚠ DANGER

HAZARD OF ELECTRIC SHOCK, EXPLOSION, OR ARC FLASH

The UPS is not designed for and must therefore not be installed in the following unusual operating environments:

- Damaging fumes
- Explosive mixtures of dust or gases, corrosive gases, or conductive or radiant heat from other sources
- Moisture, abrasive dust, steam or in an excessively damp environment
- Fungus, insects, vermin
- Salt-laden air or contaminated cooling refrigerant
- Pollution degree higher than 2 according to IEC 60664-1
- Exposure to abnormal vibrations, shocks, and tilting
- Exposure to direct sunlight, heat sources, or strong electromagnetic fields

Failure to follow these instructions will result in death or serious injury.

NOTICE

RISK OF OVERHEATING

Respect the clearance requirements around the UPS system and do not cover the product's ventilation openings when the UPS system is in operation.

Failure to follow these instructions can result in equipment damage.

NOTICE

RISK OF EQUIPMENT DAMAGE

Do not connect the UPS output to regenerative load systems including photovoltaic systems and speed drives.

Failure to follow these instructions can result in equipment damage.

Technical Data

Model List

Systems with Maintenance Bypass and Distribution

Part Number	Description
SY100K250DR-PD	100 kW scalable to 250 kW with right mounted maintenance bypass and distribution
SY125K250DL-PD	125 kW scalable to 250 kW with left mounted maintenance bypass and distribution
SY125K250DR-PD	125 kW scalable to 250 kW with right mounted maintenance bypass and distribution
SY125K250DR-PDNB	125 kW scalable to 250 kW with right mounted maintenance bypass and distribution, No Batteries
SY125K500DR-PD	125 kW scalable to 500 kW with right mounted maintenance bypass and distribution
SY125K500DR-PDNB	125 kW scalable to 500 kW with Maintenance Bypass and Distribution, No Batteries
SY150K250DR-PD	150 kW scalable to 250 kW with right mounted maintenance bypass and distribution
SY200K250DR-PD	200 kW scalable to 250 kW with right mounted maintenance bypass and distribution
SY250K500DL-PD	250 kW scalable to 500 kW with left mounted maintenance bypass and distribution
SY250K500DR-PD	250 kW scalable to 500 kW with right mounted maintenance bypass and distribution
SY300K500DR-PD	300 kW scalable to 500 kW with right mounted maintenance bypass and distribution
SY400K500DR-PD	400 kW scalable to 500 kW with right mounted maintenance bypass and distribution
SY500K500DL-PD	500 kW scalable to 500 kW with left mounted maintenance bypass and distribution
SY500K500DR-PD	500 kW scalable to 500 kW with right mounted maintenance bypass and distribution

Systems without Maintenance Bypass and Distribution

Part Number	Description
SY100K250D	100 kW scalable to 250 kW without maintenance bypass and distribution - parallel capable
SY125K250D	125 kW scalable to 250 kW without maintenance bypass and distribution - parallel capable
SY125K250D-NB	125 kW scalable to 250 kW without maintenance bypass, distribution and batteries - parallel capable
SY125K500D	125 kW scalable to 500 kW without maintenance bypass and distribution - parallel capable
SY125K500D-NB	125 kW scalable to 500 kW without maintenance bypass, distribution and batteries - parallel capable
SY150K250D	150 kW scalable to 250 kW without maintenance bypass and distribution - parallel capable
SY200K250D	200 kW scalable to 250 kW without maintenance bypass and distribution - parallel capable
SY250K500D	250 kW scalable to 500 kW without maintenance bypass and distribution - parallel capable
SY300K500D	300 kW scalable to 500 kW without maintenance bypass and distribution - parallel capable
SY400K500D	400 kW scalable to 500 kW without maintenance bypass and distribution - parallel capable
SY500K500D	500 kW scalable to 500 kW without maintenance bypass and distribution - parallel capable

Efficiency (TÜV Certified)

480 V Systems

System	25% load	50% load	75% load	100% load
250 kW	95.2	96.2	96.3	96.3
500 kW	95.5	96.3	96.4	96.3

400/415 V Systems

System	25% load	50% load	75% load	100% load
250 kW	95.5	96.1	96.0	95.7
500 kW	95.5	96.1	96.0	95.6

Efficiency Curves

500 kW 400 V

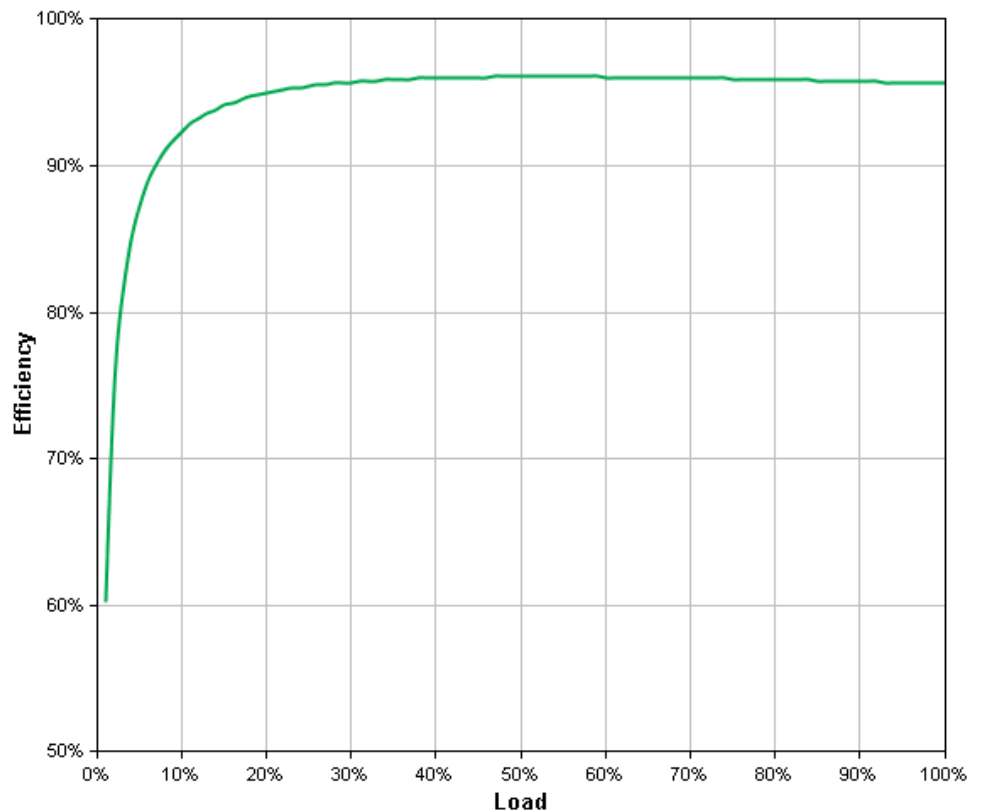

Curve fit to measured efficiency data. All measurements taken in normal operating mode, at typical environmental conditions, with 400 V 50 Hz input and 400 V 50 Hz balanced resistive load (PF = 1.0) output.

500 kW 480 V

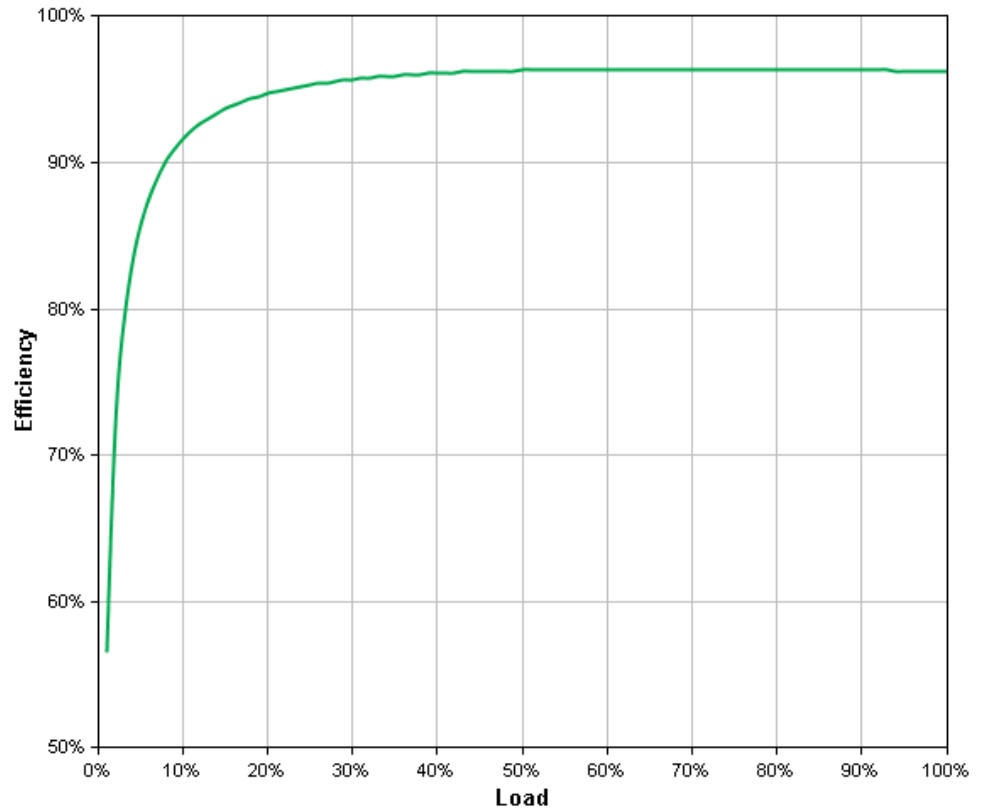

Curve fit to measured efficiency data. All measurements taken in normal operating mode, at typical environmental conditions, with 480 V 60 Hz input and 480 V 60 Hz balanced resistive load (PF = 1.0) output.

Derating due to Load Power Factor

The Symmetra PX 250/500kW load power factor is from 0.5 leading to 0.5 lagging without any derating.

Batteries

Efficiency DC to AC (TÜV Certified)

480 V Systems

System	25% load	50% load	75% load	100% load
250 kW	95.5	96.3	96.6	96.5
500 kW	95.5	96.3	96.4	96.3

400/415 V Systems

System	25% load	50% load	75% load	100% load
250 kW	96.0	96.5	96.6	96.3
500 kW	95.8	96.4	96.5	96.3

Electrolyte Values

	Single Cartridge	Single Shelf (6 cartridges)	16 Shelves (96 cartridges)
Electrolyte Volume	2.19 L (0.58 gal)	13.14 L (3.48 gal)	210.24 L (55.68 gal)
Electrolyte Weight	2.88 kg (6.35 lbs)	17.28 kg (38.1 lbs)	276.48 kg (609.6 lbs)
Sulfuric Acid Weight	1.14 kg (2.50 lbs)	6.84 kg (15.0 lbs)	109.44 kg (240.0 lbs)
Note 1: Symmetra PX 250 kW has 6 cartridges per shelf; maximum 16 shelves (8 shelves for each 125 kW) Note 2: Symmetra PX 500 kW has 6 cartridges per shelf; maximum 32 shelves (8 shelves for each 125 kW)			

Material Safety Data Sheets

The Symmetra PX 250/500 kW battery cabinets use batteries manufactured by four different vendors; EnerSys, Panasonic, Portalac, and CSB. The vendor of the specific battery can be identified on either the label on the packaging or on the label on the front of the battery.

ID	Battery vendor
C69	CSB
E85	EnerSys
P270	Panasonic
G85	Portalac

The material safety data sheets are placed in the knowledge base on www.apc.com.

Battery Runtimes

Symmetra PX 100 kW Scalable to 250 kW 400/480 V Battery Run-Times (Minutes)

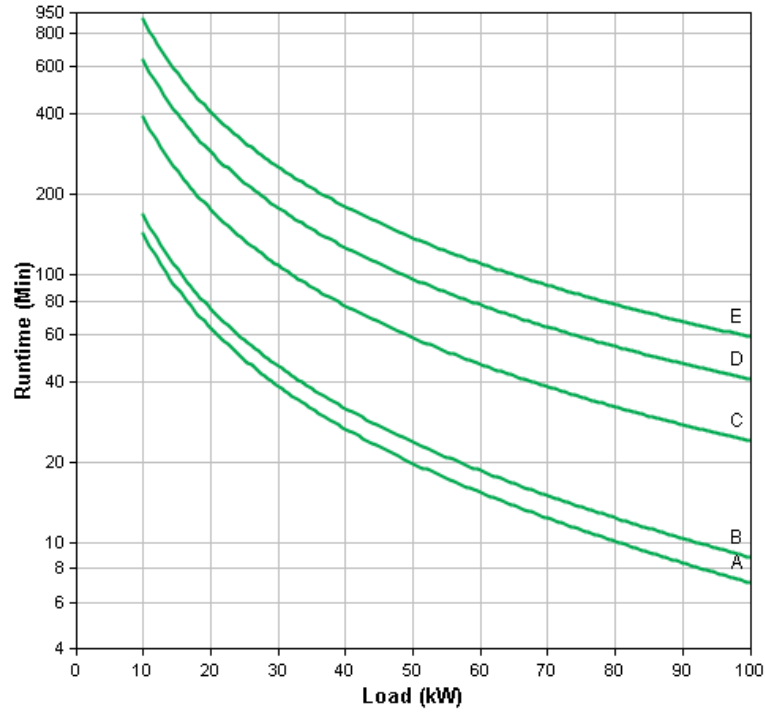

	Part numbers	Load (kW)				
		20	40	60	80	100
A	SY100K250D SY100K250DL-PD SY100K250DR-PD	63	27	15	10	7
B	+ (1)SYBT9-B6 or SYBT9-B6LL	75	32	19	12	9
C	+ (1)SYBFXR8-8	176	76	47	32	24
D	+ (2)SYBFXR8-8	288	126	77	54	41
E	+ (3)SYBFXR8-8	408	180	110	77	59

Symmetra PX 125 kW Scalable to 250/500 kW 400/480 V Battery Run-Times (Minutes)

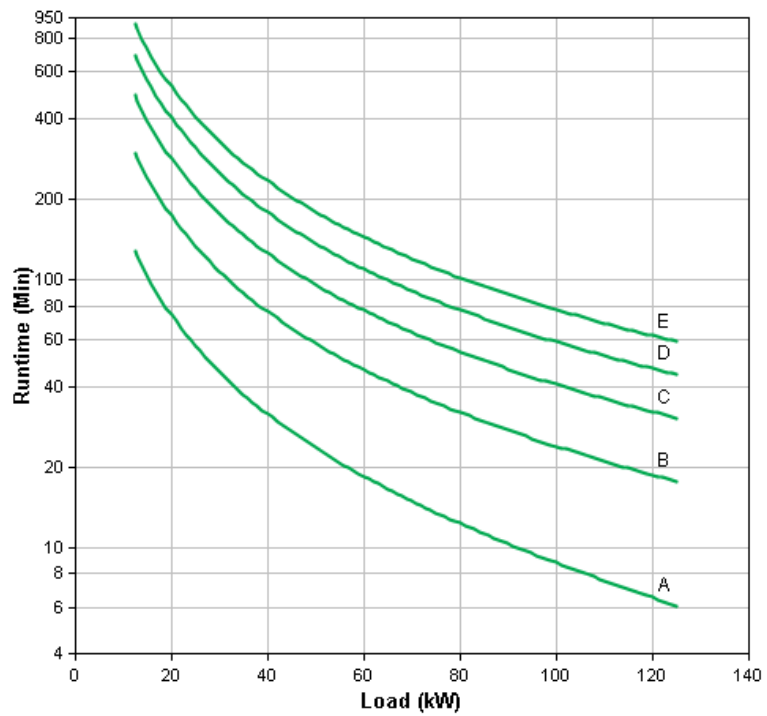

	Part numbers	Load (kW)					
		20	40	60	80	100	125
A	SY125K250D SY125K250DR-PD SY125K250DL-PD	74	32	19	12	9	6
B	+ (1)SYBFXR8-8	174	76	46	32	24	18
C	+ (2)SYBFXR8-8	285	126	77	54	41	31
D	+ (3)SYBFXR8-8	404	179	110	77	59	44
E	+ (4)SYBFXR8-8	529	235	144	102	77	59

Symmetra PX 150 kW Scalable to 250 kW 400/480 V Battery Run-Times (Minutes)

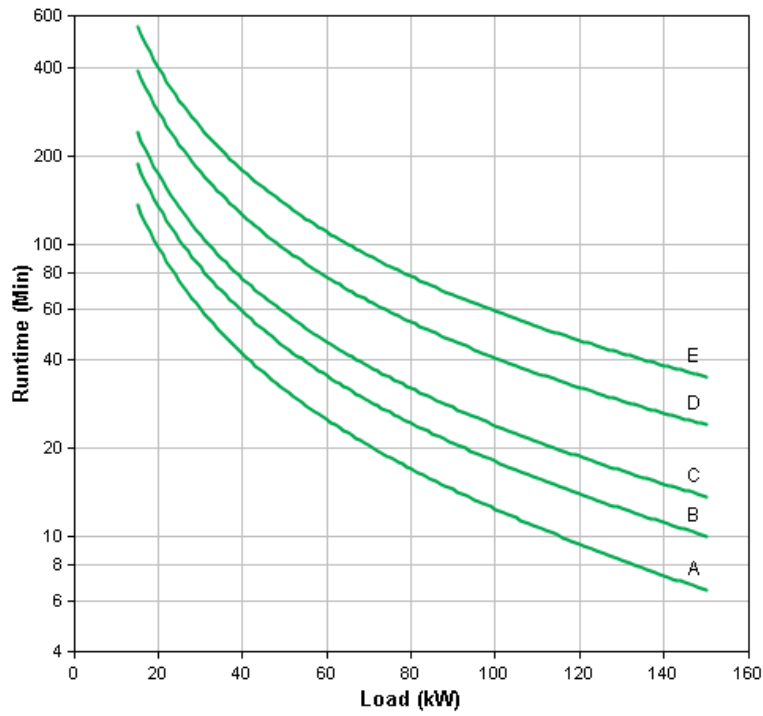

	Part numbers	Load (kW)						
		20	40	60	80	100	125	150
A	SY150K250D SY150K250DL-PD SY150K250DR-PD	97	42	25	17	12	9	7
B	+ (3)SYBT9-B6 or SYBT9-B6LL	134	59	35	24	18	13	10
C	+ (6)SYBT9-B6 or SYBT9-B6LL	173	76	46	32	24	18	14
D	+ (1)SYBFXR8-8	283	125	76	54	41	31	24
E	+ (2)SYBFXR8-8	401	178	109	77	59	44	35

Symmetra PX 200 kW Scalable to 250 kW 400/480 V Battery Run-Times (Minutes)

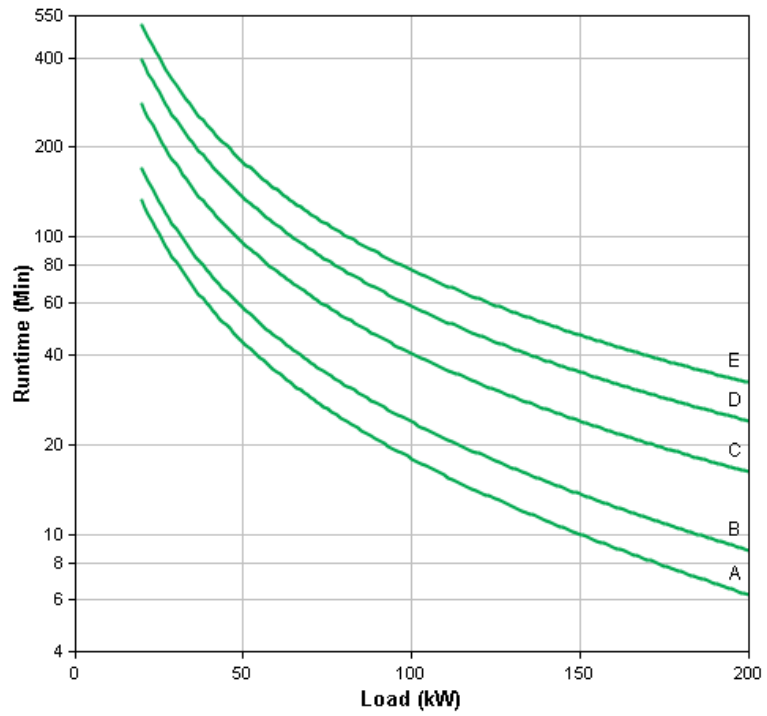

		Load (kW)								
	Part numbers	20	40	60	80	100	125	150	175	200
A	SY200K250S SY200K250DL-PD SY200K250DR-PD	131	58	35	24	18	13	10	8	6
B	+ (3)SYBT9-B6 or SYBT9-B6LL	170	75	46	32	24	18	14	11	9
C	+ (1)SYBFXR8-8	278	124	76	54	41	30	24	19	16
D	+ (2)SYBFXR8-8	394	177	109	77	59	44	35	29	24
E	+ (3)SYBFXR8-8	516	232	143	101	77	59	47	38	32

Symmetra PX 250 kW Scalable to 500 kW 400/480 V Battery Run-Times (Minutes)

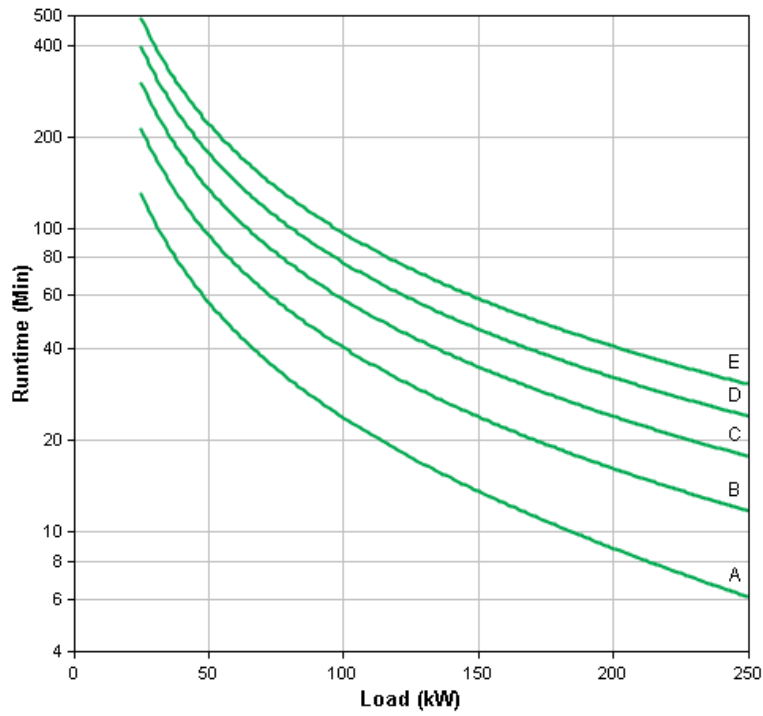

	Part numbers	Load (kW)									
		20	40	60	80	100	125	150	175	200	250
A	SY250K500D SY250K500DL-PD SY250K500DR-PD	167	74	46	32	24	18	14	11	9	6
B	+ (1)SYBFXR8-8	273	123	76	53	40	30	24	19	16	12
C	+ (2)SYBFXR8-8	387	175	108	76	58	44	35	29	24	18
D	+ (3)SYBFXR8-8	507	230	142	101	77	59	47	38	32	24
E	+ (4)SYBFXR8-8	632	287	178	126	96	73	59	48	41	31

Symmetra PX 300 kW Scalable to 500 kW 400/480 V Battery Run-Times (Minutes)

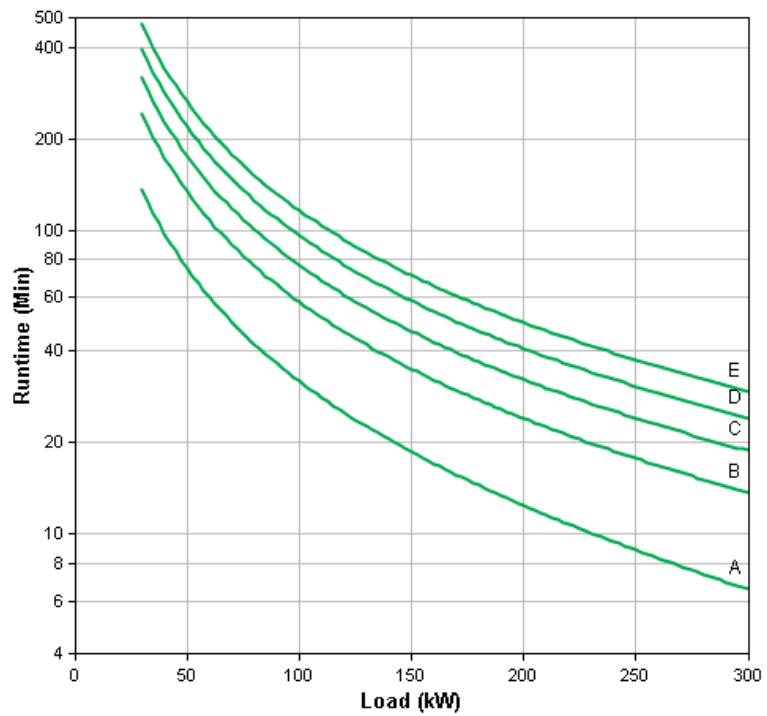

	Part numbers	Load (kW)									
		20	40	60	80	100	125	150	175	200	300
A	SY300K500D SY300K500DL-PD SY300K500DR-PD	215	97	60	42	32	24	19	15	12	7
B	+ (2)SYBFXR8-8	381	174	107	76	58	44	35	29	24	14
C	+ (3)SYBFXR8-8	622	284	177	126	96	73	59	48	41	24
D	+ (4)SYBFXR8-8	749	343	214	152	116	88	71	59	50	30
E	+ (5)SYBFXR8-8	880	403	251	179	137	104	83	69	59	35

Symmetra PX 400 kW Scalable to 500 kW 400/480 V Battery Run-Times (Minutes)

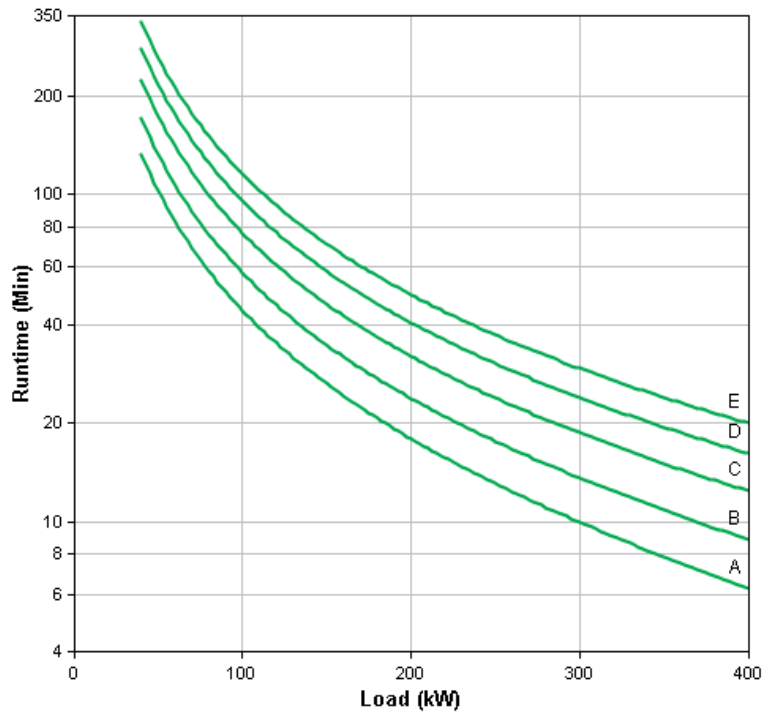

		Load (kW)										
	Part numbers	20	40	60	80	100	125	150	175	200	300	400
A	SY400K500D SY400K500DL-PD SY400K500DR-PD	287	132	82	58	44	33	26	22	18	10	6
B	+ (4)SYBT9-B6 or SYBT9-B6LL	369	171	106	75	58	44	35	28	24	14	9
C	+ (1)SYBFXR8-8	483	224	140	99	76	58	46	38	32	19	12
D	+ (2)SYBFXR8-8	602	280	175	124	95	72	58	48	41	24	16
E	+ (3)SYBFXR8-8	725	337	211	150	115	88	70	58	49	29	20

Symmetra PX 500 kW 400/480 V Battery Run-Times (Minutes)

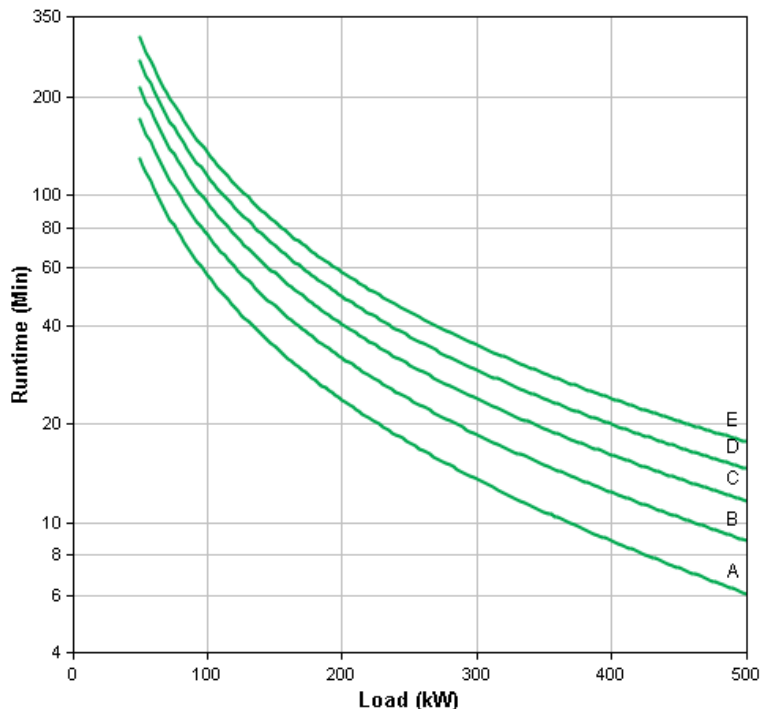

		Load (kW)											
Part numbers		20	40	60	80	100	125	150	175	200	300	400	500
A	SY500K500D SY500K500DR-PD SY500K500DL-PD	357	168	105	74	57	43	35	28	24	14	9	6
B	+(1)SYBFXR8-8	468	220	138	98	75	58	46	38	32	19	12	9
C	+(2)SYBFXR8-8	583	275	173	123	94	72	58	48	40	24	16	12
D	+(3)SYBFXR8-8	703	331	209	149	114	87	70	58	49	29	20	15
E	+(4)SYBFXR8-8	825	390	245	176	135	103	83	68	58	35	24	18

Battery Gassing Rates Per Shelf/String (Cubic Feet per Hour)

The battery gassing rates are calculated based on:

- Gassing rate at 2.4 V/cell (ft³/hr) assuming 98% recombination efficiency = 0.00021
- Six cells per cartridge
- Eight cartridges per battery unit
- Six battery units (one battery module) per shelf

Number of battery modules	1	2	3	4	5	6	7	8
	0.06048	0.12096	0.18144	0.24192	0.30240	0.36288	0.42336	0.48384

Battery Discharge Current

	250 kW	500 kW
I bat at bat nominal, 100% load	452	904
I bat at bat minimum, 100% load	565	1130
I bat at bat minimum, 150% load	678	1356

End of Discharge Voltage at 100% Load

NOTE: The voltage is 1.6 to 1.75 per cell depending on load.

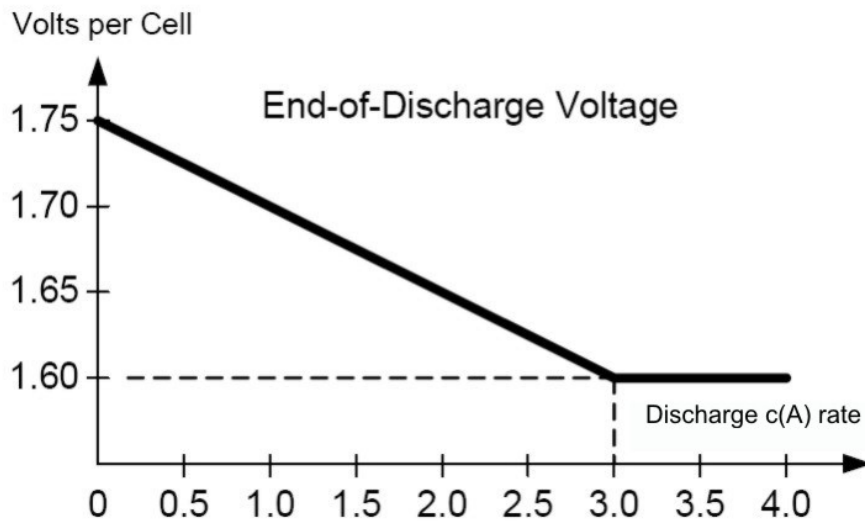

NOTE: C equals $I_{\text{discharge}}$ divided by the battery Ah capacity.

Communication and Management

Network Management Card

The system is equipped with one network management card for remote monitoring and control of an individual UPS. It is possible to add an additional network management card.

Relay Inputs/Outputs

The relay board informs the user of the operation mode, status, and alarm conditions and has eight input ports and 16 output terminals.

All wiring to the relay board should be considered as field wiring rated minimum 480 V, and must use copper conductors only.

NOTE: Communication cables to the relay board must be run through the openings in the middle of the I/O cabinet via the cable channel to the relay board.

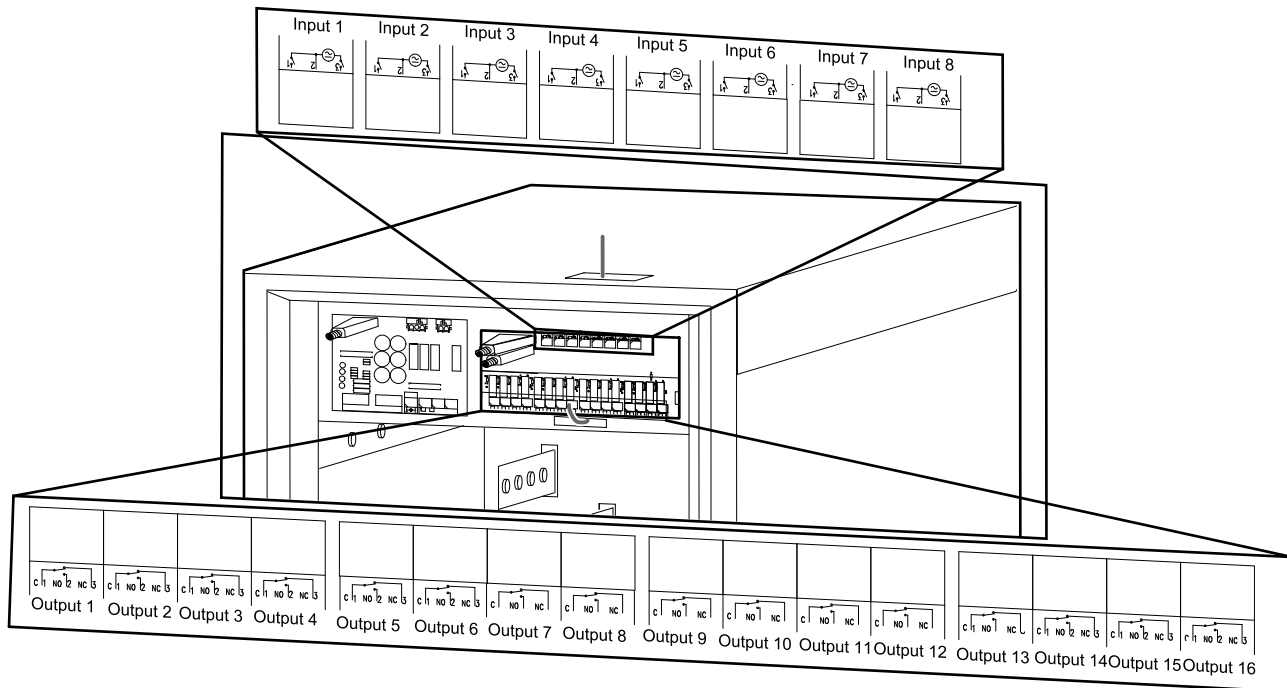

Inputs

All input voltages must have the same ground and 0 V reference.

- Minimum: 12 VAC/VDC
- Maximum: 28 VAC/40 VDC

Input 1	Reduction of charge power
Input 2	Boost charge inhibit
Input 3	Battery ground fault
Input 4	Enable external synchronization
Input 5	Internal use
Input 6	Internal use
Input 7	Door contact
Input 8	Activate mega tie mode

NOTE: When the UPS is installed in environments sensitive to interference, the EMC kit with three ferrite cores must be installed with three loops. Add a clip on ferrite for high frequency noises. Use kit 0J-9147.

Outputs

- Maximum. 8 A/250 VAC
- Maximum. 8 A/24 VDC

Output 1	Common alarm, configurable
Output 2	Normal operation, configurable
Output 3	Bypass operation, configurable
Output 4	Battery operation, configurable
Output 5	Battery voltage low, configurable
Output 6	Battery fault, configurable
Output 7	Maintenance bypass on, configurable
Output 8	Input outside tolerance, configurable
Output 9	Bypass outside tolerances, configurable
Output 10	Output outside tolerance, configurable
Output 11	Battery disconnected, configurable
Output 12	Overload on inverter/bypass, configurable
Output 13	Option 1, configured via display
Output 14	Option 2, configured via display
Output 15	Option 3, configured via display
Output 16	Option 4, configured via display

Emergency Power Off (EPO)

Single System (Normally Open)

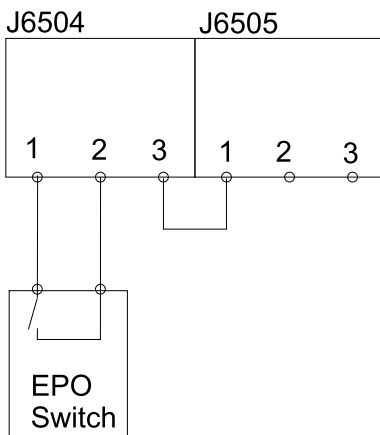

Parallel System (Normally Open)

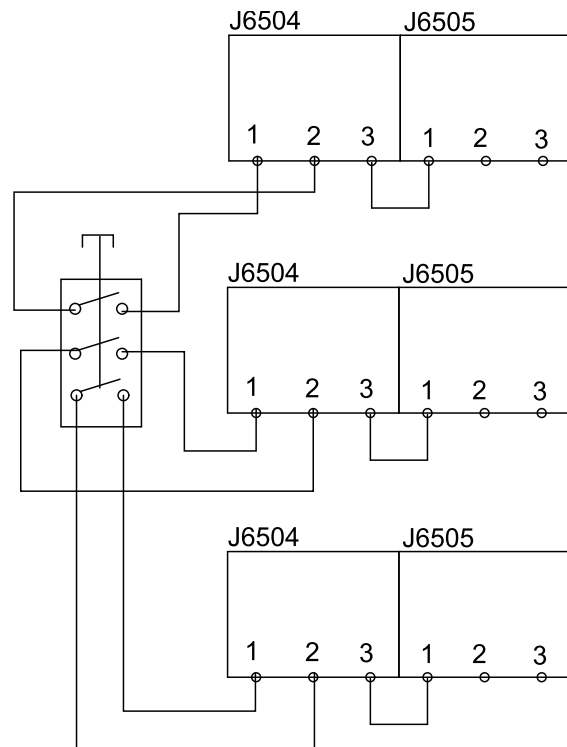

Compliance

Safety	IEC 62040-1: 2017, Edition 2.0, Uninterruptible Power Systems (UPS) - Part 1: Safety requirements UL 1778 5th edition
EMC/EMI/RFI	IEC 62040-2: 2016-11, 3rd edition Uninterruptible Power Systems (UPS) - Part 2: Electromagnetic compatibility (EMC) requirements C2 FCC Part 15 Subpart B, Class A
Transportation	ISTA 2B (2006)
Seismic	SE CoC in accordance with AC 156 protocol
Earthing system ¹	TN, TT, TNC, IT, TN-S, TNC-S
Overvoltage category	This UPS is OVCII compliant. If the UPS is installed in an environment with an OVC rating higher than II, an SPD (surge protection device) must be installed upstream of the UPS to reduce the overvoltage category to OVCII.
Protective class	I
Pollution degree	2

1. Refer to the Earthing Principles for more details.

Facility Planning

Input Specifications

Input voltage (V)	250 kW				500 kW			
	380 ²	400	415	480	380 ¹	400	415	480
Voltage range (v)	+/-15% at 100% load (340 - 460 V at 400 V, 408 - 552 V at 480 V) -50% for reduced load (200 V at 400 V, 240 V at 480 V)							
Input frequency (Hz)	40–70 with 10 Hz/sec slewrate							
THDI	< 5% at 100% load							
Nominal input current (A) ³	410	389	375	324	819	779	750	649
Maximum input current (A) ⁴	450	428	413	357	901	856	825	717
Input current limitation (A) ⁵	460	460	444	383	921	921	887	767
Maximum short circuit level I _{cw} (kA)	Rated short time withstand current I _{cw} : 65 kA. (50 kA with standard maintenance bypass) Rated peak withstand current I _{pk} : I _{cw} x 2.2							
Minimum short circuit current rating	Dependent on upstream protection. See section for Recommended Fuses, Breakers and Cables for details.							
Input power factor correction	0.995 at load = 100% 0.99 at load > 50% 0.97 at load > 25%							
Softstart (ramp-in) (seconds)	Configurable from 1 to 40 (default 10)							

Bypass Specifications

	250 kW				500 kW			
	380 V	400 V	415 V	480 V	380 V	400 V	415 V	480 V
Frequency (Hz)	50/60							
Nominal bypass current (A)	391	372	358	310	783	744	717	619
Maximum short circuit level I _{cw} (kA)	Rated short time withstand current I _{cw} : 65 kA. (50 kA with standard maintenance bypass) Rated peak withstand current I _{pk} : I _{cw} x 2.2							
Minimum short circuit current rating	Dependent on upstream protection. See section for Recommended Fuses, Breakers and Cables for details.							

2. 380 V has reduced input voltage window (-10% at 100% load).
3. Input current based on rated load and 100% charged batteries.
4. Input current based on 100% battery recharge, nominal voltage and rated load.
5. Current limitation through electronic current limiting is based on 100% battery recharge and -15% input voltage.

Output Specifications

	250 kW				500 kW			
	380 V	400 V	415 V	480 V	380 V	400 V	415 V	480 V
Overload capacity	150% for 60 seconds (normal operation) 125% for 10 minutes (normal operation) 150% for 60 seconds (battery operation) 125% for 10 minutes (battery operation) 125% continuous at 480 V and 110% continuous at 400 V (bypass operation) ⁶ 1000% for 100 milliseconds (bypass operation)							
Voltage tolerance	Symmetric load (0-100%): +/-1% static, +/-5% after 2 milliseconds and +/-1% after 50 milliseconds dynamic Asymmetric load (0-100%): +/-3% static							
Nominal output current (A)	391	372	358	310	783	744	717	619
Output frequency (sync to mains) (Hz)	50/60							
Slew rate (Hz/Sec)	0.25 - 6							
THDU	< 2% linear load < 3% non-linear load							
Output power factor	1							
Dynamic load response	+/- 5%							
Maximum short circuit level I _{cw} (kA)	Rated short time withstand current I _{cw} : 65 kA. (50 kA with standard maintenance bypass) Rated peak withstand current I _{pk} : I _{cw} x 2.2							
Minimum short circuit current rating	Dependent on upstream protection. See section for Recommended Fuses, Breakers and Cables for details.							

Battery Specifications

	250 kW	500 kW
Nominal battery voltage (VDC)	2 x +/- 288	
Battery current at 100% load and nominal battery voltage (A)	452	904
Battery current at 100% load and minimum battery voltage (A)	565	1130
End voltage (V)	1.6–1.75/cell (automatic, depending on load)	
Maximum short circuit withstand rating (kA)	40	
Minimum short circuit current rating	Dependent on upstream protection. See section for Recommended Fuses, Breakers and Cables for details.	

The UPS supports customer-specific battery solutions with 144 cells (+/- 6 cells) for runtime optimization. The display has settings for number of cells on DC voltage levels (V/cell).

NOTE: External Battery Breaker Enclosure (SYBBE) breaker setting is set to maximum. I_r = 1200A and I_m = 6000A.

Battery type	Sealed lead acid/wet cells
Nominal voltage (VDC)	+/- 276 to +/- 300
Float voltage (VDC)	+/- 308 to +/- 345
Boost charge voltage (VDC)	+/- 308 to +/- 345

6. This is a thermal performance rating. The continuous overload is not supported by the recommended input protection of the maintenance bypass.

Equalize charge voltage (VDC)	+/- 308 to +/- 345
End of discharge voltage at 100% load (VDC)	+/- 221 to +/- 263
Charging power	20% of nominal power at 0–90% load 10% of nominal power at 100% load
Typical recharge time	3.5 hours

NOTE: Battery specifications are based on VRLA batteries.

Overview of Systems with Maintenance Bypass

Single Configurations

NOTICE
HAZARD OF EQUIPMENT DAMAGE
The neutral connection to utility/mains must not be disconnected even in battery operation. Therefore 4–pole disconnectors/switches must not be used on the bypass.
Failure to follow these instructions can result in equipment damage.

Single Utility/Mains with Maintenance Bypass

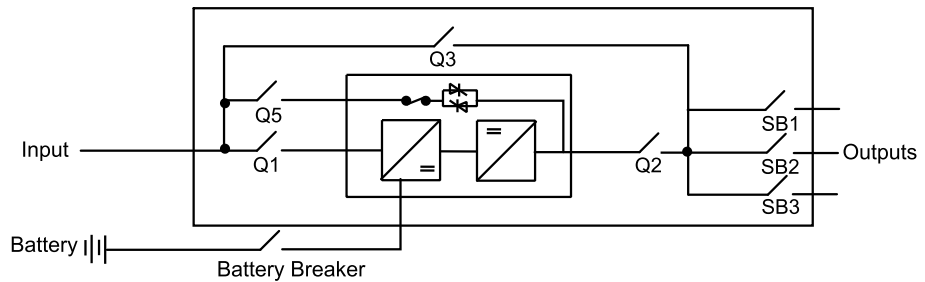

Dual Utility/Mains with Maintenance Bypass

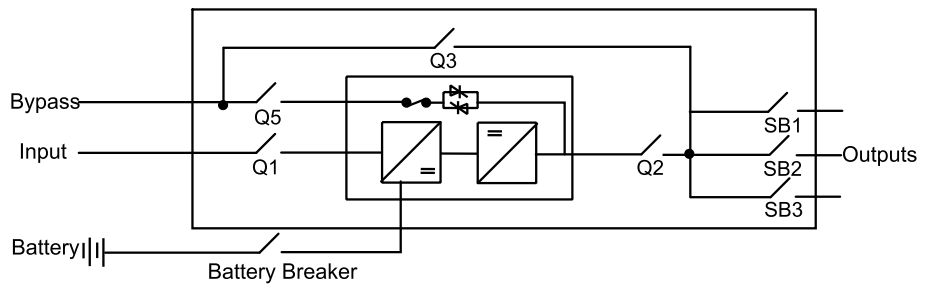

Overview of Systems without Maintenance Bypass

Single Configurations

NOTICE
HAZARD OF EQUIPMENT DAMAGE
The neutral connection to utility/mains must not be disconnected even in battery operation. Therefore 4–pole disconnectors/switches must not be used on the bypass.
Failure to follow these instructions can result in equipment damage.

Single Utility/Mains without Maintenance Bypass

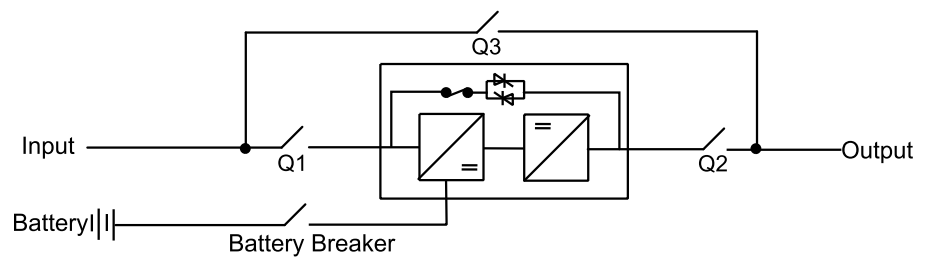

Dual Utility/Mains without Maintenance Bypass

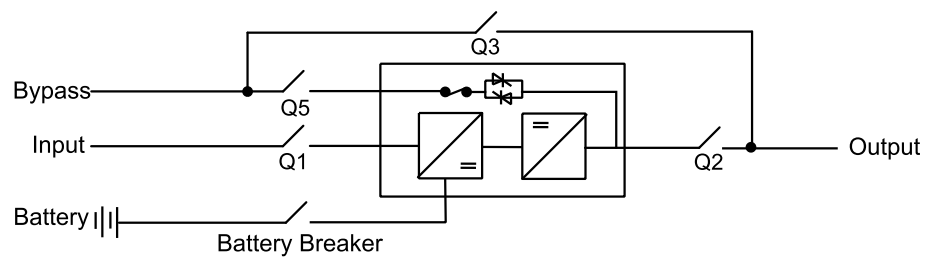

Parallel Configurations

Single Utility/Mains

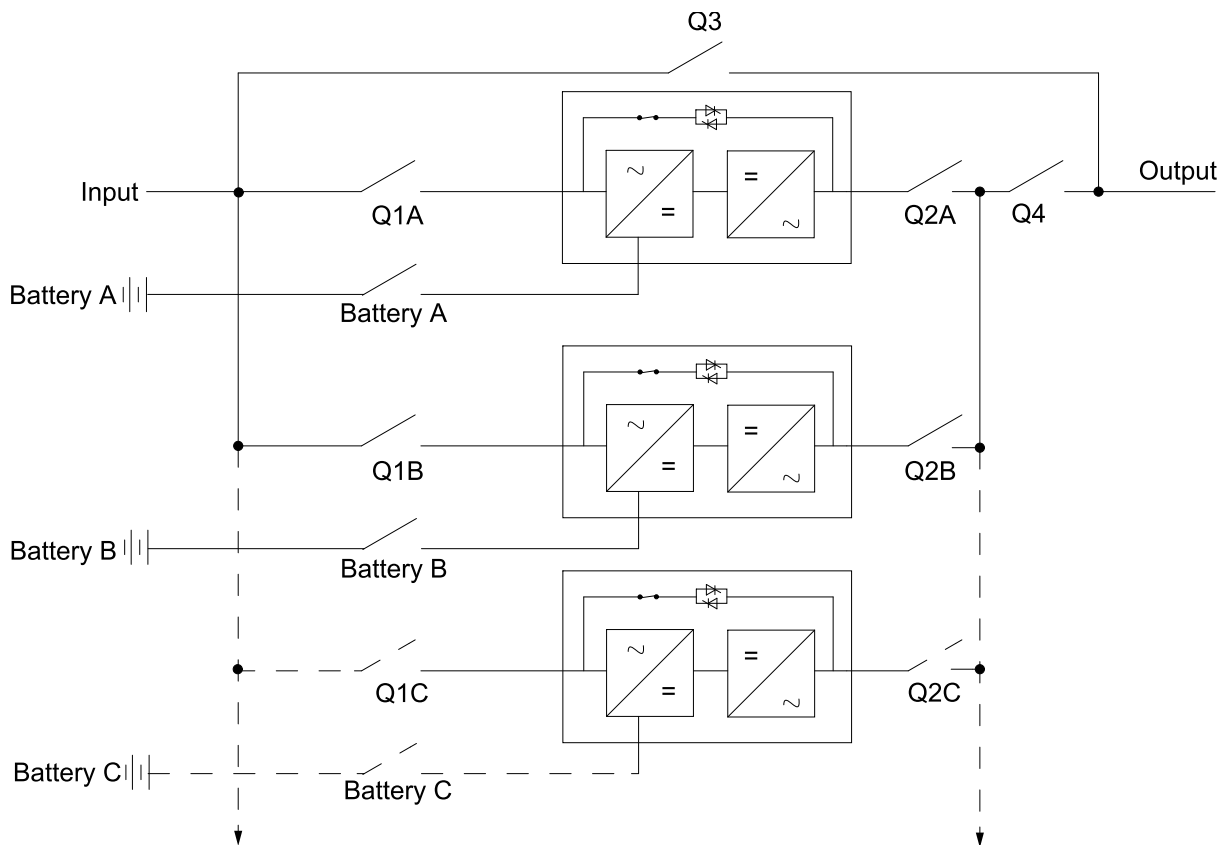

Dual Utility/Mains

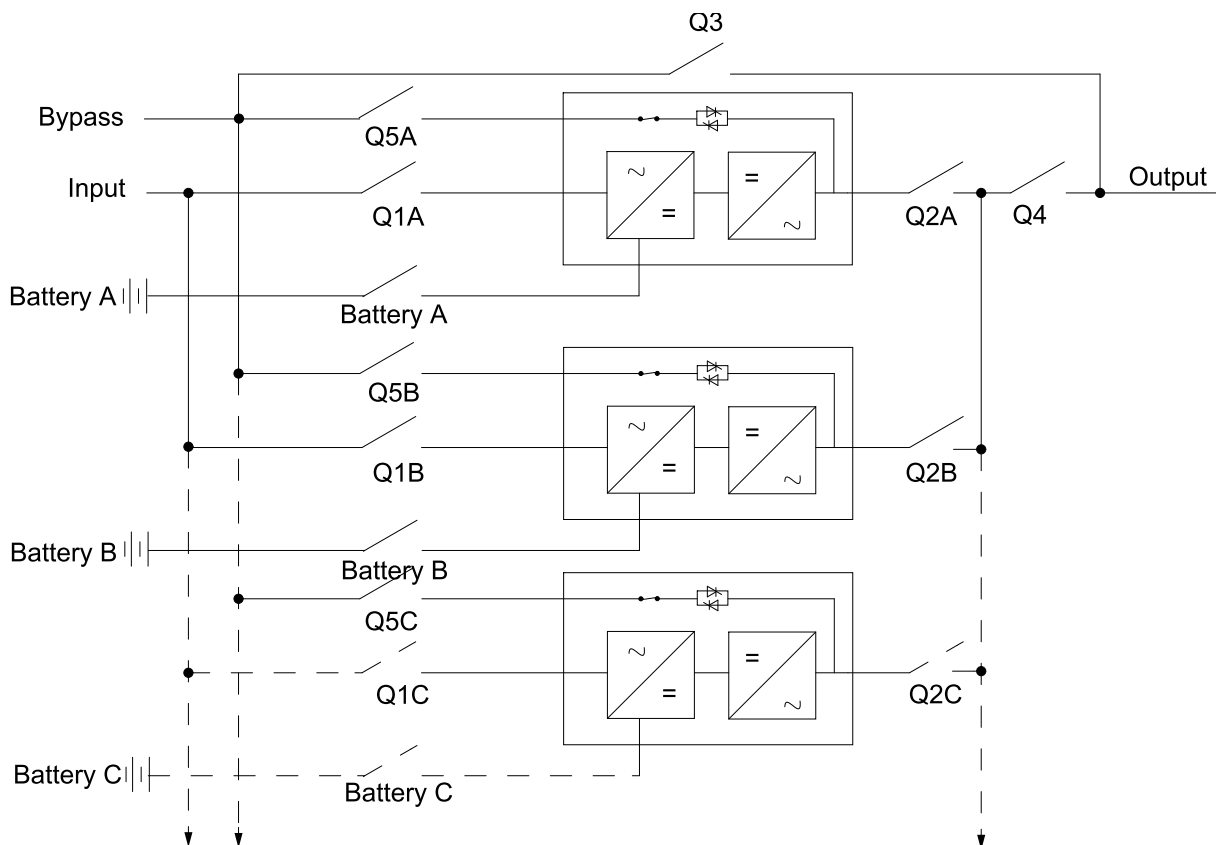

UL-Specific Specifications

Recommended Fuses, Breakers, and Cables for UL

In single utility/mains systems, supply the UPS from a grounded 4–wire WYE service.

Schneider Electric also supports 3–wire installations if the utility/mains transformer is a grounded WYE transformer located in the same building. In this installation, the UPS system must be installed as a separately derived system. Leakage currents will occur in the bonding jumper and the technical/system earth.

In dual utility/mains systems, use a 4–wire supply for the bypass and a 3–wire supply for the input. Both must be WYE sources. Delta input supply for either input or bypass is not permitted.

NOTICE
HAZARD OF EQUIPMENT DAMAGE
In 3–wire systems, Schneider Electric recommends that you add a label with the following wording: “Notice! The UPS is installed as a 3–wire system so the system must only be loaded with phase-to-phase load.”
Failure to follow these instructions can result in equipment damage.

NOTE: 3–wire installations using bonding wire will result in a higher leakage current. Leakage current for a typical installation is usually within UL and industry standard requirements.

Parallel Systems

NOTE: For parallel systems, the cable lengths for bypass and output must be the same for all parallel UPS units to ensure correct load sharing in bypass operation. In single utility/mains installations this applies to input cables.

Schneider Electric recommends that the Symmetra PX 250/500 kW parallel system is supplied from a grounded 4–wire WYE service.

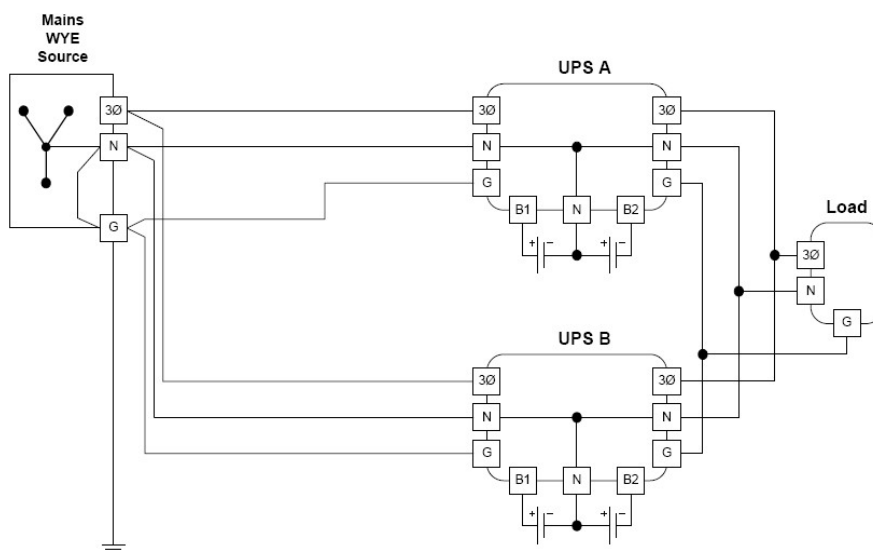

However if the load is a 3–phase load, the three alternatives below for 3–wire installations are allowed:

NOTICE

HAZARD OF MALFUNCTIONING

Phase-Neutral loading is not permitted.

Failure to follow these instructions can result in equipment damage.

- Connect an N-G bond in each UPS, and connect the UPS output ground via tap conductors to a common grounded electrode bus and a single grounding electrode conductor. See NEC 250.30 (A)(4), including Exception #1.

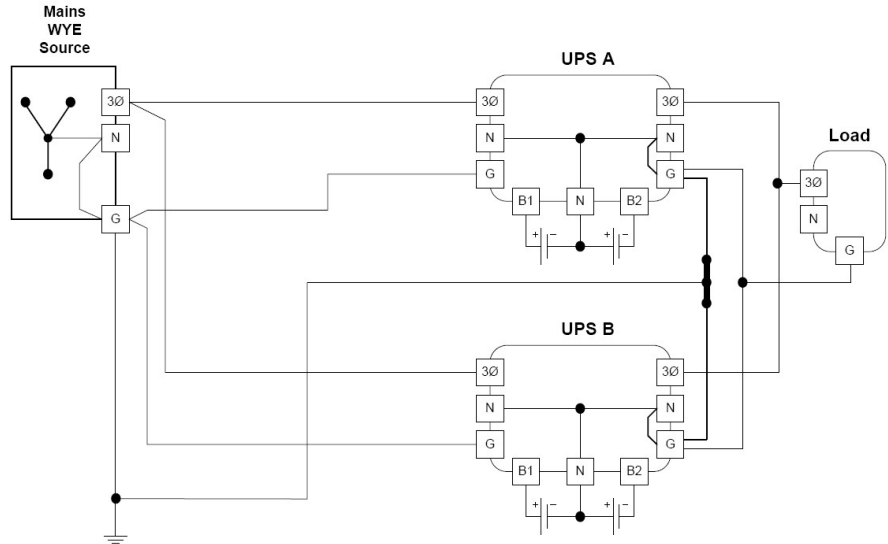

- Connect an N-G bond in each UPS, and connect the UPS output neutral via tap conductors to a common grounded electrode bus and a single grounding electrode conductor. See NEC 250.30 (A)(4), including Exception #1.

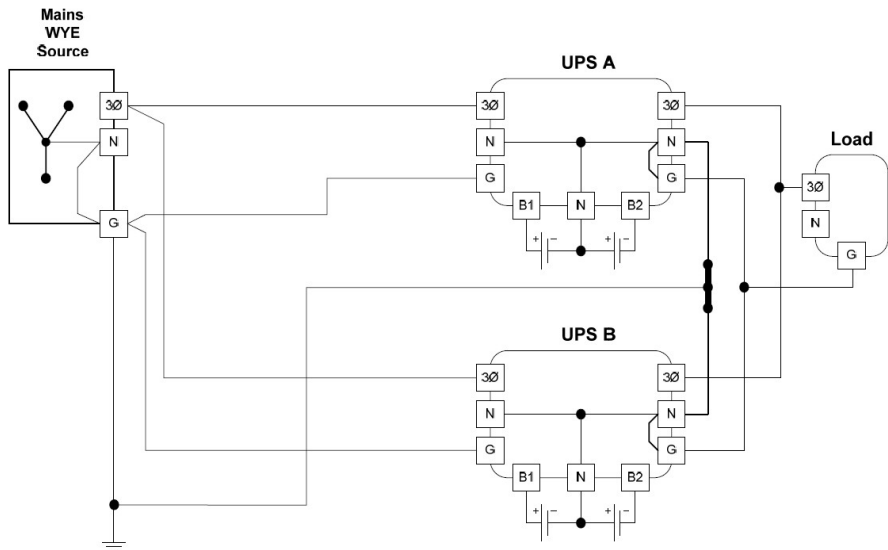

- Connect an output neutral from each UPS to a neutral/bonding bus in the maintenance bypass panel, and bond the maintenance bypass panel neutral bus to the ground with a single N-G bonding jumper and a grounding electrode conductor. See NEC 250.30 (A) Exception #1.

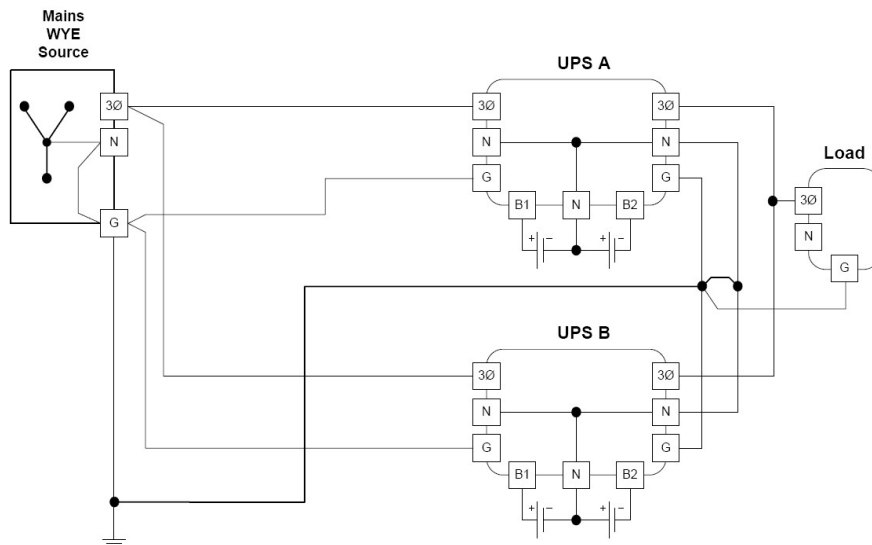

NOTE: Schneider Electric recommends that each UPS in the parallel system has a neutral connection installed. Contact Schneider Electric for information on other configurations.

Recommended Fuses, Breakers, and Cable Sizes

⚠ DANGER

HAZARD OF ELECTRIC SHOCK, EXPLOSION, OR ARC FLASH

The product must be installed according to the specifications and requirements as defined by Schneider Electric. It concerns in particular the external and internal protections (upstream circuit breakers, battery circuit breakers, cabling, etc.) and environmental requirements. No responsibility is assumed by Schneider Electric if these requirements are not respected.

Failure to follow these instructions will result in death or serious injury.

⚠ DANGER

HAZARD OF ELECTRIC SHOCK, EXPLOSION OR ARC FLASH

All wiring must comply with all applicable national and/or local electrical codes.

Failure to follow these instructions will result in death or serious injury.

⚠ DANGER

HAZARD OF ELECTRIC SHOCK, EXPLOSION OR ARC FLASH

Appropriate disconnect devices must be provided external to the equipment.

Failure to follow these instructions will result in death or serious injury.

NOTE: See Required Breaker Settings for Input Overload and Short-Circuit Protection for Breakers with Electronic Trip Units, page 38 for information on breaker settings.

NOTE: All wiring must comply with all applicable national and/or electrical code (National Electrical Code, ANSI/NFPA 70).

Cable sizes in this manual are based on Table 310.15 of the National Electrical Code 2014 (NEC) with the following assertions:

- 90 °C conductors (THHN) for 75 °C termination
- Not more than 3 current carrying conductors in each conduit
- An ambient temperature of max. 30 °C

- Use of copper or aluminium conductors
- 100% rated breakers
- Nominal operating conditions

If the ambient room temperature is greater than 30 °C, use larger or additional parallel conductors in accordance with the correction factors of the NEC. The maximum allowable conductor size is 600 kcmil.

Equipment Grounding Conductors (EGC) are sized in accordance with NEC Article 250.122 and Table 250.122 Minimum size equipment conductor for grounding equipment.

NOTE: Always consider the EGC size according to the complete electrical installation.

NOTE: The use of aluminium conductors can limit the number of parallel Lithium-ion battery cabinets. Contact Schneider Electric for more information.

The cable sizes are recommendations for maximum configurations with three current carrying conductors in a raceway. For other configurations see the label inside the front door of the I/O cabinet.

NOTE: A separate 800 A protection device for bypass (similar to dual utility/mains) is required for single utility/mains systems from 450 kW 400 V or 475 kW 415 V.

Installations with 100% Rated Circuit Breakers or Fuses

250 kW						
	400 V		415 V		480 V	
	OCPD (A)	Cable	OCPD (A)	Cable	OCPD (A)	Cable
Input Q1	450	2 x 4/0	450	2 x 4/0	400	1 x 500
Bypass Q5 ⁷	400	2 x 2/0	350	2 x 2/0	350	2 x 2/0
Battery ⁸	500	2 x 4/0	500	2 x 4/0	500	2 x 4/0
Output Q2	400	1 x 500	350	1 x 500	350	1 x 350

Use breaker or class J or class L fuses.

Installations with 100% Rated Circuit Breakers or Fuses

500 kW						
	400 V		415 V		480 V	
	OCPD (A)	Cable	OCPD (A)	Cable	OCPD (A)	Cable
Input Q1	1000	3 x 400	1000	3 x 400	800	2 x 500
Bypass Q5 ⁷	800	3 x 250	700	3 x 250	700	3 x 4/0
Battery ⁸	1000	3 x 400	1000	3 x 400	1000	3 x 400
Output Q2	800	2 x 500	700	2 x 500	700	2 x 350

Use breaker or class J or class L fuses.

Installations with 80% Rated Circuit Breakers

250 kW						
	400 V		415 V		480 V	
	OCPD (A)	Cable	OCPD (A)	Cable	OCPD (A)	Cable
Input Q1	600	2 x 300	600	2 x 250	450	2 x 4/0
Bypass Q5 ⁷	500	2 x 4/0	450	2 x 4/0	400	2 x 3/0

7. Maximum input protection is 800 A and the maximum cable size is 250 kcmil.

8. If the UPS system includes a battery breaker cabinet and has one or multiple battery strings, each individual string must have a correctly sized fast fuse installed for correct isolation of the battery.

Installations with 80% Rated Circuit Breakers (Continued)

250 kW						
	400 V		415 V		480 V	
	OCPD (A)	Cable	OCPD (A)	Cable	OCPD (A)	Cable
Battery ⁹	500	2 x 4/0	500	2 x 4/0	500	2 x 4/0
Output Q2	500	2 x 4/0	450	2 x 4/0	400	1 x 500

Installations with 80% Rated Circuit Breakers

500 kW						
	400 V		415 V		480 V	
	OCPD (A)	Cable	OCPD (A)	Cable	OCPD (A)	Cable
Input Q1	1200	4 x 350	1200	4 x 350	1000	3 x 400
Bypass Q5 ¹⁰	Not allowed		Not allowed		800	3 x 250
Battery ⁹	1000	3 x 400	1000	3 x 400	1000	3 x 400
Output Q2	Not allowed		Not allowed		800	2 x 500

Typical Q3 and Q4 Breaker Sizes for Parallel Systems

250 kW units in parallel						
	400 V		415 V		480 V	
OCPD Rating	80%	100%	80%	100%	80%	100%
500 kW	1000	800	1000	700	800	700
750 kW	1600	1200	1600	1200	1200	1000
1 MW	2000	1600	2000	1600	1600	1600
1.5 MW	-	-	-	-	-	-
2 MW	-	-	-	-	-	-

Typical Q3 and Q4 Breaker Sizes for Parallel Systems

500 kW units in parallel						
	400 V		415 V		480 V	
OCPD Rating	80%	100%	80%	100%	80%	100%
500 kW	-	-	-	-	-	-
750 kW	-	-	-	-	-	-
1 MW	2000	1600	2000	1600	1600	1600
1.5 MW	3000	2500	3000	2500	2500	2000
2 MW	4000	3000	4000	3000	4000	2500

Recommended Bolt and Lug Sizes for UL

Cable size	Terminal bolt diameter	Single Hole lug	NEMA 2 Lug	Crimping tool/die
4/0 AWG	M10	LCA 4/0-12-X	LCD 4/0-12-X	CT-720/CD-720-3
250 kcmil	M10	LCA250-12-X	LCD250-12-X	CT-720/CD-720-3
300 kcmil	M10	LCA300-12-X	LCD300-12-X	CT-720/CD-720-4
350 kcmil	M10	LCA350-12-X	LCD350-12-X	CT-720/CD-720-5

- 9. If the UPS system includes a battery breaker cabinet and has one or multiple battery strings, each individual string must have a correctly sized fast fuse installed for correct isolation of the battery.
- 10. Maximum input protection is 800 A and the maximum cable size is 250 kcmil.

Cable size	Terminal bolt diameter	Single Hole lug	NEMA 2 Lug	Crimping tool/die
400 kcmil	M10	LCA400-12-6	LCD400-12-6	CT-720/CD-720-6
500 kcmil	M10	LCA500-12-6	LCD500-12-6	CT-720/CD-720-7

IEC-Specific Specifications

Surge Protection Device (SPD)

⚠ DANGER

HAZARD OF ELECTRIC SHOCK, EXPLOSION, OR ARC FLASH

This UPS is OVCII (Over Voltage Category Class II) compliant. This UPS must only be installed in an OVCII compliant environment.

- If the UPS is installed in an environment with an OVC rating higher than II, an SPD (surge protection device) must be installed upstream of the UPS to reduce the overvoltage category to OVCII.
- The SPD must include a status indicator to show the user if the SPD is operational or is no longer functioning according to design. The status indicator may be visual and/or audible and/or may have remote signalling and/or output contact capability in accordance with IEC 62040-1.

Failure to follow these instructions will result in death or serious injury.

Surge Protection Device Requirements

Select a surge protection device that complies with the following requirements:

Class	Type 2
Rated voltage (Ur)	230/400 V, 277/480 V
Voltage protection level (Up)	< 2.5 kV
Short circuit rating (Iscsr) ¹¹	According to installation prospective short circuit level
Earthing system ¹²	TN-S, TT, IT, TN-C
Poles	3P/4P depending on earthing configuration
Standards	IEC 61643-11 / UL 1449
Monitoring	Yes

11. Lower short circuit rating can be achieved with fuse protection.

12. Corner grounding not permitted.

Upstream and Downstream Protection for IEC

⚠️⚠️ DANGER
<p>HAZARD OF ELECTRIC SHOCK, EXPLOSION, OR ARC FLASH</p> <ul style="list-style-type: none"> • Circuit breakers must have instantaneous trip time of maximum 60 ms. • Circuit breakers must have instantaneous override values set according to the table below. • Circuit breakers must be installed for input (unit input breaker UIB) and bypass (static switch input breaker SSIB). • For parallel system with three or more UPSs: Circuit breakers must be installed for the output (unit output breaker UOB) of each UPS. The unit output breaker (UOB) is sized as the static switch input breaker (SSIB). <p>Failure to follow these instructions will result in death or serious injury.</p>

NOTICE
<p>If a residual current-operated protective device (RCD-B) is used upstream as ground fault protection, then the RCD-B shall be sized to not trip on the leakage current of this product, which can be up to 303 mA.</p> <p>Failure to follow these instructions can result in equipment damage.</p>

Upstream Protection for IEC and Minimum Prospective Phase-To-Earth Short Circuit at the UPS Input/Bypass Terminals

The minimum prospective phase-to-earth short circuit current required at the UPS terminals is dependent on the upstream overcurrent protection device and its settings to ensure proper operation and required operation time, in case of a short circuit between one of the phases and the metal enclosure of the UPS.

⚠️ DANGER
<p>HAZARD OF ELECTRIC SHOCK, EXPLOSION, OR ARC FLASH</p> <p>The upstream overcurrent protective device (and its settings) must be sized to ensure a disconnecting time within 0.2 seconds for a minimum prospective phase-to-earth short circuit current calculated or measured at the input/bypass terminals of the UPS.</p> <p>Failure to follow these instructions will result in death or serious injury.</p>

If the upstream overcurrent protective device is a breaker with adjustable short time protection, then it is possible to adjust the short time protection current and short time delay (if present) to meet the requirement of 0.2 seconds for a calculated or measured phase-to-earth prospective short circuit current at the input/bypass terminals of the UPS.

Recommended Fuses, Breakers, and Cables for IEC

⚠ DANGER

HAZARD OF ELECTRIC SHOCK, EXPLOSION, OR ARC FLASH

The product must be installed according to the specifications and requirements as defined by Schneider Electric. It concerns in particular the external and internal protections (upstream circuit breakers, battery circuit breakers, cabling, etc.) and environmental requirements. No responsibility is assumed by Schneider Electric if these requirements are not respected.

Failure to follow these instructions will result in death or serious injury.

⚠ DANGER

HAZARD OF ELECTRIC SHOCK, EXPLOSION OR ARC FLASH

All wiring must comply with all applicable national and/or local electrical codes.

Failure to follow these instructions will result in death or serious injury.

⚠ DANGER

HAZARD OF ELECTRIC SHOCK, EXPLOSION OR ARC FLASH

Appropriate disconnect devices must be provided external to the equipment.

Failure to follow these instructions will result in death or serious injury.

NOTE: For parallel systems, the cable lengths for bypass and output must be the same for all parallel UPS units to ensure correct load sharing in bypass operation. In single utility/mains installations this applies to input cables.

NOTE: See Required Breaker Settings for Input Overload and Short-Circuit Protection for Breakers with Electronic Trip Units, page 38 for information on breaker settings.

Supply the UPS from a 5-wire TN-S system (L1, L2, L3, N, PE).

Cable sizes in this manual are based on table B.52.12 and B.52.13 of IEC 60364-5-52 with the following assertions:

- 90 °C conductors
- An ambient temperature of 30 °C
- Use of copper or aluminium conductors
- Installation method F4 for DC cables and installation method F5 for AC cables, corrected for single layer in perforated cable tray

PE cables are sized in accordance with IEC 60364-5-54 table 54.2 Minimum cross-sectional area of protective conductors.

NOTE: Always consider the PE size according to the complete electrical installation. Minimum size of the PE conductor must comply with local safety regulations for high PE conductor current equipment.

If the ambient temperature is greater than 30 °C, larger conductors are to be selected in accordance with the correction factors of the IEC.

Refer to IEC 60364-5-52 for installation methods. The cable sizes are recommendations for maximum configurations and copper cables. For other system size configurations see label inside of I/O cabinet front door.

Recommended Cable Sizes in Systems with Breaker Protection

Installation method	OCPD (A)	B1 (mm ²)	B2 (mm ²)	C (mm ²)	OCPD (A)	B1 (mm ²)	B2 (mm ²)	C (mm ²)
	400 V				415 V			
	250 kW							
Input	400 ¹	2 x 95	2 x 120	2 x 95	400 ¹³	2 x 95	2 x 120	2 x 95
Bypass	400	2 x 95	2 x 120	2 x 95	355	2 x 95	2 x 120	2 x 95
Battery ¹⁴	500	1 x 120	3 x 95	2 x 95	500	1 x 120	3 x 95	2 x 95
Output	400	2 x 95	2 x 120	2 x 95	355	2 x 95	2 x 120	2 x 95
	500 kW							
Input	800	4 x 120	-	3 x 150	800 ¹³	4 x 120	-	3 x 150
Bypass	800	4 x 120	-	3 x 150	800	4 x 120	-	3 x 150
Battery ¹⁴	1000	-	-	3 x 240	1000	-	-	3 x 240
Output	800	4 x 120	-	3 x 150	800	4 x 120	-	3 x 150

Recommended Cable Sizes in Systems with Fuse Protection

Installation method	OCPD (A)	B1 (mm ²)	B2 (mm ²)	C (mm ²)	OCPD (A)	B1 (mm ²)	B2 (mm ²)	C (mm ²)
	400 V				415 V			
	250 kW							
Input	500	2 x 95	2 x 120	2 x 150	400 ¹⁵	2 x 95	2 x 120	2 x 95
Bypass	400	2 x 95	2 x 120	2 x 95	355	2 x 95	2 x 95	1 x 185
Battery ¹⁴	500	1 x 120	3 x 95	2 x 95	500	1 x 120	3 x 95	2 x 95
Output	400	2 x 95	2 x 120	2 x 95	355	2 x 95	2 x 95	1 x 185
	500 kW							
Input	1000	-	-	4 x 150	1000	-	-	4 x 150
Bypass ¹⁵	800	4 x 120	-	3 x 150	800	4 x 120	-	3 x 150
Battery ¹⁴	1000	-	-	3 x 240	1000	-	-	3 x 240
Output	800	4 x 120	-	3 x 150	800	4 x 120	-	3 x 150

Typical Q3 and Q4 Breaker Sizes for Parallel Systems

	250 kW		500 kW	
	400 V	415 V	400 V	415 V
For 2 UPS units (A)	800	800	1600	1600
For 3 UPS units (A)	1250	1250	2500	2000
For 4 UPS units (A)	1600	1600	3200	3200

13. The breaker must comply with IEC 60947-2 which guarantees a non-tripping current of 1.05 times current setting for 2 hours. Alternative breaker size must be higher than stated current.
 14. If the UPS system includes a battery breaker cabinet and has one or multiple battery strings, each individual string must have a correctly sized fast fuse installed for correct isolation of the battery.
 15. Maximum input protection is 800 A.

Recommended Bolt and Lug Sizes for IEC

Cable size mm ²	Bolt size	Cable lug type
16	M10 x 40 mm	TLK 16-10
25	M10 x 40 mm	TLK 25-10
35	M10 x 40 mm	TLK 35-10
50	M10 x 40 mm	TLK 50-10
70	M10 x 40 mm	TLK 70-10
95	M10 x 40 mm	TLK 95-10
120	M10 x 40 mm	TLK 120-10
150	M10 x 40 mm	TLK 150-10
185	M10 x 40 mm	TLK 185-10
240	M10 x 40 mm	TLK 240-10

Required Breaker Settings for Input Overload and Short-Circuit Protection for Breakers with Electronic Trip Units

Single Utility/Mains Installation (Common Input and Bypass Breaker)

	Input Breaker
In	Maximum input current
STPU	$In \times A$ ($3 < A < 4$)
STD	Maximum 100 ms
LTD	Maximum $3 \times In$ in 5s
linst	$In \times 5$

Dual Utility/Mains Installation (Separate Input and Bypass Breaker)

	Input Breaker	Bypass Breaker
In	Maximum input current	Maximum input current
STPU	$In \times A$ ($3 < A < 4$)	$In \times B$ ($10 < B < 12$)
STD	Maximum 100 ms	Maximum 100 ms
LTD	Maximum $3 \times In$ in 5s	Maximum $3 \times In$ in 5s
linst	$In \times 5$	$In \times 15$

Torque Specifications

Bolt size M8	Bolt size M10
13.5 Nm	30 Nm

Physical

Weights and Dimensions

Modules	Weight kg (lbs)
Power module (SYPM25KD)	42 (92)
Battery unit (SYBTU2-PLP, SYBTU2-PLPLL)	25.5 (56)
Static bypass switch 250kVA (SYSW250KD)	79 (174)
Static bypass switch 500kVA (SYSW500KD)	108 (238)

Cabinets	Weight kg (lbs)
I/O cabinet (SYIOF500KD)	332 (730)
I/O cabinet with maintenance bypass (SYIOF500KMBR)	695 (1529)
Power module cabinet (SYPF250KD)	243 (535)
Battery cabinet (SYBFXR8)	374 (822)
Bottom feed cabinet (SYBFF)	150 (330)
Battery side car (SYBSC)	149 (328)
Battery breaker cabinet (SYBBE, SYBBE-UL)	327 (719)

Shipping Weights and Dimensions

Modules	Weight kg (lbs)	Height mm (in)	Width mm (in)	Depth mm (in)
Power module (SYPM25KD)	48 (106)	285 (11.22)	585 (23.03)	935 (36.81)
Battery unit (SYBTU2-PLP, SYBTU2-PLPLL)	27 (60)	178 (7.08)	108 (4.25)	610 (24)
Static bypass switch 250kVA (SYSW250KD)	105 (231)	930 (36.61)	780 (30.71)	915 (36.02)
Static bypass switch 500kVA (SYSW500KD)	134 (295)	930 (36.61)	780 (30.71)	915 (36.02)

Cabinets	Weight kg (lbs)	Height mm (in)	Width mm (in)	Depth mm (in)
I/O cabinet (SYIOF500KD)	375 (827)	2135 (84.06)	745 (29.33)	1210 (47.64)
I/O cabinet with maintenance bypass (SYIOF500KMBR)	752 (1658)	2150 (84.65)	1120 (44.09)	1270 (50)
Power module cabinet (SYPF250KD)	280 (617)	2135 (84.06)	750 (29.53)	1210 (47.64)
Battery cabinet (SYBFXR8)	431 (950)	2150 (84.65)	1120 (44.09)	1270 (50)
Bottom feed cabinet (SYBFF)	186 (410)	2135 (84.06)	745 (29.33)	1210 (47.64)
Battery side car (SYBSC)	185 (408)	2150 (84.65)	745 (29.33)	1210 (47.64)
Battery breaker cabinet (SYBBE, SYBBE-UL)	365 (805)	2135 (84.06)	750 (29.53)	1210 (47.64)

Clearance

⚠ DANGER

HAZARD OF ELECTRIC SHOCK, EXPLOSION OR ARC FLASH

The required free space to other equipment containing live parts is 1219 mm (48 in).

Failure to follow these instructions will result in death or serious injury.

NOTE: Clearance dimensions are published for airflow and service access only. Consult with the local safety codes and standards for additional requirements in your local area.

The UPS system can be placed up against the wall as there is no requirement for rear access. However, if the UPS system installation is done in a manner that prevents rolling a cabinet forward and into a position where service can be performed, rear service access is required. In these cases, recommended clearance between the rear of the cabinet and the wall is 1070 mm (42 in). Examples of these cases would be installation on a housekeeping pad that elevates the UPS off the floor by 100 mm (4 in) or cabinets with bottom cable entry.

Symmetra PX 250/500 kW without Maintenance Bypass

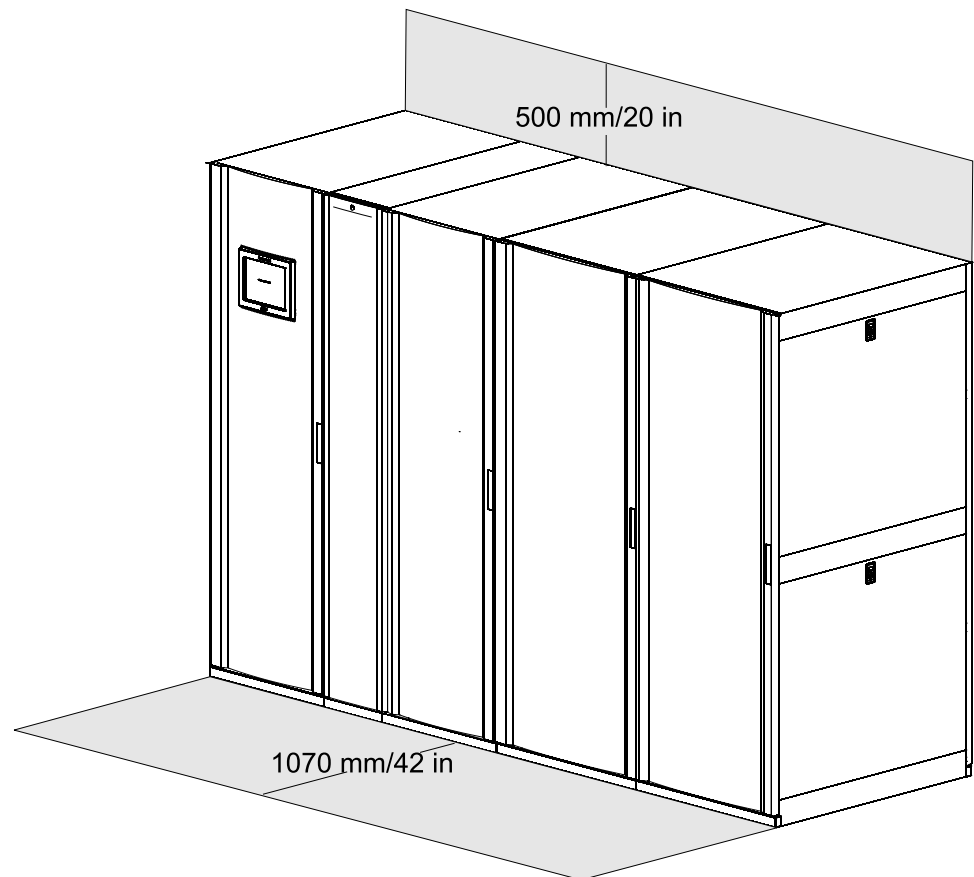

Symmetra PX 250/500 kW with Maintenance Bypass

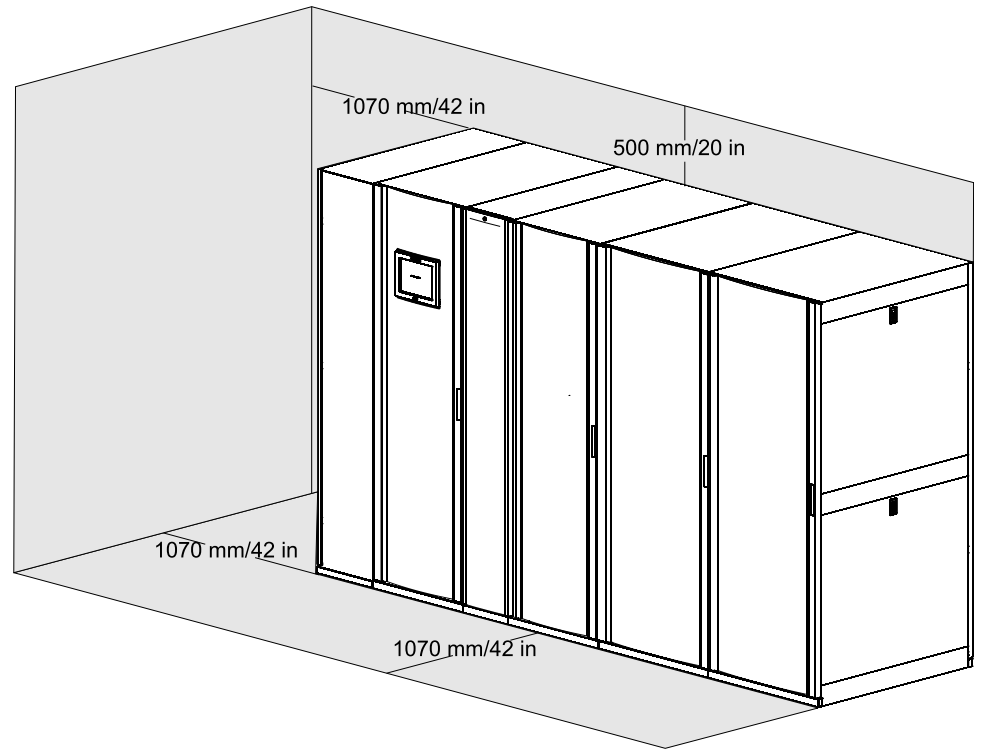

Environmental

Operating Temperature	0 to 40° C
Storage Temperature	-15 to 40° C for systems with batteries -30 to 70° C for systems without batteries
Operating Relative Humidity	0 - 95%
Storage Relative Humidity	0 - 95%
Operating Elevation	0-1000 m: 100% load 1000–1500 m: 95% load 1500–2000 m: 91% load 2000–2500 m: 86% load 2500–3000 m: 82% load
Storage Elevation	0-15000 meters
Audible noise at 1 meter from surface of unit @ 25° C	480 V 100% load: <54 dBA 480 V 70% load: <45 dBA 400 V 100% load: <60 dBA 400 V 70% load: <49 dBA
Protection Class	NEMA 1, IP 20
Colour	Black

Heat Dissipation

	100 kW	125 kW	150 kW	175 kW	200 kW	225 kW	250 kW	275 kW	300 kW
Heat dissipation ¹⁶ (BTU/hr)	14 217	17 771	21 325	24 879	28 433	31 968	35 542	39 096	42 650
Heat dissipation ¹⁷ (BTU/hr)	17 103	21 379	25 655	29 931	34 207	38 483	42 759	47 035	51 310

	325 kW	350 kW	375 kW	400 kW	425 kW	450 kW	475 kW	500 kW
Heat dissipation ¹⁶ (BTU/hr)	46 204	49 758	53 313	56 867	60 421	63 975	67 529	71 083
Heat dissipation ¹⁷ (BTU/hr)	55 586	59 852	64 138	68 414	72 690	76 966	81 241	85 517

16. Batteries fully charged
17. Batteries charging

Drawings

NOTE: A comprehensive set of drawings is available on www.se.com.

NOTE: These drawings are for reference ONLY – subject to change without notice.

Symmetra PX 500 kW 400 V Single Utility/Mains with Maintenance Bypass and Line-Up-And-Match Batteries – Bottom Feed

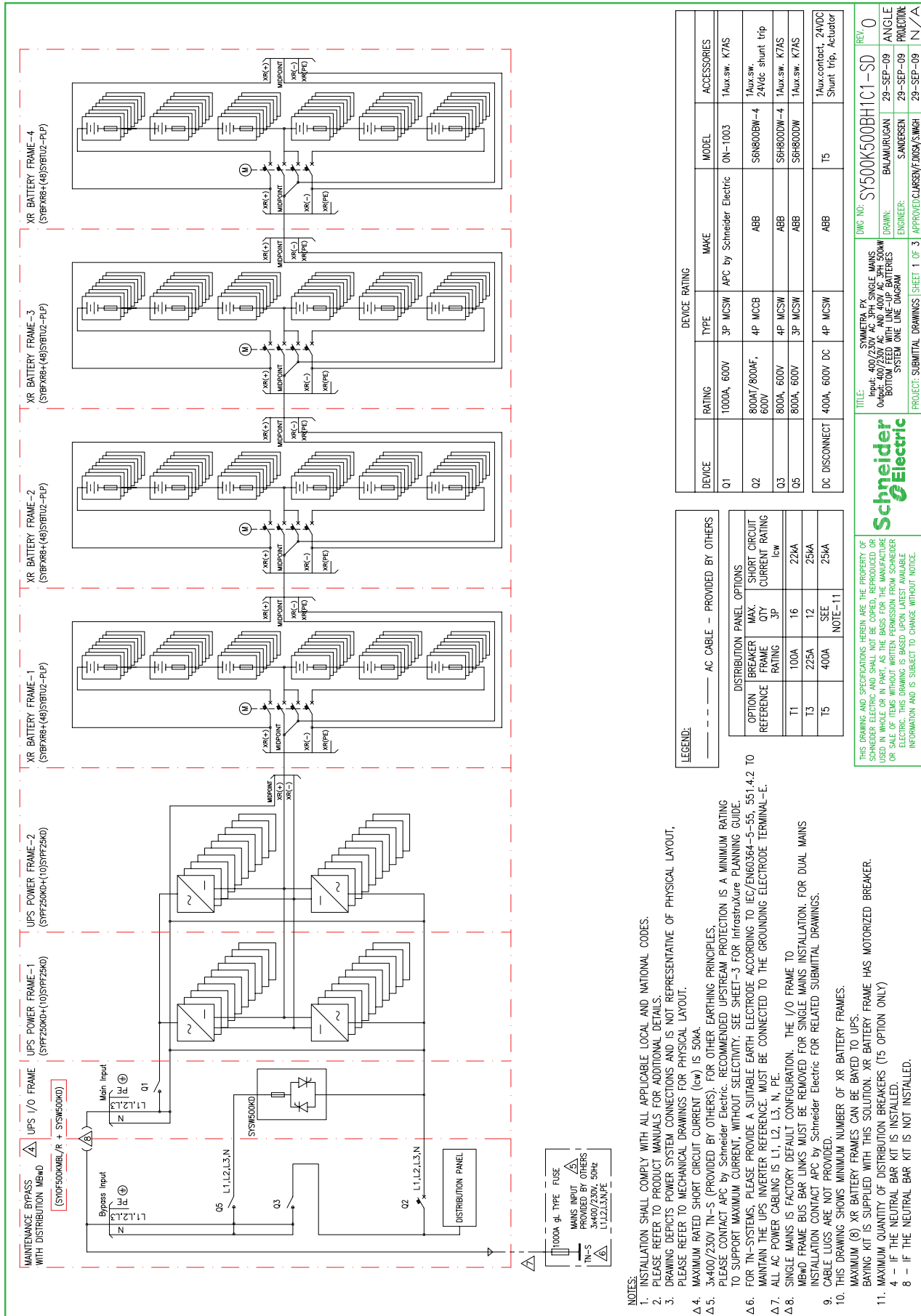

LEGEND: --- AC CABLE - PROVIDED BY OTHERS

DEVICE	RATING	TYPE	MAKE	MODEL	ACCESSORIES
01	1000A, 600V	3P MCSW	APC by Schneider Electric	ON-1003	1Aux.sw. K7AS
02	800A/800AF, 600V	4P MCCB	ABB	S6N800BW-4	1Aux.sw. 24Vdc shunt trip
03	800A, 600V	4P MCSW	ABB	S6H800DW-4	1Aux.sw. K7AS
05	800A, 600V	3P MCSW	ABB	S6H800DW	1Aux.sw. K7AS
DC DISCONNECT	400A, 600V DC	4P MCSW	ABB	T5	1Aux.contact, 24VDC Shunt trip, Actuator

LEGEND: --- AC CABLE - PROVIDED BY OTHERS

DISTRIBUTION PANEL OPTION	BREAKER REFERENCE	MAX. QTY	SHORT CIRCUIT CURRENT RATING	
			3P	1ew
T1	100A	16	22kA	
T3	225A	12	25kA	
T5	400A	SEE NOTE-11	25kA	

Schneider Electric

THIS DRAWING AND SPECIFICATIONS HEREIN ARE THE PROPERTY OF SCHNEIDER ELECTRIC, AND SHALL NOT BE COPIED, REPRODUCED OR USED IN WHOLE OR IN PART, AS THE BASIS FOR THE MANUFACTURE OR SALE OF ITEMS WITHOUT WRITTEN PERMISSION FROM SCHNEIDER ELECTRIC. THIS DRAWING IS BASED UPON LATEST AVAILABLE INFORMATION AND IS SUBJECT TO CHANGE WITHOUT NOTICE.

TITLE: SYMMETRA PX SINGLE MAINS INPUT: 400/230V AC, 3PH, 50/60HZ OUTPUT: 400/230V AC AND 480V AC, 3PH, 50/60HZ BOTTOM FEED WITH LINE-UP AND MATCH BATTERIES SYSTEM ONE LINE DIAGRAM

DWG. NO: SY500K500BH1C1-S0 REV: 0

PROJECT: SUBMITTAL DRAWINGS SHEET 1 OF 3 APPROVED: CLAUSEN/FIDUSA/SWGH 29-SEP-09 N/A

ENGINEER: S. ANDERSEN 29-SEP-09

DRAWN: BALAMURUGAN

MODEL: ON-1003

MAKE: APC by Schneider Electric

TYPE: 3P MCSW

RATING: 1000A, 600V

ACCESSORIES: 1Aux.sw. K7AS

- NOTES:
- INSTALLATION SHALL COMPLY WITH ALL APPLICABLE LOCAL AND NATIONAL CODES.
 - PLEASE REFER TO PRODUCT MANUALS FOR ADDITIONAL DETAILS.
 - DRAWING DEPICTS POWER SYSTEM CONNECTIONS AND IS NOT REPRESENTATIVE OF PHYSICAL LAYOUT. PLEASE REFER TO MECHANICAL DRAWINGS FOR PHYSICAL LAYOUT.
 - MAXIMUM RATED SHORT CIRCUIT CURRENT (I_{sc}) IS 50kA.
 - 3x400/230V TN-S (PROVIDED BY OTHERS). FOR OTHER EARTHING PRINCIPLES, PLEASE CONTACT APC BY SCHNEIDER ELECTRIC. RECOMMENDED UPSTREAM PROTECTION IS A MINIMUM RATING TO SUPPORT MAXIMUM CURRENT, WITHOUT SELECTIVITY. SEE SHEET-3 FOR INFRASTRUCTURE PLANNING GUIDE.
 - FOR TN-S SYSTEMS, PLEASE PROVIDE A SUITABLE EARTH ELECTRODE ACCORDING TO IEC/EN60364-5-55, 551.4.2 TO MAINTAIN THE UPS INVERTER REFERENCE IS L1, L2, L3, N, PE.
 - ALL AC POWER CABLING IS L1, L2, L3, N, PE.
 - SINGLE MAINS IS FACTORY DEFAULT CONFIGURATION. THE I/O FRAME TO MEND FRAME BUS LINKS MUST BE REMOVED FOR SINGLE MAINS INSTALLATION. FOR DUAL MAINS INSTALLATION CONTACT APC BY SCHNEIDER ELECTRIC FOR RELATED SUBMITTAL DRAWINGS.
 - CABLE LUGS ARE NOT PROVIDED.
 - THIS DRAWING SHOWS MINIMUM NUMBER OF XR BATTERY FRAMES. MAXIMUM (8) XR BATTERY FRAMES CAN BE BAYED TO UPS. BAYING KIT IS SUPPLIED WITH THIS SOLUTION. XR BATTERY FRAME HAS MOTORIZED BREAKER.
 - MAXIMUM QUANTITY OF DISTRIBUTION BREAKERS (T5 OPTION ONLY) 4 - IF THE NEUTRAL BAR KIT IS INSTALLED. 8 - IF THE NEUTRAL BAR KIT IS NOT INSTALLED.

Symmetra PX 500 kW 400 V Single Utility/Mains with Maintenance Bypass and Line-Up-And-Match Batteries – Top Feed

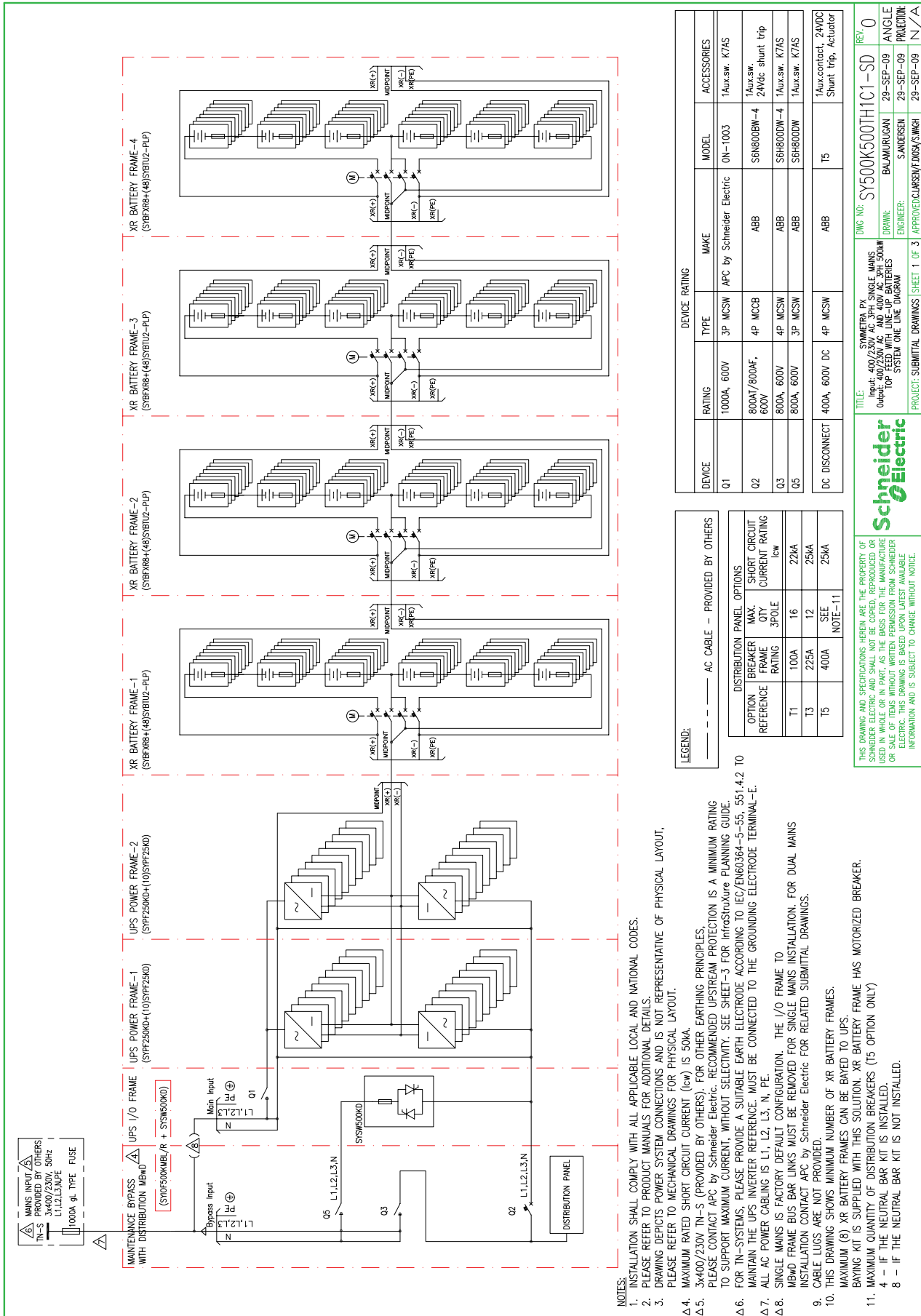

DEVICE	RATING	TYPE	MAKE	MODEL	ACCESSORIES
Q1	1000A, 600V	3P MCSW	APC by Schneider Electric	ON-1003	1Aux.sw. K7AS
Q2	800AT/800AF, 600V	4P MCCB	ABB	SB800BW-4	1Aux.sw. 24Vdc shunt trip
Q3	800A, 600V	4P MCSW	ABB	SBH800DW-4	1Aux.sw. K7AS
Q5	800A, 600V	3P MCSW	ABB	SBH800DW	1Aux.sw. K7AS
DC DISCONNECT	400A, 600V DC	4P MCSW	ABB	T5	1Aux.contact, 24VDC Shunt trip, Actuator

TITLE: SYMMETRA PX Input: 480/230V AC 3P 3W Single Mains Output: 400/480V AC 3P 3W Top Feed with Line-Up Batteries System One Line Diagram	REV: 0
PROJECT: SUBMITTAL DRAWINGS SHEET 1 OF 3 APPROVED: CLAREV/DKSS/SMH	DATE: 29-SEP-09
ENGINEER: S. SAMERSEN	ANGLE: PROTECTION
DOWN: BALAMURUGAN	PROJECTING: N/A

Schneider Electric

THIS DRAWING AND SPECIFICATIONS HEREIN ARE THE PROPERTY OF SCHNEIDER ELECTRIC AND SHALL NOT BE COPIED, REPRODUCED OR USED IN WHOLE OR IN PART, AS A BASIS FOR THE MANUFACTURE OR REPAIR OF ANY EQUIPMENT, WITHOUT THE WRITTEN PERMISSION OF SCHNEIDER ELECTRIC. THIS DRAWING IS BASED UPON LATEST AVAILABLE INFORMATION AND IS SUBJECT TO CHANGE WITHOUT NOTICE.

- NOTES:**
- INSTALLATION SHALL COMPLY WITH ALL APPLICABLE LOCAL AND NATIONAL CODES.
 - PLEASE REFER TO PRODUCT MANUALS FOR ADDITIONAL DETAILS.
 - DRAWING DEPICTS POWER SYSTEM CONNECTIONS AND IS NOT REPRESENTATIVE OF PHYSICAL LAYOUT, PLEASE REFER TO MECHANICAL DRAWINGS FOR PHYSICAL LAYOUT.
 - MAXIMUM RATED SHORT CIRCUIT CURRENT (I_{sc}) IS 50KA.
 - 3x400/230V TN-S (PROVIDED BY OTHERS). FOR OTHER EARTHING PRINCIPLES, PLEASE CONTACT APC by Schneider Electric. RECOMMENDED UPSTREAM PROTECTION IS A MINIMUM RATING TO SUPPORT MAXIMUM CURRENT, WITHOUT SELECTIVITY. SEE SHEET-3 FOR InfraStruXure PLANNING GUIDE.
 - FOR TN-SYSTEMS, PLEASE PROVIDE A SUITABLE EARTH ELECTRODE ACCORDING TO IEC/EN60364-5-55, 551.4.2 TO MAINTAIN THE UPS INVERTER REFERENCE MUST BE CONNECTED TO THE GROUNDING ELECTRODE TERMINAL-E.
 - ALL AC POWER CABLING IS L1, L2, L3, N, PE.
 - SINGLE MAINS IS FACTORY DEFAULT CONFIGURATION. THE I/O FRAME TO MBWD FRAME BUS BAR LINKS MUST BE REMOVED FOR SINGLE MAINS INSTALLATION. FOR DUAL MAINS INSTALLATION CONTACT APC by Schneider Electric FOR RELATED SUBMITTAL DRAWINGS.
 - CABLE LUGS ARE NOT PROVIDED.
 - THIS DRAWING SHOWS MINIMUM NUMBER OF XR BATTERY FRAMES.
 - MAXIMUM (6) XR BATTERY FRAMES CAN BE BAYED TO UPS BAYING KIT IS SUPPLIED WITH THIS SOLUTION. XR BATTERY FRAME HAS MOTORIZED BREAKER.
 - MAXIMUM QUANTITY OF DISTRIBUTION BREAKERS (15 OPTION ONLY)
 - 4 - IF THE NEUTRAL BAR KIT IS INSTALLED.
 - 8 - IF THE NEUTRAL BAR KIT IS NOT INSTALLED.

Symmetra PX 500 kW 400 V Single Utility/Mains with Maintenance Bypass and Remote Batteries — Top Feed

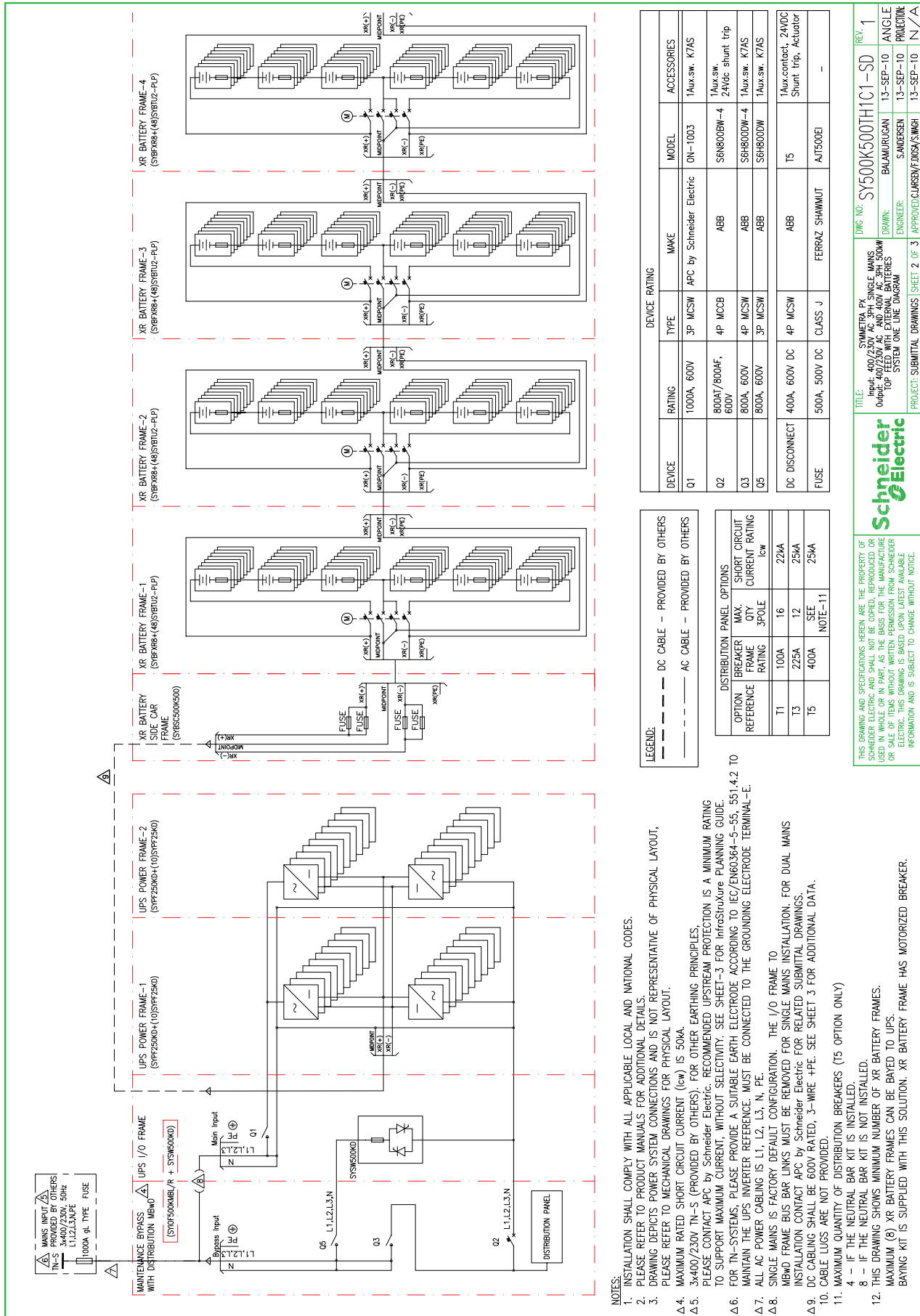

DEVICE	RATING	TYPE	MAKE	MODEL	ACCESSORIES
Q1	1000A, 600V	3P MCSW	APC by Schneider Electric	DN-1003	1Aux.sw. K7AS
Q2	800A/800AF, 600V	4P MCCB	ABB	S6N800BW-4	1Aux.sw. 24Vdc shunt trip
Q3	800A, 600V	4P MCSW	ABB	S6H800DW-4	1Aux.sw. K7AS
Q5	800A, 600V	3P MCSW	ABB	S6H800DW	1Aux.sw. K7AS
DC DISCONNECT	400A, 600V DC	4P MCSW	ABB	T5	1Aux.contact, 24VDC Shunt trip, Actuator
FUSE	500A, 500V DC	CLASS J	FERRAZ SHAWMUT	AJT500E1	-

LEGEND: --- DC CABLE -- PROVIDED BY OTHERS
 --- AC CABLE -- PROVIDED BY OTHERS

DISTRIBUTION PANEL OPTIONS	OPTION REFERENCE	BREAKER FRAME RATING	MAX. QTY 3-POLE	SHORT CIRCUIT CURRENT RATING	
				ICW	ICW
T1	100A	16	22KA		
T3	225A	12	25KA		
T5	400A	SEE NOTE-11	25KA		

- NOTES:
1. INSTALLATION SHALL COMPLY WITH ALL APPLICABLE LOCAL AND NATIONAL CODES.
 2. PLEASE REFER TO PRODUCT MANUALS FOR ADDITIONAL DETAILS.
 3. DRAWING DEPICTS POWER SYSTEM CONNECTIONS AND IS NOT REPRESENTATIVE OF PHYSICAL LAYOUT, PLEASE REFER TO MECHANICAL DRAWINGS FOR PHYSICAL LAYOUT.
 4. MAXIMUM RATED SHORT CIRCUIT CURRENT (ICW) IS 50KA.
 5. 3x400/230V TN-S (PROVIDED BY OTHERS), FOR OTHER EARTHING PRINCIPLES, PLEASE CONTACT APC BY SCHNEIDER ELECTRIC. RECOMMENDED UPSTREAM PROTECTION IS A MINIMUM RATING TO SUPPORT MAXIMUM CURRENT, WITHOUT SELECTIVITY. SEE SHEET-3 FOR INFRASTRUCTURE PLANNING GUIDE.
 6. FOR TN-S SYSTEMS, PLEASE PROVIDE A SUITABLE EARTH ELECTRODE ACCORDING TO IEC/EN60364-5-55, 551.4.2 TO MAINTAIN THE UPS INVERTER REFERENCE, MUST BE CONNECTED TO THE GROUNDING ELECTRODE TERMINAL-E.
 7. ALL AC POWER CABLES IS L1, L2, L3, N, PE.
 8. SINGLE MAINS IS FACTORY DEFAULT CONFIGURATION. THE I/O FRAME TO MBWD FRAME BUS BAR LINKS MUST BE REMOVED FOR SINGLE MAINS INSTALLATION. FOR DUAL MAINS INSTALLATION CONTACT APC BY SCHNEIDER ELECTRIC FOR RELATED SUBMITTAL DRAWINGS.
 9. DC CABLES SHALL BE 600V RATED, 3-WIRE 4PE. SEE SHEET 3 FOR ADDITIONAL DATA.
 10. CABLE LUGS ARE NOT PROVIDED.
 11. MAXIMUM QUANTITY OF DISTRIBUTION BREAKERS (T5 OPTION ONLY)
 - 4 - IF THE NEUTRAL BAR KIT IS INSTALLED.
 - 8 - IF THE NEUTRAL BAR KIT IS NOT INSTALLED.
 12. THIS DRAWING SHOWS MINIMUM NUMBER OF XR BATTERY FRAMES. MAXIMUM (8) XR BATTERY FRAMES CAN BE BAYED TO UPS. BAYING KIT IS SUPPLIED WITH THIS SOLUTION. XR BATTERY FRAME HAS MOTORIZED BREAKER.

Schneider Electric

TITLE: SYMMETRA PX
 Input: 400/230V AC, 3PH, SINGLE MAINS
 Output: 400/230V AC AND 400V AC, 3PH, 500kW
 TOP FEED WITH EXTERNAL BATTERIES
 SYSTEM ONE LINE DIAGRAM

PROJECT: SUBMITTAL DRAWINGS SHEET 2 OF 3 APPROVED: CLARSEN/FJOSGA/SIMWAG

W/DWG NO: SY500K500TH1C1-SD REV. 1

DATE	DESCRIPTION	BY	CHKD
13-SEP-10	ANGLE	BAJAMURUGAN	
13-SEP-10	PUNCTION	SANDERSEN	
13-SEP-10	N/A		

THIS DRAWING AND SPECIFICATIONS HEREIN ARE THE PROPERTY OF SCHNEIDER ELECTRIC AND SHALL NOT BE COPIED, REPRODUCED OR USED IN WHOLE OR IN PART AS THE BASIS FOR THE MANUFACTURE OR SALE OF ITEMS WITHOUT WRITTEN PERMISSION FROM SCHNEIDER ELECTRIC. THIS DRAWING IS BASED UPON LATEST AVAILABLE INFORMATION AND IS SUBJECT TO CHANGE WITHOUT NOTICE.

Symmetra PX 500 kW 400 V Single Utility/Mains with Maintenance Bypass and Remote Batteries – Bottom Feed

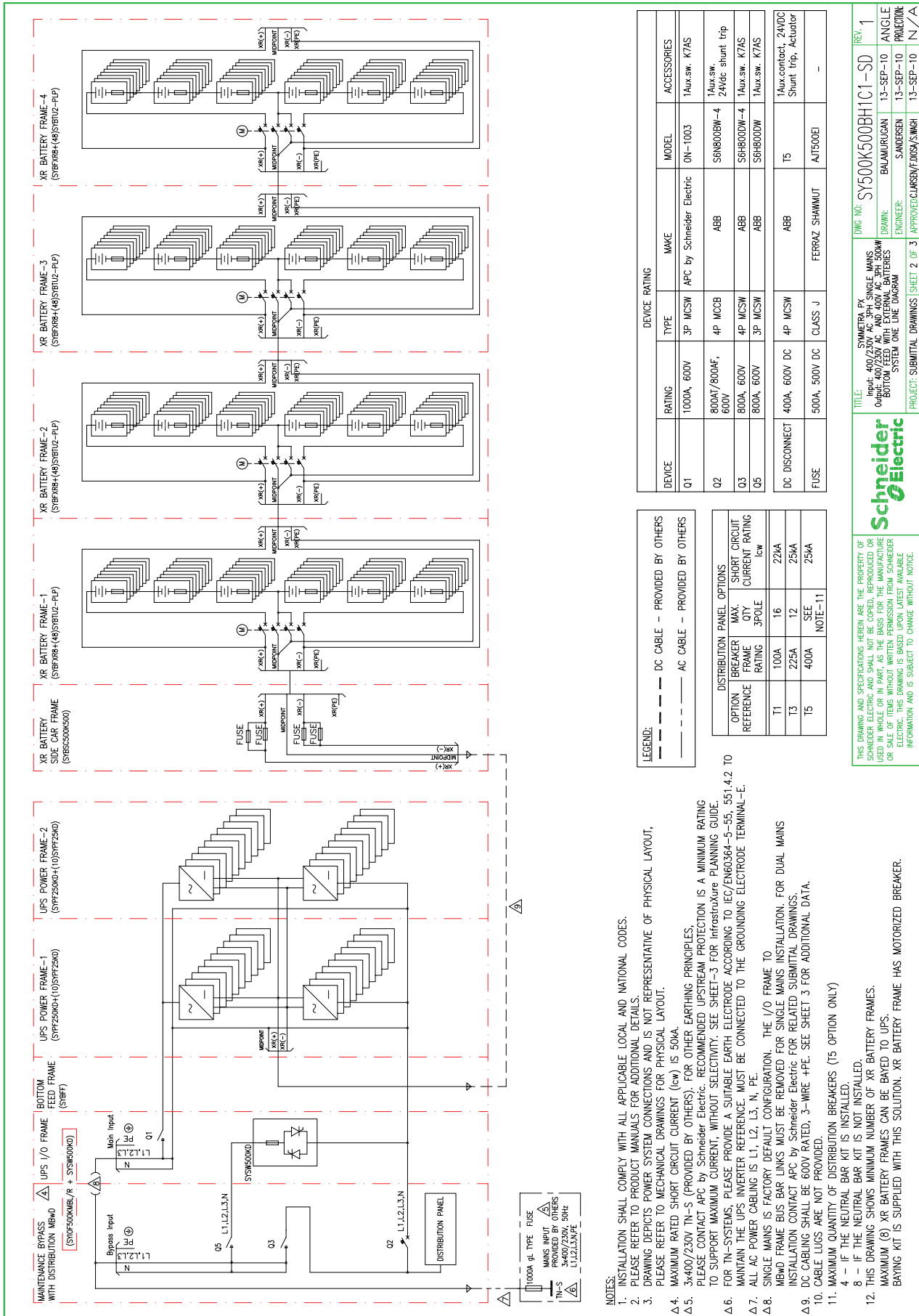

DEVI	RATING	TYPE	MAKE	MODEL	ACCESSORIES
Q1	1000A, 600V	3P MCSW	APC by Schneider Electric	0N-1003	1Aux.sw. K7AS
Q2	800A/800AF, 600V	4P MCCB	ABB	S8N800BN-4	1Aux.sw. 24Vdc shunt trip
Q3	800A, 600V	4P MCSW	ABB	S8H800DN-4	1Aux.sw. K7AS
Q5	800A, 600V	3P MCSW	ABB	S8H800DW	1Aux.sw. K7AS
DC DISCONNECT	400A, 600V DC	4P MCSW	ABB	T5	1Aux.contact, 24VDC Shunt trip, Actuator
FUSE	500A, 500V DC	CLASS J	FERRAZ SHAWMUT	AJ1500E1	-

LEGEND: --- DC CABLE -- PROVIDED BY OTHERS
 --- AC CABLE -- PROVIDED BY OTHERS

DISTRIBUTION PANEL OPTION REFERENCE	BREAKER FRAME RATING	MAX. QTY	SHORT CIRCUIT CURRENT RATING Icw
T1	100A	16	22KA
T3	225A	12	25KA
T5	400A	SEE NOTE-11	25KA

- NOTES:
- INSTALLATION SHALL COMPLY WITH ALL APPLICABLE LOCAL AND NATIONAL CODES.
 - PLEASE REFER TO PRODUCT MANUALS FOR ADDITIONAL DETAILS.
 - DRAWING DEPICTS POWER SYSTEM CONNECTIONS AND IS NOT REPRESENTATIVE OF PHYSICAL LAYOUT, PLEASE REFER TO MECHANICAL DRAWINGS FOR PHYSICAL LAYOUT.
 - MAXIMUM RATED SHORT CIRCUIT CURRENT (Icw) IS 50KA.
 - 3x400/230V TN-S (PROVIDED BY OTHERS), FOR OTHER EARTHING PRINCIPLES, PLEASE CONTACT APC BY SCHNEIDER ELECTRIC. RECOMMENDED UPSTREAM PROTECTION IS A MINIMUM RATING TO SUPPORT MAXIMUM CURRENT, WITHOUT SELECTIVITY. SEE SHEET-3 FOR INFRASTRUCTURE PLANNING GUIDE.
 - FOR TN-S SYSTEMS, PLEASE PROVIDE A SUITABLE EARTH ELECTRODE ACCORDING TO IEC/EN60364-5-55, 551.4.2 TO MAINTAIN THE UPS INVERTER REFERENCE, MUST BE CONNECTED TO THE GROUNDING ELECTRODE TERMINAL-E.
 - ALL AC POWER CABLING IS L1, L2, L3, N, PE.
 - SINGLE MAINS IS FACTORY DEFAULT CONFIGURATION. THE I/O FRAME TO MBWD FRAME BUS BAR LINKS MUST BE REMOVED FOR SINGLE MAINS INSTALLATION. FOR DUAL MAINS INSTALLATION CONTACT APC BY SCHNEIDER ELECTRIC FOR RELATED SUBMITTAL DRAWINGS.
 - DC CABLING SHALL BE 600V RATED, 3-WIRE 4PE. SEE SHEET 3 FOR ADDITIONAL DATA.
 - CABLE LUGS ARE NOT PROVIDED.
 - MAXIMUM QUANTITY OF DISTRIBUTION BREAKERS (T5 OPTION ONLY)
 4 -- IF THE NEUTRAL BAR KIT IS INSTALLED.
 8 -- IF THE NEUTRAL BAR KIT IS NOT INSTALLED.
 - THIS DRAWING SHOWS MINIMUM NUMBER OF XR BATTERY FRAMES. MAXIMUM (8) XR BATTERY FRAMES CAN BE BAYED TO UPS. BAYING KIT IS SUPPLIED WITH THIS SOLUTION. XR BATTERY FRAME HAS MOTORIZED BREAKER.

TITLE: SYMMETRA PX 500kW 400V AC 3PH 4W 50Hz SINGLE MAINS ON 400/230V TN-S (PROVIDED BY OTHERS) WITH MAINTENANCE BYPASS AND BOTTOM FEED WITH EXTERNAL BATTERIES SYSTEM ONE LINE DIAGRAM
 DWG NO: SY500K500BH1C1-SD
 DRAWN: BALAMURUGAN
 ENGINEER: SAMDENSEN
 APPROVED: CLARENCE FLORES/SINGH
 PROJECT: SUBMITTAL DRAWINGS | SHEET 2 OF 3
 REV: 1
 ANGLE PROJECTION: 13-SEP-10 N/A
 13-SEP-10 N/A

Symmetra PX 500 kW 400 V Dual Mains with Maintenance Bypass and Line-And-Match Batteries – Top Feed

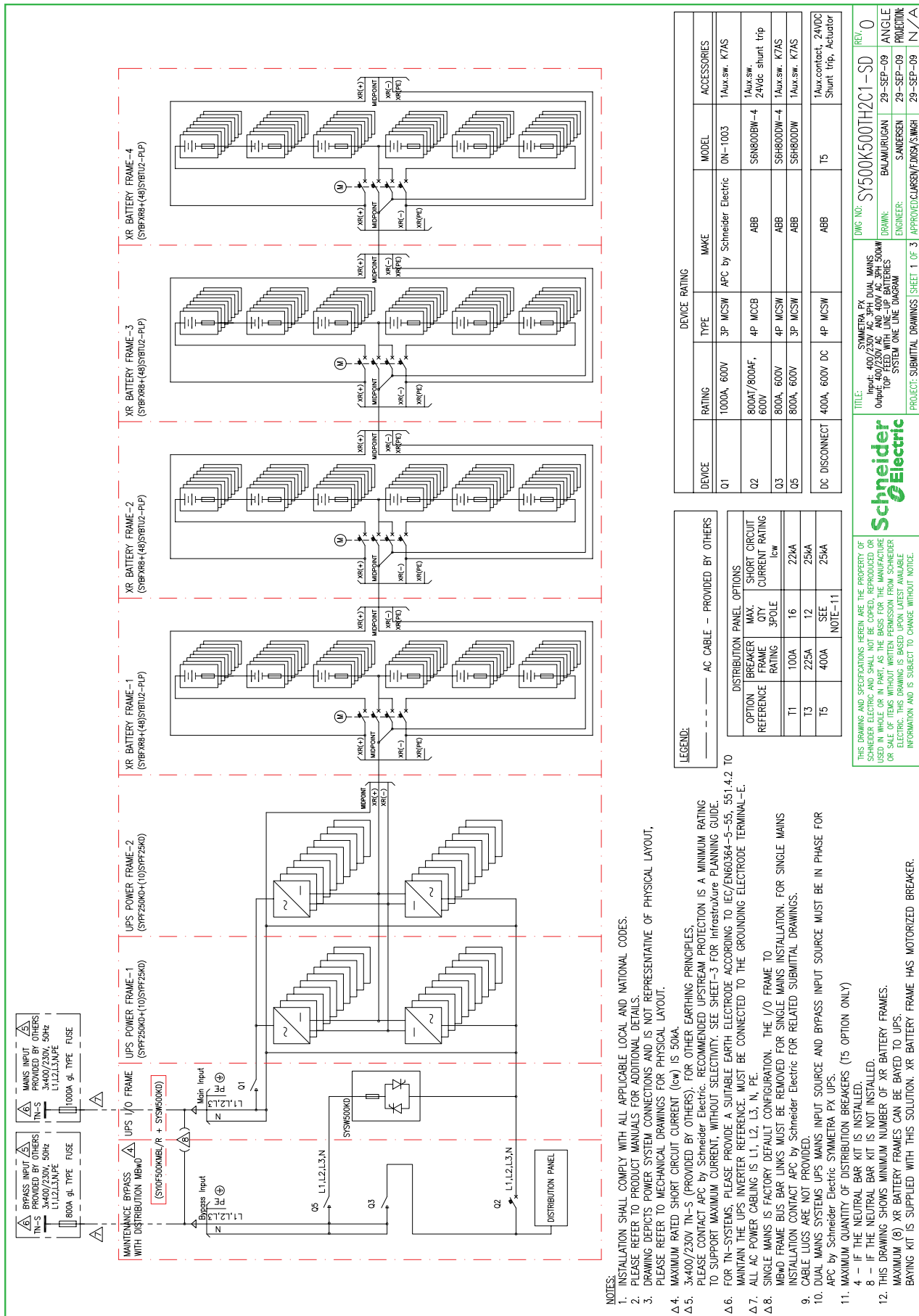

- NOTES:**
1. INSTALLATION SHALL COMPLY WITH ALL APPLICABLE LOCAL AND NATIONAL CODES.
 2. PLEASE REFER TO PRODUCT MANUALS FOR ADDITIONAL DETAILS.
 3. DRAWING DEPICTS POWER SYSTEM CONNECTIONS AND IS NOT REPRESENTATIVE OF PHYSICAL LAYOUT. PLEASE REFER TO MECHANICAL DRAWINGS FOR PHYSICAL LAYOUT.
 - 4.4. MAXIMUM RATED SHORT CIRCUIT CURRENT (I_{sc}) IS 50kA.
 - 4.5. 3x400/230V TN-S (PROVIDED BY OTHERS). FOR OTHER EARTHING PRINCIPLES, PLEASE CONTACT APC by Schneider Electric. RECOMMENDED UPSTREAM PROTECTION IS A MINIMUM RATING TO SUPPORT MAXIMUM CURRENT, WITHOUT SELECTIVITY. SEE SHEET-3 FOR Infrastructure PLANNING GUIDE.
 - 4.6. FOR TN-S SYSTEMS, PLEASE PROVIDE A SUITABLE EARTH ELECTRODE ACCORDING TO IEC/EN60364-5-55, 551.4.2 TO MAINTAIN THE UPS INVERTER REFERENCE. MUST BE CONNECTED TO THE GROUNDING ELECTRODE TERMINAL-E.
 - 4.7. ALL AC POWER CABLING IS L1, L2, L3, N, PE.
 - 4.8. SINGLE MAINS IS FACTORY DEFAULT CONFIGURATION. THE I/O FRAME TO MEND FRAME BUS BAR LINKS MUST BE REMOVED FOR SINGLE MAINS INSTALLATION. FOR SINGLE MAINS INSTALLATION CONTACT APC by Schneider Electric FOR RELATED SUBMITTAL DRAWINGS.
 9. CABLE LOGS ARE NOT PROVIDED.
 10. DUAL MAINS SYSTEMS UPS MAINS INPUT SOURCE AND BYPASS INPUT SOURCE MUST BE IN PHASE FOR APC by Schneider Electric SYMMETRA PX UPS.
 11. MAXIMUM QUANTITY OF DISTRIBUTION BREAKERS (T5 OPTION ONLY)
 - 4 – IF THE NEUTRAL BAR KIT IS INSTALLED.
 - 8 – IF THE NEUTRAL BAR KIT IS NOT INSTALLED.
 12. THIS DRAWING SHOWS MINIMUM NUMBER OF XR BATTERY FRAMES. MAXIMUM (6) XR BATTERY FRAMES CAN BE BATED TO UPS. BAYING KIT IS SUPPLIED WITH THIS SOLUTION. XR BATTERY FRAME HAS MOTORIZED BREAKER.

LEGEND: ——— AC CABLE — PROVIDED BY OTHERS

DISTRIBUTION BREAKER REFERENCE	SHORT CIRCUIT CURRENT RATING		
	MAX. QTY	3-POLE	I _{sc}
T1	100A	16	22kA
T3	225A	12	25kA
T5	400A	SEE NOTE-11	25kA

DEVICE	RATING	TYPE	MAKE	MODEL	ACCESSORIES
Q1	1000A, 600V	3P MCSW	APC by Schneider Electric	0N-1003	1Aux.sw. K7AS
Q2	800A/800AF, 600V	4P MCCB	ABB	S6N800BW-4	1Aux.sw. 24Vdc shunt trip
Q3	800A, 600V	4P MCSW	ABB	S6H800DW-4	1Aux.sw. K7AS
Q5	800A, 600V	3P MCSW	ABB	S6H800DW	1Aux.sw. K7AS
DC DISCONNECT	400A, 600V DC	4P MCSW	ABB	T5	1Aux.contact, 24VDC Shunt trip, Actuator

Schneider Electric

PROJECT: SUBMITTAL DRAWINGS SHEET 1 OF 3 APPROVED: CLAUSEN/F.DOSJA/S.MWH

DATE: 29-SEP-09

REVISION: 0

DRIVER: BALAMURUGAN

ENGINEER: SANDERSEN

PROJECT: SYMMETRA PX 500kW AC 3PH DUAL MAINS TOP FEED WITH LINE-UP BATTERIES SYSTEM ONE LINE DIAGRAM

UWG NO: SY500K500TH2C1-SD

ANGLE: N/A

PROTECTION: N/A

THIS DRAWING AND SPECIFICATIONS HEREIN ARE THE PROPERTY OF SCHNEIDER ELECTRIC AND SHALL NOT BE COPIED, REPRODUCED OR USED IN WHOLE OR IN PART AS THE BASIS FOR THE MANUFACTURE OR SALE OF ITEMS WITHOUT WRITTEN PERMISSION FROM SCHNEIDER ELECTRIC. THIS DRAWING IS BASED UPON LATEST AVAILABLE INFORMATION AND IS SUBJECT TO CHANGE WITHOUT NOTICE.

Symmetra PX 500 kW 400 V Dual Utility/Mains with Maintenance Bypass and Remote Batteries – Bottom Feed

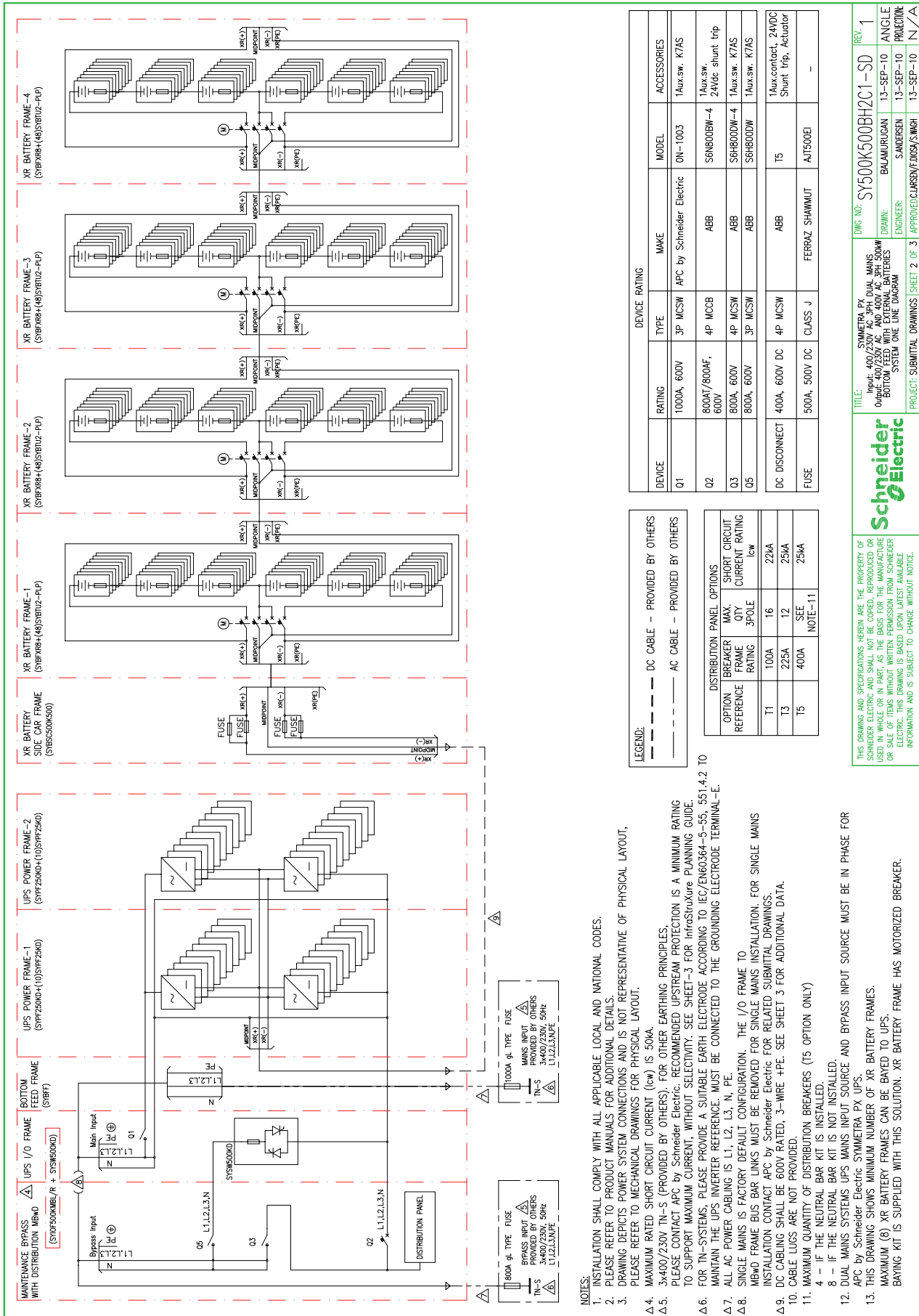

DEVICE	RATING	TYPE	MAKE	MODEL	ACCESSORIES
Q1	1000A, 600V	3P MCSW	APC by Schneider Electric	ON-1003	1Aux.sw. K7AS
Q2	800AT/800AF, 600V	4P MCCB	ABB	SBN800BW-4	1Aux.sw. 24Vdc shunt trip
Q3	800A, 600V	4P MCSW	ABB	SBR800DW-4	1Aux.sw. K7AS
Q5	800A, 600V	3P MCSW	ABB	SBR800DW	1Aux.sw. K7AS
DC DISCONNECT	400A, 600V DC	4P MCSW	ABB	T5	1Aux contact, 24VDC Shunt trip, Actuator
FUSE	500A, 500V DC	CLASS J	FERRAZ SHAWMUT	AJT500EI	-

LEGEND:

--- DC CABLE -- PROVIDED BY OTHERS
 - - - AC CABLE -- PROVIDED BY OTHERS

OPTION REFERENCE	BREAKER RATING	MAX. QTY 3-POLE	SHORT CIRCUIT CURRENT RATING Icw
T1	100A	16	22kA
T3	225A	12	25kA
T5	400A	SEE NOTE-11	25kA

UNG NO: SY500K500BH2C1-SD
 BALAMURUGAN
 SANDERSEN
 APPROVED: CLARENCE PERKINS/SWGH

Schneider Electric

THIS DRAWING AND SPECIFICATIONS HEREIN ARE THE PROPERTY OF SCHNEIDER ELECTRIC AND SHALL NOT BE COPIED, REPRODUCED OR USED IN WHOLE OR IN PART AS THE BASIS FOR THE MANUFACTURE OR SALE OF ANY EQUIPMENT WITHOUT THE WRITTEN CONSENT OF SCHNEIDER ELECTRIC. THIS DRAWING IS BASED UPON LATEST AVAILABLE INFORMATION AND IS SUBJECT TO CHANGE WITHOUT NOTICE.

PROJECT: SUBMITTAL DRAWINGS | SHEET 2 OF 3 | APPROVED: CLARENCE PERKINS/SWGH

- NOTES:
- INSTALLATION SHALL COMPLY WITH ALL APPLICABLE LOCAL AND NATIONAL CODES.
 - PLEASE REFER TO PRODUCT MANUALS FOR ADDITIONAL DETAILS.
 - DRAWING DEPICTS POWER SYSTEM CONNECTIONS AND IS NOT REPRESENTATIVE OF PHYSICAL LAYOUT, PLEASE REFER TO MECHANICAL DRAWINGS FOR PHYSICAL LAYOUT.
 - MAXIMUM RATED SHORT CIRCUIT CURRENT (Icw) IS 50kA.
 - 3x400/230V TN-S (PROVIDED BY OTHERS), FOR OTHER EARTHING PRINCIPLES, PLEASE CONTACT APC BY SCHNEIDER ELECTRIC. RECOMMENDED UPSTREAM PROTECTION IS A MINIMUM RATING TO SUPPORT MAXIMUM CURRENT, WITHOUT SELECTIVITY. SEE SHEET-3 FOR INFRASTRUCTURE PLANNING GUIDE.
 - FOR TN-S SYSTEMS, PLEASE PROVIDE A SUITABLE EARTH ELECTRODE ACCORDING TO IEC/EN60364-5-55, 551.4.2 TO MAINTAIN THE UPS INVERTER REFERENCE MUST BE CONNECTED TO THE GROUNDING ELECTRODE TERMINAL-E.
 - ALL AC POWER CABLING IS L1, L2, L3, N, PE.
 - SINGLE MAINS IS FACTORY DEFAULT CONFIGURATION. THE I/O FRAME TO MBRD FRAME BUS BAR LINKS MUST BE REMOVED FOR SINGLE MAINS INSTALLATION. FOR SINGLE MAINS INSTALLATION CONTACT APC BY SCHNEIDER ELECTRIC FOR RELATED SUBMITTAL DRAWINGS.
 - DC CABLING SHALL BE 600V RATED, 3-WIRE 4PE. SEE SHEET 3 FOR ADDITIONAL DATA.
 - CABLE LUGS ARE NOT PROVIDED.
 - MAXIMUM QUANTITY OF DISTRIBUTION BREAKERS (T5 OPTION ONLY)
 4 - IF THE NEUTRAL BAR KIT IS INSTALLED.
 8 - IF THE NEUTRAL BAR KIT IS NOT INSTALLED.
 - DUAL MAINS SYSTEMS UPS MAINS INPUT SOURCE AND BYPASS INPUT SOURCE MUST BE IN PHASE FOR APC BY Schneider Electric. SYMMETRA PX UPS.
 - THIS DRAWING SHOWS MINIMUM NUMBER OF XR BATTERY FRAMES. MAXIMUM (8) XR BATTERY FRAMES CAN BE BAYED TO UPS. BAYING KIT IS SUPPLIED WITH THIS SOLUTION. XR BATTERY FRAME HAS MOTORIZED BREAKER.

Symmetra PX 500 kW 400 V Dual Utility/Mains with Maintenance Bypass and Line-Up-And-Match Batteries – Bottom Feed

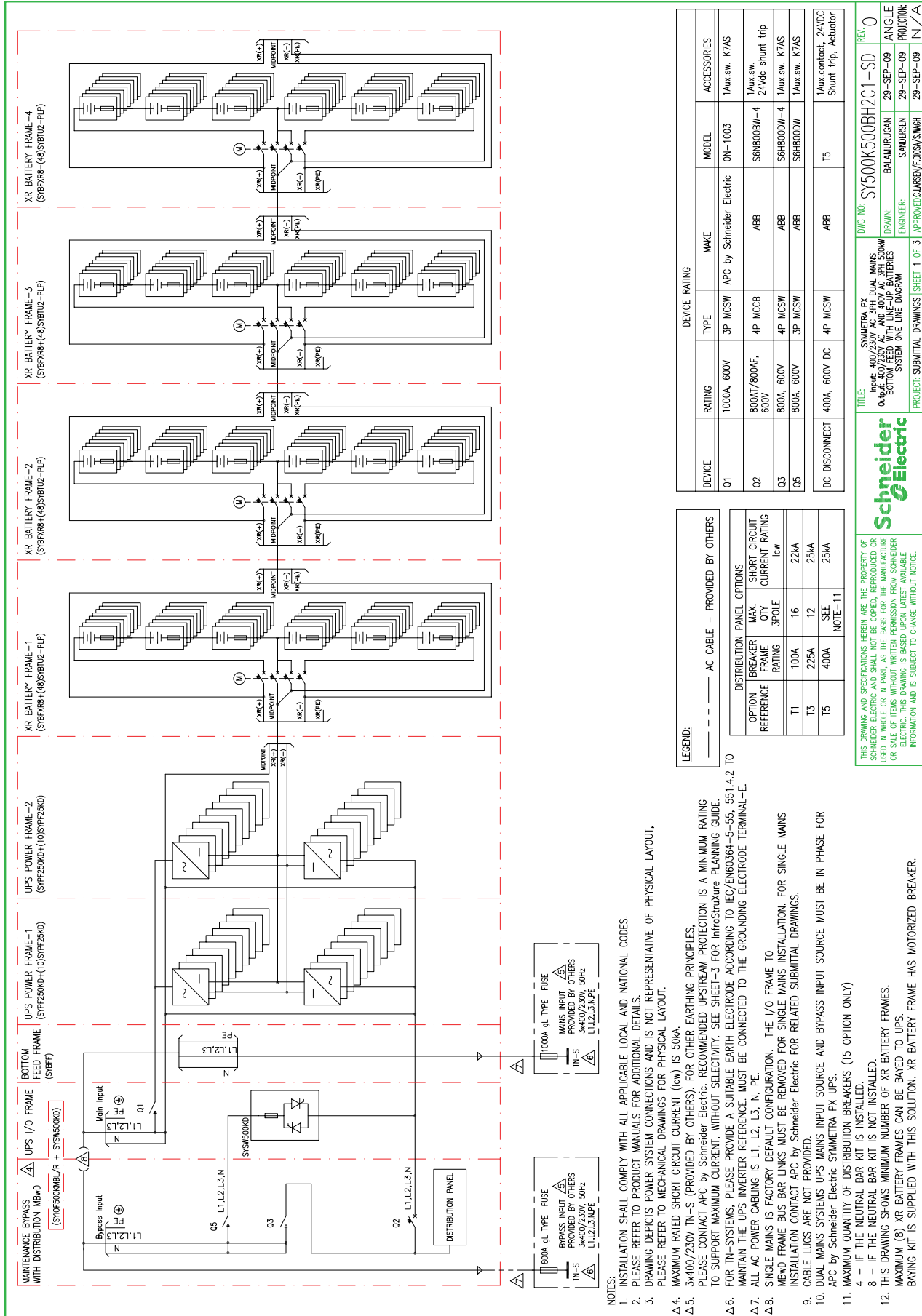

SYMMETRA PX
 Input: 400/230V AC, 3PH DUAL MAINS
 Output: 400/230V AC AND 400V AC 3PH 500kW
 BOTTOM FEED WITH LINE-UP BATTERIES
 SYSTEM ONE LINE DIAGRAM

PROJECT: SUBMITTAL DRAWINGS SHEET 1 OF 3 APPROVED: CLARENCE/FIDISA/SWGH

DRG. NO. SY500K500BH2C1-S0 REV: 0

DRAWN: BALAMURUGAN 29-SEP-09
ENGINEER: S. ANDERSEN 29-SEP-09
FUNCTION: PROJECTING 29-SEP-09

Schneider Electric

DC DISCONNECT
 T5

Symmetra PX 500 kW 400 V Dual Utility/Mains with Maintenance Bypass and Remote Batteries – Top Feed

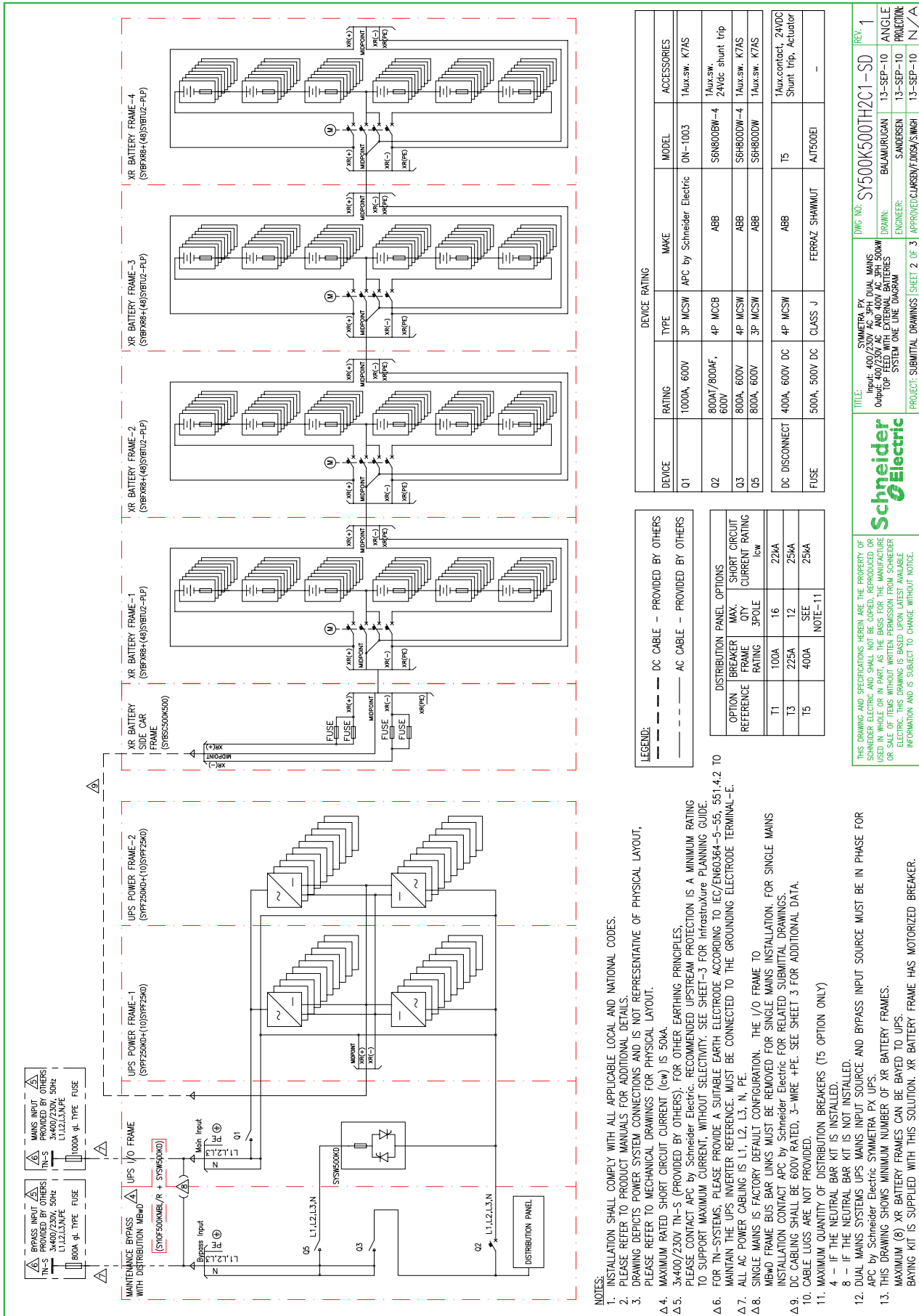

Rev. 1

SYMMETRA PX 500kW 400V AC DUAL MAINS WITH MAINTENANCE BYPASS AND REMOTE BATTERIES SYSTEM ONE LINE DIAGRAM

UNG NO: SY500K500TH2C1-SD

DRAWN: BALAJURGAN 13-SEP-10
 ENGINEER: SANDERSEN 13-SEP-10
 APPROVED: CLARENCE FLORES/SINGH 13-SEP-10

Schneider Electric

THIS DRAWING AND SPECIFICATIONS HEREIN ARE THE PROPERTY OF SCHNEIDER ELECTRIC AND SHALL NOT BE COPIED, REPRODUCED OR USED IN WHOLE OR IN PART AS THE BASIS FOR THE MANUFACTURE OR SALE OF ANY EQUIPMENT WITHOUT THE WRITTEN CONSENT OF SCHNEIDER ELECTRIC. THIS DRAWING IS BASED UPON LATEST AVAILABLE INFORMATION AND IS SUBJECT TO CHANGE WITHOUT NOTICE.

Symmetra PX 500 kW 480 V Single Mains with Maintenance Bypass (3 Wire Output) and Line-Up-And-Match Batteries – Top Feed

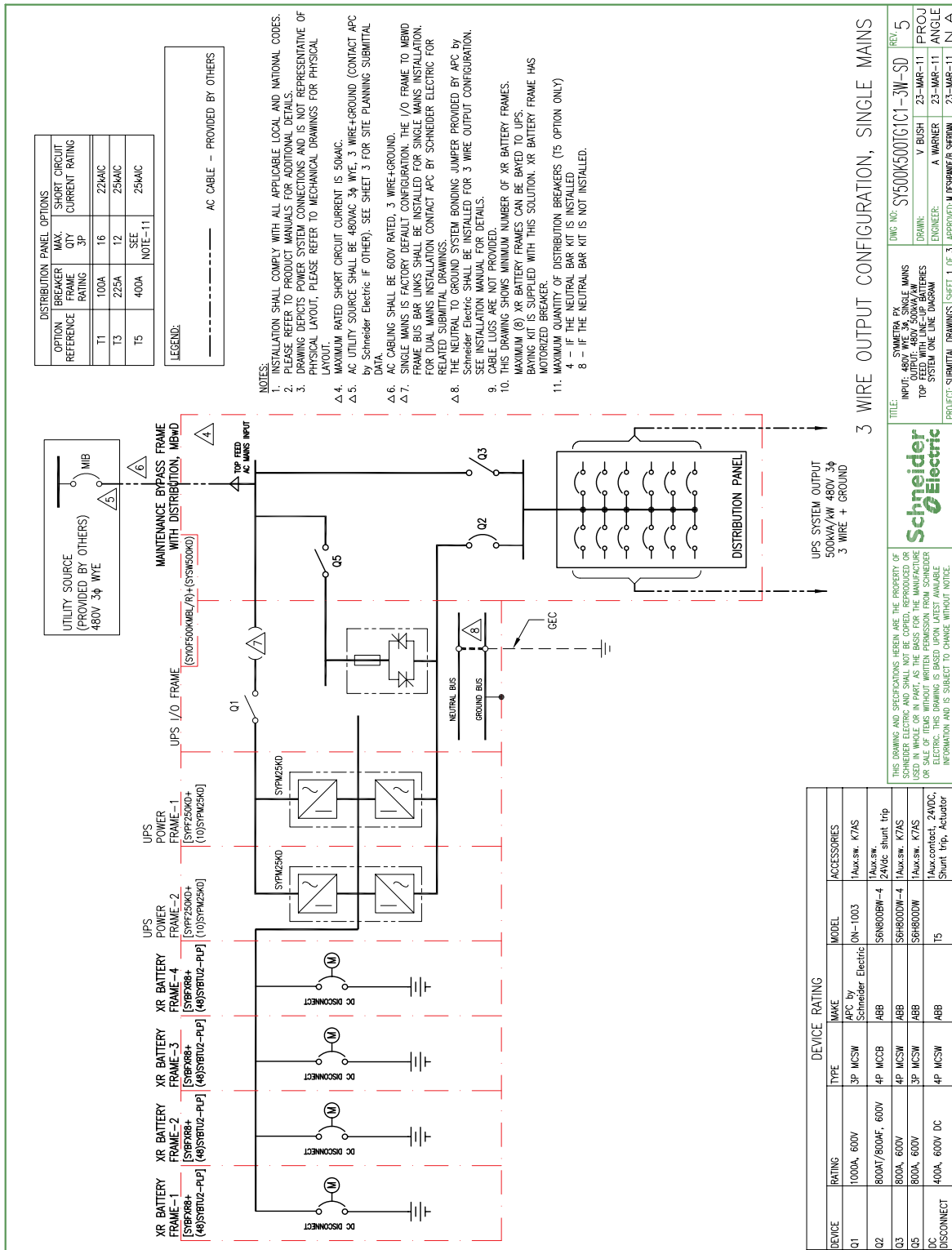

Symmetra PX 500 kW 480 V Dual Mains with Maintenance Bypass (3 Wire Output) and Line-Up-And-Match Batteries – Top Feed

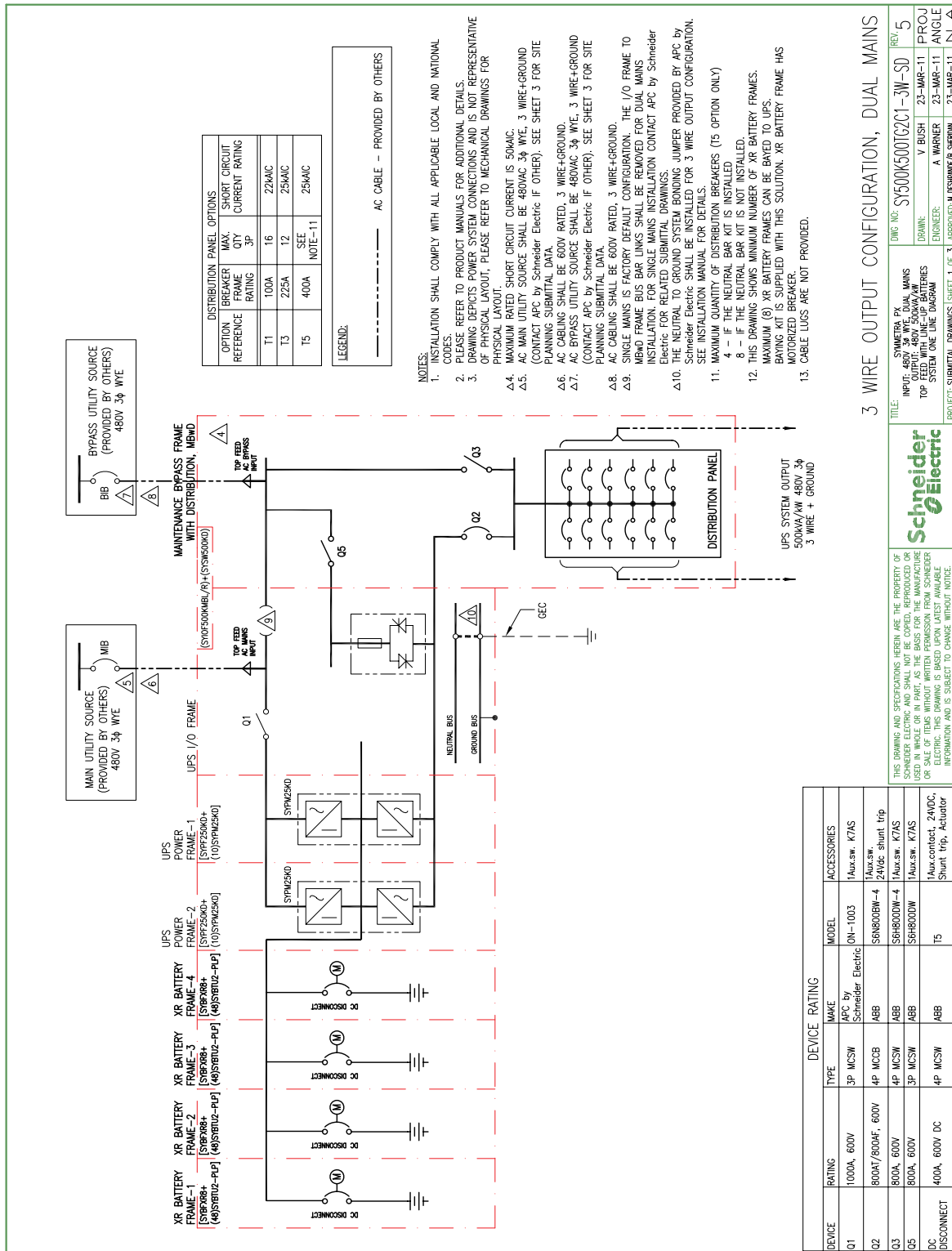

DEVICE	RATING		DEVICE RATING		ACCESSORIES
	TYPE	MAKE	MODEL	MAKE	
O1	3P MCSW	APC by Schneider Electric	ON-1003	Aux.sw. K7AS	
O2	4P MCCB	ABB	SEW600BW-4	Aux.sw. K7AS 24Vdc shunt trip	
O3	4P MCSW	ABB	SEW600BW-4	Aux.sw. K7AS	
O5	3P MCSW	ABB	SEW600BW	Aux.sw. K7AS	
DC DISCONNECT	4P MCSW DC	ABB	TS	Aux.contact, 24VDC, Shunt trip, Actuator	

3 WIRE OUTPUT CONFIGURATION, DUAL MAINS

TITLE: SYMMETRA PX BY 500KVA/480V 3 WIRE DUAL MAINS
 INPUT: 480V 3φ WYE
 OUTPUT: 480V 500kVA/480V 3 WIRE + GROUND
 TOP SYSTEM ONE LINE DIAGRAM

REV. 5
 23-MAR-11
 V BUSH
 A WARNER
 23-MAR-11
 N.A

PROJECT: SUBMITTAL DRAWINGS SHEET 1 OF 3 APPROVED: M DESPAIN/E/S/SDM



THIS DRAWING AND SPECIFICATIONS HEREIN ARE THE PROPERTY OF SCHNEIDER ELECTRIC AND SHALL NOT BE COPIED, REPRODUCED OR USED IN WHOLE OR IN PART AS THE BASIS FOR THE MANUFACTURE OR SALE OF ITEMS WITHOUT WRITTEN PERMISSION FROM SCHNEIDER ELECTRIC. THIS DRAWING IS BASED UPON LATEST AVAILABLE INFORMATION AND IS SUBJECT TO CHANGE WITHOUT NOTICE.

Symmetra PX 500 kW 480 V Single Mains with Maintenance Bypass (3 Wire Output) and Line-Up-And-Match Batteries – Bottom Feed

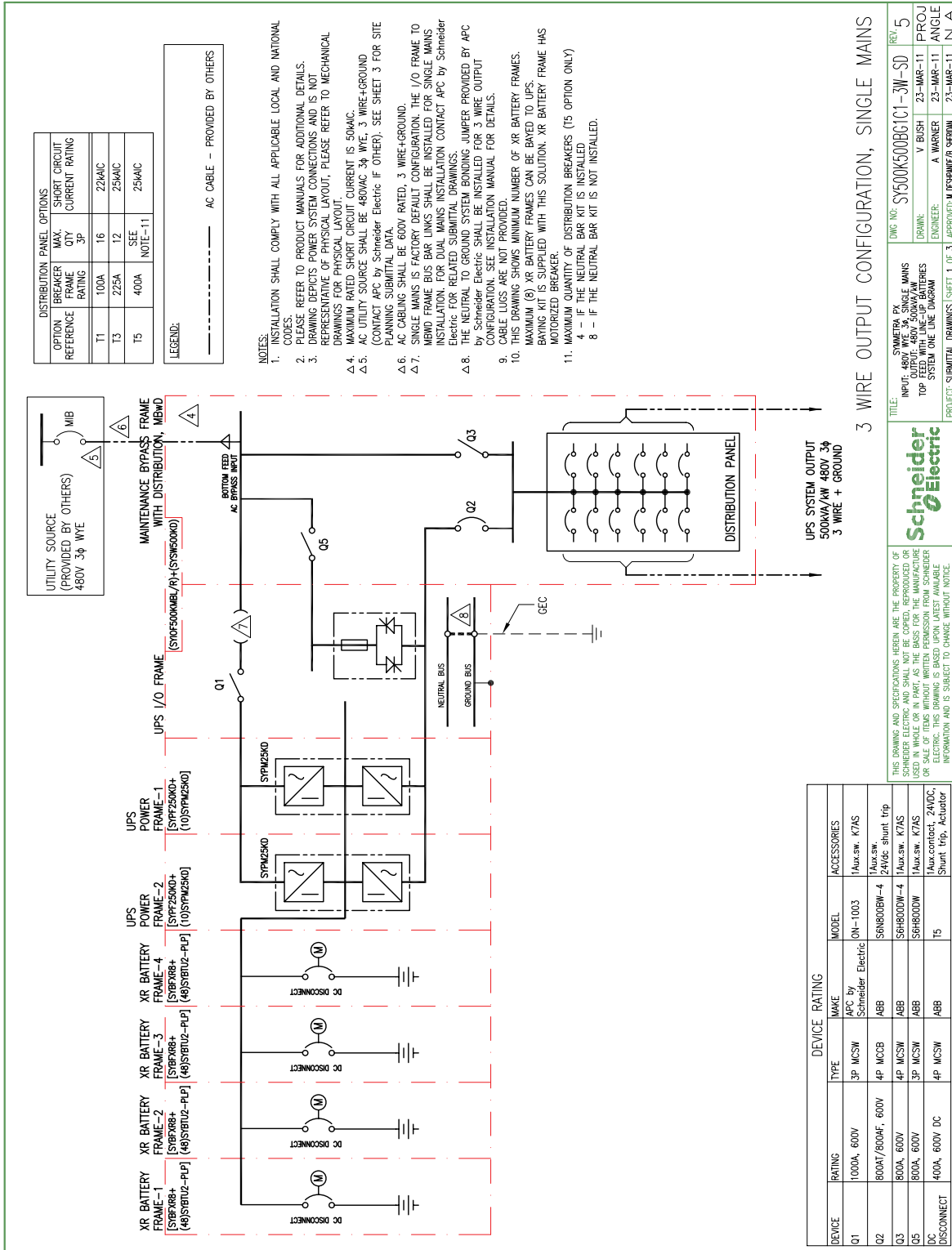

DISTRIBUTION PANEL OPTIONS		
OPTION	BREAKER FRAME RATING	SHORT CIRCUIT CURRENT RATING
T1	100A	16 22kAIC
T3	225A	12 25kAIC
T5	400A	SEE NOTE-11 25kAIC

LEGEND:
 --- AC CABLE - PROVIDED BY OTHERS

- NOTES:
1. INSTALLATION SHALL COMPLY WITH ALL APPLICABLE LOCAL AND NATIONAL CODES.
 2. PLEASE REFER TO PRODUCT MANUALS FOR ADDITIONAL DETAILS.
 3. DRAWING DEPICTS POWER SYSTEM CONNECTIONS AND IS NOT REPRESENTATIVE OF PHYSICAL LAYOUT. PLEASE REFER TO MECHANICAL DRAWINGS FOR PHYSICAL LAYOUT.
 4. MAXIMUM RATED SHORT CIRCUIT CURRENT IS 50kAIC.
 5. AC UTILITY SOURCE SHALL BE 480VAC 3Φ WYE, 3 WIRE+GROUND (CONTACT APC BY Schneider Electric IF OTHER). SEE SHEET 3 FOR SITE PLANNING SUBMITTAL DATA.
 6. AC CABLING SHALL BE 600V RATED, 3 WIRE+GROUND.
 7. SINGLE MAINS IS FACTORY DEFAULT CONFIGURATION. THE I/O FRAME TO MEND FRAME BUS BAR LINKS SHALL BE INSTALLED FOR SINGLE MAINS INSTALLATION. FOR DUAL MAINS INSTALLATION CONTACT APC BY Schneider Electric FOR RELATED SUBMITTAL DRAWINGS.
 8. THE NEUTRAL TO GROUND SYSTEM BONDING JUMPER PROVIDED BY APC BY Schneider Electric SHALL BE INSTALLED FOR 3 WIRE OUTPUT CONFIGURATION. SEE INSTALLATION MANUAL FOR DETAILS.
 9. CABLE LUGS ARE NOT PROVIDED.
 10. THIS DRAWING SHOWS MINIMUM NUMBER OF XR BATTERY FRAMES. MAXIMUM (8) XR BATTERY FRAMES CAN BE BAYED TO UPS. BAYING KIT IS SUPPLIED WITH THIS SOLUTION. XR BATTERY FRAME HAS MOTORIZED BREAKER.
 11. MAXIMUM QUANTITY OF DISTRIBUTION BREAKERS (15 OPTION ONLY)
 - 4 - IF THE NEUTRAL BAR KIT IS INSTALLED
 - 8 - IF THE NEUTRAL BAR KIT IS NOT INSTALLED.

DEVICE RATING			
DEVICE	RATING	MAKE	MODEL
Q1	1000A, 600V	APC by Schneider Electric	ON-1003
Q2	800A/800AF, 600V	ABB	5S8B00DN-4
Q3	800A, 600V	ABB	5S8B00DN-4
Q5	800A, 600V	ABB	5S8B00DN
DC DISCONNECT	400A, 600V DC	ABB	T5

3 WIRE OUTPUT CONFIGURATION, SINGLE MAINS

TITLE: SYMMETRA PX 500kW/4W 480V 3Φ SINGLE MAINS TOP FEED WITH LINE-UP BATTERIES SYSTEM ONE LINE DIAGRAM
 PROJECT: SUBMITTAL DRAWINGS SHEET 1 OF 3 APPROVED: M LESZCZYNSKI
 DRAWN: V BUSH 23-MAR-11
 ENGINEER: A WARNER 23-MAR-11
 PROJECT: SUBMITTAL DRAWINGS SHEET 1 OF 3 APPROVED: M LESZCZYNSKI 23-MAR-11
 DRAWING NO: SY500K500B61C1-3W-SD
 REV: 5
 PROJ: N.A.
 ANGLE: N.A.

THIS DRAWING AND SPECIFICATIONS HEREIN ARE THE PROPERTY OF SCHNEIDER ELECTRIC AND SHALL NOT BE COPIED, REPRODUCED OR USED IN WHOLE OR IN PART, AS THE BASIS FOR THE MANUFACTURE OR SALE OF ANY ELECTRICAL EQUIPMENT, WITHOUT THE WRITTEN PERMISSION OF SCHNEIDER ELECTRIC. THIS DRAWING IS BASED UPON LATEST AVAILABLE INFORMATION AND IS SUBJECT TO CHANGE WITHOUT NOTICE.

Symmetra PX 500 kW 480 V Dual Mains with Maintenance Bypass (3 Wire Output) and Line-Up-And-Match Batteries – Bottom Feed

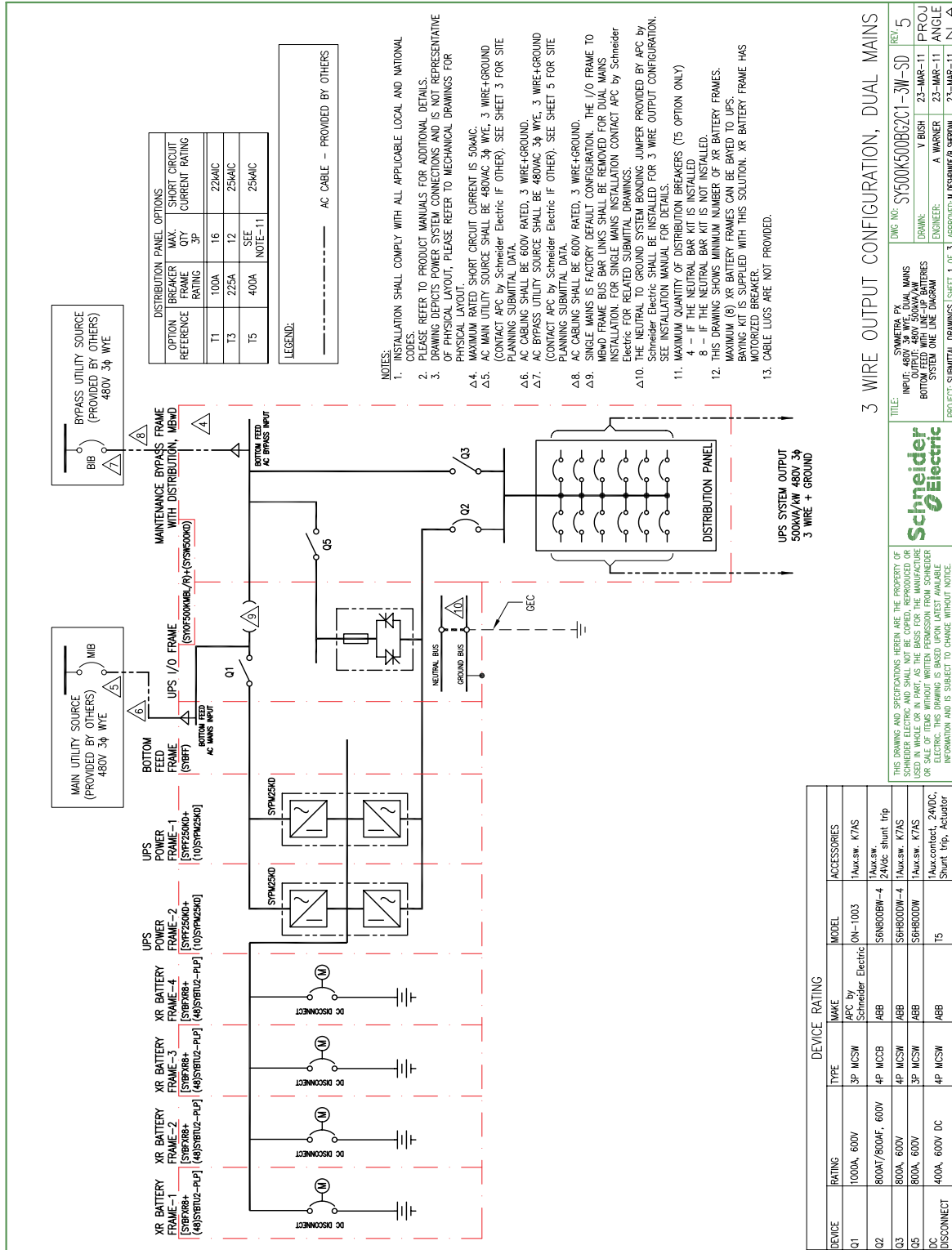

3 WIRE OUTPUT CONFIGURATION, DUAL MAINS

DWG NO: S1500K500B2C1-3W-SD REV: 5
 DRAWN: V BISH 23-MAR-11 PROJ: ANGLE
 ENGINEER: A WARNER 23-MAR-11
 APPROVED: M WESPANEZ 23-MAR-11



THIS DRAWING AND SPECIFICATIONS HEREIN ARE THE PROPERTY OF SCHNEIDER ELECTRIC AND SHALL NOT BE COPIED, REPRODUCED OR USED IN WHOLE OR IN PART, AS THE BASIS FOR THE MANUFACTURE OR SALE OF ITEMS WITHOUT WRITTEN PERMISSION FROM SCHNEIDER ELECTRIC. THIS DRAWING IS BASED UPON LATEST AVAILABLE INFORMATION AND IS SUBJECT TO CHANGE WITHOUT NOTICE.

Symmetra PX 500 kW 480 V Single Mains with Maintenance Bypass (4 Wire Output) and Line-Up-And-Match Batteries – Top Feed

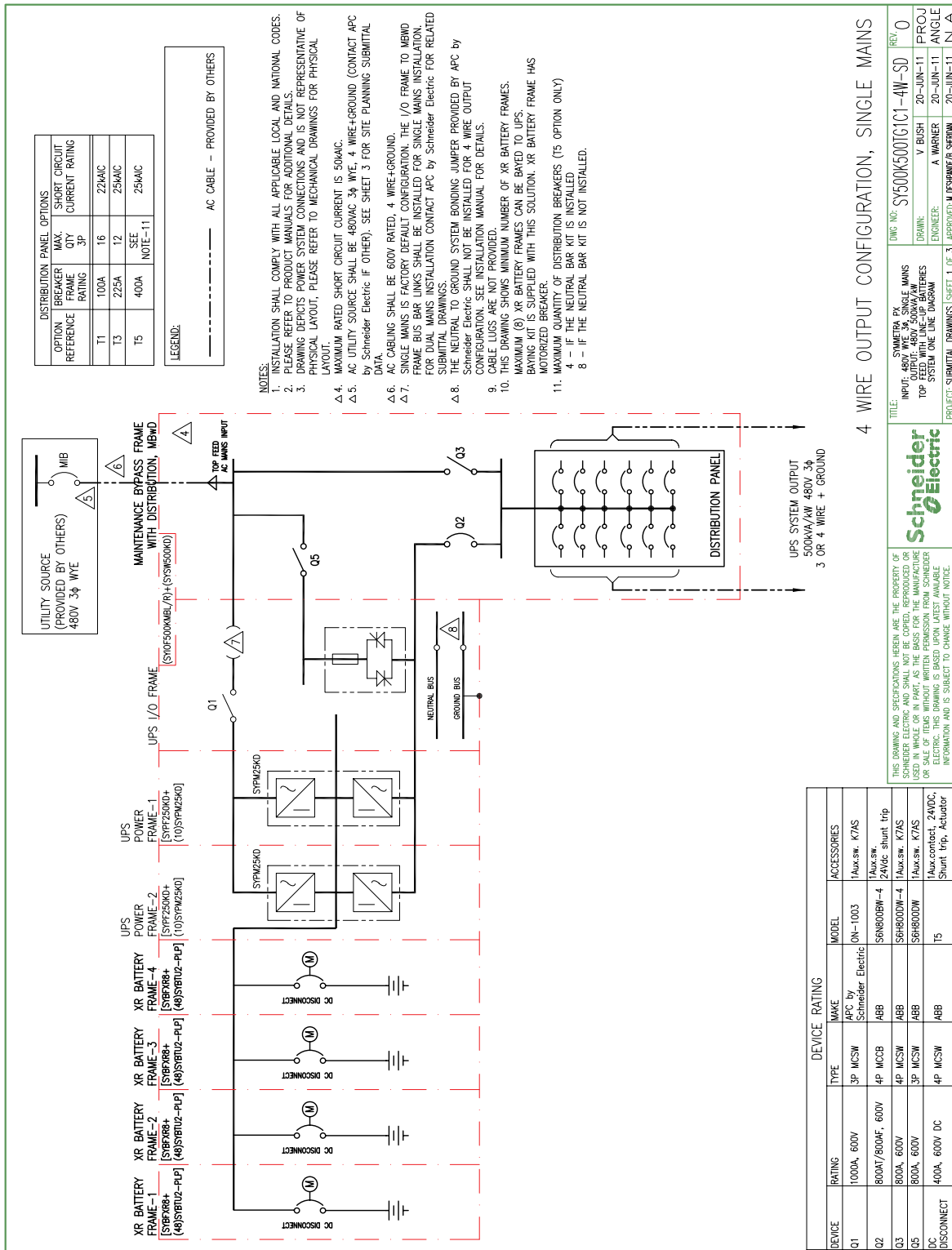

4 WIRE OUTPUT CONFIGURATION, SINGLE MAINS

DMC NO: SY500K500TG1C1-4W-SD REV: 0
 DRAWN: V BUSH 20-JUN-11 PROJ
 ENGINEER: A WARNER 20-JUN-11 ANGLE
 PROJECT: SUBMITTAL DRAWINGS SHEET 1 OF 3 APPROVED: M DESPAIN/E/SERBOW 20-JUN-11 N.A.

Schneider Electric

THIS DRAWING AND SPECIFICATIONS HEREIN ARE THE PROPERTY OF SCHNEIDER ELECTRIC AND SHALL NOT BE COPIED, REPRODUCED OR USED IN WHOLE OR IN PART, AS THE BASIS FOR THE MANUFACTURE OR ELECTRIC. THIS DRAWING IS BASED UPON LATEST AVAILABLE INFORMATION AND IS SUBJECT TO CHANGE WITHOUT NOTICE.

DEVICE RATING		ACCESSORIES	
DEVICE	RATING	TYPE	MAKE
Q1	1000A, 600V	3P MCSW	APC by Schneider Electric
Q2	600A/800A, 600V	4P MCCB	ABB
Q3	800A, 600V	4P MCSW	ABB
Q5	800A, 600V	3P MCSW	ABB
DC DISCONNECT	400A, 600V DC	4P MCSW	ABB

Symmetra PX 500 kW 480 V Dual Mains with Maintenance Bypass (4 Wire Output) and Line-Up-And-Match Batteries – Top Feed

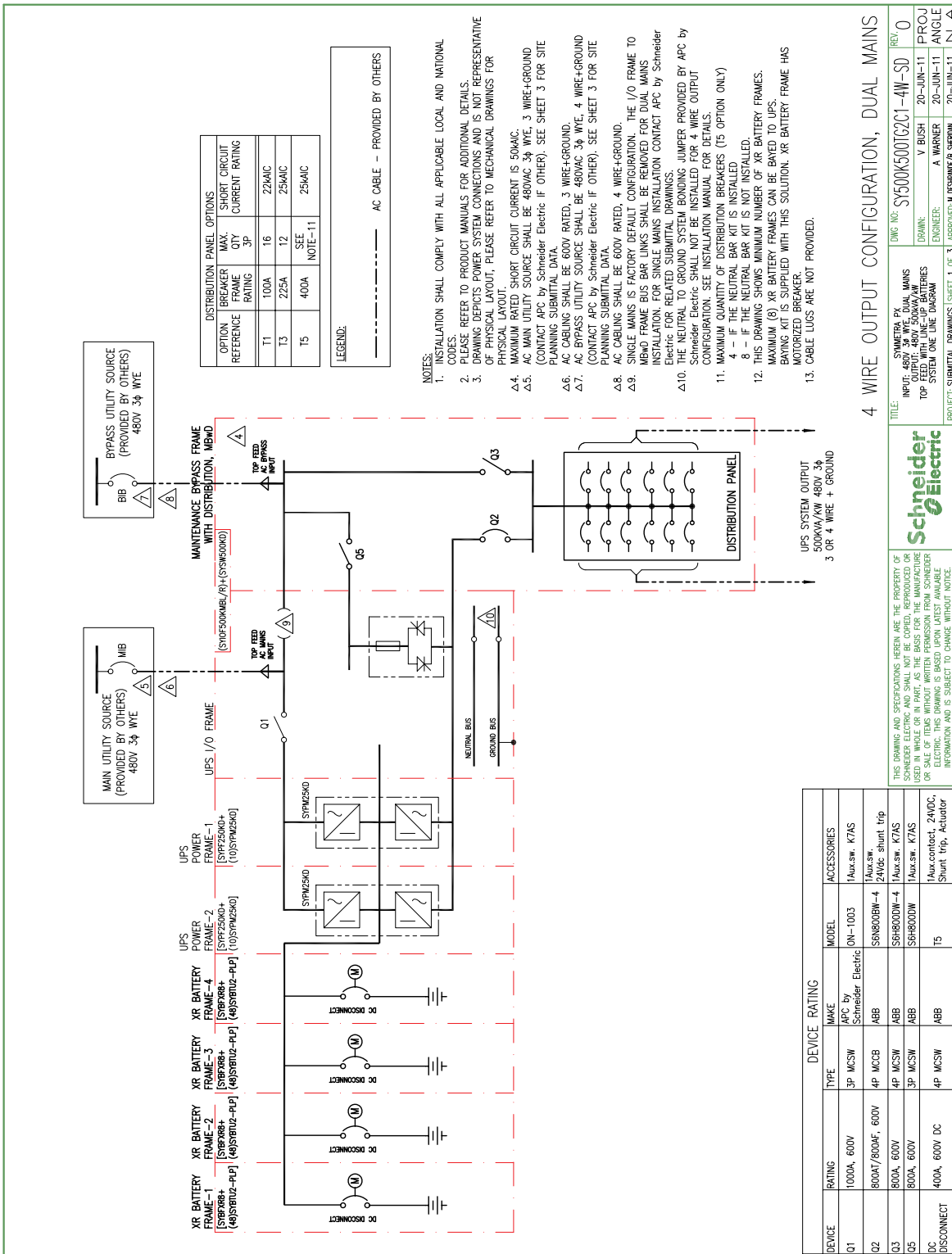

DISTRIBUTION PANEL OPTIONS			
OPTION REFERENCE	BREAKER RATING	MAX. QTY 3P	SHORT CIRCUIT CURRENT RATING
T1	100A	16	22kAIC
T3	225A	12	25kAIC
T5	400A	SEE NOTE-11	25kAIC

LEGEND:
 - - - - - AC CABLE - PROVIDED BY OTHERS

- NOTES:
1. INSTALLATION SHALL COMPLY WITH ALL APPLICABLE LOCAL AND NATIONAL CODES.
 2. PLEASE REFER TO PRODUCT MANUALS FOR ADDITIONAL DETAILS.
 3. DRAWING DEPICTS POWER SYSTEM CONNECTIONS AND IS NOT REPRESENTATIVE OF PHYSICAL LAYOUT, PLEASE REFER TO MECHANICAL DRAWINGS FOR PHYSICAL LAYOUT.
 4. MAXIMUM RATED SHORT CIRCUIT CURRENT IS 50kAIC.
 - 4.1. MAXIMUM RATED SHORT CIRCUIT CURRENT IS 50kAIC. (CONTACT APC by Schneider Electric IF OTHER). SEE SHEET 3 FOR SITE PLANNING SUBMITTAL DATA.
 - 4.2. AC CABLING SHALL BE 600V RATED, 3 WIRE+GROUND.
 - 4.3. AC BYPASS UTILITY SOURCE SHALL BE 480VAC 3 ϕ WYE, 4 WIRE+GROUND (CONTACT APC by Schneider Electric IF OTHER). SEE SHEET 3 FOR SITE PLANNING SUBMITTAL DATA.
 - 4.4. AC CABLING SHALL BE 600V RATED, 4 WIRE+GROUND.
 - 4.5. SINGLE MAINS IS FACTORY DEFAULT CONFIGURATION. THE I/O FRAME TO MEND FRAME BUS LINKS SHALL BE REMOVED FOR DUAL MAINS INSTALLATION. FOR SINGLE MAINS INSTALLATION CONTACT APC by Schneider Electric FOR RELATED SUBMITTAL DRAWINGS.
 - 4.6. THE NEUTRAL TO GROUND SYSTEM BONDING JUMPER PROVIDED BY APC BY Schneider Electric SHALL NOT BE INSTALLED FOR 4 WIRE OUTPUT CONFIGURATION. SEE INSTALLATION MANUAL FOR DETAILS.
 11. MAXIMUM QUANTITY OF DISTRIBUTION BREAKERS (15 OPTION ONLY)
 - 4 - IF THE NEUTRAL BAR KIT IS NOT INSTALLED.
 - 8 - IF THE NEUTRAL BAR KIT IS INSTALLED.
 12. THIS DRAWING SHOWS MINIMUM NUMBER OF XR BATTERY FRAMES. MAXIMUM (8) XR BATTERY FRAMES CAN BE BAYED TO UPS. BAYING KIT IS SUPPLIED WITH THIS SOLUTION. XR BATTERY FRAME HAS MOTORIZED BREAKER.
 13. CABLE LUGS ARE NOT PROVIDED.

4 WIRE OUTPUT CONFIGURATION, DUAL MAINS

TITLE: 4 WIRE OUTPUT CONFIGURATION, DUAL MAINS
 SHYMETER BY: SY500K500T2C1-4W-SD
 INPUT: 480V 3 ϕ WYE, DUAL MAINS
 OUTPUT: 480V 500kVA/4W
 TOP SYSTEM ONE LINE DIAGRAM
 DWS NO: SY500K500T2C1-4W-SD
 REV: 0
 V BUSH 20-JUN-11
 A WARNER 20-JUN-11
 PROJECT: SUBMITTAL DRAWINGS SHEET 1 OF 3 APPROVED BY: [Signature]
 PROJECT: SUBMITTAL DRAWINGS SHEET 1 OF 3 APPROVED BY: [Signature]



THIS DRAWING AND SPECIFICATIONS HEREBY ARE THE PROPERTY OF SCHNEIDER ELECTRIC AND SHALL NOT BE COPIED, REPRODUCED OR USED IN WHOLE OR IN PART AS THE BASIS FOR THE MANUFACTURE OR SALE OF ITEMS WITHOUT WRITTEN PERMISSION FROM SCHNEIDER ELECTRIC. THIS DRAWING IS BASED UPON LATEST AVAILABLE INFORMATION AND IS SUBJECT TO CHANGE WITHOUT NOTICE.

Symmetra PX 500 kW 480 V Single Mains with Maintenance Bypass (4 Wire Output) and Line-Up-And-Match Batteries – Bottom Feed

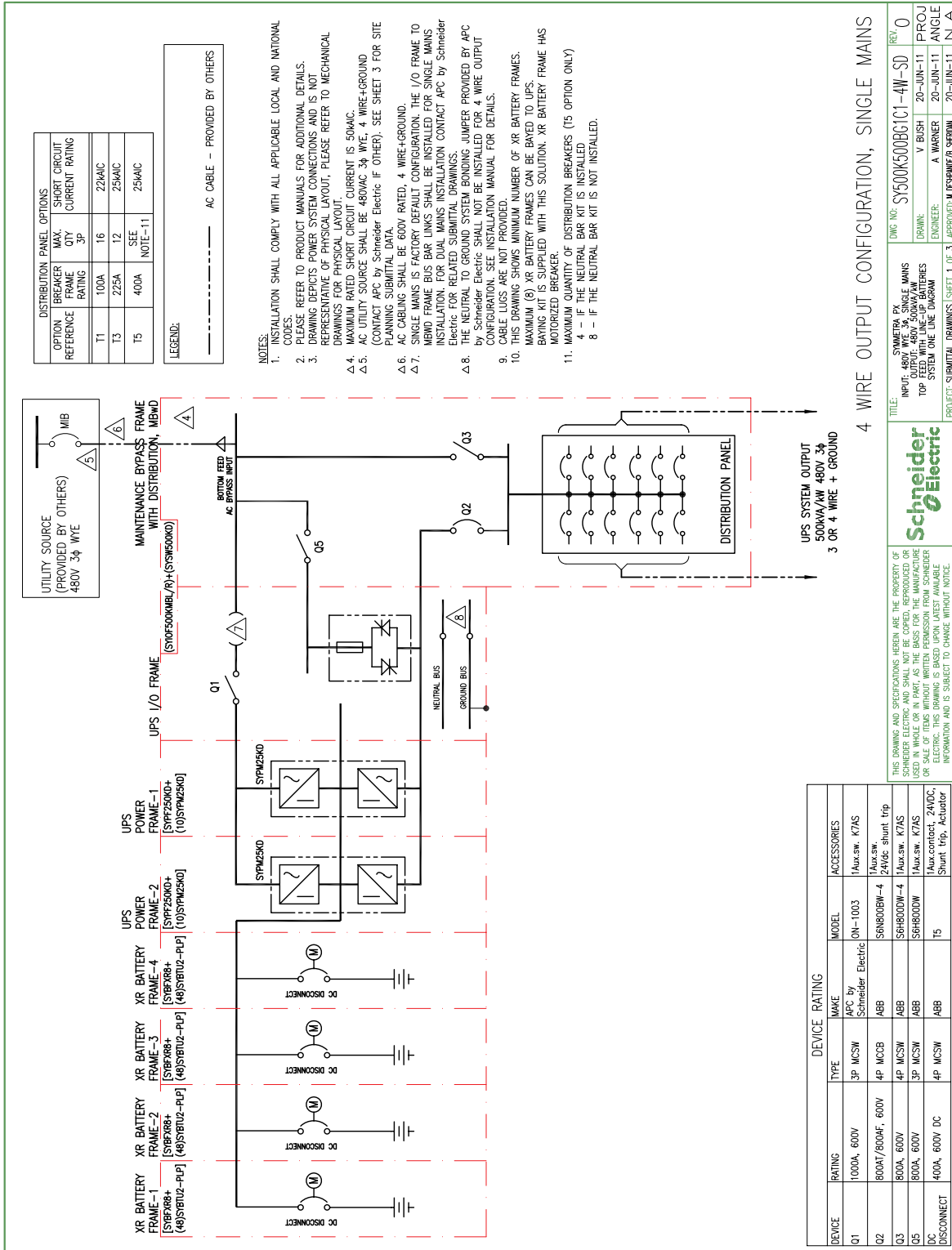

Symmetra PX 500 kW 480 V Dual Mains with Maintenance Bypass (4 Wire Output) and Line-Up-And-Match Batteries – Bottom Feed

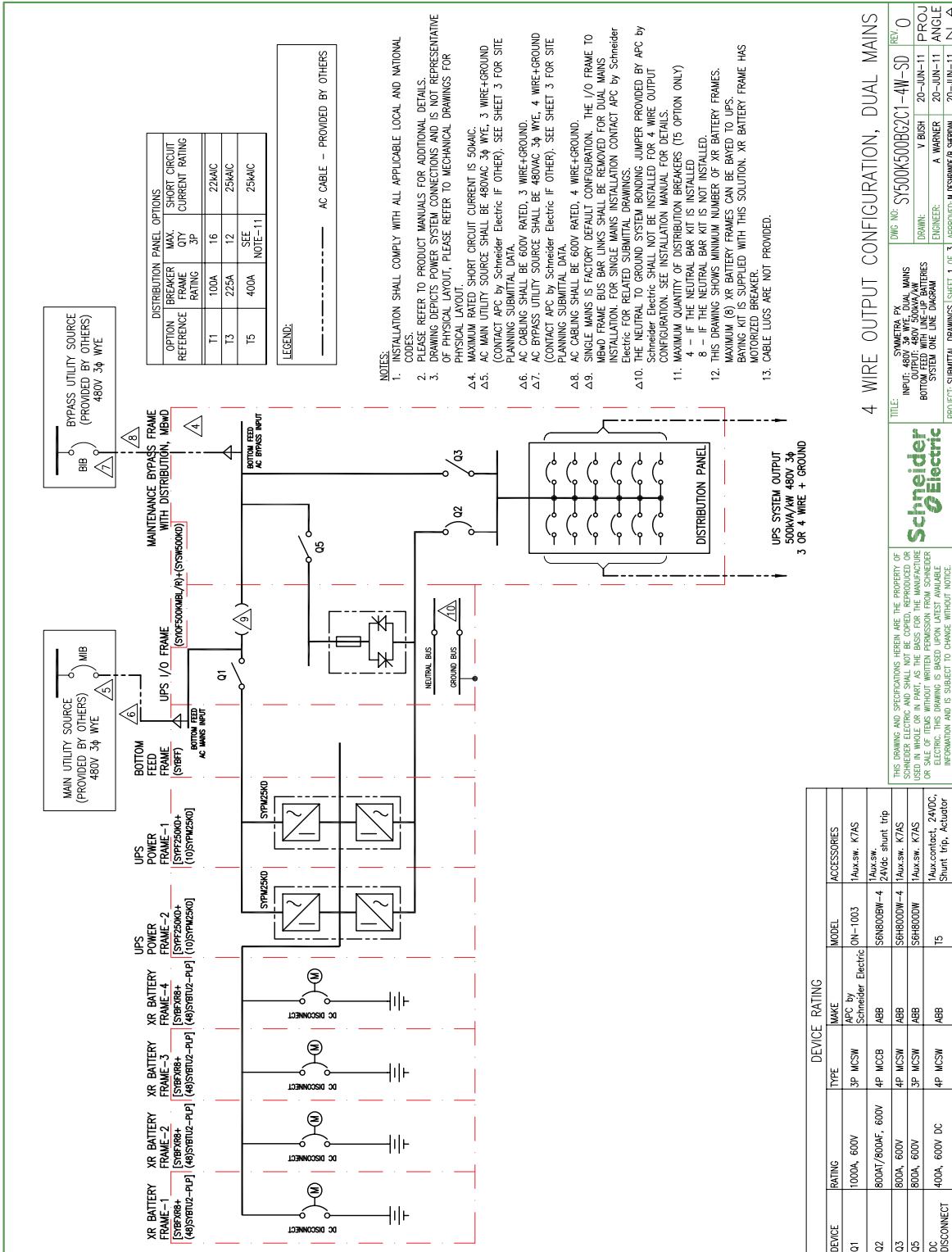

4 WIRE OUTPUT CONFIGURATION, DUAL MAINS

TITLE: SYMMETRA PX 500kW 480V 3 ϕ WYE DUAL MAINS OUTPUT 480V 500KVA/W 3 ϕ WYE 3 OR 4 WIRE + GROUND SYSTEM ONE LINE DIAGRAM

DWG NO: SY500K0500B02C1-4W-SD

REV: 0

PROJ: 20-JUN-11

ANG: N.A.

ENGINEER: A. WARDNER

APPROVED: M. WESPAWETZ SHERWIN

SHEET: 1 OF 3

Schneider Electric

THIS DRAWING AND SPECIFICATIONS HEREIN ARE THE PROPERTY OF SCHNEIDER ELECTRIC AND SHALL NOT BE COPIED, REPRODUCED OR USED IN WHOLE OR IN PART, AS THE BASIS FOR THE MANUFACTURE OR SALE OF ITEMS WITHOUT WRITTEN PERMISSION FROM SCHNEIDER ELECTRIC. THIS DRAWING IS BASED UPON LATEST AVAILABLE INFORMATION AND IS SUBJECT TO CHANGE WITHOUT NOTICE.

Options

Hardware Options

Breakers

NOTE: 4-pole breakers are not available as an option in North America.

- T1 breaker kit for unsupported breaker amperages with current transformer without adaptors
- T3 breaker kit for unsupported breaker amperages with current transformer without adaptors
- 3-Pole circuit breaker, 60 A, T1 Type
- 3-Pole circuit breaker, 70 A, T1 Type
- 3-Pole circuit breaker, 80 A, T1 Type
- 3-Pole circuit breaker, 90 A, T1 Type
- 3-Pole circuit breaker, 100 A, T1 Type
- 3-Pole circuit breaker, 125 A, T3 Type
- 3-Pole circuit breaker, 150 A, T3 Type
- 3-Pole circuit breaker, 175 A, T3 Type
- 3-Pole circuit breaker, 200 A, T3 Type
- 3-Pole circuit breaker, 225 A, T3 Type
- 3-Pole circuit breaker, 300 A, T5 Type
- 3-Pole circuit breaker, 400 A, T5 Type
- 4-Pole circuit breaker, 60 A, T1 Type
- 4-Pole circuit breaker, 70 A, T1 Type
- 4-Pole circuit breaker, 80 A, T1 Type
- 4-Pole circuit breaker, 90 A, T1 Type
- 4-Pole circuit breaker, 100 A, T1 Type
- 4-Pole circuit breaker, 125 A, T3 Type
- 4-Pole circuit breaker, 150 A, T3 Type
- 4-Pole circuit breaker, 175 A, T3 Type
- 4-Pole circuit breaker, 200 A, T3 Type
- 4-Pole circuit breaker, 225 A, T3 Type
- Adaptor for T1 Type circuit breaker, 3 Pole
- Adaptor for T3 Type circuit breaker, 3 Pole
- Adaptor for T5 Type circuit breaker, 3 Pole

Symmetra Battery Systems

- Battery breaker cabinet with fuse kit for third party batteries
- Battery breaker cabinet
- Battery cabinet for up to 8 battery modules
- Battery cabinet for up to 8 battery modules and start up
- Battery cabinet with 8 battery modules and start up
- Battery sidecar for remote battery solution without fuse
- Battery sidecar for remote battery solution with 500 A fuse kit
- High performance battery module

- Value battery cabinet pair
- Pair of value battery cabinets with 7 minute battery @ 250 kW
- Pair of value battery cabinets with 7 minute battery @ 250 kW and including battery management

Other Options

- Air filters
- Optional terminal blocks
- 3.rd party switch gear kit
- Paralleling cable
- Seismic kits

Configuration Options

- Single or dual feed.
- Top or bottom feed.
- Internal N+1 redundancy.
- Unity power factor corrected.
- Automatic internal bypass.
- Toolless module replacement.
- Swappable static bypass switch.
- Swappable power modules.
- Swappable 9AH batteries.
- Up to eight external runtime frames with batteries.
- Main and redundant intelligence modules.
- Parallel up to four units for capacity or redundancy.
- Custom switchgear for parallel installations.
- Standard battery cabinet for third-party front-access batteries.
- Secondary network management card.
- SmartSlot communications cards.
- StruxureWare Central compatible.
- Network manageable.
- Generator compatible.
- Remote battery installations.
- Seismic bracket kits.
- External synchronization: Synchronize the output of the UPS with any other independent source for use with downstream static transfer switches.
- MegaTie: The UPS or block of UPSs may have the ability to transfer the load between them without active load sharing.
- EcoMode: In bypass operation, an even higher operating efficiency may be achieved without sacrificing protection when there are good power conditions. Depending on configuration, efficiency can exceed 99%.
- Virtual display: Download the display interface to your laptop or personal computer and monitor a complete system with up to 4 UPSs in parallel.

Limited Factory Warranty

One-Year Factory Warranty

The limited warranty provided by Schneider Electric in this Statement of Limited Factory Warranty applies only to products you purchase for your commercial or industrial use in the ordinary course of your business.

Terms of Warranty

Schneider Electric warrants that the product shall be free from defects in materials and workmanship for a period of one year from the date of product start-up when start-up is performed by Schneider Electric-authorized service personnel and occurs within six months of the Schneider Electric shipment date. This warranty covers repairing or replacing any defective parts including on-site labor and travel. In the event that the product fails to meet the foregoing warranty criteria, the warranty covers repairing or replacing defective parts at the sole discretion of Schneider Electric for a period of one year from the shipment date. For Schneider Electric cooling solutions, this warranty does not cover circuit breaker resetting, loss of refrigerant, consumables, or preventive maintenance items. Repair or replacement of a defective product or part thereof does not extend the original warranty period. Any parts furnished under this warranty may be new or factory-remanufactured.

Non-transferable Warranty

This warranty is extended to the first person, firm, association or corporation (herein referred to by "You" or "Your") for whom the Schneider Electric product specified herein has been purchased. This warranty is not transferable or assignable without the prior written permission of Schneider Electric.

Assignment of Warranties

Schneider Electric will assign you any warranties which are made by manufacturers and suppliers of components of the Schneider Electric product and which are assignable. Any such warranties are assigned "AS IS" and Schneider Electric makes no representation as to the effectiveness or extent of such warranties, assumes no responsibility for any matters which may be warranted by such manufacturers or suppliers and extends no coverage under this Warranty to such components.

Drawings, Descriptions

Schneider Electric warrants for the warranty period and on the terms of the warranty set forth herein that the Schneider Electric product will substantially conform to the descriptions contained in the Schneider Electric Official Published Specifications or any of the drawings certified and agreed to by contract with Schneider Electric if applicable thereto ("Specifications"). It is understood that the Specifications are not warranties of performance and not warranties of fitness for a particular purpose.

Exclusions

Schneider Electric shall not be liable under the warranty if its testing and examination disclose that the alleged defect in the product does not exist or was caused by end user or any third person misuse, negligence, improper installation or testing. Further, Schneider Electric shall not be liable under the warranty for unauthorized attempts to repair or modify wrong or inadequate electrical voltage

or connection, inappropriate on-site operation conditions, corrosive atmosphere, repair, installation, start-up by non-Schneider Electric designated personnel, a change in location or operating use, exposure to the elements, Acts of God, fire, theft, or installation contrary to Schneider Electric recommendations or specifications or in any event if the Schneider Electric serial number has been altered, defaced, or removed, or any other cause beyond the range of the intended use.

THERE ARE NO WARRANTIES, EXPRESS OR IMPLIED, BY OPERATION OF LAW OR OTHERWISE, OF PRODUCTS SOLD, SERVICED OR FURNISHED UNDER THIS AGREEMENT OR IN CONNECTION HEREWITH. SCHNEIDER ELECTRIC DISCLAIMS ALL IMPLIED WARRANTIES OF MERCHANTABILITY, SATISFACTION AND FITNESS FOR A PARTICULAR PURPOSE. SCHNEIDER ELECTRIC EXPRESS WARRANTIES WILL NOT BE ENLARGED, DIMINISHED, OR AFFECTED BY AND NO OBLIGATION OR LIABILITY WILL ARISE OUT OF, SCHNEIDER ELECTRIC RENDERING OF TECHNICAL OR OTHER ADVICE OR SERVICE IN CONNECTION WITH THE PRODUCTS. THE FOREGOING WARRANTIES AND REMEDIES ARE EXCLUSIVE AND IN LIEU OF ALL OTHER WARRANTIES AND REMEDIES. THE WARRANTIES SET FORTH ABOVE CONSTITUTE SCHNEIDER ELECTRIC SOLE LIABILITY AND PURCHASER'S EXCLUSIVE REMEDY FOR ANY BREACH OF SUCH WARRANTIES. SCHNEIDER ELECTRIC WARRANTIES RUN ONLY TO PURCHASER AND ARE NOT EXTENDED TO ANY THIRD PARTIES.

IN NO EVENT SHALL SCHNEIDER ELECTRIC, ITS OFFICERS, DIRECTORS, AFFILIATES OR EMPLOYEES BE LIABLE FOR ANY FORM OF INDIRECT, SPECIAL, CONSEQUENTIAL OR PUNITIVE DAMAGES, ARISING OUT OF THE USE, SERVICE OR INSTALLATION, OF THE PRODUCTS, WHETHER SUCH DAMAGES ARISE IN CONTRACT OR TORT, IRRESPECTIVE OF FAULT, NEGLIGENCE OR STRICT LIABILITY OR WHETHER SCHNEIDER ELECTRIC HAS BEEN ADVISED IN ADVANCE OF THE POSSIBILITY OF SUCH DAMAGES, SPECIFICALLY, SCHNEIDER ELECTRIC IS NOT LIABLE FOR ANY COSTS, SUCH AS LOST PROFITS OR REVENUE, LOSS OF EQUIPMENT, LOSS OF USE OF EQUIPMENT, LOSS OF SOFTWARE, LOSS OF DATA, COSTS OF SUBSTITUANTS, CLAIMS BY THIRD PARTIES, OR OTHERWISE.

NO SALESMAN, EMPLOYEE OR AGENT OF SCHNEIDER ELECTRIC IS AUTHORIZED TO ADD TO OR VARY THE TERMS OF THIS WARRANTY. WARRANTY TERMS MAY BE MODIFIED, IF AT ALL, ONLY IN WRITING SIGNED BY AN SCHNEIDER ELECTRIC OFFICER AND LEGAL DEPARTMENT.

Warranty Claims

Customers with warranty claims issues may access the SCHNEIDER ELECTRIC worldwide customer support network through the SCHNEIDER ELECTRIC web site: <http://www.schneider-electric.com>. Select your country from the country selection pull-down menu. Open the Support tab at the top of the web page to obtain contact information for customer support in your region.

Schneider Electric
35 rue Joseph Monier
92500 Rueil Malmaison
France

+ 33 (0) 1 41 29 70 00



* 9 9 0 - 3 8 8 0 J - 0 0 1 *

As standards, specifications, and design change from time to time,
please ask for confirmation of the information given in this publication.