

Symmetra PX 20 kW

InfrastruXure 208 V

Installation

01/2016



Legal Information

The Schneider Electric brand and any registered trademarks of Schneider Electric Industries SAS referred to in this guide are the sole property of Schneider Electric SA and its subsidiaries. They may not be used for any purpose without the owner's permission, given in writing. This guide and its content are protected, within the meaning of the French intellectual property code (Code de la propriété intellectuelle français, referred to hereafter as "the Code"), under the laws of copyright covering texts, drawings and models, as well as by trademark law. You agree not to reproduce, other than for your own personal, noncommercial use as defined in the Code, all or part of this guide on any medium whatsoever without Schneider Electric's permission, given in writing. You also agree not to establish any hypertext links to this guide or its content. Schneider Electric does not grant any right or license for the personal and noncommercial use of the guide or its content, except for a non-exclusive license to consult it on an "as is" basis, at your own risk. All other rights are reserved.

Electrical equipment should be installed, operated, serviced, and maintained only by qualified personnel. No responsibility is assumed by Schneider Electric for any consequences arising out of the use of this material.

As standards, specifications, and designs change from time to time, please ask for confirmation of the information given in this publication.

Table of Contents

| | |
|---|----|
| Important Safety Information | 5 |
| Safety Precautions | 6 |
| Electrical Safety | 8 |
| Battery Safety | 9 |
| Specifications | 11 |
| AC Input Specifications | 11 |
| AC Bypass Specifications | 11 |
| AC Output Specifications | 11 |
| Battery Specifications | 12 |
| Heat Dissipation | 12 |
| Fuses and Breakers | 12 |
| Protection Type and Rating | 12 |
| System DC Input Protection | 13 |
| Wiring | 13 |
| Wraparound Bypass Configuration / Rating | 13 |
| Distribution | 13 |
| Recommended Cable Sizes | 14 |
| Torque Specifications | 14 |
| Mechanical Assembly | 15 |
| Product Overview | 15 |
| Clearance | 18 |
| Level the Cabinets | 19 |
| Prepare Modular Battery Cabinet for Installation (Option) | 21 |
| Rearrange Side Panels for Line-Up and Match Modular Battery Cabinets | 21 |
| Prepare for Cables in a Bottom Cable Entry System | 22 |
| Prepare for Cables in a Rear Cable Entry System | 23 |
| Connect the Input Power Cables | 25 |
| Connect the Output Power Cables in the PDU | 29 |
| Connect Battery Cables in the UPS (Option) | 32 |
| Connect Emergency Power Off (EPO) | 33 |
| Connect Communication Cables | 36 |
| Install Modular Battery Cabinet (Option) | 39 |
| Connect Battery Cables in Modular Battery Cabinet | 39 |
| Connect the Battery Cables between the Modular Battery Cabinets | 39 |

Important Safety Information

Read these instructions carefully and look at the equipment to become familiar with it before trying to install, operate, service or maintain it. The following safety messages may appear throughout this manual or on the equipment to warn of potential hazards or to call attention to information that clarifies or simplifies a procedure.



The addition of this symbol to a “Danger” or “Warning” safety message indicates that an electrical hazard exists which will result in personal injury if the instructions are not followed.



This is the safety alert symbol. It is used to alert you to potential personal injury hazards. Obey all safety messages with this symbol to avoid possible injury or death.

| ⚠ DANGER |
|---|
| <p>DANGER indicates a hazardous situation which, if not avoided, will result in death or serious injury.</p> <p>Failure to follow these instructions will result in death or serious injury.</p> |

| ⚠ WARNING |
|---|
| <p>WARNING indicates a hazardous situation which, if not avoided, could result in death or serious injury.</p> <p>Failure to follow these instructions can result in death, serious injury, or equipment damage.</p> |

| ⚠ CAUTION |
|--|
| <p>CAUTION indicates a hazardous situation which, if not avoided, could result in minor or moderate injury.</p> <p>Failure to follow these instructions can result in injury or equipment damage.</p> |

| NOTICE |
|--|
| <p>NOTICE is used to address practices not related to physical injury. The safety alert symbol shall not be used with this type of safety message.</p> <p>Failure to follow these instructions can result in equipment damage.</p> |

Please Note

Electrical equipment should only be installed, operated, serviced, and maintained by qualified personnel. No responsibility is assumed by Schneider Electric for any consequences arising out of the use of this material.

A qualified person is one who has skills and knowledge related to the construction, installation, and operation of electrical equipment and has received safety training to recognize and avoid the hazards involved.

Safety Precautions

⚠ DANGER

HAZARD OF ELECTRIC SHOCK, EXPLOSION, OR ARC FLASH

All safety instructions in this document must be read, understood and followed.

Failure to follow these instructions will result in death or serious injury.

⚠ DANGER

HAZARD OF ELECTRIC SHOCK, EXPLOSION, OR ARC FLASH

Read all instructions in the Installation Manual before installing or working on this UPS system.

Failure to follow these instructions will result in death or serious injury.

⚠ DANGER

HAZARD OF ELECTRIC SHOCK, EXPLOSION, OR ARC FLASH

Do not install the UPS system until all construction work has been completed and the installation room has been cleaned.

Failure to follow these instructions will result in death or serious injury.

⚠ DANGER

HAZARD OF ELECTRIC SHOCK, EXPLOSION, OR ARC FLASH

- The product must be installed according to the specifications and requirements as defined by Schneider Electric. It concerns in particular the external and internal protections (upstream breakers, battery breakers, cabling, etc.) and environmental requirements. No responsibility is assumed by Schneider Electric if these requirements are not respected.
- After the UPS system has been electrically wired, do not start up the system. Startup must only be performed by Schneider Electric.

Failure to follow these instructions will result in death or serious injury.

⚠ DANGER

HAZARD OF ELECTRIC SHOCK, EXPLOSION, OR ARC FLASH

The UPS System must be installed according to local and national regulations. Install the UPS according to:

- IEC 60364 (including 60364-4-41 - protection against electric shock, 60364-4-42 - protection against thermal effect, and 60364-4-43 - protection against overcurrent), **or**
- NEC NFPA 70, **or**
- Canadian Electrical Code (C22.1, Part 1)

depending on which one of the standards apply in your local area.

Failure to follow these instructions will result in death or serious injury.

⚠ DANGER**HAZARD OF ELECTRIC SHOCK, EXPLOSION, OR ARC FLASH**

- Install the UPS system in a temperature controlled indoor environment free of conductive contaminants and humidity.
- Install the UPS system on a non-flammable, level and solid surface (e.g. concrete) that can support the weight of the system.

Failure to follow these instructions will result in death or serious injury.

⚠ DANGER**HAZARD OF ELECTRIC SHOCK, EXPLOSION, OR ARC FLASH**

The UPS is not designed for and must therefore not be installed in the following unusual operating environments:

- Damaging fumes
- Explosive mixtures of dust or gases, corrosive gases, or conductive or radiant heat from other sources
- Moisture, abrasive dust, steam or in an excessively damp environment
- Fungus, insects, vermin
- Salt-laden air or contaminated cooling refrigerant
- Pollution degree higher than 2 according to IEC 60664-1
- Exposure to abnormal vibrations, shocks, and tilting
- Exposure to direct sunlight, heat sources, or strong electromagnetic fields

Failure to follow these instructions will result in death or serious injury.

⚠ DANGER**HAZARD OF ELECTRIC SHOCK, EXPLOSION, OR ARC FLASH**

Do not drill or cut holes for cables or conduits with the gland plates installed and do not drill or cut holes in close proximity to the UPS.

Failure to follow these instructions will result in death or serious injury.

⚠ WARNING**HAZARD OF ARC FLASH**

Do not make mechanical changes to the product (including removal of cabinet parts or drilling/cutting of holes) that are not described in the Installation Manual.

Failure to follow these instructions can result in death, serious injury, or equipment damage.

⚠ WARNING**HAZARD OF OVERHEATING**

Respect the space requirements around the UPS system and do not cover the product's ventilation openings when the UPS system is in operation.

Failure to follow these instructions can result in death, serious injury, or equipment damage.

⚠ WARNING

HAZARD OF EQUIPMENT DAMAGE

Do not connect the UPS output to regenerative load systems including photovoltaic systems and speed drives.

Failure to follow these instructions can result in death, serious injury, or equipment damage.

Electrical Safety

⚠ DANGER

HAZARD OF ELECTRIC SHOCK, EXPLOSION OR ARC FLASH

- Electrical equipment must be installed, operated, serviced, and maintained only by qualified personnel.
- The UPS system must be installed in a room with restricted access (qualified personnel only).
- Apply appropriate personal protective equipment (PPE) and follow safe electrical work practices.
- Turn off all power supplying the UPS system before working on or inside the equipment.
- Before working on the UPS system, check for hazardous voltage between all terminals including the protective earth.
- The UPS contains an internal energy source. Hazardous voltage can be present even when disconnected from the utility/mains supply. Before installing or servicing the UPS system, ensure that the units are OFF and that utility/mains and batteries are disconnected. Wait five minutes before opening the UPS to allow the capacitors to discharge.
- A disconnection device (e.g. disconnection circuit breaker or switch) must be installed to enable isolation of the system from upstream power sources in accordance with local regulations. This disconnection device must be easily accessible and visible.
- The UPS must be properly earthed/grounded and due to a high leakage current, the earthing/grounding conductor must be connected first.

Failure to follow these instructions will result in death or serious injury.

⚠ DANGER

HAZARD OF ELECTRIC SHOCK, EXPLOSION, OR ARC FLASH

In systems where backfeed protection is not part of the standard design, an automatic isolation device (backfeed protection option or other device meeting the requirements of IEC/EN 62040-1 or UL 1778 4th Edition – depending on which of the two standards apply to your local area) must be installed to prevent hazardous voltage or energy at the input terminals of the isolation device. The device must open within 15 seconds after the upstream power supply fails and must be rated according to the specifications.

Failure to follow these instructions will result in death or serious injury.

When the UPS input is connected through external isolators that, when opened, isolate the neutral or when the automatic backfeed isolation is provided external to the equipment or is connected to an IT power distribution system, a label must be fitted at the UPS input terminals, and on all primary power isolators installed remote from the UPS area and on external access points between such isolators and the UPS, by the user, displaying the following text (or equivalent in a language which is acceptable in the country in which the UPS system is installed):

⚠ DANGER

HAZARD OF ELECTRIC SHOCK, EXPLOSION, OR ARC FLASH

Risk of Voltage Backfeed. Before working on this circuit: Isolate the UPS and check for hazardous voltage between all terminals including the protective earth.

Failure to follow these instructions will result in death or serious injury.

Battery Safety

⚠ DANGER

HAZARD OF ELECTRIC SHOCK, EXPLOSION, OR ARC FLASH

- Battery circuit breakers must be installed according to the specifications and requirements as defined by Schneider Electric.
- Servicing of batteries must only be performed or supervised by qualified personnel knowledgeable of batteries and the required precautions. Keep unqualified personnel away from batteries.
- Disconnect charging source prior to connecting or disconnecting battery terminals.
- Do not dispose of batteries in a fire as they can explode.
- Do not open, alter, or mutilate batteries. Released electrolyte is harmful to the skin and eyes. It may be toxic.

Failure to follow these instructions will result in death or serious injury.

⚠ DANGER

HAZARD OF ELECTRIC SHOCK, EXPLOSION, OR ARC FLASH

Batteries can present a risk of electric shock and high short-circuit current. The following precautions must be observed when working on batteries

- Remove watches, rings, or other metal objects.
- Use tools with insulated handles.
- Wear protective glasses, gloves and boots.
- Do not lay tools or metal parts on top of batteries.
- Disconnect the charging source prior to connecting or disconnecting battery terminals.
- Determine if the battery is inadvertently grounded. If inadvertently grounded, remove source from ground. Contact with any part of a grounded battery can result in electric shock. The likelihood of such shock can be reduced if such grounds are removed during installation and maintenance (applicable to equipment and remote battery supplies not having a grounded supply circuit).

Failure to follow these instructions will result in death or serious injury.

⚠ DANGER

HAZARD OF ELECTRIC SHOCK, EXPLOSION, OR ARC FLASH

When replacing batteries, always replace with the same type and number of batteries or battery packs.

Failure to follow these instructions will result in death or serious injury.

▲ CAUTION**RISK OF EQUIPMENT DAMAGE**

- Wait until the system is ready to be powered up before installing batteries in the system. The time duration from battery installation until the UPS system is powered up must not exceed 72 hours or 3 days.
- Batteries must not be stored more than six months due to the requirement of recharging. If the UPS system remains de-energized for a long period, we recommend that you energize the UPS system for a period of 24 hours at least once every month. This charges the batteries, thus avoiding irreversible damage.

Failure to follow these instructions can result in injury or equipment damage.

Specifications

AC Input Specifications

| | |
|---|--|
| Connection type | 3PH + N + PE |
| Nominal input current ¹ (A) | 61.3 |
| Maximum input current ² (A) | 70.9 |
| Input current limitation ³ (A) | 89.4 |
| Overload (A) | 115.0 A for 30 seconds (based on 150% overload on output) |
| Walk-in duration | 15 seconds (On retransfer from input to battery, RMS current will linearly ramp in for 10 seconds) |
| Input power factor | 0.99 at full load |
| Total harmonic distortion (THDI) | < 6% at full load |
| Nominal input voltage (V) | 208 |
| Input voltage range (V) | 166 ⁴ –240 ⁵ |
| Input frequency (Hz) | 40–70 (Outside of this range, the UPS will operate from battery power) |
| Maximum short-circuit withstand (kA) | 30 |

AC Bypass Specifications

| | |
|--------------------------------|--|
| Connection type | 3PH + N + PE |
| Input frequency (Hz) | 40 – 70 |
| Nominal input current (A) | 55.5 |
| Input voltage range (V) | 183–233 |
| Output current at overload (A) | 69.4 A at 125% load 555.1 A 1000% load for 500 ms |

AC Output Specifications

| | |
|--|---|
| Output voltage | 208 V |
| Connection type | 3PH + N + PE or 3PH + PE |
| Overload capacity | 150% for 30 seconds (normal operation) 150% continuously for 30 seconds (battery operation) 100% continuously (bypass operation) 1000% for 500 milliseconds (bypass operation) |
| Crest factor | 2.7 ⁶ |
| Load power factor | 0.5 to 1.0 |
| Output voltage – dynamic load response | +/-5 % (For load step 0% to 100% or 100% to 0%. Recovery back to steady state: < 60ms) |

1. Current that flows at nominal mains with batteries fully charged
2. Current that flows at nominal mains with charging batteries
3. The maximum continuous input current limit that can be drawn at low mains with charging batteries
4. At less than full load, the UPS will operate from mains/utility power to lower voltages
5. Above 240 V, the UPS will operate from battery power
6. No limit on applied crest factor, but the UPS regulates it down to 2.7

| | |
|--|---|
| Total harmonic distortion (THDU) | < 2% (100% resistive load) < 6% (Computer load as defined by EN50091-3/ IEC 62040-3) |
| Nominal output voltage (V) | 208 V |
| Output voltage range (V) | 205.9 V –1% to 210.1 V +1% |
| Output frequency (on line, in bypass) ⁷ | Synchronized to input over the range 57 Hz – 63 Hz |
| Output frequency – battery operation (Hz) | 50/60 |
| Slew rate (Hz/s) | Programmable to 0.25, 0.5, 1, 2, 4, and 6 |

Battery Specifications

| | |
|---|--|
| Battery type | Maintenance-free, sealed, lead-acid battery with suspended electrolyte – leakproof |
| Nominal voltage (VDC) | +/- 192 |
| Float voltage (VDC) | +/- 219 |
| End of discharge voltage (VDC) ⁸ | +/- 158 (96 cells at 1.65 V) |
| Temperature compensation | -320mV per °C (For temperatures greater than or equal to 20 °C) 0mV per °C (For temperatures less than 20 °C) |
| Battery charging ⁹ (kW) | 2 (N system – 2 power modules) |
| Maximum charging power ⁹ (kW) | 3 (N+1 system – 3 power modules) |
| Recharge time | 3 hours – to 90% capacity after full discharge |
| DC Ripple current ¹⁰ | <0.05 C |
| External battery input — Full load DC input current | 55.4 A at +/-192 V |
| External battery input — Maximum DC input current | 66.5 A at end of discharge +/-160 V |

Heat Dissipation

| Heat Dissipation | 50% load | 75% load | 100% load |
|----------------------------------|----------|----------|-----------|
| Batteries fully charged (BTU/hr) | 2038 | 2946 | 4117 |
| Batteries charging (BTU/hr) | 4494 | 5402 | 6573 |

NOTE: Batteries fully charged is a continuous rating. Batteries charging is for 3 hours max.
Charging losses are based on 3000 W and 95% charger electronic efficiency and 80% battery charging efficiency.

Fuses and Breakers

NOTE: The UPS unit’s withstand rating is 30,000 symmetrical Amps RMS

Protection Type and Rating

Condition: The UPS plus the following options (external to the UPS):

7. The following ranges can be selected: 40-60 Hz, 47-53 Hz, 49.9-50.1 Hz, 50-70 Hz, 57-63 Hz, and 59.9–60.1 Hz
8. May be higher at less than full load
9. May drop to lower values at low AC Mains
10. In normal operation at fully charged batteries

| Input Isolation Transformer | Protection Type | Notes |
|-----------------------------|------------------------------------|---|
| Present✓ | 90 A 3–pole breaker (30k AIC) | If available fault current is less than 30 kA, a lower AIC rated breaker may be used. Isolation transformer contains 90 A Class J fuse on primary. Each power module contains 2 pieces of 30 A fuse in parallel on its input. |
| Not present* | 90 A Class J current limiting fuse | Current limiting fuse is required to limit fault current through static switch. Each power module contains 2 pieces of 30 A fuse in parallel on its input. |

System DC Input Protection

⚠ DANGER

HAZARD OF ELECTRIC SHOCK, EXPLOSION, OR ARC FLASH

For third party external battery solutions, it is mandatory to install an external MCCB supplied by Schneider Electric containing two 100 A DC breakers for battery isolation.

Failure to follow these instructions will result in death or serious injury.

Wiring

| | Phase conductor size | Terminal lug diameter | Notes |
|-------------|----------------------|------------------------|---|
| Mains input | 3 AWG THHN | Saddle clamp- not stud | Wire AWG is recommended, copper, 194 °F (90 °C) per NEC 310-15 and 310-16 for 104 °F (40 °C) temperature environment and maximum of 3 current carrying conductors in a raceway. Local electrical codes must take precedence. Neutral conductor to be sized equal to phase current #2 AWG recommended. |
| DC input | 1/0 AWG | 8 mm | |

Recommended PE conductor size is 4 AWG. The PE lug diameter is 0.250 in (8 mm).

Wraparound Bypass Configuration / Rating

| | |
|----|--------------------------------|
| Q1 | 3 Pole 100 A 80% rated breaker |
| Q2 | 3 Pole 100 A 80% rated breaker |
| Q3 | 3 Pole 100 A 80% rated breaker |

Distribution

| |
|--|
| Square D QOB Panel 42 poles 3 Phase |
| Input via back feed 80A breaker mounted in panel |
| Capable of feeding 13 3–pole circuits |
| ATO configurable overhead whips |
| Internal Wiring #4AWG |

Recommended Cable Sizes

| | |
|-------------------------|------------------------------|
| Recommended cable sizes | 4 AWG THHN 1-inch conduit |
|-------------------------|------------------------------|

Torque Specifications

| | |
|---|-----------|
| Torque for main input terminals (in-lb) | 24.6–26.1 |
| PE lug (in-lb) | 124 |

Mechanical Assembly

1. In installations with modular battery cabinet(s): *Prepare Modular Battery Cabinet for Installation (Option)*, page 21 – Choose the appropriate procedure for your installation.
2. *Connect the Input Power Cables*, page 25 – Top or bottom cable entry.
3. *Connect the Output Power Cables in the PDU*, page 29
4. *Connect Emergency Power Off (EPO)*, page 33.
5. In installations with modular battery cabinets: *Connect Battery Cables in the UPS (Option)*, page 32.
6. *Connect Communication Cables*, page 36.
7. In installations with modular battery cabinets: *Install Modular Battery Cabinet (Option)*, page 39.
8. Level all cabinets with the leveling feet and a bubble level.

Product Overview

Front View of the UPS Cabinet

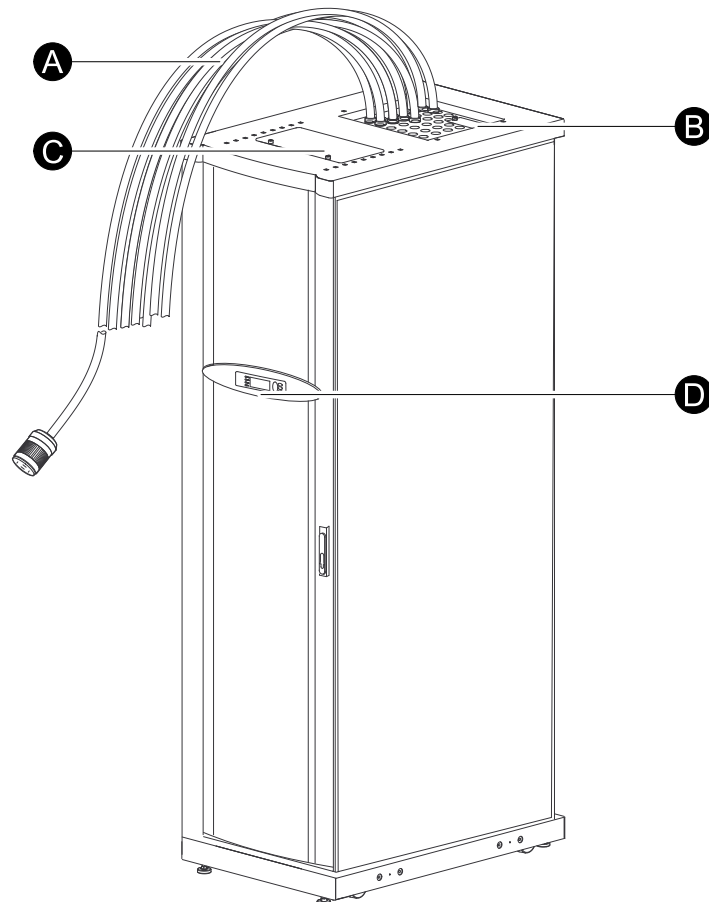

- A. Power cables
- B. Main input gland plate
- C. Wiring access cover
- D. Display interface

Front View of the UPS Cabinet

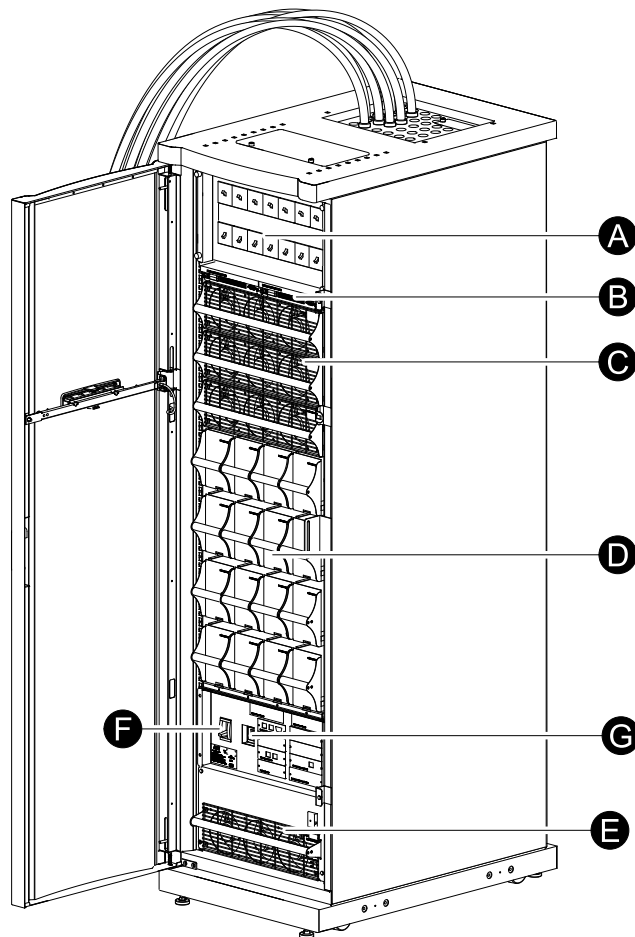

- A. 42-position circuit breaker panel
- B. Intelligence modules
- C. Power modules
- D. Modular batteries
- E. Static switch module
- F. DC Disconnect breaker
- G. System enable switch

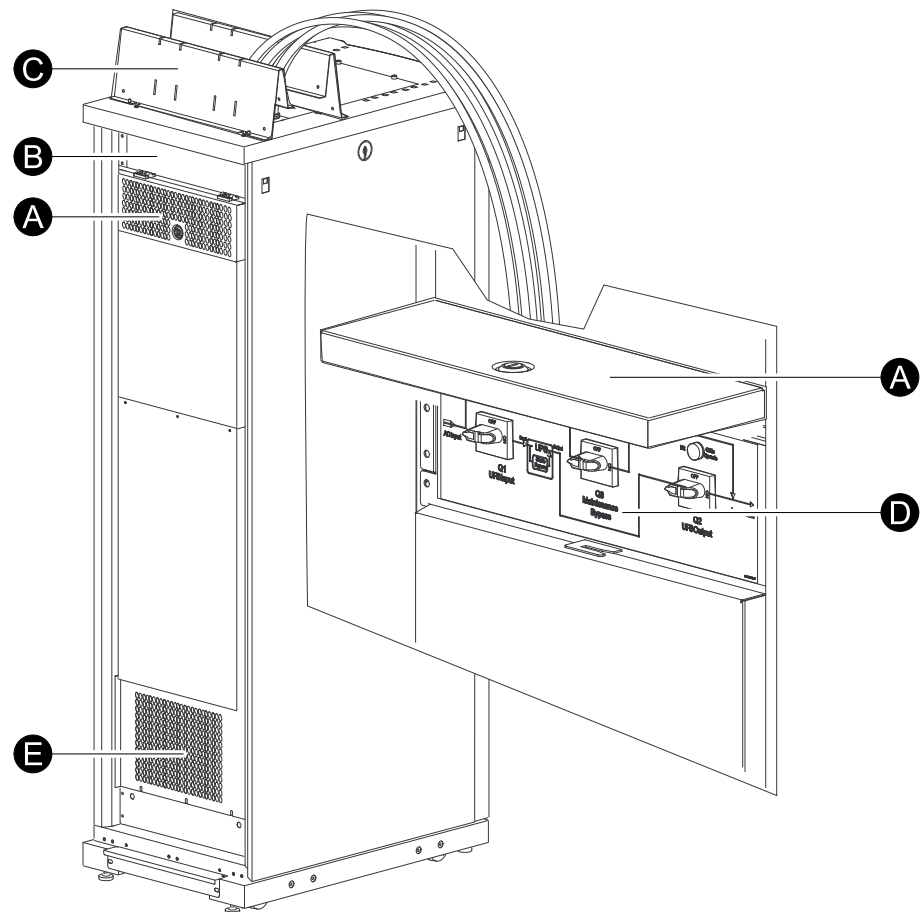
Rear View of the UPS Cabinet

- A. Maintenance bypass panel access
- B. Input terminal access (for top cable entry)
- C. PDU shielding troughs
- D. Maintenance bypass breakers
- E. Floor access cover to input terminals (for bottom cable entry – sold as an option), battery terminals, and communication wiring routing (if applicable)

Front View of the UPS Cabinet

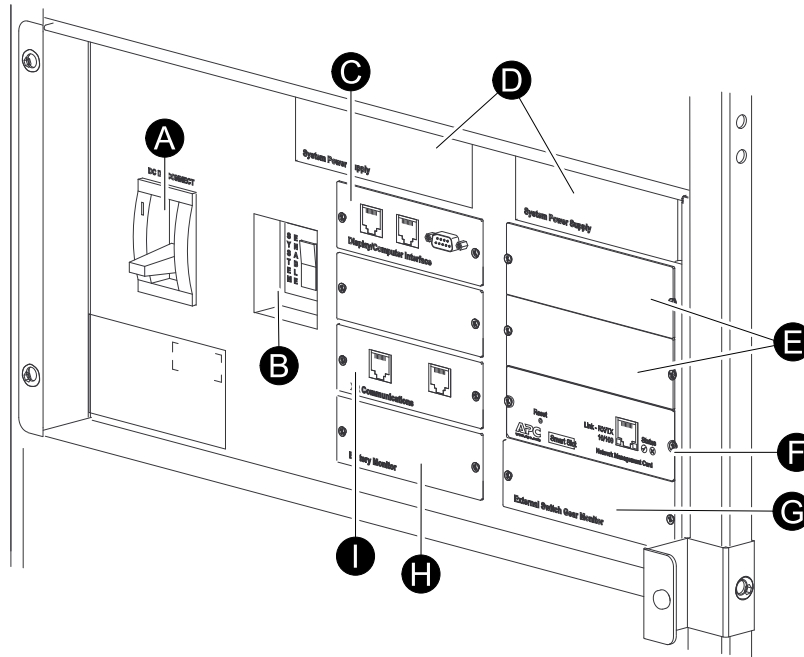

- A. DC disconnect breaker
- B. System enable switch
- C. Display/computer interface card
- D. System power supply cards
- E. Slots for accessory cards
- F. Network management card
- G. External switchgear monitoring card
- H. Battery monitoring card
- I. XR communications card (for external modular battery cabinets)

Clearance

NOTE: Clearance dimensions are published for airflow and service access only. Consult with the local safety codes and standards for additional requirements in your local area.

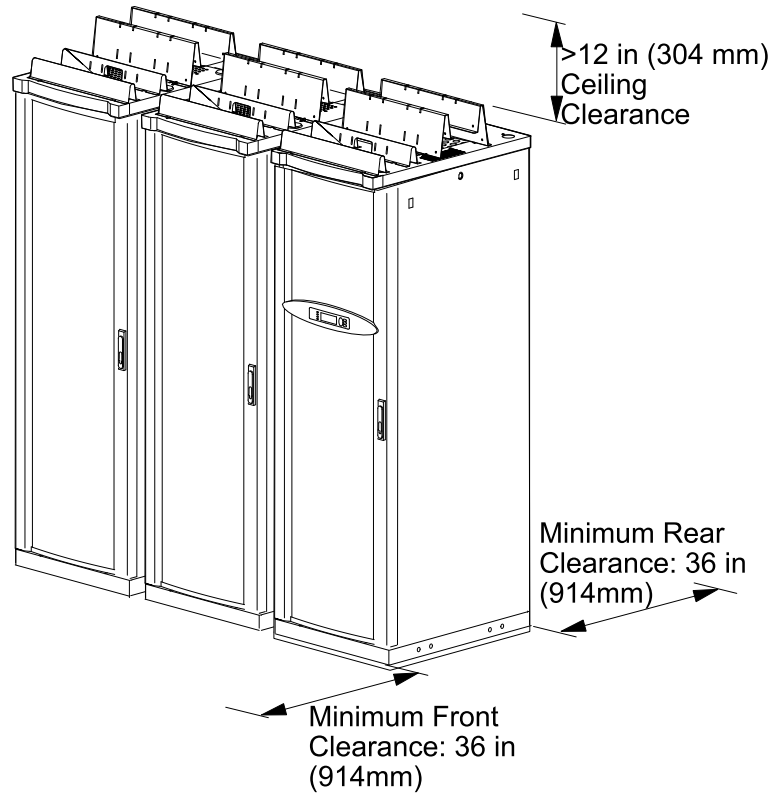

Level the Cabinets

▲ WARNING

TIP HAZARD

The system must be installed on a level floor. The leveling feet will stabilize the cabinet, but will not compensate for a badly sloped floor.

Failure to follow these instructions can result in death, serious injury, or equipment damage.

1. Use a screwdriver to lower the four leveling feet

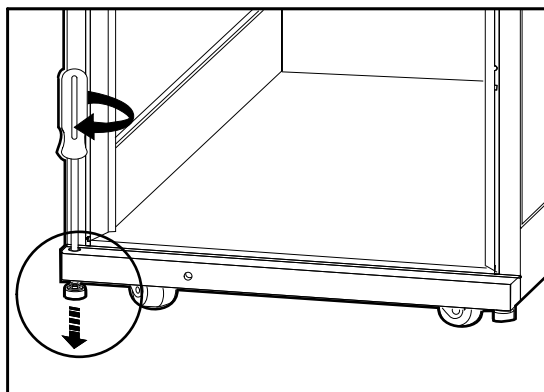

- Use a wrench to adjust the four leveling feet and ensure that the cabinet is level.

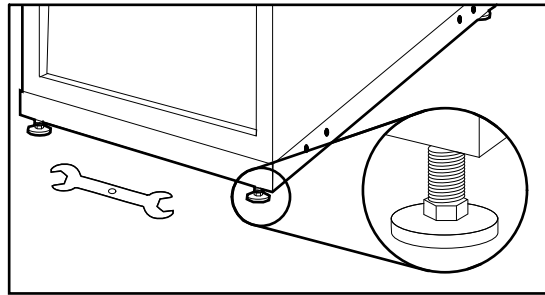

⚠ WARNING

TIP HAZARD

Do not move the cabinet after the leveling feet have been lowered.

Failure to follow these instructions can result in death, serious injury, or equipment damage.

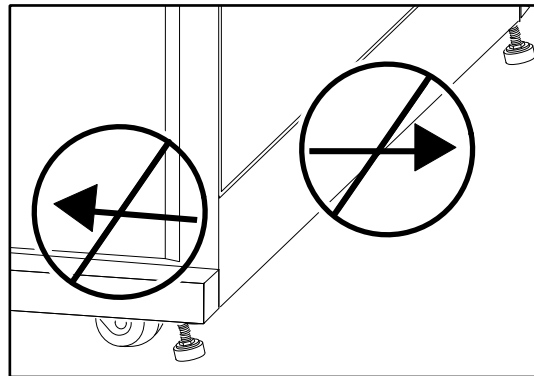

Prepare Modular Battery Cabinet for Installation (Option)

⚠ DANGER

HAZARD OF ELECTRIC SHOCK, EXPLOSION, OR ARC FLASH

Before working on the modular battery cabinet:

- Pull all modular battery units out to the red disconnect line (but not further unless the modular battery units are removed completely from the cabinet).
- Set all DC disconnect breakers or switches to the OFF position.
- Set the utility/mains power to OFF or LOCKED OUT position – in dual mains supply systems, ensure that both sources are in the OFF or LOCKED OUT position.

Failure to follow these instructions will result in death or serious injury.

Rearrange Side Panels for Line-Up and Match Modular Battery Cabinets

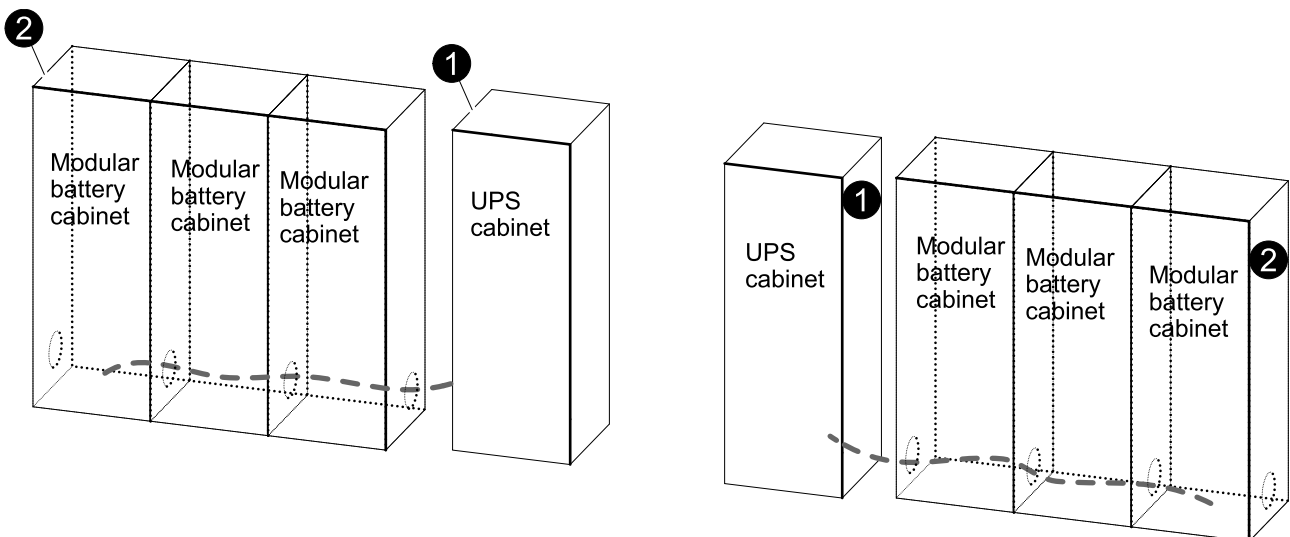

⚠ DANGER

HAZARD OF ELECTRIC SHOCK, EXPLOSION OR ARC FLASH

Remove and reinstall the PE cable connected to the cabinet side panels when rearranging the side panels. Use a 13 mm wrench.

Failure to follow these instructions will result in death or serious injury.

1. Remove the solid side panel on the UPS cabinet on the side facing towards the line-up and match modular cabinet(s).

2. Remove the side panel with knockouts on the modular battery cabinet facing away from the UPS/other modular battery cabinet(s).

Removal of the Side Panel

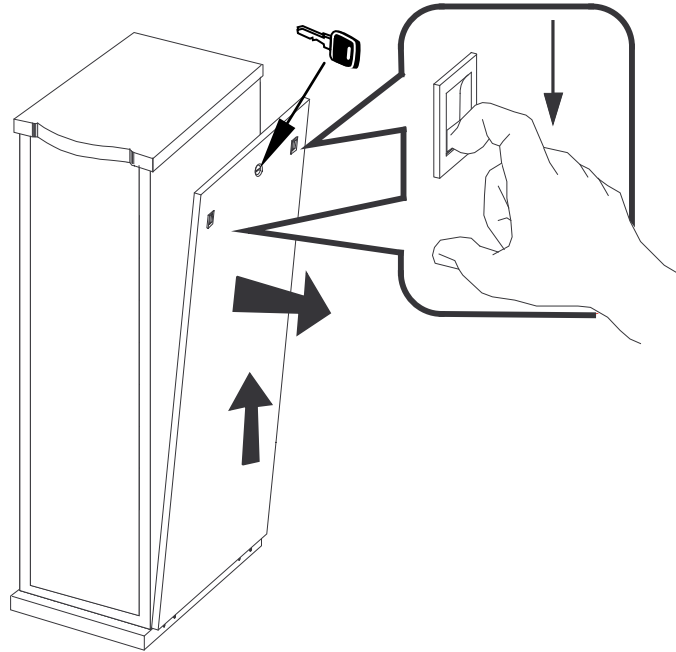

3. Install the solid side panel on the modular battery cabinet.
4. Remove the needed knockouts on the side panel with knockouts and install the cable routing hardware (chase nipple, locking nut and cable bushing) and install it on the UPS cabinet.
5. Remove the side panels on the other modular battery cabinets, remove the needed knockouts, install the cable routing hardware and reinstall the side panels. Use the stabilizing feet to adjust for aligning the cabinets, if necessary

Communication cables and battery cables can now be routed through the knockouts in the modular battery cabinets.

Prepare for Cables in a Bottom Cable Entry System

1. Loosen the screws to remove the plate.

2. Punch holes as required and reinstall the plate before mounting the wiring hardware.

Rear View

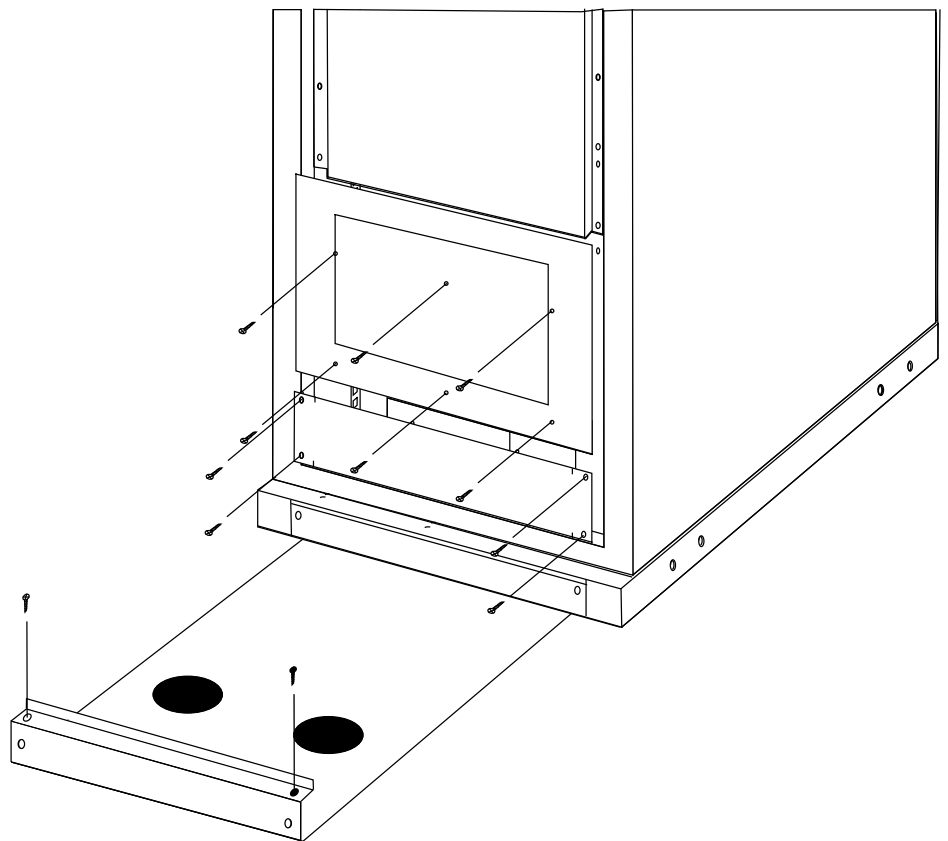

Prepare for Cables in a Rear Cable Entry System

1. Loosen the screws to remove the plate.

2. Punch holes as required and reinstall the plate before mounting the wiring hardware.

Rear View of UPS

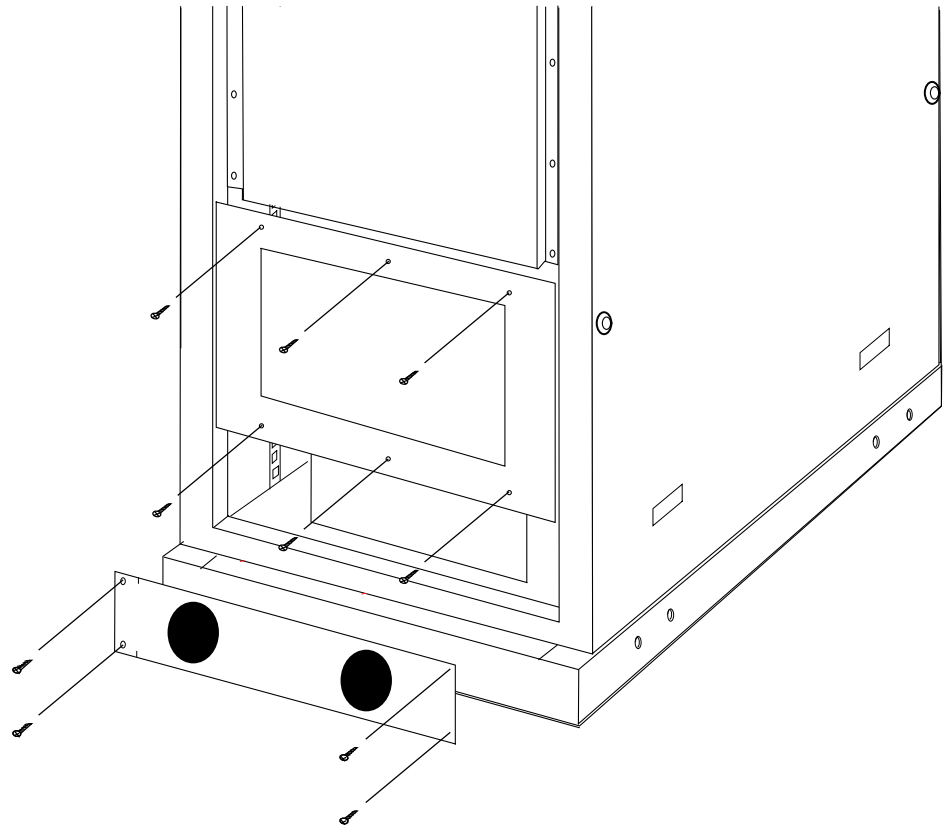

Connect the Input Power Cables

⚠ DANGER

HAZARD OF ELECTRICAL SHOCK, EXPLOSION, OR ARC FLASH

A 90 A circuit breaker with a shunt trip must be installed to protect the system against over-current from the utility source.

Failure to follow these instructions will result in death or serious injury.

1. Install a 90 A input utility circuit breaker with a shunt trip upstream of the UPS.
2.
 - **Top access system:** Remove the main input gland plate by loosening the screws in the roof of the cabinet.

Top Front View of the UPS Cabinet

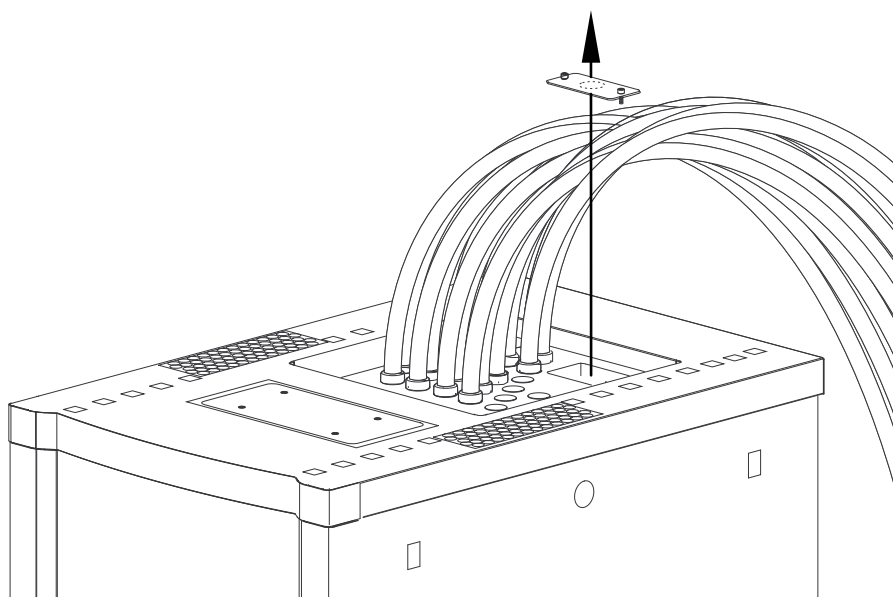

- **Bottom access system:** Remove the floor access cover in the rear of the cabinet and through this remove the input gland plate in the floor of the cabinet.

Bottom Rear View of the UPS Cabinet

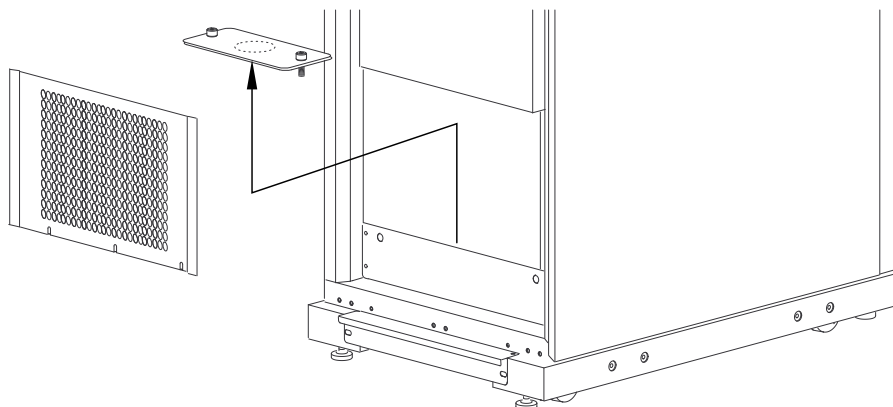

3. Knock out the perforated hole in the gland plate for the conduit.

NOTE: In systems with remote modular battery cabinet(s), drill an extra hole for a conduit for the battery cables in the bottom gland plate.

4. Install a lock-nut and bushing to the conduit.

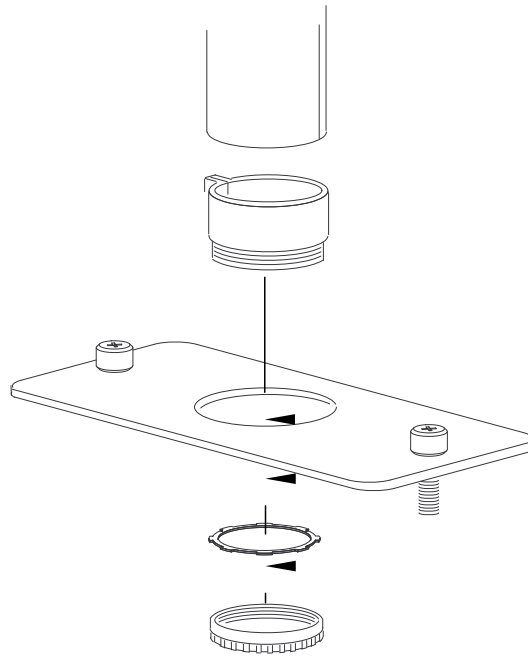

5. Reinstall the input gland plate and thread the conduit through the hole in the gland plate.

6.
 - **Top access system:** Remove the main input access panel to get access to the input terminals.

Top Access – Rear View of the Cabinet

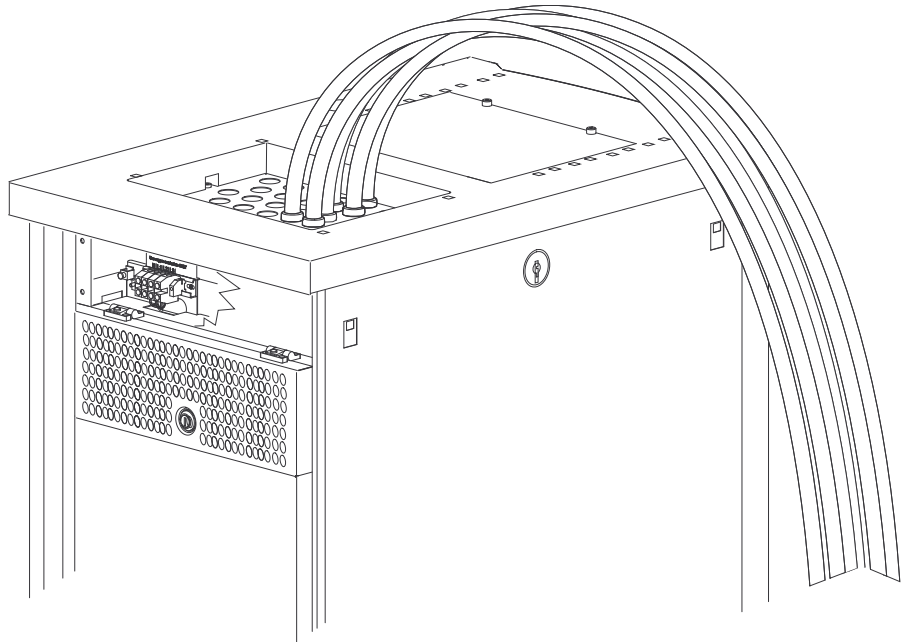

- **Bottom access system:** Access to the bottom input terminals is through the floor access panel (already removed).

Bottom Access – Rear View of the Cabinet

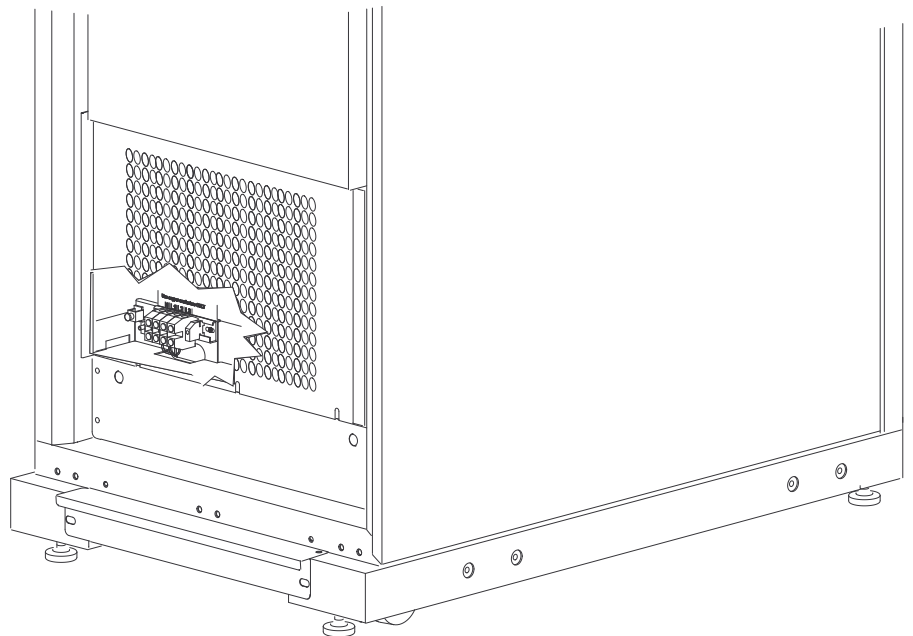

- Run the input cables (L1, L2, L3 and N) and the PE cable from the main utility source through the conduit to the input terminals (top or bottom of the cabinet) and connect the cables according to the labels on the terminals.

Input Terminals – Access in the Top of the Cabinet

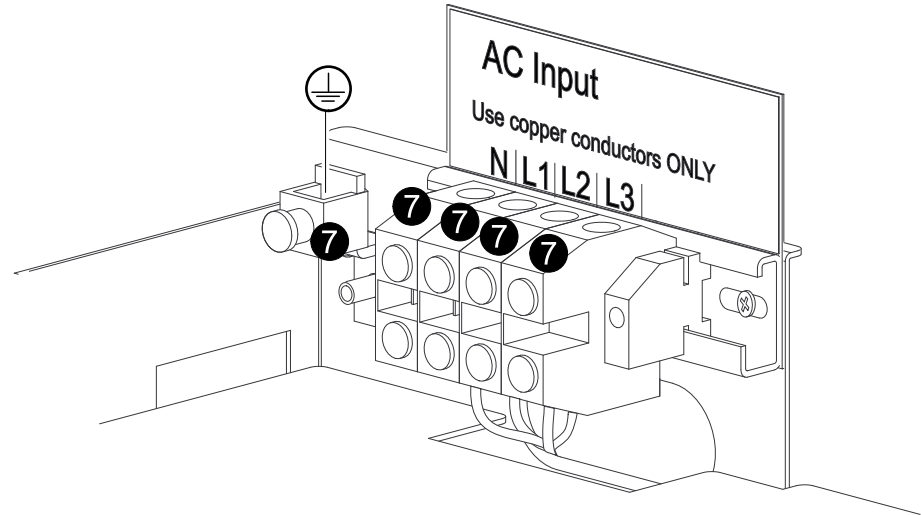

Input Terminals – Access in the Bottom of the Cabinet

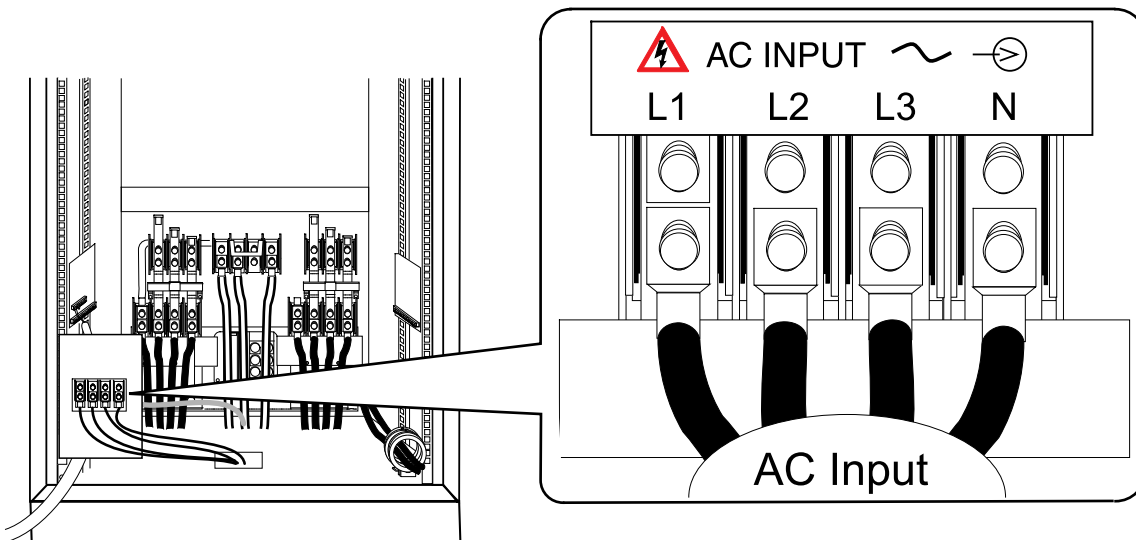

NOTE: Torque L1, L2 and L3 terminal lugs to 24.6–26.1 in-lb and torque the PE lug to 124 in-lb

Connect the Output Power Cables in the PDU

1. Remove the circuit breaker panel cover by loosening the captive screws at each corner of the cover and pull it off.

Rear View of the UPS Cabinet

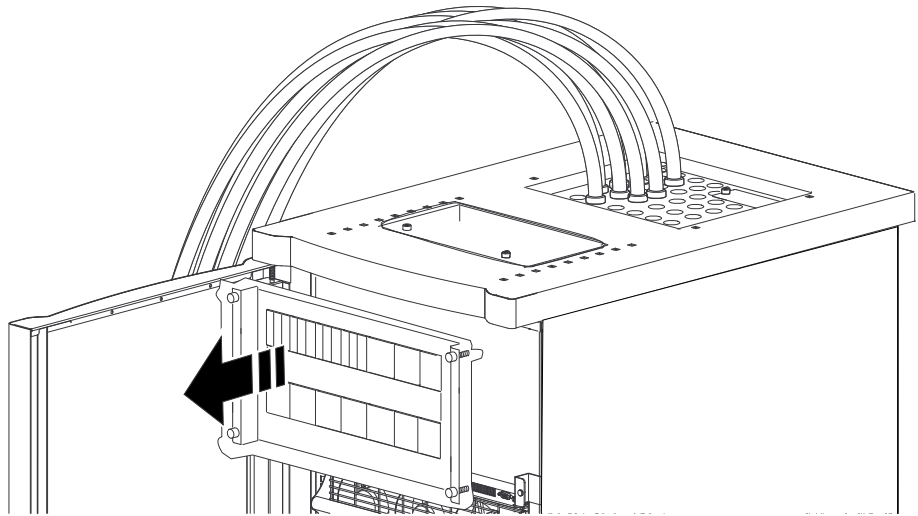

2. On the circuit breaker panel, snap and bolt the breaker into a position on the panel.

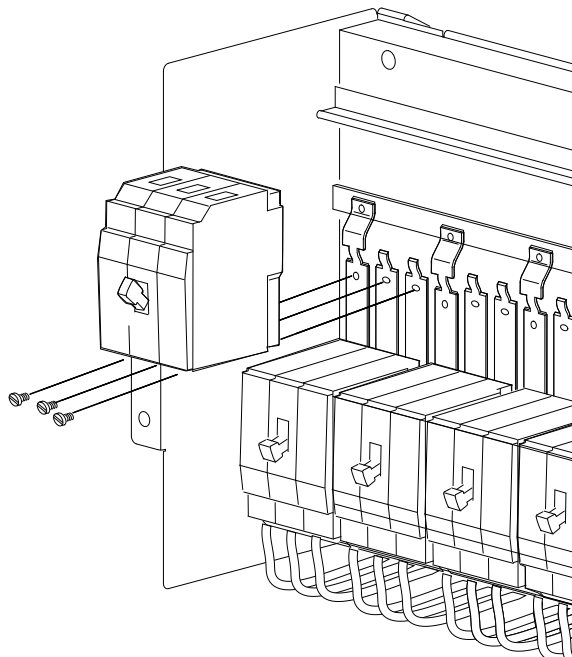

3. Remove the corresponding plastic blanking plate on the panel cover and reattach the panel cover to the cabinet.

4. Remove the wiring access cover on top of the cabinet.

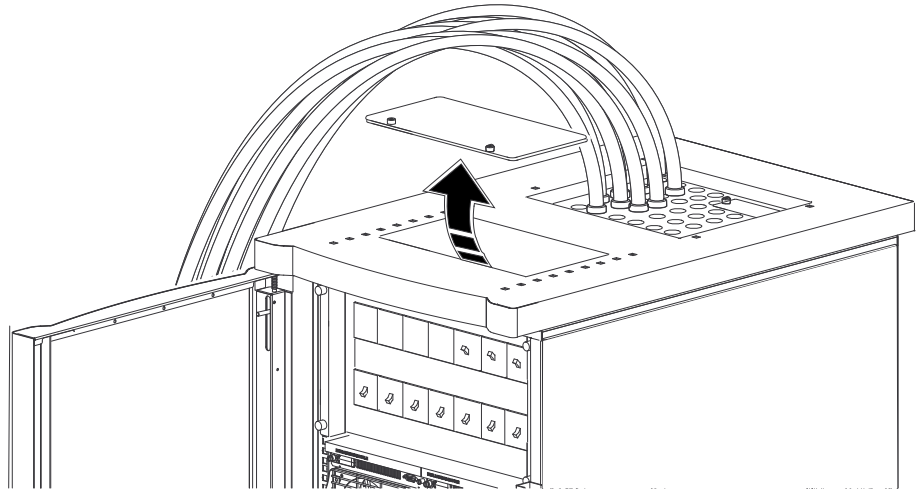

5. Install a strain relief connector in any available knockout on the cabinet roof.

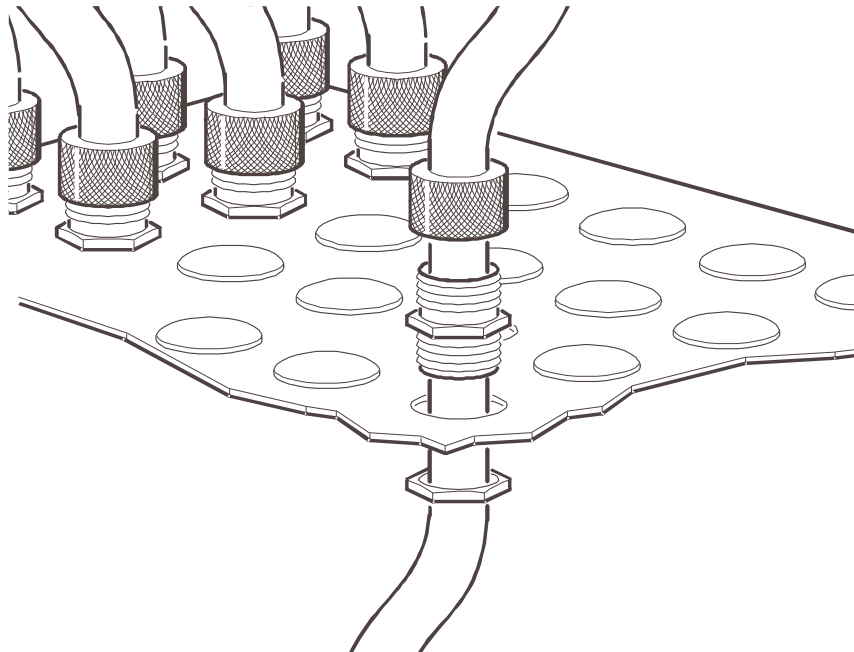

6. Slide enough of the output power cable through the strain relief connector to reach the new circuit breaker.
7. Tighten the strain relief connector
8. Through the wiring access cover there is access to the rear side of the breaker panel. Secure the output power cable here with the wire ties on the back of the breaker panel.
9. Connect the neutral cable to the closest open termination point on the neutral bar.
10. Connect the ground cable to the closest open termination point on the ground bar.

11. Route the output cables (L1, L2, L3) over (shown) or under the rear of the panel.

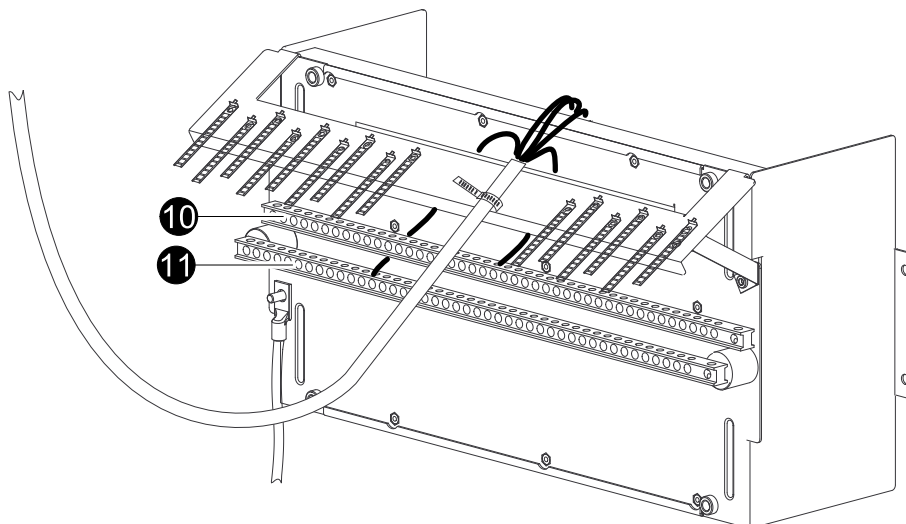

12. At the front of the panel, connect the output cables (L1, L2, L3) to the circuit breaker(s).

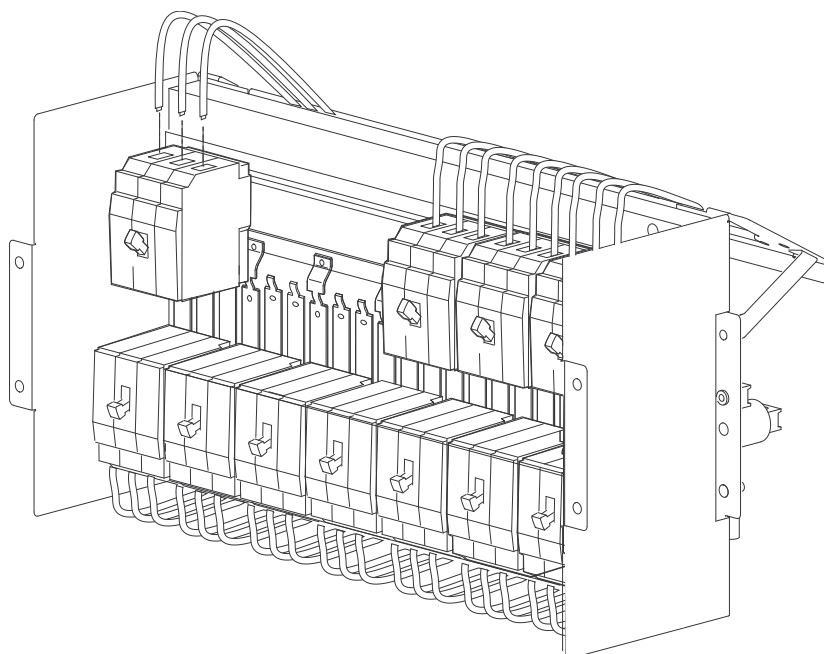

NOTE: In the illustration, three-pole breakers are shown, but single-pole breakers can also be connected.

Connect Battery Cables in the UPS (Option)

NOTE: Up to four modular battery cabinets can be connected to the UPS.

1. Remove the floor access cover in the rear of the cabinet and route the battery cables through the bottom gland plate for remote modular battery cabinet(s) or through the knockout in the UPS side panel for line-up and match modular battery cabinets(s).
2. Connect the battery cables (+, - and CT) to the DC input terminals in the UPS.

Power Terminals

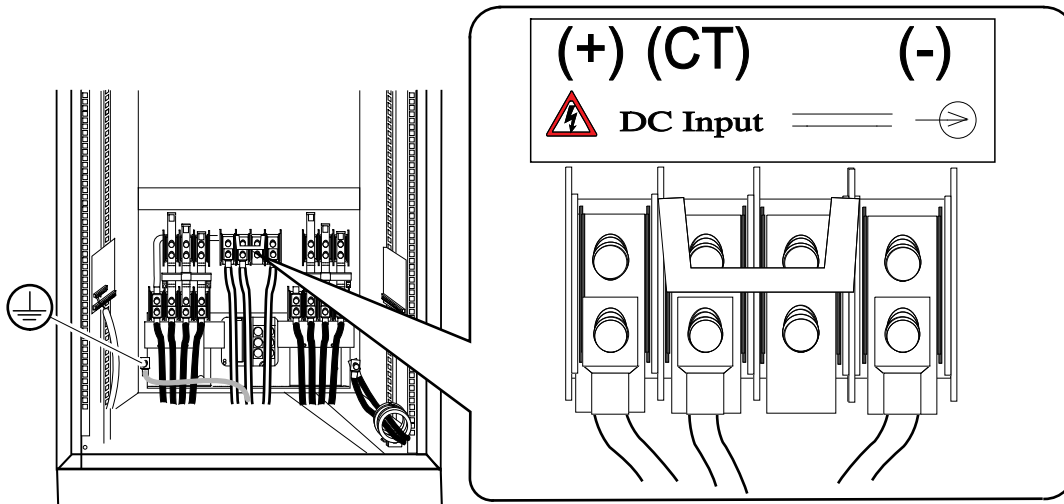

NOTE: Torque L1, L2 and L3 terminal lugs to 24.6–26.1 in-lb and torque the PE lug to 124 in-lb

Connect Emergency Power Off (EPO)

NOTE: EPO wiring: CL2 or other extra-low voltage wiring in accordance with local electrical codes.

NOTE: If you choose to use a 24 VAC, 24 VDC or contact closure connection to the EPO, use one of the following UL-listed wire types:

For installations in the US:

- CL2 Class 2 cable for general purpose use
- CL2P Plenum cable for use in ducts, plenums, and other space used for environmental air
- CL2R Riser cable for use in vertical run shaft from floor to floor
- CL2X Limited Use cable for use in dwellings and raceways

For installation in Canada:

- CSA-certified, type ELC (Extra-Low-Voltage Control Cable)

NOTE: If you do not use a CL2 cable, route the EPO wiring in conduit that does not contain any branch circuit wiring.

1. Route the EPO cable separately from the power cables through a separate conduit through an available cable exit point depending on your installation.

2. Connect a normally open (NO) or a normally closed (NC) EPO switch to the board in the UPS.

Rear View of UPS Cabinet

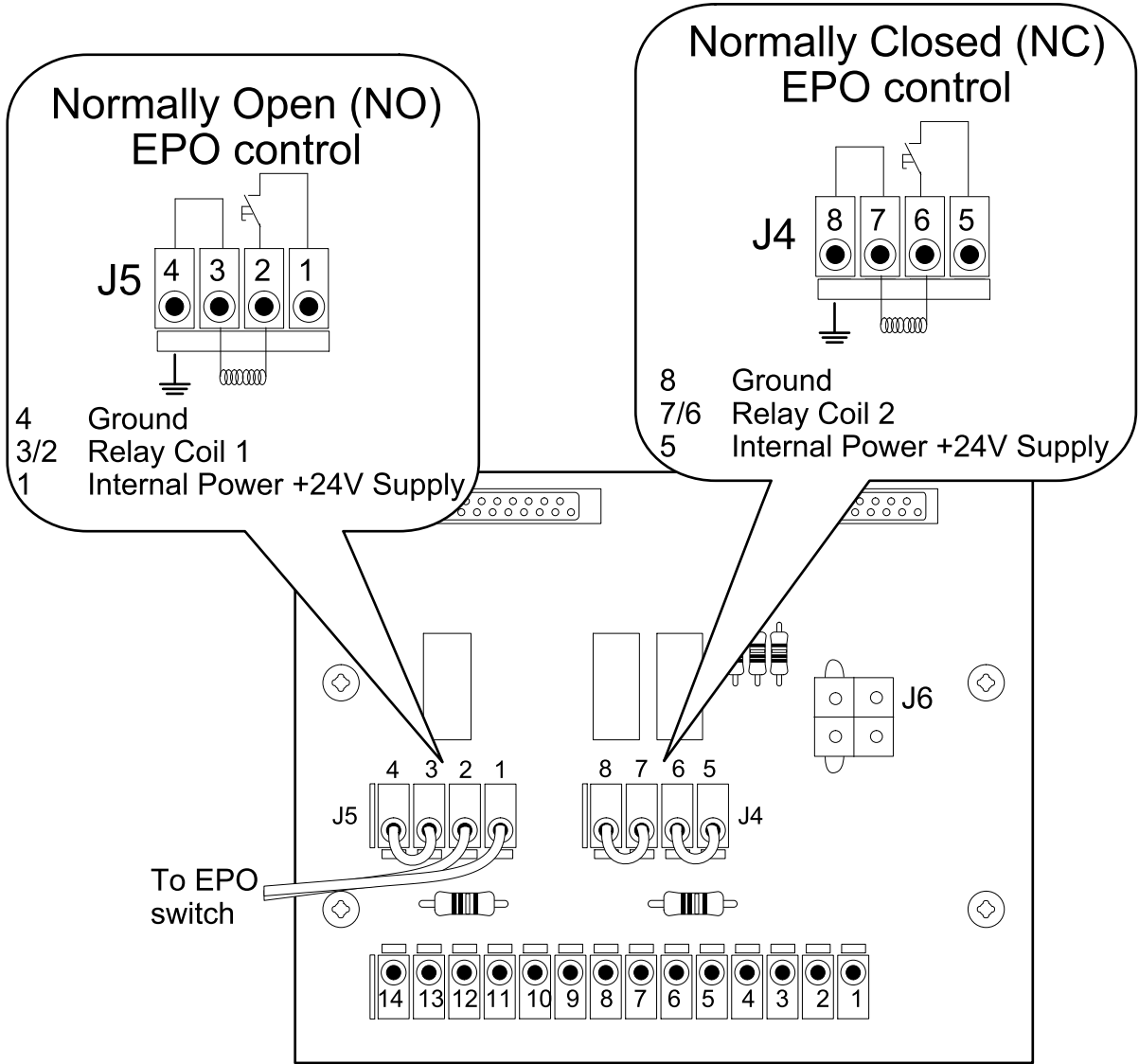
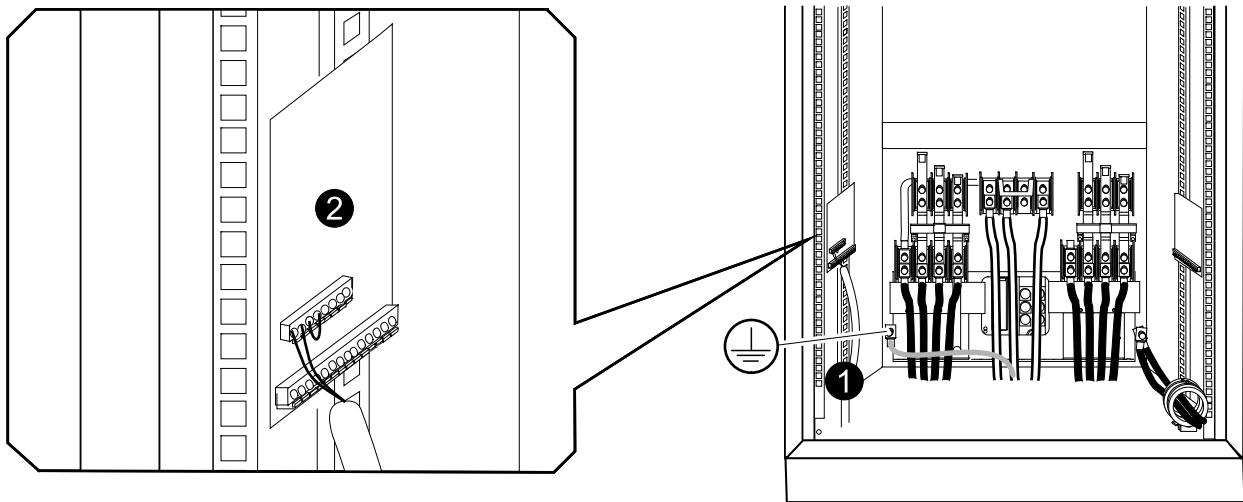

EPO Wiring Options

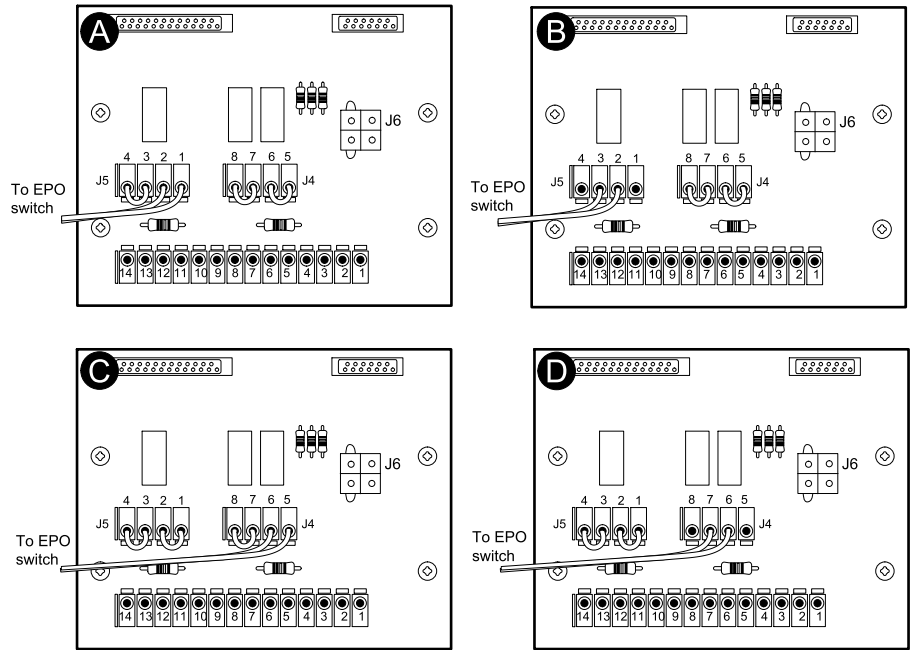

- A. Dry Normally Open contacts
- B. +24V Normally Open (remove jumper)
- C. Dry Normally Closed contacts (remove jumper)
- D. +24V Normally Closed (remove jumper)

Connect Communication Cables

⚠ DANGER

HAZARD OF ELECTRIC SHOCK, EXPLOSION OR ARC FLASH

Ensure total power off before removing the side panel.

Failure to follow these instructions will result in death or serious injury.

NOTE: Use 20-foot standard Cat data cable (supplied). If the cable length is inadequate, a longer Cat 5 cable, or couplers, can be used (not supplied).

NOTE: If bottom cable entry is required, follow steps 1 to 5 below to gain access to the communication cables. If not, proceed to step 6.

Front View of UPS

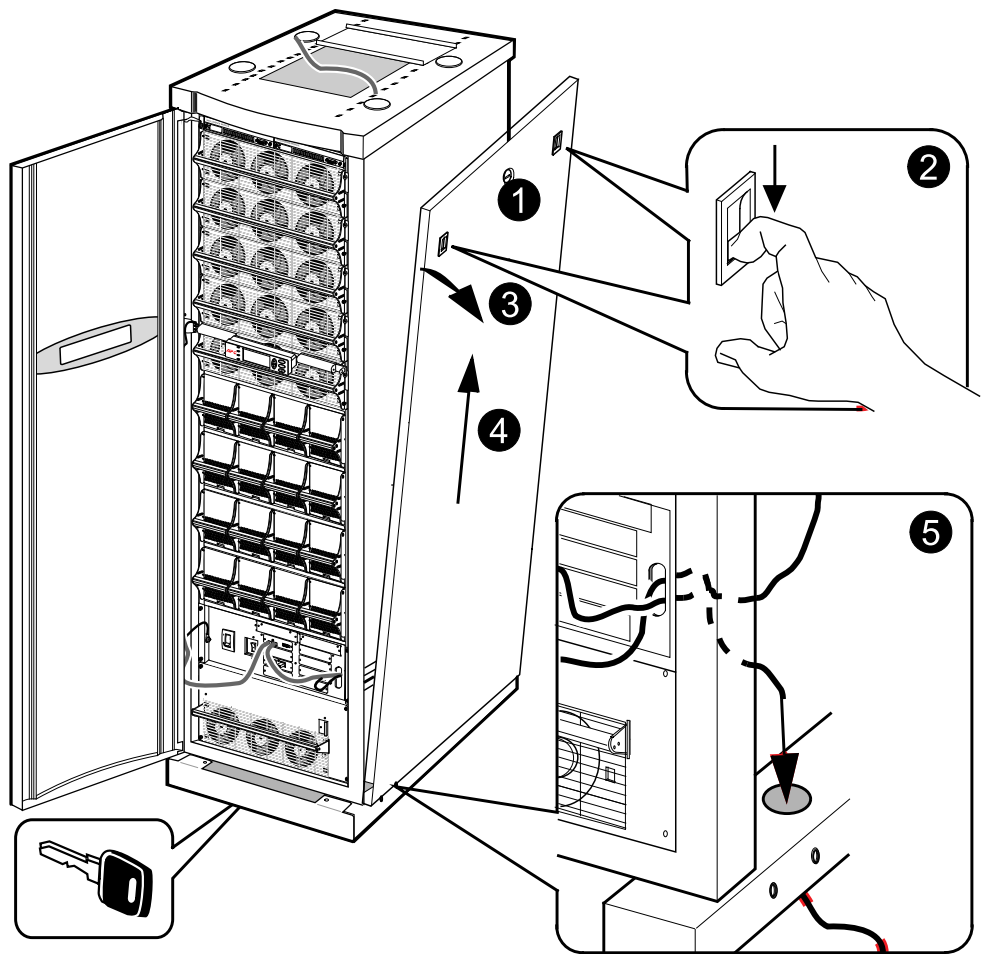

1. Unlock the right-side panel using the key.
2. Depress the latches.
3. Pull out the panel.
4. Lift the panel at an angle away from the cabinet.
5. Route the communication cables through the front holes of the cabinets. Exit the cabinets from the bottom or top as required.

6. Connect the network communication cable.

Front View of UPS

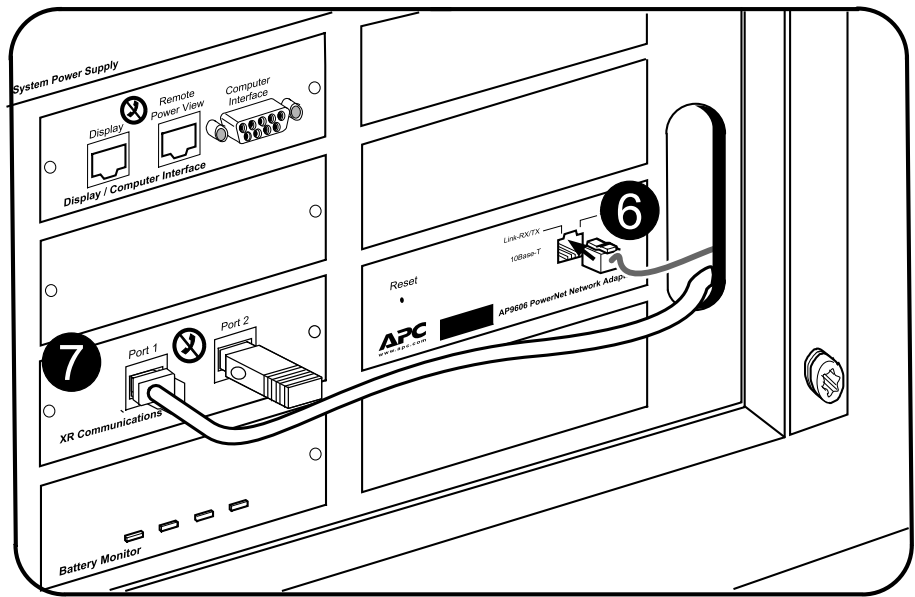

7. **Only in installations with modular battery cabinets:** Route the communication cable from XR Communications port 2 in the first modular battery cabinet to the UPS XR Communications port 1 (for remote modular battery cabinets the length of the signal must not exceed 50 m). The side panel of the modular battery cabinet is removed for cable wiring as in steps 1–5.

Front View of Modular Battery Cabinet

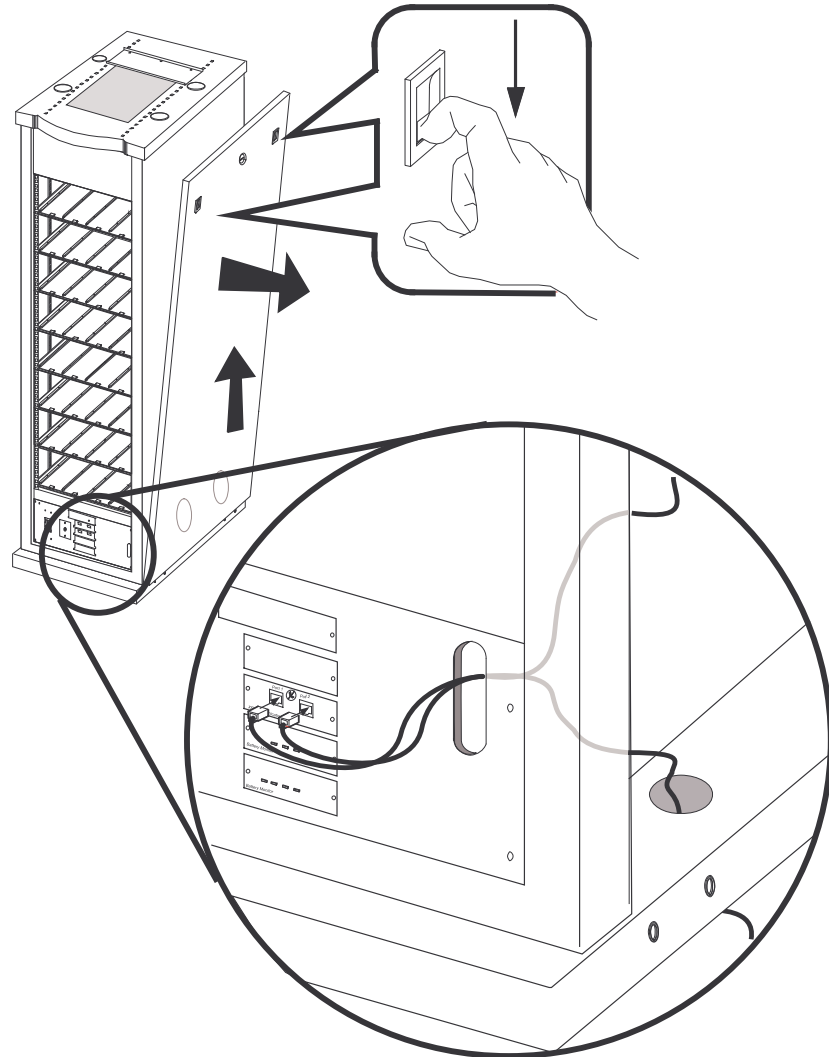

8. **Only in installations with modular battery cabinets:** Route the communication cable from XR Communications port 1 in each modular battery cabinet to XR Communications port 2 in the next modular battery cabinet. Remove the terminator when necessary. Insert the terminator from the cable into the unused communication port on the last modular battery cabinet.
9. Reinstall and lock the side panels on the cabinets after finishing cable routing.

Install Modular Battery Cabinet (Option)

Connect Battery Cables in Modular Battery Cabinet

NOTE: Power terminal lug diameter: 8 mm. Torque power terminal lugs to 53 lb-in (6 Nm).

NOTE: PE and power cables provided with the modular battery cabinet are only for internal cable routing through the side panels — not for cable routing through external conduits.

1. Connect the modular battery cabinet to the PE stud in the UPS cabinet.
2. Connect the battery cables (+, - and CT) from the UPS to the DC output terminals in the modular battery cabinet.

Modular Battery Cabinet

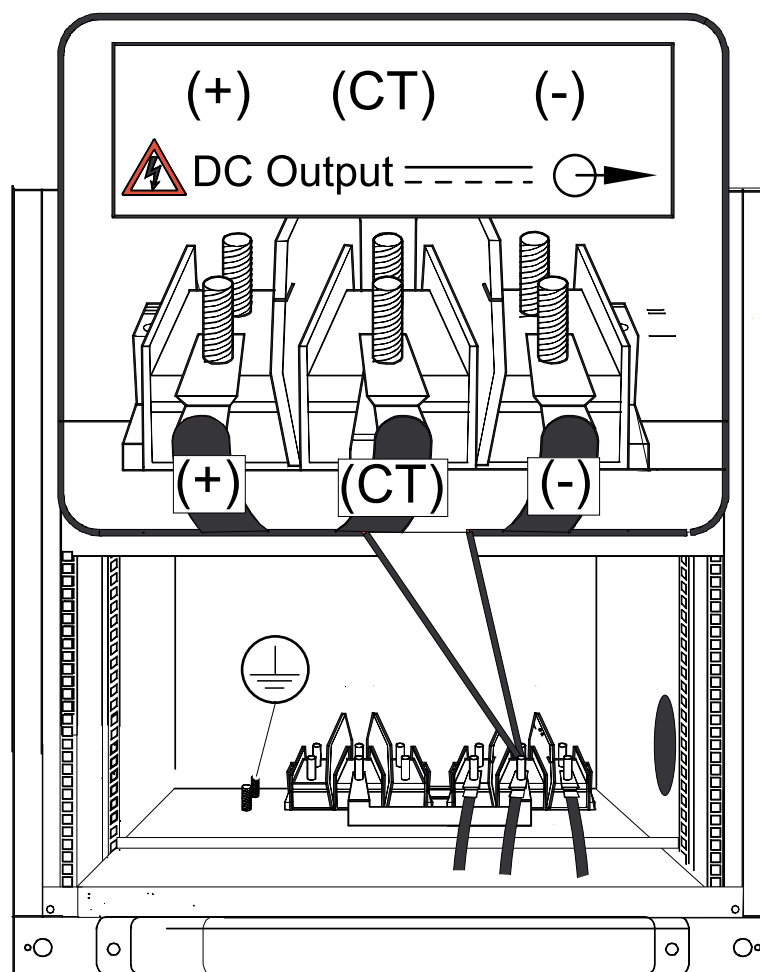

Connect the Battery Cables between the Modular Battery Cabinets

NOTE: For remote modular battery cabinets, the length of the signal and power cables must not exceed 50 m for the cable that connects the modular battery cabinet to the UPS.

1. Connect the battery cables from the DC output terminals in modular battery cabinet 2 to the DC input terminals in modular battery cabinet 1.

Modular Battery Cabinet 1

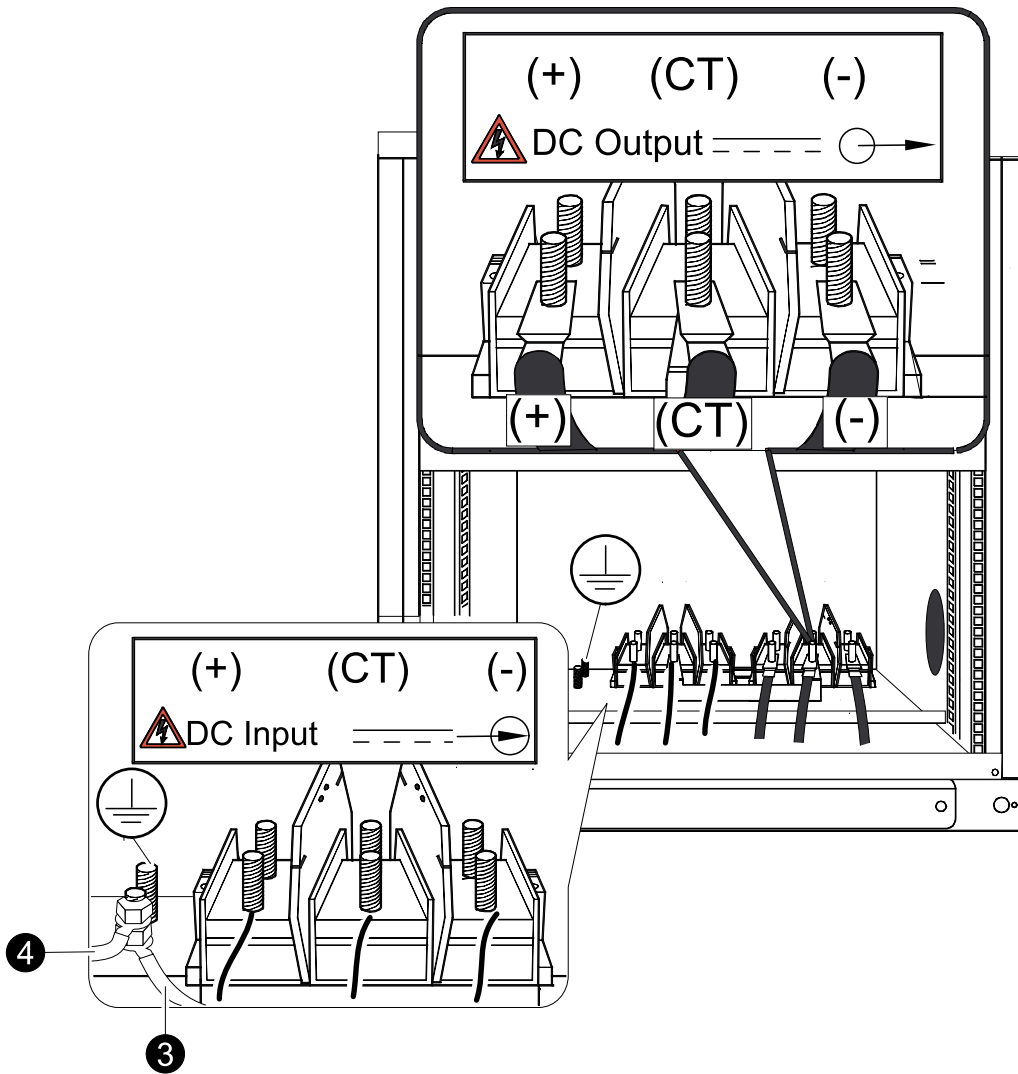

2. Repeat for modular battery cabinet 3 and 4, if applicable.
3. Connect the PE cable from the UPS to the modular battery cabinet (closest to the UPS).

- Route the PE cable from modular battery cabinet to modular battery cabinet through the bottom, rear or side depending on chosen cable entry.

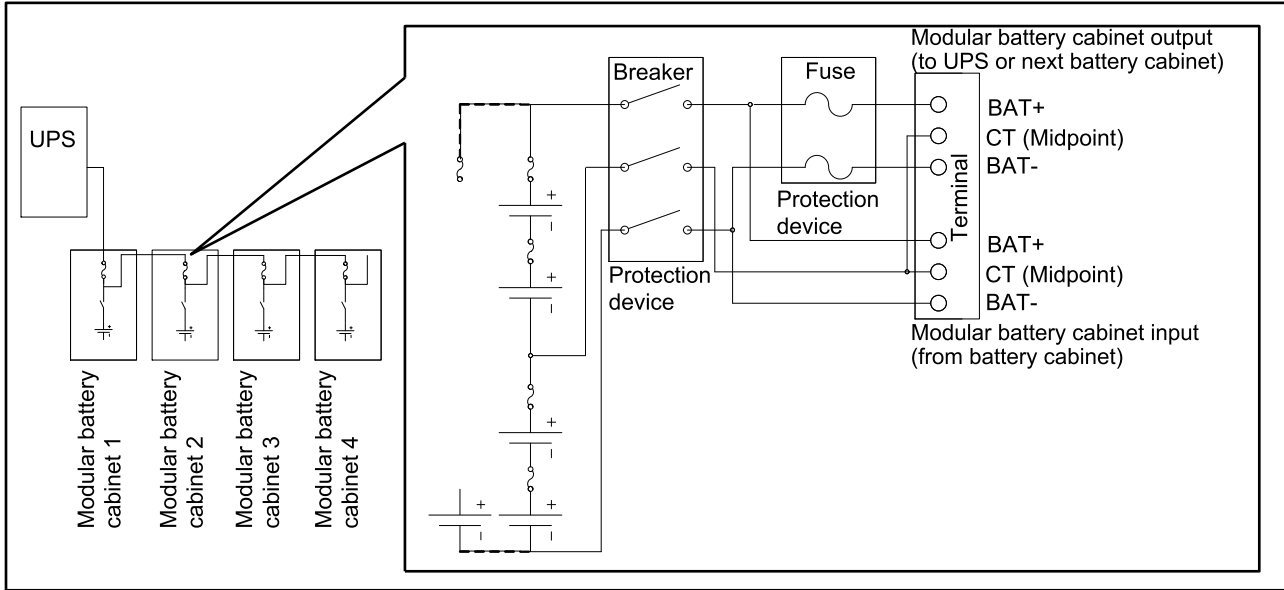

| | |
|----------------|---|
| Fuse rating | 125 A Class J |
| Breaker rating | 320 A with thermal and magnetic trip-unit |

- Place the cabinet address on the front of each modular battery cabinet (**1** for modular battery cabinet 1, **2** for modular battery cabinet number 2 etc.).

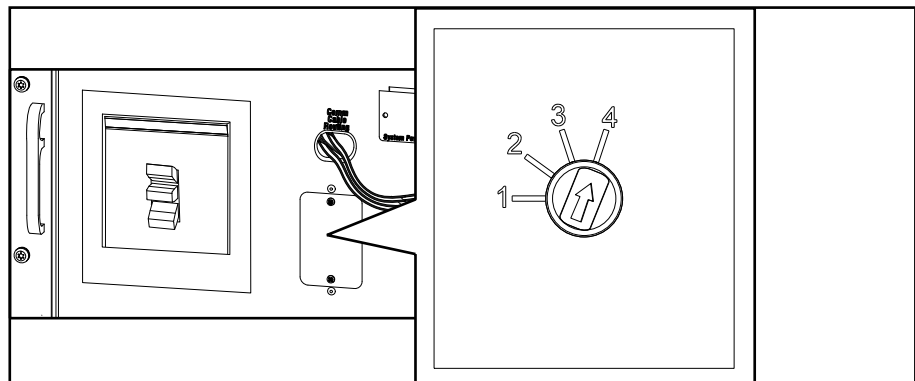

Schneider Electric
35 rue Joseph Monier
92500 Rueil Malmaison
France

+ 33 (0) 1 41 29 70 00

www.schneider-electric.com

As standards, specifications, and design change from time to time,
please ask for confirmation of the information given in this publication.

© 2014 – 2016 Schneider Electric. All rights reserved.

990-1493D-001