

Installation Manual

150 kVA Power Distribution Unit

PDPB150G6F

990-5235A-001

Publication Date: April 2015

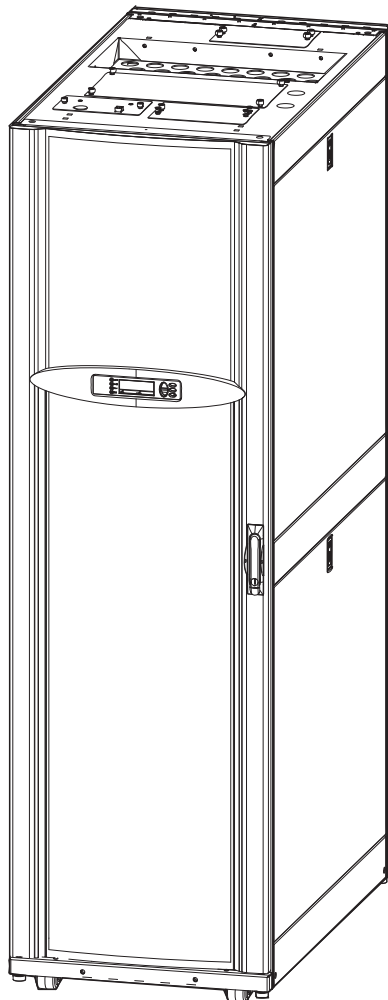

Schneider Electric IT Corporation Legal Disclaimer

The information presented in this manual is not warranted by the Schneider Electric IT Corporation to be authoritative, error free, or complete. This publication is not meant to be a substitute for a detailed operational and site specific development plan. Therefore, Schneider Electric IT Corporation assumes no liability for damages, violations of codes, improper installation, system failures, or any other problems that could arise based on the use of this Publication.

The information contained in this Publication is provided as is and has been prepared solely for the purpose of evaluating data center design and construction. This Publication has been compiled in good faith by Schneider Electric IT Corporation. However, no representation is made or warranty given, either express or implied, as to the completeness or accuracy of the information this Publication contains.

IN NO EVENT SHALL SCHNEIDER ELECTRIC IT CORPORATION, OR ANY PARENT, AFFILIATE OR SUBSIDIARY COMPANY OF SCHNEIDER ELECTRIC IT CORPORATION OR THEIR RESPECTIVE OFFICERS, DIRECTORS, OR EMPLOYEES BE LIABLE FOR ANY DIRECT, INDIRECT, CONSEQUENTIAL, PUNITIVE, SPECIAL, OR INCIDENTAL DAMAGES (INCLUDING, WITHOUT LIMITATION, DAMAGES FOR LOSS OF BUSINESS, CONTRACT, REVENUE, DATA, INFORMATION, OR BUSINESS INTERRUPTION) RESULTING FROM, ARISING OUT, OR IN CONNECTION WITH THE USE OF, OR INABILITY TO USE THIS PUBLICATION OR THE CONTENT, EVEN IF SCHNEIDER ELECTRIC IT CORPORATION HAS BEEN EXPRESSLY ADVISED OF THE POSSIBILITY OF SUCH DAMAGES. SCHNEIDER ELECTRIC IT CORPORATION RESERVES THE RIGHT TO MAKE CHANGES OR UPDATES WITH RESPECT TO OR IN THE CONTENT OF THE PUBLICATION OR THE FORMAT THEREOF AT ANY TIME WITHOUT NOTICE.

Copyright, intellectual, and all other proprietary rights in the content (including but not limited to software, audio, video, text, and photographs) rests with Schneider Electric It Corporation or its licensors. All rights in the content not expressly granted herein are reserved. No rights of any kind are licensed or assigned or shall otherwise pass to persons accessing this information.

This Publication shall not be for resale in whole or in part.

Contents

- Overview 1
 - Important Safety Information. 1
 - Additional Safety Information 2
 - Before you begin 2
 - Operation and Adjustments 2

- About This Manual 3
 - Related Documents. 3
 - Product Related Information 3
 - User Comments 3
 - Component Identification 4
 - Exterior components 4
 - Interior components 5

- Installation 6
 - Electrical Safety 6
 - SAVE THESE INSTRUCTIONS! 6
 - Space Considerations 6
 - Row Installation. 7
 - Remove and install the side panels 7
 - Maintenance Bypass Panel Interface 8
 - Important information regarding derated units 9
 - Connect the Maintenance Bypass Panel to the PDU 9
 - Perform Equipotential Bonding 10
 - Connect and Level Enclosures 11
 - Prepare for Power Cables. 12
 - Top or bottom cable entry 12

Main installation	13
Connect the subfeed breaker	14
Shunt Trip Installation	16
Tools Required (not provided)	16
Output cables rating	16
Installation	16
User Input/Output Contacts	20
Network Communication Cable	21
Modbus Connection	21
Optional Equipment	22
Seismic Stability Kit	22
Seismic side panel locks	22
Floor brackets	25
Install front anchoring bracket	26
Roof stability brackets	27
Shielding Troughs	27
Post-Installation Checklist	28
Specifications	29
Full load heat loss at nominal main	30
Recommended Conductor Sizes per Phase	30
480VAC Standard rated (80%) 100% rated	30

Overview

Important Safety Information

Read the instructions carefully and look at the equipment to become familiar with the device before trying to install, operate, service or maintain it. The following special messages may appear throughout this manual or on the equipment to warn of potential hazards or to call attention to information that clarifies or simplifies a procedure.



The addition of this symbol to a Danger or Warning safety label indicates that an electrical hazard exists which will result in personal injury if the instructions are not followed.



This is the safety alert symbol. It is used to alert you to potential personal injury hazards. Obey all safety messages that follow this symbol to avoid possible injury or death.

⚠ DANGER

DANGER indicates an imminently hazardous situation which, if not avoided, **will result in death** or serious injury.

⚠ WARNING

WARNING indicates a potentially hazardous situation which, if not avoided, **can result in death** or serious injury.

⚠ CAUTION

CAUTION indicates a potentially hazardous situation which, if not avoided, **can result in minor** or moderate injury.

NOTICE

NOTICE addresses practices not related to physical injury including certain environmental hazards, potential equipment damage or loss of data.

Additional Safety Information

Before you begin

Verify that the system is free from all short circuits and grounds, except those grounds installed according to local regulations (according to the National Electrical Code in the U.S.A., for instance). If high-potential voltage testing is necessary, follow recommendations in equipment documentation to prevent accidental equipment damage.

Before energizing equipment:

- Remove tools, meters, and debris from equipment.
- Close the equipment enclosure doors.
- Remove ground from incoming power lines.
- Perform all start-up tests recommended by the manufacturer.

Operation and Adjustments

The following precautions are from the NEMA Standards Publication ICS 7.1-195 (English version prevails):

- Regardless of the care exercised in the design and manufacture of equipment or in the selection and ratings of components, there are hazards that can be encountered if such equipment is improperly operated.
- It is sometimes possible to misadjust the equipment and thus produce unsatisfactory or unsafe operation. Always use the manufacturer's instructions as a guide for functional adjustments. Personnel who have access to these adjustments should be familiar with the equipment manufacturer's instructions and the machinery used with the electrical equipment.
- Only those operational adjustments actually required by the operator should be accessible to the operator. Access to other controls should be restricted to prevent unauthorized changes in operating characteristics.

⚠ WARNING
UNGUARDED MACHINERY HAZARD <ul style="list-style-type: none">• Do not use this product with equipment which does not have point-of-operation protection.• Do not reach into equipment during operation. Failure to follow these instructions can result in death, serious injury, or equipment damage.

About This Manual

This manual is intended for users of the specified Schneider Electric equipment. It contains important safety warnings and instructions, gives an introduction to the display interface and provides detailed information for proper use of the equipment.

Related Documents

Download technical publications and other technical information or look for updates to your manual at www.schneider-electric.com.

Product Related Information

<p style="text-align: center;">⚡ ⚠ DANGER</p> <p>HAZARD OF ELECTRIC SHOCK, EXPLOSION, OR ARC FLASH</p> <p>Turn off all power supplying this equipment before working on the equipment.</p> <p>Failure to follow these instructions will result in death or serious injury.</p>

User Comments

Contact www.schneider-electric.com/support/. We welcome your comments about this document.

Component Identification

Exterior components

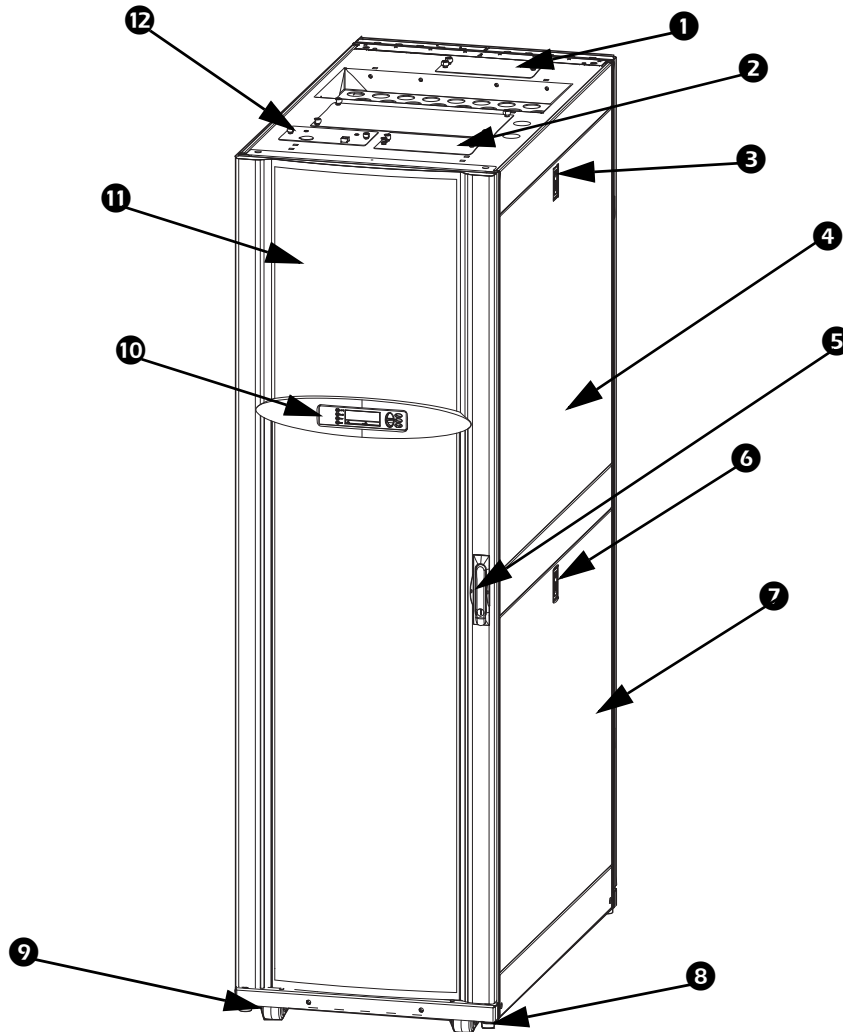

Item	Description
①	Subfeed electrical plate
②	Incoming power cover plate
③	Locking latch for upper side panel
④	Upper side panel
⑤	Front door locking handle
⑥	Locking latch for lower side panel
⑦	Lower side panel
⑧	Leveling foot
⑨	Caster
⑩	Display interface
⑪	Front door
⑫	Communication port/interface plate

Interior components

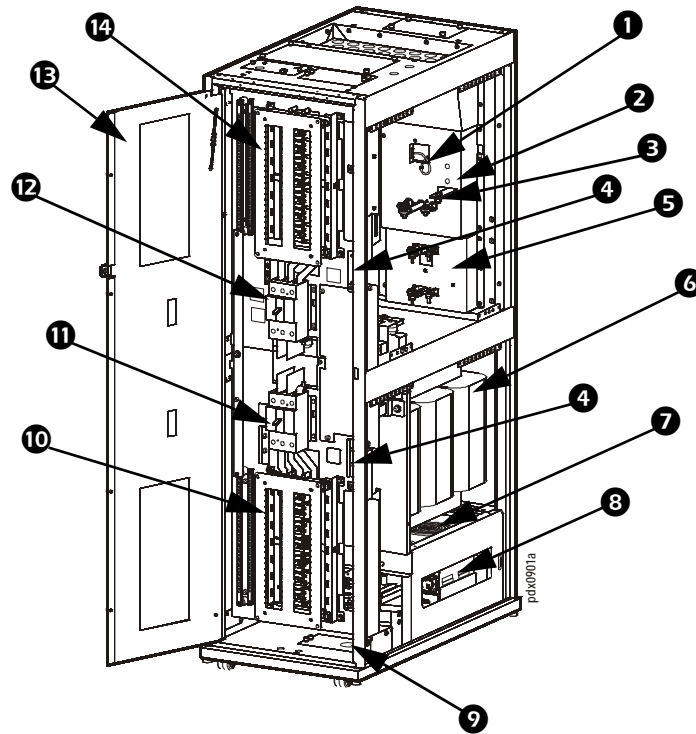

Item	Description
①	Subfeed Aux Switch Signal Cable
②	Subfeed Circuit Breaker
③	Busbar, (Subfeed, Neutral)
④	Branch Circuit Monitoring Daughter board (optional)
⑤	Main Input Breaker
⑥	Transformer
⑦	Fan Tray
⑧	Circuit Card Drawer
⑨	Incoming Power Cover Plate (Bottom feed)
⑩	Panelboard Cover
⑪	Panel 2 Breaker
⑫	Panel 1 Breaker
⑬	Interior Door
⑭	Panelboard Cover

Installation

Electrical Safety

SAVE THESE INSTRUCTIONS!

⚠ ⚠ DANGER

HAZARD OF ELECTRIC SHOCK

- Electrical equipment must be installed, operated, serviced, and maintained only by qualified personnel.
- Only certified electricians are authorized to connect power to the PDU.
- The PDU must be installed in accordance with the National Electrical Code and all applicable local codes.
- Perform appropriate Lock Out/Tag Out procedures during equipment installation.
- Remove incoming Main power upstream from the PDU before performing any work.
- The PDU does not incorporate a Main disconnect. Live power exists within the equipment when the power is turned off at the input circuit breaker. A disconnect device must be incorporated external to the equipment.
- Service access areas are locked with a Red Key. The Red Keys must remain under the control of qualified service persons.

Failure to follow these instructions will result in death or serious injury.

⚠ CAUTION

UNPROTECTED OUTPUTS

Remove cover plates from the unit before cutting holes for power cable access. Metal shavings can cause serious equipment damage. A metal punch can be used to make the holes in the plates.

Failure to follow these instructions can result in injury or equipment damage.

Space Considerations

Make sure you have enough room to install the unit.

Height - in. (mm)	81 (2057.4)
Width - in. (mm)	24 (609.6)
Depth - in. (mm)	42 (1066.8)
Weight - lb. (kg)	2100 (952.5)

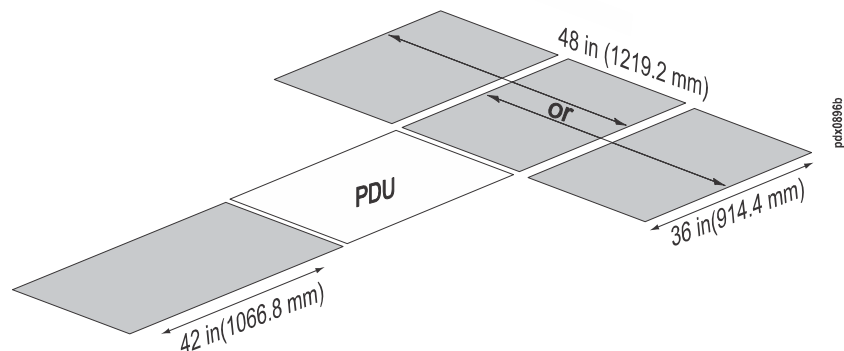

You need at least 42 inches in front of the PDU in order to move the unit in or out of the row. Make sure you have at least 48 inches laterally from either side of the back of the unit to allow for maintenance with the bottom drawer open.

Row Installation

Maintain 36 inch hot aisle spacing.
Transformers are not serviceable, but access is needed to thermal scan transformer connections and to perform other maintenance tasks.

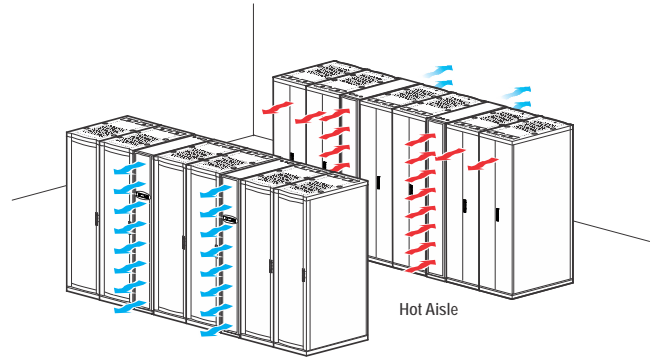

Remove and install the side panels

Two keys are provided. Areas locked with red keys are for service access only. Red keys should not be accessible to other than service personnel.

To remove the side panels, unlock the side panels with the red key (provided). Press down on the lock and then pull out and up.

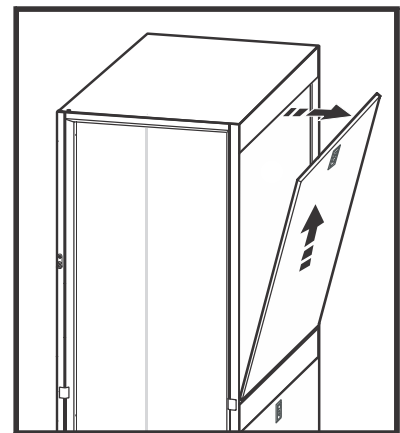

To install the side panels, set the base of the panel at an angle and push the panel in. Lock the side panels with the red key.

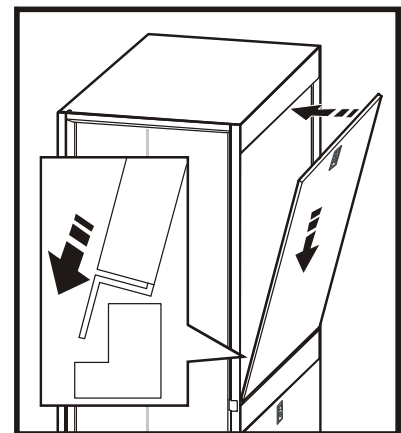

Maintenance Bypass Panel Interface

When the 150kVA PDU is used with a Schneider Electric PX100 UPS, the PDU is derated and set up at the factory for use with a Maintenance Bypass Panel (MBP). See the PX100 UPS manual for more information.

If you will use the 150kVA PDU with the PX100 UPS, your PDU will arrive with the cables to the MBP installed. The cables will be factory installed on either side of the PDU depending on the location of your UPS in relation to the PDU.

There will be no decorative side panel on the side where the cables to the MBP are located, only the interior panel.

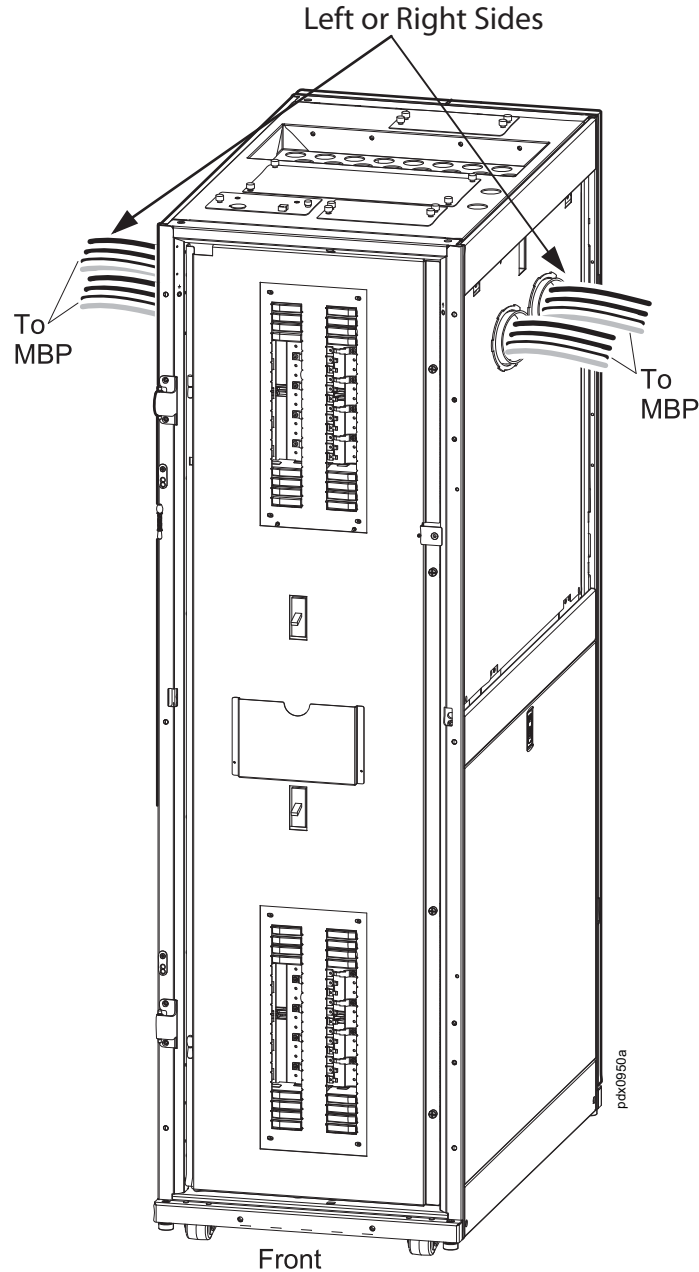

Important information regarding derated units

1. MBP cables are factory configured to either of the two sides of your 150kVA PDU.
2. The 150kVA PDU is derated when used with the Maintenance Bypass Panel (SYMBP100F) and PX100 UPS. Read all the labels on the 150kVA PDU to make sure you do not exceed load ratings.

⚠ WARNING
OVERLOAD HAZARD Adhere to the notification on the main input breaker: 175A, Do Not Adjust. Failure to follow these instructions can result in death, serious injury, or equipment damage.

Derated Specifications:

250A Max Subfeed (SF) Current

278A Max Total (Panel + SF) Current

Look for labels on your unit indicating the PDU has been derated:

	INPUT: 480V~, 3Ø+G+GEC, 60Hz, 165A	This device complies with part 15 of the FCC rules. Operation is subject to the following two conditions: (1) this device may not cause harmful interference, and (2) this device must accept any interference received, including interference that may cause undesired operation.
	OUTPUT TO UPS: 208Y/120V~, 3Ø+N+G, 332A, 60Hz OUTPUT TO LOADS: 208Y/120V~, 3Ø+N+G, 100kVA, 278A, 60Hz	
PDU CONFIGURED FOR USE ONLY WITH MAINTENANCE BYPASS CABINET, MODEL SYMMETRA PX 100 KW MBP & UPS, MODEL SYMMETRA PX 100 KW		885-5960A

Connect the Maintenance Bypass Panel to the PDU

Instructions for connecting the 150kVA PDU to the Symmetra PX 100 UPS through the Maintenance Bypass Panel are available in the Installation Manual for the Symmetra PX 100. View the manual online at www.schneider-electric.com or download the pdf.

Perform Equipotential Bonding

Proper bonding is essential to create an equipotential plane between service grounds and equipment during fault and transient conditions.

Connect the two equipotential bonding conductors between adjacent enclosures in the system. The PDU arrives with the bonding conductors connected. The M8 nuts and washers are supplied in the accessory kit. Move the equipotential bonding wires to your system configuration.

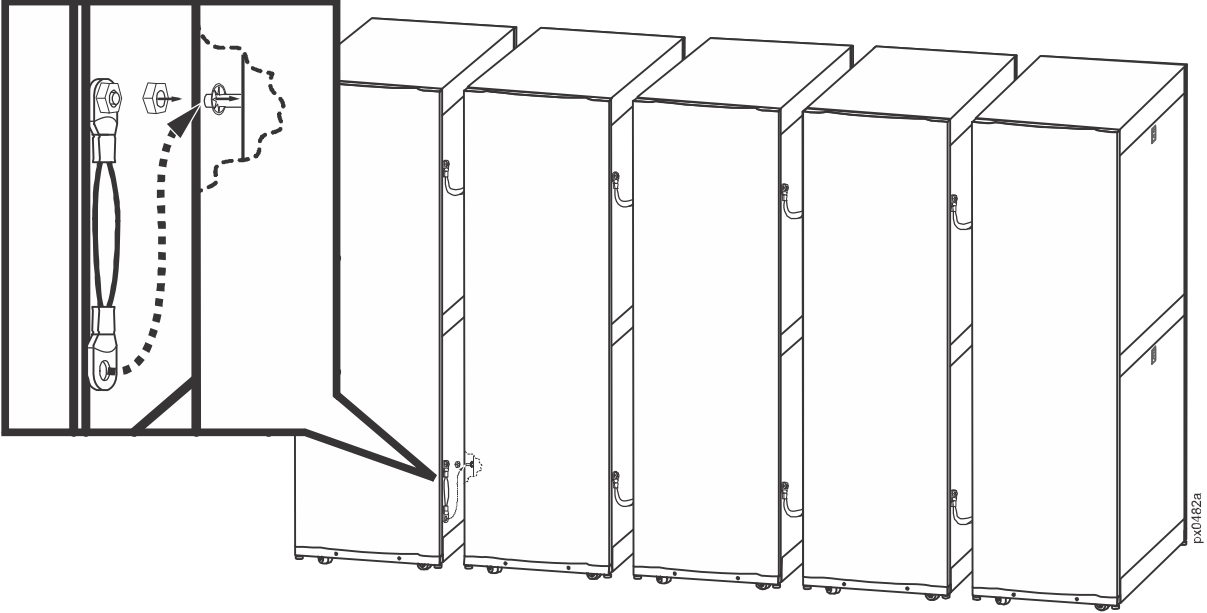

Connect and Level Enclosures

The equipment must be installed on a level floor. The leveling feet will stabilize the enclosure, but will not account for a badly sloped floor.

- 1 Use a screwdriver to lower the four leveling feet.

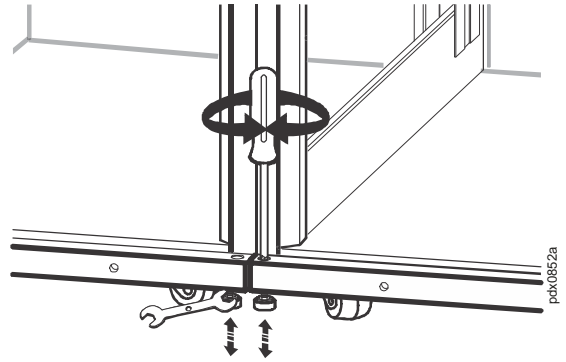

- 2 Use a 13/17 mm wrench to adjust the leveling feet.

Do not move the enclosure after the leveling feet have been lowered.

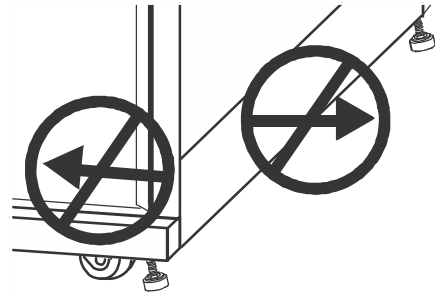

- 3 Align the enclosures.
- 4 Turn the joining brackets and secure with a screw to connect the enclosures.

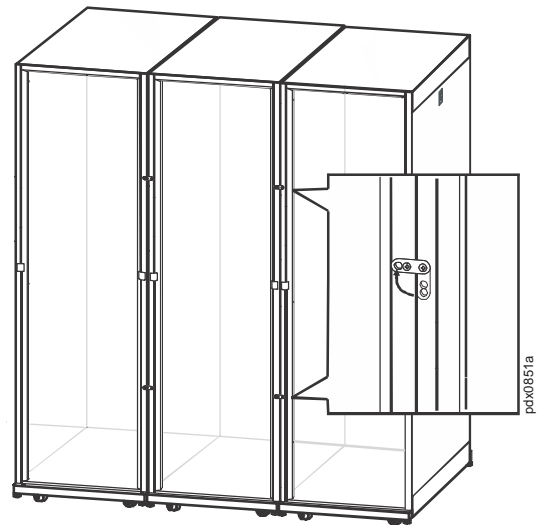

Prepare for Power Cables

Top or bottom cable entry

- 1 Remove the dedicated cover plate.
- 2 Drill or punch holes in the plate for conduits. Install the plate with the conduits mounted.

Top Main and Subfeed Plates

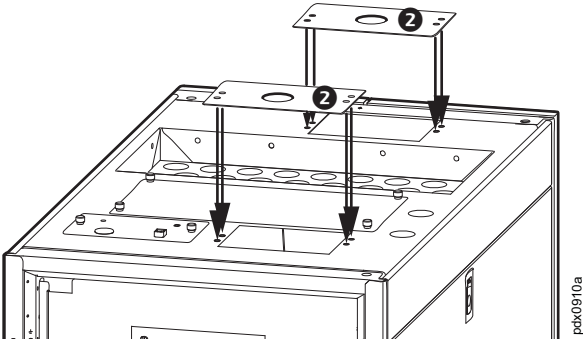
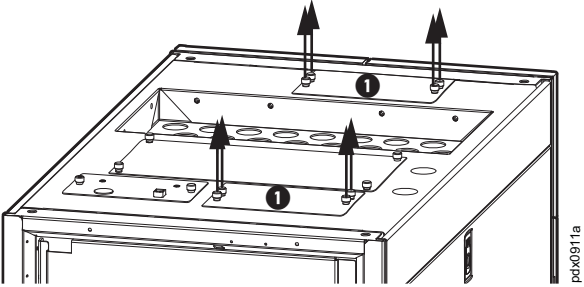

Bottom Main

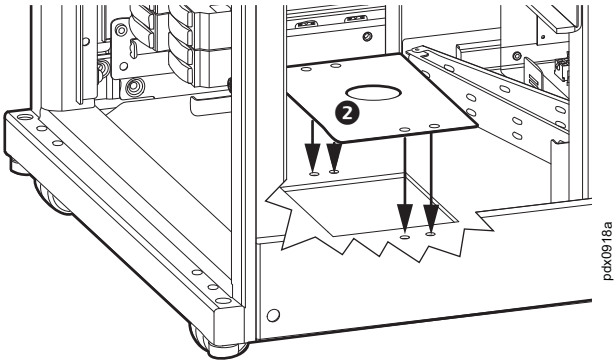
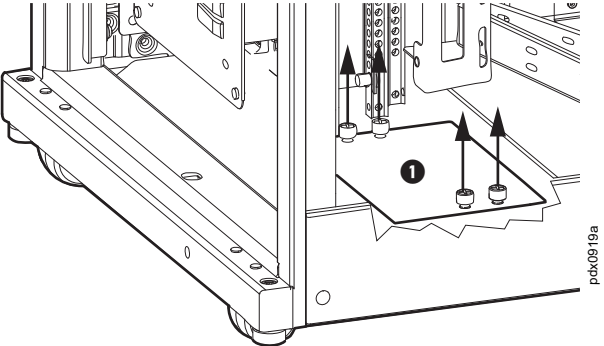

Main installation

- 1 Route the cables from the top or bottom and connect to the Main terminals.
- 2 In bottom entry systems, the Equipment Ground Conductor (EGC) must be reoriented (rotated 90 degrees from its original position) as shown in the illustration. Torque the screw to 5.6 Nm (50 in-lb).
- 3 Connect the phase (L1, L2, L3) cables, and the Grounding Electrode Conductor (GEC) to the terminals. Torque to 62.2 Nm (550 in-lb). Connect the conductor cable to the EGC and torque to 5.6 Nm (50 in-lb).

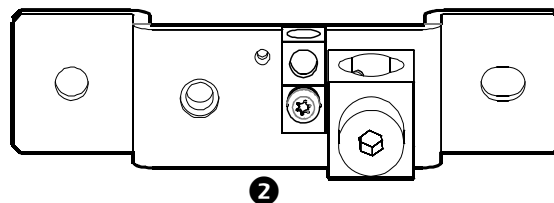
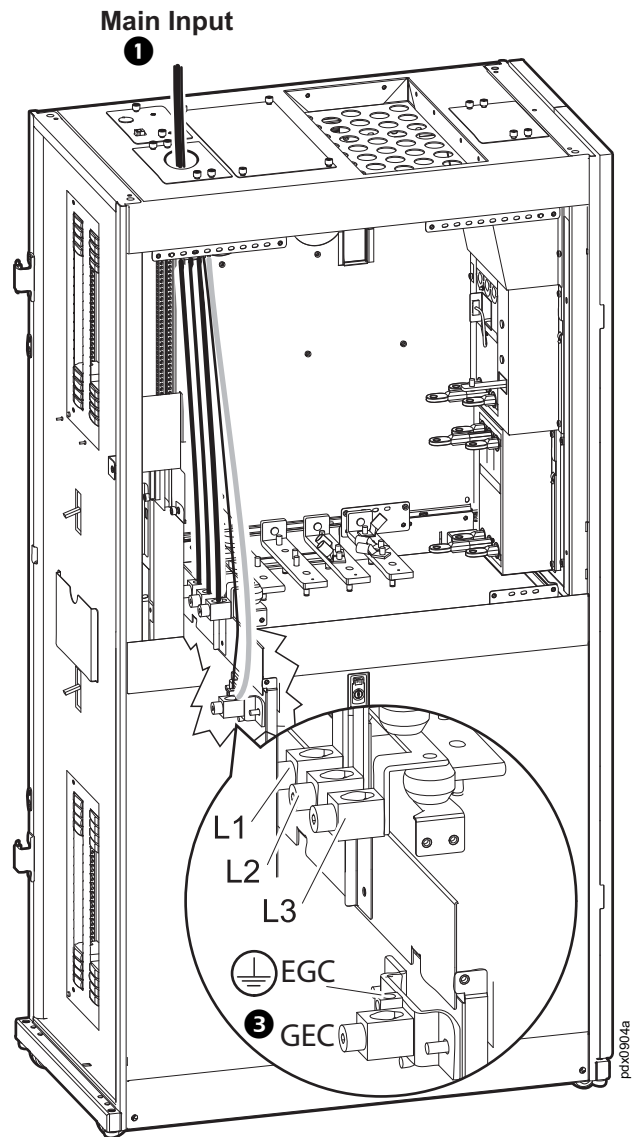

Top Installation

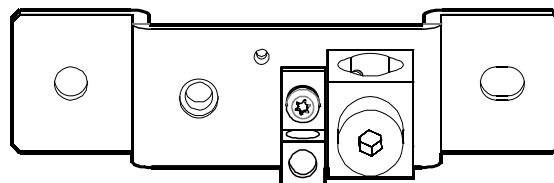

Bottom Installation

Connect the subfeed breaker

NOTICE

Ensure clockwise phase rotation and neutral location of the power terminal bolt.

The following label is found on the PDU. Ensure the torque requirements are met when connecting the subfeed power cables.

LICENSED ELECTRICIAN ACCESS ONLY
Subfeed Electrical Connections

Use Copper or Aluminum Conductors, rated 75°C minimum. Use a 5/16" (8mm) Allen (hex) wrench to tighten the Line and Neutral conductors in the terminals to a torque of 442 lb-in (50 Nm), and 550 lb-in (62.2 Nm), respectively. Use a slotted screwdriver to tighten the Equipment Grounding Conductor in the ground terminal to a torque of 50 lb-in (5.6 Nm). See Installation Instruction for details. Subfeed Max Load 400A, 208Y/120V, 60Hz.

N L1 L2 L3 

885-5731 pdx0972a

If you are using a Maintenance Bypass Panel, the label on your PDU will reflect those requirements. See the Maintenance Bypass section, "Derated Specifications:" on page 9 for more information.

The subfeed breaker is rated for a maximum of 400 A.

- 1 Loosen the thumb screws securing the subfeed cover panel and remove the subfeed cover panel.

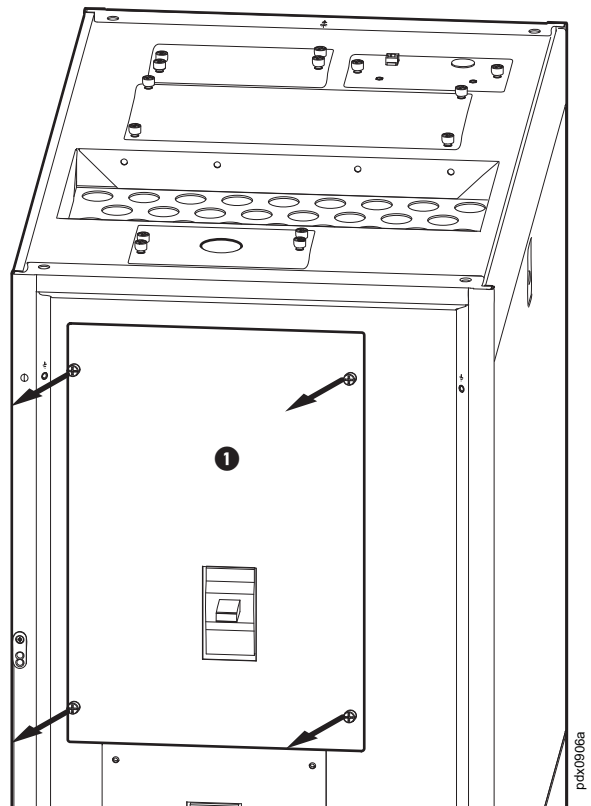

See the table on page 30 for wire size recommendations.

- 2 Connect the output cables to the subfeed breaker. Torque to label specifications.

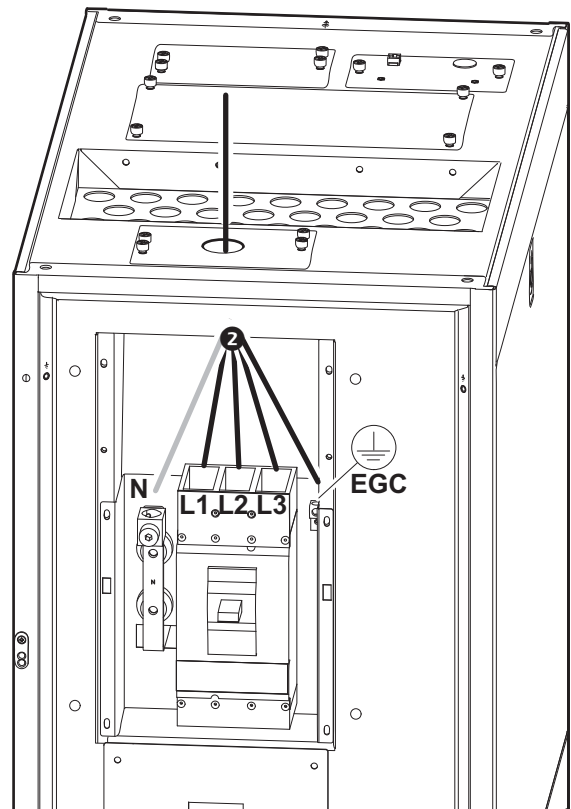

pdx0905a

Shunt Trip Installation

Shunt Trip models for field installation:

- S29384 for 24VAC
- S29382 for 12VAC
- S29390 for 24VDC
- S29391 for 30VDC

⚠ ⚠ DANGER

HAZARD OF ELECTRIC SHOCK, EXPLOSION, OR ARC FLASH

- Electrical equipment must be installed, operated, serviced, and maintained only by qualified personnel.
 - Service access areas are locked with a Red Key. The Red Keys must remain under the control of qualified service personnel.
 - Only qualified electricians may perform this task.
 - Wear appropriate personal protective equipment (PPE) and follow safe electrical work practices. See NFPA 70E.
- Failure to follow these instructions will result in death or serious injury.**

NOTICE

Manufacturer's installation instructions are available inside the Shunt Trip packaging.

Tools Required (not provided)

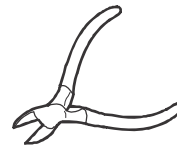
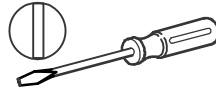

Output cables rating

Use 18 AWG - 14 AWG UL listed wires. Install Class 2 wiring with separation of circuits and wiring in compliance to NFPA/NEC 70. The wires from the Shunt Trip must not exit through the same opening as the power cables. They can exit through any other hole in the roof or a separate hole can be made in the plates to accommodate the Shunt Trip wires.

Installation

- ❶ Shut off all power coming into the PDU.
- ❷ Open the door and interior door or remove the interior panels to access the circuit breaker.

- Press the Red “Push to Trip” button on the circuit breaker.
When the circuit breaker is tripped, the handle will be located in the middle, between the On position and the OFF position.

⚠ CAUTION
HAZARD OF MOVING PARTS
The Circuit Breaker handle snaps to the Tripped position very quickly when the “Push to Trip” button is engaged. To keep the handle from striking your hand, use a long screwdriver to push the button.
Failure to follow these instructions can result in injury.

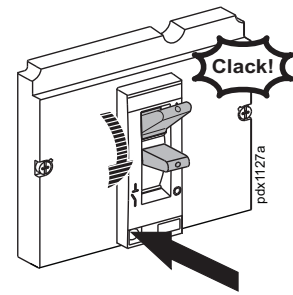

Press Red ‘Push to Trip’ Button

- Remove three screws and the access cover from the circuit breaker.

NOTICE
Some circuit breakers use screws of different lengths to attach the access cover. Observe and make note of the length of the screw removed from each location.

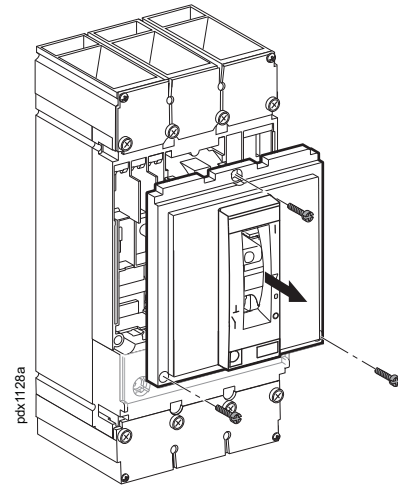

- Press the Shunt Trip into the lower left compartment of the circuit breaker, according to the manufacturer’s instructions.

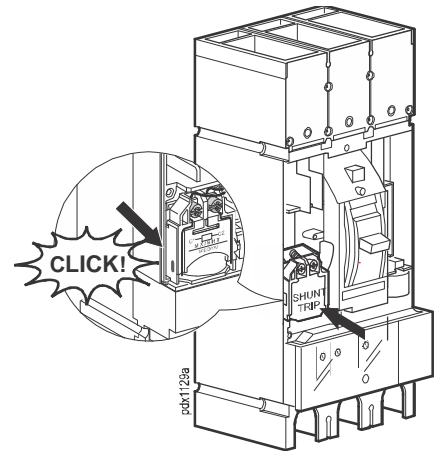

- 6 Use the screwdriver to attach the wires to the Shunt Trip. Tighten the screws. Torque to 12 lb-in (1.4 N•m).

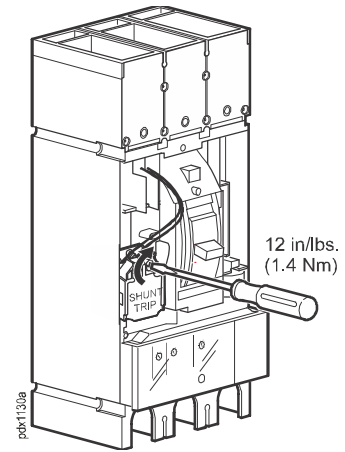

- 7 Route the wires through the circuit breaker. Refer to the instructions included in the Shunt Trip package for more information. Route the wires according to requirements and local regulations.

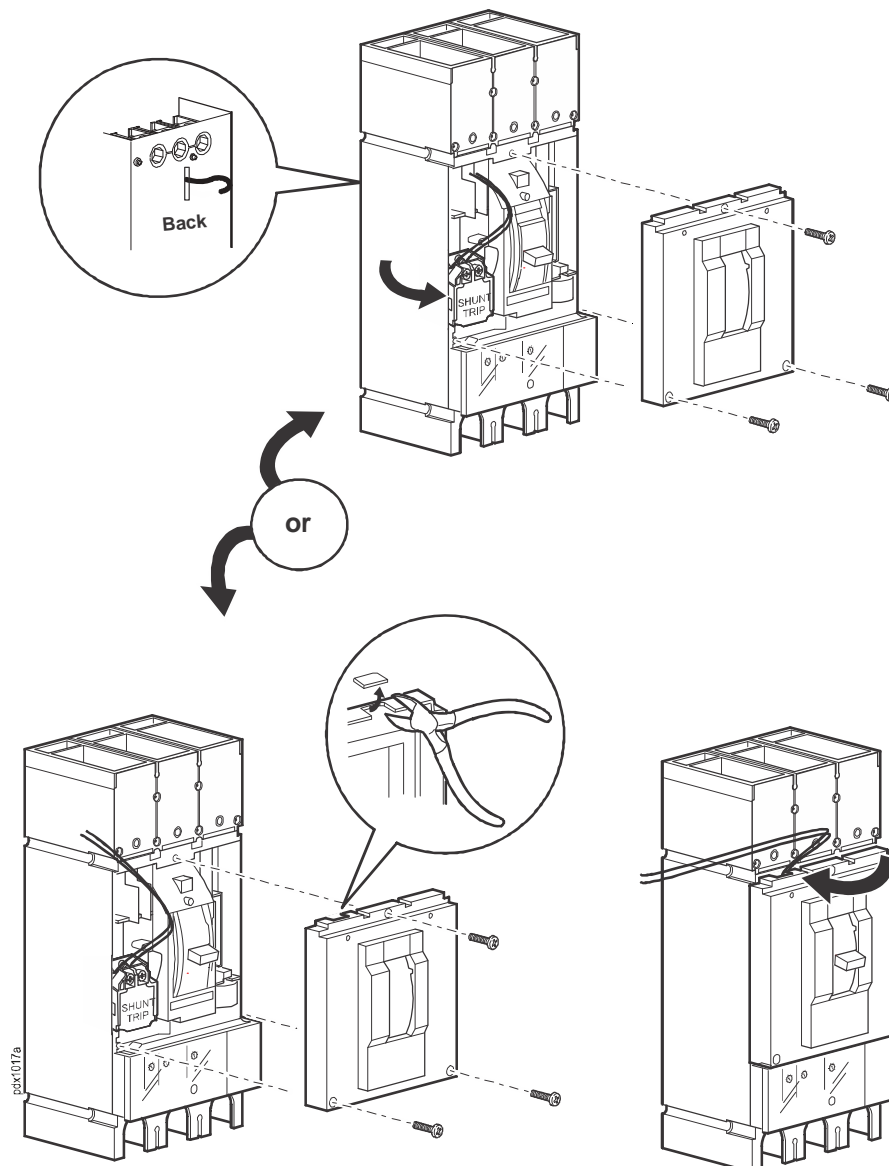

- 8 Replace the circuit breaker access cover. Torque the three screws to 18 lb-in (2 N•m).

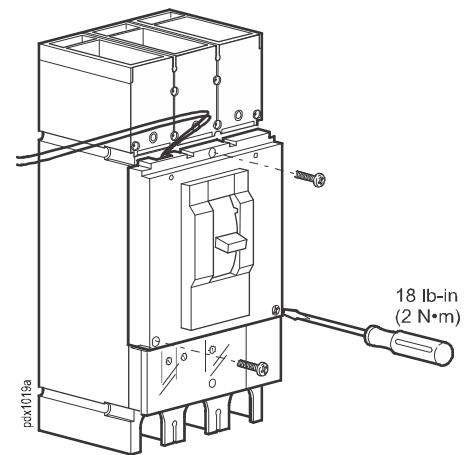

- 9 The cable can be routed through any appropriate hole in the top of the PDU. Use appropriate strain relief.

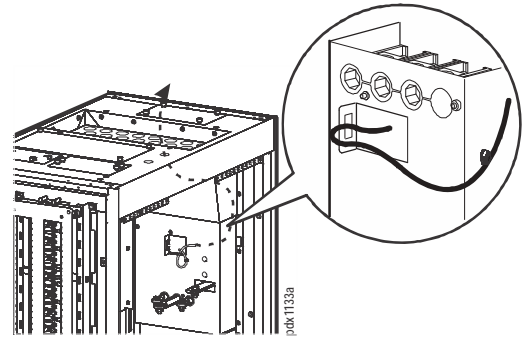

- 10 Use the tie down slots on the inside of the PDU to attach cable ties and secure the Shunt Trip cable. Maintain proper spacing from power cables.

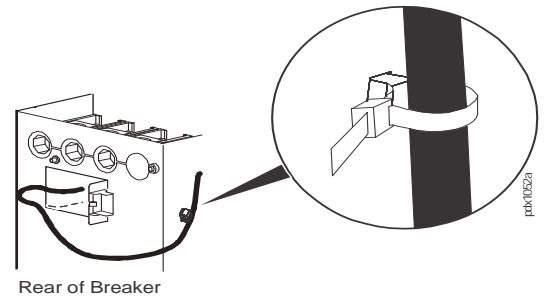

- 11 Replace the interior covers on the PDU before closing the door.

User Input/Output Contacts

NOTE: Contact wires from external signaling, alarming, and sensing devices may be connected to the interface board to allow the controller to monitor these devices and to also control outside devices through the output contacts.

Note the location of the interface board in the top of the PDU. Loosen the captive screws and remove the plate. Remove the 3/4 in (19mm) knockout.

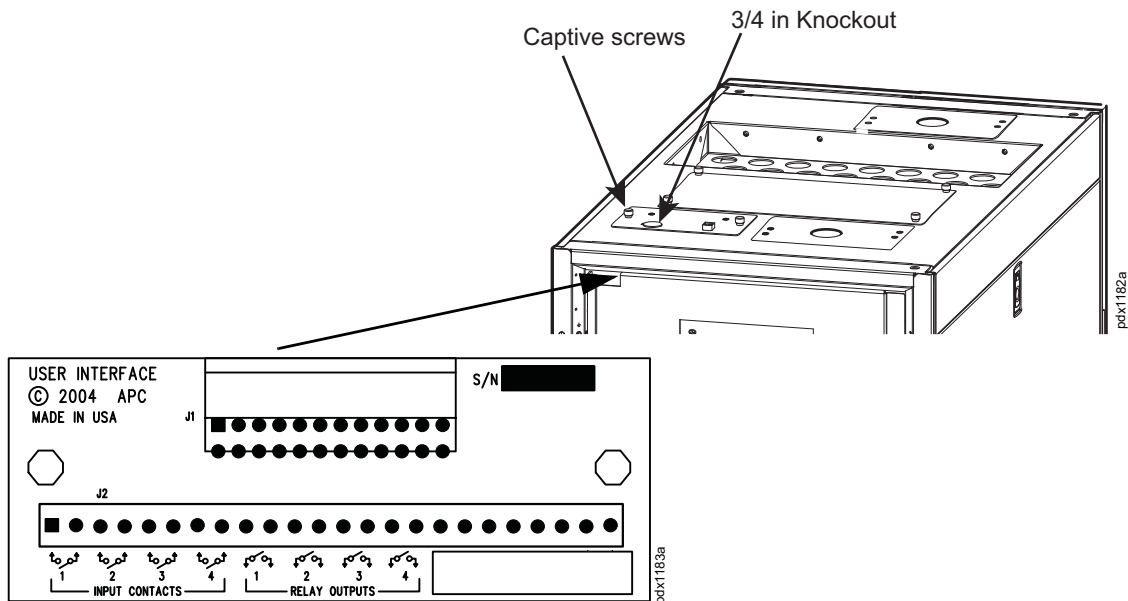

Run the contact cables through the hole to the interface board.

Make connections to the labelled terminals on the interface board.

NOTE: Input Contacts are Normally open.

Output Contacts: SPST N/O, 1A@30VDC. AS0, ATS1, ATS2, ATSEN, ATS EN, the +/- EPO 24V AC/DC positions, and both EPO CONTACT positions are reserved and not available.

Wiring: 18 AWG to 24 AWG is recommended

Network Communication Cable

Connect the network communication cable to the port located on the top of the enclosure. Connect the other end of the cable to your local area network. The other side of the port (inside the unit) is connected at the factory to another network cable.

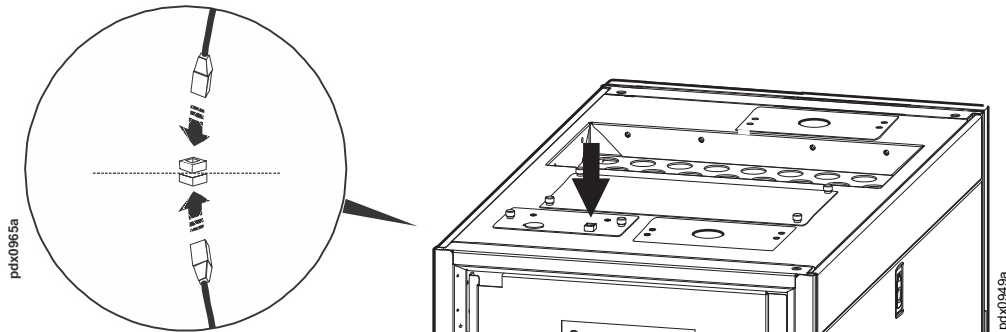

Route the cable through the cutout in the top of the drawer **1** and plug the jack into the port **2** on the Network Management Interface panel.

Modbus Connection

NOTE: See the Operation manual for set up instructions.

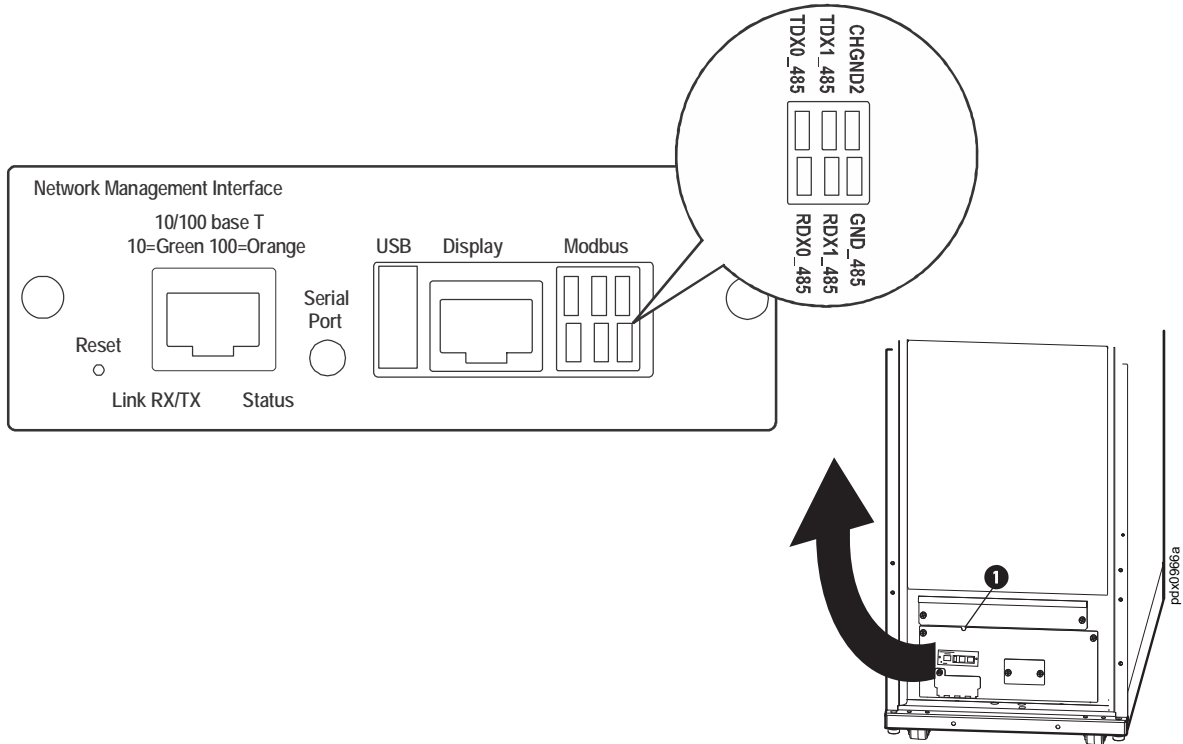

Optional Equipment

Seismic Stability Kit

Seismic side panel locks

- ❶ Remove the side panels from the end of row cabinets.

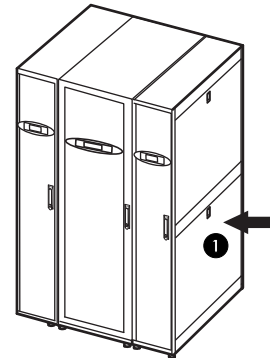

- ❷ Remove the standard lock. Use a screwdriver to press on the tab that secures the lock to the side panel.
- ❸ Pull the lock out and up and remove it from the side panel.

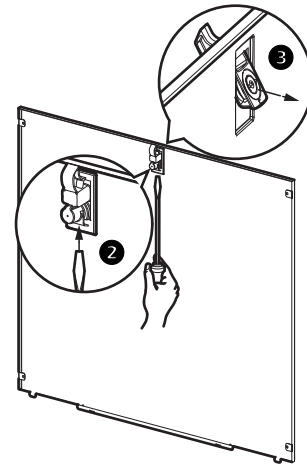

- ❹ Install the seismic lock. Put the two parts together.

- ❺ Loosely tighten the screws.

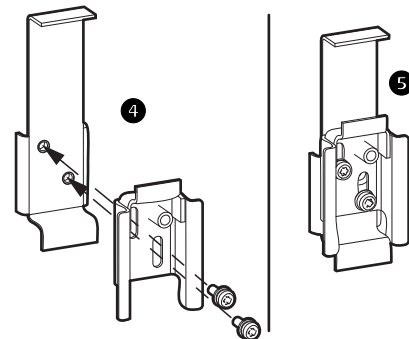

- 6 Place the side panel at an angle at the bottom of the frame.

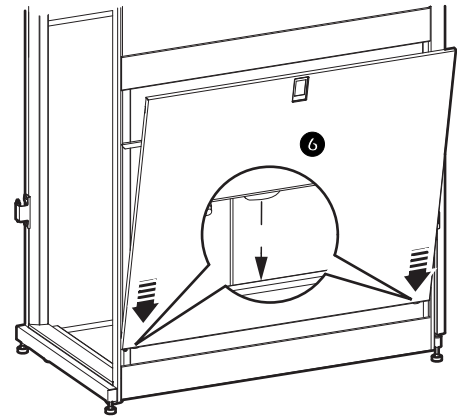

- 7 Push the top of the side panel in place.

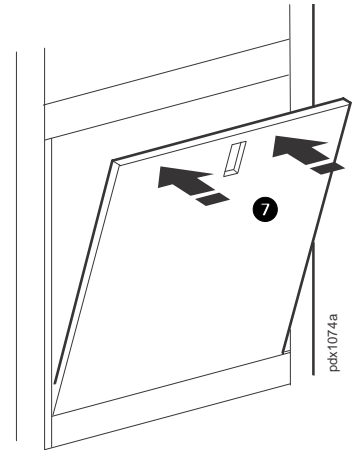

- 8 Hold the side panel with one hand.

Take the lock assembly and guide the top through the hole in the side panel.

Lift the lock assembly in place.

Ensure that the upper and lower tabs are hidden behind the side panel.

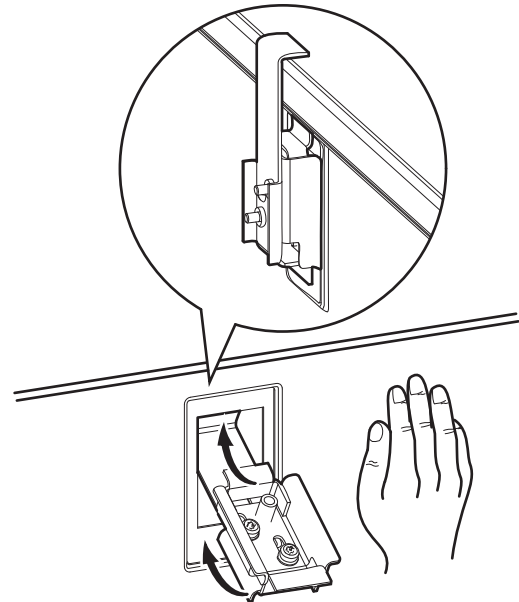

9 Secure the two screws in the lock assembly.

Install the lock cover using the provided screw.

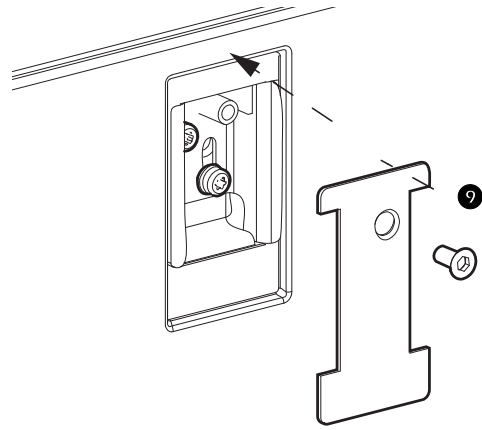

pdx1075a

Floor brackets

Install rear anchoring brackets

- 1 Secure the floor anchoring bracket to the floor using floor anchoring bolts (not supplied). Use M12 strength class 8.8 or 1/2 inch, grade 5 steel bolts.

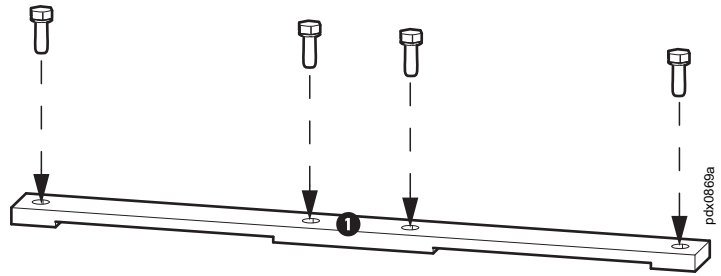

- 2 Secure the other half of the bracket assembly to the back of the unit.

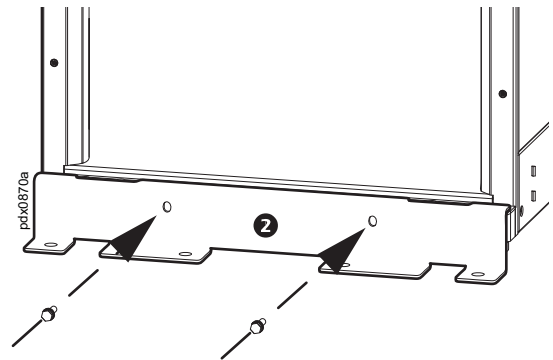

- 3 Push the PDU to slide the tabs on the bracket mounted to the PDU under the bracket bolted to the floor.

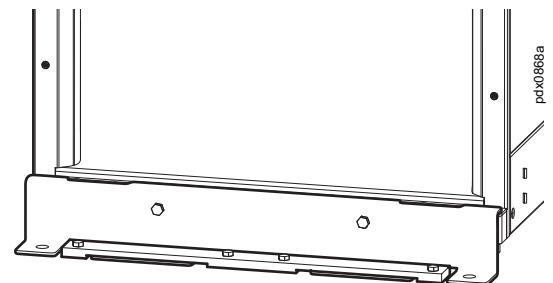
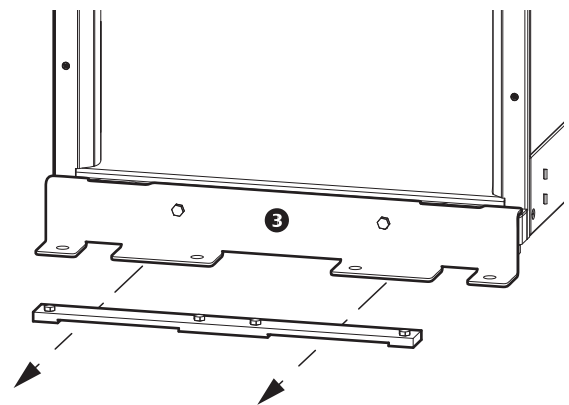

Install front anchoring bracket

- 1 Secure the front anchoring bracket to the enclosure.

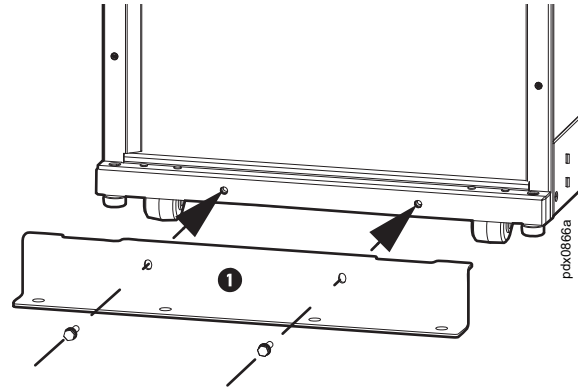

- 2 Secure the front anchoring bracket to the floor using floor anchoring bolts (not supplied). Use M12 strength class 8.8 or 1/2 inch, grade 5 steel bolts.

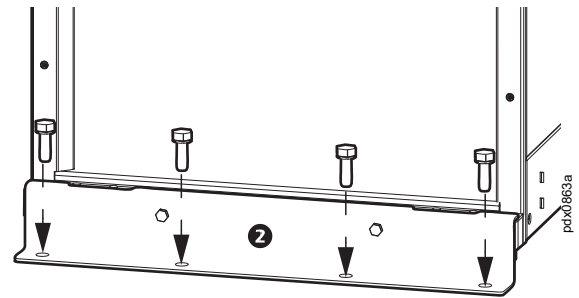

Roof stability brackets

The contents of the top stability kit are:

- two brackets
- four screws

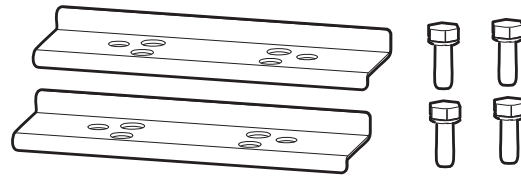

One top assembly bracket is attached at the front and one at the back over two adjacent cabinets. Secure with the four screws (included).

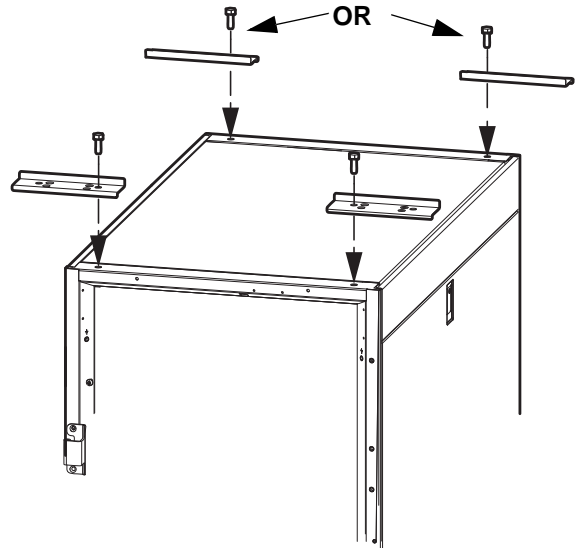

Roof brackets can be mounted on either side.

Shielding Troughs

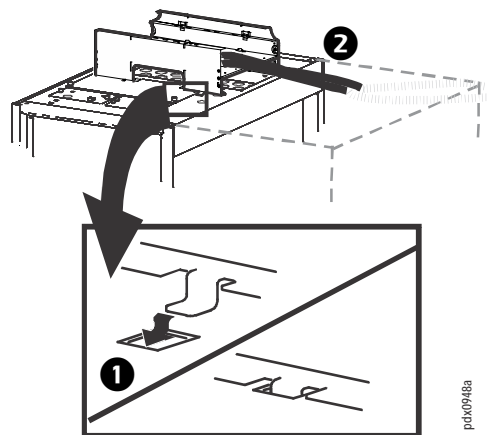

- ❶ Snap a Schneider Electric trough into slots on the roof of the PDU. The tabs at the base of the trough must fit securely into the slots.
- ❷ Feed the cables from the roof of the PDU into the trough system for connection with the appropriate rack-mount PDUs.

Post-Installation Checklist

- Check that the power wiring is properly torqued. See the specifications on page 12 for more information.

- Verify clockwise phase-rotation (L1, L2, L3). Make sure the GEC connection is present.

- Leave a wiring diagram on site for service personnel.

- Re-install all access panels.

- Re-mount the doors on all enclosures and connect the ground cables between the doors and the frames.

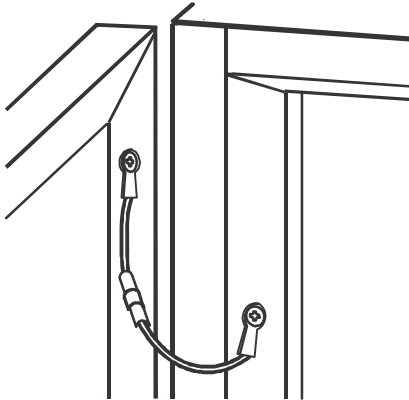

-
- For any optional equipment, refer to product-specific manuals.
-

Specifications

Values are based on 150 kW maximum and with Optional MBP configurations.

All electrical power and power control wiring must be installed by a qualified electrician, and must comply with local and national regulations for maximum power rating.

NOTE: Required Main supply is L1, L2, L3, GEC, and PE. Contact APC for information about other configurations. Ensure a clockwise voltage phase rotation (L1, L2, L3 or RST). Copper wiring must be used for input/output wiring.

	150 kW Maximum	De-rated to use with PX100 and MBP
Input (V)	480 V	480 V
Nominal input current (A)	186	165
Input frequency (Hz)	60	60
Maximum short circuit withstand level (kA)*	65	65
Main upstream current protection (A)	250A	225
Output (V)	208	208
Nominal output current (A)	416	278
Output frequency (on line, in bypass)	Synchronized to Input	
Output frequency (on battery) (Hz)	50/60	
Output current protection (A)	Square D QO, QOB, QH, QHB (15A to 150A)	
Subfeed Output (A)	125 to 400	125 to 250

* The maximum available fault current was not evaluated by Underwriters Laboratories.

Environment and Compliance	
Operating Environment	Protected from water and conductive contaminants
Temperature	Operating: 0 to 40°C (32 to 104°F) Storage: -25 to 65°C (13 to 149°F)
Humidity	Operating: 5 to 95%, non-condensing Storage: 5 to 95%, non-condensing
Elevation	Operating: 0 - 3048 m (0 - 10,000 ft) Storage: 0 - 15240 m (0 - 50,000 ft)
Certification	Listed and cUL by Underwriters Laboratories Inc.
Conditional Short-Circuit Current Rating (I _{cc})	10 kA

Full load heat loss at nominal main

- 150 kW: 8.42 kW

Recommended Conductor Sizes per Phase

This product may cause radio interference, in which case, the user may be required to take additional measures. Recommended Conductor Sizes per Phase/Neutral.

All wiring must comply with all applicable national and/or local electrical codes.

Conductor sizing in this manual is based on Table 310-16 of the National Electrical Code (NEC) with the following assertions.

- 90°C conductors (THHN) for 75°C termination
- 3 current carrying cable
- An ambient temperature of 30°C
- Use only copper conductors

If the ambient room temperature is greater than 30°C, larger conductors are to be selected in accordance with the correction factors of the NEC.

Equipment Grounding Conductors (EGC) are sized in accordance with NEC Article 250-122 and Table 250-122.

Grounding Electrode Conductors (GEC) are sized in accordance with NEC Article 250-66 and Table 250-66.

480VAC Standard rated (80%) 100% rated

Main Input	OCPD 80%	30C	40C	EGC	GEC
Copper (Cu)	250A	1 x 250 kcmil	1 x 300 kcmil	4AWG	2AWG
Aluminum (Al)	250A	1 x 350 kcmil	1 x 400 kcmil	2 AWG	1/0

Subfeed	# Current Carrying Conductors	30C	40C	PE
Copper (Cu)	3	2 x 3/0	2 x 4/0	3 AWG
Copper (Cu)	4	2 x 250 kcmil	2 x 300 kcmil	3 AWG
Aluminum (Al)	3	2 x 250 kcmil	2 x 300 kcmil	1 AWG
Aluminum (Al)	4	2 x 350 kcmil	n/a	1 AWG

Worldwide Customer Support

Customer support for this product is available at www.schneider-electric.com.

© 2015 Schneider Electric. All rights reserved.