

TeSys Control

Ultra motor starters





Introduction A4/2

TeSys Ultra - Power bases, control modules, connectors

Type of product	Range		Page
Standard power base, basic control functionalities Direct and reversing	Up to 18.5 kW		A4/10

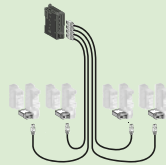
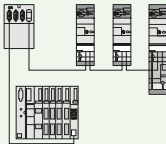
TeSys Ultra - Communication components

Parallel type cabling system Principle and components			A4/16
Bus type cabling systems Principle, panorama and components			A4/21
TeSys LUFPP communication gateway			A4/30

TeSys Ultra - Accessories

Short circuit current limiter			A4/31
Handles and accessories for rotary control			A4/32
Handles and accessories for integration into a MCC drawer			A4/33
TeSys Ultra with Altistart U01 Soft starters and Variable speed controllers			A4/34

Ultra
motor
starters

Technical Data for Designers A4/43

From traditional solution to ...

Ultra motor starters

Motor circuit breaker:
GV2L



Magnetic protection
> short-circuit protection

Contactor:
D



Control
> Start /Stop
Status monitoring
> signaling
> alarm monitoring

Protection relay:
LRD



Thermal protection
> overload

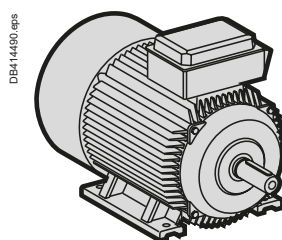

...Ultra motor starter



Ultra motor starters

Ultra motor starter

> All basic or advanced protection and control functions in one block and more...

- > Overload indication and alarm
- > Status report, remote control via communication bus

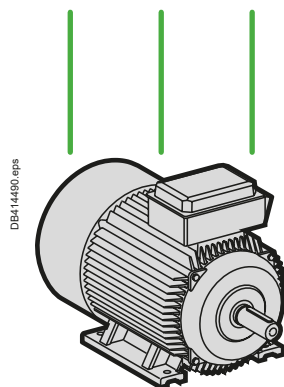

Ultra motor starters
can be used in **80 %** of motor protection and control applications.



1 All in one

- Optimising space in enclosures.
- Total coordination (No contact welding on short circuit).
- Reduces installation times.

2 Simplicity of choice

- Controlled power.
- Protection functions ensured.
- Signaling functions, communication with PLC ensured.

3 Universal mounting

- On DIN rail or grid.

4 Conventional projet design

- Conventional control scheme with start , stop push buttons.

5 Electrically simple

Basic scheme of a Ultra starter-controller

- Protection and power control functions acting on a single set of contact (QF1).
- The control unit (CU) monitors the voltage and current. In case of fault, it releases the coil, causing tripping.
- The coil is controlled by manual orders from an operator. Automatic control from a PLC is achieved with other diagrams.

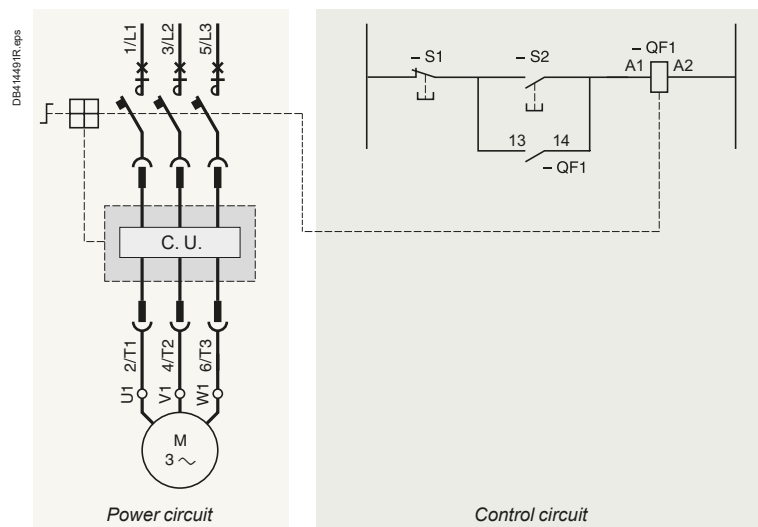

TeSys Control

Ultra motor starters

Introduction

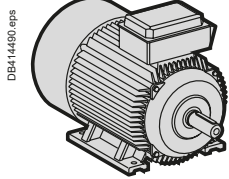

Motor up to

- 7.5 kW / 1-phase 230 V / 50-60 Hz.
- 18.5 kW / 3-phase 400-440 V / 50-60 Hz.
- 18.5 kW / 3-phase 500 V / 50-60 Hz.
- 22 kW / 3-phase 690 V / 50-60 Hz.
- Non-reversing or reversing.

Common characteristics

Short-circuit protection

- I_{sc}:
 - 50 kA at ≤ 400 V
 - 10 kA at 500 V
 - 4 kA at 690 V.
- Up to 690 V AC.

Overload protection

- From 0.15 to 38 A, 6 setting ranges (tripping 14.2 x I setting).
- Test button.
- Adjustment lock.
- Coil choice: 24 V, 48...72 V, 110...240 V DC/AC.

3 power contacts

- For non-reversing (reversing with reverser block).
- I_{max}, for 12 A power base (direct - reversing):
 - 12 A at up to 500 V / 50 Hz
 - 9 A > 500 V, up to 690 V.
- I_{max}, for 38 A power base (direct - reversing):
 - 38 A at up to 500 V / 50 Hz
 - 21 A > 500 V, up to 690 V.

1 NO contact

1 NC contact

- 5 A / max. 690 V AC or 250 V CC.

Other monitoring contacts

- 5 A / max. 690 V AC or 250 V DC.

Communication modules

- Modbus,
- Ethernet,
- CANopen,
- DeviceNet,
- Advantys stb,
- Profibus DP,
- AS-interface.

Dimensions

- Base:

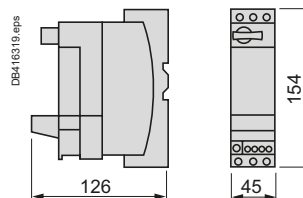

- Base + reverser block:

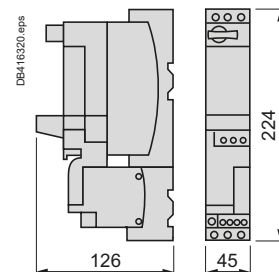

TeSys Control

Ultra motor starters

Introduction

DB-41483_eps

Ultra motor starters

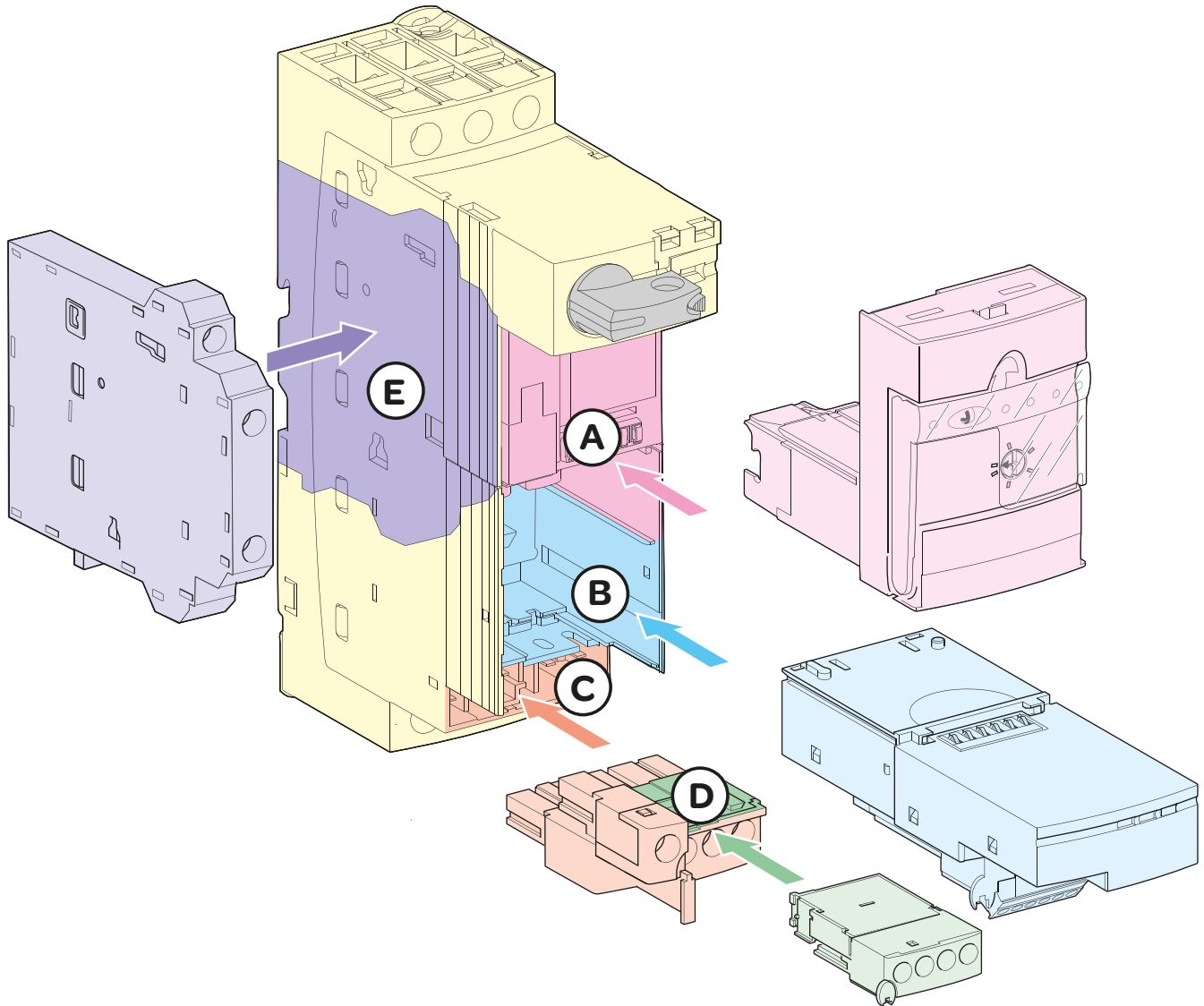

The modularity principle

- Power base
- (A) Cavity for control unit
- (B) Cavity for auxiliary module
- (C) Cavity for control terminal block
- (D) Cavity for additional contact block or shutter
- (E) Space for additional block fastening

Power Base

This is the basic constituent of the motor starter, it is composed of the power contacts, the control coil, the opening / closing mechanism of the protection device and the control pad.

Additional lateral block

Composed of the protection device signaling contacts.

Control unit

Composed of the power base management processor and setting knobs.

Auxiliary module

Depending on its type, it integrates load status contacts or a communication processor or an alarm processor.

Control terminal block

It is composed of two terminals "coil control", 1 NO auxiliary contact, 1 NC auxiliary contact. It can be eventually connected to an auxiliary communication module via a dedicated cable.

Additional block

It includes protection device additional signaling contacts. By default, this is a simple shutter.

TeSys Control

Ultra motor starters

Introduction

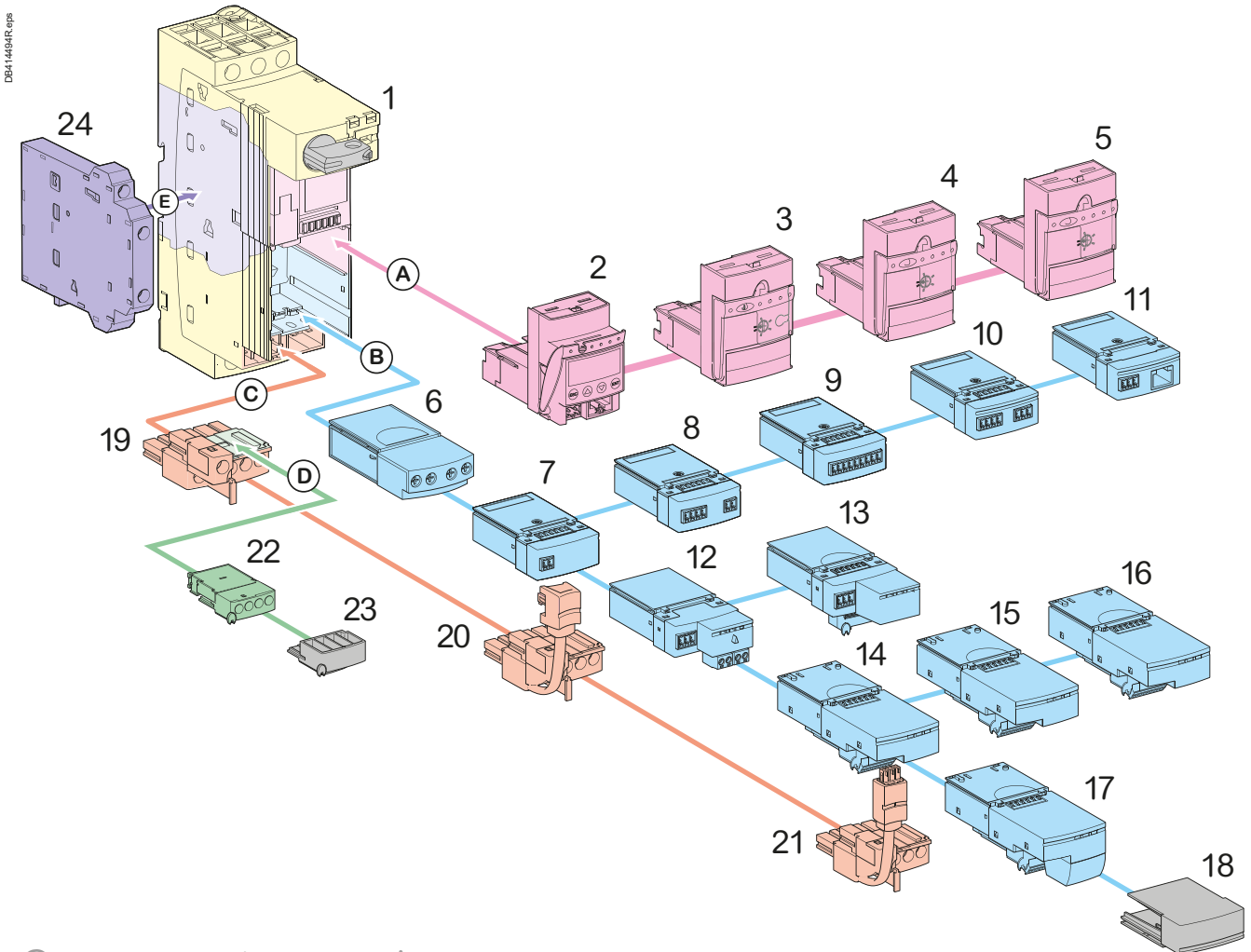

Ultra motor starters

Components overview

Power base

- 1- LUB
Non reversing power base - 1 rotation direction

Control units

- 2- LUCM
Multifunctional control unit
- 3- LUCB/LUCC/LUCD
Advanced control units
- 4- LUCA
Standard control unit
- 5- LUCL
Magnetic protection control unit

Auxiliary module

- 6- LUFN
Auxiliary contacts module

Load monitoring auxiliary modules

- 7- LUFW10
Overload alarm module
- 8- LUFDH11
Overload alarm module with manual reset
- 9- LUFDA01/LUFAD10
Overload alarm module with automatic reset/remote reset
- 10- LUFV2
Motor load indication module

Communication auxiliary modules

- 11- L UFC00
Telefast parallel liaison module, with RJ45 connector
- 12- ASILUFC5/ASILUFC51
AS-Interface c. m.
- 13- LULC033
Modbus c. m.
- 14- LULC07 Profibus DP c. m.
- 15- LULC08 CANopen c. m.
- 16- LULC09 DeviceNET c. m.
- 17- LULC15 Advantys STB c. m.

Shutters

- 18- LU9C1
Shutter for module cavity
- 23- Shutter for contacts additional block cavity

Control terminal blocks

- 19- LU9BN11
Terminal block for imbedded auxiliary contacts
- 20- LU9BN11C
Coil terminal block with its connecting cable
- 21- LU9BN11L
Coil terminal block with its connecting cable

Additional contacts blocks

- 22- LUA1
Additional contacts
- 24- LUA8
side-mounting additional contacts

DB41445R.eps

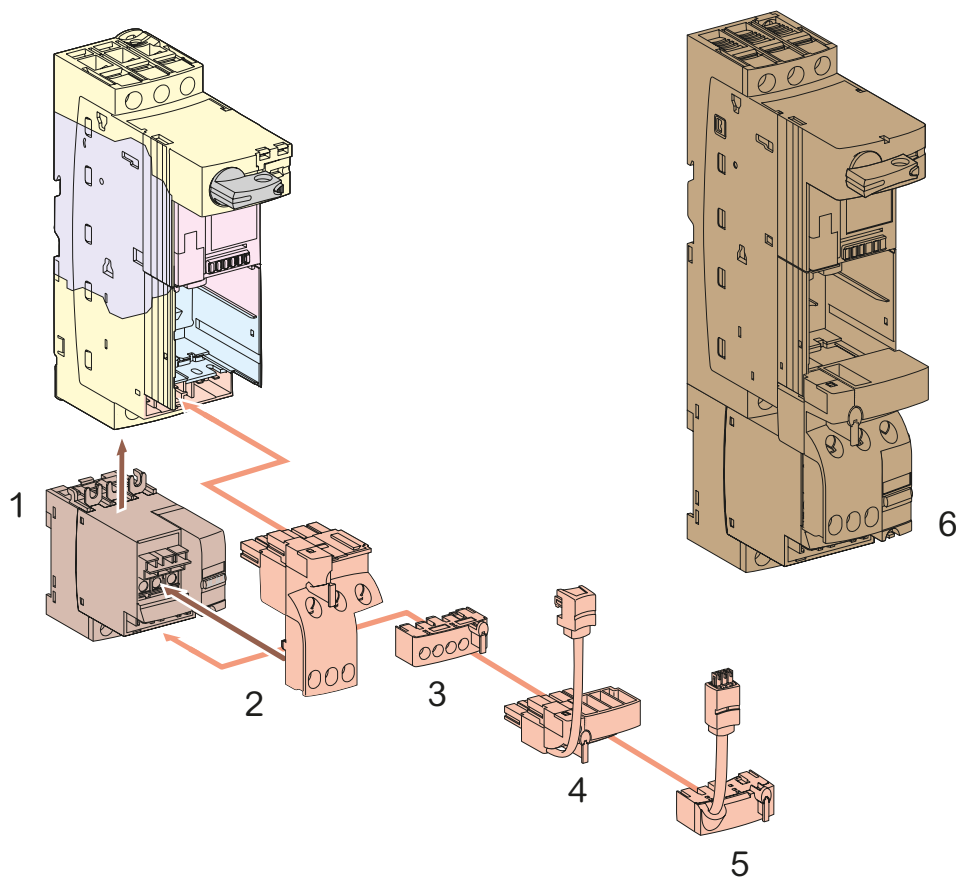

Ultra motor starters

Additional components overview

Reverser block

- 1- LU2MB0●●
vertical-mounting reverser block

Evolving reversing power base

- 6- Pre-assembled reversing power base LU2B12

Control terminal blocks

- 2- LU9MR1C
Base/block assembling connector, with terminal block for imbedded auxiliary contacts
- 3- LU9M1
Coil terminal block for wired control
- 4- LU9MRC
Coil terminal block with its connecting cable for communicating control (only compatible with a selection of com. modules).
- 5- LU9MRL
Coil terminal block with its connecting cable for communicating control (only compatible with a selection of com. modules).

TeSys Control

Ultra motor starters

Introduction

DB414497 eps

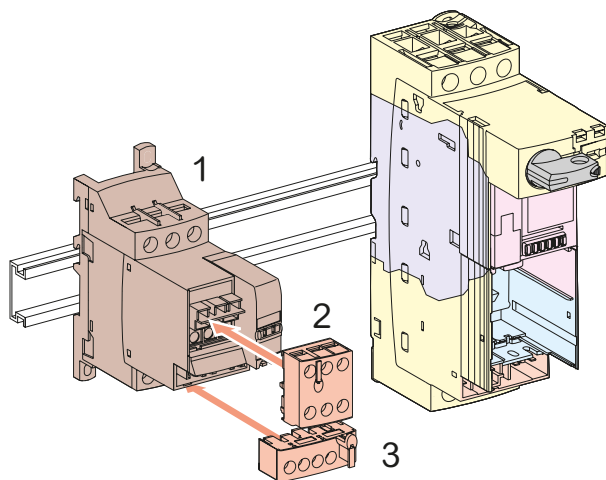

Ultra
motor
starters

Additional components overview

Reverser block

- 1- LU6MB0●●
Side-mounting reverser block

Terminal blocks for electrical remote control

- 2- LU9MR1
Terminal block for 2 direction control (pulse or maintained control)
- 3- LU9M1
Terminal block for power base coil interlocking.
With direction of rotation monitoring contacts

TeSys Control

Ultra motor starters - Power bases

Product references



1 direction:
LUB12, LUB32, LUB38



1 direction:
LUB120, LUB320, LUB380
*LU9BN11: Terminal block
for embedded auxiliary
contacts to be ordered
separately.



2 direction:
LU2B12●●, LU2B32●●,
LU2B38●●



LU9MR1C



LU2MB0●●



LU6MB0●●



LU9M1



LU9MR1

Power bases

Ultra starters are composed with separate elements: power component + control units + auxiliary components.

The power base includes the electro mechanical parts. It is selected according to:

- Motor power to be handled
- Number of direction of rotation to be controlled: 1 or 2
- Type of control to be achieved: Basic or Advanced.

Basic control

- 1- direction rotation control
- 2 - direction rotation control
- Overload + Short circuit protection
- Main power monitoring
- Status signaling contacts

Advanced control

- Functions of basic control
- + Digital display of electrical values
- + Overload alarms
- + Network/bus communication

Function	Max motor standard power (400 V) kW	Lip_in (400 V) A	References	
			Basic ctrl	Advanced ctrl
1-direction rotation	5.5	12	LUB12	LUB120
	15	32	LUB32	LUB320
	18.5	38	LUB38	LUB380
2-direction rotation	5.5	12	LU2B12●● ⁽¹⁾	LUB120 + reverser block ass.
	15	32	LU2B32●● ⁽¹⁾	LUB320 + reverser block ass.
	18.5	38	LU2B38●● ⁽¹⁾⁽²⁾	LUB380 + reverser block ass.

(1) Replace the 2 dots by the coil voltage code below – AC is 50-60 Hz.

(2) With BL or FU code only.

Coil voltage (V)	24---	24~	48...72 --- or ~	110...220 --- and 110...240~
Code	BL	B	ES	FU

Please check the availability of your variant in the index page A4/42. The SEARCH function of your viewer can be used.

Reverser blocks - assemblies

A reverser block assembly has to be added to the power base (LUB120 to 380) to build an 'Advanced control' with '2-direction of rotation' Ultra starter.

Reverser blocks with 2 mounting possibilities:

- vertical mounting– mounted aspect: refer to LU2B12, 32, 38
- side mounting, on a Din rail.

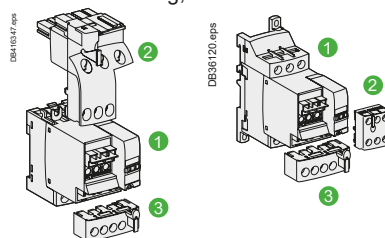

Vertical mounting Side mounting

Blocks	References	
	Vertical mounting	Side mounting
1 Reverser block	LU2MB0●● ⁽¹⁾	LU6MB0●● ⁽¹⁾
2 Aux. contacts connector	LU9MR1C	LU9MR1
3 Coil supply connector	LU9M1	LU9M1

(1) Replace the 2 dots by the coil voltage code below – AC is 50-60 Hz.

Coil voltage (V)	24---	24~	48...72 --- or ~	110...220 --- and 110...240~
Code	BL	B	ES	FU

Main technical characteristics

Power bases

1-direction power base overall dimensions (HxWxD) : 154 x 45 x 126 mm

2-direction power base (assembly with vertical mounting reverser block) overall dimensions (HxWxD): 224 x 45 x 126 mm

Power bases are delivered with protective blanking plates.

3 power poles, for connections of a 1-phase or 3-phase motor

Screw clamp power terminals, for up to 2 x 6 mm² conductors

Screw clamp control terminals, for up to 2 x 1.5 mm² conductors

LUB12,32,38 imbedded terminals:

- coil supply,
- NO (13-14) contact (for control push button)
- NC (21-22) contact (for control push button).

Additional signaling contact modules provide more possibilities.

Reversing assemblies

LU2MB0, LU6MB0:

3 power poles, for connections of a 1-phase or 3-phase motor,

screw clamp power terminals, for up to 2 x 6 mm² conductors

LU9 connectors: screw clamp control terminals, for up to 2 x 1.5 mm² conductors

LU2MB0●●, LU6MB0●● provide terminals for power circuits.

LU9MR1C, LU9MR1 provide signalling contact terminals (82-81-84) that indicate the direction of rotation.

LU9M1 provides coil supply terminals (A2-A1-A3) and 2 NO contact terminals (A1-B1, A3-B3) for direction control.

TeSys Control

Ultra motor starters - Control units

Product references



LUCA, LUCB, LUCC, LUCD, LUCL series.
Ex.: LUCA05BL

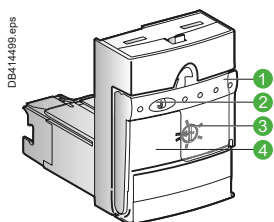

LUCA●●●●

- 1 Extraction and locking handle.
- 2 Sealing of locking handle.
- 3 Ir adjustment dial.
- 4 Locking of settings by sealing the transparent cover.

Ultra starters are composed with separate elements: power component + control units + auxiliary modules. The control unit includes electronic components and the current adjustment dial. The control unit is selected according to:

- Motor power to be handled.
- Type of protection: thermal+magnetic or magnetic only.

Control units for power bases with basic control

LUCA - thermal + magnetic (standard) units

- Protection against overload: 14.2 x Ir (setting current).
- Protection against short circuit: 13 x Ir max (max setting current).
- Protection against missing or unbalanced phases.
- Protection against insulation fault (protection of equipment only).
- Class 10 tripping.
- Frequency 50...60 Hz.

LUCL - magnetic units

- Protection against short circuits.
- To be used when a standard power base is connected to a motor drive or a soft starter, as they provide the overload protection.

Note: both LUCA and LUCL units can be used in the advanced power bases LUB120 and LUB320.

Maximum standardized power ratings of 3 phases motors 50/60 Hz			Setting range	Lip in mounting on the power base - Rating	Control unit product reference ⁽¹⁾	
400/440 V	500 V	690 V			Thermal + magnetic	Magnetic
kW	kW	kW	A	A	LUCA	LUCL
0.09	-	-	0.15...0,6	12 and 32	LUCAX6●●	LUCLX6●●
0.25	-	-	0.35...1,4	12 and 32	LUCA1X●●	LUCL1X●●
1.5	2.2	3	1.25...5	12 and 32	LUCA05●●	LUCL05●●
5.5	5.5	9	3...12	12 and 32	LUCA12●●	LUCL12●●
7.5	9	15	4.5...18	32	LUCA18●●	LUCL18●●
15	15	18.5	8...32	32	LUCA32●●	LUCL32●●
18.5	18.5	22	9.5...38	38	LUCA38●● ⁽²⁾	LUCL38●● ⁽²⁾

⁽¹⁾ Replace the 2 dots by the coil voltage code below – AC is 50-60 Hz.

⁽²⁾ With BL or FU code only.

Coil voltage (V)	24---	24~	48...72 --- or ~	110...220 --- and 110...240~
Code	BL	B	ES	FU

Please check the availability of your variant in the index page A4/42. The SEARCH function of your viewer can be used.



TeSys Control

Ultra motor starters - Control units

Product references

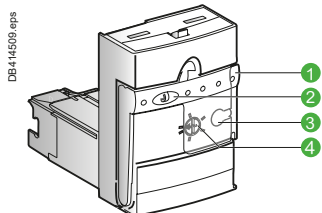

LUCB●●●●, LUCC●●●●, LUCD●●●● control units

- 1 Extraction and locking.
- 2 Handle sealing of locking.
- 3 Handle
- 4 Ir adjustment dial test push button.

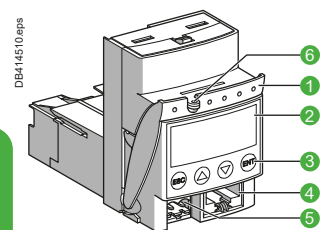

LUCM●●BL control unit

- 1 Extraction and locking handle.
- 2 Built-in LCD display (2 lines, 12 characters).
- 3 4 button keyboard.
- 4 RJ45 connector for RS485 Modbus communication
- 5 Connector for external 24 V DC power supply.
- 6 Sealing of locking handle.

Ultra motor starters



LUCM12BL

Control units for power bases with advanced control

LUCB, LUCC, LUCD control and diagnostic units

Motor protection, fault diagnostic.

Protection against

- overload: 14.2 x Ir (setting current).
- Simulation of an overload by depressing the test push button.
- short circuit: 13 x Ir max (max setting current).
- missing or unbalanced phases.

Overload alarm management:

- locally: with one of the LUF family module
- Remotely: with LULC031, LULC033, LULC07, LULC08, LULC09 or LULC15 (thermal alarm only) communication module.

Reset:

- manual
- automatic, with a communication module.

LUCM multifunctional control unit

Motor protection, operational values display and diagnostic.

To be associated with 24 V DC coil only.

LUCM●●BL: tripping class 5 to 30, single phase, three phase

Same functions as LUCB●●●● with complementary functions:

- in working mode: display of electrical values, setting parameters and events
- in configuration mode: display of protection and alarm settings.

These functions are available for local display on a display panel, and for remote display via a RJ45 Modbus connector.

LUCM is not compatible with LUB38.

Note: a 24 V DC power supply is required during the configuration process.

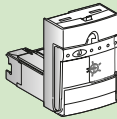
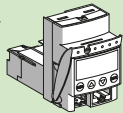
Maximum standardized power ratings of 3 phases motors 50/60 Hz				Lip_in mounting on the power base - Rating	DBA 14695 eps 	Protection type: - overload - short-circuit - Main power fault - alarm			DBA 14504 eps 
400/440 V	500 V	600 V	Setting range			Multifunctional			
kW 1P 3P	kW 3P	kW 3P	A	A	Class 10 3P	Class 10 1P	Class 20 3P	Class 5...30 1 - 3P	
- 0.09	-	-	0.15...0.6	12 and 32	LUCB6●●	LUCC6●●	LUCD6●●	LUCM6BL	
0.09 0.25	-	-	0.35...1.4	12 and 32	LUCB1X●●	LUCC1X●●	LUCD1X●●	LUCM1XBL	
0.55 1.5	2.2	3	1.25...5	12 and 32	LUCB05●●	LUCC05●●	LUCD05●●	LUCM05BL	
2.2 5.5	5.5	9	3...12	12 and 32	LUCB12●●	LUCC12●●	LUCD12●●	LUCM12BL	
4 7.5	9	15	4.5...18	32	LUCB18●●	LUCC18●●	LUCD18●●	LUCM18BL	
7.5 15	15	18.5	8...32	32	LUCB32●●	LUCC32●●	LUCD32●●	LUCM32BL	
18.5 18.5	22	9.5...38	38		LUCB38●● ⁽¹⁾		LUCD38●● ⁽¹⁾		

Cial. ref. of the control unit: replace dots by the coil code.

Please check the availability of your variant in the index page A4/42. The SEARCH function of your viewer can be used.

Coil voltage (V)	24---	24~	48...72 --- and 48~	110...220 --- and 110...240~
Coil code	BL	B	ES	FU

⁽¹⁾ With BL or FU code only.

TeSys Control

Ultra motor starters - Signaling Modules/Blocks - Function modules

Product references

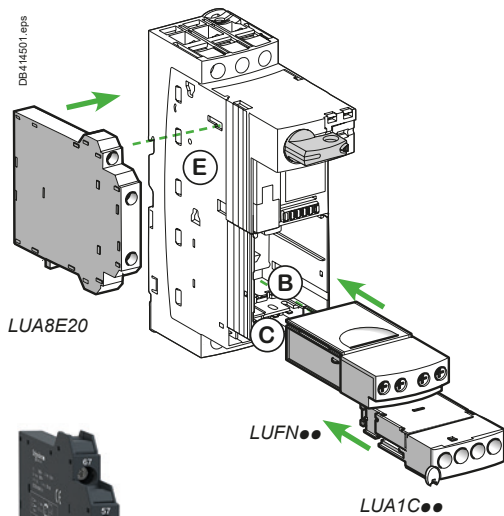

LUA8E20



LUA8E20

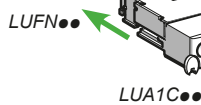

LUA1C



LUFN02



LUA1C20



LUFV2



LUFW10



LUFDH11



LUFDA01



LUFDA10

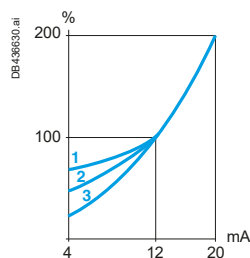

- 1 2.2 kW
- 2 4 kW
- 3 7.5 kW

LUFV2 typical response curve

Signaling module and blocks

They provide dry contacts of Normally Open (NO) or Normally Closed (NC) type for signaling purpose. The monitored status can be either the motor running status or the protection device status, depending on the commercial reference of the module or block.

Common electrical characteristics

Standard operating voltage: 24...250 V AC/DC.

Maximum current: 5 A.

Compatibility - Positioning

The signaling module and blocks can be used in any power base

LUA8E20 is clipped on the E side of the power base

LUFN11, LUFN02, LUFN02 inserted into B cavity

LUA1C20, LUA1C11 inserted into C cavity

Note: B and C cavities may be already used for reverser-starter, communication.

Signaling module and blocks	Output	References
Module	1 NO + 1 NC	LUFN11
Motor running status: ON / OFF	2 NC	LUFN02
	2 NO	LUFN20
Block	2 NO	LUA1C20
Protection status: OPEN / CLOSED (OF) STANDBY / TRIPPED (SD)	1 NO + 1 NC	LUA1C11
	2 NO	LUA8E20
Side block	2 NO	LUA8E20
Protection status: OPEN / CLOSED (OF)		

Function modules

They provide analog output or dry contacts of Normally Open (NO) or Normally Closed (NC) type for measurement or signaling purpose.

Common electrical characteristics

Standard operating voltage: 24...250 V AC/DC.

Maximum current: 5 A.

Compatibility - Positioning

The function modules can only be used in a LUB120, LUB320 or LUB380 power base, in cavity B.

Function modules	Output type	References
Electrical value: average current in each phase. The signal is the image of the percentage of I_n . External 24 V DC power supply needed	Analog: 4-20 mA	LUFV2
Contact closes if average current in the phases = 105 % of I_n	1 NO	LUFW10
Contacts change state if tripping is caused by overload	1 NO + 1 NC	LUFDH11
Contact opens if overload tripping is reset with control pad or remotely	1 NC	LUFDA01
Contact closes if overload tripping is reset with control pad or remotely	1 NO	LUFDA10

TeSys Control

Ultra motor starters - Communication modules

Product references



LUFC00

Auxiliary parallel wiring module ⁽¹⁾

Auxiliary parallel wiring module for Modicon Telefast system

Inputs

They collect the FWD, REV controls from an automation process. An RJ45 parallel port is used, for connection to the 24 V DC outputs of a PLC.

Outputs

They give the position of the control pad and the state of the poles. They provide 24 V DC controls to the LUB120, 320 or 380 power base coil via the LU9BN11C adapter (A2, A1) or to the LU2B12, 32, 38 power base coil with a LU9MRC adapter (A2, A1, A3).

Compatibility - Positioning

The parallel wiring module can only be used in any Ultra power base, with **LUC●●● control unit with coil voltage**

Compatible with:

- Modicon TM3 (map I/O controllers for RJ45 M221, M241, M25)
- Modicon STB modules (I/O for automation island)
- Modicon Telefast (interfaces RJ45/HE10).

The parallel wiring module is inserted in cavity B.

Note: the parallel wiring module must be connected to a LU9G02 or LU9G03 Telefast distribution

Note: more details on parallel wiring page A4/16.

Designation	References
Ultra power base parallel wiring module	LUFC00

Ultra motor starters



LULC033



ASILUFC51



LULC07



LULC15



LU9BN11C



LU9BN11L

Communication modules

Communication modules

These modules send the control pad position and pole state to a communicating system (PLC, monitoring system,...)

They collect the Forward, Reverse motor controls from an automation process.

The status and controls are coded according to an industrial communication protocol, depending on the communication module.

Bus cable connection, external power supply by crew clamp terminals.

Connector for coil control (to A1-A3-A2) via a prewired connection (LU9BN● for 1-direction control, LU9MR● for 2-direction control)

Compatibility - Positioning

The communication modules can only be used in a LUB120, LUB320 or LUB380 power base, in cavity B.

Designation	References
Ultra Modbus communication module	LULC033
Ultra AS-Interface communication module	ASILUFC51
Ultra Profibus DP communication module	LULC07
Ultra CANopen communication module	LULC08
Ultra DeviceNet communication module	LULC09
Ultra Advantys STB communication module	LULC15

Note: Ethernet communication can be achieved with LULC033 + ConneXium Port (ref. TCSEQM113M13M)

Note: more details on bus-type communication page A4/21.

Prewired connectors

They provide the necessary electrical link between a parallel or communication module and the coil supply connector, on the power base or reverser block. Thus, ON-OFF (1 direction) or FORWARD-REVERSE (2 direction) controls can be achieved.

Prewired connection	References	Compatibility with modules
1 direction Short cable	Side connection LU9BN11C	LUFC00, LULC033, ASILUFC51
	Bottom connection LU9BN11L	LULC07, 08, 09, 15
2 direction Long cable	Side connection LU9MRC	LUFC00, LULC033, ASILUFC51
	Bottom connection LU9MRL	LULC07, 08, 09, 15



LU9MRC



LU9MRL

TeSys Control

Ultra motor starters - Parallel-type cabling systems

Introduction

PB 106098 eps

Ultra motor starters



Point-to-point wiring

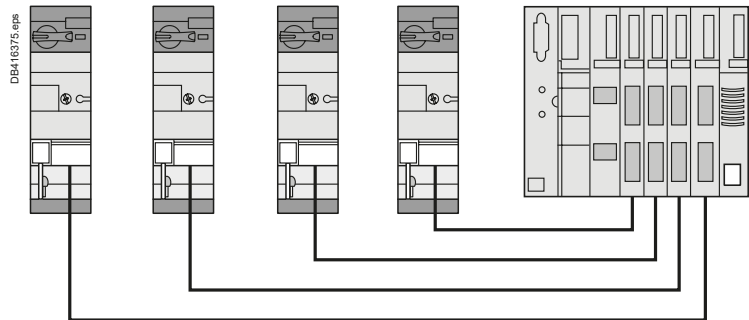

- The control inputs and signaling outputs of the starter are grouped in a single socket, usually RJ45. They are individually connected to PLC outputs and inputs.
- The wires run in parallel in a multicore cable equipped with a multipin connectors, RJ45 in the case of Telefast type system.
- 3 parallel wiring systems are available:
 - Modicon TM3, based on a RJ45 I/O module for M221, M241, M25 PLC
 - Modicon STB, based on I/O modules for automation island
 - Modicon Telefast: RJ45 / HE10 interfaces.
- Simple way of proximity wiring. Quick cabling. It is suitable for machine control panels when a large number of Ultra starter-controller are installed.

informations

- The control and signaling terminals of the starters are connected to the output and input terminals of a PLC. No specific connectors or cables are required.
- Conventional wiring mode, without optimization of the cabling time. May be suitable when a very small number of starters is used, with a very small number of links.

Parallel cabling systems

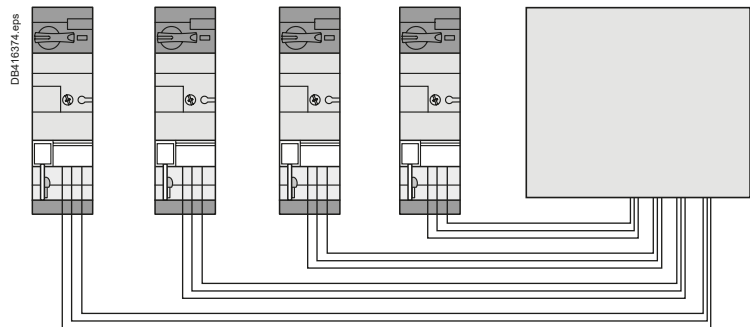

TeSys Control

Ultra motor starters - Parallel-type cabling systems

Introduction

Integration in the Modicon TM3 wiring system

The Ultra starter-controller are directly connected to a I/O module equipped with RJ45 connectors.

- 1 Modicon M221, M241, M251 PLC's
- 2 TM3XTY I/O module for 4 starters
- 3 LU9R●● cables with RJ45 connectors,
- 4 LUFC00 module for TeSys Control parallel connection (1 or 2 direction of rotation).

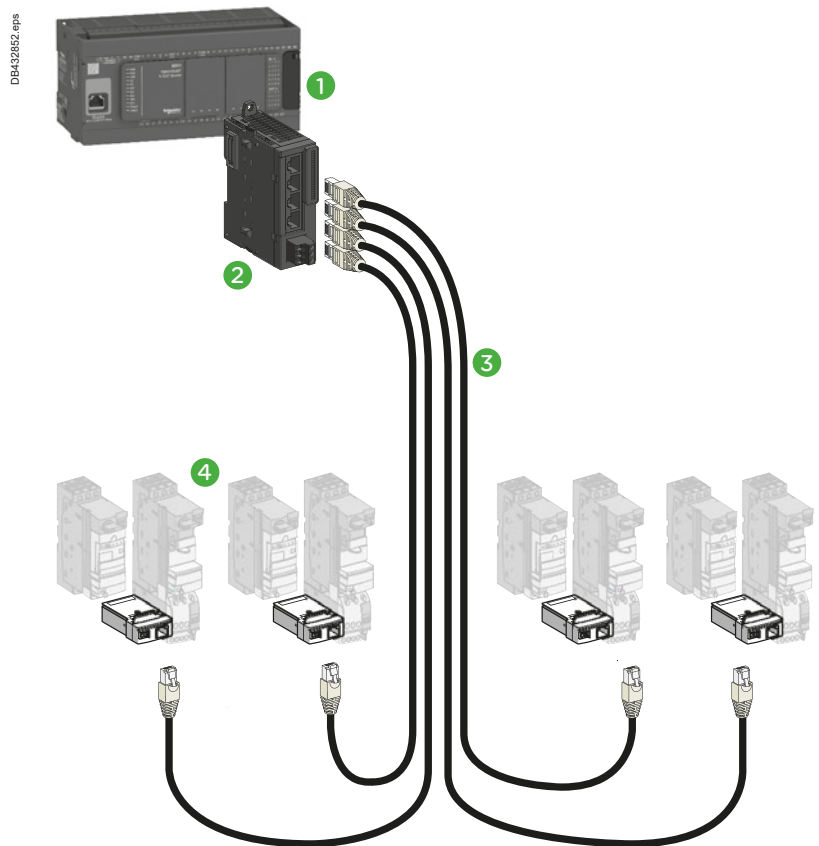

Ultra
motor
starters

TeSys Control

Ultra motor starters - Parallel-type cabling systems

Introduction

Integration in the Modicon Advantys STB system

Advantys STB is a solution for remote I/O modules.

These communicate with the Modicon PLCs range thanks to a serial liaison, using the Advantys STB protocol.

In this example an Advantys I/O module is used to facilitate wiring.

Each of its four terminals receives a preassembled RJ45 cable connected to a Ultra starter-controller.

- 1 Ultra LUB120, 320 or 380 power base (equipped with 24 V DC LUC●●●●BL control modules)
- 2 TeSys Control module for parallel RJ45 wiring: LUFC00 + LU9BN11C (one direction) or LU9MRC (2 directions for LU2B12, 32 or 38 power base)
- 3 RJ45 cables (2 connectors):
≤ 3 m: LU9R●●
> 3 m: 490 NTW000●● (5, 12, 40 or 80 m)
- 4 PLC: Modicon range
- 5 I/O Modicon Advantys module: STB EPI 2145K

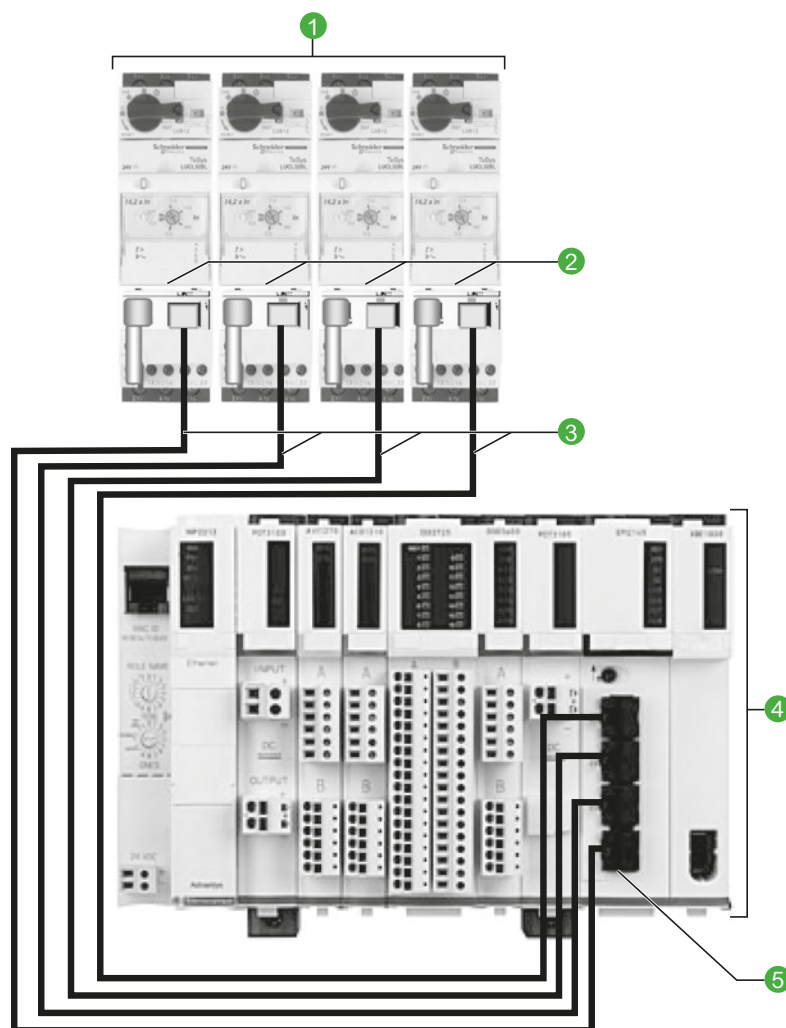

TeSys Control

Ultra motor starters - Parallel-type cabling systems

Introduction

Integration in the Modicon Telefast system

The wiring hubb **LU9G0** facilitates the connection to Modicon Premium PLCs. It adapts RJ45 connectors to HE10 available on the Telefast I/O modules. Connection: up to 8 Ultra per hubb.

- 1 Ultra LUB120, 320 or 380 power base (equipped with 24 V DC LUC.....BL control units)
- 2 TeSys Control module for parallel wiring RJ45: LUFC00 + LU9BN11C (one direction) or LU9MRC (2 directions for LU2B12, 32 or 38 power base)
- 3 RJ45 cables (2 connectors):
≤ 3 m: LU9R...
> 3 m: 490 NTW000... (5, 12, 40 or 80 m)
- 4 Telefast RJ45 / HE10 splitter box: LU9G02 or LU9G03 (different Ultra connection capacities)
- 5 HE10 cables (2 connectors): TSXCDP...
- 6 PLC: Modicon Premium range
- 7 I/O module: TSX DMY 28FK

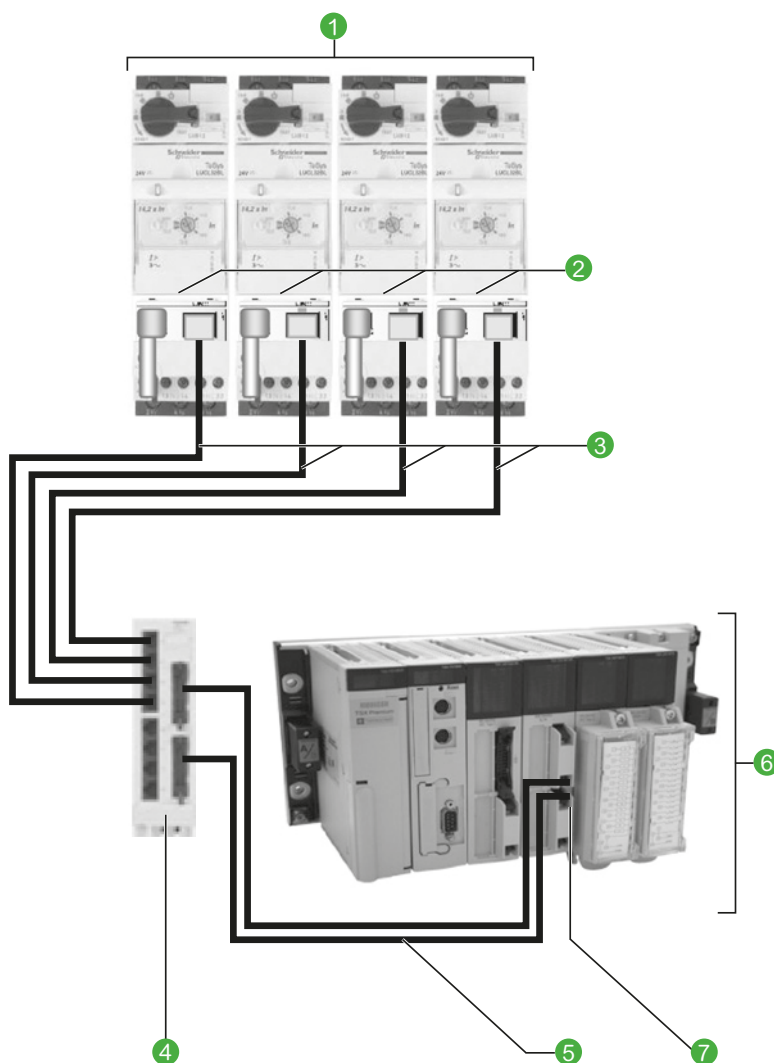

Ultra
motor
starters

TeSys Control

Ultra motor starters - Parallel-type cabling systems

Product references

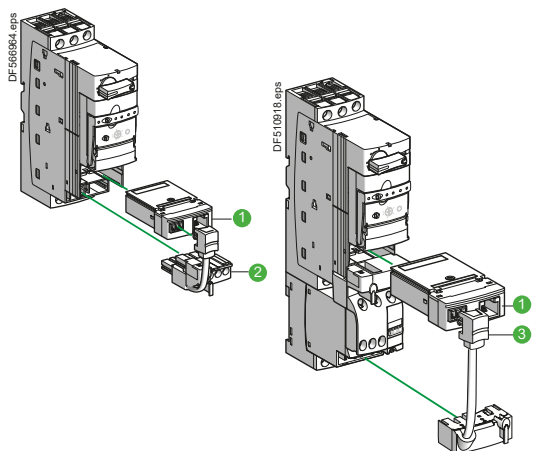

Components for connection of a starter - 1 direction of rotation	
Designation	Reference
① Parallel connection module, RJ45 output 2 coil control inputs, 3 signal outputs	LUFC00
② Pre wired connector, one direction of rotation, for LUB120, 320 or 380 power base coil connection and one contact for emergency stop	LU9BN11C

Components for connection of a starter - 2 directions of rotation	
Designation	Reference
① Parallel connection module, RJ45 output	LUFC00
③ Pre wired connector, 2 directions of rotation, for LU2B12, 32 or 38 power base coil connection and one contact for emergency stop	LU9MRC

Ultra motor starters



LU9G02



LU9G03

Telefast RJ45/ HE10 splitter box	
Designation	Reference
<p>Splitter box</p> <p>Connection to U:</p> <p>4 RJ45 connectors: for 1 to 4 U, 1 or 2 directions</p> <p>4 RJ45 connectors: for 1 to 4 U, 1 direction</p> <p>Connection to PLC:</p> <p>1 x HE10 connector - 20 channels, for pole status, alarms</p> <p>1 x HE10 connector - 20 channels, for control.</p> <p>24 V DC auxiliary power supply required</p>	LU9G02
<p>Splitter box</p> <p>Connection to U:</p> <p>8 RJ45 connectors: for 1 to 8 U, 1 or 2 directions</p> <p>Connection to PLC:</p> <p>1 x HE10 connector - 20 channels, for pole status, alarms</p> <p>1 x HE10 connector - 20 channels, for control.</p> <p>24 V DC auxiliary power supply required.</p>	LU9G03

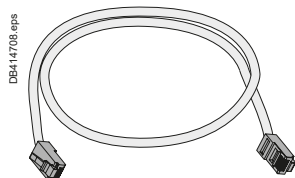

RJ45 cables.

RJ45 connection cables, with 2 RJ45 connectors	
0.3 m	LU9R03
1 m	LU9R10
3 m	LU9R30

HE10 connection cables, with 2 HE10/20 way connectors	
Section: AWG 22 / 0.324 mm ²	
0.5 m	TSXCDP053
1 m	TSXCDP103
2 m	TSXCDP203
3 m	TSXCDP303
5 m	TSXCDP503
Section: AWG 28 / 0.080 mm ² (flat cable)	
1 m	ABFH20H100
2 m	ABFH20H200
3 m	ABFH20H300

Cable with stripped wires (PLC side)	
1 x HE10/20 ways connector (Splitter box side)	
Section: AWG 22 / 0.324 mm ²	
3 m	TSXCDP301
5 m	TSXCDP501

TeSys Control

Ultra motor starters - Bus-type cabling systems

Introduction

PB105992.eps



> Application functionality, topology

1 Geographically expanded process

Many motors are scattered on the site, the process control requires individual control to ensure safety and proper operation. Ultra is a suitable communicating actuator. The integration of a bus communication module in the starter-controller saves space in the control board and simplifies wiring, compared to solutions based on conventional components (circuit breaker + contactor).

2 Application: automatic motor control / monitoring

Thanks to a communication bus, starter-controllers are part of an automation system controlled by a PLC and (or) various communicating controllers. These equipment can then share the status and alarm information related to each motor control and perform specific treatments.

3 Bus-type connection

This type of connection allows different topologies (star, ring ...) and supports various protocols dialogue. It is therefore recommended for geographically expanded process, in order to to simplify wiring and ensure multiple-controller management.

Ultra motor starters

- The bus wiring interconnects Ultra starters controllers and components of the installation via a single the cable.
- Commands and status are coded according to the selected protocol and transmitted on the communication bus.
- This wiring is simple, usually a shielded (or not) pair of wires, suitable for monitored automation, regardless of the number of Ultra and their locations.

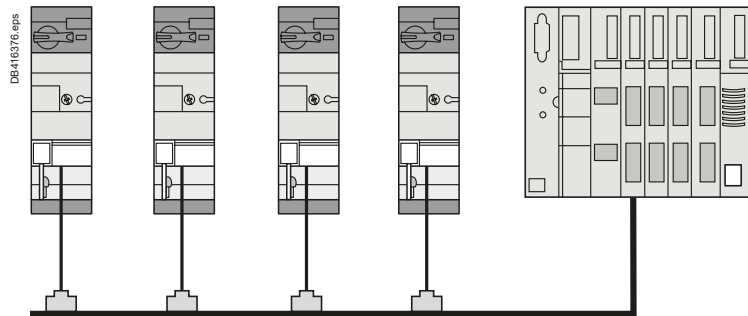

Available Ultra status and controls via a communication module

Control unit	LUCA	LUCB LUCC LUCD	LUCM
Starter status (ready, running, fault)	■	■	■
Start and Stop commands	■	■	■
Thermal overload alarm		■	■
Remote reset via the bus		■	■
Indication of motor load		■	■
Fault signalling and differentiation		■	■
Remote programming and monitoring of all functions			■
"Log" function			■
"Monitoring" function			■
Alarms (overcurrent, ...)			■

TeSys Control

Ultra motor starters - Bus-type cabling systems

Introduction

Network

Architecture

Component references

Modbus

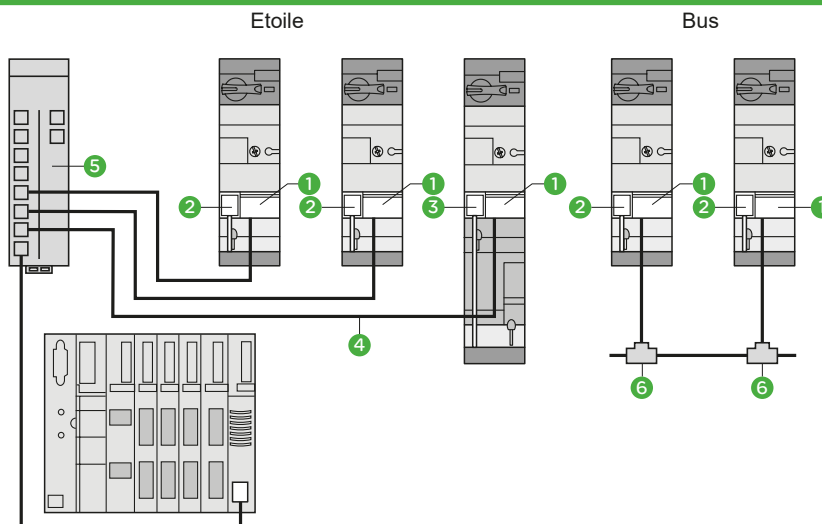

- 1 LULC033
- 2 LU9BN11C
- 3 LU9MRC
- 4 VW3A8306R●●●
- 5 LU9GC3
- 6 VW3A8306TF

Ultra motor starters

Details page
[A4/26](#)

Advantys STB

Starter-controllers communicate using ADVANTYS STB protocol to fit into a remote I/O architecture.

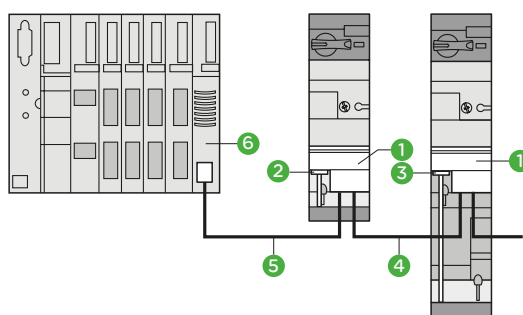

- 1 LULC15
- 2 LU9BN11L
- 3 LU9MRL
- 4 LU9RDD●●●
- 5 LU9RCD
- 6 STBxBE1100

Details page
[A4/27](#)

TeSys Control

Ultra motor starters - Bus-type cabling systems

Introduction

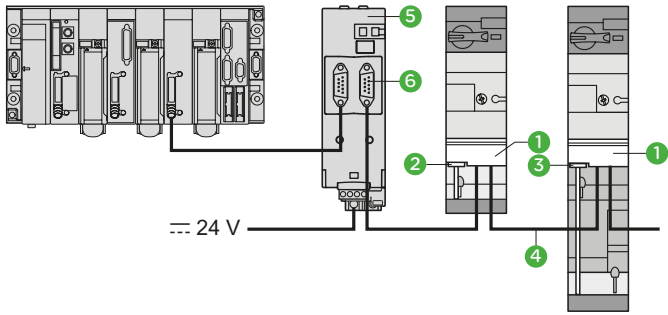
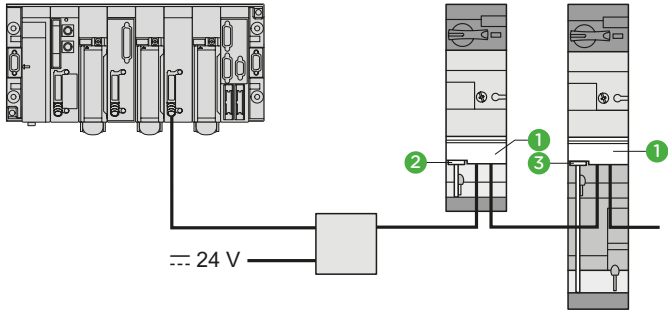
Network	Architecture	Component references
<p>Profibus-DP (Decentralized Peripherals)</p> <p>is used for connecting actuators and sensors to a central controller for applications in industrial production. The standard bus provides a number of diagnostic means</p> <p>Details page A4/28</p>		<ul style="list-style-type: none"> ① LULC07 ② LU9BN11L ③ LU9MRL ④ LU9RPB010 LU9RPB100 LU9RPB400 ⑤ LU9AD7 ⑥ LU9GC7
<p>DeviceNet</p> <p>Details page A4/29</p>		<ul style="list-style-type: none"> ① LULC09 ② LU9BN11L ③ LU9MRL

Ultra motor starters

TeSys Control

Ultra motor starters - AS-Interface communication modules

Product references

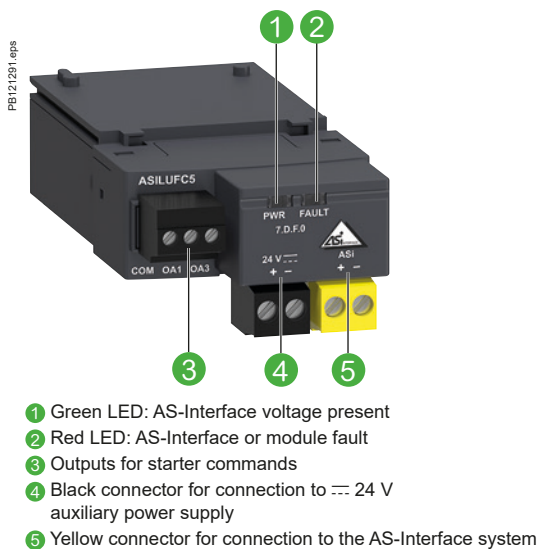

The ASILUFC5 communication module, combined with the power base and control unit is used to control Ultra starters-controllers via DeviceNet bus. The LULC09 communication module is slave type.

Module Specifications

I/O terminal block

- Powered by external 24 V DC (power supply not included):
- 2 x configurable inputs for binary sensors
- 1 x 24 V DC output - 0.5 A local auxiliary command.

Connectors

- For Ultra 24 V DC coil (common, direction 1, direction 2).
- For AS-Interface bus.

Signaling

- Module Status - Error - 24 V, by LED.

Ultra motor starters

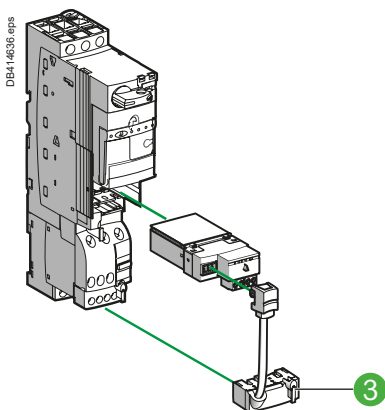
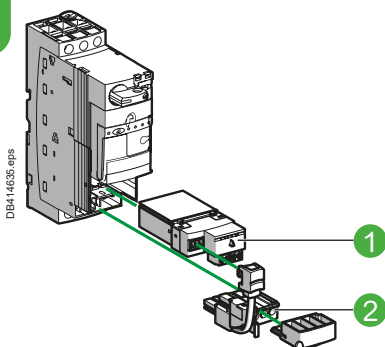

Tesys Control components

Description	Mark	Max number of slaves	References
AS-Interface communication module	1	31	ASILUFC5
		62	ASILUFC51
Pre-wired connector: coil - LUB powerbase	2	-	LU9BN11C
Pre-wired connector: coil - LU2B powerbase	3	-	LU9MRC

TeSys Control

Ultra motor starters - CANopen communication module

Product references

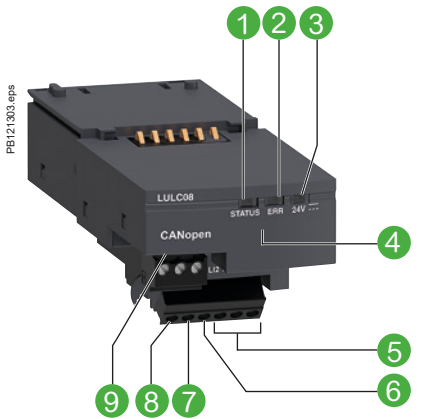

- 1 LED indicating module status
- 2 Fault signalling LED
- 3 LED indicating 24 V supply ON for outputs OA1, OA3 and LO1
- 4 SUB-D connector for bus link
- 5 24 V supply connection
- 6 Discrete input
- 7 Discrete input
- 8 Discrete output
- 9 Outputs for starter commands

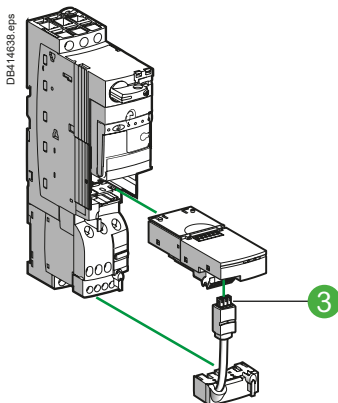
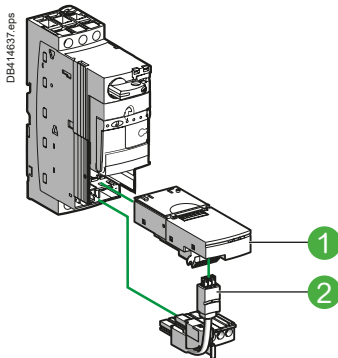

The LULC08 communication module, combined with the power base and control unit is used to control Ultra starters-controllers via CANopen bus. The LULC08 communication module is slave type.

Module Specifications

I/O terminal block

- Powered by external 24 V DC (power supply not included):
 - 2 x configurable inputs for binary sensors
 - 1 x 24 V DC output - 0.5 A local auxiliary command.

Connectors

- For Ultra 24 V DC coil (common, direction 1, direction 2).
- For CANopen bus.

Signaling

- Module Status - Error - 24 V, by LED.

Tesys Control components

Description	Item	References
CANopen communication module	1	LULC08
Pre-wired connector: coil - LUB powerbase	2	LU9BN11L
Pre-wired connector: coil - LU2B powerbase	3	LU9MRL

Compatibility of CANopen communication module with control units

LUCA ●●BL / B ●●BL / C ●●BL / D ●●BL	All versions marketed after 2T0481 ⁽¹⁾
LUCM●●BL	All versions ≥ V3.2
LUCMT1BL	All versions ≥ V3.2

(1) This "date code" is made up as follows:
 2T or 2C: factory code.
 04, 05, 06 and so on: year of manufacture.
 08: week.
 1: 1st day of the week.

How to get information on the design of a CANopen architecture and the choice of network accessories

Consult the library of downloadable documents on schneider-electric.com by searching on the name of the communication protocol.

TeSys Control

Ultra motor starters - Modbus communication module

Product references

LULC033

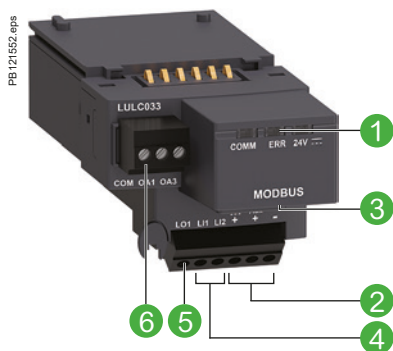

- 1 Module status signalling LED
- 2 24 V supply connection
- 3 RJ45 connector for RS485 Modbus link
- 4 2 discrete inputs
- 5 1 discrete output
- 6 Outputs for starter commands

Ultra motor starters

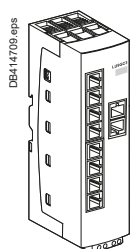
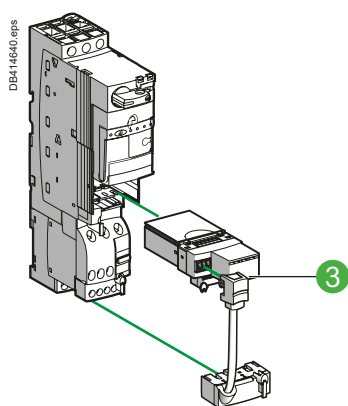
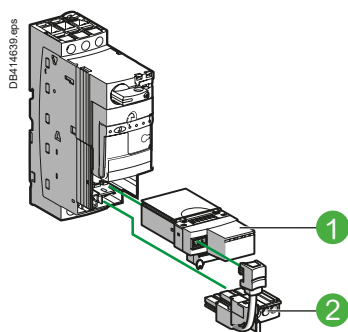

LULC033 communication module, combined with the power base and control unit is used to control Ultra starters-controllers via Modbus.

Module Specifications

I/O terminal block

- Powered by external 24 V DC (power supply not included):
- 2 x configurable inputs for binary sensors (on LULC033 only)
- 1 x 24 V DC output - 0.5 A local auxiliary command.

Connectors

- For Ultra 24 V DC coil (common, direction 1, direction 2).
- RJ45, For Modbus line.

Signaling

- Module Status - Error - 24 V, by LED.

Tesys Control components

Description	Item	Bin. input	References
Modbus communication module	1	2	LULC033
Pre-wired connector: coil - LUB powerbase	2	-	LU9BN11C
Pre-wired connector: coil - LU2B powerbase	3	-	LU9MRC

Modbus hub

Description	Length (m)	References
Modbus communication distributor	-	LU9GC3
Cables fitted with 2 x RJ45 connectors	0.3	VW3A8306R03
	1	VW3A8306R10
	3	VW3A8306R30
Tees derivations	0.3	VW3A8306TF03
	1	VW3A8306TF10

Description	References
RS 485 line terminator	VW3A8306R

Compatibility of Modbus communication modules

Communication modules (software version)		LULC033 from V2.1	LULC033 from V2.2
Power base	LUB●● / LU2B●2	■	■
	LUTM●●BL	■	■
Control unit	LUCA●●BL		■
	LUCB●●BL		■
	LUC●●BL		■
	LUCD●●BL		■
	LUCM●●BL		■ ⁽¹⁾
	LUCBT●●BL	■	
	LUCDT●●BL	■	
	LUCMT●●BL	■	

(1) Except LUCM●●BL V1.04 and V1.06.

How to get information on the design of a Modbus architecture and the choice of network accessories

Consult the library of downloadable documents on schneider-electric.com by searching on the name of the communication protocol.

TeSys Control

Ultra motor starters - Advantys STB communication module

Product references

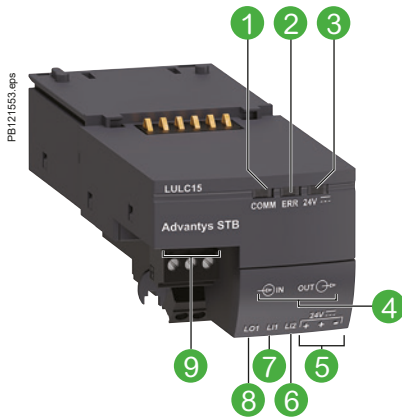

- 1 Two-colour LED indicating module status
- 2 Fault signalling LED
- 3 LED indicating that 24 V supply is ON
- 4 Bus connectors
- 5 24 V supply connection
- 6 Discrete input
- 7 Discrete input
- 8 Discrete output
- 9 Outputs for starter commands

Communication module LULC15 allows direct connection of Ultra starter-controllers and controllers on an Advantys STB island, between two segments or at the end of a segment. The starter-controller will then be able to make use of the services provided by Advantys STB: self-addressing, autobaud, fallback positions.

Module Specifications

I/O terminal block

- Powered by external 24 V DC (power supply not included):
 - 2 x configurable inputs for binary sensors (on LULC033 only)
 - 1 x 24 V DC output - 0.5 A local auxiliary command.

Connectors

- For Ultra 24 V DC coil (common, direction 1, direction 2).
- For Advantys STB bus.

Signaling

- Com - Error - 24 V, by LED.

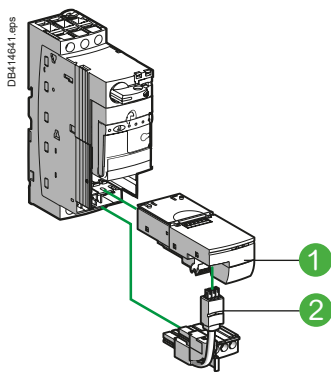

LUB + LULC15 + LU9BN11L

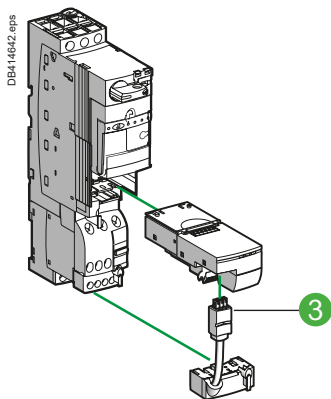

LU2B + LULC15 + LU9MRL

Tesys Control components

Description	Item	References
Advantys STB communication module	1	LULC15
Pre-wired connector: coil - LUB powerbase	2	LU9BN11L
Pre-wired connector: coil - LU2B powerbase	3	LU9MRL

Cables

Description	Length (m)	References
Cables fitted with connectors, one straight and one elbowed	0.3	LU9RCD03
	1	LU9RCD10
	5	LU9RCD50
Cables fitted with two straight connectors	0.3	LU9RDD03
	3	LU9RDD30

Compatibility of Advantys STB communication module with control units

LUCA●●BL / B●●BL / C●●BL / D●●BL	All versions marketed after 2T0481 ⁽¹⁾
LUCM●●BL	All versions ≥ V3.2
LUCMT1BL	All versions ≥ V3.2

(1) This "date code" is made up as follows:
 2T or 2C: factory code.
 04, 05, 06 and so on: year of manufacture.
 08: week.
 1: 1st day of the week.

How to get information on the design of a Advantys STB architecture and the choice of network accessories

Consulter la librairie des documents téléchargeables sur le site schneider-electric.com en faisant une recherche sur le nom du protocole de transmission.

TeSys Control

Ultra motor starters - Profibus DP communication module

Product references

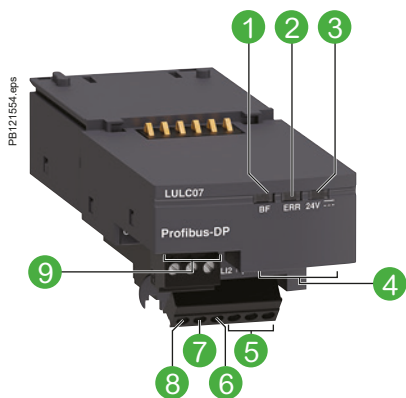

- 1 Two-colour LED indicating module status
- 2 Fault signalling LED
- 3 LED indicating 24 V supply ON for outputs OA1, OA3 and LO1
- 4 SUB-D connector for bus link
- 5 24 V supply connection
- 6 Discrete input
- 7 Discrete input
- 8 Discrete output
- 9 Outputs for starter-controller commands (non-reversing and reversing)

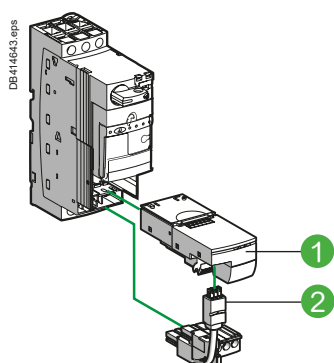

LUB + LUC...BL + LULC07 + LU9BN11L

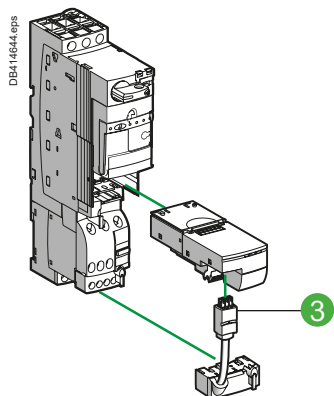

LU2B + LUC...BL + LULC07 + LU9MRL

When used in conjunction with the power base and control unit, communication module LULC07 allows Ultra starter-controllers to be controlled via Profibus DP (Deported Periphery) bus. Communication module LULC07 is of the slave type.

Module Specifications

I/O terminal block

- Powered by external 24 V DC (power supply not included):
 - 2 x configurable inputs for binary sensors
 - 1 x 24 V DC output - 0.5 A auxiliary command.

Connectors

- For Ultra 24 V DC coil (common, direction 1, direction 2).
- For Profibus DP bus.

Signaling

- Com - Error - 24 V, by LED.

Tesys Control components

Description	Item	References
Profibus DP communication module	1	LULC07
Pre-wired connector: coil - LUB powerbase	2	LU9BN11L
Pre-wired connector: coil - LU2B powerbase	3	LU9MRL

Components for connection to the bus and to the installation

The 24 V DC -Aux supply to Profibus DP modules LULC07 must pass through power supply module LU9GC7.

LULC07 modules must be connected to the LU9GC7 splitter box in order to be powered.

The number of Ultra starter-controllers that can be powered by an LU9GC7 module is limited by the maximum current (1.5 A) which it can deliver.

The 24 V supply for the inputs/outputs must be provided separately..

Description	Length (m)	References
Profibus DP power supply module	-	LU9GC7
Profibus DP connector	-	LU9AD7
Profibus DP cables 2-wire	100	TSXPBSCA100
	400	TSXPBSCA400
Profibus DP cables 4-wire	10	LU9RPB010
	100	LU9RPB100
	400	LU9RPB400

How to get information on the design of a Profibus DP architecture and the choice of network accessories

Consult the library of downloadable documents on schneider-electric.com by searching on the name of the communication protocol.



TeSys Control

Ultra motor starters - DeviceNet communication module

Product references

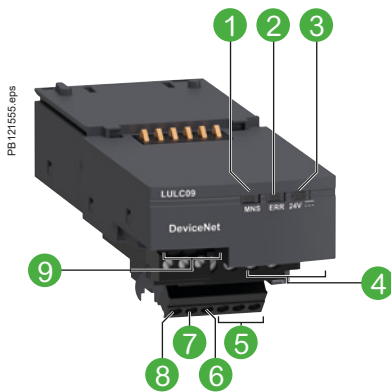

- 1 LED indicating module status
- 2 Fault signalling LED
- 3 LED indicating $\overline{\text{24 V}}$ supply ON for outputs OA1, OA3 and LO1 and 24 V bus
- 4 DeviceNet connector for bus link
- 5 $\overline{\text{24 V}}$ supply connection
- 6 Discrete input
- 7 Discrete input
- 8 Discrete output
- 9 Outputs for starter-controller commands (non-reversing and reversing)

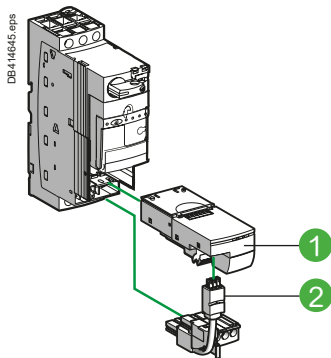

LUB + LUC●●●BL + LULC07 + LU9BN11L

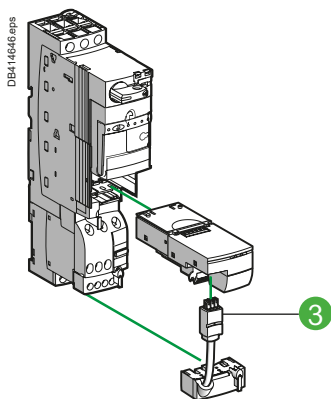

LU2B + LUC●●●BL + LULC07 + LU9MRL

When used in conjunction with the power base and control unit, communication module LULC09 allows Ultra starter-controllers to be controlled via DeviceNet bus. Communication module LULC09 is of the slave type.

Module Specifications

I/O terminal block

- Powered by external 24 V DC (power supply not included):
- 2 x configurable inputs for binary sensors
- 1 x 24 V DC output - 0.5 A local auxiliary command.

Connectors

- For Ultra 24 V DC coil (common, direction 1, direction 2).
- For DeviceNet bus.

Signaling

- Com - Error - 24 V , by LED.

Tesys Control components

Description	Item	References
DeviceNet communication module	1	LULC09
Pre-wired connector: coil - LUB powerbase	2	LU9BN11L
Pre-wired connector: coil - LU2B powerbase	3	LU9MRL

How to get information on the design of a DeviceNet architecture and the choice of network accessories

Consult the library of downloadable documents on schneider-electric.com by searching on the name of the communication protocol.

TeSys Control

Ultra motor starters - LUF communication gateways

Product references

PB 121537 eps



LUF9

Ultra motor starters



DF526109-17-M eps



561512 eps

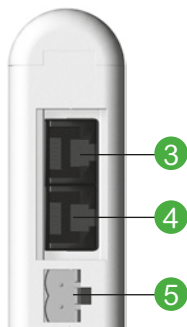

Introduction

LUF communication gateways allow connection between the Modbus serial link and Fipio, Profibus DP or DeviceNet field buses.

After configuration, these gateways manage information which can be accessed by the Modbus serial link and make this information available for read/write functions (command, monitoring, configuration and adjustment) on the field buses.

An LUF communication gateway consists of a box which can be clipped onto a 35 mm omega rail, allowing connection of up to 8 Slaves connected on the Modbus serial link.

Example of architecture

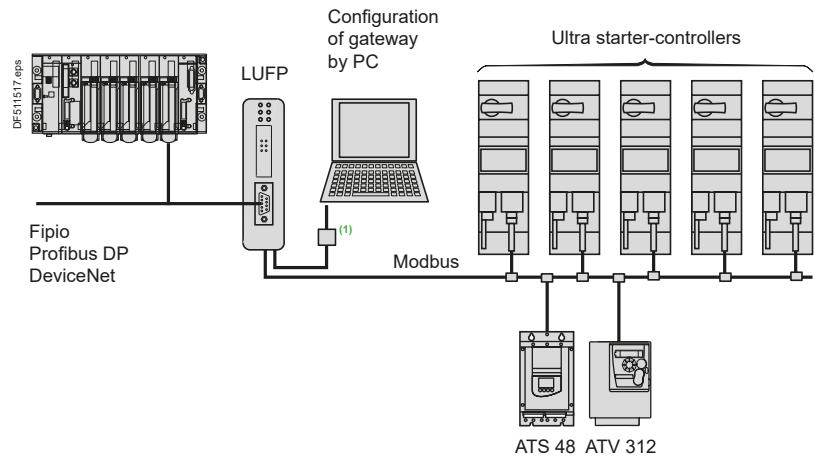

Communication gateway LUF

Description	Reference
Fipio / Modbus gateway	LUF9
Profibus DP / Modbus gateway	LUF7
DeviceNet / Modbus gateway	LUF9

Description

Front panel of the product

- ① LED indicating :
 - communication status of the Modbus serial links,
 - gateway status,
 - communication status of the Fipio, Profibus DP or DeviceNet bus.
- ② Connectors for connection to Fipio, Profibus DP or DeviceNet buses.

Underside of product

- ③ RJ45 connector for connection of the Modbus serial link
- ④ RJ45 connector for link to a PC
- ⑤ 24 V power supply

Software set-up

For the Fipio bus, software set-up of the gateway is performed using either PL7 Micro/Junior/Pro software or ABC Configurator software.

For the Profibus DP and DeviceNet buses, software set-up is performed using ABC Configurator.

This software is included in the Ultra user's manual.

(1) Connection kit for PowerSuite software workshop.

Schemes:
page A4/70

A4/30

Life Is On

Schneider
Electric

TeSys Control

Ultra motor starters - Current limiter blocks - Accessories

Product references

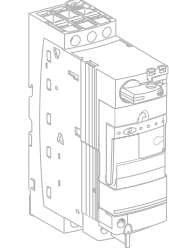

LU9SP0

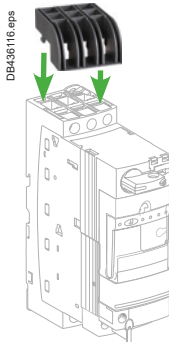

LU9ET1S



LU9ET1S



LA9LB920



LU9SP0

Short-circuit current limiter block

To be connected in series and upstream of a Ultra starter-controller. It increases its ability to withstand the short circuit current from 50 kA to 100 or 130 kA under 400 V.

Principle: under the action of a short-circuit, the opening of two contacts of each phase of the limiter creates a resistive arc. The current then decreases to a value tolerable by a Ultra power base.

Limiter blocks and accessories

Description	Breaking capacity Iq (kA)		Ie (A)	Ith (A)	Mounting	Unit reference
	≤ 440 V	690 V				
Limiter-disconnector (1 x LU9SP0 cartridge supplied)	130	70	-	32	Direct on power base up to 15 kW/32 A	LA9LB920 ⁽¹⁾
Limiter limiter cartridge for LU9SP0	100	35	32	63	Separate	LU9LB920 ⁽²⁾
Limiter-disconnector for LA9LB920	130	70	-	-	Limiter-disconnector	LU9LFB1

⁽¹⁾ Must be connected to one power base only.

⁽²⁾ Can be connected to multiple Ultra power bases in parallel with limitation :

■ Total Ith max 63 A

■ Total nominal current (Ie) 32 A from motor with simultaneous start (LA9LB920 could not withstand higher inrush peak current)

Phase barrier

Ensures a complementary electrical insulation between phases.

690 V AC network: compulsory.

440 V AC network: compulsory when assembling a UL508 type E compliant motor starter (Self Protected Starter).

Description	Use	Mounting	Reference
Phase separator	LUB or LU2B 12 or 120 LUB or LU2B 32 or 320 LU9LFB1	Live terminals L1, L2, L3	LU9SP0

Clip-in labels

Can be clipped on any Ultra power base, on LU6MB0●● inverter block, and Linergy HK busbar system.

Marking accessory

Description	Sold by lot of	Reference per unit
Clip-in label 8 x 18 mm	100	LAD90

Safety-chain identification - Red label

The red sticker is dedicated to Ultra LUCA, LUCB, LUCC, LUCL and LUCL control units.

Description	Reference per unit
Retrofit safety-chain identification sticker	LU9ET1S

TeSys Control

Ultra motor starters - Rotary handles

Product references

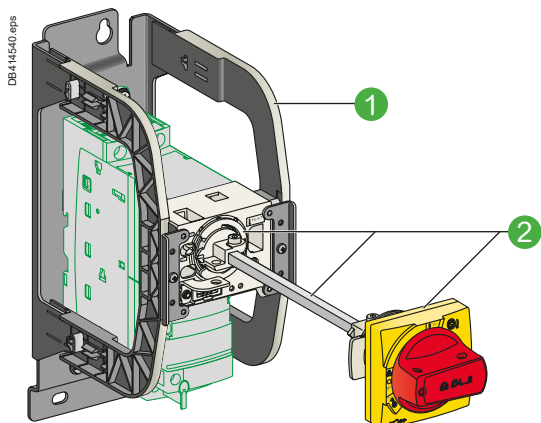

LU9APN21 mounting kit

Extended rotary handle

Allows a circuit breaker or a Ultra starter-controller installed in back of an enclosure to be operated from the front panel.

The rotary handle can be black or red/yellow, IP54 or IP65. It includes a function for locking the circuit breaker or the starter in the O (OFF) or I (ON) position (depending on the type of rotary handle) by means of up to 3 padlocks with a shank diameter of 4 to 8 mm.

The extension shaft must be adjusted to the depth of the enclosure.

The IP54 rotary handle is fixed with a nut (Ø22) to make it easier to assemble.

Mounting kit

① Ultra power base bracket; its horseshoe shaped sides hold the rotary mechanism facing the original handle.

② Mechanism, shaft and handle; the shaft enters the handle attached to the door during closing.

Long shaft

■ to be cut to the required length. Equipped with a connection endpiece.

Shaft support plate for deep enclosure

■ Provides horizontal guiding of the shaft, when the door is open.

Spacer base (retrofit accessory)

■ Fixed on a side of the box, for heightening an GVAP●●● handle.

Handle

■ Delivered as a single unit, to be fitted on a side of the enclosure.

Note: references below are suitable for Ultra power bases after 2004.

"Laser Square" Tool

■ On the principle of an angle extended with a laser beam, the "Laser Square" facilitates tracing the piercing marks on the door or the sides of an enclosure.

"Safety" stickers

■ Marking: Electrical hazard, etc.

Ultra motor starters



GVAPA1 long shaft

PB100291 eps



GVAPK12 shaft support plate for deep enclosure

PB121242 eps

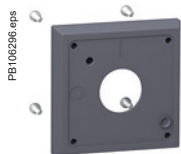

GVAPP1 spacer base (retrofit accessory)

PB100296 eps



GVAPR54 red handle, IP 54

PB100289 eps

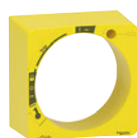

GVAPYPHP external handle protection frame



GVAPL01 "Laser square" plotting tool

PB100297 eps

Description	Tripping indication	Reference
Mounting kit	Black handle, with error status, IP54	● LU9APN21
	Red handle, with error status, IP54	● LU9APN22
	Red handle, without error status, IP65	- LU9APN24
Separate elements	Long shaft = 315 mm	- GVAPA1
	Shaft (≥ 300 mm) support plate for deep enclosure	- GVAPK12
	Spacer base	- GVAPP1
	Black handle, IP54	● GVAPB54
	Red handle, IP54	● GVAPR54
	Red handle, IP65	● GVAPR65
Tool	"Laser square" plotting tool	GVAPL01
"Safety" stickers	German (x10)	GVAPSDE
	Chinese (x10)	GVAPSCN
	Portuguese (x10)	GVAPSPT
	Italian (x10)	GVAPSIT
External handle protection frame for U	Yellow frame	GVAPYPHP
	Black frame	GVAPBPHP

TeSys Control

Ultra motor starters - Handle mounting kit for MCC drawers

Product references



MCC drawers (Motor Control Center)

The drawers are composed of:

- a fixed part, in the frame of the panel,
- a fully withdrawable part, integrating the protection, control and automation components.

With a height of 3/4/6/8/12/18/24/36 modules, they allow the assembling of motor protection/control feeders:

- Direct, one direction of rotation
- Direct, 2 directions of rotation
- Star-delta
- Dahlander (2 speeds)
- 2-speed, separate winding
- Motor drives from 0 to 500 kW
- Soft starters of 0 to 75 kW.

Ultra
motor
starters

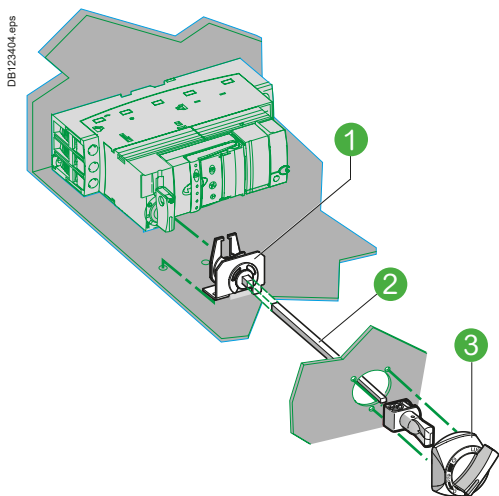

Mounting kit and handle for MCC drawer

Together, this provides manual control of a Ultra starter-controller from the front face of the drawer.

As the clamping part on top of Ultra control pad is open, the kit may be used on Ultra power bases before 2005.

Mounting kit + small handle

Description	Item	Reference
Handle with mounting kit for MCC drawer	1 + 2 + 3	LU9AP20



TeSys Control

Ultra motor starters - Use with soft starter / Variable Speed Drive - LUCL control module

Product references

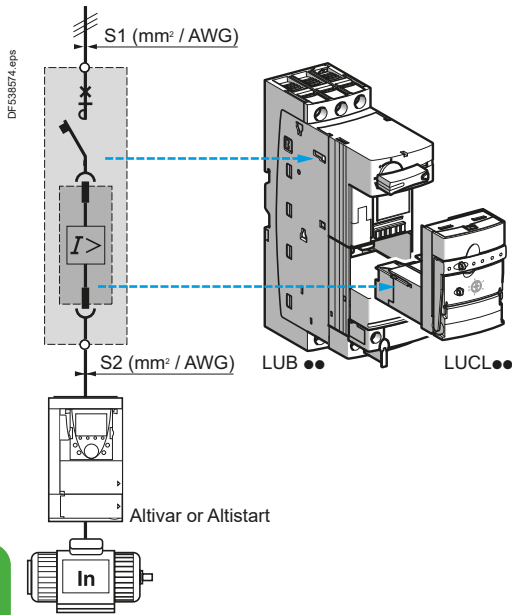

Ultra motor starters



PB12873 eps



Introduction

When installed upstream of a variable speed controller or soft start unit, control unit LUCL●●, used in conjunction with an LUB12 or LUB32 power base, provides:

- isolation,
 - short-circuit protection of the motor starter.
- (variable speed controller-based or soft start unit-based motor starters).

Note: control unit LUCL, when used in conjunction with power base LUB12 or LUB32, conforms to standard IEC 60947-6-2.

Installation regulations

When the length of the cable between the Ultra starter and the variable speed controller is more than 1.5 m, the c.s.a. of the cable between the variable speed controller and the Ultra starter (S2) must be equal to the c.s.a. of the cable upstream of Ultra (S1).

Description of LUCL magnetic control unit

- ① Extraction and locking handle
- ② Sealing of locking handle
- ③ Dial for magnetic adjustment of motor In
- ④ Locking of settings by sealing the transparent cover

References

Description	Line current of the variable speed controller or soft start unit	Reference ⁽¹⁾
	A	
Magnetic control unit	0.15...0.6	LUCLX6●●
	0.35...1.4	LUCL1X●●
	1.25...5	LUCL05●●
	3...12	LUCL12●●
	4.5...18	LUCL18●●
	8...32	LUCL32●●

⁽¹⁾ Standard control circuit voltage:

Volts	24	48...72	110...240
---	BL ^{(2) (3)}	—	—
~	B	—	—
--- or ~	—	ES ⁽⁴⁾	FU ⁽⁵⁾

Please check the availability of your variant in the index page A4/42. The SEARCH function of your viewer can be used.

⁽²⁾ Voltage code to be used for a starter-controller with communication module.

⁽³⁾ d.c. voltage with maximum ripple of ±10 %.

⁽⁴⁾ ---: 48...72 V, ~: 48 V.

⁽⁵⁾ ---: 110...220 V, ~: 110...240 V.

Control unit and associated power base selection						
Functions provided	Maximum motor power ratings 50/60 Hz			Power base reference	Control unit reference	Line current
	< 400/415 V	500 V	690 V			
	KW	KW	KW			
■ Short-circuit protection	0.09	–	–	LUB12 or LUB32	LUCLX6●●	0.15...0.6
■ Manual reset	0.25	–	–	LUB12 or LUB32	LUCL1X●●	0.35...1.4
	1.5	2.2	3	LUB12 or LUB32	LUCL05●●	1.25...5
	5.5	5.5	9	LUB12 or LUB32	LUCL12●●	3...12
	7.5	9	15	LUB32	LUCL18●●	4.5...18
	15	15	18.5	LUB32	LUCL32●●	8...32

Operating characteristics						
Control units	Standard		Advanced			Multifunction
	LUCA	LUCB	LUC	LUCD	LUCL	LUCM
Thermal overload protection	Integrated function					Non integrated function
Over current protection	14.2 x the setting current					3 to 17 x the setting current
Short-circuit protection	13 x I _r max (max current setting)					
Protection against phase loss	Integrated function					Non integrated function
Protection against phase imbalance	Integrated function					Non integrated function
Earth fault protection (equipment protection only)	Integrated function					Non integrated function
Tripping class	10	10	20	20	20	5...30
Motor type	3-phase		Single-phase	3-phase	Single-phase and 3-phase	
Thermal overload test function	Integrated function					Non integrated function
Overtorque	Integrated function					Non integrated function
No-load running	Integrated function					Non integrated function
Long starting time	Integrated function					Non integrated function
Reset method	Manual	Integrated function				Parameters can be set
	Automatic or remote	With function module, or parameters can be set via the bus with a communication module (see page 24614/2).			LUCL	Parameters can be set via the bus with a communication module (see page 24614/2).

Integrated function
 Non integrated function
 Function provided with accessory

Compatibility			
Compatibility of control unit LUCL●● with	References	Functions	
The controller	No	LUTM	Controller (without thermal overload protection)
Add-on contact blocks with fault signalling and auxiliary contacts	Yes	LUA1C11	Add-on contact blocks with fault signalling (1 N/O + 1 N/C)
		LUA1C20	Add-on contact blocks with fault signalling (2 N/O)
		LUFN20	Auxiliary contacts (2 N/O)
		LUFN11	Auxiliary contacts (1 N/O + 1 N/C)
		LUFN02	Auxiliary contacts (2 N/C)
Communication modules	Yes	ASILUFC5 and ASILUFC51	AS-Interface communication modules
		LUFC00	Parallel wiring module
		LULC07	Profibus DP communication module (1 output/2 inputs)
		LULC08	CANopen communication module (1 output/2 inputs)
		LULC09	DeviceNet communication module (1 output/2 inputs)
		LULC15	Advantys STB communication module (1 output/2 inputs)
		LULC033	Modbus communication module (1 output/2 inputs)
Function modules	No	LUFW10	Alarm function module
		LUFDH11	Thermal overload signalling module with manual reset
		LUFDA01	Thermal overload signalling module with automatic or remote reset (1 N/C)
		LUFDA10	Thermal overload signalling module with automatic or remote reset (1 N/O)
		LUFV2	Motor load indication module

TeSys Control

Ultra motor starters - with Altistart U01 soft starter

Introduction

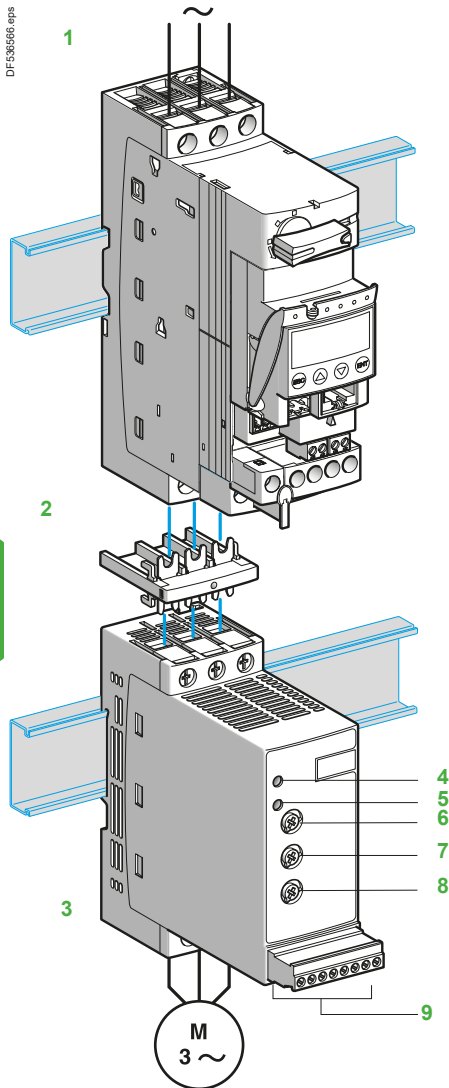

Introduction

The Altistart U01 is a soft start/soft stop unit for asynchronous motors. It is designed primarily for combinations with Ultra controller-starters.

When combined with a Ultra 1 controller by means of a connector 2, the Altistart U01 3 is a power option which provides the "Soft start/soft stop" function. The result is a unique, innovative motor starter.

Using the Altistart U01 starter enhances the starting performance of asynchronous motors by allowing them to start gradually, smoothly and in a controlled manner. It prevents mechanical shocks, which lead to wear and tear, and limits the amount of maintenance work and production downtime.

The Altistart U01 limits the starting torque and current peaks on starting, on machines which do not require a high starting torque.

The Altistart U01 is designed for the following simple applications:

- Conveyors
- Conveyor belts
- Pumps
- Fans
- Compressors
- Automatic doors and gates
- Small cranes
- Belt-driven machines, etc.

The Altistart U01 is compact and easy to install. It complies with standards IEC/EN 60947-4-2, carries UL, CSA, C-Tick, CCC certifications and CE marking.

■ ATSU01N2●●LT soft start/soft stop units

- Control two phases of the motor power supply to limit the starting current and for deceleration
- Internal bypass relay
- Motor power ratings ranging from 0.75 kW to 15 kW
- Motor supply voltages ranging from 200 V to 480 V, 50/60 Hz.

An external power supply is required for controlling the starter.

Description

- Altistart U01 soft start/soft stop units are equipped with:
 - A potentiometer for setting the starting time 6
 - A potentiometer for setting the deceleration time 8
 - A potentiometer for adjusting the start voltage threshold according to the motor load 7
 - 1 green LED 4 to indicate that the unit is switched on
 - 1 yellow LED 5 to indicate that the motor is powered at nominal voltage, if it is connected to the starter
 - A connector 9:
 - 2 logic inputs for Run/Stop commands
 - 1 logic input for the BOOST function
 - 1 logic output to indicate the end of starting
 - 1 relay output to indicate the starter has a power supply fault or the motor has reached a standstill at the end of the deceleration stage

ATSU01N2●●●LT soft start unit functions

■ 2-wire control

The run and stop commands are controlled by a single logic input. State 1 of logic input LI2 controls starting and state 0 controls stopping.

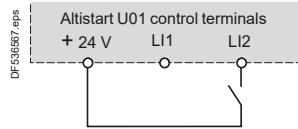

Wiring diagram for 2-wire control

■ 3-wire control

The run and stop commands are controlled by 2 different logic inputs.

Stopping is achieved when logic input LI1 opens (state 0).

The pulse on input LI2 is stored until input LI1 opens.

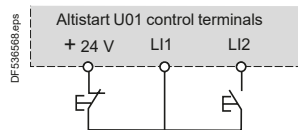

Wiring diagram for 3-wire control

■ Starting time

Controlling the starting time means that the time of the voltage ramp applied to the motor can be adjusted to obtain a gradual starting time, dependent on the motor load.

■ Voltage boost function via logic input

Activating the BOOST logic input enables the function for supplying a starting overtorque capable of overcoming any mechanical friction.

When the input is at state 1, the function is active (input connected to the + 24 V) and the starter applies a fixed voltage to the motor for a limited time before starting.

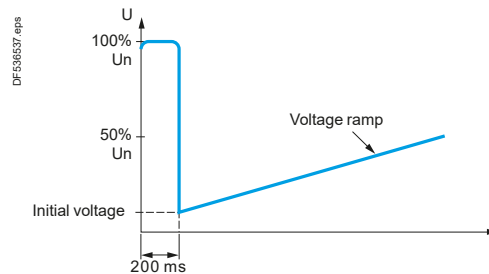

Application of a voltage boost equal to 100% of the nominal motor voltage

■ End of starting

○ application function for logic output LO1

ATSU01N2●●●LT soft start/soft stop units are equipped with an open collector logic output LO, which indicates the end of starting when the motor has reached nominal speed.

TeSys Control

Altistart U01 soft starter

Product references

109690SE.eps



ATSU01N222LT

Ultra motor starters

DF538570.eps

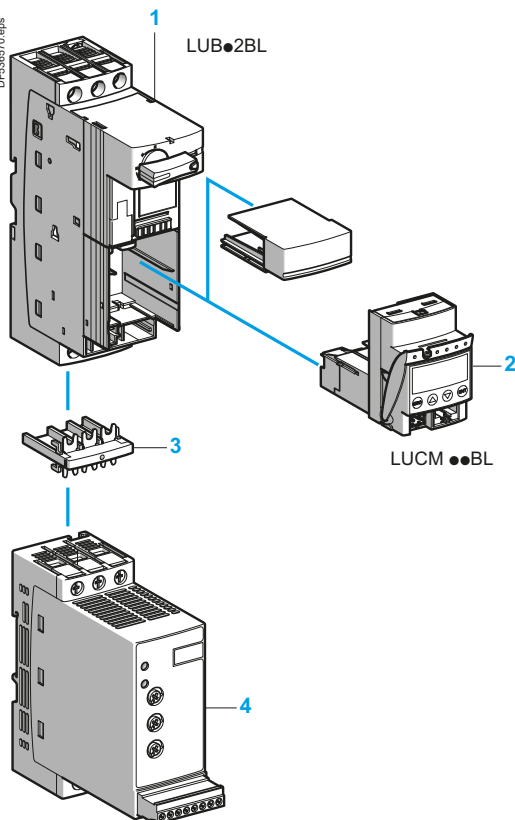

ATSU 01N2●●LT

Soft start/soft stop units for 0.75 to 15 kW motors (can be combined with the Ultra starter)

Motor				Starter	
Motor power ⁽¹⁾				Nominal current	Reference
230 V		400 V	460 V	A	
kW	HP	kW	HP		
3-phase supply voltage: 200...480 V 50/60 Hz					
0.75	1	1.5	2	6	ATSU01N206LT
1.1	1.5	2.2	3		
1.5	2	–	5	9	ATSU01N209LT
–	–	4	–		
2.2	3	5.5	7.5	12	ATSU01N212LT
3	–	–	–		
4	5	7.5	10	22	ATSU01N222LT
5.5	7.5	11	15		
7.5	10	15	20	32	ATSU01N232LT

Accessories

Description	Used for starter	Reference
Power connector between ATSU01N2●●LT and U	ATSU01N2●●LT	VW3G4104

Ultra starter and soft start unit combinations

Numerous possibilities for combinations and options are offered. Please consult the "Ultra Starters-open version" specialist catalogue.

Motor power	Soft starter			U		
	230 V	400 V	460 V	Power base	Control unit ⁽²⁾	
Voltage	kW/HP	kW	HP			
0.75/1	1.5	2	–	ATSU01N206LT	LUB12	LUC●05BL
1.1/1.5	2.2/3	3	–	ATSU01N206LT	LUB12	LUC●12BL
1.5/2	–	–	–	ATSU01N209LT	LUB12	LUC●12BL
–	4	5	–	ATSU01N209LT	LUB12	LUC●12BL
2.2/3	–	–	–	ATSU01N212LT	LUB12	LUC●12BL
3/–	5.5	7.5	–	ATSU01N212LT	LUB32	LUC●18BL
4/5	7.5	10	–	ATSU01N222LT	LUB32	LUC●18BL
5.5/7.5	11	15	–	ATSU01N222LT	LUB32	LUC●32BL
7.5/10	15	20	–	ATSU01N232LT	LUB32	LUC●32BL

Example of a starter-motor combination with:

- 1 non-reversing power base for DOL starting (LUB●2BL)
- 2 control unit (LUCM●●BL)
- 3 power connector (VW3G4104)
- 4 Altistart U01 soft start/soft stop unit (ATSU01N2●●LT)

⁽¹⁾ Standard motor power ratings, HP power ratings indicated according to standard UL508.

⁽²⁾ Depending on the configuration of the chosen Ultra starter, replace the ● with A for standard, B for expandable, and M for multifunction.

TeSys Control

Ultra motor starters - Association with Soft starters / Variable speed controllers

Product references

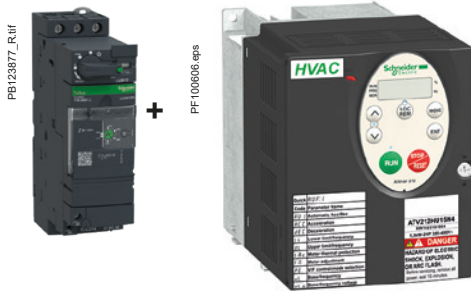

Soft starter coordination

The standard defines tests at different levels of current; the purpose of these tests is to place the equipment in extreme conditions.

The standard defines 2 types of coordination, according to the condition of the components after testing: type 1 and type 2.

Type 1 coordination requires that in a short-circuit condition, the contactor or starter must not present any danger to personnel or installations and must not be able to resume operation without repair or the replacement of parts.

The product combinations given below provide type 1 coordination

Soft start-soft stop unit/ Ultra starter controller combination with magnetic protection

Ultra / Altistart 48: type 1 coordination

Power 400 V (kW)	Ultra references (protection + power switching)	Soft starter reference	
		Class 10	Class 20
5.5	LUB32 + LUCL32 or LUCL18	–	ATS48D17
7.5	LUB32 + LUCL32	ATS48D17	ATS48D22
11	LUB32 + LUCL32	ATS48D22	ATS48D32
15	LUB32 + LUCL32	ATS48D32	ATS48D38

Variable speed controller/ Ultra starter controller combination with magnetic protection

Ultra / Altivar 212 UL Type 1/IP 20

Power 400 V (kW)	Ultra references (protection + power switching)	Variable speed controller reference	
0.75	LUB12 + LUCL05	ATV212H075N4	ATV212HU15N4
2.2	LUB12 + LUCL12	ATV212HU22N4	
3	LUB12 + LUCL12	ATV212HU30N4	
4	LUB12 + LUCL12	ATV212HU40N4	
5.5	LUB32 + LUCL32 or LUCL18	ATV212HU55N4	
7.5	LUB32 + LUCL32 or LUCL18	ATV212HU75N4	
11	LUB32 + LUCL32	ATV212HD11N4	
15	LUB32 + LUCL32	ATV212HD15N4	

Ultra / Altivar 212 IP 54

Power 400 V (kW)	Ultra references (protection + power switching)	Variable speed controller reference	
0.75	LUB12 + LUCL05	ATV212W075N4	
1.5	LUB12 + LUCL12 or LUCL05	ATV212WU15N4	
2.2	LUB12 + LUCL12	ATV212WU22N4	
3	LUB12 + LUCL12	ATV212WU30N4	
4	LUB12 + LUCL12	ATV212WU40N4	
5.5	LUB32 + LUCL32 or LUCL18	ATV212WU55N4	
7.5	LUB32 + LUCL32 or LUCL18	ATV212WU75N4	
11	LUB32 + LUCL32	ATV212WD11N4	
15	LUB32 + LUCL32	ATV212WD15N4	

Ultra
motor
starters

TeSys Control

Ultra motor starters - Association with Soft starters / Variable speed controllers

Products references

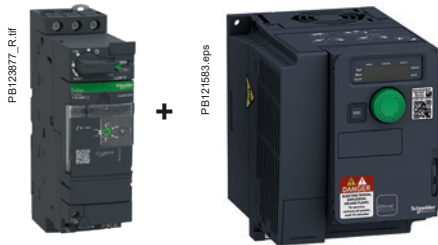

Ultra motor starters



Variable speed controller/Ultra starter controller combination with magnetic protection (continued)

Ultra / Altivar 320

Power 400 V (kW)	Ultra references (protection + power switching)	Variable speed controller reference
0.37	LUB12 + LUCL05	ATV320U04N4C
0.55	LUB12 + LUCL05	ATV320U06N4C
0.75	LUB12 + LUCL05	ATV320U07N4C
1.1	LUB12 + LUCL12	ATV320U11N4C
1.5	LUB12 + LUCL12	ATV320U15N4C
2.2	LUB12 + LUCL12	ATV320U22N4C
3	LUB32 + LUCL18	ATV320U30N4C
4	LUB32 + LUCL18	ATV320U40N4C
5.5	LUB32 + LUCL32	ATV320U55N4C
7.5	LUB32 + LUCL32	ATV320U75N4C

Ultra / Altivar 630

Power 400V (kW)	Ultra references (protection + power switching)	Variable speed controller reference
0.75	LUB12 + LUCL05	ATV630U07N4
1.5	LUB12 + LUCL12	ATV630U15N4
2.2	LUB12 + LUCL12	ATV630U22N4
3	LUB32 + LUCL18	ATV630U30N4
4	LUB32 + LUCL18	ATV630U40N4
5.5	LUB32 + LUCL32	ATV630U55N4
7.5	LUB32 + LUCL32	ATV630U75N4

TeSys Control

Ultra motor starters

Product references

ASILUFC5	LU9R30	LUCB12FU	LUCD32FU
ASILUFC51	LU9RCD03	LUCB18B	LUCD38BL
GV1G10	LU9RCD10	LUCB18BL	LUCD38FU
GVAPA1	LU9RCD50	LUCB18ES	LUCDT1BL
GVAPA2	LU9RDD03	LUCB18FU	LUCDX6BL
GVAPB54S	LU9RDD30	LUCB1XB	LUCDX6FU
GVAPK12	LU9RFL15	LUCB1XBL	LUCL05B
GVAPL01	LU9RPB010	LUCB1XES	LUCL05BL
GVAPP1	LU9RPB100	LUCB1XFU	LUCL05ES
GVAPR65S	LU9RPB400	LUCB32B	LUCL05FU
LA9LB920	LU9SP0	LUCB32BL	LUCL12B
LU2B12B	LUA1C11	LUCB32ES	LUCL12BL
LU2B12BL	LUA1C20	LUCB32FU	LUCL12ES
LU2B12ES	LUA8E20	LUCB38BL	LUCL12FU
LU2B12FU	LUALB1	LUCB38FU	LUCL18B
LU2B32B	LUALF1	LUCBT1BL	LUCL18BL
LU2B32BL	LUB12	LUCBX6B	LUCL18ES
LU2B32ES	LUB120	LUCBX6BL	LUCL18FU
LU2B32FU	LUB32	LUCBX6FU	LUCL1XB
LU2B38BL	LUB320	LUCC05B	LUCL1XBL
LU2B38FU	LUB32NR	LUCC05BL	LUCL1XFU
LU2BA0BL	LUB38	LUCC05ES	LUCL32B
LU2BA0ES	LUB380	LUCC05FU	LUCL32BL
LU2BB0BL	LUCA05B	LUCC12B	LUCL32FU
LU2MB0B	LUCA05BL	LUCC12BL	LUCL38BL
LU2MB0BL	LUCA05ES	LUCC12ES	LUCL38FU
LU2MB0ES	LUCA05FU	LUCC12FU	LUCLX6BL
LU2MB0FU	LUCA12B	LUCC18BL	LUCM05BL
LU6MB0B	LUCA12BL	LUCC18FU	LUCM12BL
LU6MB0BL	LUCA12ES	LUCC1XB	LUCM18BL
LU6MB0ES	LUCA12FU	LUCC1XBL	LUCM1XBL
LU6MB0FU	LUCA18B	LUCC1XES	LUCM32BL
LU9AD7	LUCA18BL	LUCC1XFU	LUCMT1BL
LU9AP00	LUCA18ES	LUCC32B	LUCMX6BL
LU9AP11	LUCA18FU	LUCC32BL	LUCF00
LU9AP20	LUCA1XB	LUCC32FU	LUFDA01
LU9APN21	LUCA1XBL	LUCCX6B	LUFDA10
LU9APN22	LUCA1XES	LUCCX6BL	LUFDH11
LU9APN24	LUCA1XFU	LUCCX6FU	LUFN02
LU9BN11	LUCA32B	LUCD05B	LUFN11
LU9BN11C	LUCA32BL	LUCD05BL	LUFN20
LU9BN11L	LUCA32ES	LUCD05ES	LUFN1
LU9C1	LUCA32FU	LUCD05FU	LUFN7
LU9C2	LUCA38BL	LUCD12B	LUFN9
LU9ET1S	LUCA38FU	LUCD12BL	LUFV2
LU9G02	LUCAX6B	LUCD12ES	LUFW10
LU9G03	LUCAX6BL	LUCD12FU	LULC031
LU9GC3	LUCAX6ES	LUCD18BL	LULC033
LU9GC7	LUCAX6FU	LUCD18FU	LULC07
LU9M1	LUCB05B	LUCD1XB	LULC08
LU9MR1	LUCB05BL	LUCD1XBL	LULC09
LU9MR1C	LUCB05ES	LUCD1XES	LULC15
LU9MRC	LUCB05FU	LUCD1XFU	
LU9MRL	LUCB12B	LUCD32B	
LU9R03	LUCB12BL	LUCD32BL	
LU9R10	LUCB12ES	LUCD32ES	

Ultra
motor
starters

This document is current.  Click on the product reference to get the most recent availability status (hyperlink to [se.com](https://www.se.com) product datasheet).
If your product variant is no longer available, please consult your distributor or regional sales office.