

# S-Flex™ 212

## Adjustable Speed Enclosed Drive

### Instruction Bulletin

30072-451-83  
Rev. 07, 10/2018

Retain for future use.



 **SQUARE D**™

by Schneider Electric



# Table of Contents

- Hazard Categories and Special Symbols..... 6
- Please Note ..... 6
- SECTION 1:INTRODUCTION AND TECHNICAL CHARACTERISTICS ..... 7**
  - Product Overview ..... 7
  - About This Document ..... 7
  - Terminology ..... 7
  - Before You Begin ..... 8
  - Catalog Number Description ..... 10
  - Nameplate Identification ..... 12
  - Technical Characteristics ..... 12
    - Short Circuit Ratings ..... 14
    - Input Current Ratings ..... 14
  - Technical Specifications ..... 14
- SECTION 2:RECEIVING, HANDLING, AND STORING ..... 16**
  - Receiving and Preliminary Inspection ..... 16
    - Storing the Equipment ..... 16
    - Unpacking the Enclosed Drive ..... 17
    - Before Installing the Enclosed Drive ..... 17
    - Handling the Enclosed Drive ..... 17
- SECTION 3:INSTALLATION AND START-UP ..... 19**
  - Installation Guidelines ..... 19
  - Weights ..... 19
  - Center of Gravity ..... 20
  - Dimensions for Wall or Panel Mounting ..... 21
  - Mounting Requirements ..... 45
  - Mounting on an EZM Mounting Channel (Type 1 Only) ..... 46
  - Seismic Qualification Mounting Criteria ..... 47
  - Electrical Installation ..... 48
    - General Wiring Practices ..... 48
    - Input Power ..... 49
    - Branch Circuit Connections ..... 49
    - Input Wiring ..... 49
    - Grounding ..... 50
    - Connection to Ungrounded or High-Resistance Grounded Systems ..... 51
    - Wiring and Electromagnetic Compatibility ..... 52
    - Output Wiring ..... 54
    - DC Bus Voltage Measurement Procedure ..... 56
  - Wire Routing and Interconnection ..... 57
    - Wire Class ..... 57

Noise Class .....	57
Voltage Class .....	57
Wiring Methods .....	58
Component Locations .....	60
Power Wiring .....	66
Control Wiring .....	70
Keypad Operation .....	73
Integrated Keypad .....	73
Graphic Keypad Option (D07) .....	75
Programming Access with Type 3R Enclosure .....	76
Initial Start-up Procedure .....	78
Checking the Enclosure Components and Connections .....	79
Adjusting Bypass Motor Overload Protection .....	80
Checking and Correcting Motor Rotation .....	81
Checking and Correcting Motor Rotation in Bypass Mode .....	82
Checking the Graphic Terminal Settings .....	82
Adjusting Mag-Gard or PowerPact Magnetic Trip Setting .....	84
Fusible Disconnect .....	85
Overload Relay Adjustment .....	86
<b>SECTION 4: OPERATION</b> .....	<b>87</b>
Programming the Power Converter .....	87
Power Circuit Y with Full Voltage Bypass .....	89
Power Circuit W Without Bypass .....	89
Operator Controls – General Arrangement and Operation .....	89
AFC Operation .....	90
Non-Bypass Units (Power Circuit W) .....	90
Bypass Units (Power Circuit Y, Series D) .....	90
Bypass Units (Power Circuit Y, Series E) .....	91
UL® Type 3R Operation .....	91
Freeze/Firestat Interlocks (If Used) .....	91
Pilot Lights .....	92
Auxiliary Drive Run Contact (Power Circuit W) .....	92
System Run Contact (Power Circuit Y) .....	92
Auxiliary Detected Fault Contact .....	92
Damper Control .....	92
Smoke Purge Function (Fireman's Override) .....	93
Options .....	94
MOD A06—BACnet .....	94
MOD A07—Drive Input Disconnect Switch .....	94
MOD B06—LonWorks .....	94
MOD B07—Line Contactor .....	94
MOD C06—Metasys N2 .....	94
MOD D06—Apogee P1 .....	94
MOD D07—Remote Graphic Keypad .....	94
MOD K07—50 °C Operation .....	94
MOD N06—Modbus .....	94
MOD S07—Seismic Qualified .....	94
MOD T07—cUL Option .....	95
MOD X07—Line Reactor .....	95
Wiring Diagrams .....	96

---

<b>SECTION 5:PROPORTIONAL–INTEGRAL–DERIVATIVE CONTROL</b> .....	101
Introduction .....	102
Scaling of PID Parameters .....	103
PID Tuning .....	104
Setting PID Control .....	106
Drive Configuration via Integrated or Graphic Keypad .....	106
Control Loop Configuration .....	107
Control Loop Configuration .....	108
Sleep/Wake Operation .....	108
PID Control Waiting Time .....	109
Attain Speed Relay .....	109
Control Wiring .....	109
Application Notes .....	111
Programming the PID Internal Setpoint with the Keypad .....	111
<b>SECTION 6:MAINTENANCE AND SUPPORT</b> .....	112
Precautions .....	112
Diagnostic Codes .....	115
External Signs of Damage .....	115
Preventive Maintenance .....	115
Inspection .....	116
Maintenance after a Downstream Fault Has Occurred .....	116
Circuit Breaker Maintenance .....	117
Servicing the Front Fan Filters (without Rain Hood) .....	117
Servicing the Exhaust Fan Filter .....	119
Replacing the Door Fans .....	121
Technical Support .....	123
Schneider Electric Services (On-Site) .....	123
Schneider Electric Customer Training .....	123
Product Literature .....	123
S-Flex 212 Troubleshooting Sheet .....	124
Renewable Parts .....	125

## Hazard Categories and Special Symbols

Read these instructions carefully and look at the equipment to become familiar with the device before trying to install, operate, service, or maintain it. The following special messages may appear throughout this bulletin or on the equipment to warn of hazards or to call attention to information that clarifies or simplifies a procedure.



The addition of either symbol to a “Danger” or “Warning” safety label indicates that an electrical hazard exists which will result in personal injury if the instructions are not followed.



This is the safety alert symbol. It is used to alert you to personal injury hazards. Obey all safety messages that follow this symbol to avoid possible injury or death.

### **⚠ DANGER**

**DANGER** indicates a hazardous situation which, if not avoided, **will result in** death or serious injury.

### **⚠ WARNING**

**WARNING** indicates a hazardous situation which, if not avoided, **can result in** death or serious injury.

### **⚠ CAUTION**

**CAUTION** indicates a hazardous situation which, if not avoided, **can result in** minor or moderate injury.

### **NOTICE**

**NOTICE** is used to address practices not related to physical injury. The safety alert symbol is not used with this signal word.

**NOTE:** Provides additional information to clarify or simplify a procedure.

### **Please Note**

Electrical equipment should be installed, operated, serviced, and maintained only by qualified personnel. No responsibility is assumed by Schneider Electric for any consequences arising out of the use of this material.

# Section 1— Introduction and Technical Characteristics

## Product Overview

The S-Flex™ 212 enclosed drive is a full-featured adjustable speed package solution for variable torque applications. The S-Flex enclosed drive is a bypass package that includes an Altivar™ 212 adjustable speed drive on a wall-mountable back plane with pre-packaged model number options for both power and control functions. The following features are available for the standard bypass package:

- AFC-Off-Bypass selector switch in Series D
- Hand-Off-Auto and AFC-Bypass in Series E
- Local/Remote configurable on enclosed drive
- Power On red LED
- Bypass Run green LED
- Freeze/Firestat interlock
- Form C AFC detected fault contact
- Modbus™ RJ-45 communication port
- Smoke purge and damper control relays
- Circuit breaker disconnect
- Optional line disconnect switch or line contactor
- Optional full text keypad
- Optional non-bypass power circuit

## About This Document

This instruction bulletin contains installation, programming, and maintenance instructions for the S-Flex enclosed drives. This revision adds information about Series E, S-Flex 212 enclosed drives with full voltage bypass (power circuit Y). Series E includes new control architecture for the Smoke Purge function (Fireman's Override). The following documentation is also provided with the drive:

- *Altivar 212 Installation Guide*, S1A53832
- *Altivar 212 Programming and Operation Guide*, S1A53838
- *Altivar 212 Quick Start Guide*, S1A53825
- *Handling, Installation, Operation, and Maintenance of Electrical Control Equipment*, Instruction Bulletin 30072-200-50

**NOTE:** To replace missing documents, contact Schneider Electric or download them from the Technical Library at [www.Schneider-Electric.com](http://www.Schneider-Electric.com).

## Terminology

The following terminology is used throughout this instruction bulletin to distinguish between the S-Flex 212 enclosed drives and the Altivar 212 components.

- **Enclosed drive** refers to the S-Flex 212 package.
- **Drive or power converter** are used to describe the Altivar 212 component.

## Before You Begin

**⚠ WARNING:** This product can expose you to chemicals including lead and lead compounds, which are known to the State of California to cause cancer and birth defects or other reproductive harm. For more information go to [www.P65Warnings.ca.gov](http://www.P65Warnings.ca.gov).

### ⚠ DANGER

#### HAZARD OF ELECTRIC SHOCK, EXPLOSION, OR ARC FLASH

- Read and understand this manual before installing or operating the S-Flex enclosed drive. Installation, adjustment, repair, and maintenance must be performed by qualified personnel.
- The user is responsible for compliance with all national and local electrical code requirements with respect to grounding of all equipment.
- Many parts of the drive, including the printed circuit boards, operate at the line voltage. **DO NOT TOUCH.** Use only electrically insulated tools.
- Some terminals have voltage on them when the disconnect is open.
- **DO NOT** short across terminals PA/+ and PC/– or across the DC bus capacitors.
- Before servicing the enclosed drive:
  - Disconnect all power including external control power that may be present.
  - Place a “DO NOT TURN ON” label on all power disconnects.
  - Lock all power disconnects in the open position.
  - **WAIT 15 MINUTES** to allow the DC bus capacitors to discharge. Then follow the “DC Bus Voltage Measurement Procedure” on page 56 to verify that the DC voltage is less than 42 V. The drive LED is not an indicator of the absence of DC bus voltage.
- Install and close all covers and doors before applying power or starting and stopping the enclosed drive.

**Failure to follow these instructions will result in death or serious injury.**

### ⚠ DANGER

#### HAZARD OF ELECTRIC SHOCK, EXPLOSION, OR ARC FLASH

For Type 1, 460 V units and all Type 12 and 3R units:

- Apply appropriate personal protective equipment (PPE) and follow safe electrical work practices. See NFPA 70E®, CSA Z462, NOM-029-STPS, and other applicable regulations defining safe electrical work practices.
- This equipment must only be installed and serviced by qualified electrical personnel.
- Never operate energized switch with door open.
- Turn off switch before removing or installing fuses or making load side connections.
- Always use a properly rated voltage sensing device at all line and load fuse clips to confirm switch is off.
- Turn off power supplying switch before doing any other work on or inside switch.
- Do not use renewable link fuses in fused switches.

**Failure to follow these instructions will result in death or serious injury.**



**⚠ DANGER****HAZARD OF ELECTRIC SHOCK, EXPLOSION, OR ARC FLASH**

For Type 1 208 and 230 V units:

- Apply appropriate personal protective equipment (PPE) and follow safe electrical work practice See NFPA 70E®, CSA Z462, NOM-029-STPS, and other applicable regulations defining safe electrical work practices.
- This equipment must be installed and serviced only by qualified electrical personnel.
- Turn off all power supplying this equipment before working on or inside the equipment.
- Always use a properly rated voltage sensing device to confirm power is off.
- Replace all devices, doors, and covers before turning on power to this equipment.

**Failure to follow these instructions will result in death or serious injury.**

**⚠ DANGER****UNINTENDED EQUIPMENT OPERATION**

Before turning on the drive or upon exiting the configuration menus, ensure that the inputs assigned to the Run command are in a state that will not cause the drive to run. Otherwise, the motor can start immediately.

**Failure to follow these instructions will result in death or serious injury.**

**⚠ WARNING****LOSS OF CONTROL**

- The designer of any control scheme must consider the potential failure modes of control paths and, for certain critical control functions, provide a means to achieve a safe state during and after a path failure. Examples of critical control functions are emergency stop and overtravel stop.
- Separate or redundant control paths must be provided for critical control functions.
- System control paths may include communication links. Consideration must be given to the implications of anticipated transmission delays or failures of the link<sup>1</sup>.
- Each implementation of an S-Flex enclosed drive must be individually and thoroughly tested for proper operation before being placed into service.

**Failure to follow these instructions can result in death, serious injury, or equipment damage.**

<sup>1</sup> For additional information, refer to NEMA ICS 1.1 (latest edition), "Safety Guidelines for the Application, Installation, and Maintenance of Solid State Control" and to NEMA ICS 7.1 (latest edition), "Safety Standards for Construction and Guide for Selection, Installation and Operation of Adjustable-Speed Drive Systems."

**⚠ CAUTION****INCOMPATIBLE LINE VOLTAGE**

Before turning on and configuring the enclosed drive, ensure that the line voltage is compatible with the line voltage range specified on the enclosed drive nameplate. The enclosed drive can be damaged if the line voltage is not compatible.

**Failure to follow these instructions can result in injury or equipment damage.**

## Catalog Number Description

The catalog number, located on the nameplate attached to the S-Flex enclosed drive, is coded to describe the configuration. See Figure 1 on page 12 for an example of the S-Flex nameplate.

Use Table 2 to translate the catalog number into a description of the enclosed drive. The following example translates the catalog number shown on the nameplate in Figure 1 on page 12.

**Table 1 – Catalog Number Example: SFD212CG4YX07**

Field				
01	02	03	04	05
SFD212	C	G	4	Y
	1 hp	Type 1 General Purpose	460 Vac	Full Voltage Bypass

**Table 2 – Catalog Number Description**

Field	Digit	Characteristic	Description
01	01 – 05	Enclosed Drive Style	SFD212 = S-Flex 212 Enclosed Drive
02	06	Horsepower	C = 1 hp D = 2 hp E = 3 hp F = 5 hp G = 7.5 hp H = 10 hp J = 15 hp K = 20 hp L = 25 hp M = 30 hp N = 40 hp P = 50 hp (460 V only) Q = 60 hp (460 V only) R = 75 hp (460 V only) S = 100 hp (460 V only)

**Table 2 – Catalog Number Description** *(continued)*

Field	Digit	Characteristic	Description
03	07	Enclosure Type	A = Type 12K <sup>1, 3</sup> H = Type 3R <sup>2, 3</sup> G = Type 1 General Purpose
04	08	Voltage	2 = 208 Vac 3 = 230 Vac <sup>3</sup> 4 = 460 Vac
05	09	Power Circuit	W = Without Bypass Y = Full Voltage Bypass
06	010 – 012	Communication Set-Up Options	A06 = BACnet Card B06 = LonWorks® Card C06 = Metasys® N2 Card D06 = Apogee™ P1 Card N06 = Modbus
07	013 – 015	Miscellaneous Options	A07 = Drive Input Disconnect <sup>4</sup> B07 = Line Contactor S07 = Seismic Certification D07 = Full Text Keypad <sup>5</sup> K07 = cUL Marking (Canada) T07 = 50 °C Ambient Operation X07 = AC Line Reactor

<sup>1</sup> Industrial use, dust-tight/drip-tight

<sup>2</sup> Outdoor use

<sup>3</sup> These drives are not stocked in the warehouse.

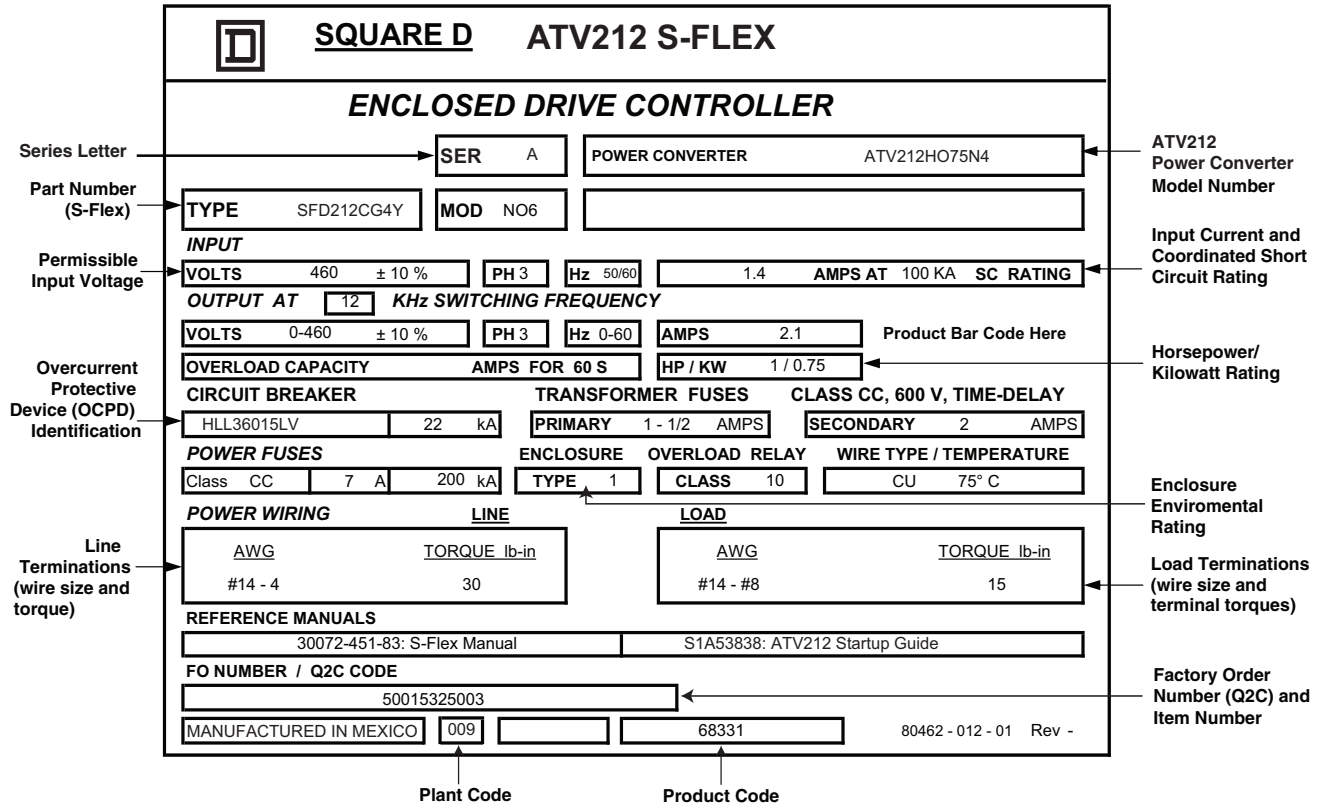
<sup>4</sup> Options A07, Drive Input Disconnect, and B07, Line Contactor, are available only when a full voltage bypass (Y05) option is selected. Options A07 and B07 are mutually exclusive.

<sup>5</sup> Optional for Type 1 only, standard on Type 12K and 3R.

## Nameplate Identification

The nameplate for the S-Flex enclosed drive is located on the inside of the door. See Figure 1. The nameplate identifies the drive type and modification options. When identifying or describing the S-Flex enclosed drive, use the data from the nameplate.

Figure 1 – S-Flex 212 Nameplate Example



## Technical Characteristics

Table 3 – Variable Torque Ratings

S-Flex Catalog Number <sup>1</sup>	Input Voltage 60 Hz (Vac)	Horsepower Rating (hp) <sup>2</sup>	Kilowatt Rating (kW)	Input Current (A) <sup>3</sup>	Output Current (A) <sup>2</sup>	Max. Transient Output Current (A) <sup>2</sup>	Total Dissipated Power at Rated Load <sup>4</sup>	Power Converter Part Number <sup>5</sup>
SFD212C•2*	208	1	0.75	3.3	4.6	5.1	184.2	ATV212HO75M3X
SFD212D•2*		2	1.5	6.1	7.5	8.3	228.3	ATV212HU15M3X
SFD212E•2*		3	2.2	8.7	10.6	11.7	256.0	ATV212HU22M3X
SFD212F•2*		5	4	15.7	16.7	19.3	326.8	ATV212HU40M3X
SFD212G•2*		7.5	5.5	20.8	24.2	26.6	384.7	ATV212HU55M3X
SFD212H•2*		10	7.5	27.9	30.8	35.2	495.0	ATV212HU75M3X
SFD212J•2*		15	11	42.1	46.2	50.8	641.2	ATV212HD11M3X
SFD212K•2*		20	15	56.1	59.4	67.1	846.1	ATV212HD15M3X
SFD212L•2*		25	18.5	67.3	74.8	82.3	939.1	ATV212HD18M3X
SFD212M•2*		30	22	80.4	88	96.8	1017.6	ATV212HD22M3X
SFD212N•2*		40	30	113.3	114	128.7	1414.3	ATV212HD30M3X

**Table 3 – Variable Torque Ratings** (continued)

S-Flex Catalog Number <sup>1</sup>	Input Voltage 60 Hz (Vac)	Horsepower Rating (hp) <sup>2</sup>	Kilowatt Rating (kW)	Input Current (A) <sup>3</sup>	Output Current (A) <sup>2</sup>	Max. Transient Output Current (A) <sup>2</sup>	Total Dissipated Power at Rated Load <sup>4</sup>	Power Converter Part Number <sup>5</sup>
SFD212C•3*	230	1	0.75	2.8	4.2	5.1	183.1	ATV212H075M3X
SFD212D•3*		2	1.5	5.3	6.8	8.3	226.1	ATV212HU15M3X
SFD212E•3*		3	2.2	7.6	9.6	11.7	252.1	ATV212HU22M3X
SFD212F•3*		5	4	13.5	15.2	19.3	323.5	ATV212HU40M3X
SFD212G•3*		7.5	5.5	18.1	22	26.6	381.0	ATV212HU55M3X
SFD212H•3*		10	7.5	24.4	28	35.2	489.1	ATV212HU75M3X
SFD212J•3*		15	11	35.7	42	50.8	630.6	ATV212HD11M3X
SFD212K•3*		20	15	47.6	54	67.1	829.5	ATV212HD15M3X
SFD212L•3*		25	18.5	58.0	68	82.3	918.3	ATV212HD18M3X
SFD212M•3*		30	22	69.0	80	96.8	994.1	ATV212HD22M3X
SFD212N•3*		40	30	93.0	104	128.7	1378.4	ATV212HD30M3X
SFD212C•4*		460	1	0.75	1.4	2.1	2.4	173.1
SFD212D•4*	2		1.5	2.5	3.4	4	197.6	ATV212HU15N4
SFD212E•4*	3		2.2	4.9	4.8	5.6	224.7	ATV212HU22N4
SFD212F•4*	5		4	6.4	7.6	10	303.6	ATV212HU40N4
SFD212G•4*	7.5		5.5	8.6	11	13.2	352.5	ATV212HU55N4
SFD212H•4*	10		7.5	11.7	14	17.6	418.8	ATV212HU75N4
SFD212J•4*	15		11	16.9	21	24.8	572.9	ATV212HD11N4
SFD212K•4*	20		15	22.6	27	33.6	765.8	ATV212HD15N4
SFD212L•4*	25		18.5	27.8	34	40.7	766.5	ATV212HD18N4
SFD212M•4*	30		22	33.1	40	47.9	806.0	ATV212HD22N4
SFD212N•4*	40		30	44.7	52	64.4	1041.5	ATV212HD30N4
SFD212P•4*	50		37	54.4	65	86.9	1241.6	ATV212HD37N4
SFD212Q•4*	60		45	65.9	77	103.4	1622.1	ATV212HD45N4
SFD212R•4*	75		55	89	96	127.6	2007.5	ATV212HD55N4
SFD212S•4*	100		75	111.3	124	176	2866.8	ATV212HD75N4

<sup>1</sup> The “•” indicates the enclosure type: “A” = Type 12K, “G” = Type 1, and “H” = Type 3R.

The “\*” indicates that the catalog number can end in a “Y” (for an S-Flex enclosed drive with full voltage bypass) or a “W” (for an S-Flex enclosed drive without bypass).

<sup>2</sup> These power, amperage, and wattage ratings apply to:

Power converters ATV212H075••• to HD15••• (1–20 hp) operating at a switching frequency of 12 kHz, and at 40 °C (104 °F) ambient temperature.

Power converters ATV212HD18••• to HD75••• (25–100 hp @ 460 V) operating at a switching frequency of 8 kHz, and at 40 °C (104 °F) ambient temperature. For a switching frequency between 13 kHz and 16 kHz, select the next largest size drive. If the duty cycle does not exceed 60% (36 s for a 60 s cycle) this is not necessary.

<sup>3</sup> Select the conductor based on the input line current or the motor FLA, whichever is greater.

<sup>4</sup> For btu/hr, multiply values by 3.413.

<sup>5</sup> Drives shown in the table are installed in SFD212 enclosed drives.

**▲ WARNING****HEAT OR FIRE DAMAGE**

- Protective devices must be properly coordinated.
- Do not connect the enclosed drive to a power feeder whose short circuit capacity exceeds the short circuit rating listed on the enclosed drive nameplate.

**Failure to follow these instructions can result in death or serious injury.**

## Short Circuit Ratings

All configurations have a short-circuit withstand rating of 100,000 A (symmetrical).

## Input Current Ratings

All branch circuit components and equipment must be rated for the input current of the drive or the motor full load current (FLA), whichever is greater. Branch circuit components and equipment include: transformers, feeder cables, disconnect devices, and protective devices. The input current rating is printed on the nameplate. See Figure 1 on page 12. The branch circuit feeder protection must be sized according to NEC Article 430.

## Technical Specifications

**Table 4 – S-Flex 212 Product Specifications**

Electrical Specifications	
Input voltage	208 Vac ± 10%, 230 Vac ± 10%, 460 Vac ± 10%
Displacement power factor	Approximately 0.96
Input frequency	50/60 Hz ± 5%
Output voltage	Three-phase output, maximum voltage equal to input voltage
Galvanic isolation	Galvanic isolation between power and control (inputs, outputs, and power supplies)
Frequency range of the power converter	0.5 to 200 Hz (factory setting of 60 Hz maximum)
Current limit	110% of nominal drive full load current (FLA) for 60 s
Switching frequency	Selectable from 6 to 16 kHz, factory setting: 12 kHz <sup>1</sup> 1–20 hp; 8 kHz <sup>2</sup> above 25 hp
Speed reference	VIA: 4 to 20 mA, Impedance = 242 Ω or 0 to 10 Vdc, Impedance = 30 kΩ 0 to 20 mA, Impedance = 242 W (reassignable, X-Y range with keypad display) VIB: 0 to +10 V, Impedance = 30 kΩ
Frequency resolution in analog reference	0.0048 Hz (11 bits)
Speed accuracy 20–100% of motor rated torque	+/- 10% of nominal slip without speed feedback
Efficiency	Typically greater than 95%
Reference sample time	2 ms
Acceleration and deceleration ramps	0.1 to 3200 seconds (adjustable in 0.1 s increments)
Motor protection	Class 10 overload protection with bypass in addition to internal electronic thermal protection.
Keypad display	Self-diagnostics with status messages. 7-segment LED display (standard) Full text keypad, 8 languages (optional) Also see <i>Altivar 212 Installation Guide</i> , S1A53832

**Table 4 – S-Flex 212 Product Specifications** (continued)

<b>Environmental Specifications</b>	
Storage temperature	-13 to +158 °F (-25 to +70 °C)
Operating temperature	+14 to +104 °F (-10 to +40 °C), Types 1, 12, and 3R; For 50 °C operating temperature, derate by one frame size. For 50 °C 3R applications, it is recommended to go up one frame size.
Humidity	95% with no condensation or dripping water, conforming to IEC 60068-2-3.
Altitude	3,300 ft. (1000 m) maximum without derating; derate the current by 1% for each additional 330 ft. (100 m) up to 10,000 ft. (3000 m).
Enclosure <sup>3</sup>	UL Type 1: General indoor (ventilated); UL Type 12K: Indoor dust-tight (ventilated); UL Type 3R: Outdoor (ventilated)
Pollution degree	Pollution degree 2 per NEMA ICS-1 and IEC 60664-1
Resistance to vibrations (Power converter only)	According to IEC 60068-2-6: 1.5 mm peak to peak from 3 to 13 Hz 1 g from 13 to 150 Hz
Resistance to shocks (Power converter only)	According to IEC 60068-2: 15 g, 11 ms
Transit test to shock	Conforms to International Safe Transit Association guidelines.
Codes and standards	<b>Type 1:</b> UL Listed per UL508C, cUL Listed per CSA C22.2 No 274-13, as incorporating Class 10 electronic and electromechanical overload protection. <b>Type 12K and 3R:</b> UL Listed per UL 508A, cUL Listed per CSA C22.2 No. 14-13. Conforms to applicable NEMA ICS, NFPA, and IEC standards. Manufactured under ISO 9001 standards. Seismic Certification: <ul style="list-style-type: none"> <li>• IBC, NFPA 5000 and ASCE7</li> <li>• ICC ES AC 156 <sup>4</sup></li> </ul>

<sup>1</sup> Above 12 kHz derate the drive per the graphs in the *Altivar 212 Installation Guide*, S1A53832.

<sup>2</sup> Above 8 kHz derate the drive per the graphs in the *Altivar 212 Installation Guide*, S1A53832.

<sup>3</sup> Plenum rated; suitable for placement in a compartment handling conditioned air. Type 1 only.

<sup>4</sup> Acceptance criteria test protocol with an importance factor of 1.5.

## Section 2— Receiving, Handling, and Storing

### **▲ WARNING**

#### **DAMAGED EQUIPMENT**

Do not operate or install any S-Flex enclosed drive that appears damaged.

**Failure to follow these instructions can result in death, serious injury, or equipment damage.**

### Receiving and Preliminary Inspection

Before shipment from the factory, each S-Flex enclosed drive is inspected visually, electrically, and mechanically by professional quality-control analysts. Certification of quality control testing is available upon request.

The S-Flex enclosed drive must be thoroughly inspected before it is stored or installed. Upon receipt:

1. Remove the S-Flex enclosed drive from its packaging and visually inspect the exterior for shipping damage.
2. Ensure that the catalog number of the S-Flex enclosed drive, which appears on the nameplate, agrees with the packing slip and corresponding purchase order. See Figure 1 on page 12.
3. If you find any shipping damage, notify the carrier and your Schneider Electric sales representative.

### Storing the Equipment

### **NOTICE**

#### **STACKING DURING STORAGE OR SHIPPING**

- Do not stack S-Flex enclosed drives on top of each other.
- Do not place any material on top of the S-Flex enclosed drive.
- Store or ship the S-Flex enclosed drive in the original packaging.

**Failure to follow these instructions can result in equipment damage.**

If you plan to store the S-Flex enclosed drive after receipt, replace it in its original packaging and store it in a clean, dry area where the ambient temperature is between -13 to +158 °F (-25 to +70 °C). If the enclosed drive must be shipped to another location, use the original shipping material and carton to help protect it.

**NOTE:** Storing the equipment in its original packaging until it reaches its final installation site helps protect the equipment and helps prevent damage to its exterior.



## Unpacking the Enclosed Drive

### WARNING

#### HEAVY EQUIPMENT

- Lifting the S-Flex enclosed drive requires the use of a lifting apparatus and a minimum of two people.
- Always use safe lifting practices.

**Failure to follow these instructions can result in death, serious injury, or equipment damage.**

Handle the S-Flex enclosed drive carefully to avoid damage to the internal components, frame, and exterior. Lift the S-Flex enclosed drive out of its shipping carton, lifting with a minimum of two people or a suitable lifting apparatus, and place it on a flat surface.

## Before Installing the Enclosed Drive

Before installing the S-Flex enclosed drive, visually verify that all components are properly seated, securely fastened, and undamaged.

1. Unlatch and open the door of the enclosed drive.
2. Visually verify that:
  - All internally mounted hardware and terminal connection hardware is properly seated, securely fastened, and undamaged.
  - The control transformer fuses are in place in the fuse block.
3. Close and latch the S-Flex enclosed drive door.

## Handling the Enclosed Drive

### WARNING

#### HANDLING AND LIFTING HAZARD

- Keep the area below any equipment being lifted clear of all personnel and property.
- Lifting the S-Flex enclosed drive requires the use of a lifting apparatus and two people. Use the lifting method shown in Figure 2 on page 18.
- Before lifting the enclosed drive:
  - Inspect the lifting plates, holes, slots, and eyebolts for any damage.
  - Attach a spreader bar.
  - Keep the lifting force vertical.
  - Limit the swing angle to less than 45°.

**Failure to follow these instructions can result in death, serious injury, or equipment damage.**

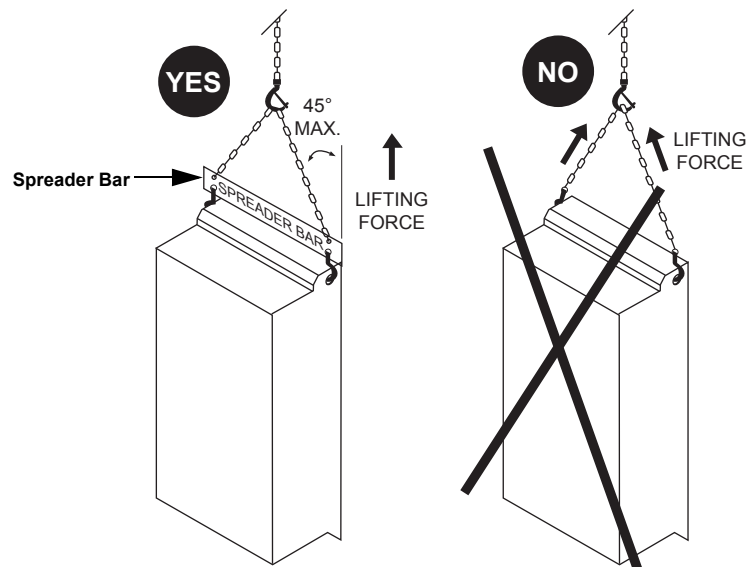
When handling enclosed drives:

- Always work with another person. The weight, size, and shape of the enclosed drive is such that two people are required to handle it.
- Use cut-resistant gloves.
- Attach a spreader bar to the two top lifting holes on the enclosed drive back panel and hoist it with chains or straps. See Figure 2 for the proper hoisting method and Figure 3 for the lifting points on the S-Flex enclosed drive.
- Raise the enclosed drive from a horizontal position (that is, the back of the device resting on a pallet).
- Place the enclosed drive in an upright position.

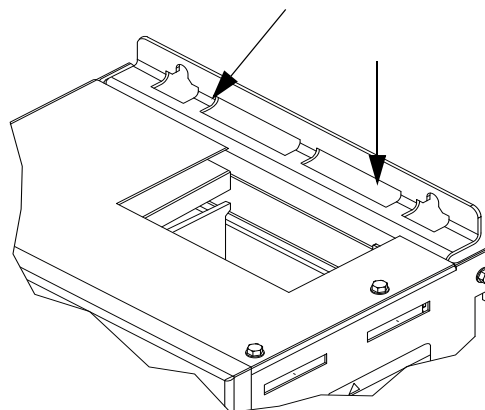
**NOTE:** Wall mounted enclosures will not sit upright without support. The bottom of the wall mounted enclosure is on an angle.

- Mount the enclosed drive on a flat, solid, noncombustible vertical surface, capable of supporting its weight.
- Secure all four corners of the enclosed drive with hardware of a sufficient size and type capable of supporting its weight.

**Figure 2 – Hoisting the S-Flex Drives**



**Figure 3 – Lifting Points on the S-Flex Enclosed Drives**



# Section 3— Installation and Start-up

## Installation Guidelines

**⚠ DANGER**

**HAZARD OF ELECTRIC SHOCK, EXPLOSION, OR ARC FLASH**

Read and understand the precautions in “Before You Begin” starting on page 8 before performing the procedures in this section.

**Failure to follow these instructions will result in death or serious injury.**

Follow these precautions when installing the S-Flex enclosed drive:

- The enclosed drive is suitable for installation in a pollution degree 2 environment, as defined in NEMA ICS1 and IEC 60664-1.
- When attaching wall-mountable enclosed drives to their mounting surfaces, use fasteners rated for the weight of the device, the expected shock and vibration of the installation, and the expected environment. See Tables 5–7 on pages 19–20 for S-Flex enclosed drive weights.
- Provide sufficient cooling for the expected heat load. See Table 3 on page 12 for dissipated power at rated load.
- Do not mount the enclosed drive in direct sunlight or on hot surfaces. Mount it on a solid, flat surface only.

## Weights

**Table 5 – 460 V S-Flex 212 Weights**

Catalog Number <sup>1</sup>	hp	Type 1 (G03)		Type 12K/3R (A03/H03)	
		Weight lb (kg) <sup>2</sup>	Weight w/Mod X07 lb (kg)	Weight lb (kg) <sup>2</sup>	Weight w/Mod X07 lb (kg)
SFD212C•4*	1	52 (23.5)	83 (37.7)	135 (61)	140 (63.5)
SFD212D•4*	2	52 (23.5)	83 (37.7)	135 (61)	140 (63.5)
SFD212E•4*	3	52 (23.5)	83 (37.7)	135 (61)	140 (63.5)
SFD212F•4*	5	52 (23.5)	83 (37.7)	135 (61)	140 (63.5)
SFD212G•4*	7.5	52 (23.5)	83 (37.7)	135 (61)	140 (63.5)
SFD212H•4*	10	52 (23.5)	83 (37.7)	175 (79.4)	180 (81.6)
SFD212J•4*	15	52 (23.5)	83 (37.7)	175 (79.4)	180 (81.6)
SFD212K•4*	20	111 (50.3)	133 (60.33)	270 (122.5)	290 (131.5)
SFD212L•4*	25	111 (50.3)	133 (60.33)	270 (122.5)	290 (131.5)
SFD212M•4*	30	140 (63.5)	223 (101.2)	270 (122.5)	290 (131.5)
SFD212N•4*	40	140 (63.5)	223 (101.2)	270 (122.5)	290 (131.5)
SFD212P•4*	50	140 (63.5)	223 (101.2)	330 (149.7)	360 (163.3)
SFD212Q•4*	60	140 (63.5)	223 (101.2)	330 (149.7)	360 (163.3)
SFD212R•4*	75	206 (93.4)	278 (126)	330 (149.7)	360 (163.3)
SFD212S•4*	100	206 (93.4)	278 (126)	330 (149.7)	360 (163.3)

<sup>1</sup> The “•” indicates the enclosure type: “A” = Type 12K, “G” = Type 1, and “H” = Type 3R.  
 The “\*” indicates that the catalog number can end in a “Y” (for an S-Flex enclosed drive with full voltage bypass) or a “W” (for an S-Flex enclosed drive without bypass).

<sup>2</sup> The weight varies depending on modification options.

**Table 6 – 230 V S-Flex 212 Weights**

Catalog Number <sup>1</sup>	hp	Type 1 (G03)		Type 12K/3R (A03/H03)	
		Weight lb (kg) <sup>2</sup>	Weight w/Mod X07 lb (kg)	Weight lb (kg) <sup>2</sup>	Weight w/Mod X07 lb (kg)
SFD212C•3*	1	52 (23.5)	83 (37.7)	135 (61)	140 (63.5)
SFD212D•3*	2	52 (23.5)	83 (37.7)	135 (61)	140 (63.5)
SFD212E•3*	3	52 (23.5)	83 (37.7)	135 (61)	140 (63.5)
SFD212F•3*	5	52 (23.5)	83 (37.7)	135 (61)	140 (63.5)
SFD212G•3*	7.5	52 (23.5)	83 (37.7)	175 (79.4)	185 (83.9)
SFD212H•3*	10	52 (23.5)	83 (37.7)	175 (79.4)	185 (83.9)
SFD212J•3*	15	111 (50.3)	133 (60.33)	270 (122.5)	300 (136.1)
SFD212K•3*	20	111 (50.3)	133 (60.33)	270 (122.5)	300 (136.1)
SFD212L•3*	25	111 (50.3)	133 (60.33)	270 (122.5)	300 (136.1)
SFD212M•3*	30	140 (63.5)	223 (101.2)	270 (122.5)	300 (136.1)
SFD212N•3*	40	206 (93.4)	278 (126)	330 (149.7)	360 (163.3)

<sup>1</sup> The “•” indicates the enclosure type: “A” = Type 12K, “G” = Type 1, and “H” = Type 3R.

The “\*” indicates that the catalog number can end in a “Y” (for an S-Flex enclosed drive with full voltage bypass) or a “W” (for an S-Flex enclosed drive without bypass).

<sup>2</sup> The weight varies depending on modification options.

**Table 7 – 208 V S-Flex 212 Weights**

Catalog Number <sup>1</sup>	hp	Type 1 (G03)		Type 12K/3R (A03/H03)	
		Weight lb (kg) <sup>2</sup>	Weight w/Mod X07 lb (kg)	Weight lb (kg) <sup>2</sup>	Weight w/Mod X07 lb (kg)
SFD212C•2*	1	52 (23.5)	83 (37.7)	135 (61)	140 (63.5)
SFD212D•2*	2	52 (23.5)	83 (37.7)	135 (61)	140 (63.5)
SFD212E•2*	3	52 (23.5)	83 (37.7)	135 (61)	140 (63.5)
SFD212F•2*	5	52 (23.5)	83 (37.7)	135 (61)	140 (63.5)
SFD212G•2*	7.5	52 (23.5)	83 (37.7)	175 (79.4)	185 (83.9)
SFD212H•2*	10	52 (23.5)	83 (37.7)	175 (79.4)	185 (83.9)
SFD212J•2*	15	111 (50.3)	133 (60.33)	270 (122.5)	300 (136.1)
SFD212K•2*	20	111 (50.3)	133 (60.33)	270 (122.5)	300 (136.1)
SFD212L•2*	25	111 (50.3)	133 (60.33)	270 (122.5)	300 (136.1)
SFD212M•2*	30	140 (63.5)	223 (101.2)	270 (122.5)	300 (136.1)
SFD212N•2*	40	206 (93.4)	278 (126)	330 (149.7)	360 (163.3)

<sup>1</sup> The “•” indicates the enclosure type: “A” = Type 12K, “G” = Type 1, and “H” = Type 3R.

The “\*” indicates that the catalog number can end in a “Y” (for an S-Flex enclosed drive with full voltage bypass) or a “W” (for an S-Flex enclosed drive without bypass).

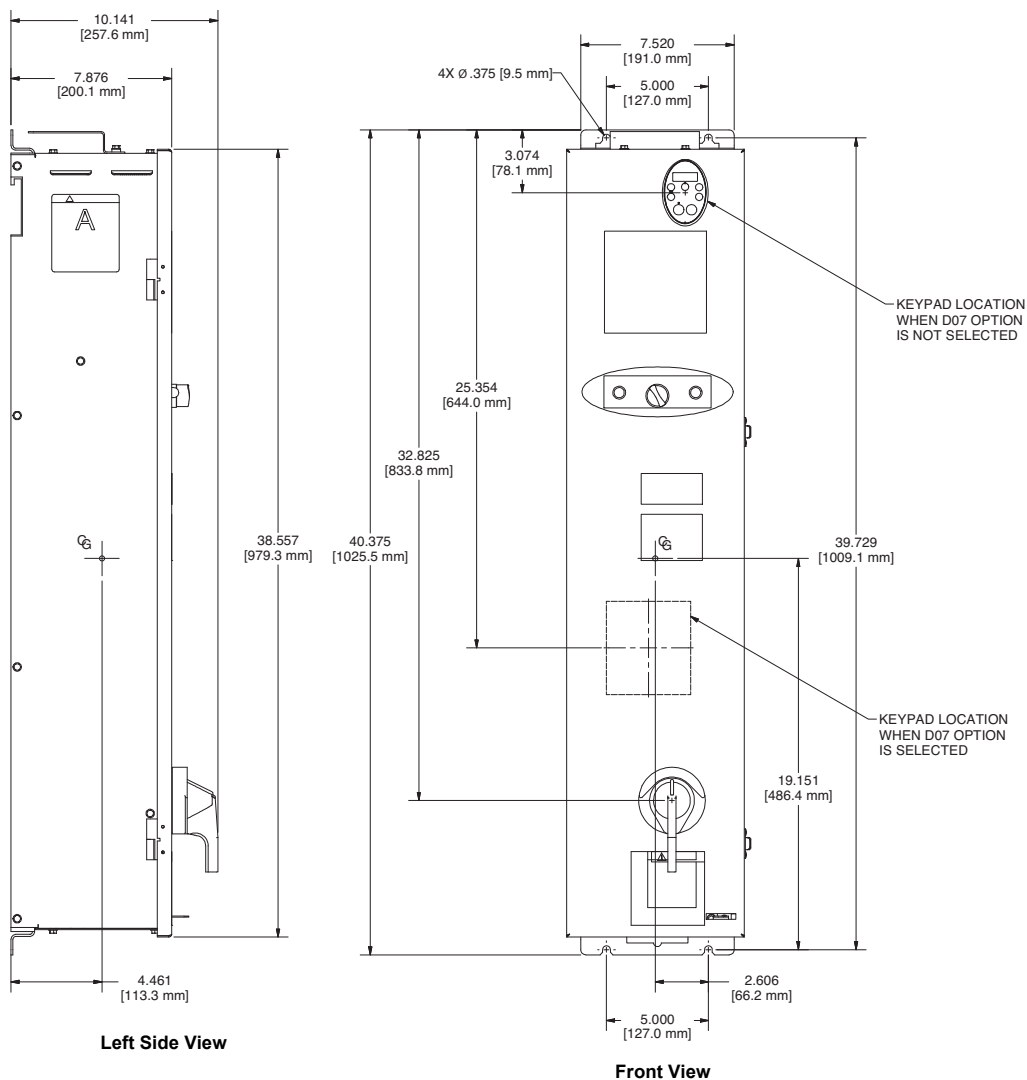
<sup>2</sup> The weight varies depending on modification options.

## Center of Gravity

Center of gravity information is provided for reference in mounting and for consideration in structural analysis.

# Dimensions for Wall or Panel Mounting

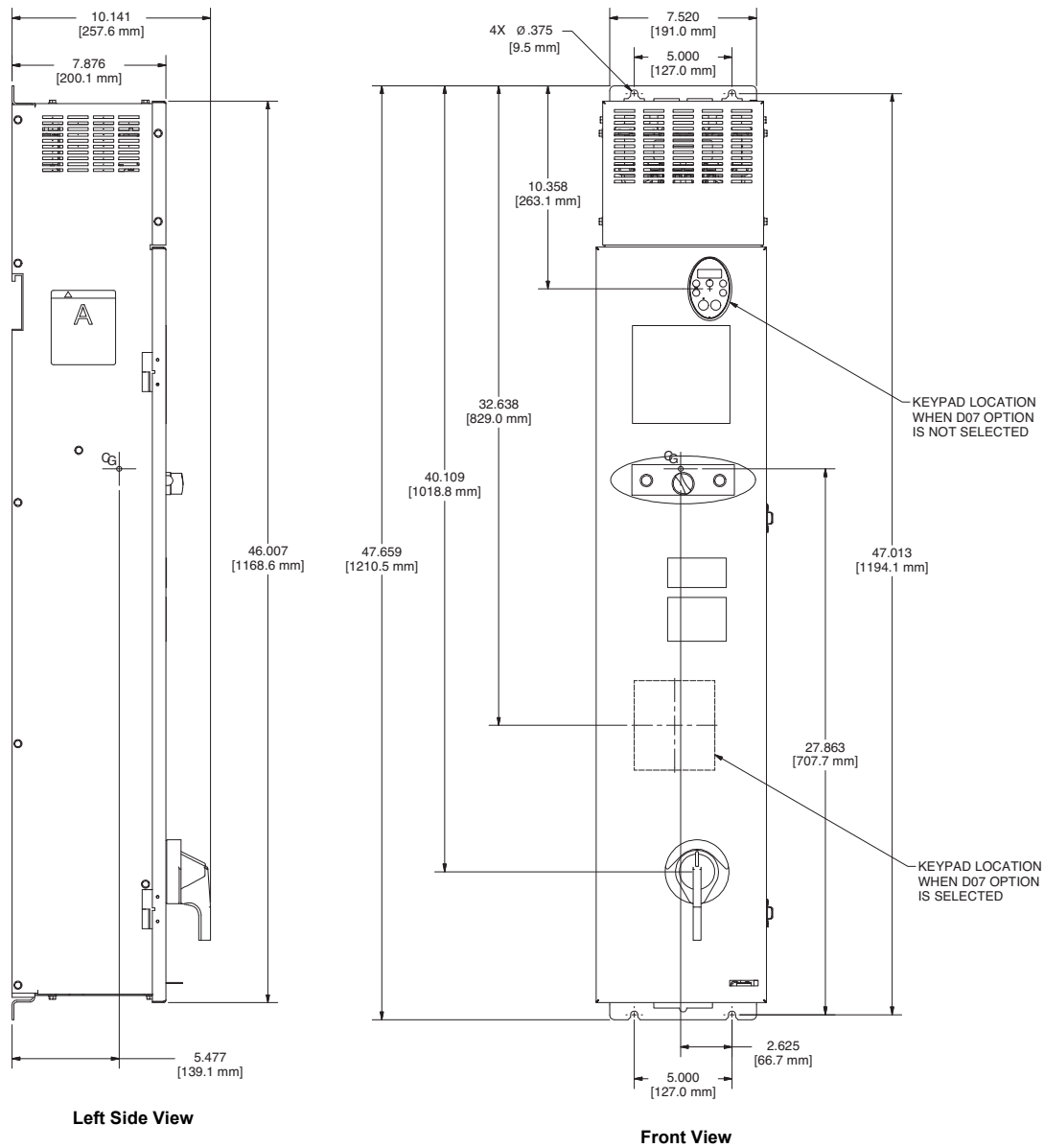
Figure 4 – Frame Size A, Type 1: 1–10 hp @ 208/230 Vac and 1–15 hp @ 460 Vac



Dimensions: Inches [mm]

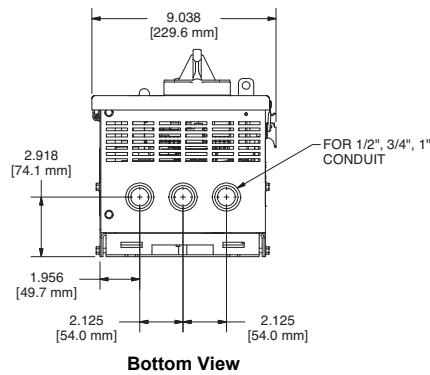
**NOTE:** Standard Bypass control package is shown.

**Figure 5 – Frame Size A, Type 1: 1–10 hp @ 208/230 Vac and 1–15 hp @ 460 Vac with Line Reactor**

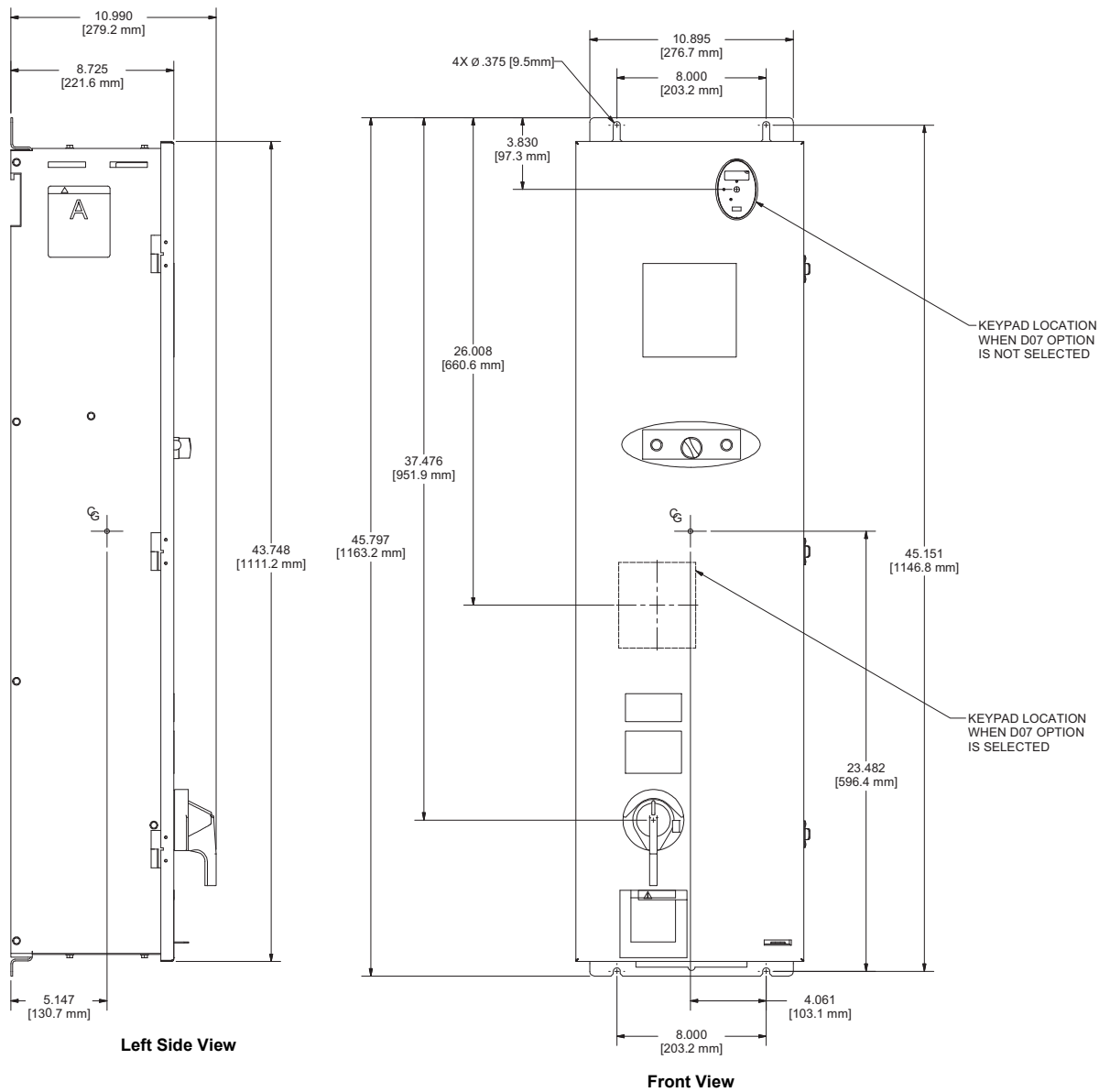


Dimensions: Inches [mm]

**NOTE:** Standard Bypass control package is shown.



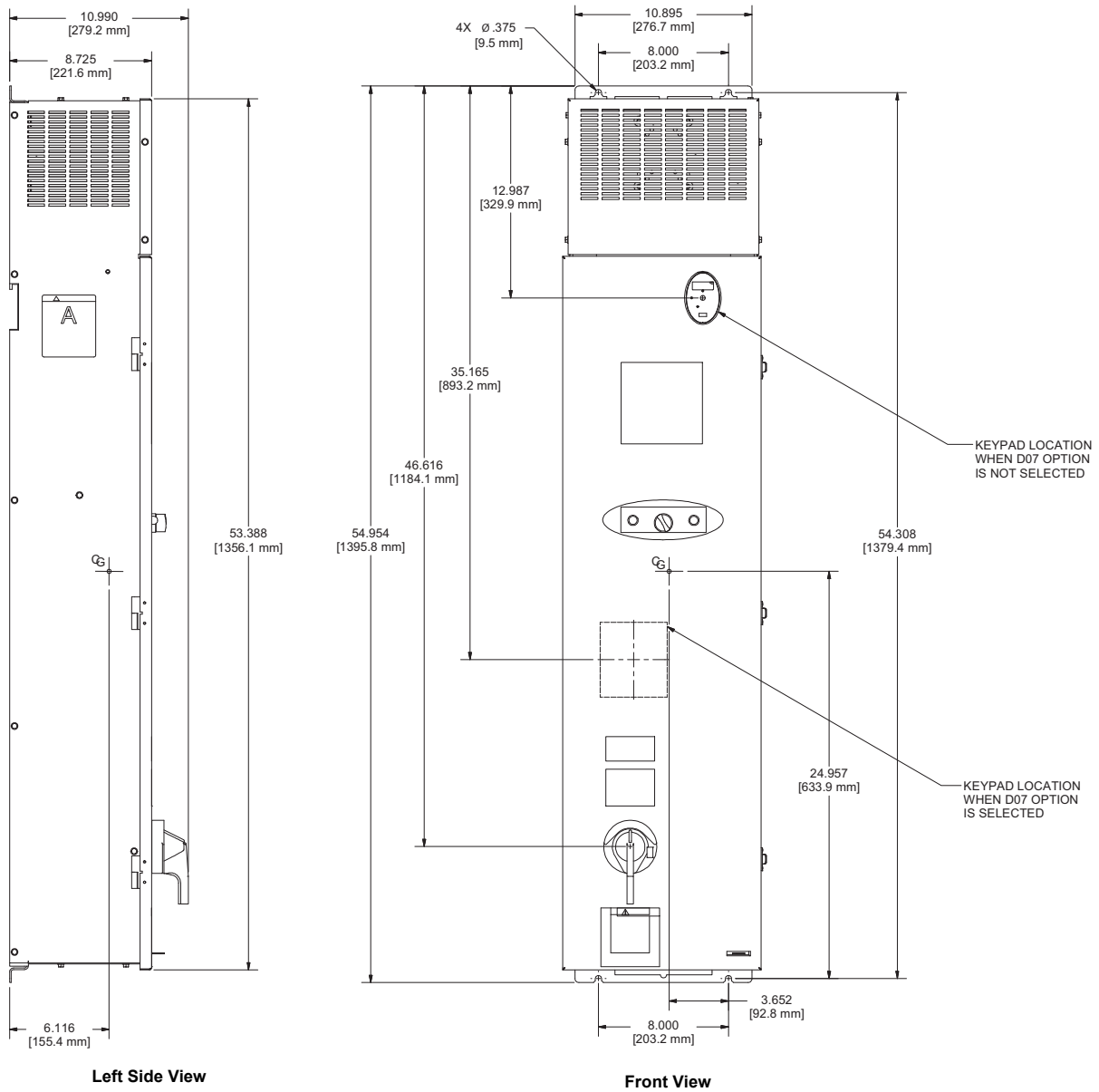
**Figure 6 – Frame Size B, Type 1: 15–25 hp @ 208/230 Vac and 20–25 hp @ 460 Vac**



Dimensions: Inches [mm]

**NOTE:** Standard Bypass control package as shown.

**Figure 7 – Frame Size B, Type 1: 15–25 hp @ 208/230 Vac and 20–25 hp @ 460 Vac with Line Reactor**

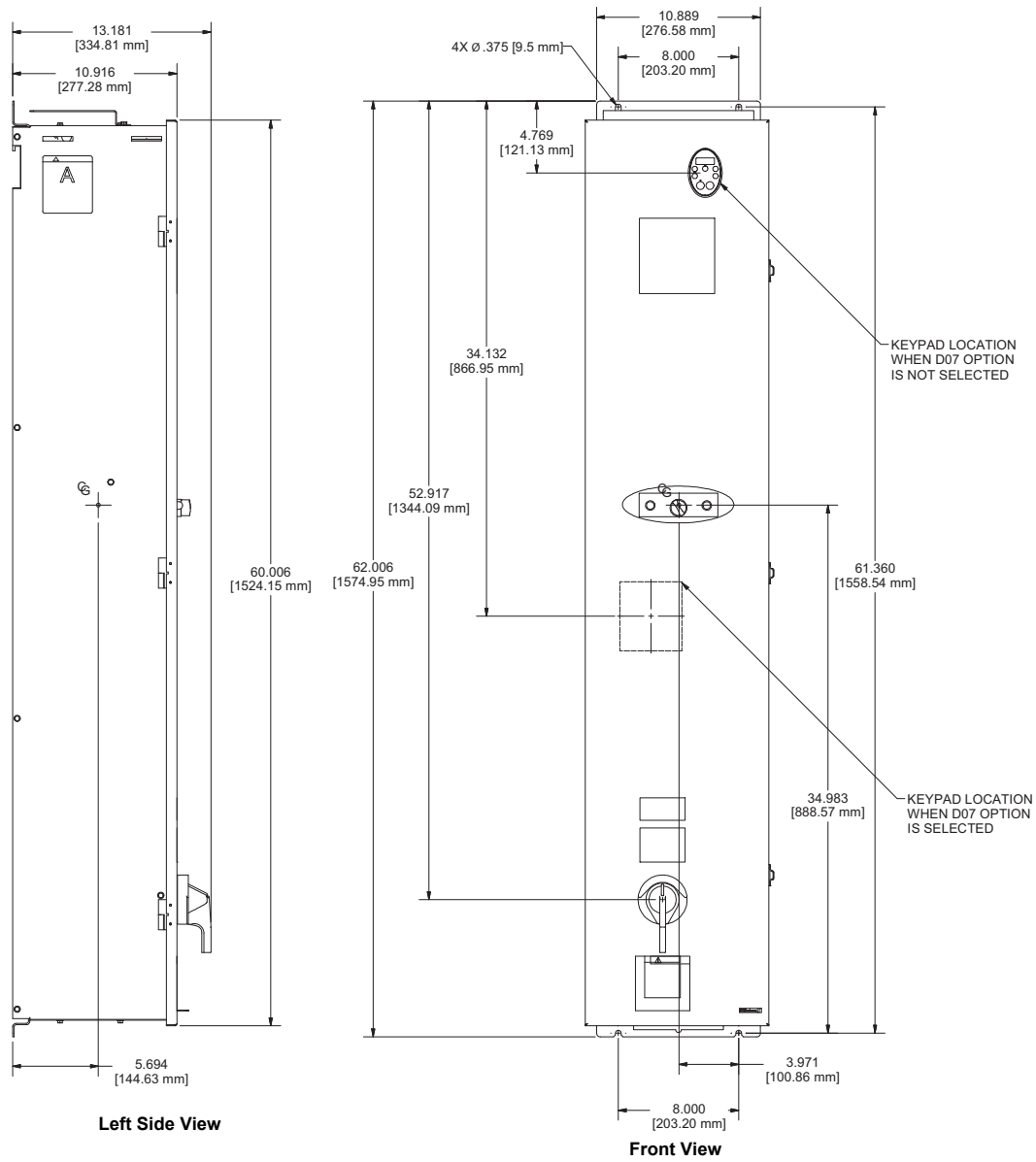


Dimensions: Inches [mm]

**NOTE:** Standard Bypass control package as shown.



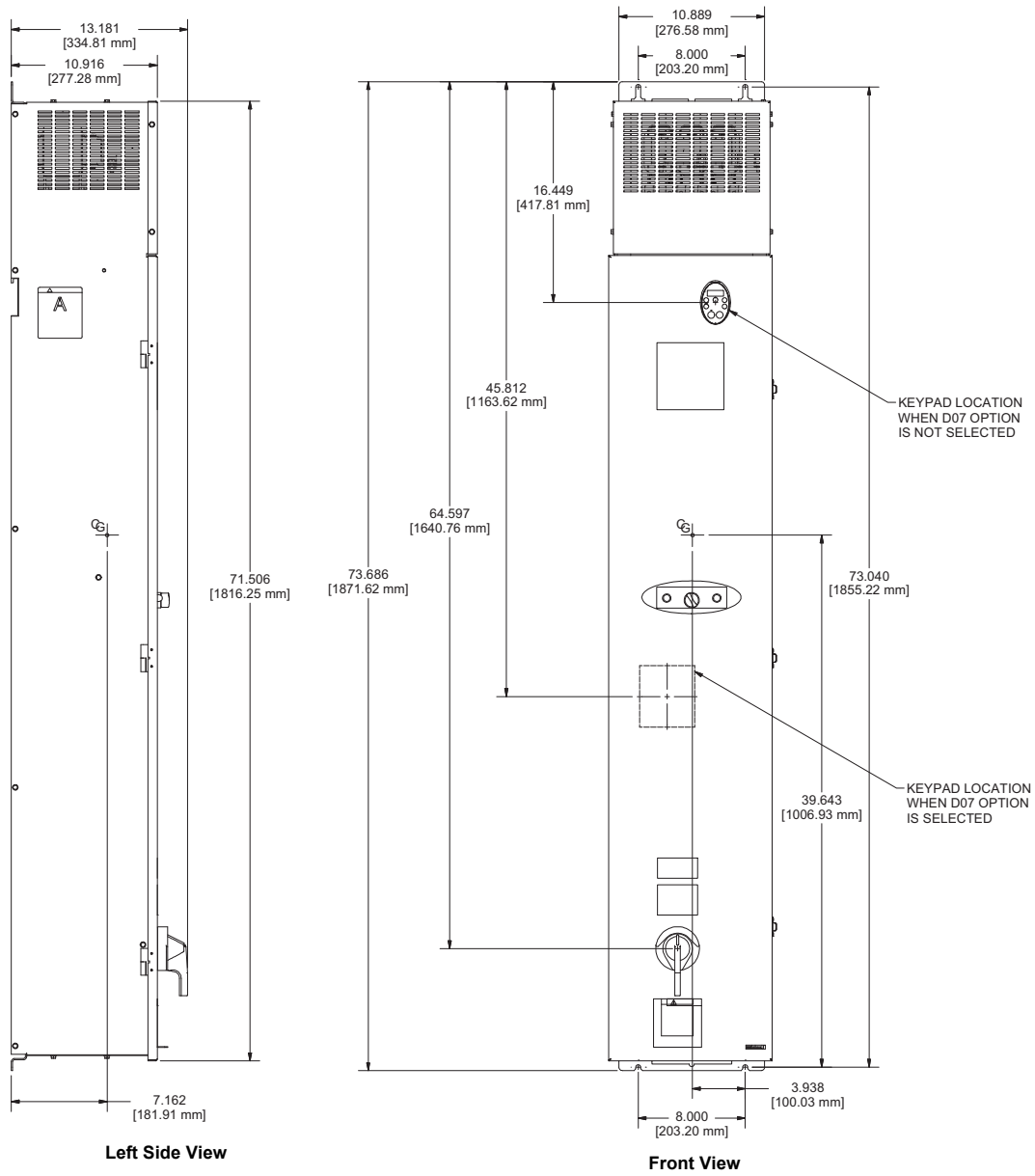
**Figure 8 – Frame Size C, Type 1: 30 hp @ 208/230 Vac and 30–60 hp @ 460 Vac**



Dimensions: Inches [mm]

**NOTE:** Standard Bypass control package as shown.

**Figure 9 – Frame Size C, Type 1: 30 hp @ 208/230 Vac and 30–60 hp @ 460 Vac with Line Reactor**



Dimensions: Inches  
[mm]

**NOTE:** Standard Bypass control package as shown.

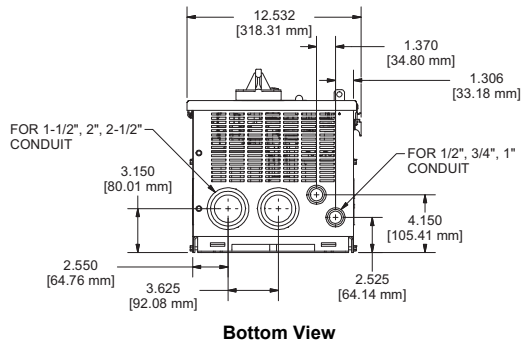
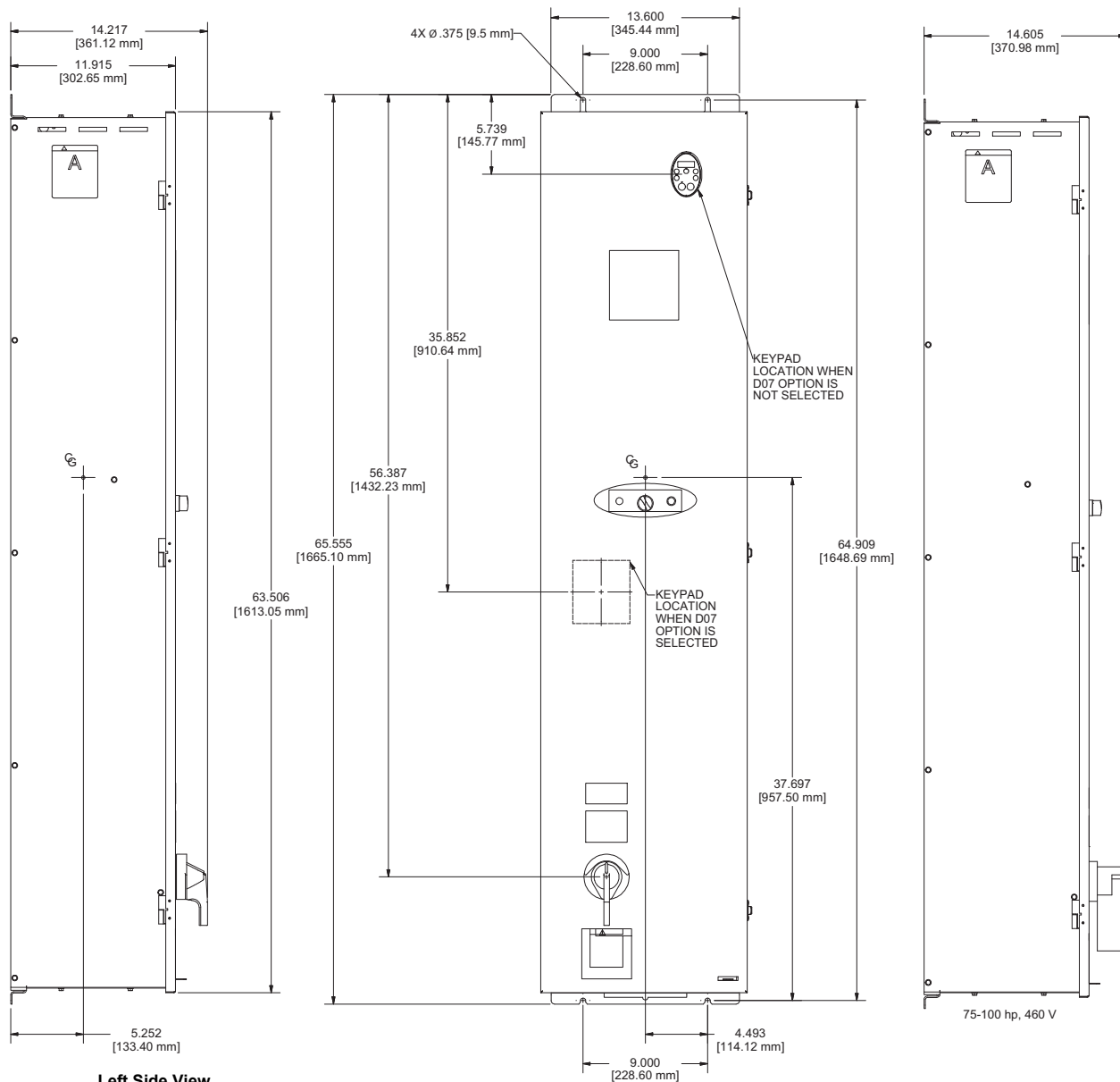
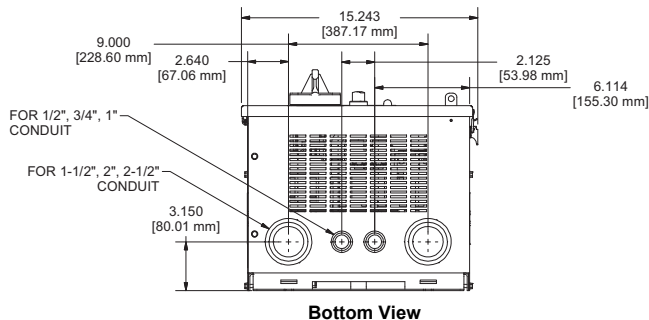


Figure 10 – Frame Size D, Type 1: 40 hp @ 208/230 Vac and 75–100 hp @ 460 Vac

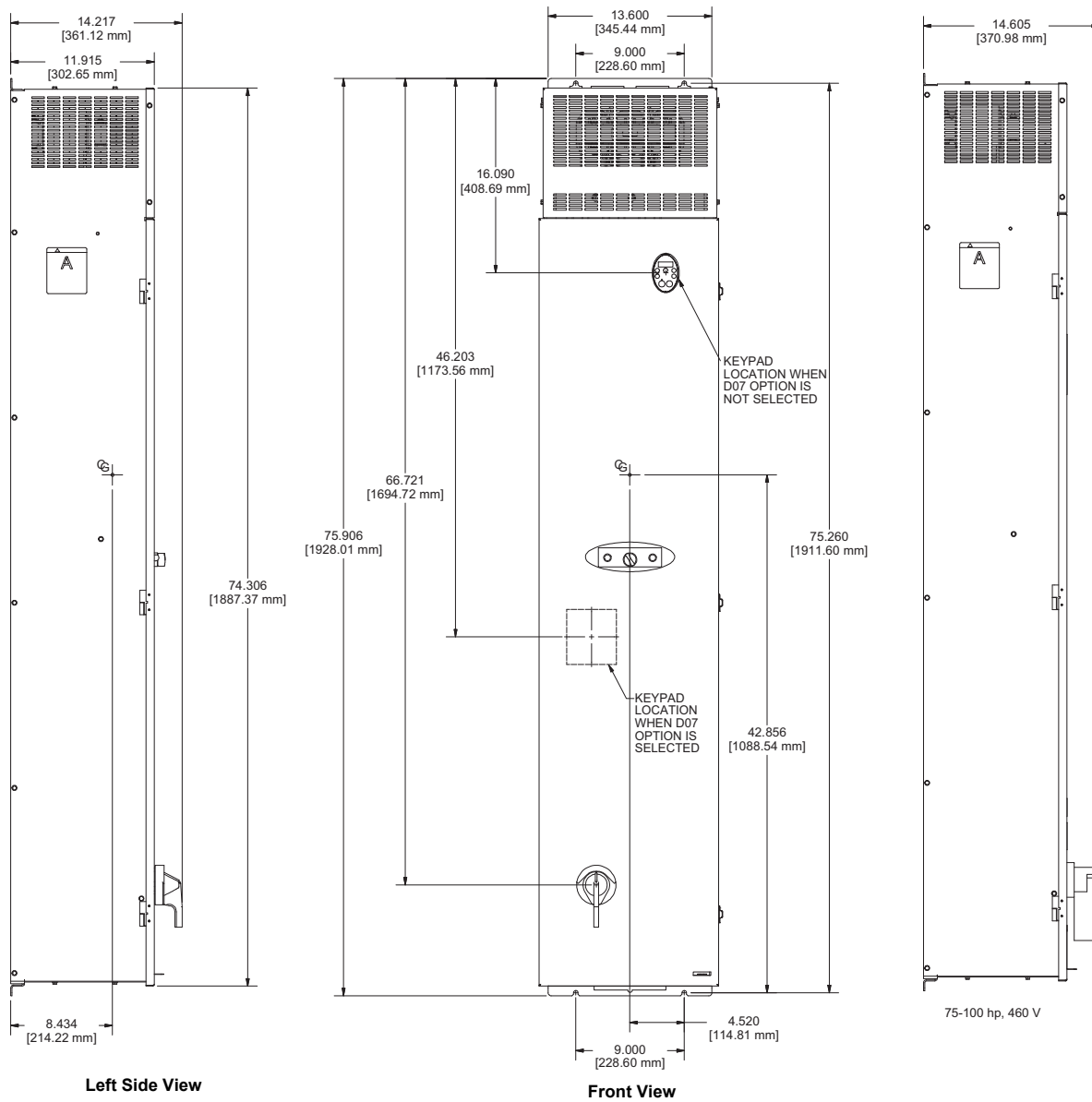


Dimensions: Inches  
[mm]

**NOTE:** Standard Bypass control package as shown.



**Figure 11 – Frame Size D, Type 1: 40 hp @ 208/230 Vac and 75–100 hp @ 460 Vac with Line Reactor**



**Dimensions:** Inches [mm]

**NOTE:** Standard Bypass control package as shown.

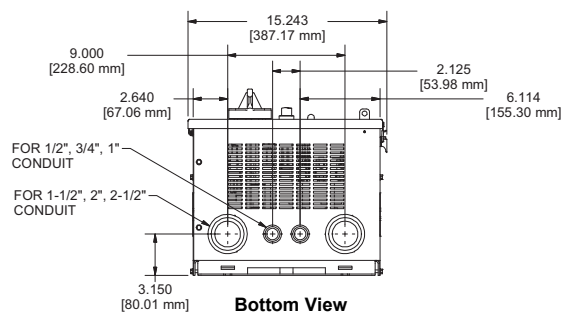


Figure 12 – Frame Size A, Type 12K: 1–5 hp @ 208/230 Vac and 1–7.5 hp @ 460 Vac

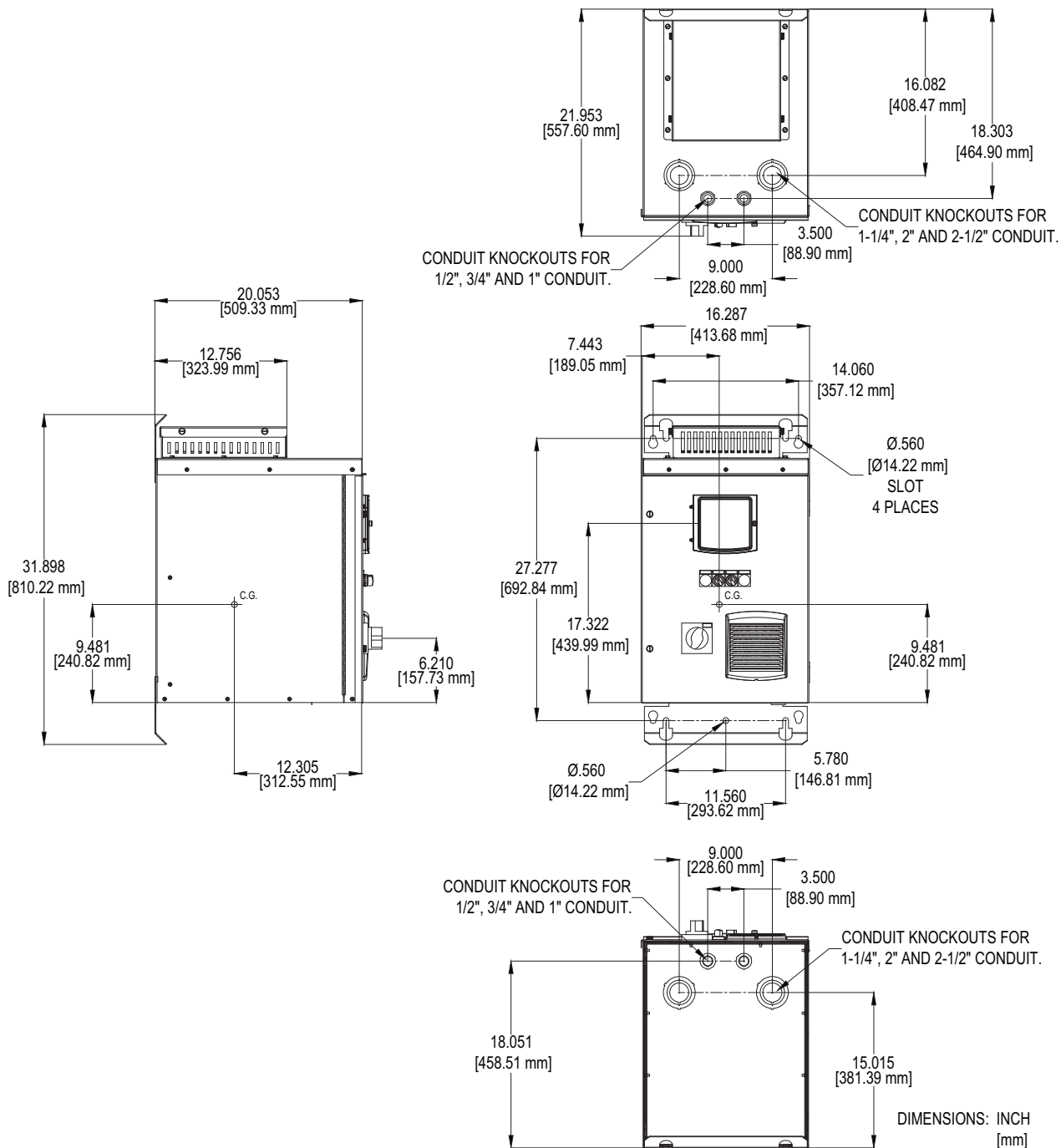


Figure 13 – Frame Size A, Type 12K Seismic: 1–5 hp @ 208/230 Vac and 1–7.5 hp @ 460 Vac

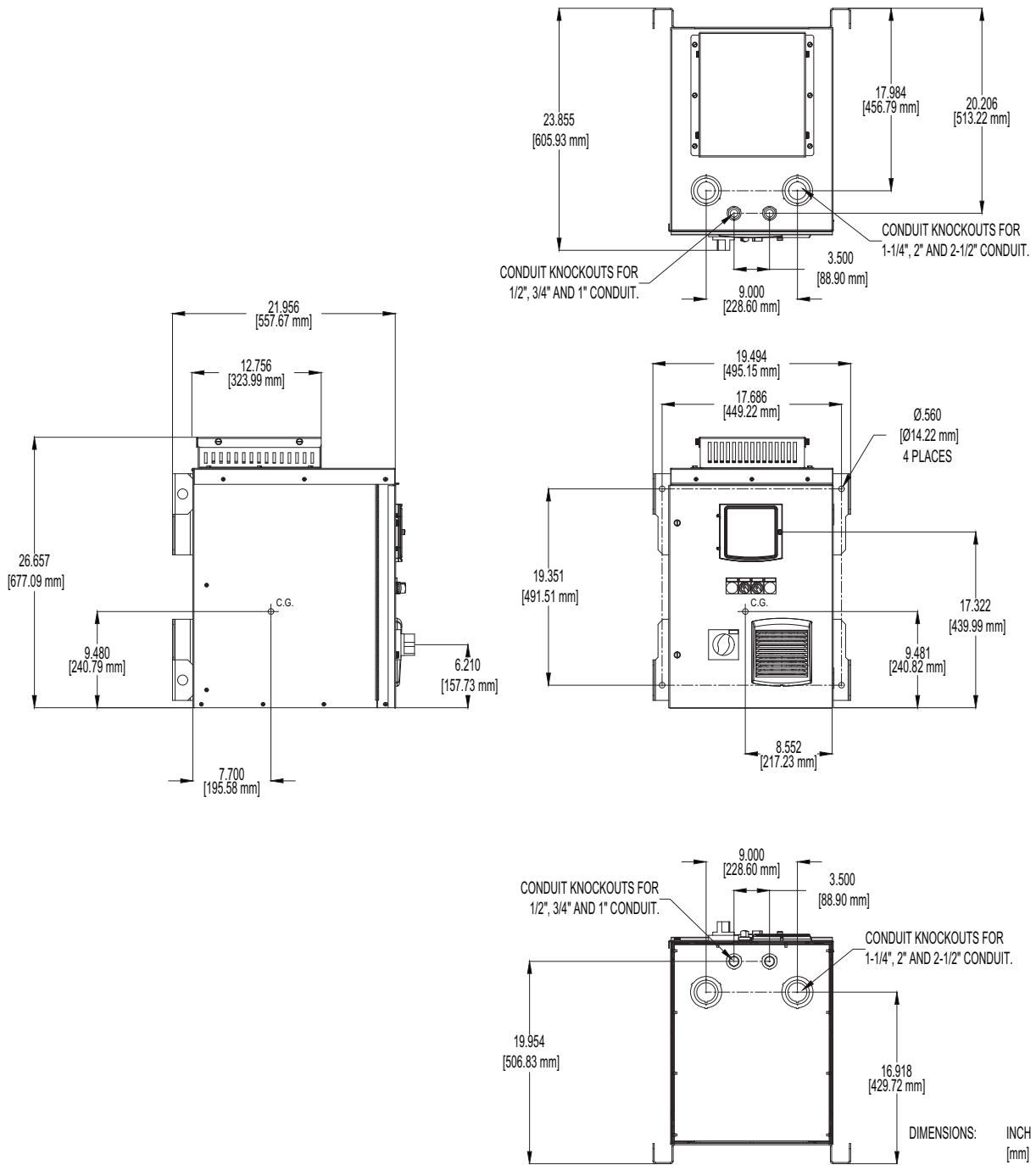
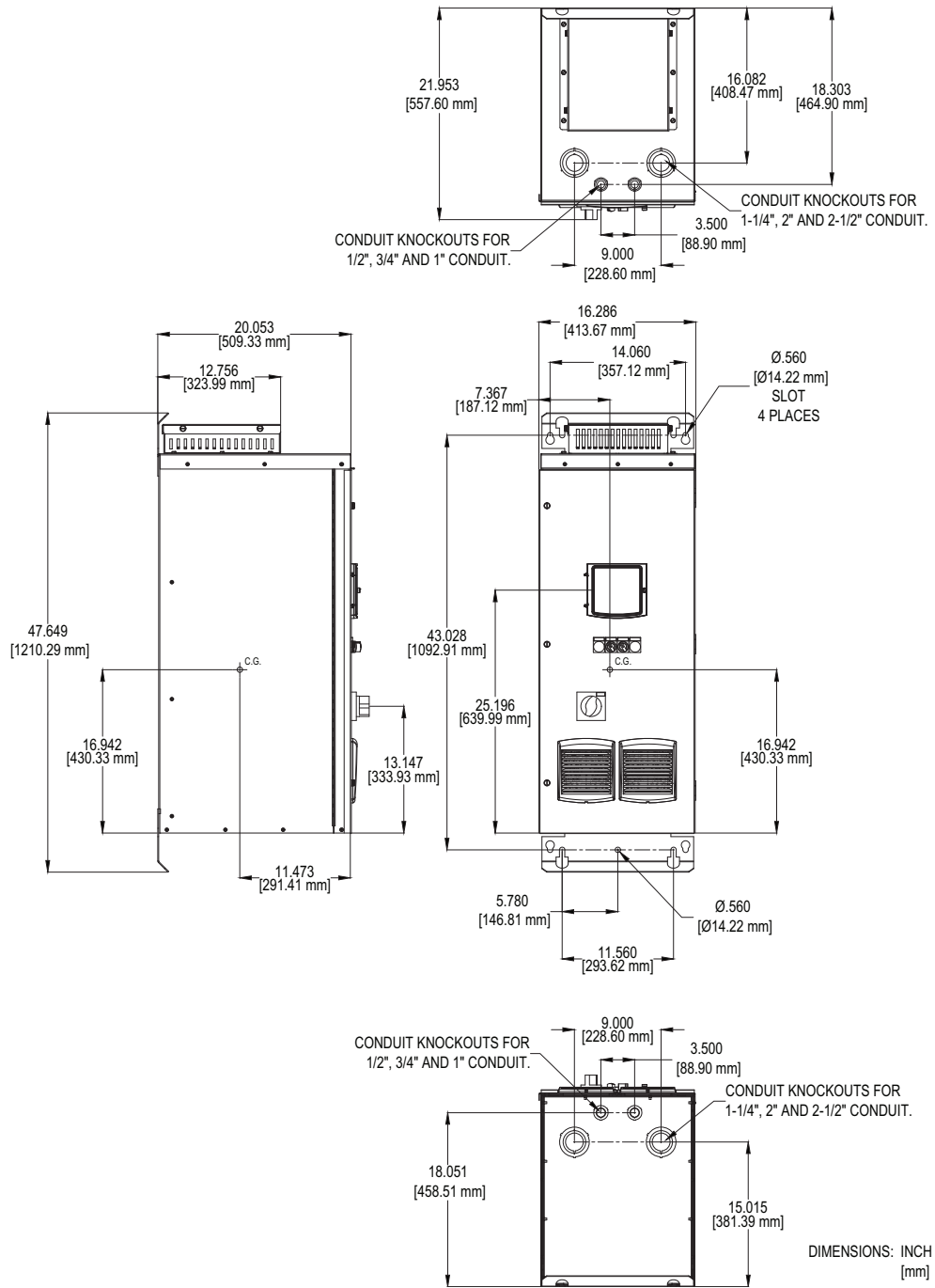


Figure 14 – Frame Size B, Type 12K: 7.5–10 hp @ 208/230 Vac and 10–15 hp @ 460 Vac



**Figure 15 – Frame Size B, Type 12K Seismic: 7.5–10 hp @ 208/230 Vac and 10–15 hp @ 460 Vac**

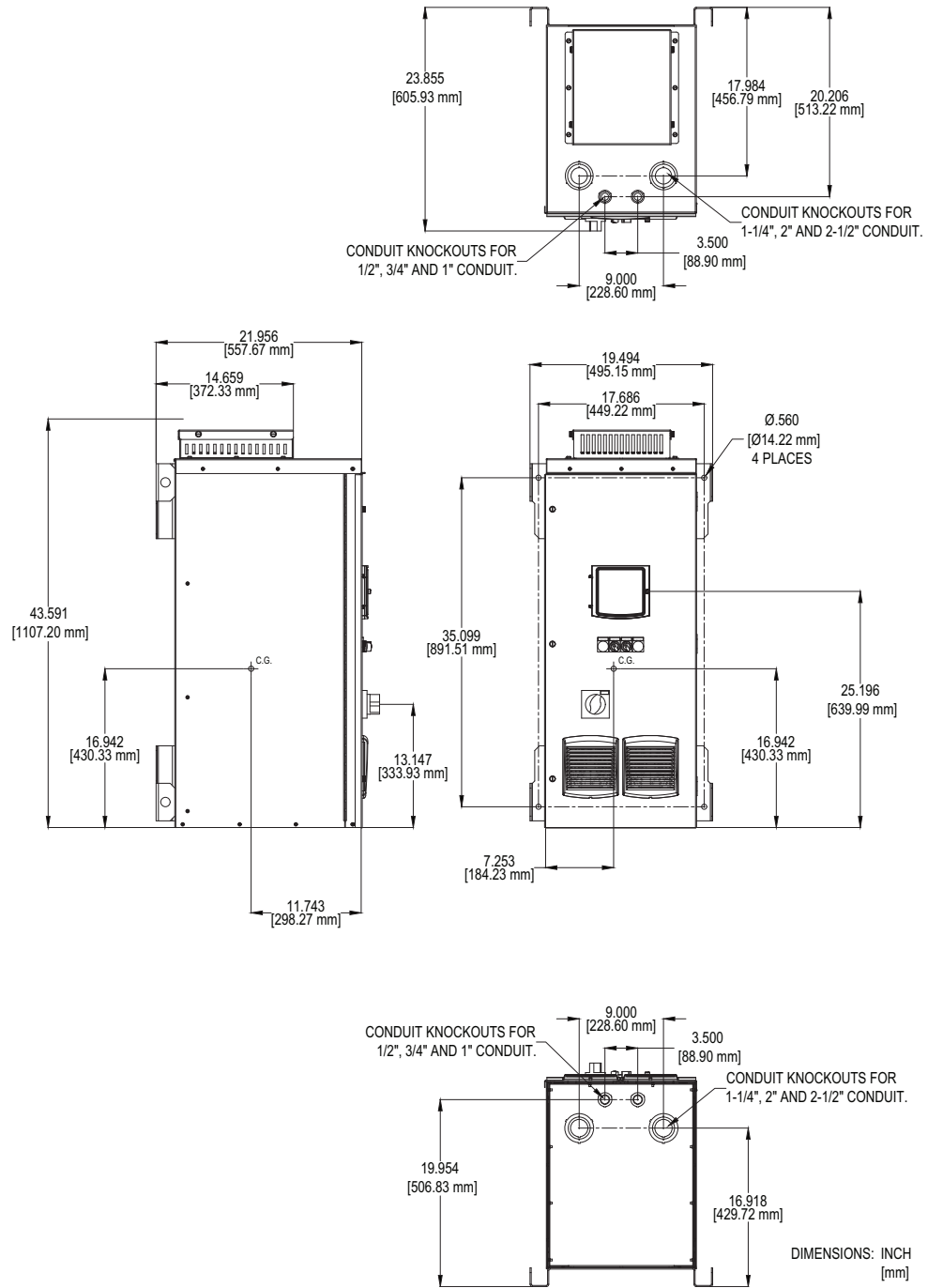




Figure 16 – Frame Size C, Type 12K: 15–30 hp @ 208/230 Vac and 20–40 hp @ 460 Vac

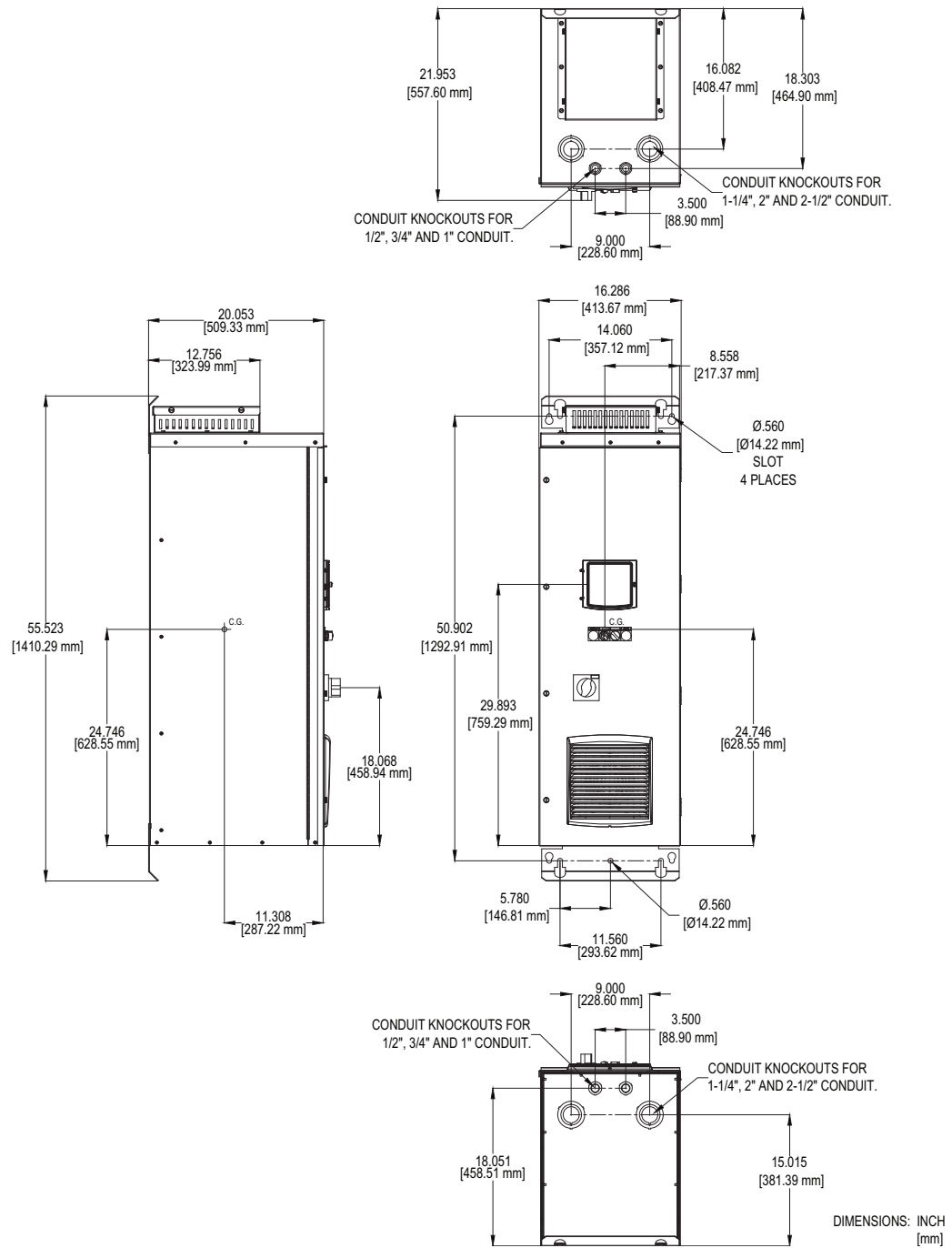


Figure 17 – Frame Size C, Type 12K Seismic: 15–30 hp @ 208/230 Vac and 20–40 hp @ 460 Vac

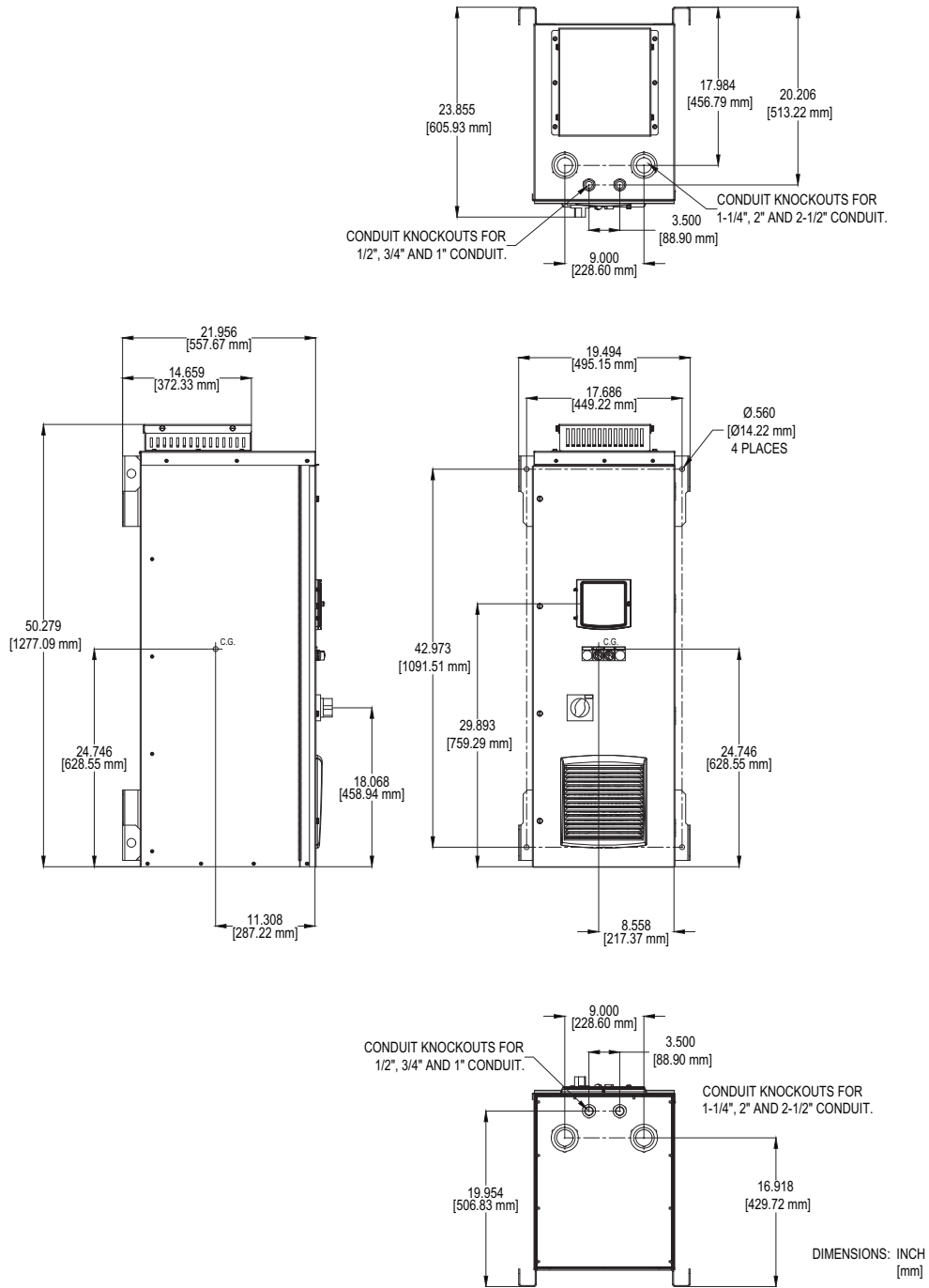


Figure 18 – Frame Size D, Type 12K: 40 hp @ 208/230 Vac and 50–100 hp @ 460 Vac

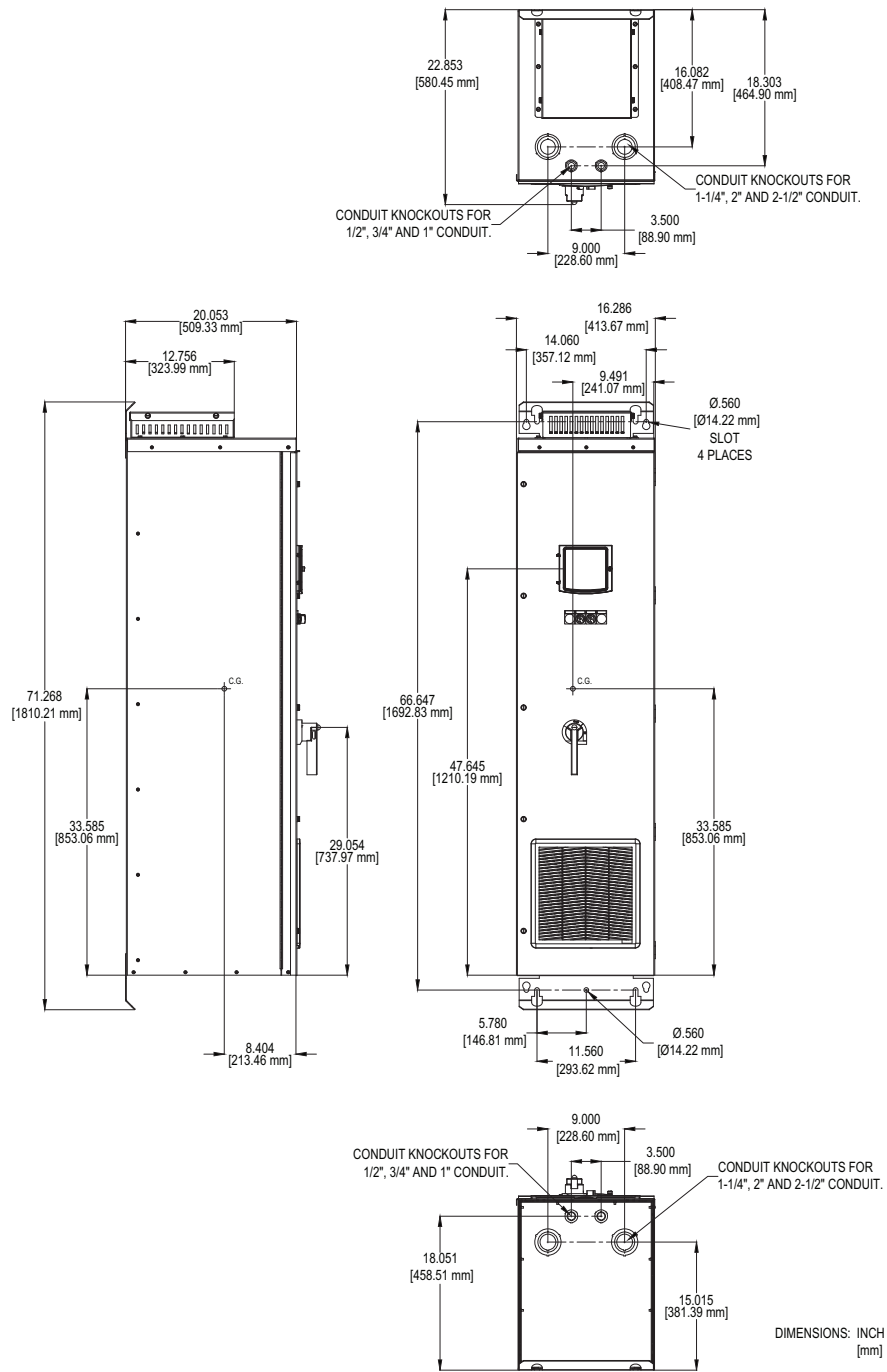


Figure 19 – Frame Size D, Type 12K Seismic: 40 hp @ 208/230 Vac and 50–100 hp @ 460 Vac

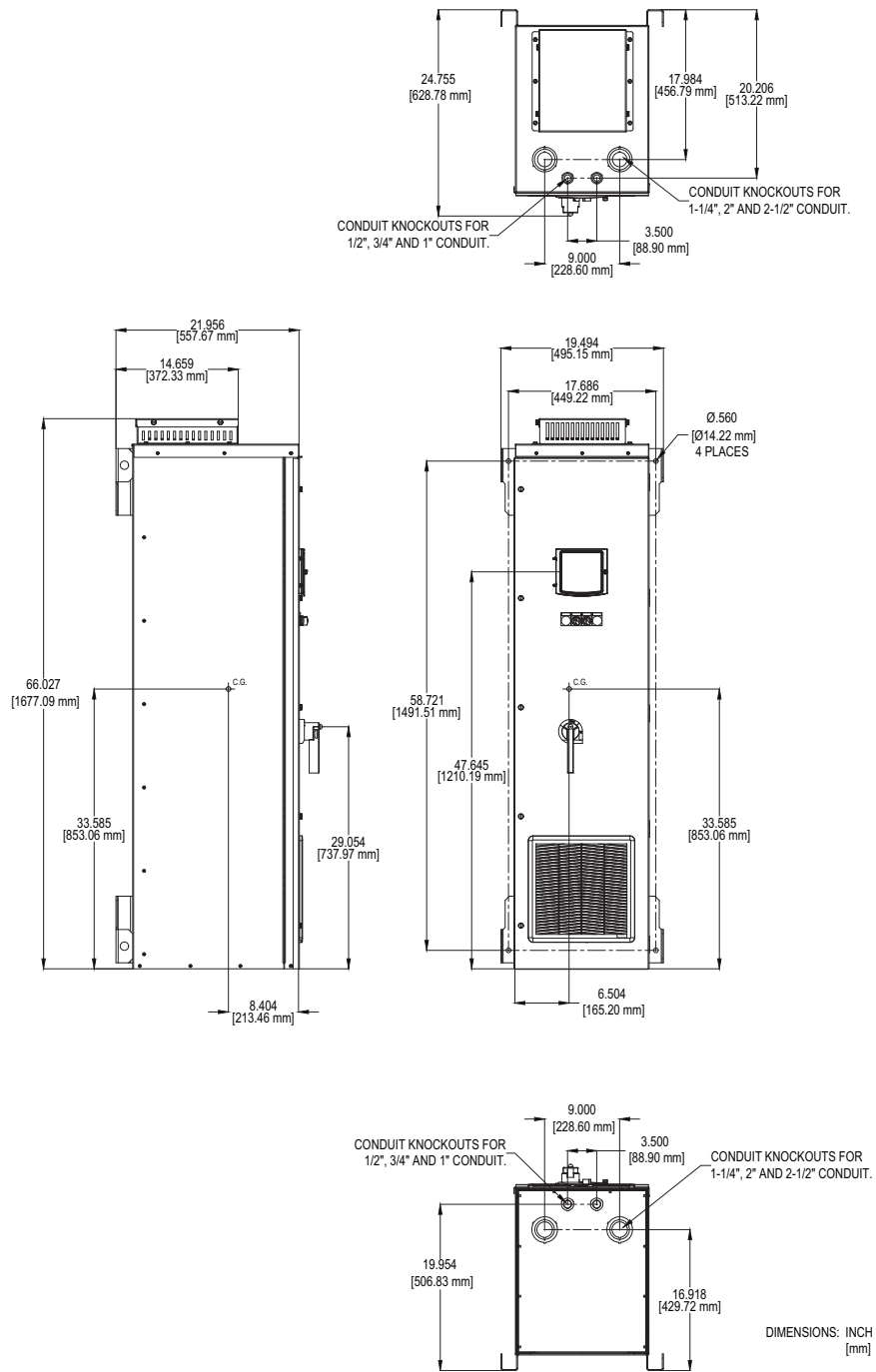


Figure 20 – Frame Size A, Type 3R: 1–5 hp @ 208/230 Vac and 1–7.5 hp @ 460 Vac

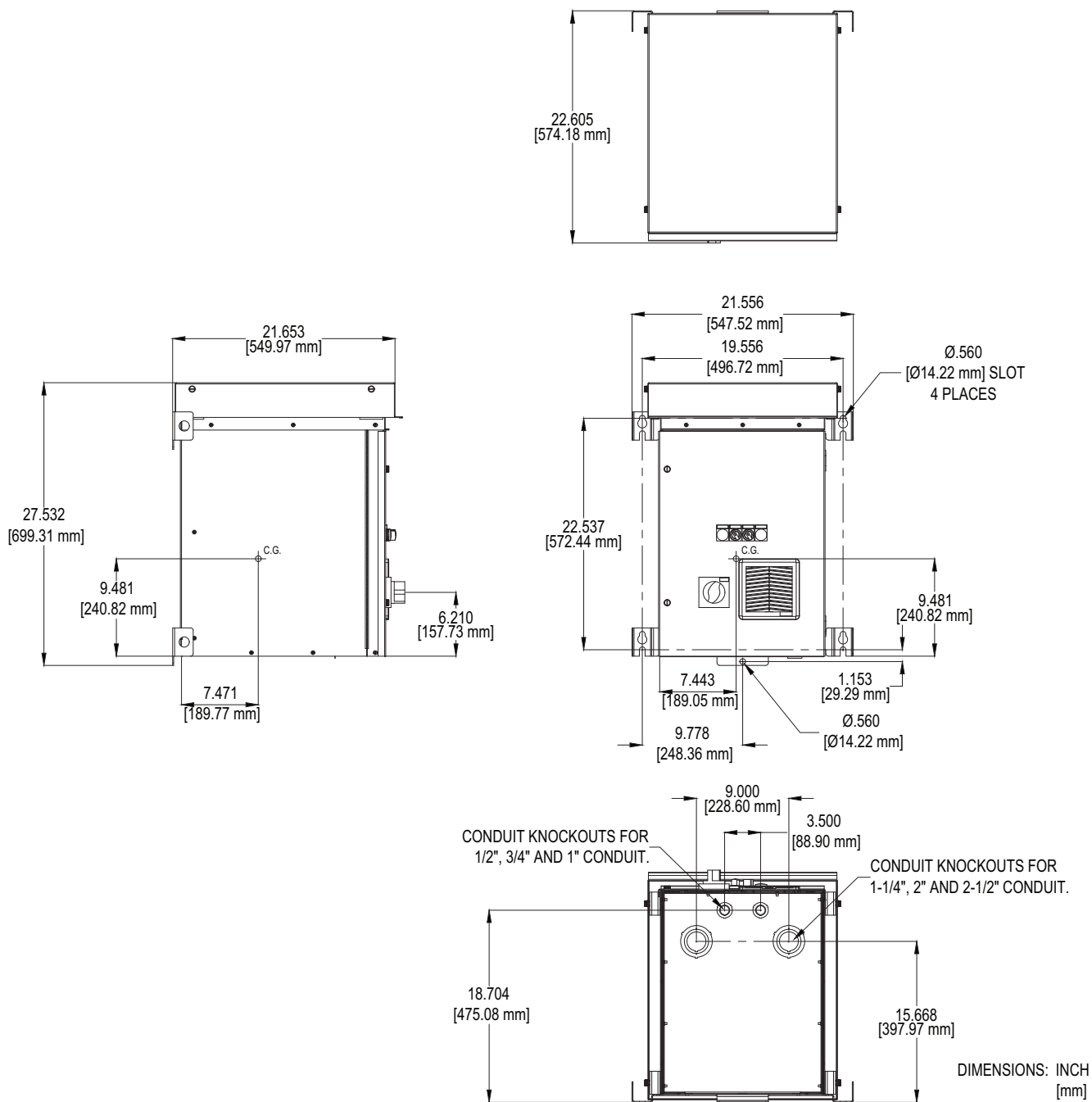


Figure 21 – Frame Size A, Type 3R Seismic: 1–5 hp @ 208/230 Vac and 1–7.5 hp @ 460 Vac

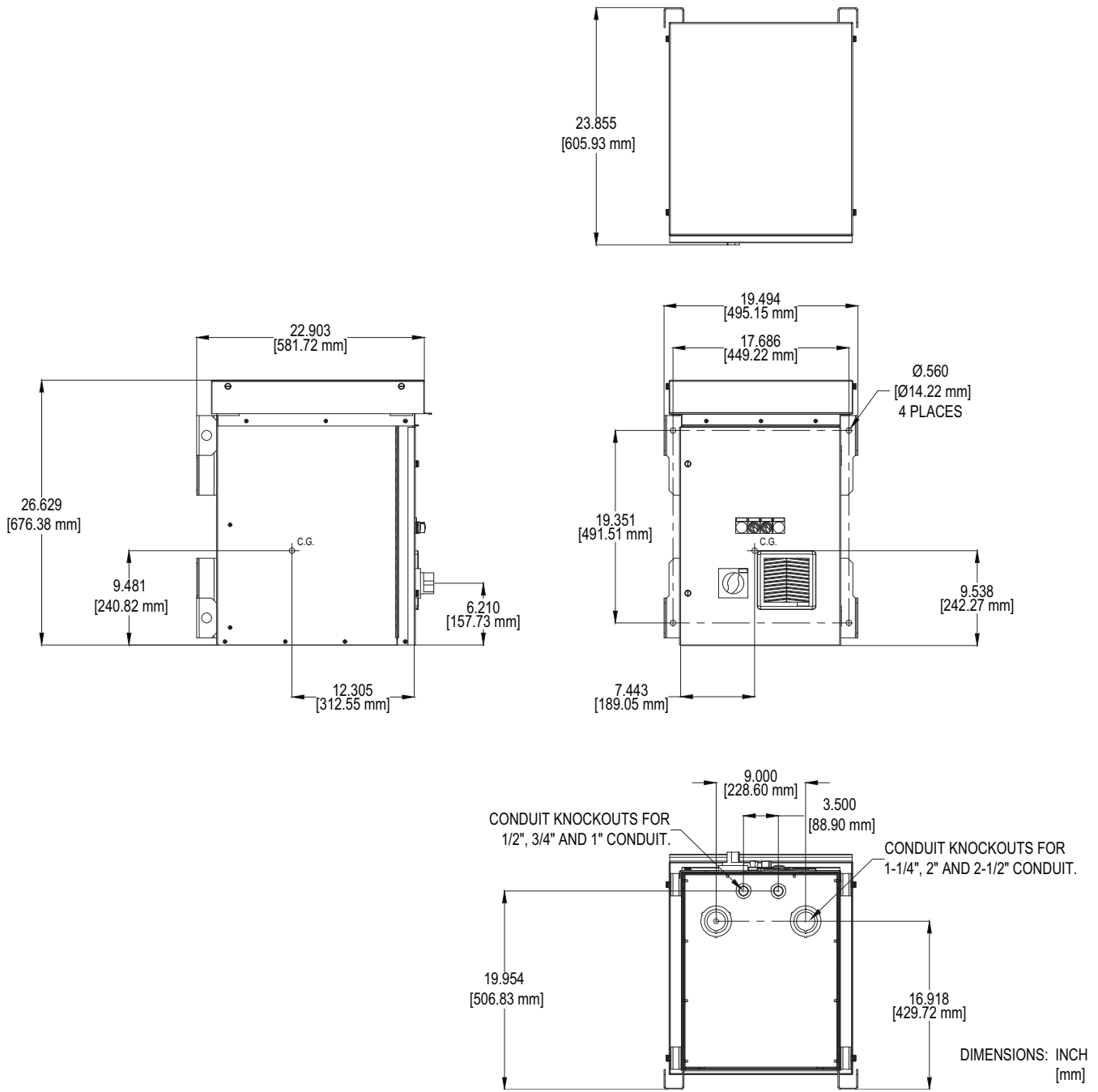
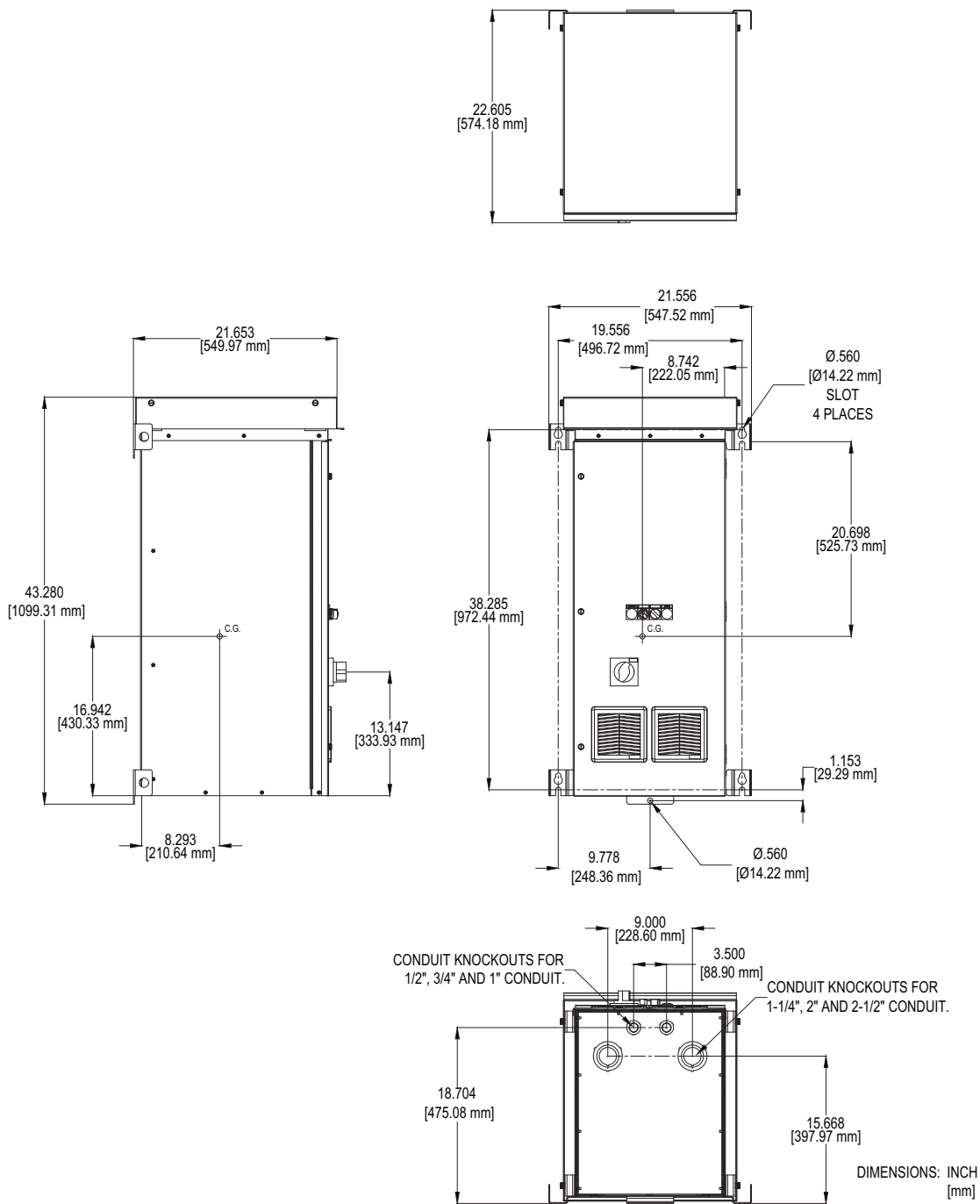


Figure 22 – Frame Size B, Type 3R: 7.5–10 hp @ 208/230 Vac and 10–15 hp @ 460 Vac



**Figure 23 – Frame Size B, Type 3R Seismic: 7.5–10 hp @ 208/230 Vac and 10–15 hp @ 460 Vac**

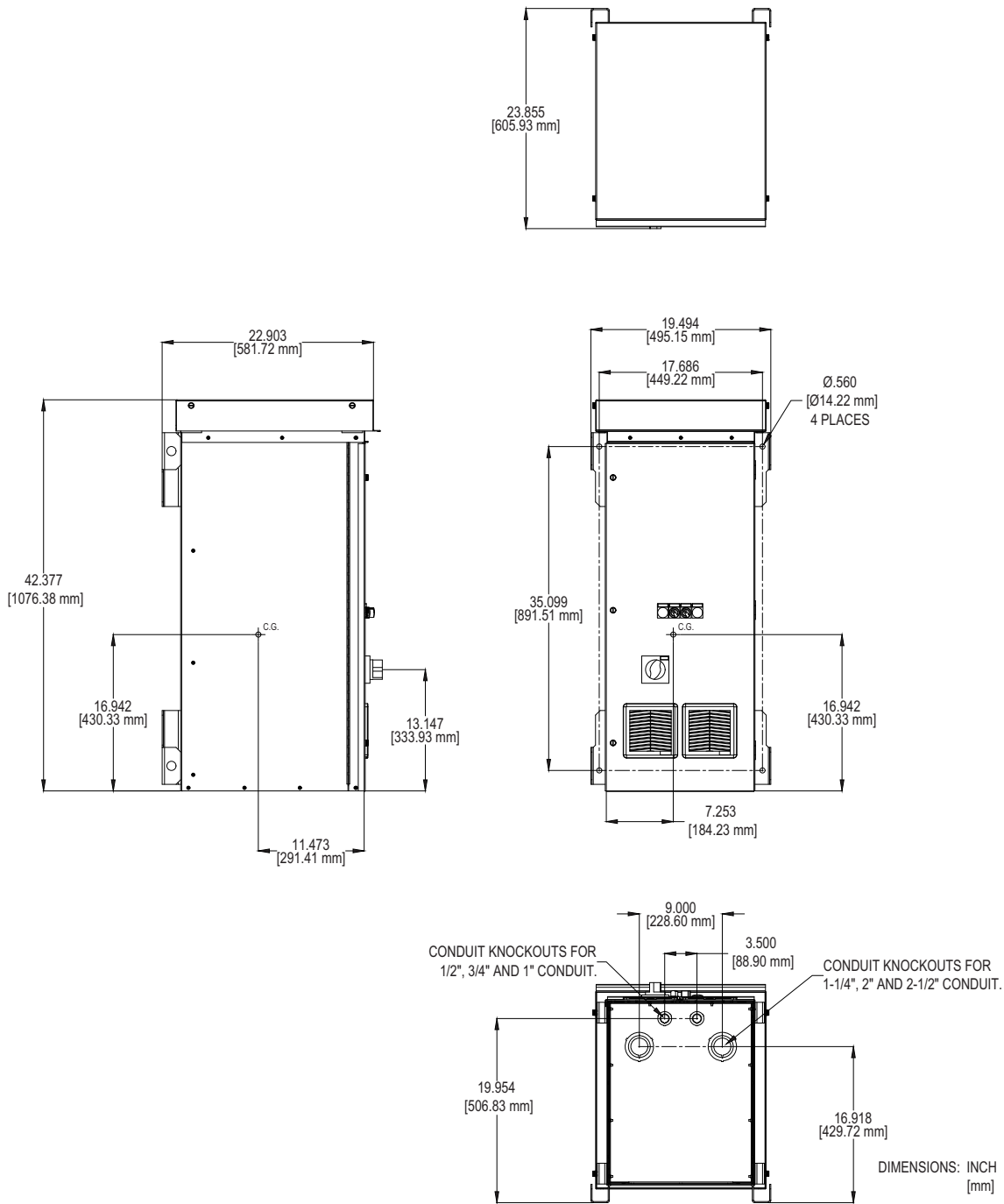




Figure 24 – Frame Size C, Type 3R: 15–30 hp @ 208/230 Vac and 20–40 hp @ 460 Vac

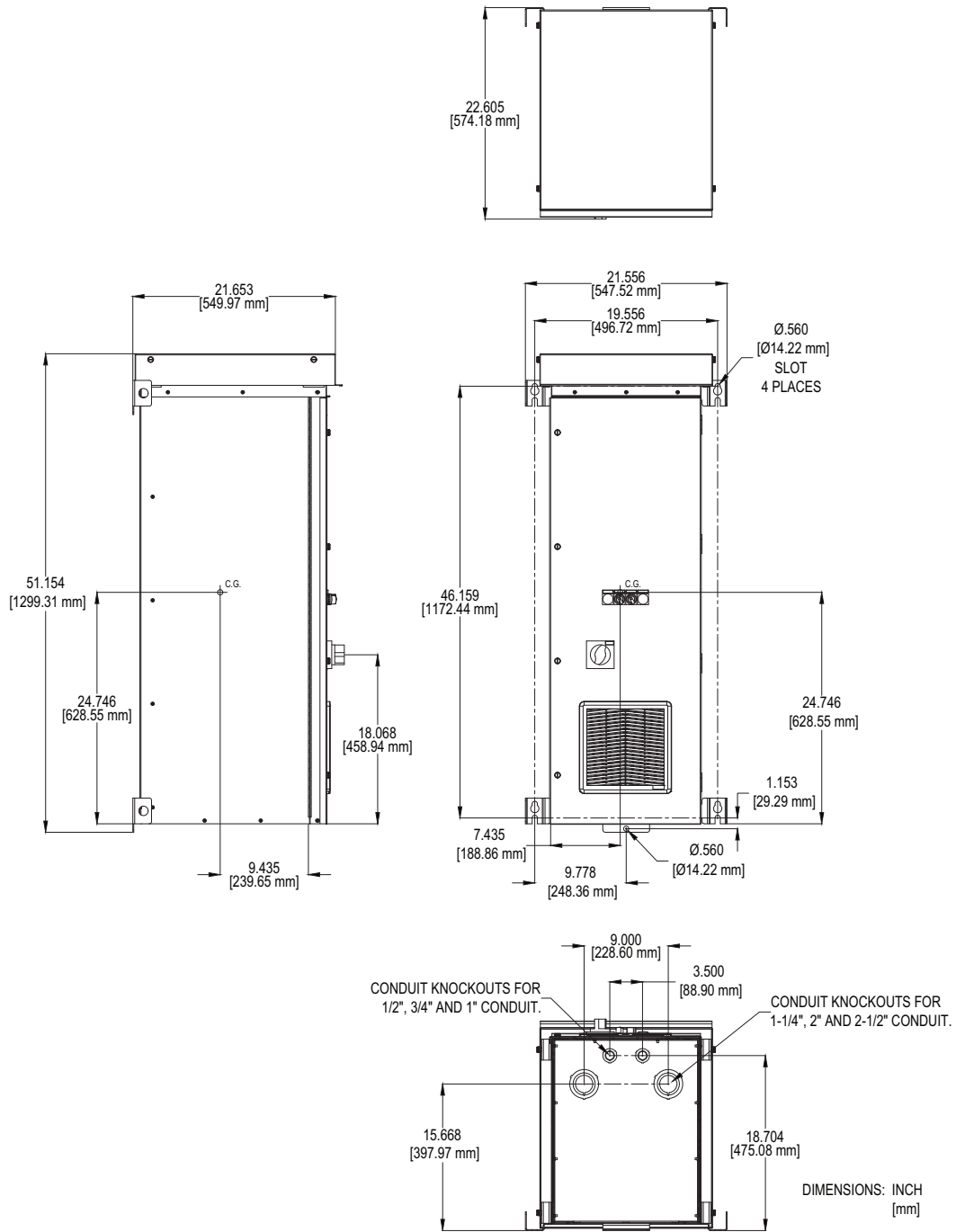


Figure 25 – Frame Size C, Type 3R Seismic: 15–30 hp @ 208/230 Vac and 20–40 hp @ 460 Vac

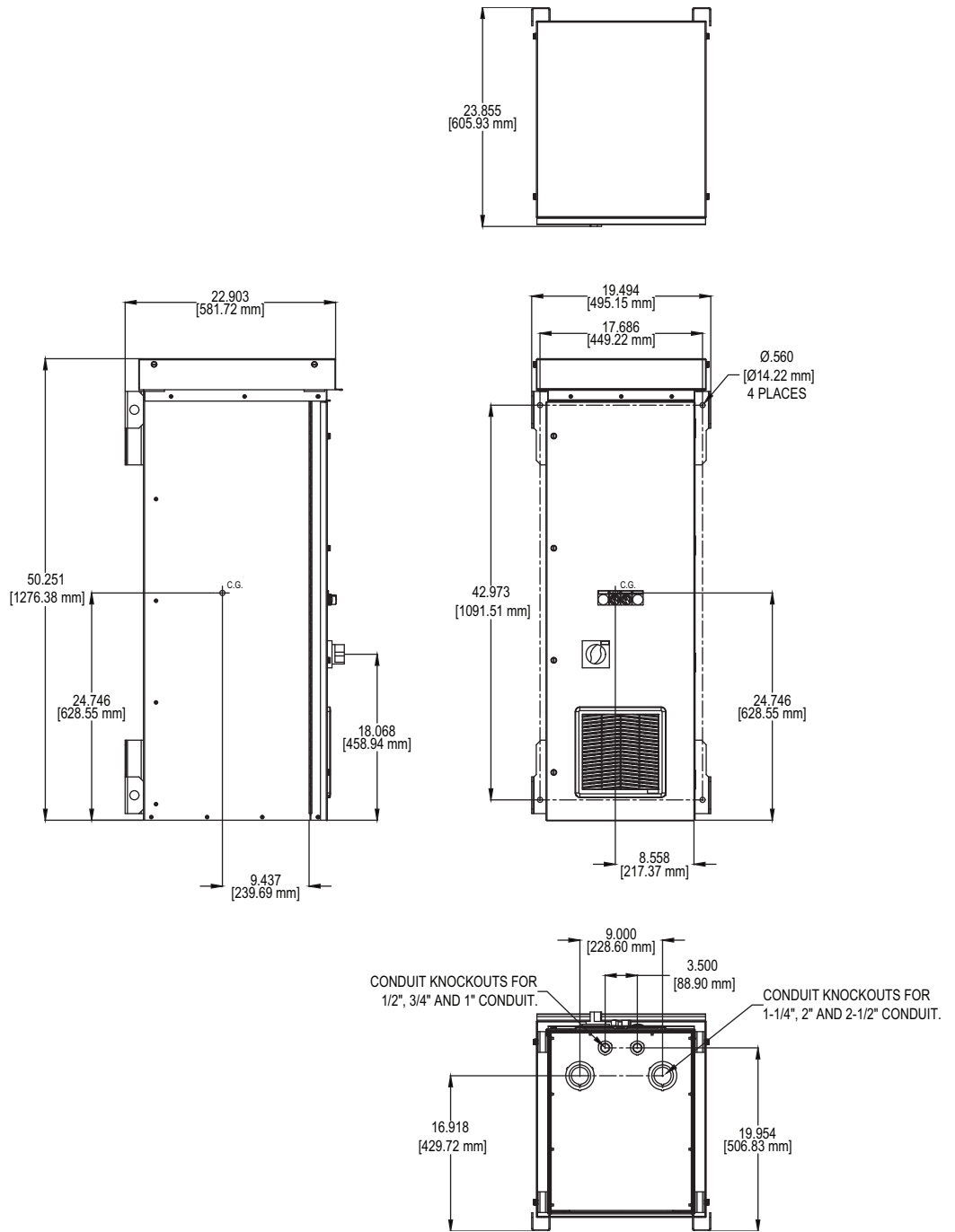


Figure 26 – Frame Size D, Type 3R: 40 hp @ 208/230 Vac and 50–100 hp @ 460 Vac

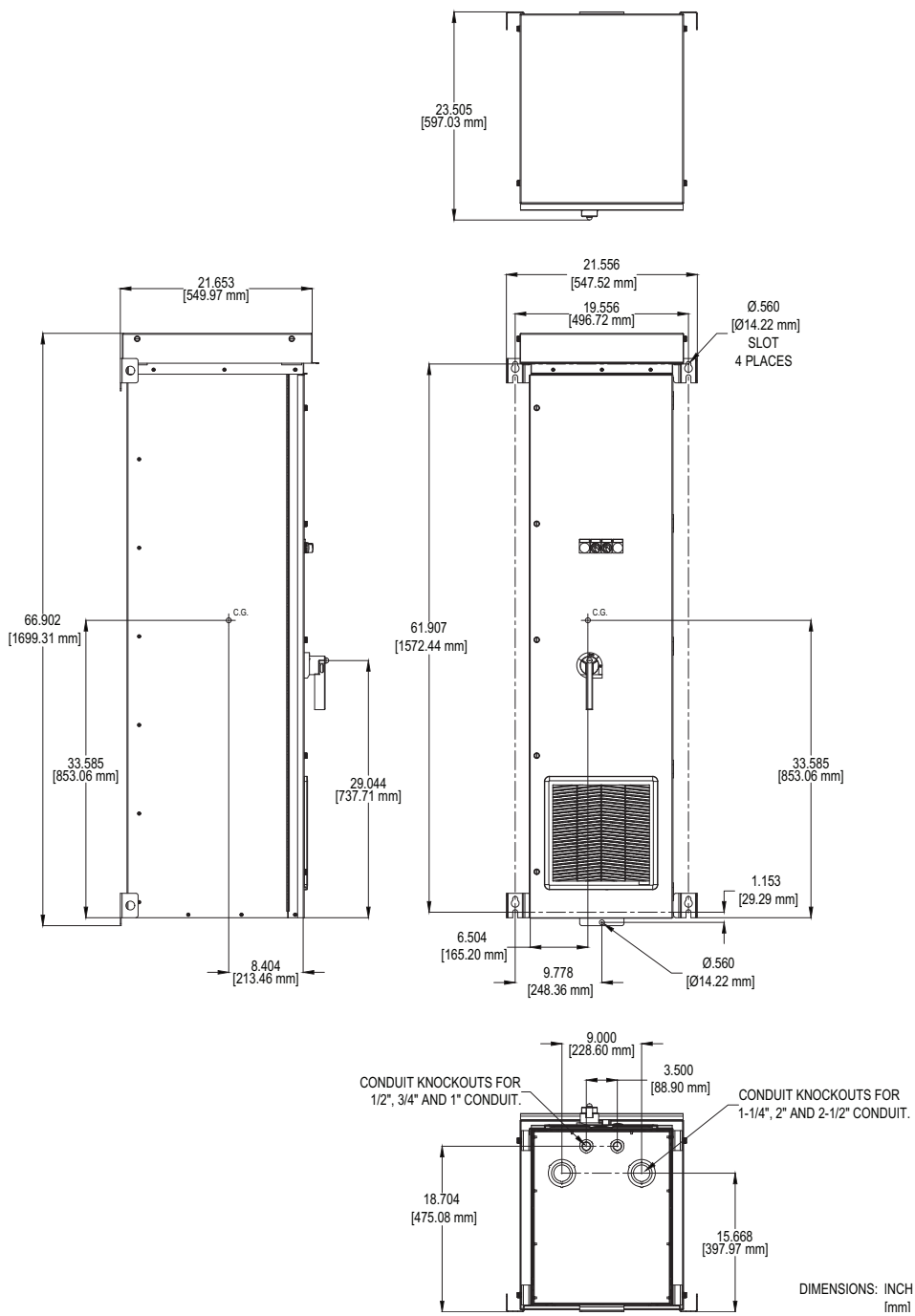
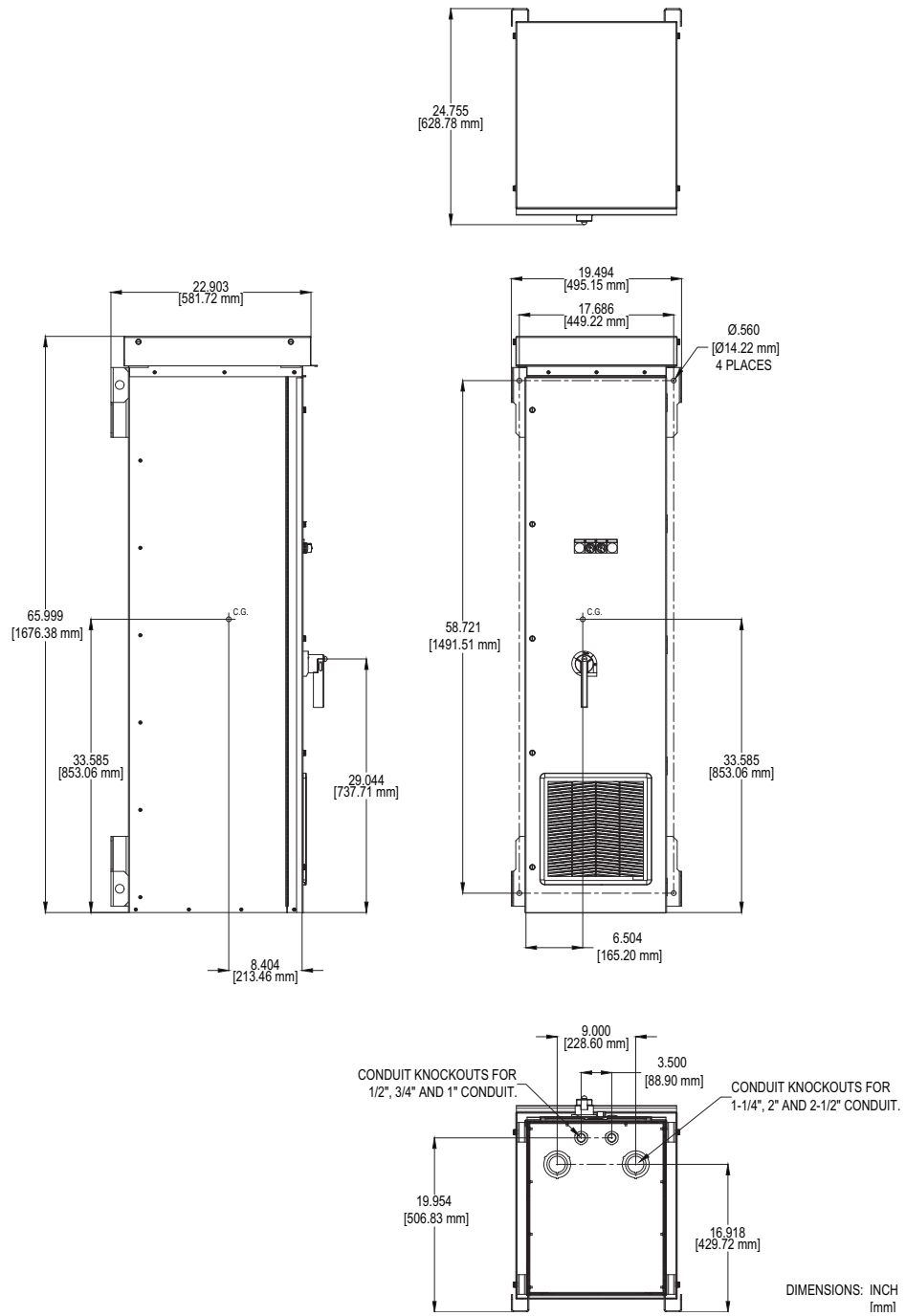


Figure 27 – Frame Size D, Type 3R Seismic: 40 hp @ 208/230 Vac and 50–100 hp @ 460 Vac



## Mounting Requirements

### **⚠ WARNING**

#### **IMPROPER MOUNTING**

Before removing the lifting mechanism:

- Ensure that all hardware is of sufficient size and type for the enclosed drive's weight.
- Secure and tighten all hardware.
- If using knockouts for conduit entry, exercise care to prevent metal or chips from falling on parts and electronic printed wiring boards.
- When cleaning the interior and exterior of the enclosed drive, use a vacuum. Do not use compressed air, as it may blow contaminants into other parts of the enclosed drive.
- Check the enclosure for damage that might reduce electrical clearances.
- See Figures 4–27 on pages 21–44 for mounting dimensions and clearances, and location of conduit entry areas.

**Failure to follow these instructions can result in death, serious injury, or equipment damage.**

Mount each device so that the door can be opened at least 90°. The following are spacing recommendations:

- Mount all units with a minimum of 6.0 in. (152 mm) of space to the top and bottom.
- Mount 1–40 hp 208/230 V and 1–60 hp 460 V units with a minimum of 3.5 in. (89 mm) of space to the left and right.
- Mount 75–100 hp 460 V units with a minimum of 4.0 in. (102 mm) of space to the left and right.

## Mounting on an EZM Mounting Channel (Type 1 Only)

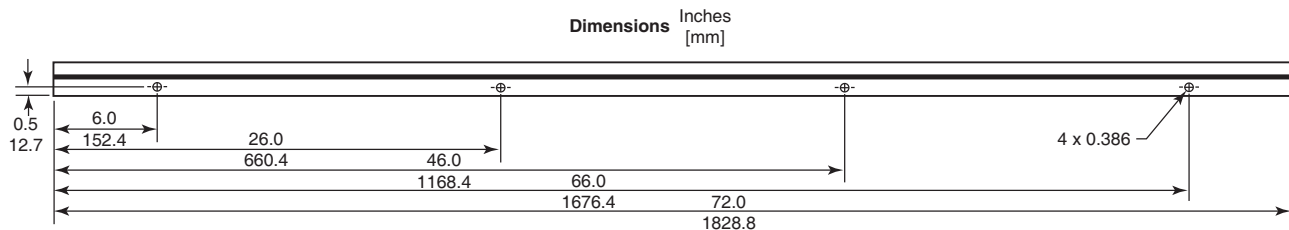
This section explains how to mount Type 1 enclosed drives on an EZM72MC mounting channel. This mounting method is available for:

- Frame size A enclosures: 1–15 hp @ 460 V, 1–10 hp @ 208/230 V
- Frame size B enclosures: 20–25 hp @ 460 V, 15–25 hp @ 208/230 V
- Frame size C enclosures: 30–60 hp @ 460 V, 30 hp @ 208/230 V

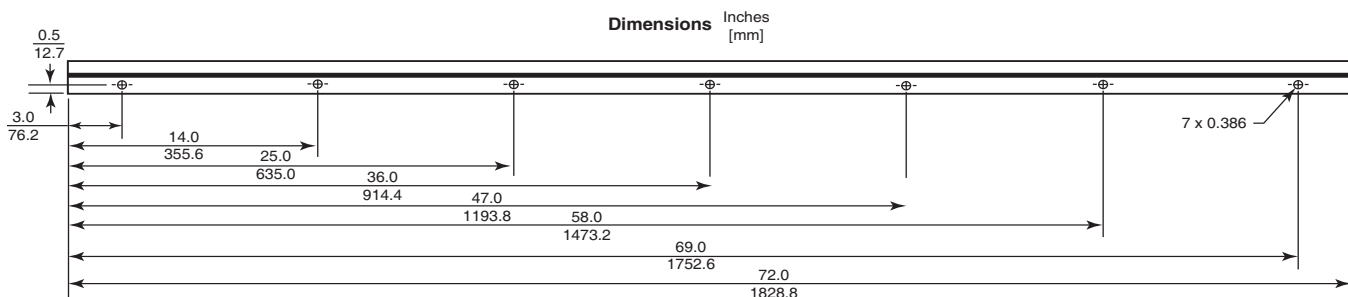
**NOTE:** EZM mounting cannot meet seismic requirements. Normal mounting methods must be used to meet seismic requirements.

The EZM channel is used to mount enclosures or assist in the alignment of multiple enclosures. Observe the following requirements for EZM mounting:

- Securely fasten the EZM mounting channel to a wall that is rated to support the total weight of the enclosed drives.
- Add additional wall anchor points to the EZM mounting channel as follows, with consideration given to wall construction:
  - **Frame size A enclosures only:** For a 72 in. long rail with a maximum of six size A enclosed drives, do not locate the rail anchor points more than 6 in. from each end, and do not allow more than 20 in. between each additional anchor point.

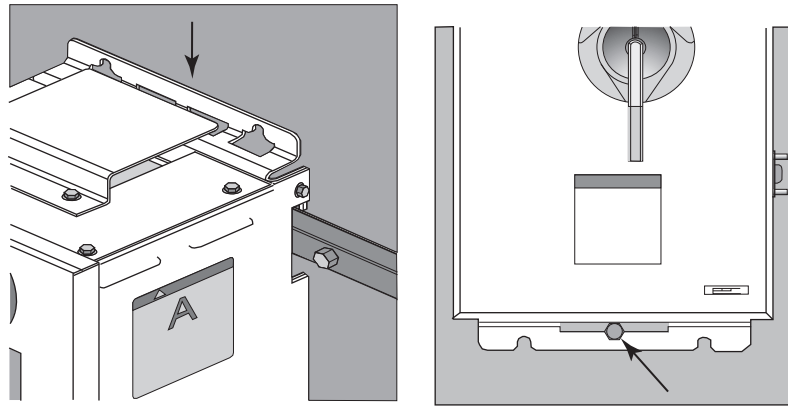


- **Frame size B and C enclosures:** For a 72 in. long rail with a maximum of four size B or C enclosed drives (or any combination of these enclosed drives), do not locate the rail anchor points more than 3 in. from each end, and do not allow more than 11 in. between each additional anchor point.



- Use SAE grade 5-3/8 in. or better hardware to secure the rail to the wall. Use additional anchor hardware if needed for the material used in the wall construction.
- Add additional 5/16 in. hardware to the bottom flange of the enclosure. See Figure 28.

Figure 28 – EZM Mounting Hardware



### Seismic Qualification Mounting Criteria

Seismic qualification (MOD S07) harmonizes the following standards in compliance to ICC ES AC156 acceptance criteria test protocol with an importance factor of 1.5:

- IBC (International Building Code)
- NFPA 5000 (Building Code-National Fire Protection Agency)
- CBC (Canadian Building Code)
- ASCE/SEI 7 (American Society of Civil Engineers)
- California Building Code

For seismic rating installation compliance:

- Follow the anchorage and mounting guidelines on the seismic qualification labels attached to the enclosed drive.
- For Type 1 enclosures, use SAE Grade 5 bolts and washers. For Type 12 and 3R enclosures, use SAE Grade 8 bolts and washers.
- Torque all bolts to applicable SAE standards, considering all plating and lubricant factors.

For additional information on Seismic qualification of enclosed drives, refer to instruction bulletin 30072-454-87, *Seismic Qualification of Enclosed Drives and Soft Starters*.

Figure 29 – Seismic Qualification Labels

<p><b>Certification Label</b></p> <div style="border: 1px solid black; padding: 10px;"> <p style="font-size: 24pt; font-weight: bold; margin: 0;">SEISMIC QUALIFIED</p> <p style="margin: 5px 0;">2003 IBC NFPA 5000 2001 CBC 1997 UBC 1999 NBC 1999 SBC ASCE-7 02</p> <div style="text-align: center;"> </div> <p style="font-size: 8pt; margin: 0;">80438-880-04 <span style="float: right;">REV -</span></p> </div>	<p><b>Wall Mounting</b></p> <div style="border: 1px solid black; padding: 10px;"> <div style="display: flex; align-items: center; justify-content: space-between;"> <div style="text-align: right;"> <p><b>Seismic Anchorage Requirements</b></p> <ul style="list-style-type: none"> <li>■ Seismic Anchorage Location</li> </ul> </div> </div> <p style="font-size: 8pt; margin-top: 10px;">To maintain Seismic Qualification each individual enclosure must be anchored to wall at all five mounting locations shown above. Refer to the current International Building Code or NFPA 5000 for location specific values of Ss. Use 5/16" grade 5 bolts and the appropriate flat washers. In order to develop full strength of the anchor, torque bolts to the value specified by the anchor manufacturer.</p> <p style="font-size: 8pt; margin-top: 5px;">Refer to Instruction Manual 30072-451-83 for installation instructions.</p> <p style="font-size: 8pt; text-align: right; margin-top: 10px;">80462-041-01 Rev -</p> </div>
--	---

## Electrical Installation

### **⚠ DANGER**

#### **HAZARD OF ELECTRIC SHOCK, EXPLOSION, OR ARC FLASH**

Turn off all power (main and remote) before installing the equipment. Refer to “Before You Begin” starting on page 8 for important information and precautions.

**Failure to follow these instructions will result in death or serious injury.**

## General Wiring Practices

Before wiring the enclosed drive, perform the DC Bus Voltage Measurement Procedure on page 56. Good wiring practice requires the separation of control circuit wiring from all power wiring. Power wiring to the motor must have the maximum possible separation from all other power wiring, whether from the same drive or other drives.

**Do not run power and/or control or multiple power wiring in the same conduit.** This separation reduces the possibility of coupling electrical transients from power circuits into control circuits or from motor power wiring into other power circuits.

### **⚠ CAUTION**

#### **IMPROPER WIRING HAZARD**

Follow the wiring practices described in this document in addition to those already required by the applicable national and local electrical codes.

**Failure to follow these instructions can result in injury or equipment damage.**

Follow the practices below when wiring the S-Flex enclosed drive:

- Use the supplied knockouts to feed control wiring into the cabinet. Do not run control wires through the enclosed drive vents or rear air intake.
- Use metallic conduit for all wiring. Do not run control and power wiring in the same conduit.
- Separate metallic conduits carrying power wiring or low-level control wiring by at least 3 inches (76 mm).
- Separate existing, non-metallic conduits or cable trays used to carry power wiring from metallic conduit carrying low-level control wiring by at least 12 inches (305 mm).
- Whenever power and control wiring cross, the metallic conduits and non-metallic conduits or trays must cross at right angles.
- Equip all inductive circuits near the enclosed drive (relays, contactors, solenoid valves) with noise suppressors.
- Tighten all electrical connections to their proper torque values. See the nameplate information for line and load torque values. Torque values are also listed in Tables 10 and 12 on pages 67 and 69.



## Input Power

The S-Flex enclosed drive operates from a three-phase supply connected to its input. The disconnect is coordinated and tested with the enclosed drive power circuit for a short-circuit current rating of 100,000 A.

## Branch Circuit Connections

Size all branch circuit components and equipment—such as feeder cables, disconnect devices, and protective devices—in accordance with national and local electrical codes based on the drive input current or motor full load current (whichever is greater).

The input current and the enclosed drive's rated FLA are printed on the nameplate (see Figure 1 on page 12). Refer to Table 3 on page 12 for the enclosed drive's input currents. Refer to Tables 10–12 (pages 67–69) for lug data and wire range of enclosed drive input terminals L1, L2, and L3.

Connect input power leads L1, L2, and L3 to the input of the circuit breaker or disconnect switch.

## Input Wiring

### **⚠ WARNING**

#### **IMPROPER OVERCURRENT COORDINATION**

- Properly coordinate all protective devices.
- Do not connect the enclosed drive to a power feeder whose short circuit capacity exceeds the short-circuit current rating listed on the enclosed drive's nameplate.

**Failure to follow these instructions can result in death or serious injury.**

### **⚠ CAUTION**

#### **EQUIPMENT DAMAGE FROM IMPROPER WIRING**

- Do not connect input power leads to the enclosed drive's output terminals (T1, T2, T3 or U, V, W). This damages the enclosed drive and voids the warranty.
- Check the power connections before energizing the enclosed drive.

**Failure to follow these instructions can result in injury or equipment damage.**

Size the ampacity of the input power conductors in accordance with national and local electrical codes based on the enclosed drive's input current or motor full load current (whichever is greater).

## Grounding

Ground the S-Flex enclosed drive in accordance with national and local electrical codes. To ground the enclosed drive:

- Connect a copper wire from the grounding bar terminal to the power system ground.
- Verify that the resistance to ground is 1  $\Omega$  or less. Improper grounding causes intermittent and unreliable operation.
- Do not remove any internal ground wires or connections.

### **⚠ DANGER**

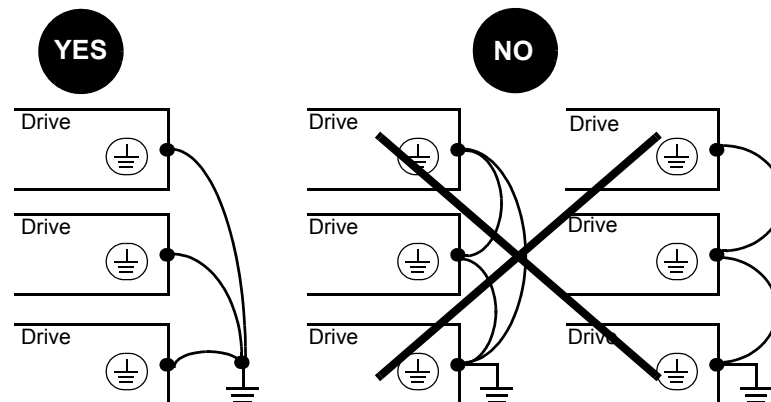
#### **HAZARD OF ELECTRIC SHOCK**

- Ground equipment using the provided grounding connection point as shown in Figure 31 (Type 1) or Figure 32 (Type 12K/3R) on pages 53–54. The drive panel must be properly grounded before power is applied.
- Do not use metallic conduit as a grounding conductor.

**Failure to follow these instructions will result in death or serious injury.**

Ground multiple enclosed drives as shown in Figure 30. Use one grounding conductor per device. Do not loop grounding conductors or install them in series.

**Figure 30 – Grounding Multiple Enclosed Drives**



## Connection to Ungrounded or High-Resistance Grounded Systems

### ⚠ CAUTION

#### EQUIPMENT DAMAGE FROM MAINS SERVICE CONFIGURATION

- The RFI filter ground connection must be removed when connecting the enclosed drive to a system supplied by an ungrounded delta, corner grounded delta, open delta, or resistance grounded delta transformer.
- When applying enclosed drives on open delta systems, measure the current imbalance at full load to confirm that the current imbalance does not exceed five percent.

**Failure to follow these instructions can result in injury or equipment damage.**

Altivar 212 480 V drives feature built-in radio frequency interference (RFI) filters with grounded capacitors. When applying the enclosed drive on an ungrounded delta, corner grounded delta, or open delta connected system, or on any resistance grounded system, isolate the RFI filters from ground to help prevent reduction of their operating life.

Refer to the *Altivar 212 Installation Guide*, S1A53832, for information on disconnecting the filter ground. The installation manual is available online at [www.schneider-electric.com](http://www.schneider-electric.com).

A system supplied by an open delta transformer may be susceptible to voltage fluctuations and current imbalance, which can damage the enclosed drive and other connected equipment.

- Exercise care when applying equipment on a power system where the voltage is derived in this way.
- To reduce the potential for a current imbalance, always include a line reactor option with the enclosed drive.
- During commissioning, measure the input current at full load to confirm that the current imbalance does not exceed five percent.
- If the imbalance exceeds five percent, discontinue use of the equipment and contact technical support.

## Wiring and Electromagnetic Compatibility

### **▲ WARNING**

#### **LOSS OF CONTROL**

- The designer of any control scheme must consider the potential failure modes of control paths and, for certain critical control functions, provide a means to achieve a safe state during and after a path failure. Examples of critical control functions are emergency stop and over travel stop.
- Separate or redundant control paths must be provided for critical control functions.
- System control paths may include communication links. Consideration must be given to the implications of anticipated transmission delays or failures of the link<sup>1</sup>.
- Each implementation of a S-Flex enclosed drive must be individually and thoroughly tested for proper operation before being placed into service.

**Failure to follow these instructions can result in death, serious injury, or equipment damage.**

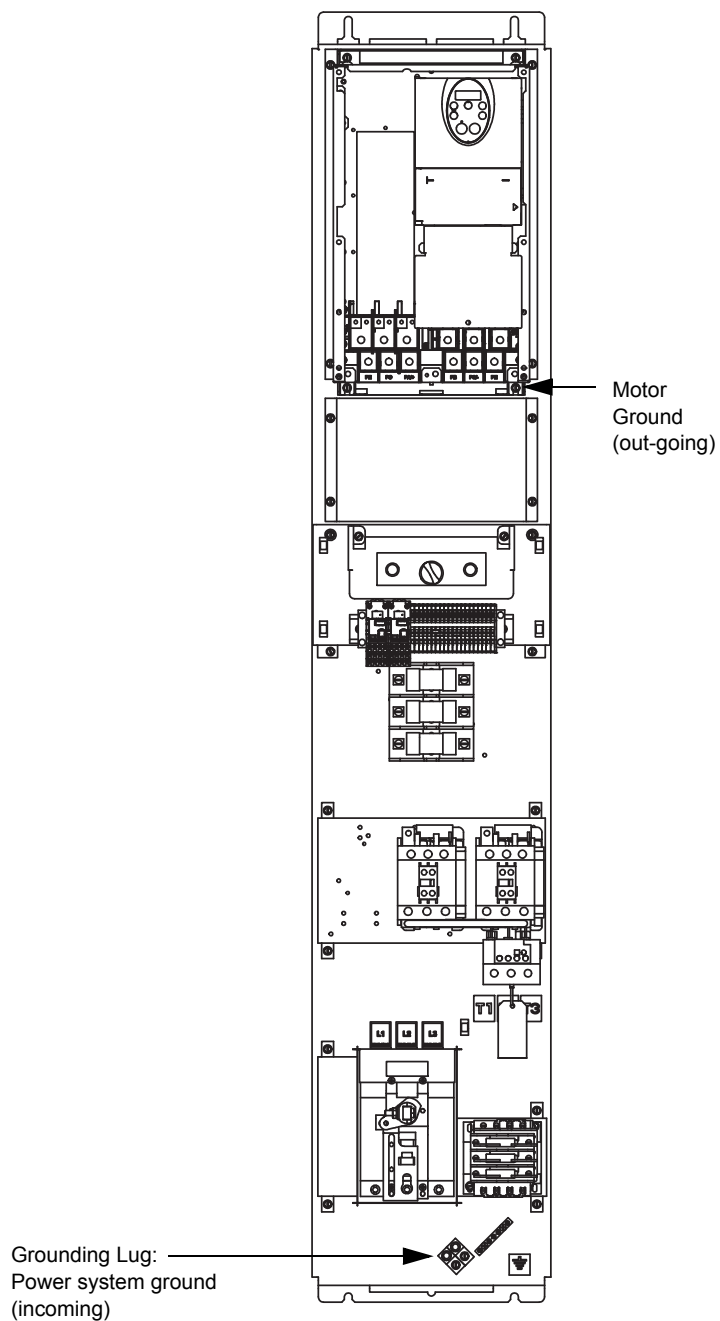
<sup>1</sup> For additional information, refer to NEMA ICS 1.1 (latest edition), “Safety Guidelines for the Application, Installation, and Maintenance of Solid State Control” and to NEMA ICS 7.1 (latest edition), “Safety Standards for Construction and Guide for Selection, Installation and Operation of Adjustable-Speed Drive Systems.”

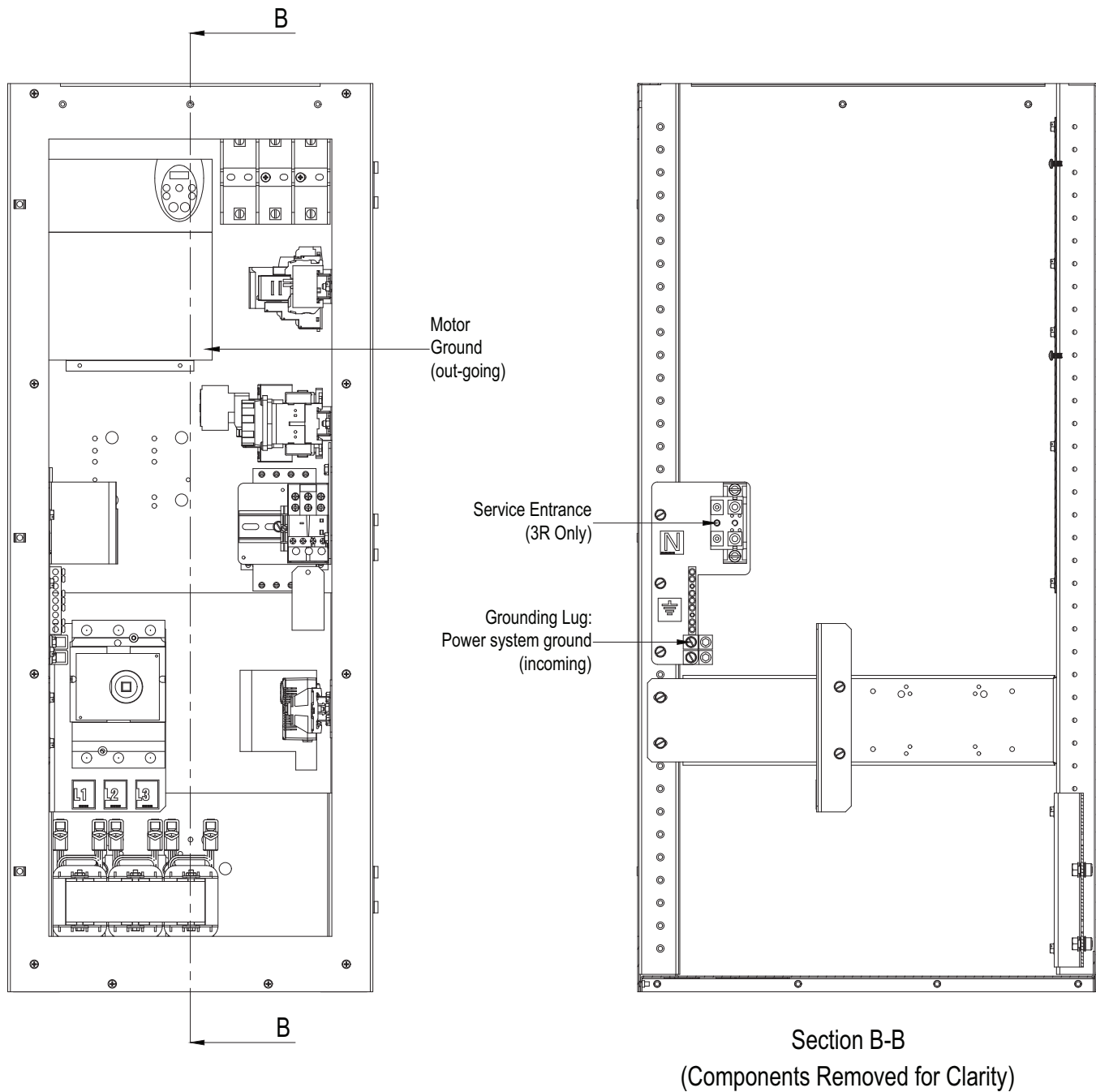
The high frequency equipotential grounding connection between the drive, motor, and cable shielding does not eliminate the need to connect the grounding (PE) conductors (green-yellow) to the appropriate terminals on each unit. To help accomplish this, follow these guidelines:

- To avoid communication interference, grounds between the drive, motor and cable shields must have high frequency equipotentiality.
- When using shielded cable for the motor, use a 4-conductor cable so that one wire will be the grounding connection between the motor and the drive. Size the grounding conductor in compliance with local and national codes. The shield can then be grounded at both ends. Metal ducting or conduit can be used for part or all of the shielding length, provided there is no break in continuity.
- When using shielded cable for control signals, if the cable is connecting equipment that is close together and the grounds are bonded together, then both ends of the shield can be grounded. If the cable is connected to equipment that may have a different ground potential, then ground the shield at one end only to prevent large currents from flowing in the shield. The shield on the ungrounded end may be tied to ground with a capacitor (for example: 10 nF, 100 V or higher) in order to provide a path for the higher frequency noise.
- Ensure maximum separation between the power supply cable (line supply) and the motor cable and also ensure maximum separation between the control cables and any power cables.

Connecting the motor ground wire directly to the power converter chassis as shown in Figure 31 (Type 1) or Figure 32 (Type 12K/3R) on pages 53–54 is the preferred grounding method. This method reduces the amount of high frequency noise generated by the power converter PWM that may be coupled into communication or control wiring. The drive has two or more marked terminals for making grounding connections.

Figure 31 – Generic Type 1 Grounding Connection Diagram



**Figure 32 – Type 12K/3R Grounding Connection Diagram**

## Output Wiring

Size the ampacity of motor power conductors according to the motor full load current and in accordance with national and local electrical codes.

Connect motor conductors to the lugs provided and connect the motor ground to the power converter chassis. Connect motor conductors to T1, T2, and T3 on the overload relay when the enclosed drive is supplied with a bypass circuit. Connect motor conductors to T1/U, T2/V, and T3/W on the power converter, or T1, T2, and T3 on the distribution block (if supplied), when the enclosed drive is supplied without a bypass circuit. See Figure 33 on page 60.

**NOTE:** For applications where output cable length exceeds 164 feet (50 meters), consult Schneider Electric.

The drive is sensitive to the amount of capacitance (either phase-to-phase or phase-to-ground) present on the output power conductors. If excessive capacitance is present, the drive may trip on overcurrent.

**Output Cable**

Follow these guidelines when selecting output cable:

- Cable type: select cable with a low capacitance phase-to-phase and to ground. Do not use mineral-impregnated cable because it has a very high capacitance. Immersion of cables in water increases capacitance.
- Cable length: the longer the cable, the greater the capacitance. Cable lengths greater than 164 ft (50 m) may appear as a ground fault condition to the drive. For installations where cable capacitances may be a problem, a reactor or motor protection filter can be installed between the drive and the motor.

The following guidelines are designed to address maximum cable length for typical drive/motor applications.

These limits are based on the maximum recommended peak voltage that can be allowed at the motor terminals, which is due to the reflected wave phenomenon. This increase in voltage is primarily determined by the degree of impedance mismatch between the power conductor and the motor in combination of the dV/dt of the specific semiconductors used in the inverter section of the drive feeding the motor, both of which vary depending on the horsepower involved.

- Many variables can affect the performance of the drive, the motor, and the cables in long lead applications. Motor protection filters can provide substantial benefits when you are using:
  - 460 V or higher rated AC drives
  - Existing general purpose motors subject to retrofit to an AC drive
  - Shielded cables
- NEMA MG-1 Part 31 compliant motors are recommended but not required. However, consult the motor manufacturer or vendor literature to address any specific limitations governing the application.
  - Proximity to other output cables: because of high frequency switching and increased capacitance, the drive may trip under some conditions.
  - **Do not use lightning arrestors or power factor correction capacitors on the output of the drive.**

For proper drive short circuit protection, certain values of inductance may be required in the output power wiring. Inductance can be supplied by the power wiring or auxiliary inductors.

<b>⚠ CAUTION</b>
<p><b>INSUFFICIENT OUTPUT INDUCTANCE</b></p> <p>Provide at least 500 mm (20 in.) of cable at the drive output (U/T1, V/T2, W/T3) to help protect the drive output when short circuits occur.</p> <p><b>Failure to follow these instructions can result in injury or equipment damage.</b></p>

## DC Bus Voltage Measurement Procedure

### **⚠ DANGER**

#### **HAZARD OF ELECTRIC SHOCK, EXPLOSION, OR ARC FLASH**

- Read and understand the DC Bus Voltage Measurement Procedure before performing the procedure.
- Measurement of bus capacitor voltage must be performed by qualified personnel.
- Apply appropriate personal protective equipment (PPE) and follow safe electrical work practices. See NFPA 70E®, CSA Z462, NOM-029-STPS, and other applicable regulations defining safe electrical work practices.
- DO NOT short across terminals PA/+ and PC/- or across the DC bus capacitors.
- DO NOT touch unshielded components or terminal strip screw connections with voltage present.
- Use only electrically insulated tools.
- Before servicing the enclosed drive:
  - Disconnect all power including external control power that may be present.
  - Always use a properly rated voltage sensing device to confirm power is off.
  - Place a “DO NOT TURN ON” label on all power disconnects.
  - Lock all power disconnects in the open position.
  - WAIT 15 MINUTES to allow the DC bus capacitors to discharge. Then follow the DC Bus Voltage Measurement Procedure below to verify that the DC voltage is less than 42 V. The drive LED is not an indicator of the absence of DC bus voltage.
- Replace all devices, doors, and covers before turning on power to this equipment or starting and stopping the enclosed drive.

**Failure to follow these instructions will result in death or serious injury.**

The DC bus voltage level is determined by monitoring the PA/+ and PC/- terminals. The location of these terminals varies by power converter model number. Read the model number of the power converter from the nameplate, and identify the corresponding PA/+ and PC/- terminals. See Figure 1 on page 12.

To measure the DC bus capacitor voltage:

1. Remove all power from the enclosed drive. Use a properly rated voltage sensing device to confirm power is off. Also, be sure to remove all external control power that may be present such as on the control board and the option board terminals.
2. Open the disconnect between the input line and the enclosed drive. Lock the disconnect in the open position and install a “Do Not Turn On” sign. Open the circuit breaker disconnect located on the front of the enclosed drive. Be sure to remove all external control power that may be present, such as on the control board and the option board terminals.
3. Wait fifteen minutes for the DC bus capacitors to discharge.
4. Open the door of the enclosed drive.
5. Set the voltmeter to the 1000 Vdc scale. Measure the voltage between the PA/+ and PC/- terminals.



6. Verify that the DC bus voltage has discharged below 42 V before servicing the drive. If the DC bus capacitors will not discharge below 42 V, contact your local Schneider Electric representative. **Do not operate the drive.**
7. After servicing the enclosed drive, close and secure door.

## Wire Routing and Interconnection

### Wire Class

The Wire Class describes the compatibility of the field wiring terminal with the conductor material and insulation system. When used in conjunction with the required conductor current rating and the enclosed drive ambient temperature rating, the Wire Class forms the basis for selecting a conductor size that limits the temperature on the conductor insulation at the field wiring terminal to acceptable limits. Conductors with operating temperatures exceeding those given by the Wire Class can be used, but the conductor size must be selected based on the Wire Class limits.

### Noise Class

The Noise Class categorizes the electromagnetic properties of the voltages and currents present. The six Noise Class categories determine proper wiring methods and physical segregation.

#### Quiet Wiring 1 (QW1)

*High-susceptibility analog and digital control signals.* Signals falling under the classification of QW1 include digital communication/network circuits, enclosed drive analog I/O and analog process signals.

#### Quiet Wiring 2 (QW2)

*Medium-susceptibility analog and digital control signals.* Signals falling under the classification of QW2 include 24 Vdc and 24 Vac control circuits.

#### Standard Wiring 1 (SW1)

*Low-Susceptibility control or power circuits rated less than 600 Vac (250 Vdc) and less than 15 A* (voltage and current spectra are generally contained within 0.05–9 kHz). Signals falling under the classification of SW1 include 120 Vac control circuits.

#### Standard Wiring 2 (SW2)

*Power circuits rated greater than 15 A* (voltage and current spectra are generally contained with 0.05–9 kHz). Signals falling under the classification of SW2 include line power to enclosed drives.

#### Standard Wiring 3 (SW3)

Reserved.

#### Pulse Wiring 1 (PW1)

*Control or power circuits whose voltage or current spectra significantly exceed 9 kHz.* Signals falling under the classification of PW1 include motor and dynamic braking circuits fed from PWM (pulse width modulation) power converters.

### Voltage Class

The Voltage Class groups the voltages present into recognized conductor insulation categories (30, 150, 300, and 600 V) for selection of conductor insulation voltage rating and physical segregation.

## Wiring Methods

### **⚠ DANGER**

#### **HAZARD OF ELECTRIC SHOCK, EXPLOSION, OR ARC FLASH**

- Route and secure all conductors to prevent damage to insulation when installing them under or near sharp edges.
- When possible, use jacketed conductors.

**Failure to follow these instructions will result in death or serious injury.**

Based on the Noise Class and Voltage Class of the conductors, apply the wiring methods in Table 8 to the enclosed drive.

**Table 8 – Wire Routing and Interconnection**

Wiring Methods and Considerations	Noise Class of Conductors <sup>1</sup>				
	QW 1	QW 2	SW 1	SW 2	PW 1
<b>Conductor Grouping in Wireways and Conduits</b>					
1. Bundle all conductors of 1- or 3-phase AC power circuits to minimize stray magnetic fields.			X	X	X
2. Bundle all conductors of a DC power circuit to minimize stray magnetic fields.			X	X	X
3. When parallel conductors must be run in separate wireways or conduit, bundle the conductors into groups to minimize stray magnetic fields.				X	X
4. Maintain conductor runs that are as short and direct as possible.	X	X	X	X	X
<b>Separation of Circuits</b>					
1. Do not run different Noise Class conductors in the same conduit.	X	X	X	X	X
2. Do not run different Voltage Class conductors in the same conduit unless all conductors are insulated for the maximum Voltage Class present.	X	X	X	X	X
3. Separate all conductors by Noise Class. Use the following circuit separation when conductors run parallel for more than 12 inches.					
• Metallic conduit: 3 in. from QW to SW or PW	X	X	X	X	X
• Metallic tray: 3 in. from SW to PW			X	X	X
• Metallic tray: 6 in. from QW to SW or PW	X	X	X	X	X
• Against continuous metal surface: 3 in. from SW to PW			X	X	X
• Against continuous metal surface: 6 in. from QW to SW or PW	X	X	X	X	X
• Metallic conduit housing QW: 12 in. to non-metallic conduit SW or PW	X	X	X	X	X
• Non-metallic conduit: 3 in. from SW to PW			X	X	X
• Non-metallic conduit: 23 in. from QW to SW or PW	X	X	X	X	X
4. All PW conductor groups must be individually separated using metallic conduit.					X
5. If QW and SW1 wiring must cross SW2 or PW1 wiring, cross the bundles at right angles.	X	X	X	X	X
<b>Common Mode Noise Issues</b>					
1. Provide adjacent signal returns using twisted pair cable.	X	X			
2. Galvanically isolate the signal and the associated signal return path when possible.	X	X			
<b>Shielding</b>					
1. Use metallic conduit for all power and control circuits external to the enclosed drive's enclosure.	X	X	X	X	X
2. Use shields that are continuous and equipped with a drain wire.	X	X	X		
3. Do not group different Noise Class conductors within the same shield.	X	X	X	X	X
4. Minimize the non-shielded portion of the conductor at the end of the shielded cable.	X	X	X	X	X
5. When shielding AC or DC power conductors, group the conductors to minimize the magnetic field in the shield.			X	X	X

**Table 8 – Wire Routing and Interconnection** *(continued)*

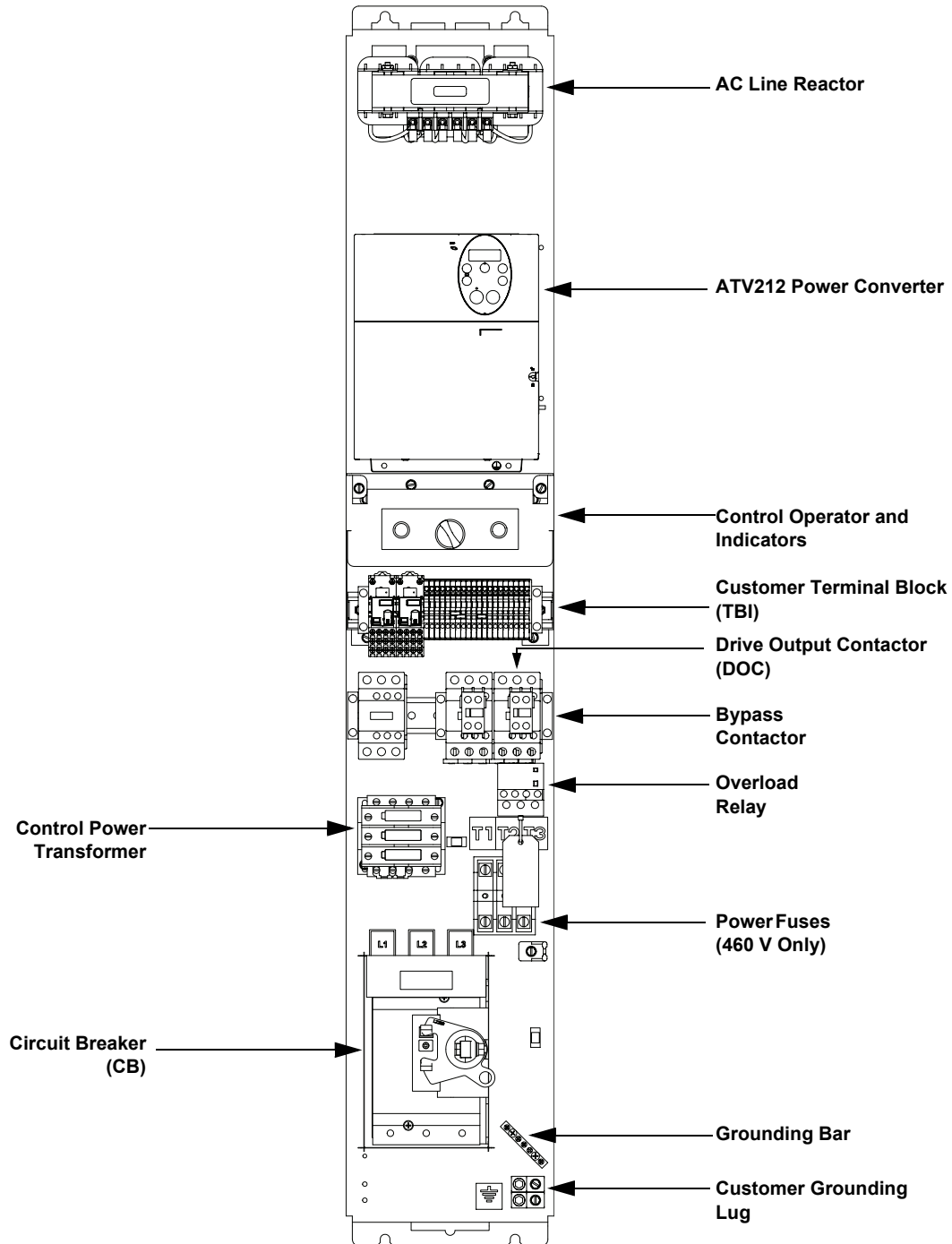
Wiring Methods and Considerations	Noise Class of Conductors <sup>1</sup>				
	QW 1	QW 2	SW 1	SW 2	PW 1
<b>Grounding</b>					
1. Ground shields only at the enclosed drive end.	X	X	X	X	X
2. Use a separate ground wire for each shield ground.	X	X	X	X	X
3. Provide a ground wire with all conductor groups, whether in tray or conduit.			X	X	X
4. When multiple grounds must be made to a shielded power cable, the shield must have the same short circuit withstand capability as the grounding conductor in the power cable.			X	X	X
5. Terminate all power grounds and power shield grounds to the enclosed drive grounding point or power converter chassis.			X	X	X
6. Terminate all signal shield grounds to the terminals provided.	X	X			
7. Always supply a separate equipment grounding conductor with the enclosed drive power feed. Do not depend on metallic conduit for the grounding connection.			X	X	X

<sup>1</sup> "X" indicates applicability to the specified Noise Class.

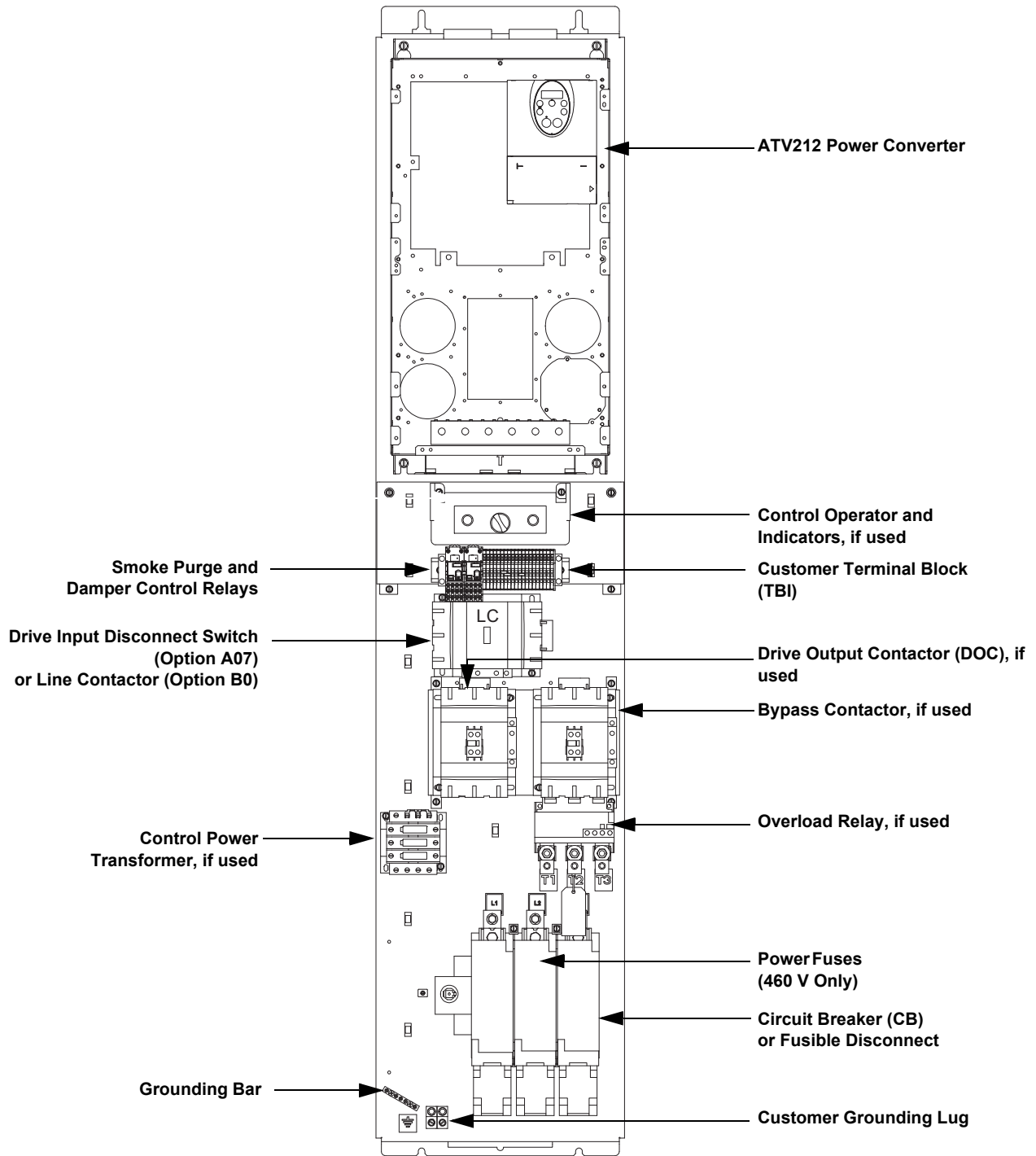
## Component Locations

Figures 33–38 (pages 61–65) show the component identification and terminal strip locations on the S-Flex enclosed drives. Table 10 on page 67 lists the wire size and terminal torque requirements.

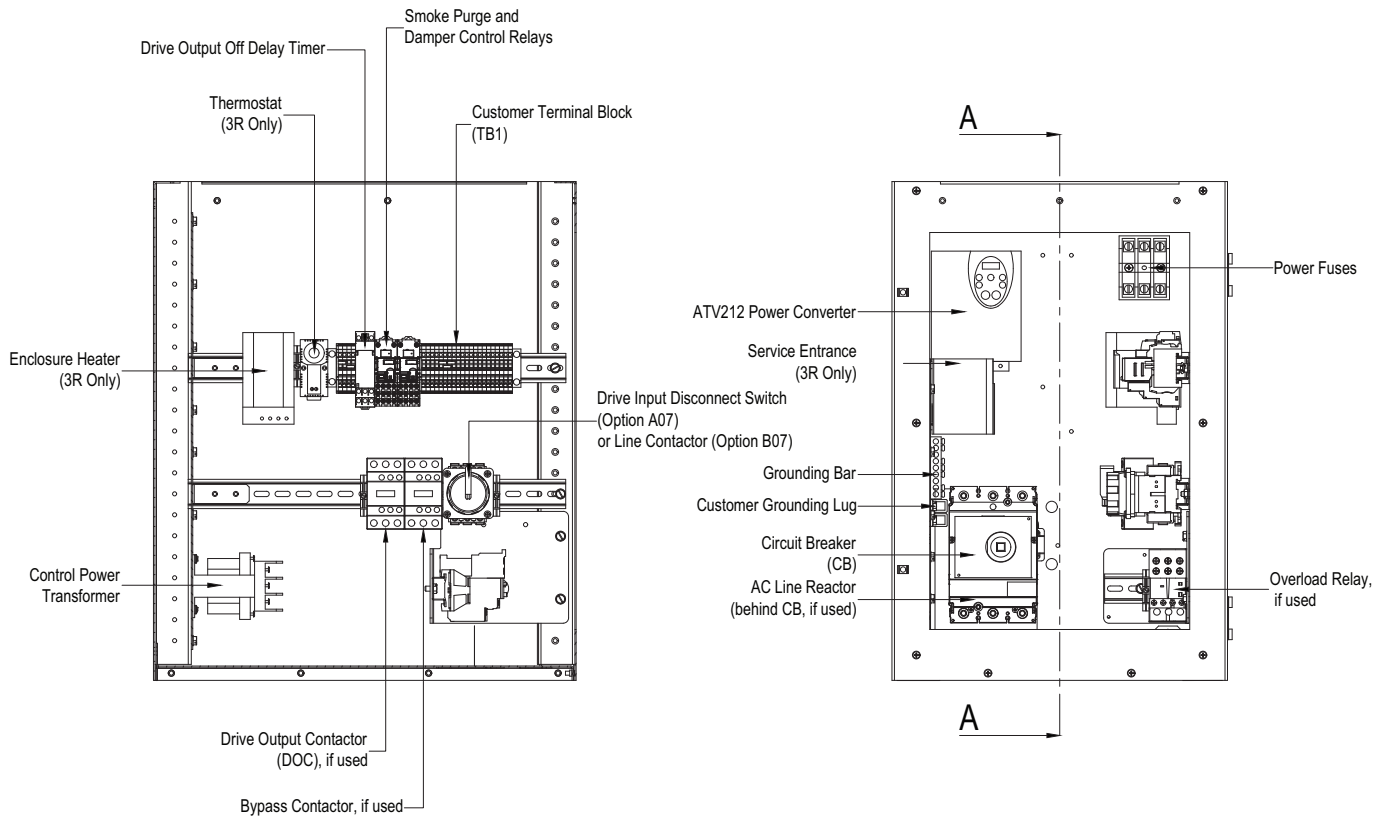
**Figure 33 – Typical Type 1 Component Identification and Terminal Strip Location, (1–30 hp @ 208/230 Vac & 1–60 hp @ 460 Vac with Line Reactor)**



**Figure 34 – Typical Type 1 Component Identification and Terminal Strip Location  
(40 hp @ 208/230 Vac and 75–100 hp @ 460 Vac)**

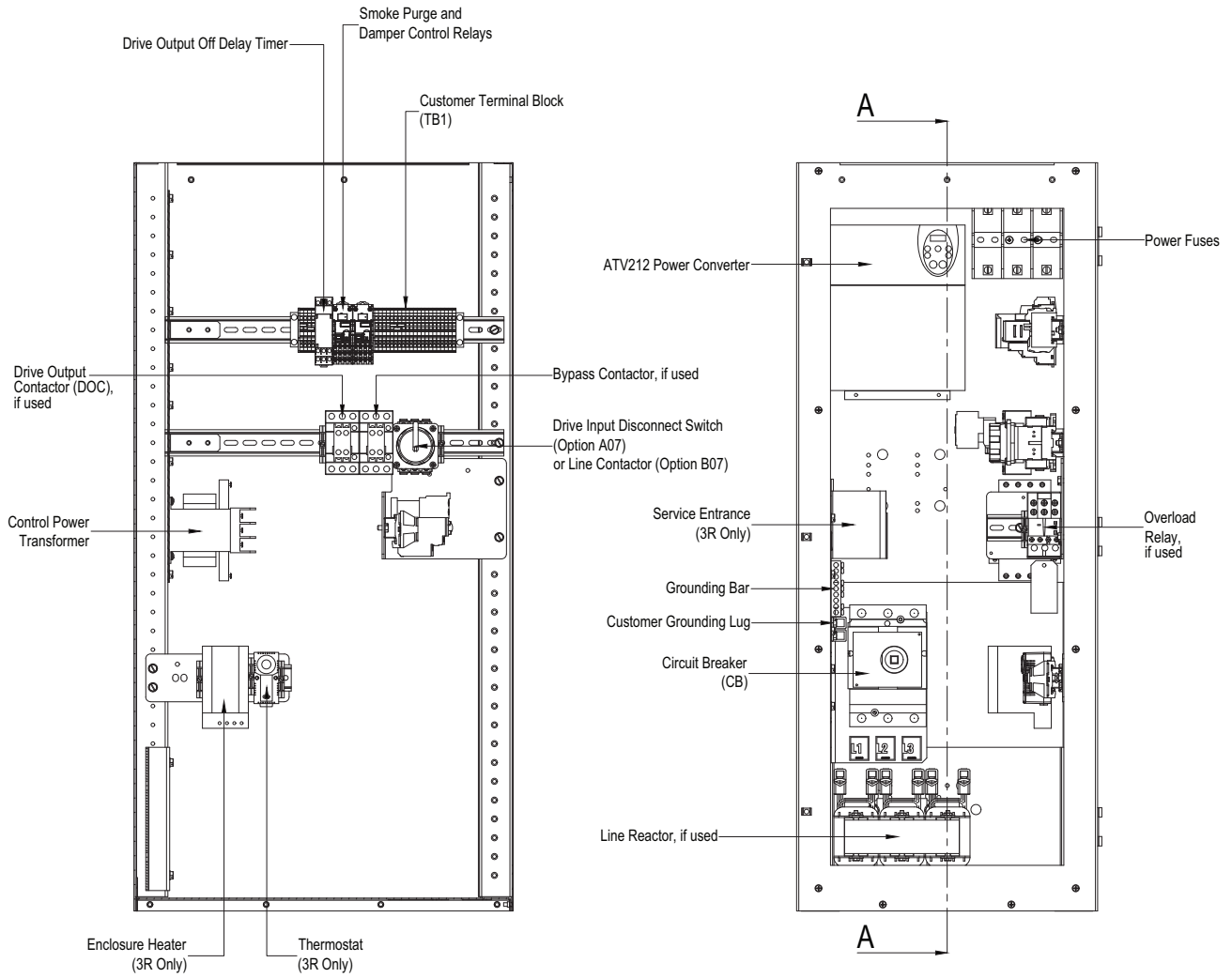


**Figure 35 – Type 12K and 3R Typical Component Identification and Terminal Strip Location  
(1–5 hp @ 208/230 Vac and 1–7.5 hp @ 460 Vac)**



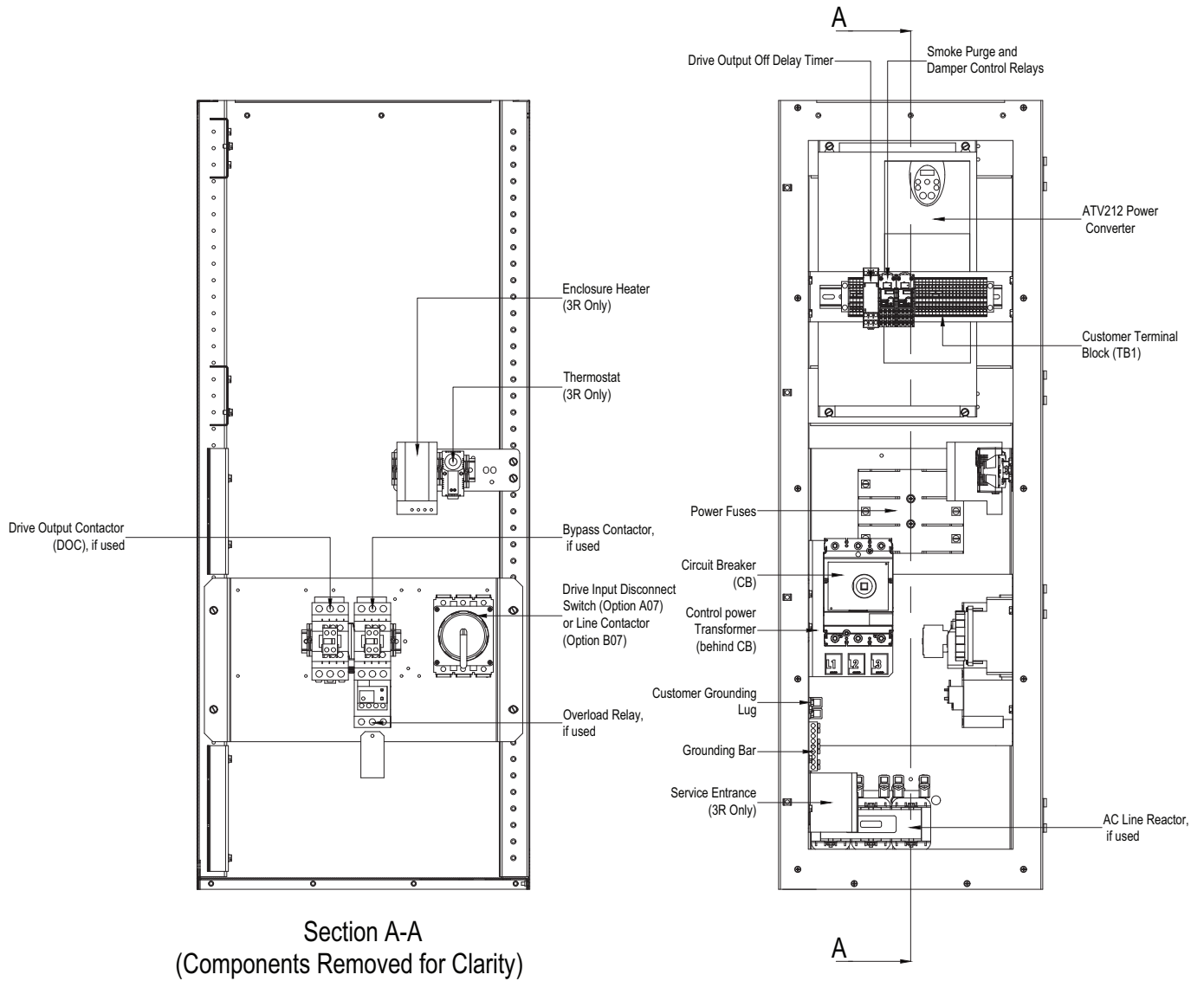
**Section A-A  
(Components Removed for Clarity)**

**Figure 36 – Type 12K and 3R Typical Component Identification and Terminal Strip Location  
(7.5–10 hp @ 208/230 Vac and 10–15 hp @ 460 Vac)**



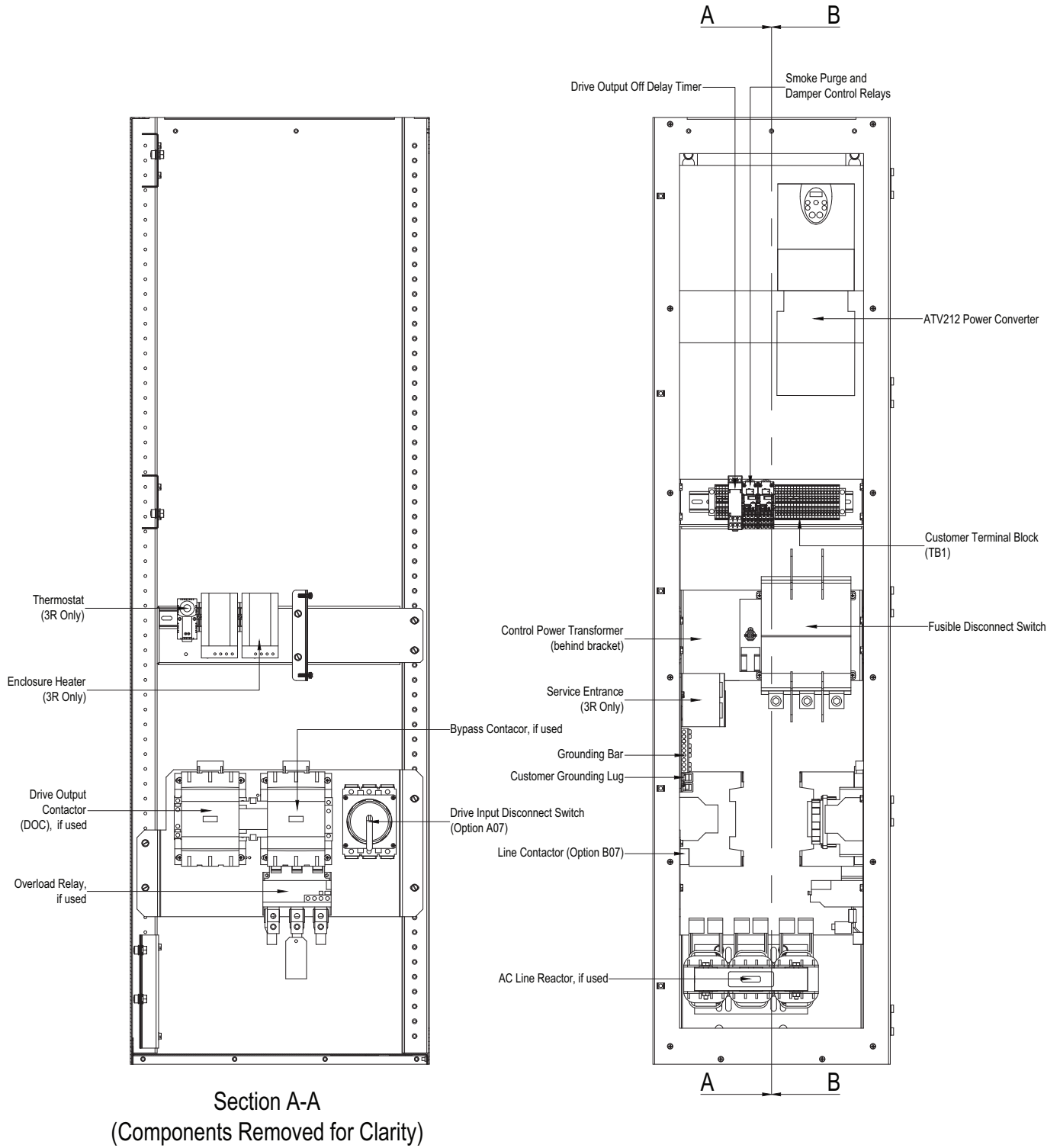
**Section A-A**  
(Components Removed for Clarity)

**Figure 37 – Type 12K and 3R Typical Component Identification and Terminal Strip Location  
(15–30 hp @ 208/230 Vac and 20–40 hp @ 460 Vac)**





**Figure 38 – Type 12K and 3R Typical Component Identification and Terminal Strip Location, (40 hp @ 208/230 Vac and 50–100 hp @ 460 Vac)**



## Power Wiring

### **⚠ DANGER**

#### **HAZARD OF ELECTRIC SHOCK, EXPLOSION, OR ARC FLASH**

- Apply appropriate personal protective equipment (PPE) and follow safe electrical work practices. See NFPA 70E®, CSA Z462, NOM-029-STPS, and other applicable regulations defining safe electrical work practices.
- Some terminals have voltage on them when the disconnect is open.
- Turn off all power supplying this equipment before working on or inside equipment.
- Always use a properly rated voltage sensing device to confirm that power is off.
- Replace covers before turning on power to equipment.
- Refer to “Before You Begin” starting on page 8 for important safety messages and precautions.

**Failure to follow these instructions will result in death or serious injury.**

### **⚠ CAUTION**

#### **IMPROPER WIRING**

- Do not connect input power leads to the enclosed drive output terminals (T1, T2, T3 or U, V, W). This damages the enclosed drive and voids the warranty.
- Check the power connections before energizing the enclosed drive.

**Failure to follow these instructions can result in injury or equipment damage.**

### **⚠ CAUTION**

#### **HEAT AND FIRE DAMAGE**

Follow the torque requirements specified on the S-Flex enclosed drive nameplate.

**Failure to follow these instructions can result in injury or equipment damage.**

**Table 9 – Power Terminal Characteristics**

Terminal	Function	Characteristics <sup>1</sup>
GND	Ground (to grounding lug on panel)	—
L1, L2, L3	Three-phase power supply (to top or bottom of circuit breaker) <sup>2</sup>	208 Vac ±10% (SFD212•2* units) 230 Vac ±10% (SFD212•3* units) 460 Vac ±10% (SFD212•4* units)
T1/U, T2/V, T3/W	Output connections to motor (from overload relay or power converter terminals)	208 Vac ±10% (SFD212•2* units) 230 Vac ±10% (SFD212•3* units) 460 Vac ±10% (SFD212•4* units)

<sup>1</sup> The “•” indicates the enclosure type: “A” = Type 12K, “G” = Type 1, and “H” = Type 3R.  
The “\*” indicates that the catalog number can end in a “Y” (for an S-Flex enclosed drive with full voltage bypass) or a “W” (for an S-Flex enclosed drive without bypass).

<sup>2</sup> Top on G03 (Type 1) or bottom on A03 or H03 (Type 12K or 3R).

**Table 10 – Power Terminal Wire Range and Torque Requirements for FH Mag-Gard™ Circuit Breaker <sup>1</sup>**

SFD212 Type 1 Enclosure	Circuit Breaker L1, L2, L3 (Line)		Overload Relay T1, T2, T3 (Load–Power Circuit Y)		Power Converter U, V, W (Load–Power Circuit W or Motor Grounding Point)		Distribution Block T1, T2, T3 (Load–Power Circuit W)		GND Bar		GND Lug	
	hp	AWG (mm <sup>2</sup> )	lb-in (N•m)	AWG (mm <sup>2</sup> )	lb-in (N•m)	AWG (mm <sup>2</sup> )	lb-in (N•m)	AWG (mm <sup>2</sup> )	lb-in (N•m)	AWG (mm <sup>2</sup> )	lb-in (N•m)	AWG (mm <sup>2</sup> )
1–3 @ 208 V 1–3 @ 230 V 1–7.5 @ 460 V	#14–4 (2.1–21.1)	30 (4.00)	#14–#8 (2.1–8.4)	15 (1.69)	#14–#10 (2.1–6)	11.5 (1.30)	—	—	#14–4 (2.1–21.1)	35 (3.95)	#14–1/0 (2.1–53.4)	100 (11.30)
5 @ 208 V 5 @ 230 V	#14–4 (2.1–21.1)	30 (4.00)	#14–#8 (2.1–8.4)	22.1 (2.50)	#12–#10 (3.3–6)	11.5 (1.30)	—	—	#14–4 (2.1–21.1)	35 (3.95)	#14–1/0 (2.1–53.4)	100 (11.30)
10–15 @ 460 V	#14–4 (2.1–21.1)	30 (4.00)	#14–#8 (2.1–8.4)	22.1 (2.50)	#12–#6 (3.3–13.3)	22 (2.70)	—	—	#14–4 (2.1–21.1)	35 (3.95)	#14–1/0 (2.1–53.4)	100 (11.30)
7.5–10 @ 208 V 7.5–10 @ 230 V	#14–1/0 (2.1–53.4)	80 (9.04)	#14–#8 (2.1–8.4)	22.1 (2.50)	#12–#6 (3.3–13.3)	22 (2.70)	—	—	#14–4 (2.1–21.1)	35 (3.95)	#14–1/0 (2.1–53.4)	100 (11.30)
20 @ 460 V	#14–1/0 (2.1–53.4)	80 (9.04)	#14–#8 (2.1–8.4)	22.1 (2.50)	#8–#3 (8.4–26.7)	40.0 (4.50)	—	—	#14–4 (2.1–21.1)	35 (3.95)	#14–1/0 (2.1–53.4)	100 (11.30)
15–25 @ 208 V 15–25 @ 230 V 25 @ 460 V	#14–1/0 (2.1–53.4)	80 (9.04)	#10–#2 (5.3–33.6)	100 (11.30)	#8–#3 (8.4–26.7)	40.0 (4.50)	—	—	#14–4 (2.1–21.1)	35 (3.95)	#14–1/0 (2.1–53.4)	100 (11.30)
30–60 @ 460 V	#14–1/0 (2.1–53.4)	80 (9.04)	#10–#2 (5.3–33.6)	100 (11.30)	#8–1/0 (8.4–53.4)	212 (24.0)	—	—	#14–4 (2.1–21.1)	35 (3.95)	#14–1/0 (2.1–53.4)	100 (11.30)

<sup>1</sup> See Figures 44 and 45 on pages 84–85 for circuit breaker identification.

**Table 11 – Power Terminal Wire Range and Torque Requirements for PowerPact™ H-Frame Circuit Breaker, 1–60 hp, and GS2 Fusible Switch, 75–100 hp<sup>1</sup>**

SFD212 Type 1 Enclosure	Circuit Breaker L1, L2, L3 (Line)		Overload Relay T1, T2, T3 (Load–Power Circuit Y)		Power Converter U, V, W (Load–Power Circuit W or Motor Grounding Point)		Distribution Block T1, T2, T3 (Load–Power Circuit W)		GND Bar		GND Lug	
	hp	AWG (mm <sup>2</sup> )	lb-in (N•m)	AWG (mm <sup>2</sup> )	lb-in (N•m)	AWG (mm <sup>2</sup> )	lb-in (N•m)	AWG (mm <sup>2</sup> )	lb-in (N•m)	AWG (mm <sup>2</sup> )	lb-in (N•m)	AWG (mm <sup>2</sup> )
1–3 @ 208 V 1–3 @ 230 V 1–7.5 @ 460 V	#14–#10 (2.1–6)	50 (5.65)	#14–#8 (2.1–8.4)	15 (1.69)	#14–#10 (2.1–6)	11.5 (1.30)	—	—	#14–4 (2.1–21.1)	35 (3.95)	#14–1/0 (2.1–53.4)	100 (11.30)
5 @ 208 V 5 @ 230 V	#14–#10 (2.1–6)	50 (5.65)	#14–#8 (2.1–8.4)	22.1 (2.50)	#12–#10 (3.3–6)	11.5 (1.30)	—	—	#14–4 (2.1–21.1)	35 (3.95)	#14–1/0 (2.1–53.4)	100 (11.30)
7.5–10 @ 208 V 7.5–10 @ 230 V 10–15 @ 460 V	#8–1 (8.4–42.4)	120 (13.56)	#14–#8 (2.1–8.4)	22.1 (2.50)	#12–#6 (3.3–13.3)	22 (2.70)	—	—	#14–4 (2.1–21.1)	35 (3.95)	#14–1/0 (2.1–53.4)	100 (11.30)
20 @ 460 V	#8–1 (8.4–42.4)	120 (13.56)	#14–#8 (2.1–8.4)	22.1 (2.50)	#8–#3 (8.4–26.7)	40.0 (4.50)	—	—	#14–4 (2.1–21.1)	35 (3.95)	#14–1/0 (2.1–53.4)	100 (11.30)
15–25 @ 208 V 15–25 @ 230 V 25 @ 460 V	#8–1 (8.4–42.4)	120 (13.56)	#10–#2 (5.3–33.6)	100 (11.30)	#8–#3 (8.4–26.7)	40.0 (4.50)	—	—	#14–4 (2.1–21.1)	35 (3.95)	#14–1/0 (2.1–53.4)	100 (11.30)
30 @ 208 V 30 @ 230 V	#8–1/0 (8.4–53.4)	120 (13.56)	#10–#1 (5.3–42.4)	100 (11.30)	#8–1/0 (8.4–53.4)	212 (24.0)	—	—	#14–4 (2.1–21.1)	35 (3.95)	#14–1/0 (2.1–53.4)	100 (11.30)
30–60 @ 460 V	#8–1/0 (8.4–53.4)	120 (13.56)	#10–#2 (5.3–33.6)	100 (11.30)	#8–1/0 (8.4–53.4)	212 (24.0)	—	—	#14–4 (2.1–21.1)	35 (3.95)	#14–1/0 (2.1–53.4)	100 (11.30)
40 @ 208 V	#8–3/0 (8.4–53.4)	120 (13.56)	#6–3/0 (13.3–85)	160 (18.07)	#3–300 MCM (26.7–150)	212 (24.0)	#10–350 MCM (6–177)	250 (28.3)	#14–4 (2.1–21.1)	35 (3.95)	#14–1/0 (2.1–53.4)	100 (11.30)
40 @ 230 V	#8–3/0 (8.4–53.4)	120 (13.56)	#10–#1 (5.3–42.4)	100 (11.30)	#3–300 MCM (26.7–150)	212 (24.0)	#10–350 MCM (6–177)	250 (28.3)	#14–4 (2.1–21.1)	35 (3.95)	#14–1/0 (2.1–53.4)	100 (11.30)
75 @ 460 V	#6–3/0 (13.3–85)	275 (31.1)	#10–#1 (5.3–42.4)	100 (11.30)	#3–300 MCM (26.7–150)	363 (41.0)	#10–350 MCM (6–177)	250 (28.3)	#14–4 (2.1–21.1)	35 (3.95)	#14–1/0 (2.1–53.4)	100 (11.30)
100 @ 460 V	#6–3/0 (13.3–85)	275 (31.1)	#6–3/0 (13.3–85)	160 (18.07)	#3–300 MCM (26.7–150)	363 (41.0)	#10–350 MCM (6–177)	250 (28.3)	#14–4 (2.1–21.1)	35 (3.95)	#14–1/0 (2.1–53.4)	100 (11.30)

<sup>1</sup> See Figures 44 and 45 on pages 84–85 for circuit breaker identification.

**Table 12 – Power Terminal Wire Range and Torque Requirements for PowerPact™ H-Frame Circuit Breaker<sup>1</sup> 1–60 hp and GS2 Fusible Switch 50–100 hp**

SFD212 Type 12K/3R Enclosures	Circuit Breaker L1, L2, L3 (Line)		Overload Relay T1, T2, T3 (Load–Power Circuit Y)		Power Converter U, V, W (Load–Power Circuit W or Motor Grounding Point)		Distribution Block T1, T2, T3 (Load–Power Circuit W)		GND Bar		GND Lug	
	hp	AWG (mm <sup>2</sup> )	lb-in (N•m)	AWG (mm <sup>2</sup> )	lb-in (N•m)	AWG (mm <sup>2</sup> )	lb-in (N•m)	AWG (mm <sup>2</sup> )	lb-in (N•m)	AWG (mm <sup>2</sup> )	lb-in (N•m)	AWG (mm <sup>2</sup> )
1–3 @ 208 V 1–3 @ 230 V 1–7.5 @ 460 V	#14–#10 (2.1–6)	50 (5.65)	#14–#8 (2.1–8.4)	15 (1.69)	#14–#10 (2.1–6)	11.5 (1.30)	—	—	#14–4 (2.1–21.1)	35 (3.95)	#14–1/0 (2.1–53.4)	100 (11.30)
5 @ 208 V 5 @ 230 V	#14–#10 (2.1–6)	50 (5.65)	#14–#8 (2.1–8.4)	22.1 (2.5)	#12–#10 (3.3–6)	11.5 (1.30)	—	—	#14–4 (2.1–21.1)	35 (3.95)	#14–1/0 (2.1–53.4)	100 (11.30)
7.5–10 @ 208 V 7.5–10 @ 230 V 10–15 @ 460 V	#8–#1 (8.4–42.4)	120 (13.56)	#14–#8 (2.1–8.4)	22.1 (2.5)	#12–#6 (3.3–13.3)	22 (2.70)	—	—	#14–4 (2.1–21.1)	35 (3.95)	#14–1/0 (2.1–53.4)	100 (11.30)
20 @ 460 V	#8–#1 (8.4–42.4)	120 (13.56)	#14–#8 (2.1–8.4)	22.1 (2.5)	#8–#3 (8.4–26.7)	40 (4.50)	—	—	#14–4 (2.1–21.1)	35 (3.95)	#14–1/0 (2.1–53.4)	100 (11.30)
15–25 @ 208 V 15–25 @ 230 V 25 @ 460 V	#8–#1 (8.4–42.4)	120 (13.56)	#10–#2 (5.3–33.6)	100 (11.3)	#8–#3 (8.4–26.7)	40 (4.50)	—	—	#14–4 (2.1–21.1)	35 (3.95)	#14–1/0 (2.1–53.4)	100 (11.30)
30 @ 208 V 30 @ 230 V	#8–1/0 (8.4–53.4)	120 (13.56)	#10–#1 (5.3–42.4)	100 (11.3)	#8–1/0 (8.4–53.4)	212 (24.0)	—	—	#14–4 (2.1–21.1)	35 (3.95)	#14–1/0 (2.1–53.4)	100 (11.30)
30–40 @ 460 V	#8–1/0 (8.4–53.4)	120 (13.56)	#10–#2 (5.3–33.6)	100 (11.3)	#8–1/0 (8.4–53.4)	212 (24.0)	—	—	#14–4 (2.1–21.1)	35 (3.95)	#14–1/0 (2.1–53.4)	100 (11.30)
40 @ 208 V	#8–3/0 (8.4–53.4)	120 (13.56)	#6–#3/0 (13.3–85)	160 (18.07)	#3–300 MCM (26.7–150)	212 (24.0)	—	—	#14–4 (2.1–21.1)	35 (3.95)	#14–1/0 (2.1–53.4)	100 (11.30)
40 @ 230 V	#8–3/0 (8.4–53.4)	120 (13.56)	#10–#1 (5.3–42.4)	100 (11.3)	#3–300 MCM (26.7–150)	212 (24.0)	—	—	#14–4 (2.1–21.1)	35 (3.95)	#14–1/0 (2.1–53.4)	100 (11.30)
50 @ 460 V	#6–3/0 (13.3–85)	275 (31.1)	#10–#2 (5.3–33.6)	100 (11.3)	#8–1/0 (8.4–53.4)	212 (24.0)	—	—	#14–4 (2.1–21.1)	35 (3.95)	#14–1/0 (2.1–53.4)	100 (11.30)
60 @ 460 V	#6–3/0 (13.3–85)	275 (31.1)	#10–#2 (5.3–33.6)	100 (11.3)	#8–1/0 (8.4–53.4)	212 (24.0)	—	—	#14–4 (2.1–21.1)	35 (3.95)	#14–1/0 (2.1–53.4)	100 (11.30)
75 @ 460 V	#6–3/0 (13.3–85)	275 (31.1)	#10–#1 (5.3–42.4)	100 (11.3)	#3–300 MCM (26.7–150)	363 (41.0)	—	—	#14–4 (2.1–21.1)	35 (3.95)	#14–1/0 (2.1–53.4)	100 (11.30)
100 @ 460 V	#6–3/0 (13.3–85)	275 (31.1)	#6–3/0 (13.3–85)	160 (18.07)	#3–300 MCM (26.7–150)	363 (41.0)	—	—	#14–4 (2.1–21.1)	35 (3.95)	#14–1/0 (2.1–53.4)	100 (11.30)

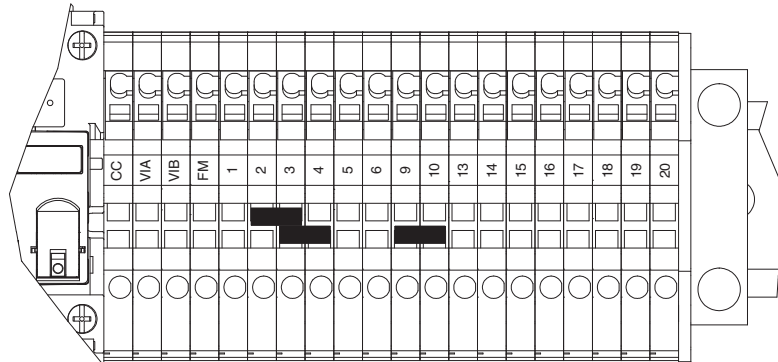
<sup>1</sup> See Figures 44 and 45 on pages 84–85 for circuit breaker identification.

## Control Wiring

Connect the control wiring to the bottom portion of the terminal block TB1. See Figure 39.

Each terminal is rated for one wire, 24–16 AWG (0.25–1.5 mm<sup>2</sup>). Torque the terminal screws to 5.3–7.1 lb-in (0.6–0.8 N•m). The customer terminals are designated on the wiring diagrams in this instruction bulletin. See “Wiring Diagrams” on page 96.

**Figure 39 – Bypass Power Circuit Y, Series D<sup>1</sup>**



<sup>1</sup> To identify the series, refer to the nameplate on the enclosed drive.

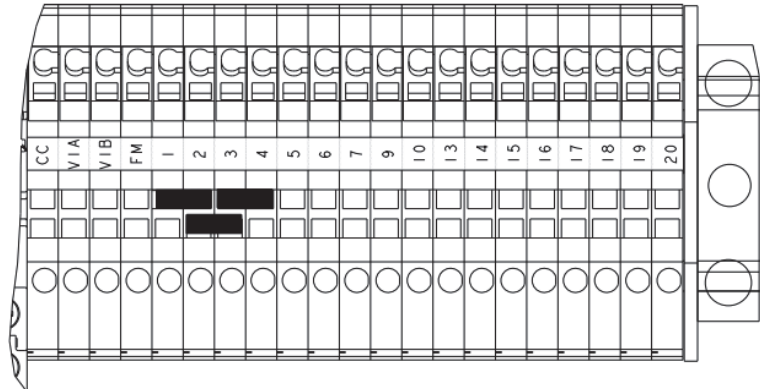
**Table 13 – TB1 Customer Terminal Connections, Series D**

Function	Description	Customer Terminals (See Figure 39)	
0–10 Vdc Input	AFC Speed Reference	VIB	CC
4–20 mA or 0–10 Vdc Input <sup>1, 2</sup>	AFC Speed Reference	VIA	CC
Analog Output Signal <sup>1</sup>	Configurable	FM	CC
Smoke Purge Relay Disable	Add Jumper	1	2
Freeze/Firestat	Remove Jumper / Add Interlock	2	3
Damper End Switch Enable	Remove Jumper	3	4
Auto Start Contact	AFC Mode Run Input	5	6
Smoke Purge Relay Disable	Remove Jumper	9	10
System Run Auxiliary Contact <sup>1</sup>	Closes on Motor Running (AFC or BYP)	13	14
AFC Trip Auxiliary Contact	Closes on AFC Trip	15	16
Smoke Purge Relay Coil	120 Vac to Energize Coil	17	18
Open Damper Signal	Closes when Run Signal Provided	19	20

<sup>1</sup> When option B06 (LonWorks) is selected, the drive run contact and analog output are not provided. Both functions can be monitored via LonWorks communications.

<sup>2</sup> Factory set for current control. To change input VIA to voltage control, see *Altivar 212 Programming and Operation Guide*, S1A53838.

**Figure 40 – Bypass Power Circuit Y, Series E<sup>1</sup>**



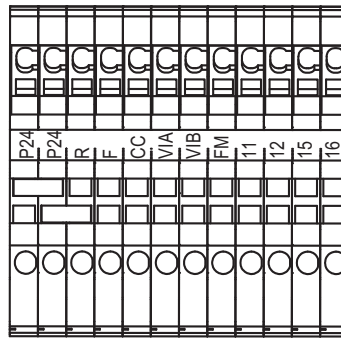
<sup>1</sup> To identify the series, refer to the nameplate on the enclosed drive.

**Table 14 – Customer Terminal Connections, Series E**

Functions	Descriptions	Customer Terminals (See Figure 40)	
0–10 Vdc Input	AFC Speed Reference	V1B	CC
4–20 mA or 0–10 Vdc Input <sup>1, 2</sup>	AFC Speed Reference	V1A	CC
Analog Output Signal <sup>2</sup>	Configurable	FM	CC
Freeze/Firestat	Remove Jumper / Add Interlock	1	2
End Damper Switch	Remove Jumper / Add Interlock	2	3
Smoke Purge Relay Enable	Remove Jumper to Enable	3	4
Auto Start Contact	AFC Model Run Input	5	6
Smoke Purge Relay Enable	Install Jumper to Enable	9	10
System Run Auxiliary Contact <sup>2</sup>	Closes on Motor Running (AFC or BYP)	13	14
AFC Trip Auxiliary Contact	Closes on AFC Trip	15	16
Smoke Purge Relay Coil	120 Vac to Energize Coil	17	18
Open Damper Signal	Closes when Run Signal is Provided	19	20

<sup>1</sup> Factory set for current control. To change input VIA to voltage control, see *Altivar 212 Programming and Operation Guide*, S1A53838.

<sup>2</sup> When option B06 (LonWorks) is selected, the drive run contact and analog output are not provided. Both functions can be monitored via LonWorks communications.

**Figure 41 – Non-Bypass Power Circuit W****Table 15 – TB1 Customer Terminal Connections for Enclosed Drives Without Bypass**

Function	Description	Customer Terminals (See Figure 41)	
Auto Start Contact	AFC Mode Run Input	P24	F
Freeze/Firestat	Remove Jumper / Add Interlock	P24	R
0–10 Vdc Input	AFC Speed Reference	VIB	CC
4–20 mA or 0–10 Vdc Input <sup>1,2</sup>	AFC Speed Reference	VIA	CC
Analog Output Signal <sup>2</sup>	Configurable	FM	CC
AFC Run Auxiliary Contact <sup>2</sup>	Closes with AFC Running Motor	11	12
AFC Detected Fault Auxiliary Contact	Closes on AFC Detected Fault	15	16

<sup>1</sup> Factory set for current control.

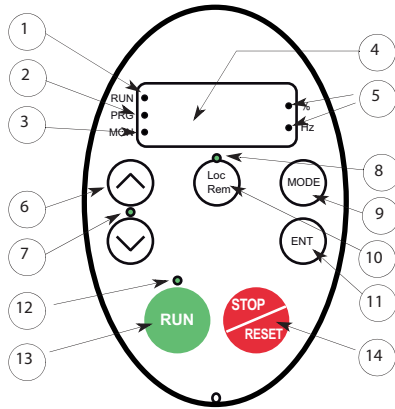
To change the input VIA to voltage control, see *Altivar 212 Programming and Operation Guide*, S1A53838.

<sup>2</sup> When option B06 (LonWorks) is selected, the drive run contact and analog output are not provided. Both functions can be monitored via LonWorks communications.



# Keypad Operation

## Integrated Keypad



**Table 16 – Integrated Keypad Features <sup>1</sup>**

	LED/Key	Characteristics
1	Display RUN LED	Illuminates when a run command is applied to the drive. Flashes when there is a speed reference present with a Run command.
2	Display PRG LED	Illuminates when Programming mode is active. Flashes when programming parameters within menus (for example <i>A U H</i> , <i>A U F</i> , <i>G r U</i> , <i>I D</i> , or <i>C O N</i> ).
3	Display MON LED	Illuminates when Monitoring mode is active. Flashes in trip history display mode.
4	Display unit	4 digits, 7 segments
5	Display unit LED	The % LED illuminates when a displayed numeric value is a percentage. The Hz LED illuminates when a displayed numeric value is in hertz.
6	UP/DOWN keys	Depending on the mode, you can use the arrows to: <ul style="list-style-type: none"> <li>• Navigate between the menus</li> <li>• Change a value</li> <li>• Change the speed reference when the UP/DOWN LED (7) is illuminated.</li> </ul>
7	UP/DOWN LED	Illuminates when the navigation arrows are controlling the speed reference.
8	Loc/Rem LED	Illuminates when Local mode is selected.
9	MODE	Press to select the embedded keypad mode. <ul style="list-style-type: none"> <li>• Run mode (default on power-up)</li> <li>• Programming mode</li> <li>• Monitoring mode</li> </ul> Can also be used to go back to the previous menu.
10	Loc/Rem	Switches between Local and Remote modes.
11	ENT	Press to display a parameter's value or to save a changed value.
12	RUN LED	Illuminates when the Run key is enabled.

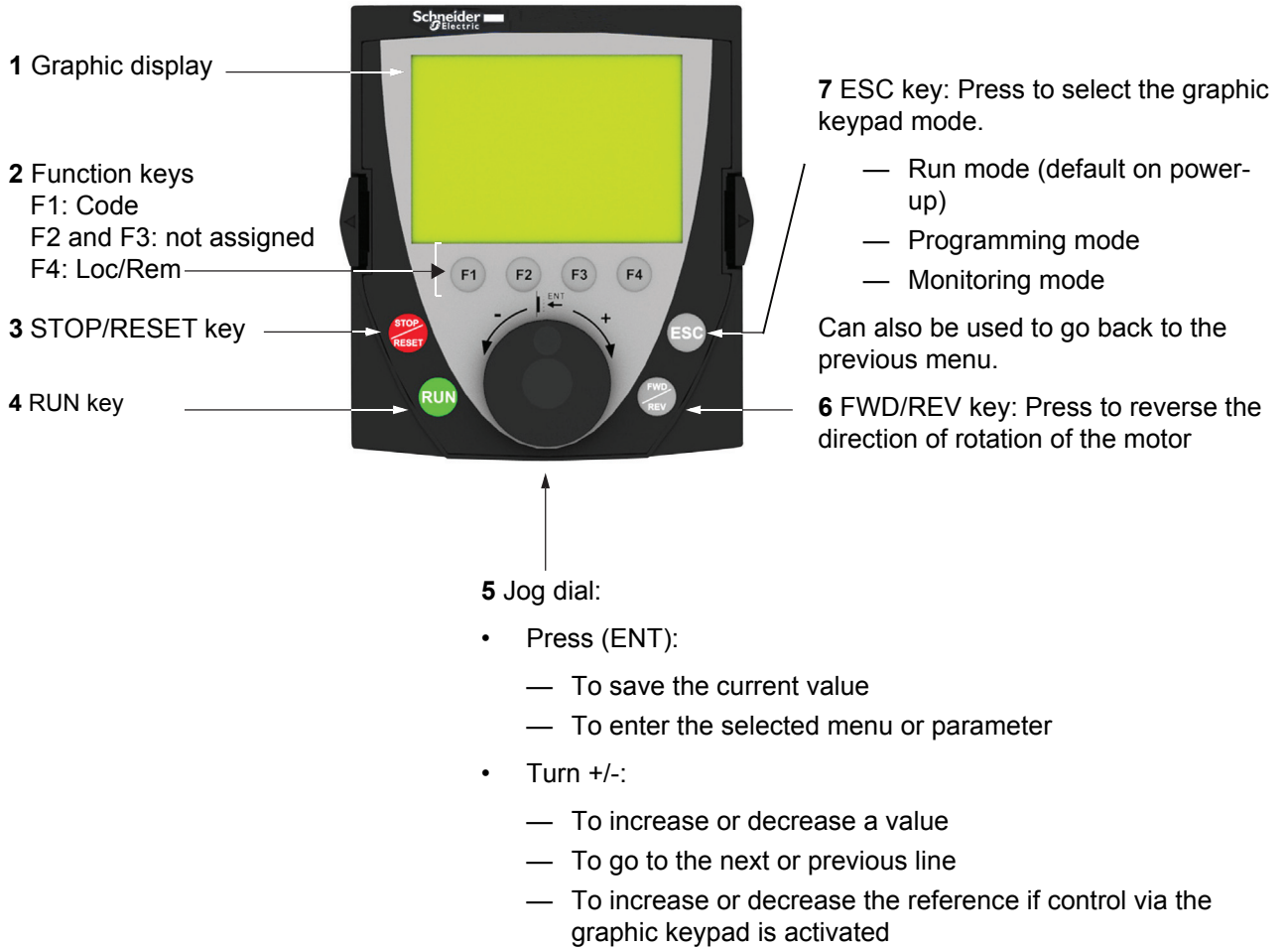
**Table 16 – Integrated Keypad Features <sup>1</sup>** *(continued)*

	LED/Key	Characteristics
13	RUN	Pressing this key when the RUN LED is illuminated starts the drive.
14	STOP	<p>Stop/reset key.</p> <p>In Local mode, pressing the STOP key causes the drive to stop based on the setting of parameter [Loc. mot stop mode] (<i>F 7 2 1</i>).</p> <p>In Remote mode, pressing the STOP key causes the drive to stop based on the setting of parameter [Ext. fault stop Mode] (<i>F 5 0 3</i>). The display will indicate a flashing “E”. To reset the drive, cycle the power.</p> <p>If [HMI reset button] (<i>F 7 3 5</i>) is set to 0 (default setting), pressing the STOP key twice will reset all the resettable detected faults if the trip condition has been resolved.</p>

<sup>1</sup> An optional graphic keypad is also available by selecting option D07. See page 75.

### Graphic Keypad Option (D07)

The graphic keypad, with FLASH V1.1IE26 or higher, displays more detailed information than can be shown on the integrated keypad.



**NOTE:** Keys **3**, **4**, **5** and **6** can be used to control the drive directly, if control via the graphic keypad is activated.

## Programming Access with Type 3R Enclosure

### **⚠ DANGER**

#### **HAZARD OF ELECTRIC SHOCK, EXPLOSION, OR ARC FLASH**

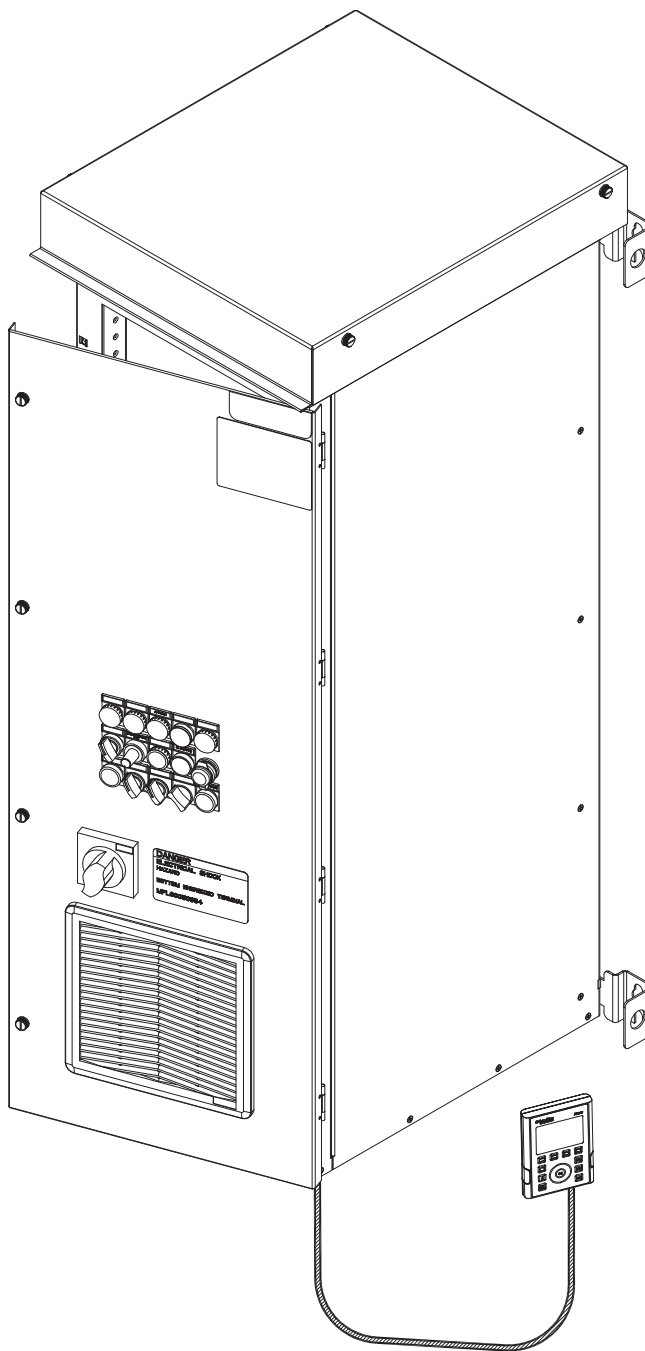
- Apply appropriate personal protective equipment (PPE) and follow safe electrical work practices. See NFPA 70E®, CSA Z462, NOM-029-STPS, and other applicable regulations defining safe electrical work practices.
- This equipment must only be installed and serviced by qualified electrical personnel.
- Turn off all power supplying this equipment before working on or inside equipment.
- Always use a properly rated voltage sensing device to confirm power is off.
- Replace all devices, doors, and covers before turning on power to this equipment.

**Failure to follow these instructions will result in death or serious injury.**

Type 3R enclosures come with a remote keypad and cable inside the enclosure. To program the process drive with this equipment:

1. Remove all power from the enclosed drive.
2. Turn the circuit breaker and handle assembly to the Off position and open the enclosure door.
3. Test for the absence of voltage.  
**NOTE:** Verify that the voltage tester is functioning properly before and after testing for the absence of voltage.
4. Remove the remote keypad and cable from the enclosure.
5. Connect the remote keypad and cable to the drive.
6. Route the keypad cable between the bottom enclosure flange and the bottom of the door flange. See Figure 42 on page 77.
7. Close and secure the enclosure door. Ensure that the keypad cable is not pinched by the door.
8. Close the disconnect means.
9. Program the drive with the keypad.
10. When programming is complete, remove all power then test for the absence of voltage.
11. Open the enclosure door and remove the remote keypad cable from the drive.
12. Place the remote keypad and cable inside the enclosure. Do not leave the remote keypad in the bottom of the enclosure.
13. Close and secure the enclosure door.

**Figure 42 – Routing the Remote Keypad on Wall Mounted Enclosures**



## Initial Start-up Procedure

### **⚠ DANGER**

#### **HAZARD OF ELECTRIC SHOCK, EXPLOSION, OR ARC FLASH**

- Read and understand this manual before installing or operating the S-Flex enclosed drive. Installation, adjustment, repair, and maintenance must be performed by qualified personnel.
- The user is responsible for compliance with all national and local electrical code requirements with respect to grounding of all equipment.
- Many parts of this enclosed drive, including the printed circuit boards, operate at the line voltage. **DO NOT TOUCH.** Use only electrically insulated tools.
- Some terminals have voltage on them when the disconnect is open.
- **DO NOT** short across terminals PA/+ and PC/- or across the DC bus capacitors.
- Before servicing the enclosed drive:
  - Disconnect all power including external control power that may be present.
  - Place a “DO NOT TURN ON” label on all power disconnects.
  - Lock all power disconnects in the open position.
  - **WAIT 15 MINUTES** to allow the DC bus capacitors to discharge. Then follow the DC Bus Voltage Measurement Procedure on page 56 to verify that the DC voltage is less than 42 V. The drive LED is not an indicator of the absence of DC bus voltage.
- Install and close all covers and doors before applying power or starting and stopping the enclosed drive.

**Failure to follow these instructions will result in death or serious injury.**

### **⚠ DANGER**

#### **UNQUALIFIED PERSONNEL**

- This equipment must be installed and serviced only by qualified personnel.
- Qualified personnel performing diagnostics or troubleshooting requiring electrical conductors to be energized must comply with NFPA 70E®, CSA Z462, NOM-029-STPS, and other applicable regulations defining safe electrical work practices.

**Failure to follow these instructions will result in death or serious injury.**

**⚠ DANGER****HAZARD OF ELECTRIC SHOCK, EXPLOSION, OR ARC FLASH**

- Before applying power, properly ground the enclosed drive panel and close and secure the enclosure door.
- Certain adjustments and test procedures require that power be applied to this enclosed drive. Exercise extreme caution as hazardous voltages exist.
- The enclosure door must be closed and secured while turning on power or starting and stopping this enclosed drive. Always follow the practices and procedures from NFPA 70E, “Standard for Electrical Safety in the Workplace®.”

**Failure to follow these instructions will result in death or serious injury.**

The S-Flex enclosed drive has been configured for the installed options and tested at the factory. Minor adjustments to complete the field installation may be required based upon the application requirements. Using the door-mounted or remote-mounted graphic display terminal or the optional SoMove™ software, follow this start-up procedure step by step. In case of difficulty, refer to “Maintenance and Support” beginning on page 112.

### Checking the Enclosure Components and Connections

With all incoming power removed, make the following equipment checks:

1. Verify that all equipment disconnects are open.
2. For units with full voltage bypass, set the AFC-Off-Bypass (or Hand-Off-Auto) selector switch to the Off position.

**⚠ WARNING****UNINTENDED CONFIGURATION CHANGES**

- Changing the macro configurations or installing a new option card reconfigures the drive to factory settings.
- The configuration must be reinstalled.

**Failure to follow these instructions can result in death or serious injury.**

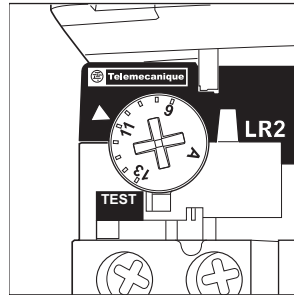
3. Wait 15 minutes, then perform the “DC Bus Voltage Measurement Procedure” beginning on page 56.
4. Open the enclosure door. To open the door, turn the handle assembly to the Off position.
5. Check the wiring of the input power ground and the motor ground.
6. Ensure that the motor conductors are wired to the T1, T2, and T3 terminals of the overload relay.

**NOTE:** When using the bypass circuit, ensure that the motor conductors are wired to the T1, T2, and T3 terminals of the overload relay. When using the power circuit without bypass, ensure that the motor conductors are wired to T1/U, T2/V, and T3/W of the drive or T1, T2, and T3 of the distribution block.

## Adjusting Bypass Motor Overload Protection

7. If the enclosed drive includes a bypass option for running the motor across the line, set the overload relay dial (on the load side of the bypass contactor) to the full load ampere rating (FLA) listed on the nameplate of the connected motor. See Figure 43.

**Figure 43 – Overload Relay Dial**



**NOTE:** The LR2D1516 overload relay is shown. Your dial setting range may be different. Refer to Table 17 on page 86 for range of adjustment.

8. Using a voltmeter set at the 1000 Vac scale, verify that the incoming line voltage at the line side of the disconnecting means is within  $\pm 10\%$  of the input voltage rating on the enclosed drive nameplate.
9. When supplied with a drive input disconnect switch, confirm that the switch is in the On position.
10. Close and secure the enclosure door. Close the equipment disconnect means. The Power On pilot light illuminates (if used for Bypass Power Circuit Y).

### ⚠ CAUTION

#### OVERHEATED MOTOR

- This drive does not provide direct thermal protection for the motor.
- Use of a thermal sensor in the motor may be required for protection at all speeds or load conditions.
- Consult the motor manufacturer for the thermal capability of the motor when it is operated above the desired speed range.

**Failure to follow these instructions can result in injury or equipment damage.**

11. Adjust the full load current setting as follows:

#### Programming by 7-Segment LED

- Press the MODE key on the integrated display terminal until the PRG LED is illuminated and the display shows AUF. Press the ENT key once, then press the DOWN arrow key until tHr is displayed.
- Press the ENT key, then use the UP and DOWN arrow keys to adjust the setting to match the full load current listed on the motor nameplate.
- Press the ENT key to save the setting, and press the MODE key three times to return to the original menu.



Programming by Graphic Keypad

- Press the ESC key until the PROGRAMMING MENU is displayed, turn the Jog dial until QUICK MENU (AUF) is highlighted. Press the Jog dial once, then turn the Jog dial until MOTOR THERMAL PROT. (tHr) is highlighted.
- Press the Jog dial once to adjust the setting to match the full load current on the motor nameplate.
- Press the Jog dial once to save the setting. Press the ESC key to exit to the PROGRAMMING MENU.

**NOTE:** The settings listed in this procedure are suitable for most applications. If your application requires different operating characteristics, refer to the *Altivar 212 Programming and Operation Guide*, S1A53838, for more information.

<b>⚠ WARNING</b>
<p><b>HAZARDOUS MOVING PARTS</b></p> <p>Before starting the enclosed drive, ensure that personnel are clear of the motor and its connected load and that the motor and load are ready to run.</p> <p><b>Failure to follow these instructions can result in death or serious injury.</b></p>

**Checking and Correcting Motor Rotation**

12. Power circuit W or Y, Series D: Set the AFC-Off-Bypass selector switch (if used) to AFC. Check the direction of motor rotation.
  - If correct, proceed to Step 17 on page 82.
  - If incorrect, turn the AFC-Off-Bypass selector switch back to Off or press STOP on the power converter control keypad.

Power circuit Y, Series E: Set the AFC-Bypass selector switch to AFC. Set the Hand-Off-Auto (HOA) selector switch to Hand. Check the direction of motor rotation then set the HOA switch back to Off. If rotation is correct, proceed to Step 17.

<b>⚠ DANGER</b>
<p><b>HAZARD OF ELECTRIC SHOCK, EXPLOSION, OR ARC FLASH</b></p> <ul style="list-style-type: none"> <li>• Turn off all power supplying this equipment.</li> <li>• Wait 15 minutes.</li> <li>• Perform the “DC Bus Voltage Measurement Procedure” beginning on page 56 before proceeding.</li> </ul> <p><b>Failure to follow these instructions will result in death or serious injury.</b></p>

13. Correct the direction of motor rotation by reversing any two motor leads connected to the enclosed drive output (see Step 6, page 79).
14. Close and secure the enclosure door. Close the equipment disconnect means. The Power On pilot light illuminates.
15. Power circuit W or Y, Series D: Set the AFC-Off-Bypass selector switch (if used) to AFC. Check the direction of motor rotation. If correct, this completes the drive mode, motor rotation check. Turn the AFC-Off-Bypass selector switch back to Off or press STOP on the power converter control keypad. For Non-Bypass Power Circuit W, skip to Step 20 on page 83.

Power circuit Y, Series E: Set the AFC-Bypass selector switch to AFC. Set the Hand-Off-Auto (HOA) selector switch to Hand. Check the direction of motor rotation then set the HOA switch back to Off. If the rotation is correct, this completes the drive mode, motor rotation check. For Non-Bypass Power Circuit W, skip to Step 20.

### Checking and Correcting Motor Rotation in Bypass Mode

16. Power circuit W or Y, Series D: Momentarily set the AFC-Off-Bypass selector switch to Bypass to check the direction of motor rotation, then return it immediately to the Off position.

- If the direction of motor rotation is correct, proceed to Step 20.
- If the direction of motor rotation is incorrect, stop the enclosed drive.

**Remove all power!**

Power circuit Y, Series E: Set the AFC-Bypass selector switch to Bypass. Set the HOA switch to Hand. Check the direction of motor rotation then set the HOA switch back to Off. If the direction of motor rotation is correct, proceed to Step 20. If incorrect, stop the enclosed drive. **Remove all power!**

**NOTE:** If the enclosed drive circuit breaker trips during this test, a higher trip setting may be required. Refer to “Adjusting Mag-Gard or PowerPact Magnetic Trip Setting” on page 84.

## ⚠ DANGER

### HAZARD OF ELECTRIC SHOCK, EXPLOSION, OR ARC FLASH

- Turn off all power supplying this equipment.
- Wait 15 minutes.
- Perform the “DC Bus Voltage Measurement Procedure” beginning on page 56 before proceeding.

**Failure to follow these instructions will result in death or serious injury.**

17. Correct the direction of motor rotation by reversing any two incoming leads to the circuit breaker disconnect means marked L1, L2, or L3.

18. Power circuit Y, Series D: Momentarily set the AFC-Off-Bypass selector switch to Bypass to check the direction of motor rotation, then return it immediately to the Off position. If correct, this completes the bypass mode motor rotation check.

Power circuit Y, Series E: Set the AFC-Bypass selector switch to Bypass. Set the HOA switch to Hand. Check the direction of motor rotation then set the HOA switch back to Off. If the direction of motor rotation is correct, this completes the bypass mode motor rotation check.

### Checking the Graphic Terminal Settings

19. Adjust the High Speed (UL) Setting as follows:

Programming by 7-Segment LED

Check the High Speed (UL) setting (maximum motor speed). Press the MODE key until AUF is displayed. Using the UP and DOWN arrow keys, scroll to UL, then press the ENT key. Use the UP and DOWN arrow keys to adjust the maximum output frequency for the required application (factory default is 60 Hz), then press the ENT key. The enclosed drive UL setting is now complete.

#### Programming by Graphic Keypad

Check the High Speed (UL) setting (maximum motor speed.) Press the ESC key until PROGRAMMING MENU is displayed and turn the dial until QUICK MENU (AUF) is highlighted, then press the Jog dial. Turn the Jog dial until UPPER LIMIT FREQ (UL) is highlighted, then press the Jog dial. Turn the Jog dial to adjust the maximum output frequency for the required application (factory default is 60 Hz), then press the Jog dial once to save the setting.

Refer to the *Altivar 212 Programming and Operation Guide*, S1A53838.

#### 20. Adjust the Low Speed (LL) Setting as follows:

##### Programming by 7-Segment LED

Check the Low Speed (LL) setting (minimum motor speed). Continuing from Step 19 above, using the UP and DOWN arrow keys, scroll to LL, then press the ENT key. Use the UP and DOWN arrows keys to adjust the minimum output frequency for the required application (preset value is 15 Hz; factory default is 0 Hz), then press the ENT key. The enclosed drive LL setting is now complete. Press the MODE key three times to return to the original menu.

##### Programming by Graphic Keypad

Check the Low Speed (LL) setting (minimum motor speed). Continuing from Step 19 above, turn the Jog dial until LOW LIMIT FREQUENCY (LL) is highlighted, then press the Jog dial. Turn the Jog dial to adjust the minimum output frequency for the required application (preset value is 15 Hz; factory default is 0 Hz), then press the Jog dial once to save the setting. The enclosed drive LL setting is now complete. Press the ESC to return to the MAIN MENU.

Refer to the *Altivar 212 Programming and Operation Guide*, S1A53838.

#### 21. The application may require changing the setting of acceleration (ACC) and deceleration (dEC) times. The preset value is 60 seconds. If the power converter has been replaced or reset to the factory default, the value is model dependent. Refer to the *Altivar 212 Programming and Operation Guide*, S1A53838, for information about the settings.

## Adjusting Mag-Gard or PowerPact Magnetic Trip Setting

The adjustable magnetic trip setting is factory-set at Lo for Mag-Gard Motor Circuit Protectors. For PowerPact Motor Circuit Protectors, the Full Load Amp (FLA) Setting is factory set to the lowest position and the Instantaneous Trip Setting (Im) is factory set to the Auto 1 position. These settings may have to be adjusted for proper motor start-up. For both Mag-Gard and PowerPact Motor Circuit Protectors, refer to the magnetic trip setpoint limits outlined in the applicable national standards. For PowerPact Motor Circuit Protectors, also refer to the *PowerPact Motor Circuit Protector Settings* instruction bulletin (48940-260-01) shipped with the equipment. Some units include thermal-magnetic circuit breakers which do not require any adjustment.

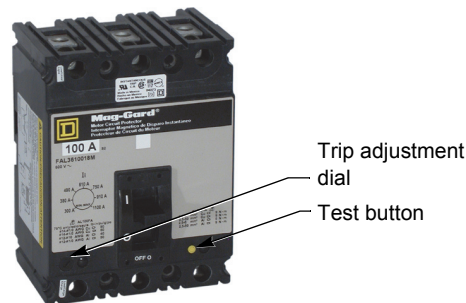
**⚠ DANGER**

**HAZARD OF ELECTRIC SHOCK, EXPLOSION, OR ARC FLASH**

- Apply appropriate personal protective equipment (PPE) and follow safe electrical work practices. See NFPA 70E®, CSA Z462, NOM-029-STPS, and other applicable regulations defining safe electrical work practices.
- This equipment must only be installed and serviced by qualified electrical personnel.
- Turn off all power supplying this equipment before working on or inside equipment.
- Always use a properly rated voltage sensing device to confirm power is off.
- Replace all devices, doors, and covers before turning on power to this equipment.

**Failure to follow these instructions will result in death or serious injury.**

**Figure 44 – FH Mag-Gard Circuit Breaker Trip Adjustment**



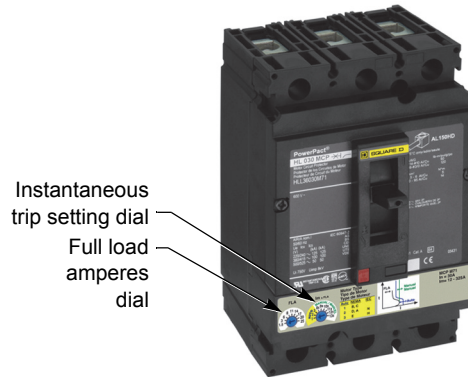
To access the Trip Adjustment dial on the FH Mag-Gard circuit breaker (if included):

1. Turn off all power supplying this equipment before working on or inside the equipment, and follow lockout/tagout procedures. Always use a properly rated voltage sensing device to confirm the power is off.
2. Place the unit handle in the Off position and open the door.

After obtaining the motor full load current from the motor nameplate, select an adjustable trip setpoint to test start the motor. Further adjustments may be required because of motor load characteristics. Refer to applicable national standards for permissible setpoints.

After adjusting the trip setting, reset the circuit breaker by moving the disconnect handle to the On position and then to the Off position.

**Figure 45 – PowerPact Circuit Breaker Trip Adjustment**



To access the Instantaneous Trip Setting (Im) and Full Load Amps (FLA) dials on the PowerPact circuit breaker (if included):

1. Turn off all power supplying this equipment before working on or inside the equipment, and follow lockout/tagout procedures. Always use a properly rated voltage sensing device to confirm the power is off.
2. Place the unit handle in the Off position and open the door.
3. To set the FLA and Im dials, refer to the PowerPact Motor Circuit Protector Settings instruction bulletin (48940-260-01) shipped with the equipment.

**NOTE:**

- These circuit breakers are suitable for motors with locked-rotor indicating code letters based on applicable national codes and standards. For other motors, consult your local Schneider Electric field sales representative.
- A fusible disconnect is provided with the 75 hp and 100 hp, 460 V enclosed drive instead of a circuit breaker.

## Fusible Disconnect

Due to wire routing you may need to disconnect the motor power conductors to access the fuses. When replacing fuses, torque the fuse bolts to 275 lb-in (31.1 N•m).

## Overload Relay Adjustment

Always verify that the overload relay setting does not exceed the motor full load current or rated current found on the S-Flex nameplate, whichever is less.

Table 17 provides the range of adjustment provided for overload relays according to horsepower rating and voltage. Contact the factory if the overload relay range or adjustment does not meet the intended application.

**Table 17 – Overload Relay Adjustment Range (Amperes)**

hp	208 V	230 V	460 V
1	4–6	4–6	1.6–2.5
2	5.5–8	5.5–8	2.5–4
3	9–13	7–10	4–6
5	12–18	12–18	7–10
7.5	23–32	16–24	9–13
10	23–32	23–32	12–18
15	37–50	37–50	16–24
20	48–65	48–65	23–32
25	63–80	63–80	30–40
30	80–104	80–104	30–40
40	90–150	95–120	48–65
50	—	—	63–80
60	—	—	63–80
75	—	—	95–120
100	—	—	90–150

## Section 4— Operation

<b>⚠ DANGER</b>
<b>HAZARD OF ELECTRIC SHOCK, EXPLOSION, OR ARC FLASH</b>
Read and understand the precautions in “Before You Begin” starting on page 8 before performing the procedures in this section.
<b>Failure to follow these instructions will result in death or serious injury.</b>

<b>⚠ DANGER</b>
<b>UNINTENDED EQUIPMENT OPERATION</b>
Before operating the S-Flex enclosed drives:
<ul style="list-style-type: none"><li>• Read and understand instruction bulletins S1A53832 and S1A53838 before changing any parameters from the factory defaults. See page 7 for list of instruction bulletins and information for obtaining them.</li><li>• Refer to Table 18 on page 88 for parameter setting sequence.</li><li>• If the power converter is re-initialized using the total or partial factory setting function, it must be reprogrammed to the values listed in Table 18 on page 88.</li><li>• If the power converter or the main control board of the power converter is replaced, the power converter must be reprogrammed according to the programming instructions in Table 18 on page 88.</li></ul>
<b>Failure to follow these instructions will result in death or serious injury.</b>

### Programming the Power Converter

The Altivar 212 power converters are factory configured as shown in Table 18. Be sure to configure the power converter’s motor full-load current as shown on the motor nameplate. For additional programming information, see the *Altivar 212 Programming and Operation Guide*, S1A53838, supplied with drive.

<b>⚠ WARNING</b>
<b>LOSS OF CONTROL</b>
Changes to factory set parameters must be completed in the sequence of appearance in Table 18 on page 88.
<b>Failure to follow these instructions can result in death, serious injury, or equipment damage.</b>

Changes to factory settings must be completed in the sequence of appearance in Table 18.

**Table 18 – Power Converter Factory Configuration (change factory set parameters according to table sequence)**

Parameter	Name	Unit	Description	Factory Setting	Customer Setting
<i>E Y P</i>	Parameter reset type	—	60 Hz	2	
<i>A U 1</i>	Auto ramp adaptation	—	Disable auto ramp	0	
<i>A C C</i>	Acceleration time 1	seconds	Acceleration time	60	
<i>d E C</i>	Deceleration time 1	seconds	Deceleration time	60	
<i>U L</i>	High speed	Hz	High speed	60	
<i>L L</i>	Low speed	Hz	Low speed	15	
<i>u L u</i>	Motor rated voltage	V	230/208 V models 460 V models	230/208 460	
<i>P t</i>	Motor control mode	—	Variable torque	1	
<i>t H r</i>	Motor rated current overload	A	Overload setting	100% of the drive's output rating	
<i>A U 4</i>	Macro programming See <i>Macro Programming</i> in the <i>Altivar 212 Programming and Operation Guide</i> , S1A53838.	—	Run permissive	1	
<i>F 1 3 0</i>	RC/RYC – RY/RYA relay primary function, Terminals 11 and 12 See <i>Relay Output Function</i> in the <i>Altivar 212 Programming and Operation Guide</i> , S1A53838.	—	Drive running	14	
<i>F 1 3 2</i>	FL relay function, Terminals 15 and 16 See <i>Relay Output Function</i> in the <i>Altivar 212 Programming and Operation Guide</i> , S1A53838.	—	Inversion of relay	11	
<i>F 2 0 1</i>	VIA speed reference level	%	4 mA minimum	20	
<i>F 6 0 5</i>	Output phase failure detection	—	Disabled	0	
<i>F 6 9 2</i>	Analog output bias	%	4 mA minimum	20	
<i>F 1 1 3</i>	LI Res Selection	—	SPEED REF	38	
<i>F 2 0 7</i>	Remote Speed Reference 2	—	HMI	3	

**Additional Factory Programming Configuration for Options A06, B06, C06, and D06**

Parameter	Name	Unit	Description	Factory Setting	Customer Setting
<i>F B 2 9</i>	Protocol	—	Modbus RTU	1	
			Metasys N2 (C06)	2	
			Apogee P1 (D06)	3	
			BACnet (A06)	4	
			LonWorks (B06)	5	
<i>C P 0 d</i>	Remote mode start/stop control source	—	Serial Communication	2	
<i>F P 0 d</i>	Remote mode primary speed reference source	—	Serial Communication	4	

**Adjustments to the Factory Programming Configuration to Allow Serial Communication Control Through the Modbus RJ-45 port**

<i>C P 0 d</i>	Remote mode start/stop control source	—	Serial Communication	2	
----------------	---------------------------------------	---	----------------------	---	--



**Table 18 – Power Converter Factory Configuration (change factory set parameters according to table sequence)**

Parameter	Name	Unit	Description	Factory Setting	Customer Setting
<i>F P D d</i>	Remote mode primary speed reference source	—	Serial Communication	4	
<i>F B 2 9</i>	Protocol	—	Modbus	1	

**Adjustments to the Factory Programming Configuration to Allow Monitoring Only Through Options A06, B06, C06, D06**

Parameter	Name	Unit	Description	Factory Setting	Customer Setting
<i>C P D d</i>	Remote mode start/stop control source	—	Terminals	0	
<i>F P D d</i>	Remote mode primary speed reference source	—	VIB	2	
<i>F I D B</i>	Always active logic function	—	Forced local	48	

## Power Circuit Y with Full Voltage Bypass

For power circuit Y with full voltage bypass, the S-Flex enclosed drive operates either by the power converter or at full-speed, full-voltage bypass. You can run the motor in bypass mode in the unlikely event that the power converter becomes inoperative.

The S-Flex enclosed drives consist of:

- An IEC-rated drive output and bypass contactor with electrical interlock and Class 10 overload relay
- A 120 Vac control power transformer (CPT)
- A Square D™ brand circuit breaker disconnect or fusible disconnect with the ability to lock in the open position
- AFC-Off-Bypass selector switch in Series D and
- Hand-Off-Auto and AFC-Bypass selector switches in Series E
- A power converter

Always verify that the overload relay is set to the motor full load current.

## Power Circuit W Without Bypass

For power circuit W without bypass, the S-Flex enclosed drive operates by the power converter only. This power circuit consists of a circuit breaker disconnect with means for locking in the open position, power converter, and optional equipment as specified.

## Operator Controls – General Arrangement and Operation

Operator controls are located on the front of the power converter and the control rail for Bypass Power Circuit Y. Selector switches and indicators are not supplied with Non-Bypass Power Circuit W.

A selector switch allows selection of power converter operation of the motor (AFC position) or line power operation of the motor (Bypass position).

**⚠ DANGER****UNINTENDED EQUIPMENT OPERATION**

Before turning on the drive or upon exiting the configuration menus, ensure that the inputs assigned to the Run command are in a state that will not cause the drive to run. Otherwise, the motor can start immediately.

**Failure to follow these instructions will result in death or serious injury.**

## AFC Operation

AFC operation allows control of the motor with the power converter. To set the S-Flex enclosed drive to AFC operation, close the enclosed drive disconnect switch located on the front of the enclosed drive. If the enclosed drive is equipped with bypass (power circuit Y), place the selector switch in the AFC position.

The power converter can be operated locally or remotely depending on the Loc/Rem key setting (integrated keypad) or F4 key setting (graphic keypad). When using the integrated keypad, if the green LED above the Loc/Rem key is illuminated, the power converter is operating in local mode. When the green LED is not illuminated, the power converter is operating in remote mode. When using the graphic keypad, LOCAL or REMOTE is displayed above the F4 key.

Control through serial communications is the default factory setting when a communication option is selected. The power converter responds to the run command and speed reference signals over the serial communications network. See Table 18 on page 88 for information about control through Modbus serial communications.

The RJ-45 Modbus port is occupied when the graphic keypad (D07) is selected.

## Non-Bypass Units (Power Circuit W)

Local control is achieved by placing the drive in local mode. The keypad Run and Stop keys can be used to start and stop the drive. Speed can be adjusted by pressing the UP and DOWN arrows on the integrated keypad, or by turning the Jog dial on the graphic keypad. The speed displays as output frequency in hertz.

In remote mode, a run command and speed reference signals can be sent to the power converter using either the logic input terminals or a serial communication network. See Table 15 and Figure 41 on page 72 for terminal designations for logic input terminals.

## Bypass Units (Power Circuit Y, Series D)

Control through the logic input terminals with the drive in remote mode is the default factory setting when no communication options are selected.

With the AFC-OFF-Bypass switch in the AFC position, start/stop functionality is available through the user-supplied auto start contact. Adjustable speed reference signals are sent to the power converter through the analog input terminals. See Table 13 and Figure 39 on page 70 for terminal designations for the logic input and speed reference terminals.

## **Bypass Units (Power Circuit Y, Series E)**

Control through the logic input terminals with the drive in remote mode is the default factory setting when no communication options are selected.

Local control is achieved via selector switches on the front of the enclosed drive. A local run command is provided to the drive when the AFC-Bypass selector switch is in the AFC position and the Hand-Off-Auto selector switch is placed in the Hand position. The drive keypad is the designated speed reference when the drive is running in this mode.

With the Hand-Off-Auto selector switch in the Auto position, start/stop functionality is available through the user-supplied auto start contact. Adjustable speed reference signals are sent to the power converter through the analog input terminals. See Table 14 and Figure 40 on page 71 for terminal designations for the logic input and speed reference terminals.

### **Bypass Operation**

Bypass operation allows control of the motor with line power. To set the S-Flex enclosed drive to bypass operation, close the enclosed drive disconnect switch located on the front of the enclosed drive and operate the selector switches to place the enclosed drive in bypass operation.

- For series D units, place the AFC-Off-Bypass switch in the Bypass position.
- For series E units, place the AFC-Bypass switch in the Bypass position and then move the Hand-Off-Auto switch to the Hand or Auto position for local or remote control operation in bypass.

This transfers motor operation to line power, full speed operation. Moving the selector switch to the Off position opens the bypass contactor and stops the motor.

### **UL® Type 3R Operation**

To prevent condensation on the inside of the cabinet, leave the S-Flex enclosed drive energized even when the motor is not running.

The enclosed drive has a UL 869A approved insulated ground neutral lug assembly and mounting bracket with a bonded enclosure ground wire suitable for use as service entrance rated equipment. Service Entrance Rating is not available when cUL is required.

### **Freeze/Firestat Interlocks (If Used)**

Terminals are provided to accept a user-supplied, normally-closed (N.C.) freeze/firestat interlock. Remove the factory-installed jumper from the terminals before installing the interlock. If the connection between the freeze/firestat terminals is open, the drive output contactor and the drive bypass contactor will open and cause the motor to coast. This feature can be used in conjunction with freeze sensors or in a firestat control system in accordance with NFPA (National Fire Protection Association) and local codes. See Table 13 on page 70 and Table 14 on page 71 for terminal numbers.

## Pilot Lights

Pilot lights visually indicate protective functions and circuit status. The LED ratings for the pilot lights is 120 Vac.

The functions of the two pilot lights are:

- Power On (red): illuminates when the enclosed drive disconnect is turned on. When pilot lights are not supplied, Power On is indicated by illumination of the power converter display.
- Bypass Run (green): illuminates while the enclosed drive is operating in bypass mode.

Pilot Lights are not available with Non-Bypass Power Circuit W.

## Auxiliary Drive Run Contact (Power Circuit W)

Provides a normally-open (N.O.) contact that closes to indicate when the motor is running in drive mode. See Table 15 on page 72 for terminal number designations.

**NOTE:** This contact is not available if LonWorks (option B06) is included in the unit.

## System Run Contact (Power Circuit Y)

Provides parallel normally-open (N.O.) contacts to indicate when the motor is running in drive mode or in full voltage bypass mode. See Table 13 on page 70 and Table 14 on page 71.

**NOTE:** If LonWorks (option B06) is included in the unit, the drive run indicating contact is not available, so the system run terminals will only indicate operation in bypass.

## Auxiliary Detected Fault Contact

Provides an N.C. contact between TB1–15 and TB1–16. Upon successful converter start-up, the contact will open and remain open until the drive detects a fault or is powered down.

## Damper Control

Available only on S-Flex enclosed drives with the integral full voltage bypass circuit. To enable damper control, remove the jumper between the terminals allocated for the damper switch. See Table 13 on page 70 and Table 14 on page 71.

### AFC Mode Bypass Units (Power Circuit Y, Series D)

In AFC mode, when the customer supplied auto start command contact is closed, a dry relay contact closes between terminals 19 and 20 that can be used by the customer to energize a damper actuator motor to open louvers that are closed when the enclosed drive is off.

### AFC Mode Bypass Units (Power Circuit Y, Series E)

In AFC mode, with the Hand-Off-Auto selector switch set to Hand, or with the switch set to Auto and with the customer supplied auto start command contact closed, a dry relay contact closes between terminals 19 and 20 that can be used by the customer to energize a damper actuator motor to open louvers that are closed when the enclosed drive is off.

### AFC Mode Bypass Units (Power Circuit Y, Series D and E)

When the damper reaches an Open position, the damper end switch must close to provide feedback to the drive. The drive will then run the motor. The drive will continue to run until the start signal is removed or the damper end switch is no

longer engaged. The fan motor will free wheel stop when the auto start signal, damper end switch or other installed interlocks are removed.

**NOTE:** The power for the damper motor must be supplied separately by the user.

**Bypass Mode Bypass Units  
(Power Circuit Y, Series D)**

When the S-Flex enclosed drive AFC-Off-Bypass selector switch is set to Bypass, the signal to the open the damper louvers is immediately made. When the damper end switch feedback is made, the bypass contactor will close. The motor will accelerate and run at line frequency speed until the Bypass switch is moved to the Off position, the damper end switch made signal is lost, or any other installed interlocks are removed.

**Bypass Mode Bypass Units  
(Power Circuit Y, Series E)**

When the S-Flex enclosed drive AFC-Bypass switch is set to Bypass and the Hand-Off-Auto switch is set to Hand the signal to operate the damper louvers is immediately made. With the switch set to Auto and the customer supplied auto start contact closed, the signal to operate damper louvers is immediately made. When the damper end switch feedback is made, the bypass contactor will close. The motor will accelerate and run at line frequency speed until the Hand-Off-Auto switch is moved to the Off position, the damper end switch made signal is lost, or any other installed interlocks are removed.

**Smoke Purge Function (Fireman's Override)**

Provides a smoke purge function which is controlled by a user-supplied, 120 Vac signal between terminals TB1-17 and TB1-18. Supplying 120 Vac to TB1-17 and TB1-18 transfers the motor operation to line power (if not operating in this mode already). This feature can be used in powered, smoke extract systems designed in accordance with NFPA and local codes. The Smoke Purge Function is not available with Non-Bypass Power Circuit W.

**Series D**

To disable the smoke purge function, remove the jumper between terminals TB1-9 and TB1-10 and install the jumper on terminals TB1-1 and TB1-2.

In the event that the smoke purge function is also enabled, the conditions described in "Damper Control" on page 92 are not active. The enclosed drive full voltage bypass will close immediately, accelerating to line frequency speed regardless of the damper end switch position. Any required interlocks to prohibit operation once smoke purge has been activated must be connected to terminals 9 and 10. This may include damper end switch, high static pressure switch, freeze/firestats or any other device which, when opened, disables the motor operation even during a smoke purge event. Control wiring can be used to wire these signals in series so that the interlocks are active in normal and purge modes of operation. See details on Smoke Purge Function (Fireman's Override) and Figure 46 (page 96) for information on wiring external signals to the S-Flex enclosed drive with Bypass.

**Series E**

The S-Flex 212 Series E enclosed drive is factory configured with the smoke purge function disabled. To enable the smoke purge function, remove the jumper between terminals TB1-3 and TB1-4 and install the jumper between terminals TB1-9 and TB1-10. See the terminal block information in Table 14 on page 71.

The control circuit for the Series E enclosed drive has terminal locations for connecting freeze/firestat (TB1-1 and TB1-2) and damper control (TB1-2 and TB1-3) interlocks in series with the smoke purge activation circuit. When used, these interlocks can prohibit smoke purge operation. Interlocks to prohibit smoke purge operation may also be connected between terminals 9 and 10. See Table 14 on page 71 for information on wiring external signals to the enclosed drive with bypass.

## Options

### MOD A06—BACnet

The equipment comes pre-programmed for interface with BACnet communication protocol.

### MOD A07—Drive Input Disconnect Switch

This option provides an input line power disconnect switch between the mains power disconnect and the power converter. The Drive Input Disconnect Switch will disconnect line power to the power converter. The motor can run in bypass mode in the unlikely event the power converter becomes inoperative.

### MOD B06—LonWorks

The equipment comes pre-programmed for interface with LonWorks communication protocol. A LonWorks serial communication card is installed VW3A21212.

### MOD B07—Line Contactor

This option provides an electrically interlocked line contactor between the mains power disconnect and the power converter. When the enclosed drive is in bypass mode, the line contactor disconnects line power from the power converter.

**NOTE:** Options A07 Drive Input Disconnect and B07 Line Contactor are available only when full voltage bypass option (Y05) is selected. Options A07 and B07 are mutually exclusive.

### MOD C06—Metasys N2

The equipment comes pre-programmed for interface with Metasys N2 communication protocol.

### MOD D06—Apogee P1

The equipment comes pre-programmed for interface with Apogee P1 communication protocol.

### MOD D07—Remote Graphic Keypad

This option provides a full-text door mounted graphic keypad with eight language options. With the graphic keypad, it is possible to display more detailed information than can be shown on the integrated keypad.

### MOD K07—50 °C Operation

Mod S14 provides a high ambient equipment rating above 40 °C (104 °F) to a maximum of 50 °C (122 °F).

### MOD N06—Modbus

The drive provides factory standard Modbus communications.

### MOD S07—Seismic Qualified

This option supplies a certification label indicating that the enclosure is qualified with seismic rating AC156 acceptance criteria test protocol with an importance factor of 1.5. Refer to *Seismic Qualification Mounting Criteria* on page 47.

**MOD T07—cUL Option**

This option provides cUL Certification for use in Canada. Please note that with cUL Certification, the service entrance lug is removed on Type 3R units.

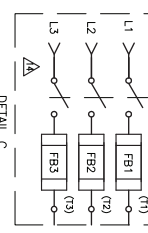
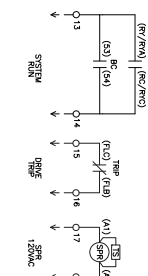
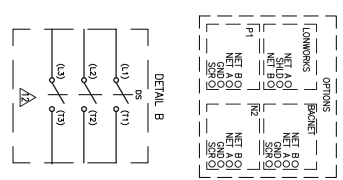
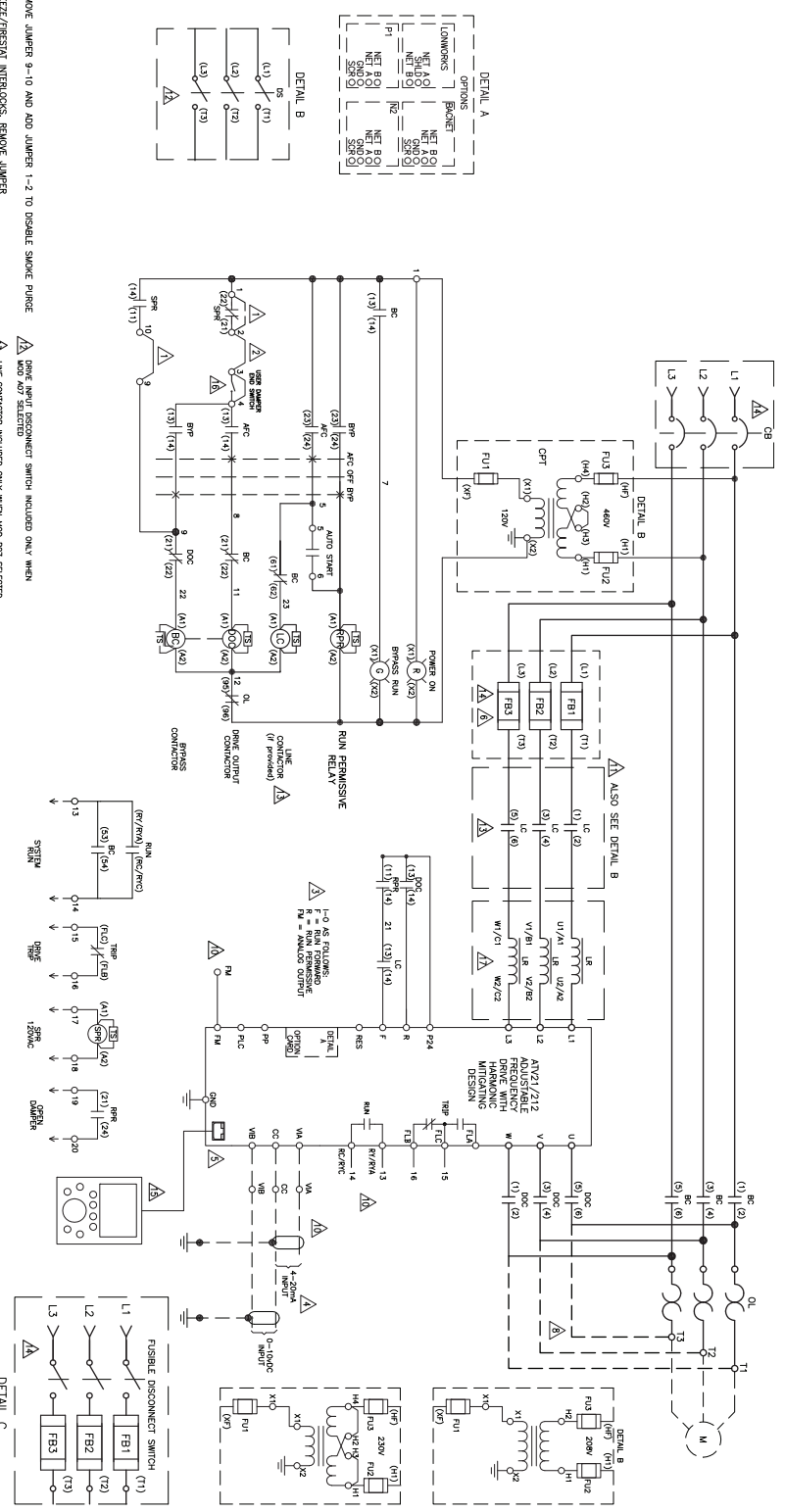
**MOD X07—Line Reactor**

This option provides an AC line reactor, mounted and wired in series with the power converter. The line reactor supplies some additional inductance to limit the impact of mains transients which may occur in electrical distribution systems.

# Wiring Diagrams

Figure 46 – Full Voltage Bypass Package, Enclosure Type 1, Power Circuit Y, Series D<sup>1</sup>

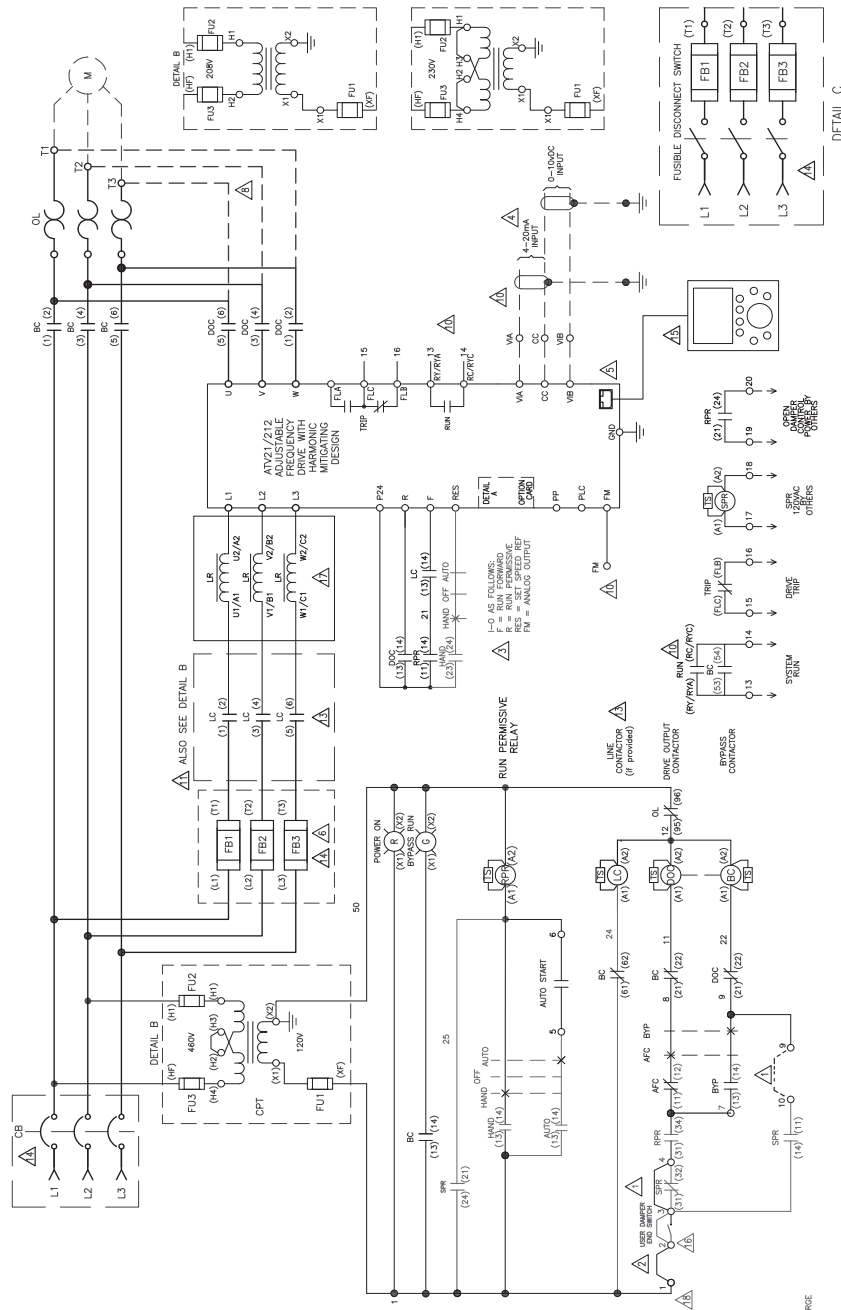
- NOTES:
- ▲ REMOVE JUMPER 9-10 AND ADD JUMPER 1-2 TO DISABLE SHOCK PURGE
  - ▲ FREEZE/THAW/STAIR INTERRUPTS. REMOVE JUMPER 30072-451-53
  - ▲ SET PROGRAMMING AND OPERATION GUIDE, 30072-451-53
  - ▲ TO CHANGE VOLTAGE TO A VOLTAGE ANALOG INPUT, MOVE OPERABLE SWITCH TO THE "V" POSITION
  - ▲ MODIFIS VIA R445 CONNECTION NAME TO ALL DRIVES
  - ▲ FIRES REQUIRED ON 480V MODELS ONLY. CONNECTER RANGE IN 3M
  - ▲ VARIABLE BIASED ON THE FOLLOWING:
    - 1. MEDIAN RFL
    - 2. MEDIAN RFL
    - 3. MEDIAN RFL
    - 4. MEDIAN RFL
  - ▲ WIRING CHANGE FOR 480V, 208V and 100V, 480V DRIVE
  - ▲ FOR WHEN MOD 406, 806, 006, 006, OR NATIVE MODIS IS REQUIRED FOR CONTROL. IF COMMUNICATION CABLES ARE USED FOR MONITORING ONLY, REFER TO INSTRUCTION SHEET 30072-451-53
  - ▲ NOT AVAILABLE WHEN OPTION 800 SELECTED.
  - ▲ DRIVE INPUT DISCONNECT SWITCH (MOD 407) AND LINE CONTACTOR OPTION (MOD 807) NOT AVAILABLE



<sup>1</sup> To identify the series, refer to the nameplate on the enclosed drive.



Figure 47 – Full Voltage Bypass Package, Enclosure Type 1, Power Circuit Y, Series E1

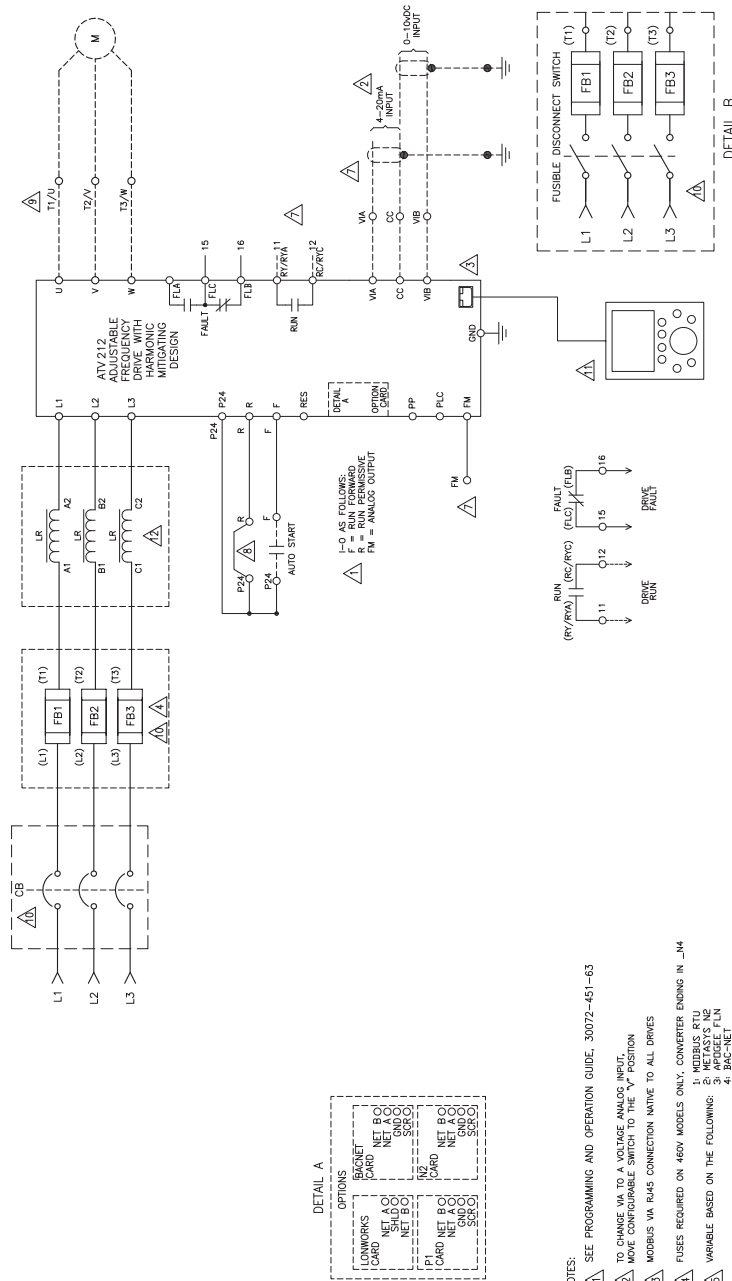


- △ REMOVE JUMPER 3-4 AND ADD JUMPER 9-10 TO ENABLE SMOKE PURGE
- △ FREEZE/PRESTAT INTERLOCKS: REMOVE JUMPER
- △ SEE PROGRAMMING AND OPERATION GUIDE, 30072-451-63
- △ TO CHANGE TO A 3-WIRE SMOKE PURGE, MOC CONFIGURABLE SWITCH TO THE "P" POSITION
- △ MOCBIS VIA R4/S CONNECTION WIRING TO ALL DRIVES
- △ FUSES REQUIRED ON 460V MODELS ONLY. CONVERTER ENDING IN „M“
- △ VARIABLE BASED ON THE FOLLOWING:
  - 1- MOCBIS R4/S
  - 2- MOCBIS R4/S
  - 3- MOCBIS R4/S
  - 4- MOCBIS R4/S
  - 5- MOCBIS R4/S
  - 6- MOCBIS R4/S
- △ WIRING CHANGE FOR 40HP, 200V and 100HP, 460V DRIVE
- △ FOR WHICH MOD 048, 008, 006, 005, OR MATE MOCBIS IS REQUIRED FOR CONTROL. IF
- △ COMMUNICATION CABLES ARE USED FOR MONITORING ONLY, REFER TO INSTRUCTION
- △ BULLETIN 30072-451-65
- △ MOCBIS VIA R4/S CONNECTION WIRING AND ANALOG OUTPUT ARE NOT PROVIDED. BOTH FUNCTIONS CAN BE MONITORED VIA LOWWORKS COMMUNICATIONS.
- △ DRIVE INPUT DISCONNECT SWITCH OPTION (MOD 407) AND LINE CONTACTOR OPTION (MOD 807) MUTUALLY EXCLUSIVE
- △ DRIVE INPUT DISCONNECT SWITCH INCLUDED ONLY WHEN MOD 407 SELECTED
- △ LINE CONTACTOR INCLUDED ONLY WHEN MOD 807 SELECTED
- △ FUSEABLE DISCONNECT SWITCH USED IN PLACE OF CIRCUIT BREAKER AND FUSE BLOCKS IN 75HP AND 100HP 460 VOLT UNITS
- △ REMOTE KEYPAD AVAILABLE WITH ATV212 DRIVE ONLY, WHEN OPTION D07 IS SELECTED.
- △ REMOVE JUMPER 2-3 TO ENABLE END DAMPER CONTROL
- △ LINE REACTOR INCLUDED ONLY WHEN MOD 107 IS SELECTED
- △ SMOKE PURGE SHALL DIVERSIFY WAVE WIDE AND RUN THE MOTOR IN BYPASS AT FULL SPEED DAMPER SWITCH INTERLOCKS IF USED WILL BE ACTIVE.

1 To identify the series, refer to the nameplate on the enclosed drive.



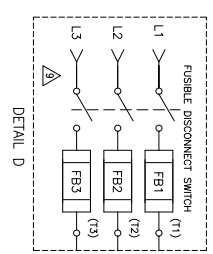
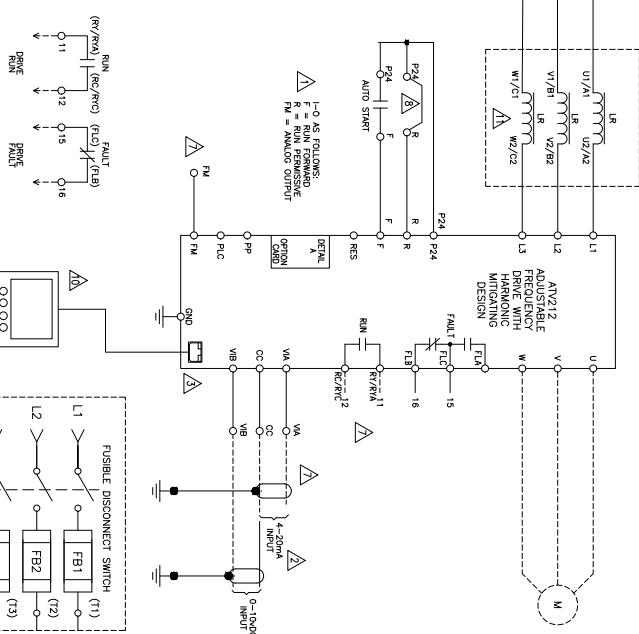
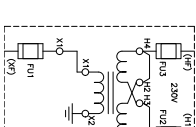
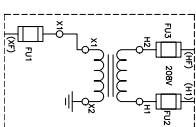
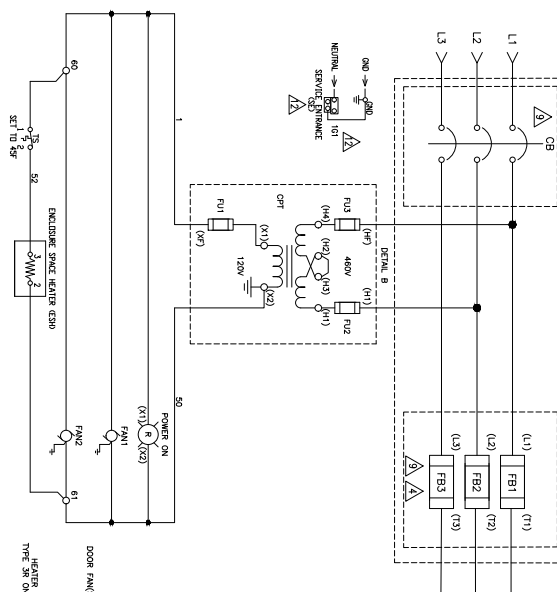
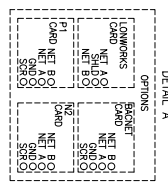
Figure 49 – Non-Bypass Package, Enclosure Type 1, Power Circuit W, 208/230 V and 460 V



- NOTES:
- 1. SEE PROGRAMMING AND OPERATION GUIDE, 30072-451-63
  - 2. TO CHANGE VA TO A VOLTAGE ANALOG INPUT, MOVE CONFIGURABLE SWITCH TO THE "V" POSITION
  - 3. MORBIS VA R445 CONNECTION APPLIES TO ALL DRIVES
  - 4. FUSES REQUIRED ON 460V MODELS ONLY. CONVERTER ENDING IN \_M4
  - 5. VARIABLE BASED ON THE FOLLOWING:
    - 1. MOTOR FLA
    - 2. NET/ASTS FLA
    - 3. APPELSE FLA
  - 6. FOR WHEN MOD 404, 404B, 404C, 404D, OR 404E. MORBIS IS REQUIRED FOR CONTROL. IF COMMUNICATION CARDS ARE USED FOR MONITORING ONLY, REFER TO INSTRUCTION BULLETIN 30072-451-83
  - 7. NOT AVAILABLE WHEN OPTION B06 IS SELECTED.
  - 8. FREEZE/FREESTAT INTERLOCKS. REMOVE JUMPER
  - 9. USE 0. 460V, 208/230V AND 75-100HP 480V SUPPLIED WITH TERMINAL BLOCK FOR CUSTOMER CONNECTION
  - 10. FUSIBLE DISCONNECT SWITCH USED IN PLACE OF CIRCUIT BREAKER AND FUSE BLOCKS ON 75 AND 100 HP 480 VOLT UNITS. SEE DETAIL B.
  - 11. REMOTE KEYPAD AVAILABLE WITH ATV212 DRIVE ONLY. WHEN OPTION D07 IS SELECTED.
  - 12. LINE REACTOR INCLUDED ONLY WHEN MOD X07 SELECTED

Figure 50 – Non-Bypass Package, Enclosure Type 12K or 3R, Power Circuit W, 208/230 V and 460 V

- NOTES:
- ▲ SEE PROGRAMMING MANUAL, S143838
  - ▲ TO CHANGE VA TO A VOLTAGE RANGE MORE WIDE, MORE CONSIDERABLE SWITCH TO THE "V" POSITION
  - ▲ MODES VIA R445 CONNECTION WIRE TO ALL DRIVES
  - ▲ FUSES REQUIRED ON ALL TYPE 12 OR 3R UNITS, MOD A03 OR MOD 30072-451-83
  - ▲ VARIABLE BASED ON THE FOLLOWING:
    1. MODELS R1U
    2. MODELS R2U
    3. MODEL R3U
    4. BAR-NET
 HOPUS IS REQUIRED FOR CONTROL. IF COMMUNICATION CABLES ARE USED FOR MONITORING ONLY, REFER TO INSTRUCTION BULLETIN 30072-451-83
  - ▲ WHEN OPTION FOR CURRENT IS SELECTED, ONE RUN CONTACT AND ANALOG OUTPUT ARE NOT AVAILABLE. REFER TO INSTRUCTION BULLETIN 30072-451-83 FOR CONNECTIONS
  - ▲ FREZEZ/PRESAT INTERLOCKS, RUNNER, STOPPER AND STOPPER CONTACTS, AND FUSE BLOCKS ON 50, 60, 75 AND 90 HP 460 VOLT UNITS AND 40 HP 208/230 VOLT UNITS, SEE DETAIL D
  - ▲ WINDING PROVIDED WITH MOD A03 OR MOD TYPE 12 OR 30. OPTIONAL WITH MOD 307 (TYPE 1)
  - ▲ LANE REACTOR INCLUDED ONLY WHEN MOD 307 SELECTED
  - ▲ SERVICE ENTRANCE PROVIDED WITH MOD H03 (TYPE 30) WITHOUT MOD K07 (G4)



## Section 5— Proportional–Integral–Derivative Control

### **⚠ DANGER**

#### **HAZARD OF ELECTRICAL SHOCK, EXPLOSION, OR ARC FLASH**

- Read and understand this manual before installing or operating the S-Flex enclosed drive. Installation, adjustment, repair, and maintenance must be performed by qualified personnel.
- The user is responsible for compliance with all national and local electrical code requirements with respect to grounding of all equipment.
- Many parts of this drive, including the printed circuit boards, operate at the line voltage. **DO NOT TOUCH.** Use only electrically insulated tools.
- **DO NOT** touch unshielded components or terminal strip screw connections with voltage present.
- **DO NOT** short across terminals PA/+ and PC/– or across the DC bus capacitors.
- Before servicing the enclosed drive:
  - Disconnect all power.
  - Place a “DO NOT TURN ON” label on all power disconnects.
  - Lock all power disconnects in the open position.
  - Disconnect all power, including external control power that may be present, before servicing the drive. **WAIT 15 MINUTES** to allow the DC bus capacitors to discharge. Then follow the “DC Bus Voltage Measurement Procedure” to verify that the DC voltage is less than 42 V. The drive LED is not an indicator of the absence of DC bus voltage.
- Install and close all covers before applying power or starting and stopping the enclosed drive.

**Failure to follow these instructions will result in death or serious injury.**

### **⚠ DANGER**

#### **UNINTENDED EQUIPMENT OPERATION**

- Test and ensure that any changes made to the parameter settings do not present any danger to personnel and equipment during the drive operation.
- Each control scheme must be individually and thoroughly tested for proper operation before being placed into service.

**Failure to follow these instructions will result in death or serious injury.**

## Introduction

This section provides programming instructions for using Proportional-Integral-Derivative (PID) control on the S-Flex adjustable speed drive.

PID control provides a method for controlling a process variable using a closed loop feedback system. The error between the desired setpoint and feedback process variable provides continuous corrective action to control the process output. From an application standpoint, the drive output adjusts the speed of the motor to reduce the error to zero. Closed loop control eliminates the cycling normally associated with open loop on-off control methods. PID control aims to regulate the process consistently under changing conditions at a maximum rate with minimum waste and minimum cost of operation.

Process variables such as temperature, pressure, and level can be monitored by the drive as a current or voltage analog feedback signal. The PID regulator calculates the error between the setpoint and feedback for a closed loop, then applies an appropriate frequency reference to adjust the motor speed.

There are three control functions:

1. Proportional (P): The Proportional function determines the responsiveness of control or how quickly the output reacts to the error.
2. Integral (I): The Integral function determines the reaction based on the sum of recent errors and its absence may prevent the system from reaching its target value.
3. Derivative (D): The Derivative function determines the reaction to the rate at which the error has been changing and is very sensitive to measurement noise.

The weighted sum of P, I, and D functions is used to correct the process variable.

By tuning these three functions, the system performance including responsiveness (time to correct the error), overshoot (overage from the reference setpoint) and oscillations (cycling between the highest and lowest point until signal stabilization) can be controlled.

**Figure 51 – PID Control Concept**

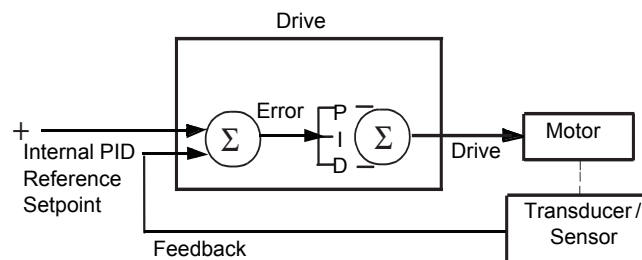
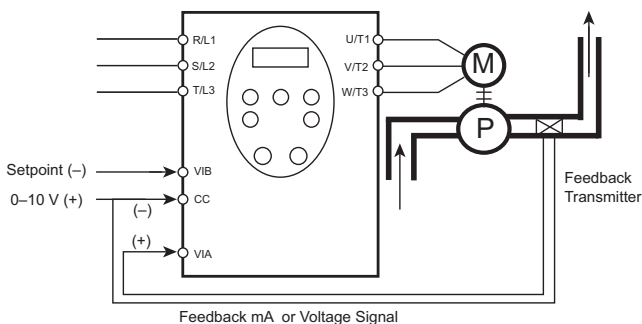


Figure 52 – PID Setup for Drive



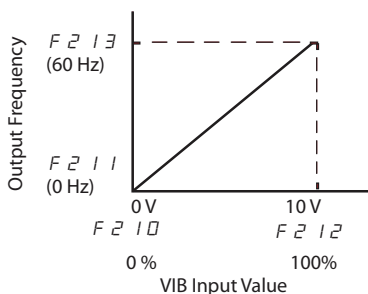
### Scaling of PID Parameters

Scaling of PID parameters is required to suit a customer’s application or range of the sensor input device providing the feedback signal (or both). Some examples of PID parameters and their ranges are pressure (0 to 20 psi), flow (0 to 500 gpm), and temperature (–100 °F to 300 °F).

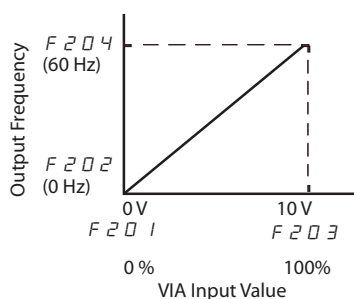
SPEED REFERENCE LEVEL 1 and 2 parameters must be entered as a percentage of the analog input range (VIA or VIB) used as the feedback input signal. The OUTPUT FREQUENCY LEVEL 1 and 2 parameters are entered in Hz and set as a function of the speed reference (see Figure 53).

Figure 53 – Examples of Terminal Setting

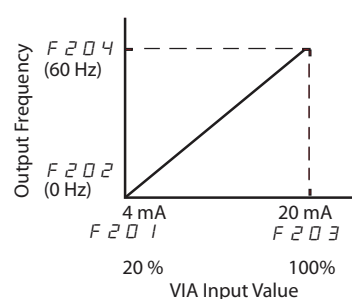
Example of VIB Terminal Setting



Example of VIA Terminal Setting (voltage input)



Example of VIA Terminal Setting (current input)



SPEED REFERENCE LEVEL parameter:

For a 4–6 V signal, set Speed Reference Level 1 to 40 and Speed Reference Level 2 to 60. Figure 53 illustrates scaling for a voltage signal of 0–10 V and a current signal of 4–20 mA.

OUTPUT FREQUENCY LEVEL parameter:

For an Output Frequency of 0–60 Hz, set Output Frequency Level 1 to 0 and Output Frequency Level 2 to 60.

## PID Tuning

Tuning of the P, I, and D control functions is required to optimize the process performance based on application needs. There are several methods for tuning including manual, Ziegler-Nichols, and by using several software tools available in the market. The PID proportional gain (F362), Integral gain (F363) and derivative gain (F366) parameters can be adjusted to allow the PID regulator to be tuned for a specific application.

**NOTE:** Follow the instructions in *Drive Configuration via Integrated or Graphic Keypad* on page 106 to set-up the P, I, and D control functions and access the parameters for gains adjustment.

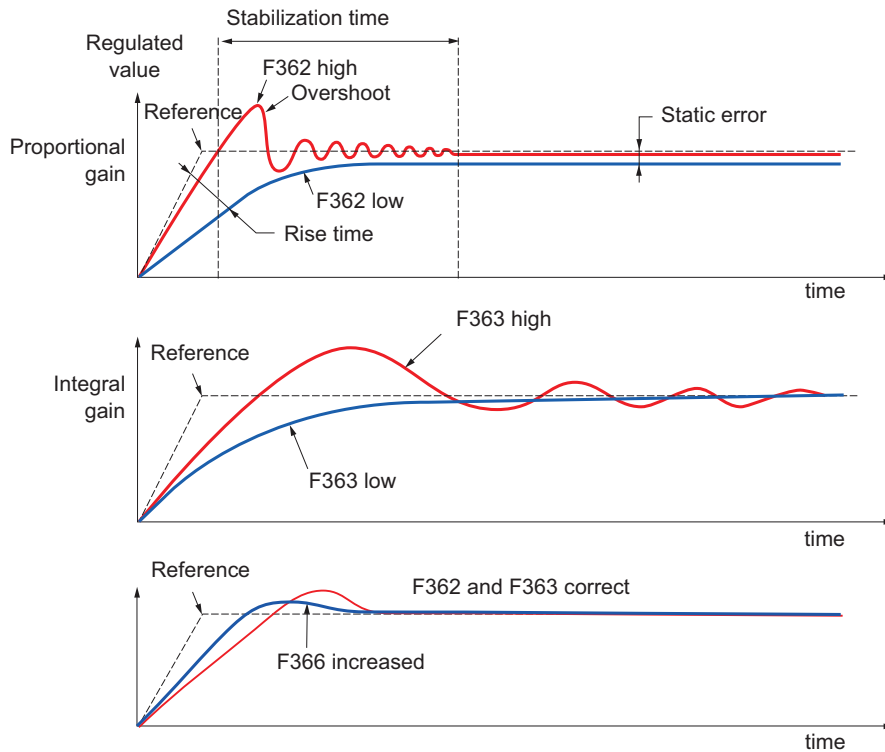
In many cases the factory settings for these parameters will be sufficient. However, if necessary, adjustments should be gradual and independent. If the system is unstable with the factory settings or the PID reference (setpoint) is not achieved, use the manual method described below:

- Set the integral gain (F363) to minimum.
- Leave the derivative gain (F366) at 0.
- Vary the load or PID reference setpoint a number of times and observe the PID regulator response.
- Set the proportional gain (F362) in order to obtain the best compromise between response time and stability.
- Once stable, if the steady state response varies from the preset value (setpoint), gradually increase the integral gain (F363), reduce the proportional gain (F362) in the event of instability (pump applications), and find a compromise between response time and precision.
- Typically, the derivative gain (F366) is not required, but may permit the reduction of overshoot and the improvement of response time. This can make it more difficult to obtain a compromise in terms of stability since this depends on 3 gains. If F366 is adjusted then the F362 and F363 may require re-adjustment.

Figure 54 on page 105 illustrates the system performance with adjustments in P, I, and D gains.



**Figure 54 – System Performance With Adjustments in P, I, and D Gains**



The oscillation frequency depends on the system's physical parameters and natural response.

Parameter	Rise time	Overshoot	Stabilization time	Static error
F362 ↗	↘↘	↗	=	↘
F363 ↗	↘	↗↗	↗	↘↘
F366 ↗	=	↘	↘	=

## Setting PID Control

The procedure for setting PID control for analog inputs with 0–10 Vdc or 4–20 mA signal is described in this section.

For SFD21, PID control with 4–20 mA current feedback is only possible on enclosed drives without A06, B06, C06, D06 communication options selected.

For SFD212, PID control with 4–20 mA current feedback is only possible on enclosed drives without B06 communication options selected.

Ensure that the factory settings for the enclosed drive and motor parameters are set. For more information, refer to the *Altivar 212 Programming and Operation Guide*, S1A53838.

## Drive Configuration via Integrated or Graphic Keypad

With power applied to the enclosed drive and before applying a run command to the enclosed drive, use the keypad to do the following:

Programming by Integrated Keypad:

1. Press the MODE key until AUF displays; then press ENT.
2. Scroll using the UP and DOWN arrow keys until FMOd displays; then press ENT.
3. Use the UP and DOWN arrow keys to adjust the desired control source.  
*Procedure is continued on page 107.*

Programming by Graphic Keypad:

1. Press the ESC key to display the PROGRAMMING MENU and turn the Jog dial until FREQUENCY MODE SEL. (FMOd) is highlighted; then press the Jog dial.
2. Turn the Jog dial to adjust the desired control source, then press the Jog dial when the desired control source is highlighted.  
*Procedure is continued on page 107.*

**Table 19 – Parameters**

Parameter	Name	Setting
FMOd	Remote mode primary speed reference source (VIA)	1
	Remote mode primary speed reference source (VIB)	2
	Panel input setting Internal preset speed setting	3
	Remote mode primary speed reference source (Serial Comm.)	4

**NOTE:** VIA accepts a 0–10 Vdc voltage signal or a 4–20 mA current signal, VIB accepts a 0–10 Vdc voltage input signal. Refer to the *Altivar 212 Installation Guide*, S1A53832, for instructions on accessing SW3.

When operating with internal setpoint, the adjusted range is taken as a percentage value reference and not an actual speed value and may only be set between the lower speed limit (LL) and upper speed limit (UL). For example, if the intended reference output frequency is 30 Hz and UL is set for 60 Hz, the drive requires a reference signal corresponding to 50%. If LL is set to 30 Hz, the setpoint cannot be set below 50% using this method. Additional signal manipulation may be required to convert the fundamental output frequency to rotational speed, pressure, or flow.

**Programming by Integrated Keypad:**  
**Continued from Step 3 on page 106.**

4. Press the ENT key to save the selection and to exit the FMOd parameter.
5. Use the UP and DOWN arrow keys until F--- (extended parameters) displays; then press the ENT key.
6. Use the UP and DOWN arrows to select the appropriate parameter and press ENT to modify the parameter.

**Programming by Graphic Keypad:**  
**Continued from Step 2 on page 106.**

3. Turn the Jog dial until EXTENDED MENU (F---) is displayed; then press the Jog dial.
4. Turn the Jog dial to select the appropriate parameter and press the Jog dial to confirm the parameter setting.

**NOTE:** Press the ENT key after modifying each parameter value to save and exit the parameter value selection menu and return to the F--- menu.

## Control Loop Configuration

To enable PID control, configure the analog feedback signal to VIA or VIB as required based on the type of transducer feedback signal used.

If VIB is used as the speed reference, then enable VIA to be used as the feedback signal. Use the UP and DOWN arrow keys to adjust the following parameter using the rules in Table 20.

**Table 20 – Parameters**

Parameter	Name	Setting	Adjustment Range	Description
F360	PID Control Enable VIA (0–10 Vdc or 4–20 mA dc)	1	—	—
	PID Control Enable VIB (0–10 Vdc)	2	—	—
F362	PID Proportional Gain	—	0.01 to 100.0	Parameter F362 adjusts the proportional gain applied during PID control. The speed change applied to the motor is a correctional value proportional to the product of this parameter's setting and the process error.
F363	PID Integral Gain	—	0.01 to 100.0	Parameter F363 adjusts the integral gain applied during PID control. Any residual process errors that remain after correction by the proportional gain are cleared to zero over time by the integral gain function.
F366	PID Derivative Gain	—	0.00 to 2.55	Parameter F366 adjusts the derivative gain applied during PID control. This gain adjusts the response time of the drive to rapid changes in the process.

## Control Loop Configuration

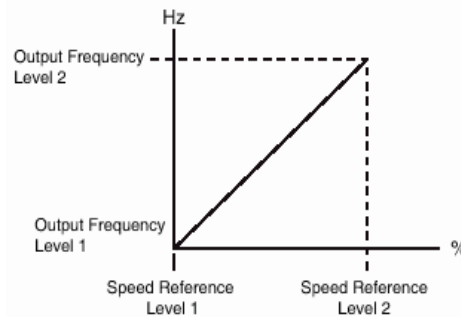
If FMod (FREQUENCY MODE SEL) is set to 2, adjust parameters F201–F204 (for analog input control from VIA) or F210–F213 (for analog input control from VIB) according to the ranges in Table 21 to define the performance characteristics of the drive.

**Table 21 – Analog Input Control Parameters**

Parameter	Name	Adjustment Range
F201	VIA reference point 1	0 to 100 (%)
F202	VIA frequency point 1	0 to 200 (Hz)
F203	VIA reference point 2	0 to 100 (%)
F204	VIA frequency point 2	0 to 200 (Hz)
F210	VIB reference point 1	0 to 100 (%)
F211	VIB frequency point 1	0 to 200 (Hz)
F212	VIB reference point 2	0 to 100 (%)
F213	VIB frequency point 2	0 to 200 (Hz)

Do not set the same frequency values for both VIA frequency points 1 (F202) and 2 (F204) or VIB frequency points 1 (F211) and 2 (F213). This will cause an Err1 error.

**Figure 55 – Analog Input Speed Reference and Output Frequency**



A refinement to the bias and slope of the analog input signals can be made with parameters F470–F473. Refer to the *Altivar 212 Programming and Operation Guide*, S1A53838.

## Sleep/Wake Operation

Parameter	Name	Adjustment Range
F256	Sleep/Wake Operation Time	0 to 600 (s)

Setting parameter F256 enables Sleep/Wake Operation. If the drive operates continuously at low speed (LL) for a time period equal to the setting of F256 in seconds, the drive will ramp the motor to a stop.

While the motor is stopped, LStP will flash on the drive keypad until a speed reference above LL is provided. The factory setting is 0, which disables this function. By default LL is set to 15 Hz and can be modified.

Refer to the *Altivar 212 Programming and Operation Guide*, S1A53838, for more information.

## PID Control Waiting Time

Parameter	Name	Adjustment Range
F359	PID Control Waiting Time	0 to 2400 s

By setting F359, the drive will not enter PID control until the time set by F359 has elapsed. The factory setting is 0, which disables this function. Factory default acceleration time is set at 60 seconds. If default acceleration time is changed or a factory reset is performed, adjust parameter F359 to match the desired acceleration and wait times.

Refer to the *Altivar 212 Programming and Operation Guide*, S1A53838, for more information.

## Attain Speed Relay

Attain Speed Relay is only compatible with analog feedback control. Refer to the *Altivar 212 Programming and Operation Guide*, S1A53838, for additional relay configurations and settings.

**Table 22 – Attain Speed Relay Parameters**

Parameter	Name	Setting	Adjustment Range	Description
F137	RYC–RYA Relay Secondary Function	60	—	To enable the run command signal relay (RA–RC and RYC–RYA) to include attain speed signal functionality, set parameter F137 to 60. The relay will only energize when the drive speed reference equals the VIB signal and a run command is received.
F167	Frequency command agreement detection range	—	0.0 to FH (Hz)	Parameter F167 determines the bandwidth around the VIB speed reference driving the relay output function.

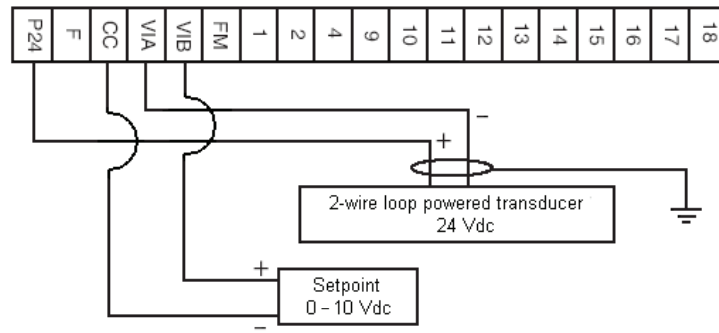
## Control Wiring

For analog PID control, wire terminals VIA, VIB, and CC as shown in Figure 56 (for two-wire loop powered) and in Figure 57 (for separately powered transducer).

- If the feedback is a 4–20 mA signal, set switch SW3 to the I (current) position.
- If the feedback is a 0–10 Vdc signal, set switch SW3 to the V (voltage) position.

Refer to the *Altivar 212 Installation Guide*, S1A53832, for instructions on accessing SW3.

**Figure 56 – Two-wire Loop Powered Transducer**



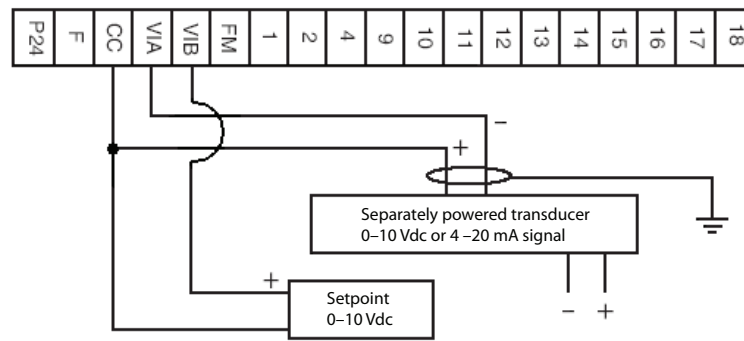
**⚠ CAUTION**

**UNINTENDED MOTOR SPEED**

Ensure adequate current for the transducer. The 24 Vdc power supply is current-limited to 200 mA. A load greater than the limit will cause the control voltage to dip and may result in erroneous readings from the transducer.

**Failure to follow these instructions can result in injury or equipment damage.**

**Figure 57 – Separately Powered Transducer**



Ground the shield only at one end to prevent large currents from flowing in the shield. The shield on the ungrounded end may be tied to ground with a capacitor (for example, 10 nF, 100 V or higher) to provide a path for the higher frequency noise.

## Application Notes

To set up the drive for a potentiometer using the drive supplied 10 Vdc supply or keypad speed reference, refer to the *Altivar 212 Installation Guide*, S1A53832, for additional details on power converter terminal block characteristics. Actual terminal arrangement and termination availability may vary depending on the communications option selected.

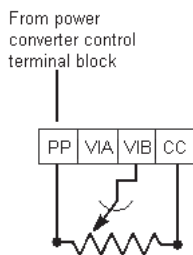
### Programming the PID Internal Setpoint with the Keypad

Set the following parameter: = FNOd to 3. This allows you to program the internal setpoint with the keypad.

When a run command is issued the default display for the drive will be the is output frequency.

Press the Up or Down arrow button while watching the gauge that shows the actual value. Once the actual value reaches the point you want to maintain, press enter. The setpoint will be shown on the display in a percentage between Low Speed (LL) and High Speed (UL). For example, 30 is 50%. See “Graphic Keypad Option (D07)” on page 75.

**Figure 58 – Control Terminals**



One internal 10 Vdc supply is accessible through terminal PP, integral to the power converter. Refer to Figure 58. The power supply is short-circuit and overload protected and capable of supplying up to 10 mA supply current. Size the reference potentiometer accordingly within a 1 to 10 k range. Connect the potentiometer as shown in Figure 58.

Set parameters CMOD and FMOd to the values shown in Table 23 to accept reference from the VIB terminal using the reference potentiometer.

**Table 23 – Parameters**

Parameter	Name	Setting
CMOD	Control terminal logic input	0
FMOd	Remote mode primary speed reference source (VIB)	2

To control the PID reference setpoint from the keypad, press the Loc/Rem key at any time and provide a speed reference command from the keypad display using the UP/DOWN arrows.

**NOTE:** Parameter F732 must be set to 0 to enable Loc/Rem.

Refer to the *Altivar 212 Programming and Operation Guide*, S1A53838, for more information.

## Section 6— Maintenance and Support

### Precautions

Before replacing any parts in the S-Flex enclosed drive, read and observe the following safety messages and all other safety messages provided in this bulletin.

#### **⚠ DANGER**

##### **HAZARD OF ELECTRIC SHOCK, EXPLOSION, OR ARC FLASH**

- Read and understand this instruction bulletin before installing or operating the S-Flex enclosed drive. Installation, adjustment, repair, and maintenance must be performed by qualified personnel.
- The user is responsible for compliance with all national and local electrical code requirements with respect to grounding of all equipment.
- Many parts of this drive, including the printed circuit boards, operate at the line voltage. **DO NOT TOUCH.** Use only electrically insulated tools.
- Some terminals have voltage on them when the disconnect is open.
- **DO NOT** short across terminals PA/+ and PC/- or across the DC bus capacitors.
- Before servicing the enclosed drive:
  - Disconnect all power including external control power that may be present before servicing the drive.
  - Place a “DO NOT TURN ON” label on the enclosed drive disconnect.
  - Lock disconnect in the open position.
  - **WAIT 15 MINUTES** to allow the DC bus capacitors to discharge. Then follow the “DC Bus Voltage Measurement Procedure” on page 56 to verify that the DC voltage is less than 42 V. The drive LEDs are not indicators of the absence of DC bus voltage.
- Install and close all covers and doors before applying power or starting and stopping the enclosed drive.

**Failure to follow these instructions will result in death or serious injury.**



**⚠ DANGER****HAZARD OF ELECTRIC SHOCK, EXPLOSION, OR ARC FLASH**

For Type 1, 460 V units and all Type 12 and 3R units:

- Apply appropriate personal protective equipment (PPE) and follow safe electrical work practices. See NFPA 70E®, CSA Z462, NOM-029-STPS, and other applicable regulations defining safe electrical work practices.
- This equipment must only be installed and serviced by qualified electrical personnel.
- Never operate energized switch with door open.
- Turn off switch before removing or installing fuses or making load side connections.
- Always use a properly rated voltage sensing device at all line and load fuse clips to confirm switch is off.
- Turn off power supplying switch before doing any other work on or inside switch.
- Do not use renewable link fuses in fused switches.

**Failure to follow these instructions will result in death or serious injury.**

**⚠ DANGER****HAZARD OF ELECTRIC SHOCK, EXPLOSION, OR ARC FLASH**

For Type 1, 208 and 230 V units:

- Apply appropriate personal protective equipment (PPE) and follow safe electrical work practices. See NFPA 70E®, CSA Z462, NOM-029-STPS, and other applicable regulations defining safe electrical work practices.
- This equipment must be installed and serviced only by qualified electrical personnel.
- Turn off all power supplying this equipment before working on or inside the equipment.
- Always use a properly rated voltage sensing device to confirm power is off.
- Replace all devices, doors and covers before turning on power to this equipment.

**Failure to follow these instructions will result in death or serious injury.**

**⚠ DANGER****UNINTENDED EQUIPMENT OPERATION**

Before turning on the drive or upon exiting the configuration menus, ensure that the inputs assigned to the Run command are in a state that will not cause the drive to run. Otherwise, the motor can start immediately.

**Failure to follow these instructions will result in death or serious injury.**

**▲ WARNING****LOSS OF CONTROL**

- The designer of any control scheme must consider the potential failure modes of control paths and, for certain critical control functions, provide a means to achieve a safe state during and after a path failure. Examples of critical control functions are emergency stop and overtravel stop.
- Separate or redundant control paths must be provided for critical control functions.
- System control paths may include communication links. Consideration must be given to the implications of anticipated transmission delays or failures of the link<sup>1</sup>.
- Each implementation of an S-Flex enclosed drive must be individually and thoroughly tested for proper operation before being placed into service.

**Failure to follow these instructions can result in death, serious injury, or equipment damage.**

<sup>1</sup> For additional information, refer to NEMA ICS 1.1 (latest edition), "Safety Guidelines for the Application, Installation, and Maintenance of Solid State Control" and to NEMA ICS 7.1 (latest edition), "Safety Standards for Construction and Guide for Selection, Installation and Operation of Adjustable-Speed Drive Systems."

**▲ CAUTION****INCOMPATIBLE LINE VOLTAGE**

Before turning on and configuring the enclosed drive, ensure that the line voltage is compatible with the line voltage range specified on the enclosed drive nameplate. The enclosed drive can be damaged if the line voltage is not compatible.

**Failure to follow these instructions can result in injury or equipment damage.**

## Diagnostic Codes

A number of diagnostic and status codes are included on the power converter. See the Troubleshooting Sheet on page 124. The graphic display terminal provides a visual indication of the enclosed drive’s operating and protective circuit functions, as well as indicator lights for maintenance and troubleshooting assistance.

If the enclosed drive trips while operating, the codes must be viewed before power is removed because removing power resets the detected fault code.

## External Signs of Damage

The following are signs of external damage:

- Cracked, charred, or damaged covers or enclosure parts
- Damage to the graphic display terminal such as scratches, punctures, burn marks, chemical burns, or moisture in the screen
- Oil or electrolyte on the bottom of the drive which might have leaked from the capacitors inside
- Excessive surface temperatures of enclosures and conduits
- Damage to power or control conductors
- Unusual noise or odors from any of the equipment
- Abnormal temperature, humidity, or vibration

If any of these signs are found while the equipment is powered up, immediately inform operating personnel and assess the risk of leaving the enclosed drive powered up. Before removing power from the equipment, always consult with the operating personnel responsible for the machinery and process.

## Preventive Maintenance

**Table 24 – Recommended Maintenance Intervals**

Inspection <sup>1</sup>	Interval (years)																			
	1	2	3	4	5	6	7	8	9	10	11	12	13	14	15	16	17	18	19	20
Line side terminals and torque				√				√				√				√				√
Load side terminals and torque				√				√				√				√				√
Plug-in connections				√				√				√				√				√
Relay contacts						√						√						√		
Circuit boards						√						√						√		
Insulation damage		√		√		√		√		√		√		√		√		√		√
Fiber optic cables				√				√				√				√				√
Oxidation, corrosion, dust	√	√	√	√	√	√	√	√	√	√	√	√	√	√	√	√	√	√	√	√
Power supply LEDs				√				√				√				√				√
Gasket						√						√						√		
DC-link capacitors						√						√						√		
Circuit breaker inspection				√				√				√				√				√
Spare part inspection				√				√				√				√				√
Air filter <sup>2</sup>	√	√	√	√	√	√	√	√	√	√	√	√	√	√	√	√	√	√	√	√
Heat sinks (dust and debris)		√		√		√		√		√		√		√		√		√		√
<b>Change</b>	<b>1</b>	<b>2</b>	<b>3</b>	<b>4</b>	<b>5</b>	<b>6</b>	<b>7</b>	<b>8</b>	<b>9</b>	<b>10</b>	<b>11</b>	<b>12</b>	<b>13</b>	<b>14</b>	<b>15</b>	<b>16</b>	<b>17</b>	<b>18</b>	<b>19</b>	<b>20</b>
Fan(s) for control electronics				√				√				√				√				√
Fan(s) for power electronics				√				√				√				√				√
Enclosure fan(s)				√				√				√				√				√

**Table 24 – Recommended Maintenance Intervals** (continued)

	Interval (years)																			
Service	1	2	3	4	5	6	7	8	9	10	11	12	13	14	15	16	17	18	19	20
DC-link capacitors												√								
Enclosure filters				√				√				√				√				√
Capacitor reforming				√				√				√				√				√
Thermography				√				√				√				√				√
Current symmetry				√				√				√				√				√
Check of parameter setting				√				√				√				√				√

<sup>1</sup> All service must be done with the enclosed drive in a non-energized state.

<sup>2</sup> Clear the fan filters once every six months.

### Inspection

Periodic inspection of the equipment is recommended to maintain the functionality over the course of its lifetime.

- Inspect the heatsink fans of the drive for blockage and impeded rotation. To prevent overheating and to allow proper air flow, maintain the clearances described on page 45.
- Examine the interior and exterior of the enclosed drive for moisture, oil, or other foreign material. Remove all foreign material and clean the enclosed drive.
- Clean the interior and exterior of the enclosed drive with a vacuum, do not use compressed air; it may distribute foreign contaminants to other surfaces.
- Check the enclosure for damage that might reduce electrical clearances.
- Examine the finish of the enclosure. Touch up the paint if necessary. Replace any badly oxidized, corroded or damaged enclosure parts.

### Maintenance after a Downstream Fault Has Occurred

Excessive currents during a downstream fault may result in component or conductor damage. This damage is caused by mechanical distortion, thermal damage, metal deposits, or smoke from downstream short circuit or thermal overload currents.

After a downstream fault, locate and correct the cause of the fault. Inspect all equipment and make any necessary repairs or replacements before putting the equipment back into service. Make sure all replacement parts are rated properly and are suitable for the application. If in doubt, consult your Schneider Electric field sales representative.

After any downstream fault, perform the following maintenance procedures:

1. Examine the enclosure. External evidence of enclosure damage usually indicates damage within. Extensive damage requires replacement of the enclosure parts or the equipment entirely.
2. Replace any parts that are damaged or deformed. Pay particular attention to door hinges and door closing hardware. Inspect the area around any damaged units (both inside and out) for displaced parts from the damaged unit.
3. Examine all conductors and tighten all electrical connections to their proper torque values. Replace any damaged conductors, as well as any showing signs of arcing damage. Inspect all insulators for cracks or burn marks and replace any displaying these characteristics.

## Circuit Breaker Maintenance

Some S-Flex enclosed drives are supplied with circuit breakers. Before performing any test or maintenance on the circuit breaker, locate the upstream disconnecting device and lock-out the power feeding the circuit breaker.

Press the push-to-trip button once a year to exercise the circuit breaker. Do not perform this test under load.

**NOTE:** The push-to-trip button will not function when the circuit breaker handle is in the Off (O) position.

## Servicing the Front Fan Filters (without Rain Hood)

### **⚠ DANGER**

#### **HAZARD OF ELECTRIC SHOCK, EXPLOSION, OR ARC FLASH**

- Apply appropriate personal protective equipment (PPE) and follow safe electrical work practices. See NFPA 70E®, CSA Z462, NOM-029-STPS, and other applicable regulations defining safe electrical work practices.
- This equipment must only be installed and serviced by qualified electrical personnel.
- Turn off all power supplying this equipment before working on or inside equipment.
- Always use a properly rated voltage sensing device to confirm power is off.
- Replace all devices, doors, and covers before turning on power to this equipment.

**Failure to follow these instructions will result in death or serious injury.**

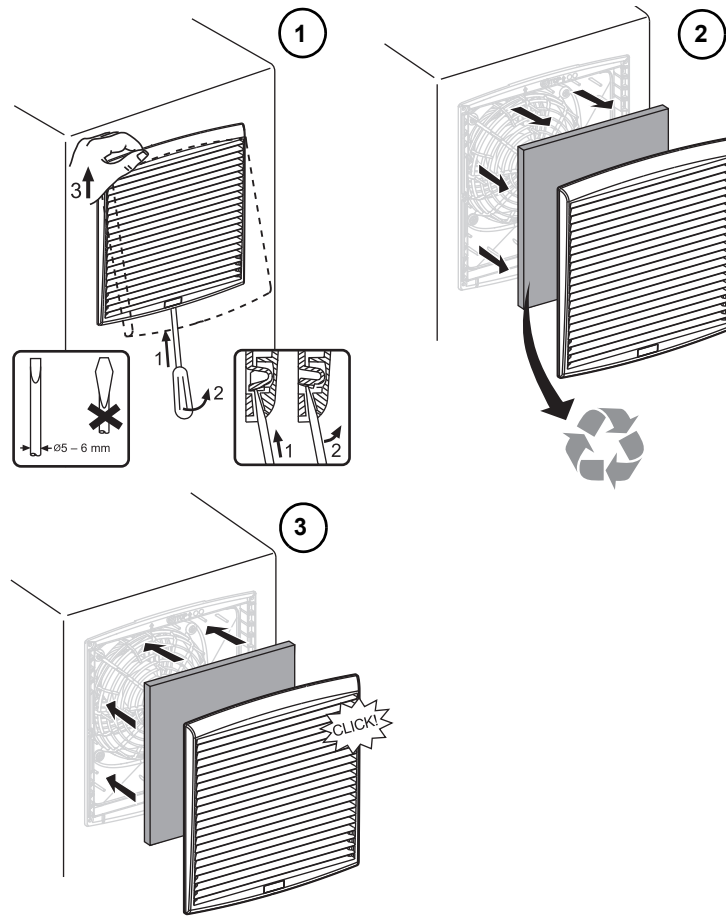
The S-Flex 212 enclosed drive includes filtered forced air ventilation that prevents excess dust or debris from entering the enclosure. The filters require periodic maintenance and replacement. Replacement or cleaning of filters is suggested once every six months at minimum, but the frequency may increase depending on a number of environmental factors. Select a maintenance cycle that is appropriate for your installation conditions.

1. Remove all power from the enclosed drive.
2. Turn the circuit breaker and handle assembly to the Off position and open the enclosure door.
3. Test for the absence of voltage.

**NOTE:** Verify that the voltage tester is functioning properly before and after testing for the absence of voltage.

4. Unlock the air outlet grill with a flat head screwdriver and lift the grill to the top. See Figure 59 on page 118.
5. Remove the grill and filter mat. Discard the filter mat.
6. Press the air outlet grill and the new filter mat into the cut out until it locks with an audible noise.

Figure 59 – Changing the Front Filters



## Servicing the Exhaust Fan Filter

### **⚠ DANGER**

#### **HAZARD OF ELECTRIC SHOCK, EXPLOSION, OR ARC FLASH**

- Apply appropriate personal protective equipment (PPE) and follow safe electrical work practices. See NFPA 70E®, CSA Z462, NOM-029-STPS, and other applicable regulations defining safe electrical work practices.
- This equipment must only be installed and serviced by qualified electrical personnel.
- Turn off all power supplying this equipment before working on or inside equipment.
- Always use a properly rated voltage sensing device to confirm power is off.
- Replace all devices, doors, and covers before turning on power to this equipment.

**Failure to follow these instructions will result in death or serious injury.**

Service of the exhaust filter is typically not required unless environmental conditions are especially dusty or the equipment has not been operated for an extended period of time. To access the exhaust fan filter:

1. Remove all power from the enclosed drive.
2. Turn the circuit breaker and handle assembly to the Off position and open the enclosure door.
3. Test for the absence of voltage.

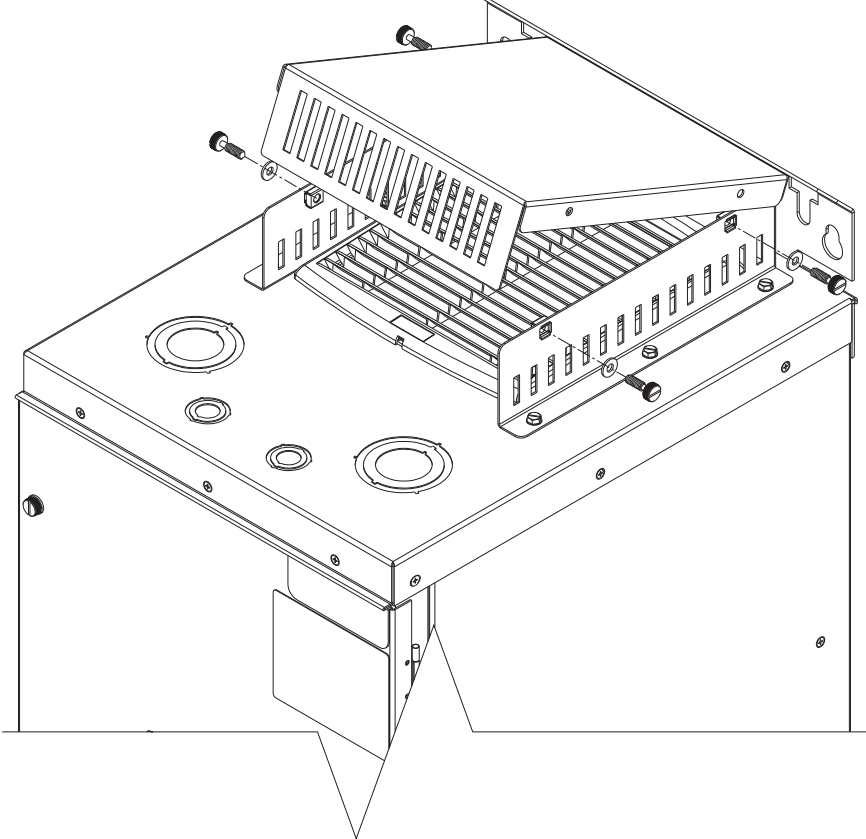
**NOTE:** Verify that the voltage tester is functioning properly before and after testing for the absence of voltage.

4. For Type 3R equipment, it is necessary to remove the rain hood. Remove the four thumb screws and lift the rain hood off the brackets. After servicing, replace the rain hood and hand tighten the thumb screws.

For Type 12K equipment, remove the vent grill as illustrated in Figure 60.

5. Service (clean or replace) the exhaust fan filter following the instructions on page 117 for the front filters. Always replace the rain hood or top cover and thumb screws after cleaning or replacing the filter.

Figure 60 – Accessing the Exhaust Fan Filters on Type 12K Equipment





## Replacing the Door Fans

### **⚠ DANGER**

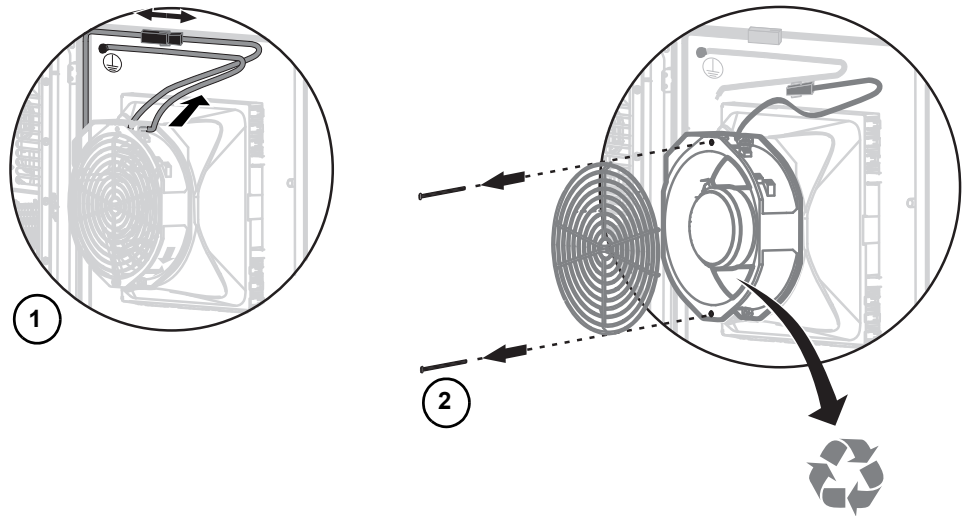
#### **HAZARD OF ELECTRIC SHOCK, EXPLOSION, OR ARC FLASH**

- Apply appropriate personal protective equipment (PPE) and follow safe electrical work practices. See NFPA 70E®, CSA Z462, NOM-029-STPS, and other applicable regulations defining safe electrical work practices.
- This equipment must only be installed and serviced by qualified electrical personnel.
- Turn off all power supplying this equipment before working on or inside equipment.
- Always use a properly rated voltage sensing device to confirm power is off.
- Replace all devices, doors, and covers before turning on power to this equipment.

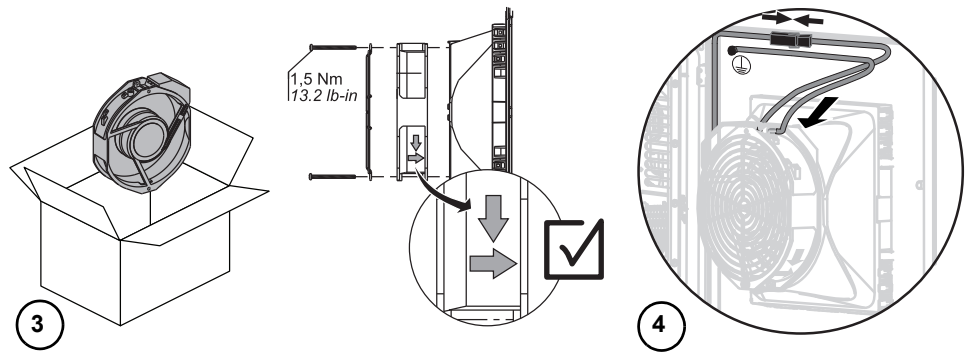
**Failure to follow these instructions will result in death or serious injury.**

1. Remove all power from the enclosed drive.
2. Turn the circuit breaker and handle assembly to the Off position and open the enclosure door.
3. Test for the absence of voltage.  
**NOTE:** Verify that the voltage tester is functioning properly before and after testing for the absence of voltage.
4. Remove the grounding cable and disconnect the fan's power supply. See Figure 61 on page 122.
5. Remove two screws, lift the grill from the fan, and remove the fan from the housing. Discard the fan but save the grill and screws to reinstall with the new fan.
6. Position the new fan so that the direction arrows point to the fan housing. Affix the fan and grill to the housing using the two screws. See Figure 62 on page 122.
7. Reconnect the fan's power supply and the grounding cable.

**Figure 61 – Removing the Door Fan**



**Figure 62 – Installing the New Door Fan**



## Technical Support

When troubleshooting the S-Flex enclosed drive, discuss the symptoms of the reported problems with operating personnel. Ask them to describe the problem, identify when they first observed the problem, and where the problem was seen.

Observe the drive system and process. Record the drive motor and peripheral equipment nameplate data on the Troubleshooting Sheet provided on page 124. Copy this form as needed.

For product post sale technical support please contact the Drive Products Support Group between the hours of 8:00 am and 8:00 pm Eastern time.

EMERGENCY technical phone support is available for inoperable machinery 24 hours a day, 365 days a year.

Toll free	1-888-778-2733 Option # 1 (Technical Support) and then Option # 4 (AC Drives and Soft Starters)
E-mail	drive.products.support@schneider-electric.com
Fax	919-217-6508

### Schneider Electric Services (On-Site)

The Schneider Electric Services division is committed to providing quality, on-site service that consistently meets customer expectations. Services responds to your requests, seven days a week, 24 hours a day.

Toll free: 1-888-778-2733

### Schneider Electric Customer Training

Schneider Electric offers a variety of instructor-led, skill enhancing and technical product training programs for customers. For a complete list of drives/soft start training with dates, locations, and pricing, please call:

Phone: 866-507-0894

Fax: 859-372-1565

### Product Literature

To view or download product literature, visit the Technical Library at [www.Schneider-Electric.com](http://www.Schneider-Electric.com).

### S-Flex 212 TROUBLESHOOTING SHEET

When requesting after-sales service, it is important to disclose all conditions under which the Schneider Electric equipment currently operates. This will help in diagnosing the system quickly.

**Call the Product Support Group at 888-778-2733.**

DATE: \_\_\_\_\_  
 CONTACT NAME: \_\_\_\_\_  
 COMPANY: \_\_\_\_\_  
 ADDRESS: \_\_\_\_\_  
 CITY: \_\_\_\_\_  
 STATE: \_\_\_\_\_  
 PHONE: \_\_\_\_\_  
 FAX: \_\_\_\_\_

#### ENCLOSED DRIVE CONFIGURATION

CATALOG NUMBER: TYPE **SFD212**:  
 APPLICATION/EQUIPMENT DESIGNATION:

#### MOTOR NAMEPLATE DATA

HORSEPOWER: \_\_\_\_\_ VOLTAGE (3 PHASE): \_\_\_\_\_ FREQUENCY: \_\_\_\_\_ RPM: \_\_\_\_\_ FLA: \_\_\_\_\_  
 SERVICE FACTOR: \_\_\_\_\_ MOTOR INSULATION:  NEW OR  EXISTING  
 MOTOR CABLE TYPE: \_\_\_\_\_ LENGTH IN FEET: \_\_\_\_\_  
 IS MOTOR DESIGNED TO COMPLY WITH NEMA MG-1 PART 31 GUIDELINES?  YES  NO

#### POWER SOURCE AND ENVIRONMENT

VOLTAGE BETWEEN: L1 AND L2: \_\_\_\_\_ L2 AND L3: \_\_\_\_\_ L3 AND L1: \_\_\_\_\_  
 SERVICE TRANSFORMER RATING: \_\_\_\_\_ KVA \_\_\_\_\_ % Z FREQUENCY:  60 HZ OR  50 HZ  
 AMBIENT TEMPERATURES: MIN °C (°F) \_\_\_\_\_ MAX °C (°F) \_\_\_\_\_ HUMIDITY: \_\_\_\_\_  
 ALTITUDE IF GREATER THAN 3300 FEET ABOVE SEA LEVEL, SPECIFY: \_\_\_\_\_ FT

#### DRIVE DETECTED FAULT CODES

Refer to *the Altivar 212 Programming and Operation Guide, S1A53838* for possible causes, corrective actions, and additional detected fault codes.

<input type="checkbox"/> <b>E-19</b> BREAK IN VIA SIGNAL CABLE	<input type="checkbox"/> <b>Err7</b> CURRENT SENSOR	<input type="checkbox"/> <b>OC3P</b> GROUND CONSTANT SPEED	<input type="checkbox"/> <b>OP1</b> OVERVOLTAGE ACCELERATION
<input type="checkbox"/> <b>E-21</b> CPU	<input type="checkbox"/> <b>EtYP</b> DRIVE TYPE	<input type="checkbox"/> <b>OCL</b> SHORT CIRCUIT	<input type="checkbox"/> <b>OP2</b> OVERVOLTAGE DECELERATION
<input type="checkbox"/> <b>EF2</b> GROUND FAULT	<input type="checkbox"/> <b>OC1</b> OVERCURRENT ACCELERATION	<input type="checkbox"/> <b>OH</b> OVERTEMPERATURE	<input type="checkbox"/> <b>OP3</b> OVERVOLTAGE CONSTANT SPEED
<input type="checkbox"/> <b>EPH1</b> INPUT PHASE LOSS	<input type="checkbox"/> <b>OC1P</b> GROUND FAULT ACCELERATION	<input type="checkbox"/> <b>OL1</b> DRIVE OVERLOAD	<input type="checkbox"/> <b>Ot</b> OVERTORQUE FAULT
<input type="checkbox"/> <b>EPH0</b> OUTPUT PHASE LOSS	<input type="checkbox"/> <b>OC2P</b> GROUND FAULT	<input type="checkbox"/> <b>OL2</b> MOTOR OVERLOAD	<input type="checkbox"/> <b>UC</b> UNDERLOAD FAULT

#### DETAILED DESCRIPTION OF PROBLEM

\_\_\_\_\_  
 \_\_\_\_\_  
 \_\_\_\_\_

## Renewable Parts

Schneider Electric provides a limited number of renewable parts for the Altivar 212 power converters and the S-Flex enclosed drives. Before replacing any parts, consult your local field sales representative. Renewable parts must be installed by qualified personnel.

**Table 25 – Recommended Renewable Parts**

Renewable Part	208 V Rating			230 V Rating			460 V Rating			
<b>Power Converter<sup>1</sup></b>										
	1 hp	ATV212H075M3X		ATV212H075M3X			ATV212H075N4			
	2 hp	ATV212HU15M3X		ATV212HU15M3X			ATV212HU15N4			
	3 hp	ATV212HU22M3X		ATV212HU22M3X			ATV212HU22N4			
	5 hp	ATV212HU40M3X		ATV212HU40M3X			ATV212HU40N4			
	7.5 hp	ATV212HU55M3X		ATV212HU55M3X			ATV212HU55N4			
	10 hp	ATV212HU75M3X		ATV212HU75M3X			ATV212HU75N4			
	15 hp	ATV212HD11M3X		ATV212HD11M3X			ATV212HD11N4			
	20 hp	ATV212HD15M3X		ATV212HD15M3X			ATV212HD15N4			
	25 hp	ATV212HD18M3X		ATV212HD18M3X			ATV212HD18N4			
	30 hp	ATV212HD22M3X		ATV212HD22M3X			ATV212HD22N4			
	40 hp	ATV212HD30M3X		ATV212HD30M3X			ATV212HD30N4			
	50 hp	—		—			ATV212HD37N4			
	60 hp	—		—			ATV212HD45N4			
	75 hp	—		—			ATV212HD55N4			
	100 hp	—		—			ATV212HD75N4			
<b>FB1, FB2, FB3 Power Fuses<sup>2</sup></b>										
		<b>Type 12K, 3R</b>			<b>Type 12K, 3R</b>			<b>Type 1, 12, 3R</b>		
		<b>Part Number</b>	<b>Rating (A)</b>	<b>Class</b>	<b>Part Number</b>	<b>Rating (A)</b>	<b>Class</b>	<b>Part Number</b>	<b>Rating (A)</b>	<b>Class</b>
	1 hp	25430-20800	8	CC	25430-20800	8	CC	25430-20300	3	CC
	2 hp	25430-21200	12	CC	25430-21000	10	CC	25430-20600	6	CC
	3 hp	25430-22000	20	CC	25430-21500	15	CC	25430-20700	7	CC
	5 hp	25430-22500	25	CC	25430-22500	25	CC	25430-21500	15	CC
	7.5 hp	25423-30400	40	J	25430-23000	30	CC	25430-21500	15	CC
	10 hp	25423-30500	50	J	25423-30400	40	J	25430-22000	20	CC
	15 hp	25423-30600	60	J	25423-30500	60	J	25430-23000	30	CC
	20 hp	25423-30900	90	J	25423-30900	90	J	25423-30400	40	J
	25 hp	25423-31000	100	J	25423-31000	100	J	25423-30500	50	J
	30 hp	25423-31250	125	J	25423-31000	100	J	25423-30600	60	J
	40 hp	25423-31750	175	J	25423-31500	150	J	25423-30800	80	J
	50 hp		—			—		25423-31000	100	J
	60 hp		—			—		25423-31000	100	J
	75 hp		—			—		25423-31500	150	J
	100 hp		—			—		25423-31750	175	J

**Table 25 – Recommended Renewable Parts** (continued)**Type 1 Enclosures (MOD G03)****FU2, FU3**

Control Power Transformer (Primary Fuse)	Part Number	Rating (A)	Class	Part Number	Rating (A)	Class	Part Number	Rating (A)	Class
100 VA	25430-20225 <sup>3</sup>	2.25	CC	FNQR2 <sup>3</sup>	2	CC	FNQR1 <sup>3</sup>	1	CC
150 VA	25430-20350 <sup>4</sup>	3.5	CC	25430-20321 <sup>4</sup>	3.2	CC	25430-20150 <sup>4</sup>	1.5	CC

**Type 1 Enclosures (MOD G03)****FU1**

Control Power Transformer (Secondary Fuse)	Part Number	Rating (A)	Class	Part Number	Rating (A)	Class	Part Number	Rating (A)	Class
100 VA	25430-20140 <sup>3</sup>	1.4	CC	25430-20140 <sup>3</sup>	1.4	CC	25430-20140 <sup>3</sup>	1.4	CC
150 VA	FNQR2 <sup>4</sup>	2	CC	FNQR2 <sup>4</sup>	2	CC	FNQR2 <sup>4</sup>	2	CC

**Type 12K or 3R Enclosures (MOD A03 or H03)****FU2, FU3**

Control Power Transformer (Primary Fuse)	Part Number	Rating (A)	Class	Part Number	Rating (A)	Class	Part Number	Rating (A)	Class
100 VA	25430-20225	2.25	CC	FNQR2	2	CC	FNQR1	1	CC
150 VA	25430-20350	3.5	CC	25430-20321	3.2	CC	25430-20150	1.5	CC
200 VA	FNQR2	2	CC	FNQR2	2	CC	FNQR1	1	CC
250 VA	25430-20300	3	CC	25430-20300	3	CC	25430-20150	1.5	CC
500 VA	25430-20400	4	CC	25430-20400	4	CC	FNQR2	2	CC
750 VA	25430-20500	5	CC	25430-20500	5	CC	25430-20400	4	CC

**Type 12K or 3R Enclosures (MOD A03 or H03)****FU1**

Control Power Transformer (Secondary Fuse)	Part Number	Rating (A)	Class	Part Number	Rating (A)	Class	Part Number	Rating (A)	Class
100 VA	25430-20140	1.4	CC	25430-20140	1.4	CC	25430-20140	1.4	CC
150 VA	FNQR2	2	CC	FNQR2	2	CC	FNQR2	2	CC
200 VA	FNQR2	2	CC	FNQR2	2	CC	FNQR2	2	CC
250 VA	25430-20300	3	CC	25430-20300	3	CC	25430-20300	3	CC
500 VA	25430-20700	7	CC	25430-20700	7	CC	25430-20700	7	CC
750 VA	25430-21000	10	CC	25430-21000	10	CC	25430-21000	10	CC

<sup>1</sup> Drives shown in the table are installed in SFD212 enclosed drives.

<sup>2</sup> Use Class CC or J fast acting fuses. Control power transformer and fuses are supplied only with power circuit Y05 on Types 1, 12, and 3R and with power circuit W05 on Types 12 and 3R.

<sup>3</sup> Fuses are supplied for all power ratings with MOD G03 (Type 1) and without MOD B07 (Line Contactor). Fuses are supplied for 1 to 10 hp, 208/230 V, and 1 to 20 hp, 460 V, with MOD G03 and MOD B07.

<sup>4</sup> Fuses are supplied for 15 to 40 hp, 208/230 V, and 25 to 100 hp, 460 V with MOD G03 and MOD B07.

**Table 26 – Control Transformer Ratings (VA)**

S-Flex Enclosed Drive Catalog Number <sup>1</sup>	Input Voltage (60 Vac)	Horsepower Rating (hp)	Type 12K W05	Type 12K Y05	Type 3R W05	Type 3R Y05
SFD212C•2	208	1	100	200	250	250
SFD212D•2		2	100	200	250	250
SFD212E•2		3	100	200	250	250
SFD212F•2		5	100	200	250	250
SFD212G•2		7.5	100	200	250	500
SFD212H•2		10	100	200	250	500
SFD212J•2		15	100	200	250	500
SFD212K•2		20	100	200	250	500
SFD212L•2		25	100	200	250	500
SFD212M•2		30	100	200	250	500
SFD212N•2		40	200	250	500	750
SFD212C•3		230	1	100	200	250
SFD212D•3	2		100	200	250	250
SFD212E•3	3		100	200	250	250
SFD212F•3	5		100	200	250	250
SFD212G•3	7.5		100	200	250	500
SFD212H•3	10		100	200	250	500
SFD212J•3	15		100	200	250	500
SFD212K•3	20		100	200	250	500
SFD212L•3	25		100	200	250	500
SFD212M•3	30		100	200	250	500
SFD212N•3	40		200	250	500	750
SFD212C•4	460		1	100	200	250
SFD212D•4		2	100	200	250	250
SFD212E•4		3	100	200	250	250
SFD212F•4		5	100	200	250	250
SFD212G•4		7.5	100	200	250	500
SFD212H•4		10	100	200	250	500
SFD212J•4		15	100	200	250	500
SFD212K•4		20	100	200	250	500
SFD212L•4		25	100	200	250	500
SFD212M•4		30	100	200	250	500
SFD212N•4		40	100	200	250	500
SFD212P•4		50	200	250	500	750
SFD212Q•4		60	200	250	500	750
SFD212R•4		75	200	250	500	750
SFD212S•4		100	200	250	500	750

<sup>1</sup> The “•” indicates the enclosure type: “A” = Type 12K, “G” = Type 1, and “H” = Type 3R.

The “\*” indicates that the catalog number can end in a “Y” (for an S-Flex enclosed drive with full voltage bypass) or a “W” (for an S-Flex enclosed drive without bypass).

**Table 27 – Type 1 S-Flex Bypass Circuit Power Component Renewable Parts (Mod Y Only), Square D Catalog Numbers**

S-Flex Enclosed Drive Catalog Number	Input Voltage (60 Hz Vac)	Horsepower Rating (hp)	Main Circuit Breaker	Drive Input, Drive Output, or Bypass Contactor	Motor Overload Relay	
SFD212CG2	208	1	HLL36015LV	LC1D25G7	LRD10	
SFD212DG2		2	HLL36020LV	LC1D25G7	LRD12	
SFD212EG2		3	HLL36025LV	LC1D25G7	LRD16	
SFD212FG2		5	HLL36040LV	LC1D25G7	LRD21	
SFD212GG2		7.5	HLL36060LV	LC1D32G7	LRD32	
SFD212HG2		10	HLL36080LV	LC1D32G7	LRD32	
SFD212JG2		15	HLL36110LV	LC1D50AG7	LRD350	
SFD212KG2		20	HLL36150LV	LC1D65AG7	LRD365	
SFD212LG2		25	HLL36100M73LV	LC1D80G7	LRD3363	
SFD212MG2		30	HLL36150M74LV	LC1D115G7	LRD4365	
SFD212NG2		40	HLL36150M74LV	LC1D150G7	LR9D5369	
SFD212CG3		230	1	HLL36015LV	LC1D25G7	LRD10
SFD212DG3			2	HLL36020LV	LC1D25G7	LRD12
SFD212EG3			3	HLL36025LV	LC1D25G7	LRD14
SFD212FG3	5		HLL36035LV	LC1D25G7	LRD21	
SFD212GG3	7.5		HLL36060LV	LC1D32G7	LRD22	
SFD212HG3	10		HLL36070LV	LC1D32G7	LRD32	
SFD212JG3	15		HLL36100LV	LC1D50AG7	LRD350	
SFD212KG3	20		HLL36125LV	LC1D65AG7	LRD365	
SFD212LG3	25		HLL36100M73LV	LC1D80G7	LRD3363	
SFD212MG3	30		HLL36150M74LV	LC1D115G7	LRD4365	
SFD212NG3	40	HLL36150M74LV	LC1D150G7	LRD4367		
SFD212CG4	460	1	HLL36015LV	LC1D25G7	LRD07	
SFD212DG4		2	HLL36015LV	LC1D25G7	LRD08	
SFD212EG4		3	HLL36015LV	LC1D25G7	LRD10	
SFD212FG4		5	HLL36020LV	LC1D25G7	LRD14	
SFD212GG4		7.5	HLL36025LV	LC1D25G7	LRD16	
SFD212HG4		10	HLL36035LV	LC1D25G7	LRD21	
SFD212JG4		15	HLL36050LV	LC1D32G7	LRD22	
SFD212KG4		20	HLL36060LV	LC1D32G7	LRD32	
SFD212LG4		25	HLL36080LV	LC1D50AG7	LRD340	
SFD212MG4		30	HLL36100LV	LC1D50AG7	LRD340	
SFD212NG4		40	HLL36125LV	LC1D65AG7	LRD365	
SFD212PG4		50	HLL36150LV	LC1D80G7	LRD3363	
SFD212QG4		60	HLL36100M73LV	LC1D80G7	LRD3363	
SFD212RG4		75	GS2MLU3N <sup>1</sup>	LC1D150G7	LRD4367	
SFD212SG4		100	GS2MLU3N <sup>1</sup>	LC1D150G7	LR9D5369	

<sup>1</sup> Fusible Switch used for these power ratings instead of main circuit breaker.



**Table 28 – Type 12K or 3R S-Flex Circuit Power Component Renewable Parts (Mod Y Only), Square D Catalog Numbers**

S-Flex Enclosed Drive Catalog Number <sup>1</sup>	Input Voltage (60 Hz Vac)	Horsepower Rating (hp)	Main Circuit Breaker	Drive Input, Drive Output, or Bypass Contactor	Motor Overload Relay
SFD212C•2	208	1	HLL36015LU	LC1D25G7	LRD10
SFD212D•2		2	HLL36020LU	LC1D25G7	LRD12
SFD212E•2		3	HLL36025LU	LC1D25G7	LRD16
SFD212F•2		5	HLL36040LU	LC1D25G7	LRD21
SFD212G•2		7.5	HLL36060LU	LC1D32G7	LRD32
SFD212H•2		10	HLL36080LU	LC1D32G7	LRD32
SFD212J•2		15	HLL36110LU	LC1D50AG7	LRD350
SFD212K•2		20	HLL36150LU	LC1D65AG7	LRD365
SFD212L•2		25	JLL36200LU	LC1D80G7	LRD3363
SFD212M•2		30	JLL36200LU	LC1D115G7	LRD4365
SFD212N•2		40	GS2MLU3N <sup>2</sup>	LC1D150G7	LR9D5369
SFD212C•3	230	1	HLL36015LU	LC1D25G7	LRD10
SFD212D•3		2	HLL36020LU	LC1D25G7	LRD12
SFD212E•3		3	HLL36025LU	LC1D25G7	LRD14
SFD212F•3		5	HLL36035LU	LC1D25G7	LRD21
SFD212G•3		7.5	HLL36060LU	LC1D32G7	LRD22
SFD212H•3		10	HLL36070LU	LC1D32G7	LRD32
SFD212J•3		15	HLL36100LU	LC1D50AG7	LRD350
SFD212K•3		20	HLL36125LU	LC1D65AG7	LRD365
SFD212L•3		25	HLL36150LU	LC1D80G7	LRD3363
SFD212M•3		30	JLL36200LU	LC1D115G7	LRD4365
SFD212N•3		40	GS2MLU3N <sup>2</sup>	LC1D150G7	LRD4367
SFD212C•4	460	1	HLL36015LU	LC1D25G7	LRD07
SFD212D•4		2	HLL36015LU	LC1D25G7	LRD08
SFD212E•4		3	HLL36015LU	LC1D25G7	LRD10
SFD212F•4		5	HLL36020LU	LC1D25G7	LRD14
SFD212G•4		7.5	HLL36025LU	LC1D25G7	LRD16
SFD212H•4		10	HLL36035LU	LC1D25G7	LRD21
SFD212J•4		15	HLL36050LU	LC1D32G7	LRD22
SFD212K•4		20	HLL36060LU	LC1D32G7	LRD32
SFD212L•4		25	HLL36080LU	LC1D50AG7	LRD340
SFD212M•4		30	HLL36100LU	LC1D50AG7	LRD340
SFD212N•4		40	HLL36125LU	LC1D65AG7	LRD365
SFD212P•4		50	GS2MLU3N <sup>2</sup>	LC1D80G7	LRD3363
SFD212Q•4		60	GS2MLU3N <sup>2</sup>	LC1D80G7	LRD3363
SFD212R•4		75	GS2MLU3N <sup>2</sup>	LC1D150G7	LRD4367
SFD212S•4		100	GS2MLU3N <sup>2</sup>	LC1D150G7	LR9D5369

<sup>1</sup> The "•" indicates the enclosure type: "A" = Type 12K and "H" = Type 3R.

<sup>2</sup> Fusible switch used for these power ratings instead of main circuit breaker.

**Table 29 – Type 1 S-Flex Bypass Circuit Control Component Renewable Parts (Mod Y Only)—All Sizes, Square D Catalog Numbers**

AFC-Off-Bypass 3-Position Selector Switch	ZB5AD3 + ZB5AZ009 + (2) ZBE203
Hand-Off-Auto 3-Position Selector Switch	ZB5AD3 + ZB5AZ009 + (4) ZBE101
AFC-Bypass 2-Position Selector Switch	ZB5AD2 + ZB5AZ009 + ZBE101 + ZBE102
Red Power On LED	80462-110-01
Green Bypass Run LED	80462-109-01

**Table 30 – Type 12K or 3R S-Flex Bypass Circuit Control Component Renewable Parts (Mod Y Only)—All Sizes, Square D Catalog Numbers**

AFC-Off-Bypass 3-Position Selector Switch	ZB5AD3 + ZB5AZ009 + (2) ZBE203
Hand-Off-Auto 3-Position Selector Switch	ZB5AD3 + ZB5AZ009 + (4) ZBE101
AFC-Bypass 2-Position Selector Switch	ZB5AD2 + ZB5AZ009 + ZBE101 + ZBE102
Red Power On LED	ZB5AVG4 + ZB5AV043
Green Bypass Run LED	ZB5AVG3 + ZB5AV033

**Table 31 – Type 12K or 3R S-Flex Fans, Filters, and Keypad**

Fan with filter, 170 mm x 150 mm, 115 Vac, 208 V, 230 V, 460 V, Type 1 and 12, Enclosures A and B	NSYCVF85M115PF
Fan with filter, 270 mm x 250 mm, 115 Vac, 208 V, 230 V, 460 V, Type 1 and 12, Enclosures C and D	NSYCVF300M115PF
Fan filter, 170 mm x 150 mm	NSYCAF125
Fan filter, 270 mm x 250 mm Enclosure grill filter, 270 mm x 250 mm	NSYCAF223
Advanced keypad	VW3A1101
Advanced keypad mounting kit	VW3A1102
Advanced keypad cover kit	VW3A1103



**S-Flex™ 212 Adjustable Speed Enclosed Drive  
Instruction Bulletin**

Schneider Electric USA, Inc.	Schneider Electric Canada, Inc.
800 Federal Street	5985 McLaughlin Road
Andover, MA 01810 USA	Mississauga, ON L5R 1B8 Canada
888-778-2733	800-565-6699
<a href="http://www.schneider-electric.us">www.schneider-electric.us</a>	<a href="http://www.schneider-electric.ca">www.schneider-electric.ca</a>

Standards, specifications, and designs may change, so please ask for confirmation that the information in this publication is current.

Schneider Electric, Altivar, Mag-Gard, Modbus, PowerPact, S-Flex, SoMove, and Square D are trademarks and the property of Schneider Electric SE, its subsidiaries, and affiliated companies. All other trademarks are the property of their respective owners.

© 2007–2018 Schneider Electric All Rights Reserved

30072-451-83 Rev. 07, 10/2018

Replaces 30072-451-83 Rev. 06, 09/2017