

SpaceLogic MP2000-NSR

Non-Spring Return Multi-Signal Actuators for VP221 SpaceLogic PIBCV, DN125-150 (5"…6")



Product Description

MP2000 NSR Actuators are for fine regulation of large control valves under the demand of the HVAC controller. MP2000 NSR Actuators can be controlled by either a modulating or a 3-point control signal and are used specifically with the VP221x SpaceLogic PIBCV valves.

Specifications

Nominal voltage	24 Vac, 50 Hz/60 Hz
Power consumption	15 VA (24 V)
Control input signal	Modulating or 3-point floating
Power Supply	24 Vac; +10 ... -15 %;
Frequency	50/60 Hz
Control input Y	0 ... 10 V (2 ... 10 V) Ri = 40 kΩ, 0 ... 20 mA (4 ... 20 mA) Ri = 500 Ω
Output (Position Feedback) U	0 ... 10 V (2 ... 10 V) 10kΩ 0...20 mA (4...20 mA) 510 Ω
Force	2000 N (450 lbf)
Stroke	50 mm (2")
Speed (selectable)	3 or 6 s/mm
Max. medium temperature	200 °C (392 °F)
Ambient temperature	0 ... + 55 °C (32...131 °F)
Storage and transport temperature	-40 ... +70 °C (-40...158 °F) (storing for 3 days)
Humidity	5...95%
Protection class	III safety extra-low voltage
Grade of enclosure	IP 54, NEMA 2
Weight	6.3 kg (13.8 lbs)
Safety function	No
Manual operation	Electrical and Mechanical
Power failure response MP2000-NSR	Non-spring return

Features

- Manual operation mechanical and/or electrical
- Position indication, LED signalization
- Selectable speed 3 or 6 s/mm
- Automatic Stroke Calibration
- Integrated external switch
- Linear to EQ% Curve Adaptation
- Anti-oscillation function
- Voltage or current output signal U
- External reset button
- Auto detection of Y signal
- Floating or modulating control selection
- Thermal and overload protection
- Precise regulation and fast response on floating signal (0.01 s)

CE marking in accordance with the standards	Low Voltage Directive 2006/95 EEC EMC Directive 2004/108 EEC cULus according to UL 60730-1A/-2-14 and CAN/CSA E60730-1/-2-14 and CE according to EN 60730-1/-2-14 per EMC [2014/30/EU] and LVD [2014/35/EU]
---	---

Part Numbers

Part No.	Spring Return Direction
MP2000-NSR	Non-Spring Return

Dimensions mm (inch)

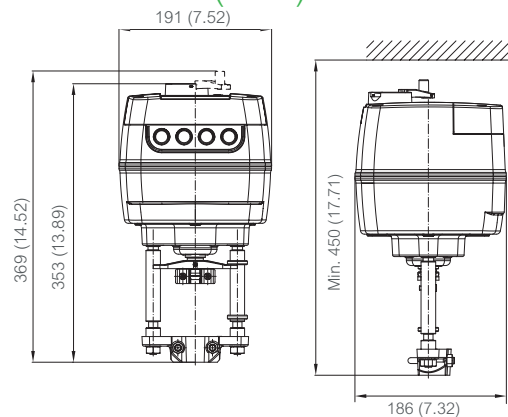

Mounting and Installation

The actuator should be mounted with the valve stem in either horizontal position or pointing upwards. Use a 4 mm Allen key (not supplied) to fit the actuator to the valve body. Allow for necessary clearance for maintenance purposes. The valve has position indication rings which should be pushed together before commissioning; after stroking they indicate the ends of the stroke.

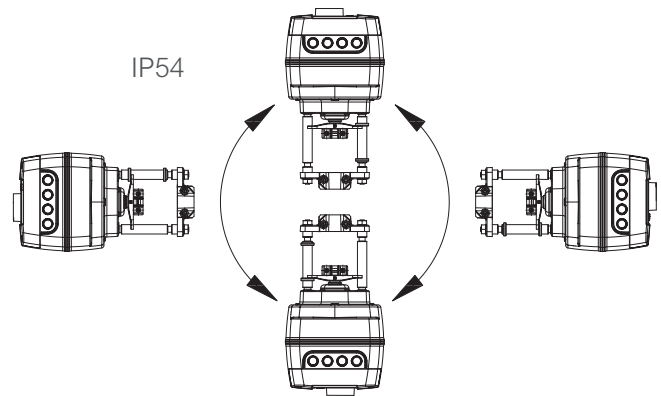

Design

1. Manual operation knob
2. Function buttons
3. Service cover
4. Removable gland support
5. Position indication ring
6. Stem connector
7. Valve connector

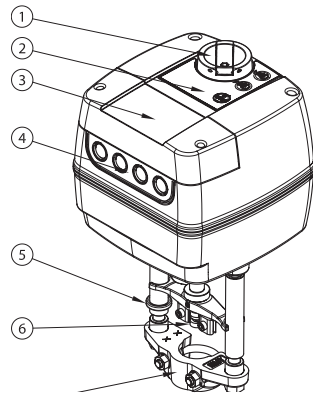



Manual & Electrical Operation

NOTE: Mechanical manual operation is only allowed when there is no power to the actuator. Actuators can be manually positioned when in Stand-By mode or when there is no power supply (mechanically).

Mechanical Manual Operation

(Fig. A) MP2000-NSR have a knob on the top of the housing enabling manual positioning of the actuator.

Electrical manual operation

(Fig. B) MP2000-NSR have two buttons on the top of the housing for electrical manual positioning (up or down) if the actuator is in Stand-By mode. First press the RESET button until the actuator goes to Stand-By mode (red LED is lit). By pressing the upper button  the stem will be extracted and by pressing the lower button  the stem will be retracted.

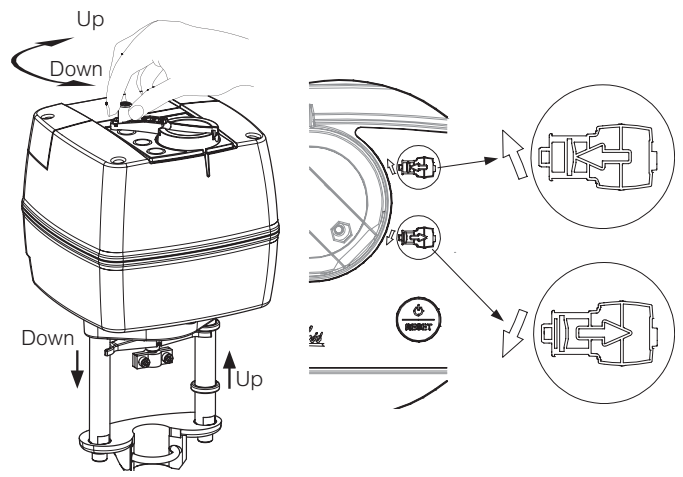
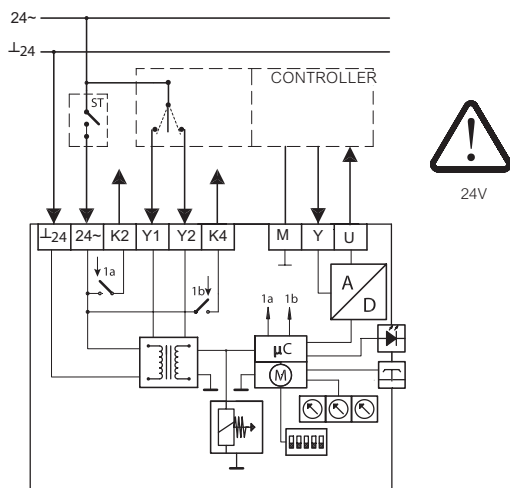

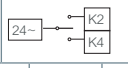

Fig. A

Fig. B

Wiring and Connections

Electrical connections can be accessed by removing the service cover. Four cable/conduit entries are provided for two M 16×1.5 and M 20×1.5 (1/2") cable/conduit entries. Note that in order to maintain the enclosure IP rating, appropriate cable glands must be used. **NOTE:** Do not touch anything on the PCB. Do not remove the service cover before the power supply is fully switched off. Maximum allowed current output on terminals K2 and K4 is 4A. Minimum power is 3W.



L24	SN	0 V		Neutral
24~	SP	24 V AC		Power supply
K2, K4	4, 5	24~(AC)		24~ output -max 4A -min 3W
Y1	1	24~		Input
Y2	3			
M	GND	0 V		Neutral
Y	Y	0(2)-10 V 0(4)-20 mA		Input
U	X	0(2)-10 V 0(4)-20 mA		Output

LED Signalling

LED	Indication type	Operating mode
Green LED		Constantly lit Positioning mode - Actuator is retracting the stem
		Constantly lit Positioning mode - Actuator is extracting the stem
		Flashing (1 s cycle) Self stroking mode - Actuator is retracting the stem
		Flashing (1 s cycle) Self stroking mode - Actuator is extracting the stem
Yellow LED		Constantly lit Stationary mode - Actuator has reached upper end position (retracted stem)
		Constantly lit Stationary mode - Actuator has reached bottom end position (extracted stem)
		Flashing Stationary mode - Single blink when Y signal is presents and double blinks when Y signal is not connected)
Red LED		Constantly lit Stand-By mode
		Flashing Error Mode
Red/ Yellow LED		Flashing (1 s cycle) Set up stroke limitation (retracted stem)
		Flashing (1 s cycle) Set up stroke limitation (extracted stem)
Dark	No indication	No power supply

Actuator Operating Modes

LED operating mode indicator

The three-color (green/yellow/red) LED function indicators are located on the actuator cover. They indicate different operating modes.

RESET button

MP2000-NSR Actuators have an external RESET button is located on the top cover next to the LED indicators. Pressing this button enables entering or exiting Stand-By mode (press once) or Self stroking mode (press and hold for 5 seconds).

Operating modes

- Self stroking mode: Self stroking mode starts automatically the first time when power supply is applied to the actuator. To start self stroking procedure press and hold RESET button for 5 seconds until the green light starts flashing. End positions of the valve are automatically set and the actuator goes to stationary mode and starts responding to the control signal.

- Stand-By mode: Press the RESET button for 1 sec. to enter Stand-By mode. The actuator stops in current position and stops responding to any control signal. Red light is constantly lit. You can manually operate the actuator with mechanical handle or control buttons. This mode can be very useful during the commissioning of other equipment, or for service purposes. In this mode you can also set positions of the additional switches. To exit Stand-By mode press the RESET button again.
- Positioning mode: The actuator is operating automatically. The stem is extracting or retracting according to the control signal. When positioning is finished the actuator goes to stationary mode. If for one or another reason floating signal (terminal Y1 and Y3) and Y signal would be present at the same time, floating signal would prevail.
- Stationary mode: The actuator is operating without errors.
- Error mode: Working temperature is too high - check the ambient temperature.
- Stroke is too short: Check the connection with valve and valve operation, or check if valve is blocked.

DIP Switch Settings

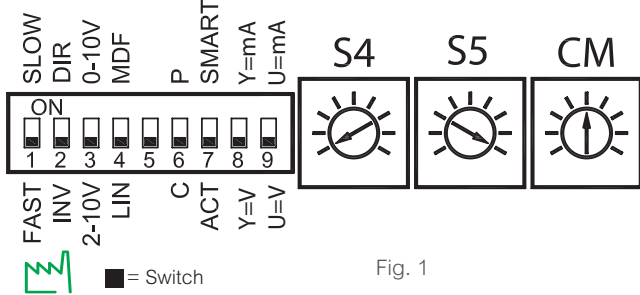

Fig. 1

The actuator has a selection of DIP switches (Fig. 1) under the service cover. Factory delivery, all switches are OFF.

- **SW1: FAST/SLOW – Speed selection**
 - OFF position: Fast, 3 s/mm
 - ON position: Slow; 6 s/mm
- **SW2: DIR/INV – Direct or inverse acting (Fig. 2):**
 - ON position: DIR; the actuator is direct acting to input signal
 - Off position: INV; the actuator is inverse acting to control signal
- **SW3: 2-10 V/0-10 V – Input/output**
 - OFF position: 2-10 V; for input signal in the range from 2-10 V (voltage input) or from 4-20 mA (current input)
 - ON position: 0-10 V; for input signal in the range from 0-10 V (voltage input) or from 0-20 mA (current input)
 - Signal range sets Y and X signal.
- **SW4: LIN/EQ% – Flow curve adaptation (Fig. 3):**
 - OFF position: LIN; Linear correlation between Y signal and stem position
 - ON position: EQ%; modified correlation between Y signal and stem position for EQ flow in the valve. Degree of modification depends on setting of potentiometer CM but normally set at max position.
 - Enables changing flow characteristic linear to logarithmic and works in all combinations of DIP switch settings.
- **SW5: 100%/95% – Stroke limitation:**
 - Remains in OFF position; do not use.
- **SW6: C/P – Output signal mode (Fig. 4.):**
 - An output signal is present on terminal K2 when the position of the actuator is equal to or lower than the S4 set point. An output signal is present on terminal K4 when the position of the actuator is equal to or higher than the S5 set point.
 - OFF position: C, provides a constant output signal on terminals K2 or K4, regardless of the input signal.
 - ON position: P, provides a pulse signal through parallel or cascade electrical wiring input Y1 and Y2 depends from the controller to output terminals K2 and K4.
- **SW7: Smart function:**
 - OFF position; the actuator does not try to detect oscillations in the system
 - ON position; actuator enables special anti-oscillation algorithm – see Anti-Oscillation Algorithm
- **SW8: V/mA Input signal type:**
 - OFF position: V; input signal Y is set to voltage (V)
 - ON position: mA; input signal Y is set to current (mA)

NOTE: Y detection is disabled if SW8 is set to ON position and SW3 is set to OFF position.

- **SW9: V/mA: Position feedback signal type**
 - OFF position: V; output signal X is set to voltage (V)
 - ON position: mA; output signal X is set to current (mA)

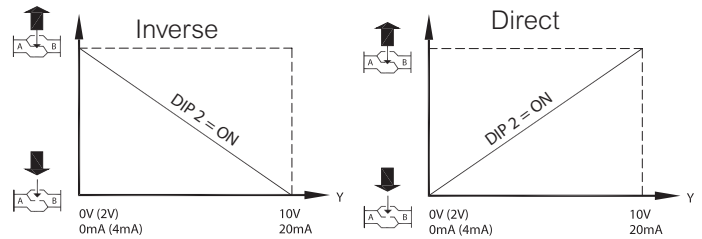

Fig. 2

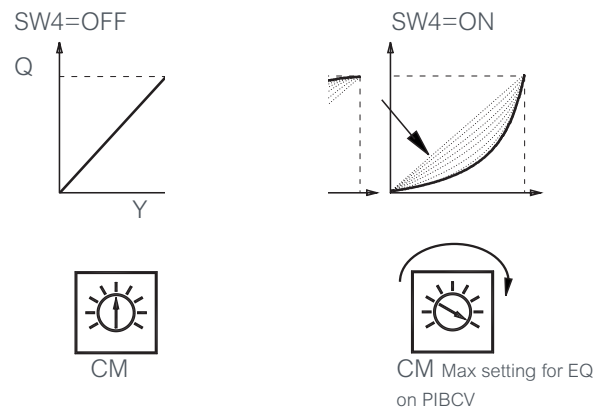

Fig. 3

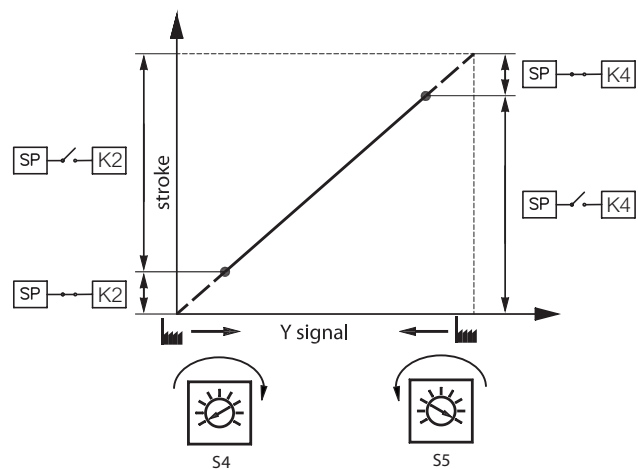

Fig. 4

Anti-Oscillations Algorithm

(SW 7 in position ON)

The actuator has special anti oscillations algorithm. In case control signal Y on certain point oscillates (Fig. 5) - looking from time perspective, algorithm starts to lower the amplification of the output to the valve. Instead of having static characteristics actuator changes to dynamic characteristics. After control signal does not oscillate anymore output to the valve slowly returns back to static characteristics.

Oscillation

(Fig. 6) Harmonic oscillations are high frequency oscillations with low amplitude that vary around its own equilibrium value and not around set-point temperature. They can appear in up to 70 % of control time, even though the system is properly commissioned. Harmonic oscillations have negative influence on control stability, and lifetime of the valve and actuator.

Smoothing function

The Smoothing function reduces harmonic oscillations; consequently room temperature is closer to the set-point (desired) temperature. Smoother operation of the MCV increases lifetime of the valve and actuator and saves energy and reduces costs in general.

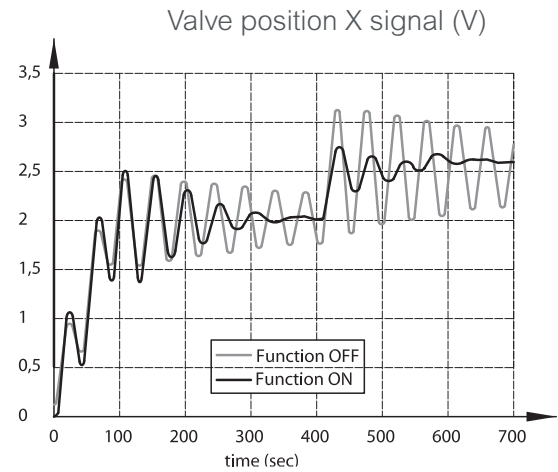

Fig. 5

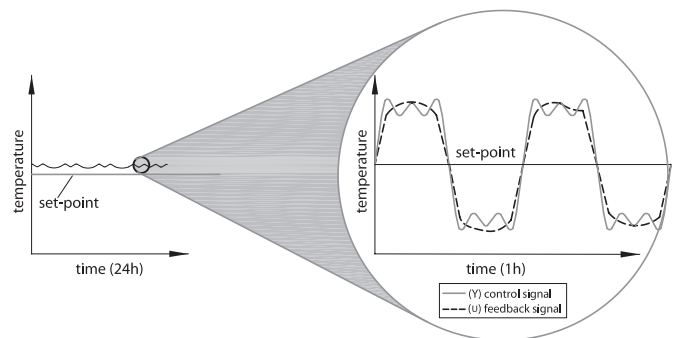

Fig. 6

