

BCPM Series Panelboard Monitoring Systems

BCPM

User Guide

Branch Circuit Power Meter

Z205396-0K

08/2016

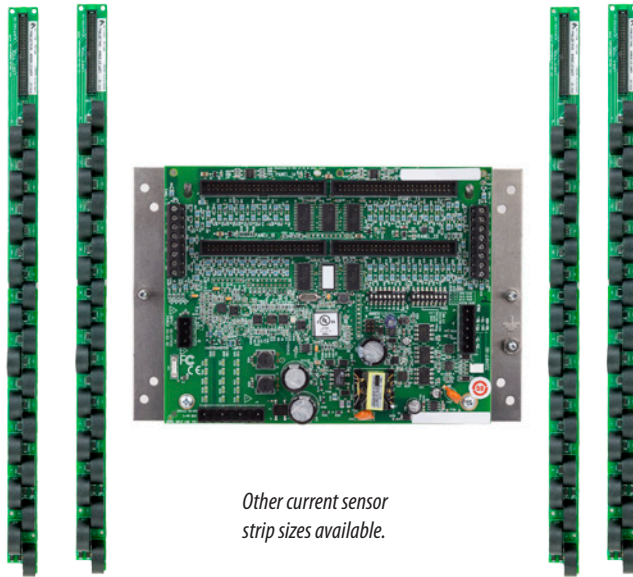

*Other current sensor
strip sizes available.*



Safety Information

Important information

Read these instructions carefully and look at the equipment to become familiar with the device before trying to install, operate, service or maintain it. The following special messages may appear throughout this bulletin or on the equipment to warn of potential hazards or to call attention to information that clarifies or simplifies a procedure.



The addition of either symbol to a “Danger” or “Warning” safety label indicates that an electrical hazard exists which will result in personal injury if the instructions are not followed.

This is the safety alert symbol. It is used to alert you to potential personal injury hazards. Obey all safety messages that follow this symbol to avoid possible injury or death.

⚠ DANGER

DANGER indicates a hazardous situation which, if not avoided, **will result in** death or serious injury.

⚠ WARNING

WARNING indicates a hazardous situation which, if not avoided, **could result in** death or serious injury.



⚠ CAUTION

CAUTION indicates a hazardous situation which, if not avoided, **could result in** minor or moderate injury.

NOTICE

Notice is used to address practices not related to physical injury.

Safety Precautions

  **DANGER**

HAZARD OF ELECTRIC SHOCK, EXPLOSION, OR ARC FLASH

- Follow safe electrical work practices. See NFPA 70E in the USA, CSA Z462 in Canada, or applicable local codes.
- Read and understand the instructions before installing the product. Follow the instructions during installation.
- Installation, wiring, testing or service must be performed only by qualified persons in accordance with all applicable codes and regulations.
- Install the product in an appropriate electrical and fire enclosure per local regulations.
- Do not use the product for life or safety applications.
- Do not install the product in hazardous or classified locations.
- Do not exceed the product's ratings or maximum limits.
- The product may use multiple voltage/power sources.
- Turn off ALL power supplying equipment before working on or inside the equipment.
- Use a properly rated voltage sensing device to confirm that all power is off.
- Do NOT depend on the product for voltage indication.
- Products rated only for basic insulation must be installed on insulated conductors.
- Current transformer secondaries (current mode) must be shorted or connected to a burden at all times.
- Remove all wire scraps and tools, replace all doors, covers and protective devices before powering the equipment.

Failure to follow these instructions will result in death or serious injury.

A qualified person is one who has skills and knowledge related to the construction and operation of this electrical equipment and installations, and has received safety training to recognize and avoid the hazards involved. NEC Article 100

If this product is used in a manner not specified by the manufacturer, the protection provided by the product may be impaired. No responsibility is assumed by Schneider Electric for any consequences arising out of the use of this material.

Control system design must consider the potential failure modes of control paths and, for certain critical control functions, provide a means to achieve a safe state during and after a path failure. Examples of critical control functions are emergency stop and over-travel stop.

WARNING

LOSS OF CONTROL

- Assure that the system will reach a safe state during and after a control path failure.
- Separate or redundant control paths must be provided for critical control functions.
- Test the effect of transmission delays or failures of communication links.¹
- Each implementation of equipment using communication links must be individually and thoroughly tested for proper operation before placing it in service.

Failure to follow these instructions may cause injury, death or equipment damage.

¹For additional information about anticipated transmission delays or failures of the link, refer to NEMA ICS 1.1 (latest edition). Safety Guidelines for the Application, Installation, and Maintenance of Solid-State Controls or its equivalent in your specific country, language, and/or location.

Provide a disconnect device to disconnect the meter from the supply source. Place this device in close proximity to the equipment and within easy reach of the operator, and mark it as the disconnecting device. The disconnecting device shall meet the relevant requirements of IEC 60947-1 and IEC 60947-3 and shall be suitable for the application. In the US and Canada, disconnecting fuse holders can be used. Provide overcurrent protection and disconnecting device for supply conductors with approved current limiting devices suitable for protecting the wiring.

For use in a Pollution Degree 2 or better environment only. A Pollution Degree 2 environment must control conductive pollution and the possibility of condensation or high humidity. Consider the enclosure, the correct use of ventilation, thermal properties of the equipment, and the relationship with the environment.

FCC Notice

FCC PART 15 INFORMATION

NOTE: This equipment has been tested by the manufacturer and found to comply with the limits for a class B digital device, pursuant to part 15 of the FCC Rules. These limits are designed to provide reasonable protection against harmful interference when the equipment is operated in a residential environment. This equipment generates, uses, and can radiate radio frequency energy and, if not installed and used in accordance with the instruction manual, may cause harmful interference to radio communications. This device complies with part 15 of the FCC Rules. Operation is subject to the following two conditions:

- (1) This device may not cause harmful interference, and
- (2) this device must accept any interference received, including interference that may cause undesired operation.

Modifications to this product without the express authorization of the manufacturer nullify this statement.

Contents

Specifications.....	1
Introduction.....	2
Part Number Information	3
Parts of the BCPM.....	4
Dimensions.....	5
Data Output	7
LED Blink Codes.....	9
Solid-Core Current Sensor Accuracy.....	10
Installation.....	10
Wiring.....	15
Configuration	18
Default DIP Switch Settings.....	20
Communications Setup.....	21
Commissioning	22
Recommended Accessories	23
Troubleshooting	23
China RoHS Compliance Information.....	24
EAC Compliance Information	25
Appendix: Panel Configuration Diagrams and Selection Matrix	26

Specifications

Table 1: Specifications

Type	Description
Voltage Inputs	
Measurement Voltage	90 to 300 Vac line-to-neutral, 50/60 Hz
Control Power	90 to 277 Vac line-to-neutral
Frequency	50/60 Hz
Accuracy	
Power/Energy	IEC 62053-21 Class 1, ANSI C12.1-2008 system accuracy (including branch CTs)
Voltage	±0.5% of reading 90 to 277 V line-to-neutral
Current	±0.5% of reading
Minimum ON Current	50 mA
Operation	
Sampling Frequency	2560 Hz
Update Rate	1.8 seconds (both panels)
Outputs	
Type	Modbus™ RTU
Connection	DIP switch-selectable 2-wire or 4-wire, RS-485
Address	DIP switch-selectable address 1 to 247 (in pairs of 2)*
Baud Rate	DIP switch-selectable 9600, 19200, 38400
Parity	DIP switch-selectable NONE, ODD, EVEN
Communication Format	8 data bits, 1 start bit, 1 stop bit
Termination	5-position depluggable connector (TX+ TX- SHIELD TX+/RX+ TX-/RX-)
Wire Size Range	
Aux CT Terminals on Main Board	24 to 14 AWG
Removable Connectors on Main Board	22 to 12 AWG
Terminal Block Torque	
Aux CT Terminals on Main Board	3.5 to 4.4 in-lb (0.4 to 0.5 N-m)
Removable Connectors on Main Board	4.4 to 5.3 in-lb (0.5 to 0.6 N-m)
Mechanical	
Ribbon Cable Support	4 ft. (1.2 m) round cable ships standard; up to 20 ft. (6 m) ribbon cables are available
Environmental	
Operating Temperature Range	0 to 60 °C (32 to 122 °F) (<95% RH, non-condensing)
Storage Temperature Range	-40 to 70 °C (-40 to 158 °F)
Altitude of Operation	3000 m (9843 ft)
Compliance Information	
Agency Approvals	UL508 open type device**, IEC/EN61010-1
Installation Category	Cat III, pollution degree 2
Conducted and Radiated Emissions	FCC part 15 Class B, EN55011/EN61000-6-3 Class B (residential and light industrial)
Conducted and Radiated Immunity	EN 61000-6-2 and EN 61326-1

* See Configuration section for details.

** BCPM internal circuitry (cables and CTs) are not circuits as defined by UL508A, as they do not extend beyond the BCPM itself without further safety/fire isolation.



Note: The CE mark indicates RoHS2 compliance. Please refer to the CE Declaration of Conformity for additional details.

Introduction

The PowerLogic™ Branch Circuit Power Meter is a device designed to measure the current, and on some models voltage, and energy consumption of up to 92 circuits (84 branch circuits, two three-phase mains, two neutrals) on a single board. It increases the board's current monitoring capability by combining the functions of two boards into one device.

The BCPM consists of a data acquisition board and up to four 21-unit current sensor strips and eight auxiliary inputs. The strips are mounted on each side of the panel board along the termination points of each breaker. The conductor passes through the appropriate current sensor before terminating at the breaker. Each strip transmits the current data to the data acquisition board. The auxiliary inputs can be used with voltage-output CTs (sold separately) to monitor the main feed to the panel being monitored (not for use with higher-voltage circuits). The BCPM can easily accommodate different panel configurations, including any combination of multi-phase breaker positions, voltage phase mapping, and breaker sizes. To configure the BCPM for operation, use the Schneider Electric ION Setup configuration software tool. Get the latest version at <https://schneider-electric.box.com/ionsetuplatest>.

Data is transmitted over an RS-485 Modbus protocol. Each data acquisition board requires two addresses, one for each set of two current sensor strips and four auxiliary inputs. Data is updated roughly every two seconds. As a circuit approaches the user-defined threshold, the BCPM activates the event indicators.

The BCPM is available in three model types. The BCPMA measures both current and power in the mains and branch circuits. The BCPMB measures power in the mains and current only in the branch circuits. The BCPMC measures current in the mains and branch circuits only.

Part Number Information

Part Number	Description
BCPMA084S	BCPM Advanced feature set, 84 solid core 100 A CTs, 19 mm CT spacing
BCPMA184S	BCPM Advanced feature set, 84 solid core 100 A CTs, 26 mm CT spacing
BCPMA042S	BCPM Advanced feature set, 42 solid core 100 A CTs, 19 mm CT spacing
BCPMA142S	BCPM Advanced feature set, 42 solid core 100 A CTs, 26 mm CT spacing
BCPMB084S	BCPM Intermediate feature set, 84 solid core 100 A CTs, 19 mm CT spacing
BCPMA224S	BCPM Advanced feature set, 24 solid core 100 A CTs (2 strips), 18 mm CT spacing
BCPMA236S	BCPM Advanced feature set, 36 solid core 100 A CTs (2 strips), 18 mm CT spacing
BCPMA242S	BCPM Advanced feature set, 42 solid core 100 A CTs (2 strips), 18 mm CT spacing
BCPMA248S	BCPM Advanced feature set, 48 solid core 100 A CTs (4 strips), 18 mm CT spacing
BCPMA272S	BCPM Advanced feature set, 72 solid core 100 A CTs (4 strips), 18 mm CT spacing
BCPMA284S	BCPM Advanced feature set, 84 solid core 100 A CTs (4 strips), 18 mm CT spacing
BCPMB184S	BCPM Intermediate feature set, 84 solid core 100 A CTs, 26 mm CT spacing
BCPMB042S	BCPM Intermediate feature set, 42 solid core 100 A CTs, 19 mm CT spacing
BCPMB142S	BCPM Intermediate feature set, 42 solid core 100 A CTs, 26 mm CT spacing
BCPMC084S	BCPM Basic feature set, 84 solid core 100 A CTs, 19 mm CT spacing
BCPMB224S	BCPM Intermediate feature set, 24 solid core 100 A CTs (2 strips), 18 mm CT spacing
BCPMB236S	BCPM Intermediate feature set, 36 solid core 100 A CTs (2 strips), 18 mm CT spacing
BCPMB242S	BCPM Intermediate feature set, 42 solid core 100 A CTs (2 strips), 18 mm CT spacing
BCPMB248S	BCPM Intermediate feature set, 48 solid core 100 A CTs (4 strips), 18 mm CT spacing
BCPMB272S	BCPM Intermediate feature set, 72 solid core 100 A CTs (4 strips), 18 mm CT spacing
BCPMB284S	BCPM Intermediate feature set, 84 solid core 100 A CTs (4 strips), 18 mm CT spacing
BCPMC184S	BCPM Basic feature set, 84 solid core 100 A CTs, 26 mm CT spacing
BCPMC042S	BCPM Basic feature set, 42 solid core 100 A CTs, 19 mm CT spacing
BCPMC142S	BCPM Basic feature set, 42 solid core 100 A CTs, 26 mm CT spacing
BCPMC224S	BCPM Basic feature set, 24 solid core 100 A CTs (2 strips), 18 mm CT spacing
BCPMC236S	BCPM Basic feature set, 36 solid core 100 A CTs (2 strips), 18 mm CT spacing
BCPMC242S	BCPM Basic feature set, 42 solid core 100 A CTs (2 strips), 18 mm CT spacing
BCPMC248S	BCPM Basic feature set, 48 solid core 100 A CTs (4 strips), 18 mm CT spacing
BCPMC272S	BCPM Basic feature set, 72 solid core 100 A CTs (4 strips), 18 mm CT spacing
BCPMC284S	BCPM Basic feature set, 84 solid core 100 A CTs (4 strips), 18 mm CT spacing

Parts of the BCPM

Figure 2 shows the parts of the BCPM, while Table 2 describes these parts.

Figure 1 BCPM Panel Board Monitoring System

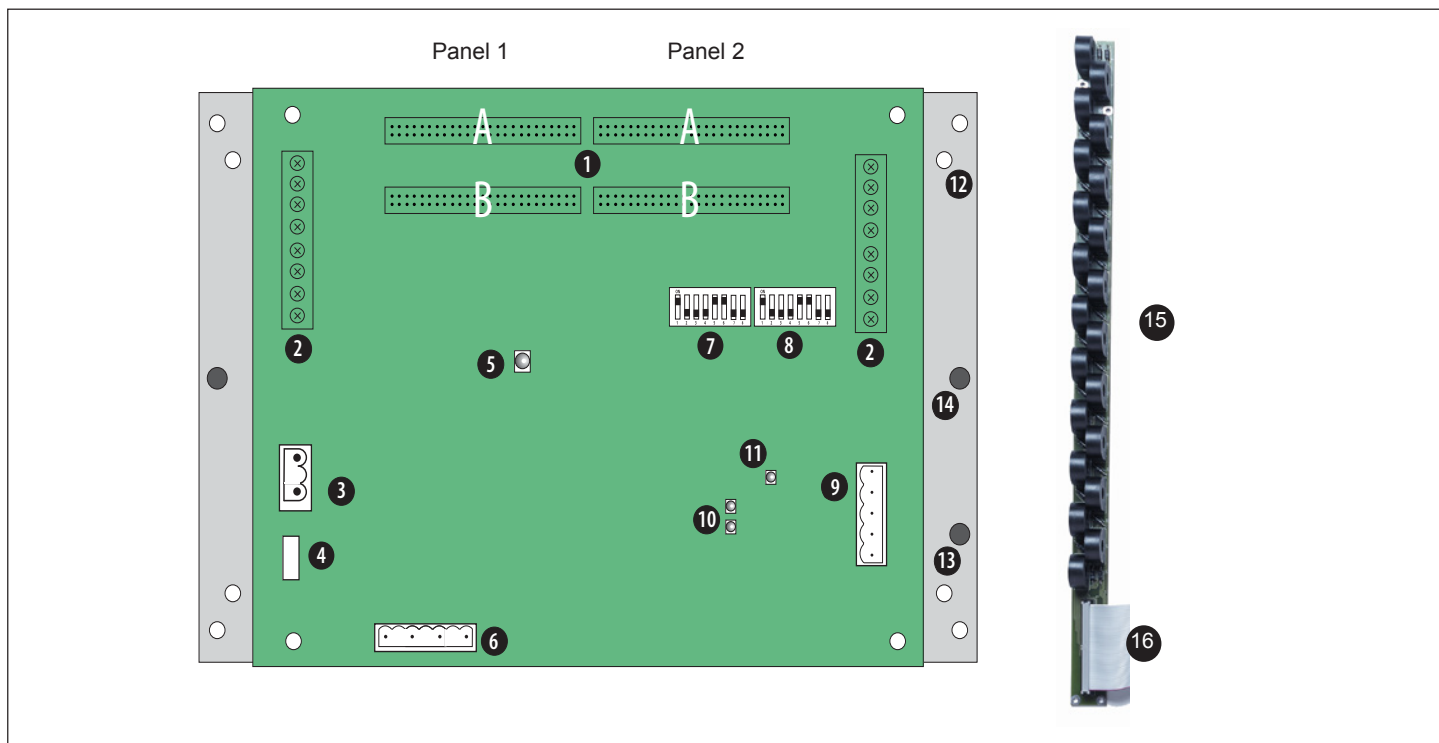

Table 2: Part Description of the BCPM

Part	Description
1	50-Pin Ribbon Cable Connectors (Data Acquisition Board) 48-inch (1220 mm) ribbon cables are provided for easy snap connection of current sensor strips to this point of the data acquisition board. The two connectors on the left are for Panelboard 1; the two on the right are for Panelboard 2. Note: Connect current sensor strips to the correct ribbon cable connectors for each panel. The top connector is for Strip A, and the bottom connector is for Strip B. Note: Verify that the serial numbers on the current sensor strips match the serial number on the data acquisition board.
2	Auxiliary CT Inputs These 0.333 Vac inputs are used for monitoring the main breaker or other high amperage source. Inputs on the left are for Panelboard 1; inputs on the right are for Panelboard 2.
3	Control Power Connection Provides power to operate the meter.
4	Control Power Fuse 600 Vac, 500 mA time lag, factory-replaceable.
5	"Alive" LED Red/green/amber LED. See Table 4 for LED blink codes.
6	Voltage Taps 1, 2, or 3 phase plus neutral connections. For voltage sensing and power calculations. Voltage connectors on models BCPMA and BCPMB only.
7	Communications Address DIP Switches Each Modbus [®] device must have a unique address. Switches are binary weighted. Left-most switch has a value of 1; right-most switch has a value of 128. The 4-strip model uses two addresses.
8	Communications Settings DIP Switch Configures baud rate, parity, 2- or 4-wire communications.
9	RS-485 Connection Used for Modbus [®] serial communications. The Universal plug accommodates 2- or 4-wire connections.
10	RS-485 LEDs The RX LED (closest to DIP switches) indicates the RS-485 is receiving information; the TX LED indicates transmission of information.
11	Power LED Indicates power to main board.
12	Mounting holes For mounting the BCPM main board.
13	Ground lug For connecting the BCPM to Earth ground.
14	Screw studs For mounting the optional BCPMCOVERS plexiglas cover.
15	Current Sensors For monitoring branch current.
16	50 Pin Ribbon Cable Connectors (CT Strips) Connects current signal from the current sensor strip to the main board via the ribbon connectors.

Dimensions

Figure 2 Data Acquisition Board and Mounting Bracket

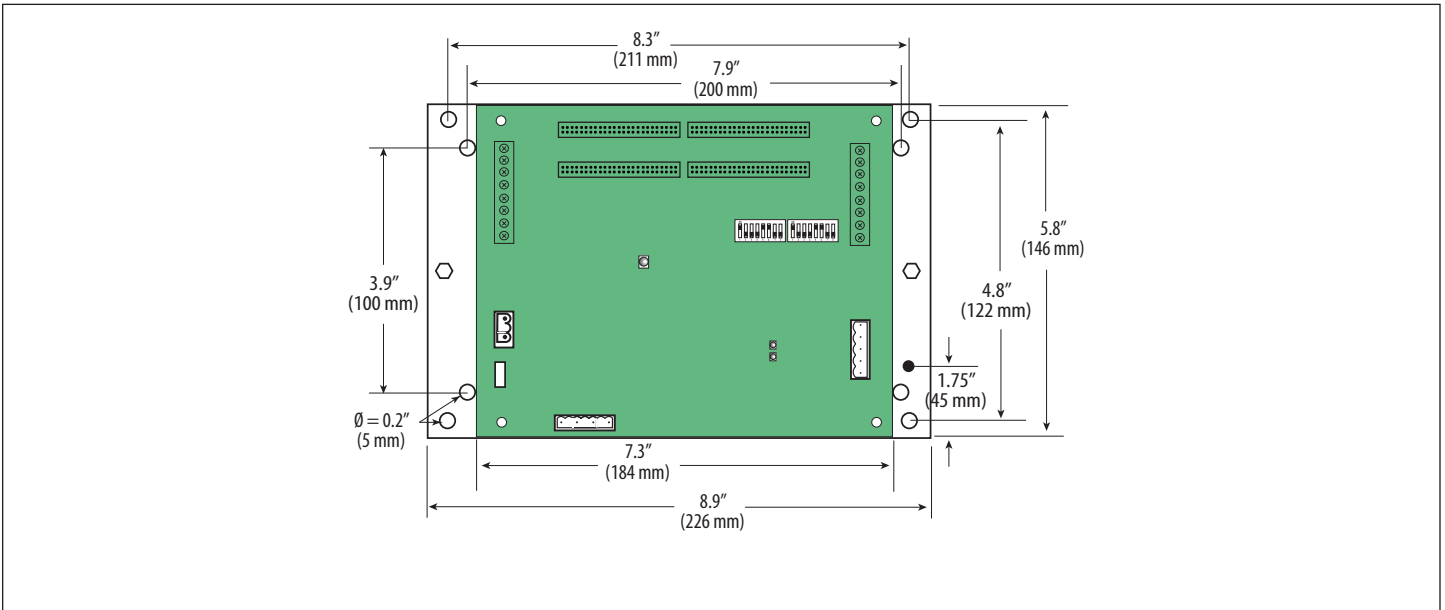
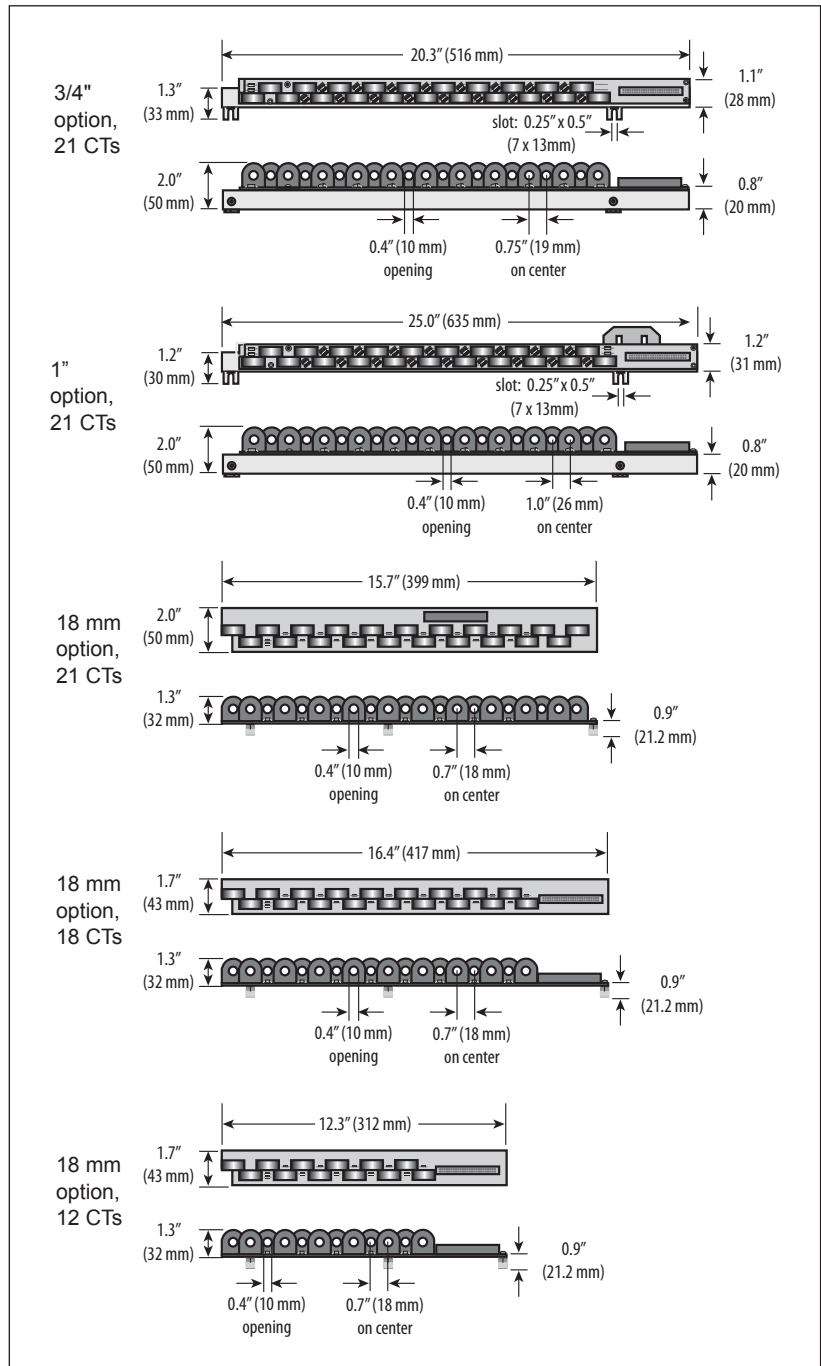

Figure 3 Current Sensor Strips



Data Output

The BCPM provides several types of measurements that give a comprehensive view of power consumption for every load on the panel (the table below shows which measurements are offered on each model):

- Real-time measurements: A live and up-to-date view of present power levels and the factors that affect them.
- Demand measurements: Averages of values measured over a specified time interval. The time interval (typically 15 minutes) can be set from 10 seconds to more than a day. The demand calculation can be configured to use single intervals or the sliding average of up to six sub-intervals. Demand measurements are useful for tracking or graphing load levels over time to correlate with total energy consumption.
- Historic maximum measurements: These measurements store the largest value recorded for a specific measurement since the last time they were cleared. They are useful for identifying peak levels critical to equipment sizing or demand limits in utility agreements.
- Accumulated energy measurements: Ongoing totals of cumulative energy used since the last time the value was cleared. Energy values provide the informational basis for billing, cost allocation, carbon offset, BTU equivalent calculations, and other applications of overall energy use.
- Energy snapshots: Energy totals that only change when the demand intervals are updated. They are samples of the free-running energy accumulators at the end of each demand interval, as configured by the user. These provide energy readings that are easily correlated to the demand values to simplify the tasks of sub-billing and cost allocation.
- Over-threshold Events (previously referred to as Alarms): Provide a warning of excessively high or low current on each branch and aux channel. The user can set two high-level and two low-level thresholds, and a delay time for latching events. Events are reported as both non-latched events and latched events. Non-latching events are active while the current exceeds the threshold, but go inactive if the current returns to a level within the specific thresholds. Latching events become active when the current or voltage exceeds the threshold for a time period greater than the specified delay and remain active until they are cleared remotely.
- Event status can be polled via Modbus.

Advanced Features - Some models, especially the BCPMA support a number of advanced features. Some are always active, and others are configured manually via Modbus register 62017). For models with 42 channels or more, these features are configured independently for each panel.

- Logical meter support: The BCPM can be configured to map any set of 1, 2 or 3 channels that are adjacent in the panel to a logical meter, referred to in the point map as a logical circuit, that provides accurate multi-phase measurement totals. Map these logical circuits by writing the desired logical circuit number into a set of registers/data objects provided for each branch and aux channel (per panel).
- The channels assigned to each logical circuit must be adjacent in the panel (usually used for multi-phase breakers), but there are no limitations on where those adjacent channels are aligned in the panel (any position where a multi-phase breaker can be installed). This functionality is always active, but a user selection affects the how the data can be accessed via Modbus. Measurement data via Modbus for logical circuits is presented in two ways, arranged either by logical circuit number (looks more like a collection of individual meters) or by measurement type (arranged similar to the single-phase data section of the point map).
- Legacy point map or alternate logical circuit point map: The BCPM can be configured to select a preferred version of the Modbus registers

in the address range 4000 to 9999. If enabled (default), the logical circuits by measurement type is active. Otherwise, the legacy point maps for 2-phase and 3-phase breakers used in BCPM models with a firmware version earlier than 1.023 is active. The logical circuits functionality can also be accessed via the “Logical Circuits by Circuit” section of the point map (address range 10000 to 45000), regardless of the state of this selection.

- Phase angle measurements: The BCPM measures the phase angle of every voltage and current input and presents these measurements (in degrees) in additional data registers/objects. These values are used to verify that current inputs are assigned to the proper voltage phases and to help determine how power factor variations are influenced by current phase changes vs. harmonic distortion. Phase angle measurements are instantaneous and always active.
- User CT phase assignment: In the default mode, the BCPM assigns each channel to the corresponding phase that most 3-phase panels implement, so that the user does not have worry about it. The user can opt to replace this self-assignment paradigm with a mode that allows explicit specification of the phase assignment for each channel. The explicit assignments set by the user are stored by the BCPM in non-volatile memory.
- Phase angle reference: The BCPM measures the phase angle of every current and voltage input. The user can select whether the phase angles are stated relative to an absolute reference (the phase angle of voltage input V1) or relative to the voltage phase assigned to that specific current input channel.
- Demand/snapshot time interval source: The BCPM offers two mechanisms for driving the demand/snapshot time interval, an interval timer or an RTC (real-time clock). The legacy mode (default) uses an interval timer that does not need to be set to an absolute time. When using the interval timer the demand/snapshot interval can be set from 10 to 32767 seconds (over 9 hours). An alternate mode utilizes an RTC set to a specific date and time to synchronize the results with a larger system. The RTC must first be set in order to run and capture demand values and energy snapshots. When power is interrupted, the RTC resets to a default date and time and must be set again in order to run. When using the RTC, the demand/snapshot interval can be set from 10 to 3600 seconds (1 hour).

Table 3: Data Output

		BCPMA	BCPMB	BCPMC
Monitoring of Mains				
Real Time Measurements	Current: multi-phase average and per phase	•	•	•
	Current phase angle	•	•	
	Real power (kW): multi-phase total and per phase	•	•	
	Apparent power (kVA): multi-phase total and per phase	•	•	
	Power factor: multi-phase average and per phase	•	•	
	Voltage - L-L: multi-phase average and per phase	•	•	
	Voltage - L-N: multi-phase average and per phase	•	•	
	Frequency (phase A)	•	•	
Demand Measurements	Current present demand: multi-phase average and per phase	•	•	•
	Real Power (kW) present demand: multi-phase average and per phase	•	•	
Historic Maximums	Maximum instantaneous current: multi-phase average and per phase	•	•	•
	Maximum current demand: multi-phase average and per phase	•	•	•
	Maximum real power demand: multi-phase total and per phase	•	•	
Accumulated Energy	Energy (kWh): multi-phase total and per phase	•	•	
Energy Snapshots	Energy (kWh): multi-phase total and per phase	•	•	
Monitoring of Branch Circuits				
Real Time Measurements	Current: multi-phase average and per phase	•	•	•
	Current phase angle per branch	•		
	Real power (kW): multi-phase total and per phase	•		
	Apparent power (kVA): multi-phase total and per phase	•		
	Power factor: multi-phase average and per phase	•		
Demand Measurements	Current present demand: multi-phase average and per phase	•	•	•
	Real power (kW) present demand: multi-phase average and per phase	•		
Historic Maximums	Maximum instantaneous current: multi-phase average and per phase	•	•	•
	Maximum current demand: multi-phase average and per phase	•	•	•
	Maximum real power demand: multi-phase total and per phase	•		
Accumulated Energy	Energy (kWh): multi-phase total and per phase	•		
Energy Snapshots	Energy (kWh): multi-phase total and per phase	•		
Modbus Events				
Events	Voltage over/under	•	•	
	Branch current over/under	•	•	•
	Mains current over/under	•	•	

LED Blink Codes

Table 4: LED Blink Codes

Color and Pattern	Status Description
Green, once per second	Normal operation
Amber, once per second	Volts or Amps clipping
Amber, twice per second	Invalid firmware image
Amber, three per second	Incorrect strips or strip order*
Red, solid or blink	Diagnostic event detected

* Units with firmware V1.023 or newer do not report this message.



Solid Core Current Sensor Accuracy

Table 5: CT Specifications

	100 A Solid-Core CT
Voltage Rating	300 Vac
Measurement Range	120 A*
Temperature	0 to 60 °C
Agency	UL508 recognized, EN61010

* Momentary.

Installation



DANGER

HAZARD OF ELECTRIC SHOCK, EXPLOSION, OR ARC FLASH

- Follow safe electrical work practices. See NFPA 70E in the USA, CSA Z462 in Canada, or applicable local codes.
- Read and understand the instructions before installing the product. Follow the instructions during installation.
- Installation, wiring, testing or service must be performed only by qualified persons in accordance with all applicable codes and regulations.
- Install the product in an appropriate electrical and fire enclosure per local regulations.
- Do not use the product for life or safety applications.
- Do not install the product in hazardous or classified locations.
- Do not exceed the product's ratings or maximum limits.
- The product may use multiple voltage/power sources.
- Turn off ALL power supplying equipment before working on or inside the equipment.
- Use a properly rated voltage sensing device to confirm that all power is off.
- Do NOT depend on the product for voltage indication.
- Products rated only for basic insulation must be installed on insulated conductors.
- Current transformer secondaries (current mode) must be shorted or connected to a burden at all times.
- Remove all wire scraps and tools, replace all doors, covers and protective devices before powering the equipment.

Failure to follow these instructions will result in death or serious injury.

A qualified person is one who has skills and knowledge related to the construction and operation of this electrical equipment and installations, and has received safety training to recognize and avoid the hazards involved. NEC Article 100

If this product is used in a manner not specified by the manufacturer, the protection provided by the product may be impaired. No responsibility is assumed by Schneider Electric for any consequences arising out of the use of this material.



Observe precautions for handling static sensitive devices to avoid damage to the circuitry that is not covered under the factory warranty.

⚠ ⚠ The protective ground connection (see Figure 1) on the mounting plate should be used if the device will not be mounted to a suitably grounded surface. Assure conductivity to the protective ground.

1. Install the current sensor strips in the panel. Line up current sensors directly with the breaker terminations (Figure 4).

NOTE: The current sensors accept maximum #2 AWG (0.384" O.D.) wire with THHN insulation. Use this size wire or smaller for each circuit.

Figure 4 Installing the current sensor strips in the panel

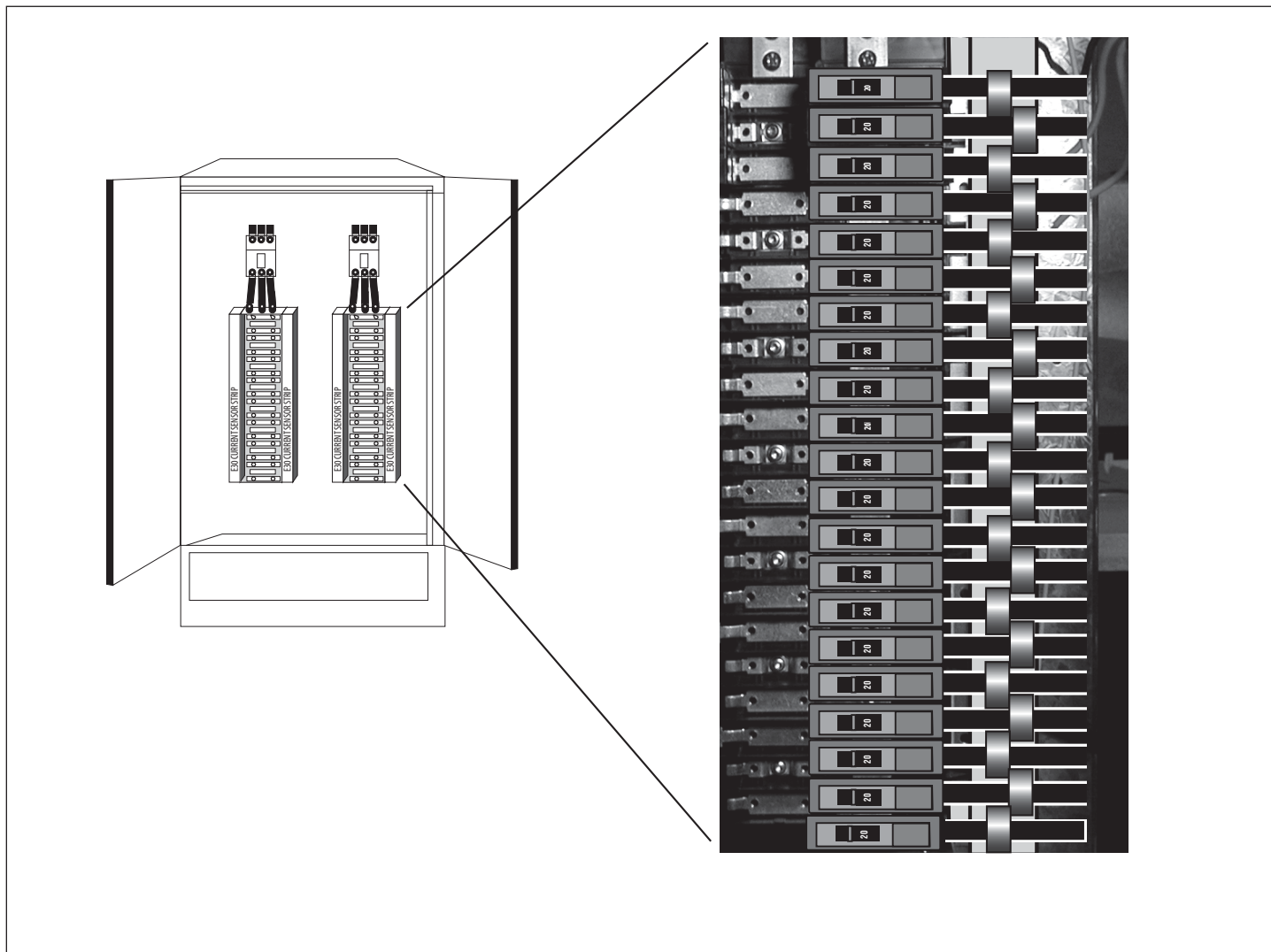

2. Arrange the current sensor strips in one of the four configurations shown in Figure 5. Adjust orientation of the circuit numbers in the field during commissioning by writing to Modbus® Register 6. For more detailed installation diagrams and help identifying what circuit configuration setting to use, refer to the Appendix titled: Panel Configuration Diagrams and Selection Matrix.

Figure 5 Circuit Number Orientation

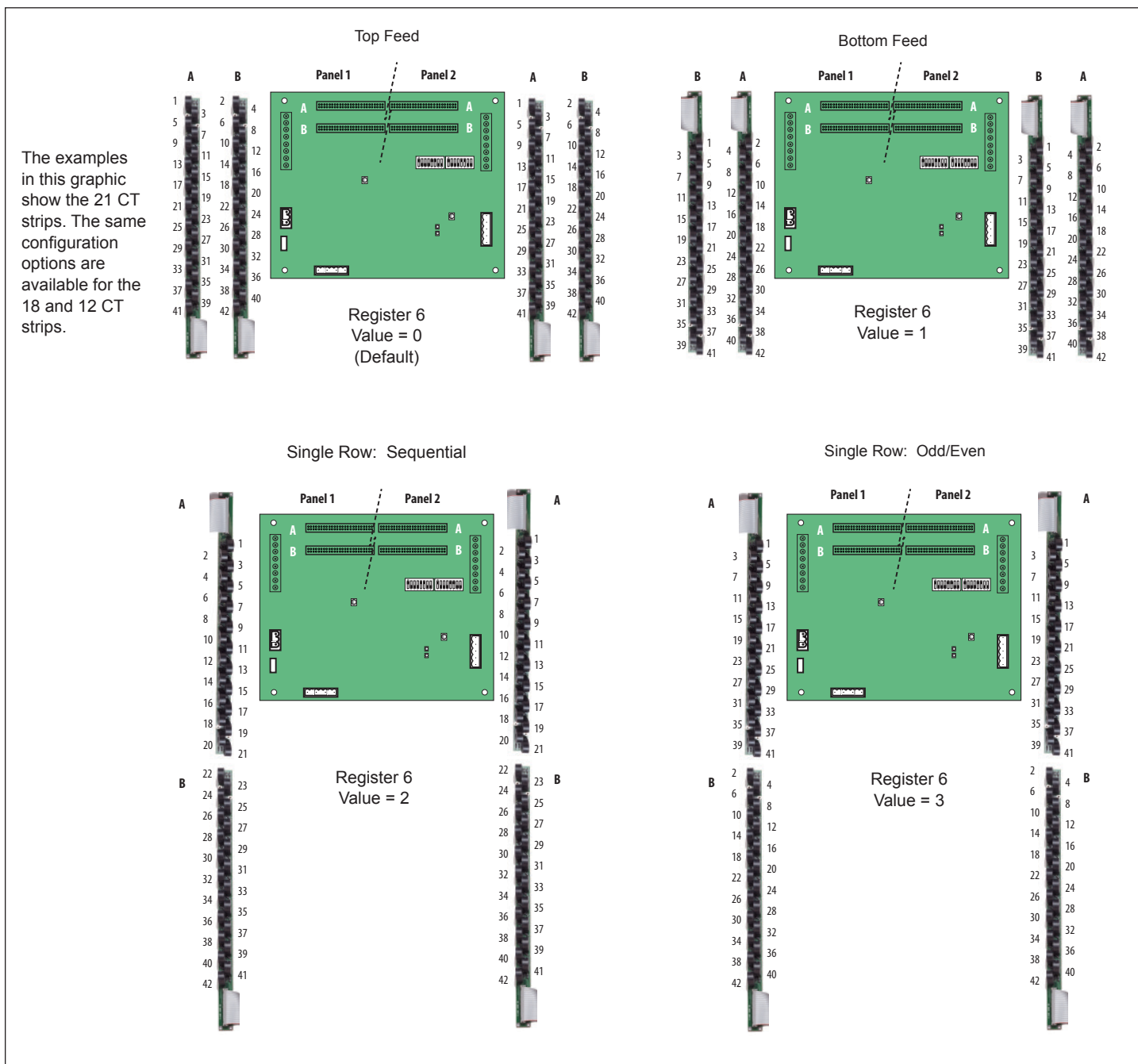

3. Check that the serial numbers printed on the current sensor strip and on the data acquisition board match. **The board and the strip are sold as a calibrated set.**
4. Configure communication and addressing parameters using DIP switches. The BCPM requires two addresses, one for each set of two current sensor strips and four auxiliary inputs. See the “Configuration” section for more information.
5. Install the BCPM data acquisition board mounting bracket in the panel (Figure 6). A grounding connection is located on the mounting bracket, near the lower right corner (See Figure 1).

Figure 6 BCPM Data Acquisition Board

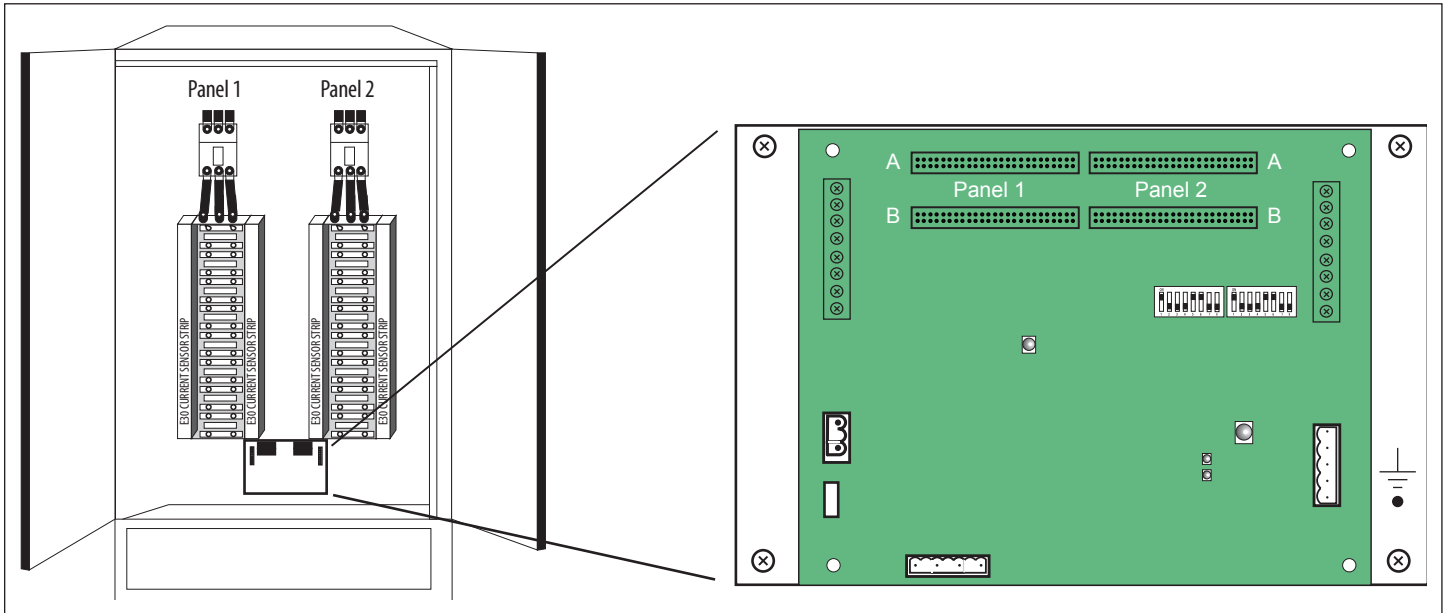

6. Check the labels on the current sensor strip and on the data acquisition board to make sure the serial numbers match. Additionally, the label indicates which connector to use on the data acquisition board (e.g. connect the strip labeled "Panel 1A" to the top left connector on the board; see Figure 7).

Figure 7 Check labels to match serial numbers

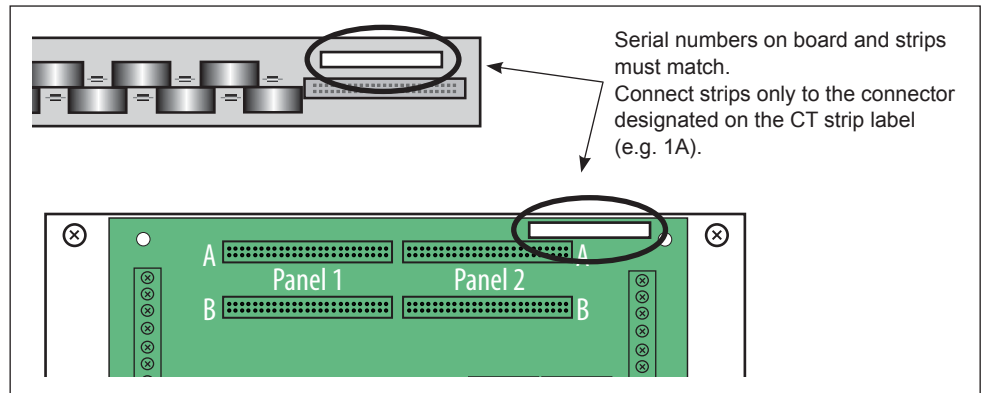

7. Connect the current sensor cables to the 50-pin connectors on the main board. (Figure 9).

Figure 8 Connectors

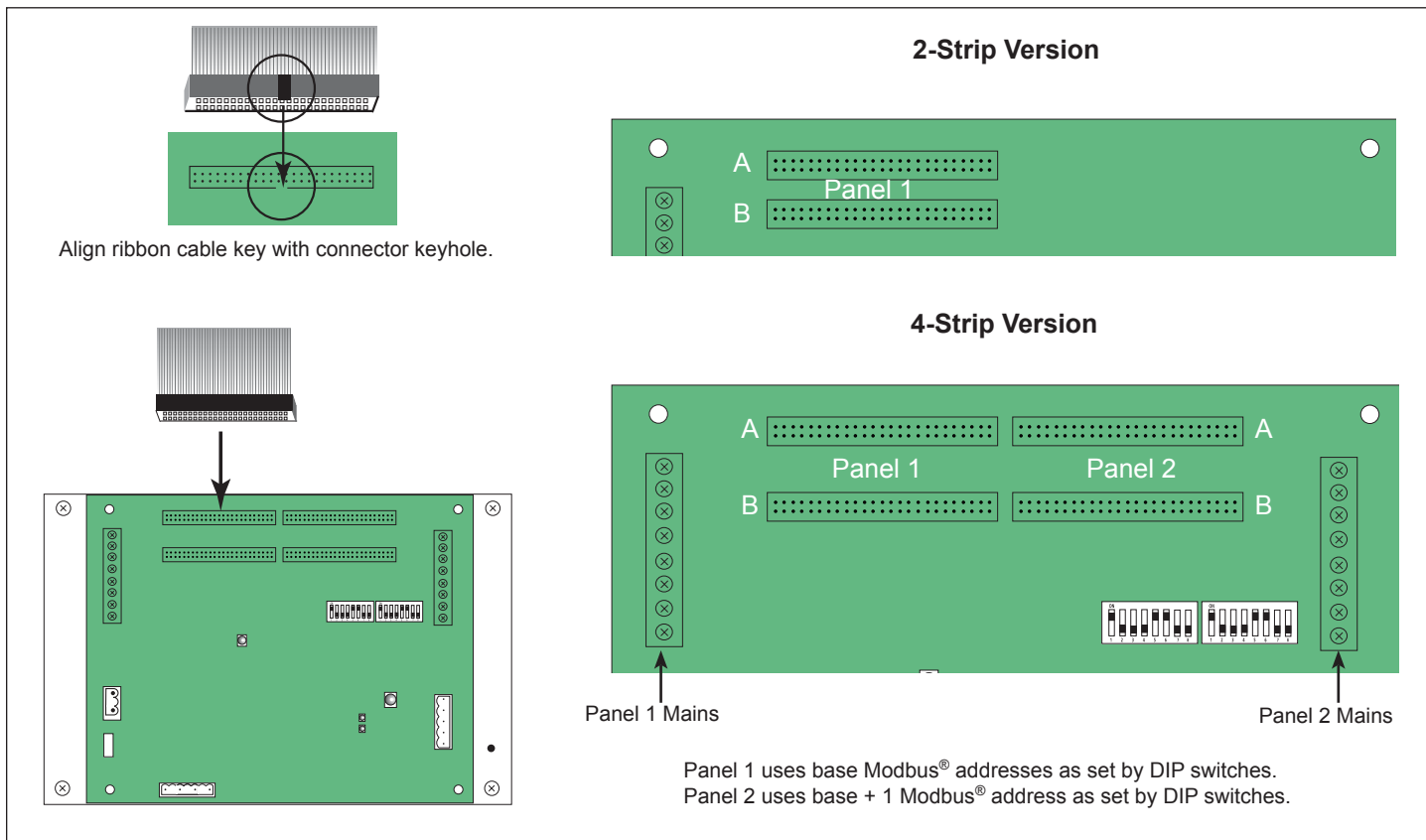

Aux CT Installation

Figure 9 Connect CTs to main conductors

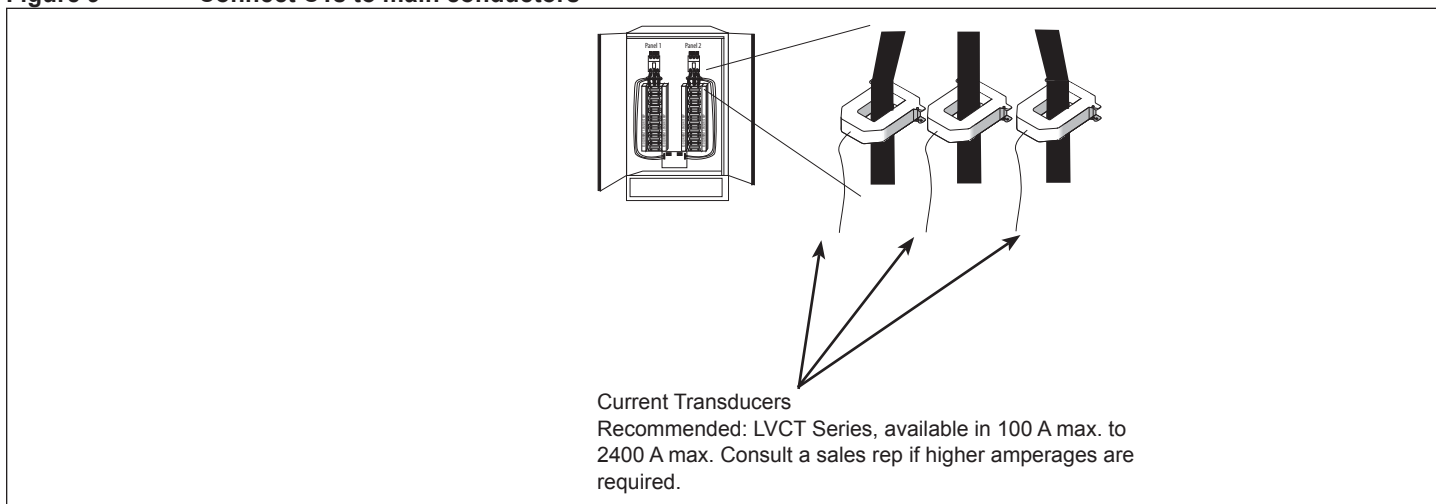

Wiring

⚡ ⚠ DANGER

HAZARD OF ELECTRIC SHOCK, EXPLOSION, OR ARC FLASH

- While removing or installing panels and covers, assure that they do not contact an energized bus.
- NEVER bypass external fusing.
- NEVER short the secondary of a potential transformer.
- Before closing covers and doors, carefully inspect the work area and remove any tools, wire scraps or other objects that may have been left inside the equipment.

Failure to follow these instructions will result in death or serious injury.

NOTE: BCPM internal circuitry (cables and CTs) are not circuits as defined by UL508A, as they do not extend beyond the BCPM itself without further fire isolation.

For all steps in this section, when tightening terminals, apply the correct torque: Aux Inputs: 3.5 to 4.4 in-lb (0.4 to 0.5 N-m); all other terminals: 4.4 to 5.3 in-lb (0.5 to 0.6 N-m). See Figure 10.

Figure 10 Torque requirements

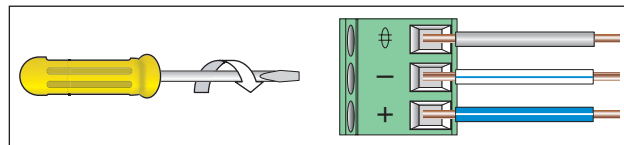

1. Connect 2-wire 90 to 277 Vac power to control power terminals. Observe polarity. For the BCPMA and BCPMB, connect voltage lines to the voltage taps (Figure 11). Provide overcurrent protection and disconnecting means to protect the wiring. Use EMFP1, EMFP2, EMFP3 fuse packs, or equivalent. Suggested: 0.5 A, time delay fuses.

Figure 11 Connecting power to power terminals

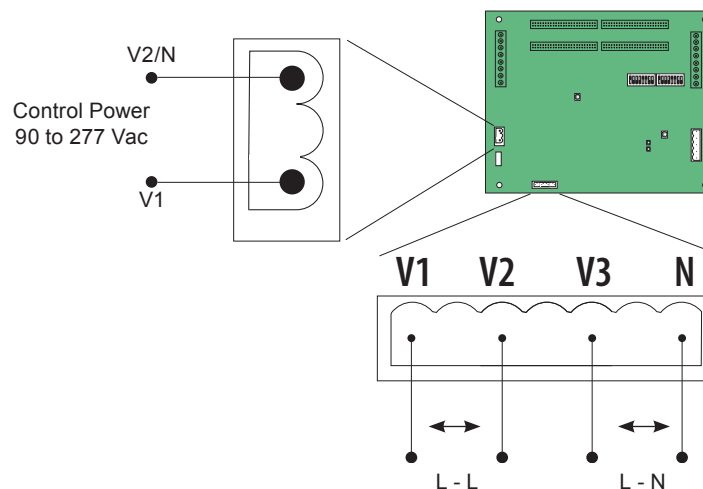

Line to Line (L-L) Voltage: 150 to 480 Vac, nominal.

Line to Neutral (L-N) voltage: 90 to 300 Vac

Voltage taps are shared by both panels.

Figure 12 Wiring Configurations

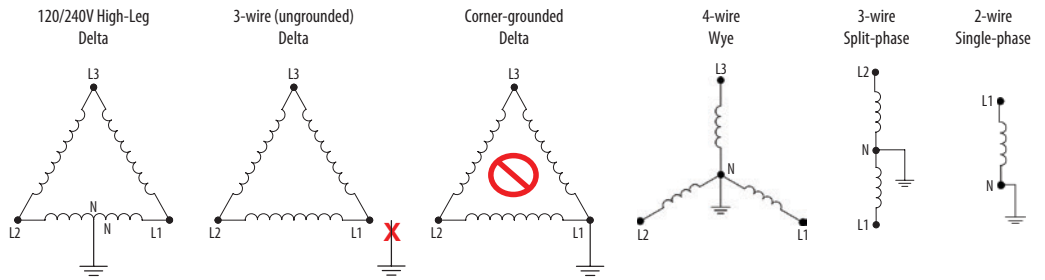

120 V/240 V Delta High Leg (where the center tap of one of the three phase-to-phase transformers is grounded): the BCPM supports these applications, as long as the line-to neutral voltage [especially of the High Leg] does not exceed 300 Vac (as in North American 120/240 V High Leg Delta configurations).

In 3-wire (ungrounded) Delta applications, the BCPM supports these applications with the following caveats:

Control Power for the meter cannot exceed 277 Vac. In applications where the L-L voltage is 277 Vac or less (e.g. 208 V line-to-line) it can be connected to two of the phases being monitored without exceeding the limit. For higher voltages (e.g. 480 V line-to-line), this must be supplied from a source that is 277 Vac or less. It could be a separate source or a transformer can be used to step it down from two of the phases being measured.

All of the CT inputs (both branches and Aux inputs) are neutral-referenced. One side of each CT is essentially connected directly to the neutral voltage input. If this is left floating, the solid-core CT strips, split-core CT adapter boards and all CTs will float at the same potential (while the panel is energized). This does not present a risk to the equipment as long as it is within 300 V of ground, but should be considered from a safety perspective in the overall application. The BCPM will provide measurements in this application with the accuracy specified, with the exception of line-to-neutral voltages, which will be calculated and reported, based on a derived virtual neutral voltage, even though they are not relevant.

Corner-grounded delta: the BCPM does not support these applications at any voltage level.

The BCPM supports measurement of all 4-wire Wye, 3-wire split-phase and 2-wire single phase and configurations that operate between 90 and 300 Vac line-to neutral.

2. Connect the (optional) 0.333 Vac CTs to the mains, observing local codes regarding bending radius (Figure 13). Refer to the appropriate CT installation instructions for further information.

Figure 13 Aux CT Connections

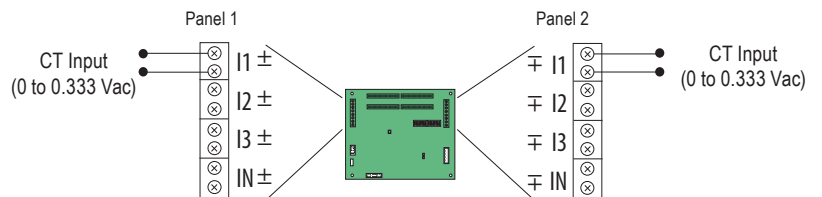

3. Connect 2-wire or 4-wire Modbus® RS-485 daisy chain network. See Figures 14 and 15.

Figure 14 Communications Connector

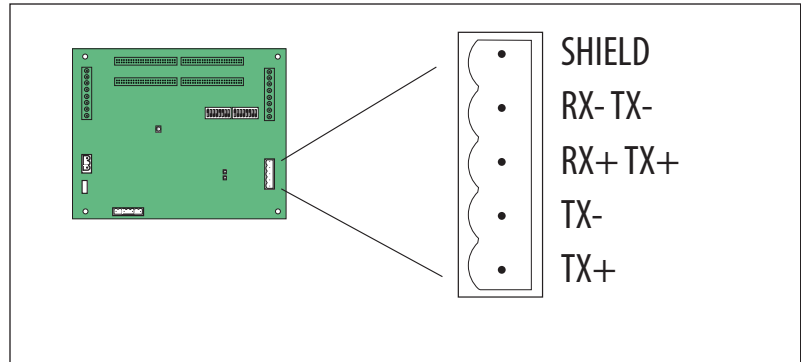
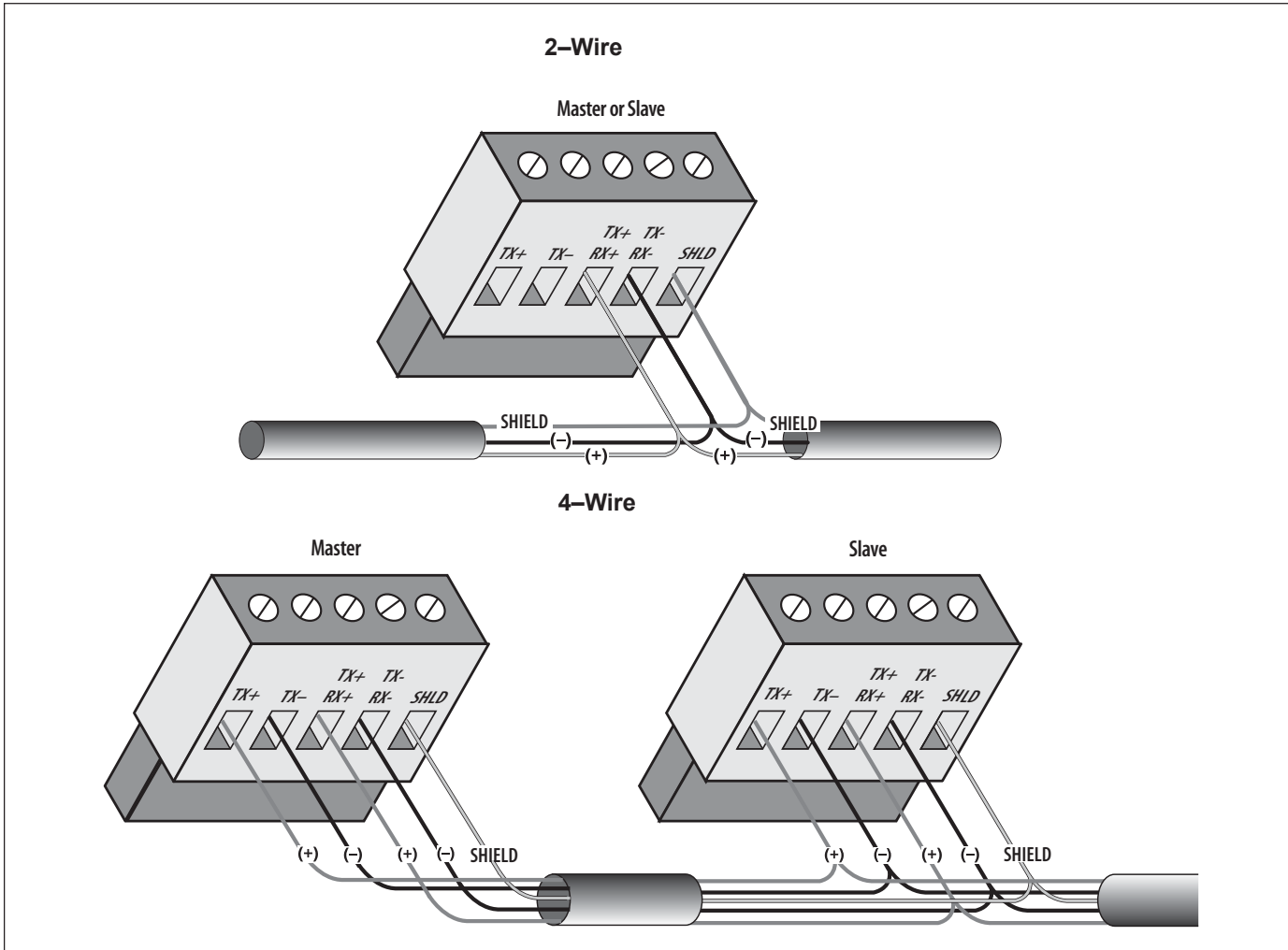
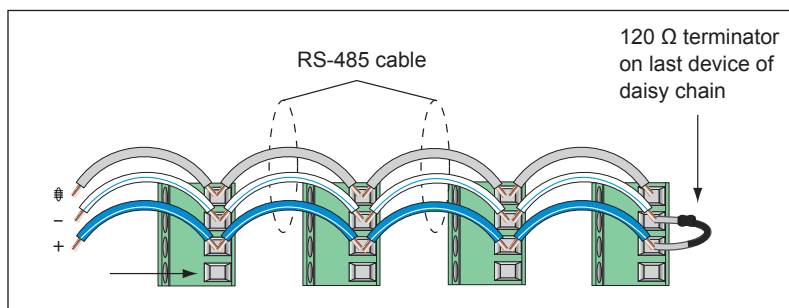

Figure 15 2-wire and 4-wire communications wiring



4. Mechanically secure the RS-485 cable(s) where they enter the electrical panel.
5. Connect all RS-485 devices together in a daisy-chain fashion, and properly terminate the chain (Figure 16).

Figure 16 Properly terminated daisy chain network



6. Shield the RS-485 cable using twisted pair wire. Use cable that is voltage rated for the installation.
7. Use ION Setup to set up breaker size, demand interval, and alarm levels. See Appendix A later in this document for more information. ION Setup is available online at www.powerlogic.com.

Configuration

1. Communications Configuration: Communications parameters for the BCPM are field selectable for your convenience. Please see the Product Diagram section for selector location. The following parameters are configurable:
 - Baud Rate: 9600, 19200, 38400
 - Parity: On or Off
 - Parity: Odd or Even
 - Wiring: 2 or 4

Figure 17 Switch settings

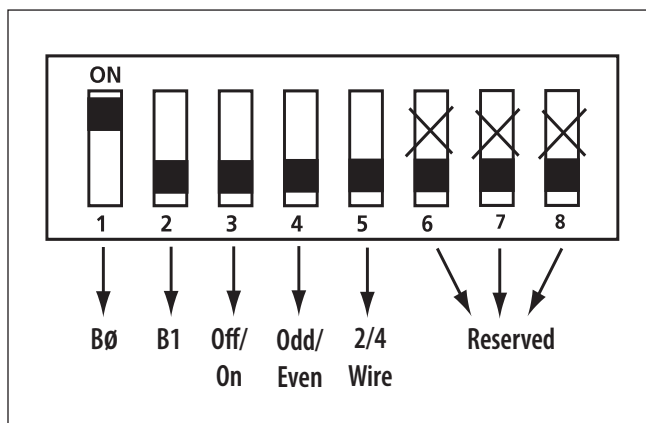
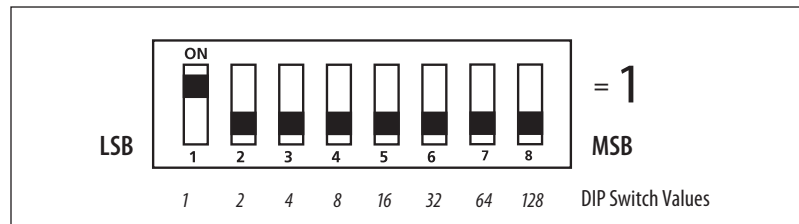

Table 6: 2-wire 19200 Baud No Parity (Default Only)

1	2	3	4	5	6	7	8	
off	off				X	X	X	9600
on	off				X	X	X	19200
off	on				X	X	X	38400
on	on				X	X	X	Custom
		off	off		X	X	X	No Parity
		on	off		X	X	X	Odd Parity
		off	on		X	X	X	No Parity
		on	on		X	X	X	Even Parity
				on	X	X	X	4-wire RS-485
				off	X	X	X	2-wire RS-485

- Each Modbus® device on a single network must have a unique address. Set the switch block to assign a unique address before the device is connected to the Modbus® RS-485 network. If an address is selected that conflicts with another device, neither device will be able to communicate.
- The BCPM uses two logical addresses. Panel 1 uses the base address as set on the DIP switches, and Panel 2 uses this base address + 1. The BCPM can be addressed as any whole number between and including 1-246. Each unit is equipped with a set of eight DIP switches for addressing (Figure 18).

Figure 18 Default switch settings



- To determine an address, add the values of any switch that is on (Figure 19).

Figure 19 Modbus® address DIP switch values

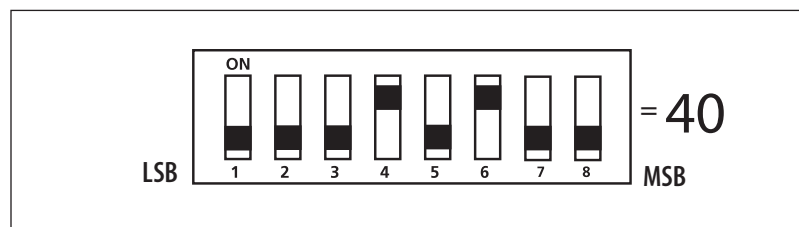

- Switch number 4 has an ON Value of 8 and switch number 6 has an ON Value of 32. (8 + 32 = 40). Therefore, the address for Panel 1 is 40, and the address for Panel 2 is 41.
- See the Communications Setup section for a pictorial listing of the first 63 switch positions.

Default DIP Switch Settings

The BCPM includes two DIP switches, as shown below. Switches are shown in their default positions.

Figure 20 Modbus Configuration DIP Switches

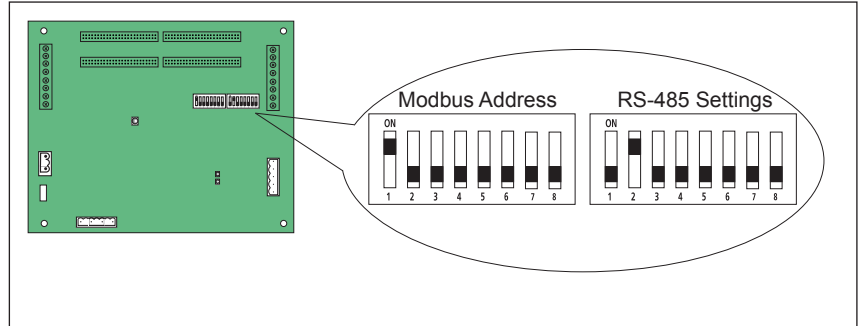

Communications Setup

Figure 21 Address selection switches from 1 to 63

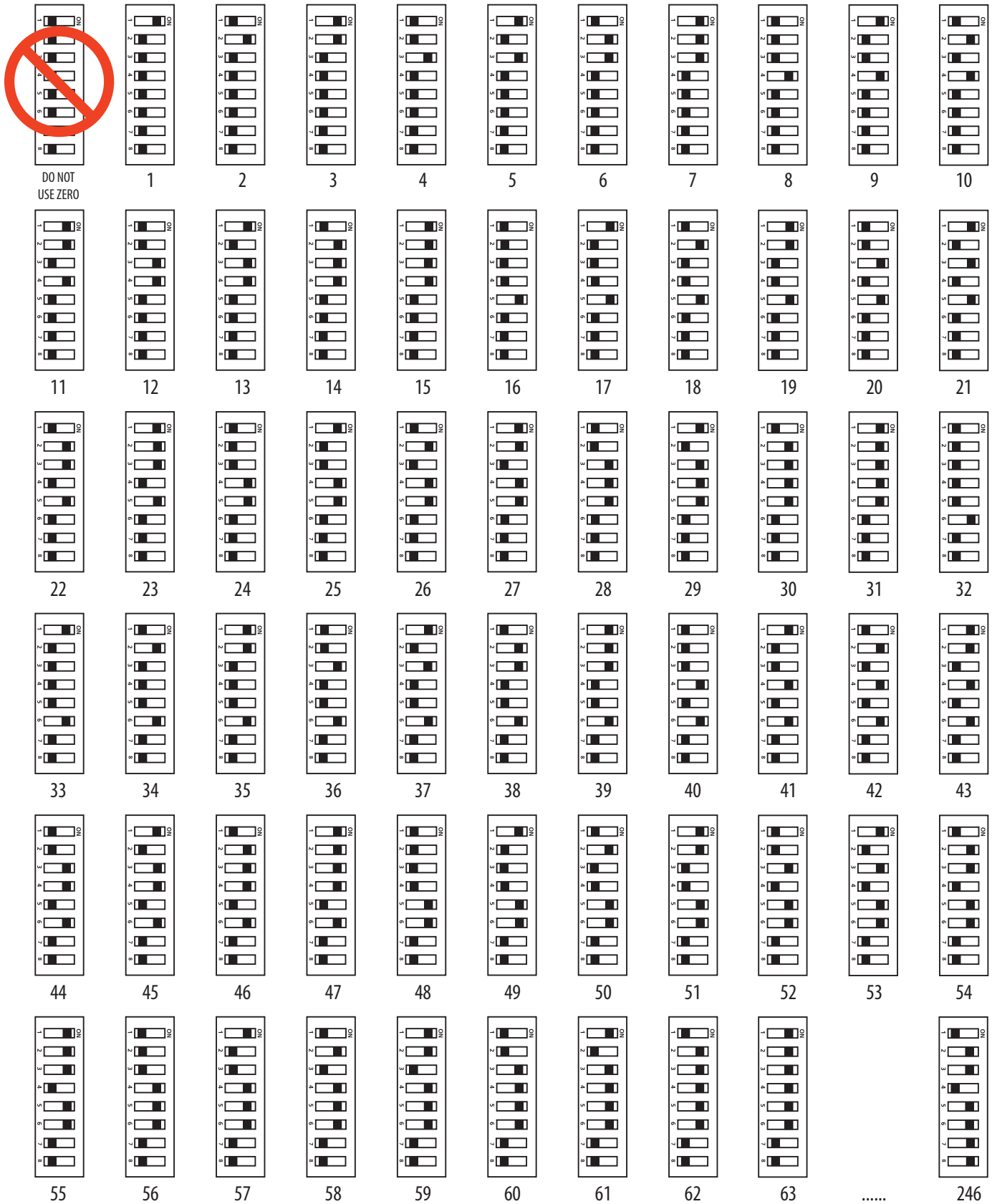

Commissioning

Use ION Setup to configure the BCPM. ION Setup is a meter configuration software you can download from www.powerlogic.com

NOTE: Install the latest build in order to get the most up-to-date information, feature and device support for ION Setup.

To learn how to add and configure sites and meters, refer to the ION Setup online help by clicking the Help button or pressing F1 on your keyboard.

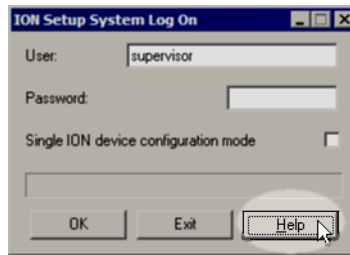

Click the Branch Circuit Power Meter topic for details on configuring the device.

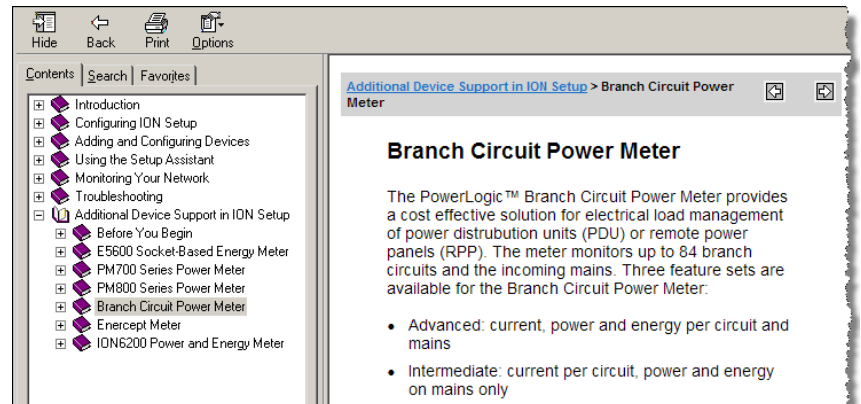

Recommended Accessories

Table 7: Recommended Accessories

Part Number	Description
CBL008	Flat ribbon cable, 50 x 28 AWG, 1.5 ft. (0.45 m)
CBL016	Flat ribbon cable, 50 x 28 AWG, 4 ft. (1.2 m)
CBL017	Flat ribbon cable, 50 x 28 AWG, 5 ft. (1.5 m)
CBL018	Flat ribbon cable, 50 x 28 AWG, 6 ft. (1.8 m)
CBL019	Flat ribbon cable, 50 x 28 AWG, 8 ft. (2.4 m)
CBL020	Flat ribbon cable, 50 x 28 AWG, 10 ft. (3.0 m)
CBL021	Flat ribbon cable, 50 x 28 AWG, 20 ft. (6.1 m)
CBL022	Round ribbon cable, 50 x 28 AWG, 4 ft. (1.2 m)
CBL023	Round ribbon cable, 50 x 28 AWG, 10 ft. (3.0 m)
CBL024	Round ribbon cable, 50 x 28 AWG, 20 ft. (6.1 m)
CBL025	Flat ribbon cable, 50 x 28 AWG, 2 m
CBL026	Flat ribbon cable, 50 x 28 AWG, 4 m
CBL027	Flat ribbon cable, 50 x 28 AWG, 6 m
CBL031	Round ribbon cable, 50 x 28 AWG, 1.5 ft. (0.45 m)
CBL032	Round ribbon cable, 50 x 28 AWG, 2.5 ft. (0.76 m)
BCPMCOVERS	Main circuit board cover, clear, Schneider brand
BCPMREPAIR	CT repair kit
SMD/SMDOPN	Net Display

Troubleshooting

NOTE: Refer to Figure 1 for component locations and descriptions.

Table 8: Troubleshooting guide

Problem	Solution
Product is not communicating over Modbus daisy chain	<ul style="list-style-type: none"> • Check the unit Modbus address to ensure that each device on the daisy chain has a unique address. • Check Parity. • Check the communications wiring. • Check that the daisy chain is properly terminated.
RX LED is on, but not flashing	<ul style="list-style-type: none"> • Check for reversed polarity on Modbus comms. • Check for sufficient biasing on the Modbus bus. Modbus physical specification calls for 450-650 Ω biasing. This is usually provided by the master.
The main board has a fast flashing amber "alive" light	<ul style="list-style-type: none"> • Check that the 1A and 1B CT strips are connected to the left top and left bottom ribbon cable connections; 2A and 2B must be connected to the right top and right bottom ribbon cable connections (see illustrations in the product installation guide). • Verify ribbon cable connectors are inserted in the correct orientation. • If cables are correct, reset main board to re-initialize product.
The main board has a slow flashing amber "alive" light	<ul style="list-style-type: none"> • One or more channels is clipping. This can be caused by a signal greater than 100 A or 277 V L-N, or by a signal with high THD near the gain stage switching points (1.5 A and 10 A).
The main board has a flashing green "alive" light	<ul style="list-style-type: none"> • Everything is wired properly and the main board has power.
The main board is a flashing or solid red "alive" light	<ul style="list-style-type: none"> • Light may be red briefly while device powers up. • If light is red for more the 60 sec. device has encountered a diagnostic event. Contact technical support.
Power factor reading is not as expected	<ul style="list-style-type: none"> • Verify voltage taps are connected in appropriate phase rotation. • Verify strip configuration register matches actual strip installation. • Verify phase rotation of breakers (firmware rev. 1.012 or higher allows for custom rotation if needed).
Current reading is not as expected, or reading is on different CT number than expected	<ul style="list-style-type: none"> • Verify strip configuration register matches actual strip installation. • Verify ribbon cable is fully seated and in the correct orientation.
Current is reading zero, even when small currents are still flowing through circuit	<ul style="list-style-type: none"> • The product cuts off at 50 mA, and will set the reporting register to 0 mA for currents near or below this range.

China RoHS Compliance Information

Table 9: EFUP Table

部件名称	有害物质 - Hazardous Substances					
Part Name	铅 (Pb)	汞 (Hg)	镉 (Cd)	六价铬 (Cr (VI))	多溴联苯 (PBB)	多溴二苯醚 (PBDE)
电子件 Electronic	X	O	O	O	O	O

本表格依据SJ/T11364的规定编制。

O: 表示该有害物质在该部件所有均质材料中的含量均在GB/T 26572规定的限量要求以下。

X: 表示该有害物质至少在该部件的某一均质材料中的含量超出GB/T 26572规定的限量要求。
(企业可在此处, 根据实际情况对上表中打“X”的技术原因进行进一步说明。)

This table is made according to SJ/T 11364.

O: indicates that the concentration of hazardous substance in all of the homogeneous materials for this part is below the limit as stipulated in GB/T 26572.

X: indicates that concentration of hazardous substance in at least one of the homogeneous materials used for this part is above the limit as stipulated in GB/T 26572

Z000057-0B

EAC Compliance Information

BCPM / BCPM-SC



www.schneider-electric.com BCPM / BCPM-SC

EAC Interstate Standards / Стандарты EAC / EAC стандарттары

en GOST 12.2.091-2012 (IEC 60010-1),
GOST 30804.6.2-2013 (IEC 61000-6-2: 2005),
GOST 30804.6.3-2013 (IEC 61000-6-3: 2006)

ru ГОСТ 12.2.091-2012 (IEC 60010-1),
ГОСТ 30804.6.2-2013 (IEC 61000-6-2: 2005),
ГОСТ 30804.6.3-2013 (IEC 61000-6-3: 2006)

kk ГОСТ 12.2.091-2012 (IEC 60010-1),
ГОСТ 30804.6.2-2013 (IEC 61000-6-2: 2005),
ГОСТ 30804.6.3-2013 (IEC 61000-6-3: 2006)

Representative Offices / Уполномоченные поставщики / Уәкілетті жеткізушілер

en Authorized suppliers:

Schneider Electric Russia

Address: 12/1 Dvintsev st., 127018 Moscow, Russia

Tel.: +7 (495) 777 99 90

Fax: +7 (495) 777 99 92

Schneider Electric Kazakhstan

Address: 151/115, Abay Ave, 12 floor, 050009 Almaty, Kazakhstan

Tel.: +7 (727) 397 04 00

Fax: +7 (727) 397 04 02

ru Уполномоченный поставщик в РФ:

АО «Шнейдер Электрик»

Адрес: 127018, Россия, г. Москва, ул. Двинцев, д.12, корп.1

Тел.: +7 (495) 777 99 90

Факс: +7 (495) 777 99 92

kk Қазақстан Республикасында уәкіл жеткізуші:

«Шнейдер Электрик» ЖШС-і

Мекен-жайы: 050009, Қазақстан, Алматы қ., Абай даңғ., 151/115, 12 қабат

Тел.: +7 (727) 397 04 00

Факс: +7 (727) 397 04 02

Serial Number Decoding / Расшифровка серийного номера / Сериялық нөмірдің мағынасын ашуы

0 6 1 5 0 5 0 2 b

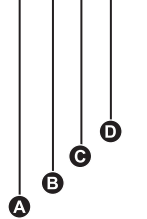

	en	ru	kk
A	Plant code	Код завода-изготовителя	Өндіруші зауыттың коды
B	Year of manufacture	Год производства	Шығарылған жылы
C	Calendar week	Календарная неделя	Күнітзбелік апта
D	Revision code	Код модификации	Түрлендірудің коды

Appendix: Panel Configuration Diagrams and Selection Matrix

To determine which installation drawing applies and which configuration to select for each logical panel of the BCPM, answer the following questions about your application and look up the corresponding information on the selection table below:

1. Are the rows of circuit breakers in your panelboard vertical (like most North American panels) or horizontal (like many European panels)?
2. Are the breakers arranged in a single row, in two rows, or in two separate panels, each with two rows?
3. If there are two rows of breakers, are the breakers/circuits in each row number sequentially, or are the odd numbers in one row and the even numbers in the other?
4. How many channels (branch CTs) does your BCPM have?
5. For vertical dual-row panels with odd/even numbering, do the main feeds come in at the top or the bottom of the chassis?

Orientation of circuit breaker rows:	Breaker Numbering within Panel:	number of E30 channels:	Single Panelboard						Two Panelboards (or Dual-Panel PDU/RPP)		
			Single Panel <=24 Breakers	Single Panel <=36 Breakers	Single Panel <=42 Breakers	Single Panel <=48 Breakers	Single Panel <=72 Breakers	Single Panel <=84 Breakers	Two Panels <=24 Breakers each	Two Panels <=36 Breakers each	Two Panels <=42 Breakers each
			24	36	42	48	72	84	48	72	84
Vertical	Dual Row - Top Feed (with Odd/Even numbering)	Installation Diagram to use:	1	2	3	7	8	9	1	2	3
		Panel 1 Configuration setting:	Top Feed	Top Feed	Top Feed	Bottom Feed	Bottom Feed	Bottom Feed	Top Feed	Top Feed	Top Feed
		Panel 2 Configuration setting:	Top Feed	Top Feed	Top Feed	Top Feed	Top Feed	Top Feed	Top Feed	Top Feed	Top Feed
	Dual Row - Bottom Feed (with Odd/Even numbering)	Installation Diagram to use:	4	5	6	7	8	9	4	5	6
		Panel 1 Configuration setting:	Bottom Feed	Bottom Feed	Bottom Feed	Bottom Feed	Bottom Feed	Bottom Feed	Bottom Feed	Bottom Feed	Bottom Feed
		Panel 2 Configuration setting:	Bottom Feed	Bottom Feed	Bottom Feed	Top Feed	Top Feed	Top Feed	Bottom Feed	Bottom Feed	Bottom Feed
	Dual Row - Top Feed (with Sequential numbering)	Installation Diagram to use:	10	11	12	13	14	15	10	11	12
		Panel 1 Configuration setting:	Sequential	Sequential	Sequential	Sequential	Sequential	Sequential	Sequential	Sequential	Sequential
		Panel 2 Configuration setting:	Sequential	Sequential	Sequential	Sequential	Sequential	Sequential	Sequential	Sequential	Sequential
	Dual Row - Bottom Feed (with Sequential numbering)	Installation Diagram to use:	10	11	12	13	14	15	10	11	12
		Panel 1 Configuration setting:	Sequential	Sequential	Sequential	Sequential	Sequential	Sequential	Sequential	Sequential	Sequential
		Panel 2 Configuration setting:	Sequential	Sequential	Sequential	Sequential	Sequential	Sequential	Sequential	Sequential	Sequential
Single Row Vertical (with Sequential numbering)	Installation Diagram to use:	16	17	18							
	Panel 1 Configuration setting:	Sequential	Sequential	Sequential							
	Panel 2 Configuration setting:	Sequential	Sequential	Sequential							
Dual Row - Any Feed (with Odd/Even numbering alternate strip mounting*)	Installation Diagram to use:			19*							
	Panel 1 Configuration setting:			Odd/Even							
	Panel 2 Configuration setting:			Odd/Even							

* this configuration is used in rare circumstances where both strips don't fit in the same orientation

Orientation of circuit breaker rows:	Rows of Circuit Breakers:	number of E30 channels:	Single Row of Breakers			Two Rows of Breakers		
			<=24 Breakers	<=36 Breakers	<=42 Breakers	<=24 Breakers per row	<=36 Breakers per row	<=42 Breakers per row
			24	36	42	48	72	84
Horizontal	Single Row (with Sequential numbering)	Installation Diagram to use:	20	21	22			
		Panel 1 Configuration setting:	Sequential	Sequential	Sequential			
		Panel 2 Configuration setting:	Sequential	Sequential	Sequential			
	Dual Row (with Sequential numbering)	Installation Diagram to use:	23	24	25	26	27	28
		Panel 1 Configuration setting:	Sequential	Sequential	Sequential	Sequential	Sequential	Sequential
		Panel 2 Configuration setting:	Sequential	Sequential	Sequential	Sequential	Sequential	Sequential

Top of Panels ↑

#1

24/48-ch Top Feed Configuration
Panel 1

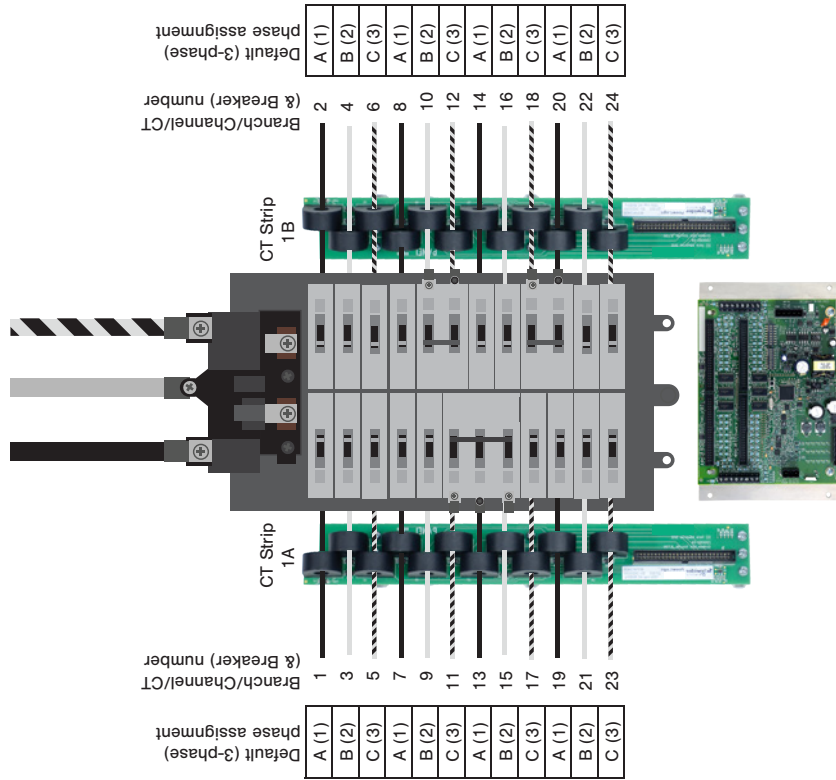

Panel 1
Set Configuration
(Modbus Register 6)
to Top Feed (0)

48-ch Top Feed Configuration
Panel 2

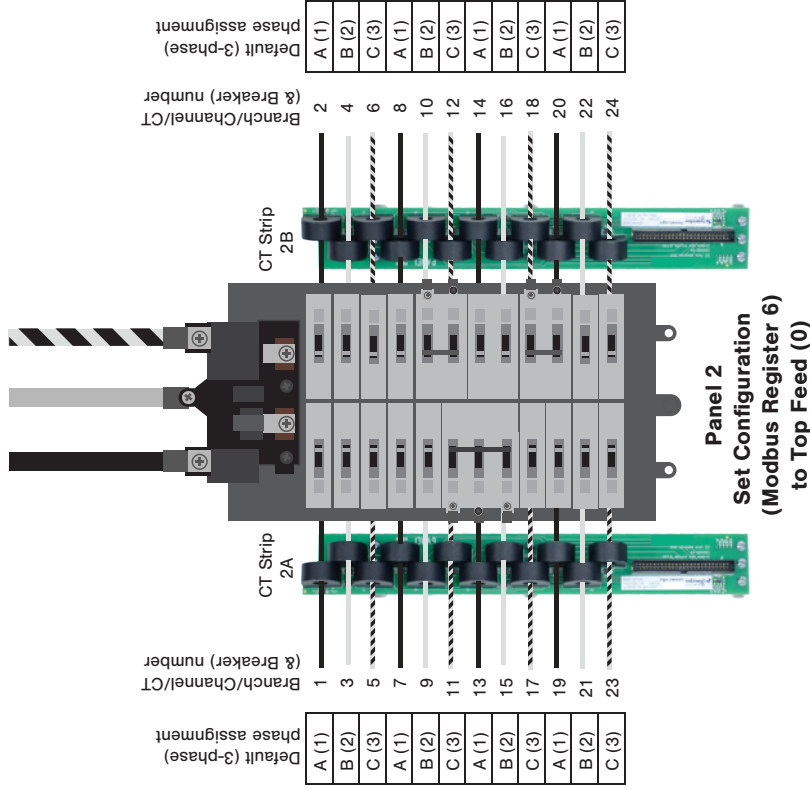

Panel 2
Set Configuration
(Modbus Register 6)
to Top Feed (0)

Top of Panels ↑

#2

36/72-ch Top Feed Configuration Panel 1

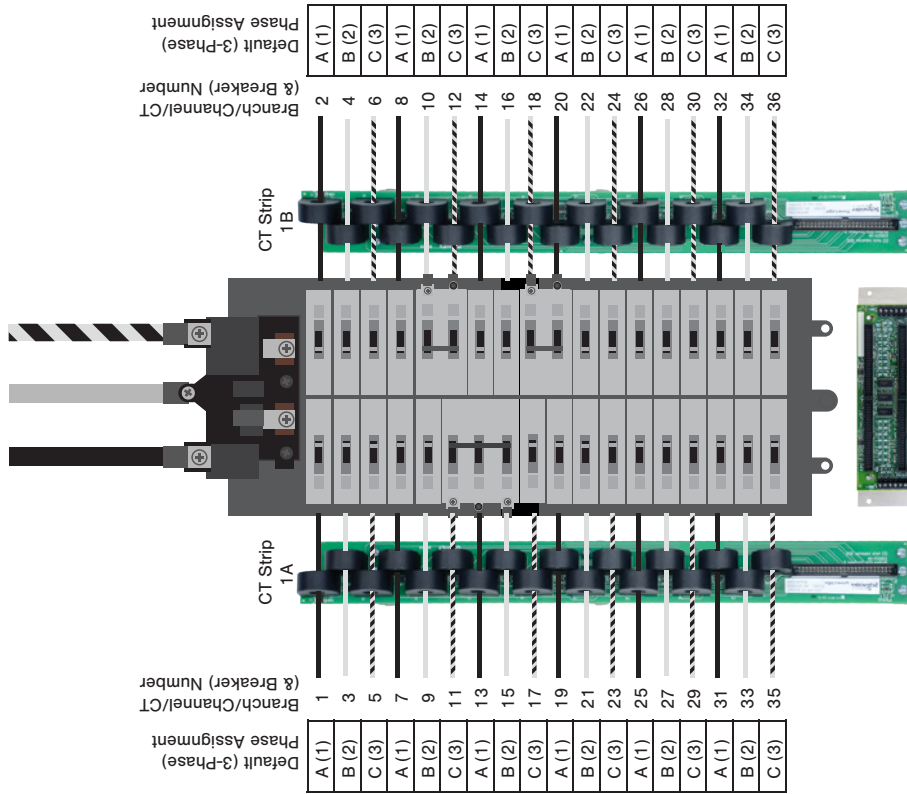

Panel 1
 Set Configuration (Modbus Register 6) to Top Feed (0)

72-ch Top Feed Configuration Panel 2

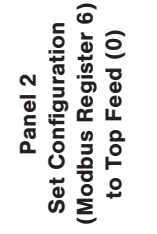
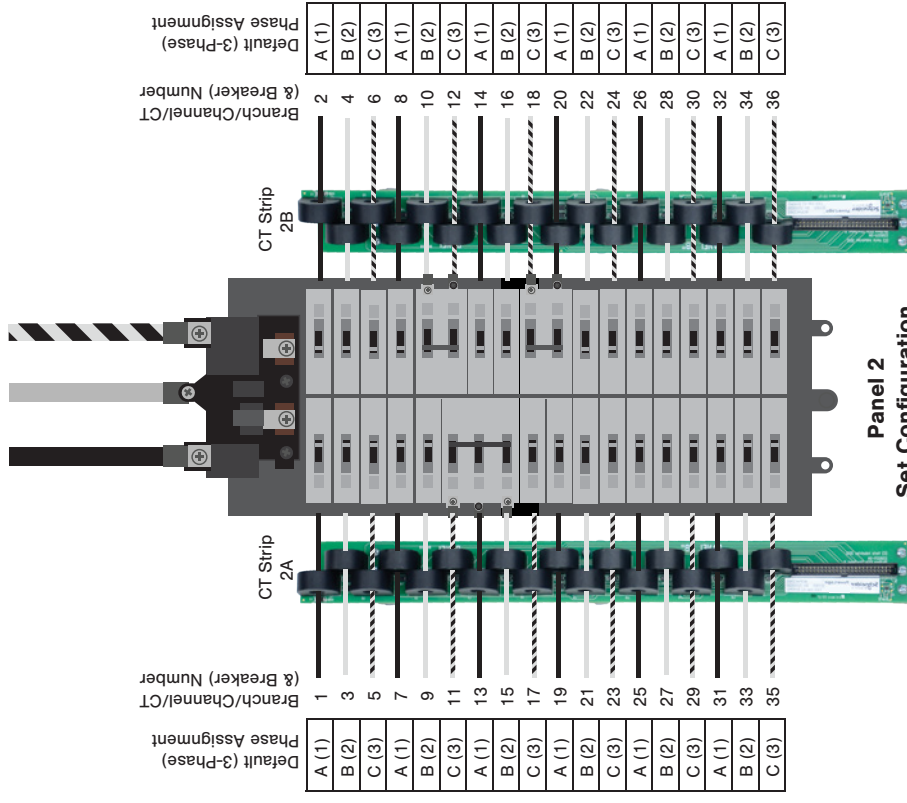

Panel 2
 Set Configuration (Modbus Register 6) to Top Feed (0)

#3

Top of Panels ←

42/84-ch Top Feed Configuration
Panel 1

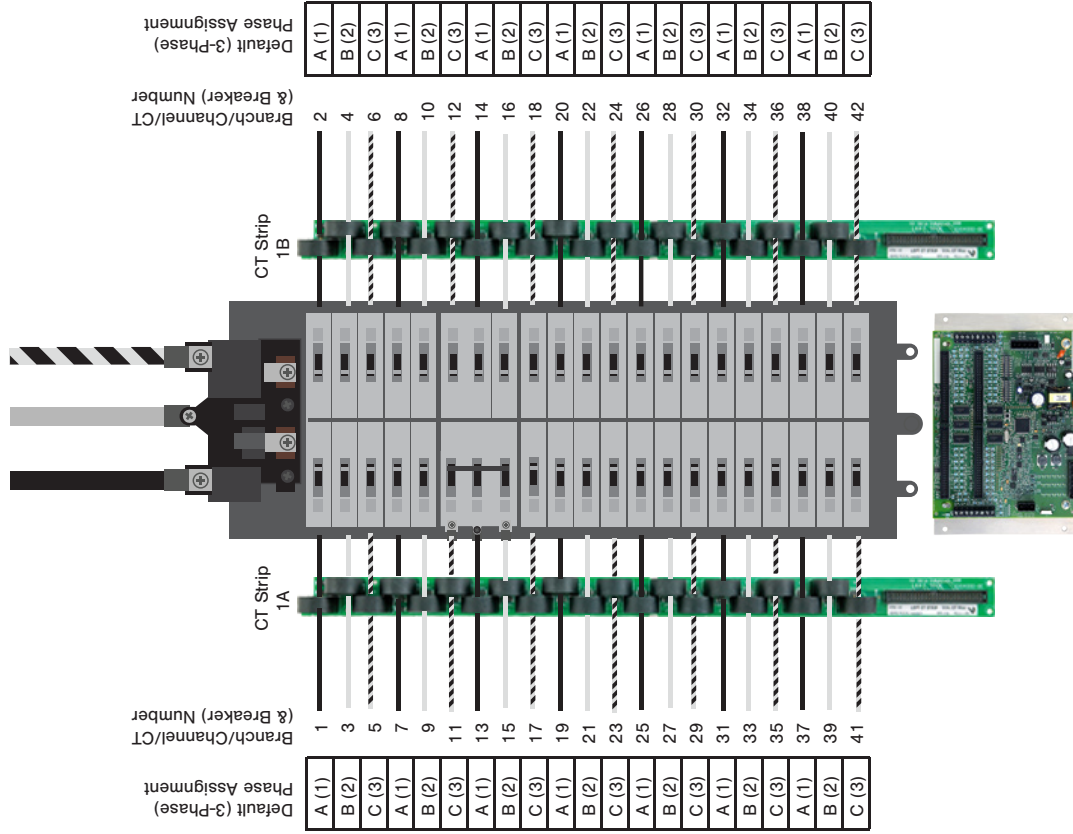

Panel 1
Set Configuration (Modbus Register 6) to Top Feed (0)

84-ch Top Feed Configuration
Panel 2

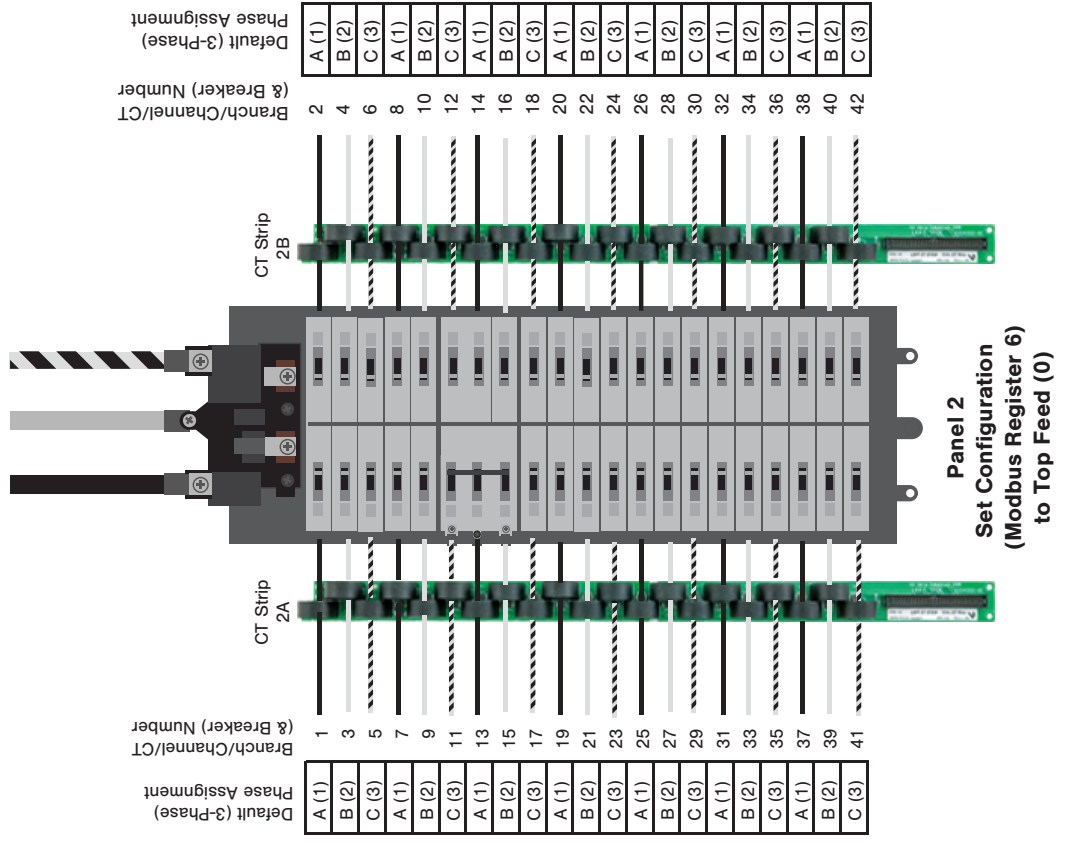

Panel 2
Set Configuration (Modbus Register 6) to Top Feed (0)

Top of Panels ↑

#4

24/48-ch Bottom Feed Configuration Panel 1

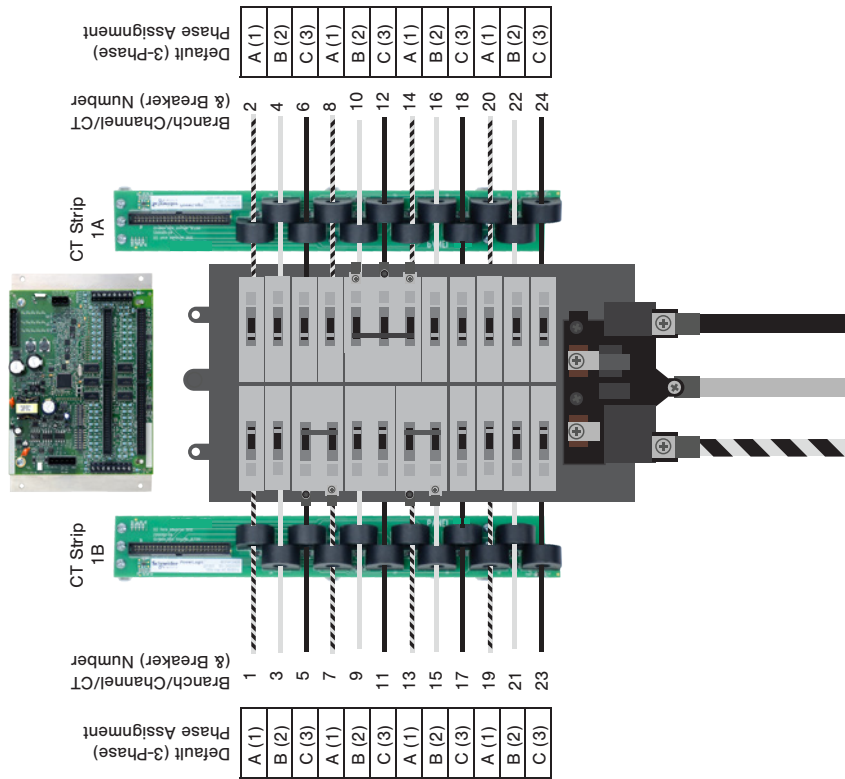

Panel 1
 Set Configuration (Modbus Register 6) to Bottom Feed (1)

48-ch Bottom Feed Configuration Panel 2

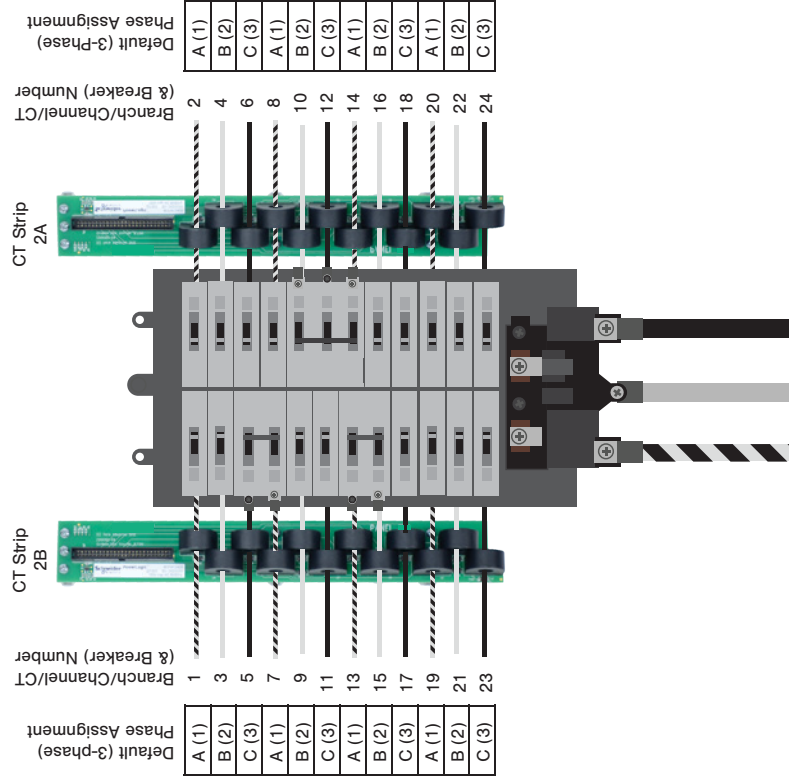

Panel 2
 Set Configuration (Modbus Register 6) to Bottom Feed (1)

#5

Top of Panels ↑

36/72-ch Bottom Feed Configuration Panel 1



Phase Assignment	A (1)	B (2)	C (3)	A (1)	B (2)	C (3)	A (1)	B (2)	C (3)	A (1)	B (2)	C (3)	A (1)	B (2)	C (3)	A (1)	B (2)	C (3)	A (1)	B (2)	C (3)	A (1)	B (2)	C (3)	A (1)	B (2)	C (3)	A (1)	B (2)	C (3)		
Branch/Channel/CT (& Breaker) Number	1	3	5	7	9	11	13	15	17	19	21	23	25	27	29	31	33	35														



Phase Assignment	A (1)	B (2)	C (3)	A (1)	B (2)	C (3)	A (1)	B (2)	C (3)	A (1)	B (2)	C (3)	A (1)	B (2)	C (3)	A (1)	B (2)	C (3)	A (1)	B (2)	C (3)	A (1)	B (2)	C (3)	A (1)	B (2)	C (3)	A (1)	B (2)	C (3)		
Branch/Channel/CT (& Breaker) Number	2	4	6	8	10	12	14	16	18	20	22	24	26	28	30	32	34	36														



Phase Assignment	A (1)	B (2)	C (3)	A (1)	B (2)	C (3)	A (1)	B (2)	C (3)	A (1)	B (2)	C (3)	A (1)	B (2)	C (3)	A (1)	B (2)	C (3)	A (1)	B (2)	C (3)	A (1)	B (2)	C (3)	A (1)	B (2)	C (3)	A (1)	B (2)	C (3)		
Branch/Channel/CT (& Breaker) Number	1	3	5	7	9	11	13	15	17	19	21	23	25	27	29	31	33	35														



72-ch Bottom Feed Configuration Panel 2

Panel 1
 Set Configuration (Modbus Register 6) to Bottom Feed (1)

Panel 2
 Set Configuration (Modbus Register 6) to Bottom Feed (1)

#6

Top of Panels ←

42/84-ch Bottom Feed Configuration Panel 1



Branch/Channel/CT (& Breaker) Number	1	3	5	7	9	11	13	15	17	19	21	23	25	27	29	31	33	35	37	39	41
Default (3-Phase) Phase Assignment	A (1)	B (2)	C (3)	A (1)	B (2)	C (3)	A (1)	B (2)	C (3)	A (1)	B (2)	C (3)	A (1)	B (2)	C (3)	A (1)	B (2)	C (3)	A (1)	B (2)	C (3)

Branch/Channel/CT (& Breaker) Number	2	4	6	8	10	12	14	16	18	20	22	24	26	28	30	32	34	36	38	40	42
Default (3-Phase) Phase Assignment	A (1)	B (2)	C (3)	A (1)	B (2)	C (3)	A (1)	B (2)	C (3)	A (1)	B (2)	C (3)	A (1)	B (2)	C (3)	A (1)	B (2)	C (3)	A (1)	B (2)	C (3)

Branch/Channel/CT (& Breaker) Number	1	3	5	7	9	11	13	15	17	19	21	23	25	27	29	31	33	35	37	39	41
Default (3-Phase) Phase Assignment	A (1)	B (2)	C (3)	A (1)	B (2)	C (3)	A (1)	B (2)	C (3)	A (1)	B (2)	C (3)	A (1)	B (2)	C (3)	A (1)	B (2)	C (3)	A (1)	B (2)	C (3)

Branch/Channel/CT (& Breaker) Number	2	4	6	8	10	12	14	16	18	20	22	24	26	28	30	32	34	36	38	40	42
Default (3-Phase) Phase Assignment	A (1)	B (2)	C (3)	A (1)	B (2)	C (3)	A (1)	B (2)	C (3)	A (1)	B (2)	C (3)	A (1)	B (2)	C (3)	A (1)	B (2)	C (3)	A (1)	B (2)	C (3)

Branch/Channel/CT (& Breaker) Number	2	4	6	8	10	12	14	16	18	20	22	24	26	28	30	32	34	36	38	40	42
Default (3-Phase) Phase Assignment	A (1)	B (2)	C (3)	A (1)	B (2)	C (3)	A (1)	B (2)	C (3)	A (1)	B (2)	C (3)	A (1)	B (2)	C (3)	A (1)	B (2)	C (3)	A (1)	B (2)	C (3)

84-ch Bottom Feed Configuration Panel 2



Branch/Channel/CT (& Breaker) Number	1	3	5	7	9	11	13	15	17	19	21	23	25	27	29	31	33	35	37	39	41
Default (3-Phase) Phase Assignment	A (1)	B (2)	C (3)	A (1)	B (2)	C (3)	A (1)	B (2)	C (3)	A (1)	B (2)	C (3)	A (1)	B (2)	C (3)	A (1)	B (2)	C (3)	A (1)	B (2)	C (3)

Branch/Channel/CT (& Breaker) Number	2	4	6	8	10	12	14	16	18	20	22	24	26	28	30	32	34	36	38	40	42
Default (3-Phase) Phase Assignment	A (1)	B (2)	C (3)	A (1)	B (2)	C (3)	A (1)	B (2)	C (3)	A (1)	B (2)	C (3)	A (1)	B (2)	C (3)	A (1)	B (2)	C (3)	A (1)	B (2)	C (3)

Branch/Channel/CT (& Breaker) Number	1	3	5	7	9	11	13	15	17	19	21	23	25	27	29	31	33	35	37	39	41
Default (3-Phase) Phase Assignment	A (1)	B (2)	C (3)	A (1)	B (2)	C (3)	A (1)	B (2)	C (3)	A (1)	B (2)	C (3)	A (1)	B (2)	C (3)	A (1)	B (2)	C (3)	A (1)	B (2)	C (3)

Branch/Channel/CT (& Breaker) Number	2	4	6	8	10	12	14	16	18	20	22	24	26	28	30	32	34	36	38	40	42
Default (3-Phase) Phase Assignment	A (1)	B (2)	C (3)	A (1)	B (2)	C (3)	A (1)	B (2)	C (3)	A (1)	B (2)	C (3)	A (1)	B (2)	C (3)	A (1)	B (2)	C (3)	A (1)	B (2)	C (3)

Branch/Channel/CT (& Breaker) Number	2	4	6	8	10	12	14	16	18	20	22	24	26	28	30	32	34	36	38	40	42
Default (3-Phase) Phase Assignment	A (1)	B (2)	C (3)	A (1)	B (2)	C (3)	A (1)	B (2)	C (3)	A (1)	B (2)	C (3)	A (1)	B (2)	C (3)	A (1)	B (2)	C (3)	A (1)	B (2)	C (3)

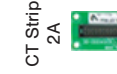

Branch/Channel/CT (& Breaker) Number	1	3	5	7	9	11	13	15	17	19	21	23	25	27	29	31	33	35	37	39	41
Default (3-Phase) Phase Assignment	A (1)	B (2)	C (3)	A (1)	B (2)	C (3)	A (1)	B (2)	C (3)	A (1)	B (2)	C (3)	A (1)	B (2)	C (3)	A (1)	B (2)	C (3)	A (1)	B (2)	C (3)

Branch/Channel/CT (& Breaker) Number	2	4	6	8	10	12	14	16	18	20	22	24	26	28	30	32	34	36	38	40	42
Default (3-Phase) Phase Assignment	A (1)	B (2)	C (3)	A (1)	B (2)	C (3)	A (1)	B (2)	C (3)	A (1)	B (2)	C (3)	A (1)	B (2)	C (3)	A (1)	B (2)	C (3)	A (1)	B (2)	C (3)

Branch/Channel/CT (& Breaker) Number	1	3	5	7	9	11	13	15	17	19	21	23	25	27	29	31	33	35	37	39	41
Default (3-Phase) Phase Assignment	A (1)	B (2)	C (3)	A (1)	B (2)	C (3)	A (1)	B (2)	C (3)	A (1)	B (2)	C (3)	A (1)	B (2)	C (3)	A (1)	B (2)	C (3)	A (1)	B (2)	C (3)

Branch/Channel/CT (& Breaker) Number	2	4	6	8	10	12	14	16	18	20	22	24	26	28	30	32	34	36	38	40	42
Default (3-Phase) Phase Assignment	A (1)	B (2)	C (3)	A (1)	B (2)	C (3)	A (1)	B (2)	C (3)	A (1)	B (2)	C (3)	A (1)	B (2)	C (3)	A (1)	B (2)	C (3)	A (1)	B (2)	C (3)

Branch/Channel/CT (& Breaker) Number	2	4	6	8	10	12	14	16	18	20	22	24	26	28	30	32	34	36	38	40	42
Default (3-Phase) Phase Assignment	A (1)	B (2)	C (3)	A (1)	B (2)	C (3)	A (1)	B (2)	C (3)	A (1)	B (2)	C (3)	A (1)	B (2)	C (3)	A (1)	B (2)	C (3)	A (1)	B (2)	C (3)

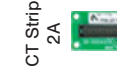

#7

Top of Panel ↑

48-ch Large Panel Odd/Even Configuration

Note: This application does NOT use the Odd/Even configuration setting.

Panel 1 (Upper Half)
 Set Configuration
 (Modbus Register 6)
 to Bottom Feed (1)

Default (3-Phase) Phase Assignment	Branch/Channel/CT Number	Breaker Number
A (1)	1	1
B (2)	3	3
C (3)	5	5
A (1)	7	7
B (2)	9	9
C (3)	11	11
A (1)	13	13
B (2)	15	15
C (3)	17	17
A (1)	19	19
B (2)	21	21
C (3)	23	23

A (1)	1	25
B (2)	3	27
C (3)	5	29
A (1)	7	31
B (2)	9	33
C (3)	11	35
A (1)	13	37
B (2)	15	39
C (3)	17	41
A (1)	19	43
B (2)	21	45
C (3)	23	47

Panel 2 (Lower Half)
 Set Configuration
 (Modbus Register 6)
 to Top Feed (0)

Panel 1 (Upper Half)
 Set Configuration
 (Modbus Register 6)
 to Bottom Feed (1)

Breaker Number	Branch/Channel/CT Number	Default (3-Phase) Phase Assignment
2	2	A (1)
4	4	B (2)
6	6	C (3)
8	8	A (1)
10	10	B (2)
12	12	C (3)
14	14	A (1)
16	16	B (2)
18	18	C (3)
20	20	A (1)
22	22	B (2)
24	24	C (3)

26	2	A (1)
28	4	B (2)
30	6	C (3)
32	8	A (1)
34	10	B (2)
36	12	C (3)
38	14	A (1)
40	16	B (2)
42	18	C (3)
44	20	A (1)
46	22	B (2)
48	24	C (3)

Panel 2 (Lower Half)
 Set Configuration
 (Modbus Register 6)
 to Top Feed (0)

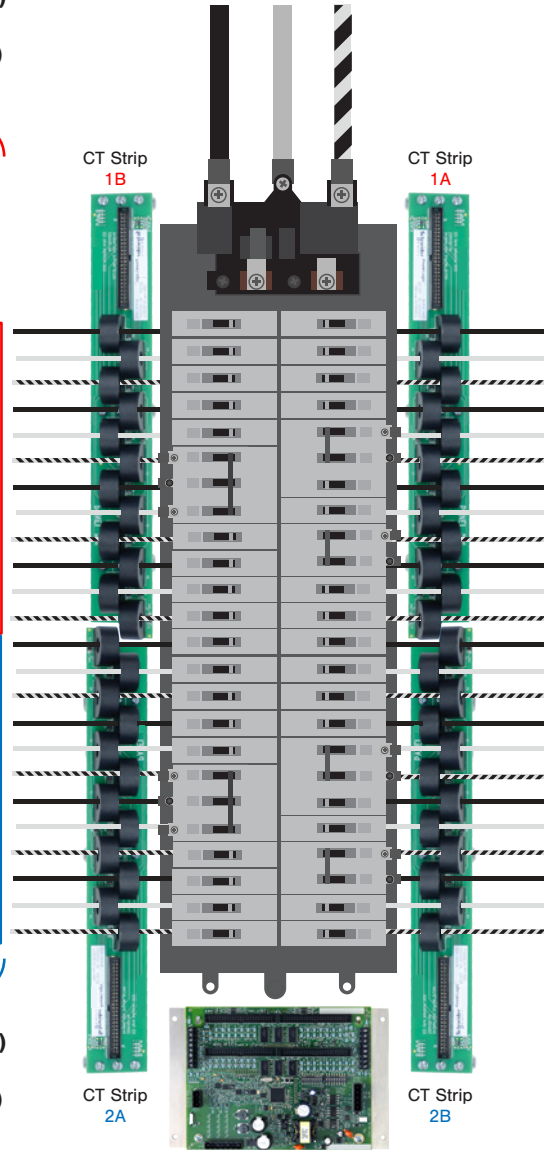

#8

Top of Panel ↑

72-ch Large Panel Odd/Even Configuration

Note: This application does NOT use the Odd/Even configuration setting.

Panel 1 (Upper Half)
Set Configuration
(Modbus Register 6)
to Bottom Feed (1)

Default (3-Phase) Phase Assignment	Branch/Channel/CT Number	Breaker Number
A (1)	1	1
B (2)	3	3
C (3)	5	5
A (1)	7	7
B (2)	9	9
C (3)	11	11
A (1)	13	13
B (2)	15	15
C (3)	17	17
A (1)	19	19
B (2)	21	21
C (3)	23	23
A (1)	25	25
B (2)	27	27
C (3)	29	29
A (1)	31	31
B (2)	33	33
C (3)	35	35

A (1)	1	37
B (2)	3	39
C (3)	5	41
A (1)	7	43
B (2)	9	45
C (3)	11	47
A (1)	13	49
B (2)	15	51
C (3)	17	53
A (1)	19	55
B (2)	21	57
C (3)	23	59
A (1)	25	61
B (2)	27	63
C (3)	29	65
A (1)	31	67
B (2)	33	69
C (3)	35	71

Panel 2 (Lower Half)
Set Configuration
(Modbus Register 6)
to Top Feed (0)

Panel 1 (Upper Half)
Set Configuration
(Modbus Register 6)
to Bottom Feed (1)

Breaker Number	Branch/Channel/CT Number	Default (3-Phase) Phase Assignment
2	2	A (1)
4	4	B (2)
6	6	C (3)
8	8	A (1)
10	10	B (2)
12	12	C (3)
14	14	A (1)
16	16	B (2)
18	18	C (3)
20	20	A (1)
22	22	B (2)
24	24	C (3)
26	26	A (1)
28	28	B (2)
30	30	C (3)
32	32	A (1)
34	34	B (2)
36	36	C (3)

38	2	A (1)
40	4	B (2)
42	6	C (3)
44	8	A (1)
46	10	B (2)
48	12	C (3)
50	14	A (1)
52	16	B (2)
54	18	C (3)
56	20	A (1)
58	22	B (2)
60	24	C (3)
62	26	A (1)
64	28	B (2)
66	30	C (3)
68	32	A (1)
70	34	B (2)
72	36	C (3)

Panel 2 (Lower Half)
Set Configuration
(Modbus Register 6)
to Top Feed (0)

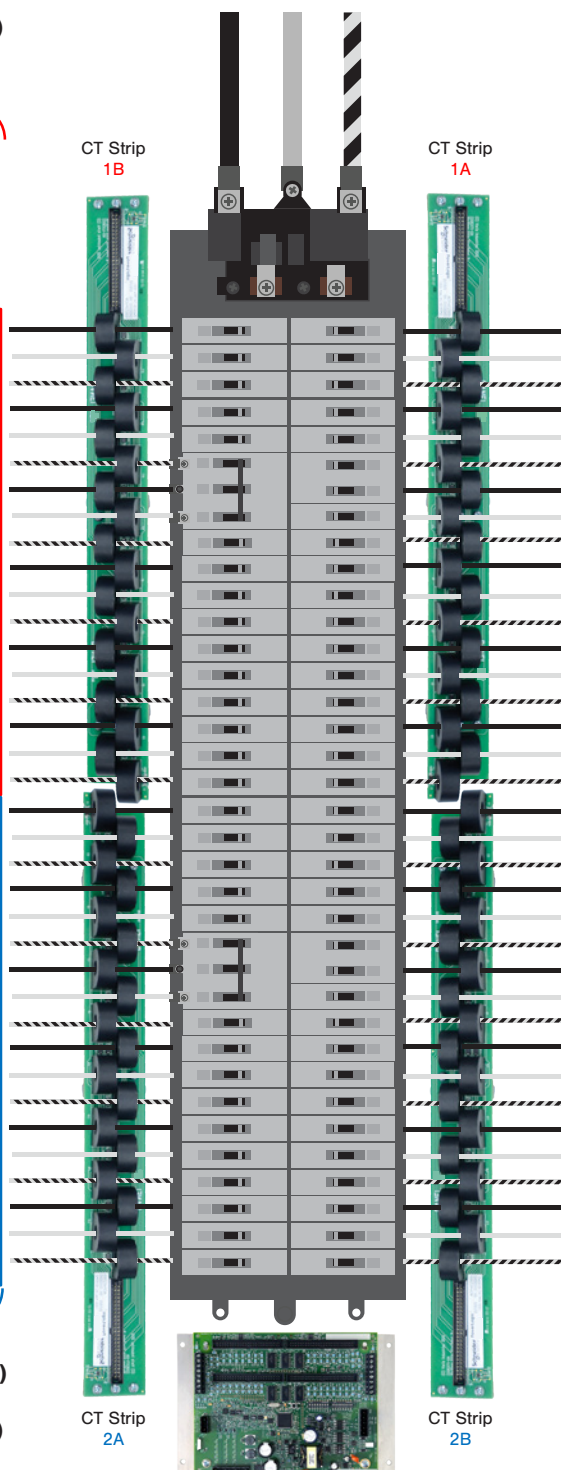

#9

Top of Panel ↑

84-ch Large Panel Odd/Even Configuration

Note: This application does NOT use the Odd/Even configuration setting.

Panel 1 (Upper Half)
Set Configuration (Modbus Register 6)
to Bottom Feed (1)

Panel 1 (Upper Half)
Set Configuration (Modbus Register 6)
to Bottom Feed (1)

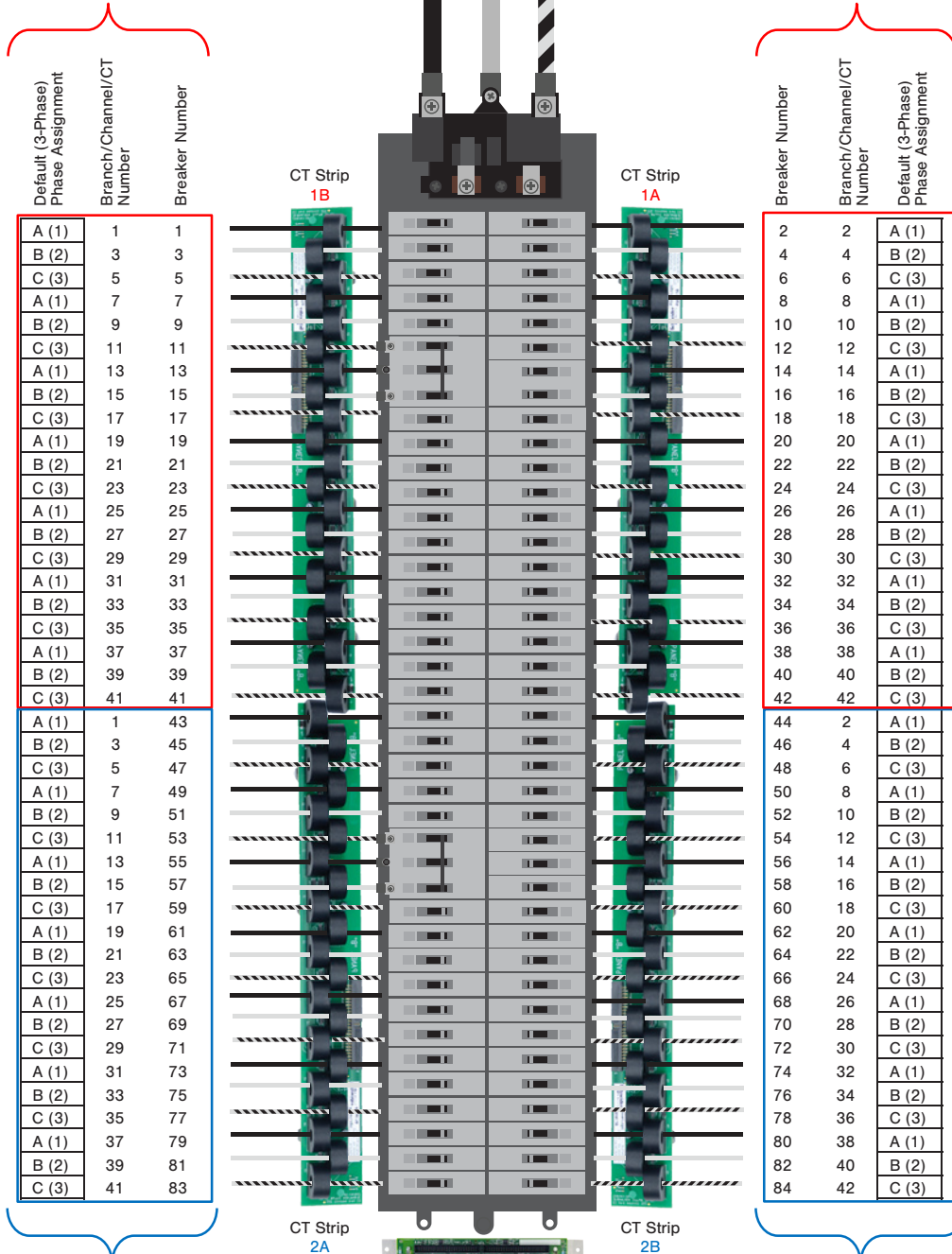

Panel 2 (Upper Half)
Set Configuration (Modbus Register 6)
to Top Feed (0)

Panel 2 (Upper Half)
Set Configuration (Modbus Register 6)
to Top Feed (0)

#10

Top of Panels ↑

24/48-ch Top Feed Configuration
 Panel 1

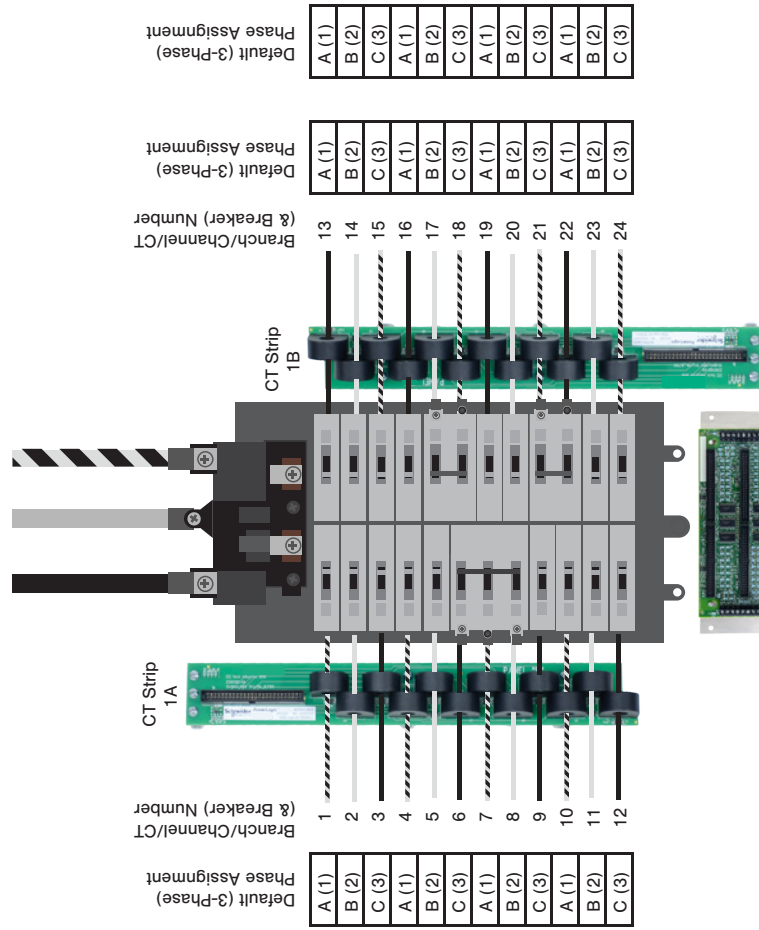

Panel 1
 Set Configuration
 (Modbus Register 6)
 to Sequential (2)

48-ch Top Feed Configuration
 Panel 2

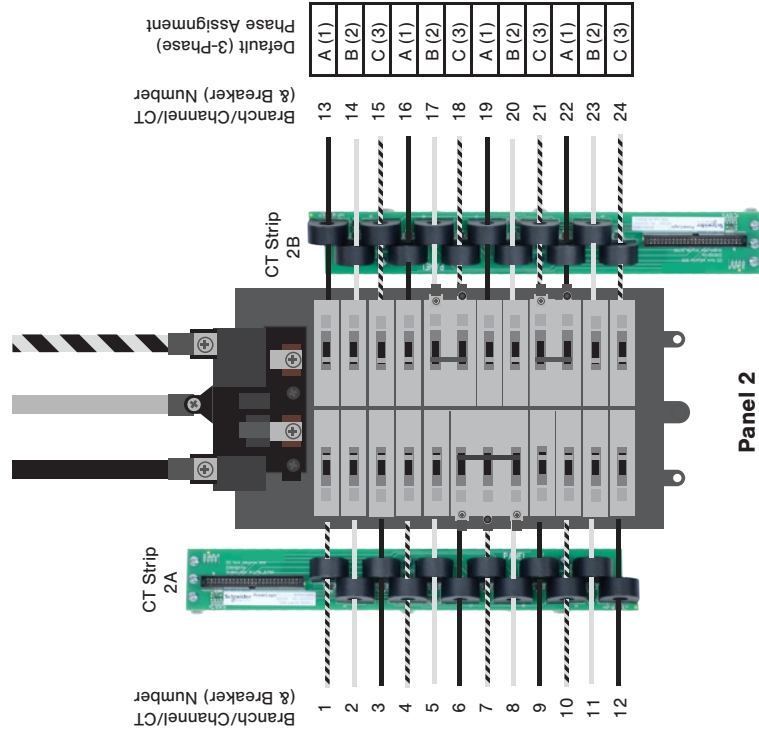

Panel 2
 Set Configuration
 (Modbus Register 6)
 to Sequential (2)

#11

Top of Panels ↑

36/72-ch Dual-Row
Sequential Configuration
Panel 1

Default (3-Phase)	A (1)
Phase Assignment	B (2)
	C (3)
Branch/Channel/CT (& Breaker) Number	1
	2
	3
	4
	5
	6
	7
	8
	9
	10
	11
	12
	13
	14
	15
	16
	17
	18

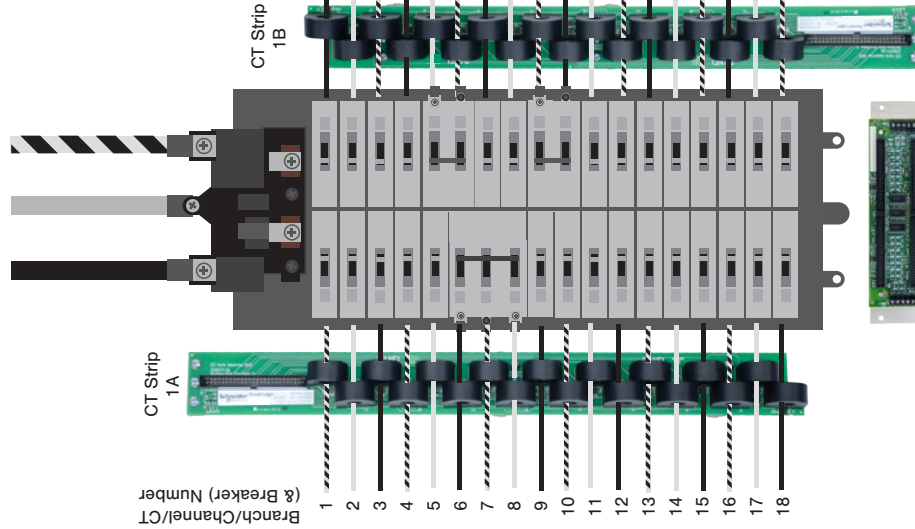

Panel 1
Set Configuration
(Modbus Register 6)
to Sequential (2)

72-ch Dual-Row
Sequential Configuration
Panel 2

Default (3-Phase)	A (1)
Phase Assignment	B (2)
	C (3)
Branch/Channel/CT (& Breaker) Number	1
	2
	3
	4
	5
	6
	7
	8
	9
	10
	11
	12
	13
	14
	15
	16
	17
	18

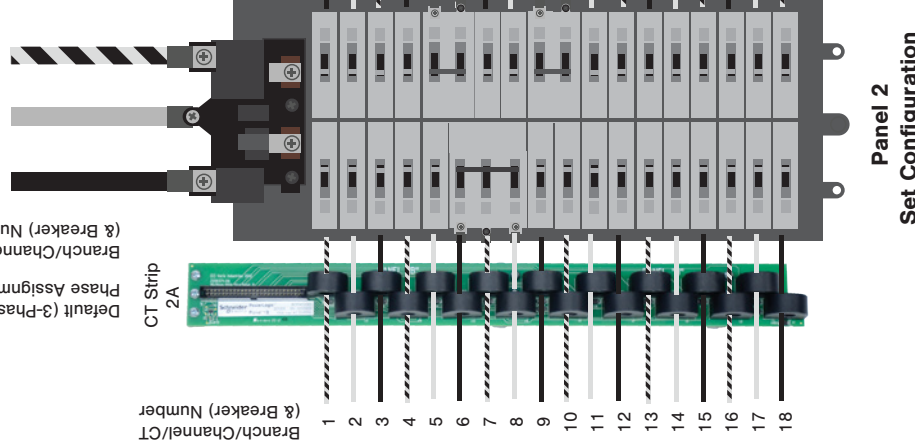

Panel 2
Set Configuration
(Modbus Register 6)
to Sequential (2)

Default (3-Phase)	A (1)
Phase Assignment	B (2)
	C (3)
Branch/Channel/CT (& Breaker) Number	19
	20
	21
	22
	23
	24
	25
	26
	27
	28
	29
	30
	31
	32
	33
	34
	35
	36

#12

Top of Panels ↑

42/84-ch Bottom Feed Configuration
 Panel 1

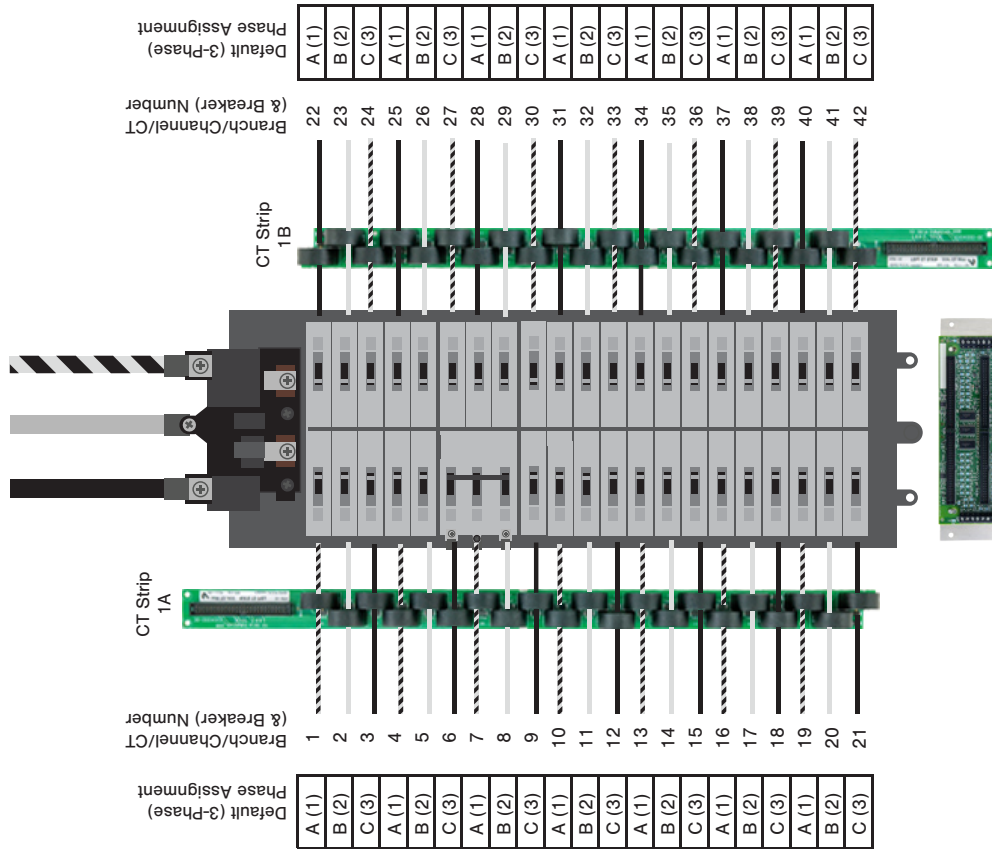

Panel 1
 Set Configuration
 (Modbus Register 6)
 to Top (0)

84-ch Bottom Feed Configuration
 Panel 2

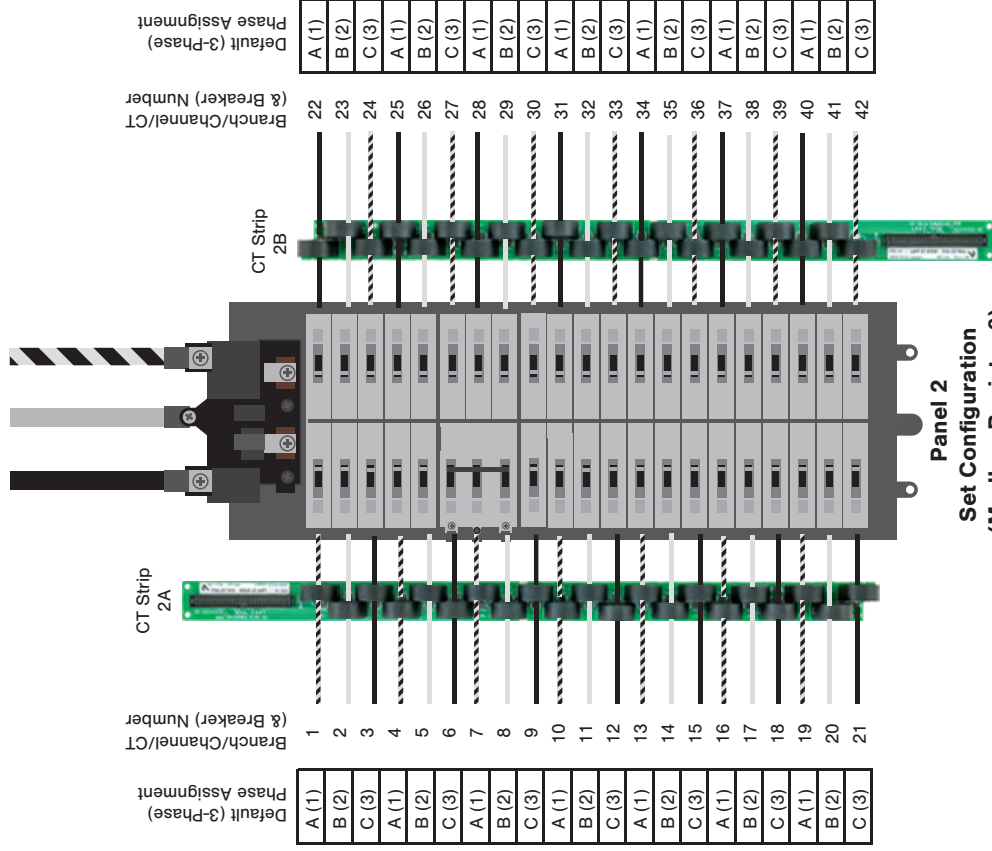

Panel 2
 Set Configuration
 (Modbus Register 6)
 to Top (0)

#13

Top of Panel ↑

48-ch Dual-Row Large Panel Sequential Configuration Panel 1

48-ch Dual-Row Large Panel Sequential Configuration Panel 2

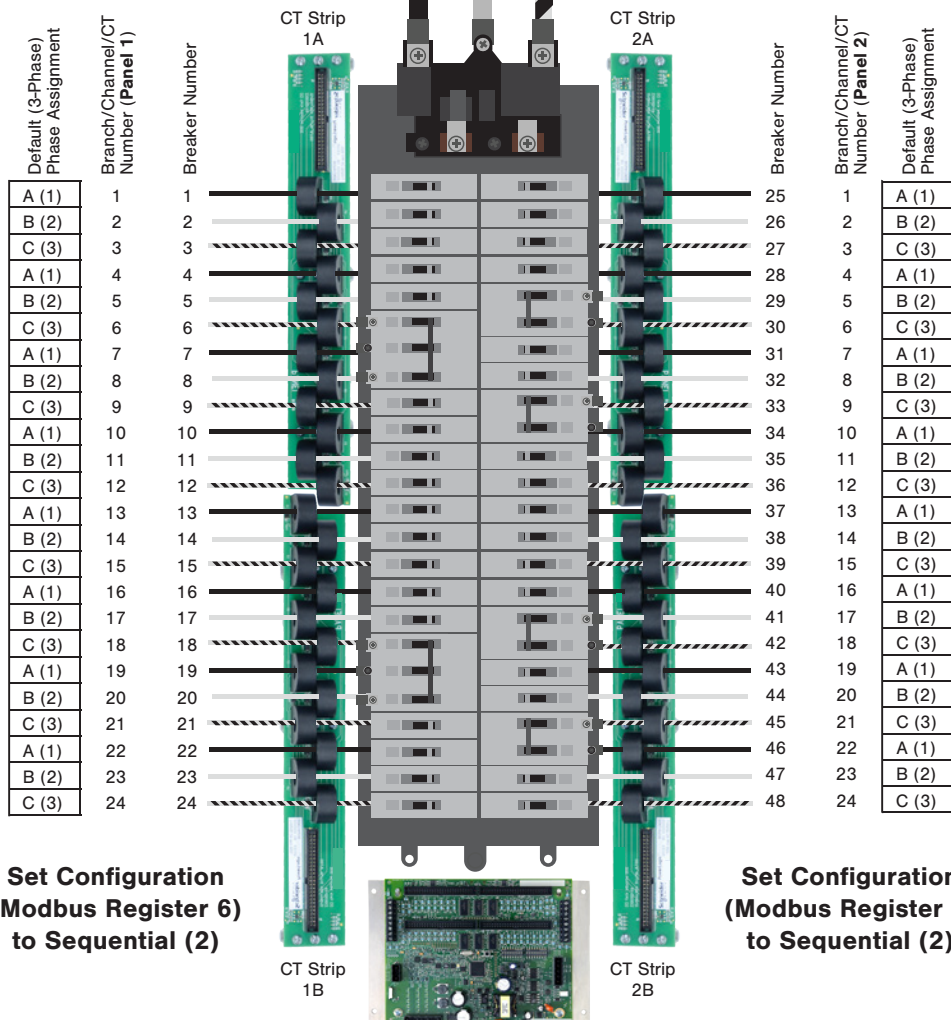

#14

Top of Panels ↑

72-ch Dual-Row Large Panel
 Sequential Configuration
 Panel 1

72-ch Dual-Row Large Panel
 Sequential Configuration
 Panel 2

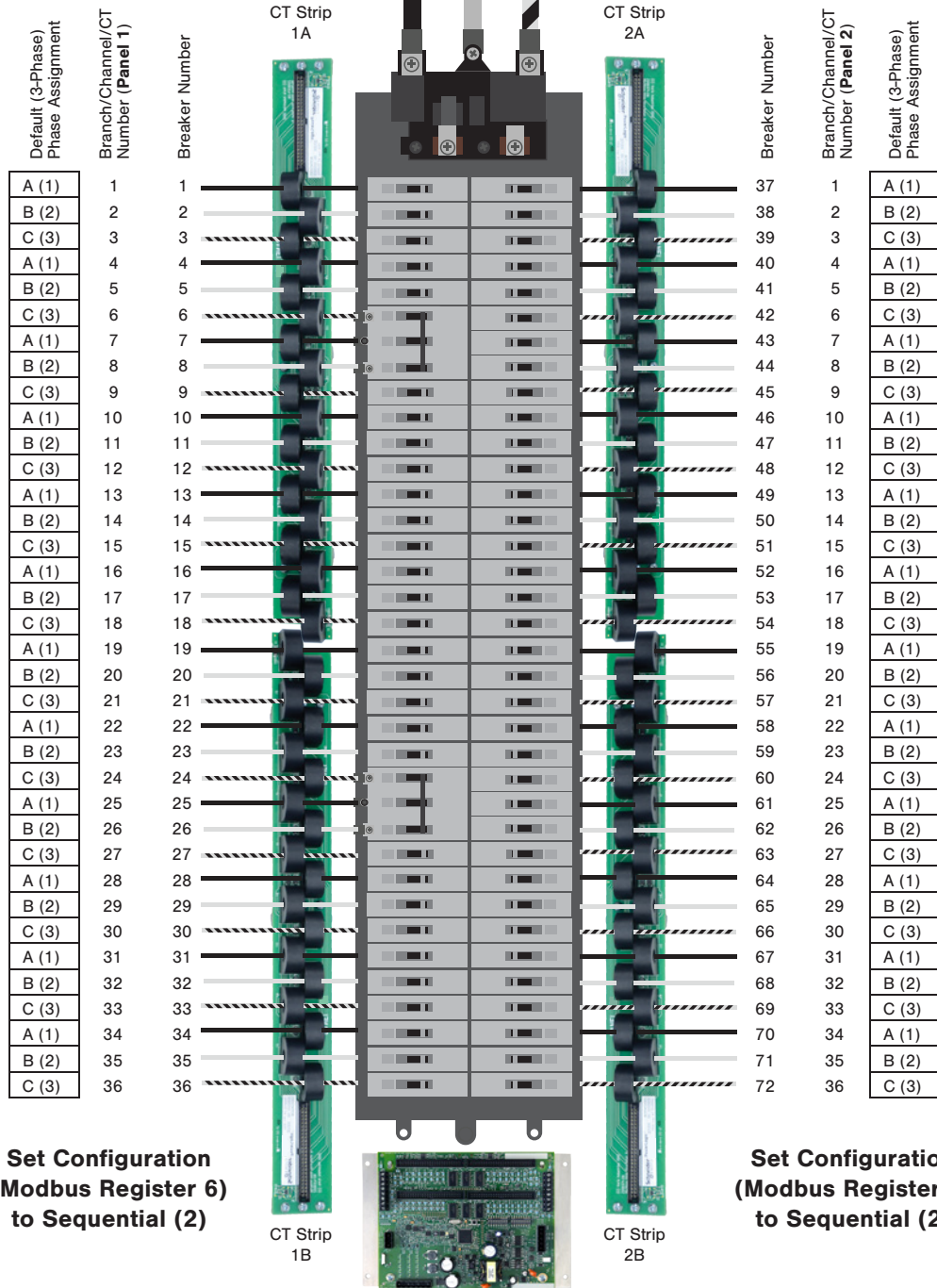

#15

Top of Panel ↑

**84-ch Dual-Row Large Panel
Sequential Configuration
Panel 1**

**84-ch Dual-Row Large Panel
Sequential Configuration
Panel 2**

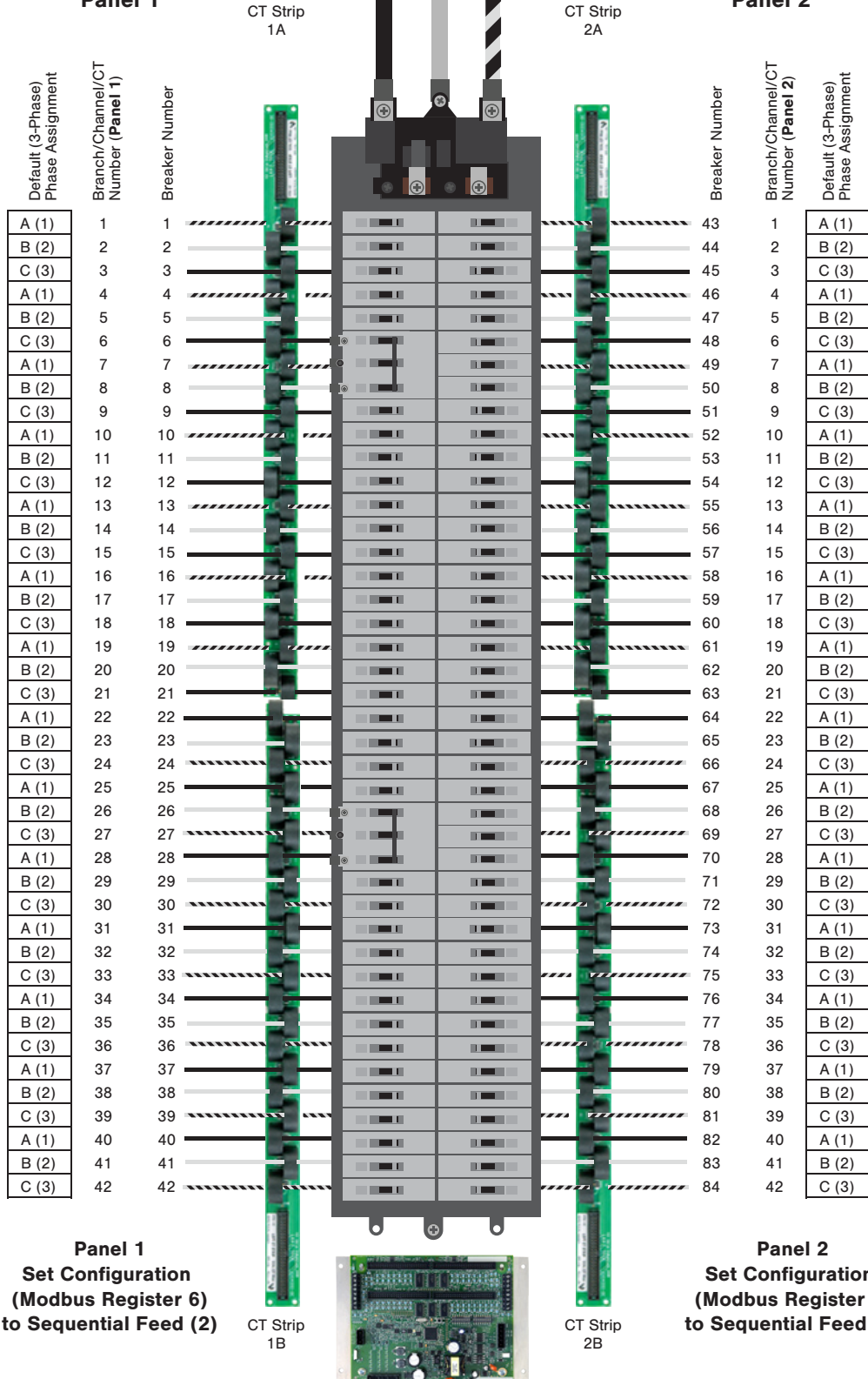

#16

Top of Panel ↑

24-ch Single-Row
 Sequential Configuration

Set Configuration
 (Modbus Register 6)
 to Sequential (2)

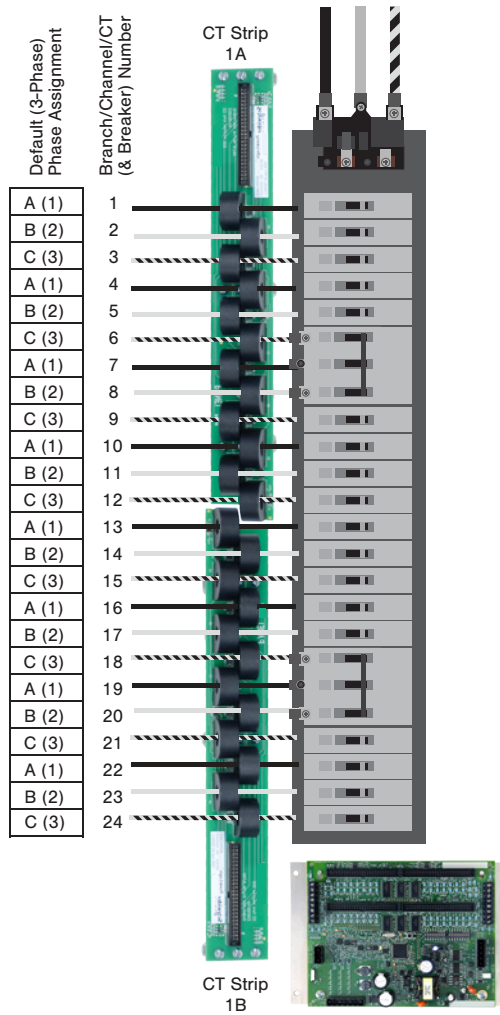

#17

Top of Panel ↑

36-ch Single-Row
 Sequential Configuration

Set Configuration
 (Modbus Register 6)
 to Sequential (2)

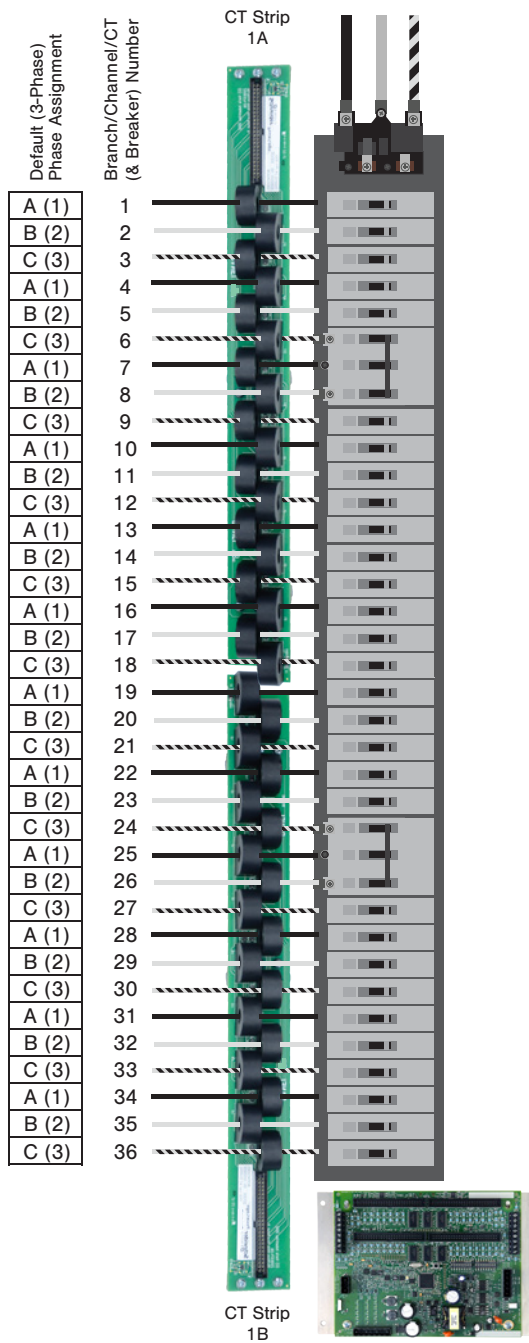

#18

Top of Panel ↑
**42-ch Single-Row
 Sequential Configuration**

**Set Configuration
 (Modbus Register 6)
 to Sequential (2)**

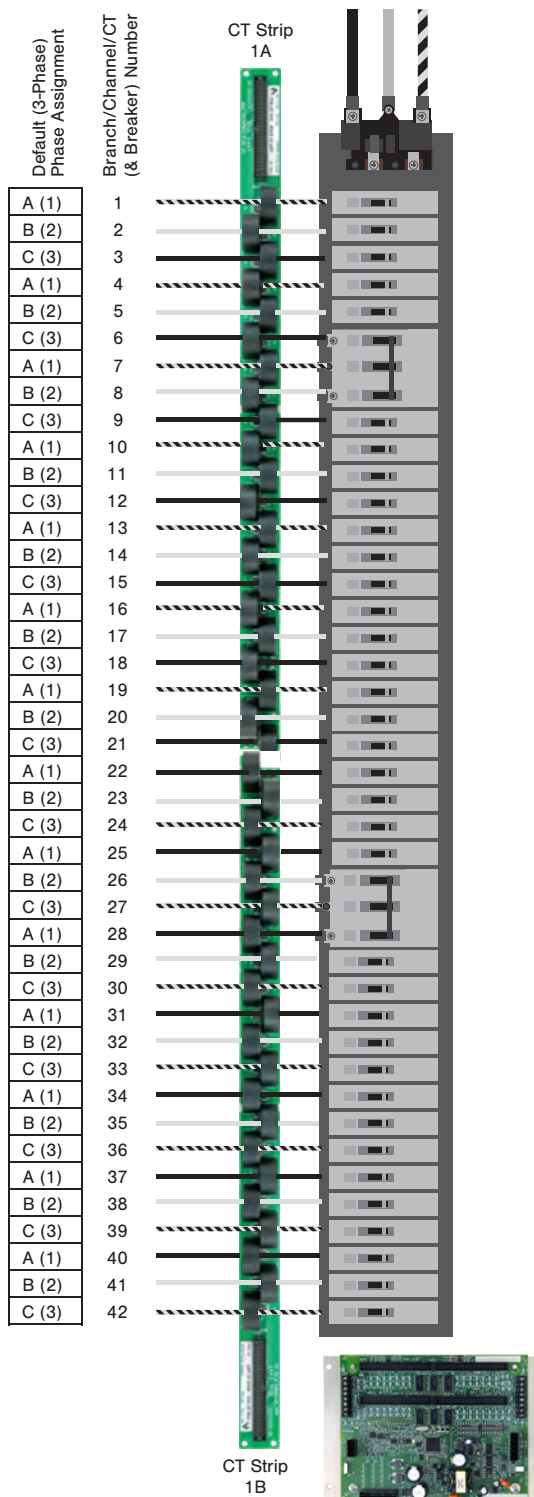

#19

Top of Panel ↑

42-ch Odd/Even Configuration

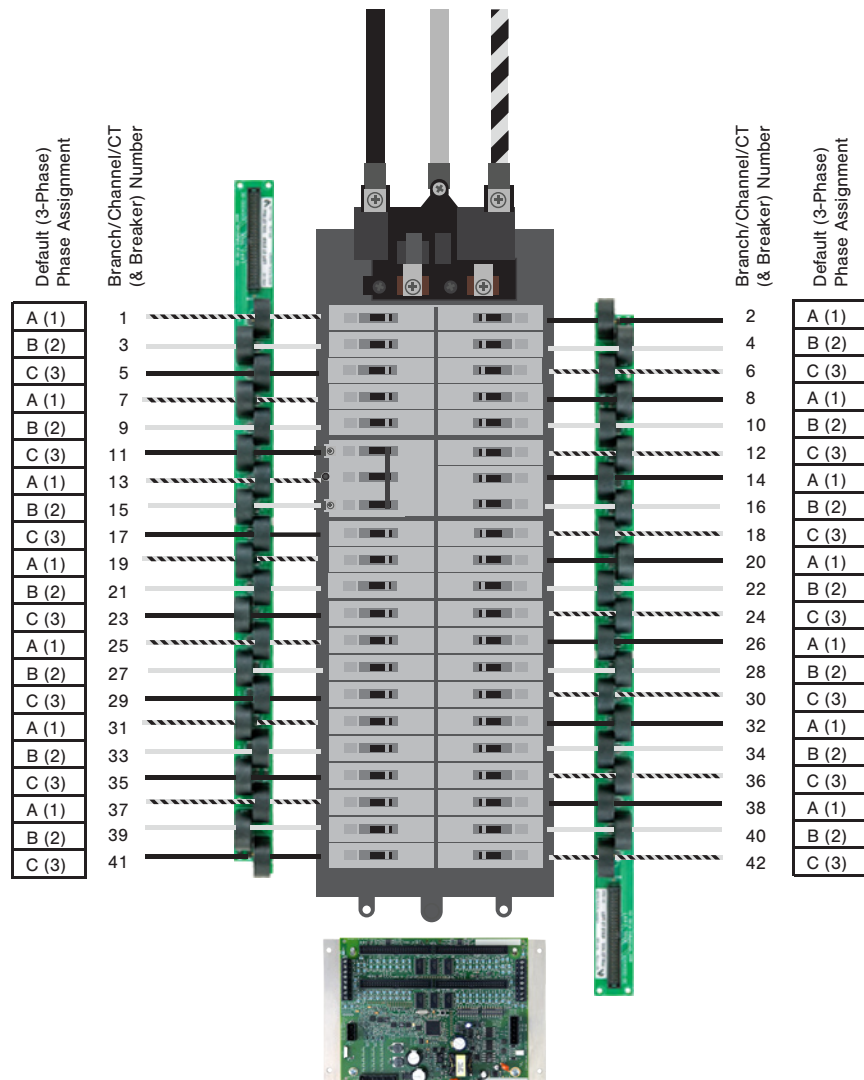

Panel 1
 Set Configuration
 (Modbus Register 6)
 to Odd/Even (3)

#20

Top of Panel ↑

24-ch Sequential Configuration

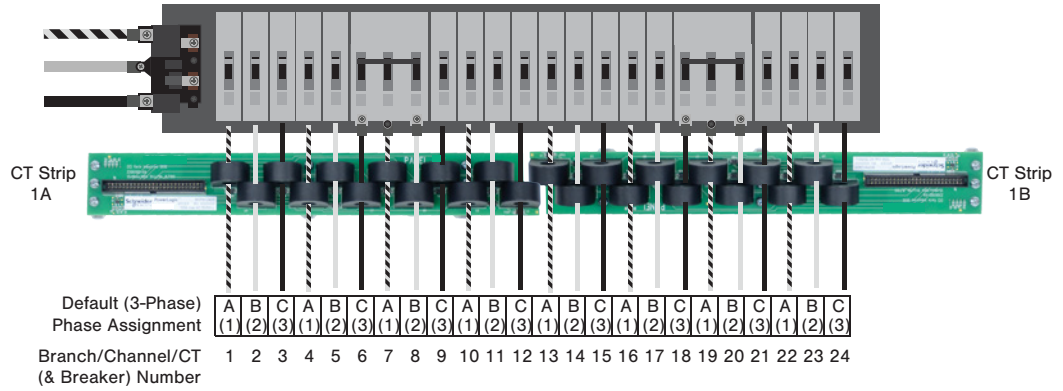
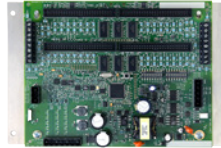

**Panel 1
 Set Configuration
 (Modbus Register 6)
 to Sequential (2)**

#21

Top of Panel ↑

36-ch Sequential Configuration

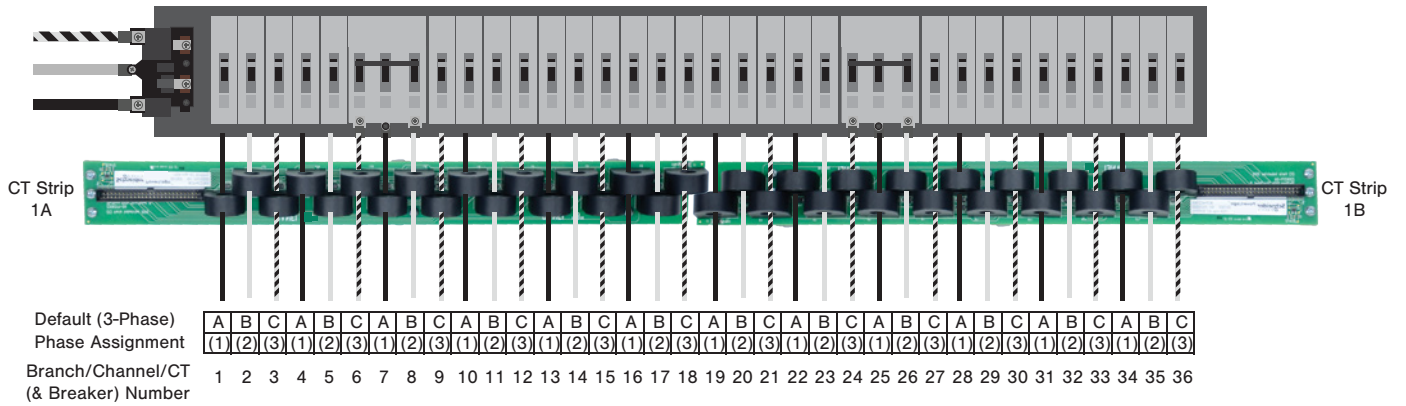

Panel 1
Set Configuration
(Modbus Register 6)
to Sequential (2)

#22

Top of Panel ↑

42-ch Sequential Configuration

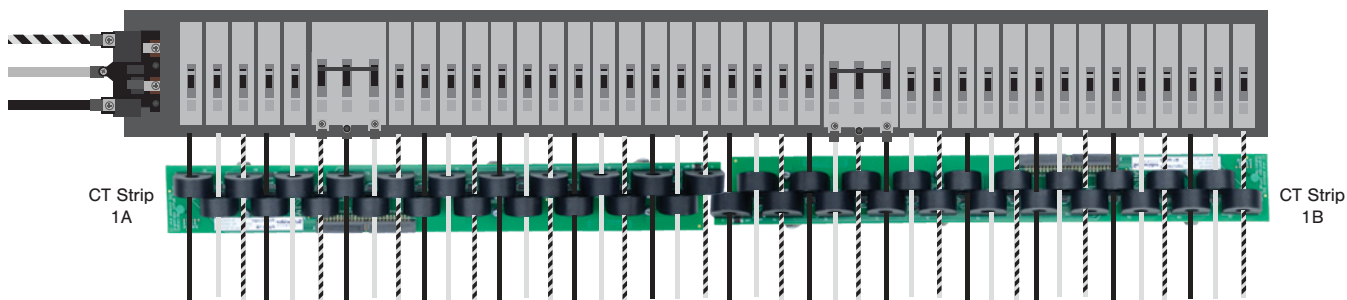
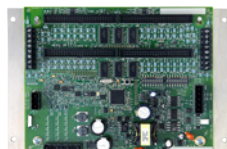

Default (3-Phase)	A	B	C	A	B	C	A	B	C	A	B	C	A	B	C	A	B	C	A	B	C	A	B	C	A	B	C	A	B	C	A	B	C	A	B	C	A	B	C			
Phase Assignment	(1)	(2)	(3)	(1)	(2)	(3)	(1)	(2)	(3)	(1)	(2)	(3)	(1)	(2)	(3)	(1)	(2)	(3)	(1)	(2)	(3)	(1)	(2)	(3)	(1)	(2)	(3)	(1)	(2)	(3)	(1)	(2)	(3)	(1)	(2)	(3)	(1)	(2)	(3)			
Branch/Channel/CT (& Breaker) Number	1	2	3	4	5	6	7	8	9	10	11	12	13	14	15	16	17	18	19	20	21	22	23	24	25	26	27	28	29	30	31	32	33	34	35	36	37	38	39	40	41	42

Panel 1
Set Configuration
(Modbus Register 6)
to Sequential (2)

#23

Top of Panels ↑

24-ch Dual-Row Sequential Configuration

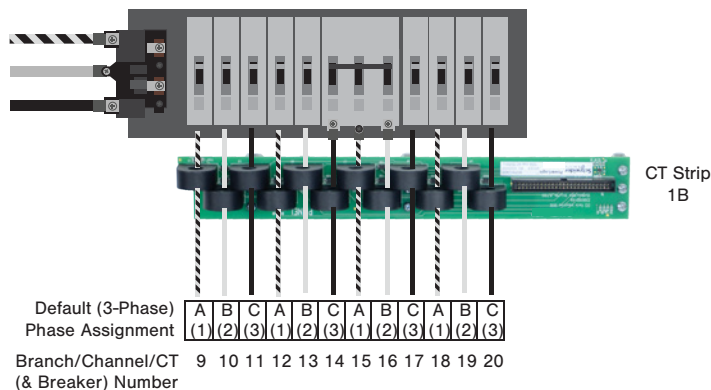
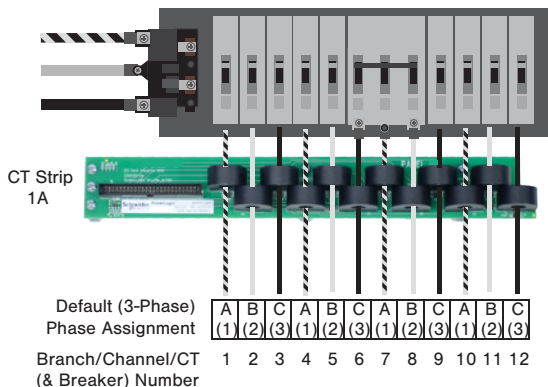

Panel 1
Set Configuration
(Modbus Register 6)
to Sequential (2)

#24

Top of Panels ↑

36-ch Dual-Row
Sequential Configuration

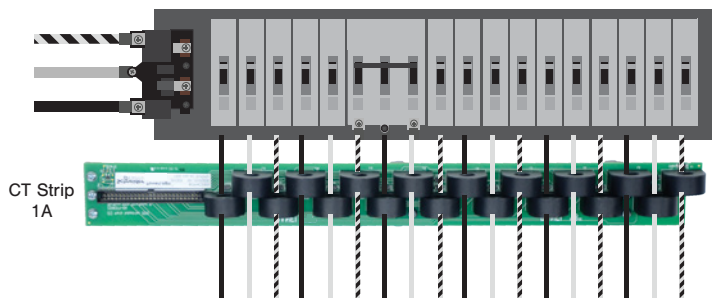

Default (3-Phase) Phase Assignment	A	B	C	A	B	C	A	B	C	A	B	C	A	B	C	A	B	C
	(1)	(2)	(3)	(1)	(2)	(3)	(1)	(2)	(3)	(1)	(2)	(3)	(1)	(2)	(3)	(1)	(2)	(3)
Branch/Channel/CT (& Breaker) Number	1	2	3	4	5	6	7	8	9	10	11	12	13	14	15	16	17	18

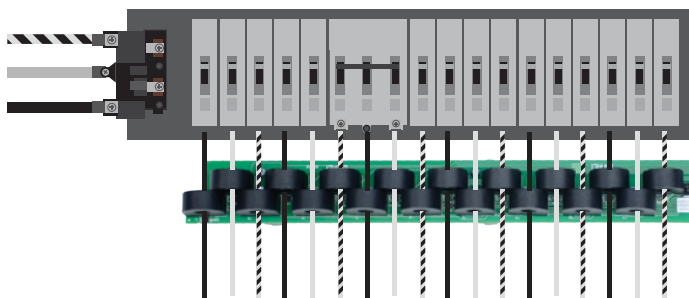

Default (3-Phase) Phase Assignment	A	B	C	A	B	C	A	B	C	A	B	C	A	B	C	A	B	C
	(1)	(2)	(3)	(1)	(2)	(3)	(1)	(2)	(3)	(1)	(2)	(3)	(1)	(2)	(3)	(1)	(2)	(3)
Branch/Channel/CT (& Breaker) Number	19	20	21	22	23	24	25	26	27	28	29	30	31	32	33	34	35	36

Panel 1
Set Configuration
(Modbus Register 6)
to Sequential (2)

#25

Top of Panels ↑

42-ch Dual-Row Sequential Configuration

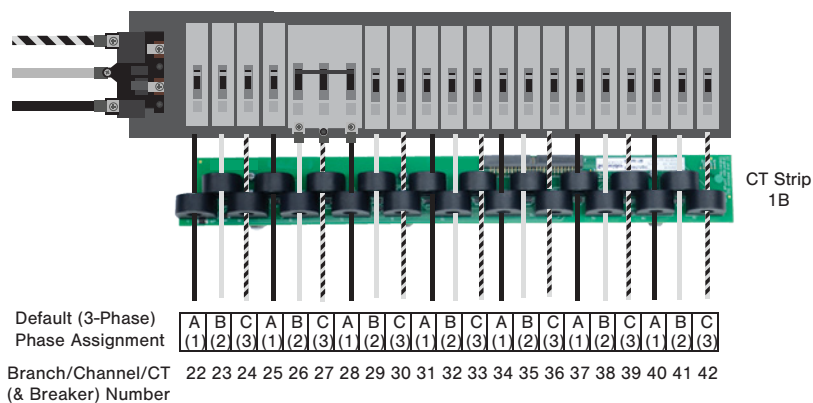
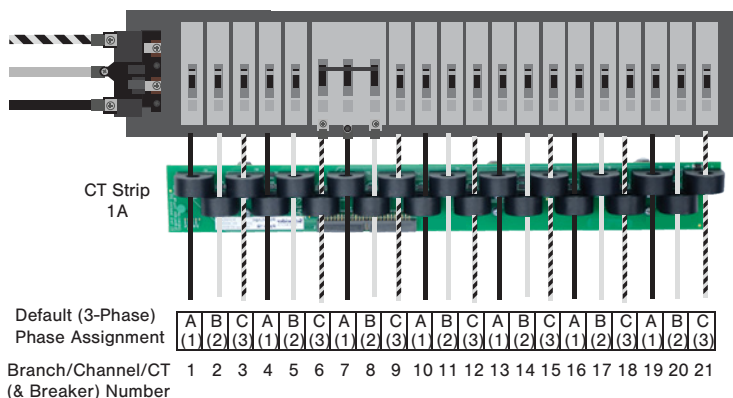

Panel 1 Set Configuration (Modbus Register 6) to Sequential (2)

#26

Top of Panels ↑

48-ch Dual-Row Sequential Configuration

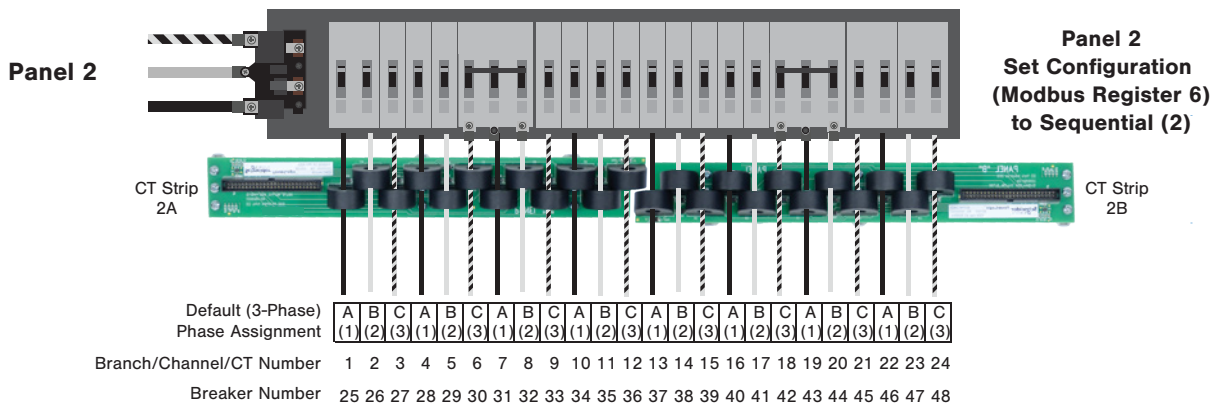
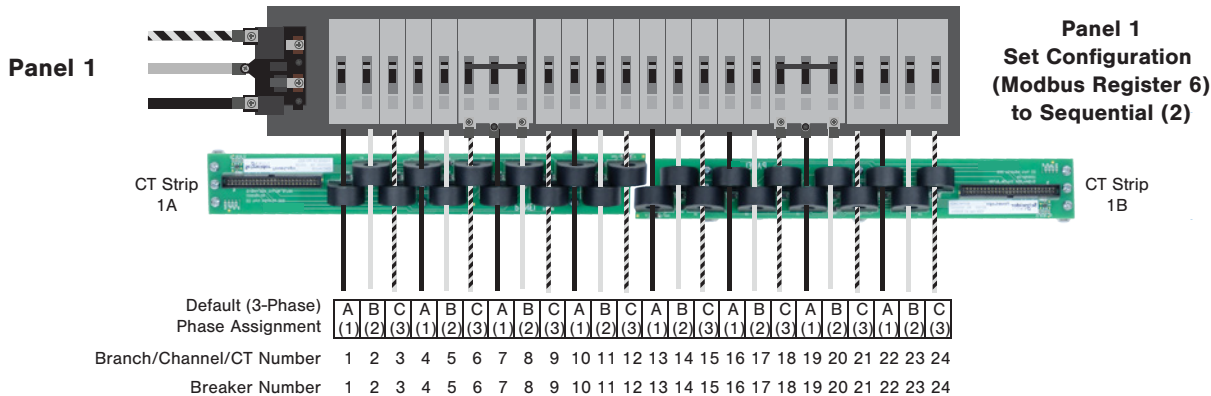

#27

Top of Panels ↑

72-ch Dual-Row Sequential Configuration

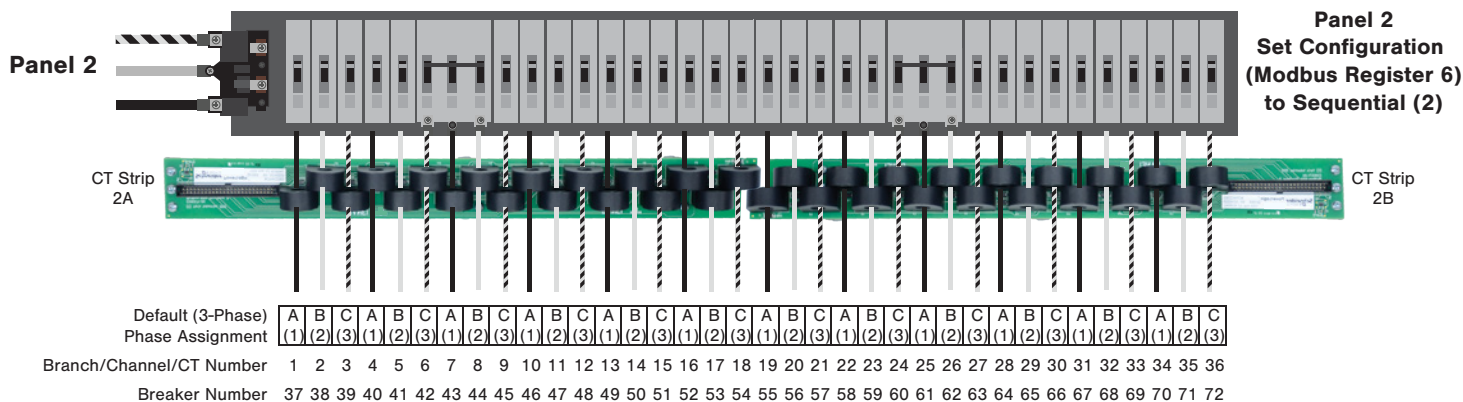
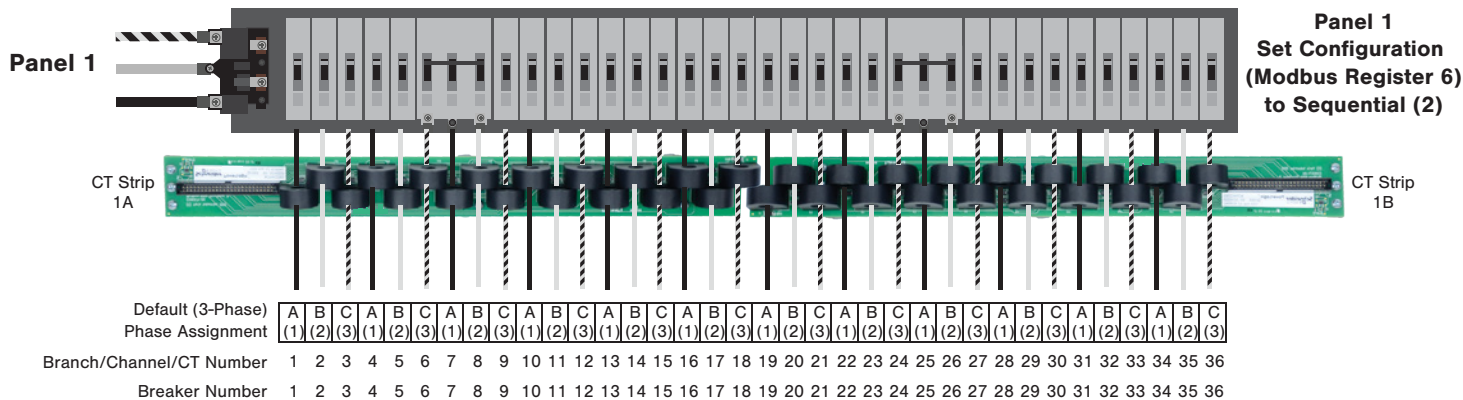

#28

Top of Panels ↑

84-ch Dual-Row
Sequential Configuration



Panel 1
Set Configuration
(Modbus Register 6)
to Sequential (2)

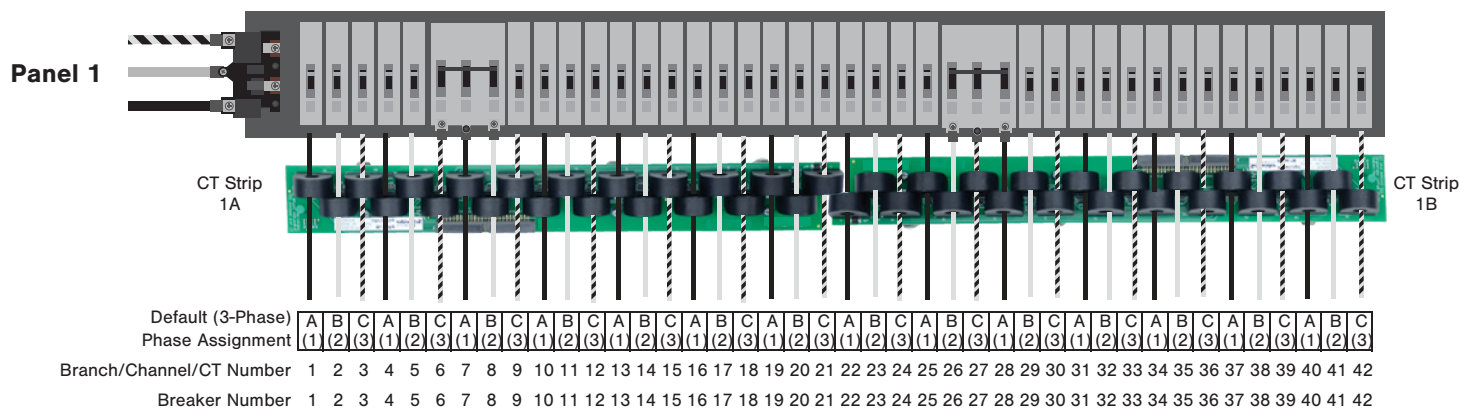

Panel 2
Set Configuration
(Modbus Register 6)
to Sequential (2)

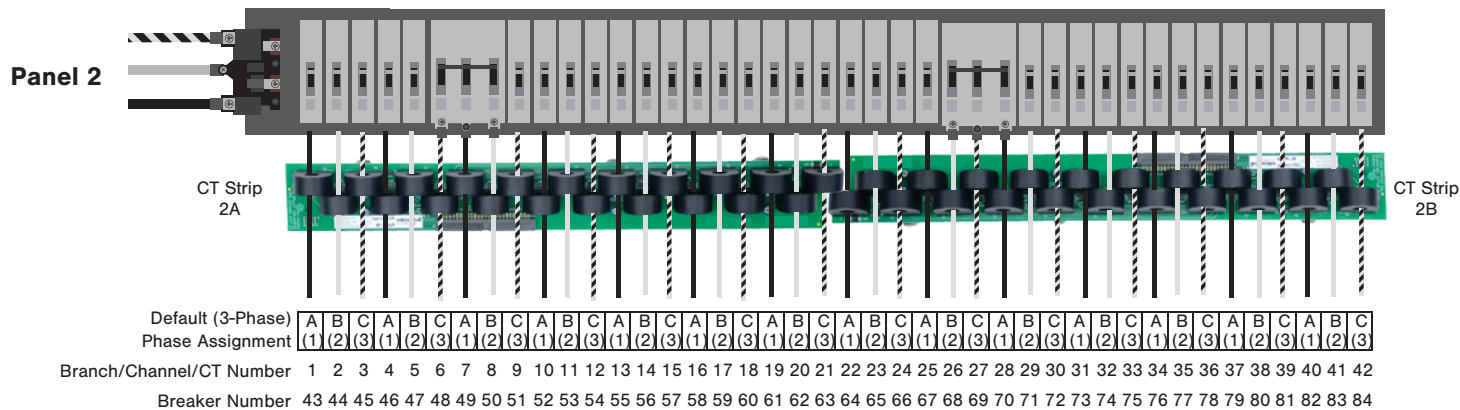

Schneider Electric
35, rue Joseph Monier
CS 30323
F - 92506 Rueil Malmaison Cedex
www.schneider-electric.com

As standards, specifications, and designs change from time to time, please ask for confirmation of the information given in this publication.

© 2016 Schneider Electric. All Rights Reserved.

Z205396-0K 08/2016