

PowerLogic™
AccuSine+

Catalogue 2021

Active Power Correction Solution

Harmonic compensation | Electronic VAR control |
Load balancing



FROST & SULLIVAN

BEST
2020 PRACTICES
AWARD

GLOBAL ACTIVE HARMONIC FILTERS/POWER
QUALITY PRODUCT LEADERSHIP AWARD

se.com/accusine

Life Is On

Schneider
Electric



FROST & SULLIVAN

BEST
2020 PRACTICES
AWARD

GLOBAL ACTIVE HARMONIC FILTERS/POWER
QUALITY PRODUCT LEADERSHIP AWARD

Schneider Electric Repeats Win for AccuSine+ Innovation

Frost & Sullivan's 2020 Global Product Leadership Award

The AccuSine+ platform continues to bring industry accolades. For the second time, Schneider Electric is the winner of the coveted 2020 Frost & Sullivan Award. The flagship product captured top honors in Global Product Leadership for its high-performance, technologically advanced range of AccuSine+ power correction solutions.

Winning the award demonstrates Schneider Electric's exceptional commitment to innovation, with the AccuSine+ platform bringing premium refinement, flexible designs and ultra-fast, highly accurate harmonic cancellation and reactive current compensation for power quality management.

As a provider of competitive and innovative products, Schneider Electric tailors its operations to meet customer requirements with the gold standard of products and services. The company services the global market for power correction where reliability, availability, scalability, efficiency, cost, and control are critical.



“

To drive value for its customers, the Schneider Electric considers the obstacles of installation, operations, and commissioning and translates its findings into frequent innovation that reflects customer needs and simplifies power quality management. The company builds intelligence into all of its products, designing them to be easy to install, use, and commission. This intelligence enables users to achieve their goals efficiently and effectively while minimizing disruption.

Jeffrey Castilla | Best Practices Research Analyst | Frost & Sullivan

Learn more at se.com/power-quality

Active Harmonic Compensation Offer

AccuSine PCSn

Technical Specifications.....	6
Selection Table.....	8
Rack System and Accessories.....	9

AccuSine PCS+

Technical Specifications.....	10
Selection Table.....	12

Electronic VAR Control Offer

AccuSine PFV+

Technical Specifications.....	14
Selection Table.....	16

Dimensions and Installation Guidelines

Unit Dimensions and Installation Guidelines for AccuSine PCSn.....	18
Unit Dimensions and Installation Guidelines for AccuSine PCS+ and AccuSine PFV+.....	20

Current Transformers and Accessories

Split Core Design.....	23
Round Solid Core Design.....	24
Auxiliary and Summing Transformers.....	25
Shorting Terminal Switch and Parallel Connection Cables.....	26

Human Machine Interface (HMI)

Human Machine Interface (HMI).....	27
------------------------------------	----

Technical References

Power Quality.....	28
Rack Systems and Cooling.....	29

Power Quality



Power quality problems are one of the major causes of unscheduled downtime, equipment malfunction, and damage. Reliability and consistency of electricity supply are critical to businesses, from industrial plants, medical facilities, data centers to office buildings. When power quality is imperfect due to disturbances such as interruptions, voltage dips or harmonic pollution, your business suffers.

It is an area of growing concern for end users due to the frequency of occurrence and financial impact of issues: 30 – 40 percent of all unscheduled downtime today is related to power quality problems. In the industry sector, for example, the cost of poor power quality can reach four percent of annual turnover and is often equivalent to the total balance payable on a facility's energy bill.

A capital investment in power factor correction and harmonic filtering equipment can result in a healthy return of investment. This return depends on the utility's demand rate structure; production quality cost related to harmonics; the cost of downtime and interruptions due to voltage fluctuations in the distribution system.

Today, electrical installations are exposed to a great deal of power quality problems; 80 percent of these disturbances are typically generated by installed equipment. In industrial facilities, for example, such disturbances can be caused by non-linear loads like arc welders or variable speed drives, capacitor switching, or large motor starts. In commercial buildings, electronic equipment like computers, UPS, and servers may also generate additional power quality disturbances.

The other 20 percent of power quality disturbances come from the energy provider: even the most advanced transmission and distribution systems are not able to guarantee 100 percent energy availability. Even with 99.99 percent energy availability, the equivalent interruption time amounts to 52 minutes every year.



Where used by application

	Buildings			Industry							
	Retail	Commercial & building	Healthcare	Water wastewater	Food & beverage	Automotive	Metal, Minerals & Mining	Petro-chemical	Glass	Semiconductor	
AccuSine PCSn	Office loads, LED/CFL lights, escalators, lifts	Office loads, LED/CFL lights, escalators, lifts	Office loads, LED/CFL lights, medical equipment, escalators, lifts		Process & production lines						
AccuSine PCS+	HVAC loads	HVAC loads	HVAC loads, pumps & fans	Pumps & fans with/without backup generators	Process & production lines HVAC loads	Process & production lines	Process & heating	Process pumps	Process & heating	Process, heating & production lines pumps & fans	
AccuSine PFV+						PFC in harmonic rich & flicker control for dynamic environment.	PFC in harmonic rich & flicker control for dynamic environment.	PFC in harmonic rich & dynamic environment.	PFC in harmonic rich & dynamic environment.		

AccuSine solutions solve a wide range of power quality problems.

AccuSine PFV+ is an electronic VAR compensation (EVC) employing a multi-level IGBT technology with advanced control systems platform to perform leading or lagging power factor correction (PFC) and flicker mitigation. It is the ideal solution for PFC applications subject to high voltage distortion or subject to dynamic fast changing loads. It offers an ultra-fast response, is resonance free, and provides an infinite resolution of compensation compared to conventional PFC solutions.

AccuSine PCSn and AccuSine PCS+ are flexible, high performance solutions to stabilize electrical networks by providing harmonic mitigation and power factor correction, and load balancing.

AccuSine PCS+ is specifically designed for harsh electrical conditions, for heavy industrial applications including mission critical environments.

In addition to 3-phase mitigation, AccuSine PCSn has the ability to compensate for neutral harmonic currents, typically present in building and commercial environments where single-phase non-linear loads are present.



A complete solution, when, where, and how you want it

Schneider Electric power quality solutions include everything needed to ensure your power system is operating at its best. Our expertise ranges from power system monitoring and problem diagnosis, to engineering, installing, and supporting the precise power quality solution your facility needs to run at an optimal efficiency and cost.

The quality and performance you expect

All our power quality solutions provide an excellent return on investment because they are designed and manufactured by Schneider Electric, by using advanced manufacturing methods and premium materials. They are optimized to match your application needs and are engineered to provide superior performance.

Where used by function

	Phase harmonics	Neutral harmonics	Power factor correction	Mains current balancing	Volt – VAR support	Flicker	Environmental conditions
AccuSine PCS+	■		■	■		■	Harsh and heavy industrial
AccuSine PCSn	■	■	■	■			Commercial and light industrial
AccuSine PFV+			■	■	■	■	Harsh and heavy industrial

		Infrastructure				IT & Telco	Renewable	
Textile	Ski lift / Amusement park	Marine	Airport	Railway & Tunnels	Oil & Gas	Datacentre	Solar	Wind
Office loads, LED/CFL lights			Office loads, LED/CFL lights, baggage systems, escalators, CCR runway lights, navigation instruments	HVAC, office loads, LED/CFL lights		Load harmonics on UPS & SMPS from blade servers		
Process & heating, pumps & fans	Load harmonics on chair lift, PFC	Propellers, pumps & fans (VSD driven)	CCR runway lights, pumps & fans, HVAC, with/without backup generators	Pumps & fans	Drilling, pumping, processing	Load harmonics on UPS, cooling system and HVAC	CSP: solar mirrors (VSD driven)	Load harmonics from converter
	Flicker mitigation, dynamic VAR injection	Dynamic PF correction to improve generator prime mover efficiencies		Traction substation load balancing, PF correction, VAR support	Dynamic PF correction to improve generator prime mover efficiencies	Leading PF correction (for backup generators & UPS)	Voltage support via VAR injection (with or without process logic)	Hybrid VAR compensation (with process logic system)

Active Harmonic Compensation Offer

AccuSine PCSn

The Schneider Electric solution for active harmonic filtering in building and commercial installations.



AccuSine PCSn wall mount - main unit (CE version)

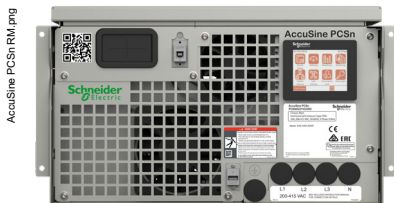

AccuSine PCSn rack mount - main unit (CE version)

AccuSine PCSn Technical Specifications

Electrical Characteristics

Standard RMS output current ratings	Chassis: 20 A, 30 A, 50 A, 60 A Wall: 20 A, 30 A, 50 A, 60 A Rack: 30 A, 60 A
Nominal voltage	208 - 415 Vac, -15%/+10%
Nominal frequency	50 / 60 Hz, ± 3 Hz auto sensing
Connection type	3ph/3wire or 3ph/4wire
Compensation type	3ph only or 3ph + Neutral
Earthing systems	TT, TN-C, TN-S, TN-C-S, IT, corner ground, centre-tapped delta, and HRG
Network voltage distortion	Max. 20% phase to phase (up to 30 th order)
Voltage notch limits	Notch depth: 10%, Notch area (A_N): 13,667 V μ s @ 400 V as per IEEE 519-2014, Annex C

Technical Product Characteristics

Power electronics	3-level IGBT
Control Topology	Digital harmonic FFT Digital instantaneous reactive power
Efficiency & Losses	208 Vac $\geq 95\%$ 3ph compensation: ≤ 17.7 W/A 3ph + N compensation: ≤ 19.7 W/A
	380 - 415 Vac $\geq 97\%$ 3ph compensation: ≤ 20.4 W/A 3ph + N compensation: ≤ 22.6 W/A
Current transformer	Any ratio with 1 A or 5 A secondary; Class 1.0 accuracy; 50/60 or 400 Hz rated (instrument rated or better); Grounded; can be shared with other devices.
CT VA loading	1 A: 0.04 VA 5 A: 1 VA
Quantity of CT	2 or 3 CTs for 3-phase loads 3 CTs are required for 4-wire with neutral connected loads
CT position	Grid or load sense
Control basis	Closed or open loop
Spectrum cancellation & selection	2 nd to 51 st harmonic order; discrete, fully selectable adjustable per harmonic order (amplitude % and ON/OFF).
Modes of operation	Multi-modes simultaneously or discrete - phase harmonic correction - neutral harmonic correction user-adjustable up to 3 time unit rating - power factor correction (cos ϕ) - mains current load balancing
Operational features	Current control (target THDi) Voltage control (target THDv) Reactive power control (target PF, target kvar)
Harmonic attenuation & filtering performance	THDi < 3% in closed loop control; max 20:1 THDi (typical reduction with load harmonic above 50% unit rating) Requires 3% or higher inductive impedance per non-linear load
Power factor correction	Optimize PF and Target PF (cos ϕ) programmable leading (capacitive) or lagging (inductive).
Mains current load balancing	Negative and zero sequence; selectable individually or simultaneously.
Resonance avoidance	Output at specific harmonic order turned off if resonance or lack of impedance detected or manually turned off.

Paralleling Characteristics

Scalability & Expandability	Upto 12 units in parallel per set of CT; any size unit combination possible (max n th order subject to network characteristics).
Parallel operation options	Master/Slave, Multi-master, Multi-master/Multi-slave (masters receive CT connection). Main units (master capable): 20 A, 30 A, 50 A, 60 A Expansion units (slave only - no CT connection): 60 A
Paralleling architecture	Distributed redundancy with no independent controller required.
Parallel sequence options	Load share: all operating units function at the same output percentage. Cascade: lead/lag with unit rotation; one unit operates to full capacity before next unit turns on; timed rotation.
Unit ID assignment	Automatic parallel ID assignment capability or can be set manually.

Active Harmonic Compensation Offer

AccuSine PCSn



AccuSine PCSn wall mount - main unit (UL version)

AccuSine PCSn Technical Specifications

Parallel redundancy	Any unit with CT connections will automatically become master if the controlling master is taken offline. Automatic increase in output of all units to make up capacity of any offline unit.
Parallel HMI control	The main unit permits viewing and changing parameter settings of the complete system or any other unit in the parallel system.

Control and Communications

Parallel communications	Proprietary communication bus between operating units (shielded CAT5e or higher required with RJ-45 connectors).
Control response time	40 - 60 μ s typical
Harmonic correction time	≤ 2 cycles
Reactive correction time	$\leq 1/2$ cycle
Communications protocol	Main units: Modbus RTU and Modbus TCP/IP Expansion units: Modbus RTU
Discrete I/O	4 inputs, 4 outputs assignable

Environmental Conditions

Operating temperature	0 °C to +45 °C (full performance, continuous operation without derating). Derate 2% per °C up to +50 °C
Relative humidity	0 - 95%, noncondensing
Operating altitude	1000 m (full performance, continuous operation). Derate 1% per 100 m above. Above 3000 m requires solid ground. Absolute max altitude: 4800 m.
Ambient temperature safety	Automatic temperature roll back based upon real-time over temperature monitoring. Absolute shutdown if air inlet temperature reaches +51 °C.
Preset output limits (rms)	Programmable set limit due to altitude or ambient temperature - becomes fixed output limit.
Storage (in original shipping packaging)	Temperature: -20 °C to +60 °C, Relative humidity: to 95 %, noncondensing, clean, dry, and protected. No conductive particles permitted.
Contaminant Levels - operating (IEC 60721-3-3)	Chemical Class 3C2, Mechanical Class 3S2 No conductive particles permitted.
Contaminant levels - transport and storage (IEC 60721-3-3)	Chemical Class 3C3, Mechanical Class 3S3 (stored in original shipping packaging). No conductive particles permitted.

Standards and Certification

Design reference	IEC 62477-1, IEC 61439-1, EN 61000-6-2, EN 61000-6-4 Class A, ISO 9001, IEE Std 519-2014, UL-508
EMC compliance	EN 61000-6-4 Class A (Emissions), EN 61000-6-2 (Immunity).
Seismic compliance	IBC 2015, ICC-ES AC156 ($S_{ps} = 2.47$ g) excluding UL Type 1 model.
Product certification	CE, $c_{UL_{us}}$ (UL508, CSA 22.2 No.14), RCM, EAC, ABS, DNV-GL

Mechanical and Installation Characteristics

Mounting configuration	Indoor Vertical: chassis and wall mount. Horizontal: 19" rack mount Floor standing possible using chassis unit.
Ingress protection	Chassis mount: IP00, Wall mount: IP20, UL Type 1, Rack mount: IP20
PCBA protection	Conformal coating on all PCBAs. Pollution degree 2.
Incoming circuit protection	None - supplied by others external to AccuSine PCSn unit (refer to AccuSine PCSn installation manual for further information). Recommended earth leakage protection: 500 mA
Cable entry	Chassis and wall mount: bottom entry Rack mount: front entry
Cooling configuration	Variable speed controlled forced ventilation. High heat plenum. Air flow: 560 m ³ /hr (329 cfm) Chassis and wall mount: bottom to top Rack module: front to back No conductive particles permitted, no corrosive gases.
Noise level	63 dB(A) typical
Dimensions (H x W x D) mm	Chassis and wall mount: 960 x 440 x 265 mm; Wall mount UL Type 1: 1440 x 445 x 265 mm Rack mount: 265 x 440 x 960 mm (6 U) (1 U = 1.75" = 44.45 mm)
Colour and material	Galvanized steel enclosure Wall & rack mount front door and grill: Powder coated Lt. grey RAL7035

AccuSine PCSn

AccuSine PCSn Technical Specifications

HMI and Service Provisions

Display	Magelis STU HMI, high definition color touchscreen TFT QVGA 64 k
Operator interface	Chassis mount: 144 mm (5.7") supplied for mounting remotely Wall mount: 144 mm (5.7") Rack mount: 90 mm (3.5") Expansion units: no HMI required
User interface options	Plain language, no cryptic code. Multiple languages: English, French, Spanish, Portuguese, Chinese, Korean, German, Russian, and Polish.
Service port	2 x USB ports for firmware update, diagnostics file, and event log download, connection to PC. Diagnostics can be downloaded via PC even if the unit is de-energized.
Commissioning features	On-board step-by-step commissioning wizard via HMI. On-board commissioning report for download - no additional software required. Automatic CT calibration, polarity detection and correction. Phase sequence unsusceptible. Automatic unit neutral connection check.

Interoperability and Integration

Floor standing enclosures	Using chassis module, ensuring air flow requirement is met.
Rack system integration	Suitable for 19" wide rack systems, ensuring rack density requirement is met.
Edge control EPMS / SCADA integration	EcoStruxure™ Power ready; native driver to Power Monitoring Expert 8.2 and later releases Compatible for operation with AccuSine PCS+/PFV+ range; Suitable for integration in 3 rd party EPMS/SCADA through modbus mapping.

Typical Applications



Building



LED / CFL loads



Research and Life Sciences



Commercial Retail



Hotel and Casino



Healthcare

- Airport terminal
- Railway terminal
- University facilities and accommodation
- Hospital

- Casino
- Datacentre SMPS loads
- Commercial space SMPS loads
- LED and CFL loads

Selection Table

AccuSine PCSn 208-415 V, 50/60 Hz

Rated current (A)	Neutral rated current (A)	Rated kVAR @ 415 V	Catalogue number	Ingress Protection	Mounting type	Unit type	Cable entry	Frame	Mass (kg)
20	60	14	PCSN020Y4CH00	IP00/Type OPEN*	Chassis	Main	Bottom	12	61
30	90	22	PCSN030Y4CH00	IP00/Type OPEN*					
50	150	36	PCSN050Y4CH00	IP00/Type OPEN*		Expansion			75
60	180	43	PCSN060Y4CH00	IP00/Type OPEN*					
60	180	43	PCSN060Y4CH00E	IP00/Type OPEN*					
20	60	14	PCSN020Y4W20	IP20	Wall mount	Main	Bottom	12	61
30	90	22	PCSN030Y4W20	IP20					
50	150	36	PCSN050Y4W20	IP20		Expansion			75
60	180	43	PCSN060Y4W20	IP20					
60	180	43	PCSN060Y4W20E	IP20					
20	60	14	PCSN020Y4N1	UL Type 1	Wall mount	Main	Bottom	13	74
30	90	22	PCSN030Y4N1	UL Type 1					
50	150	36	PCSN050Y4N1	UL Type 1		Expansion			89
60	180	43	PCSN060Y4N1	UL Type 1					
60	180	43	PCSN060Y4N1E	UL Type 1					
30	90	22	PCSN030Y4R19	IP20	19" rack mount	Main	Front	14	61
60	180	43	PCSN060Y4R19	IP20					
60	180	43	PCSN060Y4R19E	IP20		Expansion			75

*Note: UL Type OPEN models shall be installed with fuse kit (PCSNFUSKIT230 or PCSNFUSKIT560) on line side to maintain $c_{UL_{US}}$ compliance

AccuSine PCSn rack modules are designed to fit the NetShelter SX rack enclosures. Ready for high-density environments right out of the box, NetShelter SX rack enclosures offer the most common features on the market today. Recommended rack solutions and accessories are provided in the following table.

Active Harmonic Compensation Offer

Selection Table

Accessories and Rack Enclosure Systems					
Catalogue number	Description	Mass (kg)	Dimensions (mm)		
			Height	Width	Depth
AR3100	NetShelter SX 42U x 600 mm Wide x 1070 mm Deep with doors	125	1991	600	1070
AR3300	NetShelter SX 42U x 600 mm Wide x 1200 mm Deep with doors	134	1991	600	1200
AR8136BLK	NetShelter SX 1U toolless snap-in blanking panel, 10 pieces per pack	0.1	45	483	28
AR8108BLK	NetShelter SX 1U standard metal blanking panel, 2 pieces per pack	0.1	44	483	3
AR8101BLK	NetShelter SX 1U, 2U, 4U, 8U, blanking panel kit	3	-	483	3
AR7700	NetShelter SX stabilization plate to prevent tipping when sliding out equipment	4.5	75	351	207
AR7701	NetShelter SX bolt-down kit — meets IBC seismic requirements for moderate seismic zones	0.7	73	70	62
AR7701A-S	NetShelter SX bolt-down kit — meets IBC seismic requirements for high seismic zones	1	70	320	50
PCSNBTMKIT01	AccuSine PCSn terminal box for chassis & wall mount	7	430	550	290
PCSNFUSKIT230	AccuSine PCSn fuse kit for 20 A & 30 A chassis & wall mount	2	73	70	62
PCSNFUSKIT560	AccuSine PCSn fuse kit for 50 A & 60 A chassis & wall mount	2	70	320	50

For more information on NetShelter SX, please refer to: <http://www.se.com/en/product-category/7500-it-racks-and-accessories>

1U = 1.75" = 44.45 mm - Each PCSn rack module is 6U high + 1U space for cabling accessory (supplied with each unit).

Included in packaging: PCSn rack module, 1U cable plate and a pair of mounting rails for installation in NetShelter SX rack enclosures.

Note: Rack enclosure and accessories are not included in the PCSn module and must be ordered separately using the commercial references provided in the table above.

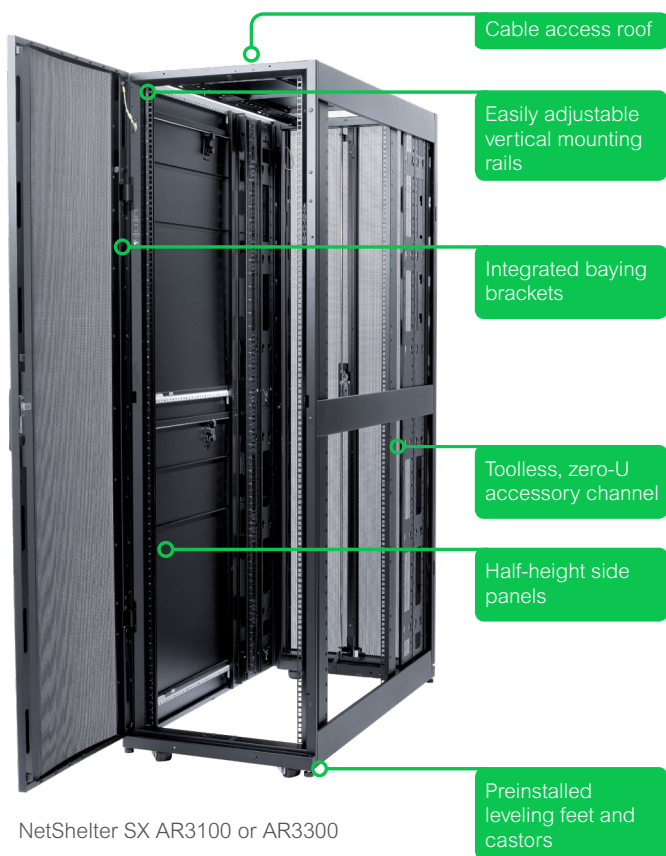

Air sealing: covers open space to prevent air recirculation and reduce bypass airflow to improve cooling efficiency.



Bolt-down and stabilization: prevents tip-over in stand-alone rack applications and meet specific anchoring requirements.



Active Harmonic Compensation Offer

AccuSine PCS+

Active harmonic filtering solution for industrial and heavy-duty applications.



Model 6 MCC (UL and CSA approved)



Okken / Blokset (IEC61439 certified)

AccuSine PCS+ Technical Specifications

Electrical characteristics

Standard RMS output current ratings	208 - 240 Vac: 60 A, 120 A, 200 A, 300 A 380 - 480 Vac: 60 A, 120 A, 200 A, 300 A 480 - 600 Vac: 47 A, 94 A, 157 A, 235 A 600 - 690 Vac: 40 A, 80 A, 133 A, 200 A
Nominal voltage	208 - 240 Vac, + 10% / -10% 380 - 480 Vac; + 10% / -15% 480 - 600 Vac; + 10% / -15% 600 - 690 Vac; + 10% / -15%
Nominal frequency	50 / 60 Hz, ± 3 Hz auto sensing
Connection type	3ph/3wire (neutral connection not required)
Compensation type	3ph only (for neutral compensation, use AccuSine PCSn)
Earthing systems	TT, TN-C, TN-S, TN-C-S, IT, corner ground, centre-tapped delta and HRG
Voltage notch limits	Notch depth: 20%, Notch area (AN): 22,800 V μ s @ 480 V (19,000 V μ s @ 400 V) as per IEEE 519-2014, Annex C

Technical Product Characteristics

Power electronics	3-level IGBT	
Control Topology	Digital harmonic FFT Digital instantaneous reactive power.	
Efficiency & Losses	208 - 480 Vac > 97% 600 - 690 Vac > 95%	400 Vac up to 97.7% (≤ 19.6 W/A) 480 Vac up to 97.8% (≤ 22 W/A)
Current transformers	Any ratio with 1 A or 5 A secondary Class 1.0 accuracy 50/60 or 400 Hz rated (Instrument rated or better) Grounded; can be shared with other devices.	
CT VA loading	1 A: 0.04 VA, 5 A: 1 VA	
Quantity of CT	2 or 3 for 3-phase loads 3 CTs are required if L-N connected loads are present	
CT position	Grid sense (at mains) or load sense	
Control basis	Closed or open loop	
Spectrum cancellation & selection	2 nd to 51 st harmonic order; discrete, fully selectable adjustable per harmonic order (amplitude % and ON/OFF)	
Modes of operation	Multi-modes simultaneously or discrete - phase harmonic correction - power factor correction (cos ϕ) - mains current load balancing	
Operational features	Current control (target THDi) Voltage control (target THDv) Reactive power control (target PF, target kvar)	
Harmonic attenuation & filtering performance	THDi < 3% in closed loop control; max 20: 1 THDi typical (reduction with load harmonic above 50% unit rating) requires 3% or higher inductive impedance per nonlinear load	
Power factor correction	Target PF (cos ϕ) programmable leading (capacitive) or lagging (inductive)	
Mains current load balancing	Negative sequence current	
Resonance avoidance	Output at specific harmonic order turned off if resonance or lack of impedance detected; or manually turned off	

Paralleling Characteristics

Scalability & Expandability	up to 10 units in parallel per set of CT; any size unit combination possible (max n th order subject to network characteristics) contact us for more than 10 units in parallel	
Parallel operation options	Master/slave, Multi-master, Multi-master/multi-slave (masters receive CT connection)	
Paralleling architecture	Distributed redundancy with no independent controller required.	
Parallel sequence options	Load Share: All operating units function at the same output percentage. Cascade: Lead/lag with unit rotation: one unit operates to full capacity before next unit turns on; timed rotation.	
Unit ID assignment	Automatic parallel ID assignment capability or can be set manually	
Parallel redundancy	Any unit with CT connections will automatically become master if the controlling master is taken offline. Automatic increase in output of all units to make up capacity of any offline unit.	
Parallel HMI control	Any main unit permits viewing and changing parameter settings of complete system or any other unit in parallel system	

Control & Communications

Parallel communications	Proprietary communication bus between operating units (shielded CAT5e or higher required with RJ-45 connectors)	
Control response time	25 μ s typical	
Harmonic correction time	≤ 2 cycles	
Reactive correction time	$\leq 1/4$ cycle	
Communications protocol	Modbus RTU & Modbus TCP/IP	
Discrete I/O	4 inputs, 4 outputs assignable	

AccuSine PCS+ Specifications

Environmental Conditions	
Operating temperature	Without derating - full performance, continuous duty 0 °C to +45 °C: 60 A, 120 A, 200 A (IP00/UL type Open and IP20/UL Type 1) 0 °C to +40 °C: all other models With derating - 2% per °C above +40 °C/+45 °C up to +50 °C max: all models
Relative humidity	0-95%, noncondensing
Operating altitude	1000m (full performance, continuous operation). Derate 1% per 100 m above Above 3000m requires solid ground. Absolute max altitude: 4800 m
Ambient temperature safety	Automatic temperature roll back based upon real-time over temperature monitoring. Absolute shutdown if air inlet temperature reaches +51 °C
Preset output limits (rms)	Programmable set limit due to altitude or ambient temperature - becomes fixed output limit
Storage (in original shipping packaging)	Temperature: -20 °C to +60 °C, Relative humidity: to 95 %, noncondensing Clean, dry, and protected. No conductive particles permitted.
Contaminant Levels - operating (IEC 60721-3-3)	Chemical Class 3C2, Mechanical Class 3S2 No conductive particles permitted
Contaminant levels - transport and storage (IEC 60721-3-3)	Chemical Class 3C3, Mechanical Class 3S3 (stored in original shipping packaging) No conductive particles permitted

Standards & Certification	
Design reference	IEC 62477-1, IEC 61439-1, EN 61000-6-2, EN 61000-6-4 Class A, ISO 9001, UL 508, IEEE Std 519-2014
EMC compliance	EN 61000-6-4 Class A (Emissions), EN 61000-6-2 (Immunity)
Seismic compliance	IBC 2015, ICC-ES AC156 (S _{DS} = 2.47 g) floor standing models require top constraint - use NSYSFWFIX.
Product Certification	CE, cUL _{US} (UL 508, CSA 22.2 No.14-18), CNAS, RCM, EAC, RoHS, ABS, DNV-GL

Mechanical & Installation Characteristics	
Mounting configuration	Indoor. Vertical: chassis & wall mount Free standing: floor standing enclosures
Ingress protection	Chassis (IP00) & Wall mount (IP20 / UL type 1) Floor standing enclosures (IP31, IP54, UL type 1, UL type 2, UL type 12)
PCBA protection	Conformal coating on all PCBAs. Pollution degree 2
Incoming circuit protection	Chassis & Wall mount: none, supplied by others external to equipment Floor standing models: to 240 Vac - 200 kA _{cUL_{US}} ; 150 kA IEC, to 415 Vac - 200 kA _{cUL_{US}} ; 125 kA IEC to 480 Vac - 200 kA _{cUL_{US}} ; 75 kA IEC, to 600 Vac - 100 kA _{cUL_{US}} ; 20 kA IEC to 690 Vac - No _{cUL_{US}} ; 100 kA IEC
Cable entry	Chassis & Wall mount: bottom entry Floor standing models: top and bottom entry through gland plates
Cooling configuration	Combination of natural and forced ventilation; separate air plenums for heat sink and PCBA sections. Heat sink plenum: inlet bottom, exhaust top. All internal components rated ≥ IP54 PCBA plenum: inlet bottom, exhaust top. Air supply must be clean and dry No conductive particles permitted, no corrosive gases
Noise level	< 70 dB(A) typical
Dimensions & Weight	see Selection table and Dimensions guidelines on following pages
Colour & material	Chassis & Wall mount: Galvanised steel Floor standing enclosures: Powder coated Lt. grey RAL7035

HMI & Service Provisions	
Display & Operator interface	Magelis STU HMI, 144 mm (5.7") high definition colour touchscreen TFT QVGA 64 k
User interface options	Plain language, no cryptic code. Multiple languages: English, French, Spanish, Portuguese, Chinese, Korean, Russian, Polish & German
Service port	2 x USB ports for firmware update, diagnostics file & event log download, connection to PC Diagnostics can be downloaded via PC even if unit is de-energised
Commissioning features	On-board step-by-step commissioning protocol via HMI On-board commissioning report for download - No additional software required Automatic CT calibration, polarity detection and correction Phase sequence unsusceptible

Interoperability and Integration	
iMCC integration	Validated design in Okken / Blokset
Custom enclosure integration	Using IP00 chassis to integrate in any custom enclosure
Edge control EPMS / SCADA integration	EcoStruxure™ Power ready Native driver to PME 8.2 and above Compatible for operation with AccuSine PCSn and AccuSine PFV+ ranges Suitable for integration in 3 rd party EPMS/SCADA through modbus mapping

Typical Applications



Oil and gas

- Oil and gas platforms
- Port cranes
- Steel
- Water/wastewater
- HVAC



Water



Cement



HVAC

- Automotive
- Process plants, pulp, and paper
- Wind and solar farms
- Lifts (ski or building)
- Marine vessels



Building



Wind turbines

Selection Table

AccuSine PCS+ 208 - 240 V, 50/60 Hz							
Rated current	KVAR rating @ voltage	Catalog number	Enclosure			Frame	Weight kg
			Rating	Style	Cable entry		
60	21.6 @ 208 24.9 @ 240	PCSP060D2IP00	IP00 (chassis)	Wall mount	Bottom	1	88
		PCSP060D2N2	UL Type 2	Floor standing	Top or Bottom	2	277
		PCSP060D2IP31	IP31				291
		PCSP060D2N12	UL Type 12				
		PCSP060D2IP54	IP54				
120	43.2 @ 208 49.9 @ 240	PCSP120D2IP00	IP00 (chassis)	Wall mount	Bottom	3	113
		PCSP120D2N2	UL Type 2	Floor standing	Top or Bottom	4	279
		PCSP120D2IP31	IP31				293
		PCSP120D2N12	UL Type 12				
		PCSP120D2IP54	IP54				
200	72.1 @ 208 83.1 @ 240	PCSP200D2IP00	IP00 (chassis)	Wall mount	Bottom	5	171
		PCSP200D2N1	UL Type 1	Floor standing	Top or Bottom	11	363
		PCSP200D2N2	UL Type 2			6	384
		PCSP200D2IP31	IP31				402
		PCSP200D2N12	UL Type 12				
		PCSP200D2IP54	IP54				
300	108.1 @ 208 124.7 @ 240	PCSP300D2IP00	IP00 (chassis)			Wall mount	Bottom
		PCSP300D2N1	UL Type 1	Floor standing	Top or Bottom	11	402
		PCSP300D2N2	UL Type 2			8	422
		PCSP300D2IP31	IP31				436
		PCSP300D2N12	UL Type 12				
		PCSP300D2IP54	IP54				

Note:

60 A IP20/UL Type 1 configuration requires ordering two items: PCSP060D2IP00 and PCSPWMKIT60A; adds 232 mm to IP00 length and 8.7 kg.
 120 A IP20/UL Type 1 configuration requires ordering two items: PCSP120D2IP00 and PCSPWMKIT120A; adds 232 mm to IP00 length and 9.3 kg.
 200 A IP20/UL Type 1 configuration requires ordering two items: PCSP200D2IP00 and PCSPWMKIT300A; adds 273 mm to IP00 length and 8.6 kg.
 300 A IP20/UL Type 1 configuration requires ordering two items: PCSP300D2IP00 and PCSPWMKIT300A; adds 273 mm to IP00 length and 8.6 kg.

AccuSine PCS+ 380 - 480 V, 50/60 Hz							
Rated current	KVAR rating @ voltage	Catalog number	Enclosure			Frame	Weight kg
			Rating	Style	Cable entry		
60	39.5 @ 380 41.6 @ 400 43.1 @ 415 49.9 @ 480	PCSP060D5IP00	IP00 (chassis)	Wall mount	Bottom	1	88
		PCSP060D5N2	UL Type 2	Floor standing	Top or Bottom	2	277
		PCSP060D5IP31	IP31				291
		PCSP060D5N12	UL Type 12				
		PCSP060D5IP54	IP54				
120	79.0 @ 380 83.1 @ 400 86.3 @ 415 99.8 @ 480	PCSP120D5IP00	IP00 (chassis)	Wall mount	Bottom	3	113
		PCSP120D5N2	UL Type 2	Floor standing	Top or Bottom	4	279
		PCSP120D5IP31	IP31				293
		PCSP120D5N12	UL Type 12				
		PCSP120D5IP54	IP54				
200	131.6 @ 380 138.6 @ 400 143.8 @ 415 166.3 @ 480	PCSP200D5IP00	IP00 (chassis)	Wall mount	Bottom	5	171
		PCSP200D5N1	UL Type 1	Floor standing	Top or Bottom	11	363
		PCSP200D5N2	UL Type 2			6	384
		PCSP200D5IP31	IP31				402
		PCSP200D5N12	UL Type 12				
		PCSP200D5IP54	IP54				
300	197.5 @ 380 207.8 @ 400 215.6 @ 415 249.4 @ 480	PCSP300D5IP00	IP00 (chassis)			Wall mount	Bottom
		PCSP300D5N1	UL Type 1	Floor standing	Top or Bottom	11	402
		PCSP300D5N2	UL Type 2			8	422
		PCSP300D5IP31	IP31				436
		PCSP300D5N12	UL Type 12				
		PCSP300D5IP54	IP54				

Note:

60 A IP20/UL Type 1 configuration requires ordering two items: PCSP060D5IP00 and PCSPWMKIT60A; adds 232 mm to IP00 length and 8.7 kg.
 120 A IP20/UL Type 1 configuration requires ordering two items: PCSP120D5IP00 and PCSPWMKIT120A; adds 232 mm to IP00 length and 9.3 kg.
 200 A IP20/UL Type 1 configuration requires ordering two items: PCSP200D5IP00 and PCSPWMKIT300A; adds 273 mm to IP00 length and 8.6 kg.
 300 A IP20/UL Type 1 configuration requires ordering two items: PCSP300D5IP00 and PCSPWMKIT300A; adds 273 mm to IP00 length and 8.6 kg.

Active Harmonic Compensation Offer

Selection Table

AccuSine PCS+ 480 - 600 V, 50/60 Hz							
Rated current	KVAR rating @ voltage	Catalog number	Enclosure		Cable entry	Frame	Weight kg
			Rating	Style			
47	48.8 @ 600	PCSP047D6N2	UL Type 2	Floor standing	Top or Bottom	9	461
		PCSP047D6IP31	IP31				
		PCSP047D6N12	UL Type 12				
		PCSP047D6IP54	IP54				
94	97.7 @ 600	PCSP094D6N2	UL Type 2	Floor standing	Top or Bottom	9	498
		PCSP094D6IP31	IP31				
		PCSP094D6N12	UL Type 12				
		PCSP094D6IP54	IP54				
157	163.2 @ 600	PCSP157D6N2	UL Type 2	Floor standing	Top or Bottom	10	653
		PCSP157D6IP31	IP31				
		PCSP157D6N12	UL Type 12				
		PCSP157D6IP54	IP54				
235	244.2 @ 600	PCSP235D6N2	UL Type 2	Floor standing	Top or Bottom	10	757
		PCSP235D6IP31	IP31				
		PCSP235D6N12	UL Type 12				
		PCSP235D6IP54	IP54				

AccuSine PCS+ 600 - 690 V, 50/60 Hz							
Rated current	KVAR rating @ voltage	Catalog number	Enclosure		Cable entry	Frame	Weight kg
			Rating	Style			
40	47.8 @ 690	PCSP040D7N2	UL Type 2	Floor standing	Top or Bottom	9	483
		PCSP040D7IP31	IP31				
		PCSP040D7N12	UL Type 12				
		PCSP040D7IP54	IP54				
80	95.6 @ 690	PCSP080D7N2	UL Type 2	Floor standing	Top or Bottom	9	533
		PCSP080D7IP31	IP31				
		PCSP080D7N12	UL Type 12				
		PCSP080D7IP54	IP54				
133	159.0 @ 690	PCSP133D7N2	UL Type 2	Floor standing	Top or Bottom	10	709
		PCSP133D7IP31	IP31				
		PCSP133D7N12	UL Type 12				
		PCSP133D7IP54	IP54				
200	239.0 @ 690	PCSP200D7N2	UL Type 2	Floor standing	Top or Bottom	10	827
		PCSP200D7IP31	IP31				
		PCSP200D7N12	UL Type 12				
		PCSP200D7IP54	IP54				

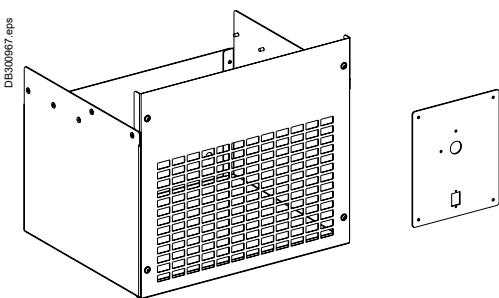

AccuSine+ Wall Mount IP20/UL Type 1 Conversion Kit

- Converts IP00 (UL Type Open) to IP20 (UL Type 1) wall mounted enclosed assemblies.
- Includes HMI mounting plate and cable entry enclosure for mounting on the bottom of the IP00 assemblies.

	Assembled dimensions - IP20				IP20 assembly Weight (kg)	Cable entry enclosure Weight (kg)
	Unit rating (A)	Height	Width	Depth		
Wall mount kit reference						
PCSPWMKIT60A	60	1530	421	349	97.3	8.7
PCSPWMKIT120A	120	1630	421	384	122.0	9.3
PCSPWMKIT300A	200	1642	575	435	180.0	8.6
PCSPWMKIT300A	300	1882	575	435	218.6	8.6

Electronic VAR Control Offer

AccuSine PFV+

Reactive current compensation solution for specific and high performance systems.

PF6502825_R.eps



PB115716.eps



Model 6 MCC (UL and CSA approved)

PD405100.eps



Okken / Blokset (IEC61439 certified)

AccuSine PFV+ Technical Specifications

Electrical System Characteristics

Standard RMS output current ratings	208 - 240 Vac: 60 A, 120 A, 200 A, 300 A 380 - 480 Vac: 60 A, 120 A, 200 A, 300 A 480 - 600 Vac: 47 A, 94 A, 157 A, 235 A 600 - 690 Vac: 40 A, 80 A, 133 A, 200 A
Nominal voltage	208 - 240 Vac, +10%/-10% 380 - 480 Vac; +10%/-15% 480 - 600 Vac; +10%/-15% 600 - 690 Vac; +10%/-15%
Nominal frequency	50/60 Hz, $\pm 3\%$ auto sensing
Number of phases	3-phase, with or without neutral

Technical Product Characteristics

Power electronics	IGBT; 3 level inverter
Control Topology	Digital 1/4 cycle response
Losses	At 480 Vac < 3 %; at 690 Vac < 5 %
Efficiency	to 480 Vac >97%; to 690 Vac >95%
Current transformers (CT)	Any ratio with 1 or 5 ampere secondary; Type 1 accuracy; 50/60 or 400 Hz rated (Instrument rated or better); Grounded; can be shared with other devices.
Quantity of CT	2 or 3 for 3-phase loads 3 required for 4-wire with neutral connected loads
CT VA loading	40 mVA
Control basis	Closed and open loop.
CT position	Grid sense (at mains) or load sense
Parallel operation	Upto 25 units per set of CT any size combination.
Parallel operation options	Master/Master (masters receive CT); Master/Slave; Multi-master/Multi-slave.
Parallel sequence options	Cascade: Lead/lag with unit rotation: one unit operates to full capacity before next unit turns on; timed rotation Load Share: All operating units function at the same output percentage
Parallel redundancy	Any unit with CT connections will automatically become master if the controlling master is taken offline. Automatic increase in output of all units to make up capacity of any offline unit.
Parallel HMI control	Any unit permits viewing and changing parameter settings of the complete system or any other unit in the parallel system.
Power factor correction	Optimized PF correction, leading (capacitive) or lagging (inductive) power factor (Cos ϕ) to target.
Mains current load balancing	Negative sequence current injected to balance fundamental current on the mains due to load imbalance (inherently corrects displacement PF (Cos ϕ)).
Voltage support (Volt-VAR mode)	Mains voltage support via VAR injection: Maintain defined set point voltage by injecting leading VARs to raise voltage and lagging VARs to lower voltage; includes speed of adjustment.
Control response time	25 μ s
Reactive correction time	$\leq 1/4$ cycle
Display	145 mm QVGA TFT 7-color touchscreen
Operators	Magelis HMI STU touch panel screen
Display parameters	100's: includes oscilloscope for viewing many selected parameters, phasor diagrams, load power, measured currents for Is, If, I neg seq, PF (Cos ϕ), injected currents for I reactive, I neg seq, etc.
Communications capability	Modbus RTU, Modbus TCP/IP
Discrete input/outputs	4 input and 4 output dry contacts; assignable
Noise level	< 70 db(A) typical
Color	RAL7035 Enclosure; RAL7022 Plinth (floor standing units)
Earthing (Grounding) systems	Suitable for most earthing (grounding) systems; IT switch on EMC filter for IT earthing (ground), high resistance earthing (ground) or corner earthed (grounded) systems.

AccuSine PFV+ Specifications

Environmental Conditions

Operating temperature	60 A, 120 A, and 200 A: IP00 (UL Type Open) and IP20 (UL Type N1 wall mount): 0...45 °C; All others: 0...40 °C; Derate 2% per °C upto 50 °C.
Relative humidity	0-95 %, noncondensing
Seismic rating	Complies with IBC and ASCE7 (Requires top anchorage for all floor standing models - rec. use NSYSFWFIX).
Operating altitude	1000 m, (derate 1% per 100 m above)
Ambient temperature safety	Automatic temperature roll back based upon any device OT. Absolute shutdown if air inlet temperature reaches 51 °C.
Preset output limits (rms)	Programmable set limit due to altitude or ambient temperature - becomes fixed output limit.
Storage (in original shipping container)	Temperature: -20...60 °C; Relative humidity: to 95 %, noncondensing; Clean, dry, and protected; No conductive particles permitted.
"Contaminant levels - operating (IEC 60721-3-3)"	Chemical Class 3C2; Mechanical Class 3S2; No conductive particles permitted.
"Contaminant levels - transport and storage (IEC 60721-3-3)"	Chemical Class 3C3; Mechanical Class 3S3; When stored in original shipping container; No conductive particles permitted.

Reference Standards

Design	CE EMC Certification IEC/EN 61439-1, EN 61000-6-4 Class A, EN 61000-6-2
Protection (enclosure)	IP31, IP54, UL Type 1, UL Type 2, and UL Type 12
Standards compliance/certification	cULus (UL508 , CSA 22.2 No. 14) CE Certified, ABS, other local standards

Installation

Wall mount	IP00 (UL Type Open) and IP20 (UL Type 1) configurations
Free standing	IP31, IP54, UL Type 2, and UL Type 12
Circuit protection	IP00 and IP20 - external means required. Supplied by others. Free standing enclosures - Incoming circuit breaker with mechanical door interlock.
AIC rating (applies to input circuit breaker ratings for free standing model enclosures)	to 240 Vac - 200 kA cULus; 150kA IEC to 415 Vac - 200 kA cULus; 125 kA IEC to 480 Vac - 200 kA cULus; 75 kA IEC to 600 Vac - 100 kA cULus; 20 kA IEC to 690 Vac - No cULus; 100 kA IEC
Cable entry	Wall mount: UL Type open, IP00, UL Type 1, and IP20 - bottom only. Free standing: top and bottom entry through gland plates.
PCBA protection	Conformal coating on all PCBAs.
Cooling configuration	Natural and forced ventilation; Separate air plenums for heat sink section and PCBA section; Heat sink plenum input from bottom with exhaust out top; All components in heat sink plenum rated IP54 or better => no filtering required; PCBA air supply must be clean and dry (filtering may be required); No conductive particles permitted.

Service provisions

HMI (Magelis STU)	Plain language output (no cryptic codes). Languages: English, French, Spanish, Portuguese, and Chinese. USB port for upload of new software and download of operational records.
Service port	USB port: commission, program, or diagnostics via a laptop computer when power is on or off; laptop provides power to control board when no unit power is present.
Commissioning	On-board step-by-step commissioning protocol via HMI; CT automatic sizing, phase rotation, and polarity; external transformer ratio and phase shift; heat test, and more.

Typical Applications



Oil and gas



Water



Cement



HVAC



Building



Wind turbines

- Oil and gas platforms
- Port cranes
- Steel
- Water/wastewater
- HVAC

- Automotive
- Process plants, pulp, and paper
- Wind and solar farms
- Lifts (ski or building)
- Marine vessels

Selection Table

AccuSine PFV+ 208 - 240 V, 50/60 Hz							
Rated current	KVAR rating @ voltage	Catalog number	Enclosure		Cable entry	Frame	Weight kg
			Rating	Style			
60	21.6 @ 208 24.9 @ 240	EVCP060D2IP00	IP00 (chassis)	Wall mount	Bottom	1	88
		EVCP060D2N2	UL Type 2	Floor standing	Top or Bottom	2	277
		EVCP060D2IP31	IP31				291
		EVCP060D2N12	UL Type 12				
		EVCP060D2IP54	IP54				
120	43.2 @ 208 49.9 @ 240	EVCP120D2IP00	IP00 (chassis)	Wall mount	Bottom	3	113
		EVCP120D2N2	UL Type 2	Floor standing	Top or Bottom	4	279
		EVCP120D2IP31	IP31				293
		EVCP120D2N12	UL Type 12				
		EVCP120D2IP54	IP54				
200	72.1 @ 208 83.1 @ 240	EVCP200D2IP00	IP00 (chassis)	Wall mount	Bottom	5	171
		EVCP200D2N1	UL Type 1	Floor standing	Top or Bottom	11	363
		EVCP200D2N2	UL Type 2			6	384
		EVCP200D2IP31	IP31				402
		EVCP200D2N12	UL Type 12				
300	108.1 @ 208 124.7 @ 240	EVCP300D2IP00	IP00 (chassis)	Wall mount	Bottom	7	210
		EVCP300D2N1	UL Type 1	Floor standing	Top or Bottom	11	402
		EVCP300D2N2	UL Type 2			8	422
		EVCP300D2IP31	IP31				436
		EVCP300D2N12	UL Type 12				
EVCP300D2IP54	IP54						

Note:

60 A IP20/UL Type 1 configuration requires ordering two items: EVCP060D2IP00 and PCSPWMKIT60A; adds 232 mm to length and 8.7 kg.
 120 A IP20/UL Type 1 configuration requires ordering two items: EVCP120D2IP00 and PCSPWMKIT120A; adds 232 mm to length and 9.3 kg.
 200 A IP20/UL Type 1 configuration requires ordering two items: EVCP200D2IP00 and PCSPWMKIT300A; adds 273 mm to length and 8.6 kg.
 300 A IP20/UL Type 1 configuration requires ordering two items: EVCP300D2IP00 and PCSPWMKIT300A; adds 273 mm to length and 8.6 kg.

AccuSine PFV+ 380 - 480 V, 50/60 Hz							
Rated current	KVAR rating @ voltage	Catalog number	Enclosure		Cable entry	Frame	Weight kg
			Rating	Style			
60	39.5 @ 380 41.6 @ 400 43.1 @ 415 49.9 @ 480	EVCP060D5IP00	IP00 (chassis)	Wall mount	Bottom	1	88
		EVCP060D5N2	UL Type 2	Floor standing	Top or Bottom	2	277
		EVCP060D5IP31	IP31				291
		EVCP060D5N12	UL Type 12				
		EVCP060D5IP54	IP54				
120	79.0 @ 380 83.1 @ 400 86.3 @ 415 99.8 @ 480	EVCP120D5IP00	IP00 (chassis)	Wall mount	Bottom	3	113
		EVCP120D5N2	UL Type 2	Floor standing	Top or Bottom	4	279
		EVCP120D5IP31	IP31				293
		EVCP120D5N12	UL Type 12				
		EVCP120D5IP54	IP54				
200	131.6 @ 380 138.6 @ 400 143.8 @ 415 166.3 @ 480	EVCP200D5IP00	IP00 (chassis)	Wall mount	Bottom	5	171
		EVCP200D5N1	UL Type 1	Floor standing	Top or Bottom	11	363
		EVCP200D5N2	UL Type 2			6	384
		EVCP200D5IP31	IP31				402
		EVCP200D5N12	UL Type 12				
EVCP200D5IP54	IP54						
300	197.5 @ 380 207.8 @ 400 215.6 @ 415 249.4 @ 480	EVCP300D5IP00	IP00 (chassis)	Wall mount	Bottom	7	210
		EVCP300D5N1	UL Type 1	Floor standing	Top or Bottom	11	402
		EVCP300D5N2	UL Type 2			8	422
		EVCP300D5IP31	IP31				436
		EVCP300D5N12	UL Type 12				
EVCP300D5IP54	IP54						

Note:

60 A IP20/UL Type 1 configuration requires ordering two items: EVCP060D5IP00 and PCSPWMKIT60A; adds 232 mm to length and 8.7 kg.
 120 A IP20/UL Type 1 configuration requires ordering two items: EVCP120D5IP00 and PCSPWMKIT120A; adds 232 mm to length and 9.3 kg.
 200 A IP20/UL Type 1 configuration requires ordering two items: EVCP200D5IP00 and PCSPWMKIT300A; adds 273 mm to length and 8.6 kg.
 300 A IP20/UL Type 1 configuration requires ordering two items: EVCP300D5IP00 and PCSPWMKIT300A; adds 273 mm to length and 8.6 kg.

Electronic VAR Control Offer

Selection Table

AccuSine PFV+ 480 - 600 V, 50/60 Hz							
Rated current	KVAR rating @ voltage	Catalog number	Enclosure			Frame	Weight kg
			Rating	Style	Cable entry		
47	48.8 @ 600	EVCP047D6N2	UL Type 2	Floor standing	Top or Bottom	9	461
		EVCP047D6IP31	IP31				
		EVCP047D6N12	UL Type 12				
		EVCP047D6IP54	IP54				
94	97.7 @ 600	EVCP094D6N2	UL Type 2	Floor standing	Top or Bottom	9	498
		EVCP094D6IP31	IP31				
		EVCP094D6N12	UL Type 12				
		EVCP094D6IP54	IP54				
157	163.2 @ 600	EVCP157D6N2	UL Type 2	Floor standing	Top or Bottom	10	653
		EVCP157D6IP31	IP31				
		EVCP157D6N12	UL Type 12				
		EVCP157D6IP54	IP54				
235	244.2 @ 600	EVCP235D6N2	UL Type 2	Floor standing	Top or Bottom	10	757
		EVCP235D6IP31	IP31				
		EVCP235D6N12	UL Type 12				
		EVCP235D6IP54	IP54				

AccuSine PFV+ 600 - 690 V, 50/60 Hz							
Rated current	KVAR rating @ voltage	Catalog number	Enclosure			Frame	Weight kg
			Rating	Style	Cable entry		
40	47.8 @ 690	EVCP040D7N2	UL Type 2	Floor standing	Top or Bottom	9	483
		EVCP040D7IP31	IP31				
		EVCP040D7N12	UL Type 12				
		EVCP040D7IP54	IP54				
80	95.6 @ 690	EVCP080D7N2	UL Type 2	Floor standing	Top or Bottom	9	533
		EVCP080D7IP31	IP31				
		EVCP080D7N12	UL Type 12				
		EVCP080D7IP54	IP54				
133	159.0 @ 690	EVCP133D7N2	UL Type 2	Floor standing	Top or Bottom	10	709
		EVCP133D7IP31	IP31				
		EVCP133D7N12	UL Type 12				
		EVCP133D7IP54	IP54				
200	239.0 @ 690	EVCP200D7N2	UL Type 2	Floor standing	Top or Bottom	10	827
		EVCP200D7IP31	IP31				
		EVCP200D7N12	UL Type 12				
		EVCP200D7IP54	IP54				

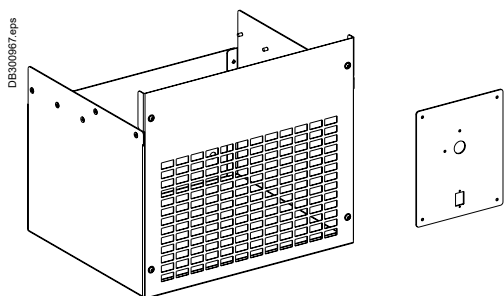

AccuSine+ Wall Mount IP20/UL Type 1 Conversion Kit

- Converts IP00 (UL Type Open) to IP20 (UL Type 1) wall-mounted enclosed assemblies.
- Includes HMI mounting plate and cable entry enclosure for mounting on the bottom of the IP00 assemblies.

	Assembled dimensions - IP20				IP20 assembly Weight (kg)	Cable entry enclosure Weight (kg)
	Unit rating (A)	Height	Width	Depth		
Wall mount kit reference						
PCSPWMKIT60A	60	1530	421	349	97.3	8.7
PCSPWMKIT120A	120	1630	421	384	122.0	9.3
PCSPWMKIT300A	200	1642	575	435	180.0	8.6
PCSPWMKIT300A	300	1882	575	435	218.6	8.6

Dimensions and Installation Guidelines

Unit Dimensions and Installation Guidelines for AccuSine PCSn

Frame size figure	Description	Exterior dimensions		
		Height mm	Width mm	Depth mm
12	AccuSine PCSn chassis IP00/UL Type OPEN	960	440	265
12	AccuSine PCSn wall mount IP20	960	440	265
13	AccuSine PCSn wall mount UL Type 1	1440	445	265
14	AccuSine PCSn rack mount	265	440	960

Note: UL Type OPEN dimensions exclude fuse kit

Frame size 12

Chassis mount IP00/UL Type OPEN

Wall mount IP20

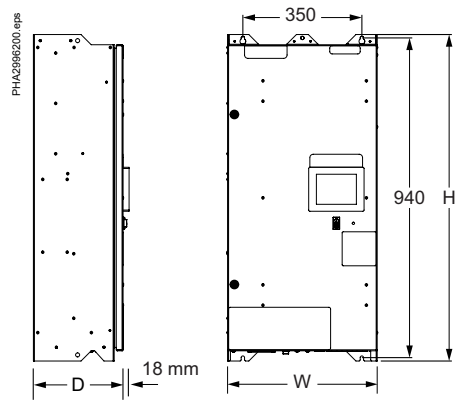
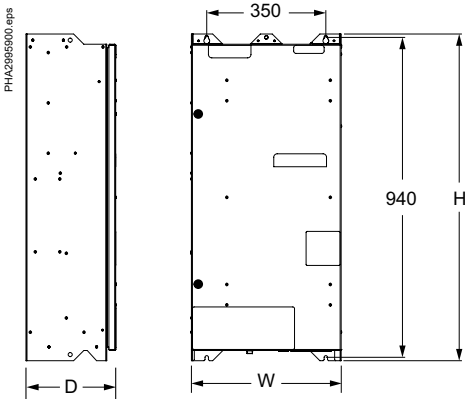

- HMI only on main unit – supplied loose in the box for mounting remotely.
- Expansion unit has the same dimensions as the main unit, except no HMI provided.

- HMI only on main unit.
- Expansion unit has the same dimensions as the main unit, except no HMI provided.

Note: Fuse kit shall be installed on line side to maintain $c_{UL_{US}}$ compliance.

Frame size 13

Wall mount UL Type 1

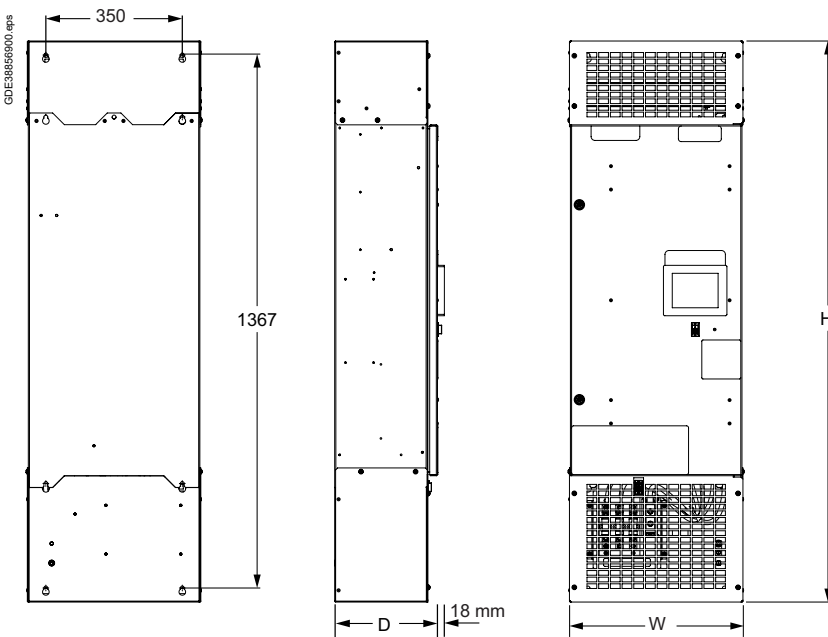

- HMI only on main unit.
- Expansion unit has the same dimensions as the main unit, except no HMI provided.

Note: All dimensions are indicative. Please refer to the dimensions in the Installation manual and engineering drawings for design purposes.

Dimensions and Installation Guidelines

Unit Dimensions and Installation Guidelines for AccuSine PCSn

Frame size figure	Description	Exterior dimensions		
		Height mm	Width mm	Depth mm
12	AccuSine PCSn chassis IP00/UL Type OPEN	960	440	265
12	AccuSine PCSn wall mount IP20	960	440	265
13	AccuSine PCSn wall mount UL Type 1	1440	445	265
14	AccuSine PCSn rack mount	265	440	960

Frame size 14

Note: UL Type OPEN dimensions exclude fuse kit

Rack mount

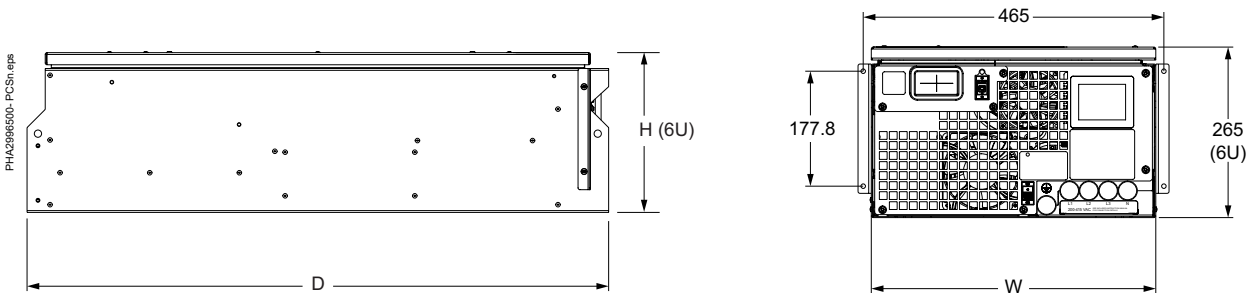

- HMI only on main unit.
- Expansion unit has the same dimensions as the main unit, except no HMI provided.

Accessories

Fuse kit

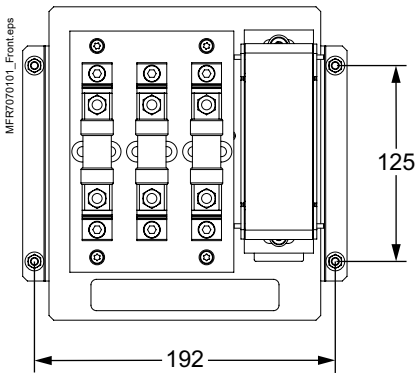

PCSNFUSKIT230 – for 20 & 30 A chassis models

PCSNFUSKIT560 – for 50 & 60 A chassis models

Note: Fuse kit required on line side of chassis IP00 model to maintain c_{ULUS} compliance.

Terminal kit

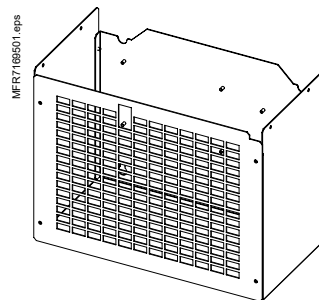
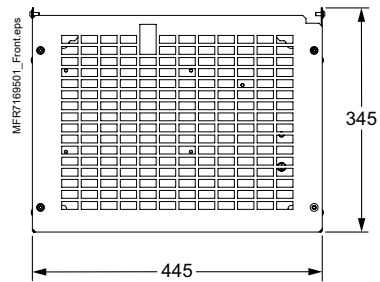

PCSNBTMKIT01 - optional cable termination box for chassis IP00 and wall mounted IP20 models

Note:

All dimensions are indicative. Please refer to the dimensions in the Installation manual and engineering drawings for design purposes.

Dimensions and Installation Guidelines

Unit Dimensions and Installation Guidelines for AccuSine PCS+ and AccuSine PFV+

Frame size figure	Exterior dimensions		
	Height mm	Width mm	Depth mm
1	1300	421	349
2	2100	800	500
3	1400	421	384
4	2100	800	500
5	1323	582	438
6	2100	900	600
7	1560	582	438
8	2100	900	600
9	2100	1300	500
10	2100	1400	600
11	2000	800	600

Frame size 1

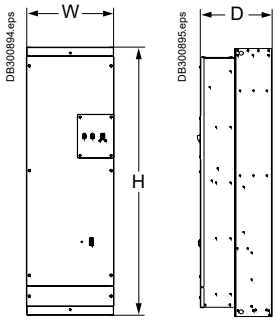

Frame size 2

IP31

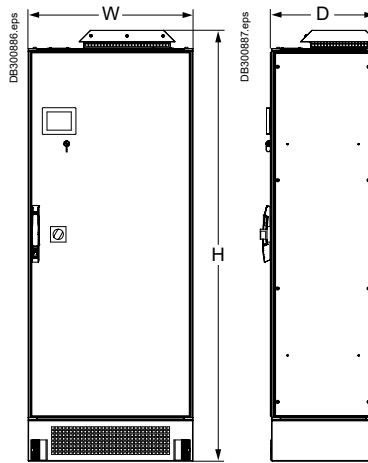

IP54

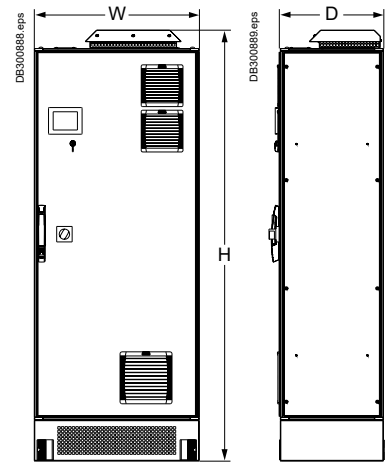

Frame size 3

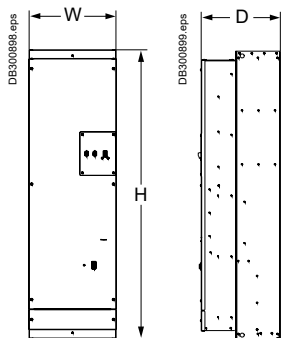

Frame size 4

IP31

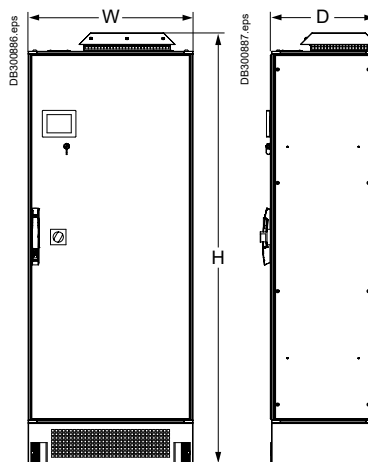

IP54

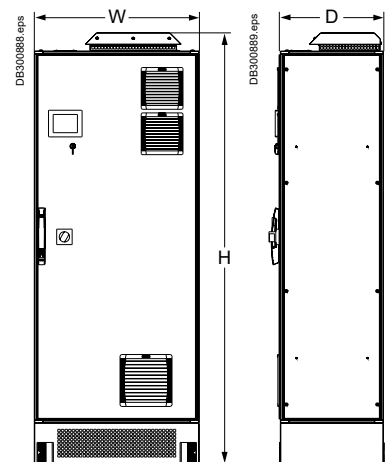

Note:

- Dimensions are subject to change without notice.
- Obtain current mechanical drawings at www.se.com.
- Please refer to installation manual and engineering drawings for design purposes.

Dimensions and Installation Guidelines

Unit Dimensions and Installation Guidelines for AccuSine PCS+ and AccuSine PFV+

Frame size 5

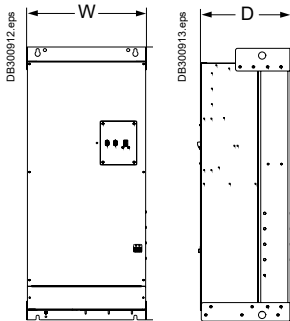

Frame size 6

IP31

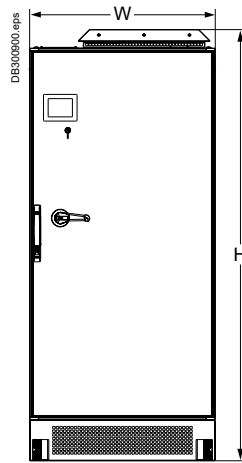

IP54

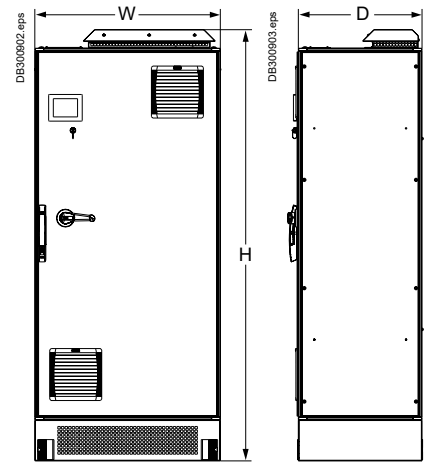

Frame size 7

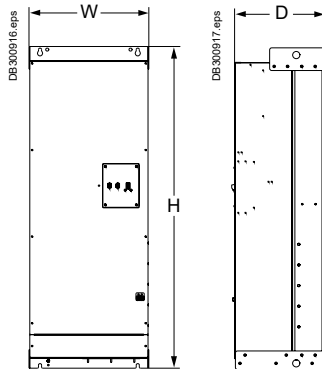

Frame size 8

IP31

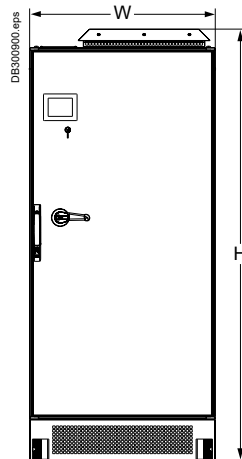

IP54

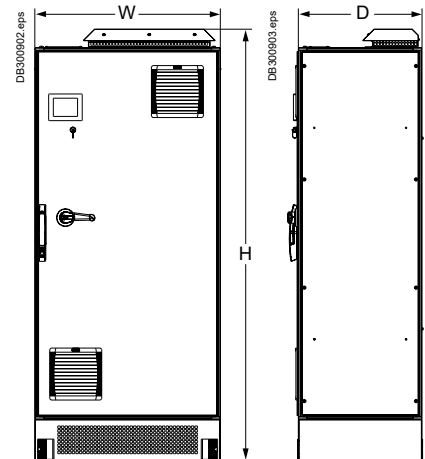

Frame size 9

IP31

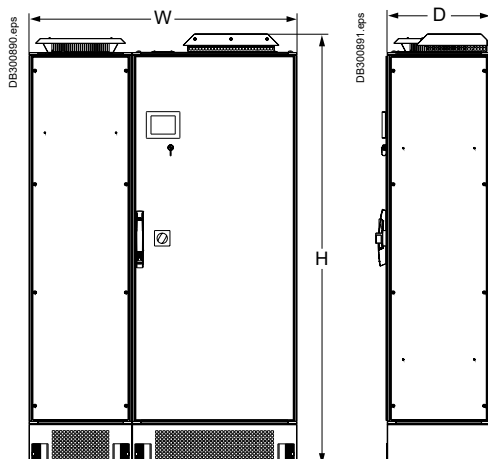

IP54

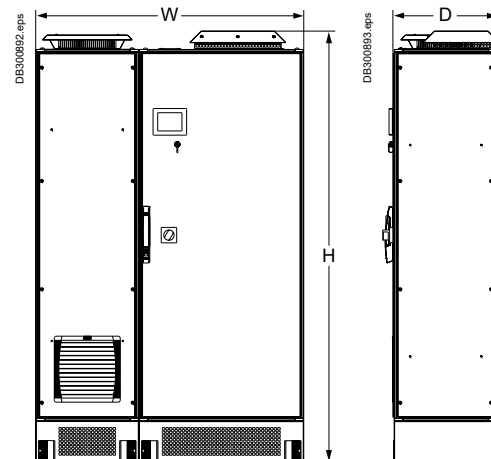

Note:

All dimensions are indicative. Please refer to the dimensions in the Installation manual and engineering drawings for design purposes.

Dimensions and Installation Guidelines

Unit Dimensions and Installation Guidelines for AccuSine PCS+ and AccuSine PFV+

Frame size 10

IP31 600 Vac

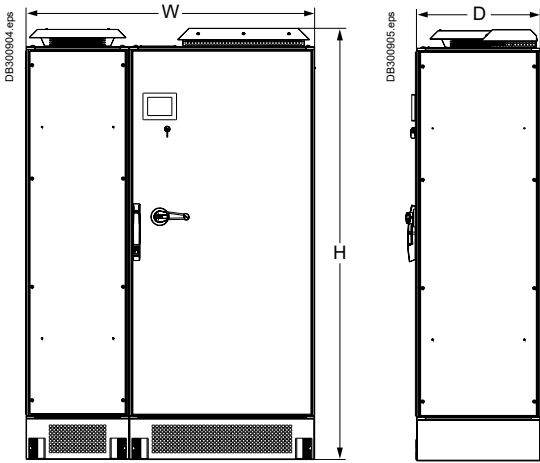

IP31 690 Vac

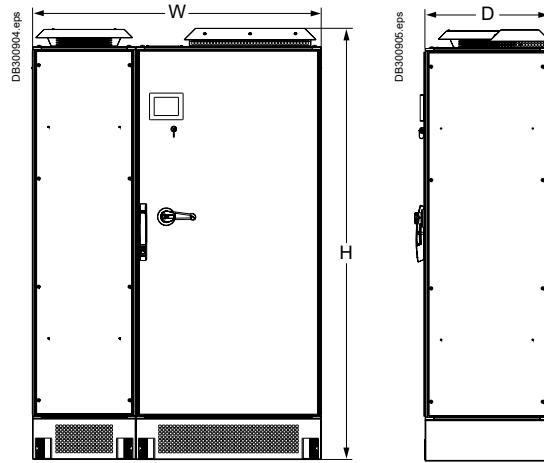

IP54 600 Vac

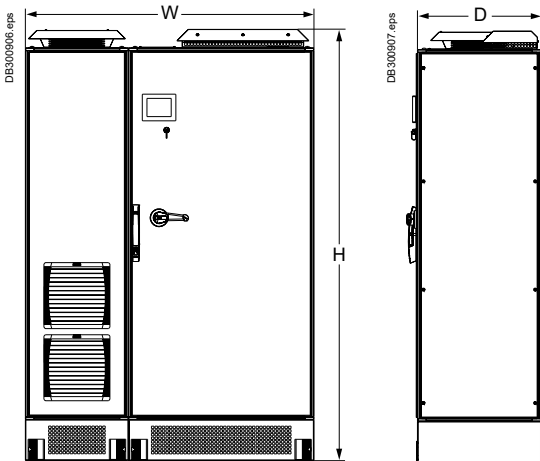

IP54 690 Vac

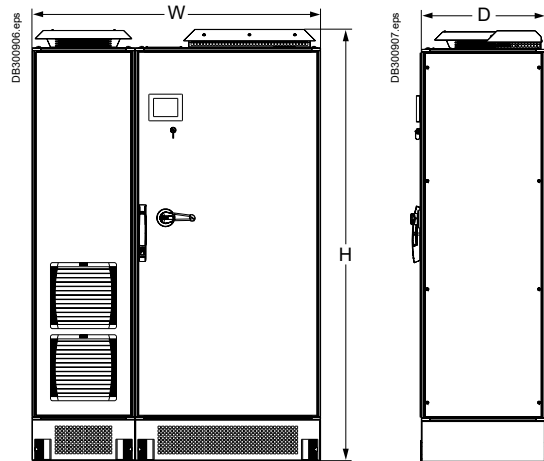

Frame size 11

UL Type 1 (IP20) 240-480 Vac

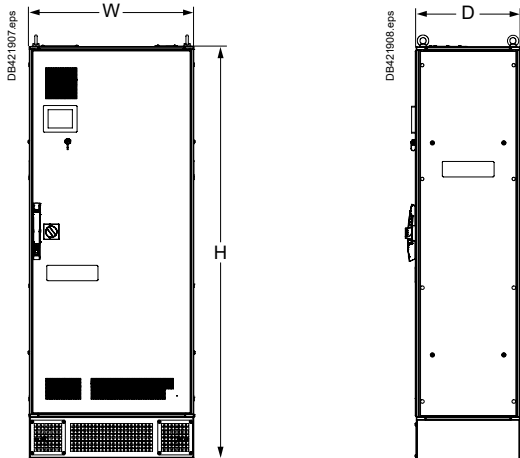

Note:

All dimensions are indicative. Please refer to the dimensions in the Installation manual and engineering drawings for design purposes.

Current Transformers and Accessories

Split Core Design



Specifications

Construction

Directional silicon steel is used for the flexible core. Secondary windings are of copper. Unit is encapsulated in silicone rubber which protects against moisture, dirt, oil, and corona.

Insulation level	0.72 KV. BIL 10 KV Full Wave	
Frequency	50 - 400 Hz	
Thermal factor	1.25 at 30 °C.. 1.0 at 55 °C	
Operating temp range	-45...+55 °C	
Altitude .	Up to 4000 meters	
Accuracy	200 thru 300	4 %
(primary rating)	400 thru 500	3 %
	600 thru 800	2 %
	1000 thru 6000	1 %
Secondary leads	3.65 m with spade connectors	
Color	Transformer (red) - Leads (yellow)	
Remains flexible from	-45...+200 °C	



Twisting motion opens to CT diameter of round CT and smaller distance of rectangular CT.

Round Split Core Design

Reference number by secondary current		Maximum load (A)	Inside diameter (ID) mm - A	Burden capacity (Ω)		Weight (kg)
5 A	1 A			5 A	1 A	
PCSPCTFCL50054	PCSPCTFCL50014	500	101.6	0.120	2.0	1.6
PCSPCTFCL100054	PCSPCTFCL100014	1000	101.6	0.200	10.0	1.6
PCSPCTFCL150054		1500	101.6	0.375	15.0	1.6
PCSPCTFCL160054		1600	101.6	0.375	15.0	1.6
PCSPCTFCL50056		500	152.4	0.120	2.0	1.9
	PCSPCTFCL100016	1000	152.4	0.200	10.0	1.9
PCSPCTFCL120056		1200	152.4	0.200	15.0	1.9
PCSPCTFCL150056	PCSPCTFCL150016	1500	152.4	0.375	15.0	1.9
PCSPCTFCL200056	PCSPCTFCL200016	2000	152.4	1.000	18.0	1.9
PCSPCTFCL250056		2500	152.4	1.400	20.0	1.9
PCSPCTFCL300056		3000	152.4	1.800	20.0	1.9
	PCSPCTFCL200018	2000	203.2	1.000	18.0	2.5
PCSPCTFCL250058		2500	203.2	1.400	20.0	2.5
PCSPCTFCL400058		4000	203.2	1.800	20.0	2.5
PCSPCTFCL500058		5000	203.2	1.800	20.0	2.5
PCSPCTFCL2500511		2500	279.4	1.400	20.0	3.4

Note: Open split-core with a twisting motion only.



Rectangular Split Core Design

Reference number by secondary current		Maximum load (A)	Inside diameter (ID) mm		Burden capacity (Ω)		Weight (kg)
5 A	1 A		A	B	5 A	1 A	
PCSPCTFCL5005R	PCSPCTFCL5001R	500	69.8	168.2	0.12	2.0	1.9
PCSPCTFCL10005R	PCSPCTFCL10001R	1000	69.8	168.2	0.2	10.0	1.9
PCSPCTFCL12005R	PCSPCTFCL12001R	1200	69.8	168.2	0.2	15.0	1.9
PCSPCTFCL15005R	PCSPCTFCL15001R	1500	69.8	168.2	0.375	15.0	1.9
PCSPCTFCL16005R	PCSPCTFCL16001R	1600	69.8	168.2	0.375	15.0	1.9
PCSPCTFCL20005R		2000	69.8	168.2	1	18.0	1.9
PCSPCTFCL30005R		3000	69.8	168.2	1.8	20.0	1.9
PCSPCTFCL25005R411	PCSPCTFCL25001R411	2500	101.6	279.4	1.4	20.0	2.8
PCSPCTFCL30005R411		3000	101.6	279.4	1.8	20.0	2.8
PCSPCTFCL40005R411		4000	101.6	279.4	1.8	20.0	2.8
PCSPCTFCL50005R411		5000	101.6	279.4	1.8	20.0	2.8

Dimensions

ID A	Dimensions in mm		
	B	C	D
101.6	31.75	38.1	165.1
152.4	31.75	38.1	215.9
203.2	31.75	38.1	266.7
279.4	31.75	38.1	342.9

ID A	B	Dimensions in mm		
		C	D	E
69.8	168.2	139.7	238	38.1
101.6	279.4	165.1	339.7	38.1

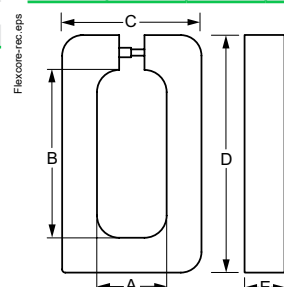
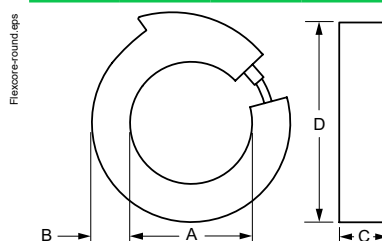

Current Transformers and Accessories

Round Solid Core design

Specifications

Frequency	50 - 400 Hz
Class	0.6 kV, 10 kV BIL Full Wave
Flexible leads	UL1015, 105 °C; CSA approved; 16 AWG (1.31 mm ²), 609.6 mm
Weight	Approximately 0.68 kg
Accuracy	1 %



Round Solid Core Design

Reference number by secondary current		Maximum load (A)	Burden capacity (Ω)	
5 A	1 A		5 A	1 A
	PCSPCT7RL2011	200	0.5	5.0
PCSPCT7RL3015	PCSPCT7RL3011	300	0.5	5.0
PCSPCT7RL4015	PCSPCT7RL4011	400	0.6	7.5
PCSPCT7RL5015	PCSPCT7RL5011	500	1.0	10.0
PCSPCT7RL6015	PCSPCT7RL6011	600	1.2	12.5
PCSPCT7RL7515	PCSPCT7RL7511	750	1.2	12.5
PCSPCT7RL8015	PCSPCT7RL8011	800	1.4	20.0
PCSPCT7RL1025	PCSPCT7RL1021	1000	1.4	25.0
PCSPCT7RL1225	PCSPCT7RL1221	1200	1.4	15.0
PCSPCT7RL1525	PCSPCT7RL1521	1500	1.6	20.0
PCSPCT7RL1625	PCSPCT7RL1621	1600	2.0	25.0



Dimensions (mm)

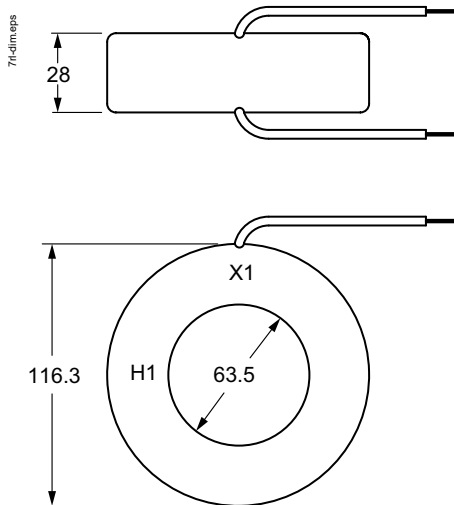

Current Transformers and Accessories

Auxiliary and Summing Transformers



Description

- The Reference 'PCSCT190X...' is an auxiliary transformer for use in the secondary of mains current transformers to change the ratio.
- The Reference 'PCSCT190XSUM...' is a summing transformer for use when three or five current transformers need to be totalized.

Specifications

Frequency	50 - 400 Hz
Thermal factor	1.33 at 30 °C, 1.0 at 55 °C
Secondary terminals	Brass Studs No. 8-32
Weight	Approximately 1.8 kg
Insulation class	0.6 kV, 10 kV BIL Full Wave

Note: Since these units are used in the secondary of another current transformer, they do not have a voltage rating. They are given a 2500 V - 60 Hz Hi Pot test. They are designed to be used on circuits not to exceed 600 V-to-ground or between windings.



Auxiliary Transformers

Reference number	Current ratio	Burden capacity (Ω)
PCSPCT190X1000	5:1	0.5
PCSPCT190X10005	1:5	0.5
PCSPCT190X5000	5:5	0.5

Summing Transformers ^[1]

Reference number	Current ratio	Burden capacity (Ω)
PCSPCT190XSUM3	5+5+5:5	0.3

[1] All current transformers to be totalized must have same ratio.

Dimensions (mm)

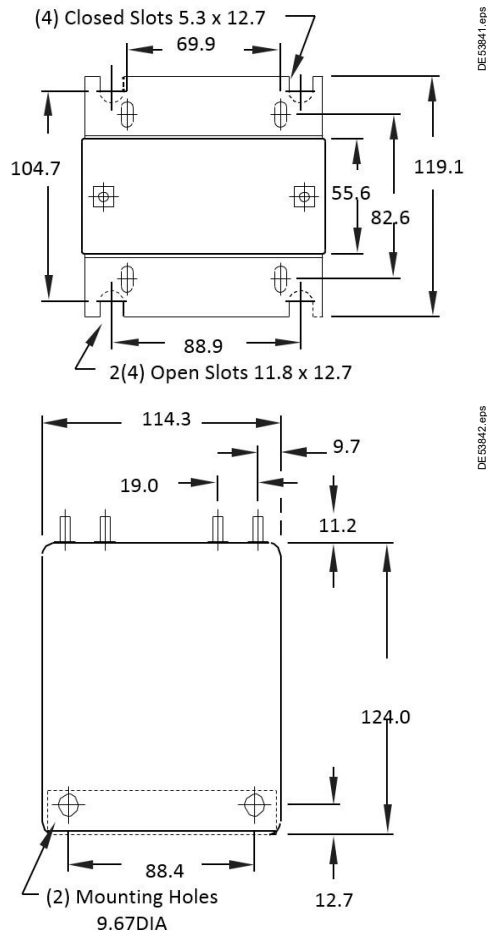

Shorting Terminal Switch and Parallel Connection Cables

Specifications

Rating	600 Vac, 30 A
Thermal rating	to 55 °C
Humidity	to 95%
Class 1E qualified per IEEE 323-1974	
This device is not CE Certified	



Shorting Terminal Switch	
Reference number	Description
PCSPNHA38255	CT shorting switch 6 terminals dpst

Dimensions

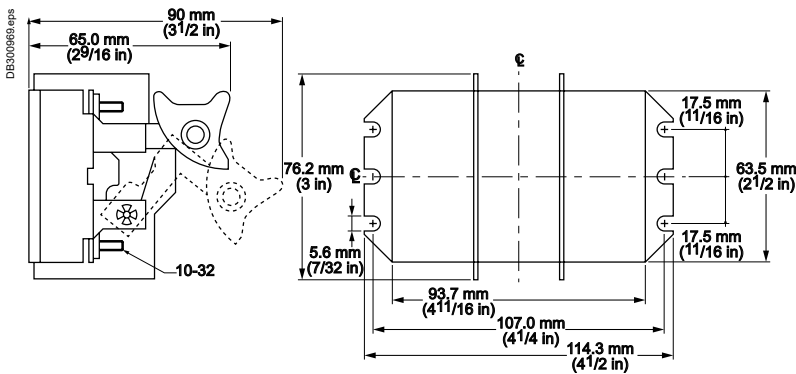

PCSPNHA3825

- Torque wire terminals to 0.565 nm
- Torque mounting screws to 2.26 nm

Parallel Connection Cables

- Parallel connection cables - shielded CAT5E type.
- Required to interconnect all units operating in parallel - requires N-1 cables, where N is the quantity of units operating in parallel.

Reference	Description	Length (m)
PCSPNHA38245	Paralleling cable CAT5E 4.5 m	4.5
PCSPNHA38247	Paralleling cable CAT5E 7.5 m	7.5
PCSPNHA38248	Paralleling cable CAT5E 9 m	9
PCSPNHA38249	Paralleling cable CAT5E 12 m	12
PCSPNHA38250	Paralleling cable CAT5E 15 m	15
PCSPNHA38252	Paralleling cable CAT5E 22 m	22
PCSPNHA38253	Paralleling cable CAT5E 30 m	30

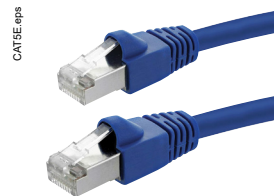

shielded CAT5e (or higher)

Human Machine Interface (HMI)

Human Machine Interface (HMI)

AccuSine+ products include a full color HMI with a Graphical User Interface. Direct control, programming, and monitoring are possible without a PC or the internet.

P8503017_09s



Touch Screen

Direct control of AccuSine+ units is possible by using the touch screen.

Display

A graphical display is used for different functions:

- accessing and setting up of operating parameters
 - measuring data
 - viewing operation status (warnings, fault messages)
- Menus are accessible for easy navigation.

Configuration Parameters

List of selectable parameters:

- 3- or 4-wire configuration
- harmonics or reactive energy compensation (separately or in combination)
- current transformer ratio
- power factor target
- number of units in parallel
- communication parameters

Measurements

A complete set of measurement data is accessible:

- line-to-line r.m.s. voltages
- total r.m.s load currents (on three phases)
- active filter output r.m.s currents (on three phases)
- harmonic r.m.s load and line currents
- voltage and current distortions (THDu and THDi)
- reactive r.m.s load current
- active filter reactive r.m.s output current
- heatsink temperature (in deg. C)

Alarms and Fault Display

Detailed alarms and fault messages are displayed for easy trouble shooting:

- supply voltage or frequency outside of normal operating range
- current limitation
- overtemperature
- controller fault
- communication fault

Find More About Power Quality Solutions

We deliver smart and cost-effective power quality solutions to improve our customers efficiency.

AccuSine

Active Power Correction for Harmonic Mitigation, Reactive Power Compensation and Mains Current Balancing

Bring efficiency and reliability to your operation



Find out more visit
www.se.com
and download
AMTED109015EN

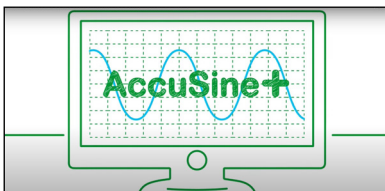

[Find out how to fix your power quality issues](#)



[Real-time performance and capability of AccuSine PCSn](#)

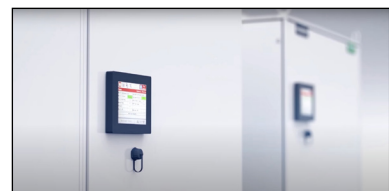

[Take control of your operation today with AccuSine PCS+](#)

VarSet Smart

Intelligent LV Capacitor Banks

Digitize your power factor correction

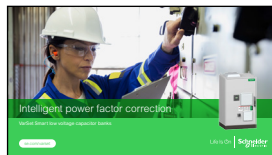

Find out more visit
www.se.com
and download
998-1164795_GMA_VarSet_eBro

Relevant documents

Relevant documents published by Schneider Electric

- Electrical Installation Guide
- Expert Guide n° 4: Harmonic
- Expert Guide n° 6: Power Factor Correction and Harmonic Filtering Guide
- Technical Guide 152: Harmonic disturbances in networks, and their treatment
- Technical Guide n° 202: The singularities of the third harmonic
- White paper: controlling the impact of Power Factor and Harmonics on Energy Efficiency
- Harmonic mitigation - Solution Handbook (SLTED109014EN)
- AccuSine+ Installation and User Manuals

Relevant standards

- IEC 62477-1 - Safety requirements for power electronic converter systems and equipment
- IEEE 519 - Recommended practice and requirements for Harmonic Control in Electric Power Systems
- IEC 61642 - Application of filters and shunt capacitors for industrial a.c. networks affected by harmonics

Find out more about Rack Systems and Cooling Solutions

The world's most versatile rack enclosure for demanding IT environments

Rack Solutions

Enclosure and rack systems

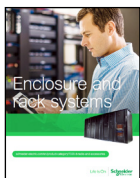

Find out more at www.se.com and download 998-4936_GMA-US_B

Cooling Solutions

Cooling Solutions for IT Equipment



Find out more at www.se.com and download 998-1158592_GMA-US

Effective cooling and cable management

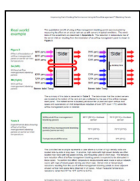

Improving Rack Cooling Performance Using Airflow Management™ Blanking Panels
Download
White Paper 44

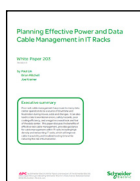

Planning Effective Power and Data Cable Management in IT Racks
Download
White Paper 203



Green Premium™

An industry leading portfolio of offers delivering sustainable value



More than 75% of our product sales offer superior transparency on the material content, regulatory information and environmental impact of our products:

- RoHS compliance
- REACH substance information
- Industry leading # of PEP's*
- Circularity instructions



Discover what we mean by green
[Check your products!](#)

The Green Premium program stands for our commitment to deliver customer valued sustainable performance. It has been upgraded with recognized environmental claims and extended to cover all offers including Products, Services and Solutions.

CO₂ and P&L impact through... Resource Performance

Green Premium brings improved resource efficiency throughout an asset's lifecycle. This includes efficient use of energy and natural resources, along with the minimization of CO₂ emissions.

Cost of ownership optimization through... Circular Performance

We're helping our customers optimize the total cost of ownership of their assets. To do this, we provide IoT-enabled solutions, as well as upgrade, repair, retrofit, and remanufacture services.

Peace of mind through... Well-being Performance

Green Premium products are RoHS and REACH compliant. We're going beyond regulatory compliance with step-by-step substitution of certain materials and substances from our products.

Improved sales through... Differentiation

Green Premium delivers strong value propositions through third-party labels and services. By collaborating with third-party organizations we can support our customers in meeting their sustainability goals such as green building certifications.

*PEP: Product Environmental Profile (i.e. Environmental Product Declaration)

Life Is On

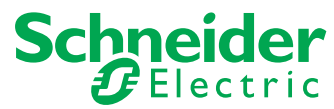

se.com/accusine

Schneider Electric Industries SAS
35, rue Joseph Monier - CS 30323
F92506 Rueil-Malmaison Cedex

03-2021
AMTED109015EN

This document has been
printed on recycled paper 