

Rack Air Containment Front Assembly for ACRC301S/301H (ACCS1009) - Installation

Safety

⚠ ⚠ DANGER

HAZARD OF ELECTRIC SHOCK, EXPLOSION, OR ARC FLASH

Turn off all electrical power before working on or near this equipment.

Failure to follow these instructions will result in death or serious injury.

na4393a

Inventory

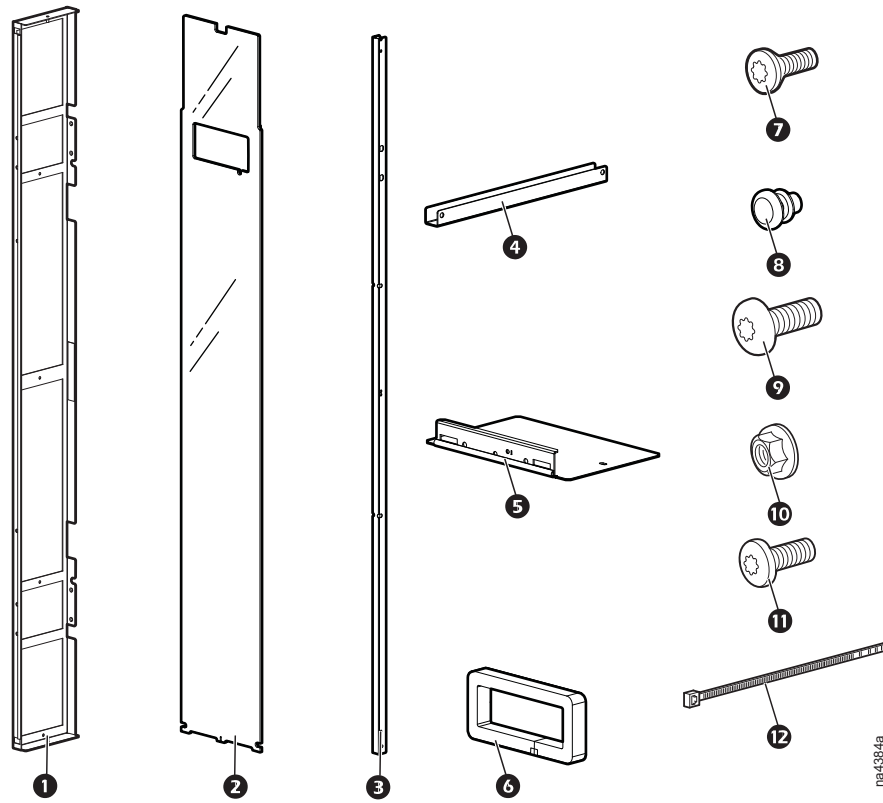

Item	Description	Quantity	Item	Description	Quantity
1	Side plenums	2	7	M6 x 12-mm flathead screw	8
2	Front insert	1	8	6-mm snap rivet	8
3	Side retainer inserts	2	9	M6 x 12-mm panhead screw (on unit)	1
4	Bottom retainer insert	1	10	M6 flanged hex nut	4
5	Top/bottom plenums	2	11	Display mounting hardware (included with display)	3
6	Display air block	1	12	Wire tie	3

Tools

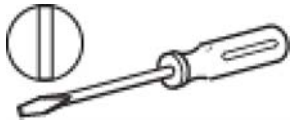

Flat head screwdriver



TORX screw driver

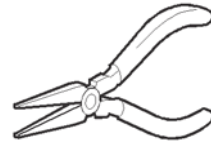

Needle-nose pliers

Installation

①

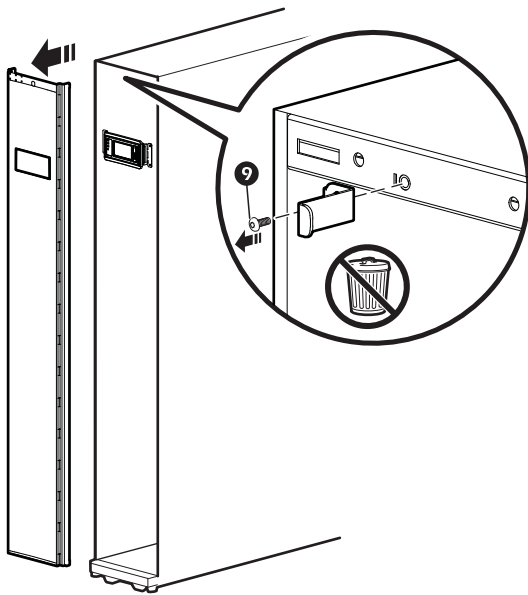

②

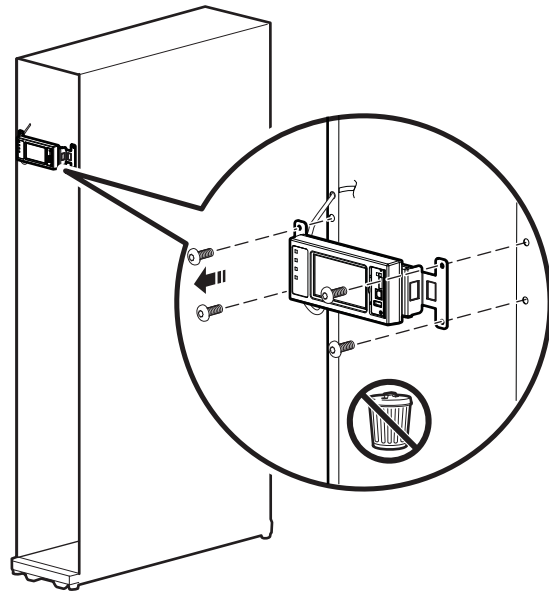

③

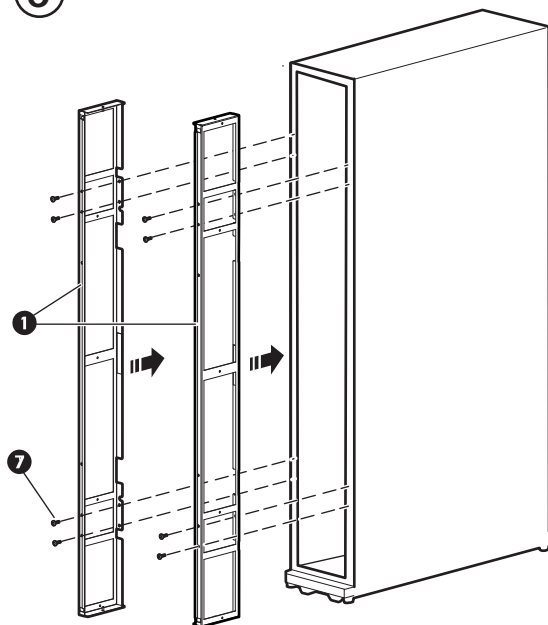

④

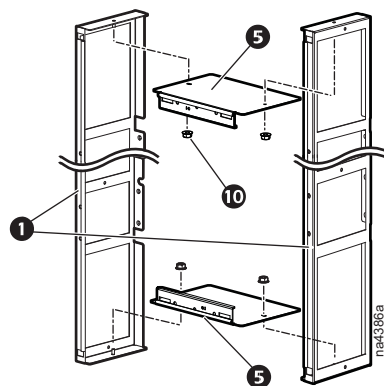

5

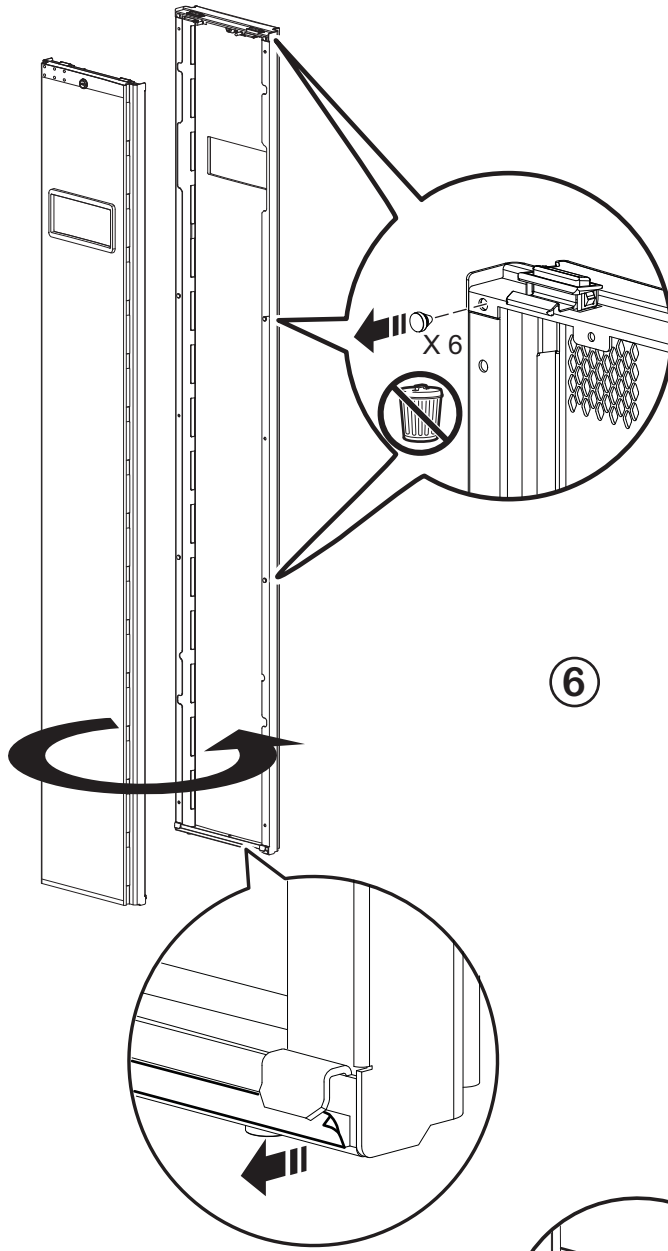

6

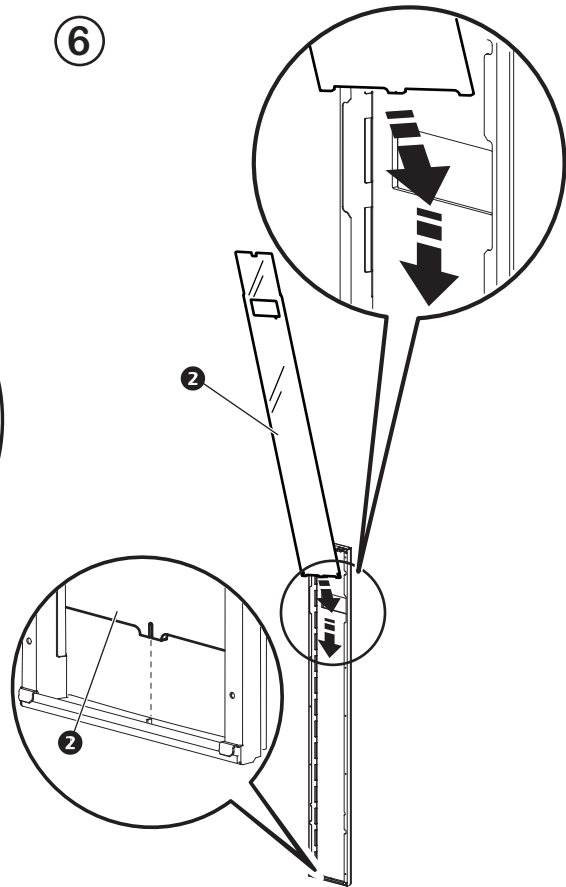

net4387a

7

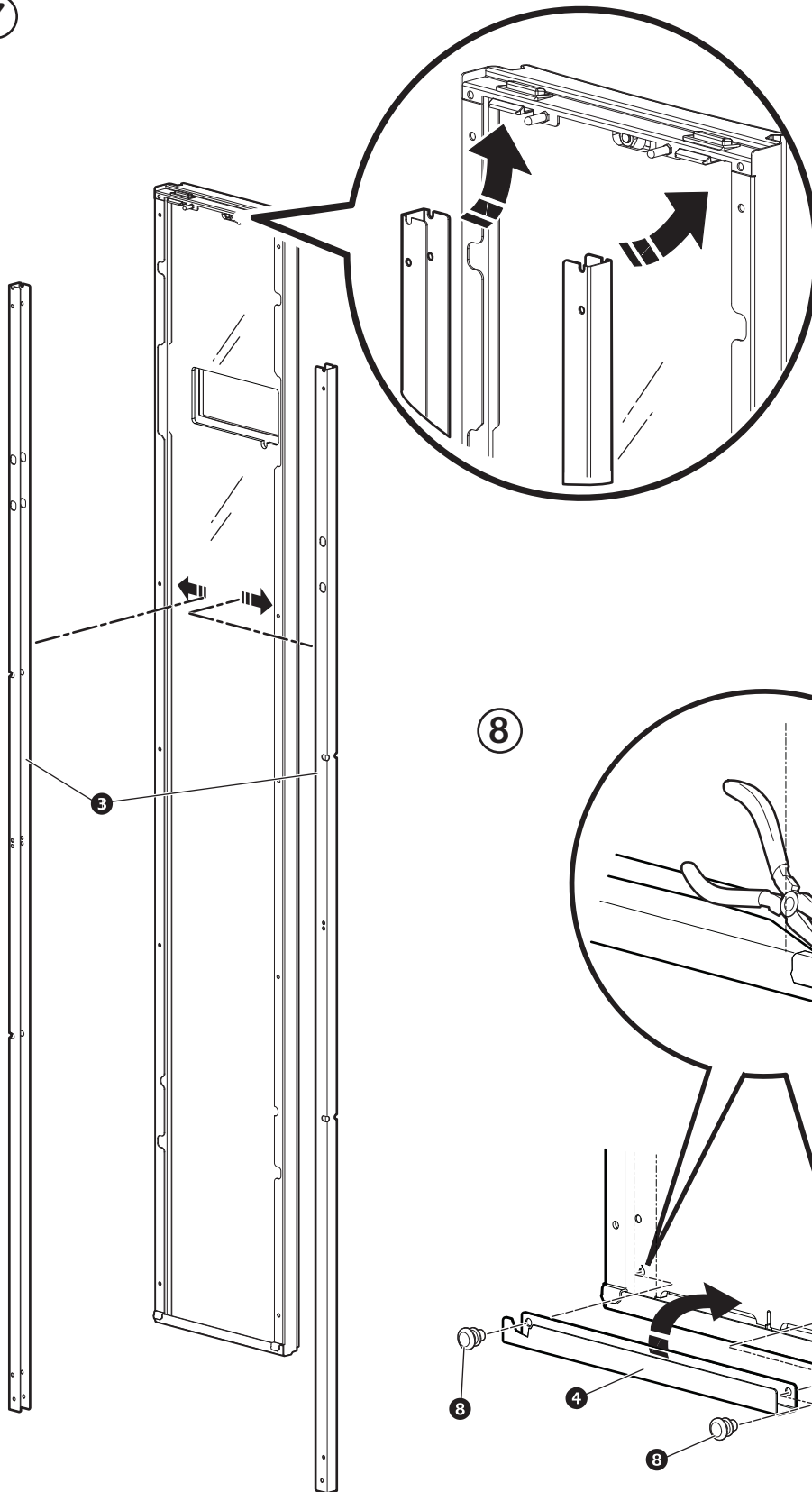

8

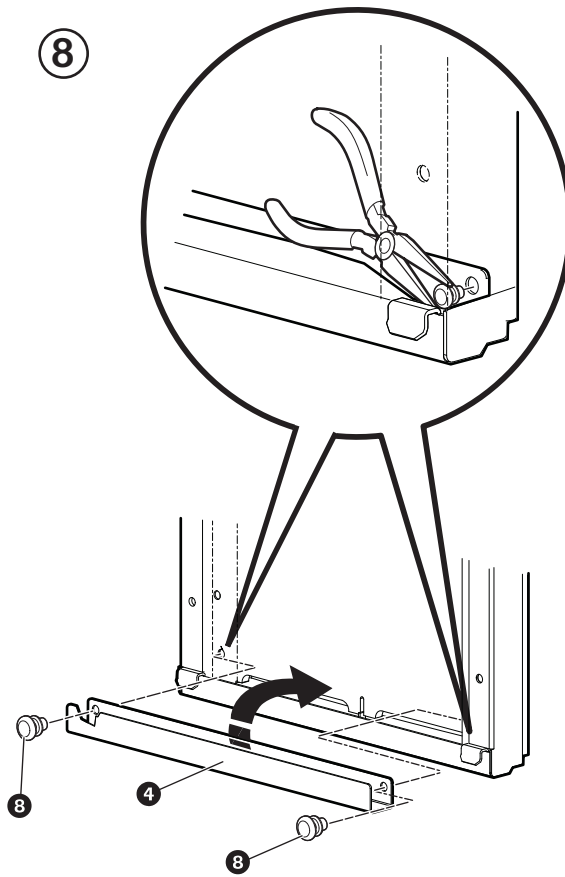

nak4358a

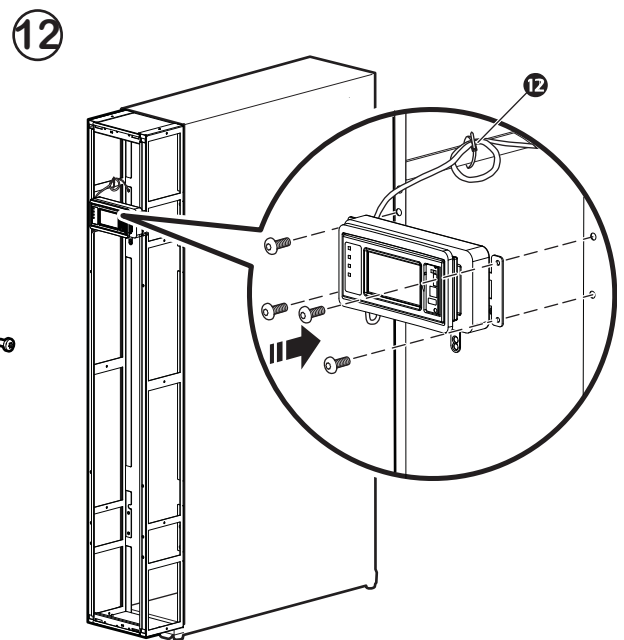
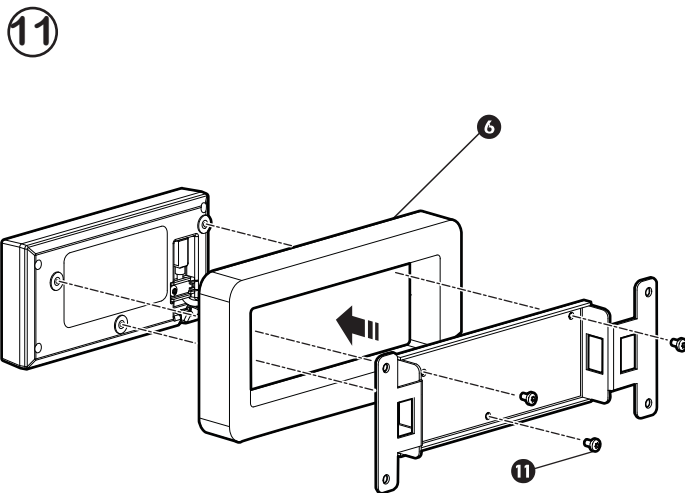
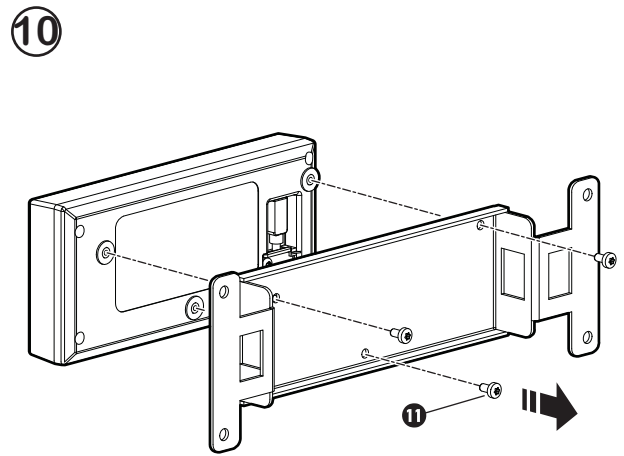
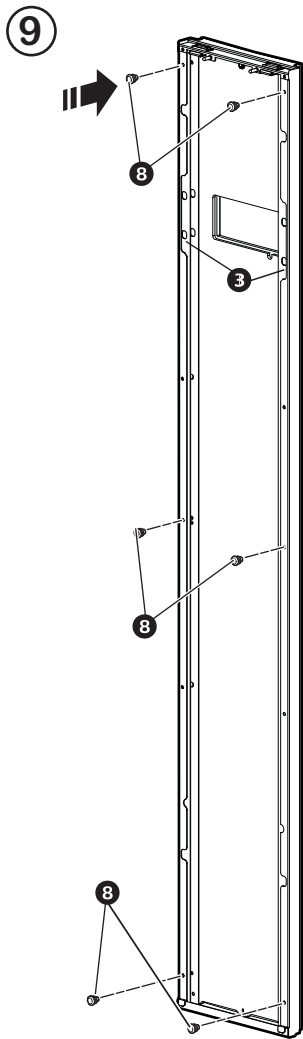

13

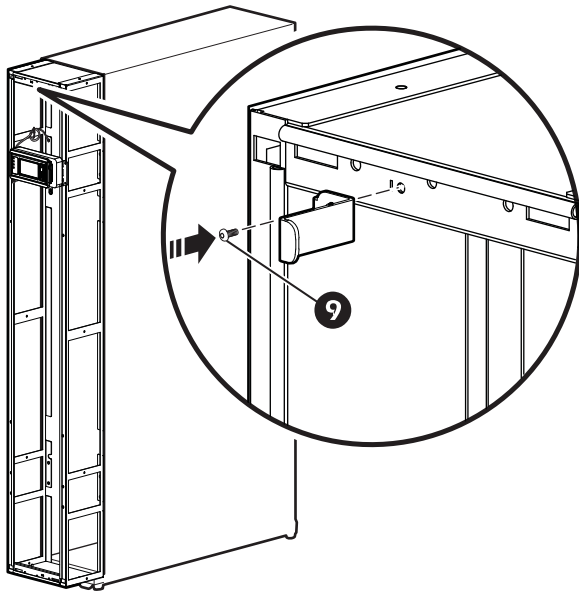

14

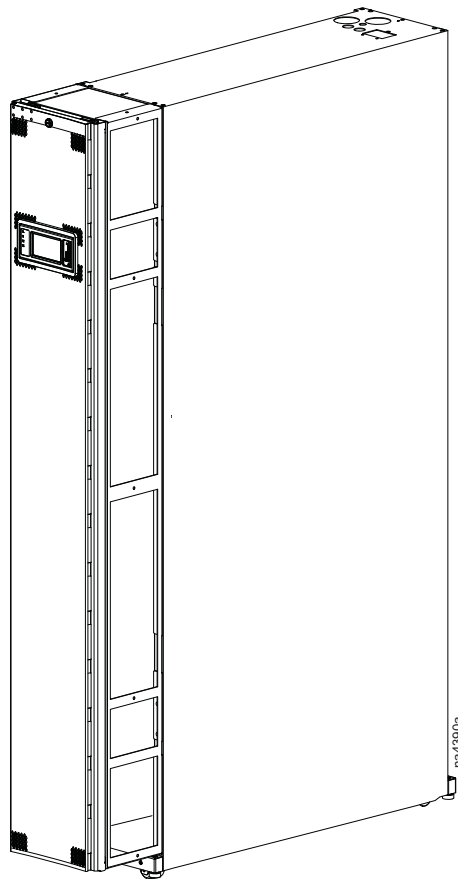
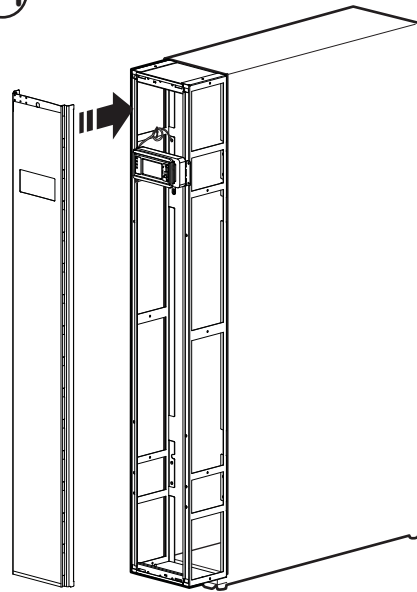

Customer support and warranty information is available at the APC Web site, www.apc.com.

© Schneider Electric, APC and the APC logo are owned by Schneider Electric Industries S.A.S., or its affiliated companies. All other trademarks are property of their respective owners.

990-5196
1/2014