

Galaxy VS

Maintenance Bypass Cabinet with Input/Output Transformer

Installation

GVSBPIT25, GVSBPIT50, GVSBPIT75, GVSBPOT50, GVSBPOT100, GVSBPOT150

1/2020



Legal Information

The Schneider Electric brand and any trademarks of Schneider Electric SE and its subsidiaries referred to in this guide are the property of Schneider Electric SE or its subsidiaries. All other brands may be trademarks of their respective owners.

This guide and its content are protected under applicable copyright laws and furnished for informational use only. No part of this guide may be reproduced or transmitted in any form or by any means (electronic, mechanical, photocopying, recording, or otherwise), for any purpose, without the prior written permission of Schneider Electric.

Schneider Electric does not grant any right or license for commercial use of the guide or its content, except for a non-exclusive and personal license to consult it on an "as is" basis. Schneider Electric products and equipment should be installed, operated, serviced, and maintained only by qualified personnel.

As standards, specifications, and designs change from time to time, information contained in this guide may be subject to change without notice.

To the extent permitted by applicable law, no responsibility or liability is assumed by Schneider Electric and its subsidiaries for any errors or omissions in the informational content of this material or consequences arising out of or resulting from the use of the information contained herein.



Go to
https://www.productinfo.schneider-electric.com/portals/ui/galaxyvs_ui/
or scan the QR code above for digital experience and translated manuals.

Table of Contents

Important Safety Instructions — SAVE THESE	
INSTRUCTIONS	5
FCC Statement	6
Safety Precautions	6
Additional Safety Precautions After Installation.....	8
Electrical Safety	8
Battery Safety	9
Specifications	10
Specifications for Maintenance Bypass Cabinet with Input Transformer (GVSBPIT25, GVSBPIT50, GVSBPIT75)	10
Trip Settings for Maintenance Bypass Cabinet with Input Transformer.....	10
Recommended Upstream Protection for Maintenance Bypass Cabinet with Input Transformer	11
Recommended Cable Sizes for Maintenance Bypass Cabinet with Input Transformer	12
Specifications for Maintenance Bypass Cabinet with Output Transformer (GVSBPOT50, GVSBPOT100, GVSBPOT150)	13
Trip Settings for Maintenance Bypass Cabinet with Output Transformer.....	13
Recommended Upstream Protection for Maintenance Bypass Cabinet with Output Transformer.....	14
Recommended Cable Sizes for Maintenance Bypass Cabinet with Output Transformer.....	14
Recommended Bolt and Lug Sizes	16
Torque Specifications.....	17
Maintenance Bypass Cabinet with Transformer Weights and Dimensions.....	17
Clearance	18
Environment.....	18
System Overview	19
Installation Procedure	20
Receiving	21
Unpack the Maintenance Bypass Cabinet	22
Prepare the Maintenance Bypass Cabinet for Cables	25
Install the Seismic Anchoring (Option)	27
Interconnect the UPS and the Maintenance Bypass Cabinet	29
Connect the Power Cables in a Maintenance Bypass Cabinet with Input Transformer	33
Connect the Power Cables in a Maintenance Bypass Cabinet with Output Transformer	34
Connect the Signal Cables	35
Final Installation	37

Important Safety Instructions — SAVE THESE INSTRUCTIONS

Read these instructions carefully and look at the equipment to become familiar with it before trying to install, operate, service or maintain it. The following safety messages may appear throughout this manual or on the equipment to warn of potential hazards or to call attention to information that clarifies or simplifies a procedure.



The addition of this symbol to a “Danger” or “Warning” safety message indicates that an electrical hazard exists which will result in personal injury if the instructions are not followed.



This is the safety alert symbol. It is used to alert you to potential personal injury hazards. Obey all safety messages with this symbol to avoid possible injury or death.

DANGER

DANGER indicates a hazardous situation which, if not avoided, **will result in death or serious injury.**

Failure to follow these instructions will result in death or serious injury.

WARNING

WARNING indicates a hazardous situation which, if not avoided, **could result in death or serious injury.**

Failure to follow these instructions can result in death, serious injury, or equipment damage.

CAUTION

CAUTION indicates a hazardous situation which, if not avoided, **could result in minor or moderate injury.**

Failure to follow these instructions can result in injury or equipment damage.

NOTICE

NOTICE is used to address practices not related to physical injury. The safety alert symbol shall not be used with this type of safety message.

Failure to follow these instructions can result in equipment damage.

Please Note

Electrical equipment should only be installed, operated, serviced, and maintained by qualified personnel. No responsibility is assumed by Schneider Electric for any consequences arising out of the use of this material.

A qualified person is one who has skills and knowledge related to the construction, installation, and operation of electrical equipment and has received safety training to recognize and avoid the hazards involved.

FCC Statement

NOTE: This equipment has been tested and found to comply with the limits for a Class A digital device, pursuant to Part 15 of the FCC Rules. These limits are designed to provide reasonable protection against harmful interference when the equipment is operated in a commercial environment. This equipment generates, uses, and can radiate radio frequency energy and, if not installed and used in accordance with the instruction manual, may cause harmful interference to radio communications. Operation of this equipment in a residential area is likely to cause harmful interference in which case the user will be required to correct the interference at his own expense.

Any changes or modifications not expressly approved by the party responsible for compliance could void the user's authority to operate the equipment.

Safety Precautions

DANGER

HAZARD OF ELECTRIC SHOCK, EXPLOSION, OR ARC FLASH

Read all instructions in the installation manual before installing or working on this product.

Failure to follow these instructions will result in death or serious injury.

DANGER

HAZARD OF ELECTRIC SHOCK, EXPLOSION, OR ARC FLASH

Do not install the product until all construction work has been completed and the installation room has been cleaned.

Failure to follow these instructions will result in death or serious injury.

DANGER

HAZARD OF ELECTRIC SHOCK, EXPLOSION, OR ARC FLASH

The product must be installed according to the specifications and requirements as defined by Schneider Electric. It concerns in particular the external and internal protections (upstream breakers, battery breakers, cabling, etc.) and environmental requirements. No responsibility is assumed by Schneider Electric if these requirements are not respected.

Failure to follow these instructions will result in death or serious injury.

DANGER

HAZARD OF ELECTRIC SHOCK, EXPLOSION, OR ARC FLASH

The UPS system must be installed according to local and national regulations. Install the UPS according to:

- IEC 60364 (including 60364-4-41- protection against electric shock, 60364-4-42 - protection against thermal effect, and 60364-4-43 - protection against overcurrent), **or**
- NEC NFPA 70, **or**
- Canadian Electrical Code (C22.1, Part 1)

depending on which one of the standards apply in your local area.

Failure to follow these instructions will result in death or serious injury.

⚠ ⚠ DANGER

HAZARD OF ELECTRIC SHOCK, EXPLOSION, OR ARC FLASH

- Install the product in a temperature controlled indoor environment free of conductive contaminants and humidity.
- Install the product on a non-flammable, level and solid surface (e.g. concrete) that can support the weight of the system.

Failure to follow these instructions will result in death or serious injury.

⚠ ⚠ DANGER

HAZARD OF ELECTRIC SHOCK, EXPLOSION, OR ARC FLASH

The product is not designed for and must therefore not be installed in the following unusual operating environments:

- Damaging fumes
- Explosive mixtures of dust or gases, corrosive gases, or conductive or radiant heat from other sources
- Moisture, abrasive dust, steam or in an excessively damp environment
- Fungus, insects, vermin
- Salt-laden air or contaminated cooling refrigerant
- Pollution degree higher than 2 according to IEC 60664-1
- Exposure to abnormal vibrations, shocks, and tilting
- Exposure to direct sunlight, heat sources, or strong electromagnetic fields

Failure to follow these instructions will result in death or serious injury.

⚠ ⚠ DANGER

HAZARD OF ELECTRIC SHOCK, EXPLOSION, OR ARC FLASH

Do not drill or cut holes for cables or conduits with the gland plates installed and do not drill or cut holes in close proximity to the UPS.

Failure to follow these instructions will result in death or serious injury.

⚠ ⚠ WARNING

HAZARD OF ARC FLASH

Do not make mechanical changes to the product (including removal of cabinet parts or drilling/cutting of holes) that are not described in the installation manual.

Failure to follow these instructions can result in death, serious injury, or equipment damage.

NOTICE

RISK OF OVERHEATING

Respect the space requirements around the product and do not cover the ventilation openings when the product is in operation.

Failure to follow these instructions can result in equipment damage.

Additional Safety Precautions After Installation

DANGER

HAZARD OF ELECTRIC SHOCK, EXPLOSION, OR ARC FLASH

Do not install the UPS system until all construction work has been completed and the installation room has been cleaned. If additional construction work is needed in the installation room after this product has been installed, turn off the product and cover the product with the protective packaging bag the product was delivered in.

Failure to follow these instructions will result in death or serious injury.

Electrical Safety

This manual contains important safety instructions that should be followed during the installation and maintenance of the product.

DANGER

HAZARD OF ELECTRIC SHOCK, EXPLOSION, OR ARC FLASH

- Electrical equipment must be installed, operated, serviced, and maintained only by qualified personnel.
- Apply appropriate personal protective equipment (PPE) and follow safe electrical work practices.
- Disconnection devices for AC and DC must be provided by others, be readily accessible, and the function of the disconnect device marked for its function.
- Turn off all power supplying the product before working on or inside the equipment.
- Before working on the product, check for hazardous voltage between all terminals including the protective earth.
- The product contains an internal energy source. Hazardous voltage can be present even when disconnected from the mains supply. Before installing or servicing the product, ensure that the product is OFF and that utility/mains and batteries are disconnected. Wait five minutes before opening the product to allow the capacitors to discharge.
- The product must be properly earthed/grounded and due to a high leakage current, the earthing/grounding conductor must be connected first.

Failure to follow these instructions will result in death or serious injury.

When the input is connected through external isolators that, when opened, isolate the neutral or when the automatic backfeed isolation is provided external to the equipment or is connected to an IT power distribution system, a label must be fitted at the input terminals, and on all primary power isolators installed remotely from the installation area and on external access points between such isolators and the product, by the user, displaying the following text (or equivalent in a language which is acceptable in the country in which the product is installed):

DANGER

HAZARD OF ELECTRIC SHOCK, EXPLOSION, OR ARC FLASH

Risk of voltage backfeed. Before working on this circuit: Isolate the product and check for hazardous voltage between all terminals including the protective earth.

Failure to follow these instructions will result in death or serious injury.

Battery Safety

⚠️⚠️ DANGER

HAZARD OF ELECTRIC SHOCK, EXPLOSION, OR ARC FLASH

- Battery circuit breakers must be installed according to the specifications and requirements as defined by Schneider Electric.
- Servicing of batteries must only be performed or supervised by qualified personnel knowledgeable of batteries and the required precautions. Keep unqualified personnel away from batteries.
- Disconnect charging source prior to connecting or disconnecting battery terminals.
- Do not dispose of batteries in a fire as they can explode.
- Do not open, alter, or mutilate batteries. Released electrolyte is harmful to the skin and eyes. It may be toxic.

Failure to follow these instructions will result in death or serious injury.

⚠️⚠️ DANGER

HAZARD OF ELECTRIC SHOCK, EXPLOSION, OR ARC FLASH

Batteries can present a risk of electric shock and high short-circuit current. The following precautions must be observed when working on batteries

- Remove watches, rings, or other metal objects.
- Use tools with insulated handles.
- Wear protective glasses, gloves and boots.
- Do not lay tools or metal parts on top of batteries.
- Disconnect the charging source prior to connecting or disconnecting battery terminals.
- Determine if the battery is inadvertently grounded. If inadvertently grounded, remove source from ground. Contact with any part of a grounded battery can result in electric shock. The likelihood of such shock can be reduced if such grounds are removed during installation and maintenance (applicable to equipment and remote battery supplies not having a grounded supply circuit).

Failure to follow these instructions will result in death or serious injury.

⚠️⚠️ DANGER

HAZARD OF ELECTRIC SHOCK, EXPLOSION, OR ARC FLASH

When replacing batteries, always replace with the same type and number of batteries or battery packs.

Failure to follow these instructions will result in death or serious injury.

NOTICE

RISK OF EQUIPMENT DAMAGE

- Wait until the system is ready to be powered up before installing batteries in the system. The time duration from battery installation until the UPS system is powered up must not exceed 72 hours or 3 days.
- Batteries must not be stored more than six months due to the requirement of recharging. If the UPS system remains de-energized for a long period, Schneider Electric recommends that you energize the UPS system for a period of 24 hours at least once every month. This charges the batteries, thus avoiding irreversible damage.

Failure to follow these instructions can result in equipment damage.

Specifications

Specifications for Maintenance Bypass Cabinet with Input Transformer (GVSBPIT25, GVSBPIT50, GVSBPIT75)

UPS rating	10 kW	15 kW	20 kW	25 kW	30 kW	40 kW	50 kW	60 kW	75 kW
Input voltage (V)	480/600								
Input connections	3-wire (L1, L2, L3, PE)								
Nominal input current (A)	13/10	19/15	26/20	32/26	38/31	51/41	64/51	82/67	100/81
Maximum input current (A)	15/12	23/16	31/25	38/31	46/37	61/49	77/61	95/75	115/92
Output connections	4-wire (L1, L2, L3, N, PE)								
Output voltage (V)	208								
Nominal output current (A)	28	42	56	69	83	111	139	167	208
Frequency (Hz)	60								
Circuit breaker interrupting ratings (kA)	100 at 240 V (for UIB/MBB/UOB)								
Continuous operation limited to maximum 110% load.									

Trip Settings for Maintenance Bypass Cabinet with Input Transformer

NOTE: Ir, tr, and li must be set during installation. Set the breaker settings per system kW rating as listed in the table below. Changing the settings to other than the listed settings will change the 125% and 150% overload operation, and will impact system performance.

UPS rating	Breaker type	Ir setting	Tr at 6 Ir setting	Ir setting	Tr at 6 Ir setting	li (x In) setting
	UIB/MBB/UOB	UIB		MBB/UOB		UIB/MBB/UOB
10 kW	HJF36150CU31X	50	0.5	50	0.5	1.5
15 kW	HJF36150CU31X	60	0.5	50	4	1.5
20 kW	HJF36150CU31X	80	0.5	70	4	1.5
25 kW	HJF36150CU31X	100	0.5	80	4	1.5
30 kW	JJF36250CU31X	110	4	100	4	1.5
40 kW	JJF36250CU31X	150	4	150	4	1.5
50 kW	JJF36250CU31X	200	0.5	175	2	1.5
60 kW	JJF36250CU31X	250	4	225	1	2
75 kW	JJF36250CU31X	250	4	250	2	2

Recommended Upstream Protection for Maintenance Bypass Cabinet with Input Transformer

For 480 V Input

UPS rating	Breaker type	Ir setting	Tr at 6 Ir setting	Ii (x In) setting
10 kW	HJL36060U31X	15	4	6
15 kW	HJL36060U31X	25	4	6
20 kW	HJL36060U31X	30	4	6
25 kW	HJL36060U31X	35	4	6
30 kW	HJL36060U31X	45	4	12
40 kW	HJL36060U31X	60	4	12
50 kW	HJL36100U31X	70	4	8
60 kW	JJL36250CU31X	100	0.5	2
75 kW	JJL36250CU31X	100	0.5	2

For 600 V Input

UPS rating	Breaker type	Ir setting	Tr at 6 Ir setting	Ii (x In) setting
10 kW	HJL36060U31X	15	1	6
15 kW	HJL36060U31X	20	4	6
20 kW	HJL36060U31X	25	4	6
25 kW	HJL36060U31X	30	4	6
30 kW	HJL36060U31X	35	8	12
40 kW	HJL36060U31X	45	8	12
50 kW	HJL36060U31X	60	4	12
60 kW	JJL36250CU31X	100	0.5	2
75 kW	JJL36250CU31X	100	0.5	2

Recommended Cable Sizes for Maintenance Bypass Cabinet with Input Transformer

⚡⚠ **DANGER**

HAZARD OF ELECTRIC SHOCK, EXPLOSION, OR ARC FLASH

All wiring must comply with all applicable national and/or electrical codes. The maximum allowable cable size is 4/0 AWG.

Failure to follow these instructions will result in death or serious injury.

NOTE: Overcurrent protection and cable lugs are to be provided by others.

Cable sizes in this manual are based on Table 310.15 (B)(16) of the National Electrical Code (NEC) with the following assertions:

- 90 °C (194 °F) conductors (75 °C (167 °F) termination)
- An ambient temperature of 30 °C (86 °F)
- Use of copper or aluminum conductors

If the ambient temperature is greater than 30 °C (86 °F), larger conductors are to be selected in accordance with the correction factors of the NEC.

Equipment grounding conductors/Protective Earth (PE in this manual) are sized in accordance with NEC Article 250.122 and Table 250.122.

Copper

UPS rating	10 kW	15 kW	20 kW	25 kW	30 kW	40 kW	50 kW	60 kW	75 kW
Input phases (AWG/kcmil)	8	8	8	8	4	4	4	3	1
Input PE (AWG/kcmil)	10	10	10	10	10	8	8	6	6
Output phases (AWG/kcmil)	8	8	4	4	3	1	2/0	3/0	4/0
Output PE (AWG/kcmil)	10	10	8	8	8	6	6	4	4
Neutral (AWG/kcmil) ¹	8	4	2	1	1/0	3/0	2 x 1	2 x 1/0	2 x 3/0
DC+/DC- (AWG/kcmil)	10	6	4	4	2	1/0	1/0	4/0	2 x 1
DC PE (AWG/kcmil)	10	10	8	8	6	6	6	4	4

Aluminum

UPS rating	10 kW	15 kW	20 kW	25 kW	30 kW	40 kW	50 kW	60 kW	75 kW
Input phases (AWG/kcmil)	6	6	6	6	2	2	2	1	
Input PE (AWG/kcmil)	8	8	8	8	8	6	6	4	
Output phases (AWG/kcmil)	6	6	3	2	1	3/0	4/0	2 x 1	
Output PE (AWG/kcmil)	8	8	6	6	6	4	4	2	
Neutral (AWG/kcmil) ¹	6	3	1	2/0	3/0	2 x 1	2 x 2/0	2 x 3/0	
DC+/DC- (AWG/kcmil)	8	4	3	2	1/0	2/0	2/0		
DC PE (AWG/kcmil)	8	8	6	6	4	4	4		

NOTE: DC cables are only connected in the maintenance bypass cabinet in top cable entry systems. In bottom cable entry systems, the DC cables are connected directly in the UPS.

NOTE: The DC cable sizes given here are recommendations – Always follow the specific instructions in the battery solution documentation for DC cable sizes.

1. Neutral conductor is sized to handle 1.73 times phase current in case of high harmonic content from non-linear loads. If few or no harmonic currents are expected, neutral conductor can be sized as phase conductor.

Specifications for Maintenance Bypass Cabinet with Output Transformer (GVSBPOT50, GVSBPOT100, GVSBPOT150)

UPS rating	20 kW	30 kW	40 kW	50 kW	60 kW	80 kW	100 kW	120 kW	150 kW
Input voltage (V)	480								
Input connections	3-wire (L1, L2, L3, PE)								
Nominal input current (A)	25	37	50	62	74	99	124	154	190
Maximum input current (A)	30	45	60	74	89	119	149	180	226
Output connections	4-wire (L1, L2, L3, N, PE)								
Output voltage (V)	208								
Nominal output current (A)	56	83	111	139	167	222	278	333	416
Frequency (Hz)	60								
Circuit breaker interrupting ratings (kA)	65 at 480 V (for UIB/MBB/UOB)								

Trip Settings for Maintenance Bypass Cabinet with Output Transformer

NOTE: The trip settings must be set during installation. Set the breaker settings per system kW rating as listed in the table below. Changing the settings to other than the listed settings will change the 125% and 150% overload operation, and will impact system performance.

UPS rating	Breaker type		Ir setting	Tr at 6 Ir setting	li (x In) setting	Ir setting	Tr at 6 Ir setting	li (x In) setting
	UIB	MBB/UOB	UIB			MBB/UOB		
20 kW	HJF36150CU31X	HJF36150CU31X	50	0.5	6	50	2	6
30 kW	HJF36150CU31X	HJF36150CU31X	60	0.5	6	50	2	6
40 kW	HJF36150CU31X	HJF36150CU31X	80	0.5	6	60	4	6
50 kW	HJF36150CU31X	HJF36150CU31X	90	0.5	6	70	4	6
60 kW	JJF36250CU31X	HJF36150CU31X	100	0.5	6	90	4	8
80 kW	JJF36250CU31X	HJF36150CU31X	150	0.5	6	125	2	8
100 kW	JJF36250CU31X	HJF36150CU31X	175	0.5	6	150	2	8
120 kW	JJF36250CU31X	JJF36250CU31X	200	0.5	8	175	2	8
150 kW	JJF36250CU31X	JJF36250CU31X	250	0.5	8	225	2	8

Recommended Upstream Protection for Maintenance Bypass Cabinet with Output Transformer

For 208 V Input

UPS rating	Breaker type	Ir setting	Tr at 6 Ir setting	li (x In) setting
20 kW	HJL36150CU31X	50	0.5	2
30 kW	HJL36150CU31X	60	0.5	2
40 kW	HJL36150CU31X	80	0.5	2
50 kW	HJL36150CU31X	90	0.5	2
60 kW	JJL36250CU31X	100	0.5	2
80 kW	JJL36250CU31X	150	0.5	2
100 kW	JJL36250CU31X	175	0.5	2
120 kW	JJL36250CU31X	200	0.5	2
150 kW	JJL36250CU31X	250	0.5	2

Recommended Cable Sizes for Maintenance Bypass Cabinet with Output Transformer

DANGER

HAZARD OF ELECTRIC SHOCK, EXPLOSION, OR ARC FLASH

All wiring must comply with all applicable national and/or electrical codes. The maximum allowable cable size is 300 kcmil.

Failure to follow these instructions will result in death or serious injury.

NOTE: Overcurrent protection and cable lugs are to be provided by others.

Cable sizes in this manual are based on Table 310.15 (B)(16) of the National Electrical Code (NEC) with the following assertions:

- 90 °C (194 °F) conductors (75 °C (167 °F) termination)
- An ambient temperature of 30 °C (86 °F)
- Use of copper or aluminum conductors

If the ambient temperature is greater than 30 °C (86 °F), larger conductors are to be selected in accordance with the correction factors of the NEC.

Equipment grounding conductors/Protective Earth (PE in this manual) are sized in accordance with NEC Article 250.122 and Table 250.122.

Copper

UPS rating	20 kW	30 kW	40 kW	50 kW	60 kW	80 kW	100 kW	120 kW	150 kW
Input phases (AWG/kcmil)	8	6	4	3	3	1/0	2/0	3/0	2 x 1
Input PE (AWG/kcmil)	10	10	8	8	8	6	6	4	3
Output phases (AWG/kcmil)	6	3	1	1/0	2/0	2 x 1	2 x 1/0	2 x 2/0	2 x 4/0
Output PE (AWG/kcmil)	10	8	6	6	6	4	4	2	1
Neutral (AWG/kcmil) 2	3	1/0	3/0	2 x 1	2 x 1/0	2 x 3/0	2 x 250	2 x 300	3 x 4/0

2. Neutral conductor is sized to handle 1.73 times phase current in case of high harmonic content from non-linear loads. If few or no harmonic currents are expected, neutral conductor can be sized as phase conductor.

Copper (Continued)

UPS rating	20 kW	30 kW	40 kW	50 kW	60 kW	80 kW	100 kW	120 kW	150 kW
DC+/DC- (AWG/kcmil)	4	3	1/0	1/0	2/0	4/0	300	2 x 2/0	2 x 3/0
DC PE (AWG/kcmil)	8	6	6	6	6	4	4	2	1

NOTE: Aluminum cables are not supported for 100-150 kW maintenance bypass cabinet with output transformer.

Aluminum

UPS rating	20 kW	30 kW	40 kW	50 kW	60 kW	80 kW
Input phases (AWG/kcmil)	6	4	2	2	1	3/0
Input PE (AWG/kcmil)	8	8	6	6	6	4
Output phases (AWG/kcmil)	4	2	3/0	3/0	4/0	2 x 1/0
Output PE (AWG/kcmil)	8	6	4	4	4	2
Neutral (AWG/kcmil) 3	1	3/0	2 x 1/0	2 x 2/0	2 x 3/0	2 x 250
DC+/DC- (AWG/kcmil)	3	1	2/0	2/0	4/0	300
DC PE (AWG/kcmil)	6	4	4	4	4	2

NOTE: DC cables are only connected in the maintenance bypass cabinet in top cable entry systems. In bottom cable entry systems, the DC cables are connected directly in the UPS.

NOTE: The DC cable sizes given here are recommendations – Always follow the specific instructions in the battery solution documentation for DC cable sizes.

3. Neutral conductor is sized to handle 1.73 times phase current in case of high harmonic content from non-linear loads. If few or no harmonic currents are expected, neutral conductor can be sized as phase conductor.

Recommended Bolt and Lug Sizes

NOTICE

RISK OF EQUIPMENT DAMAGE

Use only UL approved compression cable lugs.

Failure to follow these instructions can result in equipment damage.

Copper — One Hole Cable Lugs

Cable size	Bolt size	Cable lug type	Crimping tool	Die
10 AWG	M8 x 35 mm	LCA10-56-L	NA	NA
8 AWG	M8 x 35 mm	LCA8-56-L	CT-720	CD-720-1 Red P21
6 AWG	M8 x 35 mm	LCA6-56-L	CT-720	CD-720-1 Blue P24
4 AWG	M8 x 35 mm	LCA4-56-L	CT-720	CD-720-1 Gray P29
3 AWG	M8 x 35 mm	LCA4-56-L	CT-720	CD-720-1 Gray P29
2 AWG	M8 x 35 mm	LCA2-56-Q	CT-720	CD-720-1 Brown P33
1 AWG	M8 x 35 mm	LCA1-56-E	CT-720	CD-720-2 Green P37
1/0 AWG	M8 x 35 mm	LCA1/0-56-X	CT-720	CD-720-2 Pink P42
2/0 AWG	M8 x 35 mm	LCA2/0-56-X	CT-720	CD-720-2 Black P45
3/0 AWG	M8 x 35 mm	LCA3/0-56-X	CT-720	CD-720-2 Orange P50
4/0 AWG	M8 x 35 mm	LCA4/0-56-X	CT-720	CD-720-3 Purple P54
250 kcmil	M8 x 35 mm	LCA250-56-X	CT-720	CD-720-3 Yellow P62
300 kcmil	M8 x 35 mm	LCA300-56-X	CT-720	CD-720-4 White P66

Aluminum — One Hole Cable Lugs

Cable size	Bolt size	Cable lug type	Crimping tool	Die
6 AWG	M8 x 35 mm	LAA6-56-x	CT-720	CD-720-1 Gray P29
4 AWG	M8 x 35 mm	LAA4-56-x	CT-720	CD-720-2 Green P37
2 AWG	M8 x 35 mm	LAA2-56-x	CT-720	CD-720-2 Pink P42
1 AWG	M8 x 35 mm	LAA1-56-X	CT-720	CD-720-2 Gold P45
1/0 AWG	M8 x 35 mm	LAA1/0-56-5	CT-720	CD-720-2 Tan P50
2/0 AWG	M8 x 35 mm	LAA2/0-38-5	CT-720	CD-720-3 Olive P54
3/0 AWG	M8 x 35 mm	LAA3/0-38-5	CT-720	CD-720-3 Ruby P60
4/0 AWG	M8 x 35 mm	LAA4/0-38-5	CT-720	CD-720-4 White P66
250 kcmil	M8 x 35 mm	LAA250-38-5	CT-720	CD-720-5 Red P71
300 kcmil	M8 x 35 mm	LAA300-38-2	CT-720	CD-720-6 Blue P76

Copper — Two Hole Cable Lugs

Cable size	Bolt size	Cable lug type ⁴	Crimping tool	Die
6 AWG	M8 x 35 mm	LCC6-12-L	CT-930	CD-920-6 Blue P24
4 AWG	M8 x 35 mm	LCC4-12-L	CT-930	CD-920-4 Gray P29
3 AWG	M8 x 35 mm			
2 AWG	M8 x 35 mm	LCC2-12-Q	CT-930	CD-920-2 Brown P33
1 AWG	M8 x 35 mm	LCC1-12-E	CT-930	CD-920-1 Green P37

4. Use oversized M8 flat washer.

Copper — Two Hole Cable Lugs (Continued)

Cable size	Bolt size	Cable lug type ⁵	Crimping tool	Die
1/0 AWG	M8 x 35 mm	LCC1/0-12-X	CT-930	CD-920-1/0 Pink P42
2/0 AWG	M8 x 35 mm	LCC2/0-12-X	CT-930	CD-920-2/0 Black P45
3/0 AWG	M8 x 35 mm	LCC3/0-12-X	CT-930	CD-920-3/0 Orange P50
4/0 AWG	M8 x 35 mm	LCC4/0-12-X	CT-930	CD-920-4/0 Purple P54
250 kcmil	M8 x 35 mm	LCC250-12-X	CT-930	CD-920-250 Yellow P62
300 kcmil	M8 x 35 mm	LCC300-12-X	CT-930	CD-920-300 White P66

Aluminum — Two Hole Cable Lugs

Cable size	Bolt size	Cable lug type ⁵	Crimping tool	Die
2/0 AWG	M8 x 35 mm	LAB2/0-12-5	CT-720	CD-720-3 Olive P54
3/0 AWG	M8 x 35 mm	LAB3/0-12-5	CT-720	CD-720-3 Ruby P60
4/0 AWG	M8 x 35 mm	LAB4/0-12-5R	CT-720	CD-720-4 White P66
250 kcmil	M8 x 35 mm	LAB250-12-5	CT-720	CD-720-5 Red P71
300 kcmil	M8 x 35 mm	LAB300-12-2	CT-720	CD-720-6 Blue P76

Torque Specifications

Bolt size	Torque
M4	1.7 Nm (1.25 lb-ft / 15 lb-in)
M5	2.2 Nm (1.62 lb-ft / 19.5 lb-in)
M6	5 Nm (3.69 lb-ft / 44.3 lb-in)
M8	17.5 Nm (12.91 lb-ft / 154.9 lb-in)
M10	30 Nm (22 lb-ft / 194.7 lb-in)

Maintenance Bypass Cabinet with Transformer Weights and Dimensions

Commercial reference	Weight kg (lbs)	Height mm (in)	Width mm (in)	Depth mm (in)
GVSBPIT25	395 (870.83)	1485 (58.46)	600 (23.62)	836 (32.91)
GVSBPIT50	530 (1168.45)	1485 (58.46)	600 (23.62)	836 (32.91)
GVSBPIT75	620 (1364)	1485 (58.46)	600 (23.62)	836 (32.91)
GVSBPOT50	530 (1168.45)	1485 (58.46)	600 (23.62)	836 (32.91)
GVSBPOT100	645 (1421.98)	1485 (58.46)	600 (23.62)	836 (32.91)
GVSBPOT150	890 (1958)	1485 (58.46)	800 (31.50)	836 (32.91)

5. Use oversized M8 flat washer.

Clearance

NOTE: Clearance dimensions are published for airflow and service access only. Consult with the local safety codes and standards for additional requirements in your local area.

Front View of the UPS and the Maintenance Bypass Cabinet

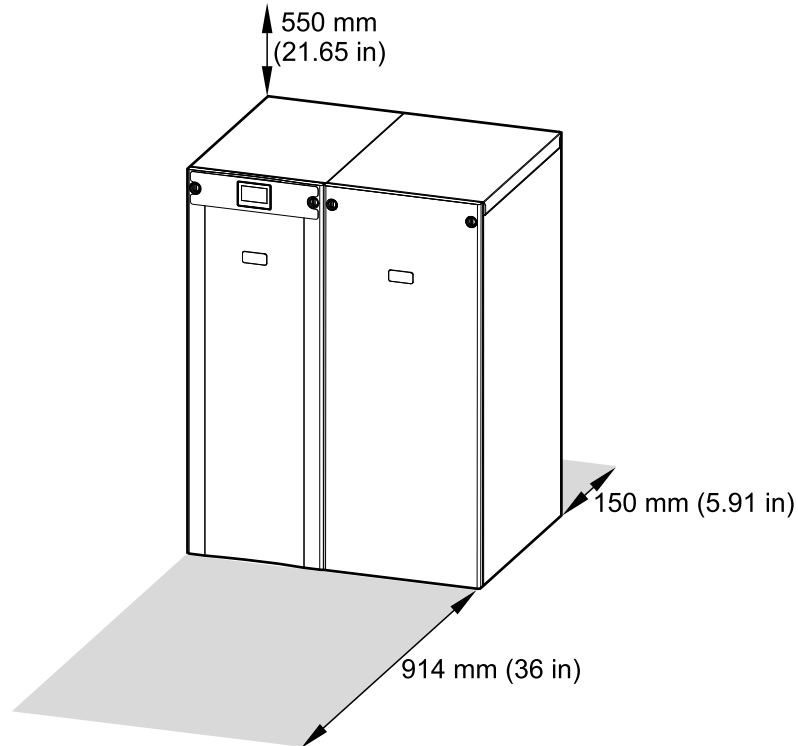

Environment

	Operating	Storage
Temperature	0 °C to 40 °C (32 °F to 104 °F)	-25 °C to 55 °C (-13 °F to 131 °F)
Relative humidity	0 - 95% non-condensing	0-95% non-condensing
Elevation	Designed for operation in 0-3000 m (0-10000 feet) elevation. Power derating required from 1000-3000 m (3300-10000 feet): Up to 1000 m (3300 feet): 1.000 Up to 1500 m (5000 feet): 0.975 Up to 2000 m (6600 feet): 0.950 Up to 2500 m (8300 feet): 0.925 Up to 3000 m (10000 feet): 0.900	
Protection class	IP20	
Color	RAL 9003, gloss level 85%	

System Overview

UIB	Unit input breaker
MBB	Maintenance bypass breaker
IMB	Internal maintenance breaker
UOB	Unit output breaker

UPS System with Maintenance Bypass Cabinet with Input Transformer

NOTE: The internal maintenance breaker IMB* in the UPS cannot be used in a system with a maintenance bypass cabinet with transformer and must be padlocked in the open position.

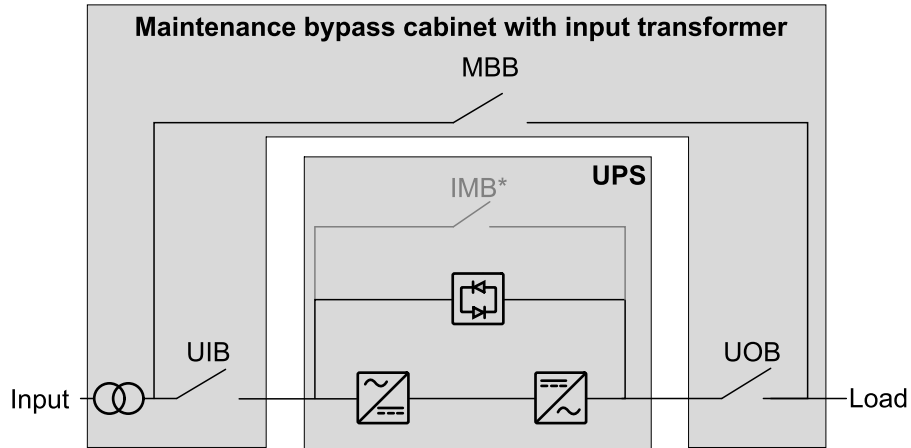

UPS System with Maintenance Bypass Cabinet with Output Transformer

NOTE: The internal maintenance breaker IMB* in the UPS cannot be used in a system with a maintenance bypass cabinet with transformer and must be padlocked in the open position.

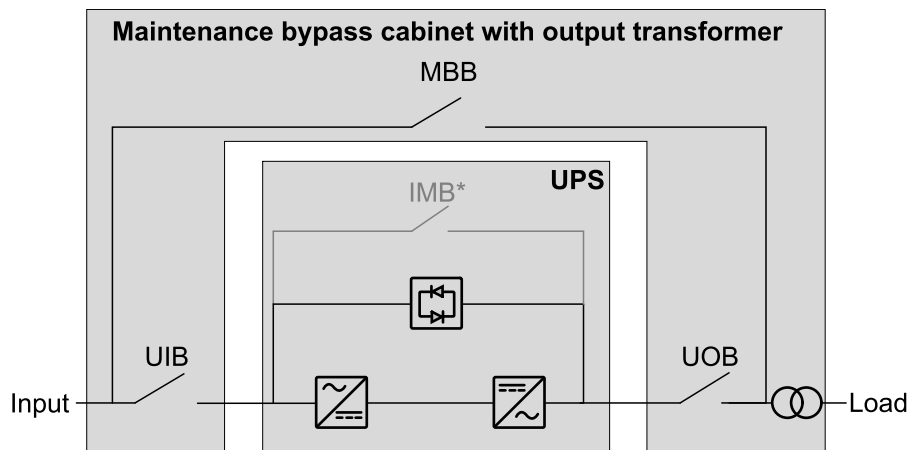

Installation Procedure

Top Cable Entry System

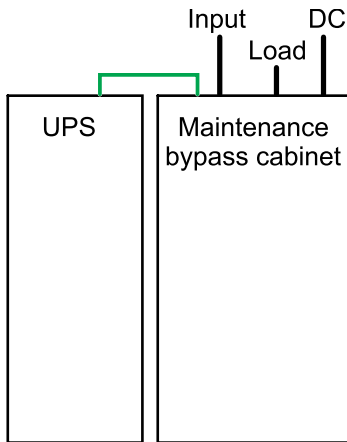

— Signal cable
— Power cable

Bottom Cable Entry System

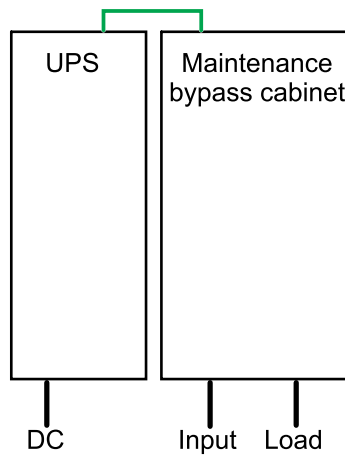

1. Follow the unpacking label on the cabinet packaging or see *Unpack the Maintenance Bypass Cabinet*, page 22 depending on your model.
2. *Prepare the Maintenance Bypass Cabinet for Cables*, page 25.
3. *Install the Seismic Anchoring (Option)*, page 27.
4. *Interconnect the UPS and the Maintenance Bypass Cabinet*, page 29.
5. Perform one of the following:
 - *Connect the Power Cables in a Maintenance Bypass Cabinet with Input Transformer*, page 33, or
 - *Connect the Power Cables in a Maintenance Bypass Cabinet with Output Transformer*, page 34.
6. *Connect the Signal Cables*, page 35.
7. *Final Installation*, page 37.
8. Follow the UPS installation manual to connect the preinstalled power cables from the maintenance bypass cabinet in the UPS and to complete the rest of the UPS installation.

Receiving

External Inspection

When the shipment arrives, inspect the shipping material for any signs of damage or mishandling. Check tilt and impact indicators. Do not attempt to install the system if a damage is apparent. If any damage is noted, contact Schneider Electric and file a damage claim with the shipping agency within 24 hours.

Compare the components of the shipment with the bill of lading. Report any missing items to the carrier and to Schneider Electric immediately.

Verify that labelled units match the order confirmation.

Unpack the Maintenance Bypass Cabinet

NOTICE

RISK OF EQUIPMENT DAMAGE

Do not unpack the cabinet before the time of installation.

Failure to follow these instructions can result in equipment damage.

NOTICE

RISK OF EQUIPMENT DAMAGE

- Ensure that the floor is level and can support the weight of the jack when it carries the cabinet.
- Be careful not to damage the cabinets when using the jack.

Failure to follow these instructions can result in equipment damage.

1. Remove all the packaging, retrieve the installation kits, and save the protective packaging bag for later use.
2. Remove the front door.
3. Remove the left, right, and middle pallet parts.

Rear View

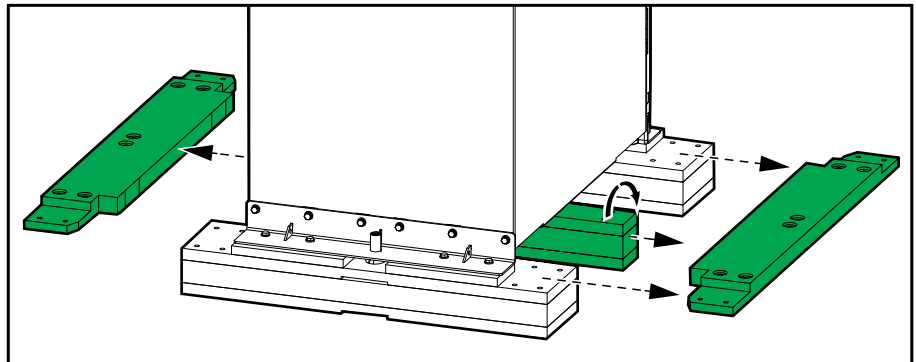

4. Remove the rear pallet part:
 - a. Place the floor protection plate under the pallet on the rear side of the cabinet.
 - b. Remove the bolts from the transportation bracket.
 - c. Place the jack into the transportation bracket hole and use a drilling machine to lift the cabinet up to the max height of the jack.

⚠ WARNING

HAZARD OF SERIOUS INJURY

Do not put your hands or feet under the cabinet while removing the pallet.

Failure to follow these instructions can result in death, serious injury, or equipment damage.

Rear View

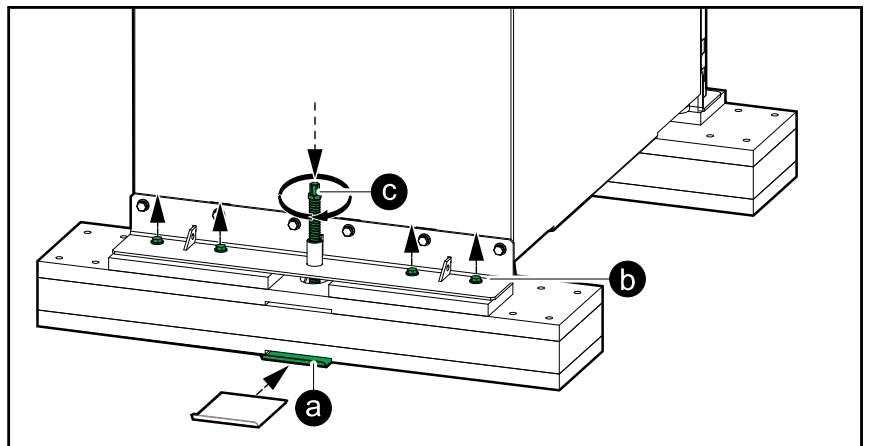

- d. Remove the rear pallet part.

Rear View

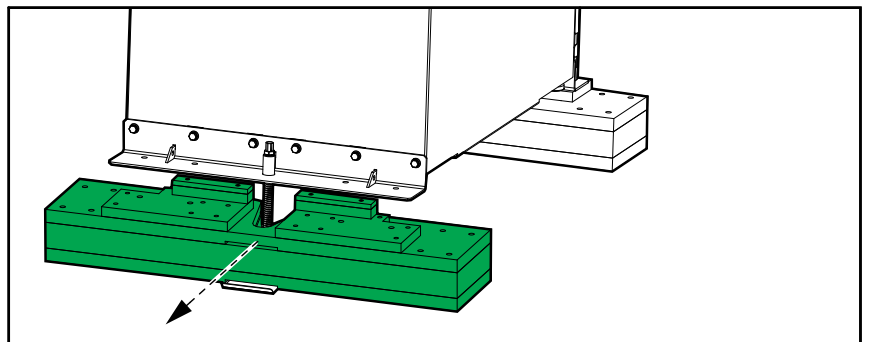

- e. Use the drilling machine on the jack to lower the cabinet down to the floor.

5. Remove the front pallet part:
 - a. Place the floor protection plate under the pallet on the front side of the cabinet.
 - b. Remove the bolts from the transportation bracket.
 - c. Install the small bracket for the jack on the front transportation bracket.
 - d. Place the jack into the transportation bracket hole and use a drilling machine to lift the cabinet up to the max height of the jack.

⚠ WARNING

HAZARD OF SERIOUS INJURY

Do not put your hands or feet under the cabinet while removing the pallet.

Failure to follow these instructions can result in death, serious injury, or equipment damage.

Front View

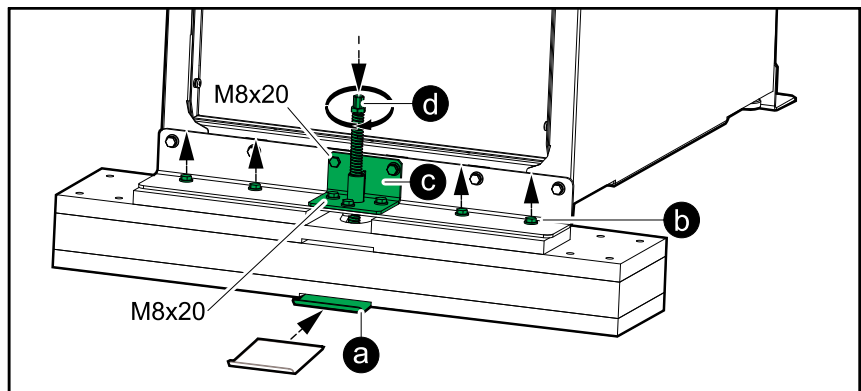

- e. Remove the front pallet part.
 - f. Use the drilling machine on the jack to lower the cabinet down to the floor.
6. Remove the front and rear transportation brackets and the floor protection plate.
7. Reinstall the front door.

Prepare the Maintenance Bypass Cabinet for Cables

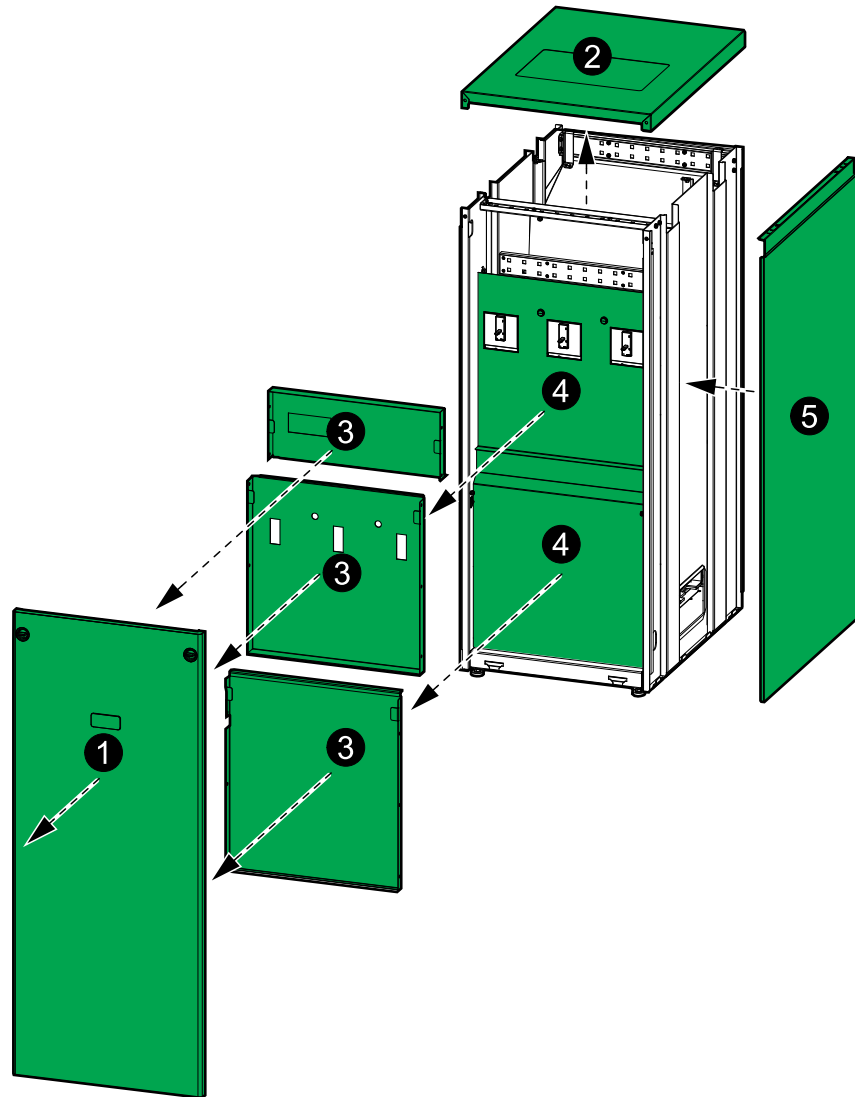

1. Remove the front panel from the maintenance bypass cabinet.
2. Remove the top cover from the maintenance bypass cabinet.
3. Remove the lower, middle, and upper front plates from the maintenance bypass cabinet.
4. Remove the transparent plates from the maintenance bypass cabinet.
5. Remove the right side panel from the UPS and reinstall the side panel on the right side of the maintenance bypass cabinet.
6. Remove the gland plate from the top or bottom of the maintenance bypass cabinet.

7. Drill or punch holes for power cables or conduits in the gland plate. Conduits are not provided.

⚠ DANGER**HAZARD OF ELECTRIC SHOCK, EXPLOSION, OR ARC FLASH**

Do not drill or cut holes for power cables or conduits with the gland plate installed and do not drill or cut holes in close proximity to the maintenance bypass cabinet.

Failure to follow these instructions will result in death or serious injury.

8. Reinstall the gland plate in the top cover or in the bottom of the maintenance bypass cabinet.

Install the Seismic Anchoring (Option)

Use the optional installation kits GVSOPT002 (shipped with the UPS) and GVSOPT008 or GVSOPT029 for this procedure.

1. Interconnect the rear anchors for the UPS and the maintenance bypass cabinet with the interconnection plate and four M8 bolts (provided).
2. Mount the rear anchor assembly to the floor. Use appropriate hardware for the floor type – the hole diameter in the rear anchor is $\varnothing 14$ mm.

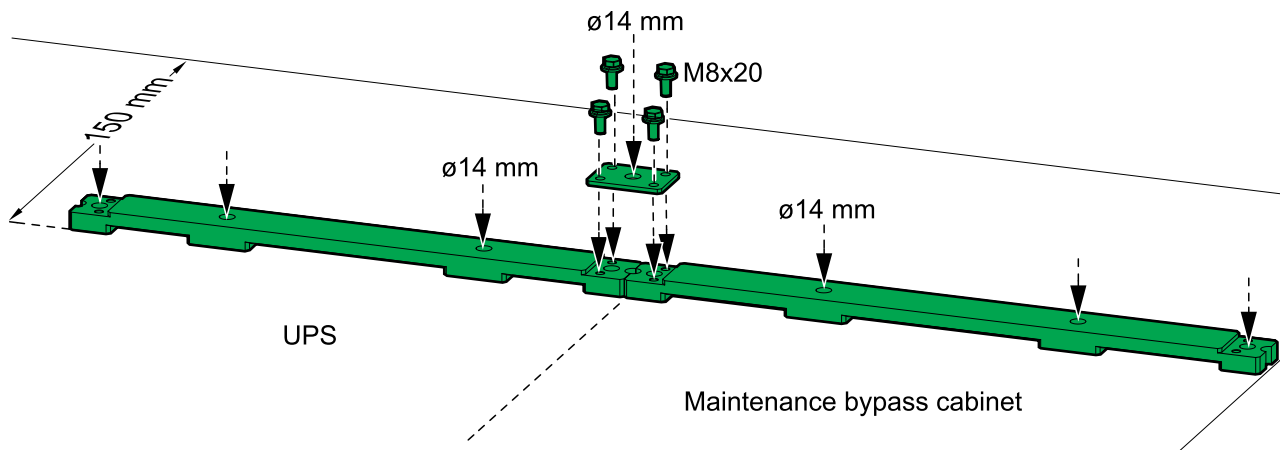

3. Install the rear anchoring brackets on the UPS and the maintenance bypass cabinet with the M8 bolts (provided).

Rear View of the Maintenance Bypass Cabinet

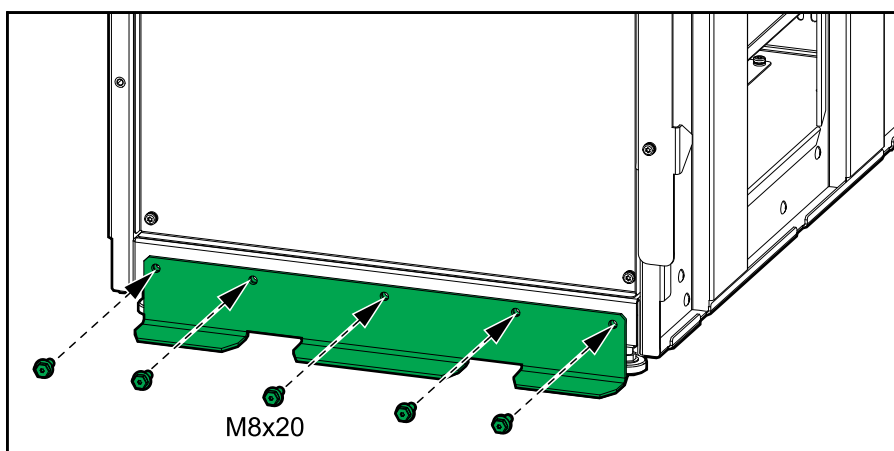

4. Push the maintenance bypass cabinet into position so the rear anchoring bracket connects to the rear anchor. The front anchoring bracket is installed in the final installation steps.

NOTE: Do not push the UPS into position yet.

Rear View of the Maintenance Bypass Cabinet

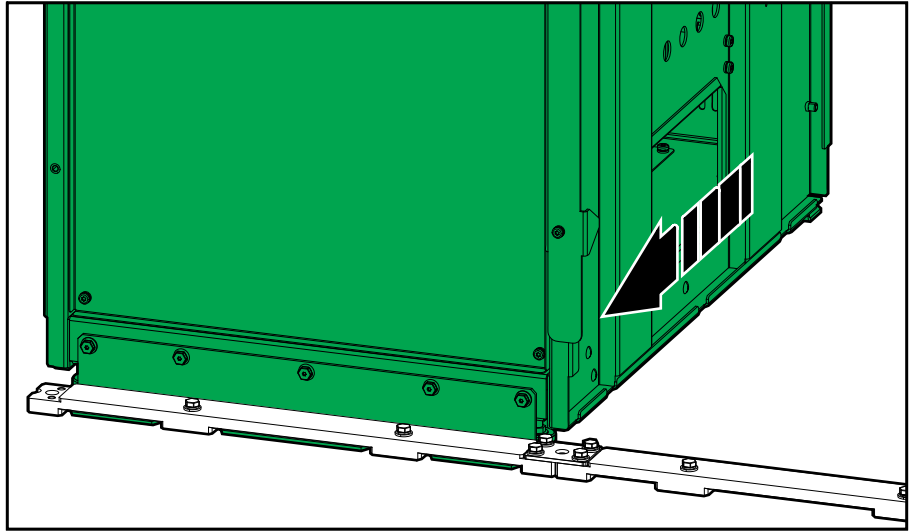

Interconnect the UPS and the Maintenance Bypass Cabinet

1. Reinstall the top cover on the maintenance bypass cabinet with four screws.
2. Remove the three M6 x 16 mm interconnection screws from the left side of the maintenance bypass cabinet. Save for interconnection.
3. Position the UPS close to the maintenance bypass cabinet with a little free space between the cabinets.
4. **For bottom cable entry only:** Remove the preinstalled DC cables from the maintenance bypass cabinet. DC cables are connected directly in the UPS for bottom cable entry.
5. Route the preinstalled power cables from the maintenance bypass cabinet into the UPS. These preinstalled power cables must be connected in the UPS – follow the UPS installation manual to connect them correctly.

Front View of the UPS and the Maintenance Bypass Cabinet

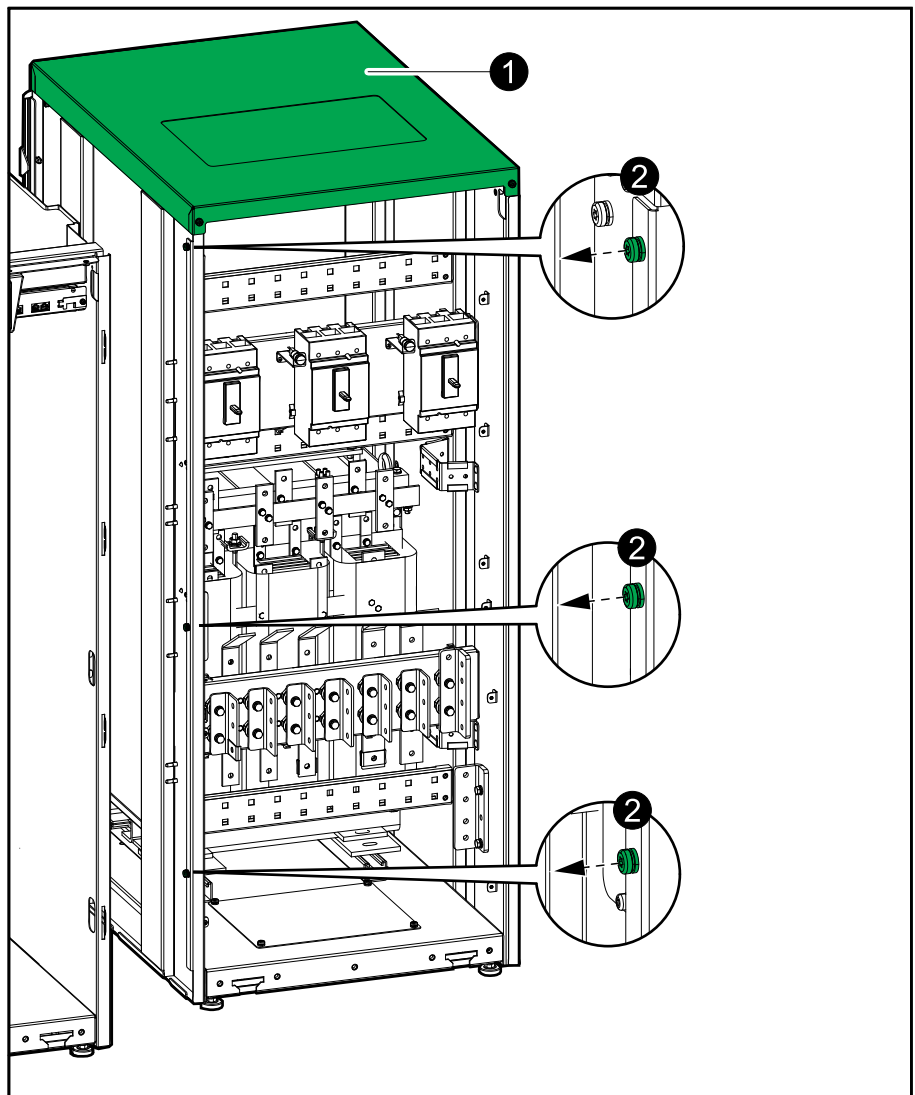

6. Push the UPS into place up against the maintenance bypass cabinet. The rear bracket on the maintenance bypass cabinet must connect to the UPS.

Rear View of the Maintenance Bypass Cabinet and the UPS

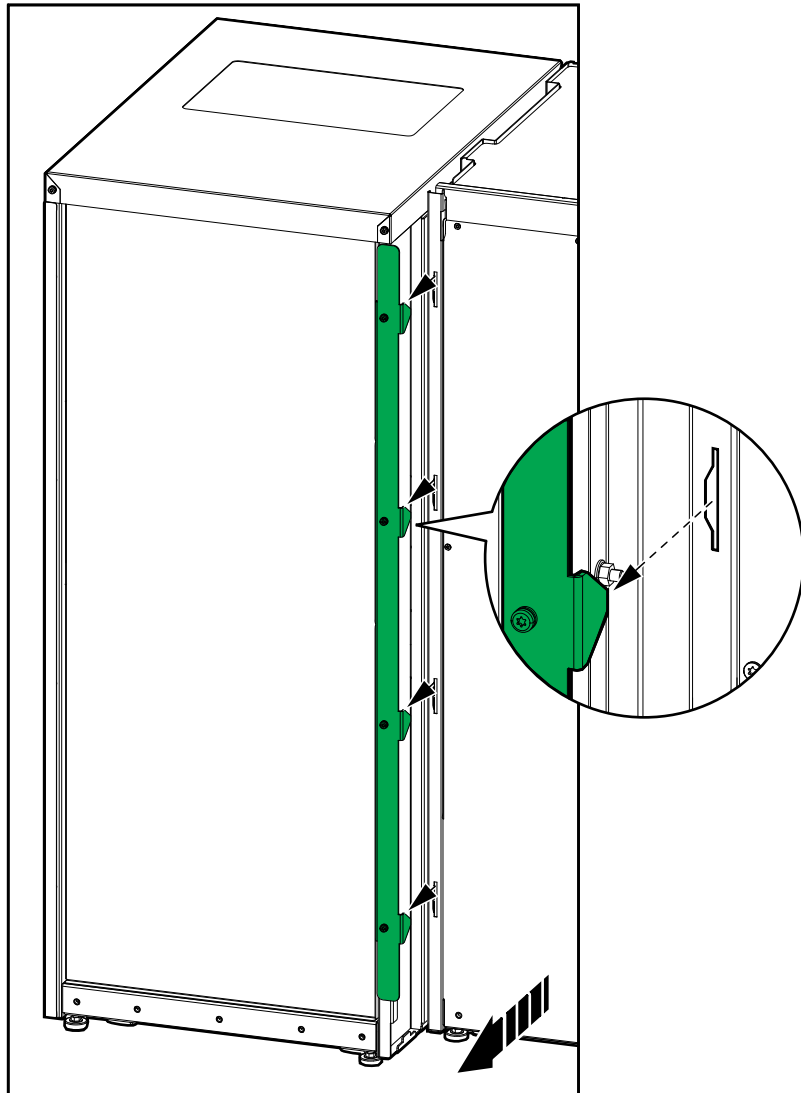

7. Install the three M6 x 16 mm interconnection screws between the UPS and the maintenance bypass cabinet as shown.

Front View of the UPS and the Maintenance Bypass Cabinet

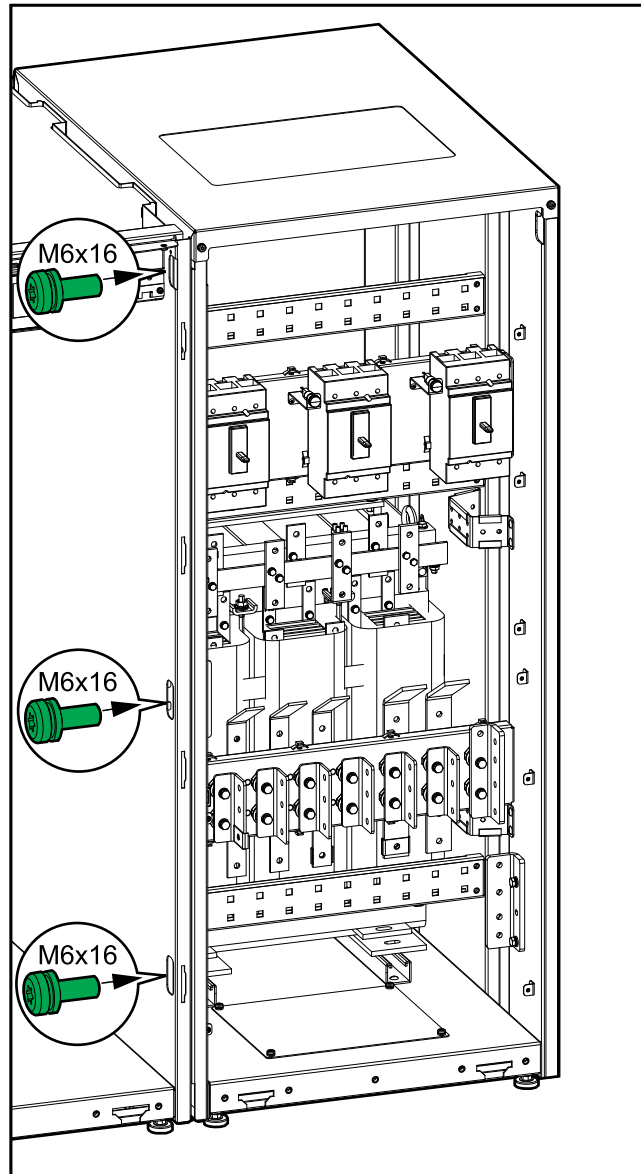

- Lower the front and rear leveling feet on the UPS and the maintenance bypass cabinet with a wrench until they connect with the floor. Use a bubble-leveler to check that the UPS and maintenance bypass cabinet are level.

Front View of the UPS

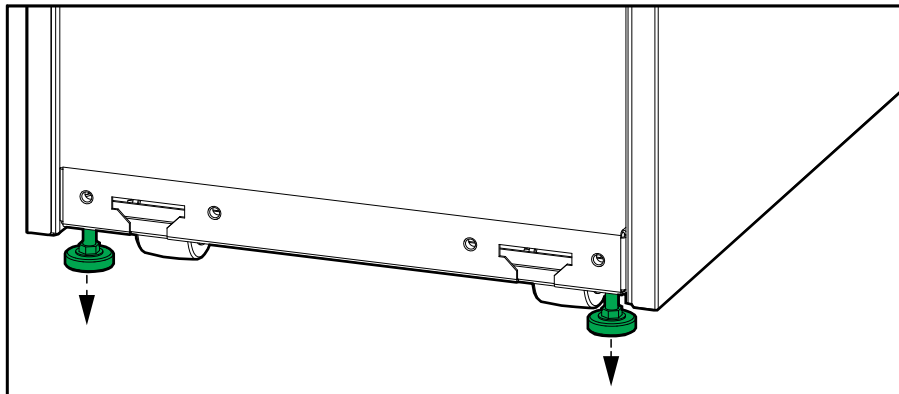

▲ CAUTION

TIP HAZARD

Do not move the cabinet after the leveling feet have been lowered.

Failure to follow these instructions can result in injury or equipment damage.

Connect the Power Cables in a Maintenance Bypass Cabinet with Input Transformer

NOTE: Route the input cables, load cables, and DC cables separately to avoid EMC disturbance.

NOTE: Route the power cables in front of the horizontal bracket in the top or bottom of the maintenance bypass cabinet to ensure correct separation from the transformer.

1. Perform one of the following:
 - **For 480 V input transformer:** Route the input cables through the top or bottom of the maintenance bypass cabinet and connect the input cables to the upper 480 V input busbars and the PE busbar.
 - **For 600 V input transformer:** Route the input cables through the top or bottom of the maintenance bypass cabinet and connect the input cables to the lower 600 V input busbars and the PE busbar.

Front View of Maintenance Bypass Cabinet with Input Transformer

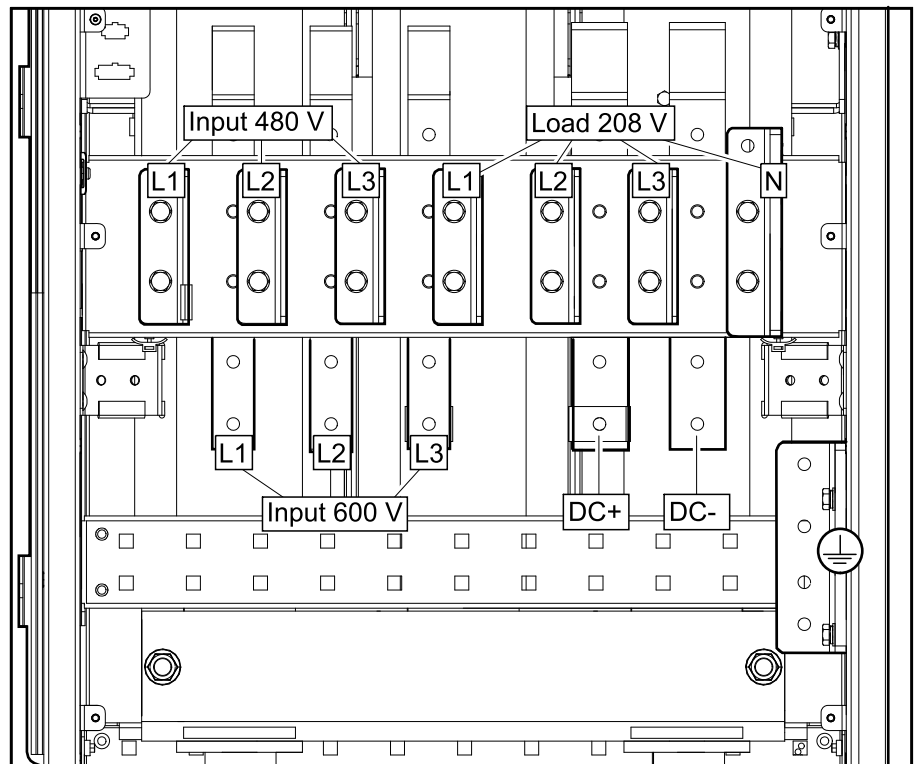

2. Route the load cables through the top or bottom of the maintenance bypass cabinet and connect to the load busbars, the N busbar, and the PE busbar.
3. Perform one of the following:
 - **For top cable entry:** Route the DC cables through the top of the maintenance bypass cabinet and connect to the DC busbars and the PE busbar.
 - **For bottom cable entry:** Route the DC cables through the bottom of the UPS. Follow the UPS installation manual to connect the DC cables.
4. Fasten the power cables to the horizontal bracket in the top or bottom of the maintenance bypass cabinet with cable ties.

Connect the Power Cables in a Maintenance Bypass Cabinet with Output Transformer

NOTE: Route the input cables, load cables, and DC cables separately to avoid EMC disturbance.

NOTE: Route the power cables in front of the horizontal bracket in the top or bottom of the maintenance bypass cabinet to ensure correct separation from the transformer.

1. Route the input cables through the top or bottom of the maintenance bypass cabinet and connect to the input busbars and the PE busbar.

Front View of Maintenance Bypass Cabinet with Output Transformer

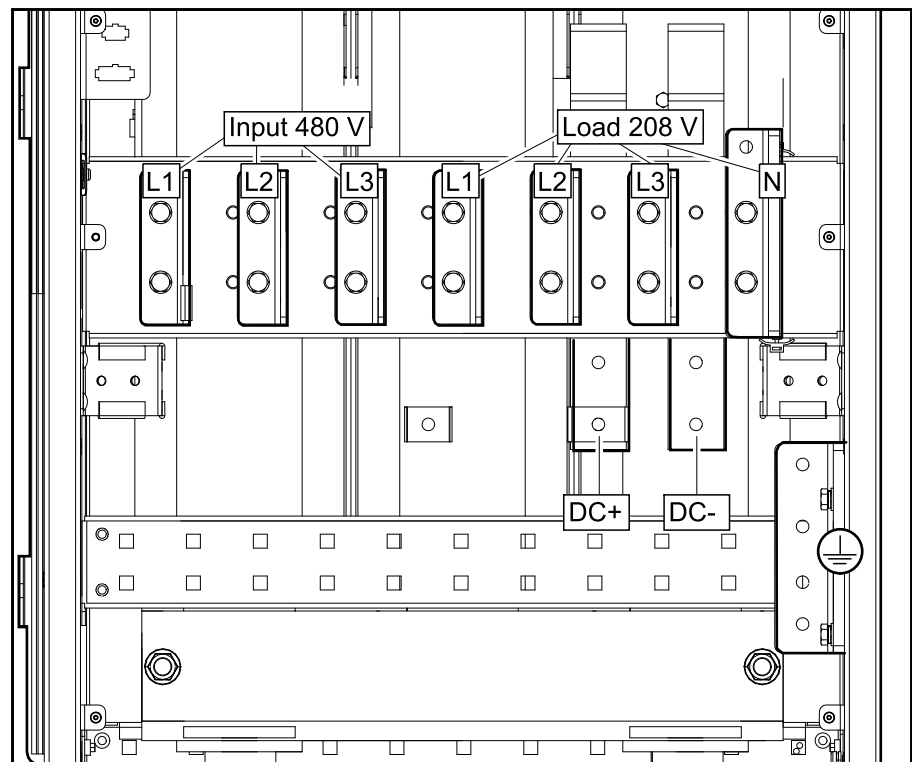

2. Route the load cables through the top or bottom of the maintenance bypass cabinet and connect to the load busbars, the N busbar, and the PE busbar.
3. Perform one of the following:
 - **For top cable entry:** Route the DC cables through the top of the maintenance bypass cabinet and connect to the DC busbars and the PE busbar.
 - **For bottom cable entry:** Route the DC cables through the bottom of the UPS. Follow the UPS installation manual to connect the DC cables.
4. Fasten the power cables to the horizontal bracket in the top or bottom of the maintenance bypass cabinet with cable ties.

Connect the Signal Cables

1. Unplug the three preconnected signal cables 0W49283, 0W49284, and 0W76723 from the maintenance bypass cabinet for easier cable routing.
2. Connect the Class 2/SELV signal cables 0W49283 (breaker indicator lights) and 0W76723 (transformer thermal sensor) to board 640-4864 in the UPS as shown.

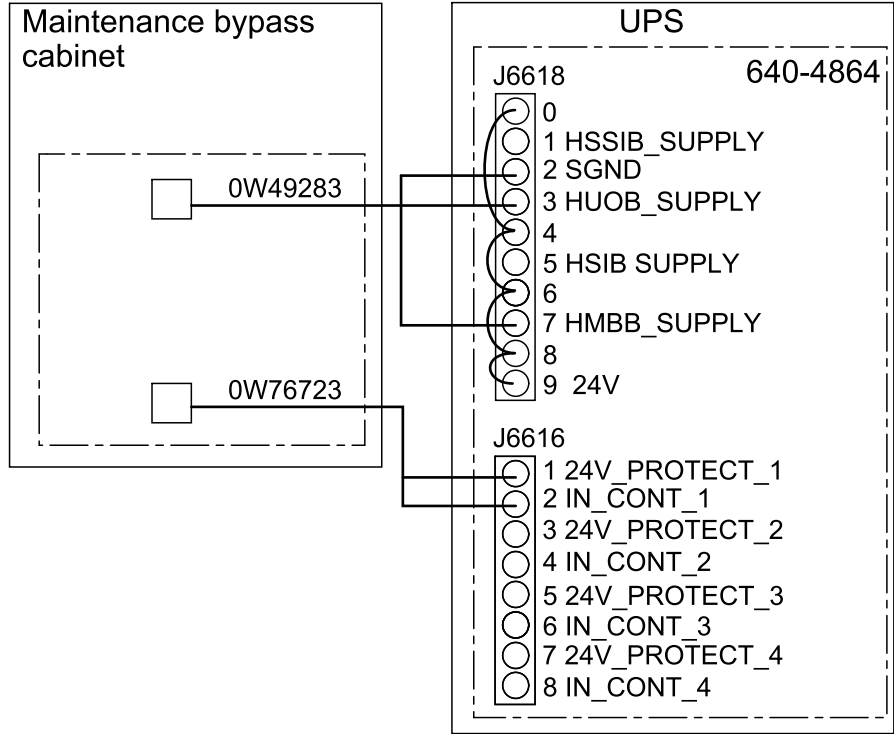

3. Connect the non-Class 2/non-SELV signal cable 0W49284 (breaker AUX switches) to board 640-4843 in the UPS as shown.

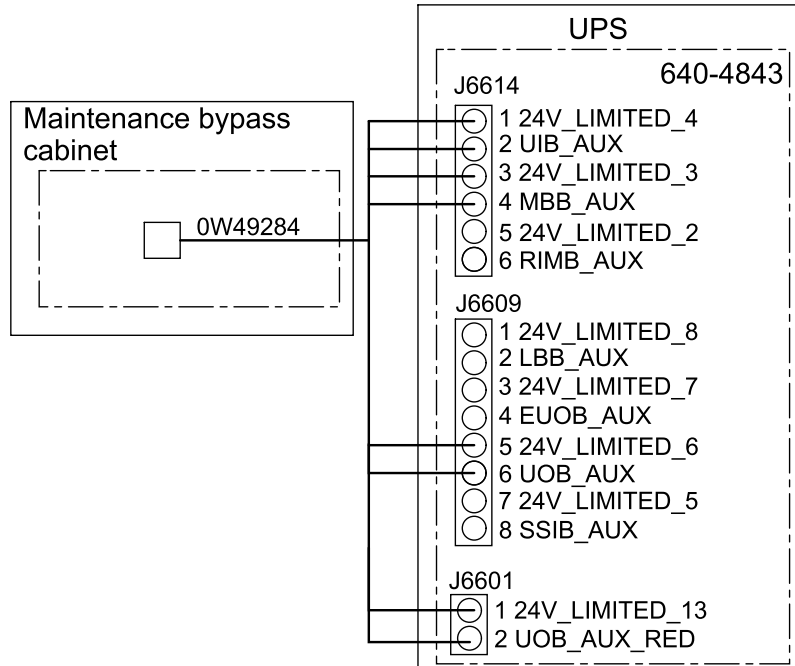

4. Route the signal cables down through the cable channel in the right side of the UPS and into the maintenance bypass cabinet through the cable entry opening.

NOTE: Route the signal cables as far away from the power cables as possible to avoid EMC disturbance.

Front View of the UPS and the Maintenance Bypass Cabinet

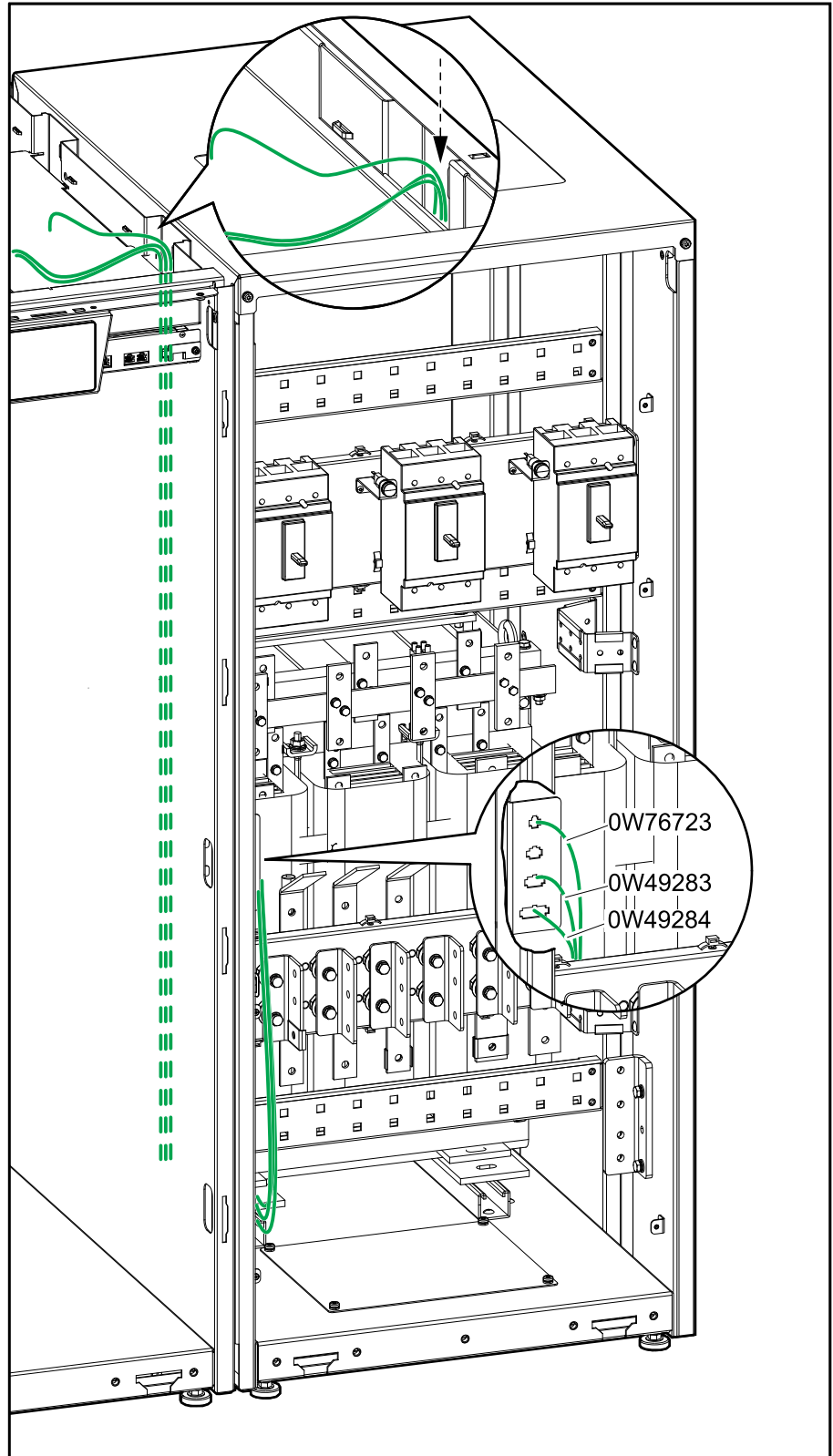

5. Reconnect the signal cables at the cable connection point in the maintenance bypass cabinet.

Final Installation

1. Reinstall the plates on the maintenance bypass cabinet:
 - a. Reinstall the lower transparent plate.
 - b. Reinstall the upper transparent plate.
 - c. Reinstall the lower front plate.
 - d. Reinstall the middle front plate.
 - e. Reinstall the upper front plate.

Front View of the Maintenance Bypass Cabinet

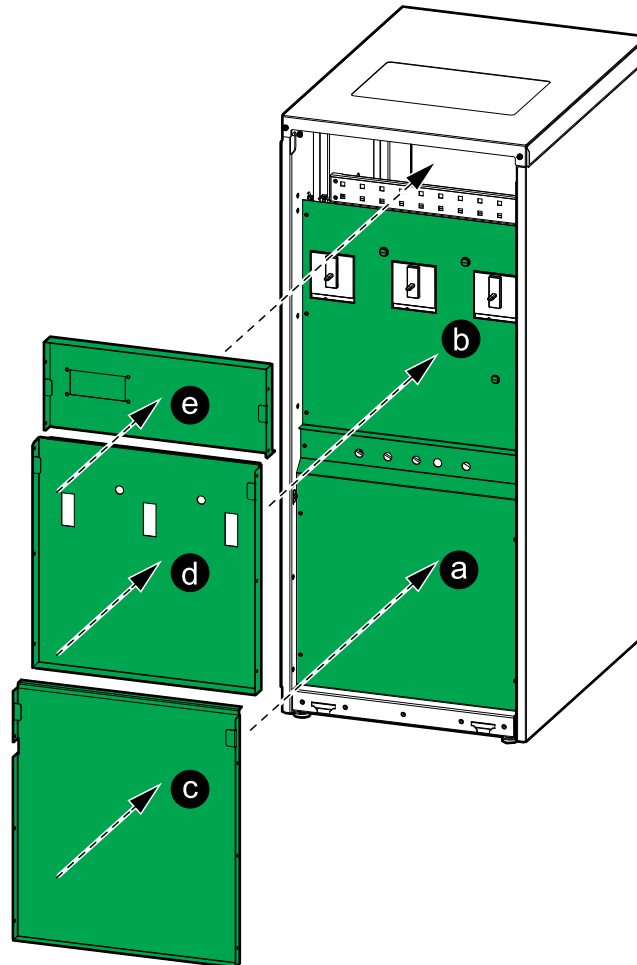

2. Only for seismic anchoring:

- a. Install the seismic front anchoring bracket on the maintenance bypass cabinet with the provided M8 bolts.
- b. Mount the seismic front anchoring bracket on the maintenance bypass cabinet to the floor. Use appropriate hardware for the floor type – the hole diameter in the front anchoring bracket is $\varnothing 18$ mm.

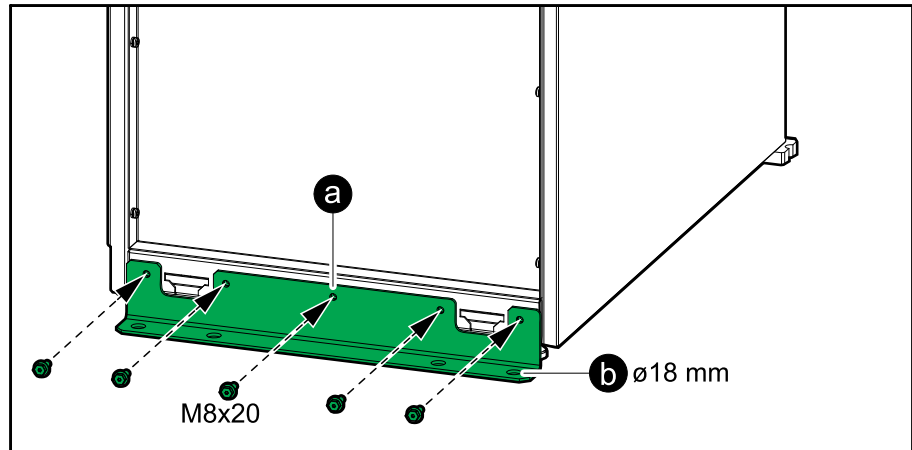
Front View of the Maintenance Bypass Cabinet

3. Reinstall the front panel on the maintenance bypass cabinet:
 - a. Insert the two tabs in the bottom of the front panel in the maintenance bypass cabinet at a tilted angle.
 - b. Reconnect the front panel strap to the maintenance bypass cabinet.
 - c. Close the front panel and lock with the two locking knobs.

Front Right View of the Maintenance Bypass Cabinet

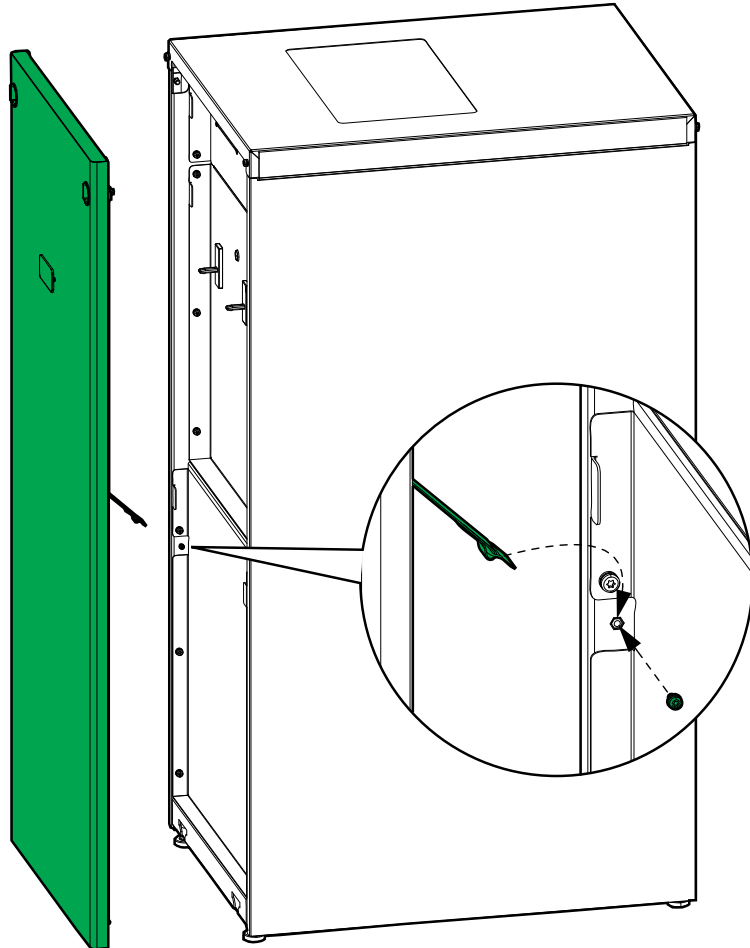

4. Follow the UPS installation manual to connect the power cables from the maintenance bypass cabinet in the UPS and to complete the rest of the UPS installation.

Schneider Electric
35 rue Joseph Monier
92500 Rueil Malmaison
France

+ 33 (0) 1 41 29 70 00



As standards, specifications, and design change from time to time,
please ask for confirmation of the information given in this publication.

© 2018 – 2020 Schneider Electric. All rights reserved.

990-91138A-001