

Light Curtain Quick Start Guide

This guide will show you how to troubleshoot light curtains connected to NX-Safety I/O.

Troubleshooting

- 1.) Is it PNP?
- 2.) Is it aligned?
- 3.) Is wiring correct?
- 4.) Continuity?
- 5.) Power supply separate from servo brakes?
- 6.) 24V and 0V coming from the same power supply?

PNP and NPN

Safety applications require a PNP light curtain. PNP means there will be no voltage to the load if the output line has a ground fault.

NPN is not used for safety since the equipment can run out of control if the wires touch the equipment frame. It would act like a switch.

In the America's market only PNP are sold. NPN light curtains may come into the America's through Japanese automotive specifications.

How to check:

The receiver (unit with the black cable) has the part number. If the end of the part number has a P, it is PNP. (Note: N would be NPN)



Sample PNP part number: F3SJ-B0225 **P**25-D

Alignment

Blue lights at the ends of both light curtains should be on. If not, loosen bracket, readjust, and tighten.



Broken Beam(s)

Easy way to see if a beam has been broken by the environment is to look for red indicator lights being on.

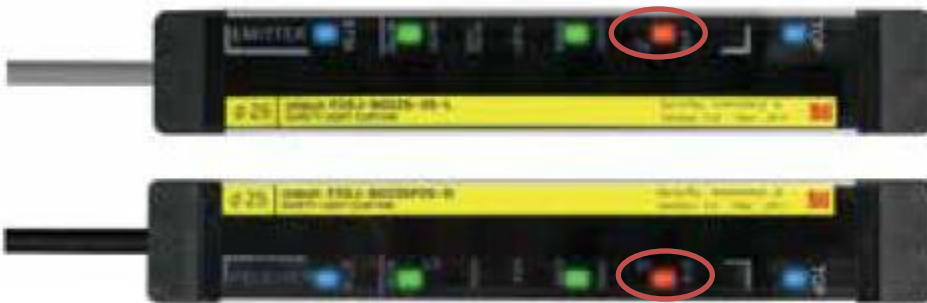

Continuity

Use a voltmeter to check the continuity between the wire on the light curtain to the input wire connected to the NX-Safety I/O.

Also check the continuity between the 24 V on the power supply to the input wire connected to the NX.

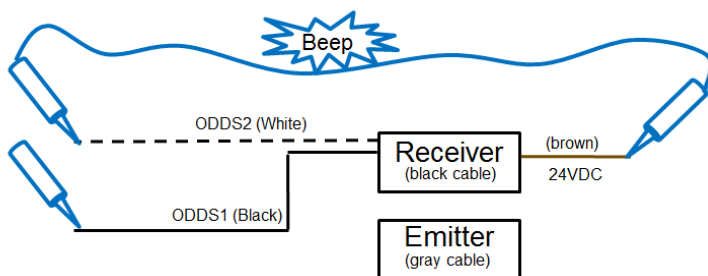

Wiring

These application examples are from G9SP manuals.

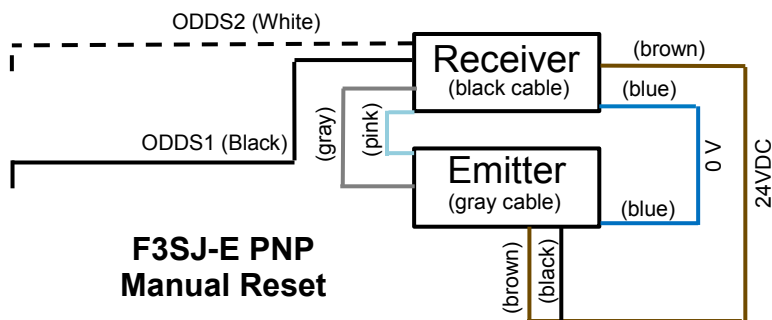
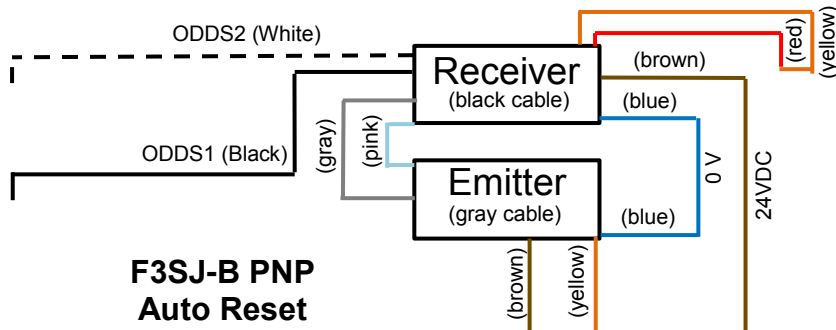

Note: The PNP is wired the opposite of NPN. So all of the 24V on a PNP are 0 V on NPN, and vice versa.

Power Supply

Make sure 24V and 0V are coming from the same power supply. If they are separated, the output will only turn on when the light curtain is blocked Opposite of what it should do!

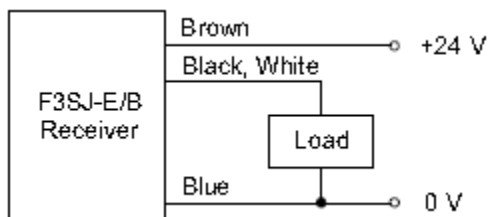

Best practice:

Servo brake and I/O should be on separate power supplies. Sharing can cause noise on the I/O lines when the brake is applied.

Is also good practice to have separate power supplies for the coupler and the I/O devices.

Parameter / Node

Select Semiconductor output for dual channel equivalent.

Multiview explorer -> Select Safety CPU -> Configuration and setup -> Communications -> Safety -> Safety I/O -> Select a node -> double click on parameters -> click on the white X next to the filter to see all of the nodes -> use **toolbox** to select a safety device (might need to drag right side window to see the toolbox) -> drag and drop parameter to knob -> complete for all nodes. **Note: The fields in the nodes are not used in the program. Could be used to enter part name/type/number.**

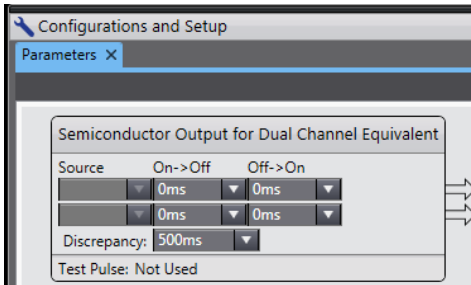

I/O Map

Setup variables in the I/O map.

Multiview Explorer -> select Safety CPU -> Configurations and Setup -> double click on I/O Map -> make sure arrow buttons are all pointing down -> use variable template to paste (**Note: It will not paste if there is an empty field. Can only do groups when no empty fields.**) **OR** manually enter with right click **OR** scroll down to highlight all variables -> right click -> select variable. (**Note: Do not enter a variable name for the second input or output of dual channel devices.**)

Pos Nc	Port	R/W	Data Type	Variable
	▼ NX-SID80			
	▼ Safety Inputs			
	Si00 Logical Value	R	SAFEBOOL	G5In
	Si01 Logical Value	R	SAFEBOOL	
	Si02 Logical Value	R	SAFEBOOL	Light_curtain_1
	Si03 Logical Value	R	SAFEBOOL	
	Si04 Logical Value	R	SAFEBOOL	Light_curtain_2
	Si05 Logical Value	R	SAFEBOOL	
	Si06 Logical Value	R	SAFEBOOL	Estop
	Si07 Logical Value	R	SAFEBOOL	

Program

Use ESPE Safety function block, with output to and EDM Safety function block. (In this example, it is using G5 servo drive with direct connect to safety. Normally would be force guided contacts.)

Multiview Explorer -> select new_safetyCPU -> Programming -> POU -> Programs -> Program0

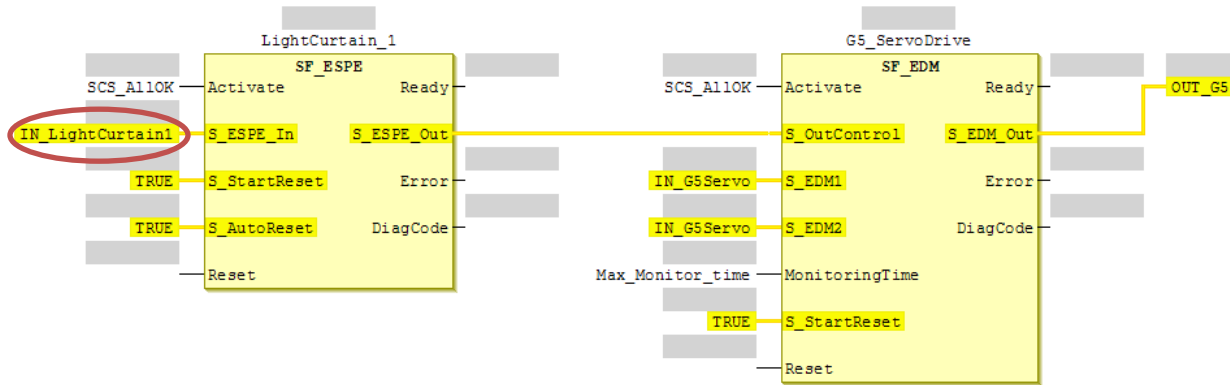

What to see at startup

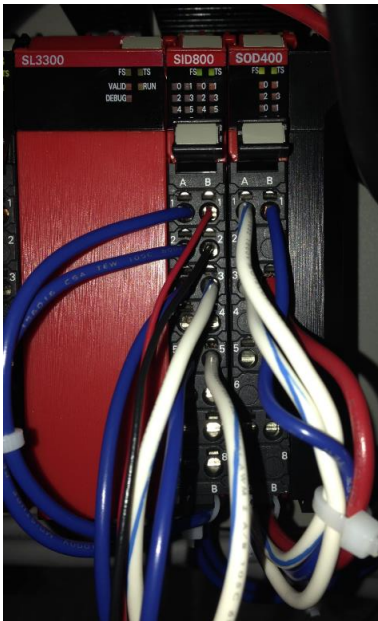

Image of NX CPU, SID800 input, SOH400 output.

The yellow indicator lights will be on when they are operational.

The FS and TS lights at the top will be green.

