



Changes for the Better

Mitsubishi Electric Magnetic Starters Old/New Model Comparison Material

New MS-T/MS-N Series

MS-T Series

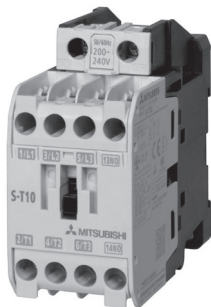

AC Operated Magnetic Contactors
S-T10

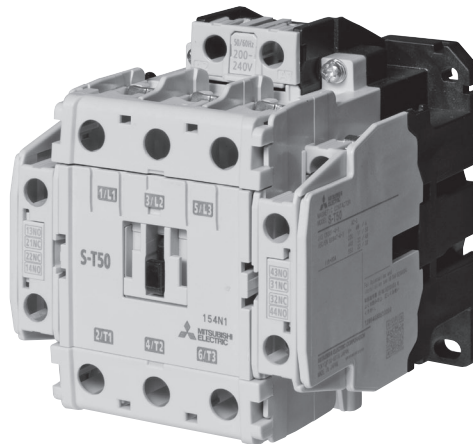

AC Operated Magnetic Contactors
S-T50

Table of Contents

	Page
1. Comparison of New and Old Specifications	
1.1 Magnetic Starters (Enclosed Type)	1
1.2 Magnetic Starters (Open Type)	3
1.3 Magnetic Contactors	7
1.4 Thermal Overload Relays	13
1.5 Contactor Relays	14
2. New and Old Model Name Comparison Table	
2.1 Magnetic Starters (Enclosed Type)	16
2.2 Magnetic Starters (Open Type)	16
2.3 Magnetic Contactors (Open Type)	17
2.4 Thermal Overload Relays	20
2.5 Contactor Relays	20
3. Comparison of New and Old Coil Rating	
3.1 Control Coil Types and Rating [AC Operation]	21
3.2 Control Coil Types and Rating [DC Operation]	22
3.3 Control Coil Types and Rating [Mechanically Latched Type]	22
4. Changes to Product Marking	
4.1 Terminal Number Display	23
4.2 Rating Display	25
4.3 Model Name Display	25
5. Differences Related to Wiring/Handling	
5.1 Terminals/Location	26
5.2 Rail Mounting	27
6. Application of Thermal Overload Relays and Optional Units	
6.1 Combining with Thermal Overload Relays and Optional Units	28
6.2 Optional Units for Thermal Overload Relays	30
6.3 Compatibility of New and Old Thermal Overload Relays and Magnetic Contactors When Used In Combination	30
7. Domestic and International Standards	
7.1 Regulations/Standards Conformance	31
7.2 Comparison of UL Certified SCCR (Short-Circuit Current Rating)	31
8. Comparison of Other Specifications	
8.1 Maintenance and Inspection	32
9. Comparison of External Dimensions/Mounting Dimensions	
9.1 Enclosed Type Magnetic Starters (Non-Reversing)	33
9.2 Open Type Magnetic Starters (Non-Reversing)	36
9.3 Magnetic Contactors (Non-Reversing)	43
9.4 Enclosed Type Magnetic Starters (Reversing)	51
9.5 Open Type Magnetic Starters (Reversing)	54
9.6 Magnetic Contactors (Reversing)	60
9.7 Thermal Overload Relays	66
9.8 Contactor Relays	68
10. New and Old Model Comparison Table for Magnetic Starters/Magnetic Contactors/Contactor Relays	
10.1 Magnetic Starters (Enclosed Type)	71
10.2 Magnetic Starters (Open Type)	72
10.3 Magnetic Contactors	73
10.4 Contactor Relays	75

[Table of Models] (New MS-T Series are models shown in)

Standard															Main Circuit 3-Pole					
Class AC-3/200V Rated Operating Current (A)				11	13	18	20	26	35	50	65	80	100	125 - 400	630	800	32	35	50	
AC Operated	Magnetic Contactors	Non-Reversing	S-	T10	T12	T20	T21	T25	T35	T50	T65	T80	T100	N125 - N400	N600	N800	T32	N38	N48	
		Reversing	S-2x	T10	T12	T20	T21	T25	T35	T50	T65	T80	T100	N125 - N400	N600	N800	T32	N38	N48	
	Magnetic Starters	Non-Reversing	MSO-	T10	T12	T20	T21	T25	T35	T50	T65	T80	T100	N125 - N400	-	-	-	-	-	
		Reversing	MSO-2x	T10	T12	T20	T21	T25	T35	T50	T65	T80	T100	N125 - N400	-	-	-	-	-	
DC Operated	Magnetic Contactors	Non-Reversing	SD-	-	T12	T20	T21	-	T35	T50	T65	T80	T100	N125 - N400	N600	N800	T32	-	-	
		Reversing	SD-2x	-	T12	T20	T21	-	T35	T50	T65	T80	T100	N125 - N400	N600	N800	T32	-	-	
	Magnetic Starters	Non-Reversing	MSOD-	-	T12	T20	T21	-	T35	T50	T65	T80	T100	N125 - N400	-	-	-	-	-	
		Reversing	MSOD-2x	-	T12	T20	T21	-	T35	T50	T65	T80	T100	N125 - N400	-	-	-	-	-	
Mechanically Latched Type	AC Operated	Magnetic Contactors	Non-Reversing	SL-	-	-	-	T21	-	T35	T50	T65	T80	T100	N125 - N400	N600	N800	-	-	-
			Reversing	SL-2x	-	-	-	T21	-	T35	T50	T65	T80	T100	N125 - N400	N600	N800	-	-	-
	DC Operated	Magnetic Contactors	Non-Reversing	SLD-	-	-	-	T21	-	T35	T50	T65	T80	T100	N125 - N400	N600	N800	-	-	-
			Reversing	SLD-2x	-	-	-	T21	-	T35	T50	T65	T80	T100	N125 - N400	N600	N800	-	-	-

Number of Contacts (Total Number of Make/Break Contacts)		5	9	10	
Contactor Relays	AC Operated	SR-	T5	T9	K100
	DC Operated	SRD-	T5	T9	K100
	Mechanically Latched (AC Operated)	SRL-	T5	-	K100
	Mechanically Latched (AC Operated)	SRLD-	T5	-	K100

Maximum Setting Current (A)		18	26	50	65	100	120 - 800
Thermal Overload Relays	Standard with 2-Element TH-	T18	T25	T50	T65	T100	N120 - N600
	With Open-Phase Protection TH-	T18KP	T25KP	T50KP	T65KP	T100KP	N120KP - N600KP

1. Comparison of New and Old Specifications

1.1 Magnetic Starters (Enclosed Type)

Model Name		Item	New MS-T Series Support for Structure/Rating
Existing (S-N Series) [Number of Auxiliary Contacts]	New (S-T Series) [Number of Auxiliary Contacts]		
MS-N10 [1]	MS-T10 [1]	Rating (Main Circuit)	Equivalent
		Rating (Auxiliary Circuit)	Identical
		Rating (Coil)	Expanded Rating Range
		External Dimensions [H x W x D] (mm)	Identical (165 x 76 x 97.5 ⇒ 165 x 76 x 97.5)
		Mounting Dimension (Recommended mounting hole pitch)	Compatible
		Contact Arrangement	Identical
		Terminal Cover	Without Terminal Cover (Product Identical to S-N Series with IP20 Protection Degree)
		Terminal Screw Size	Identical (M3.5)
		Applicable Wire Size [ϕ mm, mm ²] (Bare Wire)	Equivalent
Applicable Crimp Lug Size	Identical		
MS-N11 [1]	MS-T12 [2]	Rating (Main Circuit)	Equivalent
		Rating (Auxiliary Circuit)	Identical
		Rating (Coil)	Expanded Rating Range
		External Dimensions [H x W x D] (mm)	Identical (165 x 76 x 97.5 ⇒ 165 x 76 x 97.5)
		Mounting Dimension (Recommended mounting hole pitch)	Compatible
		Contact Arrangement	Increased Auxiliary Contacts (1-Pole ⇒ 2-Pole)
		Terminal Cover	Without Terminal Cover (Product Identical to S-N Series with IP20 Protection Degree)
		Terminal Screw Size	Identical (M3.5)
		Applicable Wire Size [ϕ mm, mm ²] (Bare Wire)	Equivalent
Applicable Crimp Lug Size	Identical		
MS-N12 [2]	MS-T12 [2]	Rating (Main Circuit)	Equivalent
		Rating (Auxiliary Circuit)	Identical
		Rating (Coil)	Expanded Rating Range
		External Dimensions [H x W x D] (mm)	Identical (165 x 76 x 97.5 ⇒ 165 x 76 x 97.5)
		Mounting Dimension (Recommended mounting hole pitch)	Compatible
		Contact Arrangement	Identical
		Terminal Cover	Without Terminal Cover (Product Identical to S-N Series with IP20 Protection Degree)
		Terminal Screw Size	Identical (M3.5)
		Applicable Wire Size [ϕ mm, mm ²] (Bare Wire)	Equivalent
Applicable Crimp Lug Size	Identical		
MS-N20 [2]	MS-T21 [4]	Rating (Main Circuit)	Equivalent
		Rating (Auxiliary Circuit)	Identical
		Rating (Coil)	Expanded Rating Range
		External Dimensions [H x W x D] (mm)	Identical (176 x 104 x 110 ⇒ 176 x 104 x 110)
		Mounting Dimension (Recommended mounting hole pitch)	Compatible
		Contact Arrangement	Increased Auxiliary Contacts (2-Pole ⇒ 4-Pole)
		Terminal Cover	Without Terminal Cover (Product Identical to S-N Series with IP20 Protection Degree)
		Terminal Screw Size	Identical (Main: M4, Coil/Auxiliary: M3.5)
		Applicable Wire Size [ϕ mm, mm ²] (Bare Wire)	Equivalent
Applicable Crimp Lug Size	Identical		
MS-N21 [4]	MS-T21 [4]	Rating (Main Circuit)	Equivalent
		Rating (Auxiliary Circuit)	Identical
		Rating (Coil)	Expanded Rating Range
		External Dimensions [H x W x D] (mm)	Identical (176 x 104 x 110 ⇒ 176 x 104 x 110)
		Mounting Dimension (Recommended mounting hole pitch)	Compatible
		Contact Arrangement	Identical
		Terminal Cover	Without Terminal Cover (Product Identical to S-N Series with IP20 Protection Degree)
		Terminal Screw Size	Identical (Main: M4, Coil/Auxiliary: M3.5)
		Applicable Wire Size [ϕ mm, mm ²] (Bare Wire)	Equivalent
Applicable Crimp Lug Size	Identical		

[AC Operated Type]

Model Name		Item	New MS-T Series Support for Structure/Rating
Existing (S-N Series) [Number of Auxiliary Contacts]	New (S-T Series) [Number of Auxiliary Contacts]		
MS-N35 [4]	MS-T35 [4]	Rating (Main Circuit)	Identical
		Rating (Auxiliary Circuit)	Identical
		Rating (Coil)	Expanded Rating Range
		External Dimensions [H x W x D] (mm)	Identical (231 x 135 x 126 ⇒ 231 x 135 x 126)
		Mounting Dimension (Recommended mounting hole pitch)	Compatible
		Contact Arrangement	Identical
		Terminal Cover	Without Terminal Cover (Product Identical to S-N Series with IP20 Protection Degree)
		Terminal Screw Size	Identical
		Applicable Wire Size [φ mm, mm ²] (Bare Wire)	Different Main: 2 - 5.5 (At Load Side with Heater Designation 15A or Less) ⇒ Power Source Side 1.25 - 16 Load Side 1.25 - 14 Coil/Auxiliary: φ 1.6, 1.25 - 2 ⇒ φ 1.6, 0.75 - 2.5
		Applicable Crimp Lug Size	Identical
MS-N50 [4]	MS-T50 [4]	Rating (Main Circuit)	Identical
		Rating (Auxiliary Circuit)	Identical
		Rating (Coil)	Different in Part (300 VAC--260 - 350 VAC ⇒ 260 - 300 VAC), Identical Range for Others
		External Dimensions [H x W x D] (mm)	Smaller (282 x 160 x 145 ⇒ 231 x 135 x 126)
		Mounting Dimension (Recommended mounting hole pitch)	Not Compatible (MS-T65 for Mounting Compatibility)
		Contact Arrangement	Identical
		Terminal Cover	Without Terminal Cover (Product Identical to S-N Series with IP20 Protection Degree)
		Terminal Screw Size	Different (- 22A Designation -- Main: M6, Coil/Auxiliary: M4 ⇒ Main (Power Supply Side/Load Side): M5/M4, Coil/Auxiliary: M3.5) (29A Designation - -- Main: M6, Coil/Auxiliary: M4 ⇒ Main (Power Supply Side/Load Side): M5/M5, Coil/Auxiliary: M3.5)
		Applicable Wire Size [φ mm, mm ²] (Bare Wire)	Different Main : - ⇒ Power Supply Side 1.25 - 16 Load Side 1.25 - 14 Coil/Auxiliary : φ 1.6, 1.25 - 2 ⇒ φ 1.6, 0.75 - 2.5
		Applicable Crimp Lug Size	Different (Main) (- 22A Designation -- 1.25-6 - 22-6 ⇒ (Power Supply Side/Load Side)1.25-5 - 22-5/1.25-4 - 5.5-4) (29A Designation - -1.25-6 - 22-6 ⇒ 1.25-5 - 22-5) Different (Auxiliary/Coil) [1.25-4 - 2-4 ⇒ 1.25-3.5 - 2-3.5]
MS-N65 [4]	MS-T65 [4]	Rating (Main Circuit)	Identical
		Rating (Auxiliary Circuit)	Identical
		Rating (Coil)	Identical
		External Dimensions [H x W x D] (mm)	Identical
		Mounting Dimension (Recommended mounting hole pitch)	Compatible
		Contact Arrangement	Identical
		Terminal Cover	Without Terminal Cover (Product Identical to S-N Series with IP20 Protection Degree)
		Terminal Screw Size	Identical
		Applicable Crimp Lug Size	Identical
		MS-N80 [4]	MS-T80 [4]
Rating (Auxiliary Circuit)	Identical		
Rating (Coil)	Identical		
External Dimensions [H x W x D] (mm)	Smaller (317 x 190 x 163 ⇒ 282 x 160 x 145)		
Mounting Dimension (Recommended mounting hole pitch)	Not Compatible (MS-T100 for Mounting Compatibility)		
Contact Arrangement	Identical		
Terminal Cover	Without Terminal Cover (Product Identical to S-N Series with IP20 Protection Degree)		
Terminal Screw Size	Identical		
Applicable Crimp Lug Size	Different (Main) [(Power Supply Side/Load Side) 1.25-6 - 60-6/14-6 - 22-6, 38-S6 ⇒ 60-S6/14-6 - 22-6, 38-S6] Identical (Auxiliary/Coil)		
MS-N95 [4]	MS-T100 [4]		
		Rating (Auxiliary Circuit)	Identical
		Rating (Coil)	Identical
		External Dimensions [H x W x D] (mm)	Identical
		Mounting Dimension (Recommended mounting hole pitch)	Identical
		Contact Arrangement	Identical
		Terminal Cover	Without Terminal Cover (Product Identical to S-N Series with IP20 Protection Degree)
		Terminal Screw Size	Identical
		Applicable Crimp Lug Size	Identical

1.2 Magnetic Starters (Open Type)

[AC Operated Type]

Model Name		Item	New MSO-T Series Support for Structure/Rating
Existing (S-N Series) (Number of Auxiliary Contacts)	New (S-T Series) (Number of Auxiliary Contacts)		
MSO-N10 [1]	MSO-T10 [1]	Rating (Main Circuit)	Equivalent
		Rating (Auxiliary Circuit)	Identical
		Rating (Coil)	Expanded Rating Range
		External Dimensions [H x W x D] (mm)	Equivalent (115 x 45 x 79 ⇒ 115 x 46 x 79)
		Mounting Dimension (Recommended mounting hole pitch)	Not Compatible (Compatible with Adapter)
		Contact Arrangement	Identical
		Terminal Cover	Changed to Standard Equipment
		Terminal Screw Size	Identical (M3.5)
		Applicable Wire Size [φ mm, mm ²] (Bare Wire)	Equivalent
		Applicable Crimp Lug Size	Identical
MSO-N11 [1]	MSO-T12 [2]	Rating (Main Circuit)	Equivalent
		Rating (Auxiliary Circuit)	Identical
		Rating (Coil)	Expanded Rating Range
		External Dimensions [H x W x D] (mm)	Equivalent (115 x 45 x 79 ⇒ 115 x 46 x 79)
		Mounting Dimension (Recommended mounting hole pitch)	Compatible
		Contact Arrangement	Increased Auxiliary Contacts (1-Pole ⇒ 2-Pole)
		Terminal Cover	Changed to Standard Equipment
		Terminal Screw Size	Identical (M3.5)
		Applicable Wire Size [φ mm, mm ²] (Bare Wire)	Equivalent
		Applicable Crimp Lug Size	Identical
MSO-N12 [2]	MSO-T12 [2]	Rating (Main Circuit)	Equivalent
		Rating (Auxiliary Circuit)	Identical
		Rating (Coil)	Expanded Rating Range
		External Dimensions [H x W x D] (mm)	Smaller (115 x 55 x 79 ⇒ 115 x 46 x 79)
		Mounting Dimension (Recommended mounting hole pitch)	Not Compatible (Compatible with Adapter)
		Contact Arrangement	Identical
		Terminal Cover	Changed to Standard Equipment
		Terminal Screw Size	Identical (M3.5)
		Applicable Wire Size [φ mm, mm ²] (Bare Wire)	Equivalent
		Applicable Crimp Lug Size	Identical
MSO-N18 [0]	MSO-T20 [2]	Rating (Main Circuit)	Equivalent
		Rating (Coil)	Expanded Rating Range
		External Dimensions [H x W x D] (mm)	Smaller (122 x 54 x 81 ⇒ 115 x 46 x 79)
		Mounting Dimension (Recommended mounting hole pitch)	Compatible
		Contact Arrangement	Increased Auxiliary Contacts (0-Pole ⇒ 2-Pole)
		Terminal Cover	Changed to Standard Equipment
		Terminal Screw Size	Different (Main: M4, Coil/Auxiliary: M3.5 ⇒ Main: M3.5, Coil/Auxiliary: M3.5)
		Applicable Wire Size [φ mm, mm ²] (Bare Wire)	Different (Main: φ 1.6 - φ 2.6, 2 - 5.5 Coil/Auxiliary: φ 1.6, 1.25 - 2 ⇒ Main: φ 1.6, 0.75 - 2.5 Coil/Auxiliary: φ 1.6, 0.75 - 2.5)
		Applicable Crimp Lug Size	Different (Main: 1.25-4 - 5.5-4, Coil/Auxiliary: 1.25-3.5 - 2-3.5 ⇒ Main: 1.25-3.5 - 2-3.5 5.5-S3, Coil/Auxiliary: 1.25-3.5 - 2-3.5)
		MSO-N20 [2]	MSO-T21 [4]
Rating (Auxiliary Circuit)	Identical		
Rating (Coil)	Expanded Rating Range		
External Dimensions [H x W x D] (mm)	Smaller (127 x 63 x 81 ⇒ 115 x 46 x 79)		
Mounting Dimension (Recommended mounting hole pitch)	Not Compatible (Compatible with Adapter)		
Contact Arrangement	Identical		
Terminal Cover	Changed to Standard Equipment		
Terminal Screw Size	Different (Main: M4, Coil/Auxiliary: M3.5 ⇒ Main: M3.5, Coil/Auxiliary: M3.5)		
Applicable Wire Size [φ mm, mm ²] (Bare Wire)	Different (Main: φ 1.6 - φ 2.6, 2 - 5.5 Coil/Auxiliary: φ 1.6, 1.25 - 2 ⇒ Main: φ 1.6, 0.75 - 2.5 Coil/Auxiliary: φ 1.6, 0.75 - 2.5)		
Applicable Crimp Lug Size	Different (Main: 1.25-4 - 5.5-4, Coil/Auxiliary: 1.25-3.5 - 2-3.5 ⇒ Main: 1.25-3.5 - 2-3.5 5.5-S3, Coil/Auxiliary: 1.25-3.5 - 2-3.5)		
MSO-N21 [4]	MSO-T21 [4]	Rating (Main Circuit)	Equivalent
		Rating (Auxiliary Circuit)	Identical
		Rating (Coil)	Expanded Rating Range
		External Dimensions [H x W x D] (mm)	Equivalent (127 x 63 x 81 ⇒ 128 x 63 x 82)
		Mounting Dimension (Recommended mounting hole pitch)	Compatible
		Contact Arrangement	Identical
		Terminal Cover	Changed to Standard Equipment
		Terminal Screw Size	Identical (Main: M4, Coil/Auxiliary: M3.5)
		Applicable Wire Size [φ mm, mm ²] (Bare Wire)	Equivalent
		Applicable Crimp Lug Size	Identical
MSO-N21 [4]	MSO-T25 [4]	Rating (Main Circuit)	Equivalent or Higher (MSO-N25 Equivalent)
		Rating (Auxiliary Circuit)	Identical
		Rating (Coil)	Expanded Rating Range
		External Dimensions [H x W x D] (mm)	Equivalent (127 x 63 x 81 ⇒ 128 x 63 x 82)
		Mounting Dimension (Recommended mounting hole pitch)	Compatible
		Contact Arrangement	Identical
		Terminal Cover	Changed to Standard Equipment
		Terminal Screw Size	Identical (Main: M4, Coil/Auxiliary: M3.5)
		Applicable Wire Size [φ mm, mm ²] (Bare Wire)	Equivalent
		Applicable Crimp Lug Size	Identical

[AC Operated Type]

Model Name		Item	New MSO-T Series Support for Structure/Rating
Existing (S-N Series) (Number of Auxiliary Contacts)	New (S-T Series) (Number of Auxiliary Contacts)		
MSO-N25 [4]	MSO-T25 [4]	Rating (Main Circuit)	Equivalent
		Rating (Auxiliary Circuit)	Identical
		Rating (Coil)	Expanded Rating Range
		External Dimensions [H x W x D] (mm)	Smaller (136.5 (- 15A Designation), 157.5 (22A Designation) x 75 x 91 ⇒ 128 x 63 x 82)
		Mounting Dimension (Recommended mounting hole pitch)	Not Compatible (Compatible with Adapter)
		Contact Arrangement	Identical
		Terminal Cover	Changed to Standard Equipment
		Applicable Wire Size [φ mm, mm ²] (Bare Wire)	Different Main: 2 - 5.5 (At Load Side with Heater Designation 15A or Less) ⇒ Power Source Side 1.25 - 16 Load Side 1.25 - 14 Coil/Auxiliary: φ 1.6, 1.25 - 2 ⇒ φ 1.6, 0.75 - 2.5
		Terminal Screw Size	Different (Coil/Auxiliary Identical) (- 15A Designation -- Main (Power Supply Side/Load Side): M5/M4, Coil/Auxiliary: M3.5 ⇒ Main: M4, Coil/Auxiliary: M3.5) (22A Designation -- Main(Power Supply Side/Load Side): M5/M5, Coil/Auxiliary: M3.5 ⇒ Main: M4, Coil/Auxiliary: M3.5)
		Applicable Crimp Lug Size	Different (Coil/Auxiliary Identical) (- 15A Designation -- Main (Power Supply Side/Load Side): 1.25-5 - 14-5/2-4 - 5.5-4 ⇒ 1.25-4 - 5.5-4/1.25-4 - 5.5-4) (22A Designation -- Main (Power Supply Side/Load Side): 1.25-5 - 14-5/5.5-5 - 14-5 ⇒ 1.25-4 - 5.5-4/1.25-4 - 5.5-4)
MSO-N35 [4]	MSO-T35 [4]	Rating (Main Circuit)	Identical
		Rating (Auxiliary Circuit)	Identical
		Rating (Coil)	Expanded Rating Range
		Coil Properties (Operating Time)	Equivalent
		Coil Properties (Input)	Equivalent
		Coil Surge Absorber Function	Identical (Optional Support)
		External Dimensions [H x W x D] (mm)	Identical
		Mounting Dimension (Recommended mounting hole pitch)	Compatible
		Contact Arrangement	Identical
		Terminal Cover	Changed to Standard Equipment
Terminal Screw Size	Identical		
Applicable Wire Size [φ mm, mm ²] (Bare Wire)	Different Main: 2 - 5.5 (At Load Side with Heater Designation 15A or Less) ⇒ Power Source Side 1.25 - 16 Load Side 1.25 - 14 Coil/Auxiliary: φ 1.6, 1.25 - 2 ⇒ φ 1.6, 0.75 - 2.5		
Applicable Crimp Lug Size	Identical		
MSO-N50 [4]	MSO-T50 [4]	Rating (Main Circuit)	Identical
		Rating (Auxiliary Circuit)	Identical
		Rating (Coil)	Different in Part (300 VAC--260 - 350 VAC ⇒ 260 - 300 VAC), Identical Range for Others
		Coil Properties (Operating Time)	ON Operation: 20 - 30 ms ⇒ 10 - 20 ms, OFF Operation: 35 - 65 ms ⇒ 5 - 14 ms
		Coil Properties (Input)	Different (2.2W ⇒ 3.8W)
		Coil Surge Absorber Function	Different (Standard Type ⇒ Optional Support)
		External Dimensions [H x W x D] (mm)	Smaller (158 x 90 x 106 ⇒ 136.5 (- 22A Designation), 157.5 (29A Designation -) x 75 x 91)
		Mounting Dimension (Recommended mounting hole pitch)	Not Compatible (Compatible with Adapter)
		Contact Arrangement	Identical
		Terminal Cover	Changed to Standard Equipment
Terminal Screw Size	Different (- 22A Designation -- Main: M6, Coil/Auxiliary: M4 ⇒ Main (Power Supply Side/Load Side): M5/M4, Coil/Auxiliary: M3.5) (29A Designation - -- Main: M6, Coil/Auxiliary: M4 ⇒ Main (Power Supply Side/Load Side): M5/M5, Coil/Auxiliary: M3.5)		
Applicable Wire Size [φ mm, mm ²] (Bare Wire)	Different Main : - ⇒ Power Supply Side 1.25 - 16 Load Side 1.25 - 14 Coil/Auxiliary: φ 1.6, 1.25 - 2 ⇒ φ 1.6, 0.75 - 2.5		
Applicable Crimp Lug Size	Different (Main) (- 22A Designation -- 1.25-6 - 22-6 ⇒ (Power Supply Side/Load Side)1.25-5 - 22-5/1.25-4 - 5.5-4) (29A Designation - -1.25-6 - 22-6 ⇒ 1.25-5 - 22-5) Different (Auxiliary/Coil) [1.25-4 - 2-4 ⇒ 1.25-3.5 - 2-3.5]		
MSO-N65 [4]	MSO-T65 [4]	Rating (Main Circuit)	Identical
		Rating (Auxiliary Circuit)	Identical
		Rating (Coil)	Identical Range
		Coil Properties (Operating Time)	Identical
		Coil Properties (Input)	Identical
		Coil Surge Absorber Function	Equivalent (Standard Equipment)
		External Dimensions [H x W x D] (mm)	Identical
		Mounting Dimension (Recommended mounting hole pitch)	Identical
		Contact Arrangement	Identical
		Terminal Cover	Equivalent (Special Product or Optional Support)
Terminal Screw Size	Identical		
Applicable Crimp Lug Size	Identical		
MSO-N80 [4]	MSO-T80 [4]	Rating (Main Circuit)	Equivalent
		Rating (Auxiliary Circuit)	Identical
		Rating (Coil)	Identical Range
		Coil Properties (Operating Time)	ON Operation: Equivalent, OFF Operation: 50 - 100 ms ⇒ 35 - 65 ms
		Coil Properties (Input)	Low Input (2.8W ⇒ 2.2W)
		Coil Surge Absorber Function	Equivalent (Standard Equipment)
		External Dimensions [H x W x D] (mm)	Smaller (179.5 (- 54A Designation), 196 (67A Designation) x 100 x 127 ⇒ 158 (- 54A Designation), 169.5 (67A Designation) x 90 x 106)
		Mounting Dimension (Recommended mounting hole pitch)	Not Compatible (Compatible with Adapter)
		Contact Arrangement	Identical
		Terminal Cover	Equivalent (Special Product or Optional Support)
Terminal Screw Size	Identical		
Applicable Crimp Lug Size	Different (Main) [(Power Supply Side/Load Side) 1.25-6 - 60-6/14-6 - 22-6, 38-S6 ⇒ 60-S6/14-6 - 22-6, 38-S6] Identical (Auxiliary/Coil)		
MSO-N95 [4]	MSO-T100 [4]	Rating (Main Circuit)	Identical
		Rating (Auxiliary Circuit)	Identical
		Rating (Coil)	Identical Range
		Coil Properties (Operating Time)	Identical
		Coil Properties (Input)	Identical
		Coil Surge Absorber Function	Equivalent (Standard Equipment)
		External Dimensions [H x W x D] (mm)	Equivalent (196 x 100 x 127 ⇒ 191 x 100 x 127)
		Mounting Dimension (Recommended mounting hole pitch)	Identical
		Contact Arrangement	Identical
		Terminal Cover	Identical (Optional Support)
Terminal Screw Size	Identical		
Applicable Crimp Lug Size	Identical		

[DC Operated Type]

Model Name		Item	New MSOD-T Series Support for Structure/Rating	
Existing (S-N Series) [Number of Auxiliary Contacts]	New (S-T Series) [Number of Auxiliary Contacts]			
MSOD-N11 [1]	MSOD-T12 [2]	Rating (Main Circuit)	Equivalent	
		Rating (Auxiliary Circuit)	Identical	
		Rating (Coil)	Identical Range	
		Coil (Operating Time)	ON Operation: 45 ms ⇒ 85 ms (24 VDC or Less), 60 ms (48 VDC or More) OFF Operation: 13 ms ⇒ 10 ms	
		Coil (Input)	Low Input (7W ⇒ 24 VDC or Less: 2.2W, 48 VDC or More: 3.3W)	
		Coil (Polarity)	N/A ⇒ Available	
		External Dimensions [H x W x D] (mm)	Equivalent (116 x 45 x 111 ⇒ 115 x 46 x 101)	
		Mounting Dimension (Recommended mounting hole pitch)	Compatible	
		Contact Arrangement	Increased Auxiliary Contacts (1-Pole ⇒ 2-Pole)	
		Terminal Cover	Changed to Standard Equipment	
		Terminal Screw Size	Identical (M3.5)	
MSOD-N12 [2]	MSOD-T12 [2]	Applicable Wire Size [φ mm, mm ²] (Bare Wire)	Equivalent	
		Applicable Crimp Lug Size	Identical	
		Rating (Main Circuit)	Equivalent	
		Rating (Auxiliary Circuit)	Identical	
		Rating (Coil)	Identical Range	
		Coil Properties (Operating Time)	ON Operation: 45 ms ⇒ 85 ms (24 VDC or Less), 60 ms (48 VDC or More) OFF Operation: 13 ms ⇒ 10 ms	
		Coil Properties (Input)	Low Input (7W ⇒ 24 VDC or Less: 2.2W, 48 VDC or More: 3.3W)	
		Coil (Polarity)	N/A ⇒ Available	
		External Dimensions [H x W x D] (mm)	Smaller (116 x 55 x 111 ⇒ 115 x 46 x 101)	
		Mounting Dimension (Recommended mounting hole pitch)	Not Compatible (Compatible with Adapter)	
		Contact Arrangement	Identical	
Terminal Cover	Changed to Standard Equipment			
Terminal Screw Size	Identical (M3.5)			
Applicable Wire Size [φ mm, mm ²] (Bare Wire)	Equivalent			
Applicable Crimp Lug Size	Identical			
MSOD-N21 [4]	MSOD-T20 [2]	Rating (Main Circuit)	Equivalent	
		Rating (Auxiliary Circuit)	Identical	
		Rating (Coil)	Identical Range	
		Coil Properties (Operating Time)	ON Operation: 50 ms ⇒ 85 ms (24 VDC or Less), 60 ms (48 VDC or More) OFF Operation: 8 ms ⇒ 10 ms	
		Coil Properties (Input)	Low Input (9W ⇒ 24 VDC or Less: 2.2W, 48 VDC or More: 3.3W)	
		Coil (Polarity)	N/A ⇒ Available	
		External Dimensions [H x W x D] (mm)	Smaller (127 x 63 x 113 ⇒ 115 x 46 x 101)	
		Mounting Dimension (Recommended mounting hole pitch)	Not Compatible (Compatible with Adapter)	
		Contact Arrangement	Reduced Auxiliary Contacts (4-Pole ⇒ 2-Pole)	
		Terminal Cover	Changed to Standard Equipment	
		Terminal Screw Size	Different (Main: M4, Coil/Auxiliary: M3.5 ⇒ Main: M3.5, Coil/Auxiliary: M3.5)	
	Applicable Wire Size [φ mm, mm ²] (Bare Wire)	Different (Main: φ 1.6 - φ 2.6, 2 - 5.5 Coil/Auxiliary: φ 1.6, 1.25 - 2 ⇒ Main: φ 1.6, 0.75 - 2.5 Coil/Auxiliary: φ 1.6, 0.75 - 2.5)		
	Applicable Crimp Lug Size	Different (Main: 1.25-4 - 5.5-4, Coil/Auxiliary: 1.25-3.5 - 2-3.5 ⇒ Main: 1.25-3.5 - 2-3.5 5.5-S3, Coil/Auxiliary: 1.25-3.5 - 2-3.5)		
	MSOD-T21 [4]	MSOD-T21 [4]	Rating (Main Circuit)	Equivalent
			Rating (Auxiliary Circuit)	Identical
			Rating (Coil)	Identical Range
			Coil Properties (Operating Time)	ON Operation: 50 ms ⇒ 90 ms (24 VDC or Less), 65 ms (48 VDC or More) OFF Operation: 8 ms ⇒ 20 ms
			Coil Properties (Input)	Low Input (9W ⇒ 24 VDC or Less: 2.2W, 48 VDC or More: 3.3W)
			Coil (Polarity)	N/A ⇒ Available
			External Dimensions [H x W x D] (mm)	Equivalent (127 x 63 x 113 ⇒ 128 x 63 x 109)
			Mounting Dimension (Recommended mounting hole pitch)	Compatible
Contact Arrangement			Identical	
Terminal Cover			Changed to Standard Equipment	
Terminal Screw Size	Identical (Main: M4, Coil/Auxiliary: M3.5)			
Applicable Wire Size [φ mm, mm ²] (Bare Wire)	Equivalent			
Applicable Crimp Lug Size	Identical			

[DC Operated Type]

Model Name		Item	New MSOD-T Series Support for Structure/Rating
Existing (S-N Series) (Number of Auxiliary Contacts)	New (S-T Series) (Number of Auxiliary Contacts)		
MSOD-N35 [4]	MSOD-T35 [4]	Rating (Main Circuit)	Identical
		Rating (Auxiliary Circuit)	Identical
		Rating (Coil)	Identical Range
		Coil (Operating Time)	Equivalent
		Coil (Input)	Equivalent
		Coil (Polarity)	Identical (N/A)
		External Dimensions [H x W x D] (mm)	Identical
		Mounting Dimension (Recommended mounting hole pitch)	Identical
		Contact Arrangement	Identical
		Terminal Cover	Changed to Standard Equipment
		Terminal Screw Size	Identical
		Applicable Wire Size [φ mm, mm ²] (Bare Wire)	Different Main: 2 - 5.5 (At Load Side with Heater Designation 15A or Less) ⇒ Power Source Side 1.25 - 16 Load Side 1.25 - 14 Coil/Auxiliary: φ 1.6, 1.25 - 2 ⇒ φ 1.6, 0.75 - 2.5
		Applicable Crimp Lug Size	Identical
MSOD-N50 [4]	MSOD-T50 [4]	Rating (Main Circuit)	Identical
		Rating (Auxiliary Circuit)	Identical
		Rating (Coil)	Identical Range
		Coil Properties (Operating Time)	Equivalent
		Coil Properties (Input)	Low Input (18W ⇒ 9W)
		Coil (Polarity)	Identical (N/A)
		External Dimensions [H x W x D] (mm)	Smaller (161.5 x 90 x 133 ⇒ 136.5 (- 22A Designation), 157.5 (29A Designation -) x 75 x 123)
		Mounting Dimension (Recommended mounting hole pitch)	Not Compatible (Compatible with Adapter)
		Contact Arrangement	Identical
		Terminal Cover	Changed to Standard Equipment
		Terminal Screw Size	Different (- 22A Designation -- Main: M6, Coil/Auxiliary: M4 ⇒ Main (Power Supply Side/Load Side): M5/M4, Coil/Auxiliary: M3.5) (29A Designation - -- Main: M6, Coil/Auxiliary: M4 ⇒ Main (Power Supply Side/Load Side): M5/M5, Coil/Auxiliary: M3.5)
		Applicable Wire Size [φ mm, mm ²] (Bare Wire)	Different Main : - ⇒ Power Supply Side 1.25 - 16 Load Side 1.25 - 14 Coil/Auxiliary: φ 1.6, 1.25 - 2 ⇒ φ 1.6, 0.75 - 2.5
		Applicable Crimp Lug Size	Different (Main) (- 22A Designation -- 1.25-6 - 22-6 ⇒ (Power Supply Side/Load Side)1.25-5 - 22-5/1.25-4 - 5.5-4) (29A Designation - -1.25-6 - 22-6 ⇒ 1.25-5 - 22-5 Different (Auxiliary/Coil) [1.25-4 - 2-4 ⇒ 1.25-3.5 - 2-3.5]
MSOD-N65 [4]	MSOD-T65 [4]	Rating (Main Circuit)	Identical
		Rating (Auxiliary Circuit)	Identical
		Rating (Coil)	Identical Range
		Coil Properties (Operating Time)	Equivalent
		Coil Properties (Input)	Equivalent
		Coil (Polarity)	Identical (N/A)
		External Dimensions [H x W x D] (mm)	Identical
		Mounting Dimension (Recommended mounting hole pitch)	Identical
		Contact Arrangement	Identical
		Terminal Cover	Equivalent (Special Product or Optional Support)
		Terminal Screw Size	Identical
		Applicable Crimp Lug Size	Identical
		MSOD-N80 [4]	MSOD-T80 [4]
Rating (Auxiliary Circuit)	Identical		
Rating (Coil)	Identical Range		
Coil Properties (Operating Time)	ON: 75ms ⇒ 50ms, OFF: 18ms ⇒ 13ms		
Coil Properties (Input)	Low Input (24W ⇒ 18W)		
Coil (Polarity)	Identical (N/A)		
External Dimensions [H x W x D] (mm)	Smaller (189.5 (- 54A Designation), 206 (67A Designation) x 100 x 157 ⇒ 160(- 54A Designation), 171.5 (67A Designation) x 90 x 133)		
Mounting Dimension (Recommended mounting hole pitch)	Not Compatible (Compatible with Adapter)		
Contact Arrangement	Identical		
Terminal Cover	Identical (N/A)		
Terminal Screw Size	Identical		
Applicable Crimp Lug Size	Different (Main) [(Power Supply Side/Load Side) 1.25-6 - 60-6/14-6 - 22-6, 38-S6 ⇒ 1.25-6 - 22-6, 38-S6/14-6 - 22-6, 38-S6] Identical (Auxiliary/Coil)		
MSOD-N95 [4]	MSOD-T100 [4]		
		Rating (Auxiliary Circuit)	Identical
		Rating (Coil)	Identical Range
		Coil Properties (Operating Time)	Equivalent
		Coil Properties (Input)	Equivalent
		Coil (Polarity)	Identical (N/A)
		External Dimensions [H x W x D] (mm)	Equivalent (206 x 100 x 157 ⇒ 201 x 100 x 157)
		Mounting Dimension (Recommended mounting hole pitch)	Identical
		Contact Arrangement	Identical
		Terminal Cover	Identical (Optional Support)
		Terminal Screw Size	Identical
		Applicable Crimp Lug Size	Identical

1.3 Magnetic Contactors

[AC Operated Type]

Model Name		Item	New S-T Series Support for Structure/Rating
Existing (S-N Series) [Number of Auxiliary Contacts]	New (S-T Series) [Number of Auxiliary Contacts]		
S-N10 [1]	S-T10 [1]	Rating (Main Circuit)	Equivalent
		Rating (Auxiliary Circuit)	Identical
		Rating (Coil)	Expanded Rating Range
		External Dimensions [H x W x D] (mm)	Smaller (78 x 43 x 78 ⇒ 75 x 36 x 78)
		Mounting Dimension (Recommended mounting hole pitch)	Not Compatible (Compatible with Adapter)
		Contact Arrangement	Identical
		Terminal Cover	Changed to Standard Equipment
		Terminal Screw Size	Identical (M3.5)
		Applicable Wire Size [φ mm, mm ²] (Bare Wire)	Equivalent
		Applicable Crimp Lug Size	Identical
S-N11 [1]	S-T12 [2]	Rating (Main Circuit)	Equivalent
		Rating (Auxiliary Circuit)	Identical
		Rating (Coil)	Expanded Rating Range
		External Dimensions [H x W x D] (mm)	Equivalent (78 x 43 x 78 ⇒ 75 x 44 x 78)
		Mounting Dimension (Recommended mounting hole pitch)	Compatible (35 x 50)
		Contact Arrangement	Increased Auxiliary Contacts (1-Pole ⇒ 2-Pole)
		Terminal Cover	Changed to Standard Equipment
		Terminal Screw Size	Identical (M3.5)
		Applicable Wire Size [φ mm, mm ²] (Bare Wire)	Equivalent
		Applicable Crimp Lug Size	Identical
S-N12 [2]	S-T12 [2]	Rating (Main Circuit)	Equivalent
		Rating (Auxiliary Circuit)	Identical
		Rating (Coil)	Expanded Rating Range
		External Dimensions [H x W x D] (mm)	Smaller (78 x 53 x 78 ⇒ 75 x 44 x 78)
		Mounting Dimension (Recommended mounting hole pitch)	Not Compatible (Compatibility with Adapter Planned)
		Contact Arrangement	Identical
		Terminal Cover	Changed to Standard Equipment
		Terminal Screw Size	Identical (M3.5)
		Applicable Wire Size [φ mm, mm ²] (Bare Wire)	Equivalent
		Applicable Crimp Lug Size	Identical
S-N18 [0]	S-T32 [0]	Rating (Main Circuit)	Equivalent or Higher
		Rating (Coil)	Expanded Rating Range
		External Dimensions [H x W x D] (mm)	Equivalent (79 x 43 x 81 ⇒ 81 x 43 x 81)
		Mounting Dimension (Recommended mounting hole pitch)	Compatible
		Contact Arrangement	Identical
	S-T20 [2]	Rating (Main Circuit)	Equivalent (Rated Motor Load AC-3)
		Rating (Coil)	Expanded Rating Range
		External Dimensions [H x W x D] (mm)	Equivalent (79 x 43 x 81 ⇒ 75 x 44 x 78)
		Mounting Dimension (Recommended mounting hole pitch)	Compatible (30 x 60)
		Contact Arrangement	Increased Auxiliary Contacts (0-Pole ⇒ 2-Pole)
S-N20 [2] (Motor Load/ Resistance Load)	(Motor Load/ Resistance Load)	Terminal Cover	Changed to Standard Equipment
		Terminal Screw Size	Identical (Main: M4, Coil: M3.5)
		Applicable Wire Size [φ mm, mm ²] (Bare Wire)	Equivalent
		Applicable Crimp Lug Size	Identical
		Rating (Main Circuit)	Almost Equivalent (Rated Motor Load AC-3 AC200 - 440V 20A ⇒ 18A) * Low Rated Resistance Load
		Rating (Auxiliary Circuit)	Identical
		Rating (Coil)	Expanded Rating Range
		External Dimensions [H x W x D] (mm)	Smaller (81 x 63 x 81 ⇒ 75 x 44 x 78)
		Mounting Dimension (Recommended mounting hole pitch)	Not Compatible (Compatible with Adapter)
		Contact Arrangement	Identical
S-N20 [2] (Resistance Load)	S-T21 [4] (Resistance Load)	Terminal Cover	Changed to Standard Equipment
		Terminal Screw Size	Identical (Main: M4, Coil/Auxiliary: M3.5)
		Applicable Wire Size [φ mm, mm ²] (Bare Wire)	Different (Main: M4, Coil/Auxiliary: M3.5 ⇒ Main: M3.5, Coil/Auxiliary: M3.5)
		Applicable Crimp Lug Size	Different (Main: φ 1.6 - φ 2.6, 2 - 5.5, Coil/Auxiliary: φ 1.6, 1.25 - 2 ⇒ Main: φ 1.6, 0.75 - 2.5, Coil/Auxiliary: φ 1.6, 0.75 - 2.5)
		Rating (Main Circuit)	Equivalent (Rated Resistance Load AC-1)
		Rating (Auxiliary Circuit)	Identical
		Rating (Coil)	Expanded Rating Range
		External Dimensions [H x W x D] (mm)	Identical (81 x 63 x 81 ⇒ 81 x 63 x 81)
		Mounting Dimension (Recommended mounting hole pitch)	Compatible
		Contact Arrangement	Increased Auxiliary Contacts (2-Pole ⇒ 4-Pole)
S-N21 [4]	S-T21 [4]	Terminal Cover	Changed to Standard Equipment
		Terminal Screw Size	Identical (Main: M4, Coil/Auxiliary: M3.5)
		Applicable Wire Size [φ mm, mm ²] (Bare Wire)	Equivalent
		Applicable Crimp Lug Size	Identical
		Rating (Main Circuit)	Equivalent
		Rating (Auxiliary Circuit)	Identical
		Rating (Coil)	Expanded Rating Range
		External Dimensions [H x W x D] (mm)	Identical (81 x 63 x 81 ⇒ 81 x 63 x 81)
		Mounting Dimension (Recommended mounting hole pitch)	Compatible
		Contact Arrangement	Identical
S-N25 [4] (Motor Load/ Resistance Load)	S-T25 [4] (Motor Load/ Resistance Load)	Terminal Cover	Changed to Standard Equipment
		Terminal Screw Size	Different (Main: M5, Coil/Auxiliary: M3.5 ⇒ Main: M4, Coil/Auxiliary: M3.5)
		Applicable Wire Size [φ mm, mm ²] (Bare Wire)	Different (Main: - Coil/Auxiliary: φ 1.6, 1.25 - 2 ⇒ Main: φ 1.6 - φ 2.6, 1.25 - 6 Coil/Auxiliary: φ 1.6, 0.75 - 2.5)
		Applicable Crimp Lug Size	Different (Main: 1.25-5 - 14-5, Coil/Auxiliary: 1.25-3.5 - 2-3.5 ⇒ Main: 1.25-4 - 5.5-4, Coil/Auxiliary: 1.25-3.5 - 2-3.5)
		Rating (Main Circuit)	Equivalent or Higher (Rated Motor Load AC-3) * Low Rated Resistance Load
		Rating (Auxiliary Circuit)	Identical
		Rating (Coil)	Expanded Rating Range
		External Dimensions [H x W x D] (mm)	Smaller (89 x 75 x 91 ⇒ 81 x 63 x 81)
		Mounting Dimension (Recommended mounting hole pitch)	Not Compatible (Compatible with Adapter)
		Contact Arrangement	Identical

[AC Operated Type]

Model Name		Item	New S-T Series Support for Structure/Rating
Existing (S-N Series) (Number of Auxiliary Contacts)	New (S-T Series) (Number of Auxiliary Contacts)		
S-N25 [4] (Resistance Load)	S-T35 [4] (Resistance Load)	Rating (Main Circuit)	Equivalent (Rated Resistance Load AC-1)
		Rating (Auxiliary Circuit)	Identical
		Rating (Coil)	Expanded Rating Range
		External Dimensions [H x W x D] (mm)	Identical
		Mounting Dimension (Recommended mounting hole pitch)	Identical
		Contact Arrangement	Identical
		Terminal Cover	Changed to Standard Equipment
		Terminal Screw Size	Identical
		Applicable Wire Size [φ mm, mm ²] (Bare Wire)	Different (Main: - Coil/Auxiliary: φ 1.6, 1.25 - 2 ⇒ Main: φ 1.6 - φ 3.6, 1.25 - 16 Coil/Auxiliary: φ 1.6, 0.75 - 2.5)
		Applicable Crimp Lug Size	Identical
S-N28 [0]	S-T32 [0]	Rating (Main Circuit)	Equivalent or Higher
		Rating (Coil)	Expanded Rating Range
		External Dimensions [H x W x D] (mm)	Equivalent (79 x 43 x 81 ⇒ 81 x 43 x 81)
		Mounting Dimension (Recommended mounting hole pitch)	Compatible
		Contact Arrangement	Identical
		Terminal Cover	Changed to Standard Equipment
		Terminal Screw Size	Identical (Main: M4, Coil: M3.5)
		Applicable Wire Size [φ mm, mm ²] (Bare Wire)	Equivalent
		Applicable Crimp Lug Size	Identical
		S-N35 [4]	S-T35 [4]
Rating (Auxiliary Circuit)	Identical		
Rating (Coil)	Expanded Rating Range		
Coil Properties (Operating Time)	Equivalent		
Coil Properties (Input)	Equivalent		
Coil Surge Absorber Function	Identical (Optional Support)		
External Dimensions [H x W x D] (mm)	Identical		
Mounting Dimension (Recommended mounting hole pitch)	Identical		
Contact Arrangement	Identical		
Terminal Cover	Changed to Standard Equipment		
S-N50 [4]	S-T50 [4]	Rating (Main Circuit)	Identical
		Rating (Auxiliary Circuit)	Identical
		Rating (Coil)	Different in Part (300 VAC--260 - 350 VAC ⇒ 260 - 300 VAC), Identical Range for Others
		Coil Properties (Operating Time)	ON Operation: 20 - 30 ms ⇒ 10 - 20 ms, OFF Operation: 35 - 65 ms ⇒ 5 - 14 ms
		Coil Properties (Input)	Different (2.2W ⇒ 3.8W)
		Coil Surge Absorber Function	Different (Standard Type ⇒ Optional Support)
		External Dimensions [H x W x D] (mm)	Smaller (106 x 88 x 106 ⇒ 89 x 75 x 91)
		Mounting Dimension (Recommended mounting hole pitch)	Not Compatible (Compatible with Adapter)
		Contact Arrangement	Identical
		Terminal Cover	Changed to Standard Equipment
S-N65 [4]	S-T65 [4]	Rating (Main Circuit)	Identical
		Rating (Auxiliary Circuit)	Identical
		Rating (Coil)	Identical Range
		Coil Properties (Operating Time)	Identical
		Coil Properties (Input)	Identical
		Coil Surge Absorber Function	Equivalent (Standard Equipment)
		External Dimensions [H x W x D] (mm)	Identical
		Mounting Dimension (Recommended mounting hole pitch)	Identical
		Contact Arrangement	Identical
		Terminal Cover	Equivalent (Special Product or Optional Support)
S-N80 [4] (Motor Load/ Resistance Load)	S-T80 [4] (Motor Load/ Resistance Load)	Rating (Main Circuit)	Equivalent (Rated Motor Load AC-3) * Low Rated Resistance Load
		Rating (Auxiliary Circuit)	Identical
		Rating (Coil)	Identical Range
		Coil Properties (Operating Time)	ON Operation: Equivalent, OFF Operation: 50 - 100 ms ⇒ 35 - 65 ms
		Coil Properties (Input)	Low Input (2.8W ⇒ 2.2W)
		Coil Surge Absorber Function	Equivalent (Standard Equipment)
		External Dimensions [H x W x D] (mm)	Smaller (124 x 100 x 127 ⇒ 106 x 88 x 106)
		Mounting Dimension (Recommended mounting hole pitch)	Not Compatible (Compatible with Adapter)
		Contact Arrangement	Identical
		Terminal Cover	Equivalent (Special Product or Optional Support)
S-N80 [4] (Resistance Load)	S-T100 [4] (Resistance Load)	Rating (Main Circuit)	Equivalent or Higher (Rated Resistance Load AC-1)
		Rating (Auxiliary Circuit)	Identical
		Rating (Coil)	Identical Range
		Coil Properties (Operating Time)	Identical
		Coil Properties (Input)	Identical
		Coil Surge Absorber Function	Equivalent (Standard Equipment)
		External Dimensions [H x W x D] (mm)	Identical
		Mounting Dimension (Recommended mounting hole pitch)	Identical
		Contact Arrangement	Identical
		Terminal Cover	Identical (Optional Support)
S-N95 [4]	S-T100 [4]	Rating (Main Circuit)	Identical
		Rating (Auxiliary Circuit)	Identical
		Rating (Coil)	Identical Range
		Coil Properties (Operating Time)	Identical
		Coil Properties (Input)	Identical
		Coil Surge Absorber Function	Equivalent (Standard Equipment)
		External Dimensions [H x W x D] (mm)	Identical
		Mounting Dimension (Recommended mounting hole pitch)	Identical
		Contact Arrangement	Identical
		Terminal Cover	Identical (Optional Support)

[DC Operated Type]

Model Name		Item	New SD-T Series Support for Structure/Rating	
Existing (SD-N Series) [Number of Auxiliary Contacts]	New (SD-T Series) [Number of Auxiliary Contacts]			
SD-N11 [1]	SD-T12 [2]	Rating (Main Circuit)	Equivalent	
		Rating (Auxiliary Circuit)	Identical	
		Rating (Coil)	Identical Range	
		Coil Properties (Operating Time)	ON Operation: 45 ms ⇒ 85 ms (24 VDC or Less), 60 ms (48 VDC or More) OFF Operation: 13 ms ⇒ 10 ms	
		Coil Properties (Input)	Low Input (7W ⇒ 24 VDC or Less: 2.2W, 48 VDC or More: 3.3W)	
		Coil (Polarity)	N/A ⇒ Available	
		External Dimensions [H x W x D] (mm)	Equivalent (78 x 43 x 110 ⇒ 75 x 44 x 100)	
		Mounting Dimension (Recommended mounting hole pitch)	Compatible	
		Contact Arrangement	Increased Auxiliary Contacts (1-Pole ⇒ 2-Pole)	
		Terminal Cover	Changed to Standard Equipment	
		Terminal Screw Size	Identical (M3.5)	
		Applicable Wire Size [φ mm, mm ²] (Bare Wire)	Equivalent	
Applicable Crimp Lug Size	Identical			
SD-N12 [2]	SD-T12 [2]	Rating (Main Circuit)	Equivalent	
		Rating (Auxiliary Circuit)	Identical	
		Rating (Coil)	Identical Range	
		Coil Properties (Operating Time)	ON Operation: 45 ms ⇒ 85 ms (24 VDC or Less), 60 ms (48 VDC or More) OFF Operation: 13 ms ⇒ 10 ms	
		Coil Properties (Input)	Low Input (7W ⇒ 24 VDC or Less: 2.2W, 48 VDC or More: 3.3W)	
		Coil (Polarity)	N/A ⇒ Available	
		External Dimensions [H x W x D] (mm)	Smaller (78 x 53 x 110 ⇒ 75 x 44 x 100)	
		Mounting Dimension (Recommended mounting hole pitch)	Not Compatible (Compatible with Adapter)	
		Contact Arrangement	Identical	
		Terminal Cover	Changed to Standard Equipment	
		Terminal Screw Size	Identical (M3.5)	
		Applicable Wire Size [φ mm, mm ²] (Bare Wire)	Equivalent	
Applicable Crimp Lug Size	Identical			
SD-N21 [4] (Motor Load/ Resistance Load)	(Motor Load/ Resistance Load)	Rating (Main Circuit)	Almost Equivalent (Rated Motor Load AC-3 AC200 - 440V 20A ⇒ 18A) * Low Rated Resistance Load	
		Rating (Auxiliary Circuit)	Identical	
		Rating (Coil)	Identical Range	
		Coil Properties (Operating Time)	ON Operation: 50 ms ⇒ 85 ms (24 VDC or Less), 60 ms (48 VDC or More) OFF Operation: 8 ms ⇒ 10 ms	
		Coil Properties (Input)	Low Input (9W ⇒ 24 VDC or Less: 2.2W, 48 VDC or More: 3.3W)	
		Coil (Polarity)	N/A ⇒ Available	
		External Dimensions [H x W x D] (mm)	Smaller (81 x 63 x 113 ⇒ 75 x 44 x 100)	
		Mounting Dimension (Recommended mounting hole pitch)	Not Compatible (Compatible with Adapter)	
		Contact Arrangement	Reduced Auxiliary Contacts (4-Pole ⇒ 2-Pole)	
		Terminal Cover	Changed to Standard Equipment	
		Terminal Screw Size	Different (Main: M4, Coil/Auxiliary: M3.5 ⇒ Main: M3.5, Coil/Auxiliary: M3.5)	
		Applicable Wire Size [φ mm, mm ²] (Bare Wire)	Different (Main: φ 1.6 - φ 2.6, 2 - 5.5 Coil/Auxiliary: φ 1.6, 1.25 - 2 ⇒ Main: φ 1.6, 0.75 - 2.5 Coil/Auxiliary: φ 1.6, 0.75 - 2.5)	
	Applicable Crimp Lug Size	Different (Main: 1.25-4 - 5.5-4, Coil/Auxiliary: 1.25-3.5 - 2-3.5 ⇒ Main: 1.25-3.5 - 2-3.5 5.5-S3, Coil/Auxiliary: 1.25-3.5 - 2-3.5)		
	(Motor Load/ Resistance Load)	SD-T21 [4] (Motor Load/ Resistance Load)	Rating (Main Circuit)	Equivalent
			Rating (Auxiliary Circuit)	Identical
			Rating (Coil)	Identical Range
			Coil Properties (Operating Time)	ON Operation: 50 ms ⇒ 90 ms (24 VDC or Less), 65 ms (48 VDC or More) OFF Operation: 8 ms ⇒ 20 ms
			Coil Properties (Input)	Low Input (9W ⇒ 24 VDC or Less: 2.2W, 48 VDC or More: 3.3W)
			Coil (Polarity)	N/A ⇒ Available
			External Dimensions [H x W x D] (mm)	Equivalent (81 x 63 x 113 ⇒ 81 x 63 x 108)
			Mounting Dimension (Recommended mounting hole pitch)	Compatible
			Contact Arrangement	Identical
			Terminal Cover	Changed to Standard Equipment
			Terminal Screw Size	Identical (Main: M4, Coil/Auxiliary: M3.5)
Applicable Wire Size [φ mm, mm ²] (Bare Wire)			Equivalent	
Applicable Crimp Lug Size	Identical			

[DC Operated Type]

Model Name		Item	New SD-T Series Support for Structure/Rating
Existing (SD-N Series) [Number of Auxiliary Contacts]	New (SD-T Series) [Number of Auxiliary Contacts]		
SD-N35 [4]	SD-T35 [4]	Rating (Main Circuit)	Identical
		Rating (Auxiliary Circuit)	Identical
		Rating (Coil)	Identical Range
		Coil Properties (Operating Time)	Equivalent
		Coil Properties (Input)	Equivalent
		Coil (Polarity)	Identical (N/A)
		External Dimensions [H x W x D] (mm)	Identical
		Mounting Dimension (Recommended mounting hole pitch)	Identical
		Contact Arrangement	Identical
		Terminal Cover	Changed to Standard Equipment
		Terminal Screw Size	Identical
		Applicable Wire Size [φ mm, mm ²] (Bare Wire)	Different (Main: - Coil/Auxiliary: φ 1.6, 1.25 - 2 ⇒ Main: φ 1.6 - φ 3.6, 1.25 - 16 Coil/Auxiliary: φ 1.6, 0.75 - 2.5)
		Applicable Crimp Lug Size	Identical
SD-N50 [4]	SD-T50 [4]	Rating (Main Circuit)	Identical
		Rating (Auxiliary Circuit)	Identical
		Rating (Coil)	Identical Range
		Coil Properties (Operating Time)	Equivalent
		Coil Properties (Input)	Low Input (18W ⇒ 9W)
		Coil (Polarity)	Identical (N/A)
		External Dimensions [H x W x D] (mm)	Smaller (107.5 x 88 x 133 ⇒ 89 x 75 x 123)
		Mounting Dimension (Recommended mounting hole pitch)	Not Compatible (Compatible with Adapter)
		Contact Arrangement	Identical
		Terminal Cover	Changed to Standard Equipment
		Terminal Screw Size	Different (Main: M6, Coil/Auxiliary: M4 ⇒ Main: M5, Coil/Auxiliary: M3.5)
		Applicable Wire Size [φ mm, mm ²] (Bare Wire)	Different (Main: - Coil/Auxiliary: φ 1.6, 1.25 - 2 ⇒ Main: φ 1.6 - φ 3.6, 1.25 - 16 Coil/Auxiliary: φ 1.6, 0.75 - 2.5)
		Applicable Crimp Lug Size	Different (Main: 1.25-6 - 22-6, Coil/Auxiliary: 1.25-4 - 2-4 ⇒ Main: 1.25-5 - 22-5, 1.25-3.5 - 2-3.5)
SD-N65 [4]	SD-T65 [4]	Rating (Main Circuit)	Identical
		Rating (Auxiliary Circuit)	Identical
		Rating (Coil)	Identical Range
		Coil Properties (Operating Time)	Equivalent
		Coil Properties (Input)	Equivalent
		Coil (Polarity)	Identical (N/A)
		External Dimensions [H x W x D] (mm)	Equivalent (107.5 x 88 x 133 ⇒ 106 x 88 x 133)
		Mounting Dimension (Recommended mounting hole pitch)	Identical
		Contact Arrangement	Identical
		Terminal Cover	Equivalent (Special Product or Optional Support)
		Terminal Screw Size	Identical
		Applicable Crimp Lug Size	Identical
		SD-N80 [4] (Motor Load/ Resistance Load)	SD-T80 [4] (Motor Load/ Resistance Load)
Rating (Auxiliary Circuit)	Identical		
Rating (Coil)	Identical Range		
Coil Properties (Operating Time)	ON: 75ms ⇒ 50ms, OFF: 18ms ⇒ 13ms		
Coil Properties (Input)	Low Input (24W ⇒ 18W)		
Coil (Polarity)	Identical (N/A)		
External Dimensions [H x W x D] (mm)	Smaller (134 x 100 x 157 ⇒ 106 x 88 x 133)		
Mounting Dimension (Recommended mounting hole pitch)	Not Compatible (Compatible with Adapter)		
Contact Arrangement	Identical		
Terminal Cover	Identical (N/A)		
Terminal Screw Size	Identical		
Applicable Crimp Lug Size	Difference (Main) [1.25-6 - 60-6 ⇒ 1.25-6 - 60-S6] Identical (Auxiliary/Coil)		
SD-N80 [4] (Resistance Load)	SD-T100 [4] (Resistance Load)		
		Rating (Auxiliary Circuit)	Identical
		Rating (Coil)	Identical Range
		Coil Properties (Operating Time)	Identical
		Coil Properties (Input)	Identical
		Coil (Polarity)	Identical (N/A)
		External Dimensions [H x W x D] (mm)	Identical
		Mounting Dimension (Recommended mounting hole pitch)	Identical
		Contact Arrangement	Identical
		Terminal Cover	Identical (Optional Support)
		Terminal Screw Size	Identical
		Applicable Crimp Lug Size	Identical
		SD-N95 [4]	SD-T100 [4]
Rating (Auxiliary Circuit)	Identical		
Rating (Coil)	Identical Range		
Coil Properties (Operating Time)	Identical		
Coil Properties (Input)	Identical		
Coil (Polarity)	Identical (N/A)		
External Dimensions [H x W x D] (mm)	Identical		
Mounting Dimension (Recommended mounting hole pitch)	Identical		
Contact Arrangement	Identical		
Terminal Cover	Identical (Optional Support)		
Terminal Screw Size	Identical		
Applicable Crimp Lug Size	Identical		

[Mechanically Latched (AC Operated/DC Operated)]

Model Name		Item	New S-T Series Support for Structure/Rating
Existing (S-N Series) [Number of Auxiliary Contacts (Valid)]	New (S-T Series) [Number of Auxiliary Contacts (Valid)]		
SL(D)-N21 [4]	SL(D)-T21 [4]	Rating (Main Circuit)	Identical
		Rating (Auxiliary Circuit)	Identical
		Rating (Coil)	Identical
		Coil Properties (Momentary Input)	Low Input (AC Operation Closing: 220VA ⇒ 80VA AC Operation Tripping: 280VA ⇒ 110VA DC Operation Closing: 100VA ⇒ 40VA DC Operation Closing: 190VA ⇒ 150VA)
		External Dimensions [H x W x D] (mm)	Identical
		Mounting Dimension (Recommended mounting hole pitch)	Compatible
		Contact Arrangement	Identical
		Terminal Cover	Changed to Standard Equipment
		Terminal Screw Size	Identical
		Applicable Wire Size [φ mm, mm ²] (Bare Wire)	Equivalent
		Applicable Crimp Lug Size	Identical
SL(D)-N35 [4]	SL(D)-T35 [4]	Rating (Main Circuit)	Identical
		Rating (Auxiliary Circuit)	Identical
		Rating (Coil)	Identical
		Coil Properties (Momentary Input)	Low Input (in part) (AC Operation Closing: 220VA ⇒ 120VA AC Operation Tripping: 280VA ⇒ 150VA DC Operation Closing: 100VA ⇒ 100VA (Identical) DC Operation Closing: 190VA ⇒ 150VA)
		External Dimensions [H x W x D] (mm)	Equivalent (89 x 75 x 146.5 ⇒ 89 x 75 x 145.6)
		Mounting Dimension (Recommended mounting hole pitch)	Compatible
		Contact Arrangement	Identical
		Terminal Cover	Changed to Standard Equipment
		Terminal Screw Size	Identical
		Applicable Wire Size [φ mm, mm ²] (Bare Wire)	Different (Main: - Coil/Auxiliary: φ 1.6, 1.25 - 2 ⇒ Main: φ 1.6 - φ 3.6, 1.25 - 16 Coil/Auxiliary: φ 1.6, 0.75 - 2.5)
		Applicable Crimp Lug Size	Identical
SL(D)-N50 [4]	SL(D)-T50 [4]	Rating (Main Circuit)	Identical
		Rating (Auxiliary Circuit)	Identical
		Rating (Coil)	Identical
		Coil Properties (Momentary Input)	Low Input (in part) (AC Operation Closing: 120VA ⇒ 120VA AC Operation Tripping: 250VA ⇒ 150VA DC Operation Closing: 120VA ⇒ 100VA DC Operation Closing: 200VA ⇒ 150VA)
		External Dimensions [H x W x D] (mm)	Different (106 x 88 x 135.5 ⇒ 89 x 75 x 145.6)
		Mounting Dimension (Recommended mounting hole pitch)	Not Compatible (Compatible with Adapter)
		Contact Arrangement	Identical
		Terminal Cover	Changed to Standard Equipment
		Terminal Screw Size	Different (Main: M6, Coil/Auxiliary: M4 ⇒ Main: M5, Coil/Auxiliary: M3.5)
		Applicable Wire Size [φ mm, mm ²] (Bare Wire)	Different (Main: - Coil/Auxiliary: φ 1.6, 1.25 - 2 ⇒ Main: φ 1.6 - φ 3.6, 1.25 - 16 Coil/Auxiliary: φ 1.6, 0.75 - 2.5)
		Applicable Crimp Lug Size	Different (Main: 1.25-6 - 22-6, Coil/Auxiliary: 1.25-4 - 2-4 ⇒ Main: 1.25-5 - 22-5, 1.25-3.5 - 2-3.5)
SL(D)-N50FN [4] (Class 2 Heat-Resistant)	SL(D)-T50FN [4] (Class 2 Heat-Resistant)	Rating (Main Circuit)	Identical
		Rating (Auxiliary Circuit)	Identical
		Rating (Coil)	Identical
		Coil Properties (Momentary Input)	Identical
		External Dimensions [H x W x D] (mm)	Identical
		Mounting Dimension (Recommended mounting hole pitch)	Compatible
		Contact Arrangement	Identical
		Terminal Cover	Equivalent (Special Product or Optional Support)
		Terminal Screw Size	Identical
		Applicable Crimp Lug Size	Identical

[Mechanically Latched (AC Operated/DC Operated)]

Model Name		Item	New S-T Series Support for Structure/Rating
Existing (S-N Series) [Number of Auxiliary Contacts (Valid)]	New (S-T Series) [Number of Auxiliary Contacts (Valid)]		
SL(D)-N65 [4]	SL(D)-T65 [4]	Rating (Main Circuit)	Identical
		Rating (Auxiliary Circuit)	Identical
		Rating (Coil)	Identical
		Coil Properties (Momentary Input)	Identical
		External Dimensions [H x W x D] (mm)	Identical
		Mounting Dimension (Recommended mounting hole pitch)	Compatible
		Contact Arrangement	Identical
		Terminal Cover	Equivalent (Special Product or Optional Support)
		Terminal Screw Size	Identical
		Applicable Crimp Lug Size	Identical
SL(D)-N80 [3] (Motor Load/ Resistance Load)	SL(D)-T80 [4] (Motor Load/ Resistance Load)	Rating (Main Circuit)	Equivalent (Rated Motor Load AC-3) * Low Rated Resistance Load
		Rating (Auxiliary Circuit)	Identical
		Rating (Coil)	Identical
		Coil Properties (Momentary Input)	Low Input (in part) (AC Operation Closing: 250VA ⇒ 120VA AC Operation Tripping: 250VA ⇒ 250VA DC Operation Closing: 250VA ⇒ 120VA DC Operation Closing: 300VA ⇒ 200VA)
		External Dimensions [H x W x D] (mm)	Different (172 x 100 x 127 ⇒ 106 x 88 x 135.5)
		Mounting Dimension (Recommended mounting hole pitch)	Not Compatible (Compatible with Adapter)
		Contact Arrangement	Increased Number of Valid Auxiliary Contacts (1a2b ⇒ 2a2b)
		Terminal Cover	Equivalent (Optional Support)
		Terminal Screw Size	Identical
		Applicable Crimp Lug Size	Difference (Main) [1.25-6 - 60-6 ⇒ 1.25-6 - 60-S6] Identical (Auxiliary/Coil)
SL(D)-N80 [3] (Resistance Load)	SL(D)-T100 [3] (Resistance Load)	Rating (Main Circuit)	Equivalent or Higher (Rated Resistance Load AC-1)
		Rating (Auxiliary Circuit)	Identical
		Rating (Coil)	Identical
		Coil Properties (Momentary Input)	Identical
		External Dimensions [H x W x D] (mm)	Identical
		Mounting Dimension (Recommended mounting hole pitch)	Compatible
		Contact Arrangement	Identical
		Terminal Cover	Equivalent (Optional Support)
		Terminal Screw Size	Identical
		Applicable Crimp Lug Size	Identical
SL(D)-N95 [3]	SL(D)-T100 [3]	Rating (Main Circuit)	Identical
		Rating (Auxiliary Circuit)	Identical
		Rating (Coil)	Identical
		Coil Properties (Momentary Input)	Identical
		External Dimensions [H x W x D] (mm)	Identical
		Mounting Dimension (Recommended mounting hole pitch)	Compatible
		Contact Arrangement	Identical
		Terminal Cover	Equivalent (Optional Support)
		Terminal Screw Size	Identical
		Applicable Crimp Lug Size	Identical

1.4 Thermal Overload Relays

Model Name		Item	New TH-T Series Support for Structure/Rating
Existing (TH-N Series)	New (TH-T Series)		
TH-N12	TH-T18	Heater Designation	0.12 - 11A ⇒ 0.12 - 15A
		External Dimensions [H x W x D] (mm)	Equivalent (55 x 45 x 76.5 ⇒ 55 x 46 x 76.5)
		Mounting Type	Identical (For Magnetic Starters. Combine with Independent Mounting Unit UT-HZ18 for Independent Mounting)
		Frame of the Combined Magnetic Contactor	N10, N11, N12 ⇒ T10, T12, T20
		Terminal Cover	Changed to Standard Equipment
		Terminal Screw Size	Identical (M3.5)
		Applicable Wire Size [φ mm, mm ²] (Bare Wire)	Equivalent
		Applicable Crimp Lug Size	Identical
TH-N18	TH-T18	Heater Designation	1.3 - 15A ⇒ 0.12 - 15A
		External Dimensions [H x W x D] (mm)	Smaller (59 x 54 x 80 ⇒ 55 x 46 x 76.5)
		Mounting Type	For Magnetic Starters ⇒ For Magnetic Starters. Combine with Independent Mounting Unit UT-HZ18 for Independent Mounting
		Frame of the Combined Magnetic Contactor	N18 ⇒ T10, T12, T20
		Terminal Cover	Changed to Standard Equipment
		Terminal Screw Size	Different (Main: M4, Auxiliary: M3.5 ⇒ Main: M3.5, Auxiliary: M3.5)
		Applicable Wire Size [φ mm, mm ²] (Bare Wire)	Different (Main: φ 1.6 - φ 2.6, 2 - 5.5 Auxiliary: φ 1.6, 1.25 - 2 ⇒ Main: φ 1.6, 0.75 - 2.5 Auxiliary: φ 1.6, 0.75 - 2.5)
		Applicable Crimp Lug Size	Different (Main: 1.25-4 - 5.5-4, Auxiliary: 1.25-3.5 - 2-3.5 ⇒ Main: 1.25-3.5 - 2-3.5 5.5-S3, Auxiliary: 1.25-3.5 - 2-3.5)
TH-N20	TH-T25	Heater Designation	0.24 - 15A ⇒ 0.24 - 22A
		External Dimensions [H x W x D] (mm)	Equivalent (51 x 63 x 79 ⇒ 53 x 63 x 80)
		Mounting Type	Identical (For Magnetic Starters, For Independent Mounting)
		Frame of the Combined Magnetic Contactor	N20, N21, N25, (N35) ⇒ T21, T25
		Terminal Cover	Changed to Standard Equipment
		Terminal Screw Size	Identical (Main: M4, Auxiliary: M3.5)
		Applicable Wire Size [φ mm, mm ²] (Bare Wire)	Equivalent
		Applicable Crimp Lug Size	Identical
TH-N20TA	TH-T50	Heater Designation	22 - 29A ⇒ 29 - 42A
		External Dimensions [H x W x D] (mm)	Identical
		Mounting Type	Identical (For Magnetic Starters, No Independent Mounting)
		Frame of the Combined Magnetic Contactor	N25, N35 ⇒ T35, T50
		Terminal Cover	Changed to Standard Equipment
		Terminal Screw Size	Identical
		Applicable Wire Size [φ mm, mm ²] (Bare Wire)	Different (Main: - Auxiliary: φ 1.6, 1.25 - 2 ⇒ Main: φ 2 - φ 3.6, 2 - 14 Auxiliary: φ 1.6, 0.75 - 2.5)
		Applicable Crimp Lug Size	Identical
TH-N60	TH-T65	Heater Designation	Identical
		External Dimensions [H x W x D] (mm)	Identical
		Mounting Type	Identical (For Magnetic Starters, For Independent Mounting)
		Frame of the Combined Magnetic Contactor	N50, N65 ⇒ T65, T80
		Terminal Cover	Identical (Optional Support)
		Terminal Screw Size	Identical
TH-N60TA	TH-T100	Heater Designation	Identical
		External Dimensions [H x W x D] (mm)	Equivalent (73.5 x 89 x 83.5 ⇒ 68.5 x 89 x 83.5)
		Mounting Type	Identical (For Magnetic Starters, No Independent Mounting)
		Frame of the Combined Magnetic Contactor	N80, N95 ⇒ T80, T100
		Terminal Cover	Identical (N/A)
		Terminal Screw Size	Identical
		Applicable Crimp Lug Size	Identical

1.5 Contactor Relays

[AC Operated]

Model Name		Item	New SR(D)-T Series Support for Structure/Rating
Existing (SR-N Series) [Number of Contacts]	New (SR-T Series) [Number of Contacts]		
SR-N4 [4]	SR-T5 [5]	Rating	Equivalent
		Rating (Coil)	Expanded Rating Range
		External Dimensions [H x W x D] (mm)	Equivalent (78 x 43 x 78 ⇒ 75 x 44 x 78)
		Mounting Dimension (Recommended mounting hole pitch)	Compatible
		Contact Arrangement (Note 1)	- ⇒ 5a, 4a ⇒ 4a1b, 3a1b ⇒ 3a2b, 2a2b ⇒ 3a2b
		Terminal Cover	Changed to Standard Equipment
		Terminal Screw Size	Identical (M3.5)
		Applicable Wire Size [ϕ mm, mm ²] (Bare Wire)	Equivalent
		Applicable Crimp Lug Size	Identical
		SR-N5 [5]	SR-T5 [5]
Rating (Coil)	Expanded Rating Range		
External Dimensions [H x W x D] (mm)	Smaller (78 x 53 x 78 ⇒ 75 x 44 x 78)		
Mounting Dimension (Recommended mounting hole pitch)	Not Compatible (Compatible with Adapter)		
Contact Arrangement (Note 1)	5a ⇒ 5a, 4a1b ⇒ 4a1b, 3a2b ⇒ 3a2b, 2a3b ⇒ -		
Terminal Cover	Changed to Standard Equipment		
Terminal Screw Size	Identical (M3.5)		
Applicable Wire Size [ϕ mm, mm ²] (Bare Wire)	Equivalent		
Applicable Crimp Lug Size	Identical		
SR-N8 [8]	SR-T9 [9]		
		Rating (Coil)	Expanded Rating Range
		External Dimensions [H x W x D] (mm)	Equivalent (78 x 43 x 106 ⇒ 75 x 44 x 108)
		Mounting Dimension (Recommended mounting hole pitch)	Compatible
		Contact Arrangement (Note 1)	8a ⇒ 9a, 7a1b ⇒ 7a2b, 6a2b ⇒ 7a2b, 5a3b ⇒ 5a4b, 4a4b ⇒ 5a4b
		Terminal Cover	Changed to Standard Equipment
		Terminal Screw Size	Identical (M3.5)
		Applicable Wire Size [ϕ mm, mm ²] (Bare Wire)	Equivalent
		Applicable Crimp Lug Size	Identical

Note 1. The table below shows the contact arrangement diagram.

[DC Operated]

Model Name		Item	New SR(D)-T Series Support for Structure/Rating
Existing (SRD-N Series) [Number of Contacts]	New (SRD-T Series) [Number of Contacts]		
SRD-N4 [4]	SRD-T5 [5]	Rating	Equivalent
		Rating (Coil)	Identical Range
		Coil Properties (Operating Time) [For Make Contacts]	ON Operation: 45 ms ⇒ 85 ms (24 VDC or Less), 60 ms (48 VDC or More) OFF Operation: 13 ms ⇒ 10 ms
		Coil Properties (Input)	Low Input (7W ⇒ 24 VDC or Less: 2.2W, 48 VDC or More: 3.3W)
		Coil (Polarity)	N/A ⇒ Available
		External Dimensions [H x W x D] (mm)	Equivalent (78 x 43 x 110 ⇒ 75 x 44 x 100)
		Mounting Dimension (Recommended mounting hole pitch)	Compatible
		Contact Arrangement (Note 1)	- ⇒ 5a, 4a ⇒ 4a1b, 3a1b ⇒ 3a2b, 2a2b ⇒ 3a2b
		Terminal Cover	Changed to Standard Equipment
		Terminal Screw Size	Identical (M3.5)
SRD-N5 [5]	SRD-T5 [5]	Applicable Wire Size [ϕ mm, mm ²] (Bare Wire)	Equivalent
		Applicable Crimp Lug Size	Identical
		Rating (Main Circuit)	Equivalent
		Rating (Coil)	Identical Range
		Coil Properties (Operating Time) [For Make Contacts]	ON Operation: 45 ms ⇒ 85 ms (24 VDC or Less), 60 ms (48 VDC or More) OFF Operation: 13 ms ⇒ 10 ms
		Coil Properties (Input)	Low Input (7W ⇒ 24 VDC or Less: 2.2W, 48 VDC or More: 3.3W)
		Coil (Polarity)	N/A ⇒ Available
		External Dimensions [H x W x D] (mm)	Smaller (78 x 53 x 110 ⇒ 75 x 44 x 100)
		Mounting Dimension (Recommended mounting hole pitch)	Not Compatible (Compatible with Adapter)
		Contact Arrangement (Note 1)	5a ⇒ 5a, 4a1b ⇒ 4a1b, 3a2b ⇒ 3a2b, 2a3b ⇒ -
SRD-N8 [8]	SRD-T9 [9]	Terminal Cover	Changed to Standard Equipment
		Terminal Screw Size	Identical (M3.5)
		Applicable Wire Size [ϕ mm, mm ²] (Bare Wire)	Equivalent
		Applicable Crimp Lug Size	Identical
		Rating (Main Circuit)	Equivalent
		Rating (Coil)	Identical Range
		Coil Properties (Operating Time) [For Make Contacts]	ON Operation: 45 ms ⇒ 85 ms (24 VDC or Less), 60 ms (48 VDC or More) OFF Operation: 13 ms ⇒ 10 ms
		Coil Properties (Input)	Low Input (7W ⇒ 24 VDC or Less: 2.2W, 48 VDC or More: 3.3W)
		Coil (Polarity)	N/A ⇒ Available
		External Dimensions [H x W x D] (mm)	Equivalent (78 x 43 x 138 ⇒ 75 x 44 x 130)
Mounting Dimension (Recommended mounting hole pitch)	Compatible		
Contact Arrangement (Note 1)	8a ⇒ 9a, 7a1b ⇒ 7a2b, 6a2b ⇒ 7a2b, 5a3b ⇒ 5a4b, 4a4b ⇒ 5a4b		
Terminal Cover	Changed to Standard Equipment		
Terminal Screw Size	Identical (M3.5)		
Applicable Wire Size [ϕ mm, mm ²] (Bare Wire)	Equivalent		
Applicable Crimp Lug Size	Identical		

Note 1. The table below shows the contact arrangement diagram.

[Mechanically Latched (AC Operated/DC Operated)]

Model Name		Item	New SR(D)-T Series Support for Structure/Rating
Existing (SRL(D)-N Series) [Number of Contacts]	New (SRL(D)-T Series) [Number of Contacts]		
SRL(D)-N4 [4]	SRL(D)-T5 [5]	Rating	Equivalent
		Rating (Coil)	Identical Range
		External Dimensions [H x W x D] (mm)	Equivalent (78 x 44 x 133.5 ⇒ 75 x 44 x 133.5)
		Mounting Dimension (Recommended mounting hole pitch)	Compatible
		Contact Arrangement (Note 1)	- ⇒ 5a, 4a ⇒ 4a1b, 3a1b ⇒ 3a2b, 2a2b ⇒ 3a2b
		Terminal Cover	Changed to Standard Equipment
		Terminal Screw Size	Identical (M3.5)
		Applicable Wire Size [φ mm, mm ²] (Bare Wire)	Equivalent
Applicable Crimp Lug Size	Identical		

Note 1. The table below shows the contact arrangement diagram.

New SR(D)-T Series		Existing SR(D)-N Series		
SR(L)(D)-T5	SR(D)-T9	SR(L)(D)-N4	SR(D)-N5	SR(D)-N8
5a	9a	4a	5a	8a
4a1b	7a2b	3a1b	4a1b	7a1b
3a2b	5a4b	2a2b	3a2b	6a2b
			2a3b	5a3b
				4a4b

2. New and Old Model Name Comparison Table

2.1 Magnetic Starters (Enclosed Type)

Type	Class AC-3 Rated Capacity (kW)		Auxiliary Contact (Standard)		MS-T Series		MS-N Series		
	200-220V	380 - 440V	MS-T	MS-N	Standard	Standard	Standard	Standard	
AC Operated	Non-Reversing	2.5	4	1a		MS-T10		MS-N10	
		3.5	5.5	1a1b	1a	MS-T12		MS-N11	
					1a1b		MS-N12		
		5.5	11	2a2b		MS-T21		MS-N20, MS-N21	
		11	18.5	2a2b		MS-T35		MS-N35	
		15	22	2a2b		MS-T50		MS-N50	
		18.5	30	2a2b		MS-T65		MS-N65	
	22	45	2a2b		MS-T80		MS-N80		
	30	55	2a2b		MS-T100		MS-N95		
	Reversing	5.5	11	2a2b x 2		MS-2xT21		MS-2xN20, MS-2xN21	
		11	18.5	2a2b x 2		MS-2xT35		MS-2xN35	
		15	22	2a2b x 2		MS-2xT50		MS-2xN50	
		18.5	30	2a2b x 2		MS-2xT65		MS-2xN65	
		22	45	2a2b x 2		MS-2xT80		MS-2xN80	
30		55	2a2b x 2		MS-2xT100		MS-2xN95		

2.2 Magnetic Starters (Open Type)

[AC Operated Type]

Type	Class AC-3 Rated Capacity (kW)		Auxiliary Contact (Standard)		MS-T Series		MS-N Series		
	200-220V	380 - 440V	MS-T	MS-N	Standard	With Fast Wiring Terminal	Standard	With CAN Terminal	
AC Operated	Non-Reversing	2.5	4	1a		MSO-T10	MSO-T10BC	MSO-N10	MSO-N10CX
		3.5	5.5	1a1b	1a	MSO-T12	MSO-T12BC	MSO-N11	MSO-N11CX
					1a1b			MSO-N12	MSO-N12CX
		4.5 (4:N20)	7.5	1a1b	-	MSO-T20	MSO-T20BC	MSO-N18	MSO-N18CX
		5.5	11	2a2b		MSO-T21	MSO-T21BC	MSO-N20	MSO-N20CX
		7.5	15	2a2b		MSO-T25	MSO-T25BC	MSO-N21	MSO-N21CX
		11	18.5	2a2b		MSO-T35	MSO-T35BC	MSO-N25	MSO-N25CX
		15	22	2a2b		MSO-T50	MSO-T50BC	MSO-N35	MSO-N35CX
		18.5	30	2a2b		MSO-T65	-	MSO-N50	-
		22	45	2a2b		MSO-T80	-	MSO-N65	-
	30	55	2a2b		MSO-T100	-	MSO-N80	-	
	Reversing	2.5	4	1a x 2 + 2b		MSO-2xT10	MSO-2xT10BC	MSO-2xN10	MSO-2xN10CX
		3.5	5.5	1a1b x 2 + 2b	1a x 2 + 2b	MSO-2xT12	MSO-2xT12BC	MSO-2xN11	MSO-2xN11CX
				1a1b x 2	2a2b x 2				
		4.5 (4:N20)	7.5	1a1b x 2		MSO-2xT20	MSO-2xT20BC	MSO-2xN18	MSO-2xN18CX
		5.5	11	2a2b x 2		MSO-2xT21	MSO-2xT21BC	MSO-2xN20	MSO-2xN20CX
		7.5	15	2a2b x 2		MSO-2xT25	MSO-2xT25BC	MSO-2xN21	MSO-2xN21CX
		11	18.5	2a2b x 2		MSO-2xT35	MSO-2xT35BC	MSO-2xN25	MSO-2xN25CX
		15	22	2a2b x 2		MSO-2xT50	MSO-2xT50BC	MSO-2xN35	MSO-2xN35CX
		18.5	30	2a2b x 2		MSO-2xT65	-	MSO-2xN50	-
22		45	2a2b x 2		MSO-2xT80	-	MSO-2xN65	-	
30	45	2a2b x 2		MSO-2xT100	-	MSO-2xN80	-		

[DC Operated Type]

Type	Class AC-3 Rated Capacity (kW)		Auxiliary Contact (Standard)		MS-T Series		MS-N Series		
	200-220V	380 - 440V	MS-T	MS-N	Standard	With Fast Wiring Terminal	Standard	With CAN Terminal	
DC Operated	Non-Reversing	3.5	5.5	1a1b	1a	MSOD-T12	MSOD-T12BC	MSOD-N11	MSOD-N11CX
		4.5	7.5		1a1b			1a1b	MSOD-N12
				5.5		11	2a2b		MSOD-T20
		11	18.5	2a2b		MSOD-T21	MSOD-T21BC	MSOD-N21	MSOD-N21CX
		15	22	2a2b		MSOD-T35	MSOD-T35BC	MSOD-N35	MSOD-N35CX
		18.5	30	2a2b		MSOD-T50	MSOD-T50BC	MSOD-N50	-
		22	45	2a2b		MSOD-T65	-	MSOD-N65	-
		30	55	2a2b		MSOD-T80	-	MSOD-N80	-
	30	55	2a2b		MSOD-T95	-	MSOD-N95	-	
	Reversing	3.5	5.5	1a1b x 2 + 2b	1a x 2 + 2b	MSOD-2xT12	MSOD-2xT12BC	MSOD-2xN11	MSOD-2xN11CX
		4.5	7.5	1a1b x 2 + 2b	-	MSOD-2xT20	MSOD-2xT20BC	-	-
		5.5	11	2a2b x 2		MSOD-2xT21	MSOD-2xT21BC	MSOD-2xN21	MSOD-2xN21CX
		11	18.5	2a2b x 2		MSOD-2xT35	MSOD-2xT35BC	MSOD-2xN35	MSOD-2xN35CX
		15	22	2a2b x 2		MSOD-2xT50	MSOD-2xT50BC	MSOD-2xN50	-
18.5		30	2a2b x 2		MSOD-2xT65	-	MSOD-2xN65	-	
22	45	2a2b x 2		MSOD-2xT80	-	MSOD-2xN80	-		
30	55	2a2b x 2		MSOD-2xT100	-	MSOD-2xN95	-		

2.3 Magnetic Contactors (Open Type)

[AC Operated Type]

(1) Comparison Under Rated Motor Load (Class AC-3)

Type	Class AC-3 Rated Operating Current (A)		Auxiliary Contact (Standard)		MS-T Series		MS-N Series		
	200-220V	380 - 440V	MS-T	MS-N	Standard	With Fast Wiring Terminal	Standard	With CAN Terminal	
AC Operated	Non-Reversing	11	9	1a		S-T10	S-T10BC	S-N10	S-N10CX
		13	12	1a1b	1a 1a1b	S-T12	S-T12BC	S-N11 S-N12	S-N11CX S-N12CX
		18 (20:N20)	18 (20:N20)	1a1b		S-T20	S-T20BC	S-N20	S-N20CX
		25	23	2a2b		S-T21	S-T21BC	S-N21	S-N21CX
		30	30	2a2b		S-T25	S-T25BC	S-N25	S-N25CX
		40	40	2a2b		S-T35	S-T35BC	S-N35	S-N35CX
		55	48	2a2b		S-T50	S-T50BC	S-N50	—
		65	65	2a2b		S-T65	—	S-N65	—
	85	85	2a2b		S-T80	—	S-N80	—	
	105	105	2a2b		S-T100	—	S-N95	—	
	Reversing	11	9	1a x 2 + 2b		S-2xT10	S-2xT10BC	S-2xN10	S-2xN10CX
		13	12	1a1b x 2 + 2b	1a x 2 + 2b	S-2xT12	S-2xT12BC	S-2xN11	S-2xN11CX
		18 (20:N20)	18 (20:N20)	1a1b x 2		S-2xT20	S-2xT20BC	S-2xN20	S-2xN20CX
		25	23	2a2b x 2		S-2xT21	S-2xT21BC	S-2xN21	S-2xN21CX
30		30	2a2b x 2		S-2xT25	S-2xT25BC	S-2xN25	S-2xN25CX	
40		40	2a2b x 2		S-2xT35	S-2xT35BC	S-2xN35	S-2xN35CX	
55		48	2a2b x 2		S-2xT50	S-2xT50BC	S-2xN50	—	
65		65	2a2b x 2		S-2xT65	—	S-2xN65	—	
Main Circuit 3-Pole	Non-Reversing	18	13	—		S-T32	S-T32BC	S-N18	S-N18CX
		26	17	—				S-N28	S-N28CX
		32	32	—				—	—
	Reversing	18	13	—		S-2xT32	S-2xT32BC	S-2xN18	S-2xN18CX
		26	17	2a2b x 2				S-2xN28	S-2xN28CX
		32	32	—				—	—

(2) Comparison Under Rated Resistance Load (Class AC-1)

Type	Class AC-1 Rated Operating Current (A)		Auxiliary Contact (Standard)		MS-T Series		MS-N Series		
	100 - 240V	380 - 440V	MS-T	MS-N	Standard	With Fast Wiring Terminal	Standard	With CAN Terminal	
AC Operated	Non-Reversing	20	11	1a		S-T10	S-T10BC	S-N10	S-N10CX
		20	13	1a1b	1a	S-T12	S-T12BC	S-N11	S-N11CX
		32	32	1a1b	—	S-T12, S-T20	S-T12BC, S-T20BC	S-N12	S-N12CX
				1a1b	—	—	—	S-N20	S-N20CX
		50	50	2a2b		S-T21, S-T25	S-T21BC, S-T25BC	S-N21	S-N21CX
		60	60	2a2b		S-T35	S-T35BC	S-N25	S-N25CX
		80	80	2a2b		S-T50	S-T50BC	S-N35	S-N35CX
		100	100	2a2b		S-T65	—	S-N50	—
	120	120	2a2b		S-T80	—	S-N65	—	
	135	135	2a2b		—	—	S-N80	—	
	150	150	2a2b		S-T100	—	S-N95	—	
	Reversing	20	11	1a x 2 + 2b		S-2xT10	S-2xT10BC	S-2xN10	S-2xN10CX
		20	13	1a1b x 2 + 2b	1a x 2	S-2xT12	S-2xT12BC	S-2xN11	S-2xN11CX
				1a1b x 2	—	S-2xT12, S-2xT20	S-2xT12BC, S-2xT20BC	—	—
32		32	1a1b x 2	—	—	—	S-2xN20	S-2xN20CX	
			2a2b x 2	—	S-2xT21, S-2xT25	S-2xT21BC, S-2xT25BC	S-2xN21	S-2xN21CX	
50		50	2a2b x 2		—	—	S-2xN25	S-2xN25CX	
60		60	2a2b x 2		S-2xT35	S-2xT35BC	S-2xN35	S-2xN35CX	
80		80	2a2b x 2		S-2xT50	S-2xT50BC	S-2xN50	—	
100	100	2a2b x 2		S-2xT65	—	S-2xN65	—		
Main Circuit 3-Pole	Non-Reversing	25	20	—		S-T32	S-T32BC	S-N18	S-N18CX
		30	30	—				S-N28	S-N28CX
		32	32	—				—	—
	Reversing	25	20	—		S-2xT32	S-2xT32BC	S-2xN18	S-2xN18CX
		30	30	2a2b x 2				S-2xN28	S-2xN28CX
		32	32	—				—	—

[DC Operated Type]

(3) Comparison Under Rated Motor Load (Class AC-3)

Type	Class AC-3 Rated Operating Current (A)		Auxiliary Contact (Standard)		MS-T Series		MS-N Series		
	200-220V	380 - 440V	MS-T	MS-N	Standard	With Fast Wiring Terminal	Standard	With CAN Terminal	
DC Operated	Non-Reversing	13	12	1a1b	1a 1a1b	SD-T12	SD-T12BC	SD-N11 SD-N12	SD-N11CX SD-N12CX
		18	18	1a1b		SD-T20	SD-T20BC	—	—
		25	23	2a2b		SD-T21	SD-T21BC	SD-N21	SD-N21CX
		40	40	2a2b		SD-T35	SD-T35BC	SD-N35	SD-N35CX
		55	48	2a2b		SD-T50	SD-T50BC	SD-N50	—
		65	65	2a2b		SD-T65	—	SD-N65	—
		85	85	2a2b		SD-T80	—	SD-N80	—
	105	105	2a2b		SD-T100	—	SD-N95	—	
	Reversing	13	12	1a1b x 2 + 2b	1a x 2 + 2b	SD-2xT12	SD-2xT12BC	SD-2xN11	SD-2xN11CX
		18	18	1a1b x 2		SD-2xT20	SD-2xT20BC	—	—
		25	23	2a2b x 2		SD-2xT21	SD-2xT21BC	SD-2xN21	SD-2xN21CX
		40	40	2a2b		SD-2xT35	SD-2xT35BC	SD-2xN35	SD-2xN35CX
		55	48	2a2b		SD-2xT50	SD-2xT50BC	SD-2xN50	—
		65	65	2a2b		SD-2xT65	—	SD-2xN65	—
85		85	2a2b		SD-2xT80	—	SD-2xN80	—	
105	105	2a2b		SD-2xT100	—	SD-2xN95	—		
Main Circuit 3-Pole	Non-Reversing	32	32	—		SD-T32	SD-T32BC	—	—
	Reversing	32	32	2a2b x 2		SD-2xT32	SD-2xT32BC	—	—

(4) Comparison Under Rated Resistance Load (Class AC-1)

Type	Class AC-1 Rated Operating Current (A)		Auxiliary Contact (Standard)		MS-T Series		MS-N Series		
	100 - 240V	380 - 440V	MS-T	MS-N	Standard	With Fast Wiring Terminal	Standard	With CAN Terminal	
DC Operated	Non-Reversing	20	13	1a1b	1a	SD-T12	SD-T12BC	SD-N11	SD-N11CX
		32	32	1a1b	—	SD-T12, SD-T20	SD-T12BC, SD-T20BC	SD-N12	SD-N12CX
		60	60	2a2b		SD-T21	SD-T21BC	SD-N21	SD-N21CX
		80	80	2a2b		SD-T35	SD-T35BC	SD-N35	SD-N35CX
		100	100	2a2b		SD-T50	SD-T50BC	SD-N50	—
		120	120	2a2b		SD-T65	—	SD-N65	—
		135	135	2a2b		SD-T80	—	—	—
		150	150	2a2b		—	—	SD-N80	—
	Reversing	20	13	1a1b x 2 + 2b	1a x 2 + 2b	SD-2xT12	SD-2xT12BC	SD-2xN11	SD-2xN11CX
		32	32	2a2b x 2		SD-2xT12 SD-2xT20	SD-2xT12BC SD-2xT20BC	—	—
		60	60	2a2b x 2		SD-2xT21	SD-2xT21BC	SD-2xN21	SD-2xN21CX
		80	80	2a2b x 2		SD-2xT35	SD-2xT35BC	SD-2xN35	SD-2xN35CX
		100	100	2a2b x 2		SD-2xT50	SD-2xT50BC	SD-2xN50	—
		120	120	2a2b x 2		SD-2xT65	—	SD-2xN65	—
135	135	2a2b x 2		SD-2xT80	—	—	—		
150	150	2a2b x 2		—	—	SD-2xN80	—		
Main Circuit 3-Pole	Non-Reversing	32	32	—		SD-T32	SD-T32BC	—	—
	Reversing	32	32	2a2b x 2		SD-2xT32	SD-2xT32BC	—	—

[Mechanically Latched (AC Operated/DC Operated)]

(5) Comparison Under Rated Motor Load (Class AC-3)

Type	Class AC-3 Rated Operating Current (A)		Auxiliary Contact (Valid)		MS-T Series		MS-N Series		
	200-220V	380 - 440V	MS-T	MS-N	Standard	With Fast Wiring Terminal	Standard	With CAN Terminal	
AC Operated	Non-Reversing	25	23	2a2b		SL-T21	SL-T21BC	SL-N21	SL-N21CX
		40	40	2a2b		SL-T35	SL-T35BC	SL-N35	SL-N35CX
		55	48	2a2b		SL-T50	SL-T50BC	SL-N50	—
		65	65	2a2b		SL-T65	—	SL-N65	—
		85	85	2a2b	1a2b	SL-T80	—	SL-N80	—
		105	105	1a2b		SL-T100	—	SL-N95	—
	Reversing	25	23	2a2b x 2		SL-2xT21	SL-2xT21BC	SL-2xN21	SL-2xN21CX
		40	40	2a2b x 2		SL-2xT35	SL-2xT35BC	SL-2xN35	SL-2xN35CX
		55	48	2a2b x 2		SL-2xT50	SL-2xT50BC	SL-2xN50	—
		65	65	2a2b x 2		SL-2xT65	—	SL-2xN65	—
		85	85	2a2b x 2	1a2b x 2	SL-2xT80	—	SL-2xN80	—
		105	105	1a2b x 2		SL-2xT100	—	SL-2xN95	—
DC Operated	Non-Reversing	25	23	2a2b		SLD-T21	SLD-T21BC	SLD-N21	SLD-N21CX
		40	40	2a2b		SLD-T35	SLD-T35BC	SLD-N35	SLD-N35CX
		55	48	2a2b		SLD-T50	SLD-T50BC	SLD-N50	—
		65	65	2a2b		SLD-T65	—	SLD-N65	—
		85	85	2a2b	1a2b	SLD-T80	—	SLD-N80	—
		105	105	2a2b		SLD-T95	—	SLD-N95	—
	Reversing	25	23	2a2b x 2		SLD-2xT21	SLD-2xT21BC	SLD-2xN21	SLD-2xN21CX
		40	40	2a2b		SLD-2xT35	SLD-2xT35BC	SLD-2xN35	SLD-2xN35CX
		55	48	2a2b		SLD-2xT50	SLD-2xT50BC	SLD-2xN50	—
		65	65	2a2b		SLD-2xT65	—	SLD-2xN65	—
		85	85	2a2b x 2	1a2b x 2	SLD-2xT80	—	SLD-2xN80	—
		105	105	2a2b		SLD-2xT100	—	SLD-2xN95	—

(6) Comparison Under Rated Resistance Load (Class AC-1)

Type	Class AC-1 Rated Operating Current (A)		Auxiliary Contact (Standard)		MS-T Series		MS-N Series		
	100 - 240V	380 - 440V	MS-T	MS-N	Standard	With Fast Wiring Terminal	Standard	With CAN Terminal	
AC Operated	Non-Reversing	32	32	2a2b		SL-T21	SL-T21BC	SL-N21	SL-N21CX
		60	60	2a2b		SL-T35	SL-T35BC	SL-N35	SL-N35CX
		80	80	2a2b		SL-T50	SL-T50BC	SL-N50	—
		100	100	2a2b		SL-T65	—	SL-N65	—
		120	120	2a2b	—	SL-T80	—	—	—
		135	135	—	1a2b	—	—	SL-N80	—
	Reversing	32	32	2a2b x 2		SL-2xT21	SL-2xT21BC	SL-2xN21	SL-2xN21CX
		60	60	2a2b x 2		SL-2xT35	SL-2xT35BC	SL-2xN35	SL-2xN35CX
		80	80	2a2b x 2		SL-2xT50	SL-2xT50BC	SL-2xN50	—
		100	100	2a2b x 2		SL-2xT65	—	SL-2xN65	—
		120	120	2a2b x 2	—	SL-2xT80	—	—	—
		135	135	—	1a2b x 2	—	—	SL-2xN80	—
DC Operated	Non-Reversing	32	32	2a2b		SLD-T21	SLD-T21BC	SLD-N21	SLD-N21CX
		60	60	2a2b		SLD-T35	SLD-T35BC	SLD-N35	SLD-N35CX
		80	80	2a2b		SLD-T50	SLD-T50BC	SLD-N50	—
		100	100	2a2b		SLD-T65	—	SLD-N65	—
		120	120	2a2b	—	SLD-T80	—	—	—
		135	135	—	1a2b	—	—	SLD-N80	—
	Reversing	32	32	2a2b x 2		SLD-2xT21	SLD-2xT21BC	SLD-2xN21	SLD-2xN21CX
		60	60	2a2b		SLD-2xT35	SLD-2xT35BC	SLD-2xN35	SLD-2xN35CX
		80	80	2a2b		SLD-2xT50	SLD-2xT50BC	SLD-2xN50	—
		100	100	2a2b		SLD-2xT65	—	SLD-2xN65	—
		120	120	2a2b x 2	—	SLD-2xT80	—	—	—
		135	135	—	1a2b x 2	—	—	SLD-2xN80	—
150	150	2a2b		SLD-2xT100	—	SLD-2xN95	—		

2.4 Thermal Overload Relays

Type	Heater Designation	TH-T Series		TH-N Series	
		Standard	With Fast Wiring Terminal	Standard	With CAN Terminal
Standard with 2-Element	0.12 - 11A	TH-T18	TH-T18BC	TH-N12	TH-N12CX
	1.3 - 15A			TH-N18	TH-N18CX
	0.24 - 15A	TH-T25	TH-T25BC	TH-N20	TH-N20CX
	22A			TH-N20TA	TH-N20TACX
	29A	TH-T50	TH-T50BC	TH-N20TA	TH-N20TACX
	35 - 42A	TH-T50	TH-T50BC	—	—
	15 - 54A	TH-T65	—	TH-N60	—
67 - 82A	TH-T100	—	TH-N60TA	—	
Overload/Constraint/ Open-Phase Protection (2E Type)	0.12 - 11A	TH-T18KP	TH-T18BCKP	TH-N12KP	TH-N12CXKP
	1.3 - 15A	TH-T25KP	TH-T25BCKP	TH-N18KP	TH-N18CXKP
	0.24 - 15A			TH-N20KP	TH-N20CXKP
	22A	TH-T50KP	TH-T50BCKP	TH-N20TAKP	TH-N20TACXKP
	29A	TH-T50KP	TH-T50BCKP	TH-N20TAKP	TH-N20TACXKP
	35 - 42A	TH-T50KP	TH-T50BCKP	—	—
	15 - 54A	TH-T65KP	—	TH-N60KP	—
67 - 82A	TH-T100KP	—	TH-N60TAKP	—	

2.5 Contactor Relays

[AC Operated Type]

Type	Contact Arrangement		T Series		N Series	
	T Series	N Series	Standard	With Fast Wiring Terminal	Standard	With CAN Terminal
AC Operated	5a, 4a1b, 3a2b	4a, 3a1b, 2a2b	SR-T5	SR-T5BC	SR-N4	SR-N4CX
		5a, 4a1b, 3a2b, 2a3b			SR-N5	SR-N5CX
	9a, 7a2b, 5a4b	8a, 7a1b, 6a2b, 5a3b, 4a4b	SR-T9	SR-T9BC	SR-N8	SR-N8CX

[DC Operated Type]

Type	Contact Arrangement		T Series		N Series	
	T Series	N Series	Standard	With Fast Wiring Terminal	Standard	With CAN Terminal
DC Operated	5a, 4a1b, 3a2b	4a, 3a1b, 2a2b	SRD-T5	SRD-T5BC	SRD-N4	SRD-N4CX
		5a, 4a1b, 3a2b, 2a3b			SRD-N5	SRD-N5CX
	9a, 7a2b, 5a4b	8a, 7a1b, 6a2b, 5a3b, 4a4b	SRD-T9	SRD-T9BC	SRD-N8	SRD-N8CX

[Mechanically Latched (AC Operated/DC Operated)]

Type	Contact Arrangement		T Series		N Series	
	T Series	N Series	Standard	With Fast Wiring Terminal	Standard	With CAN Terminal
AC Operated	5a, 4a1b, 3a2b	4a, 3a1b, 2a2b	SRL-T5	SRL-T5BC	SRL-N4	SRL-N4CX
DC Operated	5a, 4a1b, 3a2b	4a, 3a1b, 2a2b	SRLD-T5	SRLD-T5BC	SRLD-N4	SRLD-N4CX

3. Comparison of New and Old Coil Rating

3.1 Control Coil Types and Rating [AC Operation]

(1) Comparison of S-T10 - T50 Types, SR-T5/T9 Types and S-N10 - N35 Types, SR-N4 - N8 Types

New (For S-T10 - T50 Types, SR-T5/T9 Types)			Existing (For S-N10 - N35 Types, SR-N4 - N8 Types)		
Designation	Rated Voltage [V]		Designation	Rated Voltage [V]	
	50Hz	60Hz		50Hz	60Hz
24 VAC	24	24	24 VAC	24	24
48 VAC	48-50	48-50	48 VAC	48-50	48-50
100 VAC	100-127	100-127	100 VAC	100	100-110
			120 VAC	110-120	115-120
			127 VAC	125-127	127
200 VAC	200-240	200-240	200 VAC	200	200-220
			220 VAC	208-220	220
			230 VAC	220-240	230-240
300 VAC	260-300	260-300	260 VAC	240-260	260-280
400 VAC	380-440	380-440	380 VAC	346-380	380
			400 VAC	380-415	400-440
500 VAC	460-550	460-550	440 VAC	415-440	460-480
			500 VAC	500	500-550

Note 1. The new models have a wider rated voltage range.

Note 2. Rated voltage range for the coil designation 300 VAC for the new model S-T50 has been changed from that of the existing model S-N50. See item (3) below.

(2) Comparison of S-T10SA - T32SA Types, SR-T5SA/T9SA Types and S-N10SA - N28SA Types, SR-N4SA - N8SA Types

New (For S-T10 - T50SA Types, SR-T5/T9SA Types)				Existing (For S-N10 - N35SA Types, SR-N4 - N8SA Types)			
Designation	Rated Voltage [V]		Varistor Voltage	Designation	Rated Voltage [V]		Varistor Voltage
	50Hz	60Hz			50Hz	60Hz	
24 VAC	24	24	120V	24 VAC	24	24	120V
48 VAC	48-50	48-50		48 VAC	48-50	48-50	
100 VAC	100-127	100-127	470V	100 VAC	100	100-110	470V
				120 VAC	110-120	115-120	
				127 VAC	125-127	127	
200 VAC	200-240	200-220					
200 VAC	200-240	200-240		220 VAC	208-220	220	
				230 VAC	220-240	230-240	
300 VAC	260-300	260-300	910V	—	—	—	—
400 VAC	380-440	380-440		—	—	—	

Note 1. The new models have a wider rated voltage range.

Note 2. Coil designation 300 VAC/400 VAC has been added to the new model.

Note 3. S-T □ SA and SR-T □ SA are shipped with external coil surge absorber unit UT-SA21 for the control coil mounted.

(3) Comparison of S-T65 - T100 Types and S-N50 - N95 Types

New (S-T65 - T100 Types)		Existing (S-N50 - N95 Types)	
Designation	Rated Voltage	Designation	Rated Voltage
	50Hz/60Hz		50Hz/60Hz
24 VAC	24	24 VAC	24
48 VAC	48-50	48 VAC	48-50
100 VAC	100-127	100 VAC	100-127
200 VAC	200-240	200 VAC	200-240
300 VAC	260-350	300 VAC	260-350
400 VAC	380-440	400 VAC	380-440
500 VAC	460-550	500 VAC	460-550

Note 1. No changes to coil designation and rating range.

3.2 Control Coil Types and Rating [DC Operation]

(1) Comparison of SD-T12 - T100 Types, SRD-T5/T9 Types and SD-N11 - N95 Types, SRD-N4 - N8 Types

New (For SD-T12 - T100 Types, SRD-T5/T9 Types)		Existing (For SD-N11 - N95 Types, SRD-N4 - N8 Types)	
Designation	Rated Voltage	Designation	Rated Voltage
12 VDC	12 VDC	12 VDC	12 VDC
24 VDC	24 VDC	24 VDC	24 VDC
48 VDC	48 VDC	48 VDC	48 VDC
100 VDC	100 VDC	100 VDC	100 VDC
110 VDC	110 VDC	110 VDC	110 VDC
125 VDC	120 - 125 VDC	125 VDC	120 - 125 VDC
200 VDC	200 VDC	200 VDC	200 VDC
220 VDC	220 VDC	220 VDC	220 VDC

Note 1. No changes to coil designation and rating range.

Note 2. SD-T12 - T32 have coil polarity (A1(+), A2(-)).

(2) Comparison of SD-T12 - T50SA Types, SRD-T5/T9SA Types and SD-N11 - N35SA Types, SRD-N4 - N8SA Types

New (For SD-T12 - T50SA Types, SRD-T5/T9SA Types)			Existing (For SD-N11 - N35SA Types, SRD-N4 - N8SA Types)		
Designation	Rated Voltage	Varistor Voltage	Designation	Rated Voltage	Varistor Voltage
12 VDC	12 VDC	47V 	12 VDC	12 VDC	120V
24 VDC	24 VDC		24 VDC	24 VDC	
48 VDC	48 VDC		48 VDC	48 VDC	
100 VDC	100 VDC	470V	100 VDC	100 VDC	470V
110 VDC	110 VDC		110 VDC	110 VDC	
125 VDC	120 - 125 VDC		125 VDC	120 - 125 VDC	
200 VDC	200 VDC		200 VDC	200 VDC	
220 VDC	220 VDC		220 VDC	220 VDC	

Note 1. No changes to coil designation and rating range.

Note 2. New models have coil polarity (A1(+), A2(-)).

Note 3. New models have 12 VDC/24 VDC designation varistor voltage set lower.

Note 4. SD-T SA and SRD-T SA are shipped with external coil surge absorber unit UT-SA21 for the control coil mounted.

3.3 Control Coil Types and Rating [Mechanically Latched Type]

(1) Comparison of SL-T21 - T100 Types, SRL-T5 Type and SL-N21 - N95 Types, SRL-N4 Type

New (For SL-T21 - T100 Types, SRL-T5 Type)		Existing (For SL-N21 - N95 Types, SRL-N4 Type)	
Designation	Rated Voltage	Designation	Rated Voltage
24 VAC (Note 2)	24 VAC	24 VAC (Note 2)	24 VAC
48 VAC (Note 2)	48 - 50 VAC	48 VAC (Note 2)	48 - 50 VAC
100 VAC	100 - 127 VAC	100 VAC	100 - 127 VAC
200 VAC	200 - 240 VAC	200 VAC	200 - 240 VAC
300 VAC	260 - 350 VAC	300 VAC	260 - 350 VAC
400 VAC	380 - 440 VAC	400 VAC	380 - 440 VAC
500 VAC	460 - 550 VAC	500 VAC	460 - 550 VAC

Note 1. No changes to coil designation and rating range.

Note 2. 24 VAC and 48 VAC coils cannot be manufactured for SL-T100 and SL-N80/N95.

Note 3. 12 VAC coil can be manufactured for SL-T21, SRL-T5, SL-N21, and SRL-N4.

(2) Comparison of SLD-T21 - T100 Types, SRLD-T5 Type and SLD-N21 - N95 Types, SRLD-N4 Type

New (For SLD-T21 - T100 Types, SRLD-T5 Type)		Existing (For SLD-N21 - N95 Types, SRLD-N4 Type)	
Designation	Rated Voltage	Designation	Rated Voltage
12 VDC (Note 2)	12 VDC	12 VDC (Note 2)	12 VDC
24 VDC	24 VDC	24 VDC	24 VDC
48 VDC	48 VDC	48 VDC	48 VDC
100 VDC	100 - 110 VDC	100 VDC	100 - 110 VDC
125 VDC	120 - 125 VDC	125 VDC	120 - 125 VDC
200 VDC	200 - 220 VDC	200 VDC	200 - 220 VDC

Note 1. No changes to coil designation and rating range.

Note 2. 12 VDC coil cannot be manufactured for SLD-T100 and SLD-N80/N95.

Note 3. The coil has no polarity.

4. Changes to Product Marking

4.1 Terminal Number Display

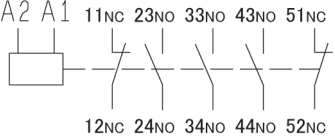
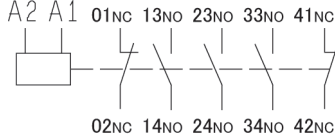
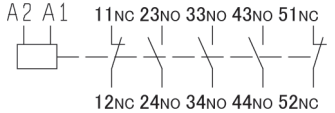
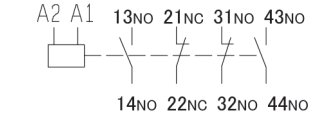
Item	MS-T Target Model Names (Typical Model)	New MS-T Series	Existing MS-N Series	Remarks	
Display Content	Main Terminal Number	S-T10 - T100 SD-T12 - T100 SL(D)-T21 - T100 TH-T18 - T100	Supply Side: 1/L1 3/L2 5/L3 Load Side: 2/T1 4/T2 6/T3	Supply Side: 1/L1 3/L2 5/L3 Load Side: 2/T1 4/T2 6/T3	
	Auxiliary Terminal Number (Magnetic Contactor)	S-T10, T12, T20 SD-T12, T20	Make Contacts: 13NO - 14NO Break Contacts: 21NC - 22NC	Make Contacts: 13NO - 14NO Break Contacts: 21NC - 22NC	NO (Normally Open): Make Contact NC (Normally Closed): Break Contact
		S-T21 - T35 SD-T21 - T35 SL(D)-T21 - T35	Make Contacts: 13NO-14NO 43NO-44NO Break Contacts: 21NC-22NC 31NC-32NC	Make Contacts: 13NO-14NO 43NO-44NO Break Contacts: 21NC-22NC 31NC-32NC	
		S-T50 - T100 SD-T50 - T100 SL(D)-T50 - T100	Make Contacts: 13NO-14NO 43NO-44NO Break Contacts: 21NC-22NC 31NC-32NC	Make Contacts: 13 (13) NO-14 (14) NO 43 (23) NO-44 (24) NO Break Contacts: 21 (31) NC-22 (32) NC 31 (41) NC-32 (42) NC	
	Auxiliary Terminal Number (Contactor Relay)	SR-T5 SRD-T5 SRL(D)-T5	<ul style="list-style-type: none"> Ones Place of the Number for Make Contacts: 3-4, Break Contacts: 1-2 Tens Place of the Number Changes to 1 - 5 E.g.: SR-T5 3a2b 	<ul style="list-style-type: none"> Ones Place of the Number for Make Contacts: 3-4, Break Contacts: 1-2 Tens Place of the Number Changes to 0 - 4 E.g.: SR-N5 3a2b 	Complies With the International Standards IEC
		SR-T9 SRD-T9	<ul style="list-style-type: none"> Ones Place of the Number for Make Contacts: 3-4, Break Contacts: 1-2 Tens Place of the Number Changes to 1 - 9 E.g.: SR-T9 5a4b 	<ul style="list-style-type: none"> Ones Place of the Number for Make Contacts: 3-4, Break Contacts: 1-2 Tens Place of the Number Changes to 1 - 8 E.g.: SR-N8 5a3b 	
Coil Terminal Number	S-T10 - T35 SD-T12 - T35 SL(D)-T21 - T35	A1, A2 (Embossed Characters)	A1, A2 (Simultaneous Printing With Rated Coil Display)		
	S-T50 - T100 SD-T50 - T100 SL(D)-T50 - T100	A1, A2 (Embossed Characters)	A1, A2 (Embossed Characters)		
	SL(D)-T21/T35 SL(D)-T100 SRL(D)-T5	E1, E2 (printed in black on white nameplates)	E1, E2 (printed in black on white nameplates)		
	SL(D)-T50	E1, E2 (printed in black on white nameplates)	E1, E2 (Embossed Characters)		
	SL(D)-T50FN/T65	E1, E2 (Embossed Characters)	E1, E2 (Embossed Characters)		
	SL(D)-T80	E1, E2 (Embossed Characters)	E1, E2 (printed in black on white nameplates)		

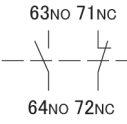
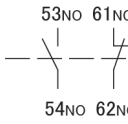
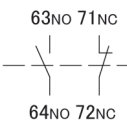
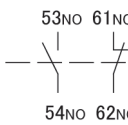
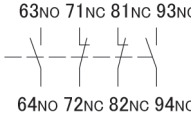
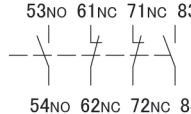
Item	MS-T Target Model Names (Typical Model)	New MS-T Series	Existing MS-N Series	Remarks
Display Content	Auxiliary Terminal Number (Auxiliary Contact Unit)	UT-AX11 · Ones Place of the Number for Make Contacts: 3-4 Break Contacts: 1-2 · Tens Place of the Number Changes to 6 - 7 Example: UT-AX11 1a1b (When mounted on the left side of the body) 	· Ones Place of the Number for Make Contacts: 3-4, Break Contacts: 1-2 · Tens Place of the Number Changes to 5 - 6 Example: UN-AX11 1a1b (When mounted on the left side of the body) 	
		UT-AX2 · Ones Place of the Number for Make Contacts: 3-4, Break Contacts: 1-2 · Tens Place of the Number Changes to 6 - 7 E.g.: UT-AX2 1a1b 	· Ones Place of the Number for Make Contacts: 3-4, Break Contacts: 1-2 · Tens Place of the Number Changes to 5 - 6 E.g.: UN-AX2 1a1b 	
		UT-AX4 · Ones Place of the Number for Make Contacts: 3-4, Break Contacts: 1-2 · Tens Place of the Number Changes to 6 - 9 E.g.: UT-AX4 2a2b 	· Ones Place of the Number for Make Contacts: 3-4, Break Contacts: 1-2 · Tens Place of the Number Changes to 5 - 8 E.g.: UN-AX4 2a2b 	
Display Position	Terminal Number	S-T10 - T20 SD-T12 - T20 SR-T5/T9 SRD-T5/T9 UT-AX2, AX4 · Laser printed on the product front for both the body and auxiliary contact unit	· On the body (lower part of SR-N8), it is printed on the product front in blue · On the upper part of SR-N8 (auxiliary contact unit), the terminal number is printed on the paper name plate in blue	
		UT-AX11 · The terminal number is printed on a paper name plate on the product front	· The terminal number is printed on the paper name plate in blue	
		S-T21 - T35 SD-T21 - T35 SL(D)-T21 - T35 SRL(D)-T5 · Laser printed on the front of the product	· Printed on the front of the product in blue	
		S-T50 SD-T50 · Laser printed on the front of the product	· Printed on the name plate on the product front in blue	
		S-T65 - T100 SD-T65 - T100 SL(D)-T100 · Printed on the name plate on the product front in gray	· Printed on the name plate on the product front in blue	
		SL(D)-T50 · Laser printed on the front of the product	· Embossed characters on the top surface of the product	
		SL(D)-T50FN/T65 · Embossed characters on the top surface of the product	· Embossed characters on the top surface of the product	
		SL(D)-T80 · Embossed characters on the top surface of the product	· Printed on the name plate on the product front in blue	

4.2. Rating Display

Item	MS-T Target Model Names (Typical Model)	MS-T Series	MS-N Series	Remarks	
Display Method	Main Circuit Rating	S-T10 - T35 SD-T12 - T35 SR-T5, T9 SRD-T5, T9 SL(D)-T21/T35 SRL(D)-T5	All laser printed on the side	<ul style="list-style-type: none"> The AC1=Ith rating (A) is printed on the front bottom left Other ratings are displayed on a name plate on the side 	
		S-T50 SD-T50 SL(D)-T50	Laser printed on the side	Printed on the name plate on the front in gray	
		S-T65 - T100 SD-T65 - T100	Printed on the name plate on the front in gray	Printed on the name plate on the front in gray	
		SL(D)-T50FN/T65/T80	Laser printed on the front	Printed on the name plate on the front in gray	
		SL(D)-T100	Printed on the name plate on the front in gray	Printed on the name plate on the front in gray	
	Coil Rating	S-T10 - T35 SD-T12 - T35 SR-T5, T9 SRD-T5, T9 SL(D)-T21 - T35 SRL(D)-T5	<ul style="list-style-type: none"> Laser printed for S and SD (No color-coding) SL(D): Laser printed on closing coil Printed in black on white on tripping coil 	<ul style="list-style-type: none"> The designation 100 VAC/200 VAC has all rated ranges color-coded (between the power supply side coil terminals) 100V 50Hz 100-110V 60Hz 200V 50Hz Other ratings have all rated ranges printed on a name plate in white SD and SRD are printed in black on blue SL(D) is printed in black on green 	
		S-T50 SD-T50	All laser printed (No color-coding)	<ul style="list-style-type: none"> The designation 100 VAC / 200 VAC are printed in black on color-coded nameplates Other ratings are printed in black on white nameplates SD is printed in black on blue SL(D) is printed in black on green 	
		S-T65 - T100 SD-T65 - T100 SL(D)-T65 - T100 SL(D)-T50FN	All are printed in black on white nameplates		
	Coil Polarity (+ -)	SD-T12 - T32 SRD-T5, T9	Laser printed between the coil terminals (E.g.) 	- (no marking as it has no polarity)	











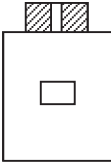
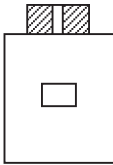

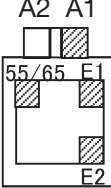

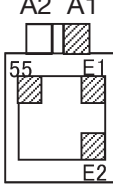

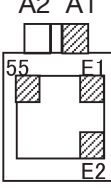

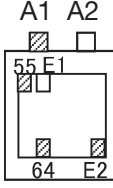

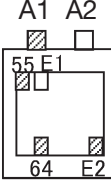
4.3 Model Name Display

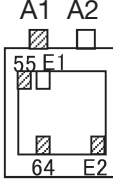
Item	MS-T Target Model Names (Typical Model)	MS-T Series	MS-N Series	Remarks
Display Method	Model Name	S-T10 - T35 SD-T12 - T35 SR-T5, T9 SRD-T5, T9 UT-AX2, AX4	Laser printed on the product front left (Display up to 3rd symbol)	Printed on the front left center of the product in blue
		S-T50 SD-T50	Laser printed on the product front left (Display up to 3rd symbol)	Printed on the name plate on the product front in blue
		S-T65 - T100 SD-T65 - T100	Printed on the name plate on the product front in gray (Display up to 3rd symbol)	Printed on the name plate on the product front in blue
		UT-AX11	Printed on the paper name plate on the side of the product	Printed on the front center of the product in blue
		SL(D)-T21 - T50 SRL(D)-T5	Printed on the front center of the product in black	Printed on the front center of the product in blue
		SL(D)-T65 - T80 SL(D)-T50FN	Laser printed on the product front left	Printed on the front right of the product in blue
		SL(D)-T100	Printed on the name plate on the product front in gray	Printed on the name plate on the product front in blue

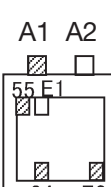
Note: From MS-T series magnetic starters (model name: MSO-T□), the model name sticker is applied to the side of the magnetic contactor.

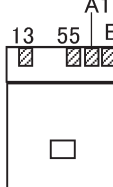
5. Differences Related to Wiring/Handling

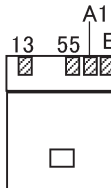
5.1 Terminals/Location

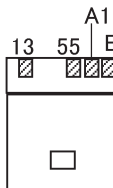
Item	MS-T Target Model Names (Typical Model)	MS-T Series	MS-N Series	Remarks										
Coil Terminal Location	S-T10 - T100 SD-T12 - T100 SR(D)-T5/T9	2 Terminals Located on the Power Supply Side A1/A2 A1/A2 	2 Terminals Located on the Power Supply Side A1/A2 A1/A2 											
	SL(D)-T21 - T35 SRL(D)-T5	 are wiring terminals A2 A1 	 are wiring terminals A2 A1 											
	SL(D)-T50	 are wiring terminals A2 A1 	 are wiring terminals A1 A2 	Rewire terminals as shown below when performing replacement. <table border="1" data-bbox="1177 972 1426 1088"> <thead> <tr> <th>T Series Terminal</th> <th>N Series Terminal</th> </tr> </thead> <tbody> <tr> <td>A1</td> <td>A1</td> </tr> <tr> <td>55</td> <td>55</td> </tr> <tr> <td>E2</td> <td>E2</td> </tr> <tr> <td>E1</td> <td>64</td> </tr> </tbody> </table>	T Series Terminal	N Series Terminal	A1	A1	55	55	E2	E2	E1	64
	T Series Terminal	N Series Terminal												
	A1	A1												
	55	55												
	E2	E2												
E1	64													
SL(D)-T65 SL(D)-T50FN	 are wiring terminals A1 A2 	 are wiring terminals A1 A2 												
SL(D)-T80	 are wiring terminals A1 A2 	 are wiring terminals A1 	Rewire terminals as shown below when performing replacement. <table border="1" data-bbox="1177 1462 1426 1579"> <thead> <tr> <th>T Series Terminal</th> <th>N Series Terminal</th> </tr> </thead> <tbody> <tr> <td>A1</td> <td>A1</td> </tr> <tr> <td>55</td> <td>55</td> </tr> <tr> <td>E2</td> <td>E2</td> </tr> <tr> <td>64</td> <td>13</td> </tr> </tbody> </table>	T Series Terminal	N Series Terminal	A1	A1	55	55	E2	E2	64	13	
T Series Terminal	N Series Terminal													
A1	A1													
55	55													
E2	E2													
64	13													
SL(D)-T100	 are wiring terminals A1 	 are wiring terminals A1 												

Item	MS-T Target Model Names (Typical Model)	MS-T Series		MS-N Series		Remarks
Contact Mark Display of Auxiliary Terminal (Displayed with engraved marks on contact and terminal, etc.)	S-T10 - T35 SD-T12 - T35 SL(D)-T21 - T35 SR-T5, SRD-T5 SRL(D)-T5	Make Contact ▽	Break Contact △	Make Contact ⊥ ⊥	Break Contact ≠	
	SR-T9, SRD-T9	Lower Part (Body Side) Make Contact ▽ Break Contact △	Upper Part (Auxiliary Contact Unit Side) Make Contact ▽ Break Contact △	Lower Part (Body Side) Make Contact ⊥ ⊥ Break Contact ≠	Upper Part (Auxiliary Contact Unit Side) Make Contact ▽ Break Contact △	

5.2 Rail Mounting

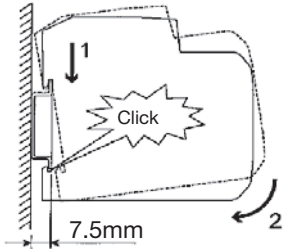
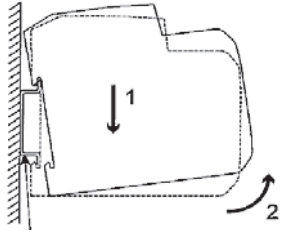
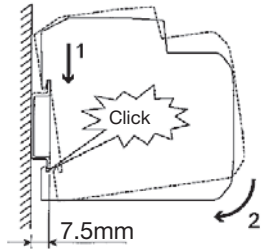
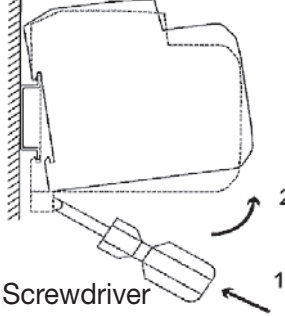
Item	MS-T Target Model Names (Typical Model)	MS-T Series		MS-N Series		Remarks
DIN Rail Mounting	S-T10 - T25 SD-T12 - T21 SL(D)-T21	· Mounting 	· Removal 	· Mounting 	· Removal 	
	S-T35 - T65 SD-T35 SL(D)-T35 - T65	Same Operation as N Series		Operated by Screwdriver		
	S-T80 SD-T50 SL(D)-T80	Same Operation as N Series		Not Available		

6. Application of Thermal Overload Relays and Optional Units

6.1 Combining with Thermal Overload Relays and Optional Units

(1) S(D)-(2X)T10 - T50 Types

Model Name	Thermal Overload Relays		For Magnetic Starters		Additional Auxiliary Contact Units		Mechanical Interlock Units		Surge Absorber Units for Control Coils (External)			Coil Surge Absorber Mounted Product (SA)			Coil DC/AC Interfaces			Reversing Connecting Conductor Units							
	TH-T18	TH-T25	TH-T50	UN-TH21	UT-TH50	UT-AX4	UT-AX2	UT-AX11	UT-ML11	UT-ML20	UN-ML21	UT-SA21	UT-SA22	UT-SA23	UT-SA25	UT-SA320	UT-SA332	UT-SA332	UT-SY21	UT-SY22	UT-SD10	UT-SD20	UT-SD25	UN-SD18CX	UN-SD25CX
S-T10	○	-	-	-	○	○	○	○	-	-	-	○	○	○	○	○	○	○	○	○	○	-	-	-	-
S-T12	○	-	-	-	○	○	○	○	-	-	-	○	○	○	○	○	○	○	○	○	○	-	-	-	-
S-T20	○	-	-	-	○	○	○	○	-	-	-	○	○	○	○	○	○	○	○	○	○	-	-	-	-
S-T21	-	○	-	○	○	○	○	○	-	-	-	○	○	○	○	○	○	○	○	○	○	-	-	-	-
S-T25	-	○	-	○	○	○	○	○	-	-	-	○	○	○	○	○	○	○	○	○	○	-	-	-	-
S-T32	-	-	-	-	○	○	○	○	-	-	-	○	○	○	○	○	○	○	○	○	○	-	-	-	-
S-T35	-	○	○	-	○	○	○	○	-	-	-	○	○	○	○	○	○	○	○	○	○	-	-	-	-
S-T50	-	○	○	-	○	○	○	○	-	-	-	○	○	○	○	○	○	○	○	○	○	-	-	-	-
S-2xT10	○	-	-	-	○	○	○	○	■	-	-	○	○	○	○	○	○	○	○	○	○	-	-	-	-
S-2xT12	○	-	-	-	○	○	○	○	■	-	-	○	○	○	○	○	○	○	○	○	○	-	-	-	-
S-2xT20	○	-	-	-	○	○	○	○	■	-	-	○	○	○	○	○	○	○	○	○	○	-	-	-	-
S-2xT21	-	○	-	○	○	○	○	○	-	-	■	○	○	○	○	○	○	○	○	○	○	-	-	-	-
S-2xT25	-	○	-	○	○	○	○	○	-	-	■	○	○	○	○	○	○	○	○	○	○	-	-	-	-
S-2xT32	-	-	-	-	○	■	-	-	-	-	■	○	○	○	○	○	○	○	○	○	○	-	-	-	-
S-2xT35	-	○	○	-	○	○	○	○	-	-	■	○	○	○	○	○	○	○	○	○	○	-	-	-	-
S-2xT50	-	○	○	-	○	○	○	○	-	-	■	○	○	○	○	○	○	○	○	○	○	-	-	-	-
SD-T10	○	-	-	-	○	○	○	○	-	○	-	○	○	○	○	○	○	○	○	○	○	-	-	-	-
SD-T20	○	-	-	-	○	○	○	○	-	○	-	○	○	○	○	○	○	○	○	○	○	-	-	-	-
SD-T32	-	○	-	○	○	○	○	○	-	○	-	○	○	○	○	○	○	○	○	○	○	-	-	-	-
SD-T35	-	○	-	○	○	○	○	○	-	○	-	○	○	○	○	○	○	○	○	○	○	-	-	-	-
SD-T50	-	○	-	○	○	○	○	○	-	○	-	○	○	○	○	○	○	○	○	○	○	-	-	-	-
SD-2xT12	○	-	-	-	○	○	○	○	■	-	-	○	○	○	○	○	○	○	○	○	○	-	-	-	-
SD-2xT20	○	-	-	-	○	○	○	○	■	-	-	○	○	○	○	○	○	○	○	○	○	-	-	-	-
SD-2xT21	-	○	-	○	○	○	○	○	-	■	-	○	○	○	○	○	○	○	○	○	○	-	-	-	-
SD-2xT32	-	-	-	-	○	■	-	-	-	■	-	○	○	○	○	○	○	○	○	○	○	-	-	-	-
SD-2xT35	-	○	-	○	○	○	○	○	-	■	-	○	○	○	○	○	○	○	○	○	○	-	-	-	-
SD-2xT50	-	○	-	○	○	○	○	○	-	■	-	○	○	○	○	○	○	○	○	○	○	-	-	-	-

(2) S(D)-(2X)T65 - T100 Types

Model Name	Thermal Overload Relays		Additional Auxiliary Contact Units		Mechanical Interlock Units		Surge Absorber Units for Control Coils (External)			Coil DC/AC Interfaces			Reversing Connecting Conductor Units			Live Part Protection Covers			Terminal Cover						
	TH-T65	TH-T100	UN-AX4	UN-AX2	UN-AX80	UN-ML21	UN-ML80	UN-SA721	UN-SA725	UN-SY31	UN-SY32	UN-SY11	UN-SY12	UN-SD50	UN-SD80	UN-CZ500	UN-CZ502	UN-CZ800	UN-CZ802	UT-CW800					
S-T65	○	-	○	○	-	○	-	-	-	○	○	○	○	○	○	○	○	○	○	○	○	-	-	-	-
S-T80	○	○	-	○	-	○	-	-	-	-	-	-	-	-	-	-	-	-	-	-	-	-	-	-	-
S-T100	○	○	-	○	-	○	-	-	-	-	-	-	-	-	-	-	-	-	-	-	-	-	-	-	-
S-2xT65	○	-	○	○	-	○	-	-	-	-	-	-	-	-	-	-	-	-	-	-	-	-	-	-	-
S-2xT80	○	○	-	○	-	○	-	-	-	-	-	-	-	-	-	-	-	-	-	-	-	-	-	-	-
S-2xT100	○	○	-	○	-	○	-	-	-	-	-	-	-	-	-	-	-	-	-	-	-	-	-	-	-
SD-T65	○	-	○	○	-	○	-	-	-	-	-	-	-	-	-	-	-	-	-	-	-	-	-	-	-
SD-T80	○	○	-	○	-	○	-	-	-	-	-	-	-	-	-	-	-	-	-	-	-	-	-	-	-
SD-T100	○	○	-	○	-	○	-	-	-	-	-	-	-	-	-	-	-	-	-	-	-	-	-	-	-
SD-2xT65	○	-	○	○	-	○	-	-	-	-	-	-	-	-	-	-	-	-	-	-	-	-	-	-	-
SD-2xT80	○	○	-	○	-	○	-	-	-	-	-	-	-	-	-	-	-	-	-	-	-	-	-	-	-
SD-2xT100	○	○	-	○	-	○	-	-	-	-	-	-	-	-	-	-	-	-	-	-	-	-	-	-	-

Note 1. ○ : Applicable -; Not Applicable ■ : Standard Combination Product

Note 2. ■ indicates dedicated thermal overload relays and optional units for MS-T series.

Note 3. UT-AX4/UT-AX2 and UT-AX11 cannot be mounted for usage at the same time.

(3) SL(D)-(2X)T21 - T50 Types

Model Name	Thermal Overload Relays		Connecting Conductor Kit for Magnetic Starters		Additional Auxiliary Contact Units		Mechanical Interlock Units	Surge Absorber Units for Control Coils (Closing Coil)				Surge Absorber Units for Control Coils (Tripping Coil)				Reversing Connecting Conductor Units		3-Pole Array Connection Units		
	TH-T25	TH-T50	UN-TH21	UT-TH50 /AX2	UT-AX4 /AX2	UN-ML21		UT-SA21	UT-SA22	UT-SA13	UT-SA23	UT-SA25	UN-SA721	UN-SA712	UN-SA713	UN-SA723	UN-SA725	UT-SD25	UN-SD25CX	UN-YY21
SL-T21	○	-	○	-	○	○	○	○	○	○	○	○	○	○	○	○	○	○	○	-
SL-T35	○	○	-	○	○	○	○	○	○	○	○	○	○	○	○	○	○	○	○	○
SL-T50	○	○	-	○	○	○	○	○	○	○	○	○	○	○	○	○	○	○	○	○
SL-2xT21	○	-	○	-	○	■	○	○	○	○	○	○	○	○	○	○	○	○	○	-
SL-2xT35	○	○	-	○	○	■	○	○	○	○	○	○	○	○	○	○	○	○	○	-
SL-2xT50	○	○	-	○	○	■	○	○	○	○	○	○	○	○	○	○	○	○	○	-
SLD-T21	○	-	○	-	○	○	○	○	○	○	○	○	○	○	○	○	○	○	○	-
SLD-T35	○	○	-	○	○	○	○	○	○	○	○	○	○	○	○	○	○	○	○	-
SLD-T50	○	○	-	○	○	○	○	○	○	○	○	○	○	○	○	○	○	○	○	-
SLD-2xT21	○	-	○	-	○	■	○	○	○	○	○	○	○	○	○	○	○	○	○	-
SLD-2xT35	○	○	-	○	○	■	○	○	○	○	○	○	○	○	○	○	○	○	○	-
SLD-2xT50	○	○	-	○	○	■	○	○	○	○	○	○	○	○	○	○	○	○	○	-

(4) SL(D)-(2X)T65 - T100 Types

Model Name	Thermal Overload Relays		Additional Auxiliary Contact Units		Mechanical Interlock Units		Surge Absorber Units for Control Coils (Tripping Coil)				Reversing Connecting Conductor Units				Live Part Protection Covers				Terminal Cover				
	TH-T65	TH-T100	UN-AX4 /AX2	UN-AX11	UN-AX80	UN-ML21	UN-ML50	UN-SA721	UN-SA722	UN-SA713	UN-SA723	UN-SA725	UN-SD50	UN-SD80	UN-CZ500	UN-CZ502	UN-CZ800	UN-CZ802	UN-CZ506	UN-CZ806	UN-UT- CW800	UN-YY50	UN-YY80
SL-T65	○	-	-	○	-	○	-	○	○	○	○	○	○	-	○	○	○	○	○	○	○	○	-
SL-T80	○	○	-	○	-	○	-	○	○	○	○	○	○	-	○	○	○	○	○	○	○	○	-
SL-T100	○	○	-	○	-	○	-	○	○	○	○	○	○	-	○	○	○	○	○	○	○	○	-
SL-2xT65	○	-	-	○	-	■	-	○	○	○	○	○	○	-	○	○	○	○	○	○	○	○	-
SL-2xT80	○	○	-	○	-	■	-	○	○	○	○	○	○	-	○	○	○	○	○	○	○	○	-
SL-2xT100	○	○	-	○	-	○	-	○	○	○	○	○	○	-	○	○	○	○	○	○	○	○	-
SLD-T65	○	-	-	○	-	○	-	○	○	○	○	○	○	-	○	○	○	○	○	○	○	○	-
SLD-T80	○	○	-	○	-	○	-	○	○	○	○	○	○	-	○	○	○	○	○	○	○	○	-
SLD-T100	○	○	-	○	-	○	-	○	○	○	○	○	○	-	○	○	○	○	○	○	○	○	-
SLD-2xT65	○	-	-	○	-	■	-	○	○	○	○	○	○	-	○	○	○	○	○	○	○	○	-
SLD-2xT80	○	○	-	○	-	■	-	○	○	○	○	○	○	-	○	○	○	○	○	○	○	○	-
SLD-2xT100	○	○	-	○	-	○	-	○	○	○	○	○	○	-	○	○	○	○	○	○	○	○	-

Note 1. ○ : Applicable -; Not Applicable ■ : Standard Combination Product

Note 2. ■ indicates dedicated thermal overload relays and optional units for MS-T series.

6.2 Optional Units for Thermal Overload Relays

Model Name	Independent Mounting Units		Connecting Conductor Kits for MSO		Fluorescent Display Lamps for Thermal Overload Relays		Reset Releases for Thermal Overload Relays		Live Part Protection Covers/Terminal Cover		
	UT-HZ18	UN-RM20	UN-TH21	UT-TH50	UN-TL12	UN-TL20	UN-TL60	UT-RR	UN-RR	UN-CZ605	UT-CW655
TH-T18	○	-	- (Not Required)	- (Not Required)	○	-	-	○	-	- (Not Required)	- (Not Required)
TH-T25	-	○	○	○	-	-	-	-	-	- (Not Required)	- (Not Required)
TH-T50	-	-	-	○	-	-	-	-	-	- (Not Required)	- (Not Required)
TH-T65	-	-	-	-	-	○	-	-	-	- (Not Required)	- (Not Required)
TH-T100	-	-	-	-	-	-	○	-	-	○	-

Note 1. ○ : Applicable - : Not Applicable

Note 2. ■ indicates dedicated optional units for MS-T series.

6.3 Compatibility of New and Old Thermal Overload Relays and Magnetic Contactors When Used In Combination

Model Name	Thermal Overload Relays				Thermal Overload Relays					
	TH-T18	TH-T25	TH-T50	TH-T65	TH-N12	TH-N18	TH-N20	TH-N20TA	TH-N60	TH-N60TA
S-N10	-	-	-	-	-	-	-	-	-	-
S-N11	-	-	-	-	-	-	-	-	-	-
S-N12	-	-	-	-	-	-	-	-	-	-
S-N20	-	-	-	-	-	-	-	-	-	-
S-N21	-	-	-	-	-	-	-	-	-	-
S-N25	-	-	-	-	-	-	-	-	-	-
S-N35	-	-	-	-	-	-	-	-	-	-
S-N50	-	-	-	○	-	-	-	-	○	-
S-N65	-	-	-	○	-	-	-	-	○	○
S-N80	-	-	-	○	-	-	-	-	○	○
S-N95	-	-	-	○	-	-	-	-	-	-
SD-N11	-	-	-	-	-	-	-	-	-	-
SD-N12	-	-	-	-	-	-	-	-	-	-
SD-N21	-	-	-	-	-	-	-	-	-	-
SD-N35	-	-	-	-	-	-	-	-	-	-
SD-N50	-	-	-	○	-	-	-	-	○	-
SD-N65	-	-	-	○	-	-	-	-	○	○
SD-N80	-	-	-	○	-	-	-	-	○	○
SD-N95	-	-	-	○	-	-	-	-	-	-
SL(D)-N21	-	-	-	-	-	-	-	-	-	-
SL(D)-N35	-	-	-	-	-	-	-	-	-	-
SL(D)-N50	-	-	-	○	-	-	-	-	○	-
SL(D)-N65	-	-	-	○	-	-	-	-	○	○
SL(D)-N80	-	-	-	○	-	-	-	-	○	○
SL(D)-N95	-	-	-	○	-	-	-	-	-	-
SL(D)-T100	-	-	-	-	-	-	-	-	-	-

Note 1. ○ : Applicable - : Not Applicable

7. Domestic and International Standards

7.1 Regulations/Standards Conformance

Model		MS-T Series							MS-N Series						
		Model Name	Conformity and Compliance		CE Marking	Certified			Model Name	Conformity and Compliance		CE Marking	Certified		
			JIS	IEC		UL	CCC	TUV		JIS	IEC		UL	CCC	TUV
Magnetic Contactors	Non-Reversing	S-T10 - T100 SD-T12 - T100	○	○	○	◎	◎	◎	S-N10 - N95 SD-N11 - N95	○	○	○	◎	◎	◎
	Reversing	S-2XT10 - 2XT100 SD-2XT12 - 2XT100	○	○	○	◎	◎	-	S-2XN10 - 2XN95 SD-2XN11 - 2XN95	○	○	○	◎	◎	-
Open Type Magnetic Starters	Non-Reversing/2-Element	MSO-T10 - T100 MSOD-T12 - T100	○	○	*	*	* ^{Note 3}	*	MSO-N10 - N95 MSOD-N11 - N95	○	○	*	*	◎	*
	Non-Reversing/3-Element	MSO-T10 - T100KP MSOD-T12 - T100KP	○	○	Note 2 -	Note 2 -	◎	Note 2 -	MSO-N10 - N95KP MSOD-N11 - N95KP	○	○	Note 2 -	◎	◎	Note 2 -
	Reversing/2-Element	MSO-2XT10 - 2XT100 MSOD-2XT12 - 2XT100	○	○	*	*	* ^{Note 3}	*	MSO-2XN10 - 2XN95 MSOD-2XN11 - 2XN95	○	○	*	*	◎	*
	Reversing/3-Element	MSO-2XT10 - 2XT100KP MSOD-2XT12 - 2XT100KP	○	○	Note 2 -	Note 2 -	◎	Note 2 -	MSO-2XN10 - 2XN95KP MSOD-2XN11 - 2XN95KP	○	○	Note 2 -	☆	◎	Note 2 -
Enclosed Type Magnetic Starters	Non-Reversing/2-Element	MS-T10 - T100	○	○	-	-	-	-	MS-N10 - N95	○	○	-	-	◎	-
	Non-Reversing/3-Element	MS-T10 - T100KP	○	○	-	-	-	-	MS-N10 - N95KP	○	○	-	-	◎	-
Mechanically Latched Contactors	Non-Reversing	SL(D)-T21 - T100	○	○	-	☆	◎	-	SL(D)-N21 - N95	○	○	-	☆	◎	-
	Reversing	SL(D)-2XT21 - 2XT100	○	○	-	☆	◎	-	SL(D)-2XN21 - 2XN95	○	○	-	☆	◎	-
Thermal Overload Relays	2-Element	TH-T18 - T100	○	○	*	*	* ^{Note 3}	*	TH-N12 - N60TA	○	○	*	*	◎	*
	3-Element	TH-T18 - T100KP	○	○	○	◎	◎	◎	TH-N12 - N60TAKP	○	○	○	◎	◎	◎
Contactor Relays	AC Operated	SR-T, SRD-T	○	○	○	◎	◎	◎	SR-N, SRD-N	○	○	○	◎	◎	◎
Optional Units	Additional Auxiliary Contact	UT-AX	○	○	○	◎	◎	◎	UN-AX	○	○	○	◎	◎	◎
	Surge Absorber	UT-SA	○	○	-	◎	*	-	UN-SA	○	○	-	◎	*	-
	Mechanical Interlock	UT-ML	○	○	○	◎	*	-	UN-ML	○	○	○	◎	*	-

Note 1. Symbols indicate the following:

○ : Complies/conforms as standard product, ◎ : Certified as standard product, ☆ : Certified with dedicated product, - : Models not yet certified (non-pending), * : Not applicable

Note 2. Compatibility and certification for magnetic starters are obtained for each magnetic contactor and thermal overload relay model name under the condition that the magnetic contactor and thermal overload relay are used in combination.

Note 3. From MS-T series, thermal overload relay 2-element products are not CCC certified.

7.2 Comparison of UL Certified SCCR (Short-Circuit Current Rating)

MS-T Series							MS-N Series						
Model Name	Main Circuit Voltage: 240 VAC Maximum			Main Circuit Voltage: 480 VAC Maximum			Model Name	Main Circuit Voltage: 240 VAC Maximum			Main Circuit Voltage: 480 VAC Maximum		
	SCCR	Low Voltage Circuit Breaker Used		SCCR	Low Voltage Circuit Breaker Used			SCCR	Low Voltage Circuit Breaker Used		SCCR	Low Voltage Circuit Breaker Used	
Maximum Rated Current		Minimum Breaking Current	Maximum Rated Current		Minimum Breaking Current	Maximum Rated Current	Minimum Breaking Current		Maximum Rated Current	Minimum Breaking Current		Maximum Rated Current	Minimum Breaking Current
S-T10 S(D)-T12	10kA	30A	10kA	10kA	30A	18kA	S-N10 S(D)-N11 S(D)-N12	10kA	30A	18kA	10kA	30A	18kA
	25kA	30A	35kA		15A	10kA		25kA	30A	35kA			
		15A	25kA					SD-N11 SD-N12	14kA	20A		14kA	
SD-T12	14kA	20A	14kA										
S(D)-T20	10kA	50A	10kA	10kA	30A	18kA	S-N18 S-N20	10kA	50A	18kA	10kA	50A	18kA
	25kA	50A	35kA		15A	10kA		25kA	50A	35kA			
		15A	25kA					SD-N21	10kA	50A		18kA	
SD-T20	14kA	30A	14kA										
S(D)-T21	10kA	50A	10kA	35kA	50A	50kA	S(D)-N21	10kA	50A	18kA	10kA	50A	18kA
	35kA	50A	50kA		SD-N21	14kA		40A	14kA				
SD-T21	14kA	40A	14kA										
S-T25	10kA	75A	14kA	35kA	75A	50kA	S-N25	10kA	75A	18kA	10kA	75A	18kA
	35kA	75A	50kA		SD-N25	25kA		75A	35kA				
S(D)-T32	10kA	75A	14kA	35kA	75A	50kA	S-N28	10kA	50A	18kA	10kA	50A	18kA
	35kA	75A	50kA		SD-N28	25kA		50A	35kA				
S(D)-T35	10kA	50A	10kA	18kA	75A	18kA	S(D)-N35	10kA	75A	18kA	10kA	75A	18kA
	14kA	40A	14kA		35kA	75A		50kA	25kA	75A		35kA	
	18kA	75A	18kA			SD-N35		14kA	40A	14kA			
	25kA	75A	35kA										
35kA	75A	50kA											
S(D)-T50	10kA	50A	10kA	18kA	100A	18kA	S(D)-N50	14kA	75A	14kA	18kA	100A	18kA
	14kA	75A	14kA		35kA	100A		50kA	18kA	100A		18kA	
	18kA	100A	18kA			SD-N50		25kA	100A	35kA			
	25kA	100A	35kA										
35kA	100A	50kA											
S(D)-T65	14kA	75A	14kA	18kA	100A	18kA	S(D)-N65	14kA	75A	14kA	18kA	100A	18kA
	18kA	100A	18kA		25kA	225A		35kA	18kA	100A		18kA	
	25kA	225A	35kA			SD-N65		25kA	100A	35kA			
S(D)-T80	14kA	75A	14kA	18kA	100A	18kA	S(D)-N80	25kA	225A	35kA	25kA	225A	35kA
	18kA	100A	18kA		25kA	225A		35kA	25kA	225A		35kA	
	25kA	225A	35kA			SD-N80		25kA	225A	35kA			
S(D)-T100	18kA	100A	18kA	25kA	100A	18kA	S(D)-N95	25kA	225A	35kA	25kA	225A	35kA
	25kA	225A	35kA		SD-N95	25kA		225A	35kA				

8. Comparison of Other Specifications

8.1 Maintenance and Inspection

Item	MS-T Target Model Names (Typical Model)		MS-N Target Model Names (Typical Model)	
		Support Availability		Support Availability
Contact Replacement	S-T10 - T32 SD-T12 - T32	Not Available	S-N10 - N25, N28 SD-N11 - N21	Available
	SR-T5,9 SRD-T5,9	Not Available	SR-N4 - N8 SRD-N4 - N8	Not Available
	S-T35 - T100 SD-T35 - T100	Available	S-N35 - N95 SD-N35 - N95	Available
Coil Replacement	S-T10 - T32 SD-T12 - T32	Not Available	S-N10 - N25, N28 SD-N11 - N21	Available
	SR-T5,9 SRD-T5,9	Not Available	SR-N4 - N8 SRD-N4 - N8	Available
	S-T35 - T100 SD-T35 - T100	Available	S-N35 - N95 SD-N35 - N95	Available
Contact Inspection	S-T10 - T32 SD-T12 - T32	Not Available	S-N10 - N25, N28 SD-N11 - N21	Available
	SR-T5,9 SRD-T5,9	Not Available	SR-N4 - N8 SRD-N4 - N8	Available
	S-T35 - T100 SD-T35 - T100	Available	S-N35 - N95 SD-N35 - N95	Available

Note 1. Mechanically latched magnetic contactors are calibrated assembled products. Neither MS-T nor MS-N series can be replaced, inspected or disassembled.

9. Comparison of External Dimensions/Mounting Dimensions

9.1 Enclosed Type Magnetic Starters (Non-Reversing)

MS-T Series	MS-N Series
<p>MS-T10</p>	<p>MS-N10</p>
<p>MS-T12</p>	<p>MS-N11,N12</p>
<p>MS-T21</p>	<p>MS-N20,N21</p>

MS-T Series

MS-T35

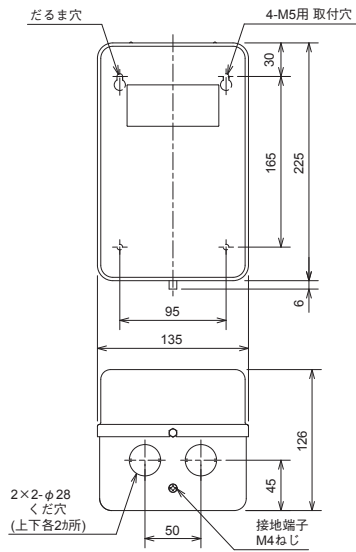

MS-N Series

MS-N25,N35

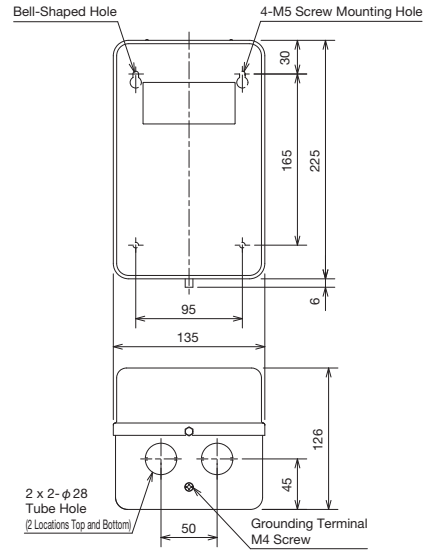

MS-T50

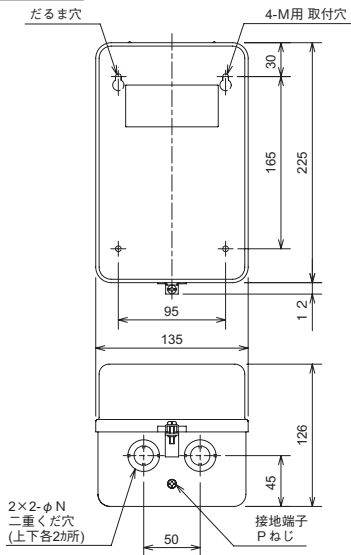

MS-N50

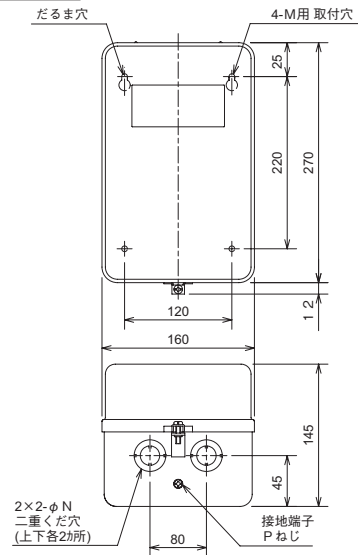

MS-T65

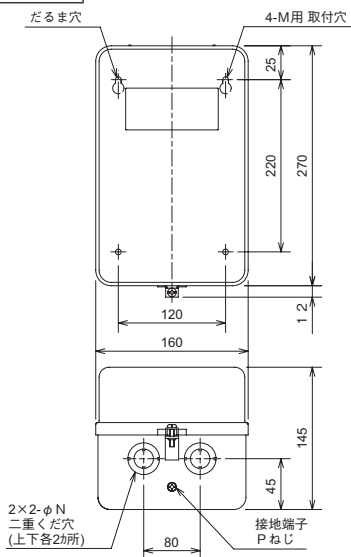

MS-N65

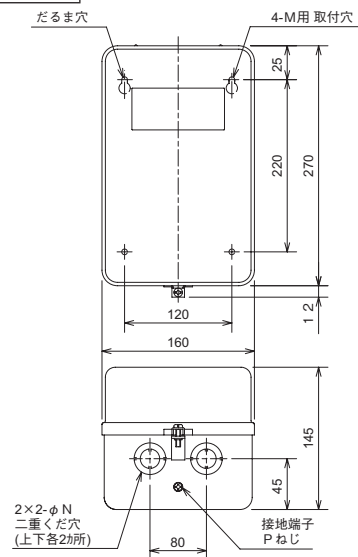

MS-T Series

MS-T80

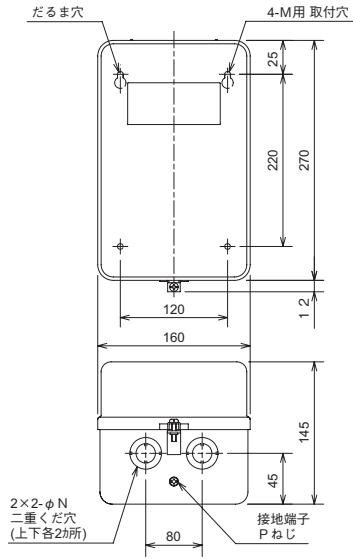

MS-N Series

MS-N80

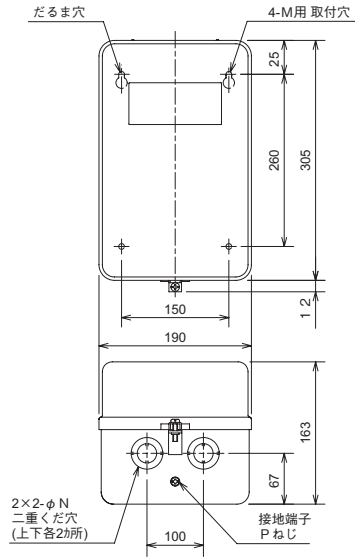

MS-T100

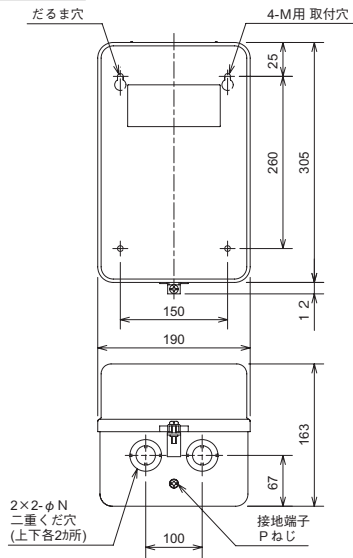

MS-N95

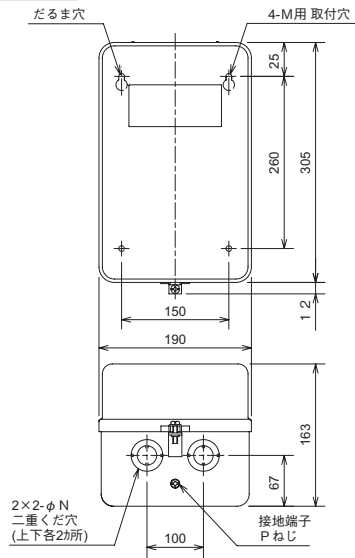

9.2 Open Type Magnetic Starters (Non-Reversing)

[AC Operated]

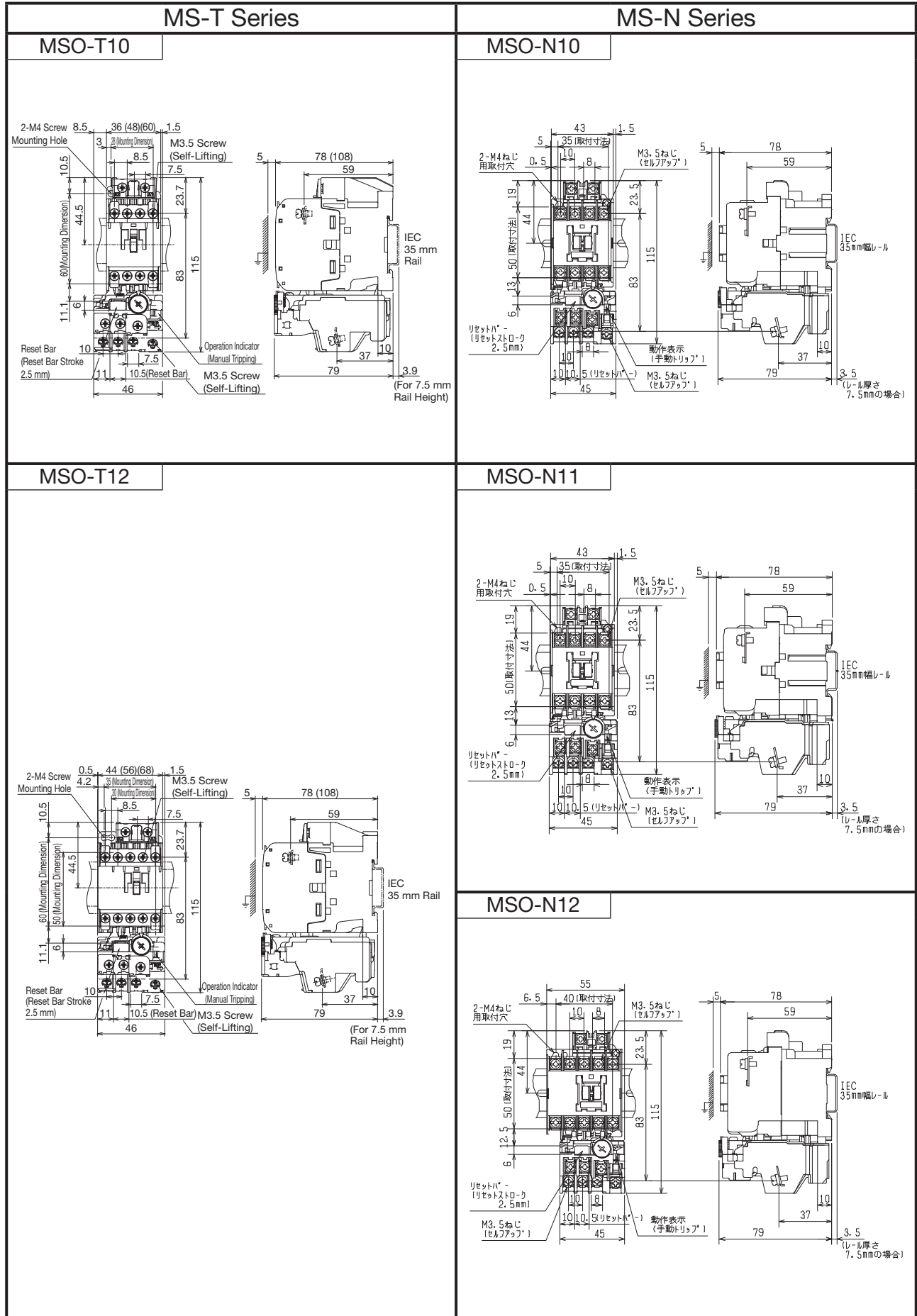

MS-T Series

MSO-T20

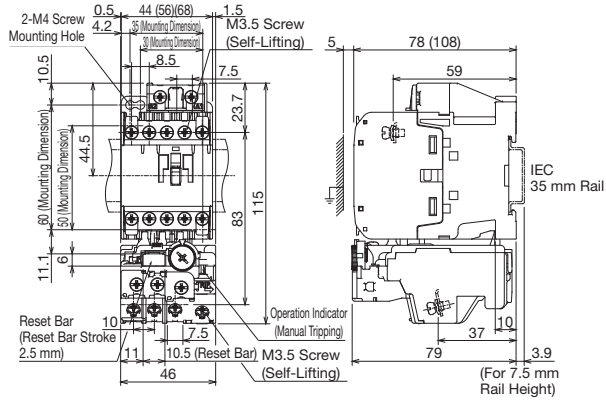

MS-N Series

MSO-N18

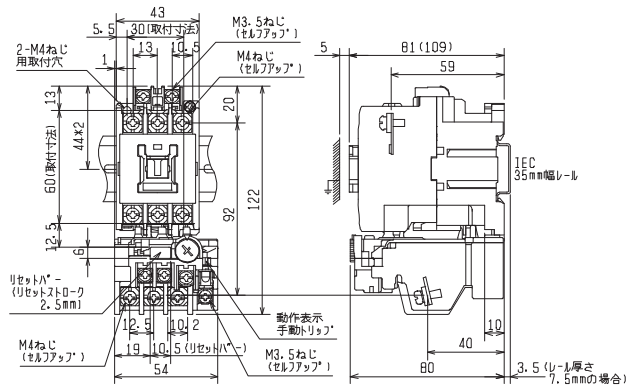

MSO-N20

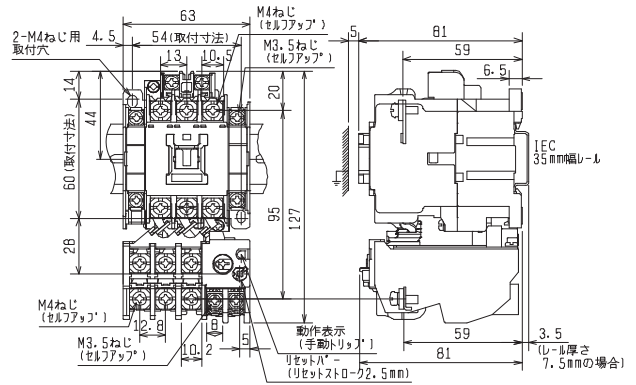

MSO-T21

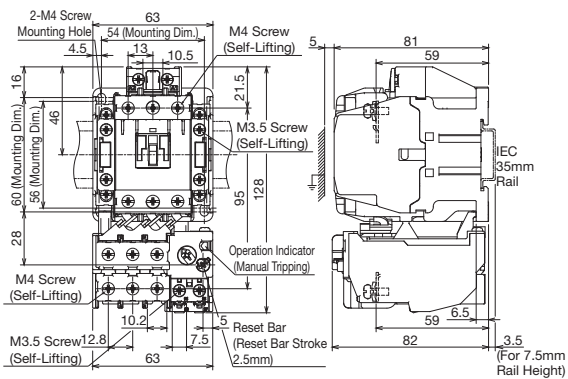

MSO-N21

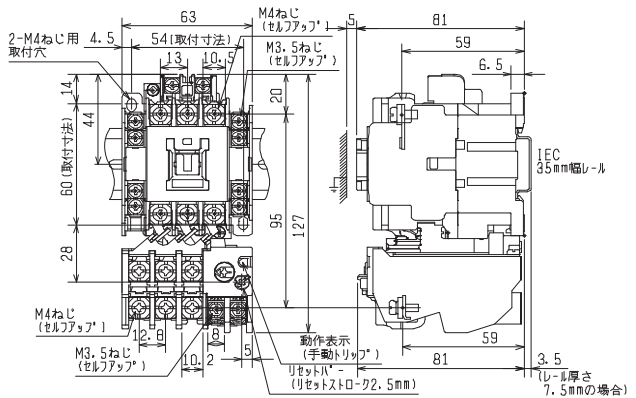

MS-T Series

MSO-T25

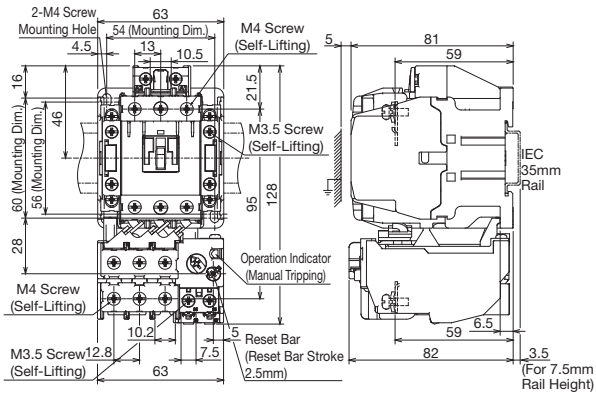

MS-N Series

MSO-N25

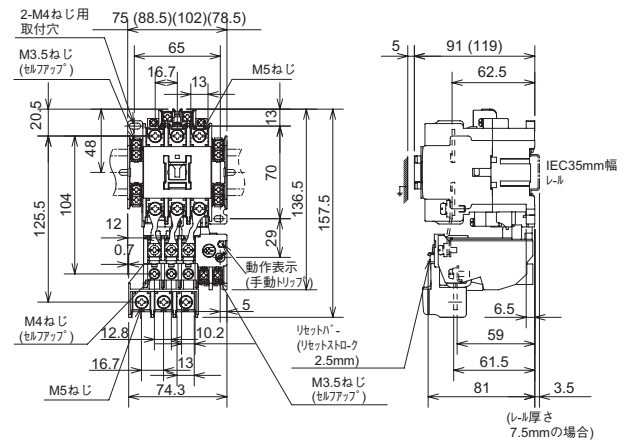

MSO-T35

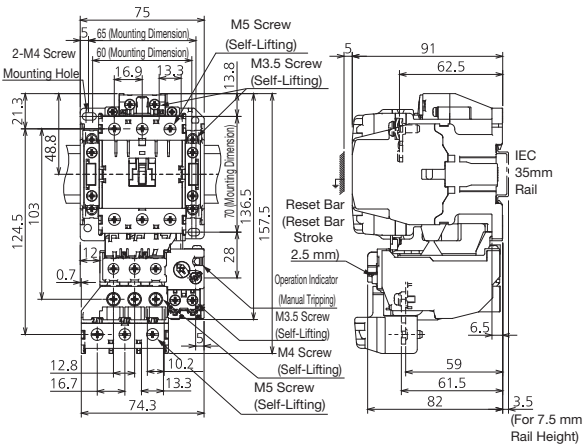

MSO-N35

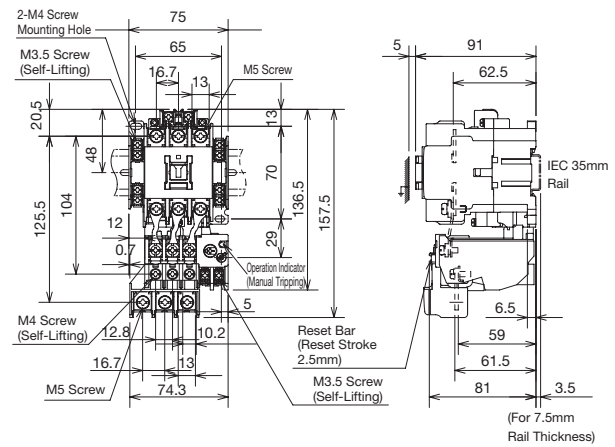

MSO-T50

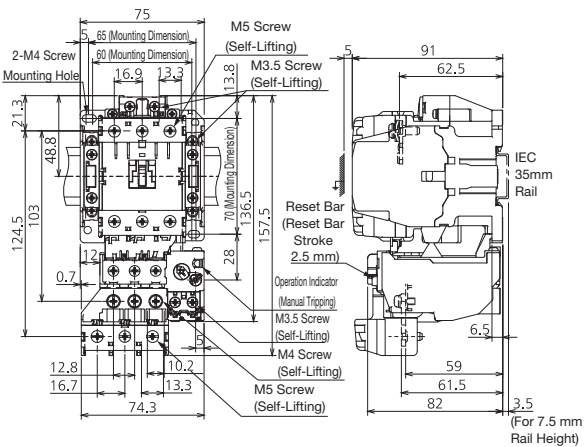

MSO-N50

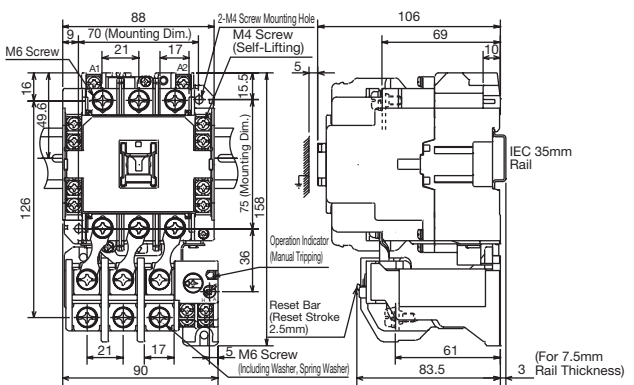

MS-T Series

MSO-T65

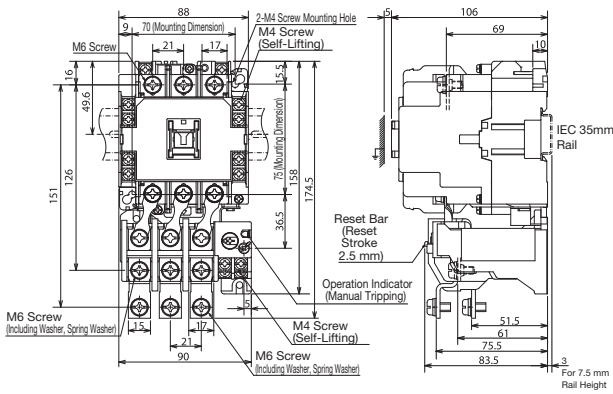

MS-N Series

MSO-N65

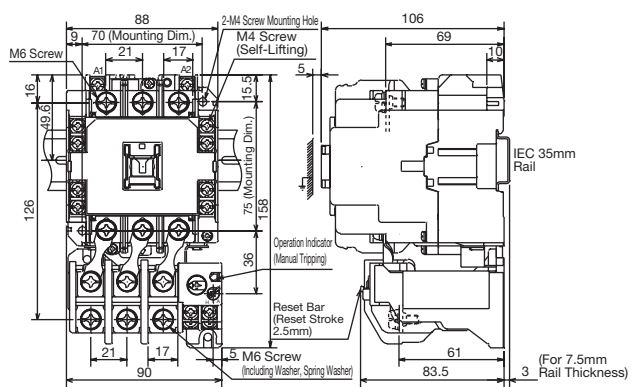

MSO-T80

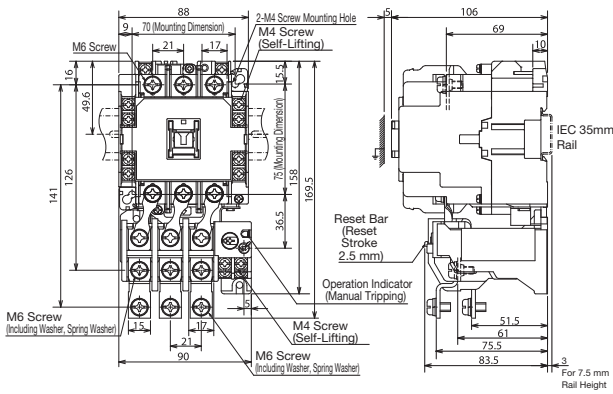

MSO-N80

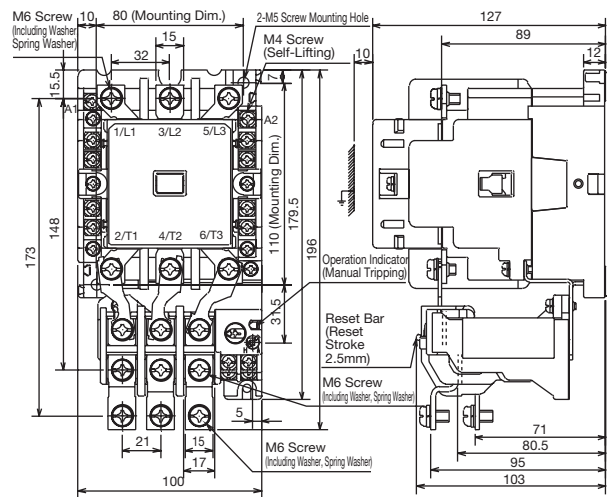

MSO-T100

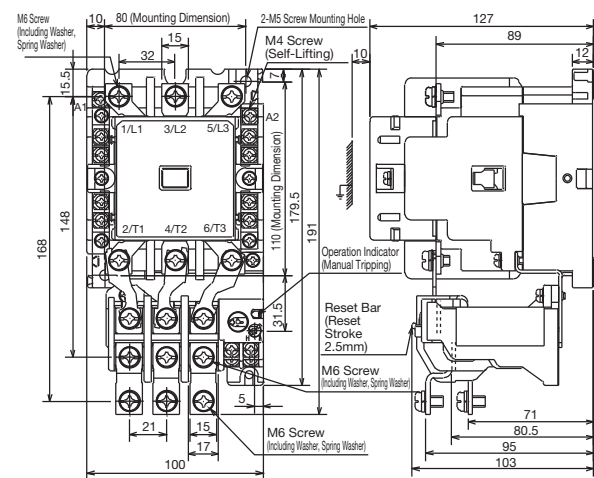

MSO-N95

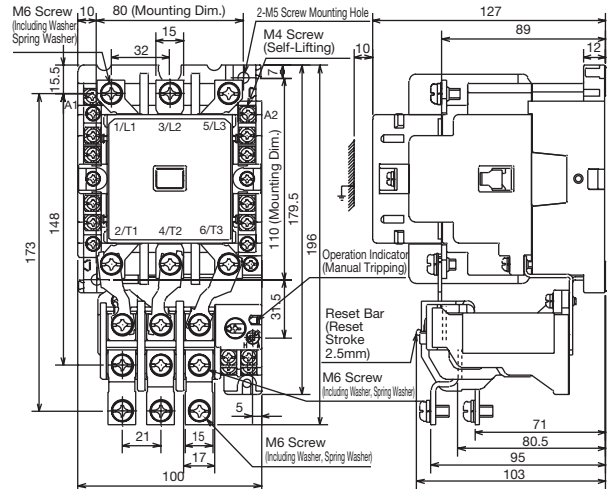

9.2 Open Type Magnetic Starters (Non-Reversing) [continued]

[DC Operated]

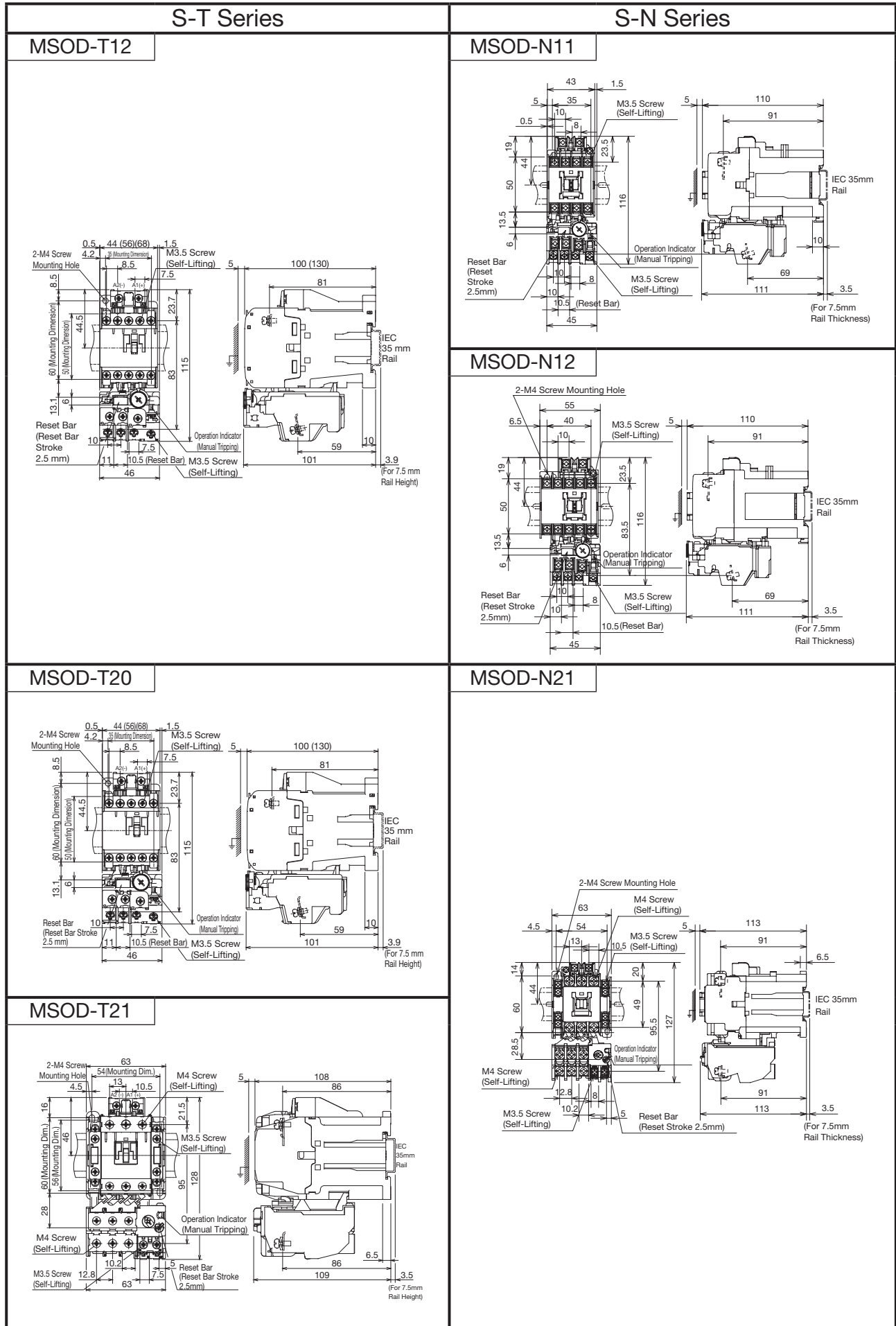

S-T Series

MSOD-T35

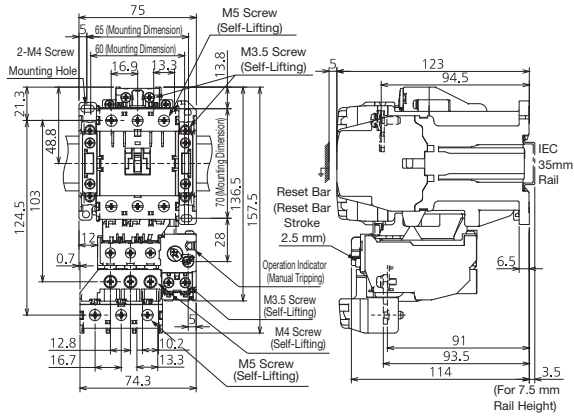

S-N Series

MSOD-N35

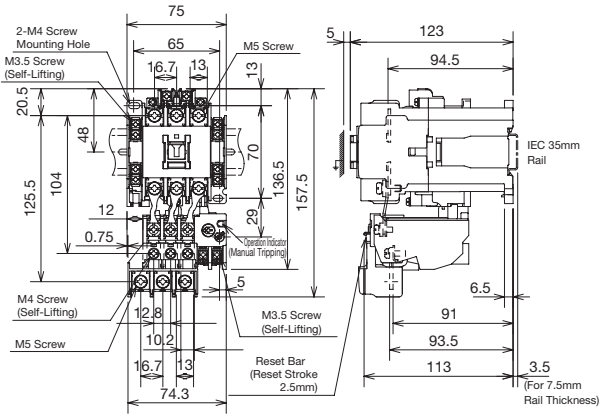

MSOD-T50

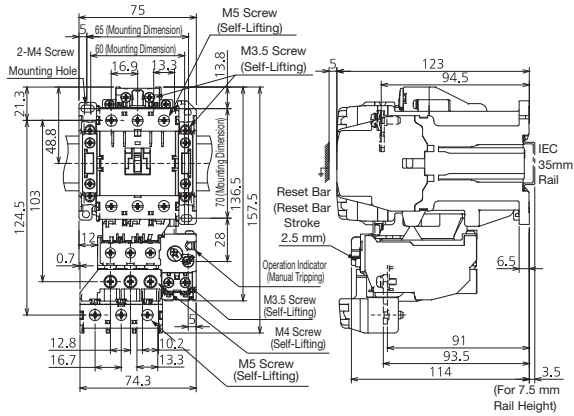

MSOD-N50

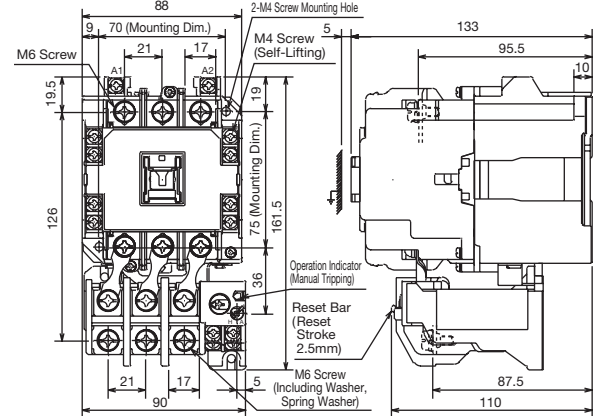

S-T Series

MSOD-T65

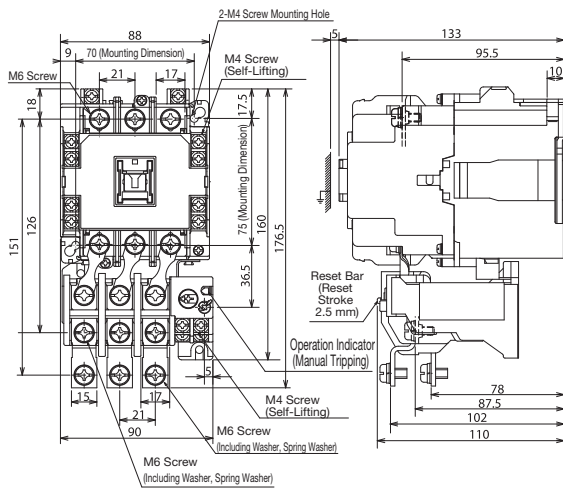

S-N Series

MSOD-N65

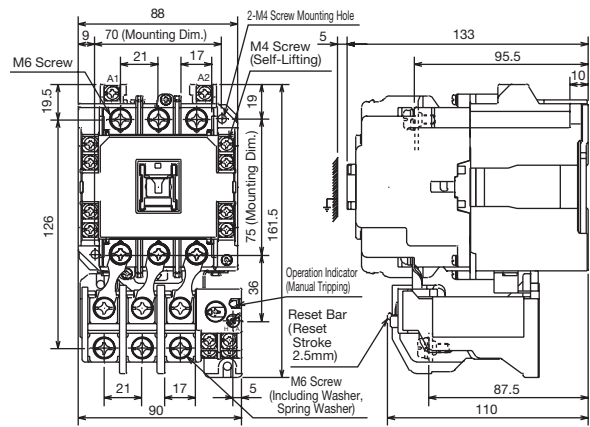

MSOD-T80

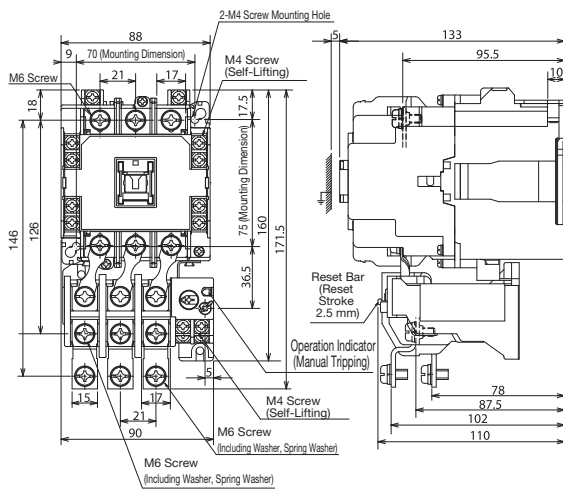

MSOD-N80

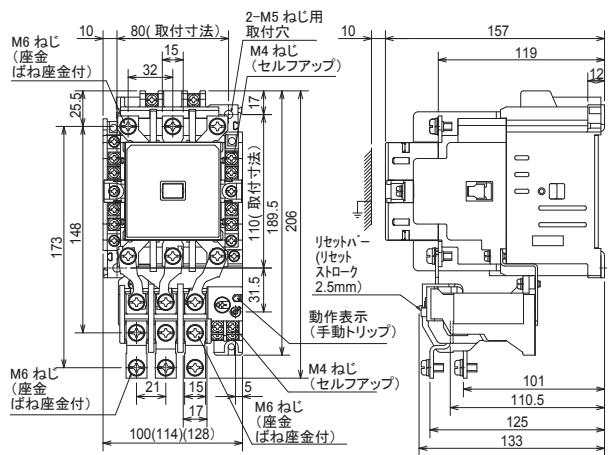

MSOD-T100

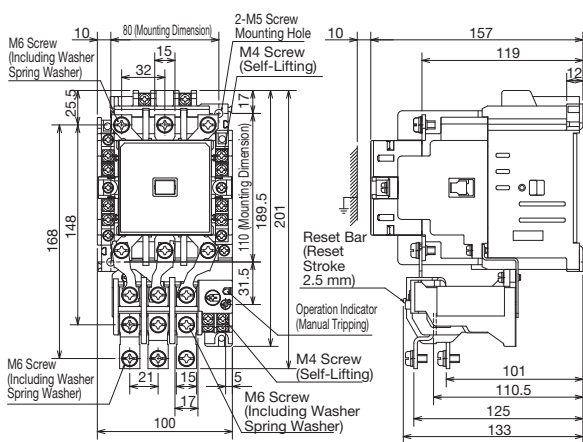

MSOD-N95

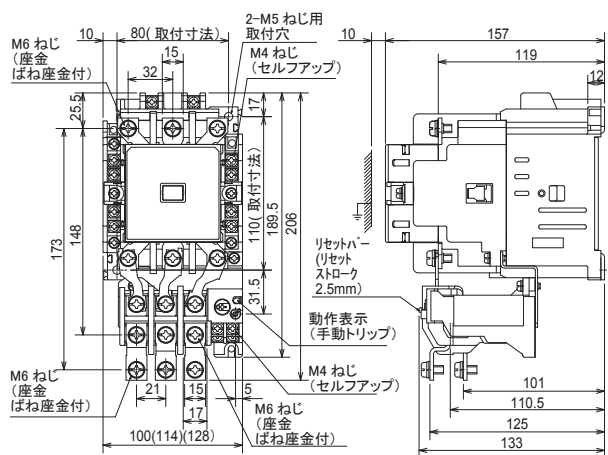

9.3 Magnetic Contactors (Non-Reversing)

[AC Operated]

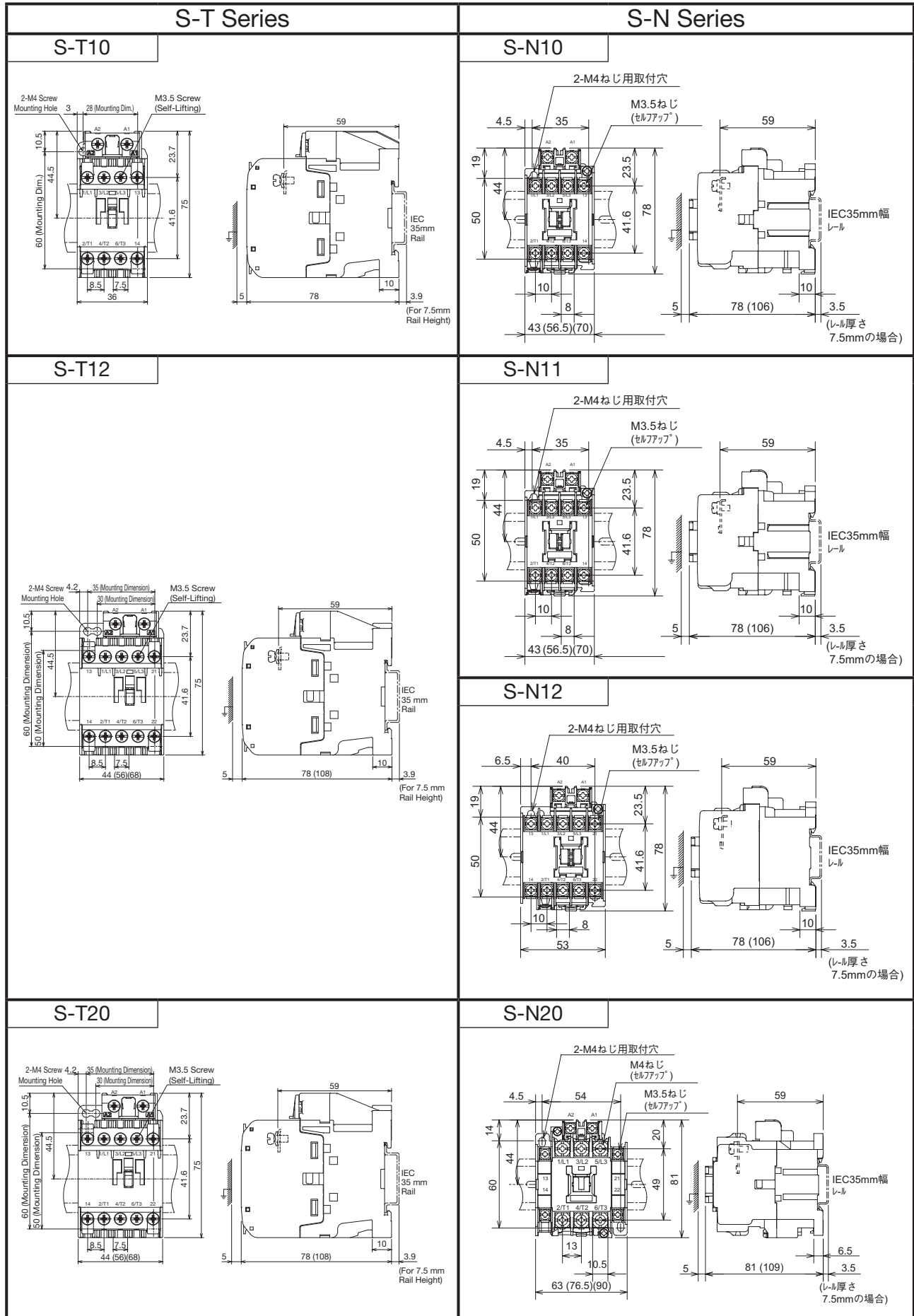

S-T Series

S-T21

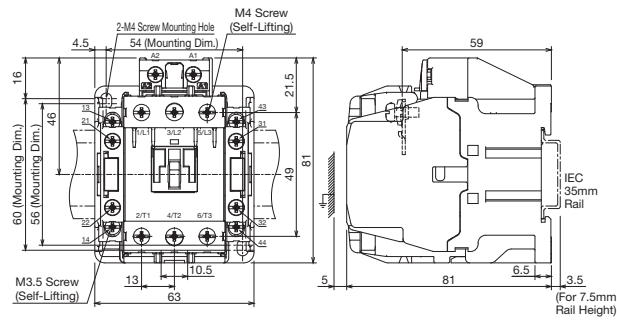

S-N Series

S-N21

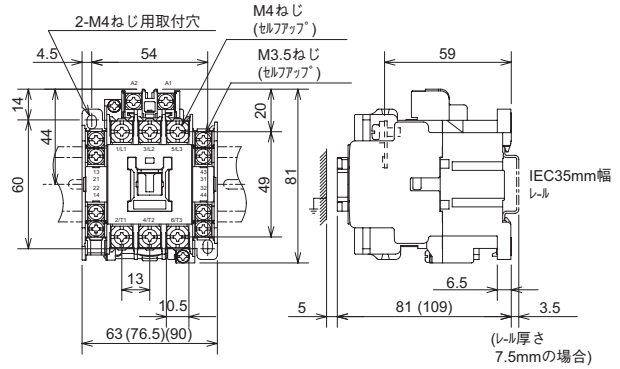

S-T25

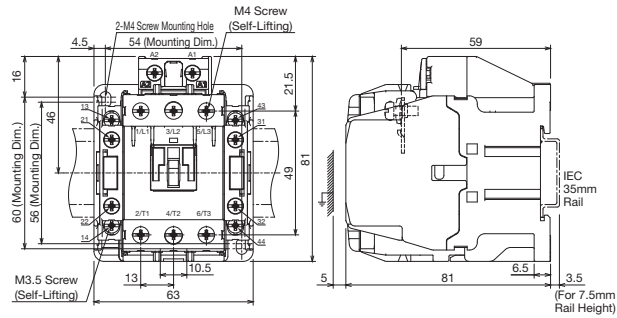

S-N25

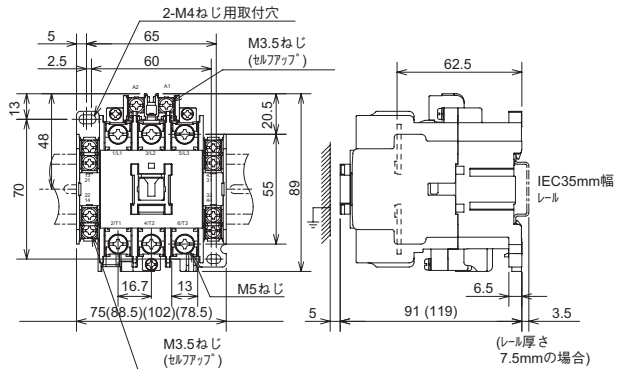

S-T32

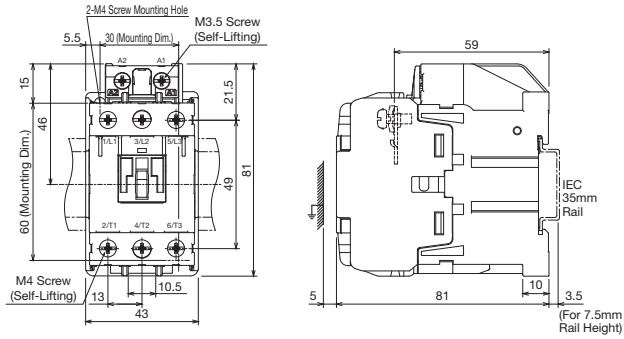

S-N18/N28

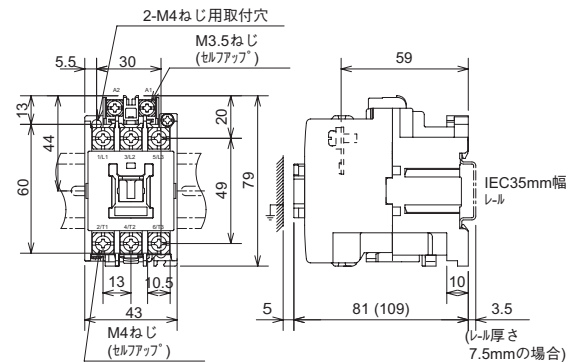

S-T35

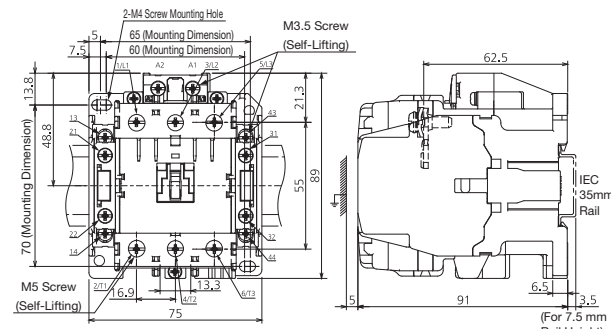

S-N35

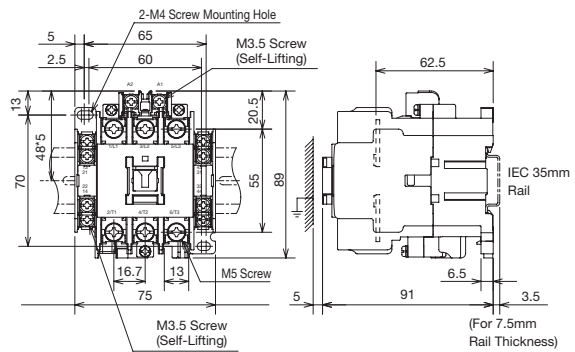

S-T Series

S-T50

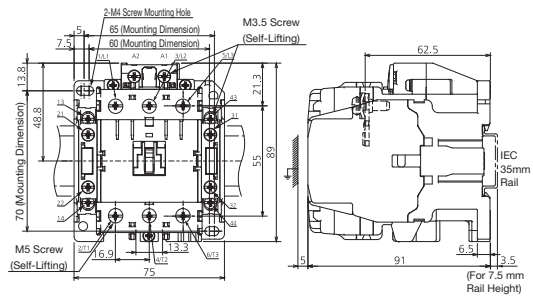

S-N Series

S-N50

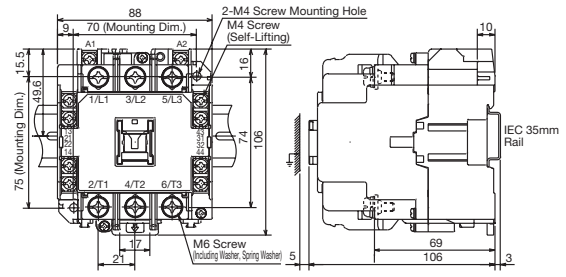

S-T65

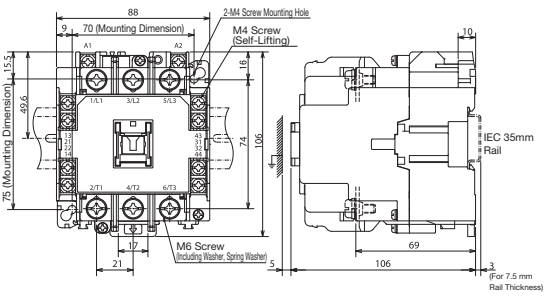

S-N65

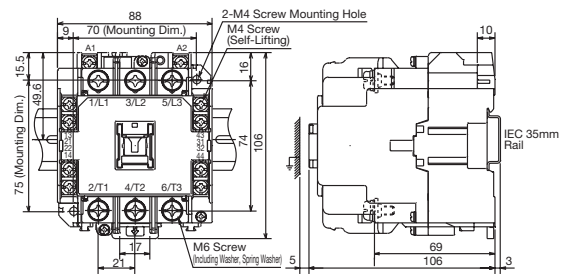

S-T80

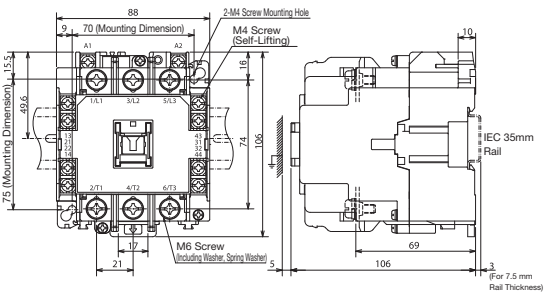

S-N80

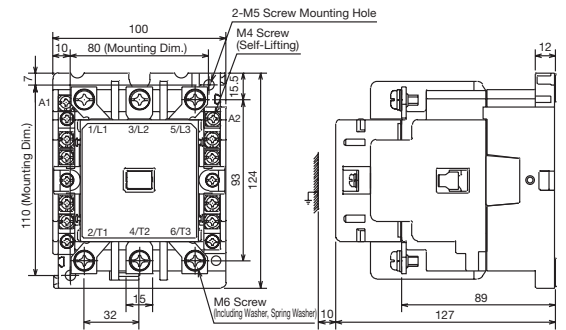

S-T100

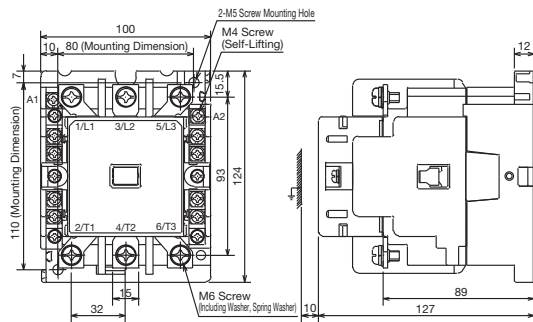

S-N95

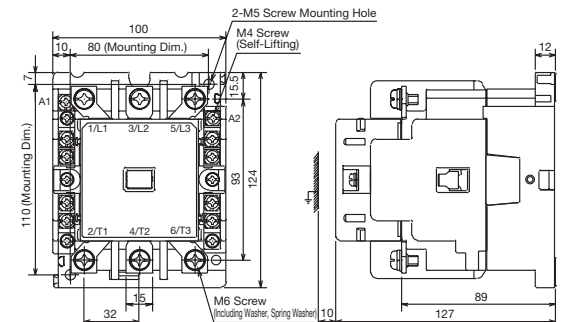

9.3 Magnetic Contactors (Non-Reversing) [continued]
 [DC Operated]

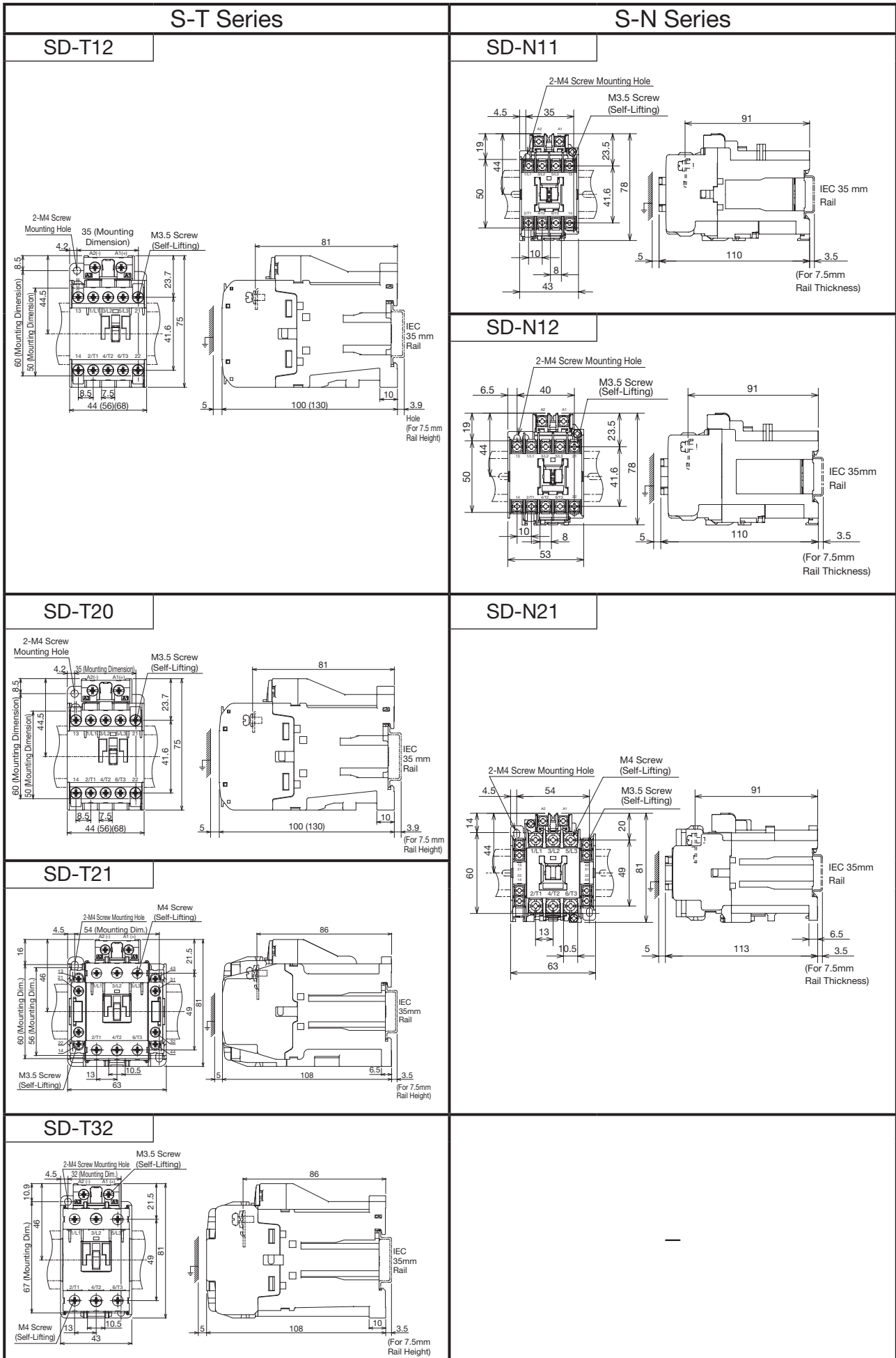

S-T Series

SD-T35

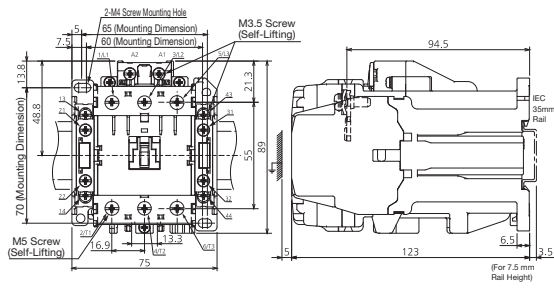

S-N Series

SD-N35

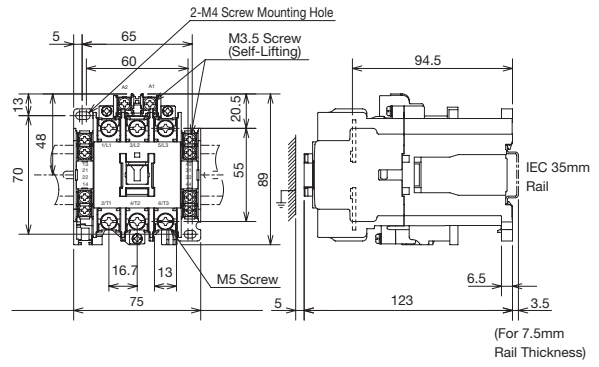

SD-T50

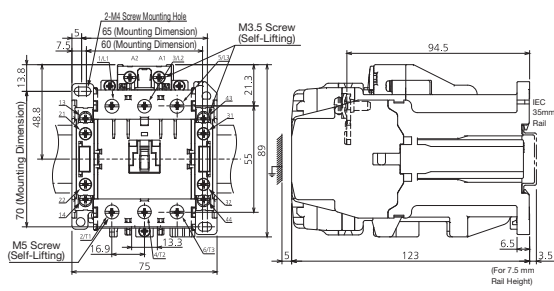

SD-N50

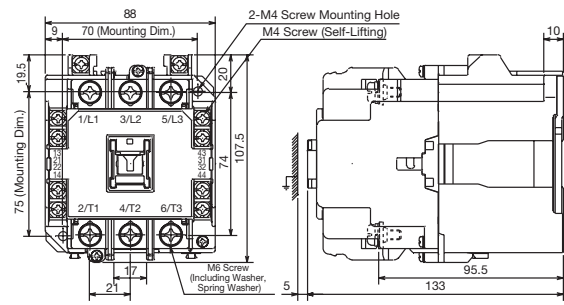

SD-T65

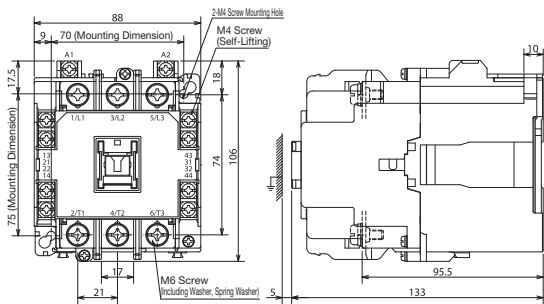

SD-N65

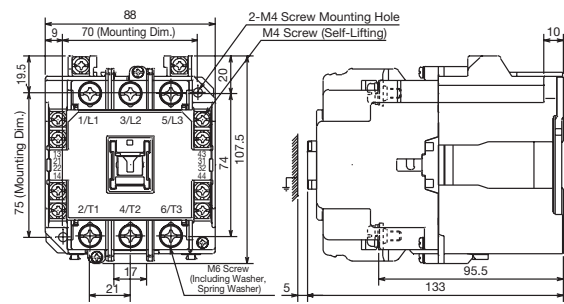

S-T Series

SD-T80

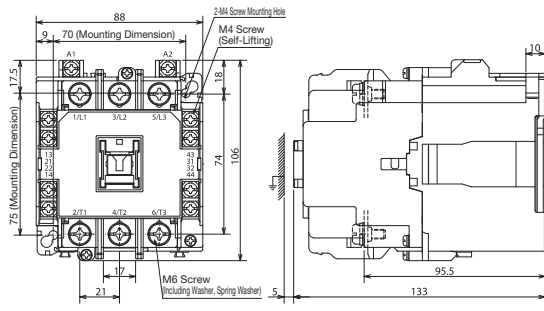

S-N Series

SD-N80

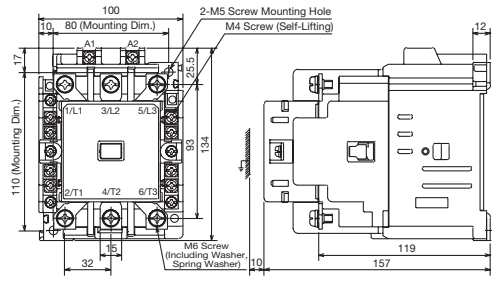

SD-T100

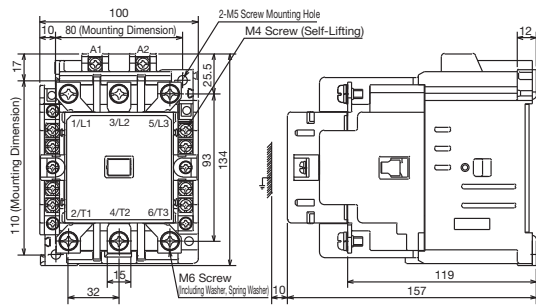

SD-N95

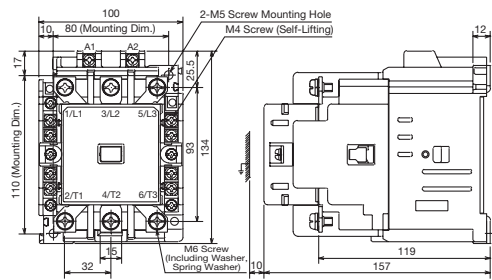

9.3 Magnetic Contactors (Non-Reversing) [continued]

[Mechanically Latched Type]

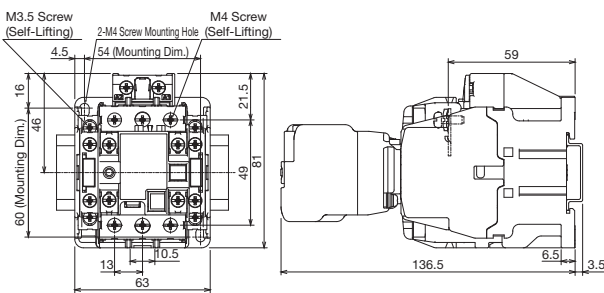
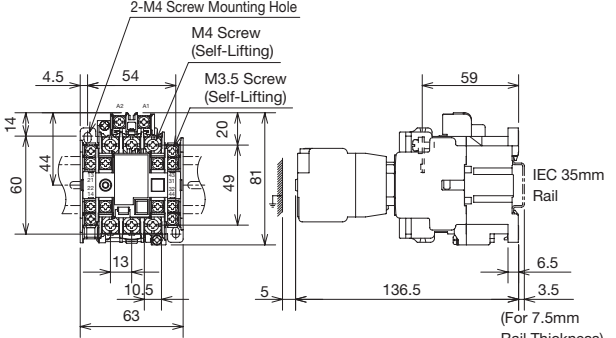
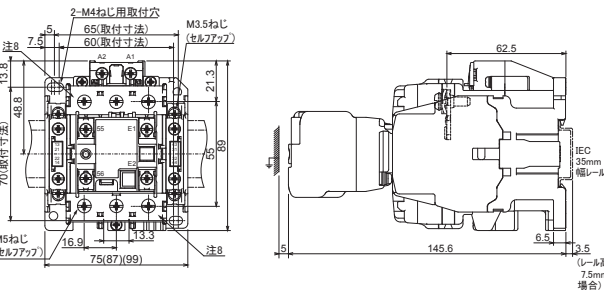
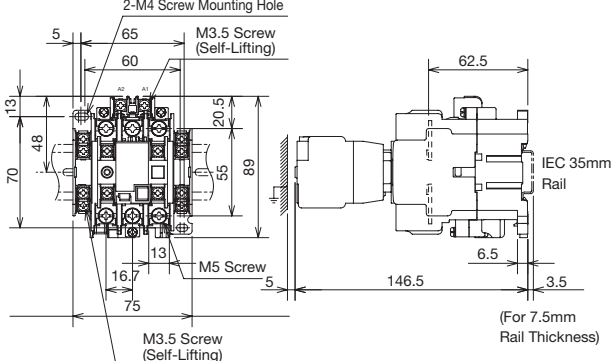
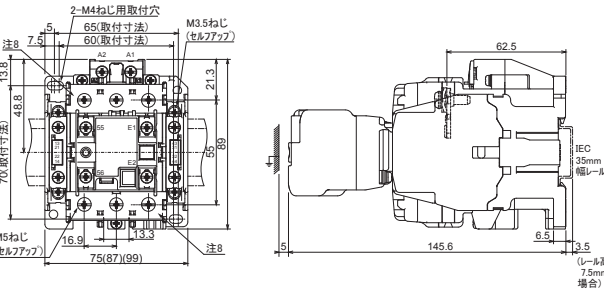
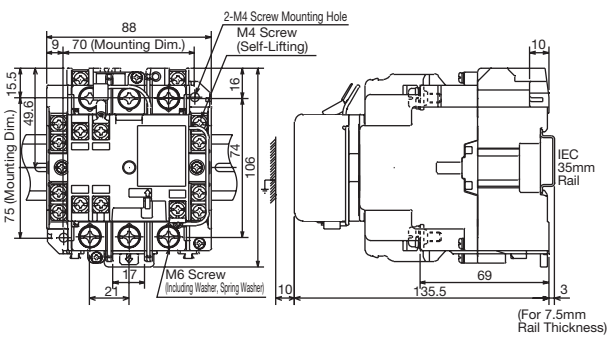
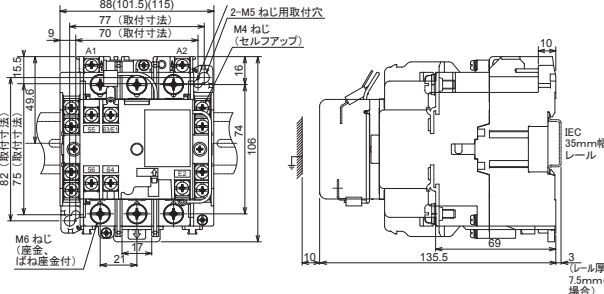
S-T Series	S-N Series
<p>SL(D)-T21</p> 	<p>SL(D)-N21</p> 
<p>SL(D)-T35</p> 	<p>SL(D)-N35</p> 
<p>SL(D)-T50</p> 	<p>SL(D)-N50(FN)</p> 
<p>SL(D)-T50FN (Class 2 Heat-Resistant Type)</p> 	

S-T Series

SL(D)-T65

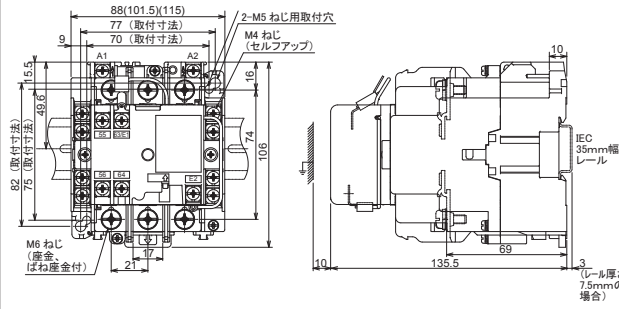

S-N Series

SL(D)-N65

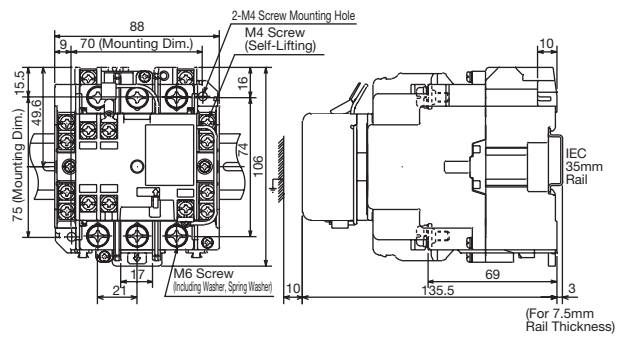

SL(D)-T80

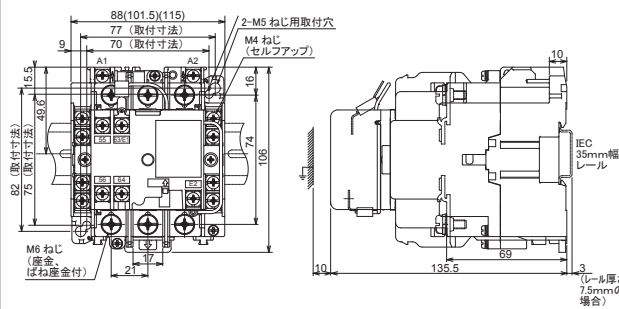

SL(D)-N80

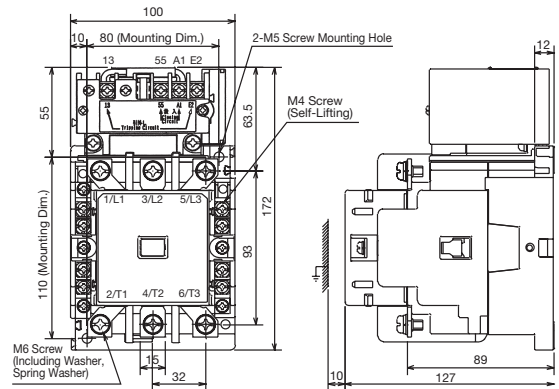

SL(D)-T100

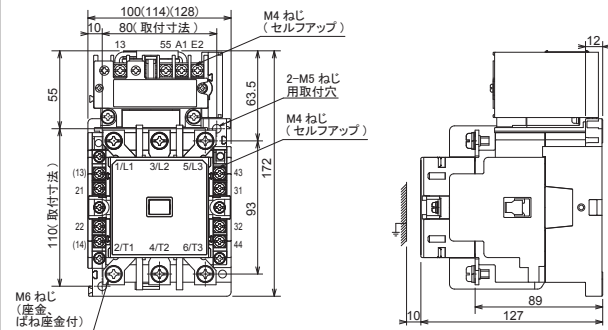

SL(D)-N95

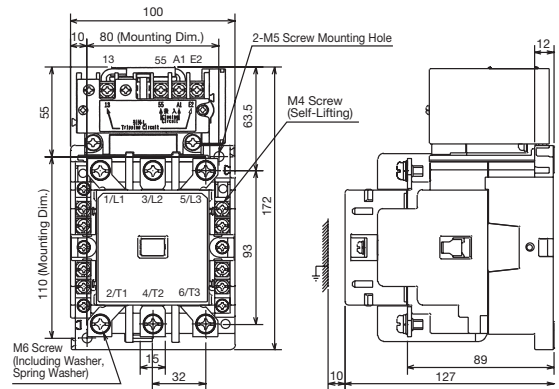

9.4 Enclosed Type Magnetic Starters (Reversing)

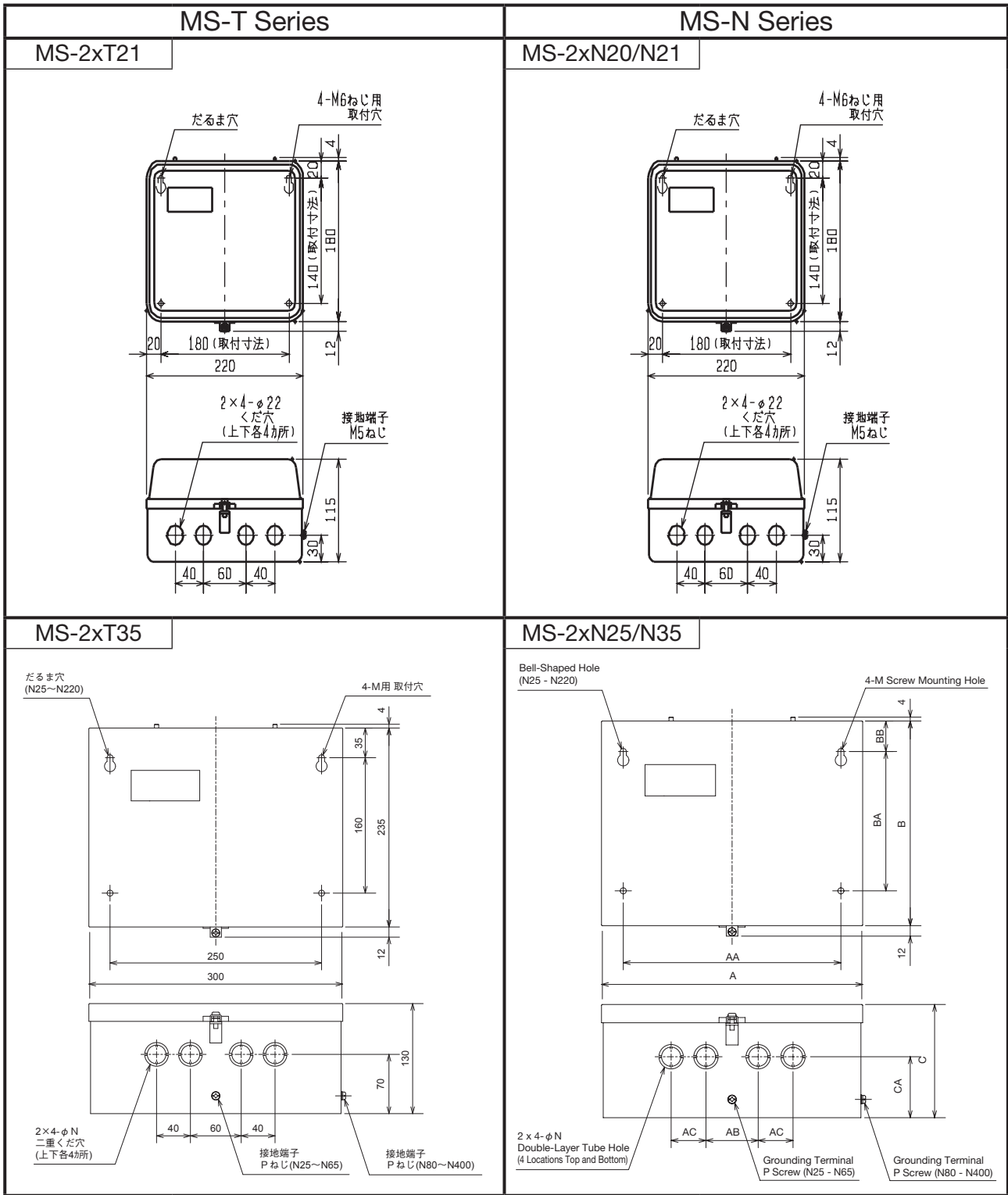

MS-T Series

MS-2xT50

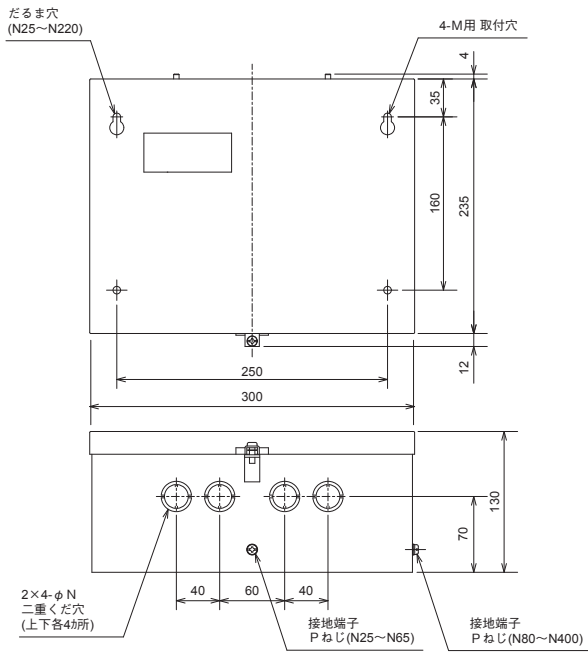

MS-N Series

MS-2xN50

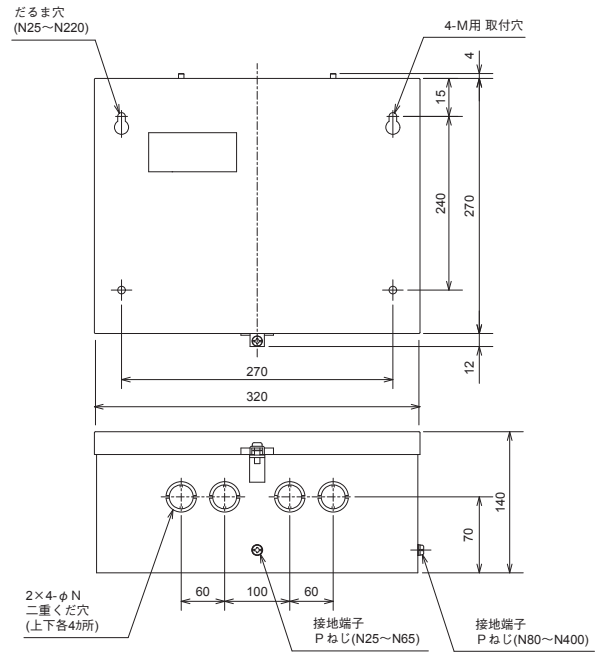

MS-2xT65

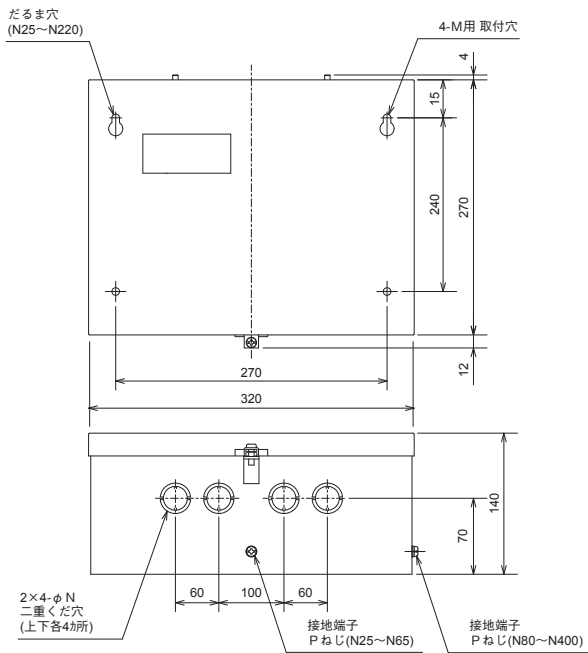

MS-2xN65

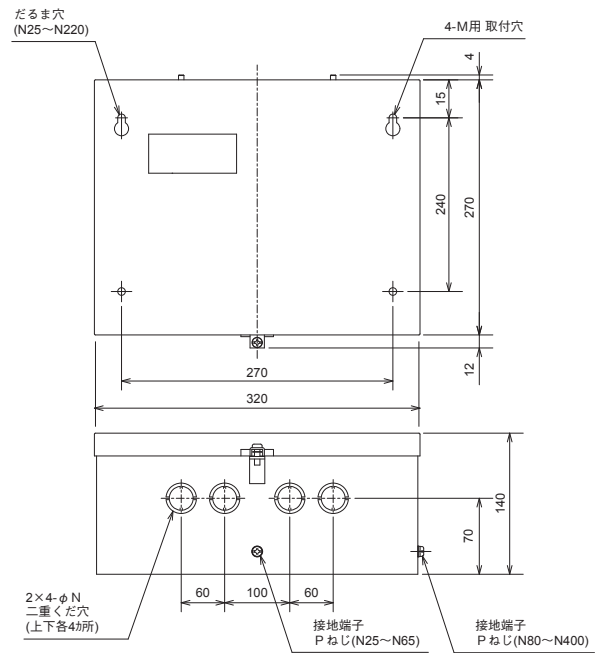

MS-T Series

MS-2xT80

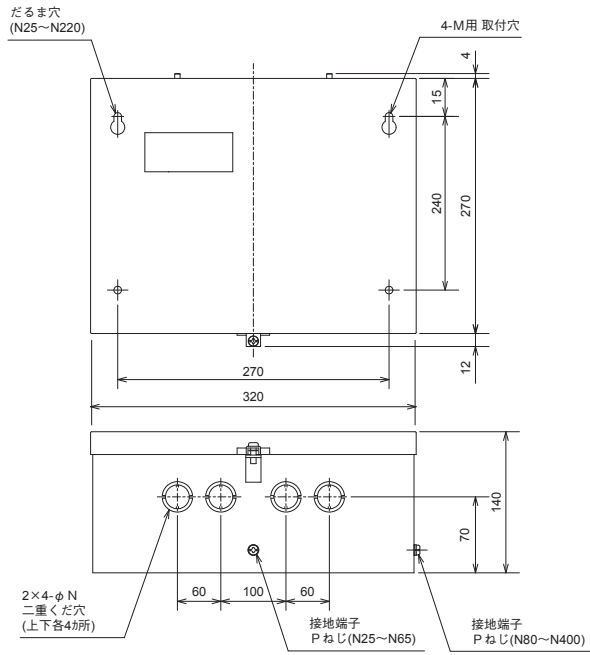

MS-N Series

MS-2xN80

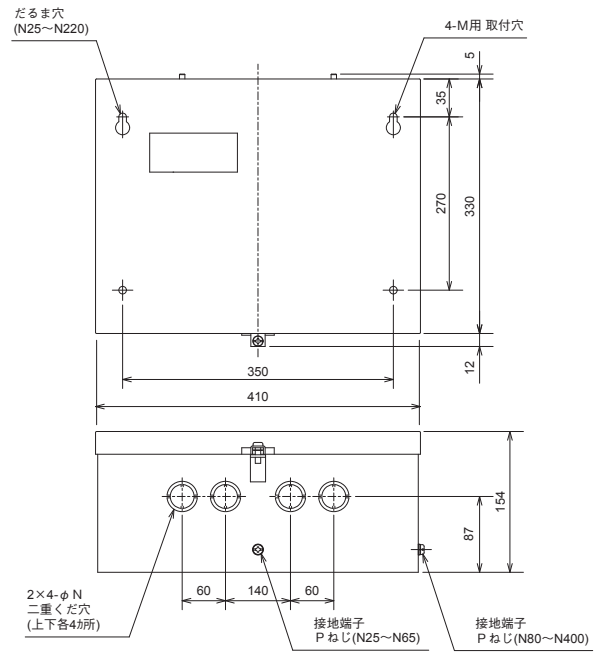

MS-2xT100

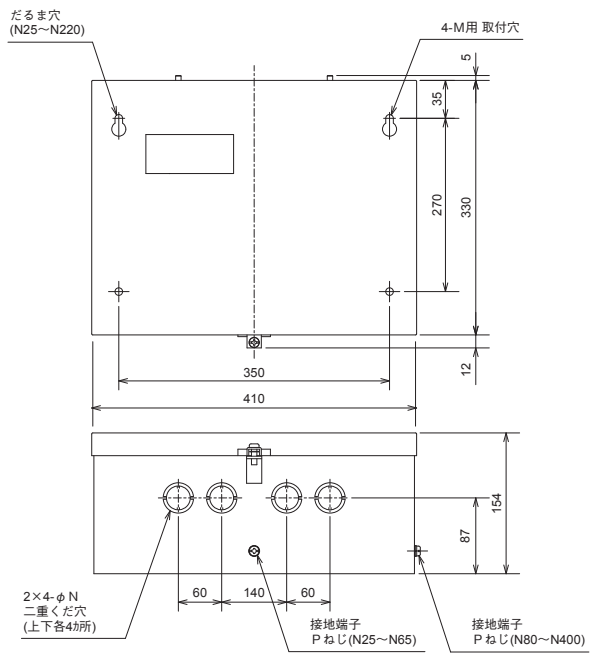

MS-2xN95

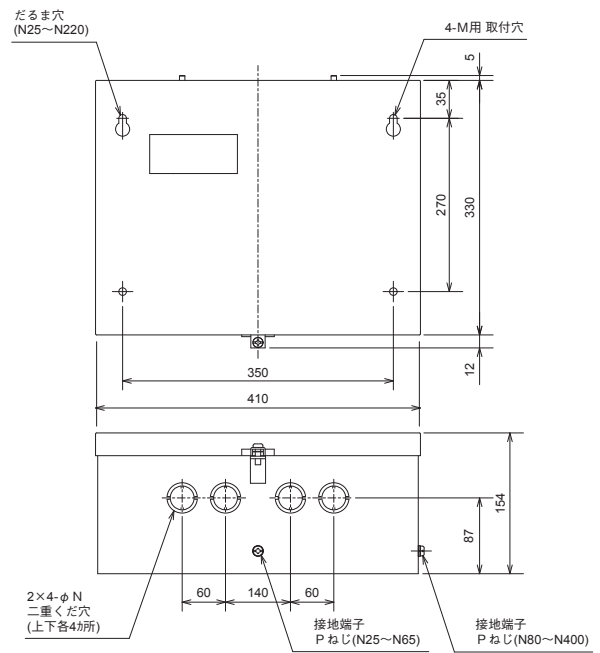

9.5 Open Type Magnetic Starters (Reversing)

[AC Operated]

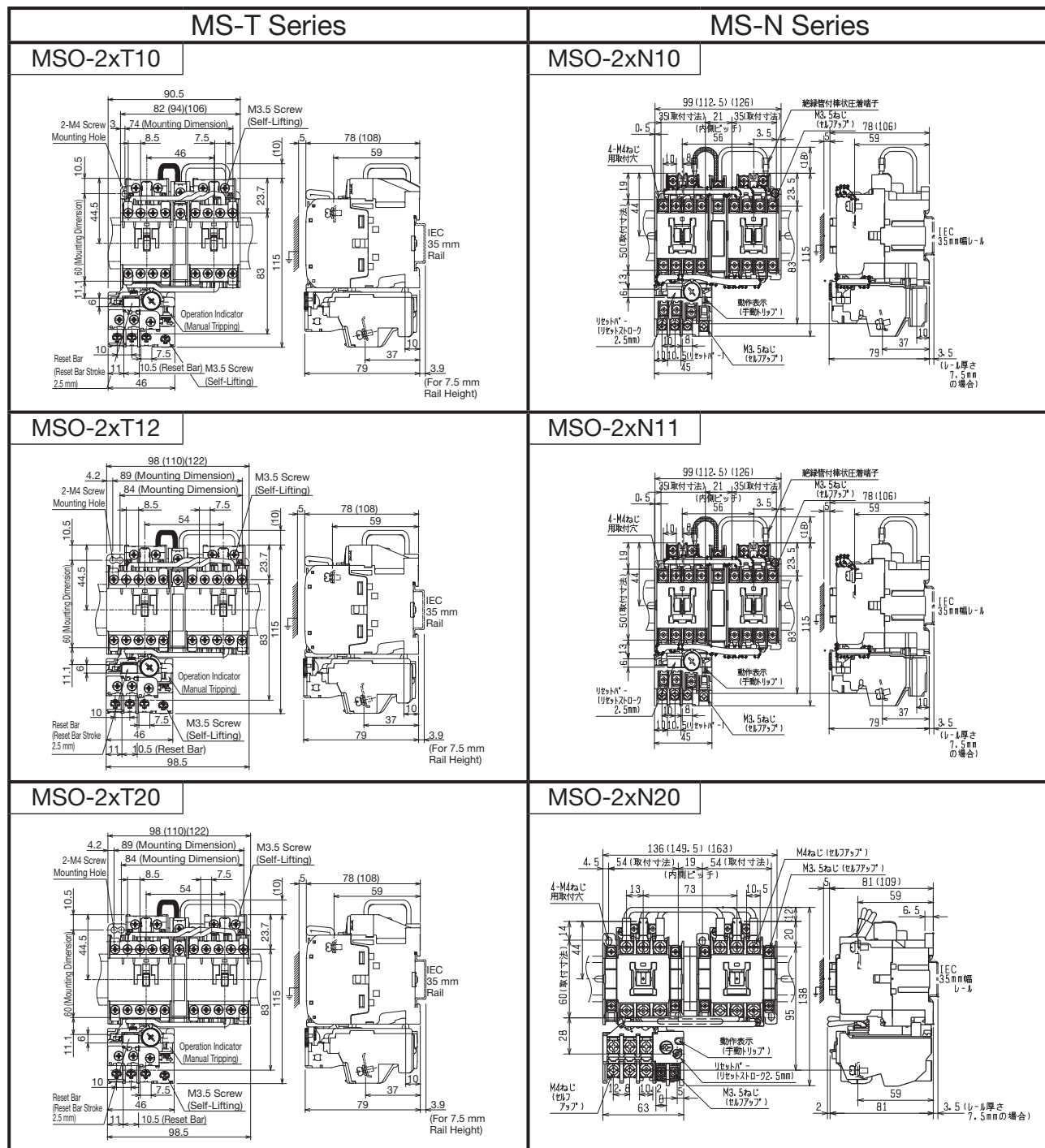

MS-T Series

MSO-2xT21

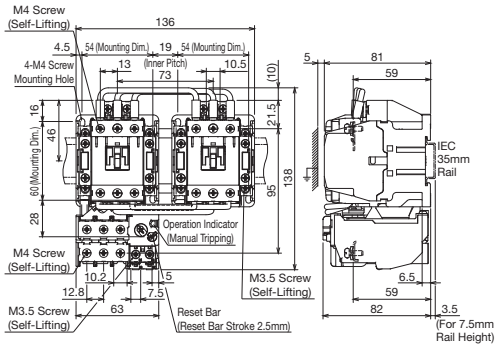

MSO-2xT25

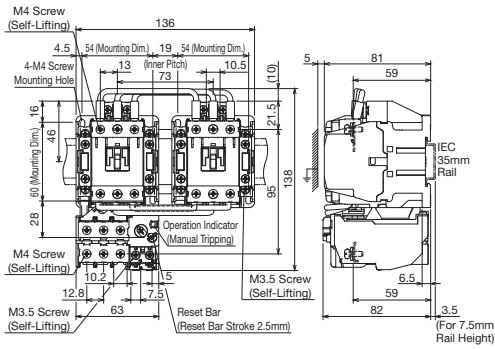

MSO-2xT35

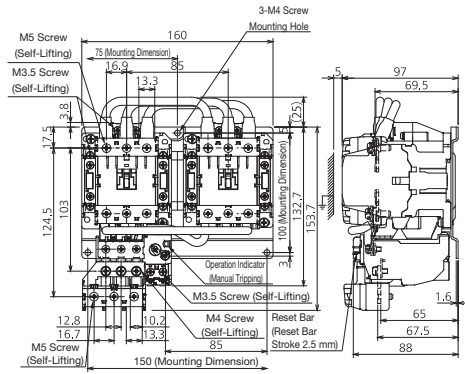

MSO-2xT50

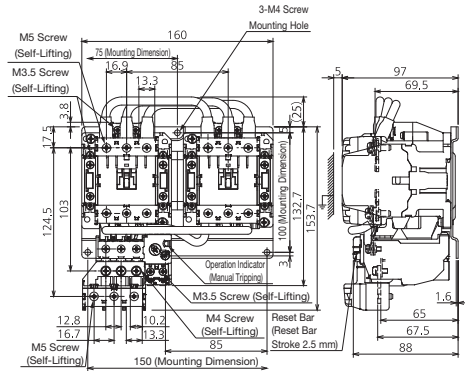

MS-N Series

MSO-2xN21

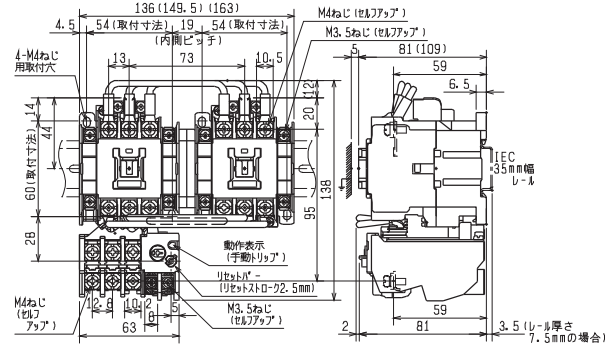

MSO-2xN25

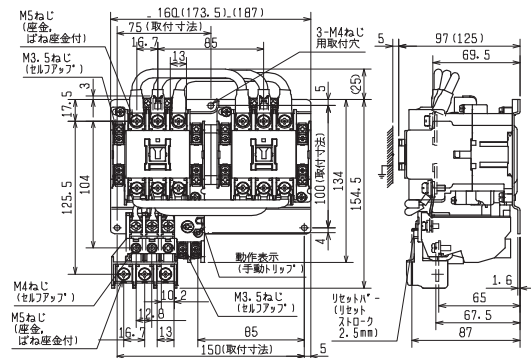

MSO-2xN35

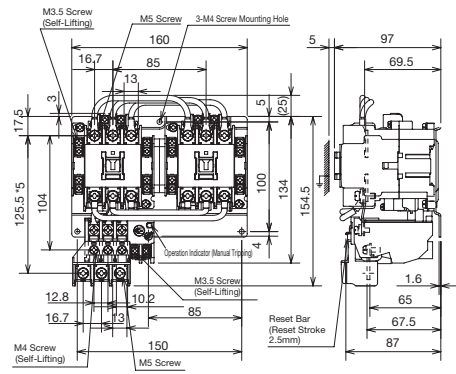

MSO-2xN50

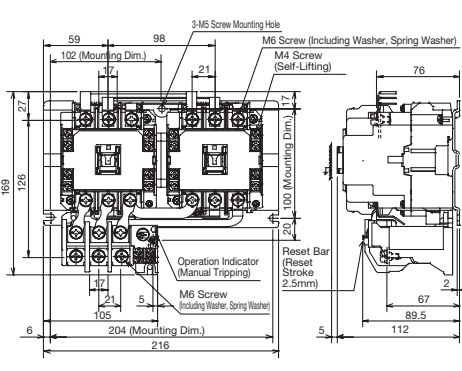

MS-T Series

MSO-2xT65

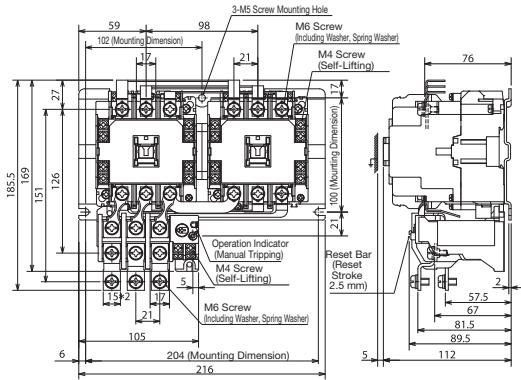

MS-N Series

MSO-2xN65

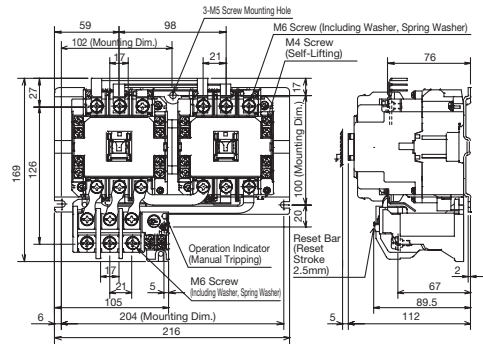

MSO-2xT80

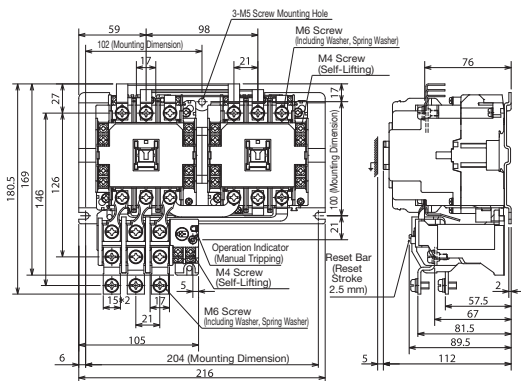

MSO-2xN80

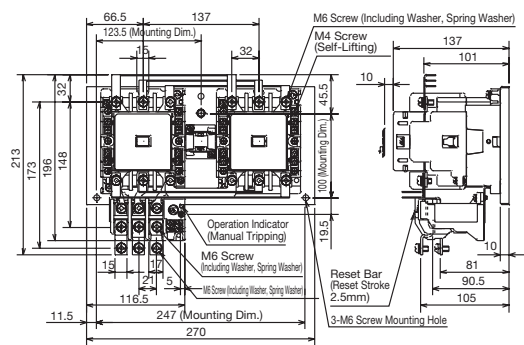

MSO-2xT100

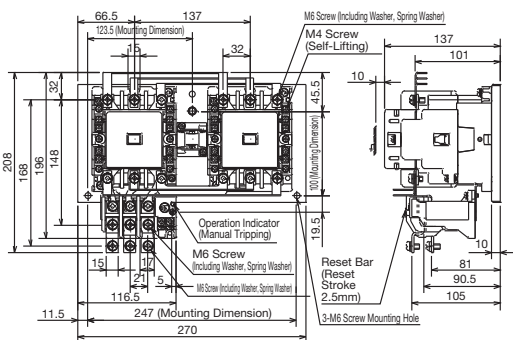

MSO-2xN95

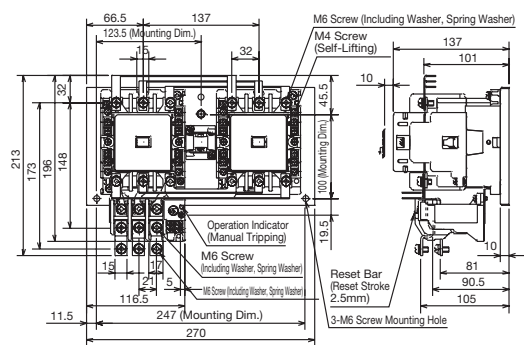

9.5 Open Type Magnetic Starters (Reversing) [continued]

[DC Operated]

S-T Series	S-N Series
<p>MSOD-2xT12</p> <p>2-M4 Screw Mounting Hole 98(110)(122) 4.2 89 (Mounting Dimension) M3.5 Screw (Self-Lifting) 8.5 7.5 8.5 44.5 83 115 13.1 10 10.5 (Reset Bar) 98.5 Reset Bar (Reset Bar Stroke 2.5 mm) M3.5 Screw (Self-Lifting) 7.5 46 Operation Indicator (Manual Tripping) 100 (130) 81 5 10 IEC 35 mm Rail 3.9 (For 7.5 mm Rail Height)</p>	<p>MSOD-2xN11</p> <p>99 M3.5 Screw (Self-Lifting) 0.5 35 21 35 5 110 4-M4 Screw Mounting Hole 10 8 56 3.5 (18) 1.19 44 23.5 50 116 13.5 6 Reset Bar (Reset Stroke 2.5mm) 10 8 10.5 (Reset Bar) 45 M3.5 Screw (Self-Lifting) Operation Indicator (Manual Tripping) 110 91 IEC 35mm Rail 10 111 69 3.5 (For 7.5mm Rail Thickness)</p>
<p>MSOD-2xT20</p> <p>2-M4 Screw Mounting Hole 98 (110)(122) 4.2 89 (Mounting Dimension) M3.5 Screw (Self-Lifting) 8.5 7.5 8.5 44.5 83 115 13.1 10 10.5 (Reset Bar) 98.5 Reset Bar (Reset Bar Stroke 2.5 mm) M3.5 Screw (Self-Lifting) 7.5 46 Operation Indicator (Manual Tripping) 100 (130) 81 5 10 IEC 35 mm Rail 3.9 (For 7.5 mm Rail Height)</p>	<p>MSOD-2xN21</p> <p>3-M4 Screw Mounting Hole 160 M4 Screw (Self-Lifting) 136 M3.5 Screw (Self-Lifting) 73 10.5 5 5 119 97 20.5 90 133 95.5 13.5 12.8 80 M4 Screw (Self-Lifting) 10.2 85 M3.5 Screw (Self-Lifting) 150 Reset Bar (Reset Stroke 2.5mm) Operation Indicator (Manual Tripping) 119 97 2</p>
<p>MSOD-2xT21</p> <p>M4 Screw (Self-Lifting) 160 3-M4 Screw Mounting Hole 136 M3.5 Screw (Self-Lifting) 10.5 5 114 81 92 95 133 80 (Mounting Dim.) 6 12.5 12.8 80 Operation Indicator (Manual Tripping) 10.2 85 1.50 (Mounting Dim.) Reset Bar (Reset Bar Stroke 2.5mm) M3.5 Screw (Self-Lifting) M4 Screw (Self-Lifting) 115 2</p>	<p>MSOD-2xN21</p> <p>3-M4 Screw Mounting Hole 160 M4 Screw (Self-Lifting) 136 M3.5 Screw (Self-Lifting) 73 10.5 5 5 119 97 20.5 90 133 95.5 13.5 12.8 80 M4 Screw (Self-Lifting) 10.2 85 M3.5 Screw (Self-Lifting) 150 Reset Bar (Reset Stroke 2.5mm) Operation Indicator (Manual Tripping) 119 97 2</p>

S-T Series

MSOD-2xT35

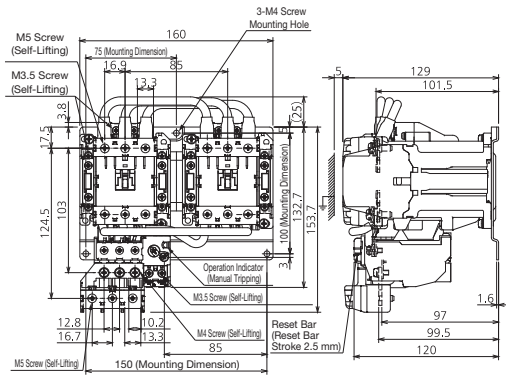

S-N Series

MSOD-2xN35

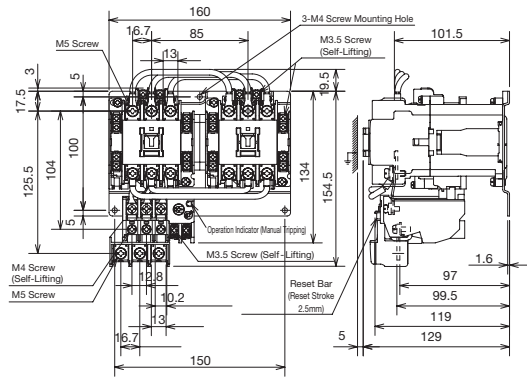

MSOD-2xT50

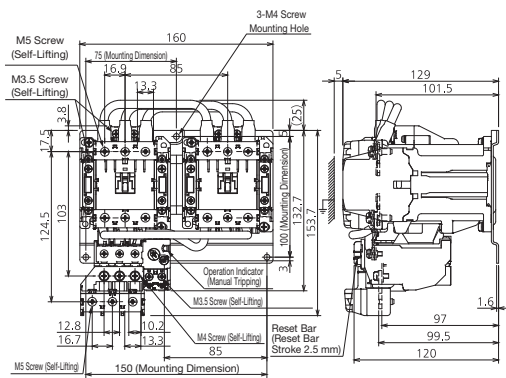

MSOD-2xN50

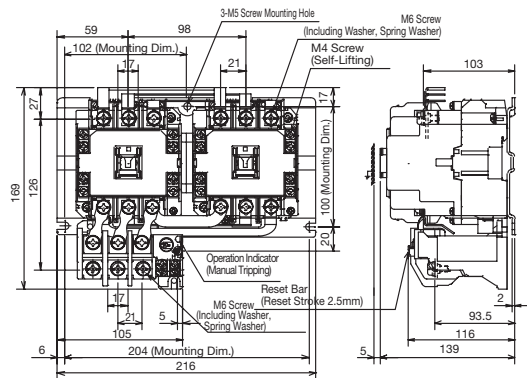

MSOD-2xT65

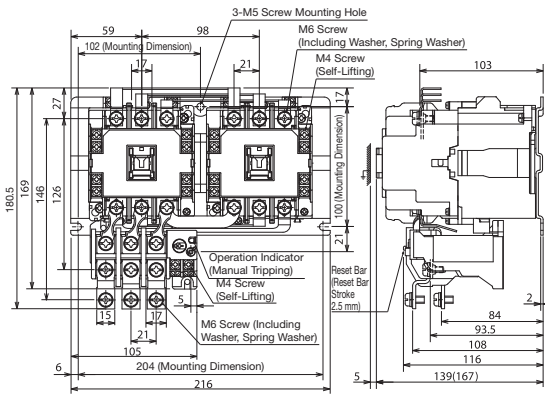

MSOD-2xN65

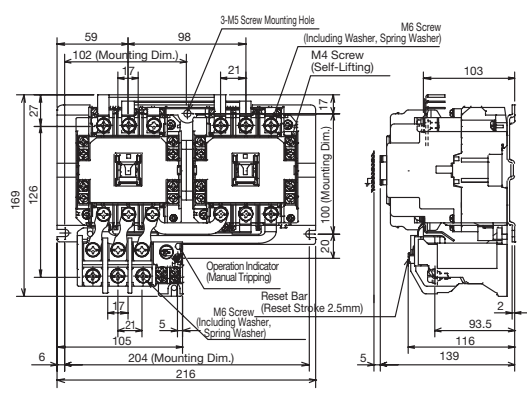

S-T Series

MSOD-2xT80

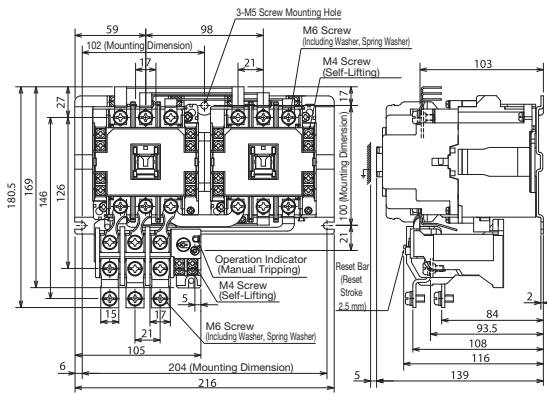

S-N Series

MSOD-2xN80

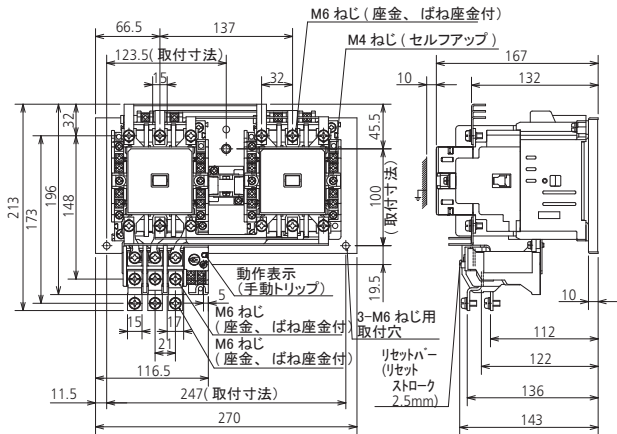

MSOD-2xT100

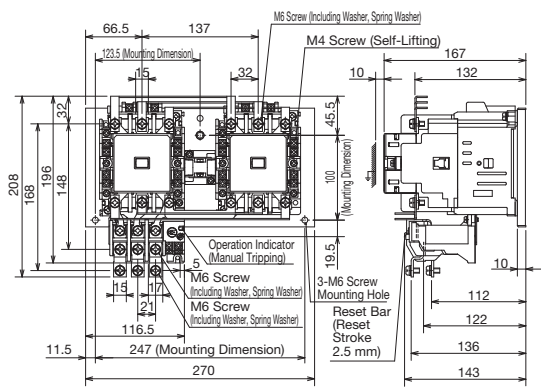

MSOD-2xN95

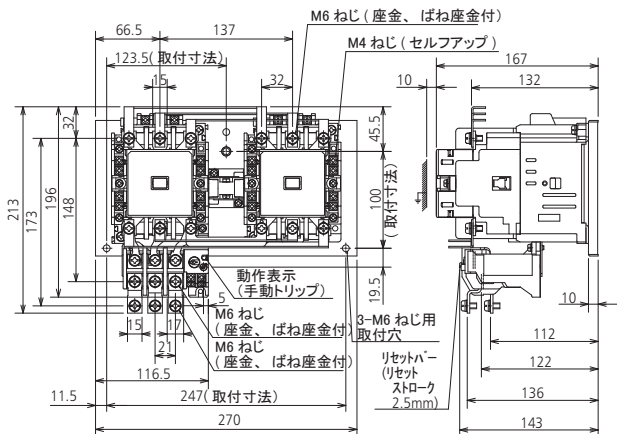

9.6 Magnetic Contactors (Reversing)

[AC Operated]

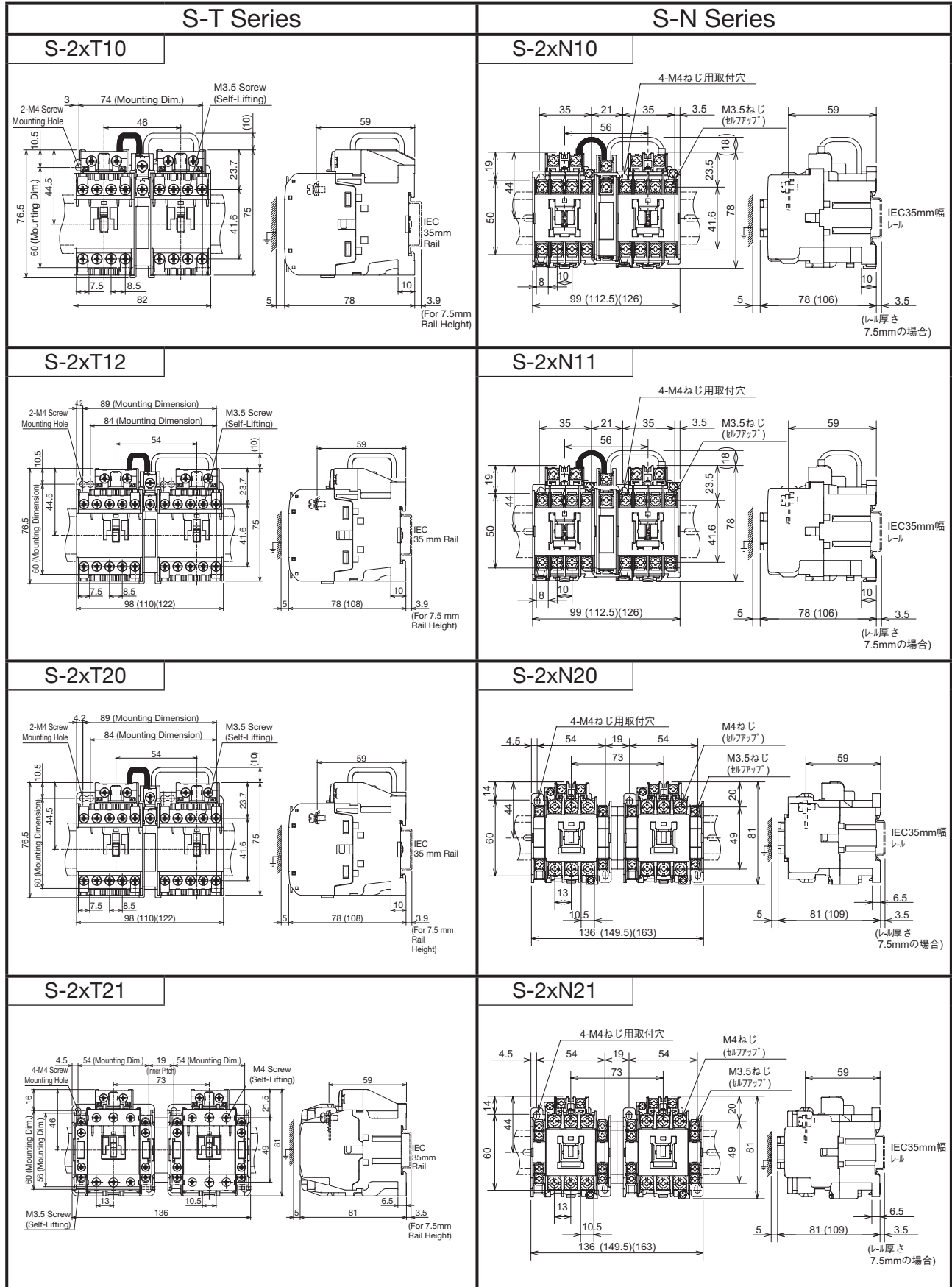

S-T Series

S-2xT25

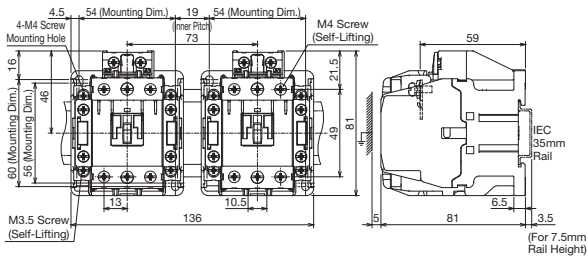

S-N Series

S-2xN25

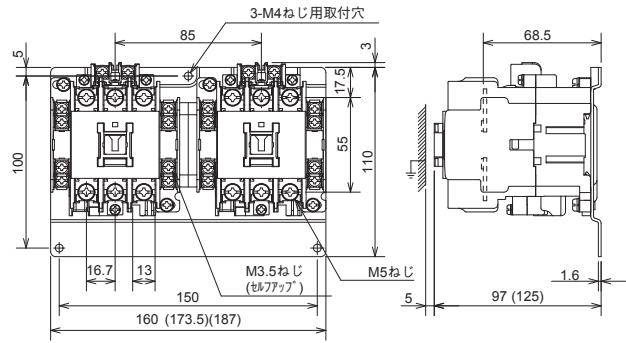

S-2xT32

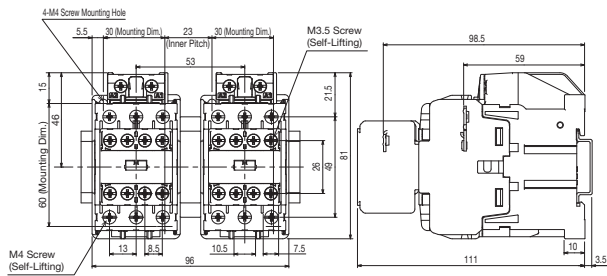

S-2xN18/N28

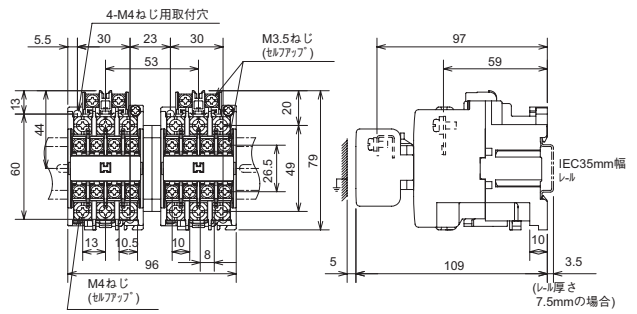

S-2xT35

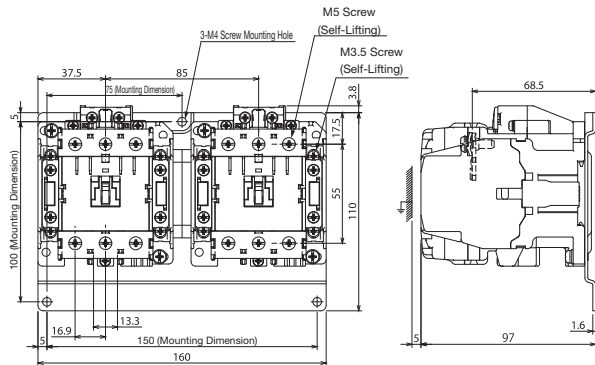

S-2xN35

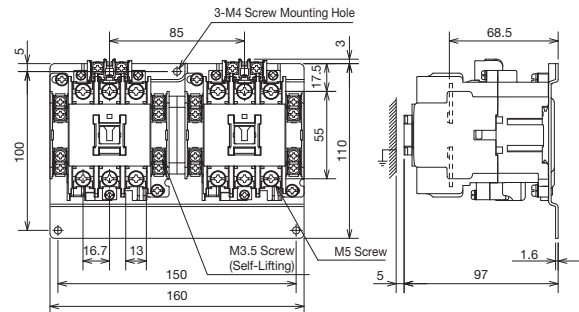

S-2xT50

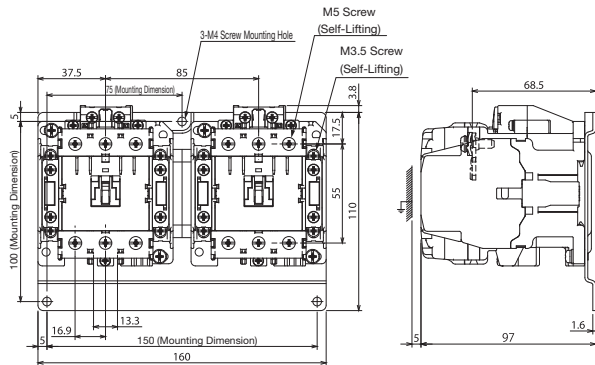

S-2xN50

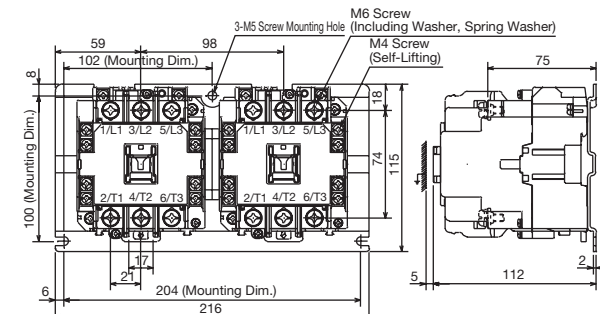

S-T Series

S-2xT65

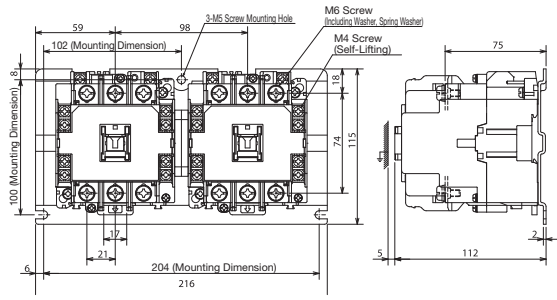

S-N Series

S-2xN65

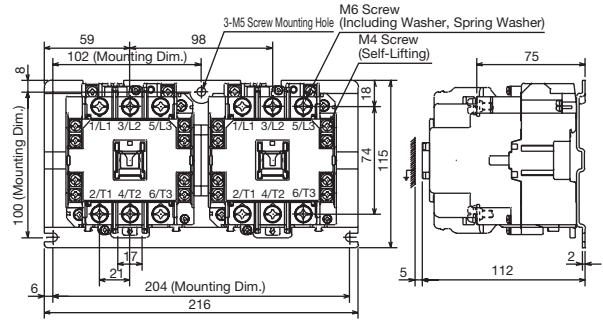

S-2xT80

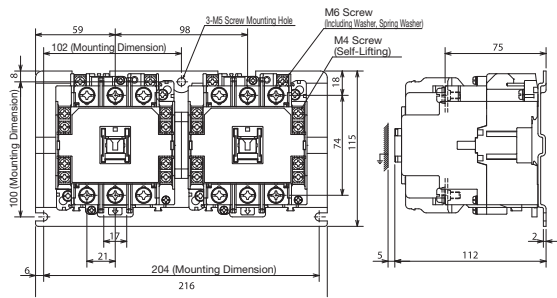

S-2xN80

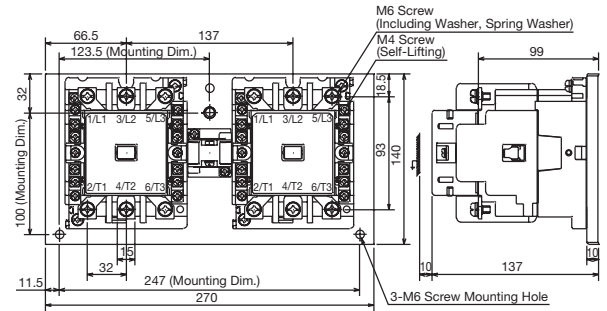

S-2xT100

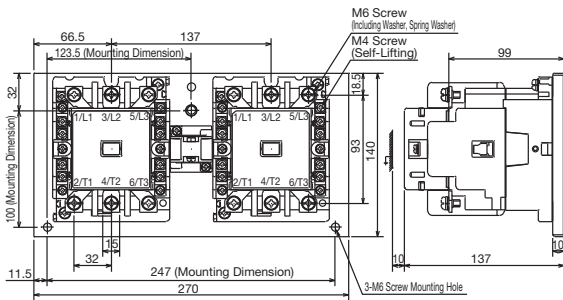

S-2xN95

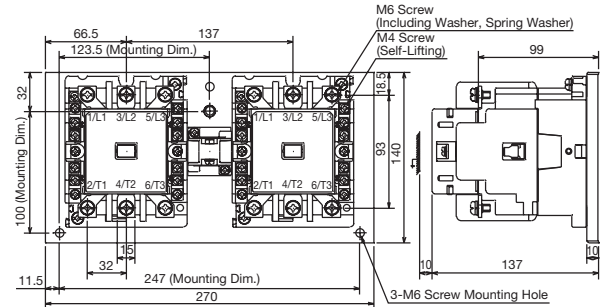

9.6 Magnetic Contactors (Reversing) [Continued]

[DC Operated]

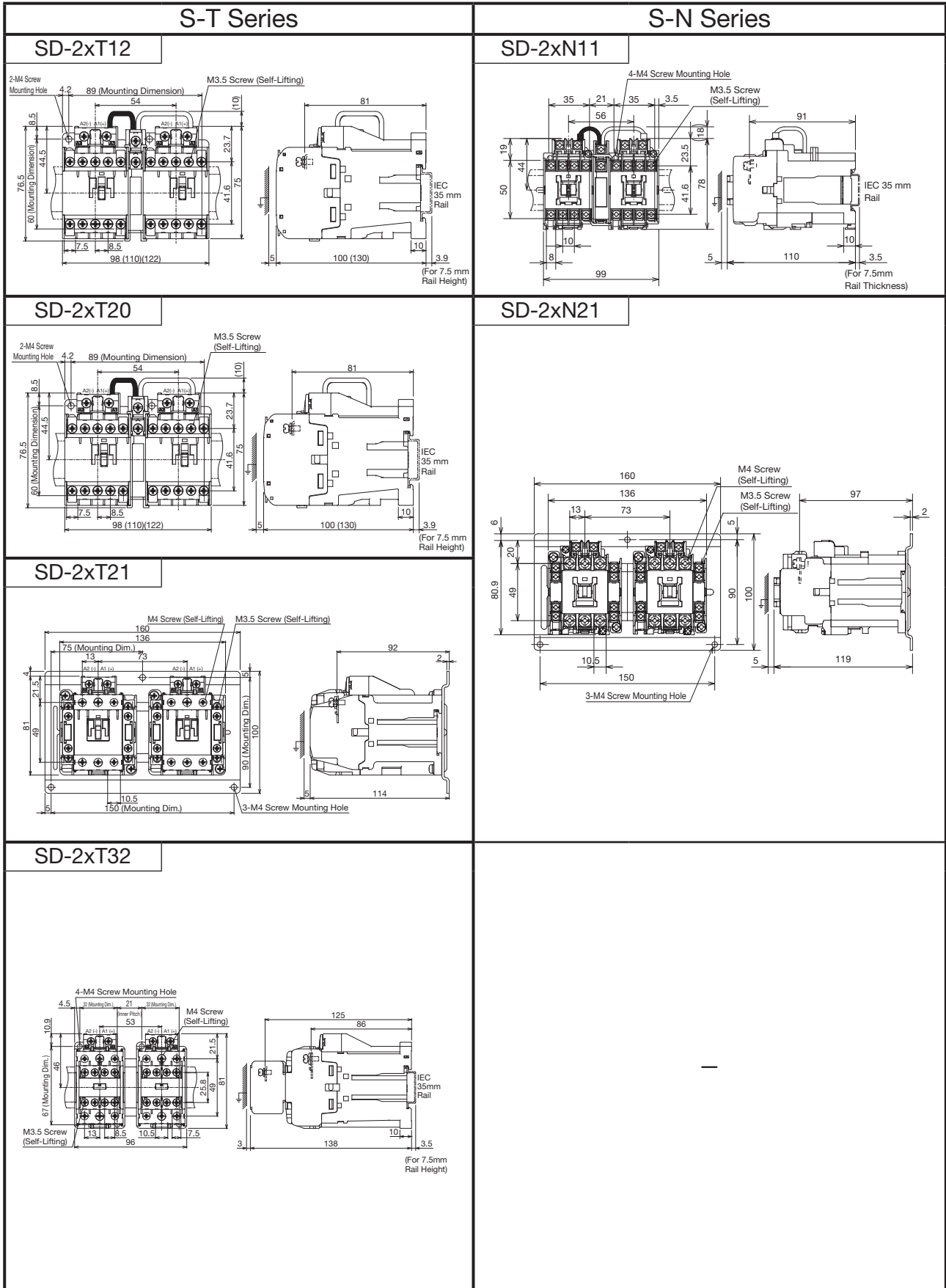

S-T Series

SD-2xT35

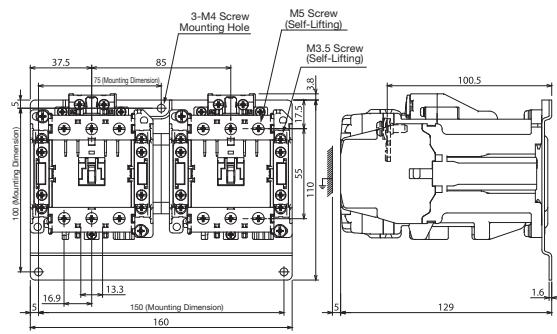

S-N Series

SD-2xN35

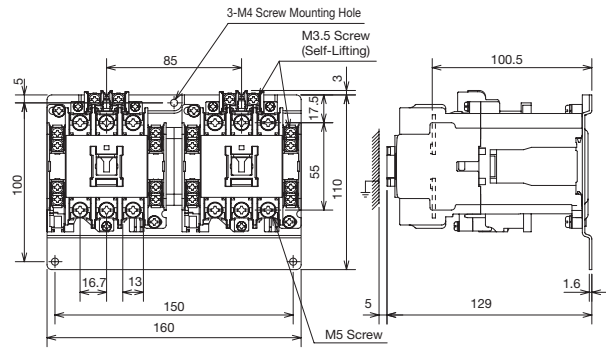

SD-2xT50

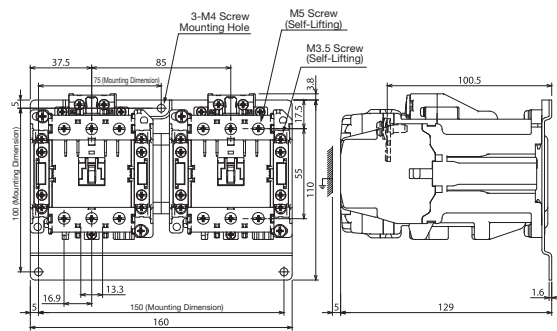

SD-2xN50

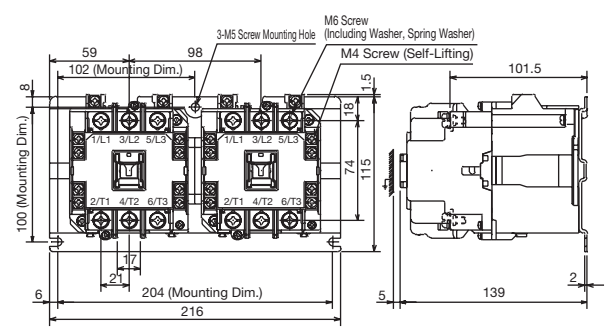

SD-2xT65

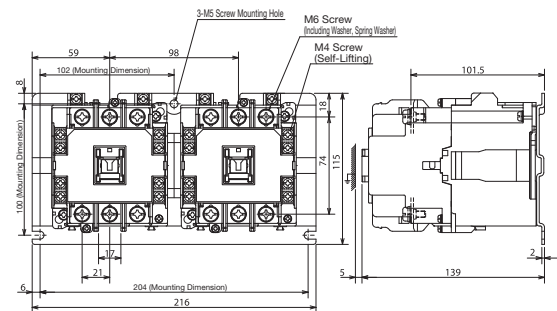

SD-2xN65

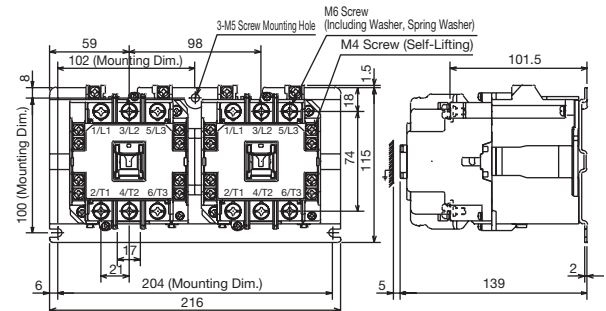

S-T Series

SD-2xT80

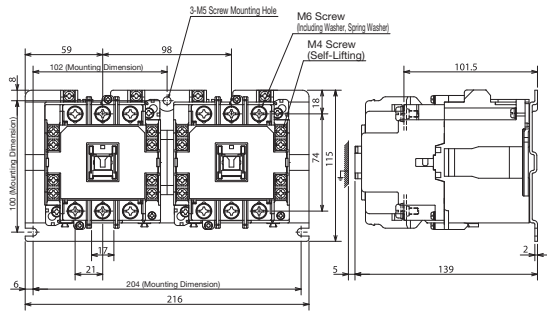

S-N Series

SD-2xN80

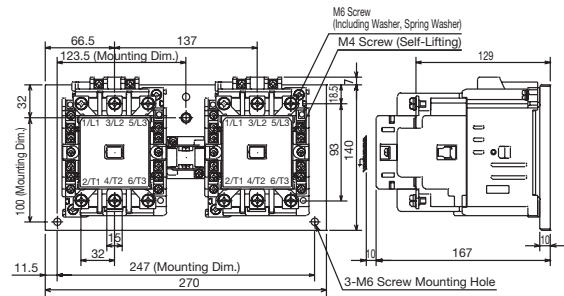

SD-2xT100

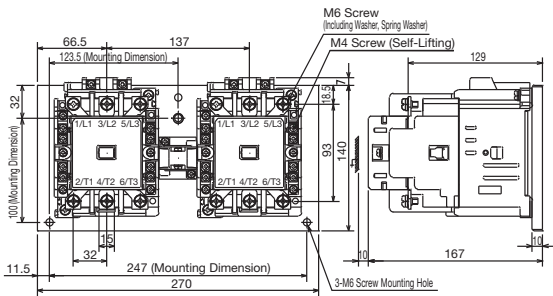

SD-2xN95

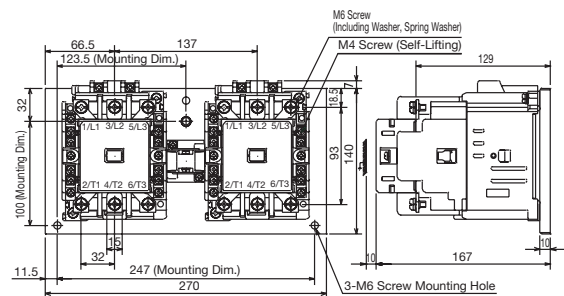

9.7 Thermal Overload Relays

TH-T Series	TH-N Series
<p>TH-T18</p> <p>Reset Bar (Reset Stroke 2.5mm)</p> <p>Operation Indicator (Manual Tripping)</p> <p>M3.5 Screw (Self-Lifting)</p> <p>Dimensions: 10.5, 24.5, 57, 14.5, 31.5, 59, 6, 7.1, 10, 8, 46, 76.5, 34.5</p>	<p>TH-N12</p> <p>Reset Bar (Reset Stroke 2.5mm)</p> <p>Operation Indicator (Manual Tripping)</p> <p>M3.5 Screw (Self-Lifting)</p> <p>Dimensions: 10.5, 24, 15, 31, 55, 6.5, 6, 10, 8, 45, 57, 35, 76.5</p>
<p>TH-T25</p> <p>Reset Bar (Reset Stroke 2.5mm)</p> <p>Operation Indicator (Manual Tripping)</p> <p>M3.5 Screw (Self-Lifting)</p> <p>M4 Screw (Self-Lifting)</p> <p>2-M4 Screw Mounting Hole</p> <p>Dimensions: 14.8, 19, 5, 63, 10.3, 11.1, 31.2, 51.3, 6.5, 22.8, 53, 18, 10.2, 12.8, 8, 7.5, 80, 57, 8</p>	<p>TH-N18</p> <p>リセット杆 (リセットストローク 2.5mm)</p> <p>動作表示 (手動トリップ)</p> <p>M4ねじ (セルフリフト)</p> <p>M3.5ねじ (セルフリフト)</p> <p>Dimensions: 10.5, 24.5, 16.3, 58.5, 6.7, 6, 12.5, 10.2, 8, 54, 32.5, 59, 80, 40, 8</p>
<p>TH-N20</p> <p>Reset Bar (Reset Stroke 2.5mm)</p> <p>Operation Indicator (Manual Tripping)</p> <p>M3.5 Screw (Self-Lifting)</p> <p>M4 Screw (Self-Lifting)</p> <p>2-M4 Screw Mounting Hole</p> <p>Dimensions: 19, 5, 63, 6.5, 33, 10.2, 12.8, 8, 63, 5.5, 21, 51, 18, 79, 57, 7</p>	<p>TH-N20TA (22A Designation)</p> <p>Operation Indicator (Manual Tripping)</p> <p>Reset Bar (Reset Stroke 2.5mm)</p> <p>M4 Screw (Self-Lifting)</p> <p>M5 Screw</p> <p>M3.5 Screw (Self-Lifting)</p> <p>Dimensions: 79, 63, 7, 5.5, 21, 39, 72, 5, 16.7, 13, 48, 74.3, 60, 83.5</p>

TH-T Series

TH-T50

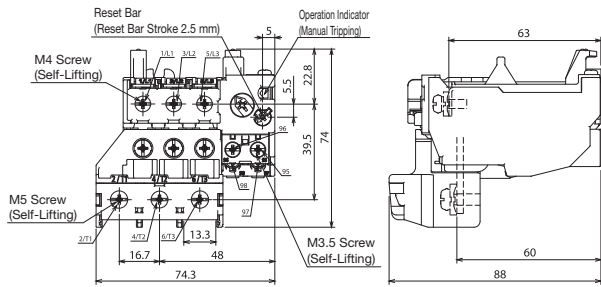

TH-N Series

TH-N20TA

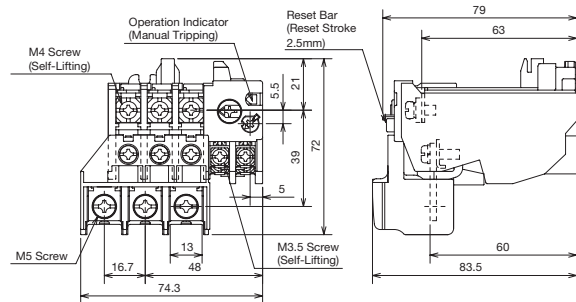

TH-T65

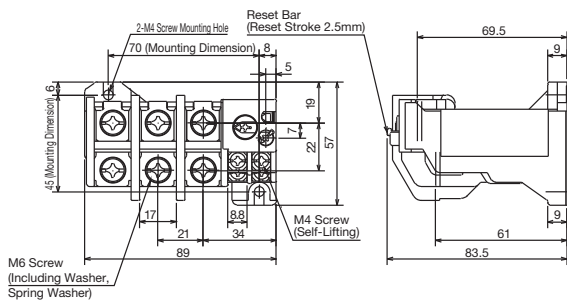

TH-N60

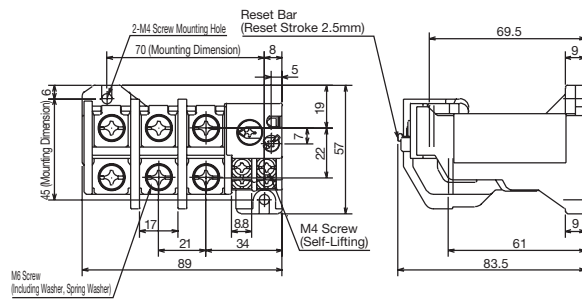

TH-T100

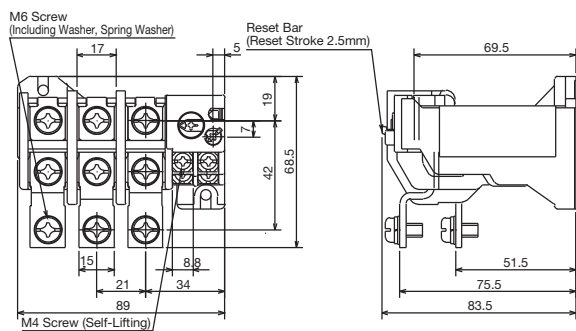

TH-N60TA

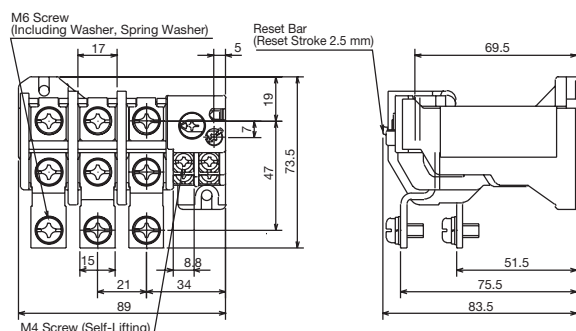

9.8 Contactor Relays

[AC Operated]

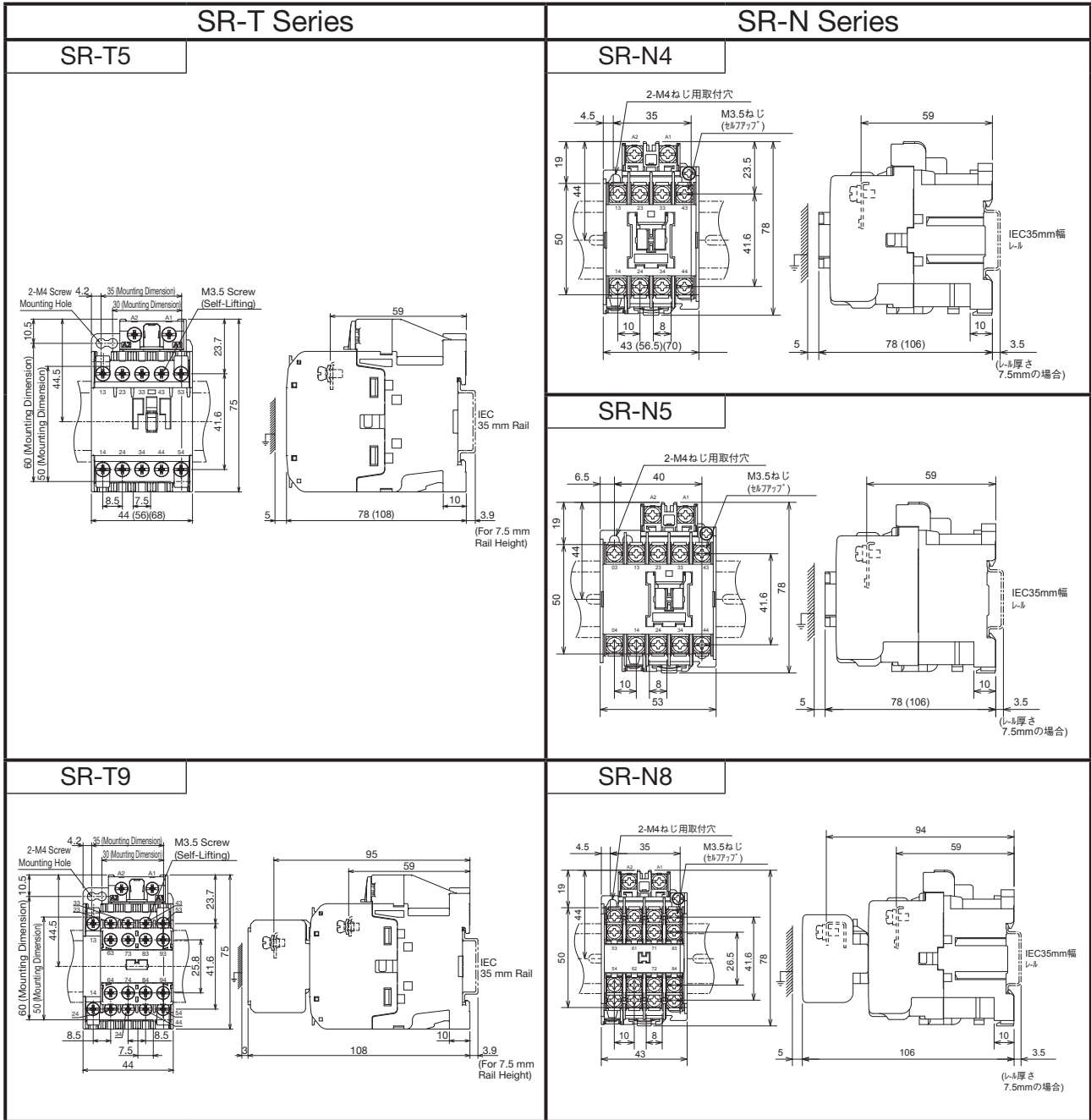

9.8 Contactor Relays

[DC Operated]

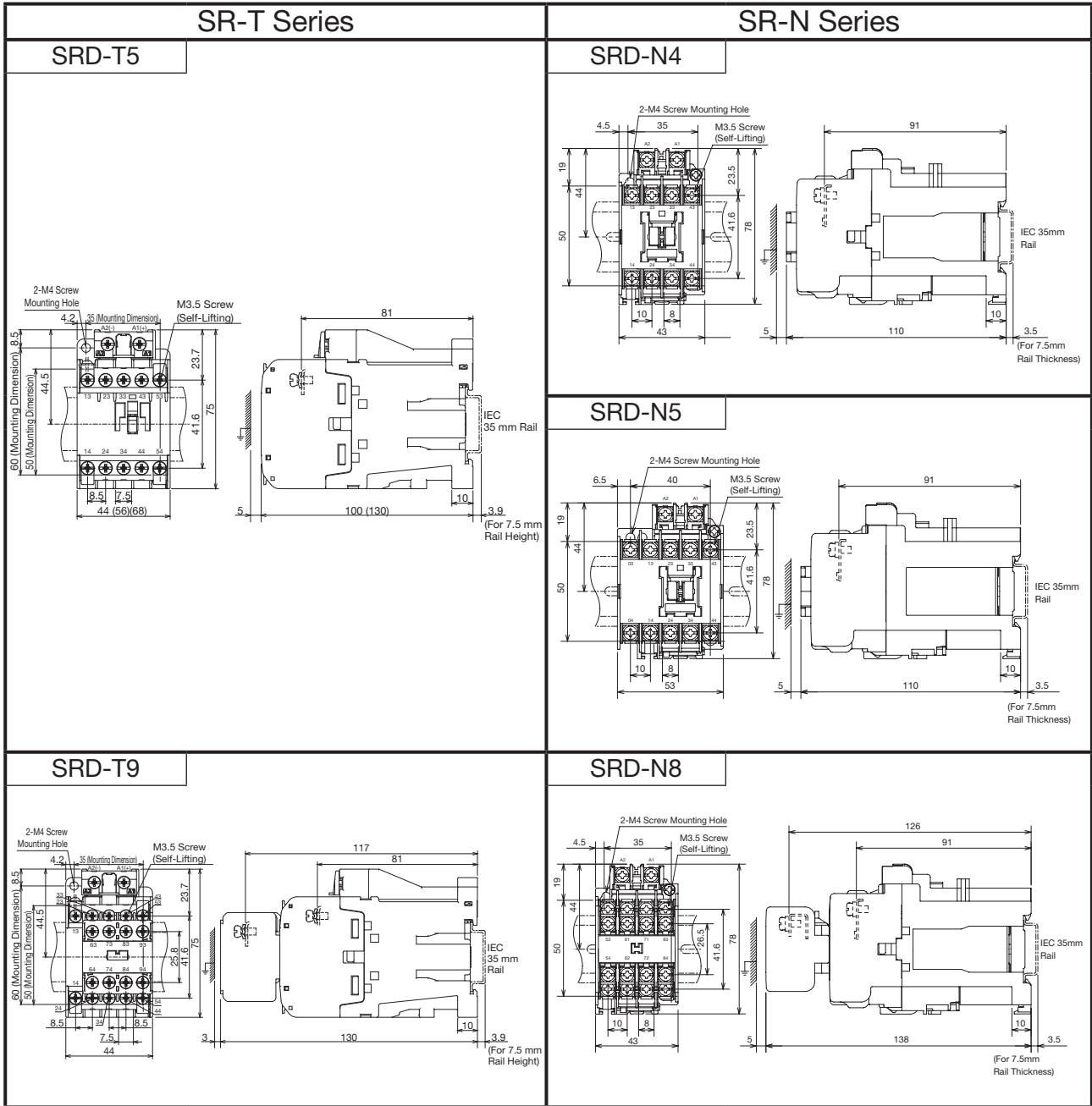

9.8 Contactor Relays

[Mechanically Latched Type]

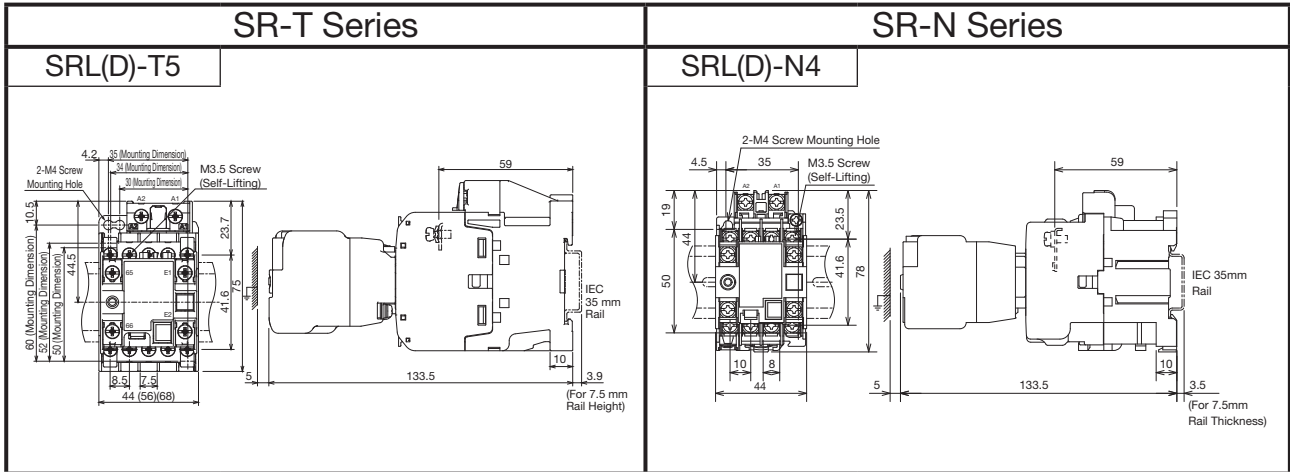

10. New and Old Model Comparison Table for Magnetic Starters/Magnetic Contactors/Contactor Relays

10.1 Magnetic Starters (Enclosed Type)

Model Name		MS-T10	MS-T12	MS-T21
Rated Capacity (kw/A) AC-3	200 - 220V	2.2/11	3.5/13	5.5/2.5
	380 - 440V	2.7/7	5.5/12	11/23
Auxiliary Contact Arrangement		1a	1a1b	2a2b
External Dimensions (mm)	W (Width)	76		104
	H (Height)	165		176
	D (Depth)	97.5		110
	E x F (Mounting)	45 x 120		76 x 140
Mounting Compatibility with MS-N Series		○	○	○

Model Name		MS-N10	MS-N11	MS-N12	MS-N20	MS-N21
Rated Capacity (kw/A) AC-3	200 - 220V	2.2/11	2.7/13	2.7/13	3.7/18	3.7/18
	380 - 440V	2.7/7	4/9	4/9	7.5/18	7.5/18
Auxiliary Contact Arrangement		1a	1a	1a1b	1a1b	2a2b
External Dimensions (mm)	W (Width)	76		104		
	H (Height)	165		176		
	D (Depth)	97.5		110		
	E x F (Mounting)	45 x 120		76 x 140		

Note 1. Exterior, Mounting Holes

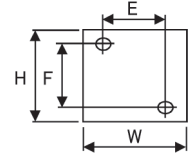

Note 2. Mounting Compatibility

- : Compatible
- △ : Compatible with Adapter

Model Name		MS-T35	MS-T50	MS-T65	MS-T80	MS-T100
Rated Capacity (kw/A) AC-3	200 - 220V	11/40	15/55	18.5/65	22/85	30/105
	380 - 440V	18.5/40	22/48	30/65	45/85	55/105
Auxiliary Contact Arrangement		2a2b	2a2b	2a2b	2a2b	2a2b
External Dimensions (mm)	W (Width)	135		160		190
	H (Height)	231		282		317
	D (Depth)	126		145		163
	E x F (Mounting)	95 x 165		120 x 220		150 x 260
Mounting Compatibility with MS-N Series		○	○	x	○	x

Model Name		MS-N25	MS-N35	MS-N50	MS-N65	MS-N80	MS-N95
Rated Capacity (kw/A) AC-3	200 - 220V	5.5/26	7.5/34	11/50	15/65	19/80	22/100
	380 - 440V	11/25	15/32	22/48	30/65	37/80	45/93
Auxiliary Contact Arrangement		2a2b	2a2b	2a2b	2a2b	2a2b	2a2b
External Dimensions (mm)	W (Width)	135		160		190	
	H (Height)	231		282		317	
	D (Depth)	126		145		163	
	E x F (Mounting)	95 x 165		120 x 220		150 x 260	

10.2 Magnetic Starters (Open Type)

[AC Operated]

Model Name		MSO-T10	MSO-T12		MSO-T20		MSO-T21		MSO-T25
Rated Capacity (kw/A) AC-3	200 - 220V	2.5/11	3.5/13		4.5/18		5.5/25		7.5/30
	380 - 440V	4/9	5.5/12		7.5/18		11/23		15/30(26)
Auxiliary Contact Arrangement		1a	1a1b			2a2b		2a2b	
External Dimensions (mm)	W (Width)	46	46		46		63		63
	H (Height)	115	115		115		128		128
	D (Depth)	79	79		79		82		82
	E x F (Mounting)	28 x 60	35 x 60, 30 x 60 35 x 50 - 52, 34 x 52		35 x 60, 30 x 60 35 x 50 - 52, 34 x 52		54 x 60 54 x 56		54 x 60 54 x 56
Mounting Compatibility with MS-N Series		△ (35 x 50, 34 x 52)	○	△ (40 x 50)	○	△ (54 x 60, 54 x 56)	○	○	△ (65 x 70, 60 x 70)
Model Name		MSO-N10	MSO-N11	MSO-N12	MSO-N18	MSO-N20		MSO-N21	MSO-N25
Rated Capacity (kw/A) AC-3	200 - 220V	2.2/11	2.7/13	2.7/13	3.7/18	4/18		4/18	5.5/26
	380 - 440V	2.7/7	4/9	4/9	5.5/13	7.5/18		7.5/18	11/25
Auxiliary Contact Arrangement		1a	1a	1a1b	-	1a1b		2a2b	2a2b
External Dimensions (mm)	W (Width)	45		55	54	63		63	75
	H (Height)	115		115	122	127		127	136.5 (- 15A Designation) 157.5 (22A Designation)
	D (Depth)	79		79	81	81		81	91
	E x F (Mounting)	35 x 50, 30 x 48 30 x 52, 34 x 52		40 x 50 40 x 52 34 x 48 - 52	30 x 60, 35 x 50 32 x 52, 34 x 52	54 x 60, 54 x 56		54 x 60 54 x 56	65 x 70 60 x 70

Model Name		MSO-T35	MSO-T50	MSO-T65	MSO-T80	MSO-T100	
Rated Capacity (kw/A) AC-3	200 - 220V	11/40	15/55	18.5/65	22/85	30/105	
	380 - 440V	18.5/40	22/48	30/65	45/85	55/105	
Auxiliary Contact Arrangement		2a2b	2a2b	2a2b	2a2b	2a2b	
External Dimensions (mm)	W (Width)	75	75	90	90	100	
	H (Height)	157.5	157.5	158	158	191	
	D (Depth)	91	91	106	106	127	
	E x F (Mounting)	65 x 70 60 x 70	65 x 70 60 x 70	70 x 75	70 x 75	80 x 110	
Mounting Compatibility with MS-N Series		○	△ (70 x 75)	○	△ (80 x 110)	○	
Model Name		MSO-N35	MSO-N50	MSO-N65	MSO-N80	MSO-N95	
Rated Capacity (kw/A) AC-3	200 - 220V	7.5/34	11/50	15/65	19/80	22/100	
	380 - 440V	15/32	22/48	30/65	37/80	45/93	
Auxiliary Contact Arrangement		2a2b	2a2b	2a2b	2a2b	2a2b	
External Dimensions (mm)	W (Width)	75	90	90	100	100	
	H (Height)	157.5	158	158	196	196	
	D (Depth)	91	106	106	127	127	
	E x F (Mounting)	65 x 70 60 x 70	70 x 75	70 x 75	80 x 110	80 x 110	

[DC Operated]

Model Name		MSOD-T12	MSOD-T20	MSOD-T21
Rated Capacity (kw/A)	200 - 220V	3.5/13	4.5/18	5.5/25
	380 - 440V	5.5/12	7.5/18	11/23
AC-3				
Auxiliary Contact Arrangement		1a1b	1a1b	2a2b
External Dimensions (mm)	W (Width)	46	46	63
	H (Height)	115	115	128
	D (Depth)	101	101	109
	E x F (Mounting)	35 x 60, 34 x 52 35 x 50 - 52	35 x 60, 34 x 52 35 x 50 - 52	54 x 56 - 60
Mounting Compatibility with MS-N Series		○	△ (40 x 50)	○

Model Name		MSOD-N11	MSOD-N12	MSOD-N21
Rated Capacity (kw/A)	200 - 220V	2.7/13	2.7/13	4/18
	380 - 440V	4/9	4/9	7.5/18
AC-3				
Auxiliary Contact Arrangement		1a	1a1b	2a2b
External Dimensions (mm)	W (Width)	45	55	63
	H (Height)	116	116	127
	D (Depth)	111	111	113
	E x F (Mounting)	35 x 50, 30 x 48 30 x 52, 34 x 52	40 x 50 40 x 52 34 x 48 - 52	54 x 60 54 x 56

Note 1. Exterior, Mounting Holes

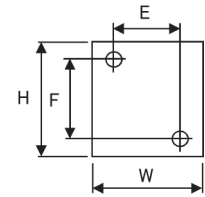

Note 2. Mounting Compatibility

○ : Compatible

△ : Compatible with Adapter

Model Name		MSOD-T35	MSOD-T50	MSOD-T65	MSOD-T80	MSOD-T100
Rated Capacity (kw/A)	200 - 220V	11/40	15/55	18.5/65	22/85	30/105
	380 - 440V	18.5/40	22/48	30/65	45/85	55/105
AC-3						
Auxiliary Contact Arrangement		2a2b	2a2b	2a2b	2a2b	2a2b
External Dimensions (mm)	W (Width)	75	75	90	90	100
	H (Height)	157.5	157.5	160	160	201
	D (Depth)	123	123	133	133	157
	E x F (Mounting)	65 x 70 60 x 70	65 x 70 60 x 70	70 x 75	70 x 75	80 x 110
Mounting Compatibility with MS-N Series		○	△	○	△	○

Model Name		MSOD-N35	MSOD-N50	MSOD-N65	MSOD-N80	MSOD-N95
Rated Capacity (kw/A)	200 - 220V	7.5/34	11/50	15/65	19/80	22/100
	380 - 440V	15/32	22/48	30/65	37/80	45/93
AC-3						
Auxiliary Contact Arrangement		2a2b	2a2b	2a2b	2a2b	2a2b
External Dimensions (mm)	W (Width)	75	90	90	100	100
	H (Height)	157.5	161.5	161.5	206	206
	D (Depth)	123	133	133	157	157
	E x F (Mounting)	65 x 70 60 x 70	70 x 75	70 x 75	80 x 110	80 x 110

10.3 Magnetic Contactors

[AC Operated]

Model Name		S-T10	S-T12	S-T20	S-T21	S-T25	S-T35	S-T32
Rated Capacity (kw/A) AC-3 (Motor Load)	200 - 220V	2.5/11	3.5/13	4.5/18	5.5/25	8.5/30	11/40	7.5/32
	380 - 440V	4/9	5.5/12	7.5/18	11/23	15/30(26)	13.5/40	15/32
Rating (A) AC-1 (Resistance Load)	100 - 240V	20	20	20	32	32	60	32
	380 - 440V	11	13	13	32	32	60	32
Conventional Free Air Thermal Current (A)		20	20	20	32	32	60	32
Auxiliary Contact Arrangement		1a	1a1b		2a2b	2a2b	2a2b	-
External Dimensions (mm)	W (Width)	36	44	44	63	63	75	43
	H (Height)	75	75	75	81	81	89	81
	D (Depth)	78	78	78	81	81	91	81
	E x F (Mounting)	28 x 60	35 x 60, 30 x 60 35 x 50 - 52, 34 x 52	35 x 60, 30 x 60 35 x 50 - 52, 34 x 52	54 x 60 54 x 56	54 x 60 54 x 56	65 x 70 60 x 70	30 x 60
Mounting Compatibility with MS-N Series		△ (35 x 50, 34 x 52)	○	△ (40 x 50)	○	○	△ (65 x 70, 60 x 70)	○

Model Name		S-N10	S-N11	S-N12	S-N18	S-N20 (Motor Load/Resistance Load)	S-N20 (Resistance Load)	S-N21	S-N25 (Motor Load/Resistance Load)	S-N25 (Resistance Load)	S-N18	S-N28
Rated Capacity (kw/A)	200 - 220V	2.2/11	2.7/13	2.7/13	3.7/18	4/20	4/20	4/20	5.5/26	5.5/26	3.7/18	5.5/26
	380 - 440V	2.7/7	4/9	4/9	5.5/13	7.5/20	7.5/20	7.5/20	11/25	11/25	5.5/13	7.5/17
Rating (A) AC-1 (Resistance Load)	100 - 220V	20	20	20	25	32	32	32	50	50	25	30
	400 - 440V	11	13	13	20	32	32	32	50	50	20	30
Conventional Free Air Thermal Current (A)		20	20	20	25	32	32	32	50	50	25	30
Auxiliary Contact Arrangement		1a	1a	1a1b	-	1a1b	2a2b	2a2b	2a2b	2a2b	-	-
External Dimensions (mm)	W (Width)	43	53	43	63	63	63	75	43	43		
	H (Height)	78	78	79	81	81	81	89	79	79		
	D (Depth)	78	78	81	81	81	81	91	81	81		
	E x F (Mounting)	35 x 50, 30 x 48 30 x 52, 34 x 52	40 x 50, 40 x 52 34 x 48 - 52	30 x 60, 35 x 50 32 x 52, 34 x 52	54 x 60, 54 x 56	54 x 60 54 x 56	65 x 70 60 x 70	30 x 60, 35 x 50 32 x 52, 34 x 52				

Model Name		S-T35	S-T50	S-T65	S-T80	S-T100
Rated Capacity (kw/A)	200 - 220V	11/40	15/55	18.5/65	22/85	30/105
	380 - 440V	18.5/40	22/48	30/65	45/85	55/105
AC-3						
Rating (A) AC-1 (Resistance Load)		60	80	100	120	150
Conventional Free Air Thermal Current (A)		60	80	100	120	150
Auxiliary Contact Arrangement		2a2b	2a2b	2a2b	2a2b	2a2b
External Dimensions (mm)	W (Width)	75	75	88	88	100
	H (Height)	89	89	106	106	124
	D (Depth)	91	91	106	106	127
	E x F (Mounting)	65 x 70 60 x 70	65 x 70 60 x 70	70 x 75	70 x 75	80 x 110
Mounting Compatibility with MS-N Series		○	△ (70 x 75)	○	△ (80 x 110)	○

Model Name		S-N35	S-N50	S-N65	S-N80 (Motor Load/Resistance Load)	S-N80 (Resistance Load)	S-N95
Rated Capacity (kw/A)	200 - 220V	7.5/34	11/50	15/65	19/80	19/80	22/100
	380 - 440V	15/32	22/48	30/65	37/80	37/80	45/93
AC-3							
Rating (A) AC-1 (Resistance Load)		60	80	100	135	135	150
Conventional Free Air Thermal Current (A)		60	80	100	135	135	150
Auxiliary Contact Arrangement		2a2b	2a2b	2a2b	2a2b	2a2b	2a2b
External Dimensions (mm)	W (Width)	75	88	88	100	100	100
	H (Height)	89	106	106	124	124	124
	D (Depth)	91	106	106	127	127	127
	E x F (Mounting)	65 x 70 60 x 70	70 x 75	70 x 75	80 x 110	80 x 110	

[DC Operated]

Model Name		SD-T12	SD-T20	SD-T21	SD-T32
Rated Capacity (kw/A) AC-3 (Motor Load)	200 - 220V	3.5/13	4.5/18	5.5/25	7.5/32
	380 - 440V	5.5/12	7.5/18	11/23	15/32
Rating (A) AC-1 (Resistance Load)	100 - 240V	20	20	32	32
	380 - 440V	13	13	32	32
Conventional Free Air Thermal Current (A)		20	20	32	32
Auxiliary Contact Arrangement		1a1b	1a1b	2a2b	-
External Dimensions (mm)	W (Width)	44	44	63	43
	H (Height)	75	75	81	81
	D (Depth)	100	100	108	108
	E x F (Mounting)	35 x 60, 34 x 52 35 x 50 - 52	35 x 60, 34 x 52 35 x 50 - 52	54 x 60 54 x 56	32 x 67
Mounting Compatibility with MS-N Series		○	△ (40 x 50)	○	○

Model Name		SD-N11	SD-N12	SD-N21 (Motor Load/Resistance Load)	SD-N21 (Resistance Load)	-
Rated Capacity (kw/A) AC-3	200 - 220V	2.7/13	2.7/13	4/20	4/20	-
	380 - 440V	4/9	4/9	7.5/20	7.5/20	-
Rating (A) AC-1 (Resistance Load)	100 - 220V	20	20	32	32	-
	400 - 440V	13	13	32	32	-
Conventional Free Air Thermal Current (A)		20	20	32	32	-
Auxiliary Contact Arrangement		1a	1a1b	2a2b	2a2b	-
External Dimensions (mm)	W (Width)	43	53	63	63	-
	H (Height)	78	78	81	81	-
	D (Depth)	110	110	113	113	-
	E x F (Mounting)	35 x 50, 30 x 48 30 x 52, 34 x 52	40 x 50, 40 x 52 34 x 48 - 52	54 x 60, 54 x 56	54 x 60 54 x 56	-

Note 1. Exterior, Mounting Holes

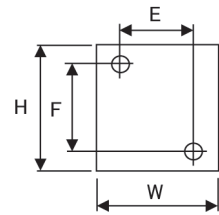

Note 2. Mounting Compatibility

- : Compatible
- △ : Compatible with Adapter

Model Name		SD-T35	SD-T50	SD-T65	SD-T80	SD-T100
Rated Capacity (kw/A) AC-3	200 - 220V	11/40	15/55	18.5/65	22/85	30/105
	380 - 440V	18.5/40	22/48	30/65	45/85	55/105
Rating (A) AC-1 (Resistance Load)	100 - 240V	60	80	100	120	150
	380 - 440V	60	80	100	120	150
Conventional Free Air Thermal Current (A)		60	80	100	120	150
Auxiliary Contact Arrangement		2a2b	2a2b	2a2b	2a2b	2a2b
External Dimensions (mm)	W (Width)	75	75	88	88	100
	H (Height)	89	89	106	106	124
	D (Depth)	123	123	133	133	157
	E x F (Mounting)	65 x 70 60 x 70	65 x 70 60 x 70	70 x 75	70 x 75	80 x 110
Mounting Compatibility with MS-N Series		○	△ (70 x 75)	○	△ (80 x 110)	○

Model Name		SD-N35	SD-N50	SD-N65	SD-N80 (Motor Load/Resistance Load)	SD-N80 (Resistance Load)	SD-N95
Rated Capacity (kw/A) AC-3	200 - 220V	7.5/34	11/50	15/65	19/80	19/80	22/100
	380 - 440V	15/32	22/48	30/65	37/80	37/80	45/93
Rating (A) AC-1 (Resistance Load)	100 - 220V	60	80	100	135	135	150
	400 - 440V	60	80	100	135	135	150
Conventional Free Air Thermal Current (A)		60	80	100	135	135	150
Auxiliary Contact Arrangement		2a2b	2a2b	2a2b	2a2b	2a2b	2a2b
External Dimensions (mm)	W (Width)	75	88	88	100	100	100
	H (Height)	89	106	106	124	124	124
	D (Depth)	123	133	133	157	157	157
	E x F (Mounting)	65 x 70 60 x 70	70 x 75	70 x 75	80 x 110	80 x 110	80 x 110

[Mechanically Latched Type]

Model Name		SL(D)-T21	SL(D)-T35	SL(D)-T50 ^{Note 1}	SL(D)-T65	SL(D)-T80	SL(D)-T100
Rated Capacity (kw/A) AC-3	200 - 220V	5.5/25	11/40	15/55	18.5/65	22/85	30/105
	380 - 440V	11/23	15/40	22/48	30/65	45/85	55/105
Rating (A) AC-1 (Resistance Load)	100 - 240V	32	60	80	100	120	150
	380 - 440V	32	60	80	100	120	150
Conventional Free Air Thermal Current (A)		32	60	80	100	120	150
Auxiliary Contact Arrangement	Valid	2a2b	2a2b	2a2b	2a2b	2a2b	1a2b
	For Self-Demagnetization	1a1b	1a1b	1a1b	1a1b	1a1b	1a1b
External Dimensions (mm)	W (Width)	63	75	75	88	88	100
	H (Height)	81	89	89	106	106	124
	D (Depth)	136.5	145.5	145.5	135.5	135.5	127
	E x F (Mounting)	54 x 60 54 x 56	65 x 70 60 x 70	65 x 70 60 x 70	70 x 75	70 x 75	80 x 110
Mounting Compatibility with MS-N Series		○	○	△ (70 x 75)	○	△ (80 x 110)	○

Model Name		SL(D)-N21	SL(D)-N35	SL(D)-N50	SL(D)-N65	SL(D)-N80 (Motor Load/Resistance Load)	SL(D)-N80 (Resistance Load)	SL(D)-N95
Rated Capacity (kw/A) AC-3	200 - 220V	4/20	7.5/34	11/50	15/65	19/80	19/80	22/100
	380 - 440V	7.5/20	15/32	22/48	30/65	37/80	37/80	45/93
Rating (A) AC-1 (Resistance Load)	100 - 220V	32	60	80	100	135	135	150
	400 - 440V	32	60	80	100	135	135	150
Conventional Free Air Thermal Current (A)		32	60	80	100	135	135	150
Auxiliary Contact Arrangement	Valid	2a2b	2a2b	2a2b	2a2b	1a2b	1a2b	1a2b
	For Self-Demagnetization	1a1b	1a1b	1a1b	1a1b	1a1b	1a1b	1a1b
External Dimensions (mm)	W (Width)	63	75	88	88	100	100	100
	H (Height)	81	89	106	106	124	124	124
	D (Depth)	136.5	146.5	135.5	135.5	127	127	127
	E x F (Mounting)	54 x 60 54 x 56	65 x 70 60 x 70	70 x 75	70 x 75	80 x 110	80 x 110	80 x 110

Note 1. SL(D)-T50 (Standard Product) and SL(D)-T50FN (Class 2 Heat-Resistant Type) external dimensions are different.

See Section 1 (Comparison of New and Old Specifications) or Section 10 (Outline Drawing) for details.

10.4 Contactor Relays

[AC Operated]

Model Name		SR-T5	SR-T9
Rated Operating Current (A) AC-15	220 VAC	3	3
	440 VAC	1.5	1.5
Conventional Free Air Thermal Current (A)		10	10
No. of Contacts		5	9
External Dimensions (mm)	W (Width)	44	44
	H (Height)	75	75
	D (Depth)	78	108
	E x F (Mounting)	35 x 60, 30 x 60 35 x 50 - 52	35 x 60, 30 x 60 35 x 50 - 52
Mounting Compatibility with MS-N Series		○	△ (40 x 50)

Model Name		SR-N4	SR-N5	SR-N8
Rated Operating Current (A) AC-15	220 VAC	3	3	3
	440 VAC	1.5	1.5	1.5
Conventional Free Air Thermal Current (A)		10	10	10
No. of Contacts		4	5	8
External Dimensions (mm)	W (Width)	43	53	43
	H (Height)	78	78	78
	D (Depth)	78	78	106
	E x F (Mounting)	35 x 50, 30 x 48 30 x 52, 34 x 52	40 x 50, 40 x 52 34 x 48 - 52	35 x 50, 30 x 48 30 x 52, 34 x 52

Note 1. Exterior, Mounting Holes

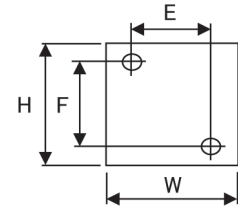

Note 2. Mounting Compatibility

- : Compatible
- △: Compatible with Adapter

[DC Operated]

Model Name		SRD-T5	SRD-T9
Rated Operating Current (A) AC-15	220 VAC	3	3
	440 VAC	1.5	1.5
Conventional Free Air Thermal Current (A)		10	10
No. of Contacts		5	9
External Dimensions (mm)	W (Width)	44	44
	H (Height)	75	75
	D (Depth)	100	130
	E x F (Mounting)	35 x 60, 34 x 52 35 x 50 - 52	35 x 60, 34 x 52 35 x 50 - 52
Mounting Compatibility with MS-N Series		○	△ (40 x 50)

Model Name		SRD-N4	SRD-N5	SRD-N8
Rated Operating Current (A) AC-15	220 VAC	3	3	3
	440 VAC	1.5	1.5	1.5
Conventional Free Air Thermal Current (A)		10	10	10
No. of Contacts		4	5	8
External Dimensions (mm)	W (Width)	43	53	43
	H (Height)	78	78	78
	D (Depth)	110	110	138
	E x F (Mounting)	35 x 50, 30 x 48 30 x 52, 34 x 52	40 x 50, 40 x 52 34 x 48 - 52	35 x 50, 30 x 48 30 x 52, 34 x 52

[Mechanically Latched Type]

Model Name		SRL(D)-T5
Rated Operating Current (A) AC-15	220 VAC	3
	440 VAC	1.5
Conventional Free Air Thermal Current (A)		10
No. of Contacts		5
External Dimensions (mm)	W (Width)	44
	H (Height)	75
	D (Depth)	133.5
	E x F (Mounting)	35 x 60, 34 x 52 35 x 50 - 52
Mounting Compatibility with MS-N Series		○

Model Name		SRL(D)-N4
Rated Operating Current (A) AC-15	220 VAC	3
	440 VAC	1.5
Conventional Free Air Thermal Current (A)		10
No. of Contacts		4
External Dimensions (mm)	W (Width)	43
	H (Height)	78
	D (Depth)	133.5
	E x F (Mounting)	35 x 50, 30 x 48 30 x 52, 34 x 52

MEMO

Motor circuit breakers

Safety Warning

To ensure proper use of the products listed in this catalog, please be sure to read the instruction manual prior to use.

Mitsubishi Electric Corporation Nagoya Works is a factory certified for ISO14001 (standards for environmental management systems) and ISO9001 (standards for quality assurance management systems)



MITSUBISHI ELECTRIC CORPORATION

HEAD OFFICE: TOKYO BLDG., 2-7-3, MARUNOUCHI, CHIYODA-KU, TOKYO 100-8310, JAPAN