

Programmable Controller

CC-Link IE TSN Remote I/O Module User's Manual (CC-Link IE Field Network Communication Mode)

-NZ2GN2S1-16D
-NZ2GN2S1-32D
-NZ2GN2B1-16D
-NZ2GN2B1-32D
-NZ2GNCF1-32D
-NZ2GNCE3-32D
-NZ2GN12A4-16D
-NZ2GN12A4-16DE
-NZ2GN2S1-16T
-NZ2GN2S1-32T
-NZ2GN2B1-16T
-NZ2GN2B1-32T
-NZ2GNCF1-32T
-NZ2GN12A2-16T
-NZ2GN2S1-16TE
-NZ2GN2S1-32TE
-NZ2GN2B1-16TE
-NZ2GN2B1-32TE
-NZ2GN12A2-16TE
-NZ2GN2S1-32DT
-NZ2GN2B1-32DT
-NZ2GNCE3-32DT
-NZ2GN12A42-16DT
-NZ2GN2S1-32DTE
-NZ2GN2B1-32DTE
-NZ2GN12A42-16DTE

SAFETY PRECAUTIONS

(Read these precautions before using this product.)

Before using this product, please read this manual and the relevant manuals carefully and pay full attention to safety to handle the product correctly.

The precautions given in this manual are concerned with this product only. For the safety precautions of the programmable controller system, refer to the user's manual for the CPU module used.

In this manual, the safety precautions are classified into two levels: "⚠️ WARNING" and "⚠️ CAUTION".

WARNING

Indicates that incorrect handling may cause hazardous conditions, resulting in death or severe injury.

CAUTION

Indicates that incorrect handling may cause hazardous conditions, resulting in minor or moderate injury or property damage.

Under some circumstances, failure to observe the precautions given under "⚠️ CAUTION" may lead to serious consequences.

Observe the precautions of both levels because they are important for personal and system safety.

Make sure that the end users read this manual and then keep the manual in a safe place for future reference.

[Design Precautions]

WARNING

- In the case of a communication failure in the network, data of the master station are held. Check Data link status (each station) (SW00B0 to SW00B7) and configure an interlock circuit in the program to ensure that the entire system will operate safely.
 - When the module is disconnected due to a communication failure in the network or the CPU module is in the STOP state, outputs are held or turned off according to the output HOLD/CLEAR setting. Configure an interlock circuit in the program to ensure that the entire system will always operate safely even in such a case. If not, an accident may occur due to an incorrect output or malfunction.
 - Outputs may remain on or off due to a failure of the module. Configure an external circuit for monitoring output signals that could cause a serious accident.
 - Do not use any "use prohibited" signals as a remote input or output signal. These signals are reserved for system use. Do not write any data to the "use prohibited" areas in the remote register. If these operations are performed, an accident may occur due to an incorrect output or malfunction.
-

[Design Precautions]

CAUTION

- Do not install the control lines or communication cables together with the main circuit lines or power cables. Keep a distance of 100mm or more between them. Failure to do so may result in malfunction due to noise.
 - During control of an inductive load such as a lamp, heater, or solenoid valve, a large current (approximately ten times greater than normal) may flow when the output is turned from off to on. Therefore, use a module that has a sufficient current rating.
-

[Security Precautions]

WARNING

- To maintain the security (confidentiality, integrity, and availability) of the programmable controller and the system against unauthorized access, denial-of-service (DoS) attacks, computer viruses, and other cyberattacks from external devices via the network, take appropriate measures such as firewalls, virtual private networks (VPNs), and antivirus solutions.
-

[Installation Precautions]

WARNING

- Shut off the external power supply (all phases) used in the system before mounting or removing a module. Failure to do so may result in electric shock or cause the module to fail or malfunction.
-

[Installation Precautions]

CAUTION

- Use the module in an environment that meets the general specifications in this manual. Failure to do so may result in electric shock, fire, malfunction, or damage to or deterioration of the product.
 - Do not directly touch any conductive parts and electronic components of the module. Doing so can cause malfunction or failure of the module.
 - Securely connect the cable connectors. Poor contact may cause malfunction.
 - After the first use of the product, do not connect/remove the connector more than 50 times (IEC 61131-2/JIS B 3502 compliant). Exceeding the limit may cause malfunction.
 - Securely fix the waterproof/dustproof module with the mounting screws. If not, the module will be greatly affected by vibration, causing failure of the module.
-

[Wiring Precautions]

WARNING

- Shut off the external power supply (all phases) used in the system before wiring. Failure to do so may result in electric shock or cause the module to fail or malfunction.
-

[Wiring Precautions]

CAUTION

- Individually ground the FG terminal of the programmable controller with a ground resistance of 100 ohms or less. Failure to do so may result in electric shock or malfunction.
 - Tighten any unused terminal screws within the specified torque range. Undertightening can cause a short circuit due to contact with a solderless terminal.
 - Use applicable solderless terminals and tighten them within the specified torque range. If any spade solderless terminal is used, it may be disconnected when a terminal block screw comes loose, resulting in failure.
 - Before wiring to the module or to loads, check the rated voltage and terminal layout of the module, and connect the cables correctly. Connecting a power supply with a different voltage rating or incorrect wiring may cause a fire or failure.
 - Tighten the terminal block screws within the specified torque range. Undertightening can cause short circuit, fire, or malfunction. Overtightening can damage the screw and/or module, resulting in drop, short circuit, fire, or malfunction.
 - Prevent foreign matter such as dust or wire chips from entering the module. Such foreign matter can cause a fire, failure, or malfunction.
 - Place the cables in a duct or clamp them. If not, dangling cables may swing or inadvertently be pulled, resulting in malfunction or damage to modules or cables.
In addition, the weight of the cables may put stress on modules in an environment of strong vibrations and shocks.
 - Do not install the control lines or communication cables together with the main circuit lines or power cables. Keep a distance of 100mm or more between them. Failure to do so may result in malfunction due to noise.
 - When disconnecting the cable from the module, do not pull the cable by the cable part. For the cable with connector, hold the connector part of the cable. For the cable connected to the terminal block, loosen the terminal screw. Pulling the cable connected to the module may result in malfunction or damage to the module or cable.
 - When an overcurrent caused by an error of an external device or a failure of the programmable controller flows for a long time, it may cause smoke and fire. To prevent this, configure an external safety circuit, such as a fuse.
 - Mitsubishi programmable controllers must be installed in control panels. Wiring and replacement of a module must be performed by qualified maintenance personnel with knowledge of protection against electric shock. For wiring methods, refer to "INSTALLATION AND WIRING" in this manual.
 - When attaching waterproof caps to the waterproof/dustproof module, tighten the caps within the specified torque range. Undertightening can cause short circuit, fire, or malfunction. Overtightening can damage the cap, resulting in short circuit or malfunction.
 - For the waterproof/dustproof module, periodically check the connectors (such as I/O connectors, communication connectors, and power supply connectors) and the screws of indicator cover. Retighten any connectors and screws that are loose.
 - The waterproof/dustproof module is compliant with IP67 only when all necessary waterproof connectors and caps have been installed and the indicator cover has been properly tightened with screws.
 - For the waterproof/dustproof module, do not remove the gasket from the indicator cover to keep waterproofing of the cover.
 - Attach waterproof caps to the waterproof/dustproof module to prevent dirt and dust from entering the module, or prevent the static electricity from causing the module to fail or malfunction.
-

[Wiring Precautions]

CAUTION

- For waterproof cables used for the waterproof/dustproof module, use UL listed cables in the categories "CYJV" and "PVVA", with the suitable voltage, current, and temperature rating (the operating temperature range of the cables: 75°C or higher).
 - Do not replace or wire the waterproof/dustproof module immediately after powering off the system because the connector parts of the module can get really hot depending on the load conditions.
-

[Startup and Maintenance Precautions]

WARNING

- Do not touch any terminal while power is on. Doing so will cause electric shock or malfunction.
 - Shut off the external power supply (all phases) used in the system before cleaning the module, retightening the terminal block screws or connector screws, or operating the IP address/station number setting switches. Failure to do so may cause the module to fail or malfunction.
-

[Startup and Maintenance Precautions]

CAUTION

- Do not disassemble or modify the module. Doing so may cause failure, malfunction, injury, or a fire.
 - Do not drop or apply strong shock to the module. Doing so may damage the module.
 - Use any radio communication device such as a cellular phone or PHS (Personal Handy-phone System) more than 25cm away from wiring as well as away in all directions from the programmable controller. Failure to do so may cause malfunction.
 - Shut off the external power supply (all phases) used in the system before mounting or removing a module. Failure to do so may cause the module to fail or malfunction.
 - After the first use of the product, do not mount/remove the terminal block to/from the module more than 50 times (IEC 61131-2/JIS B 3502 compliant). Exceeding the limit may cause malfunction.
 - After the first use of the product, do not connect/remove the connector more than 50 times (IEC 61131-2/JIS B 3502 compliant). Exceeding the limit may cause malfunction.
 - Before handling the module or connection cables, touch a conducting object such as a grounded metal to discharge the static electricity from the human body. Failure to do so may cause the module to fail or malfunction.
 - Startup and maintenance of a control panel must be performed by qualified maintenance personnel with knowledge of protection against electric shock. Lock the control panel so that only qualified maintenance personnel can operate it.
-

[Disposal Precautions]

CAUTION

- When disposing of this product, treat it as industrial waste.
-

CONDITIONS OF USE FOR THE PRODUCT

- (1) MELSEC programmable controller ("the PRODUCT") shall be used in conditions;
- i) where any problem, fault or failure occurring in the PRODUCT, if any, shall not lead to any major or serious accident; and
 - ii) where the backup and fail-safe function are systematically or automatically provided outside of the PRODUCT for the case of any problem, fault or failure occurring in the PRODUCT.
- (2) The PRODUCT has been designed and manufactured for the purpose of being used in general industries. MITSUBISHI ELECTRIC SHALL HAVE NO RESPONSIBILITY OR LIABILITY (INCLUDING, BUT NOT LIMITED TO ANY AND ALL RESPONSIBILITY OR LIABILITY BASED ON CONTRACT, WARRANTY, TORT, PRODUCT LIABILITY) FOR ANY INJURY OR DEATH TO PERSONS OR LOSS OR DAMAGE TO PROPERTY CAUSED BY THE PRODUCT THAT ARE OPERATED OR USED IN APPLICATION NOT INTENDED OR EXCLUDED BY INSTRUCTIONS, PRECAUTIONS, OR WARNING CONTAINED IN MITSUBISHI ELECTRIC USER'S, INSTRUCTION AND/OR SAFETY MANUALS, TECHNICAL BULLETINS AND GUIDELINES FOR the PRODUCT.
- ("Prohibited Application")
- Prohibited Applications include, but not limited to, the use of the PRODUCT in;
- Nuclear Power Plants and any other power plants operated by Power companies, and/or any other cases in which the public could be affected if any problem or fault occurs in the PRODUCT.
 - Railway companies or Public service purposes, and/or any other cases in which establishment of a special quality assurance system is required by the Purchaser or End User.
 - Aircraft or Aerospace, Medical applications, Train equipment, transport equipment such as Elevator and Escalator, Incineration and Fuel devices, Vehicles, Manned transportation, Equipment for Recreation and Amusement, and Safety devices, handling of Nuclear or Hazardous Materials or Chemicals, Mining and Drilling, and/or other applications where there is a significant risk of injury to the public or property.
- Notwithstanding the above restrictions, Mitsubishi Electric may in its sole discretion, authorize use of the PRODUCT in one or more of the Prohibited Applications, provided that the usage of the PRODUCT is limited only for the specific applications agreed to by Mitsubishi Electric and provided further that no special quality assurance or fail-safe, redundant or other safety features which exceed the general specifications of the PRODUCTS are required. For details, please contact the Mitsubishi Electric representative in your region.
- (3) Mitsubishi Electric shall have no responsibility or liability for any problems involving programmable controller trouble and system trouble caused by DoS attacks, unauthorized access, computer viruses, and other cyberattacks.

INTRODUCTION

Thank you for purchasing the CC-Link IE TSN remote I/O module and the waterproof/dustproof remote I/O module (hereafter referred to as I/O module).

This manual describes the procedures, system configuration, parameter settings, functions, and troubleshooting required to use the following modules in CC-Link IE Field Network communication mode.

Before using this product, please read this manual and the relevant manuals carefully and develop familiarity with the functions and performance of the I/O module to handle the product correctly.

When applying the program examples introduced in this manual to an actual system, ensure the applicability and confirm that it will not cause system control problems.

CC-Link IE Field Network communication mode

When using the I/O module as an intelligent device station on CC-Link IE Field Network, select CC-Link IE Field Network communication mode.

To operate the I/O module in CC-Link IE Field Network communication mode, set the function setting switch 1 to ON. (☞ Page 117 Function setting switch setting)

Restriction

I/O modules with the firmware version of 02 or later are compatible with CC-Link IE Field Network communication mode.

For other system information, refer to the following.

☞ Page 108 SYSTEM CONFIGURATION

Relevant products

NZ2GN2S1-16D, NZ2GN2S1-32D, NZ2GN2B1-16D, NZ2GN2B1-32D, NZ2GNCF1-32D, NZ2GNCE3-32D, NZ2GN12A4-16D, NZ2GN12A4-16DE, NZ2GN2S1-16T, NZ2GN2S1-32T, NZ2GN2B1-16T, NZ2GN2B1-32T, NZ2GNCF1-32T, NZ2GN2S1-16TE, NZ2GN2S1-32TE, NZ2GN2B1-16TE, NZ2GN2B1-32TE, NZ2GN12A2-16T, NZ2GN12A2-16TE, NZ2GN2S1-32DT, NZ2GN2B1-32DT, NZ2GNCE3-32DT, NZ2GN2S1-32DTE, NZ2GN2B1-32DTE, NZ2GN12A42-16DT, NZ2GN12A42-16DTE

Point

Unless otherwise specified, this manual describes the program examples in which the remote I/O signals and remote registers are assigned for an I/O module as follows.

- Remote input signals: RX0 to RX1F
- Remote output signals: RY0 to RY1F
- Remote register: RWr0 to RWr4F
- Remote register: RWw0 to RWw4F

For the assignment of remote I/O signals and remote registers, refer to the following.

☞ Page 173 Program Example

CONTENTS

SAFETY PRECAUTIONS	1
CONDITIONS OF USE FOR THE PRODUCT	5
INTRODUCTION	6
RELEVANT MANUALS	10
TERMS	11
GENERIC TERMS AND ABBREVIATIONS	12
CHAPTER 1 PRODUCT LINEUP	13
1.1 List of Products	13
Input modules	13
Output modules	14
I/O combined module	15
CHAPTER 2 PART NAMES	16
CHAPTER 3 SPECIFICATIONS	19
3.1 General Specifications	19
3.2 Performance Specifications	21
Input module	21
Output module	46
I/O combined module	79
3.3 Function List	105
CHAPTER 4 PROCEDURES BEFORE OPERATION	106
CHAPTER 5 SYSTEM CONFIGURATION	108
5.1 Applicable Systems	108
CHAPTER 6 INSTALLATION AND WIRING	110
6.1 Before Using the I/O Modules	110
Input modules	110
Output modules	111
I/O combined module	113
6.2 Setting Switch	114
Indicator cover of the I/O module (waterproof module)	114
Setting the IP address/station number setting switches	115
Function setting switch setting	117
6.3 Installation Environment and Installation Position	119
Installation environment	119
Installation position	120
Installation direction	121
6.4 Installation	122
Mounting the I/O modules (except for waterproof module) on a DIN rail	122
Fixing the I/O module (waterproof module)	123
6.5 Wiring of Terminal Block for Module Power Supply and FG	124
6.6 Wiring of Connector for Module Power Supply and FG	127
6.7 Wiring the I/O Module (Waterproof Module) to the Power Supply	130
6.8 Wiring of Ethernet Cable	131

6.9	Wiring of I/O Module and External Device	134
	Wiring of spring clamp terminal block	134
	Wiring of screw terminal block	138
	Wiring of 40-pin connector	140
	Wiring of sensor connector (e-CON)	145
	Wiring of waterproof connectors	146
6.10	List of Recommended Cables/Connectors for the I/O Module (Waterproof Module)	147
6.11	Attaching Waterproof Caps	149
CHAPTER 7 PARAMETER SETTING		150
7.1	Network Configuration Setting	150
CHAPTER 8 FUNCTIONS		152
8.1	Input Response Time Setting Function	152
8.2	Output HOLD/CLEAR Setting Function	153
8.3	CC-Link IE Field Network Synchronous Communication Function	154
	Synchronous X/Y control mode	155
	Synchronization cycle timing control mode	157
	Setting method	161
8.4	Fast Link-Up Function	163
	How to use the fast link-up function	165
8.5	Output ON/OFF Information Hold Function	167
8.6	Protection Function	168
8.7	Module Power Supply Voltage Drop Detection Function	169
8.8	External Power Supply Monitoring Function	169
8.9	Firmware Update Function	170
CHAPTER 9 PROGRAMMING		171
9.1	Precautions for Programming	171
9.2	Program Example	173
9.3	Program Example for Using the Fast Link-Up Function	178
CHAPTER 10 MAINTENANCE AND INSPECTION		183
CHAPTER 11 TROUBLESHOOTING		185
11.1	CC-Link IE TSN/CC-Link IE Field Diagnostics	185
11.2	Checking the LEDs	188
11.3	Unit Test	192
11.4	Troubleshooting by Symptom	193
11.5	Examples of Troubles with the I/O Module	195
	Troubleshooting for input circuit	195
	Troubleshooting for output circuit	198
11.6	Method for Checking Error Codes	205
11.7	Error Code List	211
APPENDICES		213
Appendix 1	Remote I/O Signal	213
	List of remote I/O signals	213
	Details of remote input signals	219
	Details of remote output signals	219

Appendix 2 Remote Register	220
List of remote registers	220
Details of remote registers	226
Appendix 3 Remote Buffer Memory	236
List of remote buffer memory areas	236
Details of remote buffer memory	238
Appendix 4 CC-Link IE Field Network Processing Time	242
Appendix 5 EMC and Low Voltage Directives	243
Measures to comply with the EMC Directive	243
Requirements to compliance with the Low Voltage Directive	249
Appendix 6 How to Check Production Information and Firmware Version	250
Appendix 7 External Dimensions	252
INDEX	256
<hr/>	
REVISIONS	258
WARRANTY	259
TRADEMARKS	260

RELEVANT MANUALS

Manual name [manual number]	Description	Available form
CC-Link IE TSN Remote I/O Module User's Manual (CC-Link IE Field Network Communication Mode) [SH-082240ENG] (this manual)	Part names, specifications, procedures before operation, system configuration, installation, wiring, parameter settings, functions, programming, troubleshooting, I/O signals, and remote buffer memory of the I/O module to be used in CC-Link IE Field Network communication mode	Print book e-Manual PDF
CC-Link IE TSN Remote I/O Module User's Manual (CC-Link IE TSN Communication Mode) [SH-082135ENG]	Part names, specifications, procedures before operation, system configuration, installation, wiring, parameter settings, functions, programming, troubleshooting, and I/O signals of the I/O module to be used in CC-Link IE TSN communication mode	Print book e-Manual PDF
MELSEC iQ-R Ethernet/CC-Link IE User's Manual (Startup) [SH-081256ENG]	Specifications, procedures before operation, system configuration, wiring, and communication examples of Ethernet, CC-Link IE Controller Network, and CC-Link IE Field Network	Print book e-Manual PDF
MELSEC iQ-R CC-Link IE Field Network User's Manual (Application) [SH-081259ENG]	Functions, parameter settings, programming, troubleshooting, I/O signals, and buffer memory of CC-Link IE Field Network	Print book e-Manual PDF
MELSEC iQ-R Inter-Module Synchronization Function Reference Manual [SH-081401ENG]	Inter-module synchronization function, which controls multiple modules synchronously	e-Manual PDF
MELSEC-L CC-Link IE Field Network Master/Local Module User's Manual [SH-080972ENG]	Specifications, procedures before operation, system configuration, installation, wiring, settings, functions, programming, and troubleshooting of CC-Link IE Field Network and LJ71GF11-T2	Print book e-Manual PDF
MELSEC-Q CC-Link IE Field Network Master/Local Module User's Manual [SH-080917ENG]	Specifications, procedures before operation, system configuration, installation, wiring, settings, functions, programming, and troubleshooting of CC-Link IE Field Network and QJ71GF11-T2	Print book e-Manual PDF
MELSEC iQ-R Simple Motion Module User's Manual (Network) [IB-0300307ENG]	Functions, parameter settings, troubleshooting, and buffer memory of CC-Link IE Field Network	Print book e-Manual PDF
MELSEC iQ-R Simple Motion Module User's Manual (Application) [IB-0300247ENG]	Functions, parameter settings, I/O signals, buffer memory, programming, and troubleshooting of the Simple Motion module	Print book e-Manual PDF
MELSEC iQ-R Simple Motion Module User's Manual (Advanced Synchronous Control) [IB-0300249ENG]	Functions and programming related to synchronous control of the Simple Motion module	Print book e-Manual PDF
MELSEC-Q QD77GF Simple Motion Module User's Manual (Positioning Control) [IB-0300202]	Specifications of the QD77GF and information on how to establish a system, maintenance and inspection, and troubleshooting. Functions, programming and buffer memory for the positioning control of the QD77GF	Print book PDF
MELSEC-Q QD77GF Simple Motion Module User's Manual (Network) [IB-0300203]	Functions, programming, and troubleshooting for CC-Link IE Field Network of the QD77GF	Print book PDF
GX Works3 Operating Manual [SH-081215ENG]	System configuration, parameter settings, and online operations of GX Works3	e-Manual PDF
GX Works2 Version 1 Operating Manual (Common) [SH-080779ENG]	Functions common to Simple and Structured projects, such as the system configuration, parameter settings, and online function operation methods of GX Works2	Print book e-Manual PDF



e-Manual refers to the Mitsubishi Electric FA electronic book manuals that can be browsed using a dedicated tool.

e-Manual has the following features:

- Required information can be cross-searched in multiple manuals.
- Other manuals can be accessed from the links in the manual.
- The hardware specifications of each part can be found from the product figures.
- Pages that users often browse can be bookmarked.
- Sample programs can be copied to an engineering tool.

TERMS

Unless otherwise specified, this manual uses the following terms.

Term	Description
Cyclic transmission	A function by which data are periodically exchanged among stations on the same network using link devices
Data link	Communications performed by cyclic transmission and transient transmission
Engineering tool	A tool used for setting up programmable controllers, programming, debugging, and maintenance
Intelligent device station	A station that exchanges I/O signals (bit data) and I/O data (word data) with the master station by cyclic transmission. This station can perform transient transmission as well. This station responds to a transient transmission request from another station and also issues a transient transmission request to another station.
Link device	A device (RX, RY, RWr, RWw, SB, or SW) in a module or a board on CC-Link IE Field Network
Local station	A station that performs cyclic transmission and transient transmission with the master station and other local stations.
Master station	A station that controls the entire network. This station can perform cyclic transmission and transient transmission with all stations. Only one master station can be used in a network.
Remote device station	A station that exchanges I/O signals (bit data) and I/O data (word data) with the master station by cyclic transmission. This station responds to a transient transmission request from another station.
Reserved station	A station reserved for future use. This station is not actually connected, but counted as a connected station.
Slave station	A station other than a master station: a local station, a remote I/O station, a remote device station, and an intelligent device station
Transient transmission	A function of communication with another station, which is used when requested by a dedicated instruction or an engineering tool

GENERIC TERMS AND ABBREVIATIONS

Unless otherwise specified, this manual uses the following generic terms and abbreviations.

Generic term/abbreviation	Description
A/D converter module	An abbreviation for the CC-Link IE TSN analog-digital converter module
CC-Link IE TSN remote module	A generic term for an A/D converter module, a D/A converter module, an I/O module
D/A converter module	An abbreviation for the CC-Link IE TSN digital-analog converter module
I/O combined module	A generic term for modules that can input and output a digital signal
I/O combined module (except for waterproof module)	A generic term for modules except for waterproof/dustproof modules that can input and output a digital signal
I/O combined module (waterproof module)	A generic term for waterproof/dustproof modules that can input and output a digital signal
I/O module	An abbreviation for the CC-Link IE TSN remote I/O module
I/O module (except for waterproof module)	An abbreviation for the CC-Link IE TSN remote I/O module that is not waterproof or dustproof
I/O module (waterproof module)	An abbreviation for the CC-Link IE TSN waterproof/dustproof remote I/O module
Input module	A generic term for modules that can input a digital signal
Input module (except for waterproof module)	A generic term for modules except for waterproof/dustproof modules that can input a digital signal
Input module (waterproof module)	A generic term for waterproof/dustproof modules that can input a digital signal
Output module	A generic term for modules that can output a digital signal
Output module (except for waterproof module)	A generic term for modules except for waterproof/dustproof modules that can output a digital signal
Output module (waterproof module)	A generic term for waterproof/dustproof modules that can output a digital signal
REMFR	The abbreviation for ZP.REMFR.
REMRD	An abbreviation for JP.REMRD
REMT0	The abbreviation for ZP.REMT0.
REMTOD	An abbreviation for JP.REMTOD
RWr	An abbreviation for the remote register of link device. RWr refers to word data input from a slave station to the master station (For some areas in a local station, data are input in the opposite direction.)
RWw	An abbreviation for the remote register of link device. RWw refers to word data output from the master station to a slave station (For some areas in a local station, data are output in the opposite direction.)
RX	An abbreviation for remote input of link device. Bit data input from a slave station to the master station (For some areas in a local station, data are input in the opposite direction.)
RY	An abbreviation for remote output of link device. Bit data output from the master station to a slave station (For some areas in a local station, data are output in the opposite direction.)

1 PRODUCT LINEUP

1.1 List of Products

Input modules

Module name		Input specifications	Module power supply current	Weight	Model	Reference
DC input module	Positive common/ negative common shared type	Spring clamp terminal block 24VDC, 16 points	110mA	0.15kg	NZ2GN2S1-16D	☞ Page 21 NZ2GN2S1-16D DC input module
		Spring clamp terminal block 24VDC, 32 points	110mA	0.20kg	NZ2GN2S1-32D	☞ Page 24 NZ2GN2S1-32D DC input module
		Screw terminal block 24VDC, 16 points	110mA	0.21kg	NZ2GN2B1-16D	☞ Page 27 NZ2GN2B1-16D DC input module
		Screw terminal block 24VDC, 32 points	110mA	0.31kg	NZ2GN2B1-32D	☞ Page 30 NZ2GN2B1-32D DC input module
		40-pin connector 24VDC, 32 points	110mA	0.20kg	NZ2GNCF1-32D	☞ Page 33 NZ2GNCF1-32D DC input module
	Positive common type	Sensor connector (e-CON) 24VDC, 32 points	110mA	0.25kg	NZ2GNCE3-32D	☞ Page 36 NZ2GNCE3-32D DC input module
		Waterproof connector 24VDC, 16 points	250mA	0.41kg	NZ2GN12A4-16D	☞ Page 40 NZ2GN12A4-16D DC input module
	Negative common type	Waterproof connector 24VDC, 16 points	250mA	0.41kg	NZ2GN12A4-16DE	☞ Page 43 NZ2GN12A4-16DE DC input module

Output modules

Module name		Output specifications	Module power supply current	Weight	Model	Reference
Transistor output module	Sink type	Spring clamp terminal block 12/24VDC, 0.5A/point, 16 points	110mA	0.15kg	NZ2GN2S1-16T	☞ Page 46 NZ2GN2S1-16T transistor output module
		Spring clamp terminal block 12/24VDC, 0.5A/point, 32 points	120mA	0.18kg	NZ2GN2S1-32T	☞ Page 49 NZ2GN2S1-32T transistor output module
		Screw terminal block 12/24VDC, 0.5A/point, 16 points	110mA	0.21kg	NZ2GN2B1-16T	☞ Page 52 NZ2GN2B1-16T transistor output module
		Screw terminal block 12/24VDC, 0.5A/point, 32 points	120mA	0.29kg	NZ2GN2B1-32T	☞ Page 55 NZ2GN2B1-32T transistor output module
		40-pin connector 12/24VDC, 0.1A/point, 32 points	120mA	0.16kg	NZ2GNCF1-32T	☞ Page 58 NZ2GNCF1-32T transistor output module
		Waterproof connector 12/24VDC, 4A/point (Y0 to Y3), 2A/point (Y4 to YF), 16 points	110mA	0.42kg	NZ2GN12A2-16T	☞ Page 61 NZ2GN12A2-16T transistor output module
	Source type	Spring clamp terminal block 12/24VDC, 0.5A/point, 16 points	110mA	0.15kg	NZ2GN2S1-16TE	☞ Page 64 NZ2GN2S1-16TE transistor output module
		Spring clamp terminal block 12/24VDC, 0.5A/point, 32 points	120mA	0.18kg	NZ2GN2S1-32TE	☞ Page 67 NZ2GN2S1-32TE transistor output module
		Screw terminal block 12/24VDC, 0.5A/point, 16 points	110mA	0.21kg	NZ2GN2B1-16TE	☞ Page 70 NZ2GN2B1-16TE transistor output module
		Screw terminal block 12/24VDC, 0.5A/point, 32 points	120mA	0.29kg	NZ2GN2B1-32TE	☞ Page 73 NZ2GN2B1-32TE transistor output module
		Waterproof connector 12/24VDC, 4A/point (Y0 to Y3), 2A/point (Y4 to YF), 16 points	110mA	0.42kg	NZ2GN12A2-16TE	☞ Page 76 NZ2GN12A2-16TE transistor output module

I/O combined module

Module name	Input specifications	Output specifications	Module power supply current	Weight	Model	Reference	
DC input/transistor output module	<ul style="list-style-type: none"> Input part: Positive common type Output part: Sink type 	Spring clamp terminal block 24VDC, 16 points	Spring clamp terminal block 24VDC, 0.5A/point, 16 points	110mA	0.20kg	NZ2GN2S1-32DT	Page 79 NZ2GN2S1-32DT DC input/transistor output module
		Screw terminal block 24VDC, 16 points	Screw terminal block 24VDC, 0.5A/point, 16 points	110mA	0.31kg	NZ2GN2B1-32DT	Page 83 NZ2GN2B1-32DT DC input/transistor output module
		Sensor connector (e-CON) 24VDC, 16 points	Sensor connector (e-CON) 24VDC, 0.5A/point, 16 points	110mA	0.25kg	NZ2GNCE3-32DT	Page 87 NZ2GNCE3-32DT DC input/transistor output module
		Waterproof connector 24VDC, 8 points	Waterproof connector 12/24VDC, 4A/point (Y8 to YB), 2A/point (YC to YF), 8 points	160mA	0.42kg	NZ2GN12A42-16DT	Page 91 NZ2GN12A42-16DT DC input/transistor output module
	<ul style="list-style-type: none"> Input part: Negative common type Output part: Source type 	Spring clamp terminal block 24VDC, 16 points	Spring clamp terminal block 24VDC, 0.5A/point, 16 points	110mA	0.20kg	NZ2GN2S1-32DTE	Page 95 NZ2GN2S1-32DTE DC input/transistor output module
		Screw terminal block 24VDC, 16 points	Screw terminal block 24VDC, 0.5A/point, 16 points	110mA	0.31kg	NZ2GN2B1-32DTE	Page 98 NZ2GN2B1-32DTE DC input/transistor output module
		Waterproof connector 24VDC, 8 points	Waterproof connector 12/24VDC, 4A/point (Y8 to YB), 2A/point (YC to YF), 8 points	160mA	0.42kg	NZ2GN12A42-16DTE	Page 101 NZ2GN12A42-16DTE DC input/transistor output module

2 PART NAMES

This section describes part names of the I/O module.

- Spring clamp terminal block type

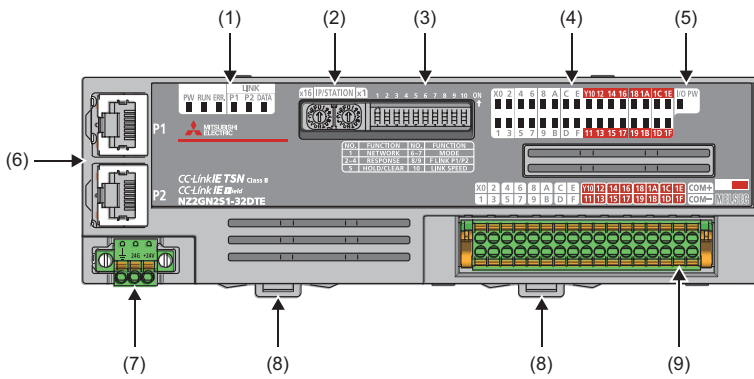

- Screw terminal block type

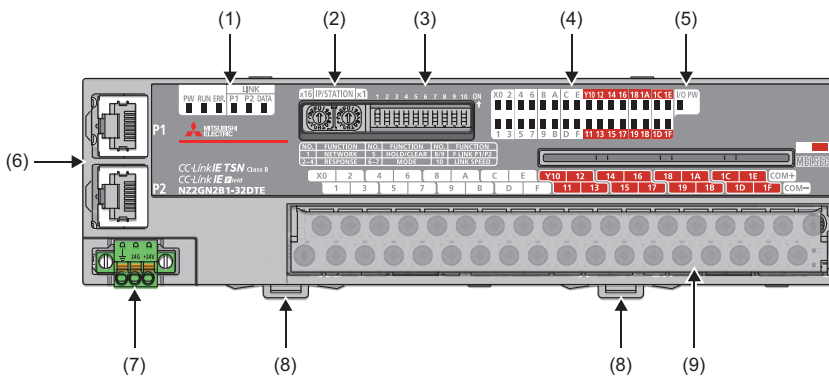

- 40-pin connector type

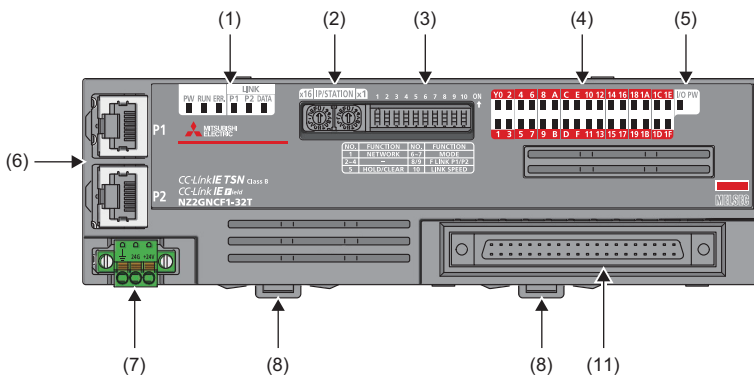

- Sensor connector (e-CON) type

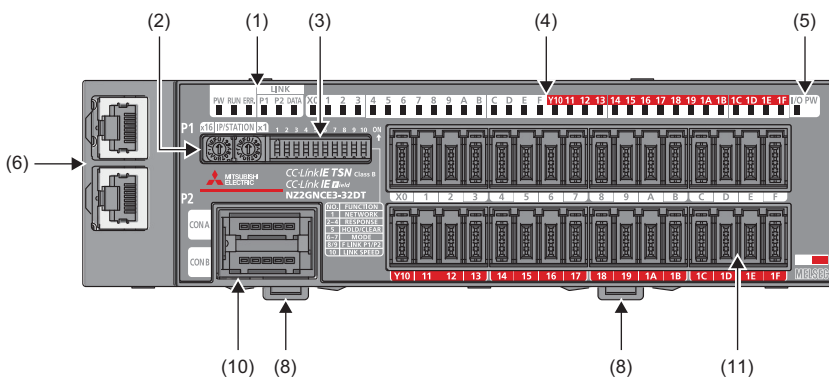

• Waterproof/dustproof connector type

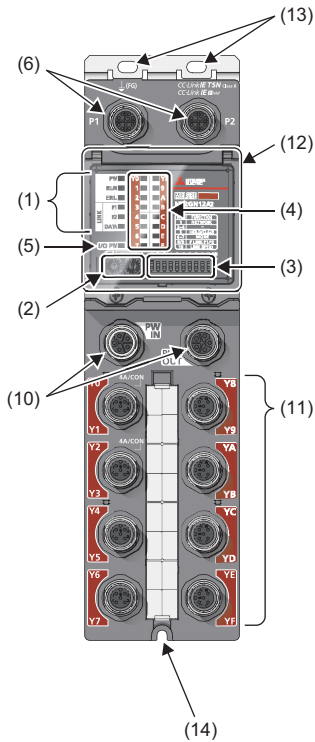

No.	Name	Application
(1)	PW LED	Indicates the power supply status of the I/O module. On: Power supply ON Off: Power supply OFF
	RUN LED	Indicates the operating status of the I/O module. On: Operating normally. Flashing: Operating in unit test mode Off: A major error has occurred.
	ERR. LED	Indicates the error status of the I/O module. On: A moderate error or major error has occurred. Flashing: A minor error has occurred. Off: Operating normally.
	P1 LINK LED	Indicates the link status for P1. On: Link-up Off: Linkdown in progress
	P2 LINK LED	Indicates the link status for P2. On: Link-up Off: Linkdown in progress
	DATA LINK LED	Indicates the data link status of the I/O module. On: Cyclic transmission being performed Flashing: Cyclic transmission stopped Off: Disconnected
(2)	IP address/station number setting switch	Sets the station number. ☞ Page 115 Setting the IP address/station number setting switches
(3)	Function setting switch	Sets functions of the I/O module. ☞ Page 117 Function setting switch setting
(4)	■16-point module X0 LED to XF LED ■32-point module X0 LED to X1F LED	Indicates the ON/OFF status of the inputs.*1 On: Input ON Off: Input OFF
	■16-point module Y0 LED to YF LED ■32-point module Y0 LED to Y1F LED	Indicates the ON/OFF status of the outputs.*2 On: Output ON Off: Output OFF
(5)	I/O PW LED	Indicates the status of the power supply from the external power supply. On: External power supply ON Off: External power supply OFF

No.	Name	Application
(6)	P1	A port for the connection to CC-Link IE Field Network (RJ45 connector/M12 waterproof connector) Connect an Ethernet cable. (☞ Page 131 Wiring of Ethernet Cable) There are no restrictions on the connection order of the cables for P1 and P2.
	P2	Same as P1
(7)	Terminal block for module power supply and FG	A terminal block to connect the module power supply (24VDC) and FG.
(8)	DIN rail hook	A hook to mount an I/O module on a DIN rail
(9)	I/O terminal block	A terminal block for I/O power supply and I/O signals
(10)	Connector for module power supply and FG	A connector for the module power supply (24VDC) and FG
(11)	Connector for I/O	A connector for the I/O power supply and I/O signals
(12)	Indicator cover	A protective cover for LEDs and switches
(13)	FG metal fitting/mounting metal fitting	A metal fitting for FG connection or mounting the module
(14)	Module mounting hole	A hole for a module mounting screw

*1 The status of actual input signals that are externally input is indicated on the LEDs regardless of the status of the remote input signal.

*2 Output commands from the I/O module are indicated on the LEDs regardless of the status of the external power supply.

I/O module status and LED status

The following table lists the correspondence between the I/O module status and the LED status.

I/O module status		LED status			
		PW LED	RUN LED	DATA LINK LED	ERR. LED
Disconnected		On	On	Off	*1
Data link in operation		On	On	On	*1
Reserved station setting in progress		On	On	Flashing	*1
Data link stop		On	On	Flashing	*1
Communication error		On	On	Flashing	*1
Unit test	In progress	On	Flashing	Off	Off
	Normal completion	On	On	Off	Off
	Abnormal completion	On	On	Off	On
Error	Major error	On	Off	*1	On
	Moderate error	On	On	*1	On
	Minor error	On	On	*1	Flashing

*1 Either of On, Flashing, or Off.

3 SPECIFICATIONS

This chapter describes the specifications of the I/O module.

3.1 General Specifications

I/O module (except for waterproof module)

Item	Specifications					
Operating ambient temperature	0 to 55°C					
Storage ambient temperature	-25 to 75°C					
Operating ambient humidity	5 to 95%RH, non-condensing					
Storage ambient humidity						
Vibration resistance	Compliant with JIS B 3502 and IEC 61131-2	—	Frequency	Constant acceleration	Half amplitude	Number of sweeps
		Under intermittent vibration	5 to 8.4Hz	—	3.5mm	10 times each in X, Y, and Z directions
			8.4 to 150Hz	9.8m/s ²	—	
		Under continuous vibration	5 to 8.4Hz	—	1.75mm	—
8.4 to 150Hz	4.9m/s ²		—			
Shock resistance	Compliant with JIS B 3502 and IEC 61131-2 (147m/s ² , 3 times each in X, Y, and Z directions)					
Operating atmosphere	No corrosive gases, flammable gases, less conductive dust					
Operating altitude ^{*1}	0 to 2000m					
Installation location	Inside a control panel ^{*2}					
Overvoltage category ^{*3}	II or less					
Pollution degree ^{*4}	2 or less					
Equipment class	Class I					

*1 Do not use or store the I/O module (except for the waterproof module) under pressure higher than the atmospheric pressure of altitude 0m. Doing so may cause malfunction. When using the I/O module under pressure, please consult your local Mitsubishi representative.

*2 If the environment satisfies the operating ambient temperature, operating ambient humidity and other conditions, the module can be used even outside the control panel.

*3 This indicates the section of the power supply to which the equipment is assumed to be connected between the public electrical power distribution network and the machinery within premises.

Category II applies to equipment for which electrical power is supplied from fixed facilities. The surge voltage withstand level for the equipment with the rated voltage of 300V or less is 2500V.

*4 This index indicates the degree to which conductive material is generated in terms of the environment in which the equipment is used. Pollution degree 2 is when only non-conductive pollution occurs. A temporary conductivity caused by condensing must be expected occasionally.

Point

For compliance with the EMC Directive, refer to the following:

 Page 243 EMC and Low Voltage Directives

I/O module (waterproof module)

Item	Specifications					
Operating ambient temperature	0 to 55°C					
Storage ambient temperature	-25 to 75°C					
Operating ambient humidity	Compliant with IP67 ^{*1}					
Storage ambient humidity	5 to 95%RH, non-condensing					
Vibration resistance	Compliant with JIS B 3502 and IEC 61131-2	—	Frequency	Constant acceleration	Half amplitude	Number of sweeps
		Under intermittent vibration	5 to 8.4Hz	—	3.5mm	10 times each in X, Y, and Z directions
			8.4 to 150Hz	9.8m/s ²	—	
		Under continuous vibration	5 to 8.4Hz	—	1.75mm	—
8.4 to 150Hz	4.9m/s ²		—			
Shock resistance	Compliant with JIS B 3502 and IEC 61131-2 (147m/s ² , 3 times each in X, Y, and Z directions)					
Operating atmosphere	No corrosive gases, flammable gases, less conductive dust					
Operating altitude ^{*2}	0 to 2000m					
Installation location	Inside a control panel ^{*3}					
Overvoltage category ^{*4}	II or less					
Pollution degree ^{*5}	2 or less					
Equipment class	Class I					

*1 Only when all necessary waterproof connectors and caps have been installed and the indicator cover for the IP address/station number setting switches and the function setting switches has been properly tightened with screws, the module is compliant with IP67. For the tightening torque range of the cover screws for the switches, refer to the following.

 Page 114 Indicator cover of the I/O module (waterproof module), Page 149 Attaching Waterproof Caps

*2 Do not use or store the I/O module (waterproof module) under pressure higher than the atmospheric pressure of altitude 0m. Doing so may cause malfunction.

*3 If the environment satisfies the operating ambient temperature, operating ambient humidity and other conditions, the module can be used even outside the control panel.

*4 This indicates the section of the power supply to which the equipment is assumed to be connected between the public electrical power distribution network and the machinery within premises. Category II applies to equipment for which electrical power is supplied from fixed facilities. The surge voltage withstand level for the equipment with the rated voltage of 300V or less is 2500V.

*5 This index indicates the degree to which conductive material is generated in terms of the environment in which the equipment is used. Pollution degree 2 is when only non-conductive pollution occurs. A temporary conductivity caused by condensing must be expected occasionally.

Point

For compliance with the EMC Directive, refer to the following:

 Page 243 EMC and Low Voltage Directives

3.2 Performance Specifications

Input module

NZ2GN2S1-16D DC input module

Item	NZ2GN2S1-16D	
Station type	Remote device station	
Network topology	Line topology, star topology, mixture of star topology and line topology, ring topology	
Number of input points	16 points	
Rated input voltage	24VDC (ripple rate: 5% or less) (Allowable voltage range: 20.4 to 28.8VDC)	
Rated input current	6.6mA TYP. (for 24VDC)	
Maximum number of simultaneous input points	100%	
ON voltage/ON current	11VDC or more/4mA or more	
OFF voltage/OFF current	5VDC or less/1.5mA or less	
Input resistance	3.3kΩ	
Input response time	OFF → ON	0ms ^{*1} /0.2ms/1ms/1.5ms/5ms/10ms/20ms/70ms
	ON → OFF	(Factory default: 1ms)
Withstand voltage	510VAC for 1 minute between all DC external terminals and ground	
Insulation resistance	10MΩ or higher between all DC external terminals and ground (500VDC insulation resistance tester)	
Noise immunity ^{*2}	Noise voltage 500Vp-p, noise width 1μs, noise frequency 25 to 60Hz (DC type noise simulator condition)	
Protection degree	IP2X	
Wiring method for common	16 points/common (Common terminal: terminal number 17, 18) (1-wire, spring clamp terminal block type) Positive common/negative common shared type	
External interface	Communication part	RJ45 connector
	Module power supply part	Terminal block for module power supply and FG (2-piece spring clamp terminal block)
	I/O part	18-point two-piece spring clamp terminal block
Applicable wire size	For power supply	Stranded wire: 0.3 to 1.5mm ² (22 to 16 AWG), terminal slot size: 2.4mm × 1.5mm ^{*3}
	For I/O	Stranded wire: 0.3 to 1.5mm ² (22 to 16 AWG)
Applicable solderless terminal ^{*4}	Terminal block for module power supply and FG	☞ Page 124 Applicable solderless terminal
	Terminal block for input	☞ Page 134 Applicable solderless terminal
Multicast filter	Available	
Cyclic transmission	RX/RY points	16 points
	RWr/RWw points	4 points ^{*5}
Module power supply	Voltage	24VDC (ripple rate: 5% or less) (Allowable voltage range: 20.4 to 28.8VDC)
	Current	110mA or less (24VDC, all points ON)
Weight	0.15kg	

*1 If the input response time is set to "0ms", the actual input response time is 80μs at OFF → ON, and 160μs at ON → OFF.

*2 It is the noise immunity of when the input response time setting value is other than "0ms". Note that the module is easily affected by noise if "0ms" is set.

*3 Use bar solderless terminals for wiring.

*4 Only one wire can be inserted into a wire insertion opening. Multiple wires cannot be connected to a terminal. Connecting two or more wires may cause a poor contact.

*5 This value indicates the number of points set by default when the module is dragged and dropped to the network map in the CC IE Field Configuration window. According to the function used, set an appropriate number of points. (☞ Page 220 Input module (16-point module))

External wiring

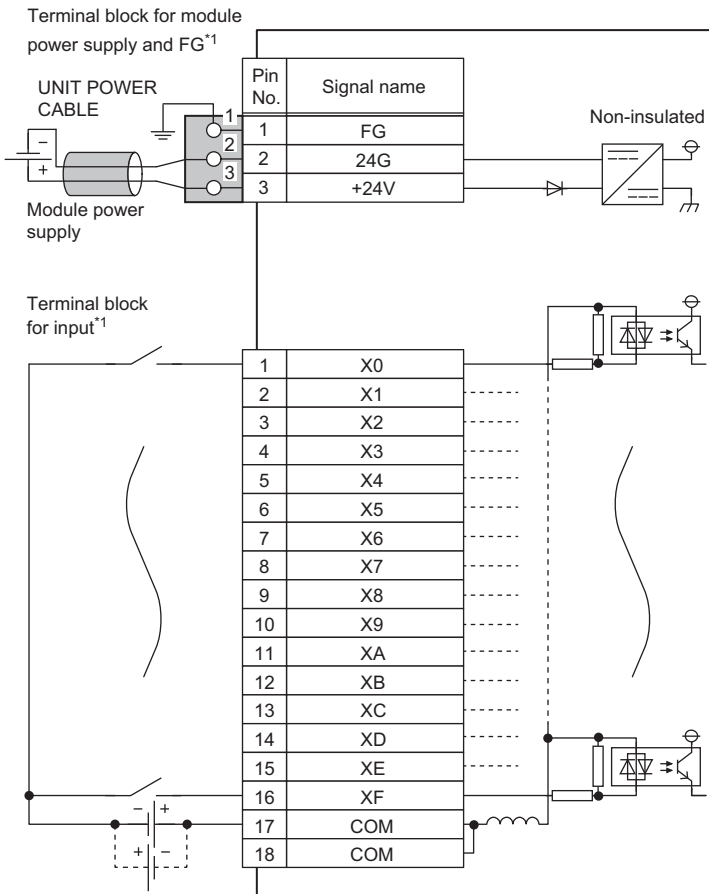

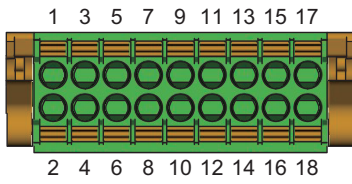

*1 Only one wire can be inserted into a wire insertion opening. Multiple wires cannot be connected to a terminal. Connecting two or more wires may cause a poor contact.

■ Terminal block for input



Terminal number	Signal name
1	X0
2	X1
3	X2
4	X3
5	X4
6	X5
7	X6
8	X7
9	X8
10	X9
11	XA
12	XB
13	XC
14	XD
15	XE
16	XF
17	COM
18	COM

NZ2GN2S1-32D DC input module

Item		NZ2GN2S1-32D
Station type		Intelligent device station
Network topology		Line topology, star topology, mixture of star topology and line topology, ring topology
Number of input points		32 points
Rated input voltage		24VDC (ripple rate: 5% or less) (Allowable voltage range: 20.4 to 28.8VDC)
Rated input current		6.0mA TYP. (for 24VDC)
Maximum number of simultaneous input points		100%
ON voltage/ON current		11VDC or more/4mA or more
OFF voltage/OFF current		5VDC or less/1.5mA or less
Input resistance		3.3k Ω
Input response time	OFF \rightarrow ON	0ms ^{*1} /0.2ms/1ms/1.5ms/5ms/10ms/20ms/70ms
	ON \rightarrow OFF	(Factory default: 1ms)
Withstand voltage		510VAC for 1 minute between all DC external terminals and ground
Insulation resistance		10M Ω or higher between all DC external terminals and ground (500VDC insulation resistance tester)
Noise immunity ^{*2}		Noise voltage 500Vp-p, noise width 1 μ s, noise frequency 25 to 60Hz (DC type noise simulator condition)
Protection degree		IP2X
Wiring method for common		32 points/common (Common terminal: terminal number 33, 34) (1-wire, spring clamp terminal block type) Positive common/negative common shared type
External interface	Communication part	RJ45 connector
	Module power supply part	Terminal block for module power supply and FG (2-piece spring clamp terminal block)
	I/O part	2-piece spring clamp terminal block
Applicable wire size	For power supply	Stranded wire: 0.3 to 1.5mm ² (22 to 16 AWG), terminal slot size: 2.4mm \times 1.5mm ^{*3}
	For I/O	Stranded wire: 0.3 to 1.5mm ² (22 to 16 AWG)
Applicable solderless terminal ^{*4}	Terminal block for module power supply and FG	 Page 124 Applicable solderless terminal
	Terminal block for input	 Page 134 Applicable solderless terminal
Cyclic transmission	RX/RX points	32 points
	RWw/RWw points	4 points ^{*5}
Module power supply	Voltage	24VDC (ripple rate: 5% or less) (Allowable voltage range: 20.4 to 28.8VDC)
	Current	110mA or less (24VDC, all points ON)
Weight		0.20kg

*1 If the input response time is set to "0ms", the actual input response time is 80 μ s at OFF \rightarrow ON, and 160 μ s at ON \rightarrow OFF.

*2 It is the noise immunity of when the input response time setting value is other than "0ms". Note that the module is easily affected by noise if "0ms" is set.

*3 Use bar solderless terminals for wiring.

*4 Only one wire can be inserted into a wire insertion opening. Multiple wires cannot be connected to a terminal. Connecting two or more wires may cause a poor contact.

*5 This value indicates the number of points set by default when the module is dragged and dropped to the network map in the CC IE Field Configuration window. According to the function used, set an appropriate number of points. ( Page 221 Input module (32-point module))

External wiring

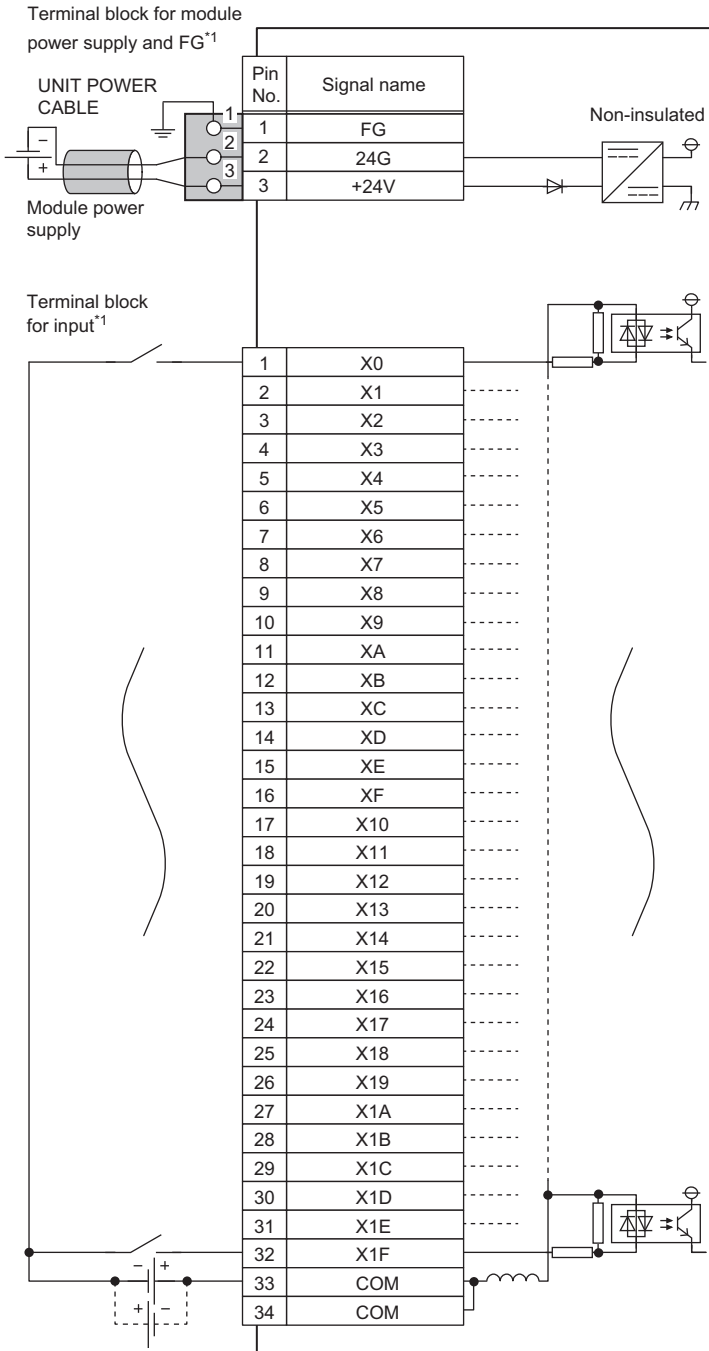

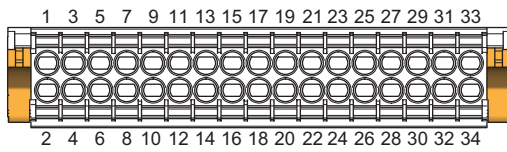

*1 Only one wire can be inserted into a wire insertion opening. Multiple wires cannot be connected to a terminal. Connecting two or more wires may cause a poor contact.

■ Terminal block for input



Terminal number	Signal name	Terminal number	Signal name
1	X0	17	X10
2	X1	18	X11
3	X2	19	X12
4	X3	20	X13
5	X4	21	X14
6	X5	22	X15
7	X6	23	X16
8	X7	24	X17
9	X8	25	X18
10	X9	26	X19
11	XA	27	X1A
12	XB	28	X1B
13	XC	29	X1C
14	XD	30	X1D
15	XE	31	X1E
16	XF	32	X1F
—		33	COM
		34	COM

NZ2GN2B1-16D DC input module

Item		NZ2GN2B1-16D
Station type		Remote device station
Network topology		Line topology, star topology, mixture of star topology and line topology, ring topology
Number of input points		16 points
Rated input voltage		24VDC (ripple rate: 5% or less) (Allowable voltage range: 20.4 to 28.8VDC)
Rated input current		6.6mA TYP. (for 24VDC)
Maximum number of simultaneous input points		100%
ON voltage/ON current		11VDC or more/4mA or more
OFF voltage/OFF current		5VDC or less/1.5mA or less
Input resistance		3.3k Ω
Input response time	OFF \rightarrow ON	0ms ^{*1} /0.2ms/1ms/1.5ms/5ms/10ms/20ms/70ms
	ON \rightarrow OFF	(Factory default: 1ms)
Withstand voltage		510VAC for 1 minute between all DC external terminals and ground
Insulation resistance		10M Ω or higher between all DC external terminals and ground (500VDC insulation resistance tester)
Noise immunity ^{*2}		Noise voltage 500Vp-p, noise width 1 μ s, noise frequency 25 to 60Hz (DC type noise simulator condition)
Protection degree		IP2X
Wiring method for common		16 points/common (Common terminal: terminal number 17, 18) (1-wire, screw terminal block type) Positive common/negative common shared type
External interface	Communication part	RJ45 connector
	Module power supply part	Terminal block for module power supply and FG (2-piece spring clamp terminal block)
	I/O part	18-point two-piece terminal block Tightening torque range for terminal screw (M3 \times 5.2 screw): 0.43 to 0.57N-m Tightening torque range for terminal block mounting screw (M3.5 screw): 0.68 to 0.92N-m
Applicable wire size	For power supply	Stranded wire: 0.3 to 1.5mm ² (22 to 16 AWG), terminal slot size: 2.4mm \times 1.5mm ^{*3}
	For I/O	Stranded wire: 0.3 to 2.0mm ² (22 to 14 AWG)
Applicable solderless terminal	Terminal block for module power supply and FG ^{*4}	 Page 124 Applicable solderless terminal
	Terminal block for input	 Page 138 Applicable solderless terminal
Multicast filter		Available
Cyclic transmission	RX/Ry points	16 points
	RWr/RWw points	4 points ^{*5}
Module power supply	Voltage	24VDC (ripple rate: 5% or less) (Allowable voltage range: 20.4 to 28.8VDC)
	Current	110mA or less (24VDC, all points ON)
Weight		0.21kg

*1 If the input response time is set to "0ms", the actual input response time is 80 μ s at OFF \rightarrow ON, and 160 μ s at ON \rightarrow OFF.

*2 It is the noise immunity of when the input response time setting value is other than "0ms". Note that the module is easily affected by noise if "0ms" is set.

*3 Use bar solderless terminals for wiring.

*4 Only one wire can be inserted into a wire insertion opening for the terminal block for module power supply and FG. Multiple wires cannot be connected to a terminal. Connecting two or more wires may cause a poor contact.

*5 This value indicates the number of points set by default when the module is dragged and dropped to the network map in the CC IE Field Configuration window. According to the function used, set an appropriate number of points. ( Page 220 Input module (16-point module))

External wiring

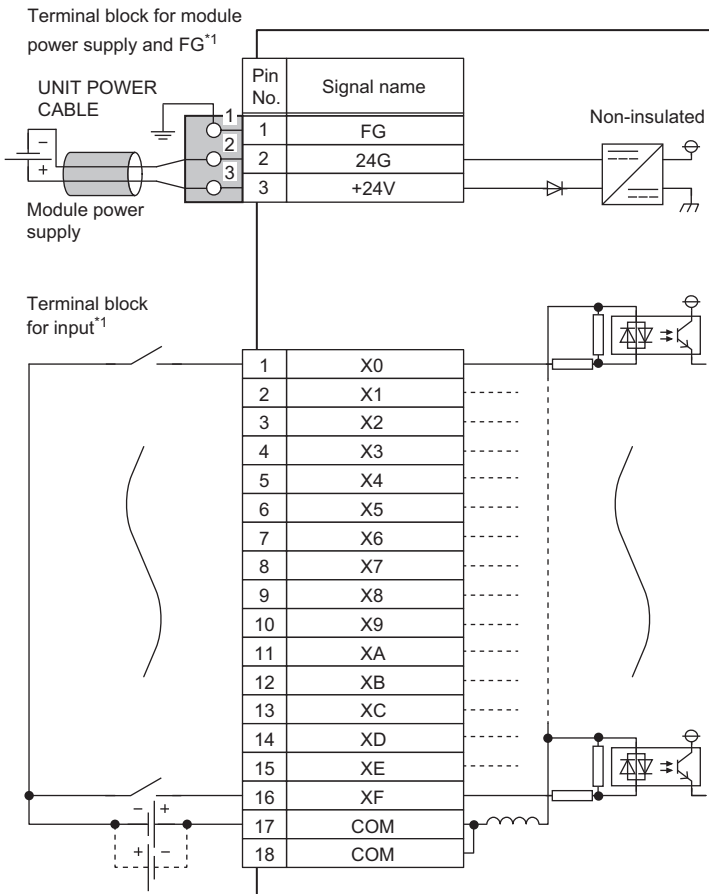

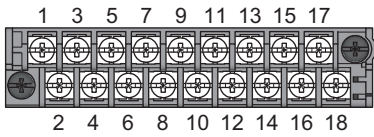

*1 Only one wire can be inserted into a wire insertion opening for the terminal block for module power supply and FG. Multiple wires cannot be connected to a terminal. Connecting two or more wires may cause a poor contact.

Terminal block for input



Terminal number	Signal name
1	X0
2	X1
3	X2
4	X3
5	X4
6	X5
7	X6
8	X7
9	X8
10	X9
11	XA
12	XB
13	XC
14	XD
15	XE
16	XF
17	COM
18	COM

NZ2GN2B1-32D DC input module

Item		NZ2GN2B1-32D
Station type		Intelligent device station
Network topology		Line topology, star topology, mixture of star topology and line topology, ring topology
Number of input points		32 points
Rated input voltage		24VDC (ripple rate: 5% or less) (Allowable voltage range: 20.4 to 28.8VDC)
Rated input current		6.0mA TYP. (for 24VDC)
Maximum number of simultaneous input points		100%
ON voltage/ON current		11VDC or more/4mA or more
OFF voltage/OFF current		5VDC or less/1.5mA or less
Input resistance		3.3k Ω
Input response time	OFF \rightarrow ON	0ms ^{*1} /0.2ms/1ms/1.5ms/5ms/10ms/20ms/70ms
	ON \rightarrow OFF	(Factory default: 1ms)
Withstand voltage		510VAC for 1 minute between all DC external terminals and ground
Insulation resistance		10M Ω or higher between all DC external terminals and ground (500VDC insulation resistance tester)
Noise immunity ^{*2}		Noise voltage 500Vp-p, noise width 1 μ s, noise frequency 25 to 60Hz (DC type noise simulator condition)
Protection degree		IP2X
Wiring method for common		32 points/common (Common terminal: terminal number 33, 34) (1-wire, screw terminal block type) Positive common/negative common shared type
External interface	Communication part	RJ45 connector
	Module power supply part	Terminal block for module power supply and FG (2-piece spring clamp terminal block)
	I/O part	34-point two-piece terminal block Tightening torque range for terminal screw (M3 \times 5.2 screw): 0.43 to 0.57N-m Tightening torque range for terminal block mounting screw (M3.5 screw): 0.68 to 0.92N-m
Applicable wire size	For power supply	Stranded wire: 0.3 to 1.5mm ² (22 to 16 AWG), terminal slot size: 2.4mm \times 1.5mm ^{*3}
	For I/O	Stranded wire: 0.3 to 2.0mm ² (22 to 14 AWG)
Applicable solderless terminal	Terminal block for module power supply and FG ^{*4}	 Page 124 Applicable solderless terminal
	Terminal block for input	 Page 138 Applicable solderless terminal
Cyclic transmission	RX/RY points	32 points
	RWr/RWw points	4 points ^{*5}
Module power supply	Voltage	24VDC (ripple rate: 5% or less) (Allowable voltage range: 20.4 to 28.8VDC)
	Current	110mA or less (24VDC, all points ON)
Weight		0.31kg

*1 If the input response time is set to "0ms", the actual input response time is 80 μ s at OFF \rightarrow ON, and 160 μ s at ON \rightarrow OFF.

*2 It is the noise immunity of when the input response time setting value is other than "0ms". Note that the module is easily affected by noise if "0ms" is set.

*3 Use bar solderless terminals for wiring.

*4 Only one wire can be inserted into a wire insertion opening for the terminal block for module power supply and FG. Multiple wires cannot be connected to a terminal. Connecting two or more wires may cause a poor contact.

*5 This value indicates the number of points set by default when the module is dragged and dropped to the network map in the CC IE Field Configuration window. According to the function used, set an appropriate number of points. ( Page 221 Input module (32-point module))

External wiring

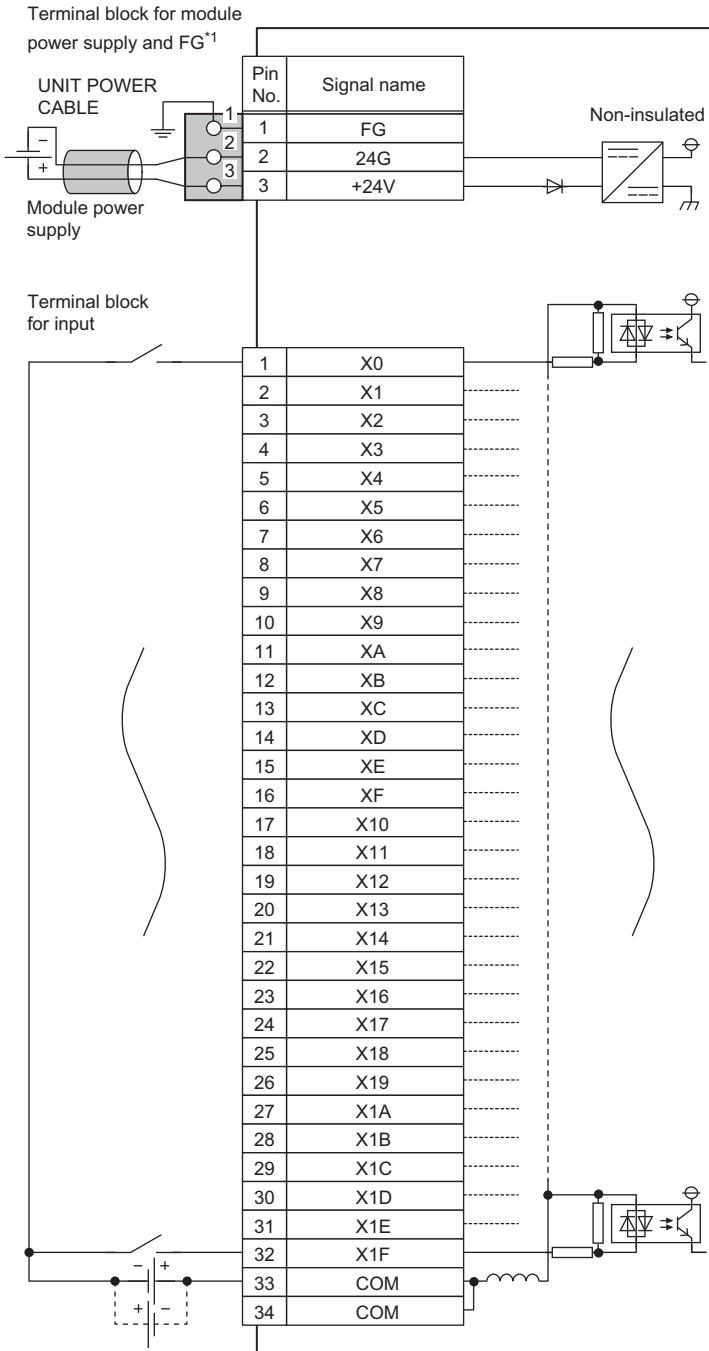

*1 Only one wire can be inserted into a wire insertion opening for the terminal block for module power supply and FG. Multiple wires cannot be connected to a terminal. Connecting two or more wires may cause a poor contact.

Terminal block for input

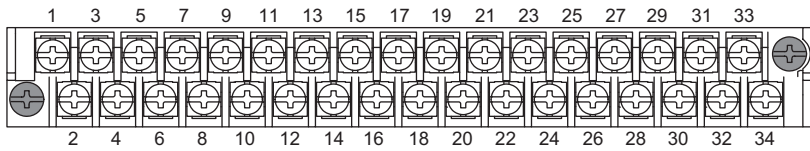

Terminal number	Signal name	Terminal number	Signal name
1	X0	17	X10
2	X1	18	X11
3	X2	19	X12
4	X3	20	X13
5	X4	21	X14
6	X5	22	X15
7	X6	23	X16
8	X7	24	X17
9	X8	25	X18
10	X9	26	X19
11	XA	27	X1A
12	XB	28	X1B
13	XC	29	X1C
14	XD	30	X1D
15	XE	31	X1E
16	XF	32	X1F
—		33	COM
		34	COM

NZ2GNCF1-32D DC input module

Item		NZ2GNCF1-32D
Station type		Intelligent device station
Network topology		Line topology, star topology, mixture of star topology and line topology, ring topology
Number of input points		32 points
Rated input voltage		24VDC (ripple rate: 5% or less) (Allowable voltage range: 20.4 to 28.8VDC)
Rated input current		6.6mA TYP. (for 24VDC)
Maximum number of simultaneous input points		100% ^{*6}
ON voltage/ON current		11VDC or more/4mA or more
OFF voltage/OFF current		5VDC or less/1.5mA or less
Input resistance		3.3k Ω
Input response time	OFF \rightarrow ON	0ms ^{*1} /0.2ms/1ms/1.5ms/5ms/10ms/20ms/70ms
	ON \rightarrow OFF	(Factory default: 1ms)
Withstand voltage		510VAC for 1 minute between all DC external terminals and ground
Insulation resistance		10M Ω or higher between all DC external terminals and ground (500VDC insulation resistance tester)
Noise immunity ^{*2}		Noise voltage 500Vp-p, noise width 1 μ s, noise frequency 25 to 60Hz (DC type noise simulator condition)
Protection degree		IP2X
Wiring method for common		32 points/common (Common terminal: pin number B1, B2) (1-wire, 40-pin connector type) Positive common/negative common shared type
External interface	Communication part	RJ45 connector
	Module power supply part	Terminal block for module power supply and FG (2-piece spring clamp terminal block)
	I/O part	40-pin connector
Applicable wire size	For power supply	Stranded wire: 0.3 to 1.5mm ² (22 to 16 AWG), terminal slot size: 2.4mm \times 1.5mm ^{*3}
	For I/O	40-pin connector The size depends on the connector plug used (sold separately). (☞ Page 140 Wiring of 40-pin connector)
Applicable solderless terminal ^{*4}	Terminal block for module power supply and FG	☞ Page 124 Applicable solderless terminal
Cyclic transmission	RX/RV points	32 points
	RW/RVw points	4 points ^{*5}
Module power supply	Voltage	24VDC (ripple rate: 5% or less) (Allowable voltage range: 20.4 to 28.8VDC)
	Current	110mA or less (24VDC, all points ON)
Weight		0.20kg

*1 If the input response time is set to "0ms", the actual input response time is 80 μ s at OFF \rightarrow ON, and 160 μ s at ON \rightarrow OFF.

*2 It is the noise immunity of when the input response time setting value is other than "0ms". Note that the module is easily affected by noise if "0ms" is set.

*3 Use bar solderless terminals for wiring.

*4 Only one wire can be inserted into a wire insertion opening for the terminal block for module power supply and FG. Multiple wires cannot be connected to a terminal. Connecting two or more wires may cause a poor contact.

*5 This value indicates the number of points set by default when the module is dragged and dropped to the network map in the CC IE Field Configuration window. According to the function used, set an appropriate number of points. (☞ Page 221 Input module (32-point module))

*6 For the points for downward installation, horizontal installation (upside down), and upward installation, refer to the derating chart below.

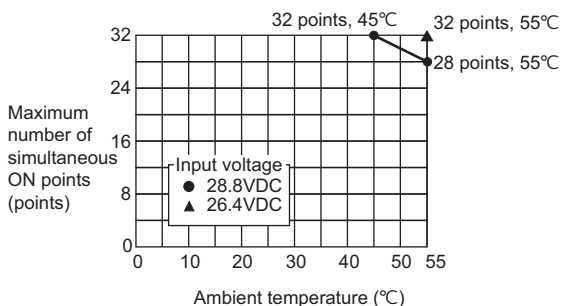

External wiring

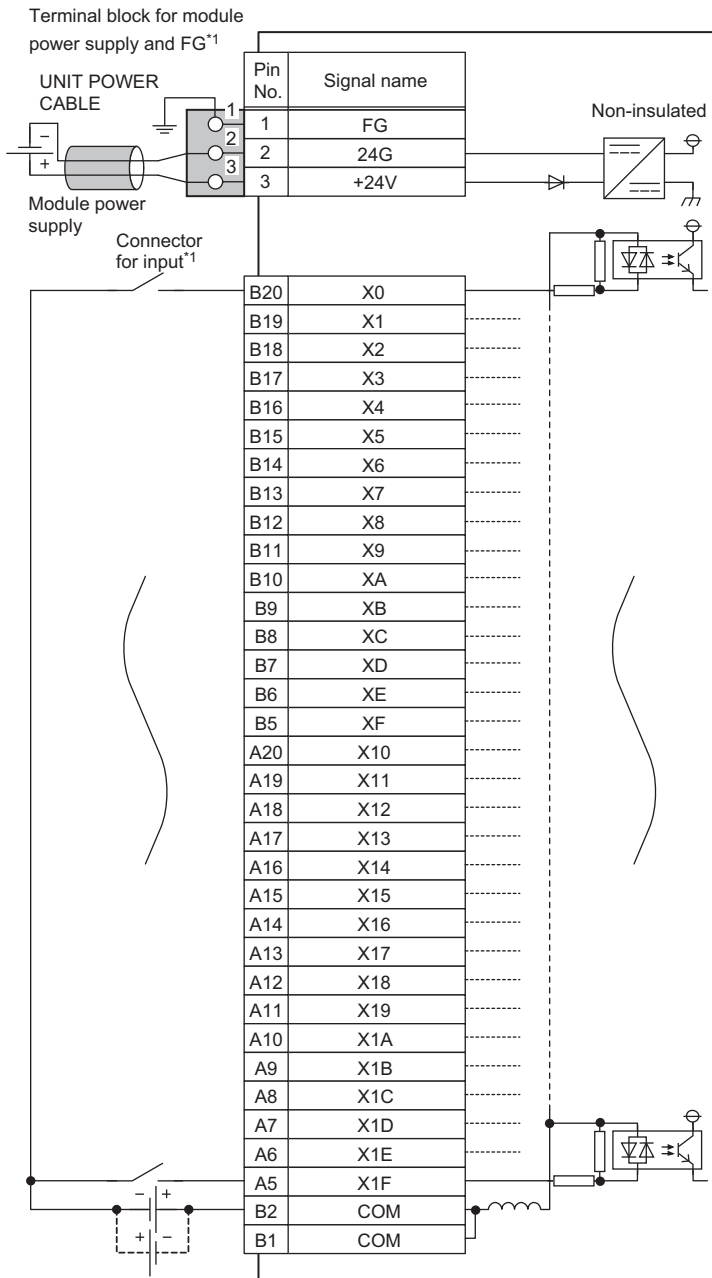

*1 Only one wire can be inserted into a wire insertion opening for the following: terminal block for module power supply and FG, connector for input. Multiple wires cannot be connected to a terminal. Connecting two or more wires may cause a poor contact.

■ Connector for input

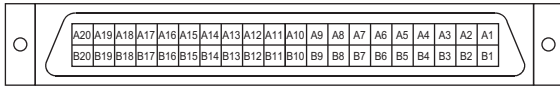

Terminal number	Signal name	Terminal number	Signal name
B20	X0	A20	X10
B19	X1	A19	X11
B18	X2	A18	X12
B17	X3	A17	X13
B16	X4	A16	X14
B15	X5	A15	X15
B14	X6	A14	X16
B13	X7	A13	X17
B12	X8	A12	X18
B11	X9	A11	X19
B10	XA	A10	X1A
B9	XB	A9	X1B
B8	XC	A8	X1C
B7	XD	A7	X1D
B6	XE	A6	X1E
B5	XF	A5	X1F
B4	Empty	A4	Empty
B3	Empty	A3	Empty
B2	COM	A2	Empty
B1	COM	A1	Empty

NZ2GNCE3-32D DC input module

Item		NZ2GNCE3-32D
Station type		Intelligent device station
Network topology		Line topology, star topology, mixture of star topology and line topology, ring topology
Number of input points		32 points
Rated input voltage		24VDC (ripple rate: 5% or less) (Allowable voltage range: 20.4 to 28.8VDC)
Rated input current		6.6mA TYP. (for 24VDC)
Maximum number of simultaneous input points		100%
ON voltage/ON current		11VDC or more/4mA or more
OFF voltage/OFF current		5VDC or less/1.5mA or less
Input resistance		3.3k Ω
Input response time	OFF \rightarrow ON	0ms ^{*1} /0.2ms/1ms/1.5ms/5ms/10ms/20ms/70ms
	ON \rightarrow OFF	(Factory default: 1ms)
Withstand voltage		510VAC for 1 minute between all DC external terminals and ground
Insulation resistance		10M Ω or higher between all DC external terminals and ground (500VDC insulation resistance tester)
Noise immunity ^{*2}		Noise voltage 500Vp-p, noise width 1 μ s, noise frequency 25 to 60Hz (DC type noise simulator condition)
Protection degree		IP2X
Wiring method for common		32 points/common (3-wire, sensor connector (e-CON)) Positive common type
External interface	Communication part	RJ45 connector
	Module power supply part	One-touch connector for power supply and FG (5 pins, crimping type)
	I/O part	Sensor connector (e-CON) (4 pins, crimping type)
Applicable wire size	For power supply	0.66 to 0.98mm ² (18 AWG) [Finishing outer diameter: ϕ 2.2 to 3.0mm (A6CON-PW5P), ϕ 2.0 to 2.3mm (A6CON-PW5P-SOD)] Strand diameter: 0.16mm or longer Insulating coating material: PVC (heat resistant vinyl)
	For I/O	Sensor connector (e-CON) The size depends on the connector plug used (sold separately). (☞ Page 145 Wiring of sensor connector (e-CON))
Cyclic transmission	RX/RY points	32 points
	RWr/RWw points	4 points ^{*3}
Module power supply	Voltage	24VDC (ripple rate: 5% or less) (Allowable voltage range: 20.4 to 28.8VDC)
	Current	110mA or less (24VDC, all points ON)
Weight		0.25kg

*1 If the input response time is set to "0ms", the actual input response time is 80 μ s at OFF \rightarrow ON, and 160 μ s at ON \rightarrow OFF.

*2 It is the noise immunity of when the input response time setting value is other than "0ms". Note that the module is easily affected by noise if "0ms" is set.

*3 This value indicates the number of points set by default when the module is dragged and dropped to the network map in the CC IE Field Configuration window. According to the function used, set an appropriate number of points. (☞ Page 221 Input module (32-point module))

External wiring

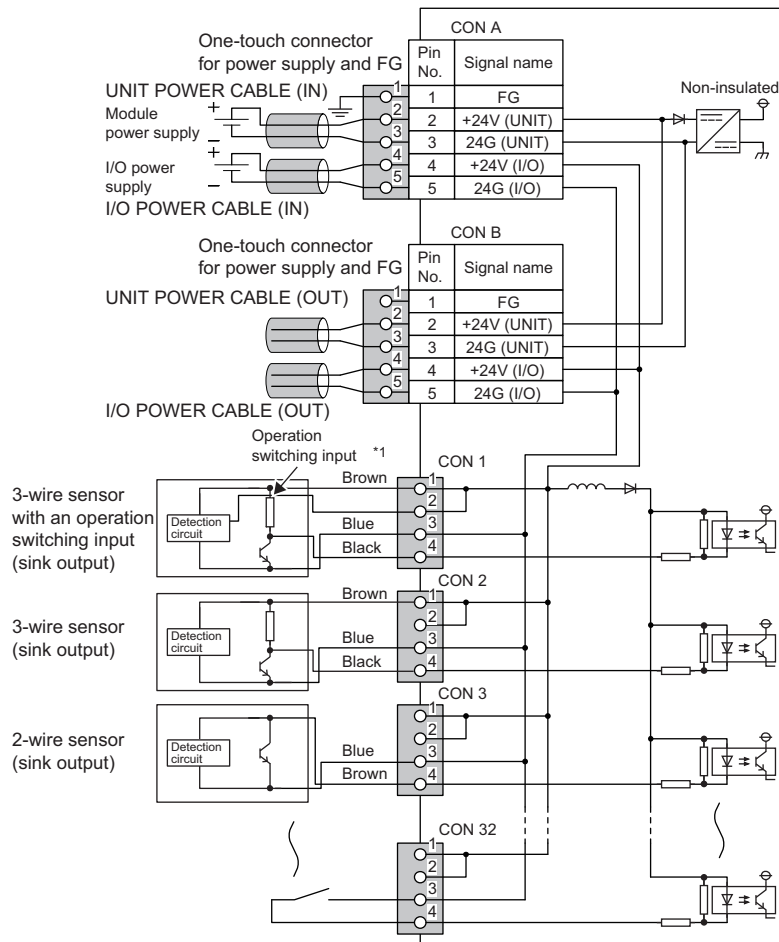

- When an online connector is connected

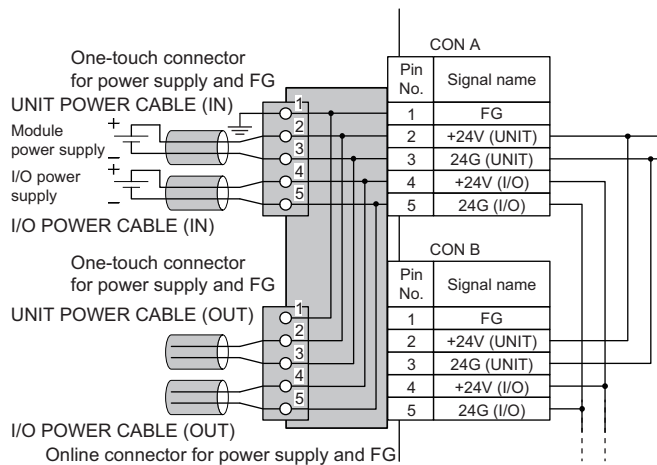

- *1 The colors of leads correspond to IEC 60947-5-2.

■ Connector for module power supply and FG

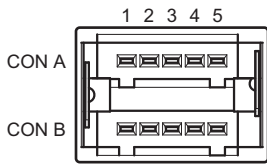

Terminal number ^{*1}	Signal name	
CON A	1	FG
CON B	2	+24V (UNIT)
	3	24G (UNIT)
	4	+24V (I/O)
	5	24G (I/O)

*1 A non-wired connector must be connected to the empty slot of the connector for module power supply and FG.

■ Connector for input

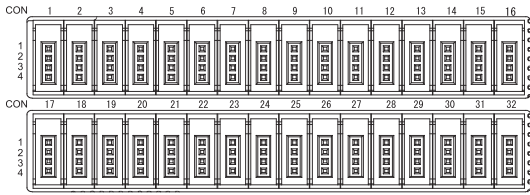

Terminal number	Signal name	Terminal number	Signal name	Terminal number	Signal name	Terminal number	Signal name				
CON1 (X0)	1	+24V	CON9 (X8)	1	+24V	CON17 (X10)	1	+24V	CON25 (X18)	1	+24V
	2	+V		2	+V		2	+V		2	+V
	3	24G		3	24G		3	24G		3	24G
	4	X0		4	X8		4	X10		4	X18
CON2 (X1)	1	+24V	CON10 (X9)	1	+24V	CON18 (X11)	1	+24V	CON26 (X19)	1	+24V
	2	+V		2	+V		2	+V		2	+V
	3	24G		3	24G		3	24G		3	24G
	4	X1		4	X9		4	X11		4	X19
CON3 (X2)	1	+24V	CON11 (XA)	1	+24V	CON19 (X12)	1	+24V	CON27 (X1A)	1	+24V
	2	+V		2	+V		2	+V		2	+V
	3	24G		3	24G		3	24G		3	24G
	4	X2		4	XA		4	X12		4	X1A
CON4 (X3)	1	+24V	CON12 (XB)	1	+24V	CON20 (X13)	1	+24V	CON28 (X1B)	1	+24V
	2	+V		2	+V		2	+V		2	+V
	3	24G		3	24G		3	24G		3	24G
	4	X3		4	XB		4	X13		4	X1B
CON5 (X4)	1	+24V	CON13 (XC)	1	+24V	CON21 (X14)	1	+24V	CON29 (X1C)	1	+24V
	2	+V		2	+V		2	+V		2	+V
	3	24G		3	24G		3	24G		3	24G
	4	X4		4	XC		4	X14		4	X1C
CON6 (X5)	1	+24V	CON14 (XD)	1	+24V	CON22 (X15)	1	+24V	CON30 (X1D)	1	+24V
	2	+V		2	+V		2	+V		2	+V
	3	24G		3	24G		3	24G		3	24G
	4	X5		4	XD		4	X15		4	X1D
CON7 (X6)	1	+24V	CON15 (XE)	1	+24V	CON23 (X16)	1	+24V	CON31 (X1E)	1	+24V
	2	+V		2	+V		2	+V		2	+V
	3	24G		3	24G		3	24G		3	24G
	4	X6		4	XE		4	X16		4	X1E
CON8 (X7)	1	+24V	CON16 (XF)	1	+24V	CON24 (X17)	1	+24V	CON32 (X1F)	1	+24V
	2	+V		2	+V		2	+V		2	+V
	3	24G		3	24G		3	24G		3	24G
	4	X7		4	XF		4	X17		4	X1F

NZ2GN12A4-16D DC input module

Item		NZ2GN12A4-16D
Station type		Remote device station
Network topology		Line topology, star topology, mixture of star topology and line topology, ring topology
Number of input points		16 points
Rated input voltage		24VDC (ripple rate: 5% or less) (Allowable voltage range: 20.4 to 28.8VDC)
Rated input current		7.3mA TYP. (for 24VDC)
Maximum number of simultaneous input points		100%
ON voltage/ON current		11VDC or more/4mA or more
OFF voltage/OFF current		5VDC or less/1.5mA or less
Input resistance		3.0kΩ
Input response time	OFF → ON	0ms ^{*1} /0.2ms/1ms/1.5ms/5ms/10ms/20ms/70ms (Factory default: 10ms)
	ON → OFF	
Withstand voltage		720VDC for 1 minute between all DC external terminals and ground
Insulation resistance		10MΩ or higher between all DC external terminals and ground (500VDC insulation resistance tester)
Noise immunity ^{*2}		Noise voltage 500Vp-p, noise width 1μs, noise frequency 25 to 60Hz (DC type noise simulator condition)
Protection degree		IP67
Wiring method for common		16 points/common (2- to 4-wire, waterproof connector type) Positive common type
Current supplied to external devices		0.4A/terminal
External interface	Communication part	M12 waterproof connector, 8 pins, female, X-code
	Module power supply part	M12 waterproof connector, 5 pins, male, female, L-code
	I/O part	M12 waterproof connector, 5 pins, female, A-code
Applicable waterproof connector	For communications	☞ Page 147 List of Recommended Cables/Connectors for the I/O Module (Waterproof Module)
	For power supply	
	For I/O	
	Y-branch connector for I/O	
Multicast filter		Available
Cyclic transmission	RX/RY points	16 points
	RWr/RWw points	4 points ^{*3}
Module power supply ^{*4}	Voltage	24VDC (ripple rate: 5% or less) (Allowable voltage range: 20.4 to 28.8VDC)
	Current	250mA or less (24VDC, all points ON)
Weight		0.41kg

*1 If the input response time is set to "0ms", the actual input response time is 80μs at OFF → ON, and 160μs at ON → OFF.

*2 It is the noise immunity of when the input response time setting value is other than "0ms". Note that the module is easily affected by noise if "0ms" is set.

*3 This value indicates the number of points set by default when the module is dragged and dropped to the network map in the CC IE Field Configuration window. According to the function used, set an appropriate number of points. (☞ Page 220 Input module (16-point module))

*4 For a power supply to be connected to the waterproof I/O module (such as the module-and-sensor power supply or the load power supply and external power supply for output part), use the power supply that meets the following condition.
SELV (Safety Extra Low Voltage): Product with reinforced insulation from the hazardous potential part (60V or higher)

External wiring

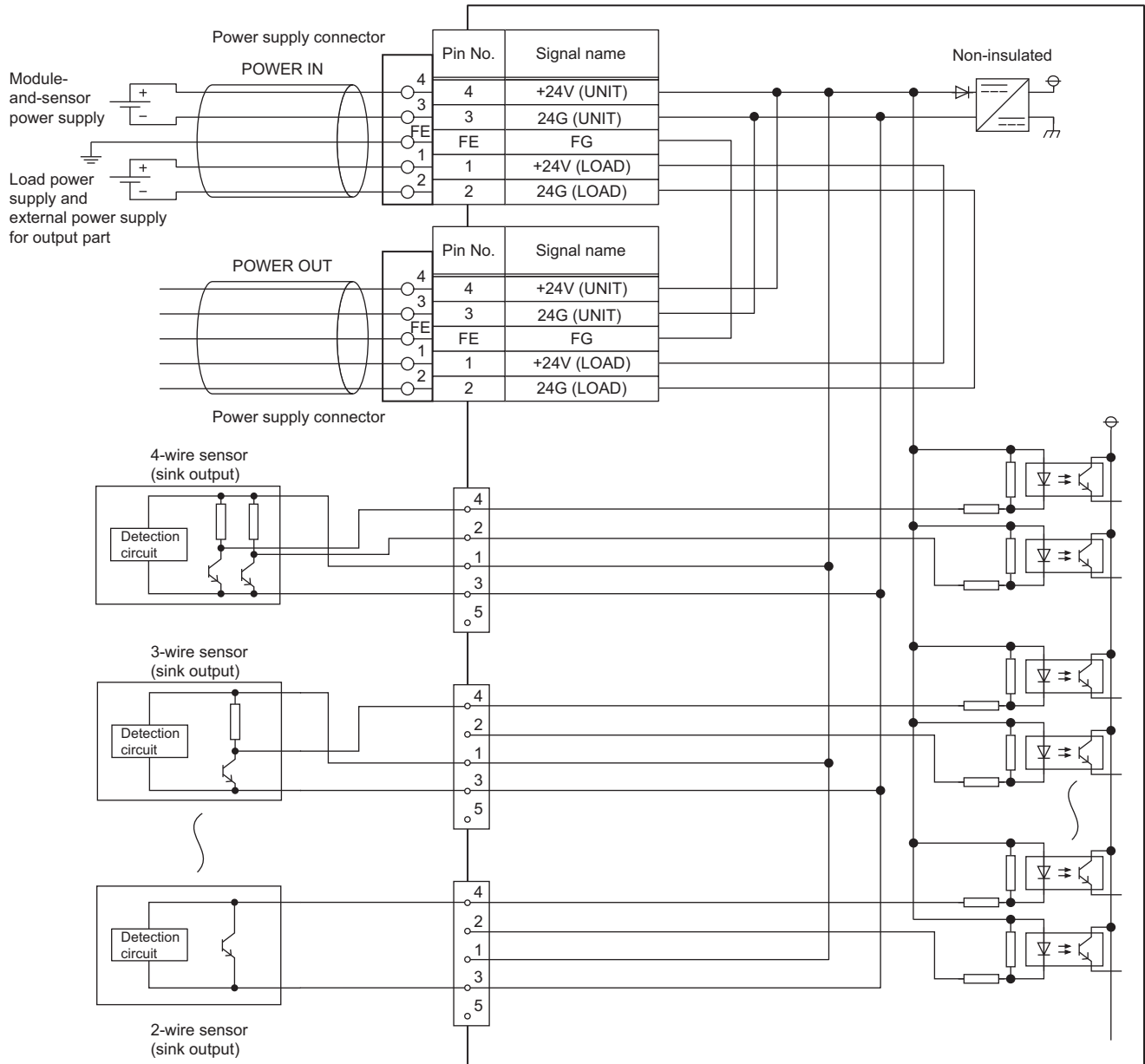

3

Power supply connectors

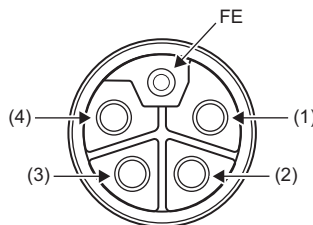
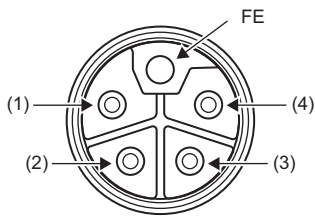

Pin number	Signal name	Pin number	Signal name		
M12 connector, male (IN)	(1)	+24V (LOAD)	M12 connector, female (OUT)	(1)	+24V (LOAD)
	(2)	24G (LOAD)		(2)	24G (LOAD)
	(3)	24G (UNIT)		(3)	24G (UNIT)
	(4)	+24V (UNIT)		(4)	+24V (UNIT)
	FE	FG		FE	FG

■ Connector for input

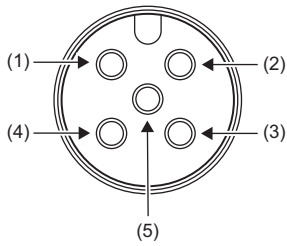

Pin number		Signal name	Pin number		Signal name
X0 X1	(1)	+24V (UNIT)	X8 X9	(1)	+24V (UNIT)
	(2)	X1		(2)	X9
	(3)	24G (UNIT)		(3)	24G (UNIT)
	(4)	X0		(4)	X8
	(5)	Empty		(5)	Empty
X2 X3	(1)	+24V (UNIT)	XA XB	(1)	+24V (UNIT)
	(2)	X3		(2)	XB
	(3)	24G (UNIT)		(3)	24G (UNIT)
	(4)	X2		(4)	XA
	(5)	Empty		(5)	Empty
X4 X5	(1)	+24V (UNIT)	XC XD	(1)	+24V (UNIT)
	(2)	X5		(2)	XD
	(3)	24G (UNIT)		(3)	24G (UNIT)
	(4)	X4		(4)	XC
	(5)	Empty		(5)	Empty
X6 X7	(1)	+24V (UNIT)	XE XF	(1)	+24V (UNIT)
	(2)	X7		(2)	XF
	(3)	24G (UNIT)		(3)	24G (UNIT)
	(4)	X6		(4)	XE
	(5)	Empty		(5)	Empty

NZ2GN12A4-16DE DC input module

Item		NZ2GN12A4-16DE
Station type		Remote device station
Network topology		Line topology, star topology, mixture of star topology and line topology, ring topology
Number of input points		16 points
Rated input voltage		24VDC (ripple rate: 5% or less) (Allowable voltage range: 20.4 to 28.8VDC)
Rated input current		7.3mA TYP. (for 24VDC)
Maximum number of simultaneous input points		100%
ON voltage/ON current		11VDC or more/4mA or more
OFF voltage/OFF current		5VDC or less/1.5mA or less
Input resistance		3.0k Ω
Input response time	OFF \rightarrow ON	0ms ^{*1} /0.2ms/1ms/1.5ms/5ms/10ms/20ms/70ms (Factory default: 10ms)
	ON \rightarrow OFF	
Withstand voltage		720VDC for 1 minute between all DC external terminals and ground
Insulation resistance		10M Ω or higher between all DC external terminals and ground (500VDC insulation resistance tester)
Noise immunity ^{*2}		Noise voltage 500Vp-p, noise width 1 μ s, noise frequency 25 to 60Hz (DC type noise simulator condition)
Protection degree		IP67
Wiring method for common		16 points/common (2- to 4-wire, waterproof connector type) Negative common type
Current supplied to external devices		0.4A/terminal
External interface	Communication part	M12 waterproof connector, 8 pins, female, X-code
	Module power supply part	M12 waterproof connector, 5 pins, male, female, L-code
	I/O part	M12 waterproof connector, 5 pins, female, A-code
Applicable waterproof connector	For communications	 Page 147 List of Recommended Cables/Connectors for the I/O Module (Waterproof Module)
	For power supply	
	For I/O	
	Y-branch connector for I/O	
Multicast filter		Available
Cyclic transmission	RX/RY points	16 points
	RWr/RWw points	4 points ^{*3}
Module power supply ^{*4}	Voltage	24VDC (ripple rate: 5% or less) (Allowable voltage range: 20.4 to 28.8VDC)
	Current	250mA or less (24VDC, all points ON)
Weight		0.41kg

*1 If the input response time is set to "0ms", the actual input response time is 80 μ s at OFF \rightarrow ON, and 160 μ s at ON \rightarrow OFF.

*2 It is the noise immunity of when the input response time setting value is other than "0ms". Note that the module is easily affected by noise if "0ms" is set.

*3 This value indicates the number of points set by default when the module is dragged and dropped to the network map in the CC IE Field Configuration window. According to the function used, set an appropriate number of points. ( Page 220 Input module (16-point module))

*4 For a power supply to be connected to the waterproof I/O module (such as the module-and-sensor power supply or the load power supply and external power supply for output part), use the power supply that meets the following condition.
SELV (Safety Extra Low Voltage): Product with reinforced insulation from the hazardous potential part (60V or higher)

External wiring

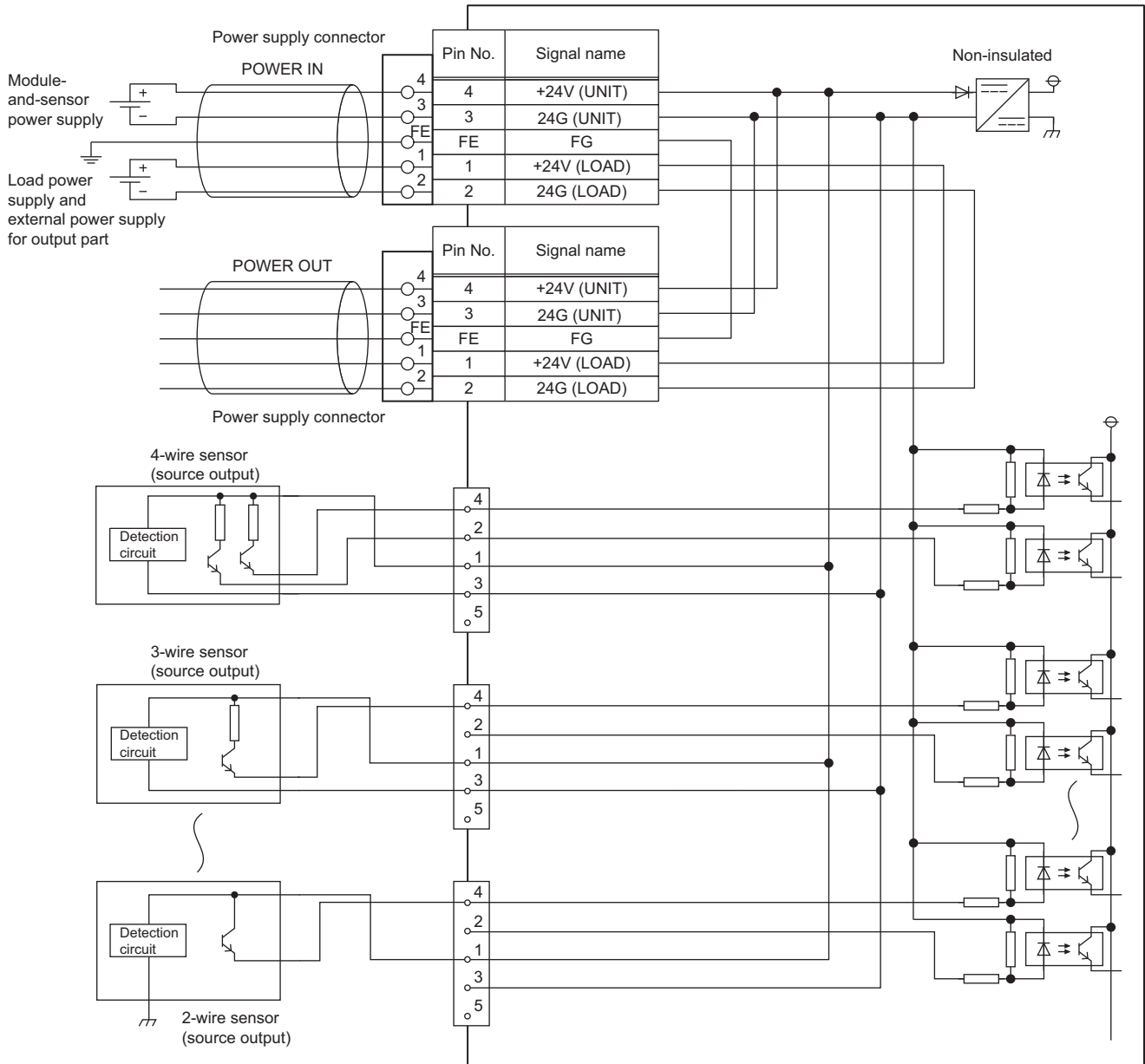

Power supply connectors

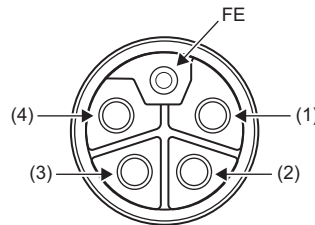
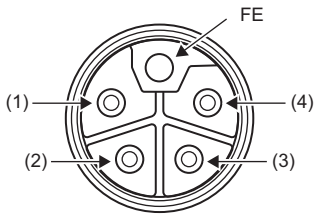

Pin number	Signal name	Pin number	Signal name
M12 connector, male (IN)	(1)	M12 connector, female (OUT)	(1)
	(2)		(2)
	(3)		(3)
	(4)		(4)
	FE		FE
	+24V (LOAD)		+24V (LOAD)
	24G (LOAD)		24G (LOAD)
	24G (UNIT)		24G (UNIT)
	+24V (UNIT)		+24V (UNIT)
	FG		FG

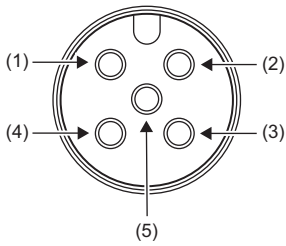

■ Connector for input



Pin number		Signal name	Pin number		Signal name
X0 X1	(1)	+24V (UNIT)	X8 X9	(1)	+24V (UNIT)
	(2)	X1		(2)	X9
	(3)	24G (UNIT)		(3)	24G (UNIT)
	(4)	X0		(4)	X8
	(5)	Empty		(5)	Empty
X2 X3	(1)	+24V (UNIT)	XA XB	(1)	+24V (UNIT)
	(2)	X3		(2)	XB
	(3)	24G (UNIT)		(3)	24G (UNIT)
	(4)	X2		(4)	XA
	(5)	Empty		(5)	Empty
X4 X5	(1)	+24V (UNIT)	XC XD	(1)	+24V (UNIT)
	(2)	X5		(2)	XD
	(3)	24G (UNIT)		(3)	24G (UNIT)
	(4)	X4		(4)	XC
	(5)	Empty		(5)	Empty
X6 X7	(1)	+24V (UNIT)	XE XF	(1)	+24V (UNIT)
	(2)	X7		(2)	XF
	(3)	24G (UNIT)		(3)	24G (UNIT)
	(4)	X6		(4)	XE
	(5)	Empty		(5)	Empty

Output module

NZ2GN2S1-16T transistor output module

Item		NZ2GN2S1-16T
Station type		Remote device station
Network topology		Line topology, star topology, mixture of star topology and line topology, ring topology
Number of output points		16 points
Rated load voltage		12/24VDC (ripple rate: 5% or less) (Allowable voltage range: 10.2 to 28.8VDC)
Max. load current		0.5A/point, 4A/common
Maximum inrush current		Current is limited by the overload protection function.
Leakage current at OFF		0.1mA or less
Max. voltage drop at ON		0.3VDC (TYP.) 0.5A, 0.6VDC (MAX.) 0.5A
Output response time	OFF → ON	0.1ms or less
	ON → OFF	0.8ms or less (resistive load)
Surge suppressor		Zener diode
External power supply for output part	Voltage	12/24VDC (ripple rate: 5% or less) (Allowable voltage range: 10.2 to 28.8VDC)
	Current	40mA or less (TYP. 24VDC per common) External load current is not included.
Withstand voltage		510VAC for 1 minute between all DC external terminals and ground
Insulation resistance		10MΩ or higher between all DC external terminals and ground (500VDC insulation resistance tester)
Noise immunity		Noise voltage 500Vp-p, noise width 1μs, noise frequency 25 to 60Hz (DC type noise simulator condition)
Protection degree		IP2X
Wiring method for common		16 points/common (Common terminal: terminal number 18) (1-wire, spring clamp terminal block type) Sink type
Protection function	Overload protection function	Limited current when detecting overcurrent: 1.5 to 3.5A/point Activated to each point.
	Overheat protection function	Activated to each point.
External interface	Communication part	RJ45 connector
	Module power supply part	Terminal block for module power supply and FG (2-piece spring clamp terminal block)
	I/O part	18-point two-piece spring clamp terminal block
Applicable wire size	For power supply	Stranded wire: 0.3 to 1.5mm ² (22 to 16 AWG), terminal slot size: 2.4mm × 1.5mm ^{*1}
	For I/O	Stranded wire: 0.3 to 1.5mm ² (22 to 16 AWG)
Applicable solderless terminal ^{*2}	Terminal block for module power supply and FG	 Page 124 Applicable solderless terminal
	Terminal block for output	 Page 134 Applicable solderless terminal
Multicast filter		Available
Cyclic transmission	RX/RV points	16 points
	RWw/RWw points	4 points ^{*3}
Module power supply	Voltage	24VDC (ripple rate: 5% or less) (Allowable voltage range: 20.4 to 28.8VDC)
	Current	110mA or less (24VDC, all points ON)
Weight		0.15kg

*1 Use bar solderless terminals for wiring.

*2 Only one wire can be inserted into a wire insertion opening. Multiple wires cannot be connected to a terminal. Connecting two or more wires may cause a poor contact.

*3 This value indicates the number of points set by default when the module is dragged and dropped to the network map in the CC IE Field Configuration window. According to the function used, set an appropriate number of points. ( Page 222 Output module (16-point module))

External wiring

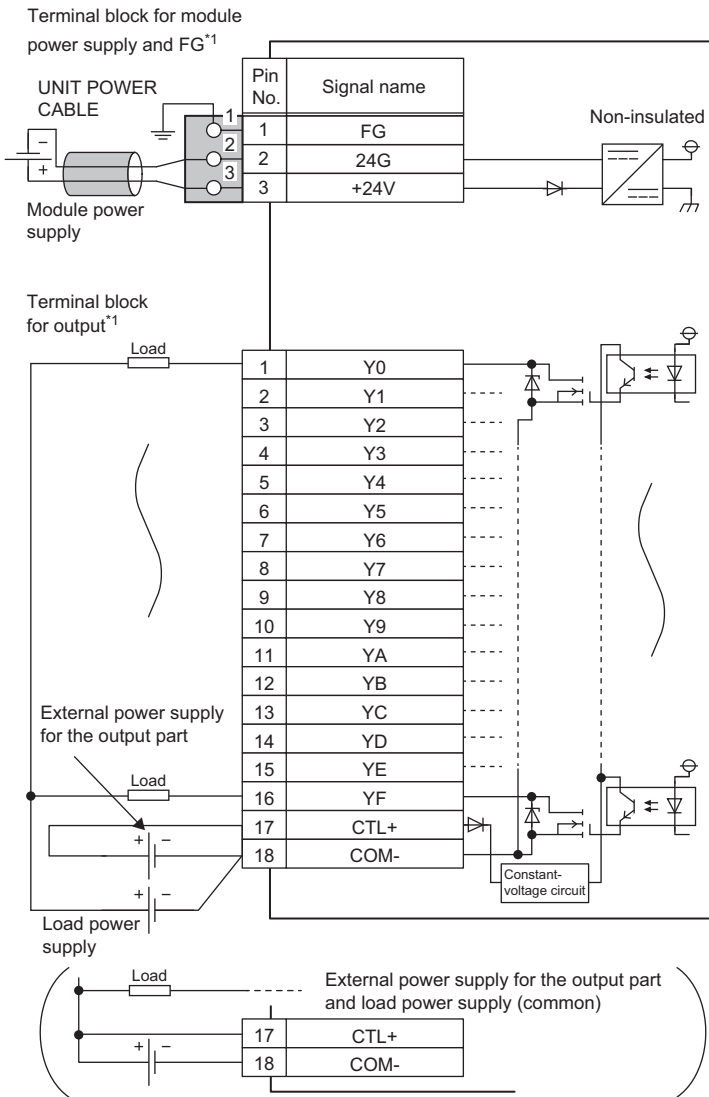

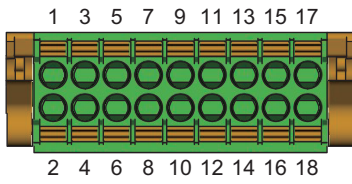

*1 Only one wire can be inserted into a wire insertion opening. Multiple wires cannot be connected to a terminal. Connecting two or more wires may cause a poor contact.

■ Terminal block for output



Terminal number	Signal name
1	Y0
2	Y1
3	Y2
4	Y3
5	Y4
6	Y5
7	Y6
8	Y7
9	Y8
10	Y9
11	YA
12	YB
13	YC
14	YD
15	YE
16	YF
17	CTL+
18	COM-

NZ2GN2S1-32T transistor output module

Item		NZ2GN2S1-32T
Station type		Intelligent device station
Network topology		Line topology, star topology, mixture of star topology and line topology, ring topology
Number of output points		32 points
Rated load voltage		12/24VDC (ripple rate: 5% or less) (Allowable voltage range: 10.2 to 28.8VDC)
Max. load current		0.5A/point, 5A/common
Maximum inrush current		Current is limited by the overload protection function.
Leakage current at OFF		0.1mA or less
Max. voltage drop at ON		0.3VDC (TYP.) 0.5A, 0.6VDC (MAX.) 0.5A
Output response time	OFF → ON	0.1ms or less
	ON → OFF	0.8ms or less (resistive load)
Surge suppressor		Zener diode
External power supply for output part	Voltage	12/24VDC (ripple rate: 5% or less) (Allowable voltage range: 10.2 to 28.8VDC)
	Current	40mA or less (TYP. 24VDC per common) External load current is not included.
Withstand voltage		510VAC for 1 minute between all DC external terminals and ground
Insulation resistance		10MΩ or higher between all DC external terminals and ground (500VDC insulation resistance tester)
Noise immunity		Noise voltage 500Vp-p, noise width 1μs, noise frequency 25 to 60Hz (DC type noise simulator condition)
Protection degree		IP2X
Wiring method for common		32 points/common (Common terminal: terminal number 34) (1-wire, spring clamp terminal block type) Sink type
Protection function	Overload protection function	Limited current when detecting overcurrent: 1.5 to 3.5A/point Activated to each point.
	Overheat protection function	Activated to each point.
External interface	Communication part	RJ45 connector
	Module power supply part	Terminal block for module power supply and FG (2-piece spring clamp terminal block)
	I/O part	2-piece spring clamp terminal block
Applicable wire size	For power supply	Stranded wire: 0.3 to 1.5mm ² (22 to 16 AWG), terminal slot size: 2.4mm × 1.5mm ^{*1}
	For I/O	Stranded wire: 0.3 to 1.5mm ² (22 to 16 AWG)
Applicable solderless terminal ^{*2}	Terminal block for module power supply and FG	 Page 124 Applicable solderless terminal
	Terminal block for output	 Page 134 Applicable solderless terminal
Cyclic transmission	RX/RX points	32 points
	RWr/RWw points	4 points ^{*3}
Module power supply	Voltage	24VDC (ripple rate: 5% or less) (Allowable voltage range: 20.4 to 28.8VDC)
	Current	120mA or less (24VDC, all points ON)
Weight		0.18kg

*1 Use bar solderless terminals for wiring.

*2 Only one wire can be inserted into a wire insertion opening. Multiple wires cannot be connected to a terminal. Connecting two or more wires may cause a poor contact.

*3 This value indicates the number of points set by default when the module is dragged and dropped to the network map in the CC IE Field Configuration window. According to the function used, set an appropriate number of points. ( Page 223 Output module (32-point module))

External wiring

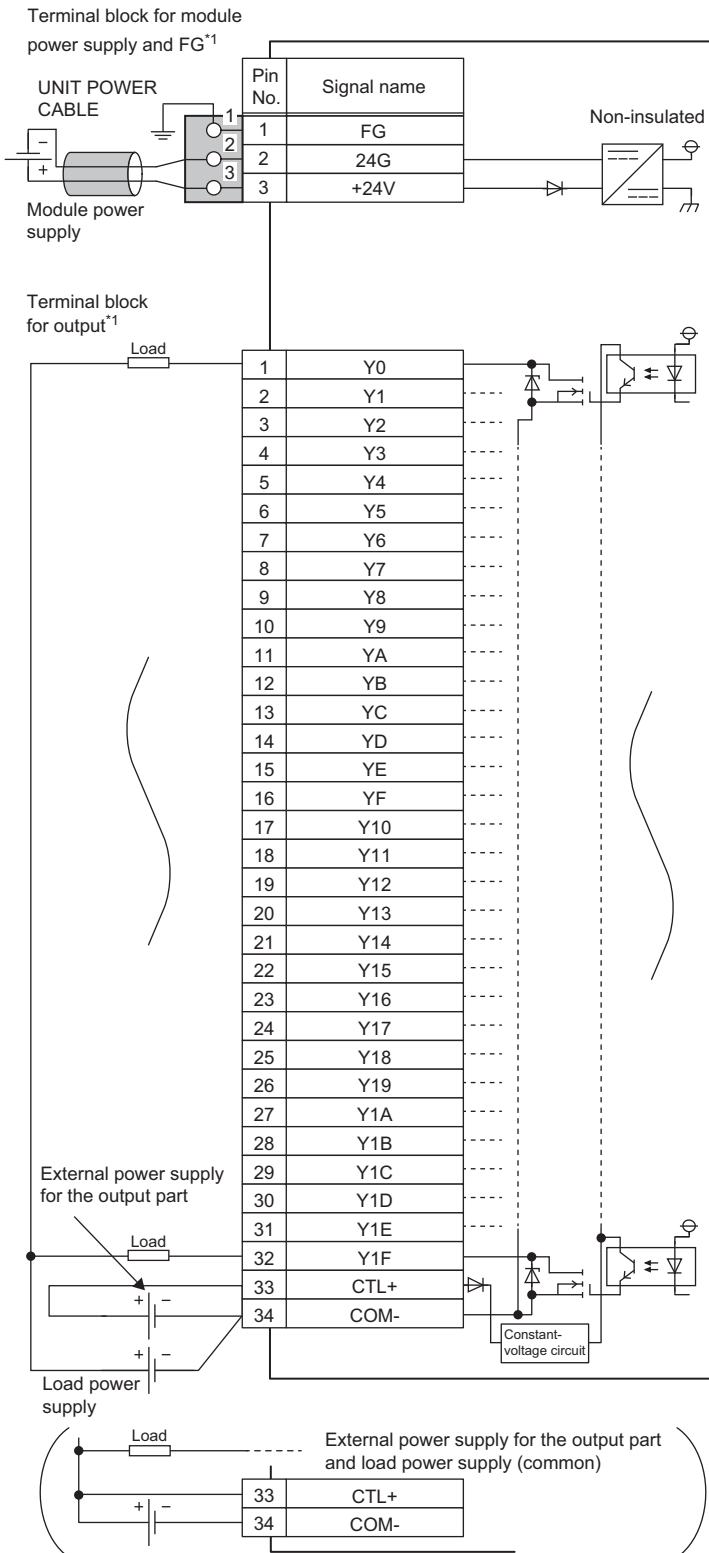

*1 Only one wire can be inserted into a wire insertion opening. Multiple wires cannot be connected to a terminal. Connecting two or more wires may cause a poor contact.

Terminal block for output

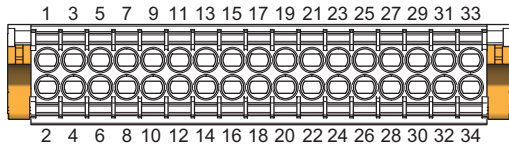

Terminal number	Signal name	Terminal number	Signal name
1	Y0	17	Y10
2	Y1	18	Y11
3	Y2	19	Y12
4	Y3	20	Y13
5	Y4	21	Y14
6	Y5	22	Y15
7	Y6	23	Y16
8	Y7	24	Y17
9	Y8	25	Y18
10	Y9	26	Y19
11	YA	27	Y1A
12	YB	28	Y1B
13	YC	29	Y1C
14	YD	30	Y1D
15	YE	31	Y1E
16	YF	32	Y1F
—		33	CTL+
		34	COM-

NZ2GN2B1-16T transistor output module

Item		NZ2GN2B1-16T
Station type		Remote device station
Network topology		Line topology, star topology, mixture of star topology and line topology, ring topology
Number of output points		16 points
Rated load voltage		12/24VDC (ripple rate: 5% or less) (Allowable voltage range: 10.2 to 28.8VDC)
Max. load current		0.5A/point, 4A/common
Maximum inrush current		Current is limited by the overload protection function.
Leakage current at OFF		0.1mA or less
Max. voltage drop at ON		0.3VDC (TYP.) 0.5A, 0.6VDC (MAX.) 0.5A
Output response time	OFF → ON	0.1ms or less
	ON → OFF	0.8ms or less (resistive load)
Surge suppressor		Zener diode
External power supply for output part	Voltage	12/24VDC (ripple rate: 5% or less) (Allowable voltage range: 10.2 to 28.8VDC)
	Current	40mA or less (TYP. 24VDC per common) External load current is not included.
Withstand voltage		510VAC for 1 minute between all DC external terminals and ground
Insulation resistance		10MΩ or higher between all DC external terminals and ground (500VDC insulation resistance tester)
Noise immunity		Noise voltage 500Vp-p, noise width 1μs, noise frequency 25 to 60Hz (DC type noise simulator condition)
Protection degree		IP2X
Wiring method for common		16 points/common (Common terminal: terminal number 18) (1-wire, screw terminal block type) Sink type
Protection function	Overload protection function	Limited current when detecting overcurrent: 1.5 to 3.5A/point Activated to each point.
	Overheat protection function	Activated to each point.
External interface	Communication part	RJ45 connector
	Module power supply part	Terminal block for module power supply and FG (2-piece spring clamp terminal block)
	I/O part	18-point two-piece terminal block Tightening torque range for terminal screw (M3 × 5.2 screw): 0.43 to 0.57N·m Tightening torque range for terminal block mounting screw (M3.5 screw): 0.68 to 0.92N·m
Applicable wire size	For power supply	Stranded wire: 0.3 to 1.5mm ² (22 to 16 AWG), terminal slot size: 2.4mm × 1.5mm ^{*1}
	For I/O	Stranded wire: 0.3 to 2.0mm ² (22 to 14 AWG)
Applicable solderless terminal	Terminal block for module power supply and FG ^{*2}	☞ Page 124 Applicable solderless terminal
	Terminal block for output	☞ Page 138 Applicable solderless terminal
Multicast filter		Available
Cyclic transmission	RX/RV points	16 points
	RWr/RVw points	4 points ^{*3}
Module power supply	Voltage	24VDC (ripple rate: 5% or less) (Allowable voltage range: 20.4 to 28.8VDC)
	Current	110mA or less (24VDC, all points ON)
Weight		0.21kg

*1 Use bar solderless terminals for wiring.

*2 Only one wire can be inserted into a wire insertion opening for the terminal block for module power supply and FG. Multiple wires cannot be connected to a terminal. Connecting two or more wires may cause a poor contact.

*3 This value indicates the number of points set by default when the module is dragged and dropped to the network map in the CC IE Field Configuration window. According to the function used, set an appropriate number of points. (☞ Page 222 Output module (16-point module))

External wiring

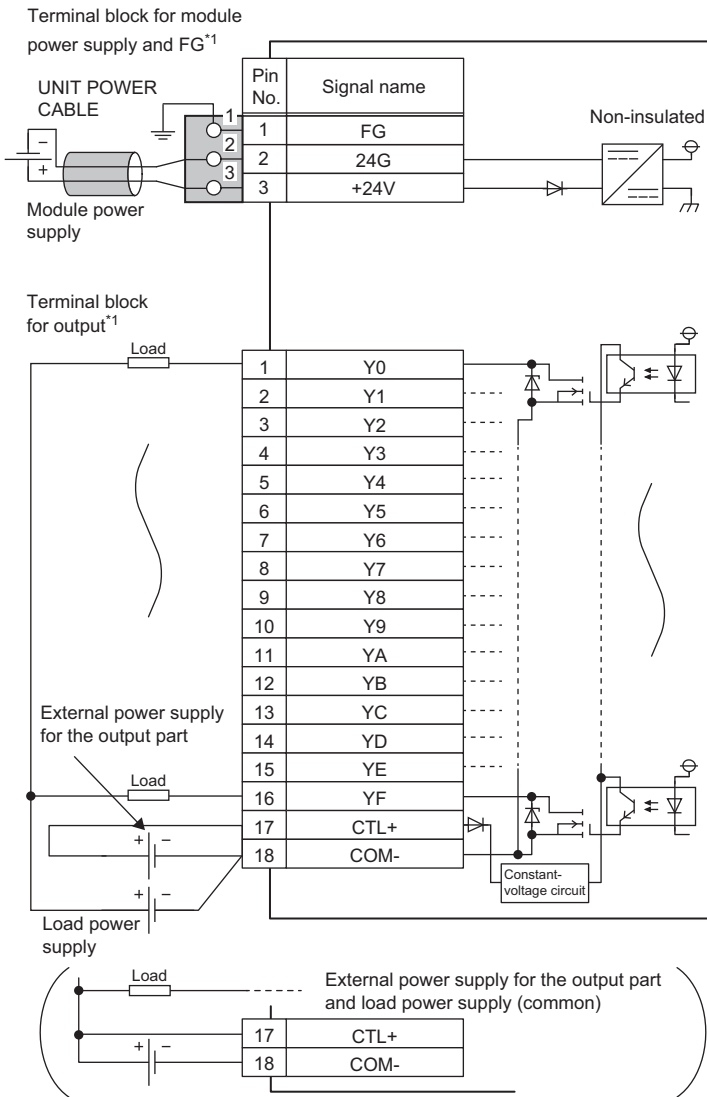

*1 Only one wire can be inserted into a wire insertion opening for the terminal block for module power supply and FG. Multiple wires cannot be connected to a terminal. Connecting two or more wires may cause a poor contact.

■ Terminal block for output

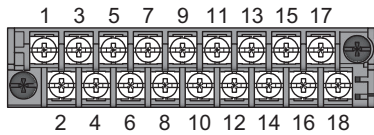

Terminal number	Signal name
1	Y0
2	Y1
3	Y2
4	Y3
5	Y4
6	Y5
7	Y6
8	Y7
9	Y8
10	Y9
11	YA
12	YB
13	YC
14	YD
15	YE
16	YF
17	CTL+
18	COM-

NZ2GN2B1-32T transistor output module

Item		NZ2GN2B1-32T
Station type		Intelligent device station
Network topology		Line topology, star topology, mixture of star topology and line topology, ring topology
Number of output points		32 points
Rated load voltage		12/24VDC (ripple rate: 5% or less) (Allowable voltage range: 10.2 to 28.8VDC)
Max. load current		0.5A/point, 5A/common
Maximum inrush current		Current is limited by the overload protection function.
Leakage current at OFF		0.1mA or less
Max. voltage drop at ON		0.3VDC (TYP.) 0.5A, 0.6VDC (MAX.) 0.5A
Output response time	OFF → ON	0.1ms or less
	ON → OFF	0.8ms or less (resistive load)
Surge suppressor		Zener diode
External power supply for output part	Voltage	12/24VDC (ripple rate: 5% or less) (Allowable voltage range: 10.2 to 28.8VDC)
	Current	40mA or less (TYP. 24VDC per common) External load current is not included.
Withstand voltage		510VAC for 1 minute between all DC external terminals and ground
Insulation resistance		10MΩ or higher between all DC external terminals and ground (500VDC insulation resistance tester)
Noise immunity		Noise voltage 500Vp-p, noise width 1μs, noise frequency 25 to 60Hz (DC type noise simulator condition)
Protection degree		IP2X
Wiring method for common		32 points/common (Common terminal: terminal number 34) (1-wire, screw terminal block type) Sink type
Protection function	Overload protection function	Limited current when detecting overcurrent: 1.5 to 3.5A/point Activated to each point.
	Overheat protection function	Activated to each point.
External interface	Communication part	RJ45 connector
	Module power supply part	Terminal block for module power supply and FG (2-piece spring clamp terminal block)
	I/O part	34-point two-piece terminal block Tightening torque range for terminal screw (M3 × 5.2 screw): 0.43 to 0.57N·m Tightening torque range for terminal block mounting screw (M3.5 screw): 0.68 to 0.92N·m
Applicable wire size	For power supply	Stranded wire: 0.3 to 1.5mm ² (22 to 16 AWG), terminal slot size: 2.4mm × 1.5mm ^{*1}
	For I/O	Stranded wire: 0.3 to 2.0mm ² (22 to 14 AWG)
Applicable solderless terminal	Terminal block for module power supply and FG ^{*2}	☞ Page 124 Applicable solderless terminal
	Terminal block for output	☞ Page 138 Applicable solderless terminal
Cyclic transmission	RX/Ry points	32 points
	RWr/RWw points	4 points ^{*3}
Module power supply	Voltage	24VDC (ripple rate: 5% or less) (Allowable voltage range: 20.4 to 28.8VDC)
	Current	120mA or less (24VDC, all points ON)
Weight		0.29kg

*1 Use bar solderless terminals for wiring.

*2 Only one wire can be inserted into a wire insertion opening for the terminal block for module power supply and FG. Multiple wires cannot be connected to a terminal. Connecting two or more wires may cause a poor contact.

*3 This value indicates the number of points set by default when the module is dragged and dropped to the network map in the CC IE Field Configuration window. According to the function used, set an appropriate number of points. (☞ Page 223 Output module (32-point module))

External wiring

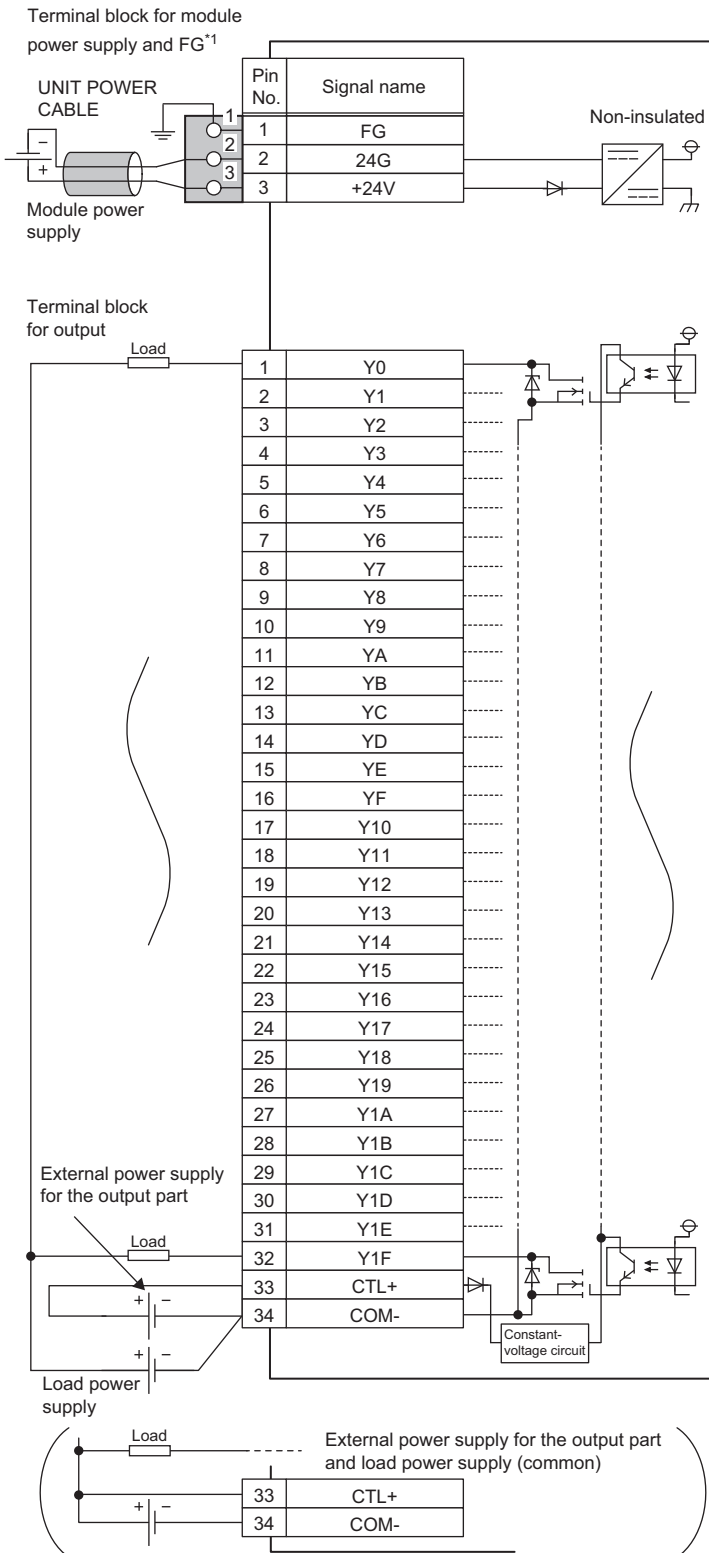

*1 Only one wire can be inserted into a wire insertion opening for the terminal block for module power supply and FG. Multiple wires cannot be connected to a terminal. Connecting two or more wires may cause a poor contact.

Terminal block for output

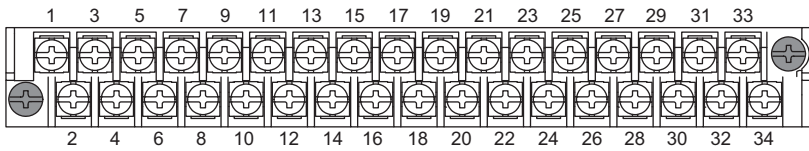

Terminal number	Signal name	Terminal number	Signal name
1	Y0	17	Y10
2	Y1	18	Y11
3	Y2	19	Y12
4	Y3	20	Y13
5	Y4	21	Y14
6	Y5	22	Y15
7	Y6	23	Y16
8	Y7	24	Y17
9	Y8	25	Y18
10	Y9	26	Y19
11	YA	27	Y1A
12	YB	28	Y1B
13	YC	29	Y1C
14	YD	30	Y1D
15	YE	31	Y1E
16	YF	32	Y1F
—		33	CTL+
		34	COM-

NZ2GNCF1-32T transistor output module

Item		NZ2GNCF1-32T
Station type		Intelligent device station
Network topology		Line topology, star topology, mixture of star topology and line topology, ring topology
Number of output points		32 points
Rated load voltage		12/24VDC (ripple rate: 5% or less) (Allowable voltage range: 10.2 to 28.8VDC)
Max. load current		0.1A/point, 3.2A/common
Maximum inrush current		Current is limited by the overload protection function.
Leakage current at OFF		0.1mA or less
Max. voltage drop at ON		0.1VDC (TYP.) 0.1A, 0.2VDC (MAX.) 0.1A
Output response time	OFF → ON	0.1ms or less
	ON → OFF	0.8ms or less (resistive load)
Surge suppressor		Zener diode
External power supply for output part	Voltage	12/24VDC (ripple rate: 5% or less) (Allowable voltage range: 10.2 to 28.8VDC)
	Current	40mA or less (TYP. 24VDC per common) External load current is not included.
Withstand voltage		510VAC for 1 minute between all DC external terminals and ground
Insulation resistance		10MΩ or higher between all DC external terminals and ground (500VDC insulation resistance tester)
Noise immunity		Noise voltage 500Vp-p, noise width 1μs, noise frequency 25 to 60Hz (DC type noise simulator condition)
Protection degree		IP2X
Wiring method for common		32 points/common (Common terminal: pin number A1, A2) (1-wire, 40-pin connector type) Sink type
Protection function	Overload protection function	Limited current when detecting overcurrent: 1 to 3A/point Activated to each point.
	Overheat protection function	Activated to each point.
External interface	Communication part	RJ45 connector
	Module power supply part	Terminal block for module power supply and FG (2-piece spring clamp terminal block)
	I/O part	40-pin connector
Applicable wire size	For power supply	Stranded wire: 0.3 to 1.5mm ² (22 to 16 AWG), terminal slot size: 2.4mm × 1.5mm ^{*1}
	For I/O	40-pin connector The size depends on the connector plug used (sold separately). (☞ Page 140 Wiring of 40-pin connector)
Applicable solderless terminal ^{*2}	Terminal block for module power supply and FG	☞ Page 124 Applicable solderless terminal
Cyclic transmission	RX/RV points	32 points
	RW/RVw points	4 points ^{*3}
Module power supply	Voltage	24VDC (ripple rate: 5% or less) (Allowable voltage range: 20.4 to 28.8VDC)
	Current	120mA or less (24VDC, all points ON)
Weight		0.16kg

*1 Use bar solderless terminals for wiring.

*2 Only one wire can be inserted into a wire insertion opening for the terminal block for module power supply and FG. Multiple wires cannot be connected to a terminal. Connecting two or more wires may cause a poor contact.

*3 This value indicates the number of points set by default when the module is dragged and dropped to the network map in the CC IE Field Configuration window. According to the function used, set an appropriate number of points. (☞ Page 223 Output module (32-point module))

External wiring

Terminal block for module power supply and FG^{*1}

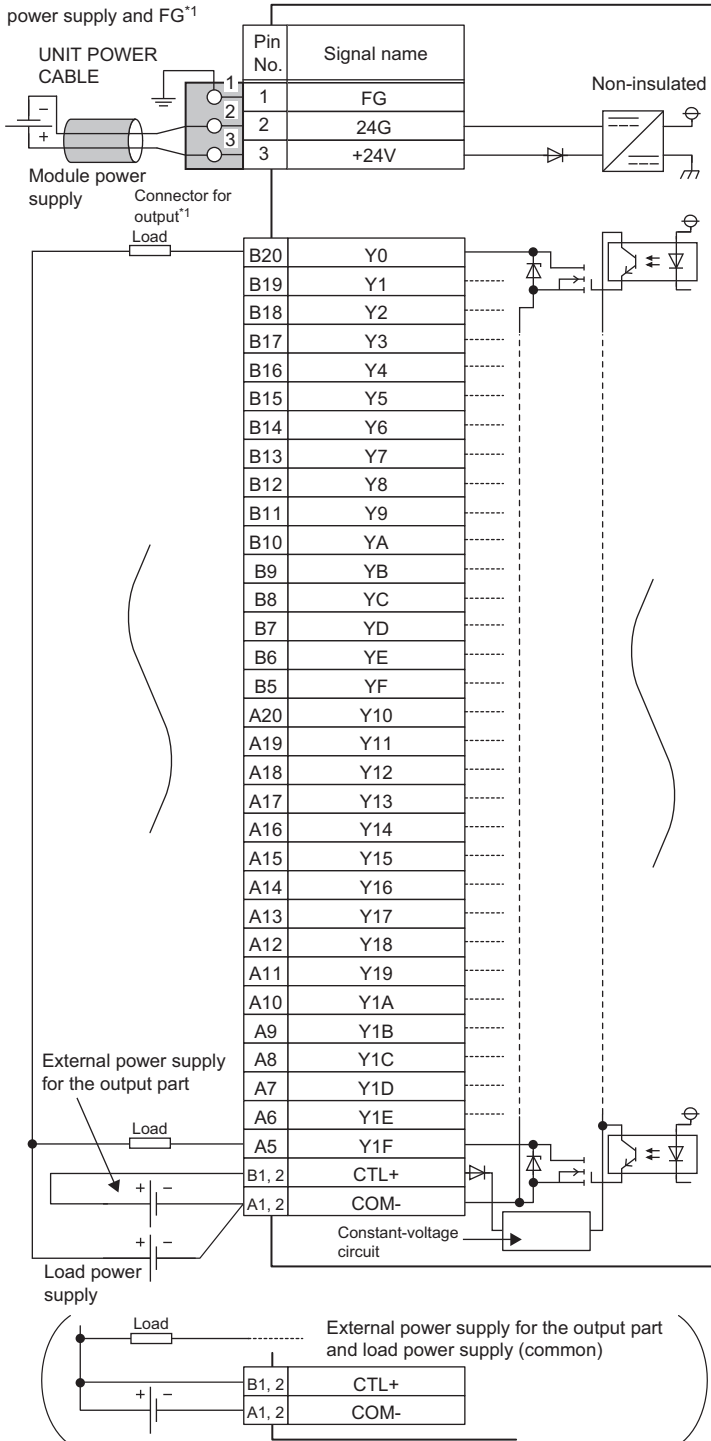

*1 Only one wire can be inserted into a wire insertion opening for the following: terminal block for module power supply and FG, connector for output. Multiple wires cannot be connected to a terminal. Connecting two or more wires may cause a poor contact.

■ Connector for output

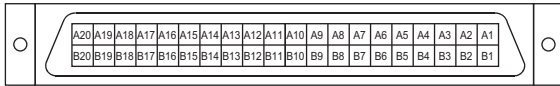

Terminal number	Signal name	Terminal number	Signal name
B20	Y0	A20	Y10
B19	Y1	A19	Y11
B18	Y2	A18	Y12
B17	Y3	A17	Y13
B16	Y4	A16	Y14
B15	Y5	A15	Y15
B14	Y6	A14	Y16
B13	Y7	A13	Y17
B12	Y8	A12	Y18
B11	Y9	A11	Y19
B10	YA	A10	Y1A
B9	YB	A9	Y1B
B8	YC	A8	Y1C
B7	YD	A7	Y1D
B6	YE	A6	Y1E
B5	YF	A5	Y1F
B4	Empty	A4	Empty
B3	Empty	A3	Empty
B2	CTL+	A2	COM-
B1	CTL+	A1	COM-

NZ2GN12A2-16T transistor output module

Item		NZ2GN12A2-16T
Station type		Remote device station
Network topology		Line topology, star topology, mixture of star topology and line topology, ring topology
Number of output points		16 points
Rated load voltage		12/24VDC (ripple rate: 5% or less) (Allowable voltage range: 10.2 to 28.8VDC)
Max. load current		4A/point (Y0 to Y3) ^{*1} , 2A/point (Y4 to YF), 12A/common
Maximum inrush current		Current is limited by the overload protection function.
Leakage current at OFF		0.1mA or less
Max. voltage drop at ON		0.25VDC (TYP.) 2A, 0.5VDC (MAX.) 2A, 0.5VDC (TYP.) 4A, 0.1VDC (MAX.) 4A
Output response time	OFF → ON	0.5ms or less
	ON → OFF	0.8ms or less (resistive load)
Surge suppressor		Zener diode
External power supply for output part ^{*3}	Voltage	12/24VDC (ripple rate: 5% or less) (Allowable voltage range: 10.2 to 28.8VDC)
	Current	25mA or less (TYP. 24VDC per common) External load current is not included.
Withstand voltage		720VDC for 1 minute between all DC external terminals and ground
Insulation resistance		10MΩ or higher between all DC external terminals and ground (500VDC insulation resistance tester)
Noise immunity		Noise voltage 500Vp-p, noise width 1μs, noise frequency 25 to 60Hz (DC type noise simulator condition)
Protection degree		IP67
Wiring method for common		16 points/common (2-wire, waterproof connector type) Sink type
Protection function	Overload protection function	Limited current when detecting overcurrent: 9A or more/point Activated to each point.
	Overheat protection function	Activated to each point.
External interface	Communication part	M12 waterproof connector, 8 pins, female, X-code
	Module power supply part	M12 waterproof connector, 5 pins, male, female, L-code
	I/O part	M12 waterproof connector, 5 pins, female, A-code
Applicable waterproof connector	For communications	☞ Page 147 List of Recommended Cables/Connectors for the I/O Module (Waterproof Module)
	For power supply	
	For I/O	
	Y-branch connector for I/O	
Multicast filter		Available
Cyclic transmission	RX/Ry points	16 points
	RWw/RWw points	4 points ^{*2}
Module power supply ^{*3}	Voltage	24VDC (ripple rate: 5% or less) (Allowable voltage range: 20.4 to 28.8VDC)
	Current	110mA or less (24VDC, all points ON)
Weight		0.42kg

*1 Make sure that the total amount of output current that flows through one connector is 4A or less.

*2 This value indicates the number of points set by default when the module is dragged and dropped to the network map in the CC IE Field Configuration window. According to the function used, set an appropriate number of points. (☞ Page 222 Output module (16-point module))

*3 For a power supply to be connected to the waterproof I/O module (such as the module-and-sensor power supply or the load power supply and external power supply for output part), use the power supply that meets the following condition.
SELV (Safety Extra Low Voltage): Product with reinforced insulation from the hazardous potential part (60V or higher)

Derating chart

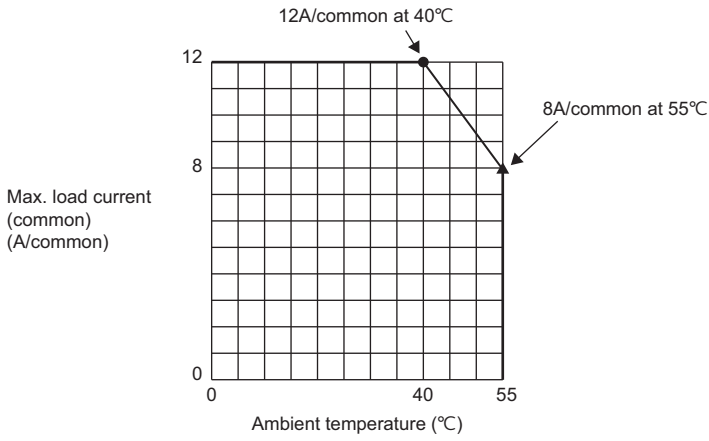

●: Module-and-sensor power supply current, 8A

▲: Module-and-sensor power supply current, 6A

The module-and-sensor power supply current is 6A when the ambient temperature is 40°C or higher.

External wiring

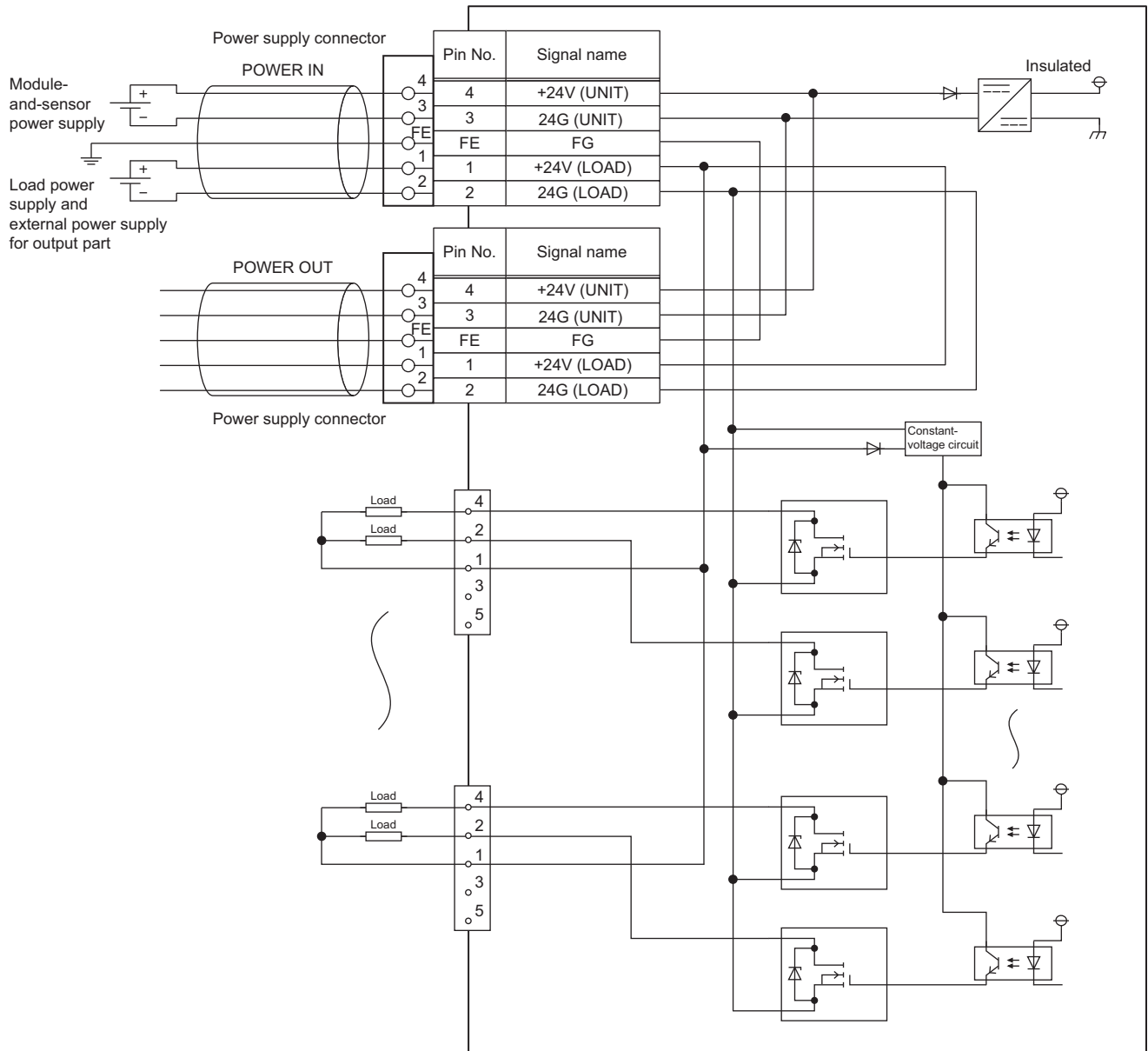

■ Power supply connectors

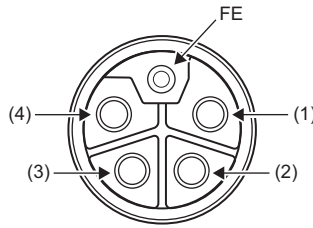
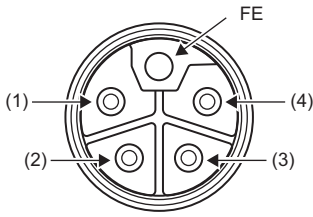

Pin number		Signal name	Pin number		Signal name
M12 connector, male (IN)	(1)	+24V (LOAD)	M12 connector, female (OUT)	(1)	+24V (LOAD)
	(2)	24G (LOAD)		(2)	24G (LOAD)
	(3)	24G (UNIT)		(3)	24G (UNIT)
	(4)	+24V (UNIT)		(4)	+24V (UNIT)
	FE	FG		FE	FG

■ Connector for output

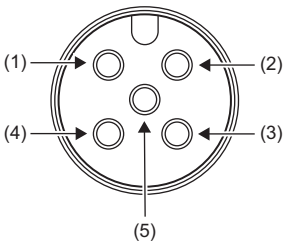

Pin number		Signal name	Pin number		Signal name
Y0 Y1	(1)	+24V (LOAD)	Y8 Y9	(1)	+24V (LOAD)
	(2)	Y1		(2)	Y9
	(3)	Empty		(3)	Empty
	(4)	Y0		(4)	Y8
	(5)	Empty		(5)	Empty
Y2 Y3	(1)	+24V (LOAD)	YA YB	(1)	+24V (LOAD)
	(2)	Y3		(2)	YB
	(3)	Empty		(3)	Empty
	(4)	Y2		(4)	YA
	(5)	Empty		(5)	Empty
Y4 Y5	(1)	+24V (LOAD)	YC YD	(1)	+24V (LOAD)
	(2)	Y5		(2)	YD
	(3)	Empty		(3)	Empty
	(4)	Y4		(4)	YC
	(5)	Empty		(5)	Empty
Y6 Y7	(1)	+24V (LOAD)	YE YF	(1)	+24V (LOAD)
	(2)	Y7		(2)	YF
	(3)	Empty		(3)	Empty
	(4)	Y6		(4)	YE
	(5)	Empty		(5)	Empty

NZ2GN2S1-16TE transistor output module

Item		NZ2GN2S1-16TE
Station type		Remote device station
Network topology		Line topology, star topology, mixture of star topology and line topology, ring topology
Number of output points		16 points
Rated load voltage		12/24VDC (ripple rate: 5% or less) (Allowable voltage range: 10.2 to 28.8VDC)
Max. load current		0.5A/point, 4A/common
Maximum inrush current		Current is limited by the overload protection function.
Leakage current at OFF		0.1mA or less
Max. voltage drop at ON		0.5VDC (TYP.) 0.5A, 0.8VDC (MAX.) 0.5A
Output response time	OFF → ON	0.5ms or less
	ON → OFF	1.0ms or less (resistive load)
Surge suppressor		Zener diode
External power supply for output part	Voltage	12/24VDC (ripple rate: 5% or less) (Allowable voltage range: 10.2 to 28.8VDC)
	Current	80mA or less (TYP. 24VDC per common) External load current is not included.
Withstand voltage		510VAC for 1 minute between all DC external terminals and ground
Insulation resistance		10MΩ or higher between all DC external terminals and ground (500VDC insulation resistance tester)
Noise immunity		Noise voltage 500Vp-p, noise width 1μs, noise frequency 25 to 60Hz (DC type noise simulator condition)
Protection degree		IP2X
Wiring method for common		16 points/common (Common terminal: terminal number 17) (1-wire, spring clamp terminal block type) Source type
Protection function	Overload protection function	Limited current when detecting overcurrent: 1.5A or more/point Activated to each point.
	Overheat protection function	Activated to each point.
External interface	Communication part	RJ45 connector
	Module power supply part	Terminal block for module power supply and FG (2-piece spring clamp terminal block)
	I/O part	18-point two-piece spring clamp terminal block
Applicable wire size	For power supply	Stranded wire: 0.3 to 1.5mm ² (22 to 16 AWG), terminal slot size: 2.4mm × 1.5mm ^{*1}
	For I/O	Stranded wire: 0.3 to 1.5mm ² (22 to 16 AWG)
Applicable solderless terminal ^{*2}	Terminal block for module power supply and FG	☞ Page 124 Applicable solderless terminal
	Terminal block for output	☞ Page 134 Applicable solderless terminal
Multicast filter		Available
Cyclic transmission	RX/Ry points	16 points
	RWr/RWw points	4 points ^{*3}
Module power supply	Voltage	24VDC (ripple rate: 5% or less) (Allowable voltage range: 20.4 to 28.8VDC)
	Current	110mA or less (24VDC, all points ON)
Weight		0.15kg

*1 Use bar solderless terminals for wiring.

*2 Only one wire can be inserted into a wire insertion opening. Multiple wires cannot be connected to a terminal. Connecting two or more wires may cause a poor contact.

*3 This value indicates the number of points set by default when the module is dragged and dropped to the network map in the CC IE Field Configuration window. According to the function used, set an appropriate number of points. (☞ Page 222 Output module (16-point module))

External wiring

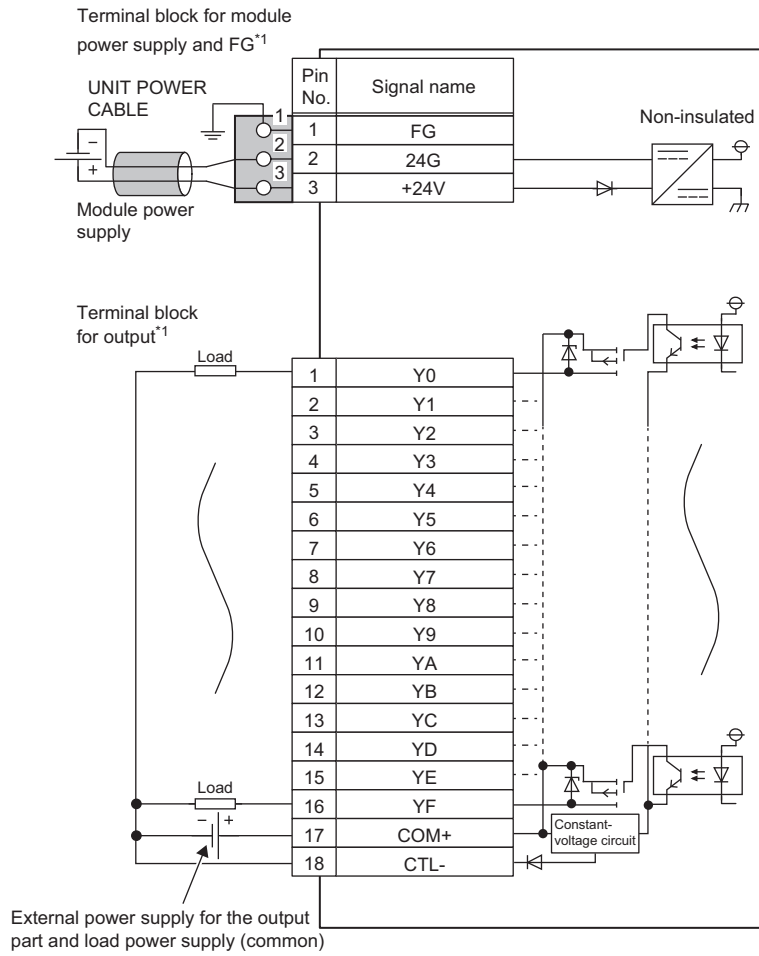

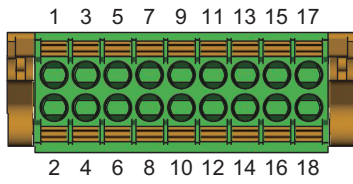

*1 Only one wire can be inserted into a wire insertion opening. Multiple wires cannot be connected to a terminal. Connecting two or more wires may cause a poor contact.

■ Terminal block for output



Terminal number	Signal name
1	Y0
2	Y1
3	Y2
4	Y3
5	Y4
6	Y5
7	Y6
8	Y7
9	Y8
10	Y9
11	YA
12	YB
13	YC
14	YD
15	YE
16	YF
17	COM+
18	CTL-

NZ2GN2S1-32TE transistor output module

Item		NZ2GN2S1-32TE
Station type		Intelligent device station
Network topology		Line topology, star topology, mixture of star topology and line topology, ring topology
Number of output points		32 points
Rated load voltage		12/24VDC (ripple rate: 5% or less) (Allowable voltage range: 10.2 to 28.8VDC)
Max. load current		0.5A/point, 5A/common
Maximum inrush current		Current is limited by the overload protection function.
Leakage current at OFF		0.1mA or less
Max. voltage drop at ON		0.5VDC (TYP.) 0.5A, 0.8VDC (MAX.) 0.5A
Output response time	OFF → ON	0.5ms or less
	ON → OFF	1.0ms or less (resistive load)
Surge suppressor		Zener diode
External power supply for output part	Voltage	12/24VDC (ripple rate: 5% or less) (Allowable voltage range: 10.2 to 28.8VDC)
	Current	80mA or less (TYP. 24VDC per common) External load current is not included.
Withstand voltage		510VAC for 1 minute between all DC external terminals and ground
Insulation resistance		10MΩ or higher between all DC external terminals and ground (500VDC insulation resistance tester)
Noise immunity		Noise voltage 500Vp-p, noise width 1μs, noise frequency 25 to 60Hz (DC type noise simulator condition)
Protection degree		IP2X
Wiring method for common		32 points/common (Common terminal: terminal number 33) (1-wire, spring clamp terminal block type) Source type
Protection function	Overload protection function	Limited current when detecting overcurrent: 1.5A or more/point Activated to each point.
	Overheat protection function	Activated to each point.
External interface	Communication part	RJ45 connector
	Module power supply part	Terminal block for module power supply and FG (2-piece spring clamp terminal block)
	I/O part	2-piece spring clamp terminal block
Applicable wire size	For power supply	Stranded wire: 0.3 to 1.5mm ² (22 to 16 AWG), terminal slot size: 2.4mm × 1.5mm ^{*1}
	For I/O	Stranded wire: 0.3 to 1.5mm ² (22 to 16 AWG)
Applicable solderless terminal ^{*2}	Terminal block for module power supply and FG	 Page 124 Applicable solderless terminal
	Terminal block for output	 Page 134 Applicable solderless terminal
Cyclic transmission	RX/RX points	32 points
	RWr/RWw points	4 points ^{*3}
Module power supply	Voltage	24VDC (ripple rate: 5% or less) (Allowable voltage range: 20.4 to 28.8VDC)
	Current	120mA or less (24VDC, all points ON)
Weight		0.18kg

*1 Use bar solderless terminals for wiring.

*2 Only one wire can be inserted into a wire insertion opening. Multiple wires cannot be connected to a terminal. Connecting two or more wires may cause a poor contact.

*3 This value indicates the number of points set by default when the module is dragged and dropped to the network map in the CC IE Field Configuration window. According to the function used, set an appropriate number of points. ( Page 223 Output module (32-point module))

External wiring

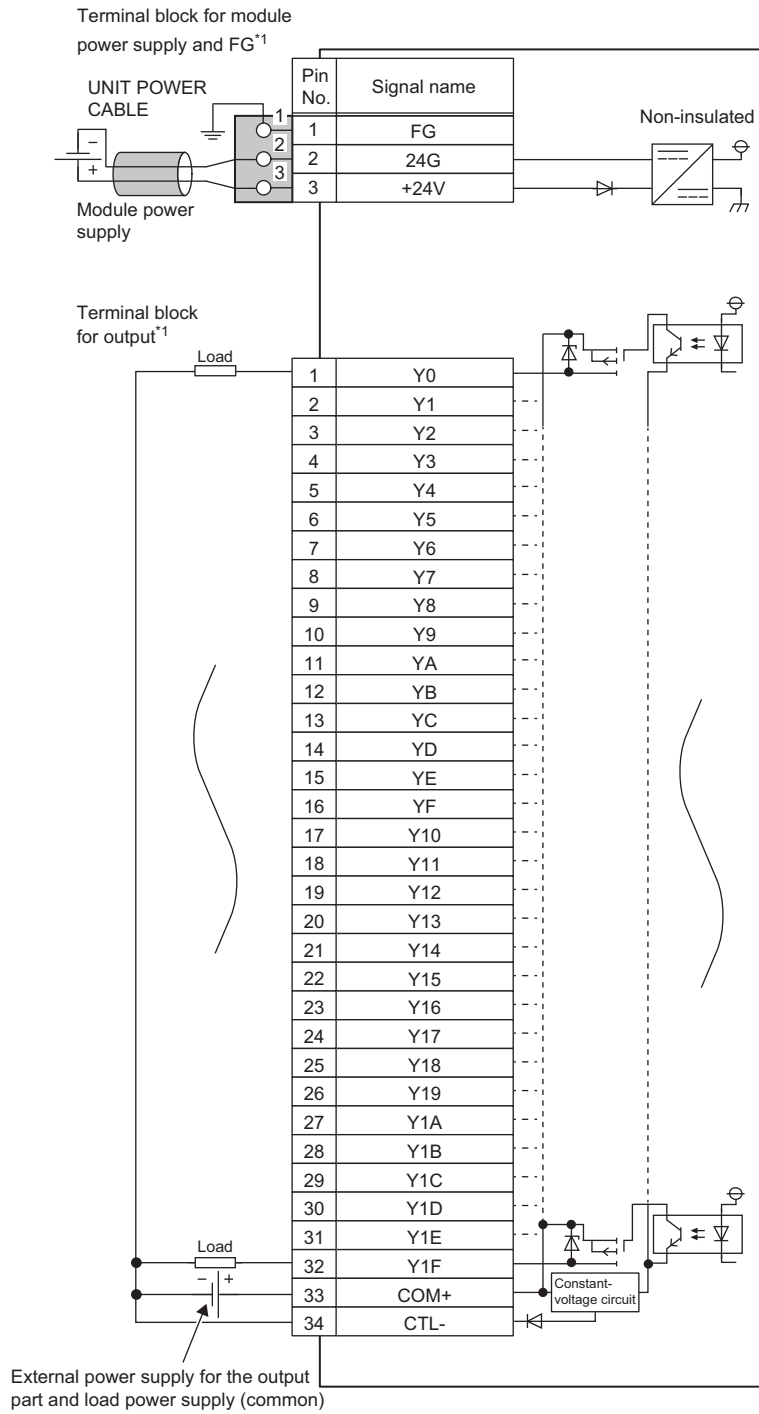

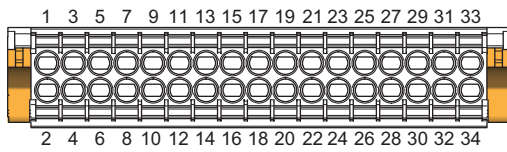

*1 Only one wire can be inserted into a wire insertion opening. Multiple wires cannot be connected to a terminal. Connecting two or more wires may cause a poor contact.

Terminal block for output



Terminal number	Signal name	Terminal number	Signal name
1	Y0	17	Y10
2	Y1	18	Y11
3	Y2	19	Y12
4	Y3	20	Y13
5	Y4	21	Y14
6	Y5	22	Y15
7	Y6	23	Y16
8	Y7	24	Y17
9	Y8	25	Y18
10	Y9	26	Y19
11	YA	27	Y1A
12	YB	28	Y1B
13	YC	29	Y1C
14	YD	30	Y1D
15	YE	31	Y1E
16	YF	32	Y1F
—		33	COM+
		34	CTL-

NZ2GN2B1-16TE transistor output module

Item		NZ2GN2B1-16TE
Station type		Remote device station
Network topology		Line topology, star topology, mixture of star topology and line topology, ring topology
Number of output points		16 points
Rated load voltage		12/24VDC (ripple rate: 5% or less) (Allowable voltage range: 10.2 to 28.8VDC)
Max. load current		0.5A/point, 4A/common
Maximum inrush current		Current is limited by the overload protection function.
Leakage current at OFF		0.1mA or less
Max. voltage drop at ON		0.5VDC (TYP.) 0.5A, 0.8VDC (MAX.) 0.5A
Output response time	OFF → ON	0.5ms or less
	ON → OFF	1.0ms or less (resistive load)
Surge suppressor		Zener diode
External power supply for output part	Voltage	12/24VDC (ripple rate: 5% or less) (Allowable voltage range: 10.2 to 28.8VDC)
	Current	80mA or less (TYP. 24VDC per common) External load current is not included.
Withstand voltage		510VAC for 1 minute between all DC external terminals and ground
Insulation resistance		10MΩ or higher between all DC external terminals and ground (500VDC insulation resistance tester)
Noise immunity		Noise voltage 500Vp-p, noise width 1μs, noise frequency 25 to 60Hz (DC type noise simulator condition)
Protection degree		IP2X
Wiring method for common		16 points/common (Common terminal: terminal number 17) (1-wire, screw terminal block type) Source type
Protection function	Overload protection function	Limited current when detecting overcurrent: 1.5A or more/point Activated to each point.
	Overheat protection function	Activated to each point.
External interface	Communication part	RJ45 connector
	Module power supply part	Terminal block for module power supply and FG (2-piece spring clamp terminal block)
	I/O part	18-point two-piece terminal block Tightening torque range for terminal screw (M3 × 5.2 screw): 0.43 to 0.57N·m Tightening torque range for terminal block mounting screw (M3.5 screw): 0.68 to 0.92N·m
Applicable wire size	For power supply	Stranded wire: 0.3 to 1.5mm ² (22 to 16 AWG), terminal slot size: 2.4mm × 1.5mm ^{*1}
	For I/O	Stranded wire: 0.3 to 2.0mm ² (22 to 14 AWG)
Applicable solderless terminal	Terminal block for module power supply and FG ^{*2}	 Page 124 Applicable solderless terminal
	Terminal block for output	 Page 138 Applicable solderless terminal
Multicast filter		Available
Cyclic transmission	RX/RV points	16 points
	RWr/RVw points	4 points ^{*3}
Module power supply	Voltage	24VDC (ripple rate: 5% or less) (Allowable voltage range: 20.4 to 28.8VDC)
	Current	110mA or less (24VDC, all points ON)
Weight		0.21kg

*1 Use bar solderless terminals for wiring.

*2 Only one wire can be inserted into a wire insertion opening for the terminal block for module power supply and FG. Multiple wires cannot be connected to a terminal. Connecting two or more wires may cause a poor contact.

*3 This value indicates the number of points set by default when the module is dragged and dropped to the network map in the CC IE Field Configuration window. According to the function used, set an appropriate number of points. ( Page 222 Output module (16-point module))

External wiring

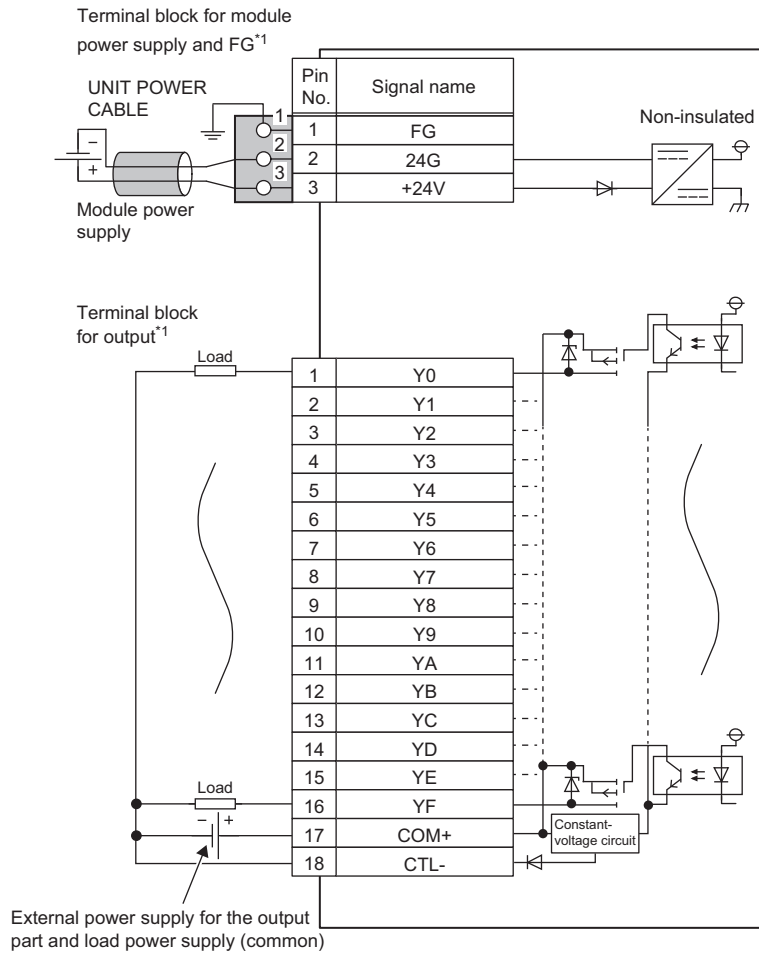

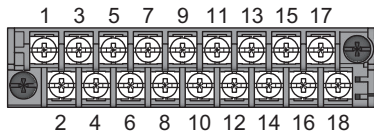

*1 Only one wire can be inserted into a wire insertion opening for the terminal block for module power supply and FG. Multiple wires cannot be connected to a terminal. Connecting two or more wires may cause a poor contact.

■ Terminal block for output



Terminal number	Signal name
1	Y0
2	Y1
3	Y2
4	Y3
5	Y4
6	Y5
7	Y6
8	Y7
9	Y8
10	Y9
11	YA
12	YB
13	YC
14	YD
15	YE
16	YF
17	COM+
18	CTL-

NZ2GN2B1-32TE transistor output module

Item		NZ2GN2B1-32TE
Station type		Intelligent device station
Network topology		Line topology, star topology, mixture of star topology and line topology, ring topology
Number of output points		32 points
Rated load voltage		12/24VDC (ripple rate: 5% or less) (Allowable voltage range: 10.2 to 28.8VDC)
Max. load current		0.5A/point, 5A/common
Maximum inrush current		Current is limited by the overload protection function.
Leakage current at OFF		0.1mA or less
Max. voltage drop at ON		0.5VDC (TYP.) 0.5A, 0.8VDC (MAX.) 0.5A
Output response time	OFF → ON	0.5ms or less
	ON → OFF	1.0ms or less (resistive load)
Surge suppressor		Zener diode
External power supply for output part	Voltage	12/24VDC (ripple rate: 5% or less) (Allowable voltage range: 10.2 to 28.8VDC)
	Current	80mA or less (TYP. 24VDC per common) External load current is not included.
Withstand voltage		510VAC for 1 minute between all DC external terminals and ground
Insulation resistance		10MΩ or higher between all DC external terminals and ground (500VDC insulation resistance tester)
Noise immunity		Noise voltage 500Vp-p, noise width 1μs, noise frequency 25 to 60Hz (DC type noise simulator condition)
Protection degree		IP2X
Wiring method for common		32 points/common (Common terminal: terminal number 33) (1-wire, screw terminal block type) Source type
Protection function	Overload protection function	Limited current when detecting overcurrent: 1.5A or more/point Activated to each point.
	Overheat protection function	Activated to each point.
External interface	Communication part	RJ45 connector
	Module power supply part	Terminal block for module power supply and FG (2-piece spring clamp terminal block)
	I/O part	34-point two-piece terminal block Tightening torque range for terminal screw (M3 × 5.2 screw): 0.43 to 0.57N·m Tightening torque range for terminal block mounting screw (M3.5 screw): 0.68 to 0.92N·m
Applicable wire size	For power supply	Stranded wire: 0.3 to 1.5mm ² (22 to 16 AWG), terminal slot size: 2.4mm × 1.5mm ^{*1}
	For I/O	Stranded wire: 0.3 to 2.0mm ² (22 to 14 AWG)
Applicable solderless terminal	Terminal block for module power supply and FG ^{*2}	 Page 124 Applicable solderless terminal
	Terminal block for output	 Page 138 Applicable solderless terminal
Cyclic transmission	RX/RV points	32 points
	RWr/RVw points	4 points ^{*3}
Module power supply	Voltage	24VDC (ripple rate: 5% or less) (Allowable voltage range: 20.4 to 28.8VDC)
	Current	120mA or less (24VDC, all points ON)
Weight		0.29kg

*1 Use bar solderless terminals for wiring.

*2 Only one wire can be inserted into a wire insertion opening for the terminal block for module power supply and FG. Multiple wires cannot be connected to a terminal. Connecting two or more wires may cause a poor contact.

*3 This value indicates the number of points set by default when the module is dragged and dropped to the network map in the CC IE Field Configuration window. According to the function used, set an appropriate number of points. ( Page 223 Output module (32-point module))

External wiring

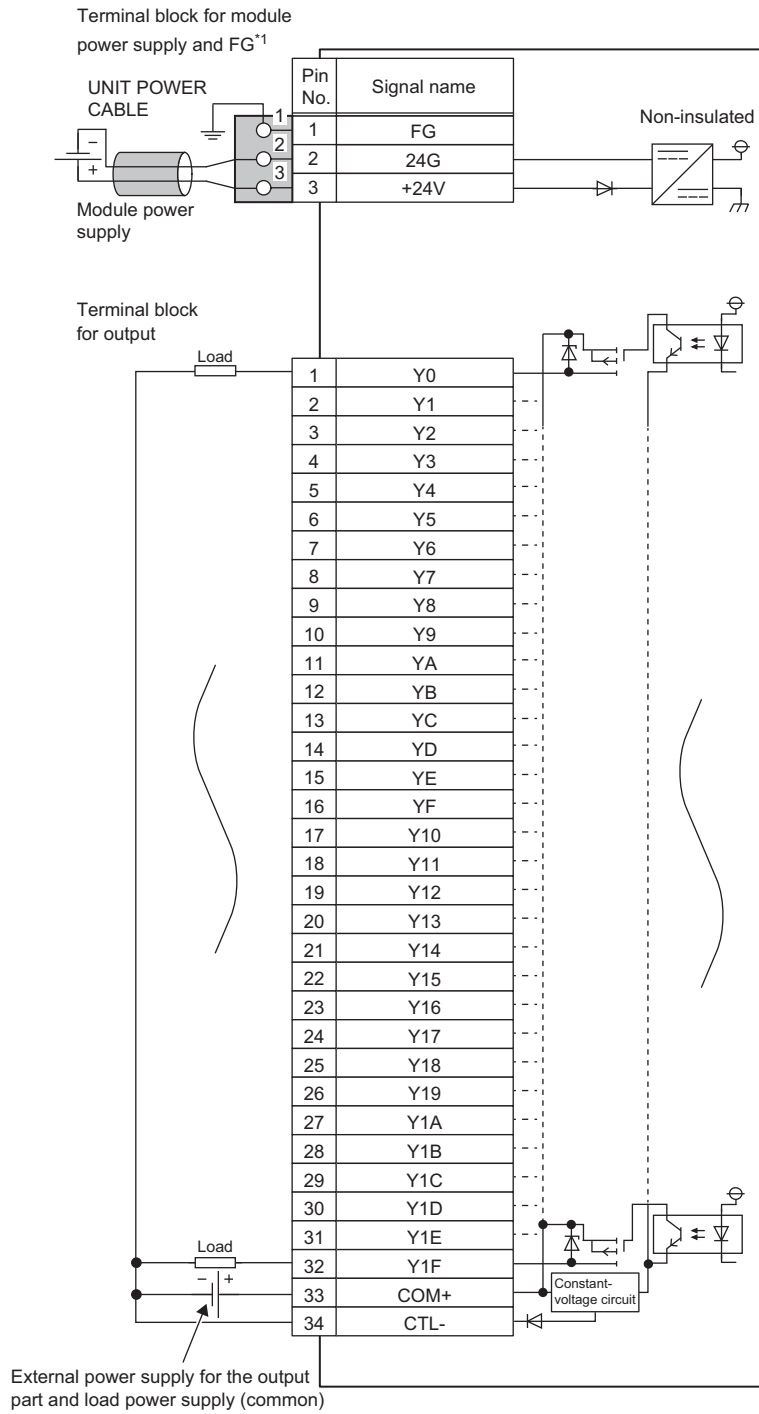

*1 Only one wire can be inserted into a wire insertion opening for the terminal block for module power supply and FG. Multiple wires cannot be connected to a terminal. Connecting two or more wires may cause a poor contact.

Terminal block for output

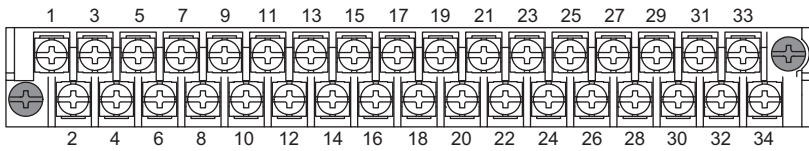

Terminal number	Signal name	Terminal number	Signal name
1	Y0	17	Y10
2	Y1	18	Y11
3	Y2	19	Y12
4	Y3	20	Y13
5	Y4	21	Y14
6	Y5	22	Y15
7	Y6	23	Y16
8	Y7	24	Y17
9	Y8	25	Y18
10	Y9	26	Y19
11	YA	27	Y1A
12	YB	28	Y1B
13	YC	29	Y1C
14	YD	30	Y1D
15	YE	31	Y1E
16	YF	32	Y1F
—		33	COM+
		34	CTL-

NZ2GN12A2-16TE transistor output module

Item		NZ2GN12A2-16TE
Station type		Remote device station
Network topology		Line topology, star topology, mixture of star topology and line topology, ring topology
Number of output points		16 points
Rated load voltage		12/24VDC (ripple rate: 5% or less) (Allowable voltage range: 10.2 to 28.8VDC)
Max. load current		4A/point (Y0 to Y3) ^{*1} , 2A/point (Y4 to YF), 12A/common
Maximum inrush current		Current is limited by the overload protection function.
Leakage current at OFF		0.1mA or less
Max. voltage drop at ON		0.3VDC (TYP.) 2A, 0.6VDC (MAX.) 2A, 0.6VDC (TYP.) 4A, 1.2VDC (MAX.) 4A
Output response time	OFF → ON	0.5ms or less
	ON → OFF	1.0ms or less (resistive load)
Surge suppressor		Zener diode
External power supply for output part ^{*3}	Voltage	12/24VDC (ripple rate: 5% or less) (Allowable voltage range: 10.2 to 28.8VDC)
	Current	45mA or less (TYP. 24VDC per common) External load current is not included.
Withstand voltage		720VDC for 1 minute between all DC external terminals and ground
Insulation resistance		10MΩ or higher between all DC external terminals and ground (500VDC insulation resistance tester)
Noise immunity		Noise voltage 500Vp-p, noise width 1μs, noise frequency 25 to 60Hz (DC type noise simulator condition)
Protection degree		IP67
Wiring method for common		16 points/common (2-wire, waterproof connector type) Source type
Protection function	Overload protection function	Limited current when detecting overcurrent: 5.2A or more/point Activated to each point.
	Overheat protection function	Activated to each point.
External interface	Communication part	M12 waterproof connector, 8 pins, female, X-code
	Module power supply part	M12 waterproof connector, 5 pins, male, female, L-code
	I/O part	M12 waterproof connector, 5 pins, female, A-code
Applicable waterproof connector	For communications	☞ Page 147 List of Recommended Cables/Connectors for the I/O Module (Waterproof Module)
	For power supply	
	For I/O	
	Y-branch connector for I/O	
Multicast filter		Available
Cyclic transmission	RX/Ry points	16 points
	RWw/RWw points	4 points ^{*2}
Module power supply ^{*3}	Voltage	24VDC (ripple rate: 5% or less) (Allowable voltage range: 20.4 to 28.8VDC)
	Current	110mA or less (24VDC, all points ON)
Weight		0.42kg

*1 Make sure that the total amount of output current that flows through one connector is 4A or less.

*2 This value indicates the number of points set by default when the module is dragged and dropped to the network map in the CC IE Field Configuration window. According to the function used, set an appropriate number of points. (☞ Page 222 Output module (16-point module))

*3 For a power supply to be connected to the waterproof I/O module (such as the module-and-sensor power supply or the load power supply and external power supply for output part), use the power supply that meets the following condition.
SELV (Safety Extra Low Voltage): Product with reinforced insulation from the hazardous potential part (60V or higher)

Derating chart

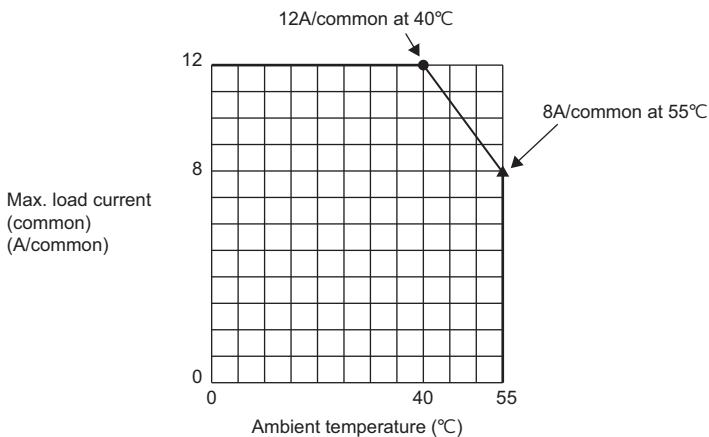

- : Module-and-sensor power supply current, 8A
 - ▲: Module-and-sensor power supply current, 6A
- The module-and-sensor power supply current is 6A when the ambient temperature is 40°C or higher.

External wiring

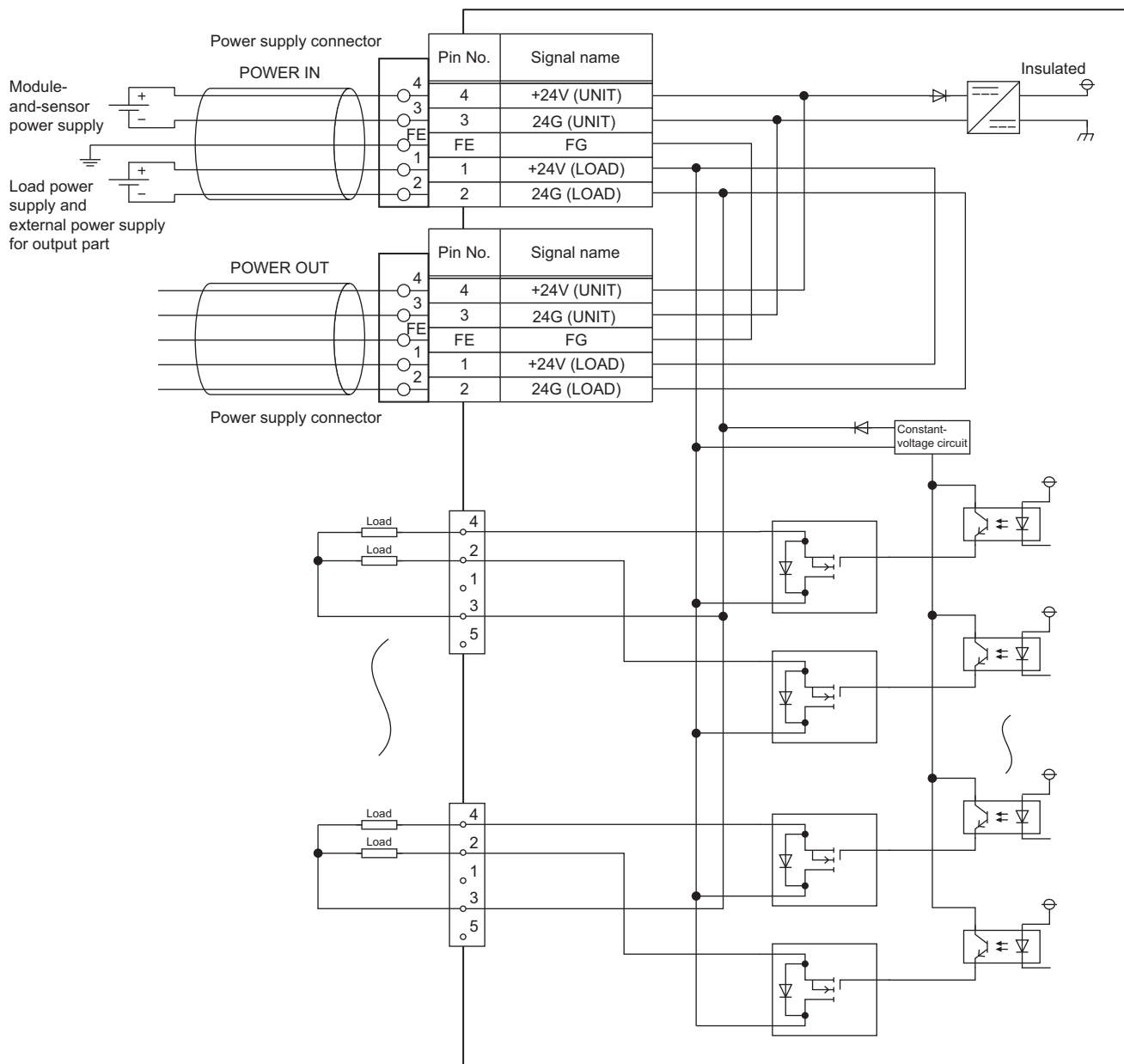

■ Power supply connectors

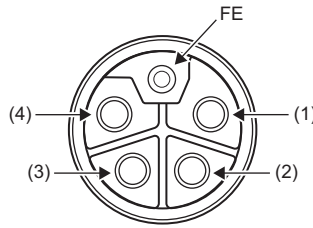
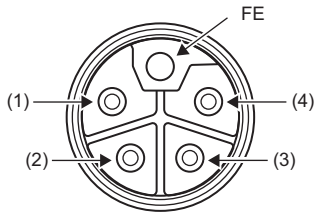

Pin number		Signal name	Pin number		Signal name
M12 connector, male (IN)	(1)	+24V (LOAD)	M12 connector, female (OUT)	(1)	+24V (LOAD)
	(2)	24G (LOAD)		(2)	24G (LOAD)
	(3)	24G (UNIT)		(3)	24G (UNIT)
	(4)	+24V (UNIT)		(4)	+24V (UNIT)
	FE	FG		FE	FG

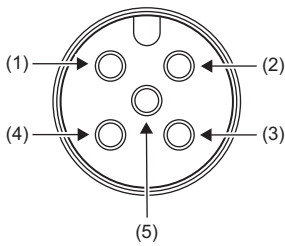

■ Connector for output



Pin number		Signal name	Pin number		Signal name
Y0 Y1	(1)	Empty	Y8 Y9	(1)	Empty
	(2)	Y1		(2)	Y9
	(3)	24V (LOAD)		(3)	24V (LOAD)
	(4)	Y0		(4)	Y8
	(5)	Empty		(5)	Empty
Y2 Y3	(1)	Empty	YA YB	(1)	Empty
	(2)	Y3		(2)	YB
	(3)	24V (LOAD)		(3)	24V (LOAD)
	(4)	Y2		(4)	YA
	(5)	Empty		(5)	Empty
Y4 Y5	(1)	Empty	YC YD	(1)	Empty
	(2)	Y5		(2)	YD
	(3)	24V (LOAD)		(3)	24V (LOAD)
	(4)	Y4		(4)	YC
	(5)	Empty		(5)	Empty
Y6 Y7	(1)	Empty	YE YF	(1)	Empty
	(2)	Y7		(2)	YF
	(3)	24V (LOAD)		(3)	24V (LOAD)
	(4)	Y6		(4)	YE
	(5)	Empty		(5)	Empty

I/O combined module

NZ2GN2S1-32DT DC input/transistor output module

Item		NZ2GN2S1-32DT
■Input specifications		
Number of input points		16 points
Rated input voltage		24VDC (ripple rate: 5% or less) (Allowable voltage range: 20.4 to 28.8VDC)
Rated input current		6.0mA TYP. (for 24VDC)
Maximum number of simultaneous input points		100%
ON voltage/ON current		11VDC or more/4mA or more
OFF voltage/OFF current		5VDC or less/1.5mA or less
Input resistance		3.3kΩ
Input response time	OFF → ON	0ms ^{*1} /0.2ms/1ms/1.5ms/5ms/10ms/20ms/70ms
	ON → OFF	(Factory default: 1ms)
Wiring method for common		16 points/common (Common terminal: terminal number 33) (1-wire, spring clamp terminal block type) Positive common type
■Output specifications		
Number of output points		16 points
Rated load voltage		24VDC (ripple rate: 5% or less) (Allowable voltage range: 20.4 to 28.8VDC)
Max. load current		0.5A/point, 4A/common
Maximum inrush current		Current is limited by the overload protection function.
Leakage current at OFF		0.1mA or less
Max. voltage drop at ON		0.3VDC (TYP.) 0.5A, 0.6VDC (MAX.) 0.5A
Output response time	OFF → ON	0.1ms or less
	ON → OFF	0.8ms or less (resistive load)
Surge suppressor		Zener diode
External power supply for output part	Voltage	24VDC (ripple rate: 5% or less) (Allowable voltage range: 20.4 to 28.8VDC)
	Current	25mA or less (TYP. 24VDC per common) External load current is not included.
Protection function	Overload protection function	Limited current when detecting overcurrent: 1.5 to 3.5A/point Activated to each point.
	Overheat protection function	Activated to each point.
Wiring method for common		16 points/common (Common terminal: terminal number 34) (1-wire, spring clamp terminal block type) Sink type
■Common specifications		
Station type		Intelligent device station
Network topology		Line topology, star topology, mixture of star topology and line topology, ring topology
Withstand voltage		510VAC for 1 minute between all DC external terminals and ground
Insulation resistance		10MΩ or higher between all DC external terminals and ground (500VDC insulation resistance tester)
Noise immunity ^{*2}		Noise voltage 500Vp-p, noise width 1μs, noise frequency 25 to 60Hz (DC type noise simulator condition)
Protection degree		IP2X
External interface	Communication part	RJ45 connector
	Module power supply part	Terminal block for module power supply and FG (2-piece spring clamp terminal block)
	I/O part	2-piece spring clamp terminal block
Applicable wire size	For power supply	Stranded wire: 0.3 to 1.5mm ² (22 to 16 AWG), terminal slot size: 2.4mm × 1.5mm ^{*3}
	For I/O	Stranded wire: 0.3 to 1.5mm ² (22 to 16 AWG)
Applicable solderless terminal ^{*4}	Terminal block for module power supply and FG	 Page 124 Applicable solderless terminal
	I/O terminal block	 Page 134 Applicable solderless terminal
Cyclic transmission	RX/Ry points	32 points
	RW/RWw points	4 points ^{*5}

Item		NZ2GN2S1-32DT
Module power supply	Voltage	24VDC (ripple rate: 5% or less) (Allowable voltage range: 20.4 to 28.8VDC)
	Current	110mA or less (24VDC, all points ON)
Weight		0.20kg

- *1 If the input response time is set to "0ms", the actual input response time is 80 μ s at OFF \rightarrow ON, and 160 μ s at ON \rightarrow OFF.
- *2 It is the noise immunity of when the input response time setting value is other than "0ms". Note that the module is easily affected by noise if "0ms" is set.
- *3 Use bar solderless terminals for wiring.
- *4 Only one wire can be inserted into a wire insertion opening. Multiple wires cannot be connected to a terminal. Connecting two or more wires may cause a poor contact.
- *5 This value indicates the number of points set by default when the module is dragged and dropped to the network map in the CC IE Field Configuration window. According to the function used, set an appropriate number of points. ( Page 225 I/O combined module (32-point module))

External wiring

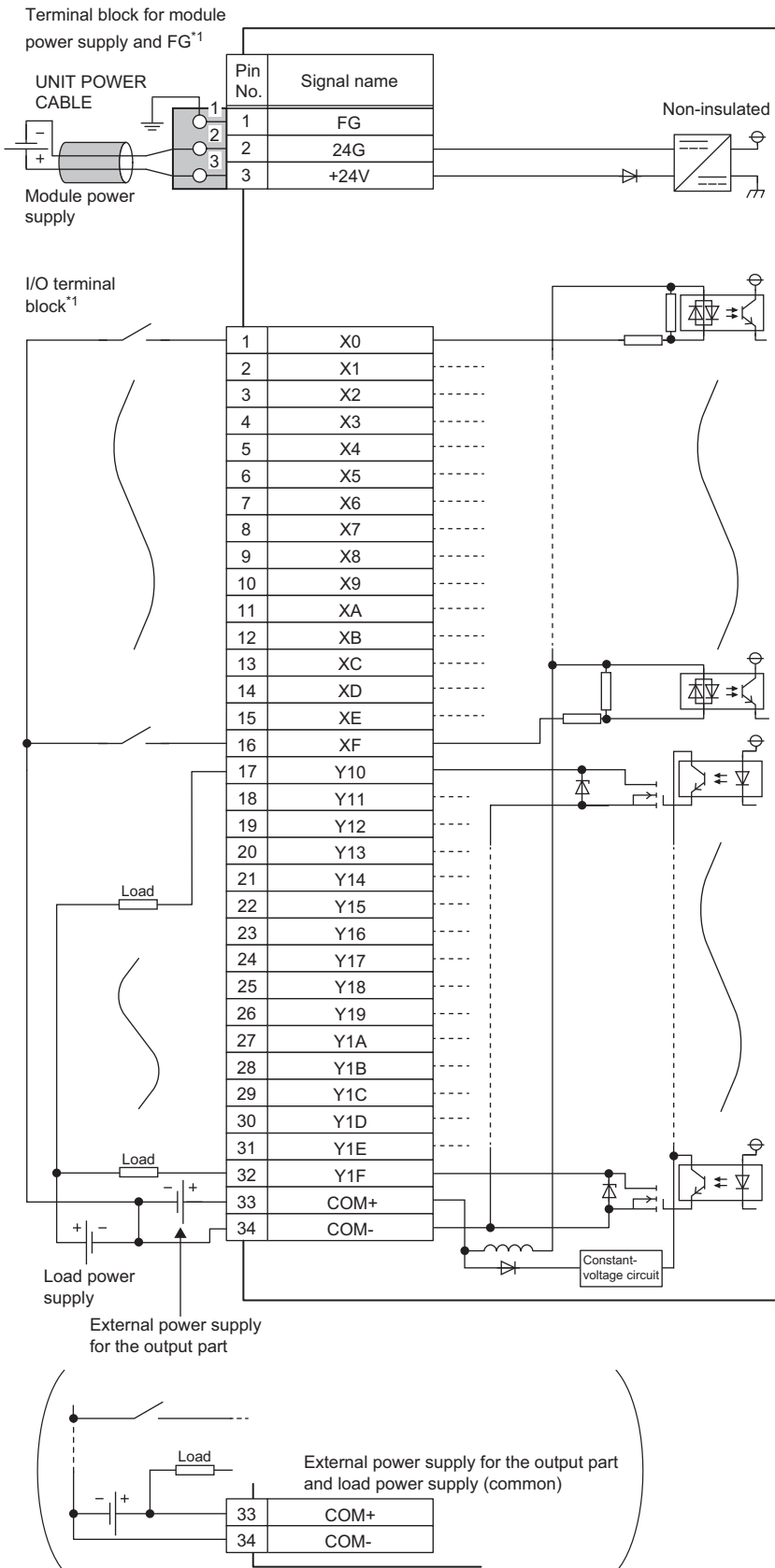

*1 Only one wire can be inserted into a wire insertion opening. Multiple wires cannot be connected to a terminal. Connecting two or more wires may cause a poor contact.

■ I/O terminal block

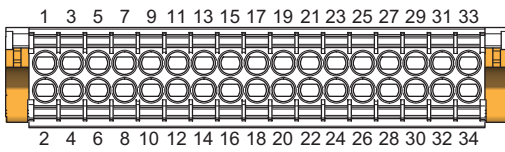

Terminal number	Signal name	Terminal number	Signal name
1	X0	17	Y10
2	X1	18	Y11
3	X2	19	Y12
4	X3	20	Y13
5	X4	21	Y14
6	X5	22	Y15
7	X6	23	Y16
8	X7	24	Y17
9	X8	25	Y18
10	X9	26	Y19
11	XA	27	Y1A
12	XB	28	Y1B
13	XC	29	Y1C
14	XD	30	Y1D
15	XE	31	Y1E
16	XF	32	Y1F
—		33	COM+
		34	COM-

NZ2GN2B1-32DT DC input/transistor output module

Item		NZ2GN2B1-32DT
■Input specifications		
Number of input points		16 points
Rated input voltage		24VDC (ripple rate: 5% or less) (Allowable voltage range: 20.4 to 28.8VDC)
Rated input current		6.0mA TYP. (for 24VDC)
Maximum number of simultaneous input points		100%
ON voltage/ON current		11VDC or more/4mA or more
OFF voltage/OFF current		5VDC or less/1.5mA or less
Input resistance		3.3kΩ
Input response time	OFF → ON	0ms ^{*1} /0.2ms/1ms/1.5ms/5ms/10ms/20ms/70ms
	ON → OFF	(Factory default: 1ms)
Wiring method for common		16 points/common (Common terminal: terminal number 33) (1-wire, screw terminal block type) Positive common type
■Output specifications		
Number of output points		16 points
Rated load voltage		24VDC (ripple rate: 5% or less) (Allowable voltage range: 20.4 to 28.8VDC)
Max. load current		0.5A/point, 4A/common
Maximum inrush current		Current is limited by the overload protection function.
Leakage current at OFF		0.1mA or less
Max. voltage drop at ON		0.3VDC (TYP.) 0.5A, 0.6VDC (MAX.) 0.5A
Output response time	OFF → ON	0.1ms or less
	ON → OFF	0.8ms or less (resistive load)
Surge suppressor		Zener diode
External power supply for output part	Voltage	24VDC (ripple rate: 5% or less) (Allowable voltage range: 20.4 to 28.8VDC)
	Current	25mA or less (TYP. 24VDC per common) External load current is not included.
Protection function	Overload protection function	Limited current when detecting overcurrent: 1.5 to 3.5A/point Activated to each point.
	Overheat protection function	Activated to each point.
Wiring method for common		16 points/common (Common terminal: terminal number 34) (1-wire, screw terminal block type) Sink type
■Common specifications		
Station type		Intelligent device station
Network topology		Line topology, star topology, mixture of star topology and line topology, ring topology
Withstand voltage		510VAC for 1 minute between all DC external terminals and ground
Insulation resistance		10MΩ or higher between all DC external terminals and ground (500VDC insulation resistance tester)
Noise immunity ^{*2}		Noise voltage 500Vp-p, noise width 1μs, noise frequency 25 to 60Hz (DC type noise simulator condition)
Protection degree		IP2X
External interface	Communication part	RJ45 connector
	Module power supply part	Terminal block for module power supply and FG (2-piece spring clamp terminal block)
	I/O part	34-point two-piece terminal block Tightening torque range for terminal screw (M3 × 5.2 screw): 0.43 to 0.57N·m Tightening torque range for terminal block mounting screw (M3.5 screw): 0.68 to 0.92N·m
Applicable wire size	For power supply	Stranded wire: 0.3 to 1.5mm ² (22 to 16 AWG), terminal slot size: 2.4mm × 1.5mm ^{*3}
	For I/O	Stranded wire: 0.3 to 2.0mm ² (22 to 14 AWG)
Applicable solderless terminal	Terminal block for module power supply and FG ^{*4}	☞ Page 124 Applicable solderless terminal
	I/O terminal block	☞ Page 138 Applicable solderless terminal
Cyclic transmission	RX/RY points	32 points
	RWr/RWw points	4 points ^{*5}
Module power supply	Voltage	24VDC (ripple rate: 5% or less) (Allowable voltage range: 20.4 to 28.8VDC)
	Current	110mA or less (24VDC, all points ON)
Weight		0.31kg

- *1 If the input response time is set to "0ms", the actual input response time is 80 μ s at OFF \rightarrow ON, and 160 μ s at ON \rightarrow OFF.
- *2 It is the noise immunity of when the input response time setting value is other than "0ms". Note that the module is easily affected by noise if "0ms" is set.
- *3 Use bar solderless terminals for wiring.
- *4 Only one wire can be inserted into a wire insertion opening for the terminal block for module power supply and FG. Multiple wires cannot be connected to a terminal. Connecting two or more wires may cause a poor contact.
- *5 This value indicates the number of points set by default when the module is dragged and dropped to the network map in the CC IE Field Configuration window. According to the function used, set an appropriate number of points. ( Page 225 I/O combined module (32-point module))

External wiring

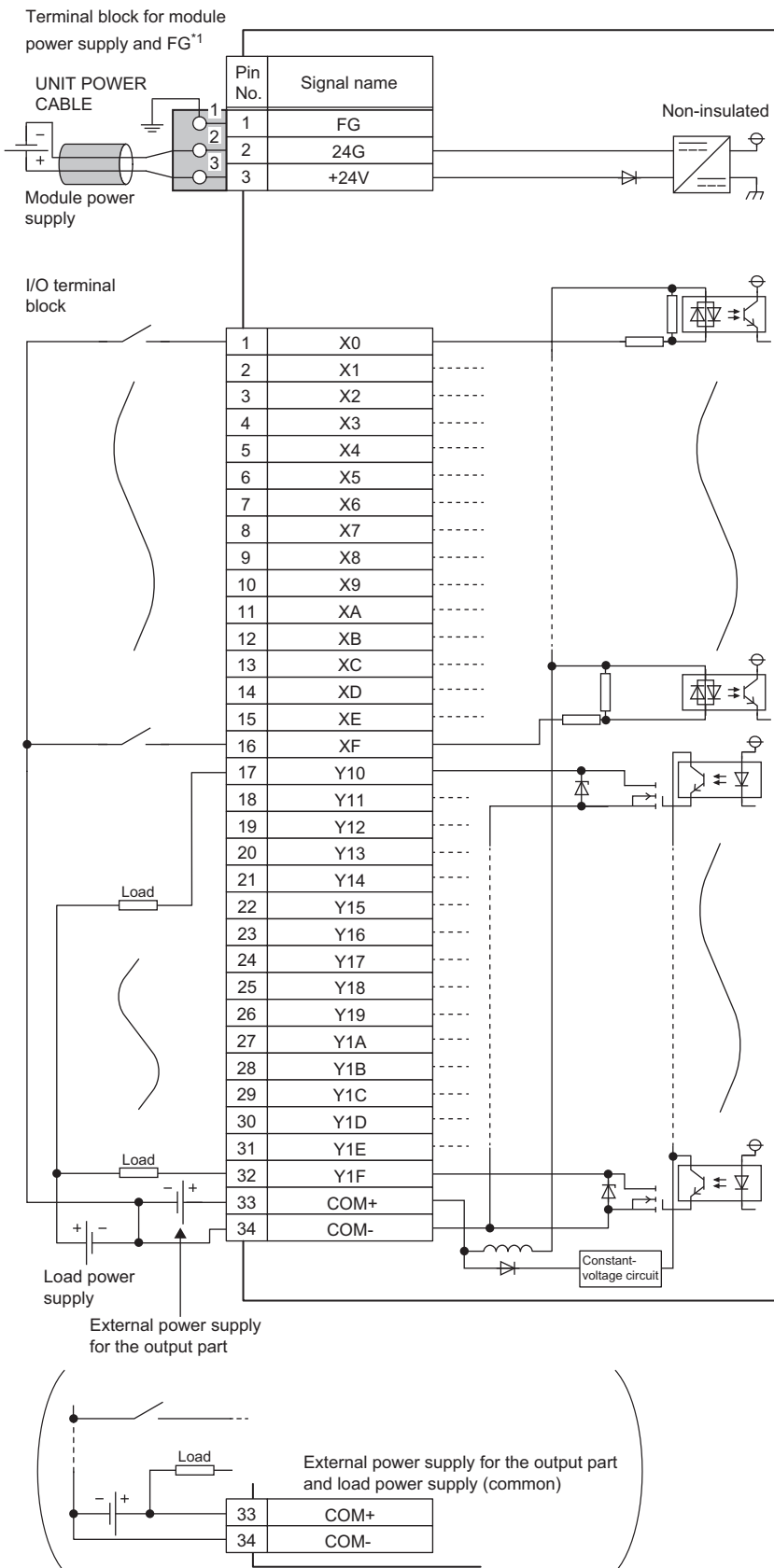

*1 Only one wire can be inserted into a wire insertion opening for the terminal block for module power supply and FG. Multiple wires cannot be connected to a terminal. Connecting two or more wires may cause a poor contact.

■ I/O terminal block

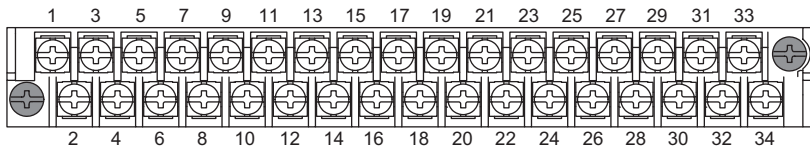

Terminal number	Signal name	Terminal number	Signal name
1	X0	17	Y10
2	X1	18	Y11
3	X2	19	Y12
4	X3	20	Y13
5	X4	21	Y14
6	X5	22	Y15
7	X6	23	Y16
8	X7	24	Y17
9	X8	25	Y18
10	X9	26	Y19
11	XA	27	Y1A
12	XB	28	Y1B
13	XC	29	Y1C
14	XD	30	Y1D
15	XE	31	Y1E
16	XF	32	Y1F
—		33	COM+
		34	COM-

NZ2GNCE3-32DT DC input/transistor output module

Item		NZ2GNCE3-32DT
■Input specifications		
Number of input points		16 points
Rated input voltage		24VDC (ripple rate: 5% or less) (Allowable voltage range: 20.4 to 28.8VDC)
Rated input current		6.6mA TYP. (for 24VDC)
Maximum number of simultaneous input points		100%
ON voltage/ON current		11VDC or more/4mA or more
OFF voltage/OFF current		5VDC or less/1.5mA or less
Input resistance		3.3kΩ
Input response time	OFF → ON	0ms ^{*1} /0.2ms/1ms/1.5ms/5ms/10ms/20ms/70ms
	ON → OFF	(Factory default: 1ms)
Wiring method for common		16 points/common (3-wire, sensor connector (e-CON) type) Positive common type
■Output specifications		
Number of output points		16 points
Rated load voltage		24VDC (ripple rate: 5% or less) (Allowable voltage range: 20.4 to 28.8VDC)
Max. load current		0.5A/point, 4A/common
Maximum inrush current		Current is limited by the overload protection function.
Leakage current at OFF		0.1mA or less
Max. voltage drop at ON		0.3VDC (TYP.) 0.5A, 0.6VDC (MAX.) 0.5A
Output response time	OFF → ON	0.1ms or less
	ON → OFF	0.8ms or less (resistive load)
Surge suppressor		Zener diode
External power supply for output part	Voltage	24VDC (ripple rate: 5% or less) (Allowable voltage range: 20.4 to 28.8VDC)
	Current	25mA or less (TYP. 24VDC per common) External load current is not included.
Protection function	Overload protection function	Limited current when detecting overcurrent: 1.5 to 3.5A/point Activated to each point.
	Overheat protection function	Activated to each point.
Wiring method for common		16 points/common (3-wire, sensor connector (e-CON) type) Sink type
■Common specifications		
Station type		Intelligent device station
Network topology		Line topology, star topology, mixture of star topology and line topology, ring topology
Withstand voltage		510VAC for 1 minute between all DC external terminals and ground
Insulation resistance		10MΩ or higher between all DC external terminals and ground (500VDC insulation resistance tester)
Noise immunity ^{*2}		Noise voltage 500Vp-p, noise width 1μs, noise frequency 25 to 60Hz (DC type noise simulator condition)
Protection degree		IP2X
External interface	Communication part	RJ45 connector
	Module power supply part	One-touch connector for power supply and FG (5 pins, crimping type)
	I/O part	Sensor connector (e-CON) (4 pins, crimping type)
Applicable wire size	For power supply	0.66 to 0.98mm ² (18 AWG) [Finishing outer diameter: φ2.2 to 3.0mm (A6CON-PW5P), φ2.0 to 2.3mm (A6CON-PW5P-SOD)] Strand diameter: 0.16mm or longer Insulating coating material: PVC (heat resistant vinyl)
	For I/O	Sensor connector (e-CON) The size depends on the connector plug used (sold separately). (☞ Page 145 Wiring of sensor connector (e-CON))
Cyclic transmission	RX/RY points	32 points
	RWr/RWw points	4 points ^{*3}
Module power supply	Voltage	24VDC (ripple rate: 5% or less) (Allowable voltage range: 20.4 to 28.8VDC)
	Current	110mA or less (24VDC, all points ON)
Weight		0.25kg

- *1 If the input response time is set to "0ms", the actual input response time is 80μs at OFF → ON, and 160μs at ON → OFF.
- *2 It is the noise immunity of when the input response time setting value is other than "0ms". Note that the module is easily affected by noise if "0ms" is set.
- *3 This value indicates the number of points set by default when the module is dragged and dropped to the network map in the CC IE Field Configuration window. According to the function used, set an appropriate number of points. (Page 225 I/O combined module (32-point module))

External wiring

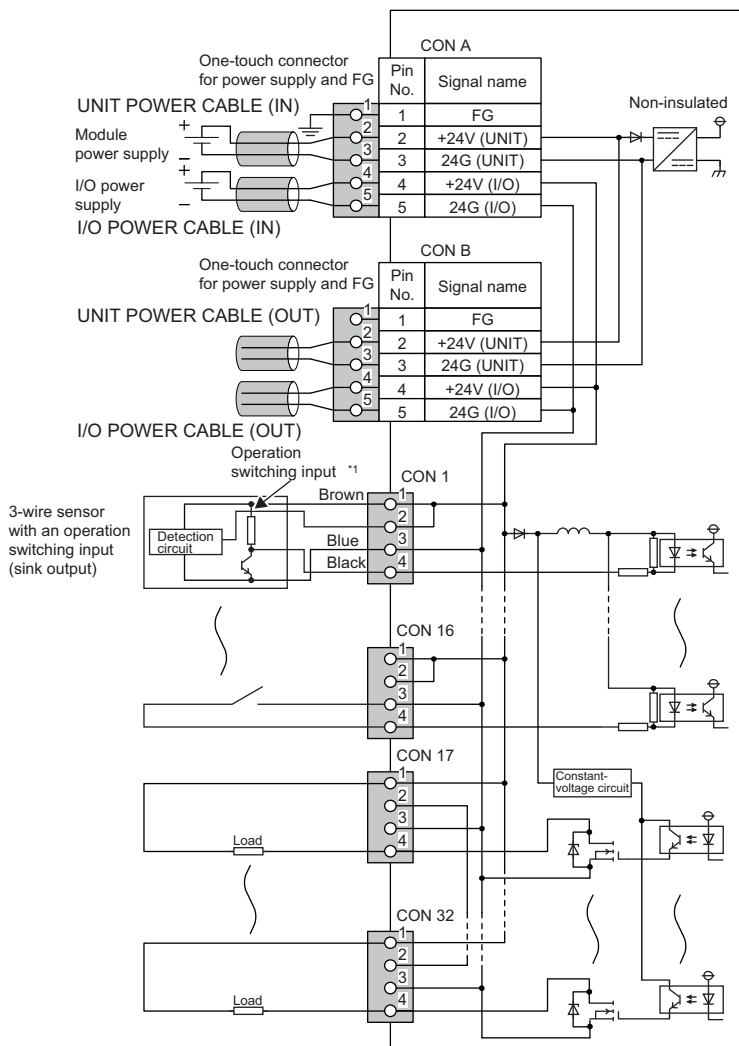

• When an online connector is connected

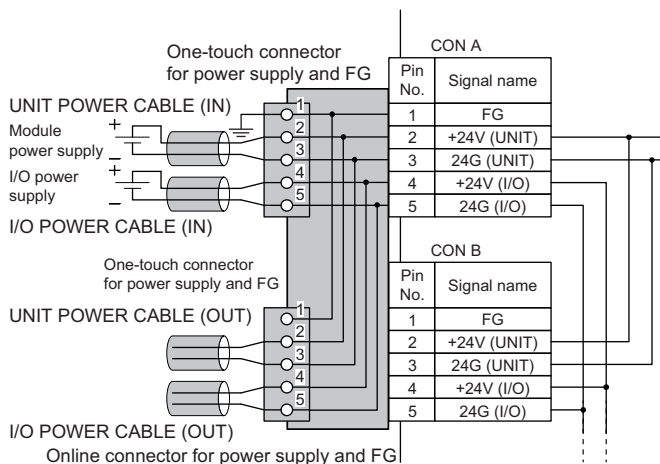

*1 The colors of leads correspond to IEC 60947-5-2.

■ Connector for module power supply and FG

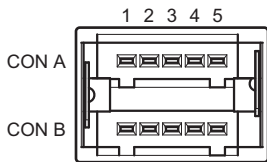

Terminal number ^{*1}	Signal name	
CON A	1	FG
CON B	2	+24V (UNIT)
	3	24G (UNIT)
	4	+24V (I/O)
	5	24G (I/O)

*1 A non-wired connector must be connected to the empty slot of the connector for module power supply and FG.

■ Connector for I/O

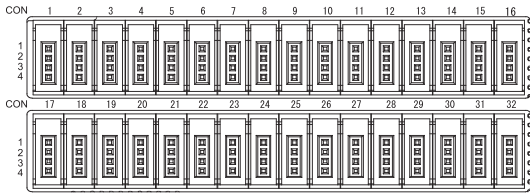

Terminal number	Signal name	Terminal number	Signal name	Terminal number	Signal name	Terminal number	Signal name				
CON1 (X0)	1	+24V	CON9 (X8)	1	+24V	CON17 (Y10)	1	+24V	CON25 (Y18)	1	+24V
	2	+V		2	+V		2	NC*1		2	NC*1
	3	24G		3	24G		3	24G		3	24G
	4	X0		4	X8		4	Y10		4	Y18
CON2 (X1)	1	+24V	CON10 (X9)	1	+24V	CON18 (Y11)	1	+24V	CON26 (Y19)	1	+24V
	2	+V		2	+V		2	NC*1		2	NC*1
	3	24G		3	24G		3	24G		3	24G
	4	X1		4	X9		4	Y11		4	Y19
CON3 (X2)	1	+24V	CON11 (XA)	1	+24V	CON19 (Y12)	1	+24V	CON27 (Y1A)	1	+24V
	2	+V		2	+V		2	NC*1		2	NC*1
	3	24G		3	24G		3	24G		3	24G
	4	X2		4	XA		4	Y12		4	Y1A
CON4 (X3)	1	+24V	CON12 (XB)	1	+24V	CON20 (Y13)	1	+24V	CON28 (Y1B)	1	+24V
	2	+V		2	+V		2	NC*1		2	NC*1
	3	24G		3	24G		3	24G		3	24G
	4	X3		4	XB		4	Y13		4	Y1B
CON5 (X4)	1	+24V	CON13 (XC)	1	+24V	CON21 (Y14)	1	+24V	CON29 (Y1C)	1	+24V
	2	+V		2	+V		2	NC*1		2	NC*1
	3	24G		3	24G		3	24G		3	24G
	4	X4		4	XC		4	Y14		4	Y1C
CON6 (X5)	1	+24V	CON14 (XD)	1	+24V	CON22 (Y15)	1	+24V	CON30 (Y1D)	1	+24V
	2	+V		2	+V		2	NC*1		2	NC*1
	3	24G		3	24G		3	24G		3	24G
	4	X5		4	XD		4	Y15		4	Y1D
CON7 (X6)	1	+24V	CON15 (XE)	1	+24V	CON23 (Y16)	1	+24V	CON31 (Y1E)	1	+24V
	2	+V		2	+V		2	NC*1		2	NC*1
	3	24G		3	24G		3	24G		3	24G
	4	X6		4	XE		4	Y16		4	Y1E
CON8 (X7)	1	+24V	CON16 (XF)	1	+24V	CON24 (Y17)	1	+24V	CON32 (Y1F)	1	+24V
	2	+V		2	+V		2	NC*1		2	NC*1
	3	24G		3	24G		3	24G		3	24G
	4	X7		4	XF		4	Y17		4	Y1F

*1 All the pin 2 of CON17 to CON32 cannot be used because they are internally connected.

NZ2GN12A42-16DT DC input/transistor output module

Item		NZ2GN12A42-16DT
■Input specifications		
Number of input points		8 points
Rated input voltage		24VDC (ripple rate: 5% or less) (Allowable voltage range: 20.4 to 28.8VDC)
Rated input current		7.3mA TYP. (for 24VDC)
Maximum number of simultaneous input points		100%
ON voltage/ON current		11VDC or more/4mA or more
OFF voltage/OFF current		5VDC or less/1.5mA or less
Input resistance		3.0kΩ
Input response time	OFF → ON	0ms ^{*1} /0.2ms/1ms/1.5ms/5ms/10ms/20ms/70ms
	ON → OFF	(Factory default: 10ms)
Wiring method for common		8 points/common (2- to 4-wire, waterproof connector type) Positive common type
Current supplied to external devices		0.4A/terminal
■Output specifications		
Number of output points		8 points
Rated load voltage		12/24VDC (ripple rate: 5% or less) (Allowable voltage range: 10.2 to 28.8VDC)
Max. load current		4A/point (Y8 to YB) ^{*2} , 2A/point (YC to YF), 12A/common
Maximum inrush current		Current is limited by the overload protection function.
Leakage current at OFF		0.1mA or less
Max. voltage drop at ON		0.25VDC (TYP.) 2A, 0.5VDC (MAX.) 2A, 0.5VDC (TYP.) 4A, 0.1VDC (MAX.) 4A
Output response time	OFF → ON	0.5ms or less
	ON → OFF	0.8ms or less (resistive load)
Surge suppressor		Zener diode
External power supply for output part ^{*4}	Voltage	12/24VDC (ripple rate: 5% or less) (Allowable voltage range: 10.2 to 28.8VDC)
	Current	20mA or less (TYP. 24VDC per common) External load current is not included.
Protection function	Overload protection function	Limited current when detecting overcurrent: 9A or more/point Activated to each point.
	Overheat protection function	Activated to each point.
Wiring method for common		8 points/common (2-wire, waterproof connector type) Sink type
■Common specifications		
Station type		Remote device station
Network topology		Line topology, star topology, mixture of star topology and line topology, ring topology
Withstand voltage		720VDC for 1 minute between all DC external terminals and ground
Insulation resistance		10MΩ or higher between all DC external terminals and ground (500VDC insulation resistance tester)
Noise immunity		Noise voltage 500Vp-p, noise width 1μs, noise frequency 25 to 60Hz (DC type noise simulator condition)
Protection degree		IP67
External interface	Communication part	M12 waterproof connector, 8 pins, female, X-code
	Module power supply part	M12 waterproof connector, 5 pins, male, female, L-code
	I/O part	M12 waterproof connector, 5 pins, female, A-code
Applicable waterproof connector	For communications	☞ Page 147 List of Recommended Cables/Connectors for the I/O Module (Waterproof Module)
	For power supply	
	For I/O	
	Y-branch connector for I/O	
Multicast filter		Available
Cyclic transmission	RX/Ry points	16 points
	RWr/RWw points	4 points ^{*3}
Module power supply ^{*4}	Voltage	24VDC (ripple rate: 5% or less) (Allowable voltage range: 20.4 to 28.8VDC)
	Current	160mA or less (24VDC, all points ON)
Weight		0.42kg

- *1 If the input response time is set to "0ms", the actual input response time is 80μs at OFF → ON, and 160μs at ON → OFF.
- *2 Make sure that the total amount of output current that flows through one connector is 4A or less.
- *3 This value indicates the number of points set by default when the module is dragged and dropped to the network map in the CC IE Field Configuration window. According to the function used, set an appropriate number of points. (☞ Page 224 I/O combined module (16-point module))
- *4 For a power supply to be connected to the waterproof I/O module (such as the module-and-sensor power supply or the load power supply and external power supply for output part), use the power supply that meets the following condition.
SELV (Safety Extra Low Voltage): Product with reinforced insulation from the hazardous potential part (60V or higher)

■ Derating chart

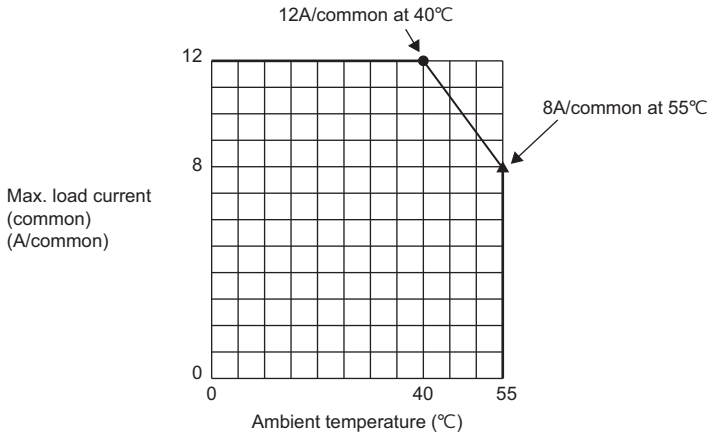

- : Module-and-sensor power supply current, 8A
- ▲: Module-and-sensor power supply current, 6A

The module-and-sensor power supply current is 6A when the ambient temperature is 40°C or higher.

External wiring

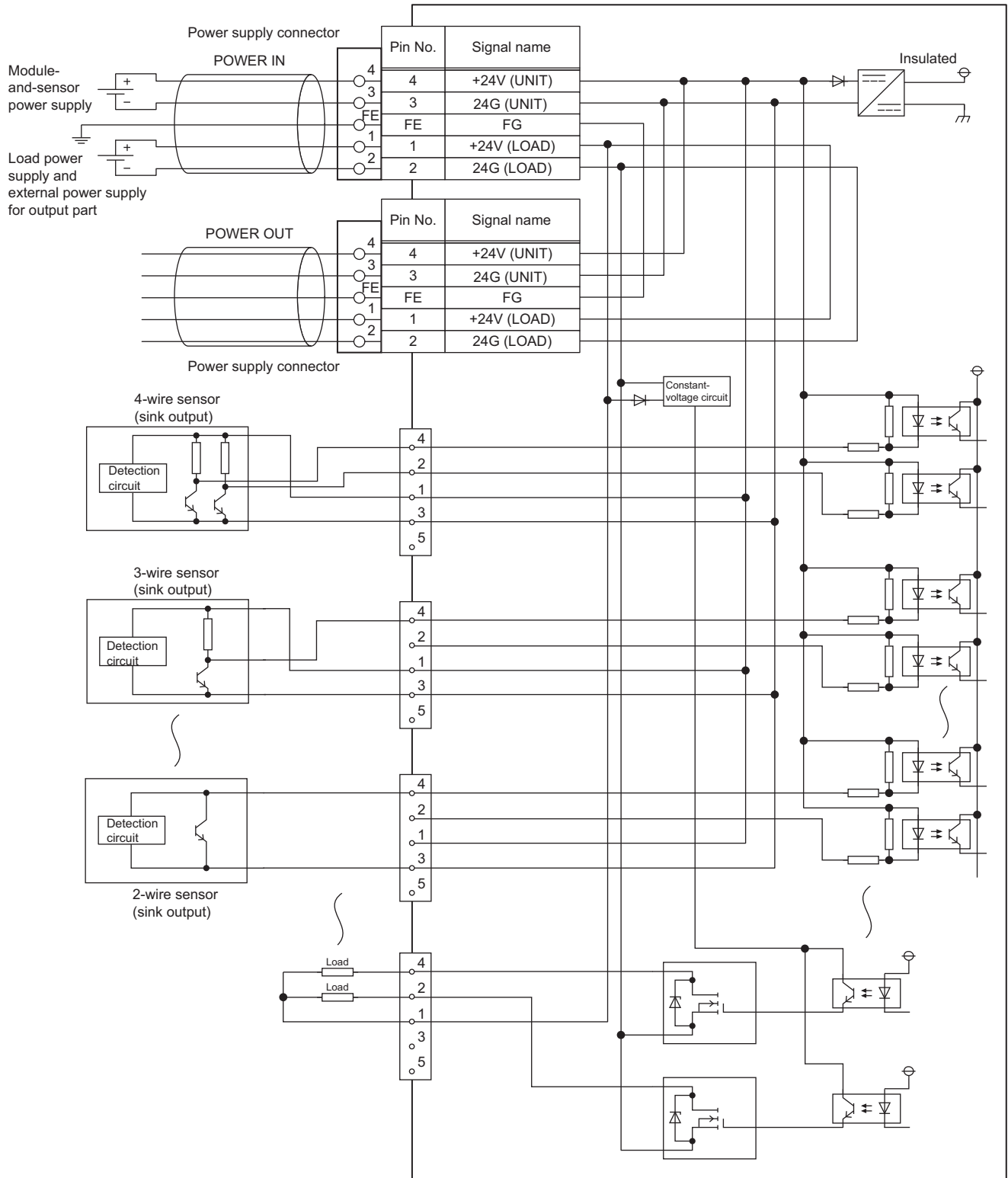

■ Power supply connectors

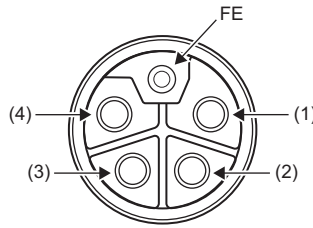
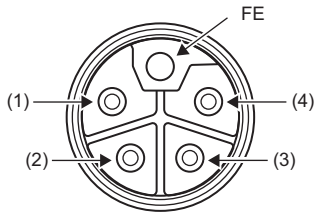

Pin number		Signal name	Pin number		Signal name
M12 connector, male (IN)	(1)	+24V (LOAD)	M12 connector, female (OUT)	(1)	+24V (LOAD)
	(2)	24G (LOAD)		(2)	24G (LOAD)
	(3)	24G (UNIT)		(3)	24G (UNIT)
	(4)	+24V (UNIT)		(4)	+24V (UNIT)
	FE	FG		FE	FG

■ Connector for I/O

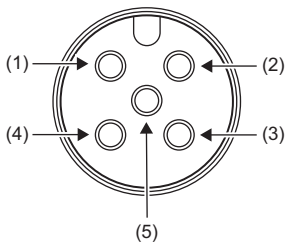

Connector for input			Connector for output		
Pin number		Signal name	Pin number		Signal name
X0 X1	(1)	+24V (UNIT)	Y8 Y9	(1)	+24V (LOAD)
	(2)	X1		(2)	Y9
	(3)	24G (UNIT)		(3)	Empty
	(4)	X0		(4)	Y8
	(5)	Empty		(5)	Empty
X2 X3	(1)	+24V (UNIT)	YA YB	(1)	+24V (LOAD)
	(2)	X3		(2)	YB
	(3)	24G (UNIT)		(3)	Empty
	(4)	X2		(4)	YA
	(5)	Empty		(5)	Empty
X4 X5	(1)	+24V (UNIT)	YC YD	(1)	+24V (LOAD)
	(2)	X5		(2)	YD
	(3)	24G (UNIT)		(3)	Empty
	(4)	X4		(4)	YC
	(5)	Empty		(5)	Empty
X6 X7	(1)	+24V (UNIT)	YE YF	(1)	+24V (LOAD)
	(2)	X7		(2)	YF
	(3)	24G (UNIT)		(3)	Empty
	(4)	X6		(4)	YE
	(5)	Empty		(5)	Empty

NZ2GN2S1-32DTE DC input/transistor output module

Item		NZ2GN2S1-32DTE
■Input specifications		
Number of input points		16 points
Rated input voltage		24VDC (ripple rate: 5% or less) (Allowable voltage range: 20.4 to 28.8VDC)
Rated input current		6.0mA TYP. (for 24VDC)
Maximum number of simultaneous input points		100%
ON voltage/ON current		11VDC or more/4mA or more
OFF voltage/OFF current		5VDC or less/1.5mA or less
Input resistance		3.3kΩ
Input response time	OFF → ON	0ms ^{*1} /0.2ms/1ms/1.5ms/5ms/10ms/20ms/70ms
	ON → OFF	(Factory default: 1ms)
Wiring method for common		16 points/common (Common terminal: terminal number 34) (1-wire, spring clamp terminal block type) Negative common type
■Output specifications		
Number of output points		16 points
Rated load voltage		24VDC (ripple rate: 5% or less) (Allowable voltage range: 20.4 to 28.8VDC)
Max. load current		0.5A/point, 4A/common
Maximum inrush current		Current is limited by the overload protection function.
Leakage current at OFF		0.1mA or less
Max. voltage drop at ON		0.5VDC (TYP.) 0.5A, 0.8VDC (MAX.) 0.5A
Output response time	OFF → ON	0.5ms or less
	ON → OFF	1.0ms or less (resistive load)
Surge suppressor		Zener diode
External power supply for output part	Voltage	24VDC (ripple rate: 5% or less) (Allowable voltage range: 20.4 to 28.8VDC)
	Current	45mA or less (TYP. 24VDC per common) External load current is not included.
Protection function	Overload protection function	Limited current when detecting overcurrent: 1.5A or more/point Activated to each point.
	Overheat protection function	Activated to each point.
Wiring method for common		16 points/common (Common terminal: terminal number 33) (1-wire, spring clamp terminal block type) Source type
■Common specifications		
Station type		Intelligent device station
Network topology		Line topology, star topology, mixture of star topology and line topology, ring topology
Withstand voltage		510VAC for 1 minute between all DC external terminals and ground
Insulation resistance		10MΩ or higher between all DC external terminals and ground (500VDC insulation resistance tester)
Noise immunity ^{*2}		Noise voltage 500Vp-p, noise width 1μs, noise frequency 25 to 60Hz (DC type noise simulator condition)
Protection degree		IP2X
External interface	Communication part	RJ45 connector
	Module power supply part	Terminal block for module power supply and FG (2-piece spring clamp terminal block)
	I/O part	2-piece spring clamp terminal block
Applicable wire size	For power supply	Stranded wire: 0.3 to 1.5mm ² (22 to 16 AWG), terminal slot size: 2.4mm × 1.5mm ^{*3}
	For I/O	Stranded wire: 0.3 to 1.5mm ² (22 to 16 AWG)
Applicable solderless terminal ^{*4}	Terminal block for module power supply and FG	☞ Page 124 Applicable solderless terminal
	I/O terminal block	☞ Page 134 Applicable solderless terminal
Cyclic transmission	RX/Ry points	32 points
	RWr/RWw points	4 points ^{*5}
Module power supply	Voltage	24VDC (ripple rate: 5% or less) (Allowable voltage range: 20.4 to 28.8VDC)
	Current	110mA or less (24VDC, all points ON)
Weight		0.20kg

- *1 If the input response time is set to "0ms", the actual input response time is 80μs at OFF → ON, and 160μs at ON → OFF.
- *2 It is the noise immunity of when the input response time setting value is other than "0ms". Note that the module is easily affected by noise if "0ms" is set.
- *3 Use bar solderless terminals for wiring.
- *4 Only one wire can be inserted into a wire insertion opening. Multiple wires cannot be connected to a terminal. Connecting two or more wires may cause a poor contact.
- *5 This value indicates the number of points set by default when the module is dragged and dropped to the network map in the CC IE Field Configuration window. According to the function used, set an appropriate number of points. (☞ Page 225 I/O combined module (32-point module))

External wiring

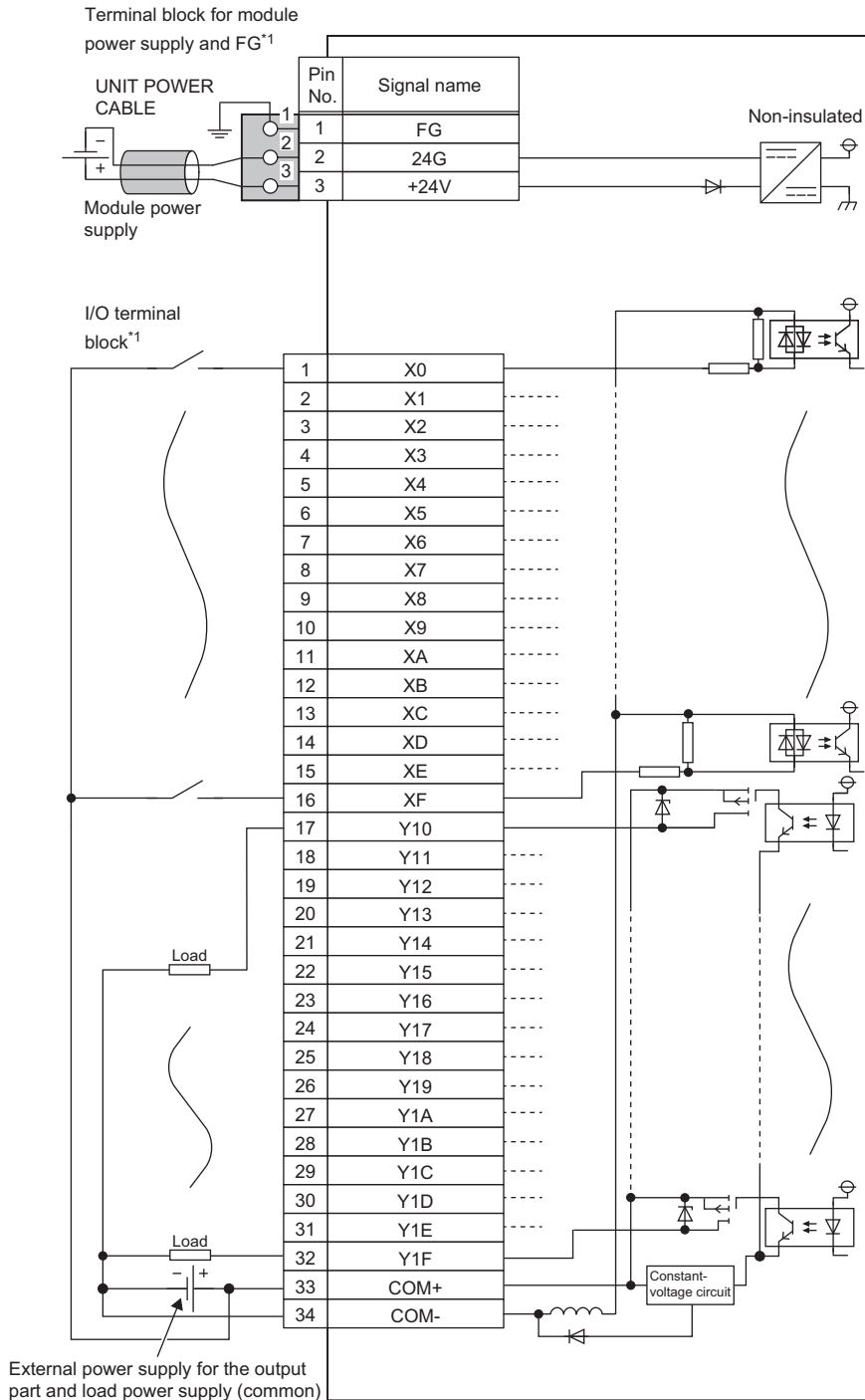

- *1 Only one wire can be inserted into a wire insertion opening. Multiple wires cannot be connected to a terminal. Connecting two or more wires may cause a poor contact.

I/O terminal block

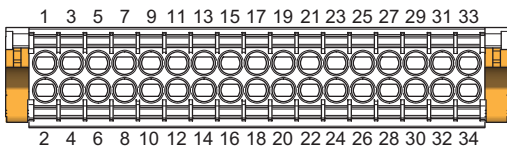

Terminal number	Signal name	Terminal number	Signal name
1	X0	17	Y10
2	X1	18	Y11
3	X2	19	Y12
4	X3	20	Y13
5	X4	21	Y14
6	X5	22	Y15
7	X6	23	Y16
8	X7	24	Y17
9	X8	25	Y18
10	X9	26	Y19
11	XA	27	Y1A
12	XB	28	Y1B
13	XC	29	Y1C
14	XD	30	Y1D
15	XE	31	Y1E
16	XF	32	Y1F
—		33	COM+
		34	COM-

NZ2GN2B1-32DTE DC input/transistor output module

Item		NZ2GN2B1-32DTE
■Input specifications		
Number of input points		16 points
Rated input voltage		24VDC (ripple rate: 5% or less) (Allowable voltage range: 20.4 to 28.8VDC)
Rated input current		6.0mA TYP. (for 24VDC)
Maximum number of simultaneous input points		100%
ON voltage/ON current		11VDC or more/4mA or more
OFF voltage/OFF current		5VDC or less/1.5mA or less
Input resistance		3.3kΩ
Input response time	OFF → ON	0ms ^{*1} /0.2ms/1ms/1.5ms/5ms/10ms/20ms/70ms
	ON → OFF	(Factory default: 1ms)
Wiring method for common		16 points/common (Common terminal: terminal number 34) (1-wire, screw terminal block type) Negative common type
■Output specifications		
Number of output points		16 points
Rated load voltage		24VDC (ripple rate: 5% or less) (Allowable voltage range: 20.4 to 28.8VDC)
Max. load current		0.5A/point, 4A/common
Maximum inrush current		Current is limited by the overload protection function.
Leakage current at OFF		0.1mA or less
Max. voltage drop at ON		0.5VDC (TYP.) 0.5A, 0.8VDC (MAX.) 0.5A
Output response time	OFF → ON	0.5ms or less
	ON → OFF	1.0ms or less (resistive load)
Surge suppressor		Zener diode
External power supply for output part	Voltage	24VDC (ripple rate: 5% or less) (Allowable voltage range: 20.4 to 28.8VDC)
	Current	45mA or less (TYP. 24VDC per common) External load current is not included.
Protection function	Overload protection function	Limited current when detecting overcurrent: 1.5A or more/point Activated to each point.
	Overheat protection function	Activated to each point.
Wiring method for common		16 points/common (Common terminal: terminal number 33) (1-wire, screw terminal block type) Source type
■Common specifications		
Station type		Intelligent device station
Network topology		Line topology, star topology, mixture of star topology and line topology, ring topology
Withstand voltage		510VAC for 1 minute between all DC external terminals and ground
Insulation resistance		10MΩ or higher between all DC external terminals and ground (500VDC insulation resistance tester)
Noise immunity ^{*2}		Noise voltage 500Vp-p, noise width 1μs, noise frequency 25 to 60Hz (DC type noise simulator condition)
Protection degree		IP2X
External interface	Communication part	RJ45 connector
	Module power supply part	Terminal block for module power supply and FG (2-piece spring clamp terminal block)
	I/O part	34-point two-piece terminal block Tightening torque range for terminal screw (M3 × 5.2 screw): 0.43 to 0.57N·m Tightening torque range for terminal block mounting screw (M3.5 screw): 0.68 to 0.92N·m
Applicable wire size	For power supply	Stranded wire: 0.3 to 1.5mm ² (22 to 16 AWG), terminal slot size: 2.4mm × 1.5mm ^{*3}
	For I/O	Stranded wire: 0.3 to 2.0mm ² (22 to 14 AWG)
Applicable solderless terminal	Terminal block for module power supply and FG ^{*4}	☞ Page 124 Applicable solderless terminal
	I/O terminal block	☞ Page 138 Applicable solderless terminal
Cyclic transmission	RX/Ry points	32 points
	RWr/RWw points	4 points ^{*5}
Module power supply	Voltage	24VDC (ripple rate: 5% or less) (Allowable voltage range: 20.4 to 28.8VDC)
	Current	110mA or less (24VDC, all points ON)
Weight		0.31kg

- *1 If the input response time is set to "0ms", the actual input response time is 80μs at OFF → ON, and 160μs at ON → OFF.
- *2 It is the noise immunity of when the input response time setting value is other than "0ms". Note that the module is easily affected by noise if "0ms" is set.
- *3 Use bar solderless terminals for wiring.
- *4 Only one wire can be inserted into a wire insertion opening for the terminal block for module power supply and FG. Multiple wires cannot be connected to a terminal. Connecting two or more wires may cause a poor contact.
- *5 This value indicates the number of points set by default when the module is dragged and dropped to the network map in the CC IE Field Configuration window. According to the function used, set an appropriate number of points. (☞ Page 225 I/O combined module (32-point module))

External wiring

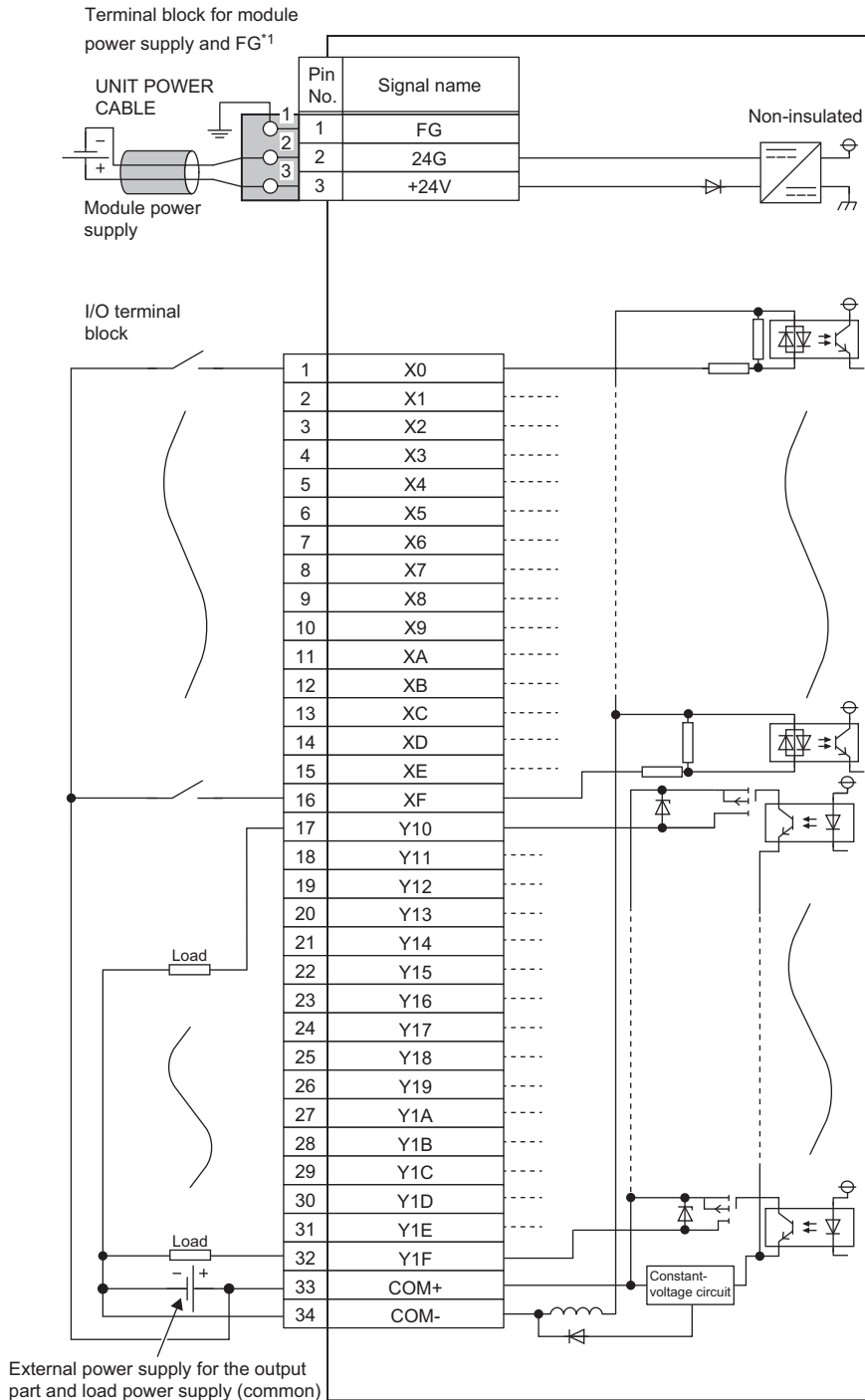

- *1 Only one wire can be inserted into a wire insertion opening for the terminal block for module power supply and FG. Multiple wires cannot be connected to a terminal. Connecting two or more wires may cause a poor contact.

■ I/O terminal block

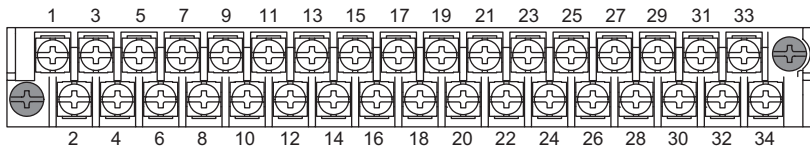

Terminal number	Signal name	Terminal number	Signal name
1	X0	17	Y10
2	X1	18	Y11
3	X2	19	Y12
4	X3	20	Y13
5	X4	21	Y14
6	X5	22	Y15
7	X6	23	Y16
8	X7	24	Y17
9	X8	25	Y18
10	X9	26	Y19
11	XA	27	Y1A
12	XB	28	Y1B
13	XC	29	Y1C
14	XD	30	Y1D
15	XE	31	Y1E
16	XF	32	Y1F
—		33	COM+
		34	COM-

NZ2GN12A42-16DTE DC input/transistor output module

Item		NZ2GN12A42-16DTE
■Input specifications		
Number of input points		8 points
Rated input voltage		24VDC (ripple rate: 5% or less) (Allowable voltage range: 20.4 to 28.8VDC)
Rated input current		7.3mA TYP. (for 24VDC)
Maximum number of simultaneous input points		100%
ON voltage/ON current		11VDC or more/4mA or more
OFF voltage/OFF current		5VDC or less/1.5mA or less
Input resistance		3.0kΩ
Input response time	OFF → ON	0ms ^{*1} /0.2ms/1ms/1.5ms/5ms/10ms/20ms/70ms
	ON → OFF	(Factory default: 10ms)
Wiring method for common		8 points/common (2- to 4-wire, waterproof connector type) Negative common type
Current supplied to external devices		0.4A/terminal
■Output specifications		
Number of output points		8 points
Rated load voltage		12/24VDC (ripple rate: 5% or less) (Allowable voltage range: 10.2 to 28.8VDC)
Max. load current		4A/point (Y8 to YB) ^{*2} , 2A/point (YC to YF), 12A/common
Maximum inrush current		Current is limited by the overload protection function.
Leakage current at OFF		0.1mA or less
Max. voltage drop at ON		0.3VDC (TYP.) 2A, 0.6VDC (MAX.) 2A, 0.6VDC (TYP.) 4A, 1.2VDC (MAX.) 4A
Output response time	OFF → ON	0.5ms or less
	ON → OFF	1.0ms or less (resistive load)
Surge suppressor		Zener diode
External power supply for output part ^{*4}	Voltage	12/24VDC (ripple rate: 5% or less) (Allowable voltage range: 10.2 to 28.8VDC)
	Current	30mA or less (TYP. 24VDC per common) External load current is not included.
Protection function	Overload protection function	Limited current when detecting overcurrent: 5.2A or more/point Activated to each point.
	Overheat protection function	Activated to each point.
Wiring method for common		8 points/common (2-wire, waterproof connector type) Source type
■Common specifications		
Station type		Remote device station
Network topology		Line topology, star topology, mixture of star topology and line topology, ring topology
Withstand voltage		720VDC for 1 minute between all DC external terminals and ground
Insulation resistance		10MΩ or higher between all DC external terminals and ground (500VDC insulation resistance tester)
Noise immunity		Noise voltage 500Vp-p, noise width 1μs, noise frequency 25 to 60Hz (DC type noise simulator condition)
Protection degree		IP67
External interface	Communication part	M12 waterproof connector, 8 pins, female, X-code
	Module power supply part	M12 waterproof connector, 5 pins, male, female, L-code
	I/O part	M12 waterproof connector, 5 pins, female, A-code
Applicable waterproof connector	For communications	☞ Page 147 List of Recommended Cables/Connectors for the I/O Module (Waterproof Module)
	For power supply	
	For I/O	
	Y-branch connector for I/O	
Multicast filter		Available
Cyclic transmission	RX/Ry points	16 points
	RWr/RWw points	4 points ^{*3}
Module power supply ^{*4}	Voltage	24VDC (ripple rate: 5% or less) (Allowable voltage range: 20.4 to 28.8VDC)
	Current	160mA or less (24VDC, all points ON)
Weight		0.42kg

- *1 If the input response time is set to "0ms", the actual input response time is 80 μ s at OFF \rightarrow ON, and 160 μ s at ON \rightarrow OFF.
- *2 Make sure that the total amount of output current that flows through one connector is 4A or less.
- *3 This value indicates the number of points set by default when the module is dragged and dropped to the network map in the CC IE Field Configuration window. According to the function used, set an appropriate number of points. (☞ Page 224 I/O combined module (16-point module))
- *4 For a power supply to be connected to the waterproof I/O module (such as the module-and-sensor power supply or the load power supply and external power supply for output part), use the power supply that meets the following condition.
SELV (Safety Extra Low Voltage): Product with reinforced insulation from the hazardous potential part (60V or higher)

■ Derating chart

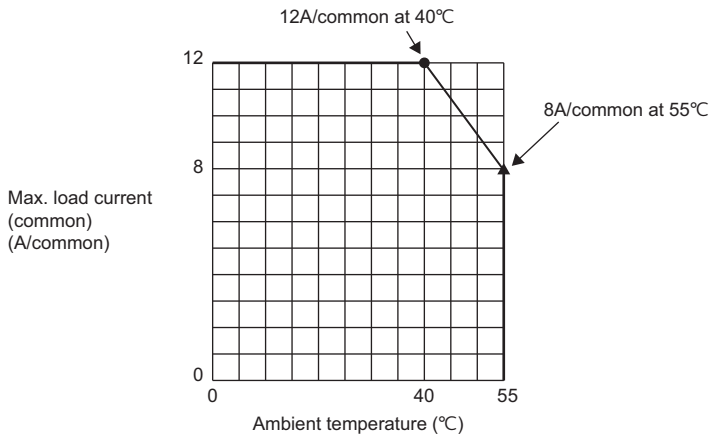

- : Module-and-sensor power supply current, 8A
- ▲: Module-and-sensor power supply current, 6A

The module-and-sensor power supply current is 6A when the ambient temperature is 40°C or higher.

External wiring

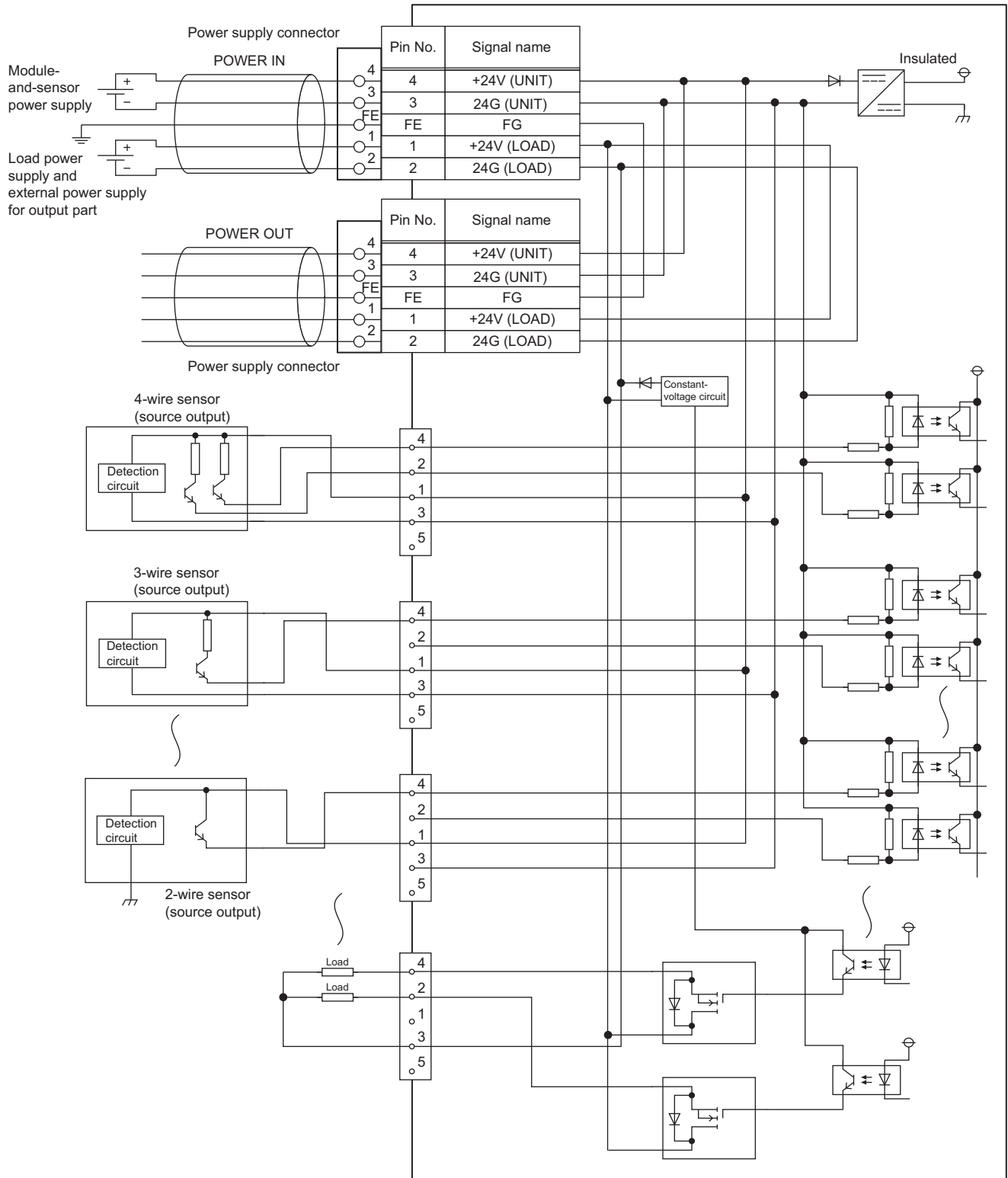

■ Power supply connectors

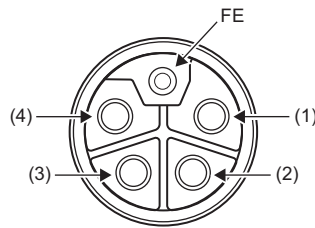
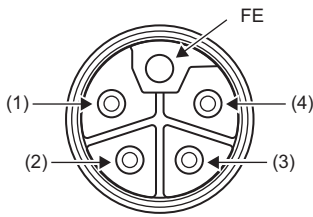

Pin number		Signal name	Pin number		Signal name
M12 connector, male (IN)	(1)	+24V (LOAD)	M12 connector, female (OUT)	(1)	+24V (LOAD)
	(2)	24G (LOAD)		(2)	24G (LOAD)
	(3)	24G (UNIT)		(3)	24G (UNIT)
	(4)	+24V (UNIT)		(4)	+24V (UNIT)
	FE	FG		FE	FG

■ Connector for I/O

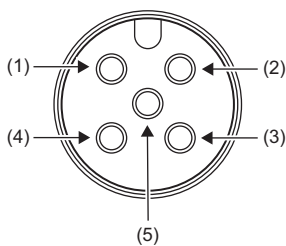

Connector for input			Connector for output		
Pin number		Signal name	Pin number		Signal name
X0 X1	(1)	+24V (UNIT)	Y8 Y9	(1)	Empty
	(2)	X1		(2)	Y9
	(3)	24G (UNIT)		(3)	24G (LOAD)
	(4)	X0		(4)	Y8
	(5)	Empty		(5)	Empty
X2 X3	(1)	+24V (UNIT)	YA YB	(1)	Empty
	(2)	X3		(2)	YB
	(3)	24G (UNIT)		(3)	24G (LOAD)
	(4)	X2		(4)	YA
	(5)	Empty		(5)	Empty
X4 X5	(1)	+24V (UNIT)	YC YD	(1)	Empty
	(2)	X5		(2)	YD
	(3)	24G (UNIT)		(3)	24G (LOAD)
	(4)	X4		(4)	YC
	(5)	Empty		(5)	Empty
X6 X7	(1)	+24V (UNIT)	YE YF	(1)	Empty
	(2)	X7		(2)	YF
	(3)	24G (UNIT)		(3)	24G (LOAD)
	(4)	X6		(4)	YE
	(5)	Empty		(5)	Empty

3.3 Function List

This section lists the functions of I/O modules.

○: Available, —: Not available

Item	Description	Function availability			Reference
		Input module	Output module	I/O combined module	
Input response time setting function	Prevents an incorrect input due to noise by setting the response time required for the module to recognize an actual input as the X signal.	○	—	○	Page 152 Input Response Time Setting Function
Output HOLD/CLEAR setting function	Sets whether to hold or clear the last output value when the I/O module is disconnected from data link, when the CPU module operating status is STOP, or when the CPU module operation is suspended by an error.	—	○	○	Page 153 Output HOLD/CLEAR Setting Function
CC-Link IE Field Network synchronous communication function	Performs I/O with a synchronization cycle of the master station that supports the CC-Link IE Field Network synchronous communication function.	○	○	○	Page 154 CC-Link IE Field Network Synchronous Communication Function
Output ON/OFF information hold function	Checks whether the output has been turned on or off.	—	○	○	Page 167 Output ON/OFF Information Hold Function
Fast link-up function	Shortens the time taken for data link establishment with the master station at power-on.	○	○	○	Page 163 Fast Link-Up Function
Protection function	The transistor output module and the I/O combined module (transistor output part) have the overload protection function and the overheat protection function.	—	○	○	Page 168 Protection Function
Module power supply voltage drop detection function	Detects a voltage drop of the module power supply.	○	○	○	Page 169 Module Power Supply Voltage Drop Detection Function
External power supply monitoring function	Monitors the ON/OFF status of the external power supply.	—	○	○	Page 169 External Power Supply Monitoring Function
Firmware update function	Updates the firmware of the I/O module via CC-Link IE TSN.	○	○	○	Page 170 Firmware Update Function

4 PROCEDURES BEFORE OPERATION

This chapter describes the procedures before operation.

1. Setting the IP address/station number setting switches

Set the fourth octet of IP address of I/O module.

Set the station number of the I/O module.

 Page 115 Setting the IP address/station number setting switches

2. Function setting switch setting

Set functions of the I/O module.

To operate the module in CC-Link IE Field Network communication mode, set function setting switch 1 to ON.

In the factory default switch state, the I/O module also operates with the following settings. Change the switch status as necessary.

- Input response time setting: 1ms (I/O module (except for waterproof module)), 10ms (I/O module (waterproof module))
- Output HOLD/CLEAR setting: CLEAR
- CC-Link IE Field Network synchronous communication mode setting function: Synchronous X/Y control mode
- Fast link-up function: Disabled

 Page 117 Function setting switch setting

3. Connection

Mount the I/O modules (except for waterproof modules) on a DIN rail. Or fix the I/O modules (waterproof modules).

 Page 122 Mounting the I/O modules (except for waterproof module) on a DIN rail

 Page 123 Fixing the I/O module (waterproof module)

4. Wiring

Wire the power supply, Ethernet cables, and external devices to the I/O modules.

 Page 124 Wiring of Terminal Block for Module Power Supply and FG

 Page 130 Wiring the I/O Module (Waterproof Module) to the Power Supply

 Page 131 Wiring of Ethernet Cable

 Page 134 Wiring of I/O Module and External Device

5. Parameter setting

Set the network parameters.

 Page 150 Network Configuration Setting

6. Programming

Create a program.

Point

To replace the I/O module, follow the procedure described below:

- Power off the I/O module and remove it.
 - Prepare a new I/O module and perform the procedure from step 1 to step 4. At this time, the settings of the IP address/station number setting switches and function setting switch must be the same as the settings for I/O module before replacement.
 - Check that the RUN LED and DATA LINK LED of I/O module are on and the ERR. LED is off before restarting control operation.
-

5 SYSTEM CONFIGURATION

This chapter describes system configuration using an I/O module.
For CC-Link IE Field Network configuration, refer to the following.

 User's manual for the master/local module used

5.1 Applicable Systems

Applicable master station

When using an I/O module, use the following products as a master station.

Model	First five digits of serial number
RJ71GF11-T2	No restriction
RJ71EN71	
RnENCPU	
RD77GF32, RD77GF16, RD77GF8, RD77GF4	
QJ71GF11-T2	The first five digits of the serial number are "14102" or later.
LJ71GF11-T2	
QD77GF8, QD77GF4	The first five digits of the serial number are "17101" or later.
QD77GF16	The first five digits of the serial number are "17102" or later.

The above information of "applicable master station" is information at the time of this manual's issuance.

For the latest information, refer to the CC-Link Partner Association's homepage.

www.cc-link.org

Compatible software version

For the compatible software version, always keep the engineering tool of the master station up to date.

The compatible engineering tool is GX Works3 or GX Works2.

When the latest software is necessary, please consult your local Mitsubishi representative.

Compatible software package

Diagnosing the I/O module requires GX Works3 or GX Works2.

Install GX Works3 or GX Works2 with the following version in accordance with the I/O module used.

Model	Software version	
	GX Works3	GX Works2
NZ2GN2S1-32D, NZ2GN2B1-32D, NZ2GN2S1-32T, NZ2GN2B1-32T, NZ2GN2S1-32TE, NZ2GN2B1-32TE, NZ2GN2S1-32DT, NZ2GN2B1-32DT, NZ2GN2S1-32DTE, NZ2GN2B1-32DTE	1.060N or later	1.590Q or later
NZ2GNCF1-32D, NZ2GNCE3-32D, NZ2GNCF1-32T, NZ2GNCE3-32DT	1.065T or later	1.595V or later
NZ2GN2S1-16D, NZ2GN2B1-16D, NZ2GN12A4-16D, NZ2GN12A4-16DE, NZ2GN2S1-16T, NZ2GN2B1-16T, NZ2GN12A2-16T, NZ2GN2S1-16TE, NZ2GN2B1-16TE, NZ2GN12A2-16TE, NZ2GN12A42-16DT, NZ2GN12A42-16DTE	1.075D or later	1.605F or later

Applicable profile

A profile is required to use the I/O module in the CC IE Field Configuration setting.

The following table shows the applicable profile versions.

Model	Firmware version	Version
NZ2GN2S1-32D, NZ2GN2B1-32D, NZ2GN2S1-32T, NZ2GN2B1-32T, NZ2GN2S1-32TE, NZ2GN2B1-32TE, NZ2GN2S1-32DT, NZ2GN2B1-32DT, NZ2GN2S1-32DTE, NZ2GN2B1-32DTE	"02" or later	"00" or later
NZ2GNCF1-32D, NZ2GNCE3-32D, NZ2GNCF1-32T, NZ2GNCE3-32DT	"02" or later	"00" or later
NZ2GN2S1-16D, NZ2GN2B1-16D, NZ2GN12A4-16D, NZ2GN12A4-16DE, NZ2GN2S1-16T, NZ2GN2B1-16T, NZ2GN12A2-16T, NZ2GN2S1-16TE, NZ2GN2B1-16TE, NZ2GN12A2-16TE, NZ2GN12A42-16DT, NZ2GN12A42-16DTE	"05" or later	"00" or later

When the latest profile of the I/O module is necessary, please consult your local Mitsubishi representative.

The profile is a setting file that stores information required for the start-up, operation, and maintenance of devices supporting the CC-Link family.

A module is added to "Module List" of the CC IE Field Configuration window by profile registration to the engineering tool of the master station.



For the profile registration, refer to the following.

 GX Works3 Operating Manual

 GX Works2 Version 1 Operating Manual (Common)

Ethernet cable

For the specifications of the Ethernet cable, refer to the following.

- When using the I/O modules (except for waterproof modules):  User's manual for the master station used
- When using the I/O modules (waterproof modules):  Page 147 List of Recommended Cables/Connectors for the I/O Module (Waterproof Module)

Hub

For compatible hubs, refer to the following.

 User's manual for the master/local module used

6 INSTALLATION AND WIRING

This chapter describes the installation and wiring of the I/O module.

6.1 Before Using the I/O Modules

Input modules

Precautions common to all input modules

■Number of simultaneous ON points

The number of input points that can be turned on at the same time varies depending on the input voltage and ambient temperature. Refer to the maximum number of simultaneous input points of the specifications of each input module. (☞ Page 21 Input module, ☞ Page 79 I/O combined module)

Precautions when using the DC input module

■Measures against back EMF

When connecting an inductive load, connect a diode in parallel with the load. Use the diode that satisfies the following conditions:

- A reverse breakdown voltage is ten times as high as the circuit voltage or more.
- A forward current is twice as high as the load current or more.

Positive common type	Negative common type

■Input response time

For the input module and I/O combined module, the input response time can be set. (☞ Page 152 Input Response Time Setting Function)

In a circumstance where noise tends to occur, the noise in an input can be reduced by making the input response time longer, which makes the input status more stable.

The factory default input response time is as follows.

- I/O module (except for waterproof module): 1ms
- I/O module (waterproof module): 10ms

Output modules

Precautions common to all output modules

■Maximum switching frequency when L load is driven

The maximum switching frequency imposes a limit on the use; an ON state or an OFF state must not be changed without an interval of at least one second.

■Load to be connected

When connecting a counter or timer utilizing a DC-DC converter as a load of the output module, select an output module whose maximum load current is higher than the inrush current of a load to be connected. If the selection is based on the average current of a load to be connected, an inrush current flows cyclically from the load while the output module is in an ON state or in operation, which can cause failure of the output module. If it is necessary to select an output module on the basis of the average current of a load to be connected, to alleviate the effect of the inrush current, take any of the following corrective actions:

- Connecting a resistor in series with the load

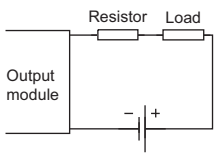

- Connecting an inductor in series with the load

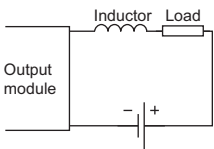

Precautions when using the transistor output module

Measures against reverse current

In the following connections, a reverse current flows to the output element, which can cause failure.

When wiring, set up diodes as the following figures show:

- When connecting transistor output modules in parallel

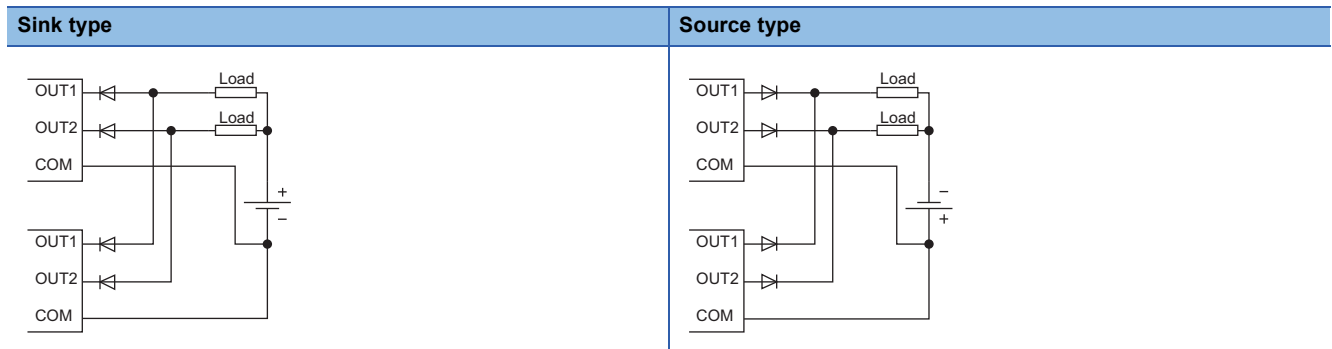

- When providing another circuit in parallel with a transistor output module

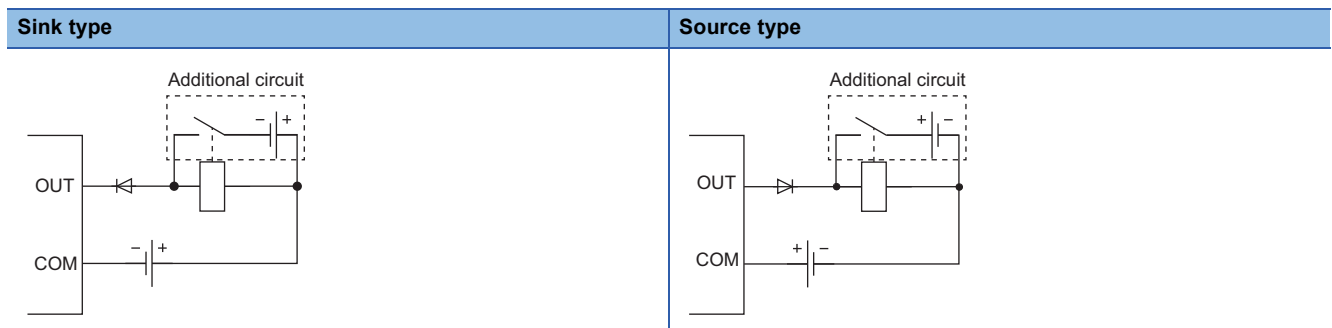

Measures against back EMF

When connecting an inductive load, connect a diode in parallel with the load.

Use the diode that satisfies the following conditions:

- A reverse breakdown voltage is ten times as high as the circuit voltage or more.
- A forward current is twice as high as the load current or more.

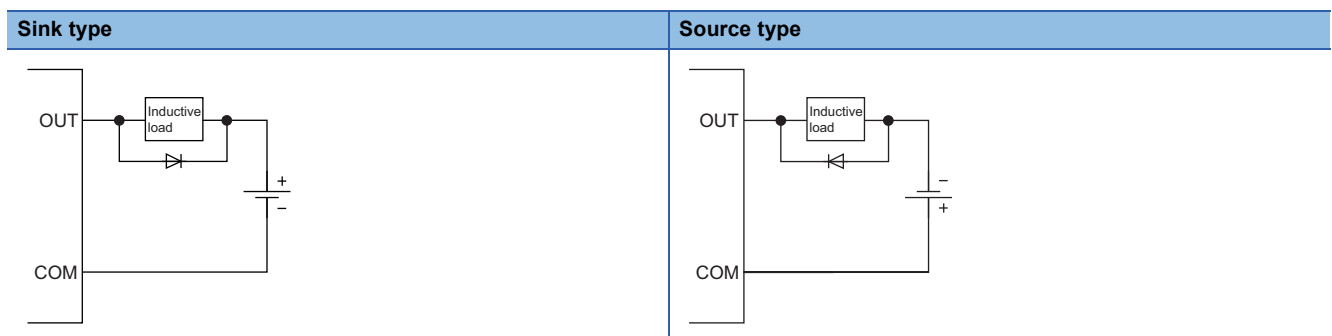

About element protection of the output module

If excessive noise affects the terminals of the output module, the output may be turned on to help the protection of the output element. Adjust the voltage between terminals of the output module to fall within the operating load voltage range by taking measures such as the following:

- To use an inductive load such as a relay, a surge suppressor is required on the load side as well. Take appropriate measures with the measures against back EMF as a guide.
- To prevent excessive noise, avoid installing power cables together with I/O cables.

I/O combined module

There are no precautions specific to I/O combined modules. Refer to the following precautions.

☞ Page 110 Input modules

☞ Page 111 Output modules

6.2 Setting Switch

Indicator cover of the I/O module (waterproof module)

To operate the setting switches of the I/O module (waterproof module), loosen the screws for the indicator cover with the screwdriver and open the cover. After finishing the operation, be sure to close the indicator cover and tighten the screws. When the cover is open or the screws have not been tightened properly, waterproof performance is lost.

Tightening torque

Tighten the screws for the indicator cover within the following tightening torque range.

Screw type	Tightening torque range
Indicator cover screw (M3 screw)	0.43 to 0.57N·m

Point

- Do not put oil on the screws. Doing so may damage the screws.
- Tighten the screws with an applicable screwdriver. Tightening with an inapplicable screwdriver may damage the screws.

Setting the IP address/station number setting switches

Set the station number using the IP address/station number setting switches on the front of the I/O module.
 The setting of the IP address/station number setting switches is enabled when the I/O module is powered on. Therefore, set this function when the module is powered off.

Point 

When operating the IP address/station number setting switches, use a flathead screwdriver with a tip width of 2.5mm or less.

Setting method

Set the station number using the IP address/station number setting switches x1 and x16 (hexadecimal).
 Combinations of x1 and x16 are as follows.

		x1															
		0	1	2	3	4	5	6	7	8	9	A	B	C	D	E	F
x16	0	0	1	2	3	4	5	6	7	8	9	10	11	12	13	14	15
	1	16	17	18	19	20	21	22	23	24	25	26	27	28	29	30	31
	2	32	33	34	35	36	37	38	39	40	41	42	43	44	45	46	47
	3	48	49	50	51	52	53	54	55	56	57	58	59	60	61	62	63
	4	64	65	66	67	68	69	70	71	72	73	74	75	76	77	78	79
	5	80	81	82	83	84	85	86	87	88	89	90	91	92	93	94	95
	6	96	97	98	99	100	101	102	103	104	105	106	107	108	109	110	111
	7	112	113	114	115	116	117	118	119	120	121	122	123	124	125	126	127
	8	128	129	130	131	132	133	134	135	136	137	138	139	140	141	142	143
	9	144	145	146	147	148	149	150	151	152	153	154	155	156	157	158	159
	A	160	161	162	163	164	165	166	167	168	169	170	171	172	173	174	175
	B	176	177	178	179	180	181	182	183	184	185	186	187	188	189	190	191
	C	192	193	194	195	196	197	198	199	200	201	202	203	204	205	206	207
	D	208	209	210	211	212	213	214	215	216	217	218	219	220	221	222	223
	E	224	225	226	227	228	229	230	231	232	233	234	235	236	237	238	239
	F	240	241	242	243	244	245	246	247	248	249	250	251	252	253	254	255

Ex.

To set to 30:

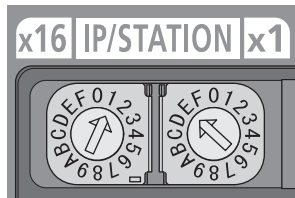

Setting range

Set a value in the range of 1 to 120.

When a value outside the range is set, an IP address/station number setting switch out of range error (error code: 0106H) occurs, and the DATA LINK LED flashes.

Point

- Do not change the IP address/station number setting switches while the I/O module is powered on. If the IP address/station number setting switches are changed while the I/O module is powered on, an IP address/station number setting switch changed error (error code: 0200H) occurs, and the ERR. LED flashes. After setting the IP address/station number setting switches back to the previous setting, turn on Error clear request flag (RWw0.b10) to clear the error state and turn off the ERR. LED.
- Do not set a station number duplicated with other station numbers. If a station number is duplicated, a communication error occurs and the DATA LINK LED does not turn on.

Precautions

When operating switches, use products for static elimination or an antistatic screwdriver, or touch a conducting object such as a grounded metal to discharge the static electricity from the human body. Failure to do so may cause the module to fail or malfunction.

Function setting switch setting

Set the following functions using the function setting switch on the front of I/O module.

- Network setting function
- Input response time setting function
- Output HOLD/CLEAR setting function
- CC-Link IE Field Network synchronous communication function
- Fast link-up function

The setting of function setting switch is enabled when the I/O module is powered on. Thus, set each function when the module is powered off.





Point 

When operating the function setting switch, use a flathead screwdriver having a blade of 1.2mm or less in width.

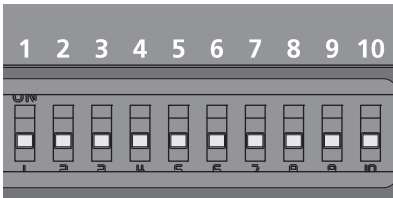
Setting procedure

Set each function with function setting switch 1 to function setting switch 10.



Switch name	Function name	Function name	Setting details
Function setting switch 1	NETWORK	Network setting function	<ul style="list-style-type: none"> • OFF: CC-Link IE TSN communication mode (Factory default)^{*1} • ON: CC-Link IE Field Network communication mode Set it to ON to perform a unit test. ( Page 192 Unit Test)
Function setting switch 2 to function setting switch 4	RESPONSE	Input response time setting function	Set the input response time. ( Page 152 Setting method)
Function setting switch 5	HOLD/CLEAR	Output HOLD/CLEAR setting function	Set output HOLD/CLEAR. ( Page 153 Setting method)
Function setting switch 6 Function setting switch 7	MODE	CC-Link IE Field Network synchronous communication mode setting function	Set the operation mode for the CC-Link IE Field Network synchronous communication function. ( Page 161 Setting method)
Function setting switch 8 Function setting switch 9	F LINK P1/P2	Fast link-up function	Set the fast link-up function. ( Page 164 Setting method)
Function setting switch 10	LINK SPEED	Use prohibited	Fix this switch to OFF.

*1 When using the I/O module in CC-Link IE TSN communication mode, refer to the following.

 CC-Link IE TSN Remote I/O Module User's Manual (CC-Link IE TSN Communication Mode)

Point 

Do not change any function setting switch while the I/O module is powered on. If the setting of a function setting switch is changed while the I/O module is powered on, one of the errors from Function setting switch 1 changed error (error code: 0201H) to Function setting switch 10 changed error (error code: 020AH) occurs, and the changed setting of that function setting switch is not applied. Returning the function setting switch to its previous position and turning on Error clear request flag (RWw0.b10) eliminate the error.

Precautions

Slide one function setting switch at a time horizontally. Do not hold the screwdriver at an angle or pivot it off the edge of the case while working a function setting switch, since damage or deformation may result.

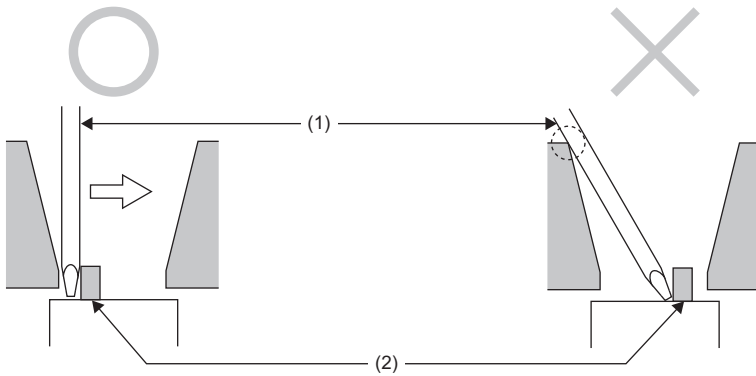

- (1) Flathead screwdriver
- (2) Function setting switch

6.3 Installation Environment and Installation Position

Installation environment

Installation location

Do not install the I/O module to the following environment:

■ I/O module (except for waterproof module)

- Ambient temperature is outside the range from 0 to 55°C;
- Ambient humidity is outside the range from 5 to 95% RH;
- Condensation occurs due to rapid temperature change;
- Corrosive gas or combustible gas is present;
- Conductive powder such as dust and iron powder, oil mist, salinity, or organic solvent is filled;
- The I/O module is exposed to direct sunlight;
- A strong electric field or strong magnetic field is generated; and
- The I/O module is subject to vibration and shock.

■ I/O module (waterproof module)

- Ambient temperature is outside the range from 0 to 55°C;
- IP67 is not satisfied;
- Condensation occurs due to rapid temperature change;
- Corrosive gas or combustible gas is present;
- Conductive powder such as dust and iron powder, oil mist, salinity, or organic solvent is filled;
- The I/O module is exposed to direct sunlight;
- A strong electric field or strong magnetic field is generated; and
- The I/O module is subject to vibration and shock.

Installation surface

Install the I/O module on the flat surface. When the installation surface is uneven, excessive force is applied to the printed-circuit board and may cause a defect.

Installation position

I/O module (except for waterproof module)

When installing the I/O module (except for waterproof module) in a control panel, provide a clearance of 60mm or more (1) between the module and the sides of the control panel or other parts to ensure good ventilation and facilitate module change. When installing two or more CC-Link IE TSN remote modules next to each other, they can be installed in contact with each other.

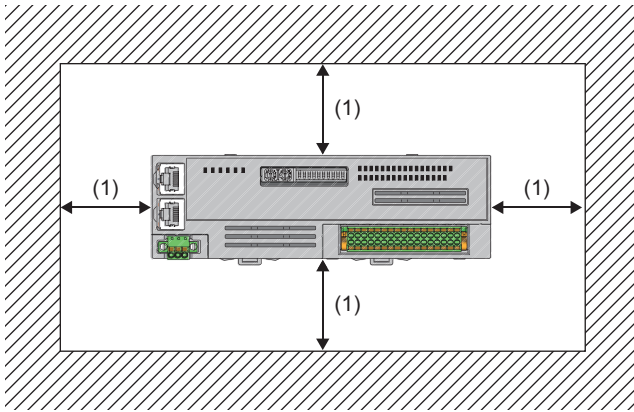

I/O module (waterproof module)

When installing the I/O module (waterproof module) in a control panel, provide a clearance of 50mm or more (1) between the module and the sides of the control panel or other parts to ensure good ventilation and facilitate module change.

When installing two or more CC-Link IE TSN remote modules next to each other, they can be installed in contact with each other.

When using a right-angle, waterproof connector or a Y-branch connector, however, provide a clearance to avoid stress on cables.

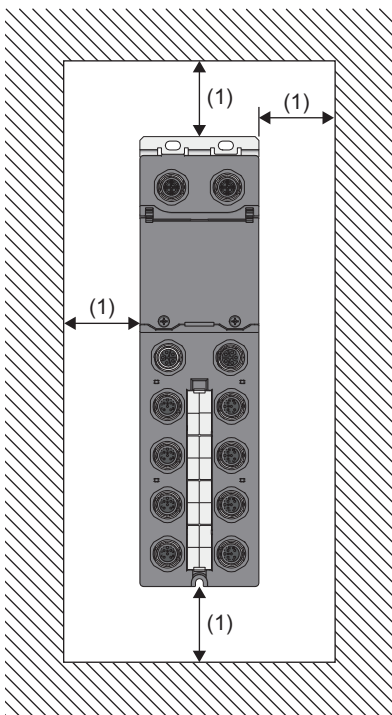

Installation direction

The I/O module can be installed in six directions.

Use the DIN rail to install the I/O module (except for waterproof module). Note that the DIN rail cannot be used to install the I/O module (waterproof module).

Ex.

Installing the I/O module (except for waterproof module)

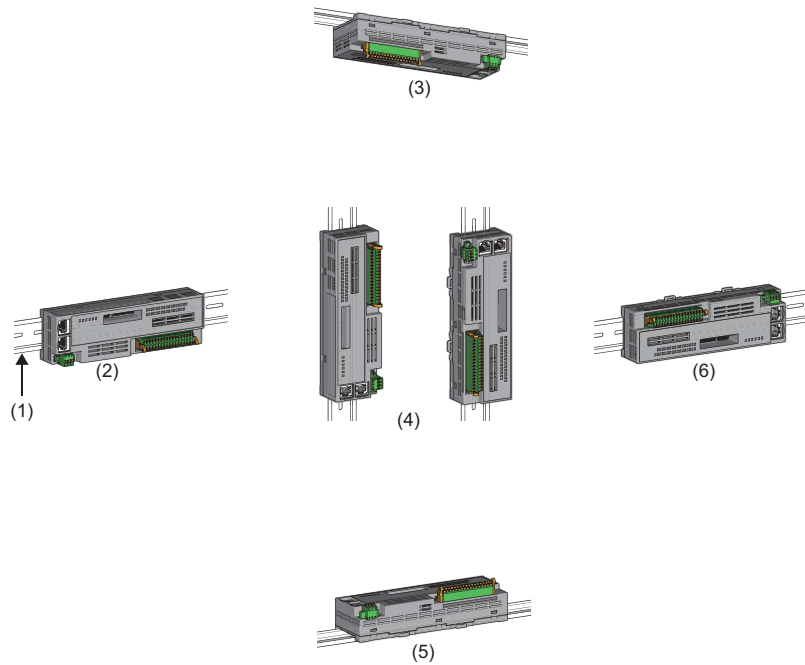

- (1) DIN rail
- (2) Horizontal installation
- (3) Downward installation
- (4) Vertical installation
- (5) Upward installation
- (6) Horizontal installation (upside down)

6.4 Installation

Mounting the I/O modules (except for waterproof module) on a DIN rail

Installation procedure

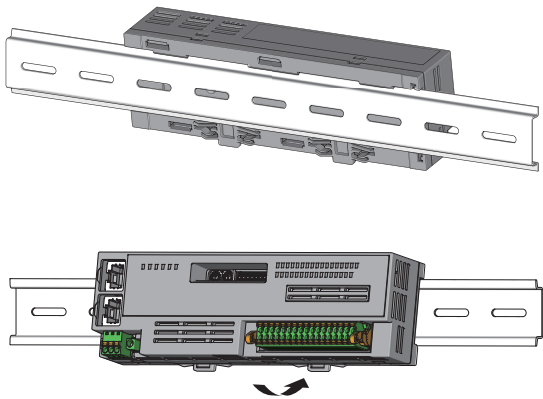

1. Hang the upper tabs of the I/O module (except for waterproof module) on a DIN rail.
2. Push in the DIN rail hooks of the module until they click.

Point

Do not slide modules from the edge of the DIN rail when mounting them. The modules may be damaged.

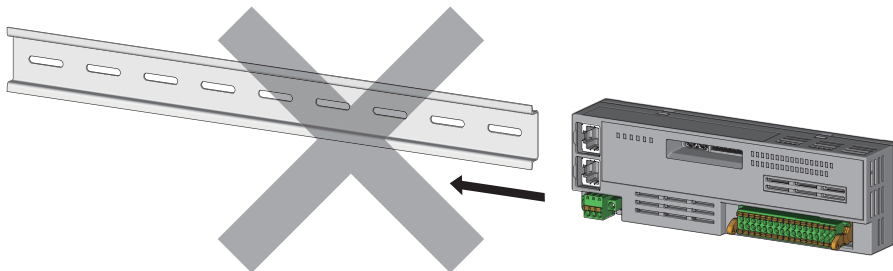

Removal procedure

Remove the modules from the DIN rail by reversing the above procedure.

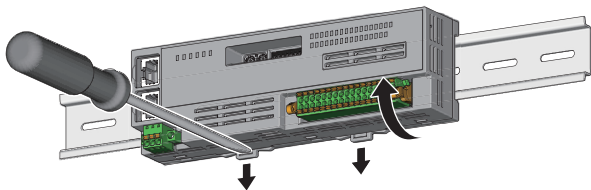

1. While pushing down the DIN rail hook with a flathead screwdriver, remove the module from the DIN rail by pulling its lower part toward you.

Applicable DIN rail models

Use the following DIN rails that are compliant with JIS C 2812 and IEC 60715.

- TH35-7.5Fe
- TH35-7.5Al

Interval between DIN rail mounting screws

Tighten the screws at intervals of 200mm or less.

Fixing the I/O module (waterproof module)

When fixing the I/O module (waterproof module), tighten all of three screws.

If any of the screws is loose, the module will be greatly affected by vibration, causing failure of the module.

When installing the module, tighten screws within the following torque range.

Screw type	Tightening torque range
Module mounting screw/FG metal fitting screw (M4 screw)	0.83 to 1.11N·m

Point

- Do not put oil on the screws. Doing so may damage the screws.
- Tighten the screws with an applicable screwdriver. Tightening with an inapplicable screwdriver may damage the screws.

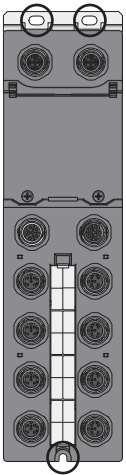

6.5 Wiring of Terminal Block for Module Power Supply and FG

Tightening torque

Tighten the terminal block mounting screws within the following specified torque range.

Tightening the screws too much may damage the case of I/O module (except for waterproof module).

Screw type	Tightening torque range
Terminal block mounting screw (M2.5 screw)	0.2 to 0.3 N·m

Wire to be used

The following table describes the wire to be connected to the terminal block for module power supply and FG.

Diameter	Type	Material	Temperature rating
22 to 16 AWG	Stranded	Copper	75°C or more

Applicable solderless terminal

The following table lists the applicable solderless terminal.

Product name	Terminal shape	Model	Applicable wire size	Bar solderless terminal tool	Contact	
Bar solderless terminal	Ferrule (with insulation sleeve)	TE0.5-8, TE0.5-10	0.3 to 0.5mm ²	NH-79A	NICHIFU Co., Ltd.	
		TE0.75-8, TE0.75-10	0.75mm ²			
		A10.34-10TQ	0.34mm ²	CRIMPFOX6		PHOENIX CONTACT GmbH & Co. KG
		A10.5-10WH	0.5mm ²			
		A10.75-10GY	0.75mm ²			
	Ferrule (without insulation sleeve)	A0.5-10	0.5mm ²			
		A0.75-10	0.75mm ²			
		A1.0-10	1.0mm ²			
		A1.5-10	1.5mm ²			

Installing and removing the terminal block

To remove the terminal block, loosen the terminal block mounting screws with a flathead screwdriver.

To install the terminal block, tighten the terminal block mounting screw with a flathead screwdriver.

Failure to secure the terminal block may cause drop, short circuit, or malfunction.

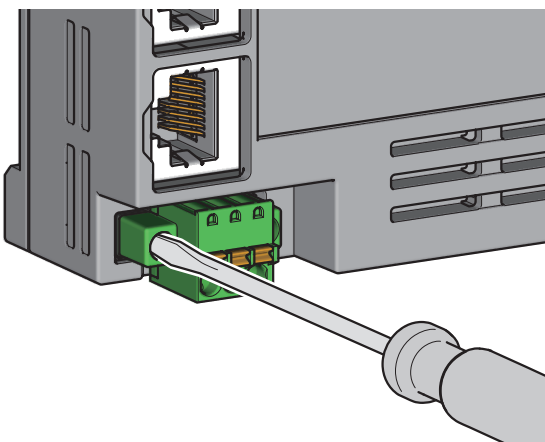

Connecting and disconnecting the cable

To connect the cable, fully insert a wire with a bar solderless terminal into a wire insertion opening.
After inserting the wire, pull it lightly to check that it is securely clamped.

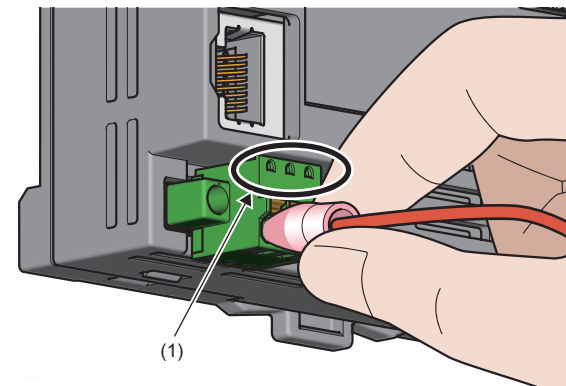

Point

Continuity can be checked with test terminal (1).

Use the following test plug to check continuity.

- PHOENIX CONTACT GmbH & Co. KG test plug ($\phi 1.0\text{mm}$): MPS-MT 1-S4-B RD, MPS-MT 1-S

To disconnect the cable, push in the open/close button with a flathead screwdriver.

With the button pushed in, pull out the wire having a bar solderless terminal.

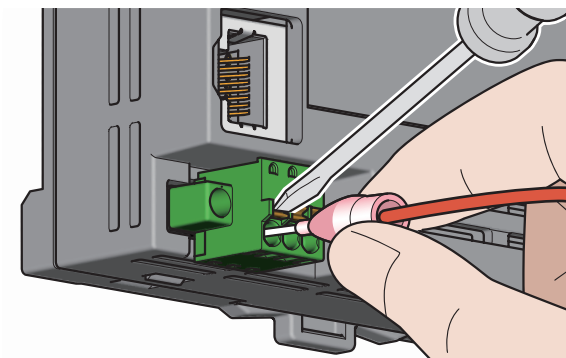

Precautions

- Use a bar solderless terminal for the wiring to the push-in type spring clamp terminal block. If a stripped wire is inserted into a wire insertion opening, the wire cannot be securely clamped.
- For how long the wire should be stripped, follow the specifications of the bar solderless terminal used. To attach a bar solderless terminal to a wire, use a crimping tool.
- Before inserting a bar solderless terminal into a wire insertion opening (1), check the shape of the opening and the shape of the terminal. Insert the terminal paying attention to the orientation. If a bar solderless terminal larger than wire insertion opening (1) is inserted, the terminal block may be damaged.

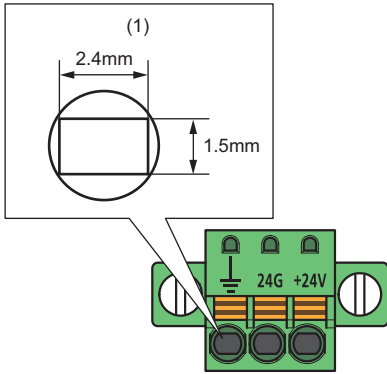

6.6 Wiring of Connector for Module Power Supply and FG

Applicable plugs

The following table lists plugs applicable to the connector for power supply and FG.

Product name	Model name of Mitsubishi Electric product	Model name of part ^{*6}	Specifications			Color of the cover
			Applicable cable (core wire size)	Applicable cable (outer diameter)	Maximum rated current	
One-touch connector plug for power supply and FG ^{*1*3*4}	A6CON-PW5P	35505-6080-A00 GF	0.75mm ² (0.66 to 0.98mm ²) (18 AWG) 0.16mm or larger for wire diameter Insulating coating material PVC (heat resistant vinyl)	φ2.2 to 3.0mm	7A ^{*5}	Gray
	A6CON-PW5P-SOD	35505-6180-A00 GF		φ2.0 to 2.3mm		Blue
Online connector for power supply and FG ^{*2}	A6CON-PWJ5P	35720-L200-A00 AK	—	—	—	—

- *1 One order of Mitsubishi Electric A6CON-□□5P includes 10 plugs.
- *2 One order of Mitsubishi Electric A6CON-□□J5P includes 5 plugs.
- *3 One-touch connector plugs cannot be reused once crimped.
- *4 Check the outer diameter of the applicable cable before selecting a connector.
- *5 The allowable current values of the cables connected must be observed.
- *6 Contact (manufacturer of the plugs): 3M Japan Limited

Wiring procedure

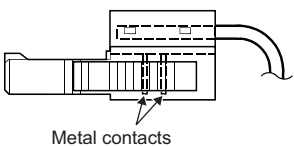
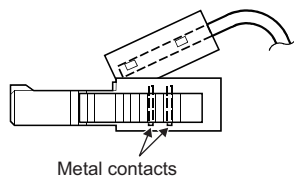
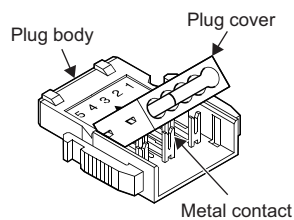

1. Checking parts of the connector

Check that the plug cover is attached to the plug body. Do not push the plug cover into the plug body before inserting cables. Once clamped, the plug cannot be reused.

2. Inserting cables

Lift the rear part of the plug cover, and insert a cable fully to the end of the plug cover. If a cable is not inserted fully, it may cause a poor crimping. The cables to be inserted must be applicable cables.

3. Setting the plug cover

After inserting cables, push down the rear part of the plug cover so that the plug cover is engaged with metal contacts.

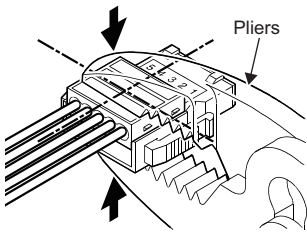

■Side view

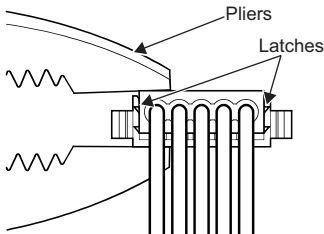

[Correct crimping]

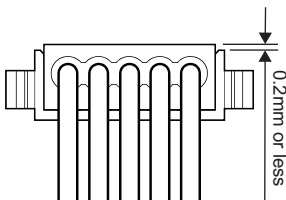

[Incorrect crimping]

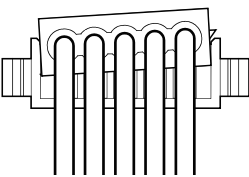

[Correct crimping]

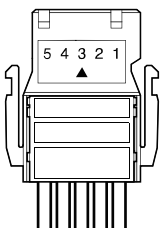

[Incorrect crimping]

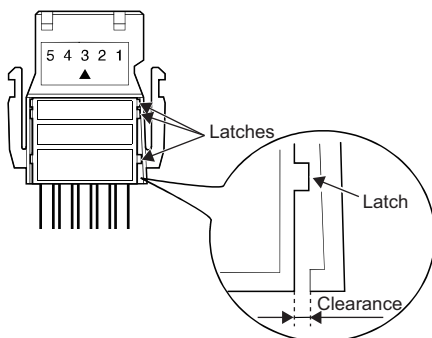

4. Crimping

Hold the center of plug cover with pliers and squeeze the cover in.

Fully push in the both edges (parts holding latches) of the plug cover. Check that the latches are engaged with the plug body.

5. Checking the crimped state (from the wire side)

Check that the plug body and plug cover are aligned horizontally seen from the wire side.

The lifted part of the plug cover must be 0.2mm or less.

As shown in the incorrect crimping, if the plug cover is lifted aslant or protruded from the plug body by more than 0.2mm, it may result in improper crimping.

Push in the plug cover correctly and fully with pliers as shown in the correct crimping.

6. Checking the crimped state (from the above)

Check that there is no clearance between the plug body and plug cover seen from the above.

As shown in the incorrect crimping, latches engaged improperly cause clearance between the plug body and plug cover.

Push in the plug cover correctly and fully with pliers as shown in the correct crimping.

Point 

When using a cabtyre cable, strip the jacket of the cable by 2cm or more. If the wires are uneven in length, cut the ends of the wires to an even length with a tool, such as a nipper, before inserting them to the connector.

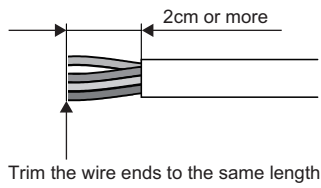

Precautions

When modules are transition wired through connectors for module power supply and FG, a current flows in the modules. When applying transition wiring, design the system so that the current that flows in the modules is equal to or lower than the allowable current value of each module.

6.7 Wiring the I/O Module (Waterproof Module) to the Power Supply

For the wiring, connect the power supply to the POWER IN terminal of the power supply connector of the I/O module (waterproof module).

Transition wiring of the power supply

When installing multiple I/O modules (waterproof module), the power can be supplied to the modules through transition wiring. For transition wiring, connect cables between the POWER OUT terminal of the module (power supplier) and the POWER IN terminal of another module (power supply destination).

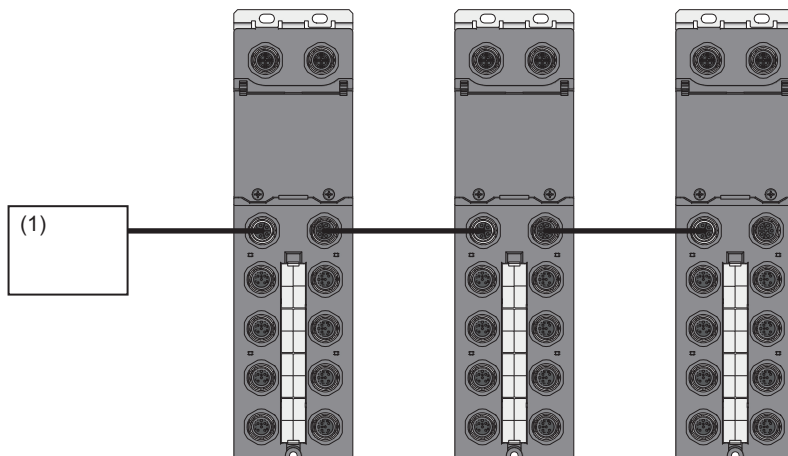

(1) Power supply

Point

For transition wiring, check the current consumption of each wired I/O module (waterproof module). For the current consumption of the modules, refer to the following performance specifications.

☞ Page 21 Input module, Page 46 Output module, Page 79 I/O combined module

Precautions

The largest current flows from the power supply to the power supply connector of the first I/O module (waterproof module). Make sure that the current does not exceed the following current capacity of the power supply connector.

- Module-and-sensor power supply: 8A per pin
- Load power supply and external power supply for output part: 12A per pin

For a power supply to supply 24VDC, use a power supply (SELV power supply) that does not exceed 30VAC (effective value), 42.4V (peak value), or 60VDC. Also, use a power supply which is applied to "limited-energy circuit" defined in IEC 61010-1.

6.8 Wiring of Ethernet Cable

Connecting the Ethernet cable to the I/O module (except for waterproof module)

■Connecting

1. Power off the module power supply of the I/O module (except for waterproof module) and the power of the external device.
2. Push the Ethernet cable connector into the I/O module (except for waterproof module) until it clicks. Pay attention to the connector's orientation.
3. Power on the module power supply of the I/O module (except for waterproof module).
4. Power on the external device.
5. Check if P1 LINK LED/P2 LINK LED on the port into which the Ethernet cable is connected is on.*1

*1 The time taken for P1 LINK LED/P2 LINK LED to turn on after connection of the Ethernet cable may vary. The LINK LED normally turns on in a few second. However, if link-up processing is repeated due to a condition of a device on the line, the longer time may be required. If P1 LINK LED/P2 LINK LED does not turn on, refer to the following and take a corrective action.

☞ Page 189 When the P1 LINK LED or P2 LINK LED turns off

Point

- To use only one of them for star topology, either P1 or P2 can be connected.
- To use both of them for line topology and ring topology, P1-P1, P2-P2, and P1-P2 connections are possible.

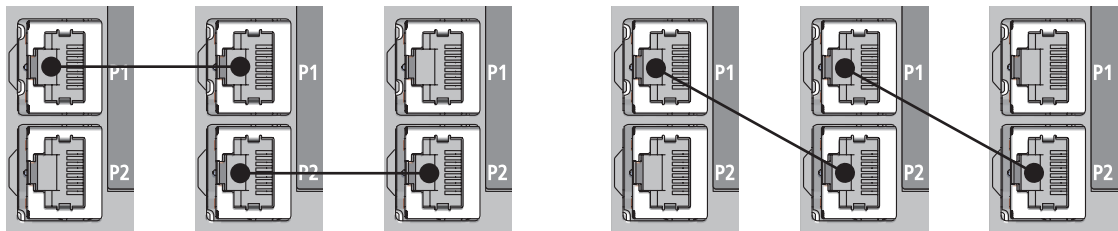

- For how to connect Ethernet cables for using the fast link-up function, refer to the following.

☞ Page 163 Fast Link-Up Function

■Disconnecting

1. Power off the module power supply of the I/O module (except for waterproof module).
2. Press the latch down and unplug the Ethernet cable.

Connecting the Ethernet cable to the I/O module (waterproof module)

■Connecting

1. Power off the module power supply of the I/O module (waterproof module) and the power of the external device.
2. Insert the Ethernet cable connector into the I/O module (waterproof module). Pay attention to the connector's orientation.
3. Tighten the Ethernet cable connector.
4. Power on the module power supply of the I/O module (waterproof module).
5. Power on the external device.
6. Check if P1 LINK LED/P2 LINK LED on the port into which the Ethernet cable is connected is on. ^{*1}

If P1 LINK LED/P2 LINK LED does not turn on, refer to the following and take a corrective action.

☞ Page 189 When the P1 LINK LED or P2 LINK LED turns off

^{*1} The time taken for P1 LINK LED/P2 LINK LED to turn on after connection of the Ethernet cable may vary. The LINK LED normally turns on in a few second. However, if link-up processing is repeated due to a condition of a device on the line, the longer time may be required.

Point

Both P1 and P2 connectors can be used.

- To use only one of them for star topology, either P1 or P2 can be connected.
- To use both of them for line topology and ring topology, P1-P1, P2-P2, and P1-P2 connections are possible.

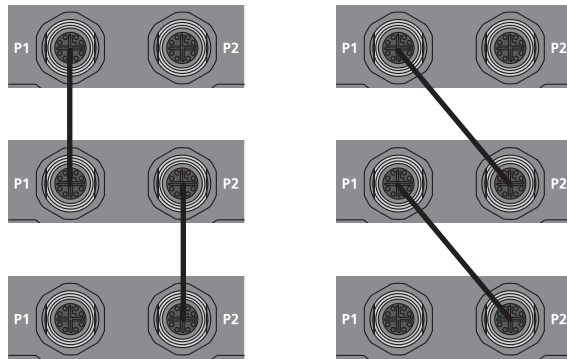

■Disconnecting

1. Power off the module power supply of the I/O module (waterproof module).
2. Loosen the Ethernet cable connector and remove the cable.

Precautions

■Laying Ethernet cables

- Place the Ethernet cable in a duct or clamp them. If not, dangling cable may swing or inadvertently be pulled, resulting in damage to the I/O module or cables or malfunction due to poor contact.
- Do not touch the core of the connector of the cable or the module, and protect it from dirt and dust. If any oil from your hand, or any dirt or dust sticks to the core, it can increase transmission loss, causing data link to fail.
- For the Ethernet cables to be used, check that they are not disconnected or short-circuited and that there is no problem with connector connection.

■Broken cable latch

Do not use Ethernet cables with broken latches. Doing so may cause the cable to unplug or malfunction.

■Connecting and disconnecting the Ethernet cable

Hold the connector part when connecting and disconnecting the Ethernet cable. Pulling the cable connected to the I/O module may result in damage to the I/O module or cable or malfunction due to poor contact.

■Connectors without Ethernet cable

Attach connector covers or waterproof caps to prevent dirt and dust from entering the I/O module and prevent I/O module failure and malfunction caused by static electricity.

■Maximum segment length for the Ethernet cable (Maximum cable length)

The maximum segment length for the Ethernet cable is 100m. However, the distance may be shorter depending on the operating environment of the cable. For details, contact the manufacturer of the cables used.

■Bending radius of the Ethernet cable

There are restrictions on the bending radius of the Ethernet cable. Check the bending radius in the specifications of the Ethernet cables used.

6.9 Wiring of I/O Module and External Device

Wiring of spring clamp terminal block

Wire to be used

The following table describes the wire to be connected to the spring clamp terminal block.

Diameter	Type	Material	Temperature rating
22 to 16 AWG	Stranded	Copper	75°C or more

Applicable solderless terminal

The following table lists the applicable solderless terminal.

Product name	Terminal shape	Model	Applicable wire size* ¹	Bar solderless terminal tool	Contact
Bar solderless terminal	Ferrule (with insulation sleeve)	A10.34-10TQ	0.34mm ²	CRIMPFOX6	PHOENIX CONTACT GmbH & Co. KG
		A10.5-10WH	0.5mm ²		
		A10.75-10GY	0.75mm ²		
	Ferrule (without insulation sleeve)	A0.5-10	0.5mm ²		
		A0.75-10	0.75mm ²		
		A1.0-10	1.0mm ²		
		A1.5-10	1.5mm ²		

*1 When using a solderless terminal with an insulation sleeve, select the terminal whose applicable wire size is 0.75mm² or smaller.

Installing or removing the terminal block

The following procedures show how to install and remove the terminal block.

■ Lock and release lever positions

To make it easy to install and remove the terminal block, a three-stage positioning stopper is attached so that the lever does not freely turn around.

When installing or removing the terminal block, turn the lever to the lock or release lever position.

View of right side of I/O module: When pulling out the terminal block

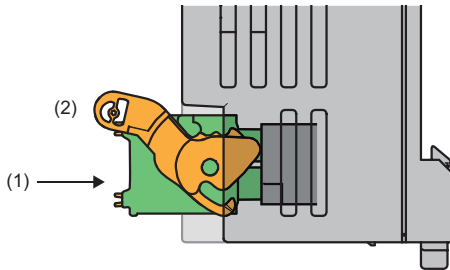

1. Release lever position

This lever position shows the state in which the terminal block (1) has been completely pulled out from the I/O module. Turn from the locking lever position to the release lever position (2) and lift the terminal block from the I/O module.

View of right side of I/O module: When insertion of the terminal block is complete

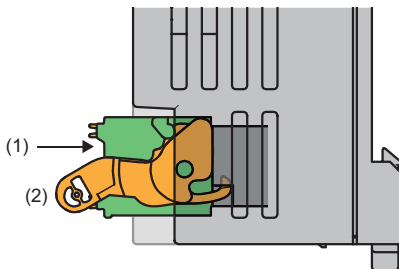

2. Lock lever position

This position shows the state in which the terminal block (1) completely fits the I/O module. Check the lock lever position (2) and pull the terminal block lightly to check that the I/O module completely fits the terminal block.

■ Removal procedure

Turn the lever to the release lever position and remove the terminal block from the I/O module.

■ Installation procedure

Move the lever to the locking lever position and push the terminal block. If the terminal block is fully pushed in, the hook of the lever hangs on the I/O module and fits the terminal block.

Point

The terminal block can be inserted with the lever locations other than the lock lever position. After insertion, check that the lever is in the lock lever position.

Signal name and wiring

For the signal names of the terminal block and wiring of the external device, refer to the specifications of each module. (Page 21 Performance Specifications)

Incorrect wiring can cause malfunction of or damage on the I/O module.

Connecting and disconnecting the cable

■Connecting the cable

Strip the cable as follows.

- The strip length of wire: 10mm

Insert a wire whose tip was processed into a wire insertion opening (2) and push it all the way in to the back.

If the wire cannot be inserted by this method, insert the wire all the way in to the back while pressing the release button (1) using a flathead screwdriver with a tip width of 2.0 to 2.5mm. Once the wire is inserted all the way in to the back, remove the flathead screwdriver.

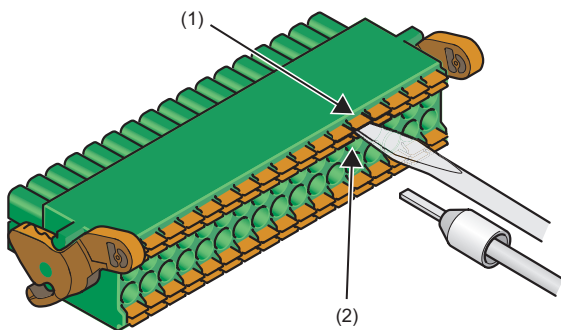

Point

Pull the wire or bar solderless terminal lightly to check that it is securely clamped.

■Disconnecting the cable

Pull the wire while pressing the release button using a flathead screwdriver with a tip width of 2.0 to 2.5mm.

Precautions

- Use bar solderless terminals for wiring to the terminal block. If a stripped wire is inserted into a wire insertion opening as-is, the wire cannot be securely clamped.
- Use a crimping tool to connect a bar solderless terminal to a wire. (☞ Page 134 Applicable solderless terminal)
- When inserting a bar solderless terminal, check that the size of the terminal and its insertion direction are correct to prevent the terminal from getting stuck in or the terminal block damage. When using a bar solderless terminal other than the applicable solderless terminals, check that for its size, the cross-sectional shape of the terminal after processing (1) is smaller than the size mentioned below, even including an error in processing. For the correct terminal insertion direction, refer to the figure below.

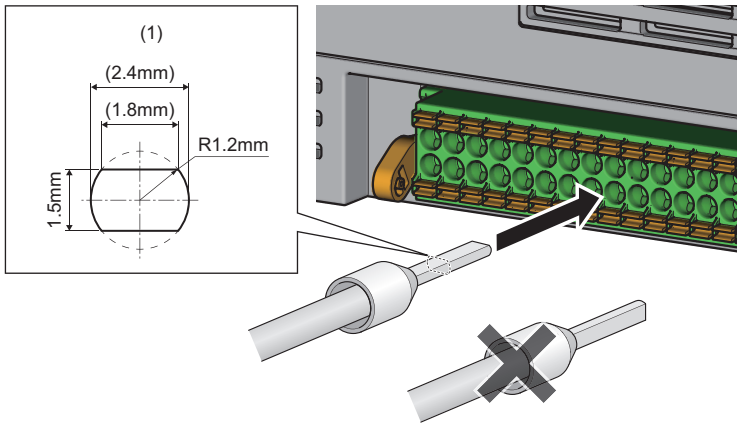

Point

For details on the finish shape of a bar solderless terminal including an error in processing, contact the manufacturers of the bar solderless terminal and the bar solderless terminal tool.

Wiring of screw terminal block

Tightening torque

Tighten the terminal screw within the following tightening torque range.

Tightening the screws too much may damage the I/O module case.

Screw type	Tightening torque range
Terminal screw (M3 × 5.2 screw)	0.43 to 0.57N·m
Terminal block mounting screw (M3.5 screw)	0.68 to 0.92N·m

Wire to be used

The following table describes the wire to be connected to the screw terminal block.

Diameter	Type	Material	Temperature rating
22 to 14 AWG	Stranded	Copper	75°C or more

Applicable solderless terminal

The following table lists the applicable solderless terminal.

Model	Applicable wire size	Contact
RAA1.25-3	0.3 to 1.25mm ²	—
V2-MS3	1.25 to 2.0mm ²	J.S.T.MFG.CO.,LTD.
TGV2-3N	1.25 to 2.0mm ²	NICHIFU Co., Ltd.

Installing or removing the terminal block

■Removal procedure

When the terminal block mounting screws (two points) are loosened, the two-piece terminal block can be removed.

■Installation procedure

1. Install the two piece terminal block.
2. Tighten the terminal block mounting screws.

Signal name and wiring

For the signal names of the terminal block and wiring of the external device, refer to the specifications of each module. ( Page 21 Performance Specifications)

Incorrect wiring can cause malfunction of or damage on the module.

Wiring method

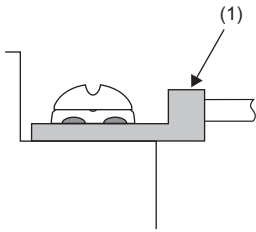

1. Loosen the terminal screw. Connect the round solderless terminal (1) as it is.

Point

- Do not put oil on the terminal and screw. Failure to do so may damage the screw.
- The number of the applicable solderless terminals must be two or less. When inserting two applicable solderless terminals, insert them back-to-back. Otherwise the screw cannot be tightened and it may damage the screw.
- Tighten the terminal screw with an applicable driver. Tightening with an inapplicable driver may damage the screw.
- When operating terminal screws in the lower row, prevent the screwdriver from contacting the upper row. If the screwdriver contacts the upper row, it may damage the terminal block.
- Install the terminal block so it is level. If the terminal block skews when installed, it may damage the contacts of the terminal block.

Wiring of 40-pin connector

Tightening torque

Tighten the connector screws within the following tightening torque range.

Undertightening can cause short circuit, fire, or malfunction. Overtightening can damage the screw and/or module, resulting in drop, short circuit, fire, or malfunction.

Screw type	Tightening torque range
Connector screw (M2.6 screw)	0.20 to 0.29N·m

Applicable connector

The following tables list the types of 40-pin connectors and reference products of crimping tools and pressure-displacement tools.

■40-pin connector

Type	Model	Applicable wire size
Soldering type connector (straight type)	A6CON1 ^{*1}	0.08 to 0.3mm ² (28 to 22 AWG), (stranded wire)
Crimping type connector (straight type)	A6CON2	0.08 to 0.24mm ² (28 to 24 AWG), (stranded wire)
IDC type connector (straight type)	A6CON3	0.08mm ² (28 AWG) (stranded wire) φ0.25mm (30 AWG) (solid wire) Flat cable (intervals of 1.27mm)
Soldering type connector (dual purpose (straight/oblique) type)	A6CON4 ^{*1}	0.08 to 0.3mm ² (28 to 22 AWG), (stranded wire)

*1 When using 40 pins, use cables whose sheath outside diameters are 1.3mm or shorter. Select cables according to the amount of current to flow.

■40-pin connector crimping tool and pressure-displacement tool

Type	Model	Contact
Crimping tool	FCN-363T-T005/H	FUJITSU COMPONENT LIMITED
Pressure-displacement tool	FCN-367T-T012/H (locator plate)	
	FCN-707T-T001/H (cable cutter)	
	FCN-707T-T101/H (hand press)	

For how to wire the connectors and how to use the crimping tool and pressure-displacement tools, contact FUJITSU COMPONENT LIMITED.

Signal name and wiring

For the signal names of the terminal block and wiring of the external device, refer to the specifications of each module. (Page 21 Performance Specifications)

Incorrect wiring can cause malfunction of or damage on the module.

Wiring method

■For A6CON1 and A6CON4

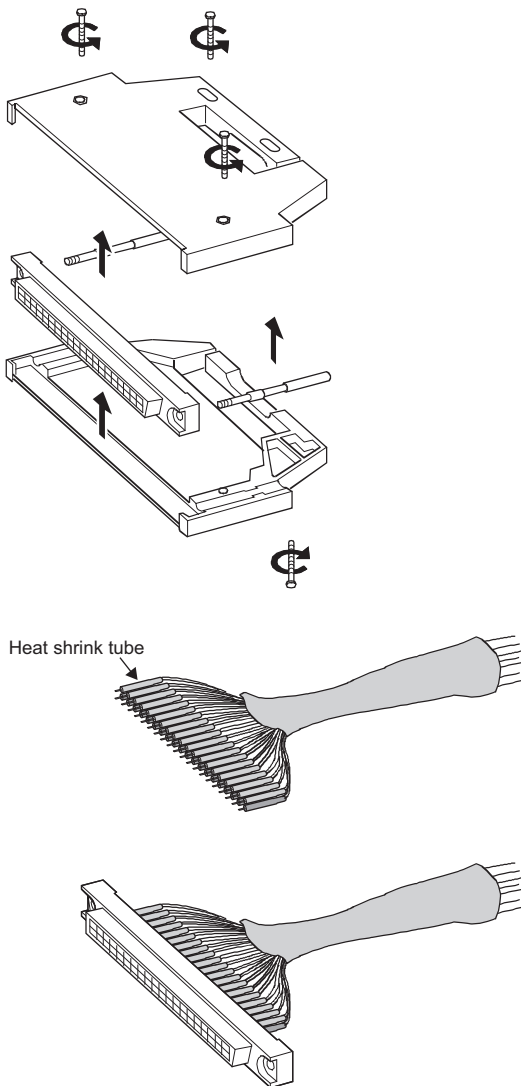

1. Loosen four screws of the connector and remove the screws.

2. Remove the covers from the body.

3. Solder the wires and cover the wires with heat shrinkable tubes.

4. Check the terminal layout and connect the wires to the connector body.

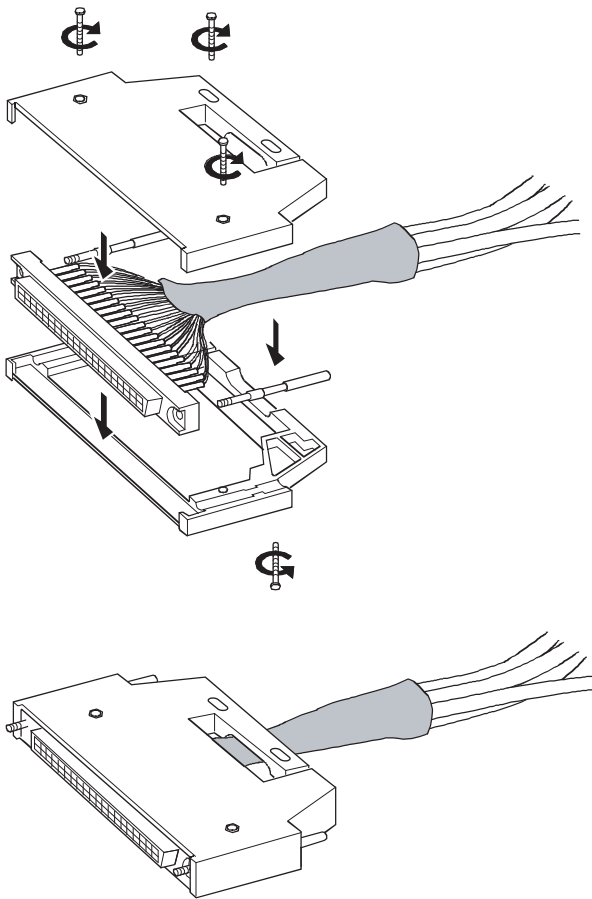

5. Place the body in one of the cover and insert the fixing screws into the screw holes. After that, fit the other cover on the body.
6. Tighten the four screws.

■For A6CON2

The following table shows the specifications of the FCN-363T-T005/H to be used for the A6CON2.

Applicable wire size	Cross-section area of the wire	Crimp height	Sheath outside diameter	Stripping length
24 AWG	0.20 to 0.24mm ²	1.25 to 1.30	φ1.2 or less	3.0 to 4.0
26 AWG	0.13 to 0.16mm ²	1.20 to 1.25	φ1.2 or less	3.0 to 4.0
28 AWG	0.08 to 0.096mm ²	1.15 to 1.20	φ1.2 or less	3.0 to 4.0

For wiring of the A6CON2, a special tool is required.

For how to use or adjust the tool, contact FUJITSU COMPONENT LIMITED.

■For A6CON3

For wiring of the A6CON3, special tools are required.

For how to use or adjust the tools, contact FUJITSU COMPONENT LIMITED.

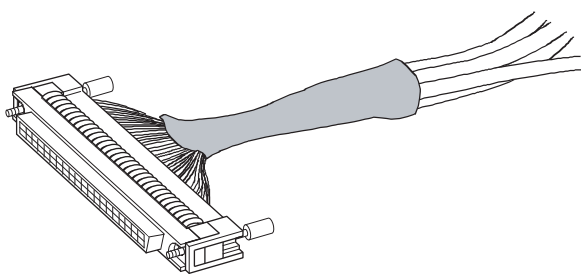

1. Check the terminal layout and crimp the wires to the connector.

Point

The following figure shows the array of terminals for flat cables. (a view from the outlet of a 40-pin connector)

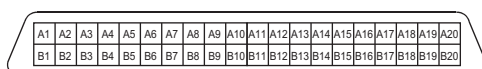

Installation procedure

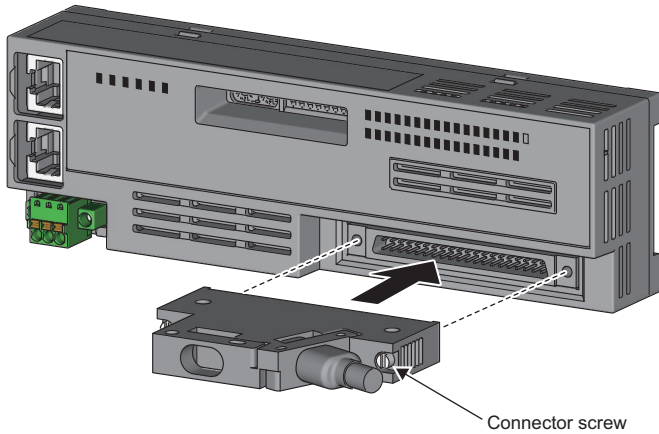

- 1.** Connecting a connector
Connect the wired connector to the I/O module.

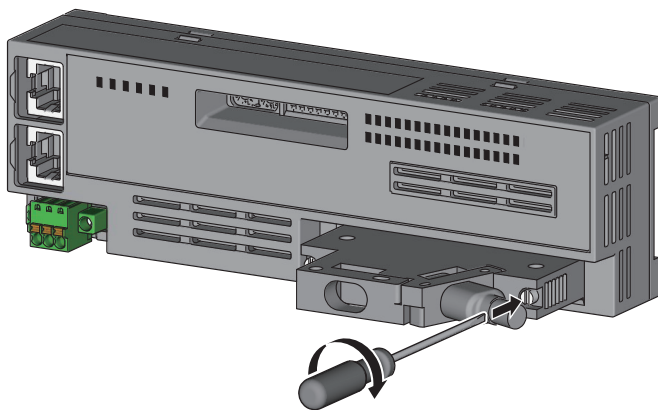

- 2.** Tightening connector screws
Tighten two connector screws (M2.6 screw).

6

Removal procedure

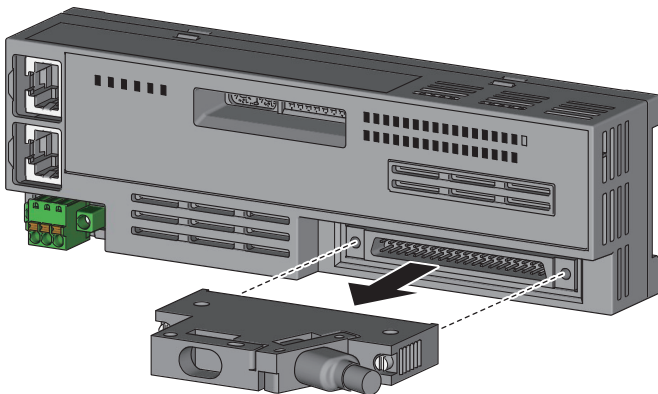

- 1.** Removing a connector
Loosen two connector screws and pull out the connector horizontally from the module.

Precautions

■Laying cables

- To connect the cables to the I/O module, securely connect the connector and fix it with screws at two points.
- Place the cables in a duct or clamp them. If not, a dangling cable may swing or inadvertently be pulled, resulting in damage to the module or cables or malfunction due to poor contact.

■40-pin connector

- 40-pin connectors (A6CON□) must be crimped or pressed with tools specified by the manufacturer, or must be correctly soldered. Incomplete connections may cause short circuit, fire, or malfunction.
- For wires to be connected to 40-pin connectors (A6CON□), use copper wires with the temperature rating of 75°C or more.

Point

To ensure that this product complies with the EMC Directive and the Low Voltage Directive, refer to the following.

 Page 243 EMC and Low Voltage Directives

Even though the compliance with the EMC Directive and the Low Voltage Directive is not required, configuring a system that complies with the EMC Directive may reduce effects of the external noise.

Wiring of sensor connector (e-CON)

Applicable connector

The following table lists reference products of sensor connectors (e-CON).

Model	Manufacturer	Specifications			Color of the cover
		Applicable cable (core wire size)	Applicable cable (outer diameter)	Maximum rated current	
ECN-M014R	Mitsubishi Electric System & Service Co., Ltd.	0.14 to 0.30mm ² (26 to 24 AWG)	φ0.8 to 1.0mm	2.0A	Red
ECN-M024Y			φ1.0 to 1.2mm		Yellow
ECN-M034OR			φ1.2 to 1.6mm		Orange
ECN-M044GN		0.30 to 0.50mm ² (22 to 20 AWG)	φ1.0 to 1.2mm		Green
ECN-M054BL			φ1.2 to 1.6mm		Blue
ECN-M064GY			φ1.6 to 2.0mm		Blue
					Gray

Signal name and wiring

For the signal names of the terminal block and wiring of the external device, refer to the specifications of each module. ( Page 21 Performance Specifications)

Incorrect wiring can cause malfunction of or damage on the module.

Wiring method

For how to wire the sensor connectors (e-CON), refer to the catalogs of each manufacturer.

Wiring of waterproof connectors

Applicable connectors and cables

For connectors and cables that can be used for the I/O module (waterproof module), refer to the following.

 Page 147 List of Recommended Cables/Connectors for the I/O Module (Waterproof Module)

Signal names and wiring

For the signal names of the connectors and wiring of the external device, refer to the specifications of each module. ()

Page 21 Performance Specifications)

Incorrect wiring can cause malfunction of or damage on the module.

Connecting

1. Insert the I/O cable connector into the I/O module (waterproof module). Pay attention to the connector's orientation.
2. Tighten the I/O cable connector.

Disconnecting

1. Loosen the I/O cable connector and remove the cable.

Point

If the I/O cable is damp, the connector's resin part of the module may get wet from the moisture on the cable at its removal. Dry or wipe up the water from the resin part for re-connecting the I/O cable.

6.10 List of Recommended Cables/Connectors for the I/O Module (Waterproof Module)

The following tables list applicable waterproof cables/connectors.

For details on applicable waterproof connectors, refer to the website of each manufacturer.

For power supply

The waterproof cables are listed below.

□, □ of a model represents the length of the cable.

Connector		Model	Connection cable diameter	Manufacturer
M12 5 pins (4 + FE) Male, female	L code	SC-M12PWL5MF-□, □MU	—	Mitsubishi Electric System & Service Co., Ltd.
M12 5 pins (4 + FE) Female, discrete wire		SC-M12PWL5F-□, □MU		

For I/O

The waterproof connectors/cables are listed below.

□, □ of a model represents the length of the cable.

Connector		Model	Connection cable diameter	Manufacturer
M12 5 pins Male, discrete wire	A code	SC-M12SNA5M-□, □MU	—	Mitsubishi Electric System & Service Co., Ltd.
M12 4 pins Male, discrete wire		SC-M12SNA4M-□, □MU		
M12 5 pins Male, discrete wire (shielded)		SC-M12SNA5SM-□, □MU		
M12 4 pins Male, discrete wire (shielded)		SC-M12SNA4SM-□, □MU		
M12, A code	—	SACC-M12MS-5CON-PG 7-M	φ4.0 to 6.0mm	PHOENIX CONTACT GmbH & Co. KG
		SACC-M12MS-5CON-PG 9-M	φ6.0 to 8.0mm	

Y-branch connector for I/O

The waterproof connector is listed below.

Connector		Model	Connection cable diameter	Manufacturer
M12 5 pins Male	A code	SAC-5P-M12Y/2XM12FS VP	—	PHOENIX CONTACT GmbH & Co. KG

For communications

The waterproof connectors/cables are listed below.

□,□ of a model represents the length of the cable.

Connector		Model	Connection cable diameter	Manufacturer		
M12 8 pins Male	X code-X code	SC-E5EW-X□,□M	—	Mitsubishi Electric System & Service Co., Ltd.		
		SC-E5EW-X□,□M-MV				
		SC-E5EW-X□,□M-L				
M12 8 pins Male	X code-RJ45	SC-E5EW-SX□,□M				
		SC-E5EW-SX□,□M-MV				
		SC-E5EW-SX□,□M-L				
M12 8 pins Male	X code-X code	NBC-M12MSX/□, □-94F/M12MSX NBC-M12MSX-M12MSX-10G/94F/ □,□	—	PHOENIX CONTACT GmbH & Co. KG		
		M12 8 pins Male			X code-RJ45	NBC-M12MSX/□, □-94F/R4AC NBC-M12MSX-R4AC-10G/94F/□,□
M12 8 pins Male, X code	—					J80026A0100
— (cable only)		SC-E5EW-□,□M			—	Mitsubishi Electric System & Service Co., Ltd.

Waterproof caps

The waterproof caps are listed below.

Type	Model	Manufacturer
I/O connector, communication connector	PROT-M12	PHOENIX CONTACT GmbH & Co. KG
	SC-M12SNCP-CAP	Mitsubishi Electric System & Service Co., Ltd.
Power supply connector (male)	PROT-M12 FS	PHOENIX CONTACT GmbH & Co. KG
	SC-M12SNCR-CAP	Mitsubishi Electric System & Service Co., Ltd.
Power supply connector (female)	PROT-M12 MS PWR	PHOENIX CONTACT GmbH & Co. KG
	SC-M12PWP-CAP	Mitsubishi Electric System & Service Co., Ltd.

6.11 Attaching Waterproof Caps

Tighten the waterproof caps within the following torque range.

Screw type	Tightening torque range
Waterproof cap	0.36 to 0.44N·m

7 PARAMETER SETTING

This chapter uses GX Works3 for explanations.

7.1 Network Configuration Setting

For the setting procedure for the master station, refer to the following.

 User's manual for the master station used

Setting procedure

A profile is required for each of the model names of the modules to be used.

Operating procedure

1. Open the "CC IE Field Configuration" window.
2. Select the module in "Module List" and drag it to the list of stations or the network map.

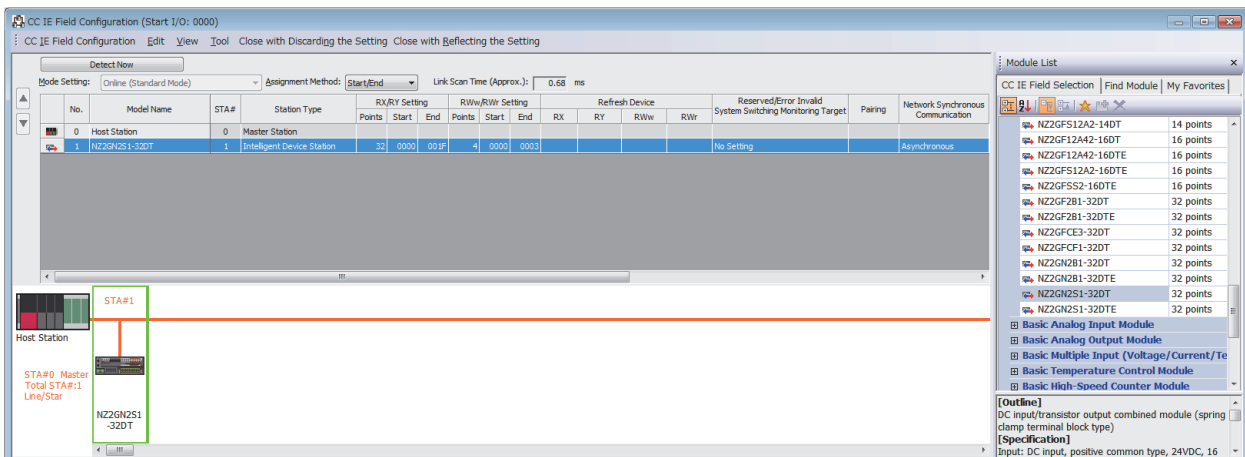

3. An assignment setting row is added to the station list, the total number of stations is increased, and the selected module is added to the network map.
4. Set items in the station list if necessary.
5. Click the [Close with Reflecting the Setting] button to complete the setting process and close the window.

Point

- The setting operation can be performed with a general-purpose profile. In that case, select "General Intelligent Device Station" or "General Remote Station" from the "Module List", and then drag and drop it to the station list or the network map.
- A module can also be added to the station list by copying and pasting the model name. In addition, multiple modules can be selected by dragging over model names and copied and pasted collectively. However, since the same value is pasted for the station numbers, the station numbers must be changed to avoid duplication.

Setting item list

Item		Description	Setting range
Station number		Set the station number of the I/O module.	1 to 120
RX/Ry setting	Points	Set the assignment of RX/Ry points in units of 16 points.	<ul style="list-style-type: none"> ■16-point module 16 to 128 (Default value: 16) ■32-point module 16 to 2048 (Default value: 32)
	Start	The RX/Ry start number is displayed.	—
	End	The RX/Ry end number is displayed.	—
RWw/RWr setting	Points	Set the assignment of RWw/RWr points in units of 4 points.	<ul style="list-style-type: none"> ■16-point module 4 to 64 (Default value: 4) ■32-point module 4 to 1024 (Default value: 4)
	Start	The RWw/RWr start number is displayed.	—
	End	The RWw/RWr end number is displayed.	—
Network Synchronous Communication		Set whether to use the network synchronous communication setting for the I/O module.	<ul style="list-style-type: none"> • Asynchronous (Default value) • Synchronous
Reserved/Error Invalid Station/System Switching Monitoring Target Station		Set this item when setting the I/O module as a reserved station or error invalid station.	<ul style="list-style-type: none"> • No setting (Default value) • Reserved • Error Invalid Station • System Switching Monitoring Target Station

8 FUNCTIONS

This chapter describes the details of the functions available in the I/O module, and the setting methods for those functions. For details on remote I/O signals and remote registers, refer to the following.

☞ Page 213 Remote I/O Signal

☞ Page 220 Remote Register

8.1 Input Response Time Setting Function

Prevents an incorrect input due to noise by setting the response time required for the module to recognize an actual input as the X signal.

Setting method

Set the input response time using function setting switch 2 to function setting switch 4 of the I/O module.

Function setting switch 2 to function setting switch 4			Input response time setting
Function setting switch 2	Function setting switch 3	Function setting switch 4	
Off	Off	Off	1ms ^{*1}
Off	Off	On	0ms
Off	On	Off	0.2ms
Off	On	On	1.5ms
On	Off	Off	5ms
On	Off	On	10ms ^{*2}
On	On	Off	20ms
On	On	On	70ms

*1 This is a value set to the I/O module (except for waterproof module) as a factory default.

*2 This is a value set to the I/O module (waterproof module) as a factory default.

The input response time setting is determined by the statuses of function setting switch 2 to function setting switch 4 at power-on.

If the setting of function setting switch 2 to function setting switch 4 is changed while the I/O module is powered on, one of the errors from Function setting switch 2 changed error (error code: 0202H) to Function setting switch 4 changed error (error code: 0204H) occurs, and the changed setting of the input response time is not applied.

The setting status of the input response time can be checked by Input response setting status (RWr2.b0 to RWr2.b2). For details, refer to the following.

☞ Page 228 Input response setting status (RWr2.b0 to RWr2.b2)

Precautions

Noise may be taken in as an input depending on the input response time setting.

The pulse width which is taken in as an input varies depending on the input response time.

To set the input response time, consider fully the operating environment.

The following table shows the minimum values of the pulse widths which may be taken in as an input. The pulse widths lower than the values shown below can be filtered as noise.

Value of input response time setting	0ms	0.2ms	1ms	1.5ms	5ms	10ms	20ms	70ms
The minimum value of the pulse width which may be taken in as an input (the maximum pulse widths which can be filtered as noise)	—	0.003ms	0.12ms	0.3ms	2ms	4ms	9ms	36ms

8.2 Output HOLD/CLEAR Setting Function

Sets whether to hold or clear the last output value when the I/O module is disconnected from data link, when the CPU module operating status is STOP, or when the CPU module operation is suspended by an error.

Output HOLD/CLEAR setting and its operation

When HOLD or CLEAR is set for an output, the output is turned on or off as follows.

Operating status		Output HOLD/CLEAR setting CLEAR		Output HOLD/CLEAR setting HOLD	
		Last output status OFF	Last output status ON	Last output status OFF	Last output status ON
Data link in operation	CPU module in RUN	Off	On	Off	On
	CPU module in STOP	Off	Off	Off	On
	CPU module in PAUSE	Off	On	Off	On
	CPU module in RESET	Off	Off	Off	On
	CPU module suspended by error	Off	Off	Off	On
During disconnection/cyclic stop		Off	Off	Off	On

If a moderate or major error has occurred in the I/O module, output turns off regardless of the output HOLD/CLEAR setting.

Setting method

Set HOLD or CLEAR using the function setting switch 5 of I/O module.

Function setting switch 5	Output HOLD/CLEAR setting
Off	CLEAR (Factory default)
On	HOLD

The setting of the output HOLD/CLEAR setting function is determined by the status of function setting switch 5 when the I/O module is powered on.

When the setting of function setting switch 5 is changed while the I/O module is on, a function setting switch 5 changed error (error code: 0205H) occurs, and the changed setting of the output HOLD/CLEAR setting function is not applied.

The setting status of the output HOLD/CLEAR setting can be checked by Output HOLD/CLEAR setting status (RWr2.b3). For details, refer to the following.



 Page 228 Output HOLD/CLEAR setting status (RWr2.b3)

8.3 CC-Link IE Field Network Synchronous Communication Function

I/O is performed with a synchronization cycle of the master station that supports the CC-Link IE Field Network synchronous communication function.

This enables the I/O module to operate at the same timing as other slave stations on the same network.

The CC-Link IE Field Network synchronous communication function of the I/O module has the following two modes.

- Synchronous X/Y control mode ( Page 155 Synchronous X/Y control mode)
- Synchronization cycle timing control mode ( Page 157 Synchronization cycle timing control mode)

Applicable master module

When using the CC-Link IE Field Network synchronous communication function, use one of the following products as the master module.

■MELSEC-Q/L series

Master module	Serial number (first five digits)
QD77GF16	"17102" or later
QD77GF8, QD77GF4	"17101" or later

■MELSEC iQ-R series

Master module	Firmware version
RJ71GF11-T2	"01" or later
RJ71EN71	
RnENCPU	
RD77GF32, RD77GF16, RD77GF8, RD77GF4	

To set the synchronization cycle in increments of 0.05ms, use one of the following products as the master module.

Master module	Firmware version
RJ71GF11-T2	"03" or later
RJ71EN71	
RnENCPU	
RD77GF32, RD77GF16, RD77GF8, RD77GF4	"01" or later



Synchronous X/Y control mode

Controls I/O by turning on and off the remote input signal and the remote output signal.

An I/O module operating in the synchronous X/Y control mode acquires an input signal at each synchronization cycle, and changes the output signal.

When the synchronous X/Y control mode is used, the input signal acquisition timing and the output signal change timing can be made to match between I/O modules.

The synchronous X/Y control mode has the following two types.

- Synchronous X input control ( Page 156 Synchronous X input control)
- Synchronous Y output control ( Page 156 Synchronous Y output control)

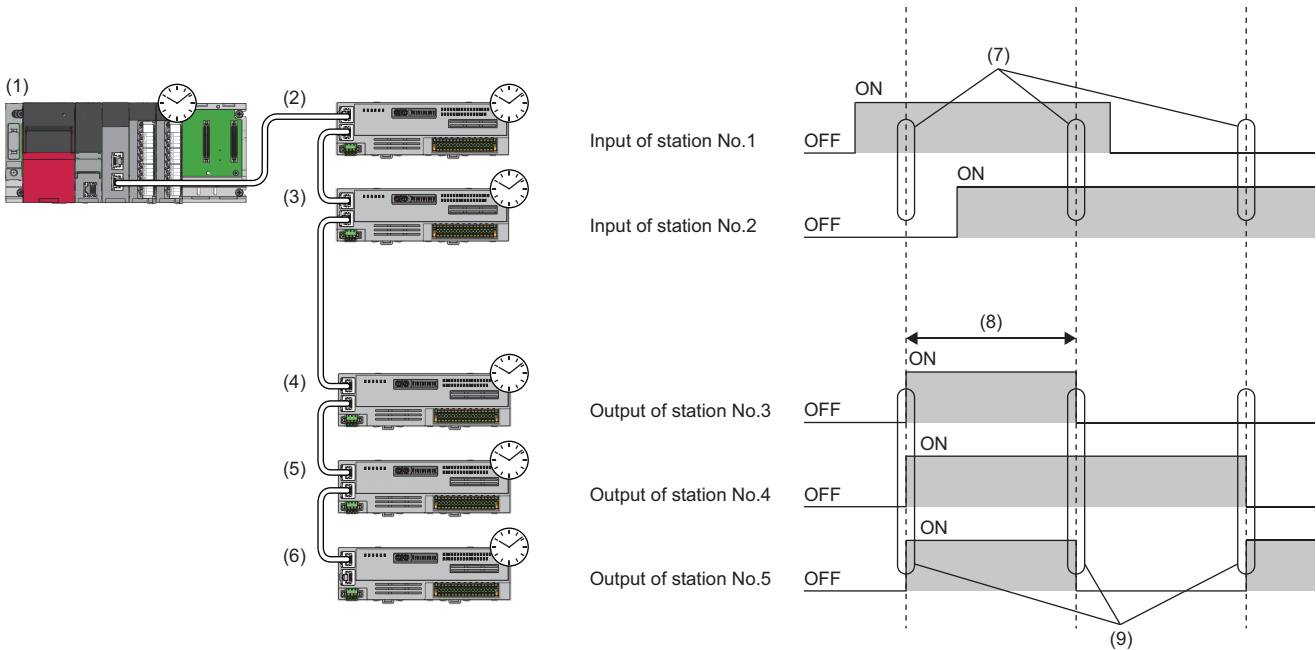

- (1) Master module
- (2) Station No.1 input module
- (3) Station No.2 input module
- (4) Station No.3 output module
- (5) Station No.4 output module
- (6) Station No.5 output module
- (7) Input loading timing synchronization
- (8) Synchronization cycle
- (9) Output change timing synchronization

Synchronous X input control

An I/O module operating with synchronous X input control reads out the status of External input X_n (X_n terminal) at each synchronization cycle.

The read value is also sent to the master station within the next synchronization cycle.

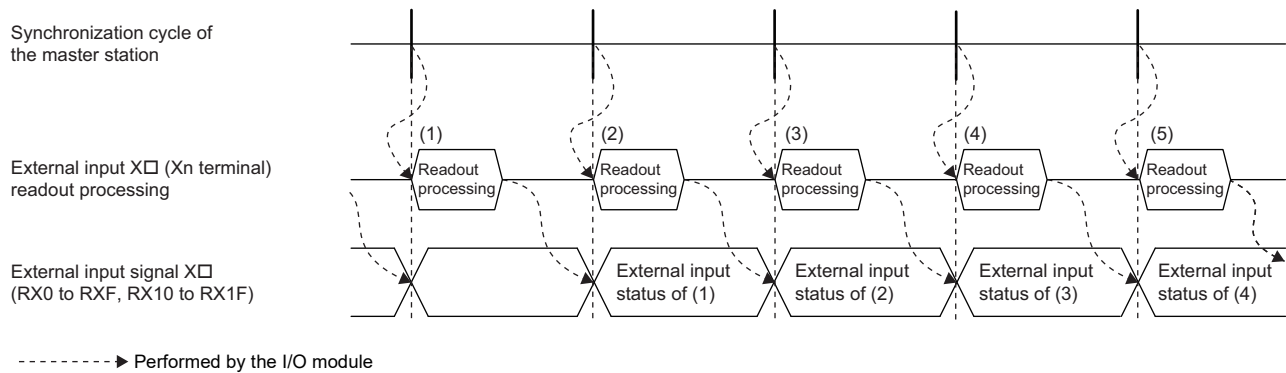

Synchronous Y output control

An I/O module operating with synchronous Y output control receives the external output value from the master station at each synchronization cycle, and outputs the received value in time with the next synchronization cycle.

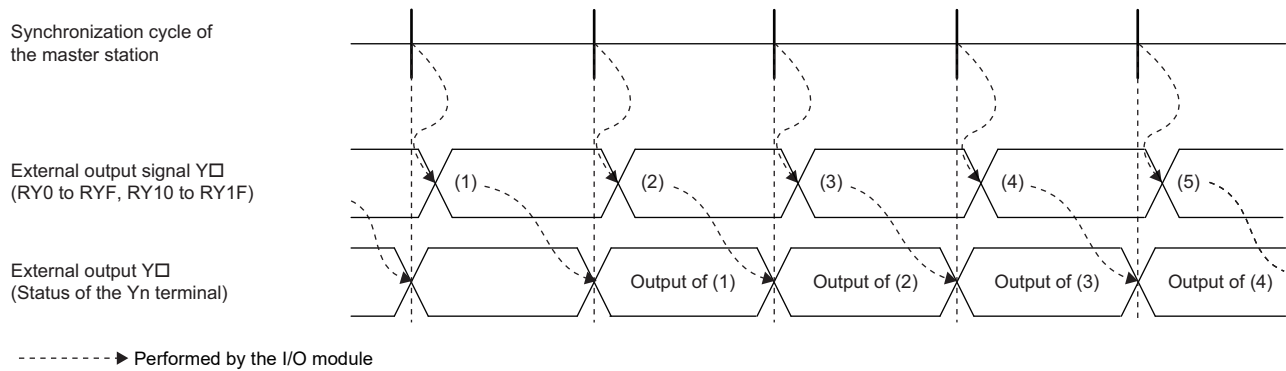

Synchronization cycle timing control mode

Controls I/O by using the time taken from a start of synchronization cycle to when the I/O has changed.

Compared to the I/O control performed every synchronization cycle, the I/O control using the synchronization cycle timing control mode has the higher resolution, enables a user to acquire the more precise time when an input signal has changed or to change an output signal at more precise timing.

The synchronization cycle timing control mode has the following two types.

- Synchronization input timing acquisition control (☞ Page 157 Synchronization input timing acquisition control)
- Synchronization output timing setting control (☞ Page 159 Synchronization output timing setting control)

Synchronization input timing acquisition control

A time when an input has changed can be acquired based on the synchronization cycle start timing.

- 1 The I/O module sends the following information to the master station at each synchronization cycle.
 - Synchronization input timing information X0 OFF to ON: Storing the time when the input has changed from off to on.
 - Synchronization input timing information X0 ON to OFF: Storing the time when the input has changed from on to off.
- 2 Synchronization input timing information X0 OFF to ON: 500 μ s, Synchronization input timing information X0 ON to OFF: No change of ON to OFF
- 3 Synchronization input timing information X0 OFF to ON: No change of OFF to ON, Synchronization input timing information X0 ON to OFF: 800 μ s
- 4 Synchronization input timing information X0 OFF to ON: No change of OFF to ON, Synchronization input timing information X0 ON to OFF: No change of ON to OFF

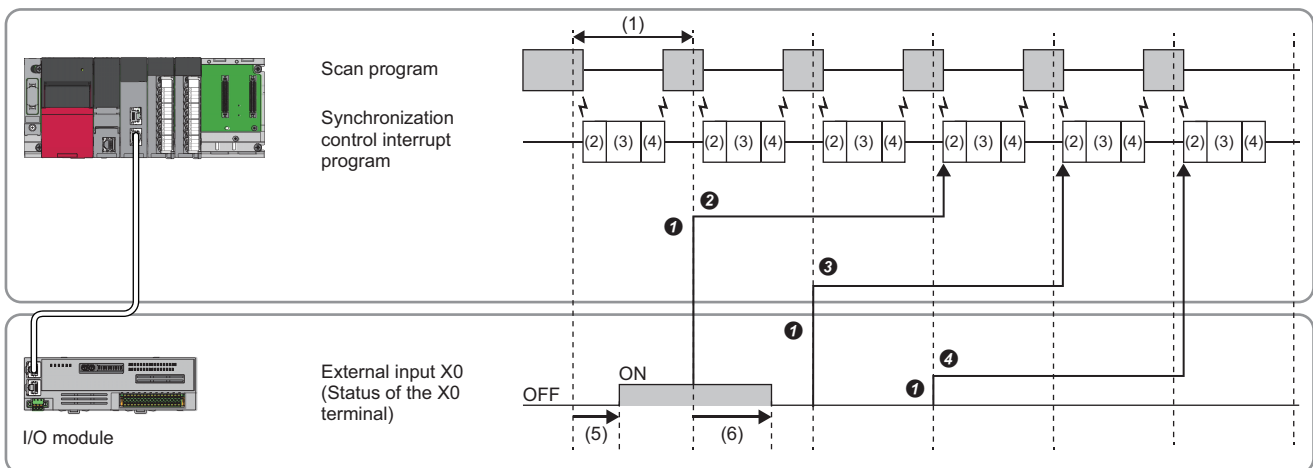

- (1) Synchronization cycle
- (2) Input
- (3) Operation
- (4) Output
- (5) The input has turned on 500 μ s later.
- (6) The input has turned off 800 μ s later.

■ Operation

Ex.

The following figure shows the operation of synchronization input timing acquisition control using the external input X0, with the synchronization cycle of the master station set to 3ms.

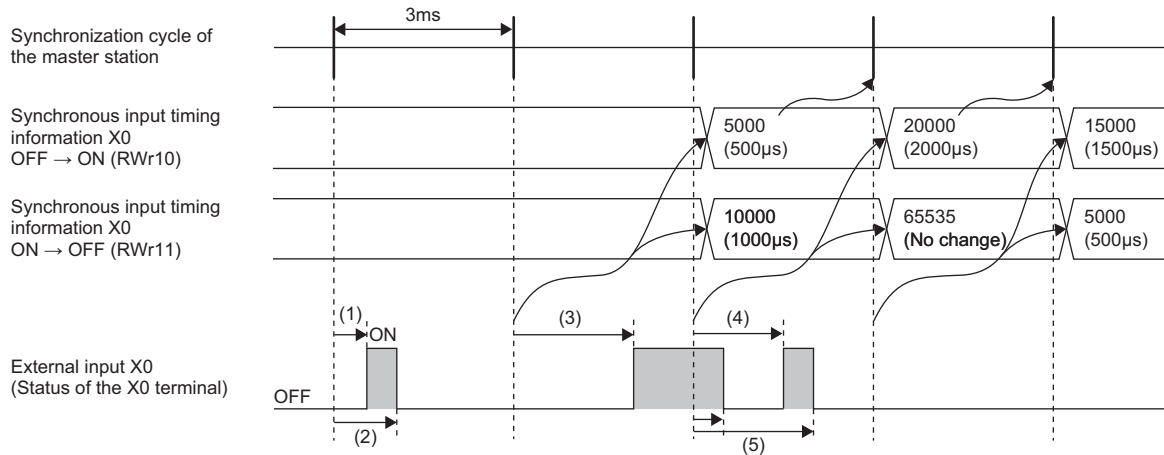

→ Performed by the I/O module

- (1) The input has turned on 500μs later.
- (2) The input has turned off 1000μs later.
- (3) The input has turned on 2000μs later.
- (4) The input has turned on 1500μs later.
- (5) The input has turned off twice, 500μs later and 2000μs later.

Point

- The operation of external input signal X□ is the same both for the synchronization input timing acquisition control and for the synchronous X input control. Therefore, even when the I/O module is operating with the synchronization input timing acquisition control, a user can get the input status information of each synchronization cycle start timing by referring to External input signal X□ (RX0 to RXF, RX10 to RX1F).
- When the external input X□ (status of the X□ terminal) has changed OFF to ON to OFF within one synchronization cycle, if the ON status is shorter than the input response time, a value in Synchronization input timing information X□ OFF to ON/ON to OFF (RWr10 to RWr4F) is not updated.
- When the external input X□ (status of the X□ terminal) has changed ON to OFF to ON within one synchronization cycle, if the OFF status is shorter than the input response time, a value in Synchronization input timing information X□ OFF to ON/ON to OFF (RWr10 to RWr4F) is not updated.
- The resolution of input timing acquisition is 0.1μs.
- If a major or moderate error occurs in the I/O module, 65535 is stored in Synchronization input timing information X□ OFF to ON/ON to OFF (RWr10 to RWr4F).

Synchronization output timing setting control

This control changes an output status according to the timing that is set based on the synchronization cycle start timing.

- ① Set the following for each synchronization cycle.
 - Synchronization output timing setting Y0 OFF to ON: Set the timing to change the output from off to on.
 - Synchronization output timing setting Y0 ON to OFF: Set the timing to change the output from on to off.
- ② Synchronization output timing setting Y0 OFF to ON: 200 μ s, Synchronization output timing setting Y0 ON to OFF: Do not change the output from on to off.
- ③ Synchronization output timing setting Y0 OFF to ON: Do not change the output from off to on, Synchronization output timing setting Y0 ON to OFF: 800 μ s
- ④ Synchronization output timing setting Y0 OFF to ON: Do not change the output from off to on, Synchronization output timing setting Y0 ON to OFF: Do not change the output from on to off.

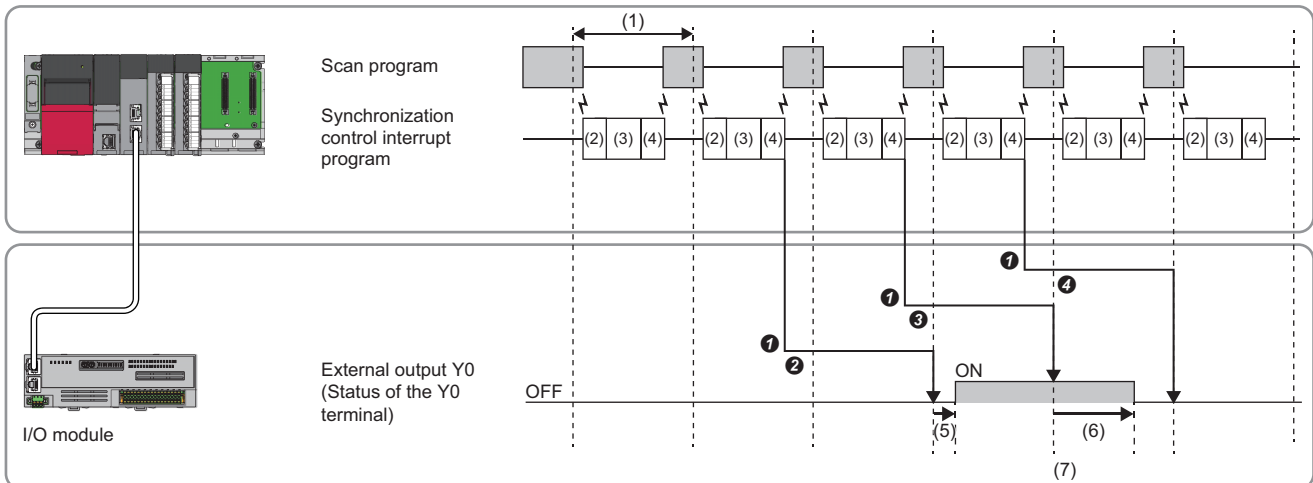

- (1) Synchronization cycle
- (2) Input
- (3) Operation
- (4) Output
- (5) The output has been turned on 200 μ s later.
- (6) The output has been turned off 800 μ s later.
- (7) The I/O module performs the output control according to the settings, at the second synchronization cycle from the setting.

■ Operation

Ex.

The following figure shows the operation of synchronization output timing setting control using the external output Y0, with the synchronization cycle of the master station set to 3ms.

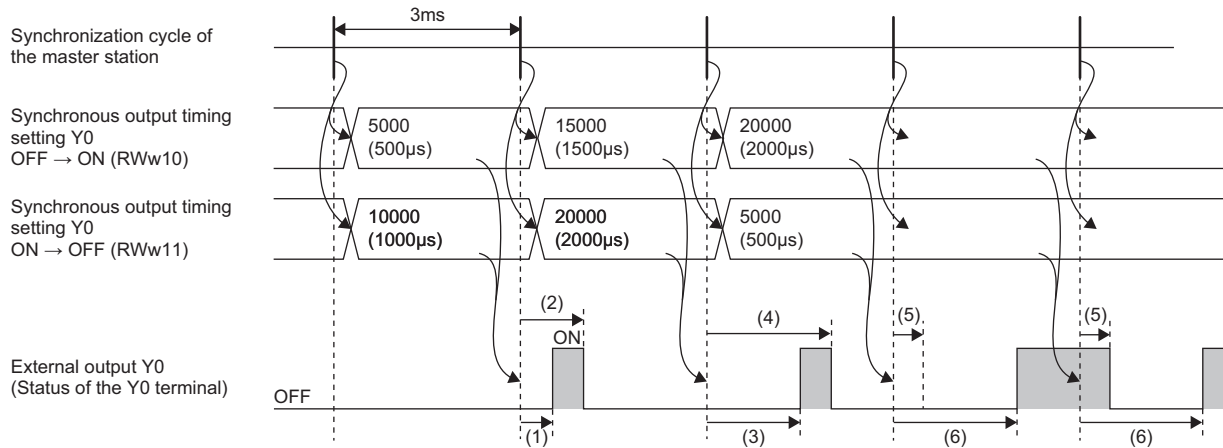

—————▶ Performed by the I/O module

- (1) The output has been turned on 500µs later.
- (2) The output has been turned off 1000µs later.
- (3) The output has been turned on 1500µs later.
- (4) The output has been turned off 2000µs later.
- (5) The output has been turned off 500µs later.
- (6) The output has been turned on 2000µs later.

Point

- When the I/O module operates with the synchronization output timing setting control, External output signal Y□ (RY0 to RYF, RY10 to RY1F) becomes invalid.
- A change of the external output Y□ (status of the Y□ terminal) is sent to the connected device with delay of the maximum output response time. Therefore, if the output is set to turn on or off at an interval shorter than the maximum output response time, the actual output may not turn on or off.
- The resolution of output timing setting control is 0.1µs.
- If the I/O module is disconnected from data link, the CPU module operating status is STOP, or the CPU module operation is suspended by an error, the output HOLD/CLEAR setting function is prioritized. Therefore, the actual external output may turn on or off differently from the way that is set in Synchronization output timing setting Y□ OFF to ON/ON to OFF. (☞ Page 153 Output HOLD/CLEAR Setting Function)

Setting method

Operation mode

Set the operation mode (synchronous X/Y control mode, synchronization cycle timing control mode) using the function setting switch 6 and the function setting switch 7 of the I/O module.

Function setting switch 6	Function setting switch 7	Operation mode
Off	Off	Synchronous X/Y control mode (factory default)
Off	On	Synchronization cycle timing control mode
On	Off	Use prohibited*1
On	On	Use prohibited*1

*1 If this combination is set, a MODE switch incorrect (error code: 0107H) occurs.

Setting the synchronization cycle (master station)

Set the synchronization cycle of the master station to any of the following:

- When the cycle is not set in increments of 0.05ms

Set the cycle to 0.88ms, 1.77ms, or 3.55ms.

- When the cycle is set in increments of 0.05ms

Set a value in the range 0.8ms to 10ms.

To use the CC-Link IE Field Network synchronous communication function for the I/O module, enable the CC-Link IE Field Network synchronous communication function of the master station.

For details on the setting method, refer to the manual for the master station in use.

Setting of CC-Link IE Field Network synchronous communication function

The CC-Link IE Field Network synchronous communication function of the I/O module is set with the network configuration setting.

Operating procedure

Before executing step 1 below, use function setting switch 6 and function setting switch 7 to set which operation mode to use (synchronous X/Y control mode, synchronization cycle timing control mode).

1. Open the "CC IE Field Configuration" window.

[Navigation window] ⇒ [Parameter] ⇒ [Module Information] ⇒ Model ⇒ [Basic Settings] ⇒ [Network Configuration Settings]

2. Set "Network Synchronous Communication" to "Synchronous".

3. In "RWw/RW_r Setting", set the address for "Start" and for "End".

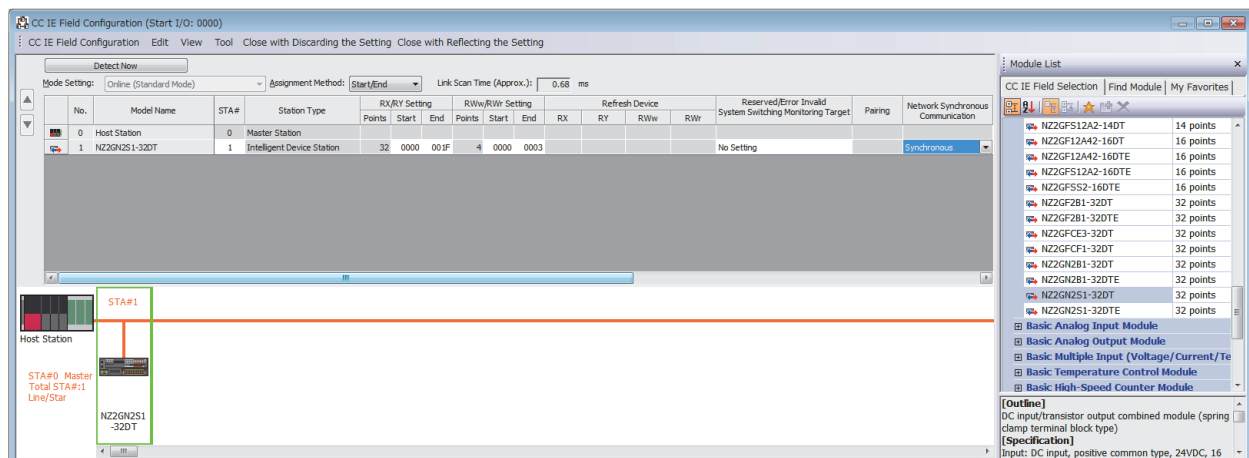

4. Click the [Close with Reflecting the Setting] button to close the CC IE Field Configuration window.

5. Click the [Apply] button.

6. After the power has been turned off and on or a remote reset has been performed, the I/O module starts operating in the synchronous communication mode.

Precautions

- The operating status of the CC-Link IE Field Network synchronous communication function can be checked by using the synchronous/asynchronous operation status information (each station) (SW01C8 to SW01CF) of the master station. For details, refer to the manual for the master station in use. When performing I/O control, provide interlock using the above link special register (SW). (☞ Page 172 CC-Link IE Field Network synchronous communication program)
- When the master station is a MELSEC-Q series Simple Motion module, always operate the I/O module with the CC-Link IE Field Network synchronous communication function enabled.
- The function can be used with the fast link-up function, but even when the fast link-up function is used, the time from data link establishment to synchronous communication start does not change.

Setting status

The setting status of the CC-Link IE Field Network synchronous communication function can be checked with the CC-Link IE Field Network synchronous communication setting status (RWr2.b4, RWr2.b5) of the remote register.

☞ Page 228 CC-Link IE Field Network synchronous communication setting status (RWr2.b4, RWr2.b5)

8.4 Fast Link-Up Function

This function shortens the time taken for data link establishment with the master station at power-on.

With this function, the time taken to change tools can be shortened in the system with a tool change mechanism (tool changer) for tools that attach to the end of an industrial robot arm.

The data link time varies depending on the number of connected modules or cable length. When eight I/O modules are connected (excluding the I/O module directly connected to the master module) and the station-to-station distance is 30m, data link is established in 0.5s on average.

☞ Page 178 Program Example for Using the Fast Link-Up Function

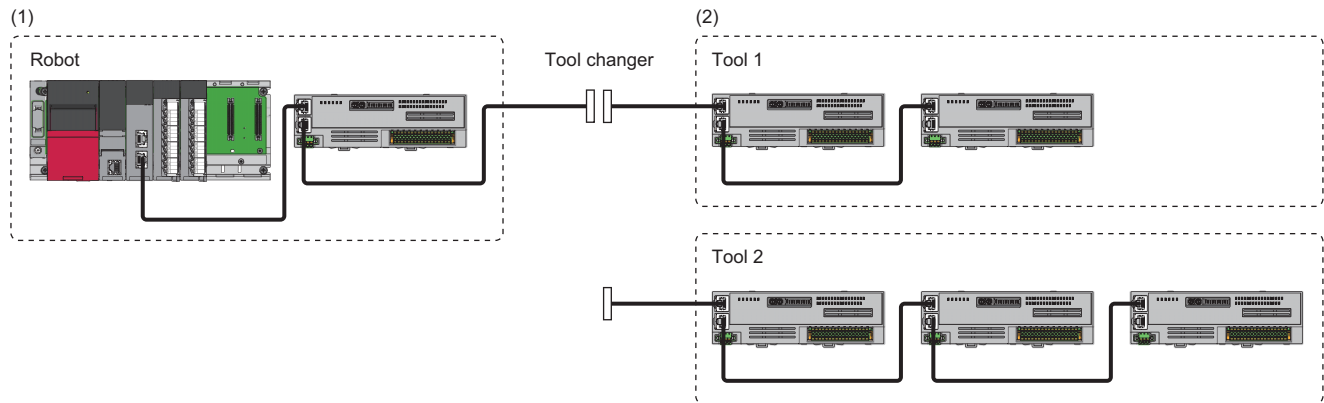

(1) System for the robot

(2) System implemented in the tool at the end of an arm

Applicable master module

To use the fast link-up function, use one of the following products as the master module.

■MELSEC-Q/L series

Master module	Serial number (first five digits)
QJ71GF11-T2	"18042" or later
LJ71GF11-T2	

■MELSEC iQ-R series

Master module	Firmware version
RJ71GF11-T2	"11" or later
RJ71EN71	
RnENCPU	

Setting method

Set the fast link-up function for each port.

Set whether to enable or disable the fast link-up function of P1 by using function setting switch 8 of the module, and the fast link-up function of P2 by using function setting switch 9 of the module.

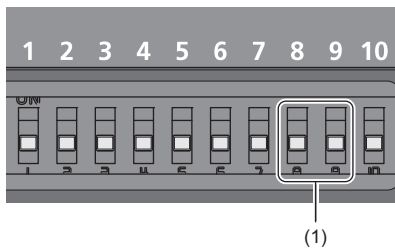

(1) Function setting switch 8 and function setting switch 9

Switch	State	Setting value
Function setting switch 8	On	Fast link-up function of P1: Enabled
	Off	Fast link-up function of P1: Disabled (factory default)
Function setting switch 9	On	Fast link-up function of P2: Enabled
	Off	Fast link-up function of P2: Disabled (factory default)

The status of whether this function is enabled or disabled is determined by the statuses of function setting switch 8 and function setting switch 9 at I/O module startup.

After the I/O module was started up, if the state of function setting switch 8 is changed, Function setting switch 8 changed error (error code: 0208H) occurs, and if the state of function setting switch 9 was changed, Function setting switch 9 changed error (error code: 0209H) occurs. The status of whether this function is enabled or disabled is not changed.

■Checking the status of the fast link-up function (enabled/disabled)

The current status of the fast link-up function (enabled/disabled) can be checked with Fast link-up setting status (PORT1) (RWr2.b6) and Fast link-up setting status (PORT2) (RWr2.b7).

☞ Page 228 Fast link-up setting status (PORT1) (RWr2.b6)

☞ Page 229 Fast link-up setting status (PORT2) (RWr2.b7)

How to use the fast link-up function

The following describes how to use the fast link-up function.

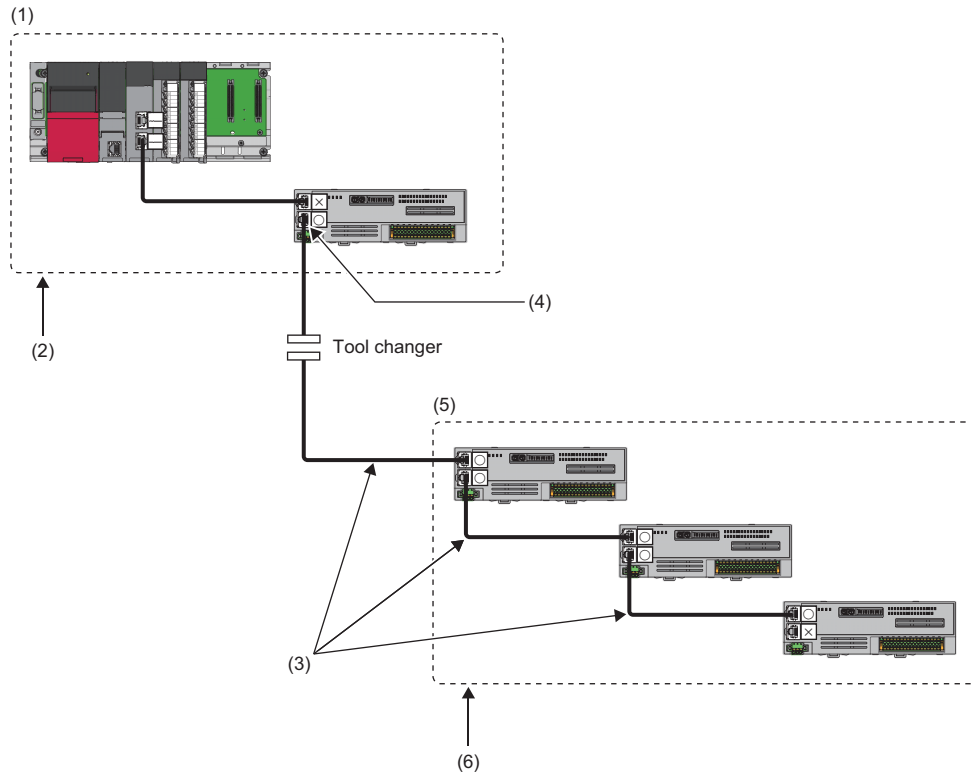

- : The fast link-up function is not supported.
- ×: The fast link-up function is disabled.
- : The fast link-up function is enabled.

No.	Description
(1)	In the robot-side system (The power is always on.)
(2)	Incorporate a master module and an I/O module in the robot-side system. Page 166 Incorporating a master module and an I/O module in the robot-side system The modules in the robot-side system are always on. Page 166 Keeping the modules in the robot-side system always powered on
(3)	Connect between ports where the fast link-up function is enabled. Page 166 Connecting between ports where the fast link-up function is enabled Connect P1 and P2. Page 166 Connect P1 and P2.
(4)	Enable the fast link-up function for P2 of the I/O module in the robot-side system, and connect to the tool-side system. Page 166 Enabling the fast link-up function for P2 of the I/O module in the robot-side system
(5)	In the tool-side system (The modules are powered on only while being connected.)
(6)	Simultaneously power on all of the I/O modules in the tool-side system. Page 166 Simultaneously powering on all of the I/O modules in the tool-side system Connect a tool in one second after the master station detects disconnection of a tool. Page 166 Connecting to a different tool in one second after the master station detects a disconnection of a tool previously used

Setting

■Connecting between ports where the fast link-up function is enabled

Enable the fast link-up function for both P1 and P2.

If a port where the fast link-up function is enabled is connected with a port where the fast link-up function is not supported or is disabled, link-up is not performed.

Installation and structure

■Incorporating a master module and an I/O module in the robot-side system

Incorporate a master module and an I/O module in the robot-side system.

Use one of the modules described below as the master module.

 Page 108 Applicable master station

Disable the fast link-up function for a port of the I/O module that is to be connected to the master module.

■Connect P1 and P2.

Between the modules where data link is established using the fast link-up function, connect P1 and P2 with cables.

Even if the fast link-up function is enabled, link-up will not be performed when P1 is connected to P1 or P2 is connected to P2.

■Enabling the fast link-up function for P2 of the I/O module in the robot-side system

Disable the fast link-up function for P1 of the I/O module in the robot-side system, and connect it with the master module.

Enable the fast link-up function for P2 of the I/O module in the robot-side system, and connect it with an I/O module in the tool-side system.

For any other connection, it may take longer time to establish data link.

Operation

■Keeping the modules in the robot-side system always powered on

Always keep the master module and I/O module in the robot-side system powered on during operation.

In the robot-side system, the master module is connected with the I/O module via a port where the fast link-up function is disabled, and thus the time taken to establish data link after power-on will not be shortened.

■Simultaneously powering on all of the I/O modules in the tool-side system

To connect using fast link-up, simultaneously power on all of the I/O modules in the tool-side system after switching a tool to a different one.

If the I/O modules are powered on at different times, it may take longer time to establish data link.

■Connecting to a different tool in one second after the master station detects a disconnection of a tool previously used

Connect to a tool (cable connection and power-on) in one second or longer after the master station detects a disconnection of a tool previously used.

If a tool is connected before a detection of a disconnection or within one second after the detection, it may take longer time to establish data link.

A disconnection can be detected by monitoring Data link status (each station) (SW00B0 to SW00B7) of the master station.

Precautions

- After the master station is powered on, it may take longer time to establish data link with each I/O module at the first connection.
- Depending on the operating environment, it may take longer time to establish data link.
- If the link scan time when no tool is connected is long, it may take longer time to establish data link.
- On the network configuration settings, set line topology for the network topology.

8.5 Output ON/OFF Information Hold Function

Checks whether the output has been turned on or off.

Output ON information

Output ON information is stored in Output Y ON information $Y□$ (RWrC, RWrD).

Whether the output has been turned on or not can be checked with Output Y ON information $Y□$ (RWrC, RWrD).

Output Y ON information $Y□$ (RWrC, RWrD) can be cleared using Output Y ON information clear request $Y□$ (RWwC, RWwD).

The amount of time delay from when Output Y ON information $Y□$ (RWrC, RWrD) changes until the external output accordingly changes is no more than the maximum output response time.

For the on and off timing, refer to the following.

☞ Page 230 Output Y ON information

Output OFF information

Output OFF information is stored in Output Y OFF information $Y□$ (RWrE, RWrF).

Whether the output has been turned off or not can be checked with Output Y OFF information $Y□$ (RWrE, RWrF).

Output Y OFF information $Y□$ (RWrE, RWrF) can be cleared using Output Y OFF information clear request $Y□$ (RWwE, RWwF).

The amount of time delay from when Output Y OFF information $Y□$ (RWrE, RWrF) changes until the external output accordingly changes is no more than the maximum output response time.

For the on and off timing, refer to the following.

☞ Page 231 Output Y OFF information

8.6 Protection Function

The transistor output module and the I/O combined module (transistor output part) have the overload protection function and the overheat protection function.

Overload protection function

If the I/O module detects overcurrent, the module performs the current limiting operation (which limits the overcurrent to a certain value to continue to provide output).

For the overcurrent detection value and the limited current, refer to the overload protection function in the specifications for each I/O module.

☞ Page 46 Output module

☞ Page 79 I/O combined module

If the load current becomes equal to the overcurrent detection value or lower, the module returns to normal operation.

Overheat protection function

If the I/O module keeps outputting the overcurrent caused by an overload, heat is generated inside the I/O module. If excessive heat is detected within the I/O module, it turns off the output.

The multiple points at which the overheat protection function operates depend on the I/O module. Refer to the "Overheat protection function" column in the specifications table for each I/O module.

☞ Page 46 Output module

☞ Page 79 I/O combined module

If the heat descends, the module automatically returns to normal operation.

Point

The overload protection function and the overheat protection function do not protect external devices; they protect the internal circuit of the I/O module.

An abnormal load may raise the internal temperature of the I/O module, causing deterioration in output elements and discoloration of the case and the printed-circuit board. Turn off the corresponding output as soon as a problem on a load is found, and remove the cause.

8.7 Module Power Supply Voltage Drop Detection Function

Detects a voltage drop of the module power supply.

This function makes troubleshooting easy when the voltage of power supplied to the I/O module drops or when poor connection in the wiring occurs.

Operation

The module power supply voltage drop detection function starts from the time 500ms passes after the I/O module is powered on.

When the module power supply voltage drops below 20.4VDC, a module power supply voltage drop error (error code: 0240H) occurs.

Precautions

The voltage to be detected varies depending on the environment.

When an error is detected, since the power supply environment is out of specification range, the operation is not guaranteed. A power supply voltage drop is not detected in the event of a sudden power failure or when power-off operation is performed.

8.8 External Power Supply Monitoring Function

Monitors the ON/OFF status of the external power supply.

Setting method

Sets whether to enable or disable the external power supply monitoring function with External power supply monitor request (RWw2.b9).

Remote register	State	Setting value
External power supply monitor request (RWw2.b9)	On	External power supply monitoring function enable
	Off	External power supply monitoring function disable

The setting status of the external power supply monitoring function can be checked with External power supply monitor status (RWr2.b9). For details, refer to the following.

 Page 229 External power supply monitor status (RWr2.b9)

Operation

When External power supply monitor request (RWw2.b9) is turned on, if a state of external power supply being turned off is detected, an external power supply OFF error (error code: 0104H) occurs.

Precautions

- When using the external power supply monitoring function, check that the external power supply stabilizes before turning on External power supply monitor request (RWw2.b9). Also, turn off External power supply monitor request (RWw2.b9) before turning off the external power supply.
- This function cannot be used for the MELSEC-Q series Simple Motion module.

8.9 Firmware Update Function

This function updates the firmware of the I/O module via CC-Link IE TSN.

For details on the firmware update function, refer to the following.

 CC-Link IE TSN Remote I/O Module User's Manual (CC-Link IE TSN Communication Mode)

Precautions

- The firmware cannot be updated in the CC-Link IE Field Network communication mode. Update in the CC-Link IE TSN communication mode.
- When a firmware update is performed, the firmware in the CC-Link IE TSN communication mode and in the CC-Link IE Field Network communication mode are updated.

9 PROGRAMMING

This chapter describes the programming of the I/O module.

9.1 Precautions for Programming

This section describes precautions to create CC-Link IE Field Network programs.

Cyclic transmission program

For a cyclic transmission program, interlock with the following link special relay (SB) and link special register (SW).

- Own station data link status (master station) (SB0049)
- Data link status (each station) (SW00B0 to SW00B7)

User's manual for the master/local module used

Ex.

Interlock example

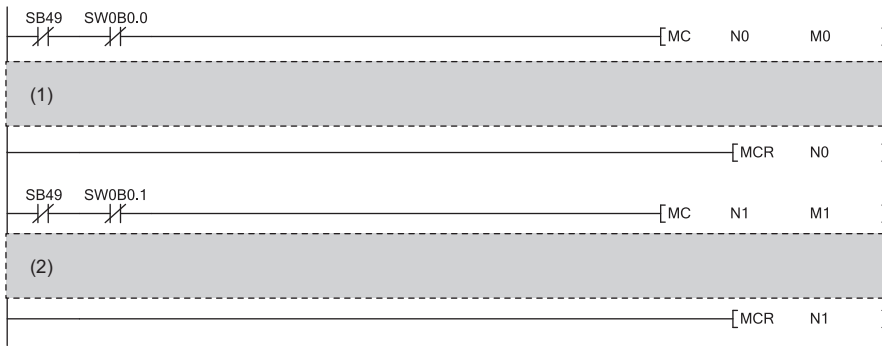

- (1) Program of communication with a station with station number 1
- (2) Program of communication with a station with station number 2

Program for transient transmission

For a program for transient transmission, provide interlock between the following link special relay (SB) and the link special register (SW).

- Baton pass status of the own station (master station) (SB0047)
- Baton pass status of each station (SW00A0 to SW00A7)

User's manual for the master/local module used

Ex.

Interlock example

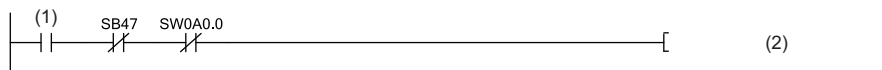

- (1) Start contact
- (2) Dedicated instruction to station No. 1

CC-Link IE Field Network synchronous communication program

For a CC-Link IE Field Network synchronous communication program, interlock with the following link special register (SW). The program is to check that I/O module operation is synchronized properly.

If the module operation is not synchronized due to a factor such as an error, prevent an unintended operation by stopping I/O control.

- Synchronous/asynchronous operation status information (each station) (SW01C8 to SW01CF) of the master station

📖 User's manual for the master/local module used

Ex.

Example of interlock when X0 and Y10 of the I/O module on the station No.1 are assigned to X1000 and Y1010 of the CPU module respectively

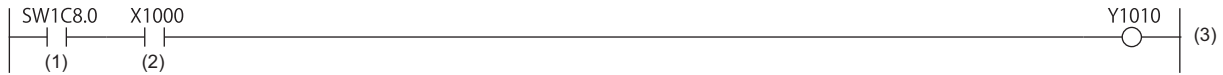

- (1) Synchronous/asynchronous operation status information (each station) of the station No.1
- (2) X0 of the station No.1
- (3) When X0 of the I/O module turns on, Y10 turns on.

9.2 Program Example

System configuration

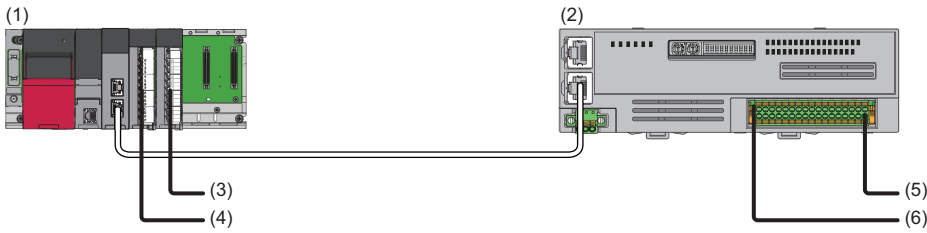

- (1) Master station
 - Power supply module: R62P
 - CPU module: R120CPU
 - Master/local module: RJ71GF11-T2 (Start I/O number: 0000H to 001FH)
 - Input module: RX40C7 (Start I/O number: 0020H to 002FH)
 - Output module: RY40NT5P (Start I/O number: 0030H to 003FH)
- (2) Intelligent device station (IP address/station number setting switches: 1)
 - I/O module: NZ2GN2S1-32DT
- (3) Y30: Error lamp
- (4) X20: Error clear switch
- (5) Y1010: Lamp
- (6) X1000: Push button switch

Assignment of link devices

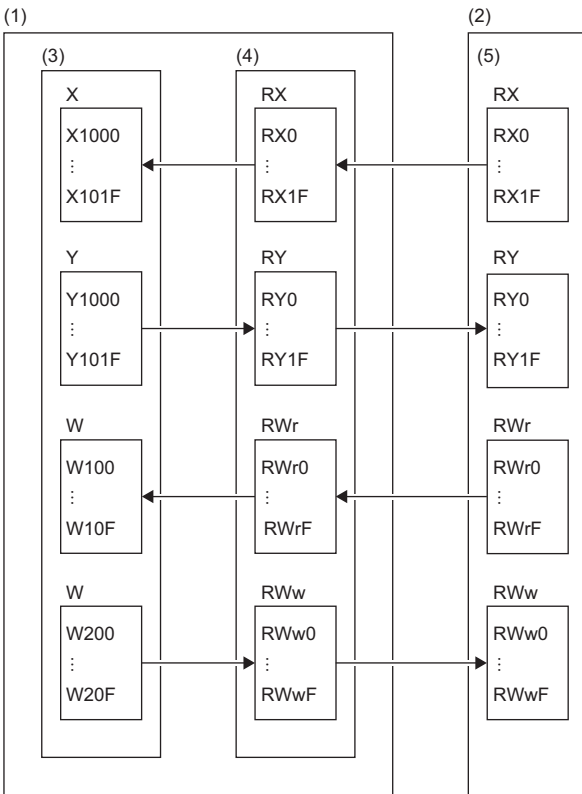

- (1) Master station
- (2) Intelligent device station
- (3) CPU module
- (4) Master/local module
- (5) I/O module

Programming condition

When RX0 of the I/O module turns on, RY10 turns on.

When an error occurs, an output module (RY40NT5P) outputs a digital signal.

Devices to be used

Device	Description	
X1000	RX0 input signal (push button) of the I/O module	NZ2GN2S1-32DT (RX0 to RX1F)
Y1010	RY10 output signal (lamp) of the I/O module	NZ2GN2S1-32DT (RY0 to RY1F)
X20	Error clear switch	Input module (X20 to X2F)
Y30	Error lamp	Output module (Y30 to Y3F)
D100	Error code	
M0	Contact for master control	
N0	Nesting	
SB49	Own station data link status (master station)	
SM400	Always ON	
SW0B0.0	Data link status (station No.1)	
W100.A	Error flag	
W101	Error code	Device to be written by link refresh
W200.A	Error clear request flag	

Setting procedure

Operating procedure

1. Create a project.

[Project] ⇒ [New...]

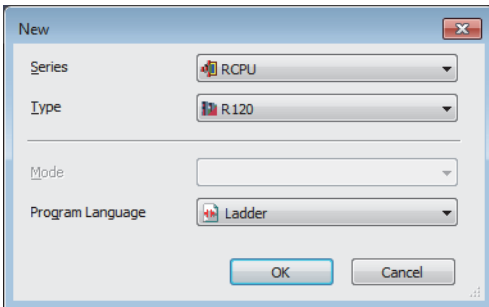

2. For the master/local module, set CC-Link IE Field Network master (RJ71GF11-T2).

[Navigation window] ⇒ [Parameter] ⇒ [Module Information] ⇒ Right-click ⇒ [Add New Module]

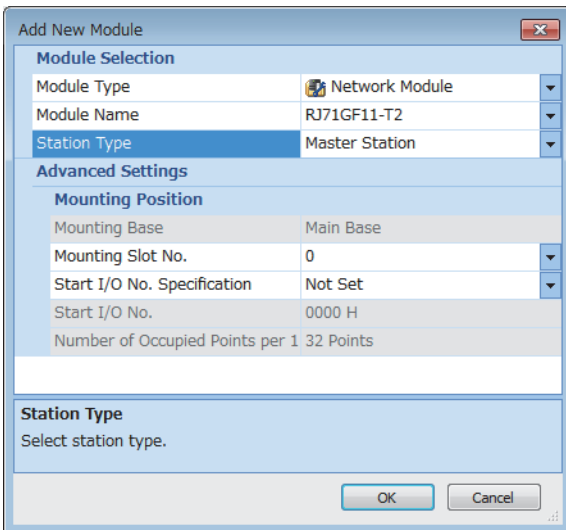

3. Display the CC IE Field Configuration window and set as follows.

[Navigation window] ⇒ [Parameter] ⇒ [Module Information] ⇒ Model ⇒ [Basic Settings] ⇒ [Network Configuration Settings]

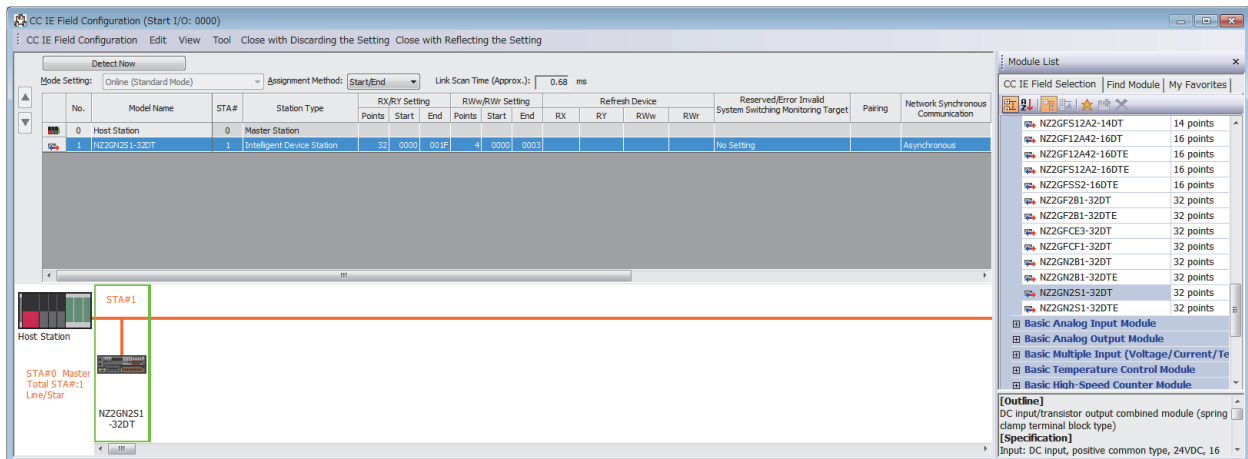

4. Click the [Close with Reflecting the Setting] button to close the CC IE Field Configuration window.

5. Display the refresh parameter setting window and configure the setting as follows.

[Navigation window] ⇒ [Parameter] ⇒ [Module Information] ⇒ Model ⇒ [Basic Settings] ⇒ [Refresh Settings]

No.	Link Side					CPU Side				
	Device Name	Points	Start	End		Target	Device Name	Points	Start	End
-	SB	512	00000	001FF	↔	Specify Device	SB	512	00000	001FF
-	SW	512	00000	001FF	↔	Specify Device	SW	512	00000	001FF
1	RX	32	00000	0001F	↔	Specify Device	X	32	01000	0101F
2	RY	32	00000	0001F	↔	Specify Device	Y	32	01000	0101F
3	RWw	16	00000	0000F	↔	Specify Device	W	16	00100	0010F
4	RWw	16	00000	0000F	↔	Specify Device	W	16	00200	0020F

6. Click the [Apply] button.

7. Write the set parameters to the CPU module of the master station and reset the CPU module of the master station, or turn off and on the power supply of the programmable controller.

[Online] ⇒ [Write to PLC]

8. Set the CPU module of the master station to RUN, and check that the DATA LINK LED of the I/O module is turned on.

Program example

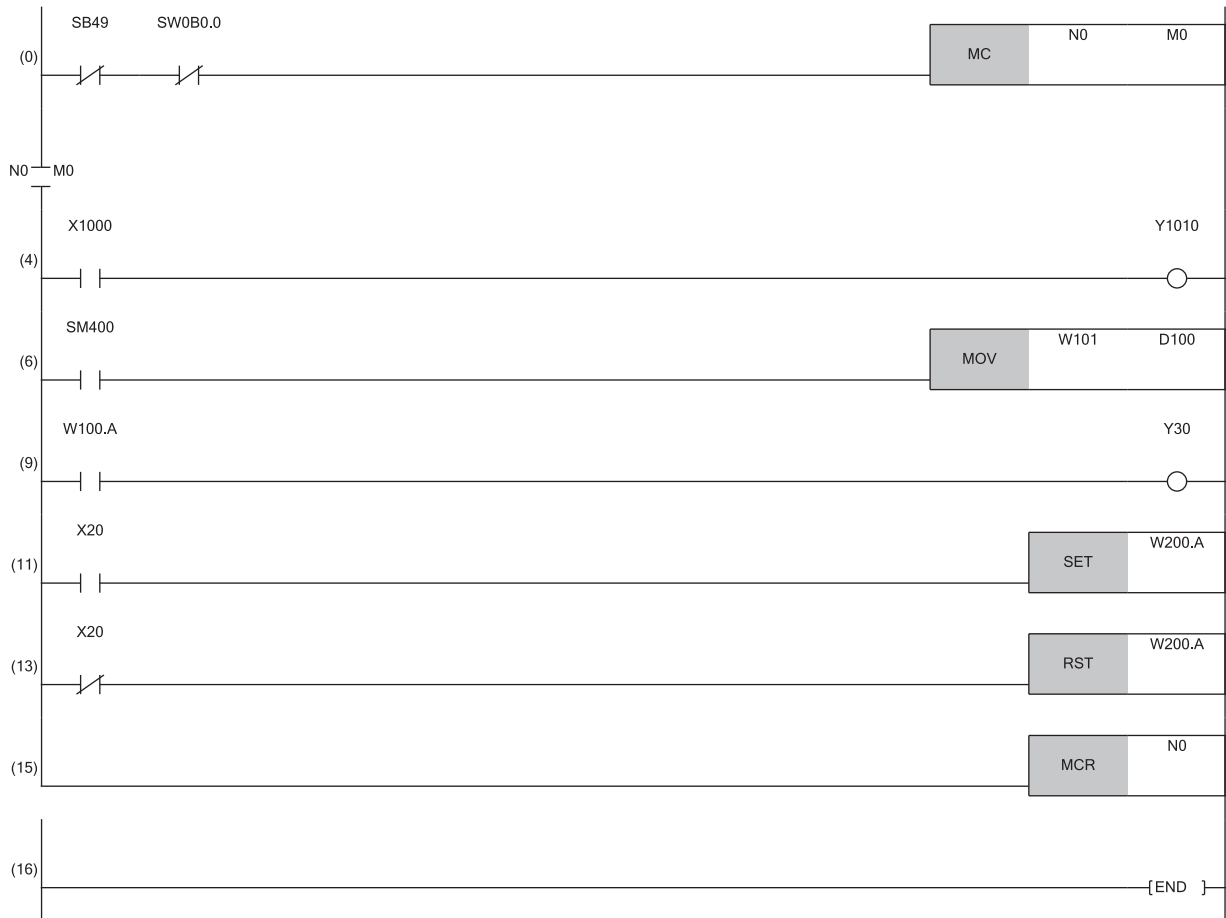

- (4) When RX0 of the I/O module is on, turn RY10 of the I/O module on.
- (6) Read the latest error code.
- (9) Perform the processing to be performed when an error occurs.
- (11) Clear the error code.

9.3 Program Example for Using the Fast Link-Up Function

This section describes tool switching with the fast link-up function using examples.

System configuration

The following figure shows the system configuration. Switch between tool 1 and tool 2 with the tool changer.

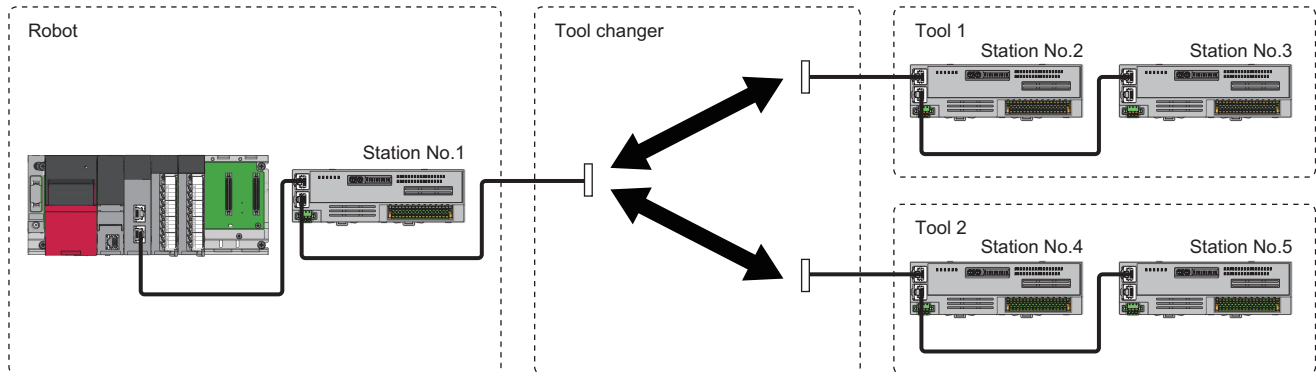

Program overview

Prepare for the following processing for each tool.

A series of tool operations will be completed by performing connection, control, and disconnection, in this order.

■Connection

Move the arm and control the tool changer to connect to a target tool. Check that data link of all I/O modules in the target tool system has been completed, and proceed to the next process, control.

■Control

Actually input or output values to control the tool. When the control is completed, proceed to the next process, disconnection.

■Disconnection

Control the tool changer to disconnect the target tool from the arm. Check for a disconnection (data link error) of the I/O modules connected with the tool changer in the target tool system. The tool operation is completed.

Setting PLC parameters

In a program example, the low-speed timer is used.

Set "Low Speed Timer/Low Speed Retentive Timer" of "Timer Limit Setting" in the [Operation Related Setting] tab to "100ms".

🖱️ Project window ⇒ [Parameter] ⇒ [CPU Parameter] ⇒ [Operation Related Setting] tab

The screenshot shows the 'R04CPU CPU Parameter' dialog box. The 'Setting Item List' on the left shows the navigation path: Operation Related Setting > Timer Limit Setting. The main 'Setting Item' table is as follows:

Item	Setting
Timer Limit Setting	
Low Speed Timer/Low Speed Retentive Timer	100 ms
High Speed Timer/High Speed Retentive Timer	10.00 ms
Long Timer/Long Retentive Timer	0.001 ms
RUN-PAUSE Contact Setting	
RUN	
PAUSE	
Remote Reset Setting	
Remote Reset	Disable
Output Mode Setting at STOP to RUN	
Output Mode at STOP to RUN	Output the Output (Y) Status before STOP
Module Synchronous Setting	
Module Rising	Synchronize
Clock Related Setting	
Time Zone	UTC+9
Comment	
<input type="checkbox"/> Setting to Adjust Clock for Daylight Saving Time	

The 'Explanation' section at the bottom provides details for the selected setting:

Explanation
 Set the timer limit value of timer (T) which used as low speed timer and timer type structured data type.
 Set the timer limit value of retentive timer (ST) used as the low speed retentive timer and retentive timer type structured data type.
 [Setting range]
 1 to 1000 [ms](1ms Unit)

Buttons at the bottom include 'Check', 'Restore the Default Settings', and 'Apply'.

Devices used by user

Device	Description
M1000	Indicates that a tool is connected and in operation.
M1100	Turn on this device to connect and operate tool 1.
M1101	Starts the program to connect tool 1.
M1102	Starts the program to control tool 1.
M1103	Starts the program to disconnect tool 1.
M1104	Turns on at completion of the disconnection of tool 1.
M1200	Turn on this device to connect and operate tool 2.
M1201	Starts the program to connect tool 2.
M1202	Starts the program to control tool 2.
M1203	Starts the program to disconnect tool 2.
M1204	Turns on at completion of the disconnection of tool 2.
SW00B0	Performs monitoring to detect disconnection and return of an I/O module. Use the following. SW00B0.1: Monitoring the module of station No.2 of tool 1 SW00B0.2: Monitoring the module of station No.3 of tool 1 SW00B0.3: Monitoring the module of station No.4 of tool 2 SW00B0.4: Monitoring the module of station No.5 of tool 2
T0	Counts the waiting time (1 second) required to change from tool 1 to the tool 2.

Program condition

To connect and operate tool 1, turn on M1100 (Tool 1 operation start).

Disconnection of the tool will be automatically performed at completion of the tool 1 operation (connection and control).

To connect and operate tool 2, turn on M1200 (Tool 2 operation start).

Disconnection of the tool will be automatically performed at completion of the tool 2 operation (connection and control).

Program example

■ Tool 1 program

Connection of tool 1

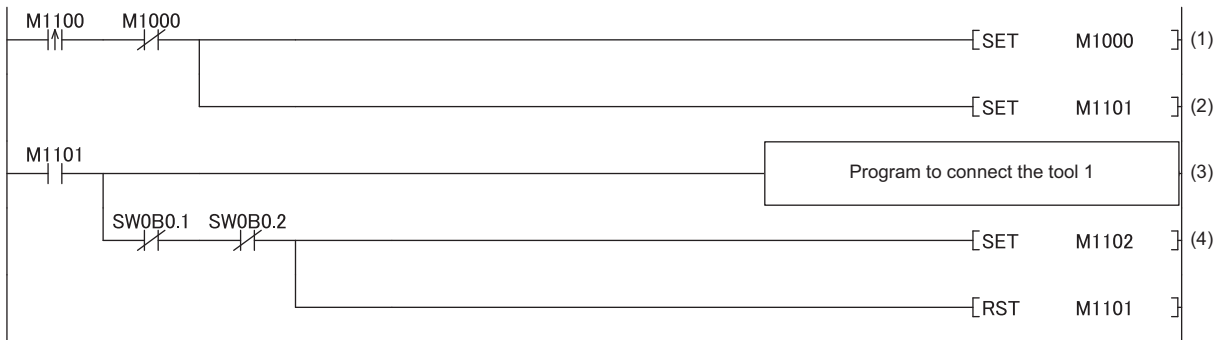

- (1) Turn on Tool 1 operation start.
- (2) When the tool is not operating, the tool 1 connection command turns on.
- (3) Execute the program to connect tool 1.
- (4) The control command turns on after the returns of the modules of station No.2 and No.3 (data link normally operating stations) are checked.

Control of tool 1

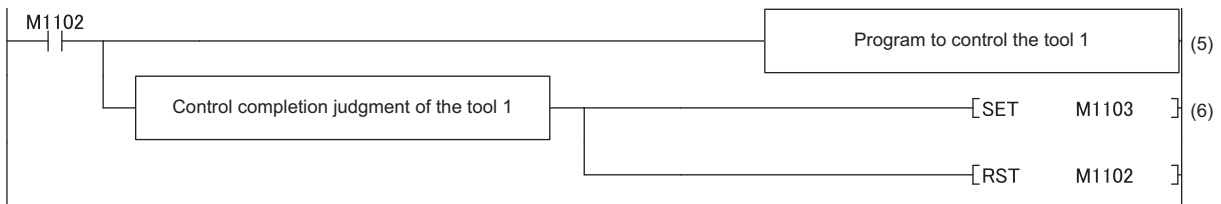

- (5) Execute the program to control tool 1.
- (6) The disconnection command turns on after completion of the control of tool 1 is checked.

Disconnection of tool 1

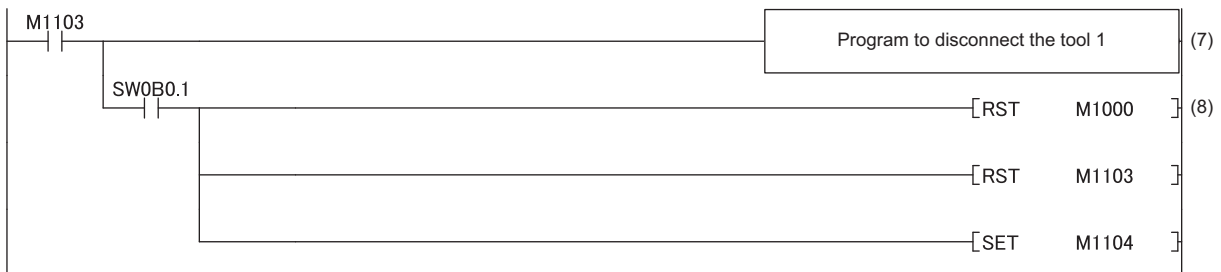

- (7) Execute the program to disconnect tool 1.
- (8) Tool operating turns off and Tool 1 operation completed turns on after the disconnection of the module of station No.2 (data link faulty station) is checked.

■ Tool 2 program

Connection of tool 2

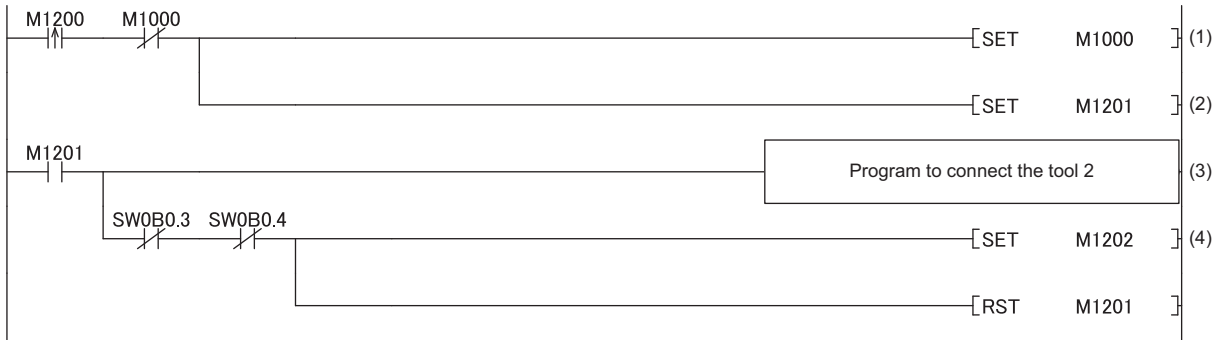

- (1) Turn on Tool 2 operation start.
- (2) When the tool is not operating, the tool 2 connection command turns on.
- (3) Execute the program to connect tool 2.
- (4) The control command turns on after the returns of the modules of station No.4 and No.5 (data link normally operating stations) are checked.

Control of tool 2

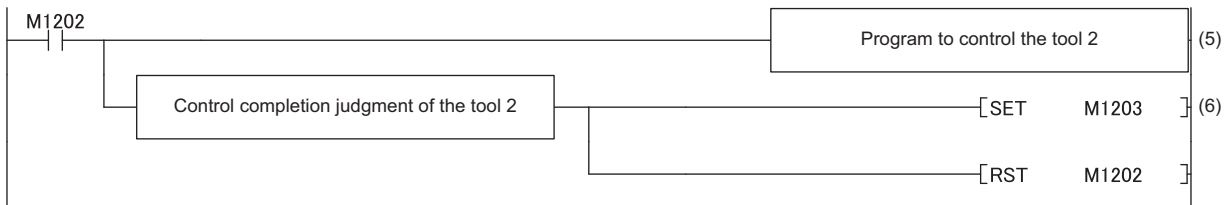

- (5) Execute the program to control tool 2.
- (6) The disconnection command turns on after completion of the control of tool 2 is checked.

Disconnection of tool 2

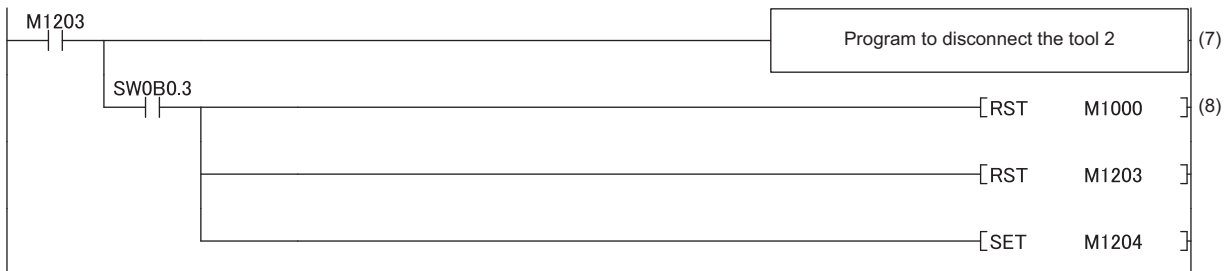

- (7) Execute the program to disconnect tool 2.
- (8) Tool operating turns off and Tool 2 operation completed turns on after the disconnection of the module of station No.4 (data link faulty station) is checked.

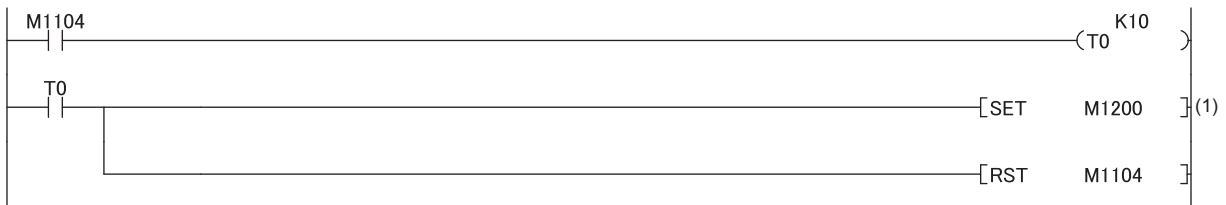

■ Program to immediately start the tool 2 operation after completion of the tool 1 operation



- (1) After the tool 1 operation has been completed, the tool 2 operation starts.

10 MAINTENANCE AND INSPECTION

The I/O module has no special item to be inspected. However, to maintain the best condition of the system, perform the inspection in accordance with the items described in either of the following manuals, depending on the system configuration of the master station used.

- MELSEC iQ-R series:  MELSEC iQ-R Module Configuration Manual
- Except for MELSEC iQ-R series:  User's manual for the CPU module used

MEMO

11 TROUBLESHOOTING

This chapter describes error contents that may occur while the I/O module is used and those troubleshooting. This chapter uses GX Works3 for explanations.

11.1 CC-Link IE TSN/CC-Link IE Field Diagnostics

For CC-Link IE Field Network, monitor the status and conduct an operation test.
For details on CC-Link IE TSN/CC-Link IE Field diagnostics, refer to the following.

User's manual for the master station used

How to use

1. Connect GX Works3 to the CPU module.
2. Start CC-Link IE Field Network diagnostics from the menu of GX Works3.

[Diagnostics] ⇒ [CC-Link IE TSN/CC-Link IE Field Diagnostics]

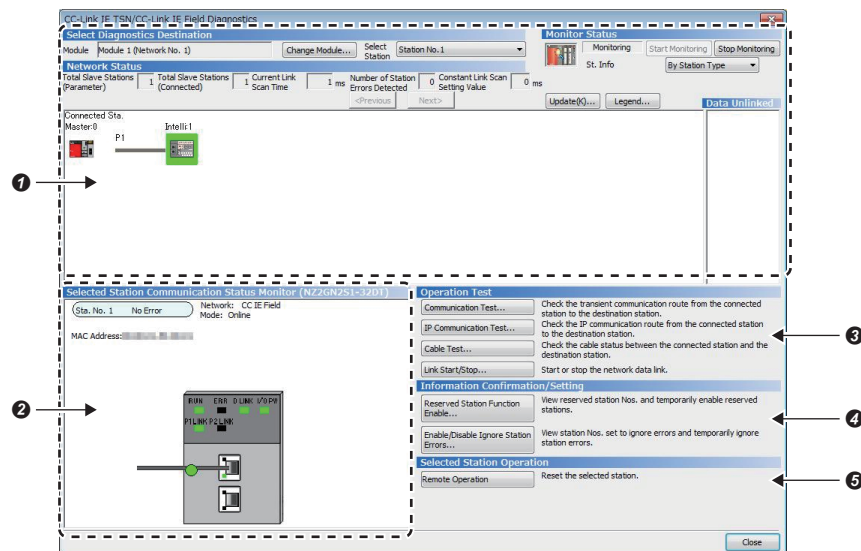

Item to be diagnosed	Description	Reference
1	Network configuration diagram and error status The status of CC-Link IE Field Network can be checked. When an error occurs in the I/O module, the status of the station is displayed on an icon.	Manual for the master/local module used
2	Selected-station status and error details The communication status of the station selected in "Network Status" can be checked.*1	
3	Communication Test The transient communication route and whether the communication is established from the connected station to the destination station can be checked.	
	IP Communication Test This item cannot be performed in the I/O module in CC-Link IE Field Network communication mode.	
	Cable Test The cable status between the connected station and the destination station can be checked.	
	Link Start/Stop The network data link can be started or stopped.	
4	Reserved Station Function Enable A reservation for a station can be temporarily cancelled, and the cancellation can be disabled. Also, the station numbers for the modules set as reserved stations can be checked on a list.	
	Enable/Disable Ignore Station Errors A station not set as an error invalid station can be temporarily set as an error invalid station, and the error invalid station setting can be disabled. Also, the station numbers for the modules set as (temporarily) error invalid stations can be checked on a list.	
5	Remote Operation The remote operation of the selected station can be started and the module status can be changed. The remote reset can be performed for the I/O module.	Page 187 Remote reset

*1 At the lower left of the window, the "Selected Station Communication Status Monitor" shows the communication status of the I/O module.
For how to check errors of the I/O module, refer to the following.

 Page 205 Method for Checking Error Codes

Point 

Some of items cannot be diagnosed depending on the master/local module used.

For details, refer to the following.

 User's manual for the master/local module used

Remote reset

Perform the following operation to remotely reset a selected I/O module.

Operating procedure

1. Select a slave station to be reset and click the [Remote Operation] button.

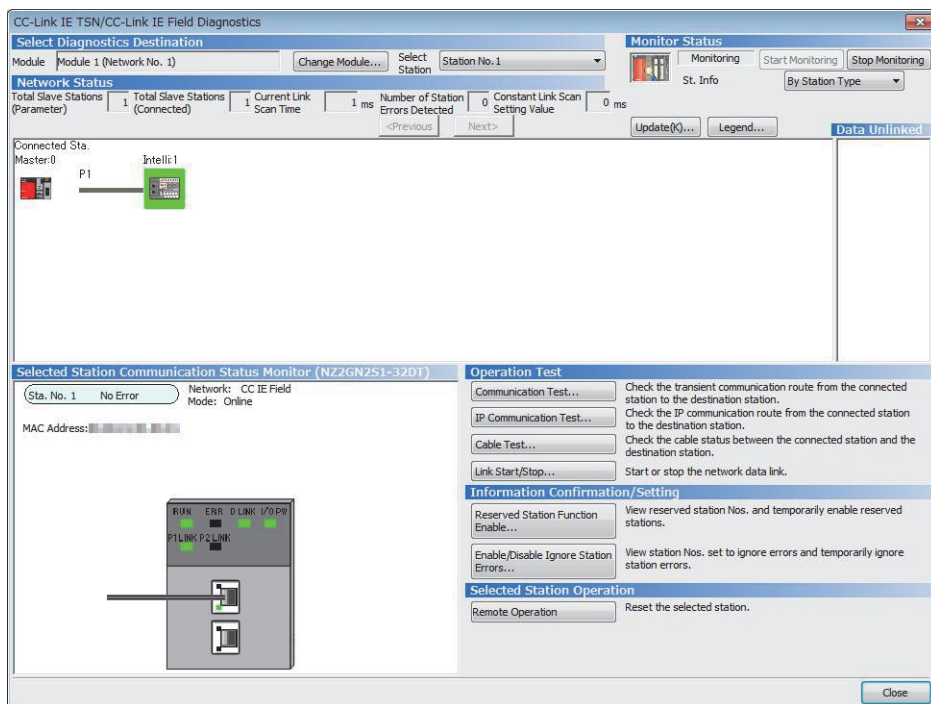

2. Follow the on-screen instructions and click the [Yes] button.
3. Follow the on-screen instructions and click the [OK] button.

Precautions

■ Setting of function setting switches

When remote reset is performed, if the setting of function setting switch 1 is different from the setting at power-on, remote reset disable error (error code: 0270H) occurs, and the I/O module is not reset.

11.2 Checking the LEDs

This section describes how to troubleshoot the system by the LEDs.

Determining the module error status

An error status can be determined by the On/Off status of RUN LED and ERR. LED as follows.

RUN LED	ERR. LED	Error type*1	Description
Off	On*2	Major error	When this error occurs, the module stops operating, and the customer must consult with their local Mitsubishi representative for troubleshooting.
On	On	Moderate error	When this error occurs, the module stops operating, but the error can be handled through operation by the customer.
On	Flashing	Minor error	When this error occurs, the module continues to operate.

*1 When multiple errors occur, the error status is displayed in the order of major error > moderate error > minor error.

*2 When the module is faulty, the LED may not turn on.

When the PW LED does not turn on

When the PW LED does not turn on, check the following items.

Check item	Action
Is any LED other than the PW LED turned on?	When any LED other than the PW LED turns on, the possible cause is a hardware error. Please consult your local Mitsubishi representative.
Is the module power supply (24VDC) wired?	Wire the module power supply (24VDC).
Is the module power supply (24VDC) turned on?	Turn on the module power supply (24VDC).
Is the voltage of the module power supply (24VDC) within the specified range?	Set the voltage value within the range of performance specifications.

When the RUN LED does not turn on

When the RUN LED does not turn on, check the following items.

Check item	Action
Has any hardware error occurred?	Check that the module power supply voltage is within the range of performance specifications. (☞ Page 21 Performance Specifications) After the check, power off and on the module. If the RUN LED does not turn on even after the module power supply is turned off and on, the possible cause is a module failure. Please consult your local Mitsubishi representative.

When the RUN LED flashes

When the RUN LED flashes, check the following items.

Check item	Action
Is the IP address/station number setting switch (x16) of the I/O module set to F, and is function setting switch 1 set to ON?	When a unit test is conducted on the I/O module, the RUN LED turns on after the unit test is completed. Take corrective action according to the result of the unit test. (☞ Page 192 Unit Test) When a unit test is not conducted, set the IP address/station number setting switches to an appropriate value, and set function setting switch 1 to ON.

When the ERR. LED turns on or flashes

When the ERR. LED turns on or flashes, check the following items.

Check item	Action
Has any error occurred?	Identify the error factor of the I/O module with the engineering tool to take the corrective action. (🔧 Page 205 Method for Checking Error Codes)

When the P1 LINK LED or P2 LINK LED turns off

When the P1 LINK LED or P2 LINK LED turns off, check the following items.

Check item	Action
Are Ethernet cables used compliant with the relevant standard?	Replace the cable with an Ethernet cable compliant with the relevant standard. (📖 User's manual for the master/local module used)
Is the segment length 100m or less?	Change the segment length to 100m or less.
Does the cabling condition (bending radius) meet the specifications?	Refer to the manual for the Ethernet cable used, and correct the bending radius.
Is any Ethernet cable disconnected?	Replace the Ethernet cable.
Do other stations connected to the I/O module normally operate?	Check that the power supplies of the other stations are turned on.
Does the switching hub in use normally operate?	<ul style="list-style-type: none"> • Check that the power supply of the switching hub is turned on. • Check that the switching hub that meets the specifications of the master module in use is used. (📖 User's manual for the master/local module used) • Disconnect Ethernet cables, and then reconnect them. • Power off and on the switching hub.
Are the modules where the state (enable/disable) of the fast link-up function is the same connected to each other?	For the ports connected to each other, set the same state (enable/disable) for the fast link-up function. And then power off and on the modules. In addition, disable the fast link-up function for the port that is to be connected to the port where the fast link-up function is not supported.
For the modules to be connected to each other with the fast link-up function being enabled, are P1 and P2 connected with a cable?	Connect P1 and P2 with a cable when connecting modules where the fast link-up function is enabled.

Point

If link-up processing is repeated due to a condition of a device on the line, it may take a longer time for the P1 LINK LED/P2 LINK LED to turn on.

This phenomenon may be eliminated by changing the PORT of the relevant module to which the Ethernet cable is connected (example: PORT1→PORT2).

For details on Ethernet cable wiring, refer to the following.

🔧 Page 131 Wiring of Ethernet Cable

When the DATA LINK LED turns off

When the DATA LINK LED turns off, check the following items.

Check item	Action
Are Ethernet cables used compliant with the relevant standard?	Replace the cable with an Ethernet cable compliant with the relevant standard. (📖 User's manual for the master/local module used)
Is the segment length 100m or less?	Change the segment length to 100m or less.
Does the cabling condition (bending radius) meet the specifications?	Refer to the manual for the Ethernet cable used, and correct the bending radius.
Is any Ethernet cable disconnected?	Replace the Ethernet cable.
Does the master station connected to the network operate normally?	<ul style="list-style-type: none"> • If an error occurs in the master station, clear the error in the master station. • Check that the master station in use is a supported master station. (📖 Page 108 Applicable master station)
Do other stations connected to the I/O module normally operate?	Check that the power supplies of the other stations are turned on.
Does the switching hub in use normally operate?	<ul style="list-style-type: none"> • Check that the power supply of the switching hub is turned on. • Check that the switching hub that meets the specifications of the master module in use is used. (📖 User's manual for the master/local module used) • Disconnect Ethernet cables, and then reconnect them. • Power off and on the switching hub.
Is the station number of the I/O module duplicated with any of the other devices within the access range of CC-Link IE Field Network?	Change the station number so that no station number duplication occurs in the access range of CC-Link IE Field Network.
Is function setting switch 1 turned on?	Turn on function setting switch 1 if it is turned off, and turn off and on the module power supply.
Are the IP address/station number setting switches set to a value other than 1 to 120?	For the station number, the effective range is 1 to 120. Change the station number to within the range from 1 to 120.
Is a device that is operating as a network other than CC-Link IE Field Network connected between the master station and the I/O module?	Disconnect a device that is not operating as CC-Link IE Field Network from the system. For a device that can be set to operate on CC-Link IE Field Network, make sure that it is operating as CC-Link IE Field Network.

When the DATA LINK LED flashes

When the DATA LINK LED flashes, check the following items.

Check item	Action
Does the station number of the I/O module match the station number specified in the network configuration settings of the master station or in the CC IE Field Configuration?	Match the station number of the I/O module with the station number on the master station.
Is the station type an intelligent device station?	In the network configuration settings of the master station, change "Station type" for the I/O module to "Intelligent device station".
Is the I/O module a reserved station?	Change the setting of "Reserved/error invalid station" to a value other than "Reserved station" in the network configuration settings of the master station.
Are the IP address/station number setting switches set to a value other than 1 to 120?	For the station number, the effective range is 1 to 120. Change the station number to within the range from 1 to 120.
Is link stop displayed in CC-Link IE TSN/CC-Link IE Field Diagnostics?	Check the link status in CC-Link IE TSN/CC-Link IE Field Diagnostics, and start the link if the link is stopped.
Has the connection been changed from the connected master station to a master station with a different network number?	<ul style="list-style-type: none"> • Reconnect to the previous master station. • To communicate with a master station with a different network number, power off and on the I/O module.

When the I/O PW LED does not turn on

When the I/O PW LED does not turn on, check the following items.

Check item	Action
Is the external power supply (24VDC) wired?	Wire the external power supply (24VDC).
Is the external power supply (24VDC) turned on?	Turn on the external power supply (24VDC).
Is the voltage of the external power supply (24VDC) within the specified range?	Set the voltage value within the range of performance specifications.

11.3 Unit Test

Run a unit test to check if there is any abnormality in the hardware of I/O module.

1. Power off the I/O module.
2. Connect P1 and P2 of the I/O module with an Ethernet cable.
3. Set the IP address/station number setting switches and the function setting switches as follows.
 - IP address/station number setting switch (x1): Any position
 - IP address/station number setting switch (x16): F
 - Function setting switch 1: ON
 - Function setting switch 2 to function setting switch 10: Any position
4. Power on the I/O module.
5. Unit test begins.

The RUN LED flashes during the unit test.

6. The RUN LED turns on when the unit test is completed.
 - If the test is completed normally, the ERR. LED does not turn on, but remains off.
 - If the test is completed with an error, the ERR. LED turns on. If the test is completed with an error, replace the Ethernet cable and run the test again. If the test is completed with an error again, it may be due to a hardware error in the I/O module. Please consult your local Mitsubishi representative.

Precautions

If the I/O module is connected to the network while the IP address/station number setting switch (x16) is set to F, data link may not be properly performed on modules of other stations.

Set an appropriate value for the IP address/station number setting switch (x16), and connect the I/O module to the network.

11.4 Troubleshooting by Symptom

Perform troubleshooting by symptom when the I/O module does not operate properly even with no error. If an error occurs in the I/O module, identify the cause of the error using the engineering tool.

When the ON/OFF status of an external input cannot be read

When the ON/OFF status of an external input cannot be read, check the following items.

Check item	Action
Is the corresponding LED (X0 LED to X1F LED) of the I/O module on when an external input device is on?	<p>If the LED does not turn on, there is a problem on the input wiring. Check the wiring confirming that the input wiring is not disconnected or short-circuited, or the voltage of the input signal is correct. For the rated input voltage, check the Rated input voltage column of each I/O module specifications. ☞ Page 21 Input module ☞ Page 79 I/O combined module Refer to the following as well. ☞ Page 195 Troubleshooting for input circuit If the LED does not turn on even after the input wiring is corrected, the possible cause is an I/O module failure. Please consult your local Mitsubishi representative.</p>
When the LEDs from X0 LED to X1F LED are turned on, does the corresponding RX device turn on?	<p>If the RX device does not turn on, check and correct the refresh parameter so that the refresh device setting matches the corresponding setting in the program. For the refresh parameter setting, refer to the following. ☞ User's manual for the master station used</p>
On the network configuration settings, has the network synchronous communication setting (synchronous/asynchronous) or the setting for function setting switch 6 or function setting switch 7 been changed?	<p>When the network synchronous communication setting or the setting for function setting switch 6 or function setting switch 7 has been changed, turn off and on the power supply, or perform remote reset.</p>
Is the inter-module synchronous interrupt program created when MELSEC iQ-R series modules use the CC-Link IE Field Network synchronous communication function together with the inter-module synchronization function?	<p>Create the inter-module synchronous interrupt program when MELSEC iQ-R series modules use the CC-Link IE Field Network synchronous communication function together with the inter-module synchronization function. For the inter-module synchronous interrupt program, refer to the following. ☞ MELSEC iQ-R Inter-Module Synchronization Function Reference Manual</p>
Is there any problem with other equipment such as the master station and connected devices?	<p>If there is no problem with other equipment, the possible cause is an I/O module failure. Please consult your local Mitsubishi representative.</p>

When the ON/OFF status of an external output cannot be changed

When the ON/OFF status of an external output cannot be changed, check the following items.

Check item	Action
Is the I/O PW LED turned on?	Take corrective action according to the following. ☞ Page 191 When the I/O PW LED does not turn on
When External output signal (RY0 to RY1F) is turned on, is the corresponding LED (Y0 LED to Y1F LED) of the I/O module turned on?	If the above LED is not turned on, check and correct the refresh parameter so that the refresh device setting matches the corresponding setting in the program. For the refresh parameter setting, refer to the following. 📖 User's manual for the master/local module used
Has the setting for function setting switch 6 or function setting switch 7 been changed while External output signal (RY0 to RY1F) is used?	If the corresponding LED (Y0 LED to Y1F LED) of the I/O module is not turned on, there is a problem with the setting for function setting switch 6 or function setting switch 7. When using External output signal (RY0 to RY1F), turn off both the function setting switch 6 and the function setting switch 7. In addition, turn off and on the power supply, or perform remote reset after changing the setting for function setting switch 6 or function setting switch 7.
Are signals output from the output terminal Y on which the LED (Y0 LED to Y1F LED) is on?	If signals are not output, there is a problem with the output wiring. Check the wiring confirming that the output wiring is not disconnected or short-circuited. Refer to the following as well. ☞ Page 198 Troubleshooting for output circuit
On the network configuration settings, has the network synchronous communication setting (synchronous/asynchronous) or the setting for function setting switch 6 or function setting switch 7 been changed?	When the network synchronous communication setting or the setting for function setting switch 6 or function setting switch 7 has been changed, turn off and on the power supply, or perform remote reset.
Is the inter-module synchronous interrupt program created when MELSEC iQ-R series modules use the CC-Link IE Field Network synchronous communication function together with the inter-module synchronization function?	Create the inter-module synchronous interrupt program when MELSEC iQ-R series modules use the CC-Link IE Field Network synchronous communication function together with the inter-module synchronization function. For the inter-module synchronous interrupt program, refer to the following. 📖 MELSEC iQ-R Inter-Module Synchronization Function Reference Manual
Is RWw10 to RWw4F set for the refresh device setting while the module is operating in synchronization cycle timing control mode?	There is a problem with the refresh device setting. Check and correct the refresh parameter so that the refresh device setting matches the corresponding setting in the program.
Is the value set in Synchronization output timing setting Y□ OFF to ON/ON to OFF (RWw10 to RWw4F) exceeding the synchronization cycle while the module is operating in synchronization cycle timing control mode?	If a value exceeding the synchronization cycle is set, an external output does not change. Correct the value so that a value set in Synchronization output timing setting Y□ OFF to ON/ON to OFF (RWw10 to RWw4F) is equal to or smaller than the synchronization cycle.
Is the ON/OFF switching period of output set to be an interval shorter than the maximum output response time when the module uses synchronization cycle timing control mode?	Because the module uses synchronization cycle timing control mode, if the ON/OFF switching period of output is set to be shorter than the maximum output response time, output may not turn on or off. Correct the values of Synchronization output timing setting Y□ OFF to ON or ON to OFF (RWw10 to RWw4F) so that the ON/OFF switching period becomes longer than the maximum output response time.
Is there any problem with other equipment such as the master station and connected devices?	If there is no problem with other equipment, the possible cause is an I/O module failure. Please consult your local Mitsubishi representative.

When CC-Link IE TSN/CC-Link IE Field diagnostics cannot be performed

When CC-Link IE TSN/CC-Link IE Field diagnostics cannot be performed, check the following items.

Check item	Action
Is the version of the engineering tool supported?	Check the version of the engineering tool, and if it is prior to the compatible versions, update it.

11.5 Examples of Troubles with the I/O Module

Troubleshooting for input circuit

This section describes the troubleshooting for input circuit.

An input signal does not turn off No.1

■Cause

Drive by a switch with LED indicator

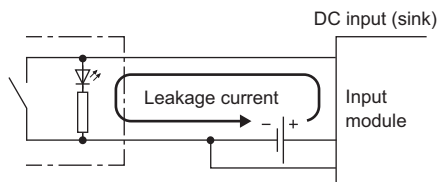

■Action

Connect an appropriate resistor as shown below so that a current through the input module may become lower than the OFF current.

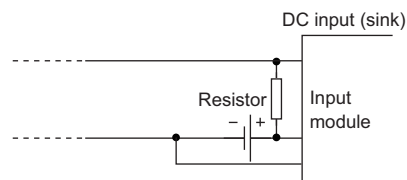

For the calculation example of a resistor to be connected, refer to the following.

■Calculation example

If the switch with LED indicator with maximum leakage current of 3mA when 24VDC external power supply is provided to the NZ2GN2B1-32D is connected

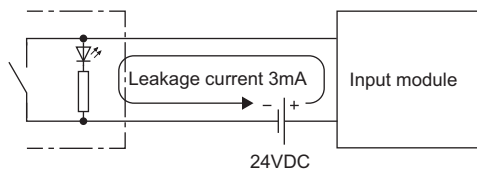

1. The OFF current of NZ2GN2B1-32D is not 1.5mA or lower. Therefore, connect a resistor as shown below.

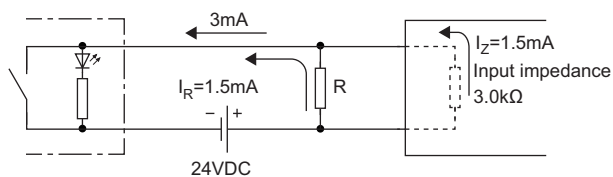

2. To satisfy the condition that the OFF current of NZ2GN2B1-32D is 1.5mA or lower, the current through the connected resistor should be 1.5mA or higher. From the formula below, the connected resistor (R) is lower than 3.0kΩ.

$I_R: I_Z = Z$ (Input impedance): R

$$R \leq \frac{I_Z}{I_R} \times Z \text{ (Input impedance)} = \frac{1.5}{1.5} \times 3.0 = 3.0[\text{k}\Omega]$$

3. When the resistor (R) is 2.5kΩ, for example, the power capacity (W) of the resistor (R) becomes 0.332W.

$$W = (\text{Input voltage})^2 \div R = 28.8^2 \div 2500 = 0.332[\text{W}]$$

4. Because the resistor requires a power capacity that is 3 to 5 times larger than the actual current consumption, the resistor connected to the terminal should be 2.5kΩ; and 1 to 2W.

5. OFF voltage when the resistor (R) is connected becomes 4.09V. This satisfies that the OFF voltage of NZ2GN2B1-32D is 5V or lower.

$$\frac{1}{\frac{1}{2.5[\text{k}\Omega]} + \frac{1}{3.0[\text{k}\Omega]}} \times 3[\text{mA}] = 4.09[\text{V}]$$

An input signal does not turn off No.2

■Cause

By using two power supplies, a sneak path is configured.

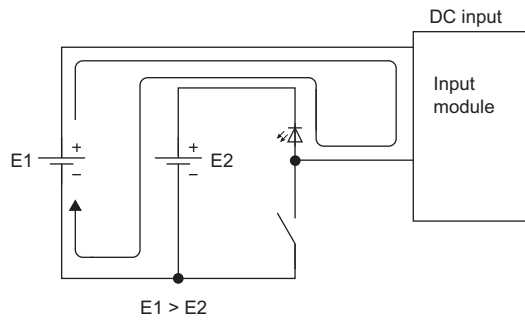

■Action

- Use one power supply.
- To prevent the sneak path, connect a diode as shown below.

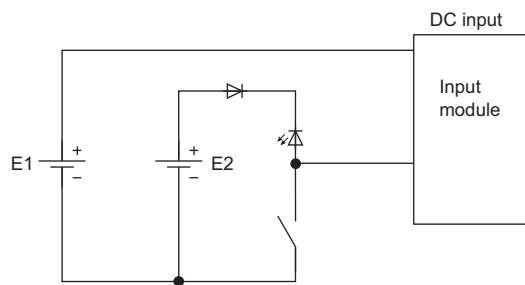

A signal incorrectly inputs data

■Cause

Noise is taken as input data.

■Action

- To prevent excessive noise, avoid installing power cables together with I/O cables.
- Set a longer input response time. (☞ Page 152 Input Response Time Setting Function)
- Connect surge absorbers to noise-generating devices such as relays and conductors using the same power supply or take other noise reduction measures.
- To prevent noise from being taken in, take measures to reduce noise for the I/O cable by using a part such as a ferrite core.
- To prevent radiation noise, take measures to reduce noise by using a shielded cable.

Troubleshooting for output circuit

This section describes the troubleshooting for output circuit.

A load momentarily turns on when the external power supply is powered on

■Cause

An incorrect output occurs due to the stray capacitance (C) between collector and emitter of a photocoupler. (When a high sensitivity load (such as solid state relay) is used, this incorrect output may occur.)

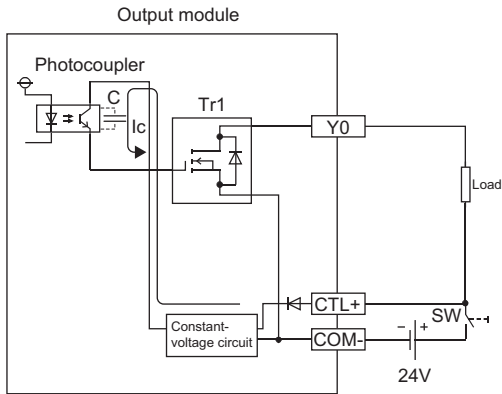

When the external power supply is powered on rapidly, the current (I_c) flows due to the stray capacitance (C). The current (I_c) flows to the gate of the transistor (Tr1) of the next stage and the output Y0 turns on for approximately 100 μ s.

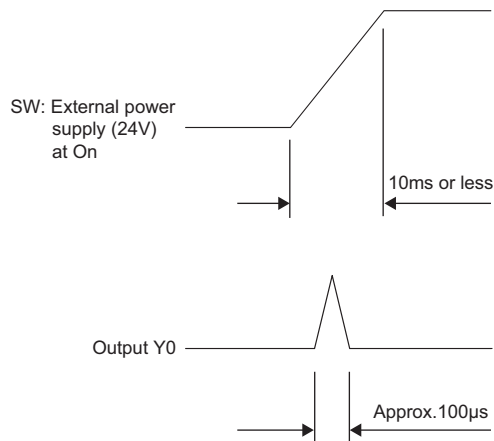

Action

Before turning on or off the external power supply, check that the rise time of the external power supply is 10ms or more. Then, install a switch (SW1) to the primary side of the external power supply.

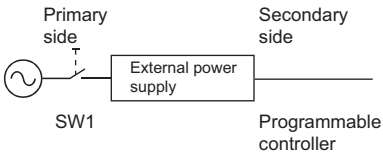

When installing the switch to the secondary side, connect a capacitor and resistor, and increase the rise time (10ms or more).

• Sink output

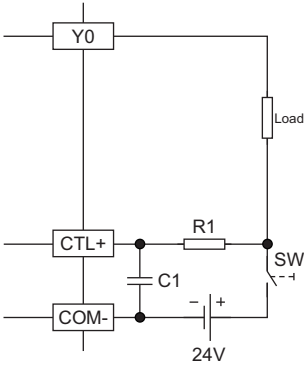

• Source output

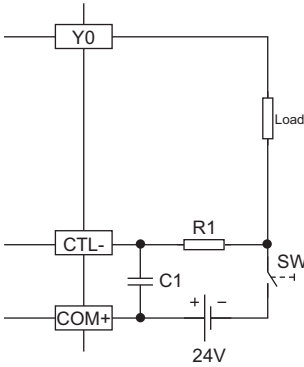

R1: Several tens of ohms

Power capacity \geq (External power supply current^{*1})² × Resistance value × (3 to 5)^{*2}

C1: Several hundreds of microfarads 50V

(Example)

R1 = 40Ω, C1 = 300μF

Time constant is calculated as shown below.

$$C1 \times R1 = 300 \times 10^{-6} \times 40$$

$$= 12 \times 10^{-3}s$$

$$= 12ms$$

*1 For details on the current consumption of the external power supply for output part to be used, refer to the performance specifications.

*2 Select the power capacity of resistor to be 3 to 5 times as large as the actual power consumption.

A load momentarily turns on from off when the system is powered off

■Cause

When an inductive load is connected, [2] Load may turn on from off due to a diversion of back electromotive force at [1] Shutoff.

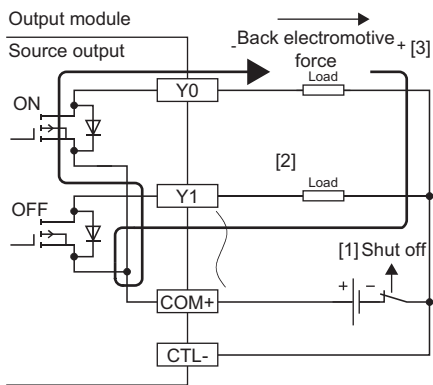
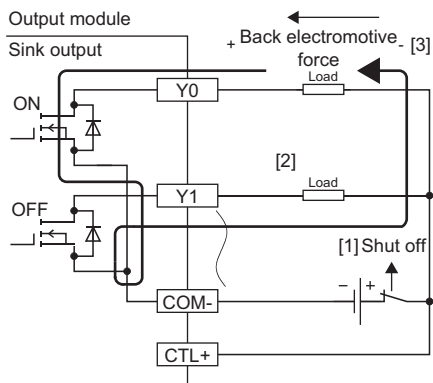

Action

Take one of the two actions shown below.

Action 1. To suppress the back electromotive force, connect a diode parallel to the load where back electromotive force is generated.

- Sink output

[3]

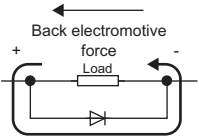

- Source output

[3]

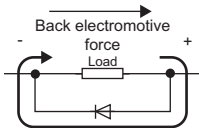

Action 2. Configure a sneak current path by connecting a diode across positive and negative of the external power supply. When taking the action described in Example 1 at a time, connect a diode parallel to C1 and R1.

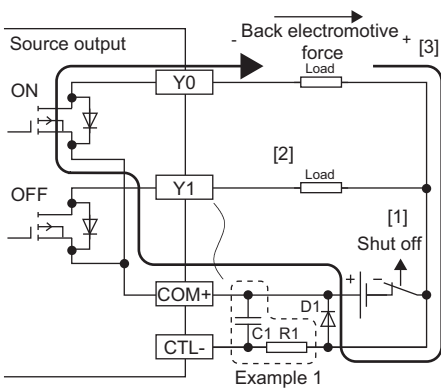
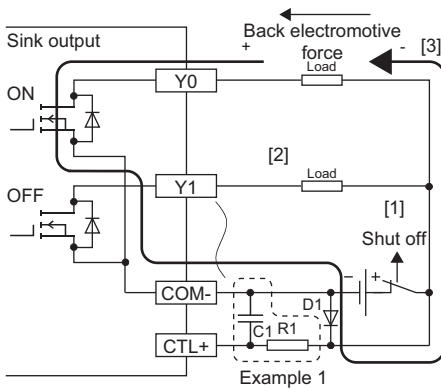

D1:

Reverse voltage VR (VRM)^{*1}

Forward current IF (IFM)^{*2}

*1 Approximately 10 times the rated voltage in the specifications
Example: 24VDC → Approx. 200VDC

*2 Twice the maximum load current (common) in the performance specifications or more
Example: 5A/1 common → 10A or more

When the output module is off, the LED connected as a load dimly turns on

■Cause

The load operates by the leakage current when the output module is off.

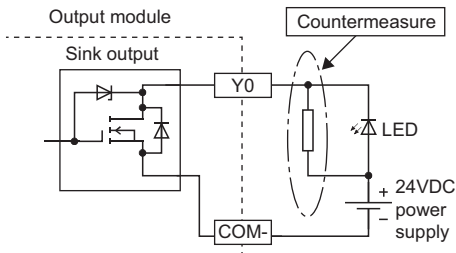

■Action

Connect a resistor of 5 to 50k Ω in parallel with the LED load.

When a digital display unit is connected as a load, data may not be displayed normally

■Cause

The load operates by the leakage current when the output module is off.

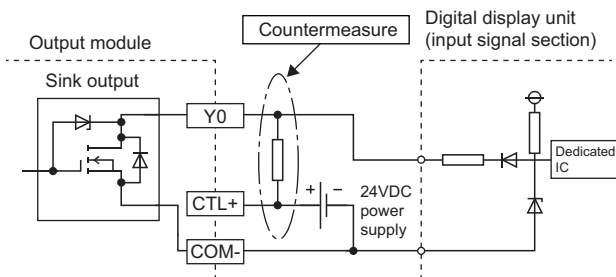

■Action

Install a pull-up resistor of 5 to 50k Ω and 0.5W between the outputs of 24VDC power supply and the output module.

When output is turned on, load connected to other outputs is turned on simultaneously

■Cause

When a non-wiring state occurs due to, for example, a shutoff or disconnection between 0V of the external power supply and the common of a load, a current flows across the load that is off through an unexpected circuit of the output element that is off.

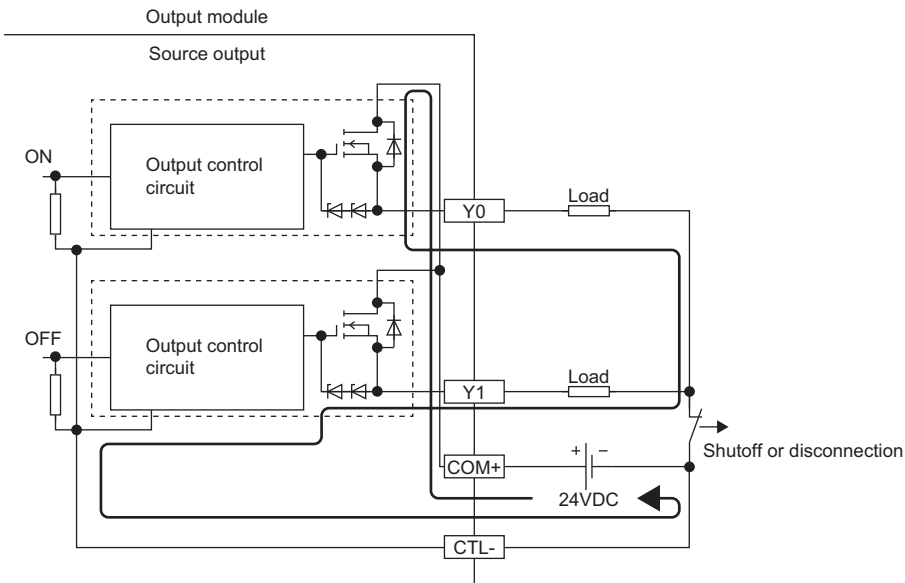

■Action

Connect external power supply and the load correctly.

To prevent the state described above, install diodes in each output terminal as shown below.

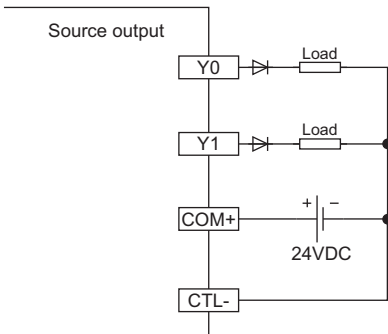

A load operates only by turning on the external power supply (transistor output)

■Cause

- The external power supply is connected with its polarity reversed.

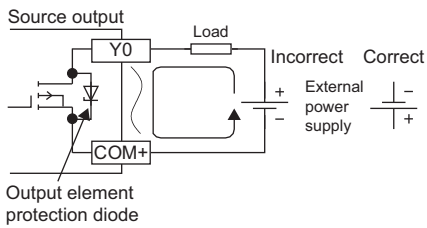
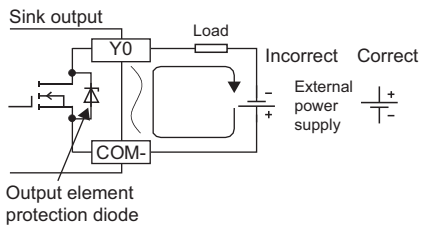

- The reversed polarity may allow current to flow via the output element protection diode into the load.

■Action

Connect the external power supply with the correct polarity.

11.6 Method for Checking Error Codes

Error codes can be checked by any of the following methods:

- Checking with the engineering tool
- Checking by Error code (RWr1)
- Checking by using CC IE Field configuration

Checking with the engineering tool

The error history held in the I/O module can be read. Errors that occurred before powering-off can be checked as well. The error history can be checked by using CC-Link IE TSN/CC-Link IE Field diagnostics.

Point

- The error history records a maximum of 15 errors in reverse chronological order of occurrence. If more than 15 errors occur, errors are deleted from the oldest.
- If the same error occurs continuously, only the error that occurred first is stored to the error history.
- The error history is stored in the non-volatile memory in the I/O module. It is not lost when the power is cut off. However, when the upper limit for the number of writes to the non-volatile memory is reached, the error history cannot be stored in the non-volatile memory.
- "Occurrence Date" information in the error history is recorded after clock information is distributed from the master station. When an error occurs before clock information is distributed from the master station, "Occurrence Date" information is not recorded.

■Checking by using CC-Link IE TSN/CC-Link IE Field diagnostics

Operating procedure

1. Connect the engineering tool to the CPU module.
2. Start CC-Link IE TSN/CC-Link IE Field diagnostics from the menu.
🔗 [Diagnostics] ⇒ [CC-Link IE TSN/CC-Link IE Field Diagnostics]
3. Right-click the slave station whose error history you want to check, and select "Error History".
4. Follow the on-screen instructions and click the [Yes] button.
5. The error history appears.

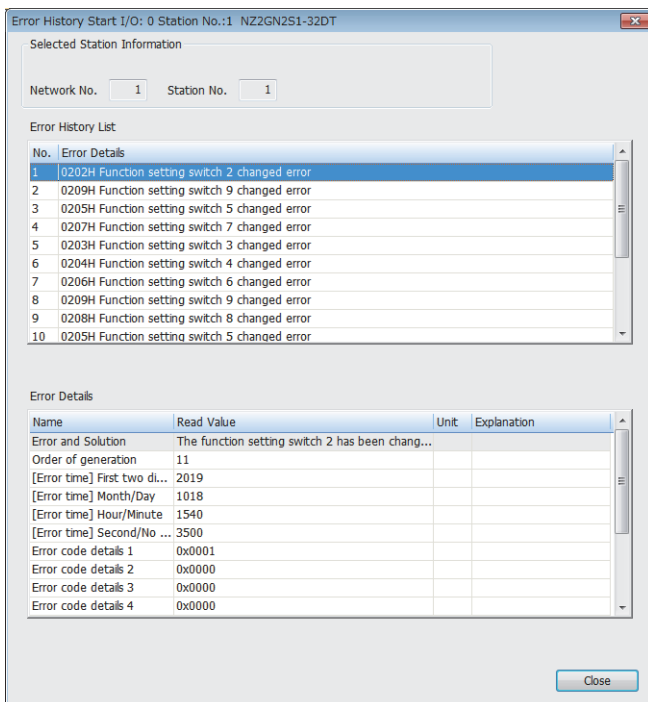

Checking by Error code (RWr1)

Check the latest error code with the remote register of the master/local module.

Operating procedure

 [Online] ⇒ [Monitor] ⇒ [Device/Buffer Memory Batch]

Ex.

When the refresh target device for Error code (RWr1) is W101

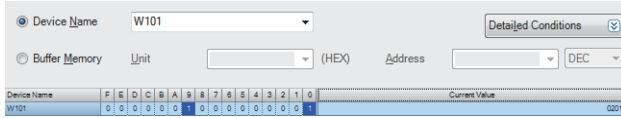

How to clear an error

How to clear an error depends on the error type.

Error type	How to clear an error
Major error	The error cannot be cleared.
Moderate error	Eliminate the error cause, and power off and on the I/O module. Or, turn on and off Error clear request flag (RWw0.b10).
Minor error	Eliminate the error cause, and power off and on the I/O module. Or, turn on and off Error clear request flag (RWw0.b10).
Communication error	Eliminate the error cause. The error does not need to be cleared.

Point 

Communication errors are not stored in the error code, but stored only in the error history.

■How to clear an error using the command execution of slave station.

Follow the procedure below to clear an error using the command execution of slave station.

Operating procedure

1. Select an I/O module from the station list on the "CC IE Field Configuration" window.

2. Open the "Command Execution of Slave Station" window.

Right-click on the target I/O module ⇒ [Online] ⇒ [Command Execution of Slave Station]

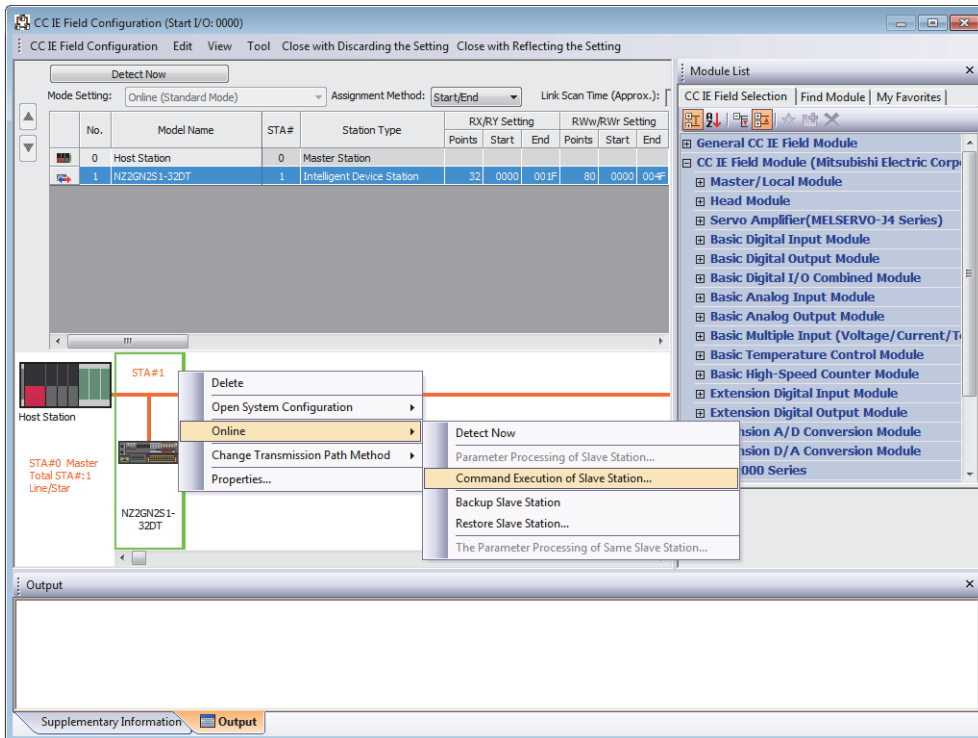

3. Set "Method selection" to "Error clear request", and click the [Execute] button.

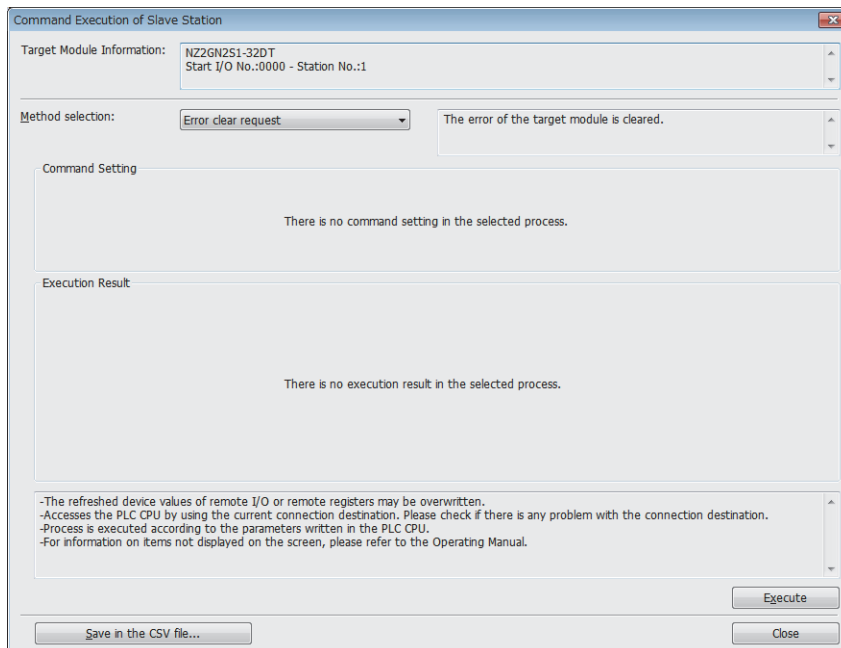

- When the following window appears, click the [OK] button.

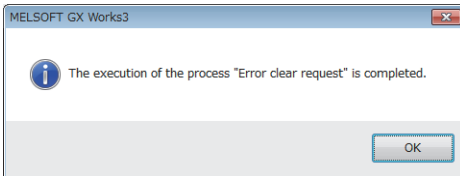

- An error on the I/O module is cleared.

Checking by using CC IE Field configuration

■How to check an error using the command execution of slave station

Follow the procedure below to check an error using the command execution of slave station.

Operating procedure

- Select an I/O module from the station list on the "CC IE Field Configuration" window.
- Open the "Command Execution of Slave Station" window.

Right-click on the target I/O module ⇒ [Online] ⇒ [Command Execution of Slave Station]

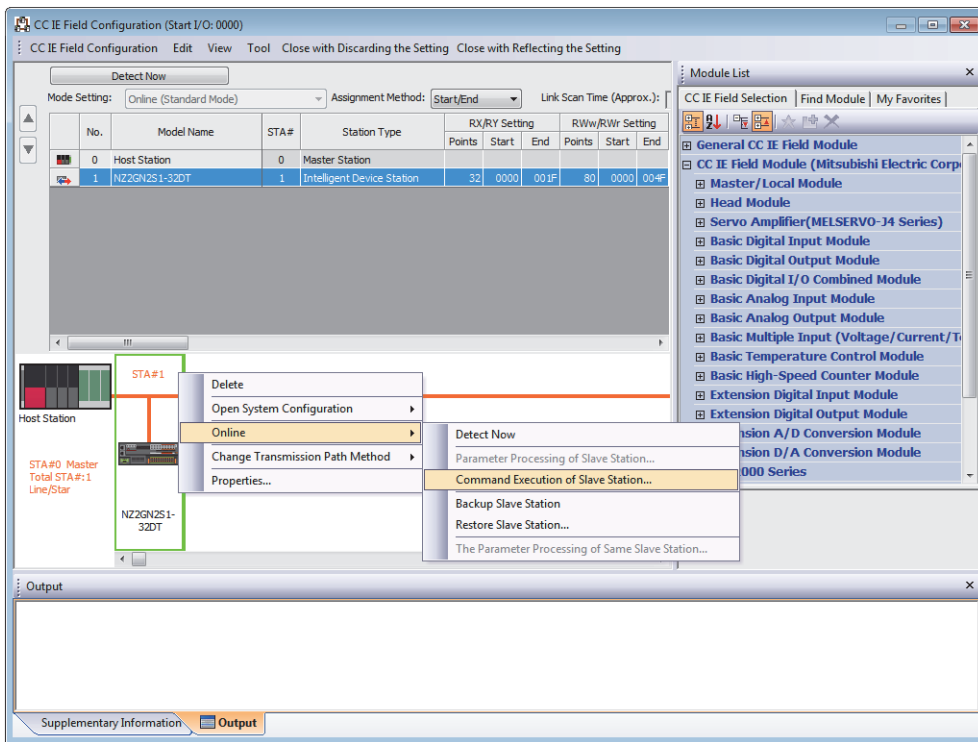

3. Set "Method selection" to "Error history read" and click the [Execute] button.

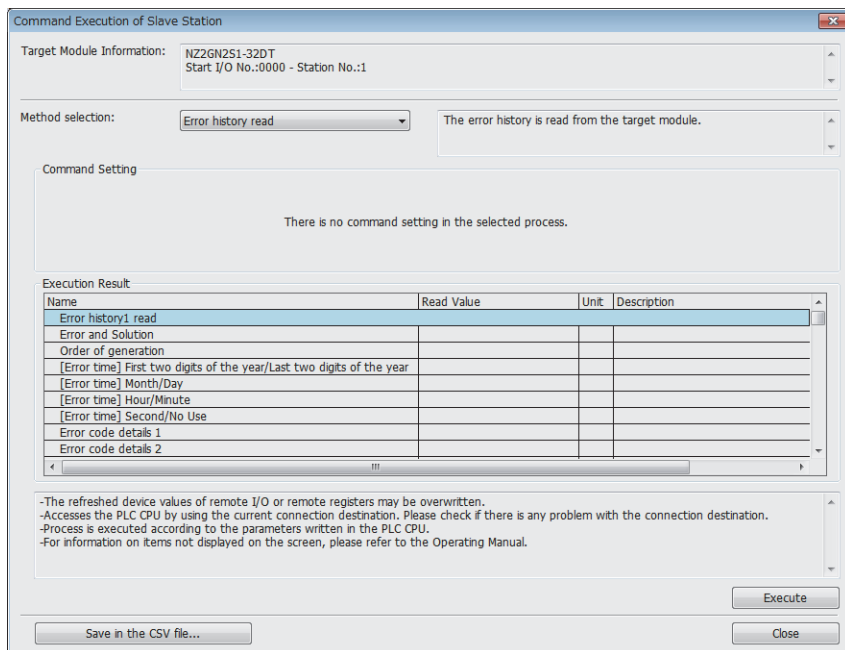

4. When the following windows appear, click the [Yes] button.

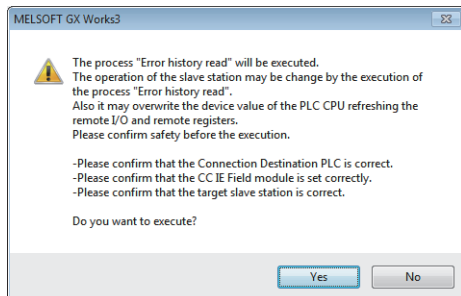
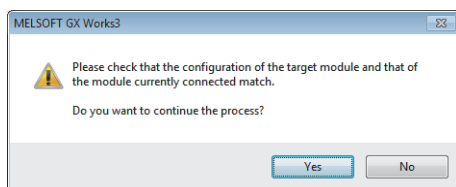

5. When the following window appears, click the [OK] button.

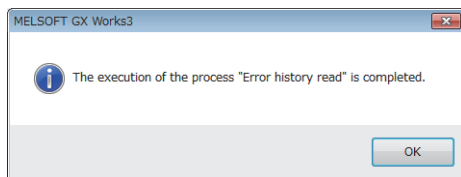

6. The error history of the I/O module is displayed in "Execution Result".

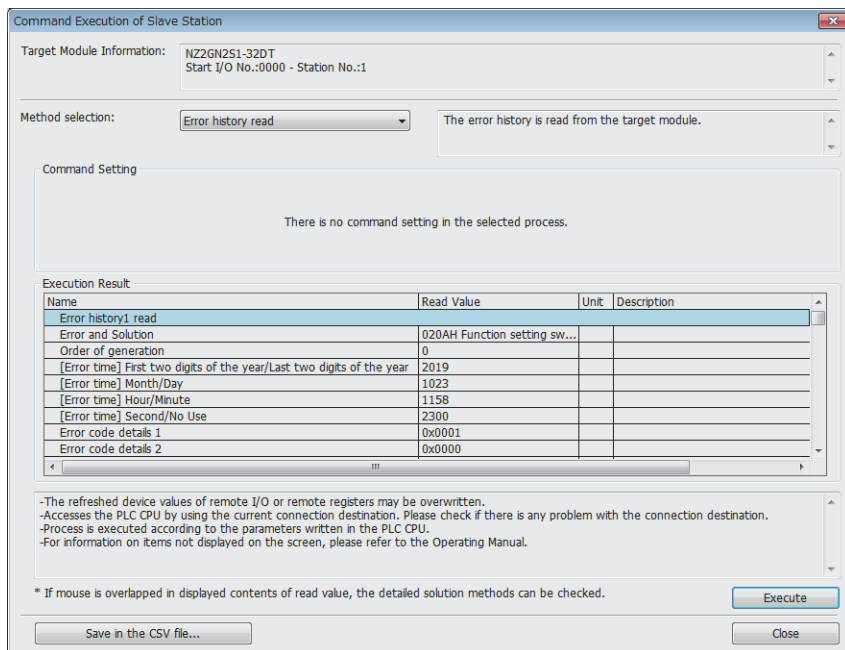

To initialize the error history, set "Method selection" to "Error history clear request" on the "Command Execution of Slave Station" window and click the [Execute] button.

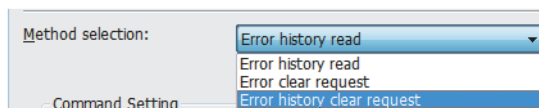

11.7 Error Code List

The error codes are classified into the following three types.

Classification	Description
Major error	An error that cannot be recovered. The RUN LED turns off.
Moderate error	An error where the module cannot continue to operate. The ERR. LED turns on.
Minor error	An error where the module can continue to operate. The ERR. LED flashes.

I/O module error codes are as follows.

Error code	Error type	Error name	Description and cause	Action
0010H	Major error	Hardware error	Module hardware error	Power off and on the module power supply. If this error occurs again, the possible cause is a module failure. Please consult your local Mitsubishi representative.
0100H	Moderate error	RWw/RWr setting error	When "Network Synchronous Communication" in the network configuration settings is set to "Synchronous", System area (RWw3/RWr3) is not set in "RWw/RWr Setting".	Correct the RWw/RWr setting of the network configuration setting to assign the System area (RWw3/RWr3), and turn off and on the module power supply or perform remote reset.
0101H	Moderate error	Synchronization cycle setting error	The synchronization cycle set in the master station is not supported by the I/O module.	Check the synchronization cycle of the master station, and then turn off and on the power supply of the I/O module or perform remote reset.
0102H	Moderate error	Synchronous communication error 1	Synchronous communication with the master station has failed for a certain period of time.	Take any of the following actions, and then turn off and on the power supply of the I/O module or perform remote reset. <ul style="list-style-type: none"> For the synchronization cycle setting for the master station, set a long cycle. Reduce the number of slave stations operating with the CC-Link IE Field Network synchronous communication function. Take measures against noise on the transmission path.
0103H	Moderate error	Synchronous communication error 2	Synchronous communication with the master station has failed for a certain period of time.	Take measures against noise on the transmission path, and then turn off and on the module power supply of I/O module, or perform remote reset.
0104H	Moderate error	External power supply OFF error	The external power supply voltage turns off.	<ul style="list-style-type: none"> Check the state of the external power supply. Check if the power supply voltage satisfies the specifications for the I/O module. Correct the timing of turning on or off External power supply monitor request (RWw2.b9) if an error occurs when starting or stopping the system.
0106H	Moderate error	IP address/station number setting switch out of range error	The IP address/station number setting switches are set outside the range of 1 to 120.	Turn on the power supply with the IP address/station number setting switches set to a value in the range 1 to 120.
0107H	Moderate error	MODE switch incorrect	The MODE switch is set to an incorrect state.	Set the MODE switch correctly.
0200H	Minor error	IP address/station number setting switch changed error	An IP address/station number setting switch has been changed with the module power supply on.	Return the IP address/station number setting switch to the setting it had when the module was powered on.
0201H	Minor error	Function setting switch 1 changed error	The function setting switch 1 has been changed with the module power supply on.	Return the function setting switch 1 to the setting when the module power supply was on.
0202H	Minor error	Function setting switch 2 changed error	The function setting switch 2 has been changed with the module power supply on.	Return the function setting switch 2 to the setting when the module power supply was on.
0203H	Minor error	Function setting switch 3 changed error	The function setting switch 3 has been changed with the module power supply on.	Return the function setting switch 3 to the setting when the module power supply was on.
0204H	Minor error	Function setting switch 4 changed error	The function setting switch 4 has been changed with the module power supply on.	Return the function setting switch 4 to the setting when the module power supply was on.
0205H	Minor error	Function setting switch 5 changed error	The function setting switch 5 has been changed with the module power supply on.	Return the function setting switch 5 to the setting when the module power supply was on.

Error code	Error type	Error name	Description and cause	Action
0206H	Minor error	Function setting switch 6 changed error	The function setting switch 6 has been changed with the module power supply on.	Return the function setting switch 6 to the setting when the module power supply was on.
0207H	Minor error	Function setting switch 7 changed error	The function setting switch 7 has been changed with the module power supply on.	Return the function setting switch 7 to the setting when the module power supply was on.
0208H	Minor error	Function setting switch 8 changed error	The function setting switch 8 has been changed with the module power supply on.	Return the function setting switch 8 to the setting when the module power supply was on.
0209H	Minor error	Function setting switch 9 changed error	The function setting switch 9 has been changed with the module power supply on.	Return the function setting switch 9 to the setting when the module power supply was on.
020AH	Minor error	Function setting switch 10 changed error	The function setting switch 10 has been changed with the module power supply on.	Return the function setting switch 10 to the setting when the module power supply was on.
0220H	Minor error	Error history save limit error	The upper limit for the number of times an error is saved in the error history is reached.	No more errors can be saved in the error history. Check the error by the latest error code.
0240H	Minor error	Module power supply voltage drop error	The module power supply voltage is dropped.	<ul style="list-style-type: none"> • Check the state of the module power supply. • Check if the power supply voltage satisfies the specifications for the I/O module.
0251H	Minor error	Non-volatile memory access error (error history)	The error cannot be saved because an error in access to the non-volatile memory was detected.	<ul style="list-style-type: none"> • An error that occurred at the time of or before this error may not be saved into the non-volatile memory. • Take measures against noise with a shielded cable for connection. • If this error occurs again, the possible cause is a module failure. Please consult your local Mitsubishi representative.
0260H	Minor error	Remote buffer memory access error	An area other than the remote buffer memory areas has been accessed using the REMFR/REMTO/REMFDR/REMTOD instruction.	Correct the setting data of the REMFR/REMTO/REMFDR/REMTOD instruction to access the remote buffer memory area range.
0261H	Minor error	Incorrect network parameter access error	I/O module was accessed when network parameter was in the incorrect status.	Set network parameter again correctly.
0270H	Minor error	Remote reset disable error	Remote reset could not be performed because the setting of the NETWORK switch is different from the setting it had when the module was powered on.	Return the NETWORK switch to the setting it had when the module was powered on, and then perform remote reset again.
D0E2H	Communication error	Station number in use (own station)	The setting of the IP address/station number setting switches is incorrect.	Set a unique station number. After taking the above action, turn off and on or reset all the stations where this error has been detected.
D0E3H	Communication error	Own station No. out of range	The network parameter is incorrect or outside the range.	Add the station information of the module in the network configuration settings of the master station (submaster station).
D217H	Communication error	Transient data request command error	The transient data request command is incorrect.	Correct the request command at the transient request source, and retry the operation.
D2A0H	Communication error	Receive buffer full	The target station is overloaded and cannot receive transient data.	<ul style="list-style-type: none"> • Check the network status using the CC-Link IE TSN/CC-Link IE Field diagnostics of the engineering tool, and take corrective action. • When the target station is overloaded and cannot receive transient data, send the data from the send source after some time has passed.
D2A3H	Communication error	Transient data length error	The received transient data is incorrect.	Correct the amount of data (frame length) at the transient request source, and retry the operation.
DF01H	Communication error	Transient data divided error	Divided transient data has been received.	Send the transient data that is not divided.

APPENDICES

Appendix 1 Remote I/O Signal

List of remote I/O signals

I/O signals for a master/local module are listed as follows.

The I/O signals in this section are the examples with the start of remote I/O signals of the I/O module assigned to the device number of RX0 and RY0.

Remote input (RX) indicates the input signal from the I/O module to the master/local module.

Remote output (RY) indicates the output signal from the master/local module to the I/O module.

Point

Do not use any "Use prohibited" remote I/O signals. Doing so may result in an accident due to an incorrect output or malfunction.

Input module (16-point module)

■ Remote input signal

Device number	Name
RX0	External input signal X0
RX1	External input signal X1
RX2	External input signal X2
RX3	External input signal X3
RX4	External input signal X4
RX5	External input signal X5
RX6	External input signal X6
RX7	External input signal X7
RX8	External input signal X8
RX9	External input signal X9
RXA	External input signal XA
RXB	External input signal XB
RXC	External input signal XC
RXD	External input signal XD
RXE	External input signal XE
RXF	External input signal XF

■ Remote output signal

Device number	Name
RY0 to RYF	Use prohibited

Input module (32-point module)

■ Remote input signal

Device number	Name
RX0	External input signal X0
RX1	External input signal X1
RX2	External input signal X2
RX3	External input signal X3
RX4	External input signal X4
RX5	External input signal X5
RX6	External input signal X6
RX7	External input signal X7
RX8	External input signal X8
RX9	External input signal X9
RXA	External input signal XA
RXB	External input signal XB
RXC	External input signal XC
RXD	External input signal XD
RXE	External input signal XE
RXF	External input signal XF
RX10	External input signal X10
RX11	External input signal X11
RX12	External input signal X12
RX13	External input signal X13
RX14	External input signal X14
RX15	External input signal X15
RX16	External input signal X16
RX17	External input signal X17
RX18	External input signal X18
RX19	External input signal X19
RX1A	External input signal X1A
RX1B	External input signal X1B
RX1C	External input signal X1C
RX1D	External input signal X1D
RX1E	External input signal X1E
RX1F	External input signal X1F

■ Remote output signal

Device number	Name
RY0 to RY1F	Use prohibited

Output module (16-point module)

■ Remote input signal

Device number	Name
RX0 to RXF	Use prohibited

■ Remote output signal

Device number	Name
RY0	External output signal Y0
RY1	External output signal Y1
RY2	External output signal Y2
RY3	External output signal Y3
RY4	External output signal Y4
RY5	External output signal Y5
RY6	External output signal Y6
RY7	External output signal Y7
RY8	External output signal Y8
RY9	External output signal Y9
RYA	External output signal YA
RYB	External output signal YB
RYC	External output signal YC
RYD	External output signal YD
RYE	External output signal YE
RYF	External output signal YF

Output module (32-point module)

■ Remote input signal

Device number	Name
RX0 to RX1F	Use prohibited

■ Remote output signal

Device number	Name
RY0	External output signal Y0
RY1	External output signal Y1
RY2	External output signal Y2
RY3	External output signal Y3
RY4	External output signal Y4
RY5	External output signal Y5
RY6	External output signal Y6
RY7	External output signal Y7
RY8	External output signal Y8
RY9	External output signal Y9
RYA	External output signal YA
RYB	External output signal YB
RYC	External output signal YC
RYD	External output signal YD
RYE	External output signal YE
RYF	External output signal YF
RY10	External output signal Y10
RY11	External output signal Y11
RY12	External output signal Y12
RY13	External output signal Y13
RY14	External output signal Y14
RY15	External output signal Y15
RY16	External output signal Y16
RY17	External output signal Y17
RY18	External output signal Y18
RY19	External output signal Y19
RY1A	External output signal Y1A
RY1B	External output signal Y1B
RY1C	External output signal Y1C
RY1D	External output signal Y1D
RY1E	External output signal Y1E
RY1F	External output signal Y1F

I/O combined module (16-point module)

■ Remote input signal

Device number	Name
RX0	External input signal X0
RX1	External input signal X1
RX2	External input signal X2
RX3	External input signal X3
RX4	External input signal X4
RX5	External input signal X5
RX6	External input signal X6
RX7	External input signal X7
RX8 to RXF	Use prohibited

■ Remote output signal

Device number	Name
RY0 to RY7	Use prohibited
RY8	External output signal Y8
RY9	External output signal Y9
RYA	External output signal YA
RYB	External output signal YB
RYC	External output signal YC
RYD	External output signal YD
RYE	External output signal YE
RYF	External output signal YF

I/O combined module (32-point module)

■ Remote input signal

Device number	Name
RX0	External input signal X0
RX1	External input signal X1
RX2	External input signal X2
RX3	External input signal X3
RX4	External input signal X4
RX5	External input signal X5
RX6	External input signal X6
RX7	External input signal X7
RX8	External input signal X8
RX9	External input signal X9
RXA	External input signal XA
RXB	External input signal XB
RXC	External input signal XC
RXD	External input signal XD
RXE	External input signal XE
RXF	External input signal XF
RX10 to RX1F	Use prohibited

■ Remote output signal

Device number	Name
RY0 to RYF	Use prohibited
RY10	External output signal Y10
RY11	External output signal Y11
RY12	External output signal Y12
RY13	External output signal Y13
RY14	External output signal Y14
RY15	External output signal Y15
RY16	External output signal Y16
RY17	External output signal Y17
RY18	External output signal Y18
RY19	External output signal Y19
RY1A	External output signal Y1A
RY1B	External output signal Y1B
RY1C	External output signal Y1C
RY1D	External output signal Y1D
RY1E	External output signal Y1E
RY1F	External output signal Y1F

Details of remote input signals

The following describes the details of the remote input signals for the master/local module.

External input signal

■Device number

Name	Device number
External input signal X0 to external input signal X1F	RX0 to RX1F

■Description

This signal shows the on/off status of the external input of input module and I/O combined module.



When a major or moderate error occurs in the I/O module, the external input signal turns off.

Details of remote output signals

The following describes the details of the remote output signals for the master/local module.

External output signal

■Device number

Name	Device number
External output signal Y0 to external output signal Y1F	RY0 to RY1F

■Description

This signal turns on/off the external output of output module and I/O combined module.



When a major or moderate error occurs in the I/O module, external output turns off, regardless of the status of the external output signal.

In addition, when either of the following conditions is applied, due to the output HOLD/CLEAR setting function, external output may operate differently than the status of the external output signal.

- The I/O module is disconnected from the data link.
- The operation status of the CPU module is STOP or it is suspended by an error.

For details on the output HOLD/CLEAR setting function, refer to the following.

Page 153 Output HOLD/CLEAR Setting Function

Appendix 2 Remote Register

List of remote registers

This section lists remote registers for a master/local module.

The remote registers shown are the examples with the start of remote registers of the I/O module assigned to the device number of RWr0 and RWw0.

Remote register (RWr) is the information input from the I/O module to the master/local module.

Remote register (RWw) is the information output from the master/local module to the I/O module.

Input module (16-point module)

■Remote register (RWr)

Device number	Name		
	CC-Link IE Field Network synchronous communication function		
	Not used	Synchronous X/Y control mode	Synchronization cycle timing control mode
RWr0	Module status area	Module status area	Module status area
RWr1	Error code	Error code	Error code
RWr2	Function selection status area	Function selection status area	Function selection status area
RWr3	Use prohibited	Use prohibited ^{*1}	Use prohibited ^{*1}
RWr4 to RWrF	Use prohibited	Use prohibited	Use prohibited
RWr10	Use prohibited	Use prohibited	Synchronization input timing information X0 OFF to ON
RWr11	Use prohibited	Use prohibited	Synchronization input timing information X0 ON to OFF
⋮	⋮		
RWr2E	Use prohibited	Use prohibited	Synchronization input timing information XF OFF to ON
RWr2F	Use prohibited	Use prohibited	Synchronization input timing information XF ON to OFF

*1 The area is used for the system.

■Remote register (RWw)

Device number	Name		
	CC-Link IE Field Network synchronous communication function		
	Not used	Synchronous X/Y control mode	Synchronization cycle timing control mode
RWw0	Module operation area	Module operation area	Module operation area
RWw1 to RWw2	Use prohibited	Use prohibited	Use prohibited
RWw3	Use prohibited	Use prohibited ^{*1}	Use prohibited ^{*1}
RWw4 to RWw2F	Use prohibited	Use prohibited	Use prohibited

*1 The area is used for the system.

Input module (32-point module)

■ Remote register (RWr)

Device number	Name		
	CC-Link IE Field Network synchronous communication function		
	Not used	Synchronous X/Y control mode	Synchronization cycle timing control mode
RWr0	Module status area	Module status area	Module status area
RWr1	Error code	Error code	Error code
RWr2	Function selection status area	Function selection status area	Function selection status area
RWr3	Use prohibited	Use prohibited ^{*1}	Use prohibited ^{*1}
RWr4 to RWrF	Use prohibited	Use prohibited	Use prohibited
RWr10	Use prohibited	Use prohibited	Synchronization input timing information X0 OFF to ON
RWr11	Use prohibited	Use prohibited	Synchronization input timing information X0 ON to OFF
⋮	⋮		
RWr4E	Use prohibited	Use prohibited	Synchronization input timing information X1F OFF to ON
RWr4F	Use prohibited	Use prohibited	Synchronization input timing information X1F ON to OFF

*1 The area is used for the system.

■ Remote register (RWw)

Device number	Name		
	CC-Link IE Field Network synchronous communication function		
	Not used	Synchronous X/Y control mode	Synchronization cycle timing control mode
RWw0	Module operation area	Module operation area	Module operation area
RWw1 to RWw2	Use prohibited	Use prohibited	Use prohibited
RWw3	Use prohibited	Use prohibited ^{*1}	Use prohibited ^{*1}
RWw4 to RWw4F	Use prohibited	Use prohibited	Use prohibited

*1 The area is used for the system.

Output module (16-point module)

■Remote register (RWr)

Device number	Name		
	CC-Link IE Field Network synchronous communication function		
	Not used	Synchronous X/Y control mode	Synchronization cycle timing control mode
RWr0	Module status area	Module status area	Module status area
RWr1	Error code	Error code	Error code
RWr2	Function selection status area	Function selection status area	Function selection status area
RWr3	Use prohibited	Use prohibited ^{*1}	Use prohibited ^{*1}
RWr4 to RWr9	Use prohibited	Use prohibited	Use prohibited
RWrA	Output Y current value Y0 to YF	Output Y current value Y0 to YF	Output Y current value Y0 to YF
RWrB	Use prohibited	Use prohibited	Use prohibited
RWrC	Output Y ON information Y0 to YF	Output Y ON information Y0 to YF	Output Y ON information Y0 to YF
RWrD	Use prohibited	Use prohibited	Use prohibited
RWrE	Output Y OFF information Y0 to YF	Output Y OFF information Y0 to YF	Output Y OFF information Y0 to YF
RWrF to RWr2F	Use prohibited	Use prohibited	Use prohibited

*1 The area is used for the system.

■Remote register (RWw)

Device number	Name		
	CC-Link IE Field Network synchronous communication function		
	Not used	Synchronous X/Y control mode	Synchronization cycle timing control mode
RWw0	Module operation area	Module operation area	Module operation area
RWw1	Use prohibited	Use prohibited	Use prohibited
RWw2	Function selection setting area	Function selection setting area	Function selection setting area
RWw3	Use prohibited	Use prohibited ^{*1}	Use prohibited ^{*1}
RWw4 to RWwB	Use prohibited	Use prohibited	Use prohibited
RWwC	Output Y ON information clear request Y0 to YF	Output Y ON information clear request Y0 to YF	Output Y ON information clear request Y0 to YF
RWwD	Use prohibited	Use prohibited	Use prohibited
RWwE	Output Y OFF information clear request Y0 to YF	Output Y OFF information clear request Y0 to YF	Output Y OFF information clear request Y0 to YF
RWwF	Use prohibited	Use prohibited	Use prohibited
RWw10	Use prohibited	Use prohibited	Synchronization output timing setting Y0 OFF to ON
RWw11	Use prohibited	Use prohibited	Synchronization output timing setting Y0 ON to OFF
⋮	⋮		
RWw2E	Use prohibited	Use prohibited	Synchronization output timing setting YF OFF to ON
RWw2F	Use prohibited	Use prohibited	Synchronization output timing setting YF ON to OFF

*1 The area is used for the system.

Output module (32-point module)

■Remote register (RWr)

Device number	Name		
	CC-Link IE Field Network synchronous communication function		
	Not used	Synchronous X/Y control mode	Synchronization cycle timing control mode
RWr0	Module status area	Module status area	Module status area
RWr1	Error code	Error code	Error code
RWr2	Function selection status area	Function selection status area	Function selection status area
RWr3	Use prohibited	Use prohibited ^{*1}	Use prohibited ^{*1}
RWr4 to RWr9	Use prohibited	Use prohibited	Use prohibited
RWrA	Output Y current value Y0 to YF	Output Y current value Y0 to YF	Output Y current value Y0 to YF
RWrB	Output Y current value Y10 to Y1F	Output Y current value Y10 to Y1F	Output Y current value Y10 to Y1F
RWrC	Output Y ON information Y0 to YF	Output Y ON information Y0 to YF	Output Y ON information Y0 to YF
RWrD	Output Y ON information Y10 to Y1F	Output Y ON information Y10 to Y1F	Output Y ON information Y10 to Y1F
RWrE	Output Y OFF information Y0 to YF	Output Y OFF information Y0 to YF	Output Y OFF information Y0 to YF
RWrF	Output Y OFF information Y10 to Y1F	Output Y OFF information Y10 to Y1F	Output Y OFF information Y10 to Y1F
RWr10 to RWr4F	Use prohibited	Use prohibited	Use prohibited

*1 The area is used for the system.

■Remote register (RWw)

Device number	Name		
	CC-Link IE Field Network synchronous communication function		
	Not used	Synchronous X/Y control mode	Synchronization cycle timing control mode
RWw0	Module operation area	Module operation area	Module operation area
RWw1	Use prohibited	Use prohibited	Use prohibited
RWw2	Function selection setting area	Function selection setting area	Function selection setting area
RWw3	Use prohibited	Use prohibited ^{*1}	Use prohibited ^{*1}
RWw4 to RWwB	Use prohibited	Use prohibited	Use prohibited
RWwC	Output Y ON information clear request Y0 to YF	Output Y ON information clear request Y0 to YF	Output Y ON information clear request Y0 to YF
RWwD	Output Y ON information clear request Y10 to Y1F	Output Y ON information clear request Y10 to Y1F	Output Y ON information clear request Y10 to Y1F
RWwE	Output Y OFF information clear request Y0 to YF	Output Y OFF information clear request Y0 to YF	Output Y OFF information clear request Y0 to YF
RWwF	Output Y OFF information clear request Y10 to Y1F	Output Y OFF information clear request Y10 to Y1F	Output Y OFF information clear request Y10 to Y1F
RWw10	Use prohibited	Use prohibited	Synchronization output timing setting Y0 OFF to ON
RWw11	Use prohibited	Use prohibited	Synchronization output timing setting Y0 ON to OFF
⋮	⋮		
RWw4E	Use prohibited	Use prohibited	Synchronization output timing setting Y1F OFF to ON
RWw4F	Use prohibited	Use prohibited	Synchronization output timing setting Y1F ON to OFF

*1 The area is used for the system.

A

I/O combined module (16-point module)

■Remote register (RWr)

Device number	Name		
	CC-Link IE Field Network synchronous communication function		
	Not used	Synchronous X/Y control mode	Synchronization cycle timing control mode
RWr0	Module status area	Module status area	Module status area
RWr1	Error code	Error code	Error code
RWr2	Function selection status area	Function selection status area	Function selection status area
RWr3	Use prohibited	Use prohibited ^{*1}	Use prohibited ^{*1}
RWr4 to RWr9	Use prohibited	Use prohibited	Use prohibited
RWrA	Output Y current value Y8 to Y1F	Output Y current value Y8 to Y1F	Output Y current value Y8 to Y1F
RWrB	Use prohibited	Use prohibited	Use prohibited
RWrC	Output Y ON information Y8 to Y1F	Output Y ON information Y8 to Y1F	Output Y ON information Y8 to Y1F
RWrD	Use prohibited	Use prohibited	Use prohibited
RWrE	Output Y OFF information Y8 to Y1F	Output Y OFF information Y8 to Y1F	Output Y OFF information Y8 to Y1F
RWrF	Use prohibited	Use prohibited	Use prohibited
RWr10	Use prohibited	Use prohibited	Synchronization input timing information X0 OFF to ON
RWr11	Use prohibited	Use prohibited	Synchronization input timing information X0 ON to OFF
⋮	⋮		
RWr1E	Use prohibited	Use prohibited	Synchronization input timing information X7 OFF to ON
RWr1F	Use prohibited	Use prohibited	Synchronization input timing information X7 ON to OFF
RWr20 to RWr2F	Use prohibited	Use prohibited	Use prohibited

*1 The area is used for the system.

■Remote register (RWw)

Device number	Name		
	CC-Link IE Field Network synchronous communication function		
	Not used	Synchronous X/Y control mode	Synchronization cycle timing control mode
RWw0	Module operation area	Module operation area	Module operation area
RWw1	Use prohibited	Use prohibited	Use prohibited
RWw2	Function selection setting area	Function selection setting area	Function selection setting area
RWw3	Use prohibited	Use prohibited ^{*1}	Use prohibited ^{*1}
RWw4 to RWwB	Use prohibited	Use prohibited	Use prohibited
RWwC	Output Y ON information clear request Y8 to YF	Output Y ON information clear request Y8 to YF	Output Y ON information clear request Y8 to YF
RWwD	Use prohibited	Use prohibited	Use prohibited
RWwE	Output Y OFF information clear request Y8 to YF	Output Y OFF information clear request Y8 to YF	Output Y OFF information clear request Y8 to YF
RWwF to RWw1F	Use prohibited	Use prohibited	Use prohibited
RWw20	Use prohibited	Use prohibited	Synchronization output timing setting Y8 OFF to ON
RWw21	Use prohibited	Use prohibited	Synchronization output timing setting Y8 ON to OFF
⋮	⋮		
RWw2E	Use prohibited	Use prohibited	Synchronization output timing setting YF OFF to ON
RWw2F	Use prohibited	Use prohibited	Synchronization output timing setting YF ON to OFF

*1 The area is used for the system.

I/O combined module (32-point module)

■Remote register (RWr)

Device number	Name		
	CC-Link IE Field Network synchronous communication function		
	Not used	Synchronous X/Y control mode	Synchronization cycle timing control mode
RWr0	Module status area	Module status area	Module status area
RWr1	Error code	Error code	Error code
RWr2	Function selection status area	Function selection status area	Function selection status area
RWr3	Use prohibited	Use prohibited ^{*1}	Use prohibited ^{*1}
RWr4 to RWrA	Use prohibited	Use prohibited	Use prohibited
RWrB	Output Y current value Y10 to Y1F	Output Y current value Y10 to Y1F	Output Y current value Y10 to Y1F
RWrC	Use prohibited	Use prohibited	Use prohibited
RWrD	Output Y ON information Y10 to Y1F	Output Y ON information Y10 to Y1F	Output Y ON information Y10 to Y1F
RWrE	Use prohibited	Use prohibited	Use prohibited
RWrF	Output Y OFF information Y10 to Y1F	Output Y OFF information Y10 to Y1F	Output Y OFF information Y10 to Y1F
RWr10	Use prohibited	Use prohibited	Synchronization input timing information X0 OFF to ON
RWr11	Use prohibited	Use prohibited	Synchronization input timing information X0 ON to OFF
⋮	⋮		
RWr2E	Use prohibited	Use prohibited	Synchronization input timing information XF OFF to ON
RWr2F	Use prohibited	Use prohibited	Synchronization input timing information XF ON to OFF
RWr30 to RWr4F	Use prohibited	Use prohibited	Use prohibited

*1 The area is used for the system.

■Remote register (RWw)

Device number	Name		
	CC-Link IE Field Network synchronous communication function		
	Not used	Synchronous X/Y control mode	Synchronization cycle timing control mode
RWw0	Module operation area	Module operation area	Module operation area
RWw1	Use prohibited	Use prohibited	Use prohibited
RWw2	Function selection setting area	Function selection setting area	Function selection setting area
RWw3	Use prohibited	Use prohibited ^{*1}	Use prohibited ^{*1}
RWw4 to RWwC	Use prohibited	Use prohibited	Use prohibited
RWwD	Output Y ON information clear request Y10 to Y1F	Output Y ON information clear request Y10 to Y1F	Output Y ON information clear request Y10 to Y1F
RWwE	Use prohibited	Use prohibited	Use prohibited
RWwF	Output Y OFF information clear request Y10 to Y1F	Output Y OFF information clear request Y10 to Y1F	Output Y OFF information clear request Y10 to Y1F
RWw10 to RWw2F	Use prohibited	Use prohibited	Use prohibited
RWw30	Use prohibited	Use prohibited	Synchronization output timing setting Y10 OFF to ON
RWw31	Use prohibited	Use prohibited	Synchronization output timing setting Y10 ON to OFF
⋮	⋮		
RWw4E	Use prohibited	Use prohibited	Synchronization output timing setting Y1F OFF to ON
RWw4F	Use prohibited	Use prohibited	Synchronization output timing setting Y1F ON to OFF

*1 The area is used for the system.

A

Details of remote registers

Module status area

■Device number

Name	Device number
Module status area	RWr0

■Description

This area is intended for module status checking.

RWr0	Name
b0 to b9	Use prohibited
b10	Error flag
b11 to b15	Use prohibited

■Error flag (RWr0.b10)

Turning on Error clear request flag (RWw0.b10) after eliminating the cause of the error changes the error code (RWr1) to 0.

Some error cannot be cleared with Error clear request flag (RWw0.b10) depending on its details.

- Operation in the event of a minor error

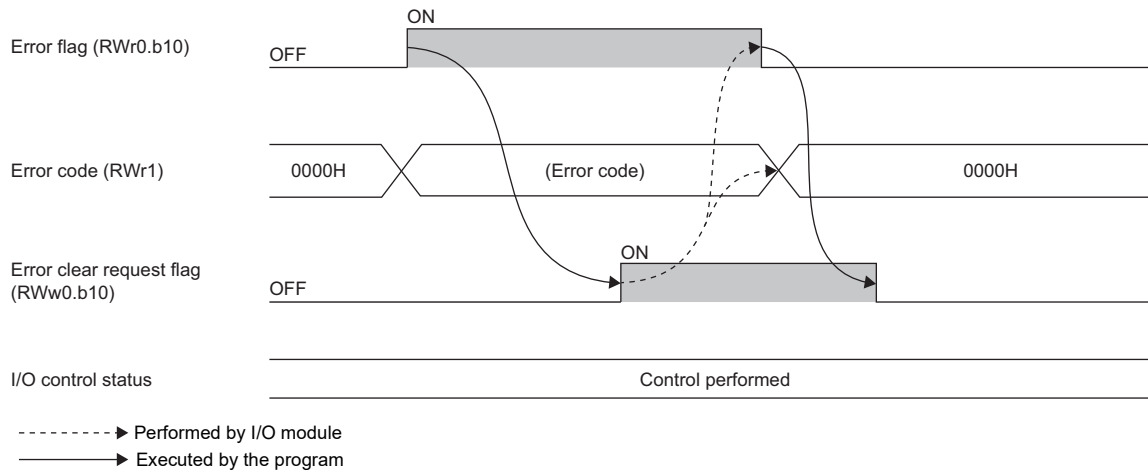

- Operation in the event of a moderate error

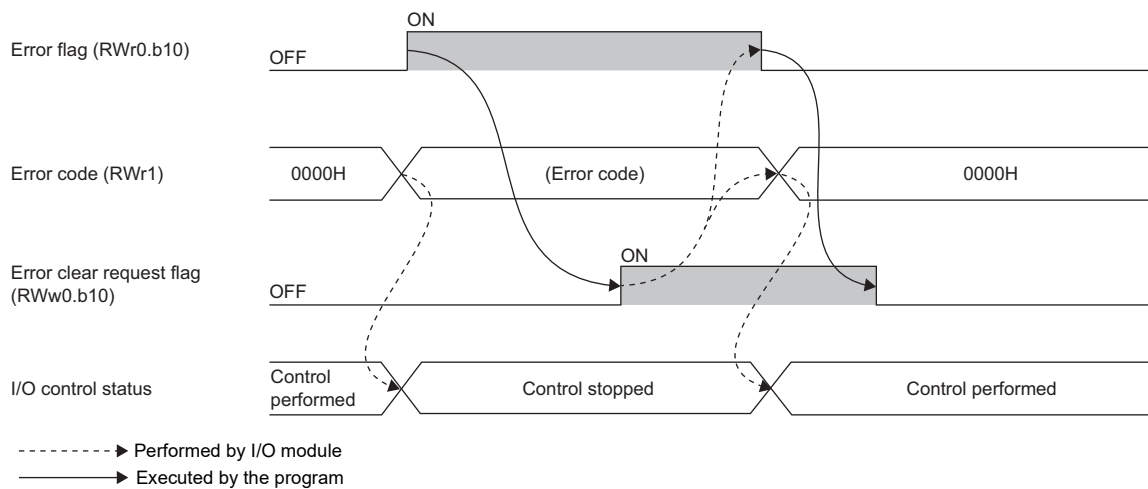

Error code

■Device number

Name	Device number
Error code	RWr1

■Description

The error code is stored. (🔍 Page 211 Error Code List)

Point

When multiple errors have occurred, these errors are stored in the error code (RWr1) in the following priority.

- When the error type differs, they are stored in the order of major error > moderate error > minor error.
- When the error type is the same, the error that occurred later is stored.
- Communication errors are not stored.

■Method for clearing an error

The method for clearing an error depends on the error type.

Error type	Clearing an error
Major error	The error cannot be cleared.
Moderate error	Eliminate the error cause, and power off and on the I/O module. Or, turn on and off Error clear request flag (RWw0.b10).
Minor error	Eliminate the error cause, and power off and on the I/O module. Or, turn on and off Error clear request flag (RWw0.b10).
Communication error	Eliminate the error cause. The error does not need to be cleared.

Point

Communication errors are not stored in the error code, but stored only in the error history.

Function selection status area

■Device number

Name	Device number
Function selection status area	RWr2

■Description

The setting status of the function is shown.

Function selection status area			
RWr2	Input module	Output module	I/O combined module
b0 to b2	Input response setting status	Use prohibited	Input response setting status
b3	Use prohibited	Output HOLD/CLEAR setting status	Output HOLD/CLEAR setting status
b4, b5	CC-Link IE Field Network synchronous communication setting status	CC-Link IE Field Network synchronous communication setting status	CC-Link IE Field Network synchronous communication setting status
b6	Fast link-up setting status (PORT1)	Fast link-up setting status (PORT1)	Fast link-up setting status (PORT1)
b7	Fast link-up setting status (PORT2)	Fast link-up setting status (PORT2)	Fast link-up setting status (PORT2)
b8	Use prohibited	Use prohibited	Use prohibited
b9	Use prohibited	External power supply monitor status	External power supply monitor status
b10 to b15	Use prohibited	Use prohibited	Use prohibited

■Input response setting status (RWr2.b0 to RWr2.b2)

The setting status of the input response setting function is shown.

Value in RWr2.b2	Value in RWr2.b1	Value in RWr2.b0	Setting status
Off	Off	Off	1ms
Off	Off	On	0ms
Off	On	Off	0.2ms
Off	On	On	1.5ms
On	Off	Off	5ms
On	Off	On	10ms
On	On	Off	20ms
On	On	On	70ms

■Output HOLD/CLEAR setting status (RWr2.b3)

The setting status of the output HOLD/CLEAR setting function is shown.

Value for RWr2.b3	Setting status
Off	CLEAR
On	HOLD

■CC-Link IE Field Network synchronous communication setting status (RWr2.b4, RWr2.b5)

The setting status of the CC-Link IE Field Network synchronous communication function is shown.

Value for RWr2.b5	Value for RWr2.b4	Network Synchronous Communication	Operation mode
Off	Off	Asynchronous	—
Off	On	Synchronous	Synchronous X/Y control mode
On	Off	Synchronous	Synchronization cycle timing control mode
On	On	Asynchronous	—

■Fast link-up setting status (PORT1) (RWr2.b6)

The setting status of the fast link-up setting status (PORT1) is shown.

Value for RWr2.b6	Setting status
Off	Disable
On	Enable

■Fast link-up setting status (PORT2) (RWr2.b7)

The setting status of the fast link-up setting status (PORT2) is shown.

Value for RWr2.b7	Setting status
Off	Disable
On	Enable

■External power supply monitor status (RWr2.b9)

The setting status of the external power supply monitoring function is shown.

Value for RWr2.b9	Setting status
Off	Disable
On	Enable

Output Y current value

■Device number

Name	Device number
Output Y current value	RWrA, RWrB

■Description

- Actual on/off status of output Y can be checked by using Output Y current value Y□ (RWrA, RWrB).
- The amount of time delay from when Output Y current value Y□ (RWrA, RWrB) changes until the external output accordingly changes is no more than the maximum output response time.

■Output Y current value Y0 to YF (RWrA)

b15	b14	b13	b12	b11	b10	b9	b8	b7	b6	b5	b4	b3	b2	b1	b0
YF	YE	YD	YC	YB	YA	Y9	Y8	Y7	Y6	Y5	Y4	Y3	Y2	Y1	Y0

Off: Output Y is off.

On: Output Y is on.

■Output Y current value Y10 to Y1F (RWrB)

b15	b14	b13	b12	b11	b10	b9	b8	b7	b6	b5	b4	b3	b2	b1	b0
Y1F	Y1E	Y1D	Y1C	Y1B	Y1A	Y19	Y18	Y17	Y16	Y15	Y14	Y13	Y12	Y11	Y10

Off: Output Y is off.

On: Output Y is on.

Output Y ON information

■Device number

Name	Device number
Output Y ON information	RWrC, RWrD

■Description

Whether output Y has been turned on or not can be checked with Output Y ON information Y□ (RWrC, RWrD).

■Output Y ON information Y0 to YF (RWrC)

b15	b14	b13	b12	b11	b10	b9	b8	b7	b6	b5	b4	b3	b2	b1	b0
YF	YE	YD	YC	YB	YA	Y9	Y8	Y7	Y6	Y5	Y4	Y3	Y2	Y1	Y0

Off: Output Y has never been turned on.

On: Output Y has been turned on.

■Output Y ON information Y10 to Y1F (RWrD)

b15	b14	b13	b12	b11	b10	b9	b8	b7	b6	b5	b4	b3	b2	b1	b0
Y1F	Y1E	Y1D	Y1C	Y1B	Y1A	Y19	Y18	Y17	Y16	Y15	Y14	Y13	Y12	Y11	Y10

Off: Output Y has never been turned on.

On: Output Y has been turned on.

Output Y ON information Y□ (RWrC, RWrD) can be cleared using Output Y ON information clear request Y□ (RWwC, RWwD).

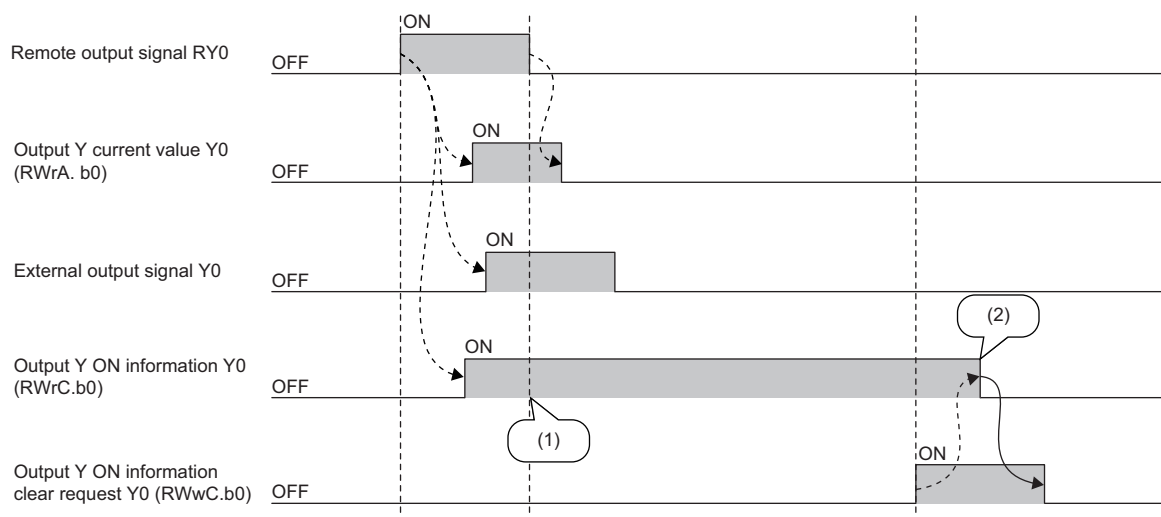

-----> Performed by I/O module

-----> Executed by the program

(1) Remains on even after Y0 turns off.

(2) Turns off when the clear request turns on.

Point

While Output Y ON information clear request is turned on, regardless of the remote output signal status, output Y ON information continues to be cleared.

Output Y OFF information

■Device number

Name	Device number
Output Y OFF information	RWrE, RWrF

■Description

Whether output Y has been turned off or not can be checked with Output Y OFF information Y□ (RWrE, RWrF).

■Output Y OFF information Y0 to YF (RWrE)

b15	b14	b13	b12	b11	b10	b9	b8	b7	b6	b5	b4	b3	b2	b1	b0
YF	YE	YD	YC	YB	YA	Y9	Y8	Y7	Y6	Y5	Y4	Y3	Y2	Y1	Y0

Off: Output Y has never been turned off.

On: Output Y has been turned off.

■Output Y OFF information Y10 to Y1F (RWrF)

b15	b14	b13	b12	b11	b10	b9	b8	b7	b6	b5	b4	b3	b2	b1	b0
Y1F	Y1E	Y1D	Y1C	Y1B	Y1A	Y19	Y18	Y17	Y16	Y15	Y14	Y13	Y12	Y11	Y10

Off: Output Y has never been turned off.

On: Output Y has been turned off.

Output Y OFF information Y□ (RWrE, RWrF) can be cleared using Output Y OFF information clear request Y□ (RWwE, RWwF).

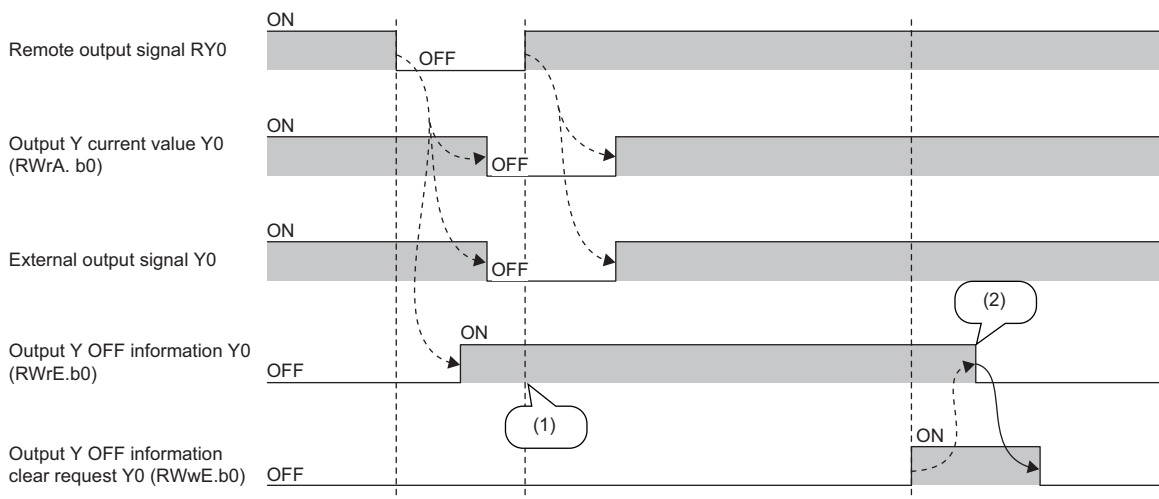

-----> Performed by I/O module

—————> Executed by the program

(1) Remains on even after Y0 turns on.

(2) Turns off when the clear request turns on.



While Output Y OFF information clear request is turned on, regardless of the remote output signal status, output Y OFF information continues to be cleared.

A

Synchronization input timing information

■Device number

Name	Device number
Synchronization input timing information X□	RWr10 to RWr4F

■Description

When the synchronization cycle timing control mode is used, the input timing relative to the synchronization cycle start timing is stored.

The time when the input has changed from OFF to ON, or from ON to OFF in one synchronization cycle is stored.

When the input has changed multiple times in one synchronization cycle, the time of first change is stored.

■Stored value

The value indicates the amount of time (unit: 0.1μs) that has passed from the synchronization cycle start timing to the input change.

The following table lists the stored values.

Stored value	Description
0 to 65534 (0000H to FFFE _H)	Shows that the input has changed at the timing of stored value.
65535 (FFFF _H)	Shows that the input has not changed within the synchronization cycle.

Module operation area

■Device number

Name	Device number
Module operation area	RWw0

■Description

This area is intended for module operation.

RWw0	Name
b0 to b9	Use prohibited
b10	Error clear request flag
b11 to b15	Use prohibited

■Error clear request flag (RWw0.b10)

For operation of the error clear request flag (RWw0.b10), refer to the following.

☞ Page 226 Error flag (RWr0.b10)

Function selection setting area

■Device number

Name	Device number
Function selection setting area	RWw2

■Description

Whether to enable or disable the function is set.

Function selection setting area			
RWw2	Input module	Output module	I/O combined module
b0 to b8	Use prohibited	Use prohibited	Use prohibited
b9		External power supply monitor request	External power supply monitor request
b10 to b15		Use prohibited	Use prohibited

■External power supply monitor request (RWw2.b9)

Whether to enable or disable the external power supply monitoring function is set.

Value for RWw2.b9	Setting
Off	Disable
On	Enable

Output Y ON information clear request

■Device number

Name	Device number
Output Y ON information clear request	RWwC, RWwD

■Description

This remote register is used to clear Output Y ON information Y□ (RWwC, RWwD). (☞ Page 167 Output ON information)

■Output Y ON information clear request Y0 to YF (RWwC)

b15	b14	b13	b12	b11	b10	b9	b8	b7	b6	b5	b4	b3	b2	b1	b0
YF	YE	YD	YC	YB	YA	Y9	Y8	Y7	Y6	Y5	Y4	Y3	Y2	Y1	Y0

Off: Output Y ON information is not cleared.

On: Output Y ON information is cleared.

■Output Y ON information clear request Y10 to Y1F (RWwD)

b15	b14	b13	b12	b11	b10	b9	b8	b7	b6	b5	b4	b3	b2	b1	b0
Y1F	Y1E	Y1D	Y1C	Y1B	Y1A	Y19	Y18	Y17	Y16	Y15	Y14	Y13	Y12	Y11	Y10

Off: Output Y ON information is not cleared.

On: Output Y ON information is cleared.

Output Y OFF information clear request

■Device number

Name	Device number
Output Y OFF information clear request	RWwE, RWwF

■Description

This remote register is used to clear Output Y OFF information Y□ (RWwE, RWwF). (☞ Page 167 Output OFF information)

■Output Y OFF information clear request Y0 to YF (RWwE)

b15	b14	b13	b12	b11	b10	b9	b8	b7	b6	b5	b4	b3	b2	b1	b0
YF	YE	YD	YC	YB	YA	Y9	Y8	Y7	Y6	Y5	Y4	Y3	Y2	Y1	Y0

Off: Output Y OFF information is not cleared.

On: Output Y OFF information is cleared.

■Output Y OFF information clear request Y10 to Y1F (RWwF)

b15	b14	b13	b12	b11	b10	b9	b8	b7	b6	b5	b4	b3	b2	b1	b0
Y1F	Y1E	Y1D	Y1C	Y1B	Y1A	Y19	Y18	Y17	Y16	Y15	Y14	Y13	Y12	Y11	Y10

Off: Output Y OFF information is not cleared.

On: Output Y OFF information is cleared.

Synchronization output timing setting

■Device number

Name	Device number
Synchronization output timing setting Y□	RWw10 to RWw4F

■Description

When the synchronization cycle timing control mode is used, set the output timing relative to the synchronization cycle start timing.

Set the timing to change the output from OFF to ON, or from ON to OFF in one synchronization cycle.

If the values set in Synchronization output timing setting Y□ OFF to ON (RWw10, RWw12, ... , RWw4C, RWw4E) and Synchronization output timing setting Y□ ON to OFF (RWw11, RWw13, ... , RWw4D, RWw4F) are the same for one output, the output does not change.

If a set value is longer than the synchronization cycle, the output also does not change.

■Setting value

Set the time (unit: 0.1μs) taken from the synchronization cycle start timing to the output change.

The following table lists the setting values.

Setting value	Description
0 to 65534 (0000H to FFFE _H)	The output changes at preset timing.
65535 (FFFF _H)	The output does not change.

Appendix 3 Remote Buffer Memory

This section describes the remote buffer memory.

The remote buffer memory consists of addresses for the error history area and module control data area.

Restriction

- For a single I/O module, do not execute multiple dedicated instructions at the same time. If multiple dedicated instructions are executed at the same time, the I/O module may be unable to receive the dedicated instructions, and the dedicated instructions may time out.
- Do not read or write data from/to any "Use prohibited" remote buffer memory areas. Otherwise, an accident may occur due to an incorrect output or malfunction.

List of remote buffer memory areas

This section describes the details of remote buffer memory addresses of the I/O module.

The remote buffer memory areas of the I/O module are assigned as shown below.

○: Access permitted, ×: Access not permitted

Remote buffer memory address		Area name	Target	Access method	
Decimal	Hexadecimal			CC IE Field configuration of the engineering tool	REMFR instruction, REMFRD instruction, REMTO instruction, REMTOD instruction ^{*1}
0 to 2559	0000H to 09FFH	Use prohibited		—	—
2560 to 2799	0A00H to 0AEFH	Error history area	Station-based error history data	○ ^{*2}	○
2800 to 4095	0AF0H to 0FFFH		Use prohibited	—	—
4096, 4097	1000H, 1001H	Module control data area	Station-based control data	×	○
4098 to 5375	1002H to 14FFH		Use prohibited	—	—
5376 to 65535	1500H to FFFFH	Use prohibited		—	—

*1 For the REMFR, REMFRD, REMTO, and REMTOD instructions, refer to the following manual.

 User's manual for the master/local module used

*2 For details on the access method, refer to the following.

 Page 205 Method for Checking Error Codes

Error history area

■Error history data

Remote buffer memory address		Name	Default value ^{*1}	Read/Write	
Decimal	Hexadecimal				
2560	0A00H	Error history data 1	Error code	0000H	R
2561	0A01H		Order of occurrence	0000H	R
2562	0A02H		[Error time] Western calendar year	0000H	R
2563	0A03H		[Error time] Month/Day	0000H	R
2564	0A04H		[Error time] Hour/Minute	0000H	R
2565	0A05H		[Error time] Second/00H (fixed)	0000H	R
2566	0A06H		Error code details 1	0000H	R
2567	0A07H		Error code details 2	0000H	R
2568	0A08H		Error code details 3	0000H	R
2569	0A09H		Error code details 4	0000H	R
2570	0A0AH		Error code details 5	0000H	R
2571	0A0BH		Error code details 6	0000H	R
2572	0A0CH		Error code details 7	0000H	R
2573	0A0DH		Error code details 8	0000H	R
2574	0A0EH		Error code details 9	0000H	R
2575	0A0FH		Error code details 10	0000H	R
2576 to 2591	0A10H to 0A1FH	Error history data 2	Same as Error history data 1		
2592 to 2607	0A20H to 0A2FH	Error history data 3	Same as Error history data 1		
2608 to 2623	0A30H to 0A3FH	Error history data 4	Same as Error history data 1		
2624 to 2639	0A40H to 0A4FH	Error history data 5	Same as Error history data 1		
2640 to 2655	0A50H to 0A5FH	Error history data 6	Same as Error history data 1		
2656 to 2671	0A60H to 0A6FH	Error history data 7	Same as Error history data 1		
2672 to 2687	0A70H to 0A7FH	Error history data 8	Same as Error history data 1		
2688 to 2703	0A80H to 0A8FH	Error history data 9	Same as Error history data 1		
2704 to 2719	0A90H to 0A9FH	Error history data 10	Same as Error history data 1		
2720 to 2735	0AA0H to 0AAFH	Error history data 11	Same as Error history data 1		
2736 to 2751	0AB0H to 0ABFH	Error history data 12	Same as Error history data 1		
2752 to 2767	0AC0H to 0ACFH	Error history data 13	Same as Error history data 1		
2768 to 2783	0AD0H to 0ADFH	Error history data 14	Same as Error history data 1		
2784 to 2799	0AE0H to 0AEFH	Error history data 15	Same as Error history data 1		
2800 to 4095	0AF0H to 0FFFH	Use prohibited	—	—	

*1 This is the value of factory default or the value of initialization by Error history clear command (address: 1000H).



Do not read or write data from/to any "Use prohibited" remote buffer memory areas. Otherwise, correct operation of the I/O module cannot be guaranteed.

Module control data area

■Module control data

Remote buffer memory address		Name	Default value ^{*1}	Read/Write
Decimal	Hexadecimal			
4096	1000H	Error history clear command	0000H	R/W
4097	1001H	Error history clear completed	0000H	R
4098 to 5375	1002H to 14FFH	Use prohibited	—	—

*1 This is the value for when the module power supply is turned off and on or at the remote reset.

Details of remote buffer memory

This section describes the details of remote buffer memory addresses of the I/O module.

Error history data

■Address

Name	Address
Error history data □	0A00H to 0AEFH

■Description

Up to 15 errors generated in the module are recorded.

The following tables show the stored content for Error history data 1 (address: 0A00H to 0A0FH).

Address	b15	b14	b13	b12	b11	b10	b9	b8	b7	b6	b5	b4	b3	b2	b1	b0
0A00H	Error code															
0A01H	Order of occurrence															
0A02H	First two digits of the year								Last two digits of the year							
0A03H	Month								Day							
0A04H	Hour								Minute							
0A05H	Second								00H (fixed)							
0A06H	Error code details 1															
0A07H	Error code details 2															
0A08H	Error code details 3															
0A09H	Error code details 4															
0A0AH	Error code details 5															
0A0BH	Error code details 6															
0A0CH	Error code details 7															
0A0DH	Error code details 8															
0A0EH	Error code details 9															
0A0FH	Error code details 10															

Item	Contents	Storage example ^{*1}
Error code	The error code for the error that occurred is stored.	—
Order of occurrence	The order of error occurrence is stored. (A value between 0 and 65535 is stored.) When the value exceeds 65535, counting starts from zero.	—
First two digits of the year/Last two digits of the year ^{*2}	The date and time of error occurrence is stored in BCD code.	2018H
Month/Day ^{*2}		0401H
Hour/Minute ^{*2}		1327H
Second ^{*2}		5400H
Error code details 1	The detailed information of some errors is stored. The data to be stored depends on the error.	—
Error code details 2		
Error code details 3	0 (fixed)	0
Error code details 4		
Error code details 5		
Error code details 6		
Error code details 7		
Error code details 8		
Error code details 9		
Error code details 10		

*1 Values for when an error occurred at 13:27:54, April 1, 2018

*2 The clock information of the error that occurred is based on the clock information acquired from the CPU module of the master station. When an error has occurred before the clock information is acquired from the CPU module, the error time is not recorded.

Error history data 2 to Error history data 15 (address: 0A10H to 0AEFH) are stored in the same format as that of Error history data 1 (address: 0A00H to 0A0FH).

For error codes, refer to the following.

 Page 211 Error Code List

■Storage order of the error history

The latest error is stored in Error history data 1 (address: 0A00H to 0A0FH).

Errors that occurred in the past are stored in Error history data 2 to Error history data 15 (address: 0A10H to 0AEFH) in reverse chronological order.

Error history clear command

■Address

Name	Address
Error history clear command	1000H

■Description

The error history stored in the module is cleared.

b15	b14	b13	b12	b11	b10	b9	b8	b7	b6	b5	b4	b3	b2	b1	b0
0 (fixed)															0: Not commanded 1: Commanded

■Operation of error history clear

When Error history clear command (address: 1000H) is set to Commanded (1), the error history is cleared.

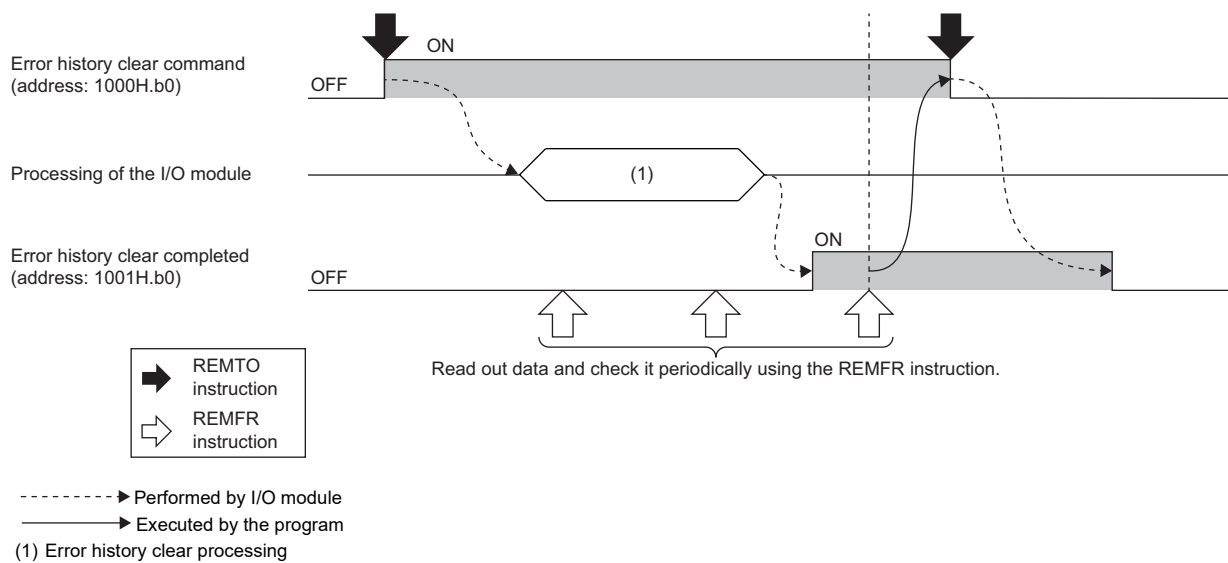

Point

- When the number of times that errors have been saved in the error history is the maximum number of times - 1 or when the maximum number of times has been reached, even if the Error history clear command (address: 1000H) is set to Commanded (1), the error history clear process is not performed. When the Error history clear command (address: 1000H) is set to Commanded (1), the Error history clear completed (address: 1001H) turns to Completed (1), but the error history remains uncleared.
- When the maximum number of times that errors can be saved in the error history is reached, an Error history save limit error (error code: 0220H) occurs.

■Default value

The default value is Not commanded (0).

Error history clear completed

■Address

Name	Address
Error history clear completed	1001H

■Description

This remote buffer memory area shows whether the error history stored in the module is cleared or not.

b15	b14	b13	b12	b11	b10	b9	b8	b7	b6	b5	b4	b3	b2	b1	b0
0 (fixed)															0: Not performed 1: Completed

■Operation of error history clear

When the error history clear is completed, Error history clear completed (address: 1001H) is turned to Completed (1).

For the timing of turning the bit to Not performed (0) → Completed (1) → Not performed (0), refer to the following.

☞ Page 240 Error history clear command

■Default value

The default value is Not performed (0).

Appendix 4 CC-Link IE Field Network Processing Time

The CC-Link IE Field Network processing time (transmission delay time) is structured as follows.

Sequence scan time + link scan time + master station switching time + processing time of slave station = transmission delay time

Among these, the processing time of slave station is expressed by either of the following.

- Input reflection processing time of slave station (input)
- Output reflection processing time of slave station (output)

The calculation formula for each is as follows.

Input reflection processing time of slave station (input)

The input reflection processing time of the slave station (input) = Input response time^{*1} + Internal processing time (100μs)

*1 If the input response time setting is "0ms", use 0.16ms for calculation.

Output reflection processing time of slave station (output)

The output reflection processing time of the slave station (output) = Output response time + Internal processing time (100μs)

For the output response time of the I/O module, refer to the following.

☞ Page 46 Output module, ☞ Page 79 I/O combined module

Appendix 5 EMC and Low Voltage Directives

Compliance to the EMC Directive, which is one of the EU Directives, has been a legal obligation for the products sold in European countries since 1996 as well as the Low Voltage Directive since 1997.

Manufacturers who recognize their products are compliant to the EMC and Low Voltage Directives are required to attach a "CE mark" on their products.

Sales representative in EU member states

Authorized representative in EU member states is shown below.

Name: MITSUBISHI ELECTRIC EUROPE B.V.

Address: Mitsubishi-Electric-Platz 1, 40882 Ratingen, Germany

Measures to comply with the EMC Directive

The EMC Directive specifies that "products placed on the market must be so constructed that they do not cause excessive electromagnetic interference (emissions) and are not unduly affected by electromagnetic interference (immunity)".

This section summarizes the precautions on compliance with the EMC Directive of the machinery constructed with the module.

These precautions are based on the requirements and the standards of the regulation, however, it does not guarantee that the entire machinery constructed according to the descriptions will comply with abovementioned directives.

The method and judgment for complying with the EMC Directive must be determined by the person who constructs the entire machinery.

EMC Directive related standards

■ Emission requirements

Specifications	Test item	Test details	Standard value
EN61131-2: 2007	CISPR16-2-3 Radiated emission*2	Radio waves from the product are measured.	<ul style="list-style-type: none">• 30M-230MHz QP: 40dBμV/m (10m in measurement range)*1• 230M-1000MHz QP: 47dBμV/m (10m in measurement range)
	CISPR16-2-1, CISPR16-1-2 Conducted emission*2	Noise from the product to the power line is measured.	<ul style="list-style-type: none">• 150k-500kHz QP: 79dB, Mean: 66dB*1• 500k-30MHz QP: 73dB, Mean: 60dB

*1 QP: Quasi-peak value, Mean: Average value

*2 The module is an open type device (a device designed to be housed in other equipment) and must be installed inside a conductive control panel. Except for the waterproof I/O module, the tests are conducted with the module installed in a control panel. (The I/O module (waterproof module) is tested outside the control panel.)

A

■Immunity requirements

Specifications	Test item	Test details	Standard value
EN61131-2: 2007	EN61000-4-2 Electrostatic discharge immunity* ¹	Static electricity is applied to the cabinet of the equipment.	<ul style="list-style-type: none"> • 8kV Air discharge • 4kV Contact discharge
	EN61000-4-3 Radiated, radio-frequency, electromagnetic field immunity* ¹	Electric fields are radiated to the product.	<ul style="list-style-type: none"> • 80% AM modulation@1kHz • 80M-1000MHz: 10V/m • 1.4G-2.0GHz: 3V/m • 2.0G-2.7GHz: 1V/m
	EN61000-4-4 Electrical fast transient/ burst immunity* ¹	Burst noise is applied to the power line and signal line.	<ul style="list-style-type: none"> • AC/DC main power, I/O power, AC I/O (unshielded): 2kV • DC I/O, analog, communication: 1kV
	EN61000-4-5 Surge immunity* ¹	A lightning surge is applied to the power line and signal line.	<ul style="list-style-type: none"> • AC power line, AC I/O power, AC I/O (unshielded): 2kV CM, 1kV DM • DC power line, DC I/O power: 0.5kV CM, DM • DC I/O, AC I/O (shielded), analog*², communication: 1kV CM
	EN61000-4-6 Conducted RF immunity* ¹	High frequency noise is applied to the power line and signal line.	0.15M-80MHz, 80% AM modulation @1kHz, 10Vrms
	EN61000-4-8 Power-frequency magnetic field immunity* ¹	The product is installed in an inductive magnetic field.	50Hz/60Hz, 30A/m
	EN61000-4-11 Voltage dips and interruption immunity* ¹	A momentary power failure is caused to the power supply voltage.	<ul style="list-style-type: none"> • Apply at 0%, 0.5 cycles and zero-cross point • 0%, 250/300 cycles (50/60Hz) • 40%, 10/12 cycles (50/60Hz) • 70%, 25/30 cycles (50/60Hz)

*1 The module is an open type device (a device designed to be housed in other equipment) and must be installed inside a conductive control panel. Except for the waterproof I/O module, the tests are conducted with the module installed in a control panel. (The I/O module (waterproof module) is tested outside the control panel.)

*2 The accuracy of an analog-digital converter module may temporarily vary within $\pm 10\%$.

Installation in a control panel

The module is open type devices and must be installed inside a control panel.

This ensures safety as well as effective shielding of programmable controller-generated electromagnetic noise.

■Control panel

- Use a conductive control panel.
- When securing the top or bottom plate using bolts, cover the grounding part on the control panel so that the part will not be painted.
- To ensure electrical contact between the inner plate and control panel, take measures such as covering the bolts so that conductivity can be ensured in the largest possible area.
- Ground the control panel with a thick ground cable so that low impedance can be ensured even at high frequencies.
- Holes in the control panel must be 10cm diameter or less. If the holes are larger than 10cm in diameter, radio waves may leak. In addition, because radio waves leak through a clearance between the control panel and its door, reduce the clearance as much as possible. The leakage of radio waves can be suppressed by the direct application of an EMI gasket on the paint surface.

Our tests have been carried out on a control panel having the damping characteristics of 37dB (max.) and 30dB (mean) (measured by 3m method, 30 to 300MHz).

■Wiring of power cables and ground cables

Near the power supply part, provide a ground point to the control panel. Ground the FG terminal with the thickest and shortest possible ground cable (30cm or shorter).

Cables

Use shielded cables for the cables which are connected to the module and run out from the control panel. If a shielded cable is not used or not grounded correctly, the noise immunity will not meet the specified value.

■Network cable

A shielded cable is used for the network cable. Strip a part of the jacket as shown below and ground the exposed shield in the largest possible area.

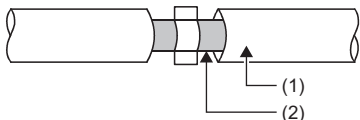

- (1) Network cable
- (2) Shield

■Grounding the cable clamp

Use shielded cables for external wiring and ground the shields of the external wiring cables to the control panel with the AD75CK-type cable clamp (Mitsubishi). (Ground the shield section 20 to 30cm away from the module.)

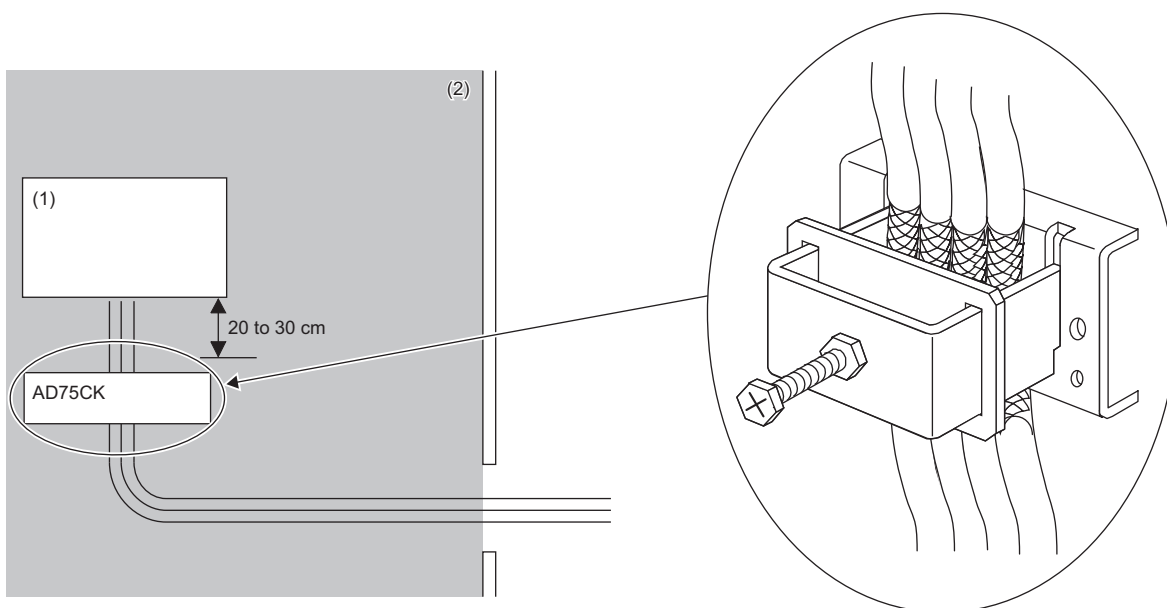

- (1) Module
- (2) Inside the control panel

For detail on AD75CK, refer to the following.

 AD75CK-type Cable Clamping Instruction Manual

External power supply

- Use a CE-marked product for an external power supply and always ground the FG terminal. (External power supply used for the tests conducted by Mitsubishi: TDK-Lambda DRJ100-24-1)
- Use a power cable of 10m or shorter when connecting it to the module power supply terminal.
- Use a power cable of 30m or shorter when connecting it to the external power supply for output part.
- Use a power cable of 3m or shorter when connecting it to the noise filter from the external power supply for output part.

A

40-pin connector

When wiring the 40-pin connector, take the following measures to reduce noise.

■Wiring example (when shielded cables are used)

The following figure shows an example of noise-reducing measures for wiring (when A6CON1 is used).

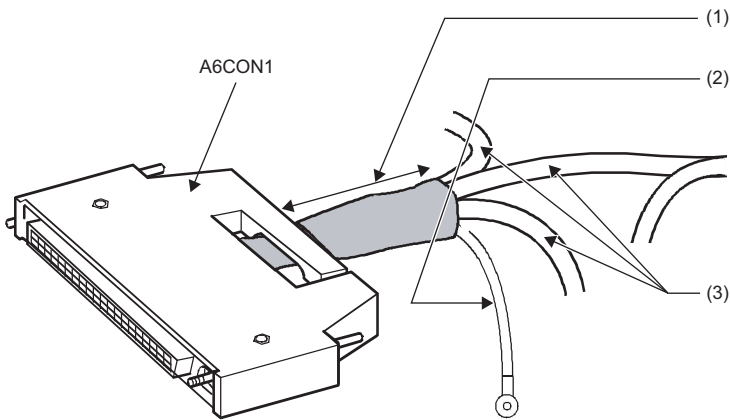

- (1) Keep the distance between the connector and shielded cables as short as possible.
- (2) Use an FG wire of 2mm² or thicker and as short as possible to ground it to the control panel. (Ground the FG wire on the module side (at the closest possible point to the module.))
- (3) Use shielded cables.

■Processing example of shielded cables

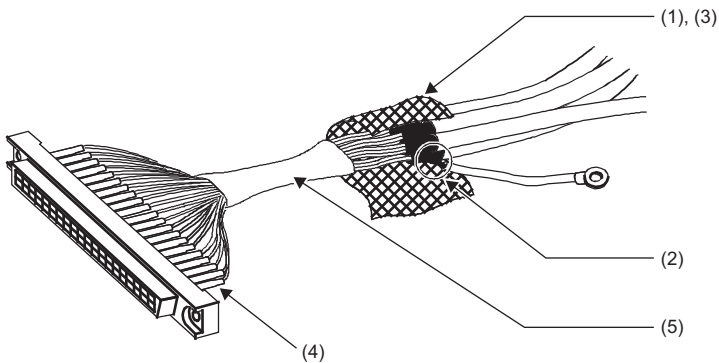

- (1) Strip the jacket of each shielded cable.
- (2) Choose one shielded cable, and solder its shield to the FG wire.
- (3) Bind shields of shielded cables together with a conductive tape.
- (4) Cover connector pins with heat-shrinkable insulation tubes to protect signal wires. If signal wires are uncovered, they may be affected by static electricity, resulting in malfunction of the module.
- (5) Cover the shields with an insulating tape.

Others

■ Ferrite core

A ferrite core has the effect of reducing radiated noise in the 30MHz to 100MHz band.

It is recommended to attach ferrite cores if shielded cables coming out of the control panel do not provide sufficient shielding effects.

However, for an input module, attach a ferrite core to the cable of the power supply of the connection target device.

Note that the ferrite cores must be attached at the position closest to the cable hole inside the control panel. If attached at an improper position, the ferrite core will not produce any effect.

For Ethernet cables as well as terminals that are connected to the module power supply of the I/O module and the external power supply, attach a ferrite core 4cm away from the I/O module.

The ferrite core has the effect of reducing externally conducted noise as well.

For an input module and an I/O combined module, attach a ferrite core to the cable of the power supply of the connection target device.

(Ferrite core used for the tests conducted by Mitsubishi: TOKIN Corporation ESD-SR-250, TDK Corporation ZCAT3035-1330)

Ex.

Ferrite core attachment example

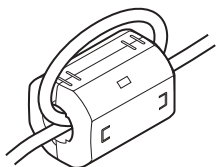

When using the I/O module (waterproof module) with the shielded cables not grounded on the module side, attach a ferrite core to signal wires to prevent the noise induced to the cables from affecting a load connected to the module.

(Ferrite core used for the tests conducted by Mitsubishi: KITAGAWA INDUSTRIES CO.,LTD. MRFC-13)

■ Noise filter (power supply line filter)

A noise filter is a component which has an effect on conducted noise. Attaching the filter can suppress more noise. (The noise filter has the effect of reducing conducted noise of 10MHz or less.)

Connect a noise filter to the external power supply of the I/O module. Use a noise filter with the damping characteristics equivalent to those of RSEN-2006 (manufactured by TDK-Lambda Corporation). Note that a noise filter is not required if the module is used in Zone A defined in EN61131-2.

The precautions for attaching a noise filter are described below.

- Do not bundle the cables on the input side and output side of the noise filter. If bundled, the output side noise will be induced into the input side cables from which the noise was filtered.

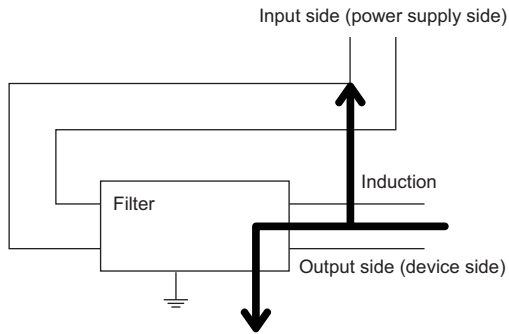

- Problem example

Noise is induced when the input and output cables are bundled.

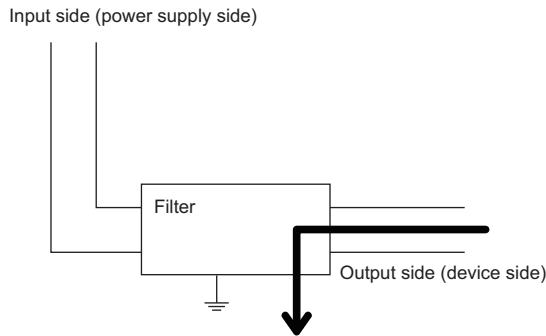

- Example of improvement

Install the input and output cables separately.

- Ground the noise filter grounding terminal to the control panel with the shortest cable possible (approx. 10cm).

Requirements to compliance with the Low Voltage Directive

The module operates at the rated voltage of 24VDC.

The Low Voltage Directive is not applied to the modules that operate at the rated voltage of less than 50VAC and 75VDC.

Appendix 6 How to Check Production Information and Firmware Version

Check the production information and the firmware version of an I/O module with the following.

- Rating plate
- CC-Link IE TSN/CC-Link IE Field Diagnostics

Point

To check the firmware version of an I/O module after performing a firmware update on it, do it in CC-Link IE TSN communication mode.

📖 CC-Link IE TSN Remote I/O Module User's Manual (CC-Link IE TSN Communication Mode)

Checking on the rating plate

■I/O module (except for waterproof module)

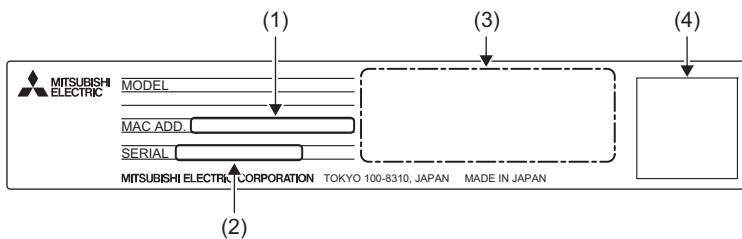

- (1) MAC address
- (2) Production information
- (3) Relevant standard symbol
- (4) QR code

■I/O module (waterproof module)

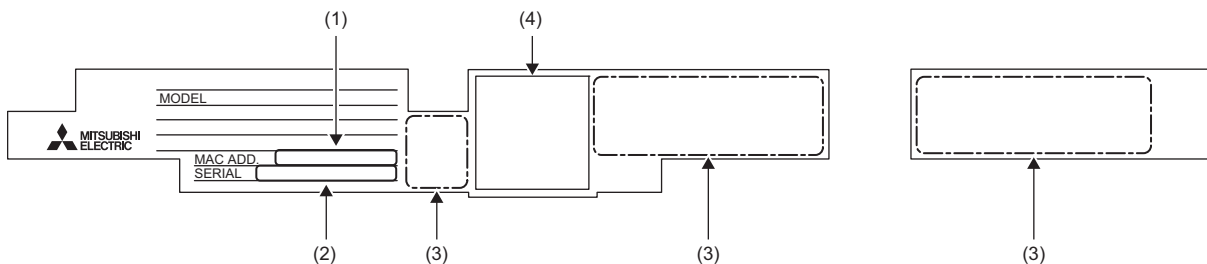

- (1) MAC address
- (2) Production information
- (3) Relevant standard symbol
- (4) QR code

Checking by using CC-Link IE TSN/CC-Link IE Field diagnostics

Operating procedure

1. Connect the engineering tool to the CPU module.
2. Start CC-Link IE TSN/CC-Link IE Field diagnostics from the menu.
🔗 [Diagnostics] ⇒ [CC-Link IE TSN/CC-Link IE Field Diagnostics]
3. Right-click the slave station whose production information you want to display, and select "Production Information".
4. The production information appears. (The first two digits show the firmware version.)

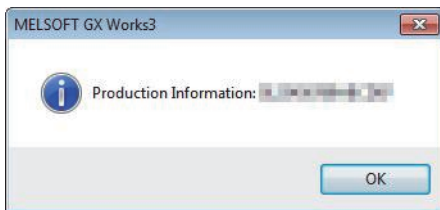

Appendix 7 External Dimensions

Spring clamp terminal block type

■16-point module

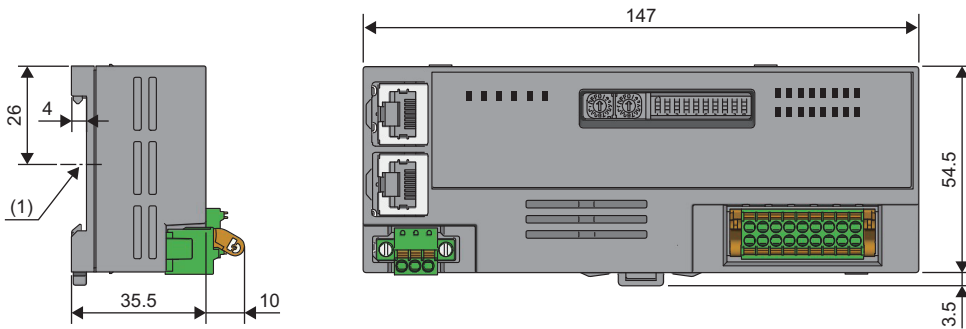

(1) Center of DIN rail

(Unit: mm)

■32-point module

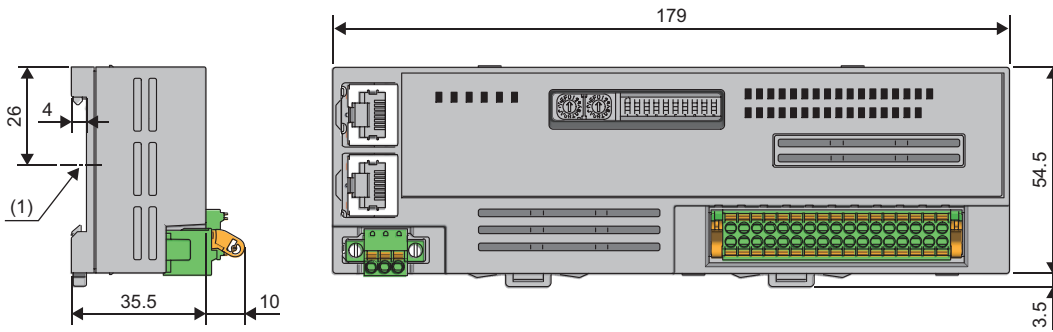

(1) Center of DIN rail

(Unit: mm)

Screw terminal block type

■16-point module

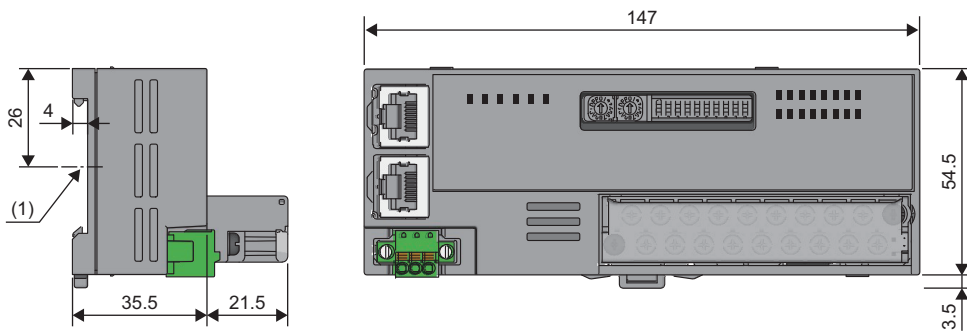

(1) Center of DIN rail

(Unit: mm)

■32-point module

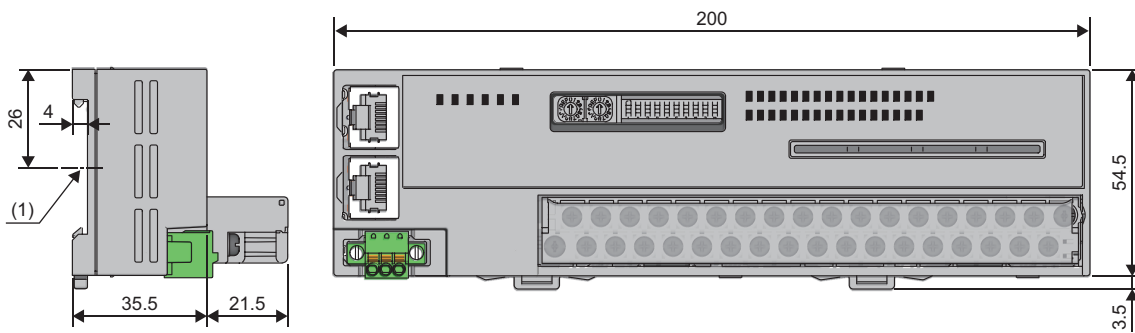

(1) Center of DIN rail

(Unit: mm)

40-pin connector type

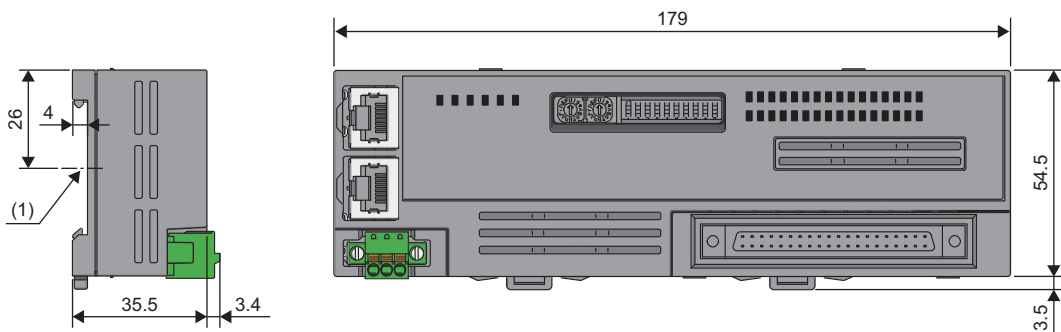

(1) Center of DIN rail

(Unit: mm)

Sensor connector (e-CON) type

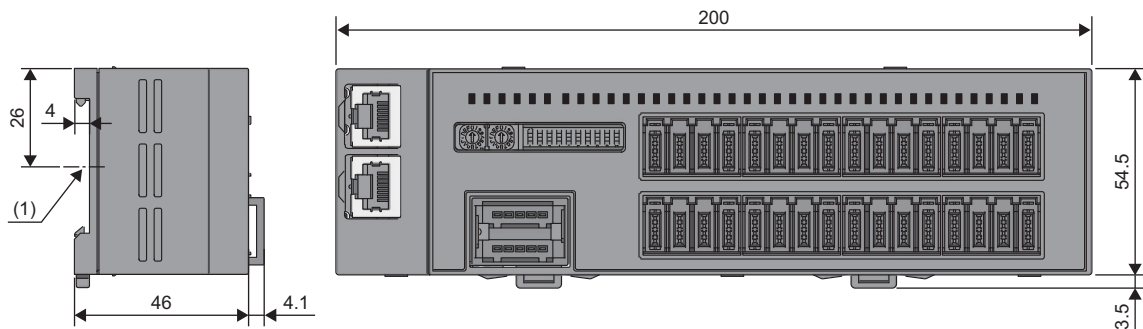

(1) Center of DIN rail
(Unit: mm)

Waterproof/dustproof connector type

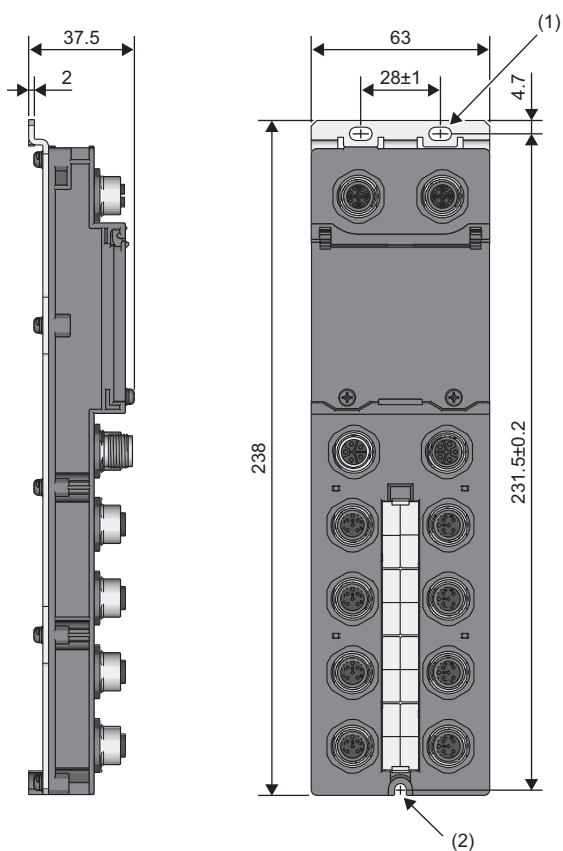

(1) 2-4.5 × 8 slotted hole (M4 mounting screw)
(2) M4 mounting screw
(Unit: mm)

MEMO

A

INDEX

A

- Applicable master station 108
- Applicable profile 109

C

- CC-Link IE Field Network Synchronous Communication Function 154
- CC-Link IE Field Network synchronous communication setting status (RWr2.b4, RWr2.b5) 228
- Compatible software version 108
- Connector for I/O 18
- Connector for module power supply and FG 18

D

- DATA LINK LED 17
- DIN rail hook 18

E

- ERR. LED 17
- Error clear request flag (RWw0.b10) 232
- Error code 227
- Error flag (RWr0.b10) 226
- Error history clear command 240
- Error history clear completed 241
- Error history data 238
- Ethernet cable 109
- External input signal 219
- External output signal 219
- External power supply monitor request (RWw2.b9) 233
- External power supply monitor status (RWr2.b9) 229

F

- Fast Link-Up Function 163
- Fast link-up setting status (PORT1) (RWr2.b6) 228
- Fast link-up setting status (PORT2) (RWr2.b7) 229
- Function selection setting area 233
- Function selection status area 228
- Function setting switch 17
- Function setting switch setting 117

H

- Hub 109

I

- I/O PW LED 17
- I/O terminal block 18
- Input response setting status (RWr2.b0 to RWr2.b2) 228
- Installation direction 121
- Installation environment 119
- Installation position 120

- IP address/station number setting switch 17

M

- Measures to comply with the EMC Directive 243
- Module operation area 232
- Module status area 226
- Mounting the I/O modules (except for waterproof module) on a DIN rail 122

O

- Output HOLD/CLEAR setting status (RWr2.b3) 228
- Output Y current value 229
- Output Y OFF information 231
- Output Y OFF information clear request 234
- Output Y ON information 230
- Output Y ON information clear request 234
- Overheat protection function 168
- Overload protection function 168

P

- P1 18
- P1 LINK LED 17
- P2 18
- P2 LINK LED 17
- PW LED 17

R

- Requirements to compliance with the Low Voltage Directive 249
- RUN LED 17

S

- Setting the IP address/station number setting switches 115

T

- Terminal block for module power supply and FG 18

MEMO

REVISIONS

*The manual number is given on the bottom left of the back cover.

Revision date	*Manual number	Revision
November 2019	SH(NA)-082240ENG-A	First edition
May 2020	SH(NA)-082240ENG-B	<p>■Added models NZ2GNCF1-32D, NZ2GNCE3-32D, NZ2GNCF1-32T, NZ2GNCE3-32DT</p> <p>■Added or modified parts SAFETY PRECAUTIONS, INTRODUCTION, RELEVANT MANUALS, Section 1.1, Chapter 2, Section 3.2, 3.3, 5.1, 6.2, 6.3, 6.6, 6.8, 8.2, 8.3, 8.4, 9.1, Chapter 10, Section 11.1, 11.2, 11.4, 11.6, 11.7, Appendix 1, 2, 5, 6, 7</p>
July 2020	SH(NA)-082240ENG-C	<p>■Added or modified parts SAFETY PRECAUTIONS, CONDITIONS OF USE FOR THE PRODUCT</p>
April 2021	SH(NA)-082240ENG-D	<p>■Added models NZ2GN2S1-16D, NZ2GN2B1-16D, NZ2GN2S1-16T, NZ2GN2B1-16T, NZ2GN2S1-16TE, NZ2GN2B1-16TE, NZ2GN12A4-16D, NZ2GN12A4-16DE, NZ2GN12A2-16T, NZ2GN12A2-16TE, NZ2GN12A42-16DT, NZ2GN12A42-16DTE</p> <p>■Added or modified parts SAFETY PRECAUTIONS, INTRODUCTION, RELEVANT MANUALS, TERMS, GENERIC TERMS AND ABBREVIATIONS, Section 1.1, 2.1, 2.2, 3.1, 3.2, 4.1, 4.2, 5.1, 6.3, Chapter 7, Section 8.1, 9.1, 9.3, 9.4, Chapter 11, Section 12.4, Appendix 1, 2, 4, 5, 6, 7</p>

Japanese manual number: SH-082239-D

This manual confers no industrial property rights or any rights of any other kind, nor does it confer any patent licenses. Mitsubishi Electric Corporation cannot be held responsible for any problems involving industrial property rights which may occur as a result of using the contents noted in this manual.

© 2019 MITSUBISHI ELECTRIC CORPORATION

WARRANTY

Please confirm the following product warranty details before using this product.

1. Gratis Warranty Term and Gratis Warranty Range

If any faults or defects (hereinafter "Failure") found to be the responsibility of Mitsubishi occurs during use of the product within the gratis warranty term, the product shall be repaired at no cost via the sales representative or Mitsubishi Service Company.

However, if repairs are required onsite at domestic or overseas location, expenses to send an engineer will be solely at the customer's discretion. Mitsubishi shall not be held responsible for any re-commissioning, maintenance, or testing on-site that involves replacement of the failed module.

[Gratis Warranty Term]

The gratis warranty term of the product shall be for one year after the date of purchase or delivery to a designated place. Note that after manufacture and shipment from Mitsubishi, the maximum distribution period shall be six (6) months, and the longest gratis warranty term after manufacturing shall be eighteen (18) months. The gratis warranty term of repair parts shall not exceed the gratis warranty term before repairs.

[Gratis Warranty Range]

- (1) The range shall be limited to normal use within the usage state, usage methods and usage environment, etc., which follow the conditions and precautions, etc., given in the instruction manual, user's manual and caution labels on the product.
- (2) Even within the gratis warranty term, repairs shall be charged for in the following cases.
 1. Failure occurring from inappropriate storage or handling, carelessness or negligence by the user. Failure caused by the user's hardware or software design.
 2. Failure caused by unapproved modifications, etc., to the product by the user.
 3. When the Mitsubishi product is assembled into a user's device, Failure that could have been avoided if functions or structures, judged as necessary in the legal safety measures the user's device is subject to or as necessary by industry standards, had been provided.
 4. Failure that could have been avoided if consumable parts (battery, backlight, fuse, etc.) designated in the instruction manual had been correctly serviced or replaced.
 5. Failure caused by external irresistible forces such as fires or abnormal voltages, and Failure caused by force majeure such as earthquakes, lightning, wind and water damage.
 6. Failure caused by reasons unpredictable by scientific technology standards at time of shipment from Mitsubishi.
 7. Any other failure found not to be the responsibility of Mitsubishi or that admitted not to be so by the user.

2. Onerous repair term after discontinuation of production

- (1) Mitsubishi shall accept onerous product repairs for seven (7) years after production of the product is discontinued. Discontinuation of production shall be notified with Mitsubishi Technical Bulletins, etc.
- (2) Product supply (including repair parts) is not available after production is discontinued.

3. Overseas service

Overseas, repairs shall be accepted by Mitsubishi's local overseas FA Center. Note that the repair conditions at each FA Center may differ.

4. Exclusion of loss in opportunity and secondary loss from warranty liability

Regardless of the gratis warranty term, Mitsubishi shall not be liable for compensation to:

- (1) Damages caused by any cause found not to be the responsibility of Mitsubishi.
- (2) Loss in opportunity, lost profits incurred to the user by Failures of Mitsubishi products.
- (3) Special damages and secondary damages whether foreseeable or not, compensation for accidents, and compensation for damages to products other than Mitsubishi products.
- (4) Replacement by the user, maintenance of on-site equipment, start-up test run and other tasks.

5. Changes in product specifications

The specifications given in the catalogs, manuals or technical documents are subject to change without prior notice.

TRADEMARKS

QR Code is either a registered trademark or a trademark of DENSO WAVE INCORPORATED in the United States, Japan, and/or other countries.

The company names, system names and product names mentioned in this manual are either registered trademarks or trademarks of their respective companies.

In some cases, trademark symbols such as [™] or [®] are not specified in this manual.

SH(NA)-082240ENG-D(2104)MEE

MODEL: CCIETSNIEF-IO-U-E

MODEL CODE: 13JX2F

mitsubishi electric corporation

HEAD OFFICE : TOKYO BUILDING, 2-7-3 MARUNOUCHI, CHIYODA-KU, TOKYO 100-8310, JAPAN
NAGOYA WORKS : 1-14, YADA-MINAMI 5-CHOME, HIGASHI-KU, NAGOYA, JAPAN

When exported from Japan, this manual does not require application to the
Ministry of Economy, Trade and Industry for service transaction permission.

Specifications subject to change without notice.