Transition from MELSERVO-J3/J3W Series to J4 Series Handbook

Existing manufacturing assets are completely utilizable.
MELSERVO-J3/J3W to MELSERVO-J4



● SAFETY INSTRUCTIONS ●

Please read the instructions carefully before using the equipment.

To ensure correct usage of the equipment, make sure to read through this Replacement Manual, the instruction manual, the Installation Guide, and the Appended Documents carefully before attempting to install, operate, maintain, or inspect the equipment. Do not use the equipment until you have a full knowledge of the equipment, safety information and instructions.

In this Replacement Manual, the safety instruction levels are classified under "WARNING" and "CAUTION".



WARNING

Indicates that incorrect handling may cause hazardous conditions, resulting in death or severe injury.



CAUTION

Indicates that incorrect handling may cause hazardous conditions, resulting in medium or slight injury to personnel or may cause physical damage.

Note that the  CAUTION level may lead to a serious consequence according to conditions.

Please follow the instructions of both levels because they are important to personnel safety.

What must not be done and what must be done are indicated by the following diagrammatic symbols.



Indicates prohibition (what must not be done). For example, "No Fire" is indicated by .



Indicates obligation (what must be done). For example, grounding is indicated by .

In this Replacement Manual, instructions of a lower level than the above, such as those that do not cause physical damage or instructions for other functions, are classified under "POINT".

After reading this instruction manual, keep it accessible to the operator.

1. To prevent electric shock, note the following



WARNING

- Before wiring or inspection, turn off the power and wait for 15 minutes or more (when 30 kW or more is used, 20 minutes or more) until the charge lamp turns off. Then, confirm that the voltage between P+ and N- is (when 30 kW or more is used, L+ and L-) safe with a voltage tester and others. Otherwise, an electric shock may occur. In addition, when confirming whether the charge lamp is off or not, always confirm it from the front of the servo amplifier.
- Ground the servo amplifier and servo motor securely.
- Any person who is involved in wiring and inspection should be fully competent to do the work.
- Do not attempt to wire the servo amplifier and servo motor until they have been installed. Doing so may cause an electric shock.
- Do not operate switches with wet hands. Otherwise, it may cause an electric shock.
- The cables should not be damaged, stressed, loaded, or pinched. Otherwise, it may cause an electric shock.
- During power-on or operation, do not open the front cover of the servo amplifier. Otherwise, it may cause an electric shock.
- Do not operate the servo amplifier with the front cover removed. High-voltage terminals and charging area are exposed and you may get an electric shock.
- Except for wiring and periodic inspection, do not remove the front cover of the servo amplifier even if the power is off. The servo amplifier is charged and you may get an electric shock.
- To prevent electric shock, always connect the protective earth (PE) terminal (⊕ marked) of the servo amplifier to the protective earth (PE) of the cabinet.
- To avoid an electric shock, insulate the connections of the power supply terminals.

2. To prevent fire, note the following



CAUTION

- Install the servo amplifier, servo motor, and regenerative resistor on incombustible material. Installing them directly or close to combustibles will lead to a fire.
- Be sure to connect a magnetic contactor between the power supply and the main circuit power supply (L1/L2/L3) of the servo amplifier, in order to configure a circuit that shuts off the power supply by the magnetic contactor. If the magnetic contactor is not connected, a continuous flow of a large current may cause smoke or a fire when the servo amplifier malfunctions.
- When using the regenerative resistor, switch power off with the alarm signal. Not doing so may cause smoke and fire when a regenerative transistor malfunctions or the like may overheat the regenerative resistor.
- Provide adequate protection to prevent screws and other conductive matter, oil and other combustible matter from entering the servo amplifier and servo motor.
- Be sure to connect a magnetic contactor for each servo amplifier between the power supply and the main circuit power supply (L1/L2/L3) of the servo amplifier, in order to configure a circuit that shuts off the power supply by the magnetic contactor. If a molded-case circuit breaker or fuse is not connected, a continuous flow of a large current may cause smoke or a fire when the servo amplifier malfunctions.

3. Injury prevention

 CAUTION
<ul style="list-style-type: none"> ● Only the voltage specified in the instruction manual should be applied to each terminal. Otherwise, a burst, damage, etc. may occur. ● The cables must be connected to the correct terminals. Otherwise, a burst, damage, etc. may occur. ● Ensure that the polarity (+/-) is correct. Otherwise, a burst, damage, etc. may occur. ● The servo amplifier heat sink, regenerative resistor, servo motor, etc. may be hot while power is on or for some time after power-off. Take safety measures, e.g. provide covers, to avoid accidentally touching the parts (cables, etc.) by hand. ● During operation, never touch the rotor of the servo motor. Otherwise, it may cause injury.

4. Additional instructions

The following instructions should also be fully noted. Incorrect handling may cause a malfunction, injury, electric shock, fire, etc.

(1) Transportation/installation

 CAUTION					
<ul style="list-style-type: none"> ● Transport the products correctly according to their mass. ● Stacking in excess of the specified number of product packages is not allowed. ● Do not hold the front cover, cable and connector when transporting the servo amplifier. Otherwise, it may drop. ● Install the servo amplifier and the servo motor in a load-bearing place in accordance with the instruction manual. ● Do not get on or put heavy load on the equipment. ● The equipment must be installed in the specified direction. ● Secure the prescribed distance between the servo amplifier and the inner surface of the cabinet or other devices. ● Do not install or operate the servo amplifier and servo motor which have been damaged or have any parts missing. ● Do not block the intake and exhaust areas of the servo amplifier. Otherwise, it may cause a malfunction. ● Do not drop or strike the servo amplifier and servo motor. Isolate them from all impact loads. ● Do not drop or apply heavy impact on the servo amplifiers and the servo motors. Otherwise, injury, malfunction, etc. may occur. ● Do not strike the connector. Otherwise, a connection failure, malfunction, etc. may occur. ● When you keep or use the equipment, please fulfill the following environment. 					
Item	Environment				
Ambient temperature	<table border="1" style="width: 100%; border-collapse: collapse;"> <tr> <td style="width: 15%; padding: 2px;">Operation</td> <td style="padding: 2px;">0 °C to 55 °C (non-freezing)</td> </tr> <tr> <td style="padding: 2px;">Storage</td> <td style="padding: 2px;">-20 °C to 65 °C (non-freezing)</td> </tr> </table>	Operation	0 °C to 55 °C (non-freezing)	Storage	-20 °C to 65 °C (non-freezing)
Operation	0 °C to 55 °C (non-freezing)				
Storage	-20 °C to 65 °C (non-freezing)				
Ambient humidity	<table border="1" style="width: 100%; border-collapse: collapse;"> <tr> <td style="width: 15%; padding: 2px;">Operation</td> <td rowspan="2" style="padding: 2px;">5 %RH to 90 %RH (non-condensing)</td> </tr> <tr> <td style="padding: 2px;">Storage</td> </tr> </table>	Operation	5 %RH to 90 %RH (non-condensing)	Storage	
Operation	5 %RH to 90 %RH (non-condensing)				
Storage					
Ambience	Indoors (no direct sunlight) and free from corrosive gas, flammable gas, oil mist, dust, and dirt				
Altitude	The altitude varies depending on the model. (Refer to each servo amplifier instruction manual.)				
Vibration resistance	5.9 m/s ² or less at 10 to 55 Hz (directions of X, Y, Z axes)				
<ul style="list-style-type: none"> ● Contact your local sales if the product has been stored for an extended period of time. ● When handling the servo amplifier, be careful about the edged parts such as corners of the servo amplifier. ● The servo amplifier must be installed in a metal cabinet. 					

⚠ CAUTION

- When fumigants that contain halogen materials, such as fluorine, chlorine, bromine, and iodine, are used for disinfecting and protecting wooden packaging from insects, they cause a malfunction when entering our products. Please take necessary precautions to ensure that remaining materials from fumigant do not enter our products, or treat packaging with methods other than fumigation, such as heat treatment. Additionally, disinfect and protect wood from insects before packing the products.
- To prevent a fire or injury from occurring in case of an earthquake or other natural disasters, securely install, mount, and wire the servo motor in accordance with servo amplifier instruction manual

(2) Wiring

⚠ CAUTION

- Wire the equipment correctly and securely. Otherwise, the servo motor may operate unexpectedly.
- Make sure to connect the cables and connectors by using the fixing screws and the locking mechanism. Otherwise, the cables and connectors may be disconnected during operation.
- Do not install a power capacitor, surge killer, or radio noise filter (optional FR-BIF(-H)) on the output side of the servo amplifier.
- Because installation of these items may cause the servo motor to malfunction, connect the wires to the correct phase terminals (U/V/W) of the servo amplifier and servo motor power supply.
- Directly connect the servo amplifier power output (U/V/W) to the servo motor power input (U/V/W). Do not let a magnetic contactor, etc. intervene. Otherwise, it may cause a malfunction.

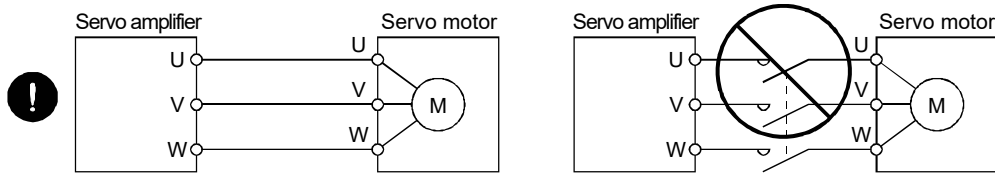

- The connection diagrams in this instruction manual are shown for sink interfaces, unless stated otherwise.
- The surge absorbing diode installed to the DC relay for control output should be fitted in the specified direction. Otherwise, the emergency stop and other protective circuits may not operate.

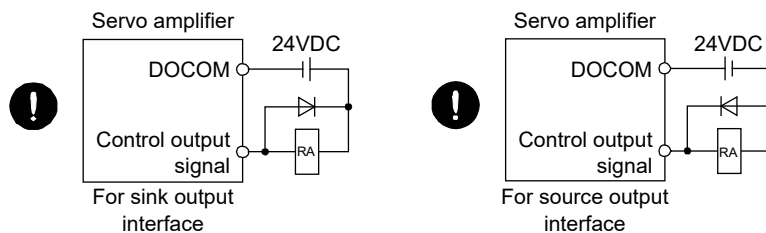

- When the cable is not tightened enough to the terminal block, the cable or terminal block may generate heat because of the poor contact. Be sure to tighten the cable with specified torque.
- To avoid a malfunction, do not connect the U, V, W, and CN2 phase terminals of the servo amplifier to the servo motor of an incorrect axis.
- Configure a circuit to turn off EM2 or EM1 when the main circuit power is turned off to prevent an unexpected restart of the servo amplifier.
- To prevent malfunction, avoid bundling power lines (input/output) and signal cables together or running them in parallel to each other. Separate the power lines from the signal cables.

(3) Trial run/adjustment

CAUTION

- When executing a test run, follow the notice and procedures in this instruction manual. Otherwise, it may cause a malfunction, damage to the machine, or personal injury.
- Before operation, check the parameter settings. Improper settings may cause some machines to operate unexpectedly.
- Never perform extreme adjustment or changes to the parameters; otherwise, the operation may become unstable.
- Keep away from moving parts in a servo-on state.

(4) Usage

CAUTION

- Provide an external emergency stop circuit to ensure that operation can be stopped and power switched off immediately.
- For equipment in which the moving part of the machine may collide against the load side, install a limit switch or stopper to the end of the moving part. The machine may be damaged due to a collision.
- Do not disassemble, repair, or modify the product.
Disassembled, repaired, and/or modified products are not covered under warranty.
- Before resetting an alarm, make sure that the run signal of the servo amplifier is off in order to prevent a sudden restart. Otherwise, it may cause an accident.
- The effect of electromagnetic interference must be reduced by using a noise filter or by other means.
Electromagnetic interference may be given to the electronic equipment used near the servo amplifier.
- Burning or disassembling a servo amplifier may generate toxic gases. Do not burn or break it.
- Use the servo amplifier with the specified servo motor.
- Correctly wire options and peripheral equipment, etc. in the correct combination. Otherwise, it may cause an electric shock, fire, or injury.
- The electromagnetic brake on the servo motor is designed to hold the motor shaft and should not be used for ordinary braking.
- For such reasons as incorrect wiring, service life, and mechanical structure (e.g. where a ball screw and the servo motor are coupled via a timing belt), the electromagnetic brake may not hold the motor shaft. To ensure safety, install a stopper on the machine side.
- If the dynamic brake is activated at power-off, alarm occurrence, etc., do not rotate the servo motor by an external force. Otherwise, it may cause a fire.

(5) Corrective actions

CAUTION

- If it is assumed that a power failure, machine stoppage, or product malfunction may result in a hazardous situation, use a servo motor with an electromagnetic brake or provide an external brake system for holding purpose to prevent such hazard.

⚠ CAUTION

- Configure an electromagnetic brake circuit so that it is activated also by an external emergency stop switch.

Contacts must be opened with the ALM (malfunction) off or the MBR (electromagnetic brake interlock) off.

Contacts must be opened with the EMG stop switch.

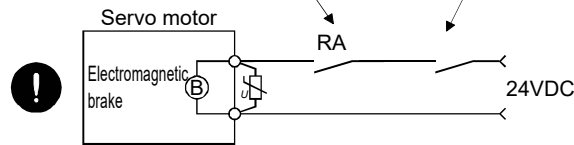

- When any alarm has occurred, eliminate its cause, ensure safety, and deactivate the alarm before restarting operation.
- If the molded-case circuit breaker or fuse is activated, be sure to remove the cause and secure safety before switching the power on. If necessary, replace the servo amplifier and recheck the wiring. Otherwise, it may cause smoke, fire, or an electric shock.
- Provide an adequate protection to prevent unexpected restart after an instantaneous power failure.
- To prevent an electric shock, injury, or fire from occurring after an earthquake or other natural disasters, ensure safety by checking conditions, such as the installation, mounting, wiring, and equipment before switching the power on.

(6) Maintenance, inspection and parts replacement

⚠ CAUTION

- Make sure that the emergency stop circuit operates properly such that an operation can be stopped immediately and a power is shut off by the emergency stop switch.
- It is recommended that the servo amplifier be replaced every 10 years when it is used in general environment.
- When using a servo amplifier whose power has not been turned on for a long time, contact your local sales office.

(7) General precautions

- To illustrate details, the equipment in the diagrams of this Replacement Manual may have been drawn without covers and safety guards. When the equipment is operated, the covers and safety guards must be installed as specified. Operation must be performed in accordance with instruction manual.

● Disposal of Waste ●

When disposing of this product, the following two laws are applicable, and it is necessary to consider each law. In addition, because the following laws are effective only in Japan, local laws have priority outside Japan (overseas). We ask that the local laws be displayed on the final products or that a notice be issued as necessary.

1. Requirements of the Act on the Promotion of Effective Utilization of Resources (Commonly known as: the Law for Promotion of Effective Utilization of Resources Promotion Law)

- (1) Please recycle this product whenever possible when it becomes unnecessary.
- (2) It is recommended that this product be divided as necessary and sold to appropriate purchasers, as recycled resources are usually divided into iron, electrical parts, and so on, which are then sold to scrap processors.

2. Requirements of the Act on Waste Disposal & Cleaning (Commonly known as: The Waste Disposal Treatment Cleaning Act)

- (1) It is recommended to decrease waste through the sale of recyclables or through any other means as shown in the preceding Paragraph 1.
- (2) In case the unnecessary products cannot be sold and require disposal, such item falls under Industrial waste in the above act.
- (3) It is required that industrial waste be properly dealt with, including manifest management, by commissioning the disposal to an industrial waste disposal contractor licensed under the act.
- (4) Please dispose of batteries (primary batteries) used in servo amplifiers according to local regulations.

Measures against servo amplifier harmonics

This servo amplifier applies to "Harmonics control guidelines for customers receiving high voltage or special high voltage power" (published by current Ministry of Economy, Trade and Industry). Consumers subject to this guideline must check if a harmonic suppression measure is necessary, and measures must be enforced when the limit level is exceeded.



EEP-ROM life

The number of write times to the EEP-ROM, which stores parameter settings, etc., is limited to 100,000. If the total number of the following operations exceeds 100,000, the servo amplifier may malfunction when the EEP-ROM reaches the end of its useful life.

- Write to the EEP-ROM due to parameter setting changes
- Write to the EEP-ROM due to device changes

STO function of the servo amplifier

See the applicable "Servo Amplifier Instruction Manual" when using the STO function of the servo amplifier.

Dealing with overseas standards

See the following relevant manuals concerning dealing with overseas standards.

«About the manual»

This Replacement Manual and the following Instruction Manuals are necessary when using this servo for the first time. Ensure to prepare them to use the servo safely.

Relevant manuals

Manual name	Manual number
MR-J4 Series Instructions and Cautions for Safe Use of AC Servos (Packed with the servo amplifier)	IB(NA)0300175
MR-J4 Servo Amplifier Instruction Manual (Troubleshooting)	SH(NA)030109
HG-MR/HG-KR/HG-SR/HG-JR/HG-RR/HG-UR/HG-AK Servo Motor Instruction Manual (Vol. 3) (Note 1)	SH(NA)030113
LM-H3/LM-U2/LM-F/LM-K2 Linear Servo Motor Instruction Manual (Note 2)	SH(NA)030110
TM-RFM/TM-RG2M/TM-RU2M Direct Drive Motor Instruction Manual (Note 3)	SH(NA)030112
Linear Encoder Instruction Manual (Note 2, 4)	SH(NA)030111
EMC Installation Guidelines	IB(NA)67310
MR-J4- <u>A</u> (-RJ)/MR-J4-03A6(-RJ) Servo Amplifier Instruction Manual	SH(NA)030107
MR-J4- <u>B</u> (-RJ) Servo Amplifier Instruction Manual	SH(NA)030106
MR-J4W2- <u>B</u> /MR-J4W3- <u>B</u> /MR-J4W2-0303B6 Servo Amplifier Instruction Manual	SH(NA)030105
MR-CV /MR-CR55K /MR-J4-DU- <u>B</u> (-RJ)/MR-J4-DU- <u>A</u> (-RJ) Instruction Manual	SH(NA)030153
MR-J4- <u>A</u> -RJ/MR-J4-03A6-RJ Servo Amplifier Instruction Manual (Positioning Mode)	SH(NA)030143
MR-J4- <u>GF</u> (-RJ) Servo Amplifier Instruction Manual (Motion Mode)	SH(NA)030218
MR-J4- <u>GF</u> (-RJ) Servo Amplifier Instruction Manual (I/O Mode)	SH(NA)030221

- Note
1. It is necessary for using a rotary servo motor.
 2. It is necessary for using a linear servo motor.
 3. It is necessary for using a direct drive motor.
 4. It is necessary for using a fully closed loop system.

«Cables used for wiring»

The wiring cables mentioned in this Replacement Manual are selected based on an ambient temperature of 40°C.

«U.S. customary units»

U.S. customary units are not shown in this manual. Convert the values if necessary according to the following table.

Quantity	SI (metric) unit	U.S. customary unit
Mass	1 [kg]	2.2046 [lb]
Length	1 [mm]	0.03937 [inch]
Torque	1 [N•m]	141.6 [oz•inch]
Moment of inertia	1 [(× 10 ⁻⁴ kg•m ²)]	5.4675 [oz•inch ²]
Load (thrust load/axial load)	1 [N]	0.2248 [lbf]
Temperature	N [°C] × 9/5 + 32	N [°F]

CONTENTS

Part 1: Summary of MR-J3/MR-J3W Replacement	1- 1 to 1-20
---	--------------

1. SUMMARY OF MR-J3/MR-J3W REPLACEMENT.....	1- 2
2. MAJOR REPLACEMENT TARGET MODEL.....	1- 2
2.1 Servo Amplifier Replacement Target Model.....	1- 2
2.2 Servo Motor Replacement Target Model.....	1- 2
3. FLOW OF REPLACEMENT	1- 3
3.1 Summary.....	1- 3
3.1.1 Flow of Review on Replacement	1- 3
3.1.2 Configuration diagram	1- 4
3.1.3 Changes from MR-J3 series to MR-J4 series.....	1- 5
3.1.4 Changes from MR-J3W series to MR-J4 series	1- 7
3.2 Review on replacement	1- 9
3.2.1 Checking the system prior to replacement	1- 9
3.2.2 Determination of base replacement model.....	1-10
3.2.3 Attachment compatibility check	1-18
3.2.4 Detailed review on replacement model	1-18
3.2.5 Peripheral equipment check	1-18
3.2.6 Startup procedure check.....	1-18
4. RELATED MATERIALS.....	1-18
4.1 Catalog.....	1-18
4.2 Instruction Manual	1-19
4.3 Migration Guide	1-19
4.4 Replacement Tool for Replacing MR-J3 with MR-J4	1-19
4.5 MITSUBISHI ELECTRIC FA Global Website	1-20

Part 2: Review on Replacement of MR-J3- <u>A</u> with MR-J4- <u>A</u>	2- 1 to 2-66
---	--------------

1. SUMMARY.....	2- 2
2. CASE STUDY ON REPLACEMENT OF MR-J3- <u>A</u>	2- 2
2.1 Review on Replacement Method.....	2- 2
2.2 Replacement Method.....	2- 2
3. DIFFERENCES BETWEEN MR-J3- <u>A</u> AND MR-J4- <u>A</u>	2- 4
3.1 Function Comparison Table.....	2- 4
3.2 Comparison of Standard Connection Diagrams.....	2- 7
3.3 List of Corresponding Connectors and Terminal Blocks	2- 9
3.4 Comparison of Peripheral Equipment.....	2-14
3.5 Comparison of Parameters.....	2-15
3.5.1 Setting requisite parameters upon replacement.....	2-15
3.5.2 Parameter comparison list.....	2-17
3.5.3 Comparison of parameter details.....	2-21
3.6 Important Points for Replacement.....	2-64

Part 3: Review on Replacement of MR-J3- <u>B</u> with MR-J4- <u>B</u>	3- 1 to 3-48
---	--------------

1. SUMMARY.....	3- 2
2. CASE STUDY ON REPLACEMENT OF MR-J3- <u>B</u>	3- 2
2.1 Review on Replacement Method.....	3- 2
2.2 Replacement Method.....	3- 3
3. DIFFERENCES BETWEEN MR-J3- <u>B</u> AND MR-J4- <u>B</u>	3- 6

3.1	Function Comparison Table.....	3- 6
3.2	Comparison of Networks	3- 9
3.3	Comparison of Standard Connection Diagrams.....	3- 9
3.4	List of Corresponding Connectors and Terminal Blocks	3-10
3.5	Comparison of Peripheral Equipment.....	3-13
3.6	Comparison of Parameters.....	3-13
3.6.1	Setting requisite parameters upon replacement.....	3-14
3.6.2	Parameter comparison list.....	3-15
3.6.3	Comparison of parameter details.....	3-18
4.	APPLICATION OF FUNCTIONS.....	3-47

Part 4: Replacement of MR-J3W-_B with MR-J4W2-_B	4- 1 to 4-52
---	---------------------

1.	SUMMARY.....	4- 2
2.	CASE STUDY ON REPLACEMENT OF MR-J3W-_B.....	4- 2
2.1	Review on Replacement Method.....	4- 2
2.2	Servo Amplifier Replacement Model	4- 2
2.3	Replacement Method.....	4- 3
3.	DIFFERENCES BETWEEN MR-J3W-_B AND MR-J4W2-_B	4- 6
3.1	Function Comparison Table.....	4- 6
3.2	Configuration including auxiliary equipment.....	4- 8
3.3	Comparison of Networks	4-12
3.4	Comparison of Standard Connection Diagrams.....	4-12
3.5	List of Corresponding Connectors and Terminal Blocks	4-14
3.5.1	200 V class	4-14
3.5.2	48 V DC/24 V DC class	4-17
3.6	Comparison of Peripheral Equipment.....	4-19
3.7	Comparison of Parameters.....	4-20
3.7.1	Setting requisite parameters upon replacement.....	4-21
3.7.2	Parameter comparison list.....	4-22
3.7.3	Comparison of parameter details.....	4-26
4.	APPLICATION OF FUNCTIONS.....	4-51

Part 5: Review on Replacement of MR-J3-DU_ with MR-J4-DU_	5- 1 to 5-78
--	---------------------

1.	SUMMARY.....	5- 2
2.	FUNCTIONS AND CONFIGURATION	5- 2
2.1	Differences between MR-J3-DU_ and MR-J4-DU_.....	5- 2
2.2	Combination of converter unit, drive unit, and servo motor.....	5- 3
2.3	Configuration including peripheral equipment.....	5- 5
3.	INSTALLATION	5- 7
3.1	Installation direction and clearances	5- 7
3.2	Magnetic contactor control connector (CNP1).....	5- 9
4.	SIGNALS AND WIRING	5-11
4.1	Comparison of standard connection diagrams.....	5-11
4.1.1	When magnetic contactor drive output is enabled (factory setting).....	5-11
4.1.2	When magnetic contactor control connector (CNP1) is made invalid	5-16
4.2	Power-on sequence.....	5-21
4.3	List of corresponding connectors and terminal blocks	5-29
5.	PARAMETER.....	5-37
5.1	Converter unit	5-37
5.1.1	Converter unit parameter comparison list.....	5-37

5.1.2 Converter unit comparison of parameter details.....	5-38
5.2 Drive unit.....	5-41
5.2.1 Drive unit comparison of parameter details	5-41
6. CHARACTERISTICS	5-43
6.1 Overload protection characteristics	5-43
6.2 Power supply capacity and generated loss	5-46
6.3 Inrush currents at power-on of main circuit/control circuit.....	5-48
7. OPTIONS AND PERIPHERAL EQUIPMENT.....	5-49
7.1 Comparison table of cable option combinations.....	5-49
7.1.1 MR-J3CDL05M (0.5 m) Protection coordination cable	5-50
7.2 Selection example of wires.....	5-51
7.2.1 MR-J3 series, power supply wire size	5-51
7.2.2 MR-J4 series, power supply wire size	5-53
7.3 Selection of Molded-case circuit breakers, fuses, magnetic contactors (example).....	5-55
7.3.1 MR-J3-DU_ Molded-case circuit breakers, fuses, magnetic contactors (recommended)..	5-55
7.3.2 MR-J4-DU_ Molded-case circuit breakers, fuses, magnetic contactors (recommended)..	5-55
7.4 FR-BU2-(H) brake unit.....	5-57
7.4.1 Selection	5-57
7.4.2 Brake unit parameter setting.....	5-58
7.4.3 Connection example	5-58
7.4.4 Dimensions	5-74
7.5 Regenerative option.....	5-76
7.5.1 Combination and regenerative power.....	5-76
7.6 External dynamic brake	5-77
7.6.1 MR-J3 series.....	5-77
7.6.2 MR-J4 series.....	5-78

Part 6: Review on Replacement of MR-J3-_T_(DIO command/ Serial communication operation) with MR-J4-_A_-RJ	6- 1 ~ 6-98
---	-------------

1. SUMMARY.....	6- 3
2. CASE STUDY ON REPLACEMENT OF MR-J3-_T_ (DIO command/Serial communication operation)	
.....	6- 3
2.1 Review on Replacement Method.....	6- 3
2.2 Replacement Method.....	6- 5
3. DIFFERENCES BETWEEN MR-J3-_T_(DIO command/Serial communication operation)	
AND MR-J4-_A_-RJ.....	6- 8
3.1 Function Comparison Table.....	6- 8
3.1.1 DIO command/Serial communication operation specifications	6-15
3.1.2 Function list.....	6-17
3.2 Configuration including auxiliary equipment.....	6-20
3.3 Comparison of Standard Connection Diagrams.....	6-24
3.4 List of Corresponding Connectors and Terminal Blocks	6-30
3.5 Comparison of Peripheral Equipment.....	6-37
3.5.1 MR-J3-_T_/ MR-J4-_A_-RJ	6-37
3.5.2 Extension I/O unit.....	6-37
3.6 Comparison of Parameters.....	6-38
3.6.1 Setting requisite parameters upon replacement.....	6-38
3.6.2 Parameter comparison list	6-41
3.6.3 Comparison of parameter details.....	6-44
3.7 Important Points for Replacement.....	6-86
4. COMMUNICATION FUNCTION.....	6-89

4.1 Command and data No. list	6-89
4.1.1 Reading command comparison between MR-J3-_T_ and MR-J4-_A_-RJ ([Pr. PT01]: "1__").....	6-88
4.1.2 Writing command comparison between MR-J3-_T_ and MR-J4-_A_-RJ ([Pr. PT01]: "1__").....	6-95

Part 7: Review on Replacement of MR-J3-_T_ (CC-Link communication operation) with MR-J4-_GF_	7- 1 ~ 7-82
--	-------------

1. SUMMARY.....	7- 3
2. MR-J3-_T_ (CC-Link COMMUNICATION OPERATION) REPLACEMENT CASE STUDY	7- 3
2.1 Examination of replacement method	7- 3
2.2 Replacement method.....	7- 4
3. DIFFERENCES BETWEEN THE MR-J3-_T_ (CC-Link COMMUNICATION OPERATION) AND MR-J4-_GF_	7- 7
3.1 Function comparison table.....	7- 7
3.1.1 CC-Link ⇒ CC-Link IE Field Network communication operation specifications list	7-13
3.1.2 Function list.....	7-15
3.1.3 Detailed comparison of functions.....	7-17
3.2 Configuration including peripheral equipment	7-21
3.3 List of Corresponding Connectors and Terminal Blocks	7-23
3.4 List of supported connectors and terminal blocks	7-24
3.5 Peripheral equipment compatibility comparison	7-28
3.5.1 MR-J3-_T_/MR-J4-_GF_	7-28
3.6 Parameter comparison	7-29
3.6.1 Parameters required to be set when replacing.....	7-30
3.6.2 Parameter comparison list	7-32
3.6.3 Parameter detail comparison.....	7-36
3.7 Replacement points and precautions	7-77

Part 8: Common Reference Material	8- 1 to 8-172
-----------------------------------	---------------

1. SPECIFICATION DIFFERENCES.....	8- 2
1.1 Detailed Specification/Function Differences	8- 2
1.2 Servo amplifier	8- 4
1.2.1 Main circuit terminal block	8- 4
1.2.2 Comparison of encoder signals (CN2).....	8- 9
1.2.3 Dynamic brake: coasting distance	8-10
1.2.4 Forced stop deceleration function selection	8-20
1.2.5 Servo setup software: Setup software (SETUP221E) => MR Configurator2	8-22
1.2.6 Servo amplifier initializing time	8-23
1.2.7 The pulse width of the encoder Z-Phase pulse	8-26
1.3 Overload protection characteristics	8-27
1.4 Comparison of Networks	8-35
1.4.1 Comparison of servo system network specifications.....	8-35
2. SERVO AMPLIFIER DIMENSIONS/ATTACHMENT DIFFERENCES	8-37
2.1 MR-J3 series => MR-J4 series Comparison Table of Servo Amplifier Dimensions/ Installation Differences	8-37
2.1.1 1-axis servo amplifier 200 V/100 V class (22 kW or less)	8-37
2.1.2 1-axis servo amplifier 400 V class (22 kW or less).....	8-44
2.1.3 MR-J3-D01/MR-D01	8-48
2.1.4 Drive unit and converter unit 200 V class (30 kW or more).....	8-49

2.1.5	Drive unit and converter unit 400 V class (30 kW or more)	8-51
2.1.6	Multi-axis servo amplifier	8-53
2.2	Parameter conversion	8-54
2.2.1	Operation procedure of parameter conversion	8-54
2.2.2	MR-J3-_A_/MR-J3-_T_ parameter diversion procedure	8-55
2.2.3	Parameter reading from the servo amplifier MR- J3-_A_/MR-J3-_T_	8-56
2.2.4	Converting the parameters of MR-J3-_A_/MR-J3-_T_ and writing them to the MR-J4-_A_ (-RJ) servo amplifier	8-58
2.2.5	Conversion rules (MR-J3-_A_ => MR-J4-_A_)	8-61
2.2.6	Parameters that need to be checked after parameter conversion	8-66
2.2.7	Conversion rules (MR-J3-_T_(DIO Command/ Serial communication operation) => MR-J4-_A_-RJ)	8-67
2.2.8	Parameters that need to be checked after parameter conversion	8-75
2.2.9	Conversion rules (MR-J3-_T_(CC-Link communication operation) ⇒ MR-J4-_GF_)	8-76
2.2.10	Parameters requiring check after parameter conversion	8-83
2.3	MR-J3-_B_ and MR-J3W-_B_ Parameter Diversion Procedure	8-85
2.3.1	Changing QD75MH to QD77MS/LD77MS	8-86
2.3.2	Changing Q17nHCPU/Q17nDCPU/Q170MCPUCPU to Q17nDSCPU/Q170MSCPU(-S1)	8-88
2.3.3	Conversion rules (MR-J3-_B_ and MR-J3W-_B_ => MR-J4-_B_ and MR-J4W2-_B_)	8-90
2.3.4	Parameters that need to be checked after parameter conversion	8-95
3.	COMMON POINTS TO NOTE	8-97
3.1	Method for checking the software version	8-97
3.1.1	Checking with MR Configurator2 (SW1DNC-MRC2-E)	8-97
4.	COMMUNICATION FUNCTION (MITSUBISHI GENERAL-PURPOSE AC SERVO PROTOCOL)	8-98
4.1	Structure	8-99
4.1.1	Configuration diagram	8-99
4.1.2	Precautions for using RS-422/RS-232C/USB communication function	8-101
4.2	Communication specifications	8-102
4.2.1	Outline of communication	8-102
4.2.2	Parameter setting	8-102
4.3	Protocol	8-103
4.3.1	Transmission data configuration	8-103
4.3.2	Character codes	8-104
4.3.3	Error codes	8-105
4.3.4	Checksum	8-105
4.3.5	Time-out processing	8-105
4.3.6	Retry processing	8-106
4.3.7	Initialization	8-106
4.3.8	Communication procedure example	8-107
4.4	Command and data No. list	8-108
4.4.1	Reading command	8-108
4.4.2	Writing commands	8-113
4.5	Detailed explanations of commands	8-115
4.5.1	Data processing	8-115
4.5.2	Status display mode	8-117
4.5.3	Parameter	8-118
4.5.4	External I/O signal status (DIO diagnosis)	8-122
4.5.5	Input device on/off	8-125
4.5.6	Disabling/enabling I/O devices (DIO)	8-126
4.5.7	Input devices on/off (test operation)	8-127
4.5.8	Test operation mode	8-128

4.5.9	Output signal pin on/off (output signal (DO) forced output).....	8-132
4.5.10	Alarm history.....	8-133
4.5.11	Current alarm.....	8-134
4.5.12	Other commands.....	8-135
5.	HF-_P/HA-_P/HC-_P MOTOR DRIVE.....	8-137
5.1	MR-J3 series servo motors which are available with MR-J4-_A_ and MR-J4-_B_.....	8-137
5.2	MR-J3 series servo motors which are available with MR-J4W_ -_B_.....	8-147
6.	APPLICATION OF FUNCTIONS.....	8-149
6.1	J3 compatibility mode.....	8-149
6.1.1	J3 Outline of J3 compatibility mode.....	8-149
6.1.2	Operation modes supported by J3 compatibility mode.....	8-149
6.1.3	J3 compatibility mode supported function list.....	8-150
6.1.4	Distinguishing J3 compatibility mode.....	8-153
6.1.5	How to switch J4 mode/J3 compatibility mode.....	8-154
6.1.6	How to use the J3 compatibility mode.....	8-155
6.1.7	Cautions for switching J4 mode/J3 compatibility mode.....	8-156
6.1.8	Cautions for the J3 compatibility mode.....	8-156
6.1.9	Change of specifications of "J3 compatibility mode" switching process.....	8-158
6.1.10	J3 extension function.....	8-160
6.2	Master-slave operation function.....	8-162
6.3	Scale measurement function.....	8-166
6.3.1	Functions and configuration.....	8-166
6.3.2	Scale measurement encoder.....	8-168
6.3.3	How to use scale measurement function.....	8-171

Part 9: Review on Replacement of Motor	9- 1 to 9-68
---	---------------------

1.	SERVO MOTOR REPLACEMENT.....	9- 2
1.1	Servo Motor Replacement Model and Compatibility.....	9- 2
2.	COMPARISON OF SERVO MOTOR SPECIFICATIONS.....	9-13
2.1	Comparison of Servo Motor Mounting Dimensions.....	9-13
2.2	Detailed Comparison of Servo Motor Mounting Dimensions.....	9-19
2.3	Comparison of Mounting Dimensions for Geared Servo Motors.....	9-22
2.4	Comparison of Actual Reduction Ratios for Geared Servo Motors.....	9-25
2.5	Comparison of Moment of Inertia.....	9-26
2.6	Comparison of Servo Motor Connector Specifications.....	9-37
2.7	Comparison of Servo Motor Torque Characteristics.....	9-58

Part 10: Review on Replacement of Optional Peripheral Equipment	10- 1 to 10-78
--	-----------------------

1.	COMPARISON TABLE OF REGENERATIVE OPTION COMBINATIONS.....	10- 2
1.1	Regenerative Options 200 V class /100 V class.....	10- 3
1.1.1	Combination and regenerative power for the MR-J3/MR-J3W series.....	10- 3
1.1.2	Combination and regenerative power for MR-J4 series (replacement model).....	10- 4
1.1.3	External Form Comparison.....	10- 5
1.2	Regenerative Options 400 V class.....	10- 6
1.2.1	Combination and regenerative power for the MR-J3 series.....	10- 6
1.2.2	Combination and regenerative power for MR-J4 series (replacement model).....	10- 7
1.2.3	External Form Comparison.....	10- 8
2.	COMPARISON TABLE OF DYNAMIC BRAKE OPTION COMBINATIONS.....	10-10
2.1	External Form Comparison.....	10-11
3.	COMPARISON TABLE OF CABLE OPTION COMBINATIONS.....	10-12

3.1	Changes from MR-J3 series to MR-J4 series	10-12
3.2	Changes from MR-J3W series to MR-J4W2-_B Servo amplifier	10-14
4.	POWER SUPPLY WIRE SIZE.....	10-15
4.1	Selection of Power Supply Wire Size (Example).....	10-15
4.1.1	MR-J3 series power supply wire size	10-15
4.1.2	MR-J4 series power supply wire size	10-19
4.1.3	MR-J3W series power supply wire size	10-21
4.1.4	MR-J4W2-_B servo amplifier, power supply wire size	10-23
4.2	Selection Example of Crimp Terminals	10-25
4.2.1	MR-J3 series crimp terminal	10-25
4.2.2	MR-J4 series crimp terminal	10-26
4.3	Selection of Molded-Case Circuit Breaker, Fuse, and Magnetic Contactor (Example)	10-27
4.3.1	MR-J3 series, molded-case circuit breakers, fuses, and magnetic contactors	10-27
4.3.2	MR-J4 series, molded-case circuit breakers, fuses, and magnetic contactors (recommended).....	10-28
4.3.3	MR-J3W series, no-fuse breakers, fuses, magnetic contactors	10-30
4.3.4	MR-J4W2-_B servo amplifier, no-fuse breakers, fuses, magnetic contactors.....	10-31
5.	BATTERY	10-33
5.1	Combinations of batteries and the servo amplifier	10-33
5.2	MR-J3 series Battery	10-34
5.3	MR-J4 series Battery	10-35
5.3.1	Battery replacement procedure	10-35
5.3.2	When using the MR-BAT6V1SET battery.....	10-36
5.3.3	When using MR-BAT6V1BJ battery for junction battery cable.....	10-37
5.3.4	When using MR-BT6VCASE battery case.....	10-38
5.4	MR-J3W series Battery.....	10-39
5.4.1	MR-BTCASE battery case and MR-BAT battery	10-39
5.5	MR-J4W2-_B servo amplifier, battery.....	10-40
5.5.1	MR-BT6VCASE battery case.....	10-40
5.5.2	MR-BAT6V1 battery.....	10-46
5.5.3	MR-BAT6V1SET-A battery (MR-J4W2-0303B6 only)	10-47
6.	EMC FILTER (RECOMMENDED).....	10-50
6.1	MR-J3/MR-J3W/MR-J4 series EMC Filter (recommended) (100 V/200 V/400 V class)	10-50
6.1.1	Connection example	10-51
6.1.2	Dimensions	10-52
7.	POWER FACTOR IMPROVING AC REACTOR/POWER FACTOR IMPROVING DC REACTOR.....	10-56
7.1	MR-J3 series Power Factor Improving DC Reactor	10-56
7.2	MR-J3/MR-J3W series Power Factor Improving AC Reactor	10-59
7.3	MR-J4 series Power factor improving DC reactors 200 V class.....	10-61
7.4	MR-J4 series Power factor improving DC reactors 400 V class.....	10-63
7.5	MR-J4 series Power factor improving AC reactors 200 V/100 V class	10-65
7.6	MR-J4 series Power factor improving AC reactors 400 V class.....	10-67
8.	SETUP SOFTWARE (SETUP221E)	10-69
8.1	MR-J3/MR-J3W series Setup Software (SETUP221E).....	10-69
8.1.1	Specifications	10-69
8.2	MR-J4 series MR Configurator2	10-70
8.2.1	Specifications.....	10-70
8.3	System configuration	10-71
8.3.1	Components.....	10-71
8.3.2	Connection with servo amplifier	10-72
8.3.3	Precautions for using USB communication function.....	10-72

9. PANEL THROUGH ATTACHMENT	10-73
9.1 MR-J3 series (MR-J3ACN).....	10-73
9.2 MR-J4 series (MR-J4ACN15K/MR-J3ACN).....	10-75

Part 11: Startup Procedure Manual	11- 1 to 11- 4
-----------------------------------	----------------

1. STARTUP	11- 2
1.1 Switching power on for the first time.....	11- 3
1.1.1 Startup procedure	11- 3

Appendix 1: Introduction to Renewal Tool	Appendix 1- 1 to Appendix 1-21
--	--------------------------------

1. SUMMARY.....	Appendix 1- 2
1.1 Servo amplifier replacement model.....	Appendix 1- 2
1.2 Features.....	Appendix 1- 2
2. IMPORTANT POINTS TO NOTE WHEN REPLACING	Appendix 1- 3
3. REPLACEMENT COMBINATION LIST	Appendix 1- 4
3.1 Servo amplifier replacement combination list.....	Appendix 1- 4
3.2 Servo Motor Substitute Model and Compatibility	Appendix 1- 6
4. RENEWAL TOOL PRODUCT LIST.....	Appendix 1- 9
5. SPECIFICATIONS.....	Appendix 1-12
5.1 Standard Specifications.....	Appendix 1-12
6. DIMENSIONS	Appendix 1-13
6.1 Mounting attachment	Appendix 1-13
6.2 Conversion cable	Appendix 1-16
6.2.1 Servo motor side power supply conversion cable	Appendix 1-16
6.2.2 Servo motor side encoder conversion cable	Appendix 1-18
6.2.3 Cable pulling direction	Appendix 1-19
6.2.4 Servo motor side conversion cable for the cooling fan.....	Appendix 1-19
6.2.5 The control signal conversion cable for the servo amplifier side.....	Appendix 1-20

Part 1
Summary of
MR-J3/MR-J3W Replacement

Part 1: Summary of MR-J3/MR-J3W Replacement

This document describes the review items for replacing MR-J3/MR-J3W with MR-J4. Some equipment may require review on items not described in this document. Please review those items after viewing the instruction manual and the catalogs.

Part 1: Summary of MR-J3/MR-J3W Replacement

1. SUMMARY OF MR-J3/MR-J3W REPLACEMENT

In this document, the flow when replacing a system using the MELSERVO "MR-J3" with the "MR-J4 series" is explained.

After deciding the replacement strategy (batch update or partial update of the servo amplifier, servo motor, and controller), please proceed with replacement by referring to the corresponding parts of this manual and the manual for each model.

2. MAJOR REPLACEMENT TARGET MODEL

2.1 Servo Amplifier Replacement Target Model

Series	Servo amplifier model		Series	Servo amplifier Model
MR-J3 series	MR-J3-_A_	→	MR-J4 series	MR-J4-_A_
	MR-J3-_B_			MR-J4-_B_
	MR-J3-_T_ + MR-J3-D01 (Note) (DIO command)			MR-J4-_A_-RJ + MR-D01 (Note)
	MR-J3-_T_ (Serial communication operation)			MR-J4-_A_-RJ
	MR-J3-_T_ (CC-Link communication operation)			MR-J4-_GF_
MR-J3W series	MR-J3W-_B_			MR-J4W2-_B_

Note. MR-J3-D01 and MR-D01 have the same functions and performance. MR-J3-D01 can be used with MR-J4-_A_-RJ.

2.2 Servo Motor Replacement Target Model

		Servo motor model		
Small capacity	Low inertia	HF-KP_	→	HG-KR_
	Ultra-low inertia	HF-MP_		HG-MR_
		HF-MP_ (with reducer)		HG-KR_ (with reducer)
Medium capacity	medium inertia	HF-SP_		HG-SR_
	Low inertia	HC-LP_		HG-JR_
		HF-JP_		HG-RR_
	Ultra-low inertia	HC-RP_		HG-SR_ (with reducer)
		HC-RP_ (with reducer)		HG-UR_
Flat	HC-UP_	HG-SR_		
Large capacity	Low inertia	HA-LP_	HG-JR_	

Note. For details, refer to "Part 9: Review on Replacement of Motor".

Part 1: Summary of MR-J3/MR-J3W Replacement

3. FLOW OF REPLACEMENT

3.1 Summary

This section describes the flow of replacement when replacing a system using the MR-J3 series/MR-J3W series with a system using the MR-J4 series.

3.1.1 Flow of Review on Replacement

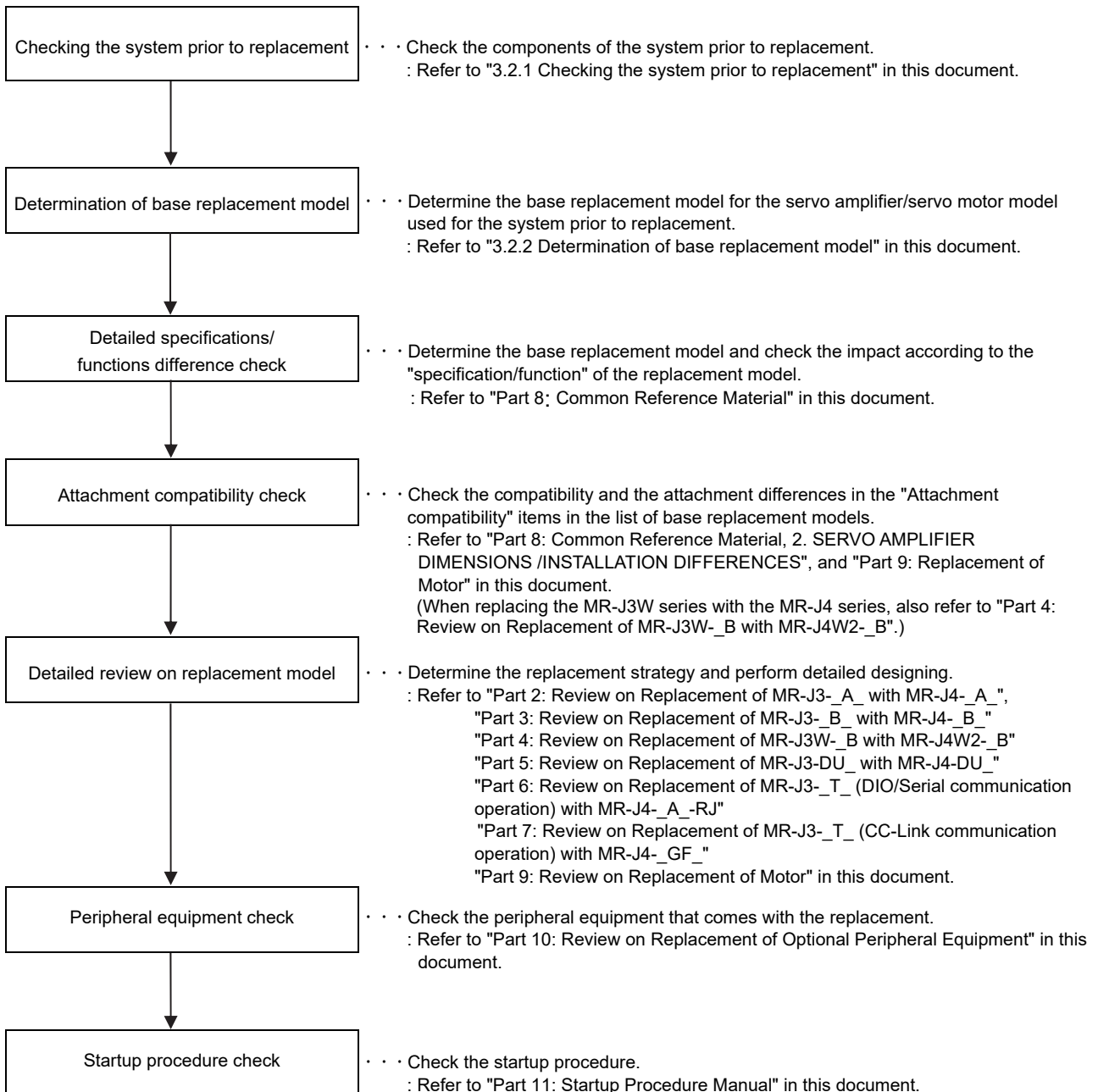

Part 1: Summary of MR-J3/MR-J3W Replacement

3.1.2 Configuration diagram

The following displays the review items when replacing MR-J3 series with MR-J4 series using MR-J3-100A or less as an example case.

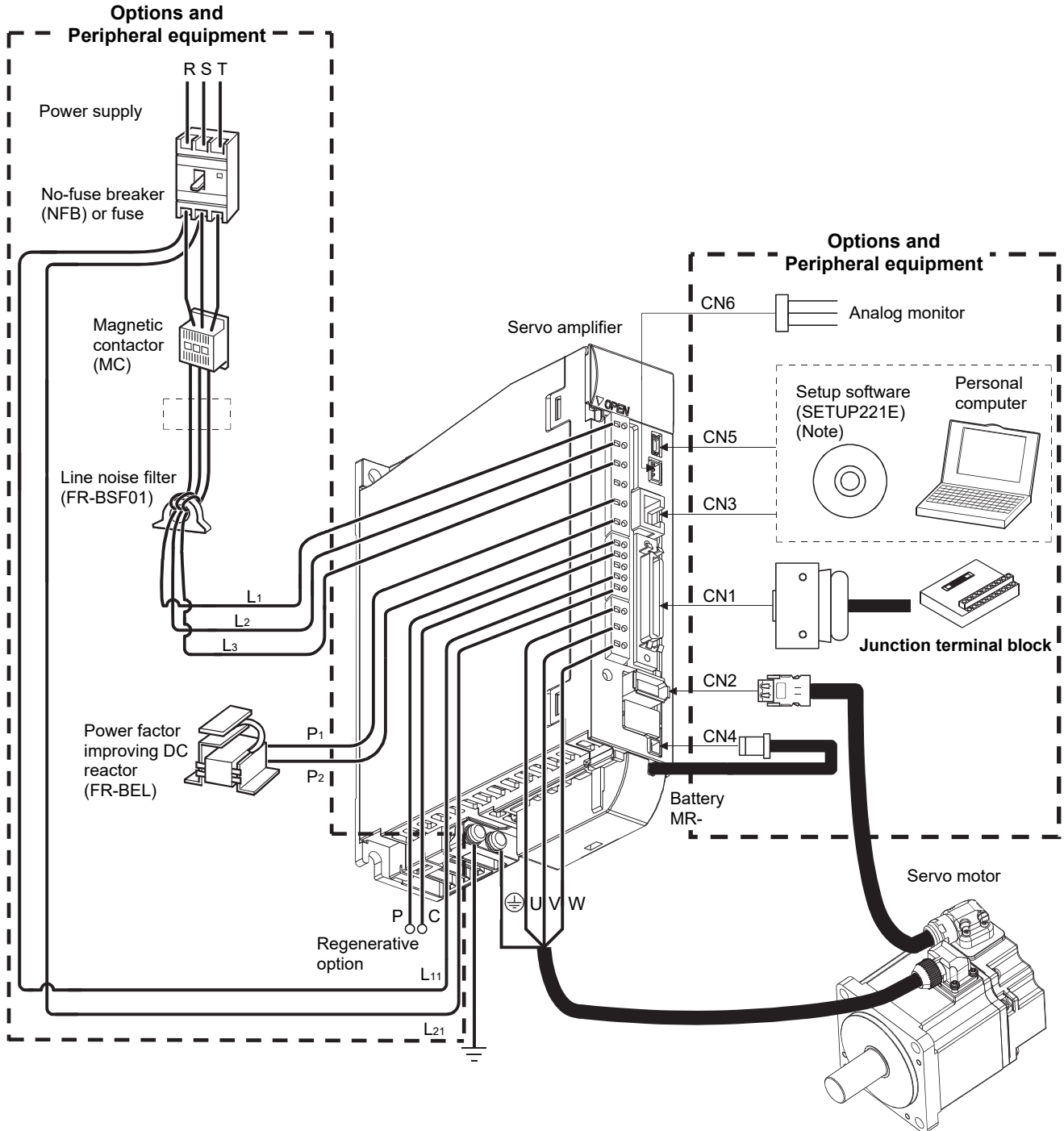

Note. "MR Configurator2" can also be used for MR-J3 series/MR-J3W series.

Part 1: Summary of MR-J3/MR-J3W Replacement

3.1.3 Changes from MR-J3 series to MR-J4 series

POINT
<ul style="list-style-type: none"> ● The following table summarizes the changes from MR-J3 series to MR-J4 series. For details, refer to the reference document/items. ● For large capacity models of 30 kW or more, Refer to "Part 5: Review on Replacement of MR-J3-DU_ with MR-J4-DU_"

Changes	Check items	Impact	Reference document/items
Servo amplifier	Connector	Connector shape, pin arrangement, signal abbreviation, and location are different.	Part 2, Section 3.3 Part 3, Section 3.4 Part 8, Section 1.2.2
	Terminal block	Terminal block shape, location, and method of drawing out wires are different.	Part 8, Section 1.2.1
	P3, P4 terminals	MR-J4 servo amplifier has P3 and P4 in the upstream of the inrush current suppression circuit. Note that the locations of the P1 and P terminals of MR-J3-11K_ to MR-J3-22K_ are different.	Part 8, Section 1.2.1
	Z-phase	There is no difference caused by the replacement from the MR-J3 servo amplifier to the MR-J4 servo amplifier.	Part 8, Section 1.2.7
	Parameter	General-purpose interface is upward compatible, but the parameter needs to be changed. The parameter converter function of MR Configurator2 can transfer the parameter setting for MR-J3 to the setting for MR-J4. For SSCNET III interface, the MR-J3 compatibility mode is available with the MR-J4 series and the parameter does not need to be changed.	Part 2, Section 3.5 Part 3, Section 3.6 Part 8, Section 2.2 Part 8, Section 2.3
	Dimensions	MR-J3 and MR-J4 have compatibility in mounting. Note that the positions (clearances) of mounting screws for the 5 kW (200 V), 3.5 kW (400 V), 11 kW, and 15 kW have been changed to reduce the size of external dimensions.	Part 8, Section 2.1.1 Part 8, Section 2.1.2
	Dynamic brake coasting distance	The servo motor has a different dynamic brake coasting distance.	Part 8, Section 1.2.3
	Forced stop deceleration	For MR-J4, in the shipping status, the servo motor decelerates to stop during a forced stop or when an alarm has occurred. The stop method for MR-J4 is different from the method of when an emergency stop or a forced stop of MR-J3 is enabled.	Part 8, Section 1.2.4 MR-J4-_A_ (-RJ)/MR-J4-03A6(-RJ) Servo Amplifier Instruction Manual MR-J4-_B_ (-RJ) Servo Amplifier Instruction Manual MR-J4-_GF_ Servo Amplifier Instruction Manual (Motion mode)
	Initialization time	The time it takes to reach servo-on from power-on is different.	Part 8, Section 1.2.6
Options and peripheral equipment	Molded-case circuit breaker Fuse	Those for MR-J3 may not be usable. Select those for MR-J4.	Part 10, Section 4.3
	Magnetic contactor	Those for MR-J3 may not be usable. Select those for MR-J4.	Part 10, Section 4.3
	Power factor improving AC reactor	Those for MR-J3 may not be usable. FR-HAL is recommended.	Part 10, Section 7.2 Part 10, Section 7.5 Part 10, Section 7.6
	Power factor improving DC reactor	Those for MR-J3 may not be usable. FR-HEL is recommended.	Part 10, Section 7.1 Part 10, Section 7.3 Part 10, Section 7.4
	Regenerative option	Some regenerative options cannot be used for MR-J4.	Part 10, Chapter 1
	Setup software (SETUP221E)	Setup software (SETUP221E) cannot be used for MR-J4. Use MR Configurator2. "MR Configurator2" can also be used for MR-J4 series and MR-J3 series.	Part 10, Chapter 8
	Battery	Use MR-BAT6V1SET(-A) or MR-BT6VCASE for MR-J4.	Part 10, Chapter 5
	Encoder cable	When more than 15 kW of HG-JR 1000 r/min series or more than 22 kW of HG-JR 1500 r/min series is used, setting changes are required for the following encoder cables. MR-ENECBL _M-H-MTH	Part 8, Section 1.2.2 Part 10, Chapter 3

Part 1: Summary of MR-J3/MR-J3W Replacement

Changes	Check items	Impact	Reference document/items
Options and peripheral equipment	Wire	An HIV wire is recommended for MR-J4.	Part 10, Chapter 4
	Dynamic brakes	Some dynamic brakes cannot be used for MR-J4.	Part 10, Chapter 2
	EMC filter	There is no change in recommended products.	Part 10, Chapter 6
	Panel through attachment	MR-J3ACN cannot be used for MR-J4-11K_(4) or MR-J4-15K_(4).	Part 10, Chapter 9
Servo motor	Mounting compatibility	Some models have no mounting compatibility.	Part 9, Section 1.1
	Dimensions	The total length may differ depending on models.	Part 9, Section 2.1 Part 9, Section 2.2 Part 9, Section 2.3
	Reducer	The actual reduction ratio of HF-KP and HF-MP series G1 types may differ from that of HG-KR series G1 types depending on models.	Part 9, Section 2.3 Part 9, Section 2.4
	Moment of inertia	The moment of inertia of the HF-_P/HC-_P/HA-_P motor may differ from that of the HG motor depending on models. (Note 2)	Part 9, Section 2.5
	Load to motor inertia ratio	The range of the load to motor inertia ratio for the servo motor may differ between the HF-_P/HC-_P/HA-_P motor and the HG motor depending on models.	Part 9, Section 2.5
	Connector	The power connector, encoder connector, and electromagnetic brake connector may differ from one another in shape.	Part 9, Section 2.6
	Torque characteristics	The torque characteristics of the HF-_P/HC-_P/HA-_P motor may differ from those of the HG motor.	Part 9, Section 2.7
	Rated speed/maximum speed	The Rated speed/maximum speed of the HF-_P/HC-_P/HA-_P motor may differ from those of the HG motor.	Servo Motor Instruction Manual (Vol. 3)
	Thermal sensor (Note 1)	For HG-JR 1000 r/min series of 15 kW or more and HG-JR 1500 r/min series of 22 kW or more, the thermal sensor is replaced with a thermistor. For HG-JR 1000 r/min series of 12 kW or less and HG-JR 1500 r/min series of 15 kW or less, the thermal sensor is removed.	HG-MR/HGKR/ HG-SR/HGJR/ HG-RR/HGUR/ HG-AK Servo Motor Instruction Manual (Vol. 3)
	Encoder resolution	The encoder resolution differs as follows. HF-_P/HC-_P/HA-_P motor: 18bit ABS HG motor: 22 bit ABS	HG-MR/HGKR/ HG-SR/HGJR/ HG-RR/HGUR/ HG-AK Servo Motor Instruction Manual (Vol. 3)
Controller (SSCNET III interface only)		MR-J4-_B_ servo amplifiers have two operation modes. "J4 mode" is for using all functions with full performance and "J3 compatibility mode" is compatible with MR-J3-_B_ series for using the amplifiers as the conventional series. When you connect an amplifier with SSCNET III/H communication for the first controller communication with the factory setting, the operation mode will be fixed to "J4 mode". For SSCNET III communication, the operation mode will be fixed to "J3 compatibility mode".	

- Note 1. For HG-JR 1000 r/min series of 15 kW or more and HG-JR 1500 r/min series of 22 kW or more, the thermal sensor is replaced with a thermistor. For HG-JR 1000 r/min series of 12 kW or less and HG-JR 1500 r/min series of 15 kW or less, the thermal sensor is removed. A new encoder cable laying is required because the motor thermal wiring differs.
2. This may change the motor inertia, making it necessary to adjust the servo gain.

Part 1: Summary of MR-J3/MR-J3W Replacement

3.1.4 Changes from MR-J3W series to MR-J4 series

POINT

● The following table summarizes the changes from MR-J3W series to MR-J4 series. For details, refer to the reference document/items.

Changes	Check items	Impact	Reference document/items
Servo amplifier	Connector	Connector shape, pin arrangement, signal abbreviation, and location are different.	Part 4, Section 3.6 Part 8, Section 1.2.2
	Parameter	For SSCNETIII interface, the MR-J3 compatibility mode is available with the MR-J4 series and parameters do not need to be changed.	Part 4, Section 3.7
	Dimensions	MR-J3W-22B/-44B ⇒ MR-J4W2-22B/-44B : The dimensions are the same. The number of mounting screws is different. MR-J3W-77B/-1010B ⇒ MR-J4W2-77B/-1010B : Note that the positions (clearances) and the number of mounting screws have been changed to reduce the size of external dimensions. MR-J3W-0303BN6 ⇒ MR-J4W2-0303B6 : The dimensions, the clearances and number of mounting screw are the same.	Part 8, Section 2.1.5
	Dynamic brake coasting distance	The servo motor has a different dynamic brake coasting distance.	Part 8, Section 1.2.3
	Forced stop deceleration	For MR-J4, in the shipping status, the servo motor decelerates to stop during a forced stop or when an alarm has occurred. The stop method for MR-J4 is different from the method of when an emergency stop or a forced stop of MR-J3W is enabled.	Part 8, Section 1.2.4 MR-J4W2- _B /MR-J4W3- _B /MRJ4W2-0303B6 Servo Amplifier Instruction Manual
	Initialization time	The time it takes to reach servo-on from power-on is different.	Part 8, Section 1.2.6
	Options and peripheral equipment	Molded-case circuit breaker Fuse	Those for MR-J3W may not be usable. Select those for MR-J4.
Magnetic contactor		Those for MR-J3W may not be usable. Select those for MR-J4.	Part 10, Section 4.3
Power factor improving AC reactor		Those for MR-J3W may not be usable. FR-HAL is recommended.	Part 10, Section 7.2 Part 10, Section 7.5
Regenerative option		Some regenerative options cannot be used for MR-J4.	Part 10, Chapter 1
Setup software (SETUP221E)		Setup software (SETUP221E) cannot be used for MR-J4. Use MR Configurator2. "MR Configurator2" can also be used for MR-J4 series and MR-J3W series.	Part 10, Chapter 8
Battery		Use MR-BAT6V1SET(-A) or MR-BT6VCASE for MR-J4.	Part 10, Chapter 5
Encoder cable		MR-J3W cables can be used as they are.	Part 8, Section 1.2.2 Part 10, Chapter 3
Wire		An HIV wire is recommended for MR-J4.	Part 10, Chapter 4
EMC filter		Some EMC filters cannot be used for MR-J4.	Part 10, Chapter 6

Part 1: Summary of MR-J3/MR-J3W Replacement

Changes	Check items	Impact	Reference document/items
Servo motor	Mounting compatibility	Some models have no mounting compatibility.	Part 9, Section 1.1
	Dimensions	The total length may differ depending on models.	Part 9, Section 2.1 Part 9, Section 2.2 Part 9, Section 2.3
	Reducer	The actual reduction ratio of HF-KP and HF-MP series G1 types may differ from that of HG-KR series G1 types depending on models.	Part 9, Section 2.3 Part 9, Section 2.4
	Moment of inertia	The moment of inertia of the HF-_P/HC-_P/HA-_P motor may differ from that of the HG motor depending on models. (Note)	Part 9, Section 2.5
	Load to motor inertia ratio	The range of the load to motor inertia ratio for the servo motor may differ between the HF-_P/HC-_P motor and the HG motor depending on models.	Part 9, Section 2.5
	Connector	The power connector, encoder connector, and electromagnetic brake connector may differ from one another in shape.	Part 9, Section 2.6
	Torque characteristics	The torque characteristics of the HF-_P/HC-_P motor may differ from those of the HG motor.	Part 9, Section 2.7
	Rated speed/maximum speed	The Rated speed/maximum speed of the HF-_P/HC-_P motor may differ from those of the HG motor.	HG-MR/HGKR/ HG-SR/HGJR/ HG-RR/HGUR/ HG-AK Servo Motor Instruction Manual (Vol. 3)
	Encoder resolution	The encoder resolution differs as follows. HF-_P/HC-_P motor: 18bit ABS HG motor: 22 bit ABS	HG-MR/HGKR/ HG-SR/HGJR/ HG-RR/HGUR/ HG-AK Servo Motor Instruction Manual (Vol. 3)
Controller (SSCNET interface only)		MR-J4W2-_B servo amplifiers have two operation modes. "J4 mode" is for using all functions with full performance and "J3 compatibility mode" is compatible with MR-J3W-_B series for using the amplifiers as the conventional series. When you connect an amplifier with SSCNET III/H communication for the first controller communication with the factory setting, the operation mode will be fixed to "J4 mode". For SSCNET III communication, the operation mode will be fixed to "J3 compatibility mode".	

Note. This may change the motor inertia, making it necessary to adjust the servo gain.

Part 1: Summary of MR-J3/MR-J3W Replacement

3.2 Review on replacement

3.2.1 Checking the system prior to replacement

Check the components of the system prior to replacement.

Category	Controller model	Servo amplifier model	"Reference items" in this document	Control mode
Positioning module	QD75P(D)	MR-J3-_A_	⇒	Position control
	A1SD75P(D)			
Controller from another company	Controller from another company	MR-J3-_A_	⇒	Speed control Torque control Positioning mode (Point table method)
No controller connected	No controller	MR-J3-_A_	⇒	
		MR-J3-_T_ + MR-J3-D01 (DIO/Serial communication)	⇒	
SSCNET III Positioning module	QD75MH	MR-J3-_B_ MR-J3W-_B	⇒	Position control
SSCNET III Motion controller	Q17_HCPU	MR-J3-_B_ MR-J3W-_B	⇒	
	Q170MCP Q17_DCPU		⇒	
CC-Link master/local module	QJ61BT11N	MR-J3-_T_ (CC-Link communication)	⇒	Positioning mode (Point table method, Indexer method) Speed control (Point table method)
	A1SJ61QBT11			
	A1SJ61BT11			

Part 1: Summary of MR-J3/MR-J3W Replacement

3.2.2 Determination of base replacement model

(1) Models for replacement between MR-J3 series and MR-J4 series

Shown below are the base replacement models with the assumption that both the servo amplifier and servo motor will be replaced as a set.

(a) General-purpose interface 200 V class

Model	Replacement model (example)	Attachment compatibility (○: Compatible)	Check items
MR-J3-10A	MR-J4-10A	○	Refer to "Part 8: Common Reference Material".
MR-J3-20A	MR-J4-20A	○	
MR-J3-40A	MR-J4-40A	○	
MR-J3-60A	MR-J4-60A	○	
MR-J3-70A	MR-J4-70A	○	
MR-J3-100A	MR-J4-100A	○	
MR-J3-200A(N)(-RT)	MR-J4-200A	○	
MR-J3-350A	MR-J4-350A	○	
MR-J3-500A	MR-J4-500A	(Note)	
MR-J3-700A	MR-J4-700A	○	
MR-J3-11KA	MR-J4-11KA	(Note)	
MR-J3-11KA-LR			
MR-J3-15KA	MR-J4-15KA	(Note)	
MR-J3-15KA-LR			
MR-J3-22KA	MR-J4-22KA	○	

Note. Refer to Comparison of servo amplifier dimensions (Part 8 Common Reference Material) for dimensions of mounting holes.

(b) SSCNET interface 200 V class

Model	Replacement model (example)	Attachment compatibility (○: Compatible)	Check items
MR-J3-10B	MR-J4-10B	○	Refer to "Part 8: Common Reference Material".
MR-J3-20B	MR-J4-20B	○	
MR-J3-40B	MR-J4-40B	○	
MR-J3-60B	MR-J4-60B	○	
MR-J3-70B	MR-J4-70B	○	
MR-J3-100B	MR-J4-100B	○	
MR-J3-200B(N)(-RT)	MR-J4-200B	○	
MR-J3-350B	MR-J4-350B	○	
MR-J3-500B	MR-J4-500B	(Note)	
MR-J3-700B	MR-J4-700B	○	
MR-J3-11KB	MR-J4-11KB	(Note)	
MR-J3-11KB-LR			
MR-J3-15KB	MR-J4-15KB	(Note)	
MR-J3-15KB-LR			
MR-J3-22KB	MR-J4-22KB	○	

Note. Refer to Comparison of servo amplifier dimensions (Part 8 Common Reference Material) for dimensions of mounting holes.

Part 1: Summary of MR-J3/MR-J3W Replacement

(c) DIO/Serial communication 200 V class

Model	Replacement model (example)	Attachment compatibility (O: Compatible)	Check items
MR-J3-10T	MR-J4-10A-RJ	○	Refer to "Part 8: Common Reference Material".
MR-J3-20T	MR-J4-20A-RJ	○	
MR-J3-40T	MR-J4-40A-RJ	○	
MR-J3-60T	MR-J4-60A-RJ	○	
MR-J3-70T	MR-J4-70A-RJ	○	
MR-J3-100T	MR-J4-100A-RJ	○	
MR-J3-200TN	MR-J4-200A-RJ	○	
MR-J3-350T	MR-J4-350A-RJ	○	
MR-J3-500T	MR-J4-500A-RJ	(Note)	
MR-J3-700T	MR-J4-700A-RJ	○	
MR-J3-11KT	MR-J4-11KA-RJ	(Note)	
MR-J3-15KT	MR-J4-15KA-RJ	(Note)	
MR-J3-22KT	MR-J4-22KA-RJ	○	

Note. Refer to Comparison of servo amplifier dimensions (Part 8 Common Reference Material) for dimensions of mounting holes.

(d) CC-Link ⇒ CC-Link IE Field Network interface 200 V class

Model	Replacement model (example)	Attachment compatibility (O: Compatible)	Check items
MR-J3-10T	MR-J4-10GF	(Note)	Refer to "Part 8: Common Reference Material".
MR-J3-20T	MR-J4-20GF	(Note)	
MR-J3-40T	MR-J4-40GF	(Note)	
MR-J3-60T	MR-J4-60GF	(Note)	
MR-J3-70T	MR-J4-70GF	○	
MR-J3-100T	MR-J4-100GF	○	
MR-J3-200TN	MR-J4-200GF	○	
MR-J3-350T	MR-J4-350GF	○	
MR-J3-500T	MR-J4-500GF	(Note)	
MR-J3-700T	MR-J4-700GF	○	
MR-J3-11KT	MR-J4-11KGF	(Note)	
MR-J3-15KT	MR-J4-15KGF	(Note)	
MR-J3-22KT	MR-J4-22KGF	○	

Note. Refer to Comparison of servo amplifier dimensions (Part 8 Common Reference Material) for dimensions of mounting holes.

(e) General-purpose interface 200 V class (30 kW or more)

Model	Replacement model (example)	Attachment compatibility (O: Compatible)	Check items
MR-J3-DU30KA + MR-J3-CR55K	MR-J4-DU30KA + MR-CR55K	○	Refer to "Part 5: Review on Replacement of MR-J3-DU_ with MR-J4-DU_".
MR-J3-DU37KA + MR-J3-CR55K	MR-J4-DU37KA + MR-CR55K	○	

(f) SSCNET interface 200 V class (30 kW or more)

Model	Replacement model (example)	Attachment compatibility (O: Compatible)	Check items
MR-J3-DU30KB + MR-J3-CR55K	MR-J4-DU30KB + MR-CR55K	○	Refer to "Part 5: Review on Replacement of MR-J3-DU_ with MR-J4-DU_".
MR-J3-DU37KB + MR-J3-CR55K	MR-J4-DU37KB + MR-CR55K	○	

Part 1: Summary of MR-J3/MR-J3W Replacement

(g) General-purpose interface 400 V class

Model	Replacement model (example)	Attachment compatibility (O: Compatible)	Check items
MR-J3-60A4	MR-J4-60A4	○	Refer to "Part 8: Common Reference Material".
MR-J3-100A4	MR-J4-100A4	○	
MR-J3-200A4	MR-J4-200A4	○	
MR-J3-350A4	MR-J4-350A4	(Note)	
MR-J3-500A4	MR-J4-500A4	○	
MR-J3-700A4	MR-J4-700A4	○	
MR-J3-11KA4	MR-J4-11KA4	(Note)	
MR-J3-11KA4-LR			
MR-J3-15KA4	MR-J4-15KA4	(Note)	
MR-J3-15KA4-LR			
MR-J3-22KA4	MR-J4-22KA4	○	

Note. Refer to Comparison of servo amplifier dimensions (Part 8 Common Reference Material) for dimensions of mounting holes.

(h) SSCNET interface 400 V class

Model	Replacement model (example)	Attachment compatibility (O: Compatible)	Check items
MR-J3-60B4	MR-J4-60B4	○	Refer to "Part 8: Common Reference Material".
MR-J3-100B4	MR-J4-100B4	○	
MR-J3-200B4	MR-J4-200B4	○	
MR-J3-350B4	MR-J4-350B4	(Note)	
MR-J3-500B4	MR-J4-500B4	○	
MR-J3-700B4	MR-J4-700B4	○	
MR-J3-11KB4	MR-J4-11KB4	(Note)	
MR-J3-11KB4-LR			
MR-J3-15KB4	MR-J4-15KB4	(Note)	
MR-J3-15KB4-LR			
MR-J3-22KB4	MR-J4-22KB4	○	

Note. Refer to Comparison of servo amplifier dimensions (Part 8 Common Reference Material) for dimensions of mounting holes.

(i) DIO/Serial communication 400 V class

Model	Replacement model (example)	Attachment compatibility (O: Compatible)	Check items
MR-J3-60T4	MR-J4-60A4-RJ	○	Refer to "Part 8: Common Reference Material".
MR-J3-100T4	MR-J4-100A4-RJ	○	
MR-J3-200T4	MR-J4-200A4-RJ	○	
MR-J3-350T4	MR-J4-350A4-RJ	(Note)	
MR-J3-500T4	MR-J4-500A4-RJ	○	
MR-J3-700T4	MR-J4-700A4-RJ	○	
MR-J3-11KT4	MR-J4-11KA4-RJ	(Note)	
MR-J3-15KT4	MR-J4-15KA4-RJ	(Note)	
MR-J3-22KT4	MR-J4-22KA4-RJ	○	

Note. Refer to Comparison of servo amplifier dimensions (Part 8 Common Reference Material) for dimensions of mounting holes.

Part 1: Summary of MR-J3/MR-J3W Replacement

(j) CC-Link ⇒ CC-Link IE Field Network interface 400 V class

Model	Replacement model (example)	Attachment compatibility (O: Compatible)	Check items
MR-J3-60T4	MR-J4-60GF4	○	Refer to "Part 8: Common Reference Material".
MR-J3-100T4	MR-J4-100GF4	○	
MR-J3-200T4	MR-J4-200GF4	○	
MR-J3-350T4	MR-J4-350GF4	(Note)	
MR-J3-500T4	MR-J4-500GF4	○	
MR-J3-700T4	MR-J4-700GF4	○	
MR-J3-11KT4	MR-J4-11KGF4	(Note)	
MR-J3-15KT4	MR-J4-15KGF4	(Note)	
MR-J3-22KT4	MR-J4-22KGF4	○	

Note. Refer to Comparison of servo amplifier dimensions (Part 8 Common Reference Material) for dimensions of mounting holes.

(k) General-purpose interface 400 V class (30 kW or more)

Model	Replacement model (example)	Attachment compatibility (O: Compatible)	Check items
MR-J3-DU30KA4 + MR-J3-CR55K4	MR-J4-DU30KA4 + MR-CR55K4	○	Refer to "Part 5: Review on Replacement of MR-J3-DU_ with MR-J4-DU_"
MR-J3-DU37KA4 + MR-J3-CR55K4	MR-J4-DU37KA4 + MR-CR55K4	○	
MR-J3-DU45KA4 + MR-J3-CR55K4	MR-J4-DU45KA4 + MR-CR55K4	○	
MR-J3-DU55KA4 + MR-J3-CR55K4	MR-J4-DU55KA4 + MR-CR55K4	○	

(l) SSCNET interface 400 V class (30 kW or more)

Model	Replacement model (example)	Attachment compatibility (O: Compatible)	Check items
MR-J3-DU30KB4 + MR-J3-CR55K4	MR-J4-DU30KB4 + MR-CR55K4	○	Refer to "Part 5: Review on Replacement of MR-J3-DU_ with MR-J4-DU_"
MR-J3-DU37KB4 + MR-J3-CR55K4	MR-J4-DU37KB4 + MR-CR55K4	○	
MR-J3-DU45KB4 + MR-J3-CR55K4	MR-J4-DU45KB4 + MR-CR55K4	○	
MR-J3-DU55KB4 + MR-J3-CR55K4	MR-J4-DU55KB4 + MR-CR55K4	○	

(m) General-purpose interface 100 V class

Model	Replacement model (example)	Attachment compatibility (O: Compatible)	Check items
MR-J3-10A1	MR-J4-10A1	○	Refer to "Part 8: Common Reference Material".
MR-J3-20A1	MR-J4-20A1	○	
MR-J3-40A1	MR-J4-40A1	○	

(n) SSCNET interface 100 V class

Model	Replacement model (example)	Attachment compatibility (O: Compatible)	Check items
MR-J3-10B1	MR-J4-10B1	○	Refer to "Part 8: Common Reference Material".
MR-J3-20B1	MR-J4-20B1	○	
MR-J3-40B1	MR-J4-40B1	○	

Part 1: Summary of MR-J3/MR-J3W Replacement

(o) DIO/Serial communication 100 V class

Model	Replacement model (example)	Attachment compatibility (O: Compatible)	Check items
MR-J3-10T1	MR-J4-10A1-RJ	○	Refer to "Part 8: Common Reference Material".
MR-J3-20T1	MR-J4-20A1-RJ	○	
MR-J3-40T1	MR-J4-40A1-RJ	○	

(p) CC-Link ⇒ CC-Link IE Field Network interface 100 V class

Model	Replacement model (example)	Attachment compatibility (O: Compatible)	Check items
MR-J3-10T1	MR-J4-10A1-RJ	○	Refer to "Part 8: Common Reference Material".
MR-J3-20T1	MR-J4-20A1-RJ	○	
MR-J3-40T1	MR-J4-40A1-RJ	○	

Part 1: Summary of MR-J3/MR-J3W Replacement

(2) Models for replacement between MR-J3W series and MR-J4 series

Shown below are the base replacement models with the assumption that both the servo amplifier and servo motor will be replaced as a set.

(a) SSCNET interface 200 V class

Model	Replacement model (example)	Attachment compatibility (O: Compatible)	Check items
MR-J3W-22B	MR-J4W2-22B	(Note 1)	Refer to "Part 4: Review on Replacement of MR-J3W-_B with MR-J4W2-_B"
MR-J3W-44B	MR-J4W2-44B	(Note 1)	
MR-J3W-77B	MR-J4W2-77B	(Note 2)	
MR-J3W-1010B	MR-J4W2-1010B	(Note 2)	

Note 1. The dimensions are the same. The number of mounting screws is different.

2. Note that the positions (clearances) and the number of mounting screws have been changed to reduce the size of external dimensions.

(b) SSCNET interface 48 V DC/24 V DC class

Model	Replacement model (example)	Attachment compatibility (O: Compatible)	Check items
MR-J3W-0303BN6	MR-J4W2-0303B6	○	Refer to "Part 4: Review on Replacement of MR-J3W-_B with MR-J4W2-_B"

Part 1: Summary of MR-J3/MR-J3W Replacement

(3) Servo amplifier and servo motor combination for the MR-J4 series

For a review on the replacement of an existing servo motor with a new one, Refer to "Part 9: Review on Replacement of Motor".

(a) 200 V/100 V class

Servo amplifier	Rotary servo motor					
	HG-KR	HG-MR	HG-SR	HG-UR	HG-RR	HG-JR
MR-J4-10_(-RJ)	053 13	053 13				
MR-J4-20_(-RJ)	23	23				
MR-J4-40_(-RJ)	43	43				
MR-J4-60_(-RJ)			51 52			53
MR-J4-70_(-RJ)	73	73		72		73
MR-J4-100_(-RJ)			81 102			53 (Note) 103
MR-J4-200_(-RJ)			121 201 152 202	152	103 153	73 (Note) 103 (Note) 153 203
MR-J4-350_(-RJ)			301 352	202	203	153 (Note) 203 (Note) 353
MR-J4-500_(-RJ)			421 502	352 502	353 503	353 (Note) 503
MR-J4-700_(-RJ)			702			503 (Note) 601 701M 703
MR-J4-11K_(-RJ)						801 12K1 11K1M 903
MR-J4-15K_(-RJ)						15K1 15K1M
MR-J4-22K_(-RJ)						20K1 25K1 22K1M
MR-J4-DU30K_						30K1 30K1M
MR-J4-DU37K_						37K1 37K1M
MR-J4W2-22B	053 13 23	053 13 23				
MR-J4W2-44B	053 13 23 43	053 13 23 43				
MR-J4W2-77B	43 73	43 73	51 52	72		53 73
MR-J4W2-1010B	43 73	43 73	51 81 52 102	72		53 (Note) 73 103

Note. With this combination, the rated torque and maximum torque can be increased.

Part 1: Summary of MR-J3/MR-J3W Replacement

(b) 400 V class

Servo amplifier	Rotary servo motor	
	HG-SR	HG-JR
MR-J4-60_4(-RJ)	524	534
MR-J4-100_4(-RJ)	1024	534 (Note) 734 1034
MR-J4-200_4(-RJ)	1524 2024	734 (Note) 1034 (Note) 1534 2034
MR-J4-350_4(-RJ)	3524	1534 (Note) 2034 (Note) 3534
MR-J4-500_4(-RJ)	5024	3534 (Note) 5034
MR-J4-700_4(-RJ)	7024	5034 (Note) 6014 701M4 7034
MR-J4-11K_4(-RJ)	/	8014 12K14 11K1M4 9034
MR-J4-15K_4(-RJ)		15K14 15K1M4
MR-J4-22K_4(-RJ)		20K14 25K14 22K1M4
MR-J4-DU30K_4		30K14 30K1M4
MR-J4-DU37K_4	/	37K14 37K1M4
MR-J4-DU45K_4	/	45K1M4
MR-J4-DU55K_4	/	55K1M4

Note. With this combination, the rated torque and maximum torque can be increased.

(c) 48 V DC/24 V DC class

Servo amplifier	Rotary servo motor
	HG-AK
MR-J4W2-0303B6	0136
	0236
	0336

Part 1: Summary of MR-J3/MR-J3W Replacement

3.2.3 Attachment compatibility check

Refer to "Part 8: Common Reference Material" and "Part 9: Review on Replacement of Motor".

3.2.4 Detailed review on replacement model

Refer to "Part 2: Review on Replacement of MR-J3-_A_ with MR-J4-_A_", "Part 3: Review on Replacement of MR-J3-_B_ with MR-J4-_B_", "Part 4: Review on Replacement of MR-J3W-_B_ with MR-J4W2-_B_", "Part 5: Review on Replacement of MR-J3-DU_ with MR-J4-DU_", "Part 6: Review on Replacement of MR-J3-_T_(DIO/Serial communication operation) with MR-J4-_A_-RJ" and "Part 7: Review on Replacement of MR-J3-_T_(CC-Link communication operation) with MR-J4-_GF_".

3.2.5 Peripheral equipment check

Refer to "Part 10: Review on Replacement of Optional Peripheral Equipment" in this document.

3.2.6 Startup procedure check

Refer to "Part 11: Startup Procedure Manual" in this document.

4. RELATED MATERIALS

4.1 Catalog

- (1) Mitsubishi Electric General-Purpose AC Servo MELSERVO-J4
- (2) Motion Controller Q17nDSCPU/Q170MSCPU

4.2 Instruction Manual

- (1) MR-J4-_A_(-RJ)/MR-J4-03A6(-RJ) Servo Amplifier Instruction Manual (SH(NA)030113)
- (2) MR-J4-_B_(-RJ) Servo Amplifier Instruction Manual (SH(NA)030106)
- (3) MR-J4W2-_B_/MR-J4W3-_B_/MR-J4W2-0303B6 Servo Amplifier Instruction Manual (SH(NA)030105)
- (4) MR-CV_/MR-CR55K_/MR-J4-DU_B_(-RJ)/MR-J4-DU_A_(-RJ) Instruction Manual (SH(NA)030153)
- (5) MR-J4-_A_-RJ/MR-J4-03A6-RJ Servo Amplifier Instruction Manual (Positioning Mode) (SH(NA)030143)
- (6) HG-MR/HG-KR/HG-SR/HG-JR/HG-RR/HG-UR/HG-AK Servo Motor Instruction Manual (Vol. 3) (SH(NA)030113)
- (7) MR-J4 Servo Amplifier Instruction Manual (Troubleshooting) (SH(NA)030109)
- (8) MR-J4-_GF_(-RJ) Servo Amplifier Instruction Manual (Motion Mode) (SH(NA)030218)
- (9) MR-J4-_GF_(-RJ) Servo Amplifier Instruction Manual (I/O Mode) (SH(NA)030221)

Part 1: Summary of MR-J3/MR-J3W Replacement

4.3 Migration Guide

- (1) Migration Guide of Motion Controller [Q17nCPUN(-T) ⇒ RnMTCPU] (L(NA)03156)
- (2) Migration Guide of Motion Controller [Q17nHCPU(-T) ⇒ RnMTCPU] (L(NA)03157)
- (3) Migration Guide from Positioning Module to Simple Motion Module [QD75M(H) ⇒ RD77MS] (L(NA)03158)
- (4) Migration Guide from Positioning Module to Simple Motion Module [QD74MH ⇒ RD77MS] (L(NA)03170ENG)
- (5) Migration Guide of Motion Controller [Q17nDCPU(-S1) ⇒ Q17nDSCPU] (L(NA)03189ENG)
- (6) Migration Guide of Motion Controller [Q17nHCPU(-T) ⇒ Q17nDSCPU] (L(NA)03184ENG)
- (7) Migration Guide of Motion Controller [Q17nCPUN(-T) ⇒ Q17nDSCPU] (L(NA)03121ENG)
- (8) Migration Guide from Positioning Module to Simple Motion Module [QD75M(H) ⇒ QD77MS] (L(NA)03122ENG)
- (9) Migration Guide from Positioning Module to Simple Motion Module [QD74MH ⇒ QD77MS] (L(NA)03165ENG)
- (10) Motion controller Replacement Virtual mode with Advanced synchronous control (L(NA)03123ENG)
- (11) Transition from A17nSHCPUN/A173UHCPU Series to Q Series Handbook (L(NA)03104)

4.4 Replacement Tool for Replacing MR-J3 with MR-J4

This tool is a reference for replacing the in-use MR-J3 series with the MR-J4 series.

The replacement tool is available on the Mitsubishi Electric FA site.

When an in-use rotary servo motor or servo amplifier is selected, a corresponding MR-J4 series product can be selected.

- Note
1. Use the results as just a reference. Refer to catalogs or instruction manuals. For details, contact your local sales office.
 2. MR-J3W series is not compatible.

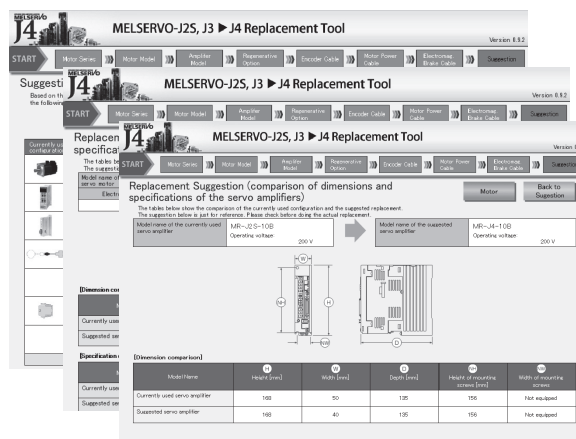
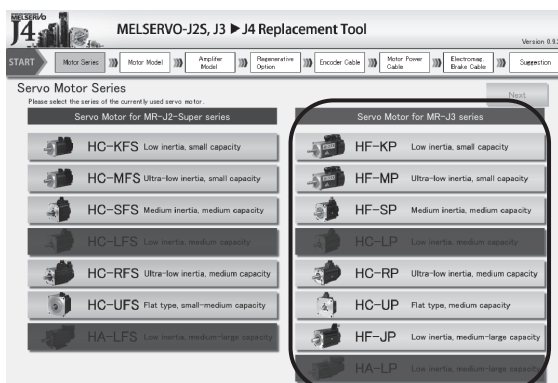

Servo motor series model, servo amplifier model, regenerative option, encoder motor power supply, and electromagnetic brake selection

Selection result configuration, servo motor dimensions/specification comparison, servo amplifier dimensions/specification comparison

Part 1: Summary of MR-J3/MR-J3W Replacement

4.5 MITSUBISHI ELECTRIC FA Global Website

<http://www.mitsubishielectric.com/fa/>

Part 2

Review on Replacement of

MR-J3- _A_ with MR-J4- _A_

Part 2: Review on Replacement of MR-J3- _A_ with MR-J4- _A_

Part 2: Review on Replacement of MR-J3- _A_ with MR-J4- _A_

1. SUMMARY

This section describes the changes to be made when a system using MR-J3- _A_ is replaced with a system using MR-J4- _A_.

2. CASE STUDY ON REPLACEMENT OF MR-J3- _A_

2.1 Review on Replacement Method

POINT
<ul style="list-style-type: none"> ● An HG motor cannot be driven by MR-J3- _A_ . When a servo motor is replaced with an HG motor, servo amplifier also needs to be replaced with MR-J4- _A_ simultaneously.

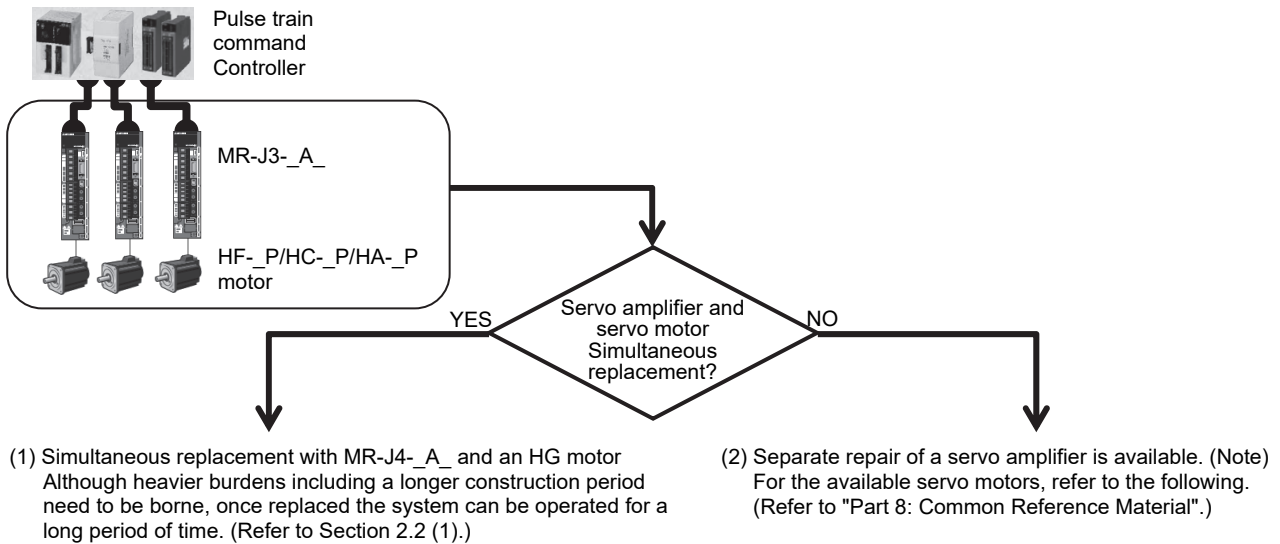

Note. Separate repair means replacement.

2.2 Replacement Method

(1) Simultaneous replacement with MR-J4- _A_ and an HG motor

The currently used connectors or cables need to be replaced. The parameters of the existing system can be transferred with the parameter converter function of MR Configurator2. (Refer to "Part 8: Common Reference Material".)

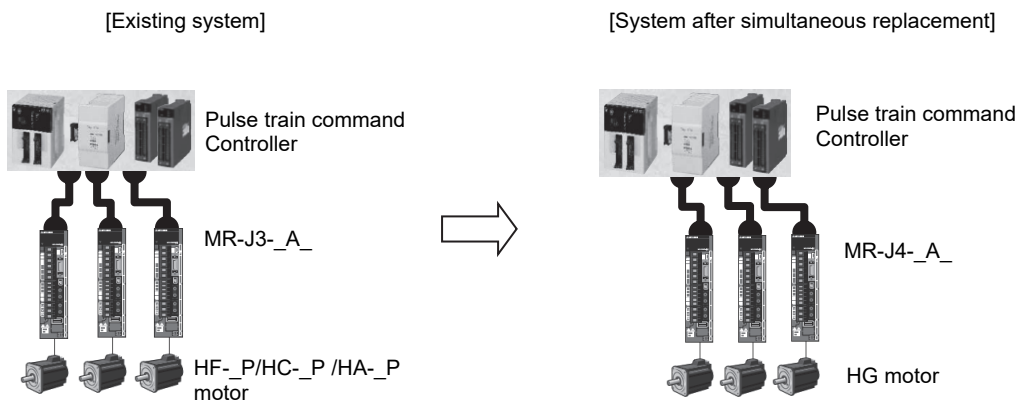

Part 2: Review on Replacement of MR-J3- _A_ with MR-J4- _A_

(2) Separate repair of servo amplifiers and servo motors

POINT			
<ul style="list-style-type: none"> ● An HG motor cannot be driven by MR-J3- _A_. When a servo motor is replaced with an HG motor, servo amplifier also needs to be replaced with MR-J4- _A_ simultaneously. ● If the existing system is any of the combinations in the following table, it is recommended to replace both the servo amplifier and servo motor with an MR-J4- _A_ and HG motor at the same time. When an HG motor is adopted, the capacity of the servo amplifier needs to be changed. (Consider replacement, referring to "torque characteristics" described in "Part 9: Replacement of Motor".) ● The low inertia "HG-JR motor" is recommended for the replacement of "HC-LP motor". 			
<p>To use a servo motor other than the motors listed in following table, check the compatibility with the equipment because the motor inertia, etc. is different.</p>			
Existing device models		Replacement models for simultaneous replacement (example)	
Servo motor	Servo amplifier	Servo motor	Servo amplifier
HC-RP103(B)G5 1/_	MR-J3-200A(N)(-RT)	HG-SR102(B)G5 1/_	MR-J4-100A
HC-RP203(B)G5 1/_	MR-J3-350A	HG-SR202(B)G5 1/_	MR-J4-200A
HC-RP353(B)G5 1/_	MR-J3-500A	HG-SR352(B)G5 1/_	MR-J4-350A
HC-RP103(B)G7 1/_	MR-J3-200A(N)(-RT)	HG-SR102(B)G7 1/_	MR-J4-100A
HC-RP203(B)G7 1/_	MR-J3-350A	HG-SR202(B)G7 1/_	MR-J4-200A
HC-RP353(B)G7 1/_	MR-J3-500A	HG-SR352(B)G7 1/_	MR-J4-350A
HC-LP52(B)	MR-J3-60A	HG-JR73(B)	MR-J4-70A
HC-LP102(B)	MR-J3-100A	HG-JR153(B)	MR-J4-200A
HC-LP152(B)	MR-J3-200A(N)(-RT)	HG-JR353(B)	MR-J4-350A

Replacement of servo amplifier	Replacement of servo motor
<p>Pulse train command Controller</p> <p>MR-J4- _A_</p> <p>MR-J3- _A_</p> <p>MR-J3- _A_</p> <p>MR-J3- _A_</p> <p>HF- _P_/HC- _P_/HA- _P_ motor</p>	<p>Pulse train command Controller</p> <p>MR-J4- _A_</p> <p>MR-J3- _A_</p> <p>MR-J3- _A_</p> <p>MR-J3- _A_</p> <p>HF- _P_/HC- _P_/HA- _P_ motor</p> <p>HG motor</p> <p>HF- _P_/HC- _P_/HA- _P_ motor</p>
<p>Replacing the system allows the J3 series servo motors to drive in MR-J4- _A_. Refer to "Part 8: Common Reference Material" for target motors.</p>	<p>The HG motor cannot be driven by MR-J3- _A_. When a servo motor is replaced with an HG motor, servo amplifier also needs to be replaced with MR-J4- _A_ simultaneously.</p>

Part 2: Review on Replacement of MR-J3- _A_ with MR-J4- _A_

3. DIFFERENCES BETWEEN MR-J3- _A_ AND MR-J4- _A_

3.1 Function Comparison Table

POINT
● Functions with difference are shown with shading.

(1) 200 V class

Item	MR-J3 series	MR-J4 series
1	Capacity range	0.1 kW to 22 kW/200 V
2	Internal regenerative resistor	Built-in (0.2 kW to 7 kW) External (11kW to 22 kW)
3	Dynamic brake	Built-in (0.1kW to 7kW) External (11kW to 22 kW) Coasting distance may differ. (Note 1)
4	Control circuit power	1-phase 200 V AC to 230 V AC
5	Main circuit power	1-phase 200 V AC to 230 V AC (0.1 kW to 0.75 kW) 3-phase 200 V AC to 230 V AC (0.1 kW to 22 kW)
6	24 V DC power	External supply required
7	Auto Tuning	Real-time auto tuning: 32 steps Advanced gain search
8	Control mode	Real-time auto tuning: 40 steps One-touch tuning
9	Maximum input pulses	Differential pulse: 1 Mpulse/s Open-collector pulse: 200 kpulses/s Command pulse: Sink
10	The number of DIO points (excluding EM1)	Differential pulse: 4 Mpulses/s Open-collector pulse: 200 kpulses/s Command pulse: Sink
11	Encoder pulse output	DI: 9 points, DO: 6 points
12	DIO interface	A/B/Z-phase pulse (differential line driver) Z-phase pulse (open collector)
13	Analog input/output	input/output: sink/source
14	Number of internal speed commands	(Input) 2ch 10-bit torque, 14-bit speed or equivalent (Output) 10-bit or equivalent × 2ch
15	Parameter setting method	(Input) 2ch 10-bit torque, 14-bit speed or equivalent (Output) 10-bit or equivalent × 2ch
16	Setup software communication function	7 points
17	Servo motor (Encoder resolution)	Setup software (SETUP221E) MR Configurator2 Push button
18	Motor maximum torque	MR Configurator2 Push button
19	LED display	USB
20	Advanced vibration suppression control	HF- _P series (18-bit ABS) HA- _P series (18-bit ABS)
21	Adaptive filter II	HG series (22 -bit ABS)
22	Notch filter	HF-KP 350% HF-MP 300% HF-SP 300% HF-JP 300% HA-LP 250%
23	Tough drive	HG-KR 350% HG-MR 300% HG-SR 300% HG-JR 300% HG-JR 300%
24	Drive recorder	7-segment 5-digit
25	Forced stop	Provided (Advanced vibration suppression control II)
		Provided
		Provided (2 pcs)
		Unprovided
		Provided
		Unprovided
		EM1 (DB stop)
		EM1 (DB stop)/EM2 (deceleration to a stop)

Note 1. For the coasting distance, refer to "1.2.3 Dynamic brake: coasting distance" in "Part 8 Common Reference Material".

- If using a 1-phase 200 V AC to 240 V AC power supply with a 1 kW/2 kW servo amplifier, operate the servo amplifier at 75% or less of the effective load ratio.

Part 2: Review on Replacement of MR-J3- _A_ with MR-J4- _A_

(2) 400 V class

Item		MR-J3 series	MR-J4 series
1	Capacity range	0.6 kW to 22 kW/400 V	0.6 to 22 kW/400 V
2	Internal regenerative resistor	Built-in (0.6 kW to 7 kW) External (11 kW to 22 kW)	Built-in (0.6 kW to 7 kW) External (11 kW to 22 kW)
3	Dynamic brake	Built-in (0.6 kW to 7 kW) External (11 kW to 22 kW)	Built-in (0.6 kW to 7 kW) External (11 kW to 22 kW) Coasting distance may differ. (Note)
4	Control circuit power	1-phase 380 V AC to 480 V AC	1-phase 380 V AC to 480 V AC
5	Main circuit power	3-phase 380 V AC to 480 V AC	3-phase 380 V AC to 480 V AC
6	24 V DC power	External supply required	External supply required
7	Auto Tuning	Real-time auto tuning: 32 steps Advanced gain search	Real-time auto tuning: 40 steps One-touch tuning
8	Control mode	<ul style="list-style-type: none"> • Position control mode (pulse command) • Speed control mode (analog command) • Torque control mode (analog command) 	<ul style="list-style-type: none"> • Position control mode (pulse command) • Speed control mode (analog command) • Torque control mode (analog command)
9	Maximum input pulses	Differential pulse: 1 Mpulse/s Open-collector pulse: 200 kpulses/s Command pulse: Sink	Differential pulse: 4 Mpulses/s Open-collector pulse: 200 kpulses/s Command pulse: Sink
10	The number of DIO points (excluding EM1)	DI: 9 points, DO: 6 points	DI: 9 points, DO: 6 points
11	Encoder pulse output	A/B/Z-phase pulse (differential line driver)	A/B/Z-phase pulse (differential line driver)
12	DIO interface	input/output: sink/source	input/output: sink/source
13	Analog input/output	(Input) 2ch 10-bit torque, 14-bit speed or equivalent (Output) 10-bit or equivalent × 2ch	(Input) 2ch 10-bit torque, 14-bit speed or equivalent (Output) 10-bit or equivalent × 2ch
14	Number of internal speed commands	7 points	7 points
15	Parameter setting method	Setup software (SETUP221E) MR Configurator2 Push button	MR Configurator2 Push button
16	Setup software communication function	USB	USB
17	Servo motor (Encoder resolution)	HF- _P series (18-bit ABS) HA- _P series (18-bit ABS)	HG series (22 -bit ABS)
18	Motor maximum torque	HF-SP 300%	HG-SR 300%
		HF-JP 300%	HG-JR 300%
		HA-LP 250%	HG-JR 300%
19	LED display	7-segment 5-digit	7-segment 5-digit
20	Advanced vibration suppression control	Provided	Provided (Advanced vibration suppression control II)
21	Adaptive filter II	Provided	Provided
22	Notch filter	Provided (2 pcs)	Provided (5 pcs)
23	Tough drive	Unprovided	Provided
24	Drive recorder	Unprovided	Provided
25	Forced stop	EM1 (DB stop)	EM1 (DB stop)/ EM2 (deceleration to a stop)

Note. For the coasting distance, refer to "1.2.3 Dynamic brake: coasting distance" in "Part 8 Common Reference Material".

Part 2: Review on Replacement of MR-J3- _A_ with MR-J4- _A_

(3) 100 V class

Item		MR-J3 series	MR-J4 series
1	Capacity range	0.1 to 0.4 kW/100 V	0.1 to 0.4 kW/100 V
2	Internal regenerative resistor	None (0.1 kW) Built-in (0.2, 0.4 kW)	None (0.1 kW) Built-in (0.2, 0.4 kW)
3	Dynamic brake	Built-in (0.1 to 0.4 kW)	Built-in (0.1 to 0.4 kW) Coasting distance may differ. (Note)
4	Control circuit power	1-phase AC 100 to 120 V	1-phase AC 100 to 120 V
5	Main circuit power	1-phase AC 100 to 120 V (0.1 to 0.4 kW)	1-phase AC 100 to 120 V (0.1 to 0.4 kW)
6	24 V DC power	External supply required	External supply required
7	Auto Tuning	Real-time auto tuning: 32 steps Advanced gain search	Real-time auto tuning: 40 steps One-touch tuning
8	Control mode	<ul style="list-style-type: none"> • Position control mode (pulse command) • Speed control mode (analog command) • Torque control mode (analog command) 	<ul style="list-style-type: none"> • Position control mode (pulse command) • Speed control mode (analog command) • Torque control mode (analog command)
9	Maximum input pulses	Differential pulse: 1 Mpulse/s Open-collector pulse: 200 kpulses/s Command pulse: Sink	Differential pulse: 4 Mpulses/s Open-collector pulse: 200 kpulses/s Command pulse: Sink
10	The number of DIO points (excluding EM1)	DI: 9 points, DO: 6 points	DI: 9 points, DO: 6 points
11	Encoder pulse output	A/B/Z-phase pulse (differential line driver) Z-phase pulse (open collector)	A/B/Z-phase pulse (differential line driver) Z-phase pulse (open collector)
12	DIO interface	input/output: sink/source	input/output: sink/source
13	Analog input/output	(Input) 2ch 10-bit torque, 14-bit speed or equivalent (Output) 10-bit or equivalent × 2ch	(Input) 2ch 10-bit torque, 14-bit speed or equivalent (Output) 10-bit or equivalent × 2ch
14	Number of internal speed commands	7 points	7 points
15	Parameter setting method	Setup software (SETUP221E) MR Configurator2 Push button	MR Configurator2 Push button
16	Setup software communication function	USB	USB
17	Servo motor (Encoder resolution)	HF- _P series (18-bit ABS) HA- _P series (18-bit ABS)	HG series (22 -bit ABS)
18	Motor maximum torque	HF-KP 350% HF-MP 300%	HG-KR 350% HG-MR 300%
19	LED display	7-segment 5-digit	7-segment 5-digit
20	Advanced vibration suppression control	Provided	Provided (Advanced vibration suppression control II)
21	Adaptive filter II	Provided	Provided
22	Notch filter	Provided (2 pcs)	Provided (5 pcs)
23	Tough drive	Unprovided	Provided
24	Drive recorder	Unprovided	Provided
25	Forced stop	EM1 (DB stop)	EM1 (DB stop)/EM2 (deceleration to a stop)

Note. For the coasting distance, refer to "1.2.3 Dynamic brake: coasting distance" in "Part 8 Common Reference Material".

Part 2: Review on Replacement of MR-J3- A_ with MR-J4- A_

3.2 Comparison of Standard Connection Diagrams

(1) Position control mode

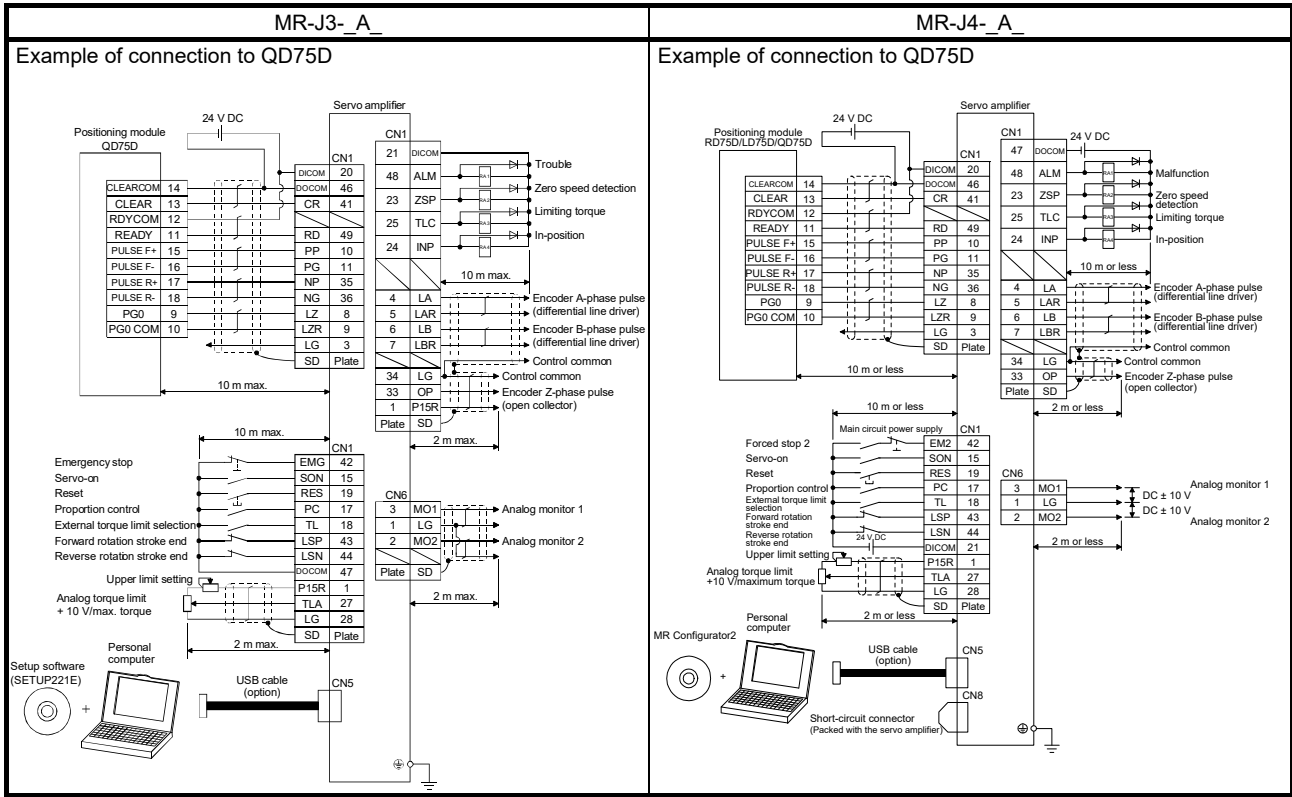

(2) Speed control mode

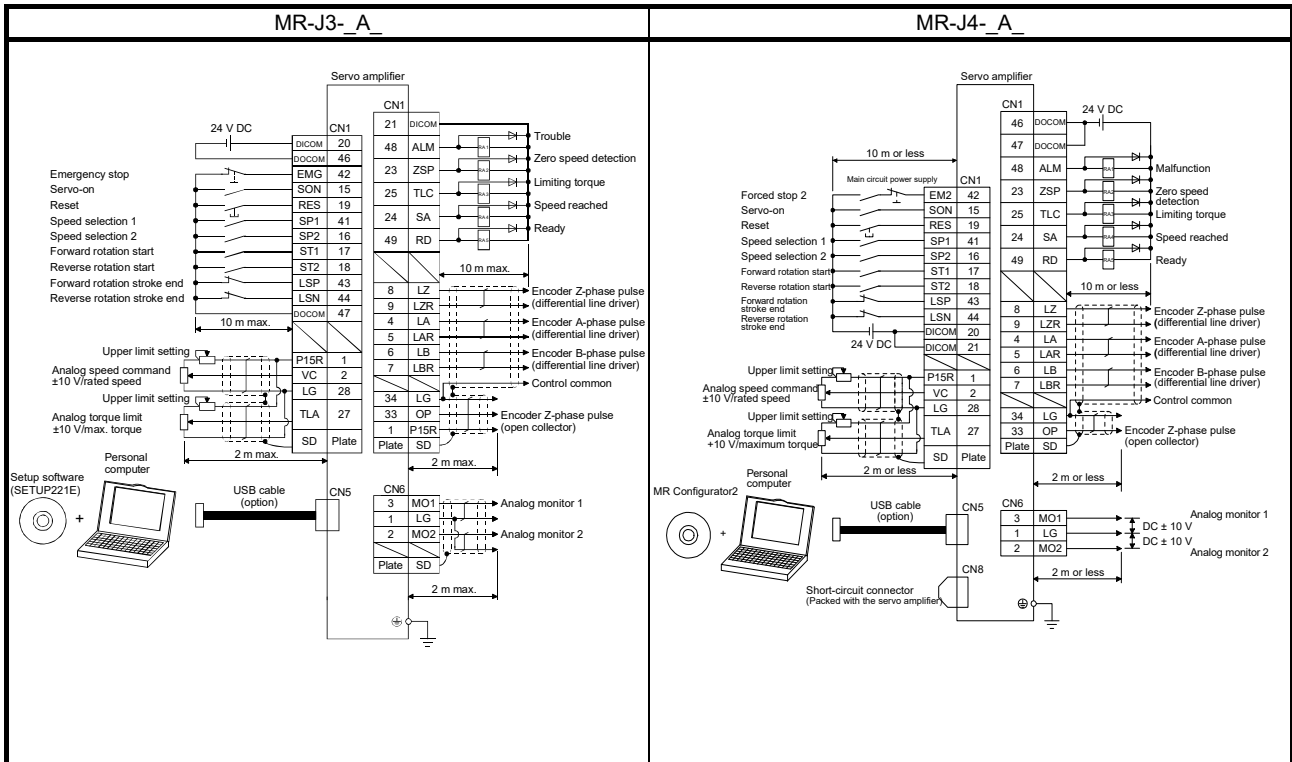

Part 2: Review on Replacement of MR-J3- _A_ with MR-J4- _A_

(3) Torque control mode

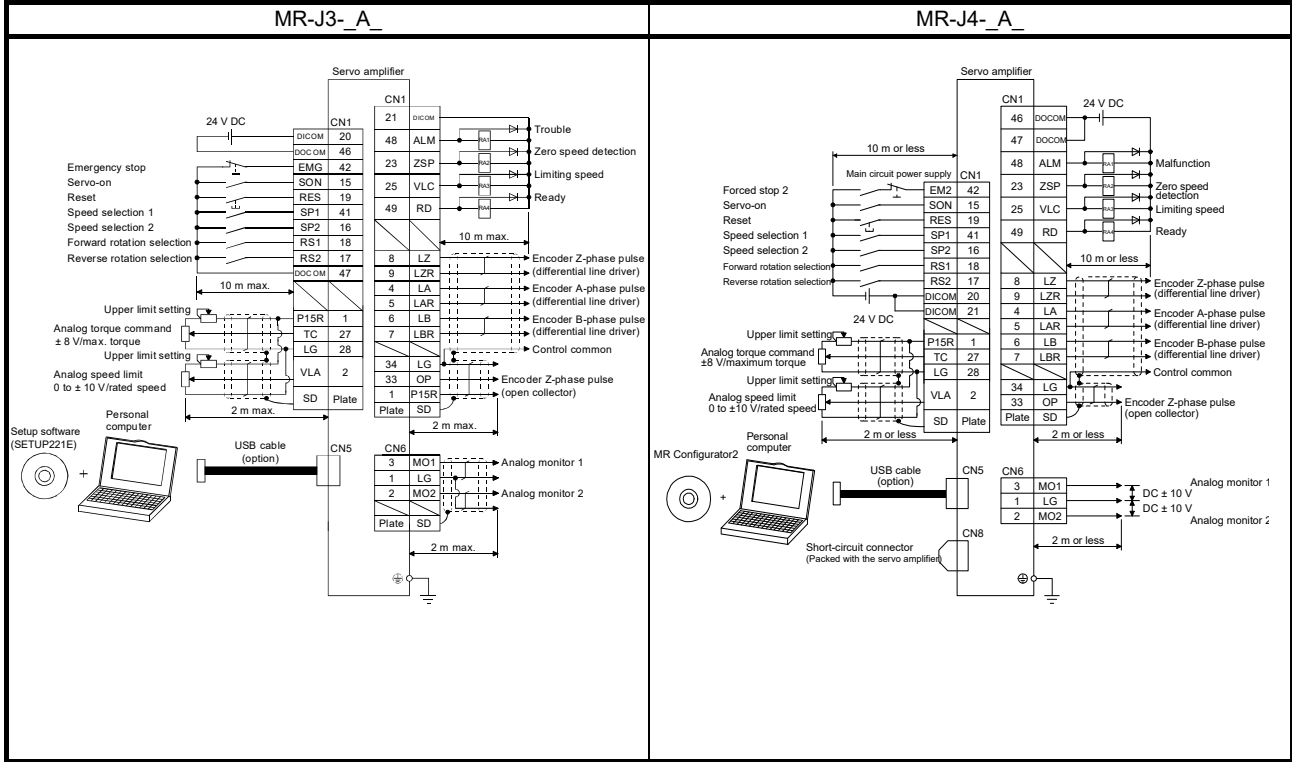

Part 2: Review on Replacement of MR-J3- _A_ with MR-J4- _A_

3.3 List of Corresponding Connectors and Terminal Blocks

(1) Connector comparison table

The following shows examples of connections with the peripheral equipment. For details of signals, refer to each servo amplifier instruction manual.

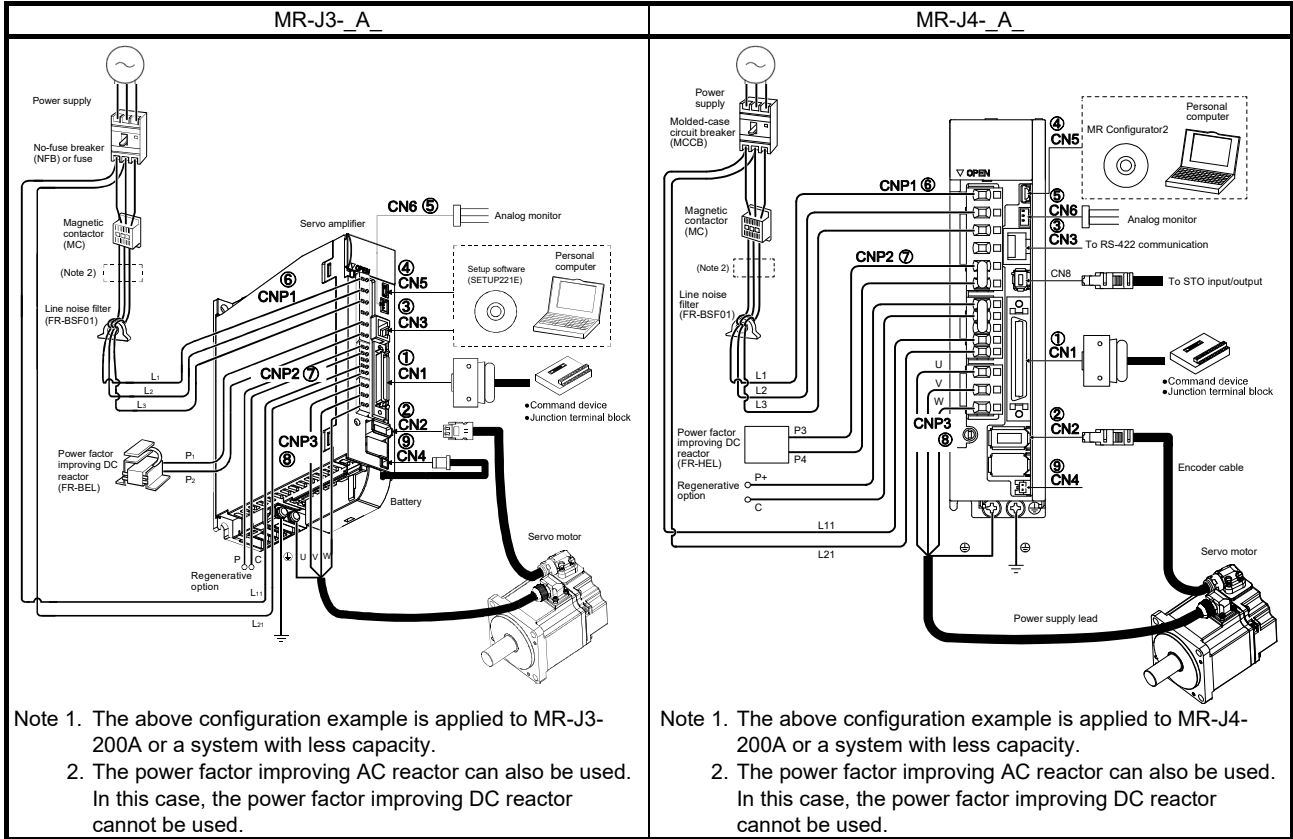

(2) List of connector and terminal block correspondence

MR-J3- _A_			MR-J4- _A_			Precautions
No.	Connector name	Connector No.	No.	Connector name	Connector No.	
①	I/O signal connector	CN1	①	I/O signal connector	CN1	
②	Encoder connector	CN2	②	Encoder connector	CN2	The cable needs to be changed when using 15 kW or more HG-JR 1000 r/min series or 22 kW or more HG-JR 1500 r/min series is used.
③	RS-422 communication connector	CN3	③	RS-422 communication connector	CN3	
④	USB communication connector	CN5	④	USB communication connector	CN5	
⑤	Analog monitor connector	CN6	⑤	Main circuit power connector	CN6	
⑥	Main circuit power supply connector	CNP1	⑥	Main circuit power supply connector	CNP1	Switch to the power connector (enclosed with the servo amplifier).
⑦	Control circuit power supply connector	CNP2	⑦	Control circuit power supply connector	CNP2	
⑧	Servo motor power connector	CNP3	⑧	Servo motor power connector	CNP3	
⑨	Battery connector	CN4	⑨	Battery connector	CN4	Prepare a new battery.

Note. When not using the STO function in MR-J4- _A_ , attach the short-circuit connector supplied with the servo amplifier to CN8 (STO input signal connector).

The configuration of the main circuit terminal block differs depending on the capacity. Refer to "Part 8: Common Reference Material".

Part 2: Review on Replacement of MR-J3- _A_ with MR-J4- _A_

(3) Comparison of signals

Signal abbreviations in parentheses are for MR-J4- _A_ .

(a) CN1

1) Position control mode

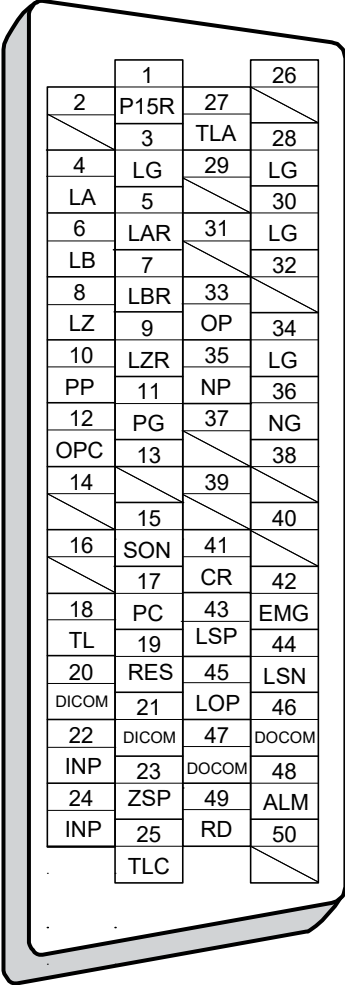
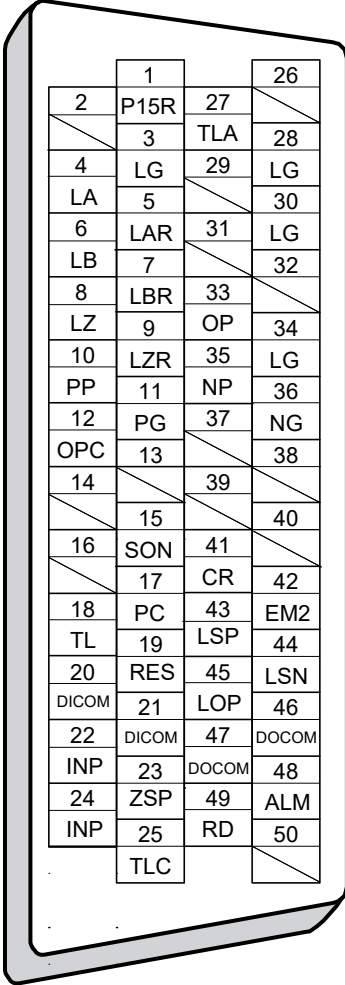
MR-J3- _A_				Signal abbreviation	MR-J4- _A_			
Connector pin assignment		Connector pin No.		Signal abbreviation	Connector pin No.		Connector pin assignment	
<div style="text-align: center;">CN1</div> 					CN1-1	P15R	CN1-1	<div style="text-align: center;">CN1</div> 
				CN1-2		CN1-2		
				CN1-3	LG	CN1-3		
				CN1-4	LA	CN1-4		
				CN1-5	LAR	CN1-5		
				CN1-6	LB	CN1-6		
				CN1-7	LBR	CN1-7		
				CN1-8	LZ	CN1-8		
				CN1-9	LZR	CN1-9		
				CN1-10	PP	CN1-10		
				CN1-11	PG	CN1-11		
				CN1-12	OPC	CN1-12		
				CN1-13		CN1-13		
				CN1-14		CN1-14		
				CN1-15	SON	CN1-15		
				CN1-16		CN1-16		
				CN1-17	PC	CN1-17		
				CN1-18	TL	CN1-18		
				CN1-19	RES	CN1-19		
				CN1-20	DICOM	CN1-20		
				CN1-21	DICOM	CN1-21		
				CN1-22	INP	CN1-22		
				CN1-23	ZSP	CN1-23		
				CN1-24	INP	CN1-24		
				CN1-25	TLC	CN1-25		
				CN1-26		CN1-26		
				CN1-27	TLA	CN1-27		
				CN1-28	LG	CN1-28		
				CN1-29		CN1-29		
				CN1-30	LG	CN1-30		
				CN1-31		CN1-31		
				CN1-32		CN1-32		
				CN1-33	OP	CN1-33		
				CN1-34	LG	CN1-34		
				CN1-35	NP	CN1-35		
				CN1-36	NG	CN1-36		
				CN1-37		CN1-37		
				CN1-38		CN1-38		
				CN1-39		CN1-39		
				CN1-40		CN1-40		
				CN1-41	CR	CN1-41		
				CN1-42	EMG (EM2)	CN1-42		
				CN1-43	LSP	CN1-43		
				CN1-44	LSN	CN1-44		
				CN1-45	LOP	CN1-45		
				CN1-46	DOCOM	CN1-46		
				CN1-47	DOCOM	CN1-47		
				CN1-48	ALM	CN1-48		
				CN1-49	RD	CN1-49		
				CN1-50		CN1-50		

Part 2: Review on Replacement of MR-J3-_A_ with MR-J4-_A_

2) Speed control mode

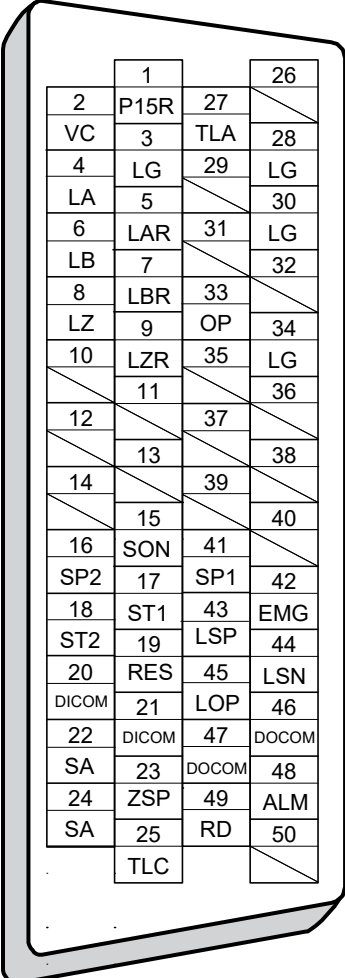
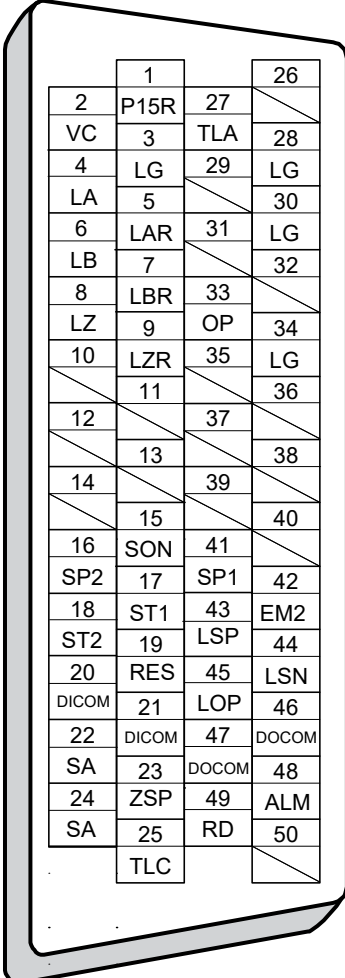
MR-J3-_A_				Signal abbreviation	MR-J4-_A_																																																																																																																																																																																																																					
Connector pin assignment		Connector pin No.			Connector pin No.		Connector pin assignment																																																																																																																																																																																																																			
<p style="text-align: center;">CN1</p>  <table border="1" style="margin-left: auto; margin-right: auto;"> <tr><td>1</td><td></td><td>26</td><td></td></tr> <tr><td>2</td><td>P15R</td><td>27</td><td></td></tr> <tr><td>VC</td><td>3</td><td>TLA</td><td>28</td></tr> <tr><td>4</td><td>LG</td><td>29</td><td>LG</td></tr> <tr><td>LA</td><td>5</td><td></td><td>30</td></tr> <tr><td>6</td><td>LAR</td><td>31</td><td>LG</td></tr> <tr><td>LB</td><td>7</td><td></td><td>32</td></tr> <tr><td>8</td><td>LBR</td><td>33</td><td></td></tr> <tr><td>LZ</td><td>9</td><td>OP</td><td>34</td></tr> <tr><td>10</td><td>LZR</td><td>35</td><td>LG</td></tr> <tr><td></td><td>11</td><td></td><td>36</td></tr> <tr><td>12</td><td></td><td>37</td><td></td></tr> <tr><td></td><td>13</td><td></td><td>38</td></tr> <tr><td>14</td><td></td><td>39</td><td></td></tr> <tr><td></td><td>15</td><td></td><td>40</td></tr> <tr><td>16</td><td>SON</td><td>41</td><td></td></tr> <tr><td>SP2</td><td>17</td><td>SP1</td><td>42</td></tr> <tr><td>18</td><td>ST1</td><td>43</td><td>EMG</td></tr> <tr><td>ST2</td><td>19</td><td>LSP</td><td>44</td></tr> <tr><td>20</td><td>RES</td><td>45</td><td>LSN</td></tr> <tr><td>DICOM</td><td>21</td><td>LOP</td><td>46</td></tr> <tr><td>22</td><td>DICOM</td><td>47</td><td>DOCOM</td></tr> <tr><td>SA</td><td>23</td><td>DOCOM</td><td>48</td></tr> <tr><td>24</td><td>ZSP</td><td>49</td><td>ALM</td></tr> <tr><td>SA</td><td>25</td><td>RD</td><td>50</td></tr> <tr><td></td><td>TLC</td><td></td><td></td></tr> </table>				1		26		2	P15R	27		VC	3	TLA	28	4	LG	29	LG	LA	5		30	6	LAR	31	LG	LB	7		32	8	LBR	33		LZ	9	OP	34	10	LZR	35	LG		11		36	12		37			13		38	14		39			15		40	16	SON	41		SP2	17	SP1	42	18	ST1	43	EMG	ST2	19	LSP	44	20	RES	45	LSN	DICOM	21	LOP	46	22	DICOM	47	DOCOM	SA	23	DOCOM	48	24	ZSP	49	ALM	SA	25	RD	50		TLC			CN1-1	P15R	CN1-1	<p style="text-align: center;">CN1</p>  <table border="1" style="margin-left: auto; margin-right: auto;"> <tr><td>1</td><td></td><td>26</td><td></td></tr> <tr><td>2</td><td>P15R</td><td>27</td><td></td></tr> <tr><td>VC</td><td>3</td><td>TLA</td><td>28</td></tr> <tr><td>4</td><td>LG</td><td>29</td><td>LG</td></tr> <tr><td>LA</td><td>5</td><td></td><td>30</td></tr> <tr><td>6</td><td>LAR</td><td>31</td><td>LG</td></tr> <tr><td>LB</td><td>7</td><td></td><td>32</td></tr> <tr><td>8</td><td>LBR</td><td>33</td><td></td></tr> <tr><td>LZ</td><td>9</td><td>OP</td><td>34</td></tr> <tr><td>10</td><td>LZR</td><td>35</td><td>LG</td></tr> <tr><td></td><td>11</td><td></td><td>36</td></tr> <tr><td>12</td><td></td><td>37</td><td></td></tr> <tr><td></td><td>13</td><td></td><td>38</td></tr> <tr><td>14</td><td></td><td>39</td><td></td></tr> <tr><td></td><td>15</td><td></td><td>40</td></tr> <tr><td>16</td><td>SON</td><td>41</td><td></td></tr> <tr><td>SP2</td><td>17</td><td>SP1</td><td>42</td></tr> <tr><td>18</td><td>ST1</td><td>43</td><td>EM2</td></tr> <tr><td>ST2</td><td>19</td><td>LSP</td><td>44</td></tr> <tr><td>20</td><td>RES</td><td>45</td><td>LSN</td></tr> <tr><td>DICOM</td><td>21</td><td>LOP</td><td>46</td></tr> <tr><td>22</td><td>DICOM</td><td>47</td><td>DOCOM</td></tr> <tr><td>SA</td><td>23</td><td>DOCOM</td><td>48</td></tr> <tr><td>24</td><td>ZSP</td><td>49</td><td>ALM</td></tr> <tr><td>SA</td><td>25</td><td>RD</td><td>50</td></tr> <tr><td></td><td>TLC</td><td></td><td></td></tr> </table>				1		26		2	P15R	27		VC	3	TLA	28	4	LG	29	LG	LA	5		30	6	LAR	31	LG	LB	7		32	8	LBR	33		LZ	9	OP	34	10	LZR	35	LG		11		36	12		37			13		38	14		39			15		40	16	SON	41		SP2	17	SP1	42	18	ST1	43	EM2	ST2	19	LSP	44	20	RES	45	LSN	DICOM	21	LOP	46	22	DICOM	47	DOCOM	SA	23	DOCOM	48	24	ZSP	49	ALM	SA	25	RD	50		TLC		
				1		26																																																																																																																																																																																																																				
				2	P15R	27																																																																																																																																																																																																																				
				VC	3	TLA	28																																																																																																																																																																																																																			
				4	LG	29	LG																																																																																																																																																																																																																			
				LA	5		30																																																																																																																																																																																																																			
				6	LAR	31	LG																																																																																																																																																																																																																			
				LB	7		32																																																																																																																																																																																																																			
				8	LBR	33																																																																																																																																																																																																																				
				LZ	9	OP	34																																																																																																																																																																																																																			
				10	LZR	35	LG																																																																																																																																																																																																																			
					11		36																																																																																																																																																																																																																			
				12		37																																																																																																																																																																																																																				
					13		38																																																																																																																																																																																																																			
				14		39																																																																																																																																																																																																																				
					15		40																																																																																																																																																																																																																			
				16	SON	41																																																																																																																																																																																																																				
				SP2	17	SP1	42																																																																																																																																																																																																																			
				18	ST1	43	EMG																																																																																																																																																																																																																			
				ST2	19	LSP	44																																																																																																																																																																																																																			
				20	RES	45	LSN																																																																																																																																																																																																																			
				DICOM	21	LOP	46																																																																																																																																																																																																																			
				22	DICOM	47	DOCOM																																																																																																																																																																																																																			
				SA	23	DOCOM	48																																																																																																																																																																																																																			
				24	ZSP	49	ALM																																																																																																																																																																																																																			
				SA	25	RD	50																																																																																																																																																																																																																			
					TLC																																																																																																																																																																																																																					
				1		26																																																																																																																																																																																																																				
				2	P15R	27																																																																																																																																																																																																																				
				VC	3	TLA	28																																																																																																																																																																																																																			
				4	LG	29	LG																																																																																																																																																																																																																			
				LA	5		30																																																																																																																																																																																																																			
				6	LAR	31	LG																																																																																																																																																																																																																			
				LB	7		32																																																																																																																																																																																																																			
				8	LBR	33																																																																																																																																																																																																																				
				LZ	9	OP	34																																																																																																																																																																																																																			
				10	LZR	35	LG																																																																																																																																																																																																																			
					11		36																																																																																																																																																																																																																			
				12		37																																																																																																																																																																																																																				
					13		38																																																																																																																																																																																																																			
				14		39																																																																																																																																																																																																																				
					15		40																																																																																																																																																																																																																			
				16	SON	41																																																																																																																																																																																																																				
				SP2	17	SP1	42																																																																																																																																																																																																																			
				18	ST1	43	EM2																																																																																																																																																																																																																			
				ST2	19	LSP	44																																																																																																																																																																																																																			
				20	RES	45	LSN																																																																																																																																																																																																																			
				DICOM	21	LOP	46																																																																																																																																																																																																																			
				22	DICOM	47	DOCOM																																																																																																																																																																																																																			
				SA	23	DOCOM	48																																																																																																																																																																																																																			
24	ZSP	49	ALM																																																																																																																																																																																																																							
SA	25	RD	50																																																																																																																																																																																																																							
	TLC																																																																																																																																																																																																																									
CN1-2	VC	CN1-2																																																																																																																																																																																																																								
CN1-3	LG	CN1-3																																																																																																																																																																																																																								
CN1-4	LA	CN1-4																																																																																																																																																																																																																								
CN1-5	LAR	CN1-5																																																																																																																																																																																																																								
CN1-6	LB	CN1-6																																																																																																																																																																																																																								
CN1-7	LBR	CN1-7																																																																																																																																																																																																																								
CN1-8	LZ	CN1-8																																																																																																																																																																																																																								
CN1-9	LZR	CN1-9																																																																																																																																																																																																																								
CN1-10		CN1-10																																																																																																																																																																																																																								
CN1-11		CN1-11																																																																																																																																																																																																																								
CN1-12		CN1-12																																																																																																																																																																																																																								
CN1-13		CN1-13																																																																																																																																																																																																																								
CN1-14		CN1-14																																																																																																																																																																																																																								
CN1-15	SON	CN1-15																																																																																																																																																																																																																								
CN1-16	SP2	CN1-16																																																																																																																																																																																																																								
CN1-17	ST1	CN1-17																																																																																																																																																																																																																								
CN1-18	ST2	CN1-18																																																																																																																																																																																																																								
CN1-19	RES	CN1-19																																																																																																																																																																																																																								
CN1-20	DICOM	CN1-20																																																																																																																																																																																																																								
CN1-21	DICOM	CN1-21																																																																																																																																																																																																																								
CN1-22	SA	CN1-22																																																																																																																																																																																																																								
CN1-23	ZSP	CN1-23																																																																																																																																																																																																																								
CN1-24	SA	CN1-24																																																																																																																																																																																																																								
CN1-25	TLC	CN1-25																																																																																																																																																																																																																								
CN1-26		CN1-26																																																																																																																																																																																																																								
CN1-27	TLA	CN1-27																																																																																																																																																																																																																								
CN1-28	LG	CN1-28																																																																																																																																																																																																																								
CN1-29		CN1-29																																																																																																																																																																																																																								
CN1-30	LG	CN1-30																																																																																																																																																																																																																								
CN1-31		CN1-31																																																																																																																																																																																																																								
CN1-32		CN1-32																																																																																																																																																																																																																								
CN1-33	OP	CN1-33																																																																																																																																																																																																																								
CN1-34	LG	CN1-34																																																																																																																																																																																																																								
CN1-35		CN1-35																																																																																																																																																																																																																								
CN1-36		CN1-36																																																																																																																																																																																																																								
CN1-37		CN1-37																																																																																																																																																																																																																								
CN1-38		CN1-38																																																																																																																																																																																																																								
CN1-39		CN1-39																																																																																																																																																																																																																								
CN1-40		CN1-40																																																																																																																																																																																																																								
CN1-41	SP1	CN1-41																																																																																																																																																																																																																								
CN1-42	EMG (EM2)	CN1-42																																																																																																																																																																																																																								
CN1-43	LSP	CN1-43																																																																																																																																																																																																																								
CN1-44	LSN	CN1-44																																																																																																																																																																																																																								
CN1-45	LOP	CN1-45																																																																																																																																																																																																																								
CN1-46	DOCOM	CN1-46																																																																																																																																																																																																																								
CN1-47	DOCOM	CN1-47																																																																																																																																																																																																																								
CN1-48	ALM	CN1-48																																																																																																																																																																																																																								
CN1-49	RD	CN1-49																																																																																																																																																																																																																								
CN1-50		CN1-50																																																																																																																																																																																																																								

Part 2: Review on Replacement of MR-J3- _A_ with MR-J4- _A_

3) Torque control mode



MR-J3- _A_				Signal	MR-J4- _A_			
Connector pin assignment		Connector pin No.		abbreviation	Connector pin No.		Connector pin assignment	
			CN1-1	P15R		CN1-1		
			CN1-2	VLA		CN1-2		
			CN1-3	LG		CN1-3		
			CN1-4	LA		CN1-4		
			CN1-5	LAR		CN1-5		
			CN1-6	LB		CN1-6		
			CN1-7	LBR		CN1-7		
			CN1-8	LZ		CN1-8		
			CN1-9	LZR		CN1-9		
			CN1-10			CN1-10		
			CN1-11			CN1-11		
			CN1-12			CN1-12		
			CN1-13			CN1-13		
			CN1-14			CN1-14		
			CN1-15	SON		CN1-15		
			CN1-16	SP2		CN1-16		
			CN1-17	RS2		CN1-17		
			CN1-18	RS1		CN1-18		
			CN1-19	RES		CN1-19		
			CN1-20	DICOM		CN1-20		
			CN1-21	DICOM		CN1-21		
			CN1-22			CN1-22		
			CN1-23	ZSP		CN1-23		
			CN1-24			CN1-24		
			CN1-25	VLC		CN1-25		
			CN1-26			CN1-26		
			CN1-27	TC		CN1-27		
			CN1-28	LG		CN1-28		
			CN1-29			CN1-29		
			CN1-30	LG		CN1-30		
			CN1-31			CN1-31		
			CN1-32			CN1-32		
			CN1-33	OP		CN1-33		
			CN1-34	LG		CN1-34		
			CN1-35			CN1-35		
			CN1-36			CN1-36		
			CN1-37			CN1-37		
			CN1-38			CN1-38		
			CN1-39			CN1-39		
			CN1-40			CN1-40		
			CN1-41	SP1		CN1-41		
			CN1-42	EMG (EM2)		CN1-42		
			CN1-43			CN1-43		
			CN1-44			CN1-44		
			CN1-45	LOP		CN1-45		
			CN1-46	DOCOM		CN1-46		
			CN1-47	DOCOM		CN1-47		
			CN1-48	ALM		CN1-48		
			CN1-49	RD		CN1-49		
			CN1-50			CN1-50		

CN1

CN1

Part 2: Review on Replacement of MR-J3- _A_ with MR-J4- _A_

(b) CN6

MR-J3- _A_		Signal abbreviation	MR-J4- _A_	
Connector pin assignment	Connector pin No.		Connector pin No.	Connector pin assignment
	CN6-1	LG	CN6-1	
	CN6-2	MO1	CN6-2	
	CN6-3	MO2	CN6-3	

(c) CN3

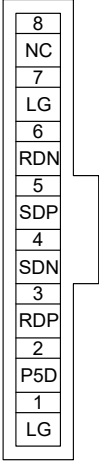
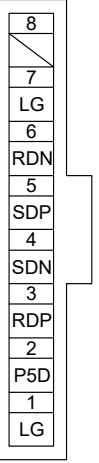
MR-J3- _A_		Signal abbreviation	MR-J4- _A_	
Connector pin assignment	Connector pin No.		Connector pin No.	Connector pin assignment
	CN3-1	LG	CN3-1	
	CN3-2	P5D	CN3-2	
	CN3-3	RDP	CN3-3	
	CN3-4	SDN	CN3-4	
	CN3-5	SDP	CN3-5	
	CN3-6	RDN	CN3-6	
	CN3-7	LG	CN3-7	
	CN3-8	NC (-)	CN3-8	

Part 2: Review on Replacement of MR-J3- _A_ with MR-J4- _A_

3.4 Comparison of Peripheral Equipment

POINT	
●	Refer to "Part 10: Replacement of Optional Peripheral Equipment".

Part 2: Review on Replacement of MR-J3- _A_ with MR-J4- _A_

3.5 Comparison of Parameters



CAUTION

- Never perform extreme adjustments and changes to the parameters, otherwise the operation may become unstable.
- If fixed values are written in the digits of a parameter, do not change these values.
- Do not change parameters for manufacturer setting.
- Do not enter any setting value other than those specified for each parameter.

POINT

- For the parameter converter function, refer to "Part 8: Common Reference Material".
- To enable a parameter whose abbreviation is preceded by *, turn the power OFF and then ON after setting the parameter.
- For details about parameter settings for replacement, refer to the "MR-J4- _A_ (-RJ)/MR-J4-03A6(-RJ) Servo Amplifier Instruction Manual".
- With MR-J4- _A_ (-RJ), the deceleration to a stop function is enabled by factory settings. To disable the deceleration to a stop function, set [Pr. PA04] to "0 _ _ _".

3.5.1 Setting requisite parameters upon replacement

The parameters shown in this section are a minimum number of parameters that need to be set for simultaneous replacement. Depending on the settings of the currently used servo amplifier, parameters other than these may need to be set.

(1) Parameters common to position control mode, speed control mode, and torque control mode

MR-J3- _A_		MR-J4- _A_		Precautions
No.	Name	No.	Name	
PA02	Regenerative option	PA02	Regenerative option	The setting value must be changed to use the regenerative option added for MR-J4- _A_.
PA04	CN1-23 pin function selection			No corresponding parameter (Can substitute with PD23 to PD26, PD28.)
PA05	Number of command input pulses per revolution	PA05	Number of command input pulses per revolution	The setting value must be changed according to the encoder resolution. The setting value must be changed according to PA21 (Electronic gear selection). When MR-J3- _A_ : PA05 = 0 →MR-J4- _A_ : PA21 = 2 _ _ _ (Set the values of PA06 and PA07 for J3.) When MR-J3- _A_ : PA05 = other than 0 →MR-J4- _A_ : PA21 = 1 _ _ _
PA06	Electronic gear numerator	PA06	Electronic gear numerator	
PA07	Electronic gear denominator	PA07	Electronic gear denominator	
PA09	Auto tuning response	PA09	Auto tuning response	The setting value must be changed based on machine resonance frequency.
PB06	Load to motor inertia ratio	PB06	Load to motor inertia ratio	The unit system is different. (0.1 times → 0.01 times) Check the setting value.
PB07	Model loop gain	PB07	Model loop gain	The unit system is different. (rad/s → 0.1 rad/s)
PB08	Position loop gain	PB08	Position loop gain	The unit system is different. (rad/s → 0.1 rad/s)
PB29	Load to motor inertia ratio after gain switching	PB29	Load to motor inertia ratio after gain switching	The unit system is different. (0.1 times → 0.01 times) Check the setting value.
PB30	Position loop gain after gain switching	PB30	Position loop gain after gain switching	The unit system is different. (rad/s → 0.1 rad/s)

Part 2: Review on Replacement of MR-J3- _A_ with MR-J4- _A_

MR-J3- _A_		MR-J4- _A_		Precautions
No.	Name	No.	Name	
PC14	Analog monitor 1 output	PC14	Analog monitor 1 output	When the command pulse frequency is selected (± 10 V/1 Mpulses/s \rightarrow ± 10 V/4 Mpulses/s)
PC15	Analog monitor 2 output	PC15	Analog monitor 2 output	When the command pulse frequency is selected (± 10 V/1 Mpulses/s \rightarrow ± 10 V/4 Mpulses/s)
PC22	Restart after instantaneous power failure selection Encoder cable communication method selection	PC22	Encoder cable communication method selection	"Restart after instantaneous power failure selection" is not supported.
PC37	Analog speed command offset/ Analog speed limit offset	PC37	Analog speed command offset/ Analog speed limit offset	Depends on hardware. The setting values must be changed.
PC38	Analog torque command offset/ Analog torque limit offset	PC38	Analog torque command offset/ Analog torque limit offset	Depends on hardware. The setting values must be changed.
PC39	Analog monitor 1 offset	PC39	Analog monitor 1 offset	Depends on hardware. The setting values must be changed.
PC40	Analog monitor 2 offset	PC40	Analog monitor 2 offset	Depends on hardware. The setting values must be changed.
PD03	Input signal device selection 1 (CN1-15)	PD03	Input device selection 1L	
		PD04	Input device selection 1H	
PD04	Input signal device selection 2 (CN1-16)	PD05	Input device selection 2L	
		PD06	Input device selection 2H	
PD05	Input signal device selection 3 (CN1-17)	PD07	Input device selection 3L	
		PD08	Input device selection 3H	
PD06	Input signal device selection 4 (CN1-18)	PD09	Input device selection 4L	
		PD10	Input device selection 4H	
PD07	Input signal device selection 5 (CN1-19)	PD11	Input device selection 5L	
		PD12	Input device selection 5H	
PD08	Input signal device selection 6 (CN1-41)	PD13	Input device selection 6L	
		PD14	Input device selection 6H	
PD10	Input signal device selection 8 (CN1-43)	PD17	Input device selection 8L	
		PD18	Input device selection 8H	
PD11	Input signal device selection 9 (CN1-44)	PD19	Input device selection 9L	
		PD20	Input device selection 9H	
PD12	Input signal device selection 10 (CN1-45)	PD21	Input device selection 10L	
		PD22	Input device selection 10H	
PD13	Output signal device selection 1 (CN1-22)	PD23	Output device selection 1	The setting value 06 (DB) is added.
PD14	Output signal device selection 2 (CN1-23)	PD24	Output device selection 2	The setting value 06 (DB) is added.
PD15	Output signal device selection 3 (CN1-24)	PD25	Output device selection 3	The setting value 06 (DB) is added.
PD16	Output signal device selection 4 (CN1-25)	PD26	Output device selection 4	The setting value 06 (DB) is added.
PD18	Output signal device selection 6 (CN1-49)	PD28	Output device selection 6	The setting value 06 (DB) is added.
PD19	Input filter setting	PD29	Input filter setting	The filter setting value differs.
PD20	Function selection D-1	PD30	Function selection D-1	
PD22	Function selection D-3	PD32	Function selection D-3	
PD24	Function selection D-5	PD34	Function selection D-5	

Part 2: Review on Replacement of MR-J3- _A_ with MR-J4- _A_

3.5.2 Parameter comparison list

MR-J3- _A_ parameters					MR-J4- _A_ parameters				
No.	Abbreviation	Parameter name	Initial value	Customer setting value	No.	Abbreviation	Parameter name	Initial value	Customer setting value
PA01	*STY	Control mode	0000h		PA01	*STY	Operation mode	1000h	
PA02	*REG	Regenerative option	0000h		PA02	*REG	Regenerative option	0000h	
PA03	*ABS	Absolute position detection system	0000h		PA03	*ABS	Absolute position detection system	0000h	
PA04	*AOP1	Function selection A-1	0000h		PD23	*DO1	Output device selection 1	0004h	
					PD24	*DO2	Output device selection 2	000Ch	
					PD25	*DO3	Output device selection 3	0004h	
					PD26	*DO4	Output device selection 4	0007h	
					PD28	*DO6	Output device selection 6	0002h	
PA05	*FBP	Number of command input pulses per revolution	0		PA05	*FBP	Number of command input pulses per revolution	10000	
PA06	CMX	Electronic gear numerator (Command pulse multiplying factor numerator)	1		PA06	CMX	Electronic gear numerator (command pulse multiplication numerator)	1	
PA07	CDV	Electronic gear denominator (Command pulse multiplying factor denominator)	1		PA07	CDV	Electronic gear denominator (command pulse multiplication denominator)	1	
PA08	ATU	Auto tuning mode	0001h		PA08	ATU	Auto tuning mode	0001h	
PA09	RSP	Auto tuning response	12		PA09	RSP	Auto tuning response	16	
PA10	INP	In-position range	100		PA10	INP	In-position range	100	
PA11	TLP	Forward rotation torque limit	100.0		PA11	TLP	Forward rotation torque limit	100.0	
PA12	TLN	Reverse rotation torque limit	100.0		PA12	TLN	Reverse rotation torque limit	100.0	
PA13	*PLSS	Command pulse input form	0000h		PA13	*PLSS	Command pulse input form	0100h	
PA14	*POL	Rotation direction selection	0		PA14	*POL	Rotation direction selection	0	
PA15	*ENR	Encoder output pulses	4000		PA15	*ENR	Encoder output pulses	4000	
PA16		For manufacturer setting	0000h		PA16	*ENR2	Encoder output pulses 2	1	
PA17			0000h		PA17	*MSR	Servo motor series setting	0000h	
PA18			0000h		PA18	*MTY	Servo motor type setting	0000h	
PA19	*BLK	Parameter write inhibit	000Bh		PA19	*BLK	Parameter writing inhibit	00AAh	
PB01	FILT	Adaptive tuning mode (Adaptive filter II)	0000h		PB01	FILT	Adaptive tuning mode (adaptive filter II)	0000h	
PB02	VRFT	Vibration suppression control tuning mode (Advanced vibration suppression control)	0000h		PB02	VRFT	Vibration suppression control tuning mode (advanced vibration suppression control II)	0000h	
PB03	PST	Position command acceleration/deceleration time constant (Position smoothing)	0		PB03	PST	Position command acceleration/deceleration time constant (position smoothing)	0	
PB04	FFC	Feed forward gain	0		PB04	FFC	Feed forward gain	0	
PB05		For manufacturer setting	500		PB05		For manufacturer setting	500	
PB06	GD2	Ratio of load inertia moment to servo motor inertia moment	7.0		PB06	GD2	Load to motor inertia ratio	7.00	
PB07	PG1	Model loop gain	24		PB07	PG1	Model loop gain (Note)	15.0	
PB08	PG2	Position loop gain	37		PB08	PG2	Position loop gain (Note)	37.0	
PB09	VG2	Speed loop gain	823		PB09	VG2	Speed loop gain (Note)	823	
PB10	VIC	Speed integral compensation	33.7		PB10	VIC	Speed integral compensation (Note)	33.7	
PB11	VDC	Speed differential compensation	980		PB11	VDC	Speed differential compensation (Note)	980	
PB12		For manufacturer setting	0		PB12	OVA	Overshoot amount compensation	0	
PB13	NH1	Machine resonance suppression filter 1	4500		PB13	NH1	Machine resonance suppression filter 1	4500	
PB14	NHQ1	Notch shape selection 1	0000h		PB14	NHQ1	Notch shape selection 1	0000h	
PB15	NH2	Machine resonance suppression filter 2	4500		PB15	NH2	Machine resonance suppression filter 2	4500	
PB16	NHQ2	Notch shape selection 2	0000h		PB16	NHQ2	Notch shape selection 2	0000h	

Note. Parameters related to gain adjustment are different from those for the MR-J3- _A_ servo amplifier. For gain adjustment, refer to "MR-J4- _A_ (-RJ)/MR-J4-03A6(-RJ) Servo Amplifier Instruction Manual".

Part 2: Review on Replacement of MR-J3- _A_ with MR-J4- _A_

MR-J3- _A_ parameters					MR-J4- _A_ parameters				
No.	Abbreviation	Parameter name	Initial value	Customer setting value	No.	Abbreviation	Parameter name	Initial value	Customer setting value
PB17		Automatic setting parameter			PB17	NHF	Shaft resonance suppression filter	0000h	
PB18	LPF	Low-pass filter setting	3141		PB18	LPF	Low-pass filter setting	3141	
PB19	VRF1	Vibration suppression control vibration frequency setting	100.0		PB19	VRF11	Vibration suppression control 1 - Vibration frequency	100.0	
PB20	VRF2	Vibration suppression control resonance frequency setting	100.0		PB20	VRF12	Vibration suppression control 1 - Resonance frequency	100.0	
PB21		For manufacturer setting	0.00		PB21	VRF13	Vibration suppression control 1 - Vibration frequency damping	0.00	
PB22			0.00		PB22	VRF14	Vibration suppression control 1 - Resonance frequency damping	0.00	
PB23	VFBF	Low-pass filter selection	0000h		PB23	VFBF	Low-pass filter selection	0000h	
PB24	*MVS	Slight vibration suppression control selection	0000h		PB24	*MVS	Slight vibration suppression control	0000h	
PB25	*BOP1	Function selection B-1	0000h		PB25	*BOP1	Function selection B-1	0000h	
PB26	*CDP	Gain changing selection	0000h		PB26	*CDP	Gain switching function	0000h	
PB27	CDL	Gain changing condition	10		PB27	CDL	Gain switching condition	10	
PB28	CDT	Gain changing time constant	1		PB28	CDT	Gain switching time constant	1	
PB29	GD2B	Gain changing ratio of load inertia moment to servo motor inertia moment	7.0		PB29	GD2B	Load to motor inertia ratio after gain switching	7.00	
PB30	PG2B	Gain changing position loop gain	37		PB30	PG2B	Position loop gain after gain switching	0.0	
PB31	VG2B	Gain changing speed loop gain	823		PB31	VG2B	Speed loop gain after gain switching	0	
PB32	VICB	Gain changing speed integral compensation	33.7		PB32	VICB	Speed integral compensation after gain switching	0.0	
PB33	VRF1B	Gain changing vibration suppression control vibration frequency setting	100.0		PB33	VRF1B	Vibration suppression control 1 - Vibration frequency after gain switching	0.0	
PB34	VRF2B	Gain changing vibration suppression control resonance frequency setting	100.0		PB34	VRF2B	Vibration suppression control 1 - Resonance frequency after gain switching	0.0	
PB35		For manufacturer setting	0.00		PB35	VRF3B	Vibration suppression control 1 - Vibration frequency damping after gain switching	0.00	
PB36			0.00		PB36	VRF4B	Vibration suppression control 1 - Resonance frequency damping after gain switching	0.00	
PB37			100		For manufacturer setting		1600		
PB38			0.0				0.00		
PB39			0.0				0.00		
PB40			0.0				0.00		
PB41			1125				0000h		
PB42			1125				0000h		
PB43			0004h				0000h		
PB44			0000h				0.00		
PB45		0000h		PB45		CNHF	Command notch filter	0000h	
PC01	STA	Acceleration time constant	0			PC01	STA	Acceleration time constant	0
PC02	STB	Deceleration time constant	0		PC02	STB	Deceleration time constant	0	
PC03	STC	S-pattern acceleration/ deceleration time constant	0		PC03	STC	S-pattern acceleration/ deceleration time constant	0	
PC04	TQC	Torque command time constant	0		PC04	TQC	Torque command time constant	0	
PC05	SC1	Internal speed command 1	100		PC05	SC1	Internal speed command 1	100	
		Internal speed limit 1					Internal speed limit 1		
PC06	SC2	Internal speed command 2	500		PC06	SC2	Internal speed command 2	500	
		Internal speed limit 2					Internal speed limit 2		
PC07	SC3	Internal speed command 3	1000		PC07	SC3	Internal speed command 3	1000	
		Internal speed limit 3					Internal speed limit 3		
PC08	SC4	Internal speed command 4	200		PC08	SC4	Internal speed command 4	200	
		Internal speed limit 4					Internal speed limit 4		
PC09	SC5	Internal speed command 5	300		PC09	SC5	Internal speed command 5	300	
		Internal speed limit 5					Internal speed limit 5		

Part 2: Review on Replacement of MR-J3- _A_ with MR-J4- _A_

MR-J3- _A_ parameters					MR-J4- _A_ parameters					
No.	Abbreviation	Parameter name	Initial value	Customer setting value	No.	Abbreviation	Parameter name	Initial value	Customer setting value	
PC10	SC6	Internal speed command 6	500		PC10	SC6	Internal speed command 6	500		
		Internal speed limit 6					Internal speed limit 6			
PC11	SC7	Internal speed command 7	800		PC11	SC7	Internal speed command 7	800		
		Internal speed limit 7					Internal speed limit 7			
PC12	VCM	Analog speed command maximum speed	0		PC12	VCM	Analog speed command - Maximum speed	0		
		Analog speed limit maximum speed					Analog speed limit - Maximum speed			
PC13	TLC	Analog torque command maximum output	100.0		PC13	TLC	Analog torque command maximum output	100.0		
PC14	MOD1	Analog monitor 1 output	0000h		PC14	MOD1	Analog monitor 1 output	0000h		
PC15	MOD2	Analog monitor 2 output	0001h		PC15	MOD2	Analog monitor 2 output	0001h		
PC16	MBR	Electromagnetic brake sequence output	100		PC16	MBR	Electromagnetic brake sequence output	0		
PC17	ZSP	Zero speed	50		PC17	ZSP	Zero speed	50		
PC18	*BPS	Alarm history clear	0000h		PC18	*BPS	Alarm history clear	0000h		
PC19	*ENRS	Encoder output pulses selection	0000h		PC19	*ENRS	Encoder output pulse selection	0000h		
PC20	*SNO	Station number setting	0		PC20	*SNO	Station No. setting	0		
PC21	*SOP	Absolute position detection system	0000h		PC21	*SOP	RS-422 communication function selection (RS-232C communication is not available.)	0000h		
PC22	*COP1	Function selection C-1	0000h		PC22	*COP1	Function selection C-1	0000h		
PC23	*COP2	Function selection C-2	0000h		PC23	*COP2	Function selection C-2	0000h		
PC24	*COP3	Function selection C-3	0000h		PC24	*COP3	Function selection C-3	0000h		
PC25		For manufacturer setting	0000h		PC25		For manufacturer setting	0000h		
PC26	*COP5	Function selection C-5	0000h		PC26	*COP5	Function selection C-5	0000h		
PC27	*COP6	Function selection C-6	0000h		PC27	*COP6	Function selection C-6	0000h		
PC28		For manufacturer setting	0000h		PC28	*COP7	Function selection C-7	0000h		
PC29			0000h		PC29		For manufacturer setting	0000h		
PC30	STA2	Acceleration time constant 2	0		PC30	STA2	Acceleration time constant 2	0		
PC31	STB2	Deceleration time constant 2	0		PC31	STB2	Deceleration time constant 2	0		
PC32	CMX2	Command pulse multiplying factor numerator 2	1		PC32	CMX2	Command input pulse multiplication numerator 2	1		
PC33	CMX3	Command pulse multiplying factor numerator 3	1		PC33	CMX3	Command input pulse multiplication numerator 3	1		
PC34	CMX4	Command pulse multiplying factor numerator 4	1		PC34	CMX4	Command input pulse multiplication numerator 4	1		
PC35	TL2	Internal torque limit 2	100.0		PC35	TL2	Internal torque limit 2	100.0		
PC36	*DMD	Status display selection	0000h		PC36	*DMD	Status display selection	0000h		
PC37	VCO	Absolute position detection system	0		PC37	VCO	Analog speed command offset		The value differs depending on the servo amplifiers	
		Analog speed limit offset					Analog speed limit offset			
PC38	TPO	Analog torque command offset	0		PC38	TPO	Analog torque command offset	0		
		Analog torque limit offset					Analog torque limit offset			
PC39	MO1	Analog monitor 1 offset	0		PC39	MO1	Analog monitor 1 offset	0		
PC40	MO2	Analog monitor 2 offset	0		PC40	MO2	Analog monitor 2 offset	0		
PC41		For manufacturer setting	0		PC41		For manufacturer setting	0		
PC42			0		PC42			0		
PC43			0000h		PC43	ERZ		Error excessive alarm detection level	0	
PC44			0000h		PC44	*COP9		Function selection C-9	0000h	
PC45			0000h		PC45	*COPA		Function selection C-A	0000h	
PC46			0000h		PC46			For manufacturer setting	0	
PC47			0000h		PC47				0	
PC48			0000h		PC48				0	
PC49			0000h		PC49				0	
PC50			0000h		PC50				0000h	

Part 2: Review on Replacement of MR-J3- _A_ with MR-J4- _A_

MR-J3- _A_ parameters					MR-J4- _A_ parameters				
No.	Abbreviation	Parameter name	Initial value	Customer setting value	No.	Abbreviation	Parameter name	Initial value	Customer setting value
PD01	*DIA1	Input signal automatic ON selection 1	0000h		PD01	*DIA1	Input signal automatic on selection 1	0000h	
PD02		For manufacturer setting	0000h		PD02		For manufacturer setting	0000h	
PD03	*DI1	Input signal device selection 1 (CN1-15)	00020202h		PD03	*DI1L	Input device selection 1L	0202h	
PD04	*DI2	Input signal device selection 2 (CN1-16)	00212100h		PD04	*DI1H	Input device selection 1H	0202h	
PD05	*DI3	Input signal device selection 3 (CN1-17)	00070704h		PD05	*DI2L	Input device selection 2L	2100h	
PD06	*DI4	Input signal device selection 4 (CN1-18)	00080805h		PD06	*DI2H	Input device selection 2H	2021h	
PD07	*DI5	Input signal device selection 5 (CN1-19)	00030303h		PD07	*DI3L	Input device selection 3L	0704h	
PD08	*DI6	Input signal device selection 6 (CN1-41)	00202006h		PD08	*DI3H	Input device selection 3H	0707h	
PD09		For manufacturer setting	00000000h		PD09	*DI4L	Input device selection 4L	0805h	
PD10	*DI8	Input signal device selection 8 (CN1-43)	00000A0Ah		PD10	*DI4H	Input device selection 4H	0808h	
PD11	*DI9	Input signal device selection 9 (CN1-44)	00000B0Bh		PD11	*DI5L	Input device selection 5L	0303h	
PD12	*DI10	Input signal device selection 10 (CN1-45)	00232323h		PD12	*DI5H	Input device selection 5H	3803h	
PD13	*DO1	Output signal device selection 1 (CN1-22)	0004h		PD13	*DI6L	Input device selection 6L	2006h	
PD14	*DO2	Output signal device selection 2 (CN1-23)	000Ch		PD14	*DI6H	Input device selection 6H	3920h	
PD15	*DO3	Output signal device selection 3 (CN1-24)	0004h		PD15		For manufacturer setting	0000h	
PD16	*DO4	Output signal device selection 4 (CN1-25)	0007h		PD16		For manufacturer setting	0000h	
PD17		For manufacturer setting	0003h		PD17	*DI8L	Input device selection 8L	0A0Ah	
PD18	*DO6	Output signal device selection 6 (CN1-49)	0002h		PD18	*DI8H	Input device selection 8H	0A00h	
PD19	*DIF	Input filter setting	0002h		PD19	*DI9L	Input device selection 9L	0B0Bh	
PD20	*DOP1	Function selection D-1	0000h		PD20	*DI9H	Input device selection 9H	0B00h	
PD21		For manufacturer setting	0000h		PD21	*DI10L	Input device selection 10L	2323h	
PD22	*DOP3	Function selection D-3	0000h		PD22	*DI10H	Input device selection 10H	2B23h	
PD23		For manufacturer setting	0000h		PD23	*DO1	Output device selection 1	0004h	
PD24	*DOP5	Function selection D-5	0000h		PD24	*DO2	Output device selection 2	000Ch	
PD25		For manufacturer setting	0000h		PD25	*DO3	Output device selection 3	0004h	
PD26			0000h		PD26	*DO4	Output device selection 4	0007h	
PD27			0000h		PD27		For manufacturer setting	0003h	
PD28			0000h		PD28	*DO6	Output device selection 6	0002h	
PD29			0000h		PD29	*DIF	Input filter setting	0004h	
PD30			0000h		PD30	*DOP1	Function selection D-1	0000h	
					PD31	*DOP2	Function selection D-2	0000h	
					PD32	*DOP3	Function selection D-3	0000h	
					PD33	*DOP4	Function selection D-4	0000h	
					PD34	*DOP5	Function selection D-5	0000h	
					PD35		For manufacturer setting	0000h	
					PD36			0000h	
					PD37			0000h	
					PD38			0	
					PD39			0	
					PD40			0	

Part 2: Review on Replacement of MR-J3- _A_ with MR-J4- _A_

MR-J3- _A_			MR-J4- _A_			Control mode
No.	Name and function	Initial value	No.	Name and function	Initial value	
PA02	<p>Regenerative option Turn off the power and then on again after setting the parameter to validate the parameter value. Incorrect setting may cause the regenerative option to burn. If the regenerative option selected is not for use with the servo amplifier, [AL. 37 Parameter error] occurs. Set this parameter when using the regenerative option, brake unit, power regenerative converter, or power regenerative common converter.</p> <p>0 0 x x: Selection of regenerative option 00: Regenerative option is not used</p> <ul style="list-style-type: none"> ▪ For servo amplifier of 100 W, regenerative resistor is not used. ▪ For servo amplifier of 0.2 kW to 7 kW, built-in regenerative resistor is used. ▪ Supplied regenerative resistors or regenerative option is used with the servo amplifier of 11 kW to 22 kW. <p>01: FR-BU2-(H)/FR-RC-(H)/FR-CV-(H) 02: MR-RB032 03: MR-RB12 04: MR-RB32 05: MR-RB30 06: MR-RB50 (Cooling fanis required) 08: MR-RB31 09: MR-RB51 (Cooling fanis required) 80: MR-RB1H-4 81: MR-RB3M-4 (Cooling fanis required) 82: MR-RB3G-4 (Cooling fanis required) 83: MR-RB5G-4 (Cooling fanis required) 84: MR-RB34-4 (Cooling fanis required) 85: MR-RB54-4 (Cooling fanis required) FA: When the supplied regenerative resistor is cooled by the cooling fan to increase the ability with the servo amplifier of 11 kW to 22 kW.</p>	0000h	PA02	Same setting as MR-J3	00h	P S T
				<p>Regenerative option __ x x: Select the regenerative option. Incorrect setting may cause the regenerative option to burn. If a selected regenerative option is not for use with the servo amplifier, [AL. 37 Parameter error] occurs.</p> <p>00: Regenerative option is not used.</p> <ul style="list-style-type: none"> ▪ For the servo amplifier of 100 W, a regenerative resistor is not used. ▪ For the servo amplifier of 0.2 kW to 7 kW, the built-in regenerative resistor is used. ▪ The supplied regenerative resistor or a regenerative option is used with the servo amplifier of 11 kW to 22 kW. <p>01: FR-RC-(H)/FR-CV-(H)/FR-BU2-(H) When you use FR-RC-(H) or FR-CV-(H), select "Mode 2 (_ _ _ 1)" of "Undervoltage alarm detection mode selection" in [Pr. PC27]. 02: MR-RB032 03: MR-RB12 04: MR-RB32 05: MR-RB30 06: MR-RB50 (Cooling fan is required.) 08: MR-RB31 09: MR-RB51 (Cooling fan is required.) 0B: MR-RB3N 0C: MR-RB5N (Cooling fan is required.) 80: MR-RB1H-4 81: MR-RB3M-4 (Cooling fan is required.) 82: MR-RB3G-4 (Cooling fan is required.) 83: MR-RB5G-4 (Cooling fan is required.) 84: MR-RB34-4 (Cooling fan is required.) 85: MR-RB54-4 (Cooling fan is required.) 91: MR-RB3U-4 (Cooling fan is required.) 92: MR-RB5U-4 (Cooling fan is required.) FA: When the supplied regenerative resistor or a regenerative option used with the servo amplifier of 11 kW to 22 kW is cooled by a cooling fan to increase regenerative ability.</p>		
				<p>_ x _ _ : For manufacturer setting</p>		
				<p>x _ _ _ : For manufacturer setting</p>	0h	

Part 2: Review on Replacement of MR-J3- _A_ with MR-J4- _A_

MR-J3- _A_			MR-J4- _A_			Control mode																																																														
No.	Name and function	Initial value	No.	Name and function	Initial value																																																															
PA03	<p>Absolute position detection system</p> <p>Turn off the power and then on again after setting the parameter to validate the parameter value.</p> <p>Set this parameter when using the absolute position detection system in the position control mode.</p> <p>0 0 0 x:</p> <p>Selection of absolute position detection system</p> <p>0: Used in incremental system</p> <p>1: Used in absolute position detection system ABS transfer by DIO</p> <p>2: Used in absolute position detection system ABS transfer by communication</p>	0000h	PA03	Same setting as MR-J3	0h	P																																																														
				Absolute position detection system																																																																
				___ x:																																																																
				Absolute position detection system selection																																																																
	<p>Set this digit when using the absolute position detection system in the position control mode.</p> <p>0: Disabled (incremental system)</p> <p>1: Enabled (absolute position detection system by DIO)</p> <p>2: Enabled (absolute position detection system by communication) (available for the software version A3 or later)</p>																																																																			
	___ x _:			0h																																																																
	For manufacturer setting																																																																			
	_ x _ _:			0h																																																																
	For manufacturer setting																																																																			
	x _ _ _:			0h																																																																
	For manufacturer setting																																																																			
PA04	<p>Function selection A-1</p> <p>Turn off the power and then on again after setting the parameter to validate the parameter value.</p> <p>Set this parameter when assigning the electromagnetic brake to the CN1-23 pin.</p> <p>0 0 0 x:</p> <p>CN1-23 pin function selection</p> <p>0: Output device assigned with [Pr. PD14]</p> <p>1: Electromagnetic brake interlock (MBR)</p>	0000h	PD24	Output device selection 2	0Ch	P S T																																																														
				___ x x:																																																																
				Device selection																																																																
				Any output device can be assigned to the CN1-23 pin.																																																																
	<p>When "Enabled (absolute position detection system by DIO) (___ 1)" is selected in [Pr. PA03], the CN1-23 pin will become ABSB1 (ABS send data bit 1) only during ABS transfer mode.</p> <p>Refer to table 2.1 in [Pr. PD23] for settings.</p>																																																																			
	<p>Table 2.1 Selectable output devices</p> <table border="1"> <thead> <tr> <th rowspan="2">Setting value</th> <th colspan="3">Output device (Note)</th> </tr> <tr> <th>P</th> <th>S</th> <th>T</th> </tr> </thead> <tbody> <tr><td>__ 00</td><td>Always off</td><td>Always off</td><td>Always off</td></tr> <tr><td>__ 02</td><td>RD</td><td>RD</td><td>RD</td></tr> <tr><td>__ 03</td><td>ALM</td><td>ALM</td><td>ALM</td></tr> <tr><td>__ 04</td><td>INP</td><td>SA</td><td>Always off</td></tr> <tr><td>__ 05</td><td>MBR</td><td>MBR</td><td>MBR</td></tr> <tr><td>__ 06</td><td>DB</td><td>DB</td><td>DB</td></tr> <tr><td>__ 07</td><td>TLC</td><td>TLC</td><td>VLC</td></tr> <tr><td>__ 08</td><td>WNG</td><td>WNG</td><td>WNG</td></tr> <tr><td>__ 09</td><td>BWNG</td><td>BWNG</td><td>BWNG</td></tr> <tr><td>__ 0A</td><td>Always off</td><td>SA</td><td>Always off</td></tr> <tr><td>__ 0B</td><td>Always off</td><td>Always off</td><td>VLC</td></tr> <tr><td>__ 0C</td><td>ZSP</td><td>ZSP</td><td>ZSP</td></tr> <tr><td>__ 0F</td><td>CDPS</td><td>Always off</td><td>Always off</td></tr> <tr><td>__ 11</td><td>ABSV</td><td>Always off</td><td>Always off</td></tr> </tbody> </table>			Setting value	Output device (Note)			P	S	T	__ 00	Always off	Always off	Always off	__ 02	RD	RD	RD	__ 03	ALM	ALM	ALM	__ 04	INP	SA	Always off	__ 05	MBR	MBR	MBR	__ 06	DB	DB	DB	__ 07	TLC	TLC	VLC	__ 08	WNG	WNG	WNG	__ 09	BWNG	BWNG	BWNG	__ 0A	Always off	SA	Always off	__ 0B	Always off	Always off	VLC	__ 0C	ZSP	ZSP	ZSP	__ 0F	CDPS	Always off	Always off	__ 11	ABSV	Always off	Always off		
Setting value	Output device (Note)																																																																			
	P	S	T																																																																	
__ 00	Always off	Always off	Always off																																																																	
__ 02	RD	RD	RD																																																																	
__ 03	ALM	ALM	ALM																																																																	
__ 04	INP	SA	Always off																																																																	
__ 05	MBR	MBR	MBR																																																																	
__ 06	DB	DB	DB																																																																	
__ 07	TLC	TLC	VLC																																																																	
__ 08	WNG	WNG	WNG																																																																	
__ 09	BWNG	BWNG	BWNG																																																																	
__ 0A	Always off	SA	Always off																																																																	
__ 0B	Always off	Always off	VLC																																																																	
__ 0C	ZSP	ZSP	ZSP																																																																	
__ 0F	CDPS	Always off	Always off																																																																	
__ 11	ABSV	Always off	Always off																																																																	
	___ x _ _:			0h																																																																
	For manufacturer setting																																																																			
	x _ _ _:			0h																																																																
	For manufacturer setting																																																																			

Part 2: Review on Replacement of MR-J3- _A_ with MR-J4- _A_

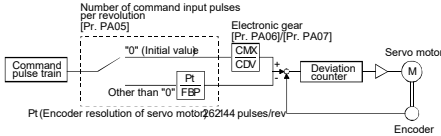
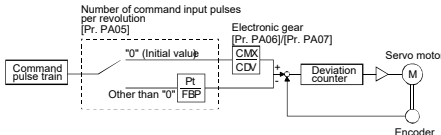
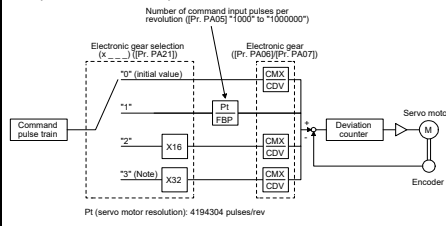
MR-J3- _A_			MR-J4- _A_									
No.	Name and function	Initial value	No.	Name and function	Initial value	Control mode						
PA05	<p>Number of command input pulses per revolution</p> <p>Turn off the power and then on again after setting the parameter to validate the parameter value.</p> <p>When "0" (initial value) is set in [Pr. PA05], the electronic gear ([Pr. PA06, PA07]) is made valid.</p> <p>When the setting is other than "0", that value is used as the command input pulses necessary to rotate the servo motor one turn. At this time, the electronic gear is made invalid.</p>  <table border="1" data-bbox="236 757 678 940"> <thead> <tr> <th>[Pr. PA05] setting</th> <th>Description</th> </tr> </thead> <tbody> <tr> <td>0</td> <td>Electronic gear ([Pr. PA06]/[Pr. PA07]) is made valid.</td> </tr> <tr> <td>1000 to 50000</td> <td>Number of command input pulses necessary to rotate the servo motor one turn [pulse]</td> </tr> </tbody> </table>	[Pr. PA05] setting	Description	0	Electronic gear ([Pr. PA06]/[Pr. PA07]) is made valid.	1000 to 50000	Number of command input pulses necessary to rotate the servo motor one turn [pulse]	0	PA05	<p>Number of command input pulses per revolution</p> <p>The servo motor rotates based on set command input pulses.</p> <p>To enable the parameter value, set "Electronic gear selection" to "Number of command input pulses per revolution (1 ___)" of in [Pr. PA21].</p> <p>Setting range: 1000 to 1000000</p>	10000	P
[Pr. PA05] setting	Description											
0	Electronic gear ([Pr. PA06]/[Pr. PA07]) is made valid.											
1000 to 50000	Number of command input pulses necessary to rotate the servo motor one turn [pulse]											
PA06 PA07	<p>Electronic gear numerator (command pulse multiplying factor numerator)</p> <p>Electronic gear denominator (command pulse multiplying factor denominator)</p> <p>Incorrect setting can lead to unexpected fast rotation, causing injury.</p> <p>The electronic gear setting range is</p> $\frac{1}{10} < \frac{CMX}{CDV} < 2000$ <p>If the set value is outside this range, noise may be generated during acceleration/ deceleration or operation may not be performed at the preset speed and/or acceleration/deceleration time constants.</p> <p>Always set the electronic gear with servo off state to prevent unexpected operation due to improper setting.</p> <p>Concept of electronic gear</p> <p>The machine can be moved at any multiplication factor to input pulses.</p>  $\frac{CMX}{CDV} = \frac{[Pr. PA06]}{[Pr. PA07]}$	1 1	PA06	<p>Electronic gear numerator (command pulse multiplication numerator)</p> <p>Set the numerator of the electronic gear.</p> <p>To enable the parameter, select "Electronic gear (0 ___)" or "J3 electronic gear setting value compatibility mode (2 ___)" of "Electronic gear selection" in [Pr. PA21].</p> <p>The following shows a standard of the setting range of the electronic gear.</p> $\frac{1}{10} < \frac{CMX}{CDV} < 4000$ <p>If the set value is outside this range, noise may be generated during acceleration/deceleration or operation may not be performed at the preset speed and/or acceleration/deceleration time constants.</p>  <p>Note. This parameter is available with servo amplifiers with software version B3 or later.</p> <p>Always set the electronic gear with servo-off state to prevent unexpected operation due to improper setting.</p> <p>Setting range: 1 to 16777215</p>	1	P						
			PA07	<p>Electronic gear denominator (command pulse multiplication denominator)</p> <p>Set the denominator of the electronic gear.</p> <p>To enable the parameter, select "Electronic gear (0 ___)" or "J3 electronic gear setting value compatibility mode (2 ___)" of "Electronic gear selection" in [Pr. PA21].</p> <p>Setting range: 1 to 16777215</p>	1	P						

Part 2: Review on Replacement of MR-J3- _A_ with MR-J4- _A_

MR-J3- _A_			MR-J4- _A_			Control mode																																																																																																																																																							
No.	Name and function	Initial value	No.	Name and function	Initial value																																																																																																																																																								
PA08	Auto tuning mode	0001h	PA08	Same setting as MR-J3	1h	P S																																																																																																																																																							
PA09	Auto tuning response Make gain adjustment using auto tuning. Auto tuning mode [Pr. PA08] Select the gain adjustment mode. 0 0 0 x: Gain adjustment mode setting 0: Interpolation mode (Automatically set parameter No. [Pr. PB06/PB08/PB09/PB10]) 1: Auto tuning mode 1 (Automatically set parameter No. [Pr. PB06/ PB07/PB08/PB09/PB10]) 2: Auto tuning mode 2 (Automatically set parameter No. [Pr. PB07/PB08/PB09/PB10]) 3: Manual mode Note. The parameters have the following names.	12		Auto tuning mode ____ x: Gain adjustment mode selection Select the gain adjustment mode. 0: 2 gain adjustment mode 1 (interpolation mode) 1: Auto tuning mode 1 2: Auto tuning mode 2 3: Manual mode 4: 2 gain adjustment mode 2 Refer to table 2.2 for details.																																																																																																																																																									
<table border="1"> <thead> <tr> <th>No.</th> <th>Name</th> </tr> </thead> <tbody> <tr> <td>PB06</td> <td>Ratio of load inertia moment to servo motor inertia moment</td> </tr> <tr> <td>PB07</td> <td>Model loop gain</td> </tr> <tr> <td>PB08</td> <td>Position loop gain</td> </tr> <tr> <td>PB09</td> <td>Speed loop gain</td> </tr> <tr> <td>PB10</td> <td>Speed integral compensation</td> </tr> </tbody> </table>				No.			Name	PB06	Ratio of load inertia moment to servo motor inertia moment	PB07	Model loop gain	PB08	Position loop gain	PB09	Speed loop gain	PB10	Speed integral compensation	<table border="1"> <caption>Table2.2 Gain adjustment mode selection</caption> <thead> <tr> <th>Setting value</th> <th>Gain adjustment mode</th> <th>Automatically adjusted parameter</th> </tr> </thead> <tbody> <tr> <td>___ 0</td> <td>2 gain adjustment mode 1 (interpolation mode)</td> <td>[Pr. PB06 Load to motor inertia ratio] [Pr. PB08 Position loop gain] [Pr. PB09 Speed loop gain] [Pr. PB10 Speed integral compensation]</td> </tr> <tr> <td>___ 1</td> <td>Auto tuning mode 1</td> <td>[Pr. PB06 Load to motor inertia ratio] [Pr. PB07 Model loop gain] [Pr. PB08 Position loop gain] [Pr. PB09 Speed loop gain] [Pr. PB10 Speed integral compensation]</td> </tr> <tr> <td>___ 2</td> <td>Auto tuning mode 2</td> <td>[Pr. PB07 Model loop gain] [Pr. PB08 Position loop gain] [Pr. PB09 Speed loop gain] [Pr. PB10 Speed integral compensation]</td> </tr> <tr> <td>___ 3</td> <td>Manual mode</td> <td></td> </tr> <tr> <td>___ 4</td> <td>2 gain adjustment mode 2</td> <td>[Pr. PB08 Position loop gain] [Pr. PB09 Speed loop gain] [Pr. PB10 Speed integral compensation]</td> </tr> </tbody> </table>	Setting value	Gain adjustment mode	Automatically adjusted parameter	___ 0	2 gain adjustment mode 1 (interpolation mode)	[Pr. PB06 Load to motor inertia ratio] [Pr. PB08 Position loop gain] [Pr. PB09 Speed loop gain] [Pr. PB10 Speed integral compensation]	___ 1	Auto tuning mode 1	[Pr. PB06 Load to motor inertia ratio] [Pr. PB07 Model loop gain] [Pr. PB08 Position loop gain] [Pr. PB09 Speed loop gain] [Pr. PB10 Speed integral compensation]	___ 2	Auto tuning mode 2	[Pr. PB07 Model loop gain] [Pr. PB08 Position loop gain] [Pr. PB09 Speed loop gain] [Pr. PB10 Speed integral compensation]	___ 3	Manual mode		___ 4	2 gain adjustment mode 2	[Pr. PB08 Position loop gain] [Pr. PB09 Speed loop gain] [Pr. PB10 Speed integral compensation]																																																																																																																									
No.	Name																																																																																																																																																												
PB06	Ratio of load inertia moment to servo motor inertia moment																																																																																																																																																												
PB07	Model loop gain																																																																																																																																																												
PB08	Position loop gain																																																																																																																																																												
PB09	Speed loop gain																																																																																																																																																												
PB10	Speed integral compensation																																																																																																																																																												
Setting value	Gain adjustment mode	Automatically adjusted parameter																																																																																																																																																											
___ 0	2 gain adjustment mode 1 (interpolation mode)	[Pr. PB06 Load to motor inertia ratio] [Pr. PB08 Position loop gain] [Pr. PB09 Speed loop gain] [Pr. PB10 Speed integral compensation]																																																																																																																																																											
___ 1	Auto tuning mode 1	[Pr. PB06 Load to motor inertia ratio] [Pr. PB07 Model loop gain] [Pr. PB08 Position loop gain] [Pr. PB09 Speed loop gain] [Pr. PB10 Speed integral compensation]																																																																																																																																																											
___ 2	Auto tuning mode 2	[Pr. PB07 Model loop gain] [Pr. PB08 Position loop gain] [Pr. PB09 Speed loop gain] [Pr. PB10 Speed integral compensation]																																																																																																																																																											
___ 3	Manual mode																																																																																																																																																												
___ 4	2 gain adjustment mode 2	[Pr. PB08 Position loop gain] [Pr. PB09 Speed loop gain] [Pr. PB10 Speed integral compensation]																																																																																																																																																											
Auto tuning response [Pr. PA09] If the machine hunts or generates large gear sound, decrease the set value. To improve performance, e.g. shorten the settling time, increase the set value.			<table border="1"> <thead> <tr> <th>Setting value</th> <th>Response</th> <th>Guideline for machine resonance frequency [Hz]</th> </tr> </thead> <tbody> <tr><td>1</td><td>Low response</td><td>10.0</td></tr> <tr><td>2</td><td></td><td>11.3</td></tr> <tr><td>3</td><td></td><td>12.7</td></tr> <tr><td>4</td><td></td><td>14.3</td></tr> <tr><td>5</td><td></td><td>16.1</td></tr> <tr><td>6</td><td></td><td>18.1</td></tr> <tr><td>7</td><td></td><td>20.4</td></tr> <tr><td>8</td><td></td><td>23.0</td></tr> <tr><td>9</td><td></td><td>25.9</td></tr> <tr><td>10</td><td></td><td>29.2</td></tr> <tr><td>11</td><td></td><td>32.9</td></tr> <tr><td>12</td><td></td><td>37.0</td></tr> <tr><td>13</td><td></td><td>41.7</td></tr> <tr><td>14</td><td></td><td>47.0</td></tr> <tr><td>15</td><td></td><td>52.9</td></tr> <tr><td>16</td><td>Middle response</td><td>59.6</td></tr> </tbody> </table> <table border="1"> <thead> <tr> <th>Setting</th> <th>Response</th> <th>Guideline for machine resonance frequency [Hz]</th> </tr> </thead> <tbody> <tr><td>17</td><td>Middle response</td><td>67.1</td></tr> <tr><td>18</td><td></td><td>75.6</td></tr> <tr><td>19</td><td></td><td>85.2</td></tr> <tr><td>20</td><td></td><td>95.9</td></tr> <tr><td>21</td><td></td><td>108.0</td></tr> <tr><td>22</td><td></td><td>121.7</td></tr> <tr><td>23</td><td></td><td>137.1</td></tr> <tr><td>24</td><td></td><td>154.4</td></tr> <tr><td>25</td><td></td><td>173.9</td></tr> <tr><td>26</td><td></td><td>195.9</td></tr> <tr><td>27</td><td></td><td>220.6</td></tr> <tr><td>28</td><td></td><td>248.5</td></tr> <tr><td>29</td><td></td><td>279.9</td></tr> <tr><td>30</td><td></td><td>315.3</td></tr> <tr><td>31</td><td></td><td>355.1</td></tr> <tr><td>32</td><td>High response</td><td>400.0</td></tr> </tbody> </table>	Setting value	Response	Guideline for machine resonance frequency [Hz]	1	Low response	10.0	2		11.3	3		12.7	4		14.3	5		16.1	6		18.1	7		20.4	8		23.0	9		25.9	10		29.2	11		32.9	12		37.0	13		41.7	14		47.0	15		52.9	16	Middle response	59.6	Setting	Response	Guideline for machine resonance frequency [Hz]	17	Middle response	67.1	18		75.6	19		85.2	20		95.9	21		108.0	22		121.7	23		137.1	24		154.4	25		173.9	26		195.9	27		220.6	28		248.5	29		279.9	30		315.3	31		355.1	32	High response	400.0	<table border="1"> <thead> <tr> <th>Setting value</th> <th>Response</th> <th>Guideline for machine resonance frequency [Hz]</th> </tr> </thead> <tbody> <tr><td>17</td><td>Middle response</td><td>67.1</td></tr> <tr><td>18</td><td></td><td>75.6</td></tr> <tr><td>19</td><td></td><td>85.2</td></tr> <tr><td>20</td><td></td><td>95.9</td></tr> <tr><td>21</td><td></td><td>108.0</td></tr> <tr><td>22</td><td></td><td>121.7</td></tr> <tr><td>23</td><td></td><td>137.1</td></tr> <tr><td>24</td><td></td><td>154.4</td></tr> <tr><td>25</td><td></td><td>173.9</td></tr> <tr><td>26</td><td></td><td>195.9</td></tr> <tr><td>27</td><td></td><td>220.6</td></tr> <tr><td>28</td><td></td><td>248.5</td></tr> <tr><td>29</td><td></td><td>279.9</td></tr> <tr><td>30</td><td></td><td>315.3</td></tr> <tr><td>31</td><td></td><td>355.1</td></tr> <tr><td>32</td><td>High response</td><td>400.0</td></tr> </tbody> </table>	Setting value	Response	Guideline for machine resonance frequency [Hz]	17	Middle response	67.1	18		75.6	19		85.2	20		95.9	21		108.0	22		121.7	23		137.1	24		154.4	25		173.9	26		195.9	27		220.6	28		248.5	29		279.9	30		315.3	31		355.1	32	High response	400.0
Setting value	Response	Guideline for machine resonance frequency [Hz]																																																																																																																																																											
1	Low response	10.0																																																																																																																																																											
2		11.3																																																																																																																																																											
3		12.7																																																																																																																																																											
4		14.3																																																																																																																																																											
5		16.1																																																																																																																																																											
6		18.1																																																																																																																																																											
7		20.4																																																																																																																																																											
8		23.0																																																																																																																																																											
9		25.9																																																																																																																																																											
10		29.2																																																																																																																																																											
11		32.9																																																																																																																																																											
12		37.0																																																																																																																																																											
13		41.7																																																																																																																																																											
14		47.0																																																																																																																																																											
15		52.9																																																																																																																																																											
16	Middle response	59.6																																																																																																																																																											
Setting	Response	Guideline for machine resonance frequency [Hz]																																																																																																																																																											
17	Middle response	67.1																																																																																																																																																											
18		75.6																																																																																																																																																											
19		85.2																																																																																																																																																											
20		95.9																																																																																																																																																											
21		108.0																																																																																																																																																											
22		121.7																																																																																																																																																											
23		137.1																																																																																																																																																											
24		154.4																																																																																																																																																											
25		173.9																																																																																																																																																											
26		195.9																																																																																																																																																											
27		220.6																																																																																																																																																											
28		248.5																																																																																																																																																											
29		279.9																																																																																																																																																											
30		315.3																																																																																																																																																											
31		355.1																																																																																																																																																											
32	High response	400.0																																																																																																																																																											
Setting value	Response	Guideline for machine resonance frequency [Hz]																																																																																																																																																											
17	Middle response	67.1																																																																																																																																																											
18		75.6																																																																																																																																																											
19		85.2																																																																																																																																																											
20		95.9																																																																																																																																																											
21		108.0																																																																																																																																																											
22		121.7																																																																																																																																																											
23		137.1																																																																																																																																																											
24		154.4																																																																																																																																																											
25		173.9																																																																																																																																																											
26		195.9																																																																																																																																																											
27		220.6																																																																																																																																																											
28		248.5																																																																																																																																																											
29		279.9																																																																																																																																																											
30		315.3																																																																																																																																																											
31		355.1																																																																																																																																																											
32	High response	400.0																																																																																																																																																											
			___ x _:	0h																																																																																																																																																									
			For manufacturer setting	0h																																																																																																																																																									
			_ x _:	0h																																																																																																																																																									
			For manufacturer setting	0h																																																																																																																																																									
			x _ _:	0h																																																																																																																																																									
			For manufacturer setting																																																																																																																																																										
			PA09	Auto tuning response Set a response of the auto tuning.	16	P S																																																																																																																																																							
			<table border="1"> <thead> <tr> <th rowspan="2">Setting value</th> <th colspan="2">Machine characteristic</th> <th rowspan="2">Setting value</th> <th colspan="2">Machine characteristic</th> </tr> <tr> <th>Response</th> <th>Guideline for machine resonance frequency [Hz]</th> <th>Response</th> <th>Guideline for machine resonance frequency [Hz]</th> </tr> </thead> <tbody> <tr><td>1</td><td>Low response</td><td>2.7</td><td>21</td><td>Middle response</td><td>67.1</td></tr> <tr><td>2</td><td></td><td>3.6</td><td>22</td><td></td><td>75.6</td></tr> <tr><td>3</td><td></td><td>4.9</td><td>23</td><td></td><td>85.2</td></tr> <tr><td>4</td><td></td><td>6.6</td><td>24</td><td></td><td>95.9</td></tr> <tr><td>5</td><td></td><td>10.0</td><td>25</td><td></td><td>108.0</td></tr> <tr><td>6</td><td></td><td>11.3</td><td>26</td><td></td><td>121.7</td></tr> <tr><td>7</td><td></td><td>12.7</td><td>27</td><td></td><td>137.1</td></tr> <tr><td>8</td><td></td><td>14.3</td><td>28</td><td></td><td>154.4</td></tr> <tr><td>9</td><td></td><td>16.1</td><td>29</td><td></td><td>173.9</td></tr> <tr><td>10</td><td></td><td>18.1</td><td>30</td><td></td><td>195.9</td></tr> <tr><td>11</td><td></td><td>20.4</td><td>31</td><td></td><td>220.6</td></tr> <tr><td>12</td><td></td><td>23.0</td><td>32</td><td></td><td>248.5</td></tr> <tr><td>13</td><td></td><td>25.9</td><td>33</td><td></td><td>279.9</td></tr> <tr><td>14</td><td></td><td>29.2</td><td>34</td><td></td><td>315.3</td></tr> <tr><td>15</td><td></td><td>32.9</td><td>35</td><td></td><td>355.1</td></tr> <tr><td>16</td><td></td><td>37.0</td><td>36</td><td></td><td>400.0</td></tr> <tr><td>17</td><td></td><td>41.7</td><td>37</td><td></td><td>446.6</td></tr> <tr><td>18</td><td></td><td>47.0</td><td>38</td><td></td><td>501.2</td></tr> <tr><td>19</td><td></td><td>52.9</td><td>39</td><td></td><td>571.5</td></tr> <tr><td>20</td><td>Middle response</td><td>59.6</td><td>40</td><td>High response</td><td>642.7</td></tr> </tbody> </table>			Setting value	Machine characteristic		Setting value	Machine characteristic		Response	Guideline for machine resonance frequency [Hz]	Response	Guideline for machine resonance frequency [Hz]	1	Low response	2.7	21	Middle response	67.1	2		3.6	22		75.6	3		4.9	23		85.2	4		6.6	24		95.9	5		10.0	25		108.0	6		11.3	26		121.7	7		12.7	27		137.1	8		14.3	28		154.4	9		16.1	29		173.9	10		18.1	30		195.9	11		20.4	31		220.6	12		23.0	32		248.5	13		25.9	33		279.9	14		29.2	34		315.3	15		32.9	35		355.1	16		37.0	36		400.0	17		41.7	37		446.6	18		47.0	38		501.2	19		52.9	39		571.5	20	Middle response	59.6	40	High response	642.7																						
Setting value	Machine characteristic		Setting value	Machine characteristic																																																																																																																																																									
	Response	Guideline for machine resonance frequency [Hz]		Response	Guideline for machine resonance frequency [Hz]																																																																																																																																																								
1	Low response	2.7	21	Middle response	67.1																																																																																																																																																								
2		3.6	22		75.6																																																																																																																																																								
3		4.9	23		85.2																																																																																																																																																								
4		6.6	24		95.9																																																																																																																																																								
5		10.0	25		108.0																																																																																																																																																								
6		11.3	26		121.7																																																																																																																																																								
7		12.7	27		137.1																																																																																																																																																								
8		14.3	28		154.4																																																																																																																																																								
9		16.1	29		173.9																																																																																																																																																								
10		18.1	30		195.9																																																																																																																																																								
11		20.4	31		220.6																																																																																																																																																								
12		23.0	32		248.5																																																																																																																																																								
13		25.9	33		279.9																																																																																																																																																								
14		29.2	34		315.3																																																																																																																																																								
15		32.9	35		355.1																																																																																																																																																								
16		37.0	36		400.0																																																																																																																																																								
17		41.7	37		446.6																																																																																																																																																								
18		47.0	38		501.2																																																																																																																																																								
19		52.9	39		571.5																																																																																																																																																								
20	Middle response	59.6	40	High response	642.7																																																																																																																																																								
			Setting range: 1 to 40																																																																																																																																																										

Part 2: Review on Replacement of MR-J3- _A_ with MR-J4- _A_

MR-J3- _A_			MR-J4- _A_			Control mode
No.	Name and function	Initial value	No.	Name and function	Initial value	
PA10	<p>In-position range</p> <p>Set the range, where In-position (INP) is output, in the command pulse unit before calculation of the electronic gear. With the setting of [Pr. PC24], the range can be changed to the encoder output pulse unit.</p> <p>Command pulse Droop pulse In-position (INP) ON OFF</p>	100	PA10	<p>In-position range</p> <p>Set an in-position range per command pulse. To change it to the servo motor encoder pulse unit, set [Pr. PC24].</p> <p>Setting range: 0 to 65535</p>	100	P
PA11	<p>Forward rotation torque limit</p>	100.0	PA11	<p>Same as MR-J3</p>	100.0	P S T
PA12	<p>Reverse rotation torque limit</p> <p>The torque generated by the servo motor can be limited.</p> <p>When torque is output with the analog monitor output, the smaller torque of the values in the [Pr. PA11] (forward rotation torque limit) and [Pr. PA12] (reverse rotation torque limit) is the maximum output voltage (8V).</p> <p>(1) Forward rotation torque limit [Pr. PA11] Set this parameter on the assumption that the maximum torque is 100 [%]. Set this parameter when limiting the torque of the servo motor in the CCW driving mode or CW regeneration mode. Set this parameter to "0.0" to generate no torque.</p> <p>(2) Reverse rotation torque limit [Pr. PA12] Set this parameter on the assumption that the maximum torque is 100 [%]. Set this parameter when limiting the torque of the servo motor in the CW driving mode or CCW regeneration mode. Set this parameter to "0.0" to generate no torque.</p>	100.0		<p>Forward rotation torque limit</p> <p>You can limit the torque generated by the servo motor.</p> <p>When the torque is outputted with the analog monitor output, the setting of [Pr. PA11 Forward rotation torque limit] or [Pr. PA12 Reverse rotation torque limit], whichever is larger, will be the maximum output voltage (8 V).</p> <p>Set the parameter on the assumption that the maximum torque is 100.0 [%]. The parameter is for limiting the torque of the servo motor in the CCW power running or CW regeneration. No torque is generated when this parameter is set to "0.0".</p> <p>Setting range: 0.0 to 100.0</p>		
			PA12	<p>Reverse rotation torque limit</p> <p>You can limit the torque generated by the servo motor.</p> <p>When the torque is outputted with the analog monitor output, the setting of [Pr. PA11 Forward rotation torque limit] or [Pr. PA12 Reverse rotation torque limit], whichever is larger, will be the maximum output voltage (8 V).</p> <p>Set the parameter on the assumption that the maximum torque is 100.0 [%]. The parameter is for limiting the torque of the servo motor in the CW power running or CCW regeneration. No torque is generated when this parameter is set to "0.0".</p> <p>Setting range: 0.0 to 100.0</p>	100.0	P S T

Part 2: Review on Replacement of MR-J3- _A_ with MR-J4- _A_

MR-J3- _A_			MR-J4- _A_																																												
No.	Name and function	Initial value	No.	Name and function	Initial value	Control mode																																									
PA13	<p>Command pulse input form</p> <p>Turn off the power and then on again after setting the parameter to validate the parameter value. Select the input form of the pulse train input signal. Command pulses may be input in any of three different forms, for which positive or negative logic can be chosen.</p> <p>Arrow or in the table indicates the timing of importing a pulse train.</p> <p>A- and B-phase pulse trains are imported after they have been multiplied by 4.</p> <p>Selection of command pulse input form</p> <table border="1"> <thead> <tr> <th>Setting</th> <th>Pulse train form</th> <th>Forward rotation command</th> <th>Reverse rotation command</th> </tr> </thead> <tbody> <tr> <td rowspan="2">0010h</td> <td>Forward rotation pulse train</td> <td>PP </td> <td>NP </td> </tr> <tr> <td>Reverse rotation pulse train</td> <td>PP </td> <td>NP </td> </tr> <tr> <td rowspan="2">0011h</td> <td rowspan="2">Signed pulse train</td> <td>PP </td> <td>NP </td> </tr> <tr> <td>PP </td> <td>NP </td> </tr> <tr> <td rowspan="2">0012h</td> <td rowspan="2">A-phase pulse train B-phase pulse train</td> <td>PP </td> <td>NP </td> </tr> <tr> <td>PP </td> <td>NP </td> </tr> <tr> <td rowspan="2">0000h</td> <td rowspan="2">Forward rotation pulse train Reverse rotation pulse train</td> <td>PP </td> <td>NP </td> </tr> <tr> <td>PP </td> <td>NP </td> </tr> <tr> <td rowspan="2">0001h</td> <td rowspan="2">Signed pulse train</td> <td>PP </td> <td>NP </td> </tr> <tr> <td>PP </td> <td>NP </td> </tr> <tr> <td rowspan="2">0002h</td> <td rowspan="2">A-phase pulse train B-phase pulse train</td> <td>PP </td> <td>NP </td> </tr> <tr> <td>PP </td> <td>NP </td> </tr> </tbody> </table>	Setting	Pulse train form	Forward rotation command	Reverse rotation command	0010h	Forward rotation pulse train	PP	NP	Reverse rotation pulse train	PP	NP	0011h	Signed pulse train	PP	NP	PP	NP	0012h	A-phase pulse train B-phase pulse train	PP	NP	PP	NP	0000h	Forward rotation pulse train Reverse rotation pulse train	PP	NP	PP	NP	0001h	Signed pulse train	PP	NP	PP	NP	0002h	A-phase pulse train B-phase pulse train	PP	NP	PP	NP	0000h	PA13	<p>Command pulse input form</p> <p>__ _ x:</p> <p>Command input pulse train form selection</p> <p>0: Forward/reverse rotation pulse train</p> <p>1: Signed pulse train</p> <p>2: A-phase/B-phase pulse train (The servo amplifier imports input pulses after multiplying by four.)</p> <p>Refer to table 2.3 for settings.</p>	0h	P
		Setting	Pulse train form	Forward rotation command	Reverse rotation command																																										
0010h	Forward rotation pulse train	PP	NP																																												
	Reverse rotation pulse train	PP	NP																																												
0011h	Signed pulse train	PP	NP																																												
		PP	NP																																												
0012h	A-phase pulse train B-phase pulse train	PP	NP																																												
		PP	NP																																												
0000h	Forward rotation pulse train Reverse rotation pulse train	PP	NP																																												
		PP	NP																																												
0001h	Signed pulse train	PP	NP																																												
		PP	NP																																												
0002h	A-phase pulse train B-phase pulse train	PP	NP																																												
		PP	NP																																												
<p>__ _ x _:</p> <p>Pulse train logic selection</p> <p>0: Positive logic</p> <p>1: Negative logic</p> <p>Choose the right parameter to match the logic of the command pulse train received from a connected controller. For the logic of MELSEC iQ-R series/MELSEC iQ-F series/MELSEC-Q series/MELSEC-L series/MELSEC-F series, refer to "MR-J4- _A_ (-RJ)/MR-J4-03A6(-RJ) Servo Amplifier Instruction Manual".</p> <p>Refer to table 2.3 for settings.</p>	0h	P																																													
<p>_ x _ _:</p> <p>Command input pulse train filter selection</p> <p>Selecting proper filter enables to enhance noise tolerance.</p> <p>0: Command input pulse train is 4 Mpulses/s or less.</p> <p>1: Command input pulse train is 1 Mpulse/s or less.</p> <p>2: Command input pulse train is 500 kpulses/s or less.</p> <p>3: Command input pulse train is 200 kpulses/s or less (available for the software version A5 or later)</p> <p>1 Mpulse/s or lower commands are supported by "1". When inputting commands over 1 Mpulse/s and 4 Mpulses/s or lower, set "0".</p> <p>Incorrect setting may cause the following malfunctions.</p> <ul style="list-style-type: none"> Setting a value higher than actual command will lower noise tolerance. Setting a value lower than actual command will cause a position mismatch. 	1h	P																																													
<p>x _ _ _:</p> <p>For manufacturer setting</p>	0h																																														
<p>Table 2.3 Command input pulse train form selection</p> <table border="1"> <thead> <tr> <th>Setting value</th> <th>Pulse train form</th> <th>Forward rotation (positive direction) command</th> <th>Reverse rotation (negative direction) command</th> </tr> </thead> <tbody> <tr> <td rowspan="2">__ _ 1 0</td> <td rowspan="2">Forward rotation pulse train (positive direction pulse train) Reverse rotation pulse train (negative direction pulse train)</td> <td>PP </td> <td>NP </td> </tr> <tr> <td>PP </td> <td>NP </td> </tr> <tr> <td rowspan="2">__ _ 1 1</td> <td rowspan="2">Signed pulse train</td> <td>PP </td> <td>NP </td> </tr> <tr> <td>PP </td> <td>NP </td> </tr> <tr> <td rowspan="2">__ _ 1 2</td> <td rowspan="2">A-phase pulse train B-phase pulse train</td> <td>PP </td> <td>NP </td> </tr> <tr> <td>PP </td> <td>NP </td> </tr> <tr> <td rowspan="2">__ _ 0 0</td> <td rowspan="2">Forward rotation pulse train (positive direction pulse train) Reverse rotation pulse train (negative direction pulse train)</td> <td>PP </td> <td>NP </td> </tr> <tr> <td>PP </td> <td>NP </td> </tr> <tr> <td rowspan="2">__ _ 0 1</td> <td rowspan="2">Signed pulse train</td> <td>PP </td> <td>NP </td> </tr> <tr> <td>PP </td> <td>NP </td> </tr> <tr> <td rowspan="2">__ _ 0 2</td> <td rowspan="2">A-phase pulse train B-phase pulse train</td> <td>PP </td> <td>NP </td> </tr> <tr> <td>PP </td> <td>NP </td> </tr> </tbody> </table>						Setting value	Pulse train form	Forward rotation (positive direction) command	Reverse rotation (negative direction) command	__ _ 1 0	Forward rotation pulse train (positive direction pulse train) Reverse rotation pulse train (negative direction pulse train)	PP	NP	PP	NP	__ _ 1 1	Signed pulse train	PP	NP	PP	NP	__ _ 1 2	A-phase pulse train B-phase pulse train	PP	NP	PP	NP	__ _ 0 0	Forward rotation pulse train (positive direction pulse train) Reverse rotation pulse train (negative direction pulse train)	PP	NP	PP	NP	__ _ 0 1	Signed pulse train	PP	NP	PP	NP	__ _ 0 2	A-phase pulse train B-phase pulse train	PP	NP	PP	NP		
Setting value	Pulse train form	Forward rotation (positive direction) command	Reverse rotation (negative direction) command																																												
__ _ 1 0	Forward rotation pulse train (positive direction pulse train) Reverse rotation pulse train (negative direction pulse train)	PP	NP																																												
		PP	NP																																												
__ _ 1 1	Signed pulse train	PP	NP																																												
		PP	NP																																												
__ _ 1 2	A-phase pulse train B-phase pulse train	PP	NP																																												
		PP	NP																																												
__ _ 0 0	Forward rotation pulse train (positive direction pulse train) Reverse rotation pulse train (negative direction pulse train)	PP	NP																																												
		PP	NP																																												
__ _ 0 1	Signed pulse train	PP	NP																																												
		PP	NP																																												
__ _ 0 2	A-phase pulse train B-phase pulse train	PP	NP																																												
		PP	NP																																												
<p>Arrows in the table indicate the timing of importing pulse trains. A-phase and B-phase pulse trains are imported after they have been multiplied by 4.</p>																																															

Part 2: Review on Replacement of MR-J3- _A_ with MR-J4- _A_

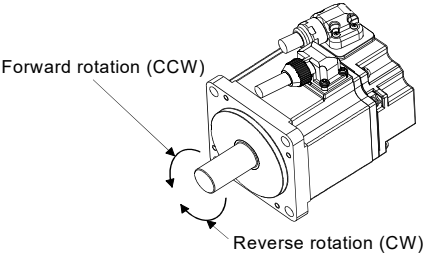
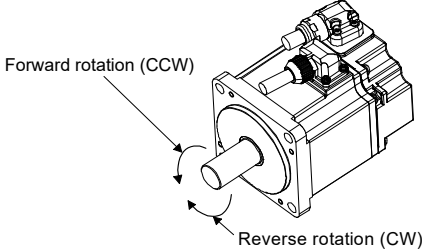
MR-J3- _A_			MR-J4- _A_			Control mode																						
No.	Name and function	Initial value	No.	Name and function	Initial value																							
PA14	<p>Rotation direction selection</p> <p>Turn off the power and then on again after setting the parameter to validate the parameter value.</p> <p>Select servo motor rotation direction relative to the input pulse train.</p> <table border="1"> <thead> <tr> <th rowspan="2">[Pr. PA14] setting</th> <th colspan="2">Servo motor rotation direction</th> </tr> <tr> <th>When forward rotation pulse is input</th> <th>When reverse rotation pulse is input</th> </tr> </thead> <tbody> <tr> <td>0</td> <td>CCW</td> <td>CW</td> </tr> <tr> <td>1</td> <td>CW</td> <td>CCW</td> </tr> </tbody> </table> 	[Pr. PA14] setting	Servo motor rotation direction		When forward rotation pulse is input	When reverse rotation pulse is input	0	CCW	CW	1	CW	CCW	0	PA14	<p>Same as MR-J3</p> <p>Rotation direction selection</p> <p>Select a servo motor rotation direction relative to the input pulse train.</p> <table border="1"> <thead> <tr> <th rowspan="2">Setting value</th> <th colspan="2">Servo motor rotation direction</th> </tr> <tr> <th>When forward rotation pulse is input</th> <th>When reverse rotation pulse is input</th> </tr> </thead> <tbody> <tr> <td>0</td> <td>CCW</td> <td>CW</td> </tr> <tr> <td>1</td> <td>CW</td> <td>CCW</td> </tr> </tbody> </table> <p>The following shows the servo motor rotation directions.</p>  <p>Setting range: 0, 1</p>	Setting value	Servo motor rotation direction		When forward rotation pulse is input	When reverse rotation pulse is input	0	CCW	CW	1	CW	CCW	0	P
[Pr. PA14] setting	Servo motor rotation direction																											
	When forward rotation pulse is input	When reverse rotation pulse is input																										
0	CCW	CW																										
1	CW	CCW																										
Setting value	Servo motor rotation direction																											
	When forward rotation pulse is input	When reverse rotation pulse is input																										
0	CCW	CW																										
1	CW	CCW																										

Part 2: Review on Replacement of MR-J3- _A_ with MR-J4- _A_

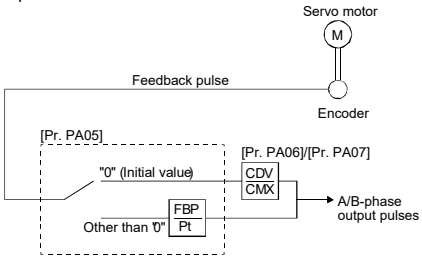
MR-J3- _A_			MR-J4- _A_			
No.	Name and function	Initial value	No.	Name and function	Initial value	Control mode
PA15	<p>Encoder output pulse</p> <p>Turn off the power and then on again after setting the parameter to validate the parameter value.</p> <p>Used to set the encoder pulses (A-phase, B-phase) output by the servo amplifier.</p> <p>You can use parameter [Pr. PC19] to choose the output pulse setting or output division ratio setting.</p> <p>The number of A/B-phase pulses actually output is 1/4 times greater than the preset number of pulses.</p> <p>The maximum output frequency is 4.6 Mpulses/s (after multiplication by 4). Use this parameter within this range.</p> <p>(1) For output pulse designation Set " _ _ 0 _ " (initial value) in [Pr. PC19]. Set the number of pulses per servo motor revolution.</p> <p>Output pulse = set value [pulses/rev] For instance, set "5600" to [Pr. PA15], the actually output A/B-phase pulses are as indicated below.</p> $\text{A/B-phase output pulses} = \frac{5600}{4} = 1400 \text{ pulses}$ <p>(2) For output division ratio setting Set "0 0 1 0" in parameter [Pr. PC19] The number of pulses per servo motor revolution is divided by the set value.</p> $\text{Output pulse} = \frac{\text{Resolution per servo motor revolution [pulses/rev]}}{\text{Set value}}$ <p>For instance, set "8" to [Pr. PA15], the actually A/B-phase pulses output are as indicated below.</p> $\text{A/B-phase output pulses} = \frac{262144}{8} \cdot \frac{1}{4} = 8192 \text{ pulses}$ <p>(3) When outputting pulse train similar to command pulses Set [Pr. PC19] to " _ _ 2 _ ". The feedback pulses from the servo motor encoder are processed and output as shown below. The feedback pulses can be output in the same pulse unit as the command pulses.</p> 	4000	PA15	<p>Set the encoder output pulses from the servo amplifier by using the number of output pulses per revolution, dividing ratio, or electronic gear ratio. (after multiplication by 4)</p> <p>To set a numerator of the electronic gear, select "A-phase/B-phase pulse electronic gear setting (_ _ 3 _)" of "Encoder output pulse setting selection" in [Pr. PC19].</p> <p>The maximum output frequency is 4.6 Mpulses/s (after multiplication by 4). Use this parameter within this range.</p> <p>Setting range: 1 to 4194304</p>	4000	P S T
			PA16	<p>Set a denominator of the electronic gear for the A/B-phase pulse output.</p> <p>To set a denominator of the electronic gear, select "A-phase/B-phase pulse electronic gear setting (_ _ 3 _)" of "Encoder output pulse setting selection" in [Pr. PC19].</p> <p>Setting range: 1 to 4194304</p>	1	

Part 2: Review on Replacement of MR-J3- _A_ with MR-J4- _A_

MR-J3- _A_				MR-J4- _A_				Control mode																																																																																																																																																																																													
No.	Name and function			Initial value	No.	Name and function			Initial value																																																																																																																																																																																												
PA19	Parameter write inhibit			000Bh	PA19	Parameter writing inhibit			00AAh	P S T																																																																																																																																																																																											
	[Pr. PA19] setting	Setting operation	Basic setting parameters [Pr. PA_ _]			Gain/Filter parameters [Pr. PB_ _]	Extension setting parameters [Pr. PC_ _]	I/O setting parameters [Pr. PD_ _]																																																																																																																																																																																													
	0000h	Reference	<input type="radio"/>																																																																																																																																																																																																		
		Writing	<input type="radio"/>																																																																																																																																																																																																		
	000Bh (initial value)	Reference	<input type="radio"/>	<input type="radio"/>	<input type="radio"/>																																																																																																																																																																																																
		Writing	<input type="radio"/>	<input type="radio"/>	<input type="radio"/>																																																																																																																																																																																																
	000Ch	Reference	<input type="radio"/>	<input type="radio"/>	<input type="radio"/>	<input type="radio"/>																																																																																																																																																																																															
		Writing	<input type="radio"/>	<input type="radio"/>	<input type="radio"/>	<input type="radio"/>																																																																																																																																																																																															
	100Bh	Reference	<input type="radio"/>																																																																																																																																																																																																		
		Writing	[Pr. PA19] only																																																																																																																																																																																																		
	100Ch	Reference	<input type="radio"/>	<input type="radio"/>	<input type="radio"/>																																																																																																																																																																																																
		Writing	[Pr. PA19] only																																																																																																																																																																																																		
				O: Enabled																																																																																																																																																																																																	
PA19	Parameter write inhibit			000Bh	PA19	Parameter writing inhibit			00AAh	P S T																																																																																																																																																																																											
	[Pr. PA19] setting	Setting operation	Basic setting parameters [Pr. PA_ _]			Gain/Filter parameters [Pr. PB_ _]	Extension setting parameters [Pr. PC_ _]	I/O setting parameters [Pr. PD_ _]																																																																																																																																																																																													
	0000h	Reference	<input type="radio"/>																																																																																																																																																																																																		
		Writing	<input type="radio"/>																																																																																																																																																																																																		
	000Bh (initial value)	Reference	<input type="radio"/>	<input type="radio"/>	<input type="radio"/>																																																																																																																																																																																																
		Writing	<input type="radio"/>	<input type="radio"/>	<input type="radio"/>																																																																																																																																																																																																
	000Ch	Reference	<input type="radio"/>	<input type="radio"/>	<input type="radio"/>	<input type="radio"/>																																																																																																																																																																																															
		Writing	<input type="radio"/>	<input type="radio"/>	<input type="radio"/>	<input type="radio"/>																																																																																																																																																																																															
	100Bh	Reference	<input type="radio"/>																																																																																																																																																																																																		
		Writing	[Pr. PA19] only																																																																																																																																																																																																		
	100Ch	Reference	<input type="radio"/>	<input type="radio"/>	<input type="radio"/>																																																																																																																																																																																																
		Writing	[Pr. PA19] only																																																																																																																																																																																																		
				O: Enabled																																																																																																																																																																																																	
				Table 2.4 [Pr. PA19] setting value and reading/writing range																																																																																																																																																																																																	
				<table border="1"> <thead> <tr> <th>PA19</th> <th>Setting operation</th> <th>PA</th> <th>PB</th> <th>PC</th> <th>PD</th> <th>PE</th> <th>PF</th> <th>PL</th> </tr> </thead> <tbody> <tr> <td>Other than below</td> <td>Reading</td> <td><input type="radio"/></td> <td></td> <td></td> <td></td> <td></td> <td></td> <td></td> </tr> <tr> <td></td> <td>Writing</td> <td><input type="radio"/></td> <td></td> <td></td> <td></td> <td></td> <td></td> <td></td> </tr> <tr> <td>000A</td> <td>Reading</td> <td>Only 19</td> <td></td> <td></td> <td></td> <td></td> <td></td> <td></td> </tr> <tr> <td></td> <td>Writing</td> <td>Only 19</td> <td></td> <td></td> <td></td> <td></td> <td></td> <td></td> </tr> <tr> <td>000B</td> <td>Reading</td> <td><input type="radio"/></td> <td><input type="radio"/></td> <td><input type="radio"/></td> <td><input type="radio"/></td> <td></td> <td></td> <td></td> </tr> <tr> <td></td> <td>Writing</td> <td><input type="radio"/></td> <td><input type="radio"/></td> <td><input type="radio"/></td> <td><input type="radio"/></td> <td></td> <td></td> <td></td> </tr> <tr> <td>000C</td> <td>Reading</td> <td><input type="radio"/></td> <td><input type="radio"/></td> <td><input type="radio"/></td> <td><input type="radio"/></td> <td><input type="radio"/></td> <td></td> <td></td> </tr> <tr> <td></td> <td>Writing</td> <td><input type="radio"/></td> <td><input type="radio"/></td> <td><input type="radio"/></td> <td><input type="radio"/></td> <td><input type="radio"/></td> <td></td> <td></td> </tr> <tr> <td>00AAh (initial value)</td> <td>Reading</td> <td><input type="radio"/></td> <td><input type="radio"/></td> <td><input type="radio"/></td> <td><input type="radio"/></td> <td><input type="radio"/></td> <td><input type="radio"/></td> <td></td> </tr> <tr> <td></td> <td>Writing</td> <td><input type="radio"/></td> <td><input type="radio"/></td> <td><input type="radio"/></td> <td><input type="radio"/></td> <td><input type="radio"/></td> <td><input type="radio"/></td> <td></td> </tr> <tr> <td>00AB</td> <td>Reading</td> <td><input type="radio"/></td> <td><input type="radio"/></td> <td><input type="radio"/></td> <td><input type="radio"/></td> <td><input type="radio"/></td> <td><input type="radio"/></td> <td><input type="radio"/></td> </tr> <tr> <td></td> <td>Writing</td> <td><input type="radio"/></td> <td><input type="radio"/></td> <td><input type="radio"/></td> <td><input type="radio"/></td> <td><input type="radio"/></td> <td><input type="radio"/></td> <td><input type="radio"/></td> </tr> <tr> <td>100B</td> <td>Reading</td> <td><input type="radio"/></td> <td></td> <td></td> <td></td> <td></td> <td></td> <td></td> </tr> <tr> <td></td> <td>Writing</td> <td>Only 19</td> <td></td> <td></td> <td></td> <td></td> <td></td> <td></td> </tr> <tr> <td>100C</td> <td>Reading</td> <td><input type="radio"/></td> <td><input type="radio"/></td> <td><input type="radio"/></td> <td><input type="radio"/></td> <td></td> <td></td> <td></td> </tr> <tr> <td></td> <td>Writing</td> <td>Only 19</td> <td><input type="radio"/></td> <td><input type="radio"/></td> <td><input type="radio"/></td> <td></td> <td></td> <td></td> </tr> <tr> <td>10AA</td> <td>Reading</td> <td><input type="radio"/></td> <td><input type="radio"/></td> <td><input type="radio"/></td> <td><input type="radio"/></td> <td><input type="radio"/></td> <td><input type="radio"/></td> <td></td> </tr> <tr> <td></td> <td>Writing</td> <td>Only 19</td> <td><input type="radio"/></td> <td><input type="radio"/></td> <td><input type="radio"/></td> <td><input type="radio"/></td> <td><input type="radio"/></td> <td></td> </tr> <tr> <td>10AB</td> <td>Reading</td> <td><input type="radio"/></td> <td><input type="radio"/></td> <td><input type="radio"/></td> <td><input type="radio"/></td> <td><input type="radio"/></td> <td><input type="radio"/></td> <td><input type="radio"/></td> </tr> <tr> <td></td> <td>Writing</td> <td>Only 19</td> <td><input type="radio"/></td> <td><input type="radio"/></td> <td><input type="radio"/></td> <td><input type="radio"/></td> <td><input type="radio"/></td> <td><input type="radio"/></td> </tr> </tbody> </table>				PA19	Setting operation	PA	PB	PC	PD	PE	PF	PL	Other than below	Reading	<input type="radio"/>								Writing	<input type="radio"/>							000A	Reading	Only 19								Writing	Only 19							000B	Reading	<input type="radio"/>	<input type="radio"/>	<input type="radio"/>	<input type="radio"/>					Writing	<input type="radio"/>	<input type="radio"/>	<input type="radio"/>	<input type="radio"/>				000C	Reading	<input type="radio"/>	<input type="radio"/>	<input type="radio"/>	<input type="radio"/>	<input type="radio"/>				Writing	<input type="radio"/>	<input type="radio"/>	<input type="radio"/>	<input type="radio"/>	<input type="radio"/>			00AAh (initial value)	Reading	<input type="radio"/>	<input type="radio"/>	<input type="radio"/>	<input type="radio"/>	<input type="radio"/>	<input type="radio"/>			Writing	<input type="radio"/>	<input type="radio"/>	<input type="radio"/>	<input type="radio"/>	<input type="radio"/>	<input type="radio"/>		00AB	Reading	<input type="radio"/>	<input type="radio"/>	<input type="radio"/>	<input type="radio"/>	<input type="radio"/>	<input type="radio"/>	<input type="radio"/>		Writing	<input type="radio"/>	<input type="radio"/>	<input type="radio"/>	<input type="radio"/>	<input type="radio"/>	<input type="radio"/>	<input type="radio"/>	100B	Reading	<input type="radio"/>								Writing	Only 19							100C	Reading	<input type="radio"/>	<input type="radio"/>	<input type="radio"/>	<input type="radio"/>					Writing	Only 19	<input type="radio"/>	<input type="radio"/>	<input type="radio"/>				10AA	Reading	<input type="radio"/>	<input type="radio"/>	<input type="radio"/>	<input type="radio"/>	<input type="radio"/>	<input type="radio"/>			Writing	Only 19	<input type="radio"/>	<input type="radio"/>	<input type="radio"/>	<input type="radio"/>	<input type="radio"/>		10AB	Reading	<input type="radio"/>	<input type="radio"/>	<input type="radio"/>	<input type="radio"/>	<input type="radio"/>	<input type="radio"/>	<input type="radio"/>		Writing	Only 19	<input type="radio"/>	<input type="radio"/>	<input type="radio"/>	<input type="radio"/>	<input type="radio"/>	<input type="radio"/>	
PA19	Setting operation	PA	PB	PC	PD	PE	PF	PL																																																																																																																																																																																													
Other than below	Reading	<input type="radio"/>																																																																																																																																																																																																			
	Writing	<input type="radio"/>																																																																																																																																																																																																			
000A	Reading	Only 19																																																																																																																																																																																																			
	Writing	Only 19																																																																																																																																																																																																			
000B	Reading	<input type="radio"/>	<input type="radio"/>	<input type="radio"/>	<input type="radio"/>																																																																																																																																																																																																
	Writing	<input type="radio"/>	<input type="radio"/>	<input type="radio"/>	<input type="radio"/>																																																																																																																																																																																																
000C	Reading	<input type="radio"/>	<input type="radio"/>	<input type="radio"/>	<input type="radio"/>	<input type="radio"/>																																																																																																																																																																																															
	Writing	<input type="radio"/>	<input type="radio"/>	<input type="radio"/>	<input type="radio"/>	<input type="radio"/>																																																																																																																																																																																															
00AAh (initial value)	Reading	<input type="radio"/>	<input type="radio"/>	<input type="radio"/>	<input type="radio"/>	<input type="radio"/>	<input type="radio"/>																																																																																																																																																																																														
	Writing	<input type="radio"/>	<input type="radio"/>	<input type="radio"/>	<input type="radio"/>	<input type="radio"/>	<input type="radio"/>																																																																																																																																																																																														
00AB	Reading	<input type="radio"/>	<input type="radio"/>	<input type="radio"/>	<input type="radio"/>	<input type="radio"/>	<input type="radio"/>	<input type="radio"/>																																																																																																																																																																																													
	Writing	<input type="radio"/>	<input type="radio"/>	<input type="radio"/>	<input type="radio"/>	<input type="radio"/>	<input type="radio"/>	<input type="radio"/>																																																																																																																																																																																													
100B	Reading	<input type="radio"/>																																																																																																																																																																																																			
	Writing	Only 19																																																																																																																																																																																																			
100C	Reading	<input type="radio"/>	<input type="radio"/>	<input type="radio"/>	<input type="radio"/>																																																																																																																																																																																																
	Writing	Only 19	<input type="radio"/>	<input type="radio"/>	<input type="radio"/>																																																																																																																																																																																																
10AA	Reading	<input type="radio"/>	<input type="radio"/>	<input type="radio"/>	<input type="radio"/>	<input type="radio"/>	<input type="radio"/>																																																																																																																																																																																														
	Writing	Only 19	<input type="radio"/>	<input type="radio"/>	<input type="radio"/>	<input type="radio"/>	<input type="radio"/>																																																																																																																																																																																														
10AB	Reading	<input type="radio"/>	<input type="radio"/>	<input type="radio"/>	<input type="radio"/>	<input type="radio"/>	<input type="radio"/>	<input type="radio"/>																																																																																																																																																																																													
	Writing	Only 19	<input type="radio"/>	<input type="radio"/>	<input type="radio"/>	<input type="radio"/>	<input type="radio"/>	<input type="radio"/>																																																																																																																																																																																													

PB01 Adaptive tuning mode (adaptive filter II)
 Select the setting method for filter tuning. Setting this parameter to "___ 1" (filter tuning mode) automatically changes the machine resonance suppression filter 1 [Pr. PB13], and notch shape selection 1 [Pr. PB14].

Response of mechanical system

Machine resonance point

Frequency

Notch depth

Notch frequency

Frequency

0 0 0 x:
 Adaptive tuning mode selection

Setting	Adaptive tuning mode	Automatically set parameter
0	Filter OFF	(Note)
1	Filter tuning mode	[Pr. PB13] [Pr. PB14]
2	Manual mode	

Note. [Pr. PB13] and [Pr. PB14] are fixed to the initial values.

When this parameter is set to "___ 1", the tuning is completed after positioning operation is done the predetermined number or times for the predetermined period of time, and the setting changes to "___ 2". When the adaptive tuning is not necessary, the setting changes to "___ 0". When this parameter is set to "___ 0", the initial values are set to the machine resonance suppression filter 1 and notch shape selection 1. However, this does not occur when the servo off.

PB01 Same as MR-J3

Adaptive tuning mode (adaptive filter II)
 ___ x:
 Filter tuning mode selection
 Set the adaptive tuning.
 Select the adjustment mode of the machine resonance suppression filter 1.
 0: Disabled
 1: Automatic setting (Do not use this in the torque control mode.)
 2: Manual setting

___ x _:
 For manufacturer setting

_ x _ _:
 For manufacturer setting

x _ _ _:
 Tuning accuracy selection
 0: Standard
 1: High accuracy
 The frequency is estimated more accurately in the high accuracy mode compared to the standard mode. However, the tuning sound may be larger in the high accuracy mode.
 This digit is available with servo amplifier with software version C5 or later.

0000h

P
S
T

0h

0h

0h

P
S
T

Part 2: Review on Replacement of MR-J3- _A_ with MR-J4- _A_

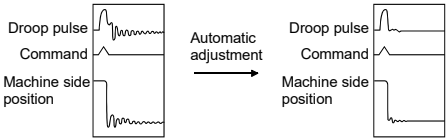
MR-J3- _A_			MR-J4- _A_															
No.	Name and function	Initial value	No.	Name and function	Initial value	Control mode												
PB02	<p>Vibration suppression control tuning mode (advanced vibration suppression control)</p> <p>The vibration suppression is valid when the [Pr. PA08] (auto tuning mode) setting is "___2" or "___3".</p> <p>When [Pr. PA08] is "___1", vibration suppression is always invalid.</p> <p>Select the setting method for vibration suppression control tuning. Setting this parameter to "___1" (vibration suppression control tuning mode) automatically changes the vibration suppression control - vibration frequency([Pr. PB19]) and vibration suppression control - resonance frequency([Pr. PB20]) after positioning is done the predetermined number of times.</p>  <p>0 0 0 x: Vibration suppression control tuning mode</p> <table border="1" data-bbox="236 981 673 1191"> <thead> <tr> <th>Setting</th> <th>Vibration suppression control tuning mode</th> <th>Automatically set parameter</th> </tr> </thead> <tbody> <tr> <td>0</td> <td>Vibration suppression control OFF</td> <td>(Note)</td> </tr> <tr> <td>1</td> <td>Vibration suppression control tuning mode (Advanced vibration suppression control)</td> <td>[Pr. PB19] [Pr. PB20]</td> </tr> <tr> <td>2</td> <td>Manual mode</td> <td></td> </tr> </tbody> </table> <p>Note. [Pr. PB19] and [Pr. PB20] are fixed to the initial values.</p> <p>When this parameter is set to "___1", the tuning is completed after positioning operation is done the predetermined number or times for the predetermined period of time, and the setting changes to "___2". When the vibration suppression control tuning is not necessary, the setting changes to "___0". When this parameter is set to "___0", the initial values are set to the vibration suppression control - vibration frequency and vibration suppression control - resonance frequency. However, this does not occur when the servo off.</p>	Setting	Vibration suppression control tuning mode	Automatically set parameter	0	Vibration suppression control OFF	(Note)	1	Vibration suppression control tuning mode (Advanced vibration suppression control)	[Pr. PB19] [Pr. PB20]	2	Manual mode		0000h	PB02	<p>Vibration suppression control tuning mode (advanced vibration suppression control II)</p> <p>___x: Vibration suppression control 1 tuning mode selection</p> <p>Select the tuning mode of the vibration suppression control 1.</p> <p>0: Disabled 1: Automatic setting 2: Manual setting</p> <p>__x__: Vibration suppression control 2 tuning mode selection</p> <p>Select the tuning mode of the vibration suppression control 2. To enable the setting of this digit, set "Vibration suppression mode selection" to "3 inertia mode (___1)" in [Pr. PA24].</p> <p>0: Disabled 1: Automatic setting 2: Manual setting</p> <p>__x__: For manufacturer setting</p> <p>x ___: For manufacturer setting</p>	0000h	P
Setting	Vibration suppression control tuning mode	Automatically set parameter																
0	Vibration suppression control OFF	(Note)																
1	Vibration suppression control tuning mode (Advanced vibration suppression control)	[Pr. PB19] [Pr. PB20]																
2	Manual mode																	

Part 2: Review on Replacement of MR-J3- _A_ with MR-J4- _A_

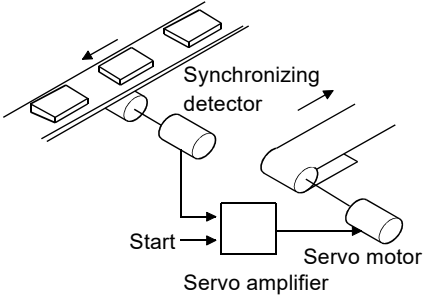
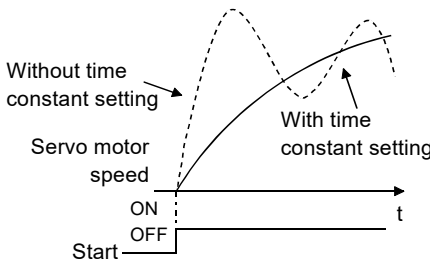
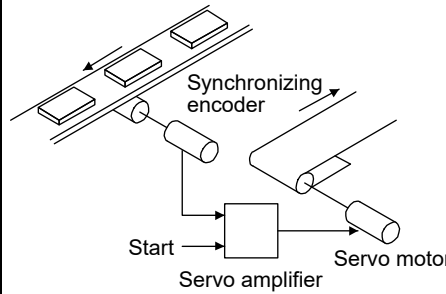
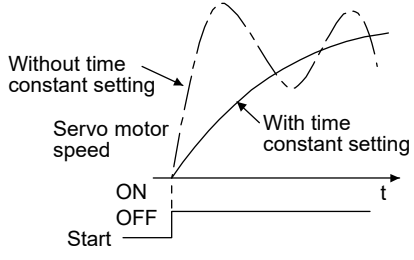
MR-J3- _A_			MR-J4- _A_			
No.	Name and function	Initial value	No.	Name and function	Initial value	Control mode
PB03	<p>Position command acceleration/deceleration time constant (position smoothing)</p> <p>Used to set the time constant of a low-pass filter in response to the position command.</p> <p>You can use [Pr. PB25] to choose the primary delay or linear acceleration/deceleration control system.</p> <p>When you choose linear acceleration/deceleration, the setting range is 0 to 10 ms. Setting of longer than 10 ms is recognized as 10 ms.</p> <div style="border: 1px solid black; padding: 5px; margin: 10px 0;"> <p>POINT</p> <ul style="list-style-type: none"> When you have chosen linear acceleration/deceleration, do not select control selection ([Pr. PA01]) and restart after instantaneous power failure ([Pr. PC22]). Doing so will cause the servo motor to make a sudden stop at the time of position control switching or restart. </div> <p>(Example) When a command is given from a synchronizing detector, synchronous operation can be started smoothly if started during line operation.</p>  	0	PB03	<p>Same as MR-J3</p> <p>Position command acceleration/deceleration time constant (position smoothing)</p> <p>Set the constant of a primary delay to the position command.</p> <p>You can select a control method from "Primary delay" or "Linear acceleration/deceleration" in [Pr. PB25 Function selection B-1]. When the linear acceleration/deceleration is selected, the setting range is 0 ms to 10 ms. Setting of longer than 10 ms will be recognized as 10 ms.</p> <p>When the linear acceleration/deceleration is selected, do not set the "Control mode selection" ([Pr. PA01]) to the setting other than "___0". Doing so will cause the servo motor to make a sudden stop at the time of position control mode switching.</p> <p>(Example) When a command is given from a synchronizing encoder, synchronous operation will start smoothly even if it starts during line operation.</p>   <p>Setting range: 0 to 65535</p>	0	P
PB04	<p>Feed forward gain</p> <p>Set the feed forward gain. When the setting is 100%, the droop pulses during operation at constant speed are nearly zero. However, sudden acceleration/deceleration will increase the overshoot. As a guideline, when the feed forward gain setting is 100%, set 1 s or longer as the acceleration time constant up to the rated speed.</p>	0	PB04	<p>Same setting as MR-J3</p> <p>Feed forward gain</p> <p>Set the feed forward gain.</p> <p>When the setting is 100%, the droop pulses during operation at constant speed are nearly zero. When the super trace control is enabled, constant speed and uniform acceleration/deceleration droop pulses will be almost 0. However, sudden acceleration/deceleration will increase the overshoot. As a guideline, when the feed forward gain setting is 100%, set 1 s or more as the acceleration time constant up to the rated speed.</p> <p>Setting range: 0 to 100</p>	0	P

Part 2: Review on Replacement of MR-J3- _A_ with MR-J4- _A_

MR-J3- _A_			MR-J4- _A_			Control mode										
No.	Name and function	Initial value	No.	Name and function	Initial value											
PB06	<p>Ratio of load inertia moment to servo motor inertia moment</p> <p>Used to set the ratio of the load inertia moment to the servo motor shaft inertia moment. When auto tuning mode 1 and interpolation mode is selected, the result of auto tuning is automatically used. In this case, it varies between 0 and 100.0.</p>	7.0	PB06	<p>Load to motor inertia ratio</p> <p>Set the load to motor inertia ratio.</p> <p>The setting of the parameter will be the automatic setting or manual setting depending on the [Pr. PA08] setting. Refer to the following table for details. When the parameter is automatic setting, the value will vary between 0.00 and 100.00.</p> <table border="1"> <thead> <tr> <th>Pr. PA08</th> <th>This parameter</th> </tr> </thead> <tbody> <tr> <td>___ 0 (2 gain adjustment mode 1 (interpolation mode))</td> <td rowspan="2">Automatic setting</td> </tr> <tr> <td>___ 1 (Auto tuning mode 1)</td> </tr> <tr> <td>___ 2 (Auto tuning mode 2)</td> <td rowspan="2">Manual setting</td> </tr> <tr> <td>___ 3 (Manual mode)</td> </tr> <tr> <td>___ 4 (2 gain adjustment mode 2)</td> <td></td> </tr> </tbody> </table> <p>Setting range: 0.00 to 300.00</p>	Pr. PA08	This parameter	___ 0 (2 gain adjustment mode 1 (interpolation mode))	Automatic setting	___ 1 (Auto tuning mode 1)	___ 2 (Auto tuning mode 2)	Manual setting	___ 3 (Manual mode)	___ 4 (2 gain adjustment mode 2)		7.00	P S
Pr. PA08	This parameter															
___ 0 (2 gain adjustment mode 1 (interpolation mode))	Automatic setting															
___ 1 (Auto tuning mode 1)																
___ 2 (Auto tuning mode 2)	Manual setting															
___ 3 (Manual mode)																
___ 4 (2 gain adjustment mode 2)																
PB07	<p>Model loop gain</p> <p>Set the response gain up to the target position. Increase the gain to improve track ability in response to the command. When auto turning mode 1 - 2 is selected, the result of auto turning is automatically used.</p>	24	PB07	<p>Same setting as MR-J3</p> <p>Model loop gain</p> <p>Set the response gain up to the target position. Increasing the setting value will also increase the response level to the position command but will be liable to generate vibration and noise. The setting of the parameter will be the automatic setting or manual setting depending on the [Pr. PA08] setting.</p> <table border="1"> <thead> <tr> <th>Pr. PA08</th> <th>This parameter</th> </tr> </thead> <tbody> <tr> <td>___ 0 (2 gain adjustment mode 1 (interpolation mode))</td> <td>Manual setting</td> </tr> <tr> <td>___ 1 (Auto tuning mode 1)</td> <td rowspan="2">Automatic setting</td> </tr> <tr> <td>___ 2 (Auto tuning mode 2)</td> </tr> <tr> <td>___ 3 (Manual mode)</td> <td rowspan="2">Manual setting</td> </tr> <tr> <td>___ 4 (2 gain adjustment mode 2)</td> </tr> </tbody> </table> <p>Setting range: 1.0 to 2000.0</p>	Pr. PA08	This parameter	___ 0 (2 gain adjustment mode 1 (interpolation mode))	Manual setting	___ 1 (Auto tuning mode 1)	Automatic setting	___ 2 (Auto tuning mode 2)	___ 3 (Manual mode)	Manual setting	___ 4 (2 gain adjustment mode 2)	15.0	P
Pr. PA08	This parameter															
___ 0 (2 gain adjustment mode 1 (interpolation mode))	Manual setting															
___ 1 (Auto tuning mode 1)	Automatic setting															
___ 2 (Auto tuning mode 2)																
___ 3 (Manual mode)	Manual setting															
___ 4 (2 gain adjustment mode 2)																
PB08	<p>Position loop gain</p> <p>Used to set the gain of the position loop. Set this parameter to increase the position response to level load disturbance. Higher setting increases the response level but is liable to generate vibration and/or noise. When auto tuning mode 1 - 2 and interpolation mode is selected, the result of auto tuning is automatically used.</p>	37	PB08	<p>Same setting as MR-J3</p> <p>Position loop gain</p> <p>Set the gain of the position loop. Set this parameter to increase the position response to level load disturbance. Increasing the setting value will also increase the response level to the load disturbance but will be liable to generate vibration and noise. The setting of the parameter will be the automatic setting or manual setting depending on the [Pr. PA08] setting. Refer to the following table for details.</p> <table border="1"> <thead> <tr> <th>Pr. PA08</th> <th>This parameter</th> </tr> </thead> <tbody> <tr> <td>___ 0 (2 gain adjustment mode 1 (interpolation mode))</td> <td rowspan="2">Automatic setting</td> </tr> <tr> <td>___ 1 (Auto tuning mode 1)</td> </tr> <tr> <td>___ 2 (Auto tuning mode 2)</td> <td rowspan="2">Manual setting</td> </tr> <tr> <td>___ 3 (Manual mode)</td> </tr> <tr> <td>___ 4 (2 gain adjustment mode 2)</td> <td>Automatic setting</td> </tr> </tbody> </table> <p>Setting range: 1.0 to 2000.0</p>	Pr. PA08	This parameter	___ 0 (2 gain adjustment mode 1 (interpolation mode))	Automatic setting	___ 1 (Auto tuning mode 1)	___ 2 (Auto tuning mode 2)	Manual setting	___ 3 (Manual mode)	___ 4 (2 gain adjustment mode 2)	Automatic setting	37.0	P
Pr. PA08	This parameter															
___ 0 (2 gain adjustment mode 1 (interpolation mode))	Automatic setting															
___ 1 (Auto tuning mode 1)																
___ 2 (Auto tuning mode 2)	Manual setting															
___ 3 (Manual mode)																
___ 4 (2 gain adjustment mode 2)	Automatic setting															

Part 2: Review on Replacement of MR-J3- _A_ with MR-J4- _A_

MR-J3- _A_			MR-J4- _A_			Control mode
No.	Name and function	Initial value	No.	Name and function	Initial value	
PB09	<p>Speed loop gain</p> <p>Used to set the gain of the speed loop. Set this parameter when vibration occurs on machines of low rigidity or large backlash. Higher setting increases the response level but is liable to generate vibration and/or noise. When auto tuning mode 1 • 2, manual mode and interpolation mode is selected, the result of auto tuning is automatically used.</p> <p>Note. The setting range of 50000 applies to the servo amplifier whose software version is A3 or later. The setting range of the servo amplifier whose software version is older than A3 is 20 to 20000. When the software version of Setup software (SETUP221E) is A3 or earlier, 20001 or more cannot be set. Use the display/operation section of the servo amplifier to set 20001 or more.</p>	823	PB09	<p>Same setting as MR-J3</p> <p>Speed loop gain</p> <p>Set the gain of the speed loop. Set this parameter when vibration occurs on machines of low rigidity or large backlash. Increasing the setting value will also increase the response level but will be liable to generate vibration and noise.</p> <p>The setting of the parameter will be the automatic setting or manual setting depending on the [Pr. PA08] setting. Refer to the table of [Pr. PB08] for details.</p> <p>Setting range: 20 to 65535</p>	823	P S
PB10	<p>Speed integral compensation</p> <p>Used to set the integral time constant of the speed loop. Lower setting increases the response level but is liable to generate vibration and/or noise. When auto tuning mode 1 • 2 and interpolation mode is selected, the result of auto tuning is automatically used.</p>	33.7	PB10	<p>Same setting as MR-J3</p> <p>Speed integral compensation</p> <p>Set the integral time constant of the speed loop. Decreasing the setting value will increase the response level but will be liable to generate vibration and noise.</p> <p>The setting of the parameter will be the automatic setting or manual setting depending on the [Pr. PA08] setting. Refer to the table of [Pr. PB08] for details.</p> <p>Setting range: 0.1 to 1000.0</p>	33.7	P S
PB11	<p>Speed differential compensation</p> <p>Used to set the differential compensation. Made valid when the proportion control (PC) is switched on.</p>	980	PB11	<p>Speed differential compensation</p> <p>Set the differential compensation. To enable the setting value, turn on PC (proportional control).</p> <p>Setting range: 0 to 1000</p>	980	P S
PB12	For manufacturer setting	0	PB12	<p>Overshoot amount compensation</p> <p>Set a dynamic friction torque friction torque in percentage to the servo motor rated speed. When the response level is low or when the torque is limited, the efficiency of the parameter may be lower.</p> <p>Setting range: 0 to 100</p>	0	P
PB13	<p>Machine resonance suppression filter 1</p> <p>Set the notch frequency of the machine resonance suppression filter 1.</p> <p>Setting [Pr. PB01] (Adaptive tuning mode (Adaptive filter II)) to "___1" automatically changes this parameter.</p> <p>When the [Pr. PB01] setting is "___0", the setting of this parameter is ignored.</p>	4500	PB13	<p>Machine resonance suppression filter 1</p> <p>Set the notch frequency of the machine resonance suppression filter 1.</p> <p>When "Filter tuning mode selection" is set to "Automatic setting (___1)" in [Pr. PB01], this parameter will be adjusted automatically by adaptive tuning.</p> <p>When "Filter tuning mode selection" is set to "Manual setting (___2)" in [Pr. PB01], the setting value will be enabled.</p> <p>Setting range: 10 to 4500</p>	4500	P S T

Part 2: Review on Replacement of MR-J3- _A_ with MR-J4- _A_

MR-J3- _A_			MR-J4- _A_			Control mode				
No.	Name and function	Initial value	No.	Name and function	Initial value					
PB14	Notch shape selection 1 Used to selection the machine resonance suppression filter 1. Setting [Pr. PB01] (Adaptive tuning mode (Adaptive filter II)) to "___1" automatically changes this parameter. When the [Pr. PB01] setting is "___0", the setting of this parameter is ignored.	0000h	PB14	Notch shape selection 1 Set the shape of the machine resonance suppression filter 1. When "Filter tuning mode selection" is set to "Automatic setting (___1)" in [Pr. PB01], this parameter will be adjusted automatically by adaptive tuning. Set manually for the manual setting.						
	0 0 x 0: Notch depth selection 0: -40 dB 1: -14 dB 2: -8 dB 3: -4 dB			___ x: For manufacturer setting			0h			
	0 x 0 0: Notch width selection 0: $\alpha = 2$ 1: $\alpha = 3$ 2: $\alpha = 4$ 3: $\alpha = 5$			__ x _: Notch depth selection 0: -40 dB 1: -14 dB 2: -8 dB 3: -4 dB			0h	P S T		
				_ x _ _: Notch width selection 0: $\alpha = 2$ 1: $\alpha = 3$ 2: $\alpha = 4$ 3: $\alpha = 5$			0h	P S T		
PB15	Machine resonance suppression filter 2 Set the notch frequency of the machine resonance suppression filter 2. Set [Pr. PB16] (notch shape selection 2) to "___1" to make this parameter valid.	4500	PB15	Same as MR-J3	4500	P S T				
				Machine resonance suppression filter 2 Set the notch frequency of the machine resonance suppression filter 2. To enable the setting value, set "Machine resonance suppression filter 2 selection" to "Enabled (___1)" in [Pr. PB16]. Setting range: 10 to 4500						
PB16	Notch shape selection 2 Select the shape of the machine resonance suppression filter 2.	0000h	PB16	Same as MR-J3						
	0 0 0 x: Machine resonance suppression filter 2 selection 0: Invalid 1: Valid			Notch shape selection 2 Set the shape of the machine resonance suppression filter 2.						
	0 0 x 0: Notch depth selection 0: -40 dB 1: -14 dB 2: -8 dB 3: -4 dB			___ x: Machine resonance suppression filter 2 selection 0: Disabled 1: Enabled					0h	P S T
	0 x 0 0: Notch width selection 0: $\alpha = 2$ 1: $\alpha = 3$ 2: $\alpha = 4$ 3: $\alpha = 5$			__ x _: Notch depth selection 0: -40 dB 1: -14 dB 2: -8 dB 3: -4 dB					0h	P S T
	_ x _ _: Notch width selection 0: $\alpha = 2$ 1: $\alpha = 3$ 2: $\alpha = 4$ 3: $\alpha = 5$	0h	P S T							
				x _ _ _: For manufacturer setting	0h					

Part 2: Review on Replacement of MR-J3- A_ with MR-J4- A_

MR-J3- A_			MR-J4- A_			Control mode																																																																			
No.	Name and function	Initial value	No.	Name and function	Initial value																																																																				
PB17	Automatic setting parameter The value of this parameter is set according to a set value of [Pr. PB06] (Ratio of load inertia moment to servo motor inertia moment).		PB17	Shaft resonance suppression filter Set the shaft resonance suppression filter. This is used to suppress a low-frequency machine vibration. When "Shaft resonance suppression filter selection" is "Automatic setting (_ _ _ 0)" in [Pr. PB23], the value will be calculated automatically from the servo motor you use and load to motor inertia ratio. Set manually for "Manual setting (_ _ _ 1)". When "Shaft resonance suppression filter selection" is "Disabled (_ _ _ 2)" in [Pr. PB23], the setting value of this parameter is disabled. When "Machine resonance suppression filter 4 selection" is "Enabled (_ _ _ 1)" in [Pr. PB49], the shaft resonance suppression filter is not available.		P S T																																																																			
			__ x x: Shaft resonance suppression filter setting frequency selection Refer to table 2.5 for settings. Set the value closest to the frequency you need.	00h	P S T																																																																				
			_ x _ : Notch depth selection 0: -40 dB 1: -14 dB 2: -8 dB 3: -4 dB	0h	P S T																																																																				
			x _ _ : For manufacturer setting	0h																																																																					
			Table 2.5 Shaft resonance suppression filter setting frequency selection																																																																						
				<table border="1"> <thead> <tr> <th>Setting value</th> <th>Frequency [Hz]</th> <th>Setting value</th> <th>Frequency [Hz]</th> </tr> </thead> <tbody> <tr><td>_ _ 0 0</td><td>Disabled</td><td>_ _ 1 0</td><td>562</td></tr> <tr><td>_ _ 0 1</td><td>Disabled</td><td>_ _ 1 1</td><td>529</td></tr> <tr><td>_ _ 0 2</td><td>4500</td><td>_ _ 1 2</td><td>500</td></tr> <tr><td>_ _ 0 3</td><td>3000</td><td>_ _ 1 3</td><td>473</td></tr> <tr><td>_ _ 0 4</td><td>2250</td><td>_ _ 1 4</td><td>450</td></tr> <tr><td>_ _ 0 5</td><td>1800</td><td>_ _ 1 5</td><td>428</td></tr> <tr><td>_ _ 0 6</td><td>1500</td><td>_ _ 1 6</td><td>409</td></tr> <tr><td>_ _ 0 7</td><td>1285</td><td>_ _ 1 7</td><td>391</td></tr> <tr><td>_ _ 0 8</td><td>1125</td><td>_ _ 1 8</td><td>375</td></tr> <tr><td>_ _ 0 9</td><td>1000</td><td>_ _ 1 9</td><td>360</td></tr> <tr><td>_ _ 0 A</td><td>900</td><td>_ _ 1 A</td><td>346</td></tr> <tr><td>_ _ 0 B</td><td>818</td><td>_ _ 1 B</td><td>333</td></tr> <tr><td>_ _ 0 C</td><td>750</td><td>_ _ 1 C</td><td>321</td></tr> <tr><td>_ _ 0 D</td><td>692</td><td>_ _ 1 D</td><td>310</td></tr> <tr><td>_ _ 0 E</td><td>642</td><td>_ _ 1 E</td><td>300</td></tr> <tr><td>_ _ 0 F</td><td>600</td><td>_ _ 1 F</td><td>290</td></tr> </tbody> </table>	Setting value	Frequency [Hz]	Setting value	Frequency [Hz]	_ _ 0 0	Disabled	_ _ 1 0	562	_ _ 0 1	Disabled	_ _ 1 1	529	_ _ 0 2	4500	_ _ 1 2	500	_ _ 0 3	3000	_ _ 1 3	473	_ _ 0 4	2250	_ _ 1 4	450	_ _ 0 5	1800	_ _ 1 5	428	_ _ 0 6	1500	_ _ 1 6	409	_ _ 0 7	1285	_ _ 1 7	391	_ _ 0 8	1125	_ _ 1 8	375	_ _ 0 9	1000	_ _ 1 9	360	_ _ 0 A	900	_ _ 1 A	346	_ _ 0 B	818	_ _ 1 B	333	_ _ 0 C	750	_ _ 1 C	321	_ _ 0 D	692	_ _ 1 D	310	_ _ 0 E	642	_ _ 1 E	300	_ _ 0 F	600	_ _ 1 F	290	
Setting value	Frequency [Hz]	Setting value	Frequency [Hz]																																																																						
_ _ 0 0	Disabled	_ _ 1 0	562																																																																						
_ _ 0 1	Disabled	_ _ 1 1	529																																																																						
_ _ 0 2	4500	_ _ 1 2	500																																																																						
_ _ 0 3	3000	_ _ 1 3	473																																																																						
_ _ 0 4	2250	_ _ 1 4	450																																																																						
_ _ 0 5	1800	_ _ 1 5	428																																																																						
_ _ 0 6	1500	_ _ 1 6	409																																																																						
_ _ 0 7	1285	_ _ 1 7	391																																																																						
_ _ 0 8	1125	_ _ 1 8	375																																																																						
_ _ 0 9	1000	_ _ 1 9	360																																																																						
_ _ 0 A	900	_ _ 1 A	346																																																																						
_ _ 0 B	818	_ _ 1 B	333																																																																						
_ _ 0 C	750	_ _ 1 C	321																																																																						
_ _ 0 D	692	_ _ 1 D	310																																																																						
_ _ 0 E	642	_ _ 1 E	300																																																																						
_ _ 0 F	600	_ _ 1 F	290																																																																						

Part 2: Review on Replacement of MR-J3- _A_ with MR-J4- _A_

MR-J3- _A_			MR-J4- _A_			Control mode								
No.	Name and function	Initial value	No.	Name and function	Initial value									
PB18	<p>Low-pass filter setting</p> <p>Set the low-pass filter.</p> <p>Setting [Pr. PB23] (low-pass filter selection) to " __ 0 _ " automatically changes this parameter.</p> <p>When [Pr. PB23] is set to " __ 1 _ ", this parameter can be set manually.</p>	3141	PB18	<p>Same as MR-J3</p> <p>Low-pass filter setting</p> <p>Set the low-pass filter.</p> <p>The following shows a relation of a required parameter to this parameter.</p> <table border="1" data-bbox="868 499 1257 685"> <thead> <tr> <th>[Pr. PB23]</th> <th>[Pr. PB18]</th> </tr> </thead> <tbody> <tr> <td> __ 0 _ (Initial value)</td> <td>Automatic setting</td> </tr> <tr> <td> __ 1 _</td> <td>Setting value enabled</td> </tr> <tr> <td> __ 2 _</td> <td>Setting value disabled</td> </tr> </tbody> </table> <p>Setting is not necessary because this parameter is automatically set.</p>	[Pr. PB23]	[Pr. PB18]	__ 0 _ (Initial value)	Automatic setting	__ 1 _	Setting value enabled	__ 2 _	Setting value disabled	3141	P S
[Pr. PB23]	[Pr. PB18]													
__ 0 _ (Initial value)	Automatic setting													
__ 1 _	Setting value enabled													
__ 2 _	Setting value disabled													
PB19	<p>Vibration suppression control vibration frequency setting</p> <p>Set the vibration frequency for vibration suppression control to suppress low-frequency machine vibration, such as enclosure vibration.</p> <p>Setting [Pr. PB02] (vibration suppression control tuning mode) to " ___ 1 " automatically changes this parameter. When [Pr. PB02] is set to " ___ 2 ", this parameter can be set manually.</p>	100.0	PB19	<p>Same as MR-J3</p> <p>Vibration suppression control 1 - Vibration frequency</p> <p>Set the vibration frequency for vibration suppression control 1 to suppress low-frequency machine vibration.</p> <p>When "Vibration suppression control 1 tuning mode selection" is set to "Automatic setting (___ 1)" in [Pr. PB02], this parameter will be set automatically. Set manually for "Manual setting (___ 2)".</p> <p>The setting range of this parameter varies, depending on the value in [Pr. PB07]. If a value out of the range is set, the vibration suppression control will be disabled. Refer to "MR-J4- _A_ (-RJ)/MR-J4-03A6(-RJ) Servo Amplifier Instruction Manual".</p> <p>Setting range: 0.1 to 300.0</p>	100.0	P								
PB20	<p>Vibration suppression control resonance frequency setting</p> <p>Set the resonance frequency for vibration suppression control to suppress low-frequency machine vibration, such as enclosure vibration.</p> <p>Setting [Pr. PB02] (vibration suppression control tuning mode) to " ___ 1 " automatically changes this parameter. When [Pr. PB02] is set to " ___ 2 ", this parameter can be set manually.</p>	PB20	PB20	<p>Same as MR-J3</p> <p>Vibration suppression control 1 - Resonance frequency</p> <p>Set the resonance frequency for vibration suppression control 1 to suppress low-frequency machine vibration.</p> <p>When "Vibration suppression control 1 tuning mode selection" is set to "Automatic setting (___ 1)" in [Pr. PB02], this parameter will be set automatically. Set manually for "Manual setting (___ 2)".</p> <p>The setting range of this parameter varies, depending on the value in [Pr. PB07]. If a value out of the range is set, the vibration suppression control will be disabled. Refer to "MR-J4- _A_ (-RJ)/MR-J4-03A6(-RJ) Servo Amplifier Instruction Manual".</p> <p>Setting range: 0.1 to 300.0</p>	100.0	P								
PB21	<p>For manufacturer setting</p> <p>Do not change this value by any means.</p>	0.00	PB21	<p>Vibration suppression control 1 - Vibration frequency damping</p> <p>Set a damping of the vibration frequency for vibration suppression control 1 to suppress low-frequency machine vibration.</p> <p>When "Vibration suppression control 1 tuning mode selection" is set to "Automatic setting (___ 1)" in [Pr. PB02], this parameter will be set automatically. Set manually for "Manual setting (___ 2)".</p> <p>Refer to " MR-J4- _A_ (-RJ)/MR-J4-03A6(-RJ) Servo Amplifier Instruction Manual".</p> <p>Setting range: 0.00 to 0.30</p>	0.00	P								

Part 2: Review on Replacement of MR-J3- _A_ with MR-J4- _A_

MR-J3- _A_			MR-J4- _A_			
No.	Name and function	Initial value	No.	Name and function	Initial value	Control mode
PB22	For manufacturer setting Do not change this value by any means.	0.00	PB22	Vibration suppression control 1 - Resonance frequency damping Set a damping of the resonance frequency for vibration suppression control 1 to suppress low-frequency machine vibration. When "Vibration suppression control 1 tuning mode selection" is set to "Automatic setting (_ _ _ 1)" in [Pr. PB02], this parameter will be set automatically. Set manually for "Manual setting (_ _ _ 2)". Refer to "MR-J4- _A_ (-RJ)/MR-J4-03A6(-RJ) Servo Amplifier Instruction Manual". Setting range: 0.00 to 0.30	0.00	P
PB23	Low-pass filter selection Select the low-pass filter. 0 0 x 0: Low-pass filter selection 0: Automatic setting 1: Manual setting ([Pr. PB18] setting) When automatic setting has been selected, select the filter that has the band width close to the one calculated with $\frac{VG2 \cdot 10}{1 + GD2} \text{ [rad/s]}$	0000h	PB23	Same setting as MR-J3	0h	P S T
				Low-pass filter selection Shaft resonance suppression filter selection _ _ _ x: Select the shaft resonance suppression filter. 0: Automatic setting 1: Manual setting 2: Disabled When "Machine resonance suppression filter 4 selection" is set to "Enabled (_ _ _ 1)" in [Pr. PB49], the shaft resonance suppression filter is not available.	0h	
				_ _ x _: Low-pass filter selection Select the low-pass filter. 0: Automatic setting 1: Manual setting 2: Disabled	0h	
				_ x _ _: For manufacturer setting	0h	
				x _ _ _: For manufacturer setting	0h	
PB24	Slight vibration suppression control selection Select the slight vibration suppression control. When [Pr. PA08] (auto tuning mode) is set to " _ _ _ 3", the slight vibration suppression control is made valid. 0 0 0 x: Slight vibration suppression control selection 0: Invalid 1: Valid	0000h	PB24	Same as MR-J3	0h	P
				Slight vibration suppression control Slight vibration suppression control selection _ _ _ x: Select the slight vibration suppression control. 0: Disabled 1: Enabled To enable the slight vibration suppression control, set "Gain adjustment mode selection" to "Manual mode (_ _ _ 3)" in [Pr. PA08]. Slight vibration suppression control cannot be used in the speed control mode.	0h	
				_ _ x _: For manufacturer setting	0h	
				_ x _ _: For manufacturer setting	0h	
				x _ _ _: For manufacturer setting	0h	

Part 2: Review on Replacement of MR-J3- _A_ with MR-J4- _A_

MR-J3- _A_			MR-J4- _A_					
No.	Name and function	Initial value	No.	Name and function	Initial value	Control mode		
PB25	<p>Function selection B-1 Select the control systems for position command acceleration/deceleration time constant ([Pr. PB03]).</p> <p>0 0 x 0: Control of position command acceleration/ deceleration time constant</p> <p>0: Primary delay 1: Linear acceleration/deceleration</p> <p>When linear acceleration/deceleration is selected, do not execute control switching after instantaneous power failure. The servo motor will make a sudden stop during the control switching or automatic restart.</p>	0000h	PB25	<p>Function selection B-1 ___x: Model adaptive control selection 0: Enabled (model adaptive control) 2: Disabled (PID control) This digit is supported with software version B4 or later.</p>	0h	P		
				<p>__x_: Position acceleration/deceleration filter type selection Select the position acceleration/deceleration filter type. 0: Primary delay 1: Linear acceleration/deceleration When you select "Linear acceleration/deceleration", do not switch the control mode. Doing so will cause the servo motor to make a sudden stop at the time of control mode switching.</p>			0h	P
				<p>_x_: For manufacturer setting</p>			0h	
				<p>x_: For manufacturer setting</p>			0h	
PB26	<p>Gain changing selection Select the gain changing condition.</p> <p>0 0 0 x: Gain changing selection Under any of the following conditions, the gains change on the basis of the [Pr. PB29] to [Pr. PB34] settings</p> <p>0: Invalid 1: Input device (Gain changing (CDP)) 2: Command frequency ([Pr. PB27] setting) 3: Droop pulse ([Pr. PB27] setting) 4: Servo motor speed ([Pr. PB27] setting)</p> <p>__x_: Gain changing condition 0: Valid when the input device (gain changing (CDP)) is ON, or valid when the value is equal to or larger than the value set in [Pr. PB27] 1: Valid when the input device (gain changing (CDP)) is OFF, or valid when the value is equal to or smaller than the value set in [Pr. PB27]</p> <p>_x_: For manufacturer setting Do not change this value by any means.</p> <p>x_: For manufacturer setting Do not change this value by any means.</p>	0h	PB26	<p>Gain switching function Select the gain switching condition. Set conditions to enable the gain switching values set in [Pr. PB29] to [Pr. PB36] and [Pr. PB56] to [Pr. PB60].</p>	0h	P S		
				<p>___x: Gain switching selection 0: Disabled 1: Input device (gain switching (CDP)) 2: Command frequency 3: Droop pulses 4: Servo motor speed</p>				
				<p>__x_: Gain switching condition selection 0: Gain after switching is enabled with gain switching condition or more 1: Gain after switching is enabled with gain switching condition or less</p>				
				<p>_x_: Gain switching time constant disabling condition selection 0: Switching time constant enabled 1: Switching time constant disabled 2: Return time constant disabled This digit is used by servo amplifier with software version B4 or later.</p>				
				<p>x_: For manufacturer setting</p>			0h	
PB27	<p>Gain changing condition Used to set the value of gain changing condition (command frequency, droop pulses, servo motor speed) selected in [Pr. PB26]. The set value unit changes with the changing condition item.</p>	10	PB27	<p>Same as MR-J3</p>	10	P S		
				<p>Gain switching condition This is used to set the value of gain switching (command frequency, droop pulses, and servo motor speed) selected in [Pr. PB26]. The set value unit differs depending on the switching condition item. Setting range: 0 to 9999</p>				

Part 2: Review on Replacement of MR-J3- _A_ with MR-J4- _A_

MR-J3- _A_			MR-J4- _A_			Control mode
No.	Name and function	Initial value	No.	Name and function	Initial value	
PB28	Gain changing time constant Used to set the time constant at which the gains will change in response to the conditions set in [Pr. PB26] and [Pr. PB27].	1	PB28	Same as MR-J3 Gain switching time constant This is used to set the time constant at which the gains will change in response to the conditions set in [Pr. PB26] and [Pr. PB27]. Setting range: 0 to 100	1	P S
PB29	Gain changing ratio of load inertia moment to servo motor inertia moment Used to set the ratio of load inertia moment to servo motor inertia moment when gain changing is valid. This parameter is made valid when the auto tuning is invalid ([Pr. PA08]: ___ 3).	7.0	PB29	Same as MR-J3 load to motor mass ratio after gain switching This is used to set the load to motor inertia ratio/load to motor mass ratio when gain switching is enabled. This parameter is enabled only when "Gain adjustment mode selection" is "Manual mode (___ 3)" in [Pr. PA08]. Setting range: 0.00 to 300.00 Unit: 1.0 time	7.00	P S
PB30	Gain changing position loop gain Set the position loop gain when the gain changing is valid. This parameter is made valid when the auto tuning is invalid ([Pr. PA08]: ___ 3).	37	PB30	Position loop gain after gain switching Set the position loop gain when the gain switching is enabled. When you set a value less than 1.0 rad/s, the value will be the same as [Pr. PB08]. This parameter is enabled only when "Gain adjustment mode selection" is "Manual mode (___ 3)" in [Pr. PA08]. Setting range: 0.0 to 2000.0	0.0	P
PB31	Gain changing speed loop gain Set the speed loop gain when the gain changing is valid. This parameter is made valid when the auto tuning is invalid ([Pr. PA08]: ___ 3). Note The setting range of 50000 applies to the servo amplifier whose software version is A3 or later. The setting range of the servo amplifier whose software version is older than A3 is 20 to 20000. When the software version of Setup software (SETUP221E) is A3 or earlier, 20001 or more cannot be set. Use the display/operation section of the servo amplifier to set 20001 or more.	823	PB31	Speed loop gain after gain switching Set the speed loop gain when the gain switching is enabled. When you set a value less than 20 rad/s, the value will be the same as [Pr. PB09]. This parameter is enabled only when "Gain adjustment mode selection" is "Manual mode (___ 3)" in [Pr. PA08]. Setting range: 0 to 65535	0	P S
PB32	Gain changing speed integral compensation Set the speed integral compensation when the gain changing is valid. This parameter is made valid when the auto tuning is invalid ([Pr. PA08]: ___ 3).	33.7	PB32	Speed integral compensation after gain switching Set the speed integral compensation when the gain changing is enabled. When you set a value less than 0.1 ms, the value will be the same as [Pr. PB10]. This parameter is enabled only when "Gain adjustment mode selection" is "Manual mode (___ 3)" in [Pr. PA08]. Setting range: 0.0 to 5000.0	0.0	P S

Part 2: Review on Replacement of MR-J3- _A_ with MR-J4- _A_

MR-J3- _A_			MR-J4- _A_			Control mode
No.	Name and function	Initial value	No.	Name and function	Initial value	
PB33	<p>Gain changing vibration suppression control - vibration frequency setting</p> <p>Set the vibration frequency for vibration suppression control when the gain changing is valid. This parameter is made valid when the [Pr. PB02] setting is "___ 2" and the [Pr. PB26] setting is "___ 1".</p> <p>When using the vibration suppression control gain changing, always execute the changing after the servo motor has stopped.</p>	100.0	PB33	<p>Vibration suppression control 1 - Vibration frequency after gain switching</p> <p>Set the vibration frequency for vibration suppression control 1 when the gain switching is enabled.</p> <p>When you set a value less than 0.1 Hz, the value will be the same as [Pr. PB19].</p> <p>This parameter will be enabled only when the following conditions are fulfilled.</p> <ul style="list-style-type: none"> - "Gain adjustment mode selection" in [Pr. PA08] is "Manual mode (___ 3)". - "Vibration suppression control 1 tuning mode selection" in [Pr. PB02] is "Manual setting (___ 2)". - "Gain switching selection" in [Pr. PB26] is "Input device (gain switching (CDP)) (___ 1)". <p>Switching during driving may cause a shock. Be sure to switch them after the servo motor stops.</p> <p>Setting range: 0.0 to 300.0</p>	0.0	P
PB34	<p>Gain changing vibration suppression control - resonance frequency setting</p> <p>Set the resonance frequency for vibration suppression control when the gain changing is valid. This parameter is made valid when the [Pr. PB02] setting is "___ 2" and the [Pr. PB26] setting is "___ 1".</p> <p>When using the vibration suppression control gain changing, always execute the changing after the servo motor has stopped.</p>	100.0	PB34	<p>Vibration suppression control 1 - Resonance frequency after gain switching</p> <p>Set the resonance frequency for vibration suppression control 1 when the gain switching is enabled.</p> <p>When you set a value less than 0.1 Hz, the value will be the same as [Pr. PB20].</p> <p>This parameter will be enabled only when the following conditions are fulfilled.</p> <ul style="list-style-type: none"> - "Gain adjustment mode selection" in [Pr. PA08] is "Manual mode (___ 3)". - "Vibration suppression control 1 tuning mode selection" in [Pr. PB02] is "Manual setting (___ 2)". - "Gain switching selection" in [Pr. PB26] is "Input device (gain switching (CDP)) (___ 1)". <p>Switching during driving may cause a shock. Be sure to switch them after the servo motor stops.</p> <p>Setting range: 0.0 to 300.0</p>	0.0	P
PB35	<p>For manufacturer setting</p> <p>Do not change this value by any means.</p>	0.00	PB35	<p>Vibration suppression control 1 - Vibration frequency damping after gain switching</p> <p>Set a damping of the vibration frequency for vibration suppression control 1 when the gain switching is enabled.</p> <p>This parameter will be enabled only when the following conditions are fulfilled.</p> <ul style="list-style-type: none"> - "Gain adjustment mode selection" in [Pr. PA08] is "Manual mode (___ 3)". - "Vibration suppression control 1 tuning mode selection" in [Pr. PB02] is "Manual setting (___ 2)". - "Gain switching selection" in [Pr. PB26] is "Input device (gain switching (CDP)) (___ 1)". <p>Switching during driving may cause a shock. Be sure to switch them after the servo motor stops.</p> <p>Setting range: 0.00 to 0.30</p>	0.00	P

Part 2: Review on Replacement of MR-J3- _A_ with MR-J4- _A_

MR-J3- _A_			MR-J4- _A_			
No.	Name and function	Initial value	No.	Name and function	Initial value	Control mode
PB36	For manufacturer setting Do not change this value by any means.	0.00	PB36	Vibration suppression control 1 - Resonance frequency damping after gain switching Set a damping of the resonance frequency for vibration suppression control 1 when the gain switching is enabled. This parameter will be enabled only when the following conditions are fulfilled. <ul style="list-style-type: none"> "Gain adjustment mode selection" in [Pr. PA08] is "Manual mode (_ _ _ 3)". "Vibration suppression control 1 tuning mode selection" in [Pr. PB02] is "Manual setting (_ _ _ 2)". "Gain switching selection" in [Pr. PB26] is "Input device (gain switching (CDP)) (_ _ _ 1)". Switching during driving may cause a shock. Be sure to switch them after the servo motor stops. Setting range: 0.00 to 0.30	0.00	P
PC01	Acceleration time constant Used to set the acceleration time required to reach the rated speed from 0 r/min in response to the analog speed command and internal speed commands 1 to 7. For example for the servo motor of 3000 r/min rated speed, set 3000 (3 s) to increase speed from 0 r/min to 1000 r/min in 1 second.	0	PC01	Same as MR-J3 Acceleration time constant Set the acceleration time required to reach the rated speed from 0 r/min for VC (Analog speed command) and [Pr. PC05 Internal speed command 1] to [Pr. PC11 Internal speed command 7]. For example for the servo motor of 3000 r/min rated speed, set 3000 (3 s) to increase the speed from 0 r/min to 1000 r/min in 1 second. Setting range: 0 to 50000	0	S T
PC02	Deceleration time constant Used to set the deceleration time required to reach 0 r/min from the rated speed in response to the analog speed command and internal speed commands 1 to 7.	0	PC02	Same as MR-J3 Deceleration time constant Set the deceleration time required to reach 0 r/min from the rated speed for VC (Analog speed command) and [Pr. PC05 Internal speed command 1] to [Pr. PC11 Internal speed command 7]. Setting range: 0 to 50000	0	S T

Part 2: Review on Replacement of MR-J3- _A_ with MR-J4- _A_

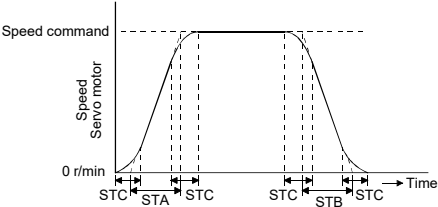
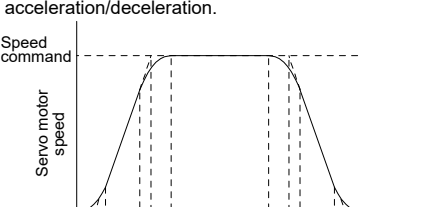
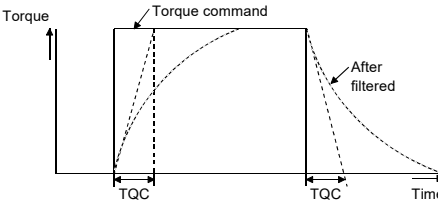
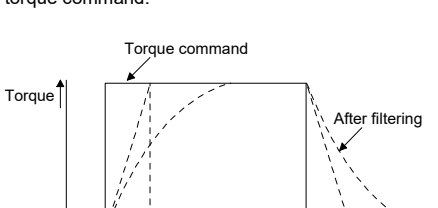
MR-J3- _A_			MR-J4- _A_			
No.	Name and function	Initial value	No.	Name and function	Initial value	Control mode
PC03	<p>S-pattern acceleration/deceleration time constant Used to smooth start/stop of the servo motor. Set the time of the arc part for S-pattern acceleration/deceleration.</p>  <p>STA: Acceleration time constant [Pr. PC01] STB: Deceleration time constant [Pr. PC02] STC: S-pattern acceleration/deceleration time constant [Pr. PC03]</p> <p>Long setting of STA (acceleration time constant) or STB (deceleration time constant) may produce an error in the time of the arc part for the setting of the S-pattern acceleration/deceleration time constant.</p> <p>The upper limit value of the actual arc part time is limited by $\frac{2000000}{STA}$ for acceleration or by $\frac{2000000}{STB}$ for deceleration. (Example) At the setting of STA=20000, STB=5000 and STC=200, the actual arc part times are as follows.</p> <p>During acceleration: 100[ms] $\left[\begin{array}{l} \text{Limited to 100[ms] since} \\ \frac{2000000}{20000} = 100[\text{ms}] < 200[\text{ms}]. \end{array} \right.$</p> <p>During deceleration: 200[ms] $\left[\begin{array}{l} 200[\text{ms}] \text{ as set since} \\ \frac{2000000}{5000} = 400[\text{ms}] > 200[\text{ms}]. \end{array} \right.$</p>	0	PC03	<p>Same as MR-J3</p> <p>S-pattern acceleration/deceleration time constant Start/stop the servo motor smoothly. Set the time of the arc part for S-pattern acceleration/deceleration.</p>  <p>STA: Acceleration time constant ([Pr. PC01]) STB: Deceleration time constant ([Pr. PC02]) STC: S-pattern acceleration/deceleration time constant ([Pr. PC03])</p> <p>Long setting of STA (acceleration time constant) or STB (deceleration time constant) may produce an error in the time of the arc part for the setting of the S-pattern acceleration/deceleration time constant. The upper limit value of the actual arc part time is limited by</p> <p>$\frac{2000000}{STA}$ for acceleration or by $\frac{2000000}{STB}$ for deceleration.</p> <p>(Example) At the setting of STA 20000, STB 5000 and STC 200, the actual arc part times are as follows.</p> <p>Acceleration: 100 ms $\frac{2000000}{20000} = 100 [\text{ms}] < 200 [\text{ms}]$ Therefore, it will be limited to 100 ms.</p> <p>Deceleration: 200 ms $\frac{2000000}{5000} = 400 [\text{ms}] > 200 [\text{ms}]$ Therefore, it will be 200 ms as you set.</p> <p>Setting range: 0 to 5000</p>	0	S T
PC04	<p>Torque command time constant Used to set the constant of a low-pass filter in response to the torque command.</p>  <p>TQC: Torque command time constant</p>	0	PC04	<p>Same as MR-J3</p> <p>Torque command time constant Set the constant of a primary delay filter to the torque command.</p>  <p>TQC: Torque</p> <p>Setting range: 0 to 50000</p>	0	T

Part 2: Review on Replacement of MR-J3- _A_ with MR-J4- _A_

MR-J3- _A_			MR-J4- _A_			Control mode
No.	Name and function	Initial value	No.	Name and function	Initial value	
PC05	Internal speed command 1 Used to set speed 1 of internal speed commands.	100	PC05	Same as MR-J3	100	S
	Internal speed limit 1 Used to set speed 1 of internal speed limits.			Internal speed command 1 Set the speed 1 of internal speed commands. Setting range: 0 to permissible instantaneous speed		
PC06	Internal speed command 2 Used to set speed 2 of internal speed commands.	500	PC06	Same as MR-J3	500	S
	Internal speed limit 2 Used to set speed 2 of internal speed limits.			Internal speed command 2 Set the speed 2 of internal speed commands. Setting range: 0 to permissible instantaneous speed		
PC07	Internal speed command 3 Used to set speed 3 of internal speed commands.	1000	PC07	Same as MR-J3	1000	S
	Internal speed limit 3 Used to set speed 3 of internal speed limits.			Internal speed command 3 Set the speed 3 of internal speed commands. Setting range: 0 to permissible instantaneous speed		
PC08	Internal speed command 4 Used to set speed 4 of internal speed commands.	200	PC08	Same as MR-J3	200	S
	Internal speed limit 4 Used to set speed 4 of internal speed limits.			Internal speed command 4 Set the speed 4 of internal speed commands. Setting range: 0 to permissible instantaneous speed		
PC09	Internal speed command 5 Used to set speed 5 of internal speed commands.	300	PC09	Same as MR-J3	300	S
	Internal speed limit 5 Used to set speed 5 of internal speed limits.			Internal speed command 5 Set the speed 5 of internal speed commands. Setting range: 0 to permissible instantaneous speed		
PC10	Internal speed command 6 Used to set speed 6 of internal speed commands.	500	PC10	Same as MR-J3	500	S
	Internal speed limit 6 Used to set speed 6 of internal speed limits.			Internal speed command 6 Set the speed 6 of internal speed commands. Setting range: 0 to permissible instantaneous speed		

Part 2: Review on Replacement of MR-J3- _A_ with MR-J4- _A_

MR-J3- _A_			MR-J4- _A_			Control mode									
No.	Name and function	Initial value	No.	Name and function	Initial value										
PC11	Internal speed command 7 Used to set speed 7 of internal speed commands.	800	PC11	Same as MR-J3	800	S									
	Internal speed limit 7 Used to set speed 7 of internal speed limits.			Internal speed command 7 Set the speed 7 of internal speed commands. Setting range: 0 to permissible instantaneous speed			Internal speed limit 7 Set the speed 7 of internal speed limits. Setting range: 0 to permissible instantaneous speed								
PC12	Analog speed command maximum speed Used to set the speed at the maximum input voltage (10 V) of the analog speed command (VC). When "0" is set, the analog speed command maximum speed would be the rated speed of the servo motor connected. The speed is as indicated below for motorless operation of test operation.	0	PC12	Same setting as MR-J3	0	S									
	<table border="1"> <thead> <tr> <th colspan="2">Servo amplifier capacity</th> <th>Servo motor speed [r/min]</th> </tr> </thead> <tbody> <tr> <td>100 V class</td> <td>100 W to 400 W</td> <td rowspan="2">3000</td> </tr> <tr> <td>200 V class</td> <td>100 W to 750 W</td> </tr> <tr> <td></td> <td>1 kW to 37 kW</td> <td rowspan="2">2000</td> </tr> <tr> <td>400 V class</td> <td>600 W to 55 kW</td> </tr> </tbody> </table>			Servo amplifier capacity			Servo motor speed [r/min]	100 V class	100 W to 400 W	3000	200 V class	100 W to 750 W		1 kW to 37 kW	2000
Servo amplifier capacity		Servo motor speed [r/min]													
100 V class	100 W to 400 W	3000													
200 V class	100 W to 750 W														
	1 kW to 37 kW	2000													
400 V class	600 W to 55 kW														
PC13	Analog torque command maximum output Used to set the output torque at the analog torque command voltage (TC = ±8 V) of +8 V on the assumption that the maximum torque is 100 [%]. For example, set 50 to output (maximum torque × 50/100) at the TC of +8 V.	100.0	PC13	Same as MR-J3	100.0	T									
				Analog torque command maximum output This is used to set the output torque at the analog torque (TC = ±8 V) of +8 V on the assumption that the maximum torque is 100.0%. For example, set 50.0. The maximum torque × $\frac{50.0}{100.0}$ is outputted. If a value equal to or larger than the maximum torque is inputted to TC, the value will be clamped at the maximum torque. Setting range: 0.0 to 1000.0											

Part 2: Review on Replacement of MR-J3- _A_ with MR-J4- _A_

MR-J3- _A_			MR-J4- _A_																																	
No.	Name and function	Initial value	No.	Name and function	Initial value	Control mode																														
PC14	Analog monitor 1 output Used to selection the signal provided to the analog monitor 1 (MO1) output. 0 0 0 x: Analog monitor 1 (MO1) output selection <table border="1" style="width: 100%; border-collapse: collapse;"> <thead> <tr> <th>Setting</th> <th>Item</th> </tr> </thead> <tbody> <tr><td>0</td><td>Servo motor speed (8 V/max. speed)</td></tr> <tr><td>1</td><td>Torque (8 V/max. torque) (Note 2)</td></tr> <tr><td>2</td><td>Servo motor speed (+8 V/max. speed)</td></tr> <tr><td>3</td><td>Torque (+8 V/max. torque) (Note 2)</td></tr> <tr><td>4</td><td>Current command (8 V/max. current command)</td></tr> <tr><td>5</td><td>Command pulse frequency (10 V/1 Mpulse/s)</td></tr> <tr><td>6</td><td>Droop pulses (10 V/100 pulses) (Note 1)</td></tr> <tr><td>7</td><td>Droop pulses (10 V/1000 pulses) (Note 1)</td></tr> <tr><td>8</td><td>Droop pulses (10 V/10000 pulses) (Note 1)</td></tr> <tr><td>9</td><td>Droop pulses (10 V/100000 pulses) (Note 1)</td></tr> <tr><td>A</td><td>Feedback position (10 V/1 Mpulse) (Note 1)</td></tr> <tr><td>B</td><td>Feedback position (10 V/10 Mpulses) (Note 1)</td></tr> <tr><td>C</td><td>Feedback position (10 V/100 Mpulses) (Note 1)</td></tr> <tr><td>D</td><td>Bus voltage (8 V/400 V) (Note 3)</td></tr> </tbody> </table>	Setting	Item	0	Servo motor speed (8 V/max. speed)	1	Torque (8 V/max. torque) (Note 2)	2	Servo motor speed (+8 V/max. speed)	3	Torque (+8 V/max. torque) (Note 2)	4	Current command (8 V/max. current command)	5	Command pulse frequency (10 V/1 Mpulse/s)	6	Droop pulses (10 V/100 pulses) (Note 1)	7	Droop pulses (10 V/1000 pulses) (Note 1)	8	Droop pulses (10 V/10000 pulses) (Note 1)	9	Droop pulses (10 V/100000 pulses) (Note 1)	A	Feedback position (10 V/1 Mpulse) (Note 1)	B	Feedback position (10 V/10 Mpulses) (Note 1)	C	Feedback position (10 V/100 Mpulses) (Note 1)	D	Bus voltage (8 V/400 V) (Note 3)	0000h	PC14	Analog monitor 1 output ___ x x: Analog monitor 1 output selection Select a signal to output to MO1 (Analog monitor 1). Refer to table 2.6 for settings.	00h	P S T
		Setting	Item																																	
0	Servo motor speed (8 V/max. speed)																																			
1	Torque (8 V/max. torque) (Note 2)																																			
2	Servo motor speed (+8 V/max. speed)																																			
3	Torque (+8 V/max. torque) (Note 2)																																			
4	Current command (8 V/max. current command)																																			
5	Command pulse frequency (10 V/1 Mpulse/s)																																			
6	Droop pulses (10 V/100 pulses) (Note 1)																																			
7	Droop pulses (10 V/1000 pulses) (Note 1)																																			
8	Droop pulses (10 V/10000 pulses) (Note 1)																																			
9	Droop pulses (10 V/100000 pulses) (Note 1)																																			
A	Feedback position (10 V/1 Mpulse) (Note 1)																																			
B	Feedback position (10 V/10 Mpulses) (Note 1)																																			
C	Feedback position (10 V/100 Mpulses) (Note 1)																																			
D	Bus voltage (8 V/400 V) (Note 3)																																			
___ x ___: For manufacturer setting x ___ : For manufacturer setting Table 2.6 Analog monitor setting value (MR-J4- _A_ (-RJ) 100 W or more) <table border="1" style="width: 100%; border-collapse: collapse;"> <thead> <tr> <th>Setting value</th> <th>Item</th> </tr> </thead> <tbody> <tr><td>___ 0 0</td><td>Servo motor speed (±8 V/max. speed)</td></tr> <tr><td>___ 0 1</td><td>Torque (±8 V/max. torque) (Note 2)</td></tr> <tr><td>___ 0 2</td><td>Servo motor speed (+8 V/max. speed)</td></tr> <tr><td>___ 0 3</td><td>Torque (+8 V/max. torque) (Note 2)</td></tr> <tr><td>___ 0 4</td><td>Current command (±8 V/max. current command)</td></tr> <tr><td>___ 0 5</td><td>Command pulse frequency (±10 V/±4 Mpulses/s)</td></tr> <tr><td>___ 0 6</td><td>Servo motor-side droop pulses (±10 V/100 pulses) (Note 1)</td></tr> <tr><td>___ 0 7</td><td>Servo motor-side droop pulses (±10 V/1000 pulses) (Note 1)</td></tr> <tr><td>___ 0 8</td><td>Servo motor-side droop pulses (±10 V/10000 pulses) (Note 1)</td></tr> <tr><td>___ 0 9</td><td>Servo motor-side droop pulses (±10 V/100000 pulses) (Note 1)</td></tr> <tr><td>___ 0 A</td><td>Feedback position (±10 V/1 Mpulse) (Note 1)</td></tr> <tr><td>___ 0 B</td><td>Feedback position (±10 V/10 Mpulses) (Note 1)</td></tr> <tr><td>___ 0 C</td><td>Feedback position (±10 V/100 Mpulses) (Note 1)</td></tr> <tr><td>___ 0 D</td><td>Bus voltage (200 V class and 100 V class: +8 V/400 V, 400 V class: +8 V/800 V)</td></tr> </tbody> </table>	Setting value	Item	___ 0 0	Servo motor speed (±8 V/max. speed)	___ 0 1	Torque (±8 V/max. torque) (Note 2)	___ 0 2	Servo motor speed (+8 V/max. speed)	___ 0 3	Torque (+8 V/max. torque) (Note 2)	___ 0 4	Current command (±8 V/max. current command)	___ 0 5	Command pulse frequency (±10 V/±4 Mpulses/s)	___ 0 6	Servo motor-side droop pulses (±10 V/100 pulses) (Note 1)	___ 0 7	Servo motor-side droop pulses (±10 V/1000 pulses) (Note 1)	___ 0 8	Servo motor-side droop pulses (±10 V/10000 pulses) (Note 1)	___ 0 9	Servo motor-side droop pulses (±10 V/100000 pulses) (Note 1)	___ 0 A	Feedback position (±10 V/1 Mpulse) (Note 1)	___ 0 B	Feedback position (±10 V/10 Mpulses) (Note 1)	___ 0 C	Feedback position (±10 V/100 Mpulses) (Note 1)	___ 0 D	Bus voltage (200 V class and 100 V class: +8 V/400 V, 400 V class: +8 V/800 V)						
Setting value	Item																																			
___ 0 0	Servo motor speed (±8 V/max. speed)																																			
___ 0 1	Torque (±8 V/max. torque) (Note 2)																																			
___ 0 2	Servo motor speed (+8 V/max. speed)																																			
___ 0 3	Torque (+8 V/max. torque) (Note 2)																																			
___ 0 4	Current command (±8 V/max. current command)																																			
___ 0 5	Command pulse frequency (±10 V/±4 Mpulses/s)																																			
___ 0 6	Servo motor-side droop pulses (±10 V/100 pulses) (Note 1)																																			
___ 0 7	Servo motor-side droop pulses (±10 V/1000 pulses) (Note 1)																																			
___ 0 8	Servo motor-side droop pulses (±10 V/10000 pulses) (Note 1)																																			
___ 0 9	Servo motor-side droop pulses (±10 V/100000 pulses) (Note 1)																																			
___ 0 A	Feedback position (±10 V/1 Mpulse) (Note 1)																																			
___ 0 B	Feedback position (±10 V/10 Mpulses) (Note 1)																																			
___ 0 C	Feedback position (±10 V/100 Mpulses) (Note 1)																																			
___ 0 D	Bus voltage (200 V class and 100 V class: +8 V/400 V, 400 V class: +8 V/800 V)																																			
	Note 1. Encoder pulse unit. 2. 8 V is outputted at the maximum torque. However, when [Pr. PA11] [Pr. PA12] are set to limit torque, 8 V is outputted at the torque highly limited. 3. For 400 V class servo amplifier, the bus voltage becomes +8 V/800 V.			Note 1. Encoder pulse unit 2. The larger value of [Pr. PA11] or [Pr. PA12] will be the maximum torque.																																
PC15	Analog monitor 2 output Used to selection the signal provided to the analog monitor 2 (MO2) output. 0 0 0 x: Select the analog monitor 2 (MO2) output The settings are the same as those of [Pr. PC14]	0001h	PC15	Analog monitor 2 output ___ x x: Analog monitor 2 output selection Select a signal to output to MO2 (Analog monitor 2). Refer to [Pr. PC14] for settings.	01h	P S T																														
				___ x ___: For manufacturer setting x ___ : For manufacturer setting			0h	0h																												
PC16	Electromagnetic brake sequence output Used to set the delay time (Tb) between electronic brake interlock (MBR) and the base drive circuit is shut-off.	100	PC16	Same as MR-J3 Analog monitor 2 output Set the delay time between MBR (Electromagnetic brake interlock) and the base drive circuit is shut-off. Setting range: 0 to 1000	0	P S T																														
PC17	Zero speed Used to set the output range of the zero speed detection (ZSP). Zero speed detection (ZSP) has hysteresis width of 20 r/min	50	PC17	Same as MR-J3 Zero speed Set the output range of ZSP (Zero speed detection). ZSP (Zero speed detection) has hysteresis of 20 r/min. Setting range: 0 to 10000	50	P S T																														

Part 2: Review on Replacement of MR-J3- _A_ with MR-J4- _A_

MR-J3- _A_			MR-J4- _A_			Control mode											
No.	Name and function	Initial value	No.	Name and function	Initial value												
PC18	Alarm history clear Used to clear the alarm history. 0 0 0 x: Alarm history clear 0: Invalid 1: Valid When alarm history clear is made valid, the alarm history is cleared at next power-on. After the alarm history is cleared, the setting is automatically made invalid (reset to 0).	0000h	PC18	Same as MR-J3	0h	P S T											
				Alarm history clear selection ___ x: Clear the alarm history. 0: Disabled 1: Enabled When "Enabled" is set, the alarm history will be cleared at the next power-on. After the alarm history is cleared, the setting is automatically disabled.													
				__ x _: For manufacturer setting			0h										
				_ x _ _: For manufacturer setting			0h										
				x _ _ _: For manufacturer setting	0h												
PC19	Encoder output pulses selection Use to select the, encoder output pulses direction and encoder output pulses setting. 0 0 0 x: Encoder output pulses phase changing Changes the phases of A/B-phase encoder output pulses. <table border="1"> <thead> <tr> <th rowspan="2">Set value</th> <th colspan="2">Servo motor rotation direction</th> </tr> <tr> <th>CCW</th> <th>CW</th> </tr> </thead> <tbody> <tr> <td>0</td> <td>A-phase </td> <td>A-phase </td> </tr> <tr> <td>1</td> <td>A-phase </td> <td>A-phase </td> </tr> </tbody> </table>	Set value	Servo motor rotation direction		CCW	CW	0	A-phase	A-phase	1	A-phase	A-phase	0000h	PC19	Same setting as MR-J3	0h	P S T
			Set value	Servo motor rotation direction													
		CCW		CW													
		0	A-phase	A-phase													
1	A-phase	A-phase															
Encoder output pulse selection ___ x: Encoder output pulse phase selection Select the encoder pulse direction. 0: A-phase 90° shift in CCW 1: A-phase 90° shift in CW																	
				__ x _: Encoder output pulse setting selection 0: Output pulse setting When "_ 1 0 _" is set to this parameter, [AL. 37 Parameter error] will occur. 1: Dividing ratio setting 2: The same output pulse setting as the command pulse 3: A-phase/B-phase pulse electronic gear setting When you select "1", the setting of [Pr. PA16 Encoder output pulses 2] will be disabled. When you select "2", the settings of [Pr. PA15 Encoder output pulses] and [Pr. PA16 Encoder output pulses 2] will be disabled. When you select the setting, do not change the settings in [Pr. PA06] and [Pr. PA07] after the power-on.													
				_ x _ _: Selection of the encoders for encoder output pulse Select an encoder used for the encoder output pulses which the servo amplifier outputs. 0: Servo motor encoder 1: Load-side encoder When "_ 1 0 _" is set to this parameter, [AL. 37 Parameter error] will occur.	0h	P											
				x _ _ _: For manufacturer setting	0h												

Part 2: Review on Replacement of MR-J3- _A_ with MR-J4- _A_

MR-J3- _A_			MR-J4- _A_			Control mode
No.	Name and function	Initial value	No.	Name and function	Initial value	
PC20	<p>Station number setting</p> <p>Used to specify the station number for serial communication.</p> <p>Always set one station to one axis of servo amplifier. If one station number is set to two or more stations, normal communication cannot be made.</p>	0	PC20	<p>Same setting as MR-J3</p> <p>Station No. setting</p> <p>Specify a station number of the servo amplifier for RS-422 and USB communications.</p> <p>Always set one station to one axis of the servo amplifier. Setting one station number to two or more stations will disable a normal communication.</p> <p>Setting range: 0 to 31</p>	0	P S T
PC21	<p>Communication function selection</p> <p>Select the communication I/F and select the RS-422 communication conditions.</p> <p>0 0 x 0:</p> <p>RS-422 communication baud rate selection</p> <p>0: 9600 [bps]</p> <p>1: 19200 [bps]</p> <p>2: 38400 [bps]</p> <p>3: 57600 [bps]</p> <p>4: 115200 [bps]</p> <p>0 x 0 0:</p> <p>RS-422 communication response delay time</p> <p>0: Invalid</p> <p>1: Valid, reply sent after delay time of 800 μs or longer</p>	0000h	PC21	<p>RS-422 communication function selection</p> <p>Select the communication I/F and select the RS-422 communication conditions.</p>		
				<p>__ _ x:</p> <p>For manufacturer setting</p>	0h	
				<p>_ _ x _:</p> <p>RS-422 communication baud rate selection</p> <p>When using the parameter unit, set "1 _ _ _" in [Pr. PF34].</p> <p>0: 9600 [bps]</p> <p>1: 19200 [bps]</p> <p>2: 38400 [bps]</p> <p>3: 57600 [bps]</p> <p>4: 115200 [bps]</p>	0h	P S T
				<p>_ x _ _:</p> <p>RS-422 communication response delay time selection</p> <p>0: Disabled</p> <p>1: Enabled (responding after 800 μs or longer delay time)</p>	0h	P S T
PC22	<p>Function selection C-1</p> <p>Select the execution of automatic restart after instantaneous power failure selection, and encoder cable communication system selection.</p> <p>0 0 0 x:</p> <p>Restart after instantaneous power failure selection</p> <p>If the power supply voltage has returned to normal after an undervoltage status caused by the reduction of the input power supply voltage in the speed control mode, the servo motor can be restarted by merely turning on the start signal without resetting the alarm.</p> <p>0: Invalid ([AL. 10 Undervoltage alarm] occurs.)</p> <p>1: Valid (If this function is enabled for the drive unit of 30 kW or more, [AL. 37 Parameter error] occurs.)</p> <p>x 0 0 0:</p> <p>Encoder cable communication system selection</p> <p>0: Two-wire type</p> <p>1: Four-wire type</p> <p>The following encoder cables are four-wire type.</p> <p>MR-EKCBL30M-L</p> <p>MR-EKCBL30M-H</p> <p>MR-EKCBL40M-H</p> <p>MR-EKCBL50M-H</p> <p>Other encoder cables are two-wire type.</p> <p>Incorrect setting will result in [AL. 16 Encoder error 1 (At power on)].</p>	0000h	PC22	<p>__ _ x:</p> <p>For manufacturer setting</p>	0h	
				<p>_ _ x _:</p> <p>For manufacturer setting</p>	0h	
				<p>_ x _ _:</p> <p>For manufacturer setting</p>	0h	
				<p>Function selection C-1</p> <p>x _ _ _:</p> <p>Encoder cable communication method selection</p> <p>Select how to execute the encoder cable communication method.</p> <p>0: Two-wire type</p> <p>1: Four-wire type</p> <p>When using an encoder of A/B/Z-phase differential output method, set "0".</p> <p>If the setting is incorrect, [AL. 16 Encoder initial communication error 1] or [AL. 20 Encoder normal communication error 1] occurs.</p>	0h	P S T

Part 2: Review on Replacement of MR-J3- _A_ with MR-J4- _A_

MR-J3- _A_			MR-J4- _A_			Control mode																
No.	Name and function	Initial value	No.	Name and function	Initial value																	
PC23	<p>Function selection C-2</p> <p>Select the servo lock at speed control mode stop, the VC-VLA voltage averaging, and the speed limit in torque control mode.</p> <p>0 0 0 x:</p> <p>Selection of servo lock at stop In the speed control mode, the servo motor shaft can be locked to prevent the shaft from being moved by the external force.</p> <p>0: Valid (Servo-locked)</p> <p>The operation to maintain the stop position is performed.</p> <p>1: Invalid (Not servo-locked)</p> <p>The stop position is not maintained.</p> <p>The control to make the speed 0 r/min is performed.</p>	0000h	PC23	<p>Same as MR-J3</p> <p>Function selection C-2</p> <p>__ _ x:</p> <p>Servo-lock selection at speed control stop</p> <p>Select the servo-lock selection at speed control stop. In the speed control mode, the servo motor shaft can be locked to prevent the shaft from being moved by an external force.</p> <p>0: Enabled (servo-lock)</p> <p>The operation to maintain the stop position is performed.</p> <p>1: Disabled (no servo-lock)</p> <p>The stop position is not maintained.</p> <p>The control to make the speed 0 r/min is performed.</p>	0h	S																
	<p>0 x 0 0:</p> <p>VC/VLA voltage averaging</p> <p>Used to set the filtering time when the analog speed command (VC) voltage or analog speed limit (VLA) is imported.</p> <p>Set 0 to vary the speed to voltage fluctuation in real time. Increase the set value to vary the speed slower to voltage fluctuation.</p> <table border="1"> <thead> <tr> <th>Set value</th> <th>Filtering time [ms]</th> </tr> </thead> <tbody> <tr> <td>0</td> <td>0</td> </tr> <tr> <td>1</td> <td>0.444</td> </tr> <tr> <td>2</td> <td>0.888</td> </tr> <tr> <td>3</td> <td>1.777</td> </tr> <tr> <td>4</td> <td>3.555</td> </tr> <tr> <td>5</td> <td>7.111</td> </tr> </tbody> </table>			Set value			Filtering time [ms]	0	0	1	0.444	2	0.888	3	1.777	4	3.555	5	7.111	<p>__ _ x _:</p> <p>For manufacturer setting</p>	0h	
	Set value			Filtering time [ms]																		
0	0																					
1	0.444																					
2	0.888																					
3	1.777																					
4	3.555																					
5	7.111																					
<p>x 0 0 0:</p> <p>Selection of speed limit for torque control</p> <p>0: Valid</p> <p>1: Invalid</p> <p>Do not use this function except when configuring a speed loop externally.</p> <p>If the speed limit is invalid, the following parameters can be used.</p> <p>[Pr. PB01] (Adaptive tuning mode (Adaptive filter))</p> <p>[Pr. PB13] (machine resonance suppression filter 1)</p> <p>[Pr. PB14] (notch shape selection 1)</p> <p>[Pr. PB15] (machine resonance suppression filter 2)</p> <p>[Pr. PB16] (notch shape selection 2)</p>	<p>_ x _ _:</p> <p>VC/VLA voltage averaging selection</p> <p>Select the VC/VLA voltage average.</p> <p>Set the filtering time when VC (Analog speed command) or VLA (Analog speed limit) is imported.</p> <p>Set 0 to vary the speed to voltage fluctuation in real time. Increase the set value to vary the speed slower to voltage fluctuation.</p> <table border="1"> <thead> <tr> <th>Setting value</th> <th>Filtering time [ms]</th> </tr> </thead> <tbody> <tr> <td>0</td> <td>0</td> </tr> <tr> <td>1</td> <td>0.444</td> </tr> <tr> <td>2</td> <td>0.888</td> </tr> <tr> <td>3</td> <td>1.777</td> </tr> <tr> <td>4</td> <td>3.555</td> </tr> <tr> <td>5</td> <td>7.111</td> </tr> </tbody> </table>	Setting value	Filtering time [ms]	0	0	1	0.444	2	0.888	3	1.777	4	3.555	5	7.111	0h	S T					
Setting value	Filtering time [ms]																					
0	0																					
1	0.444																					
2	0.888																					
3	1.777																					
4	3.555																					
5	7.111																					
PC24	<p>Function selection C-3</p> <p>Select the unit of the in-position range</p> <p>0 0 0 x:</p> <p>In-position range unit selection</p> <p>0: Command input pulse unit</p> <p>1: Servo motor encoder pulse unit</p>	0000h	PC24	<p>Function selection C-3</p> <p>In-position range unit selection</p> <p>__ _ x:</p> <p>Select a unit of in-position range.</p> <p>0: Command input pulse unit</p> <p>1: Servo motor encoder pulse unit</p>	0h	P																
				<p>__ _ x _:</p> <p>For manufacturer setting</p>			0h															
				<p>_ x _ _:</p> <p>For manufacturer setting</p>			0h															
<p>x _ _ _:</p> <p>Error excessive alarm/error excessive warning level unit selection</p> <p>Select units for error excessive alarm level setting with [Pr. PC43] and for error excessive warning level setting with [Pr. PC73].</p> <p>0: Per 1 rev</p> <p>1: Per 0.1 rev</p> <p>2: Per 0.01 rev</p> <p>3: Per 0.001 rev</p>	<p>x _ _ _:</p> <p>Error excessive alarm/error excessive warning level unit selection</p> <p>Select units for error excessive alarm level setting with [Pr. PC43] and for error excessive warning level setting with [Pr. PC73].</p> <p>0: Per 1 rev</p> <p>1: Per 0.1 rev</p> <p>2: Per 0.01 rev</p> <p>3: Per 0.001 rev</p>	0h	P																			

Part 2: Review on Replacement of MR-J3- _A_ with MR-J4- _A_

MR-J3- _A_			MR-J4- _A_			Control mode	
No.	Name and function	Initial value	No.	Name and function	Initial value		
PC26	Function selection C-5 Select the [AL. 99 stroke limit warning] 0 0 0 x: [AL. 99 Stroke limit warning] selection 0: Valid 1: Invalid When this parameter is set to "1", [AL. 99] will not occur if the forward rotation stroke end (LSP) or reverse rotation stroke end (LSN) turns OFF.	0000h	PC26	Same as MR-J3 Function selection C-5 ___ x: [AL. 99 Stroke limit warning] selection Enable or disable [AL. 99 Stroke limit warning]. 0: Enabled 1: Disabled	0h	P S	
				___ x _: For manufacturer setting			0h
				_ x _ _: For manufacturer setting			0h
				x _ _ _: For manufacturer setting			0h
PC27	Function selection C-6 Set this function if undervoltage alarm occurs because of distorted power supply voltage waveform when using power regenerative converter or power regenerative common converter. 0 0 0 x: Control circuit power supply undervoltage alarm detection method selection 0: Initial value 1: Set "1" if undervoltage alarm occurs because of distorted power supply voltage waveform when using power regenerative converter or power regenerative common converter.	0000h	PC27	Function selection C-6 ___ x: [AL. 10 Undervoltage] detection method selection Set this parameter when [AL. 10 undervoltage] occurs due to power supply voltage distortion while using FR-RC-(H) or FR-CV-(H). 0: When [AL. 10] does not occur 1: When [AL. 10] occurs	0h	P S T	
				___ x _: Main circuit power supply selection This digit is not available with MR-J4- _A_ (-RJ) 100 W or more servo amplifiers.			0h
				_ x _ _: Undervoltage alarm selection Select the alarm and warning for when the bus voltage drops to the undervoltage alarm level. 0: [AL. 10.2 Voltage drop in the main circuit power] regardless of servo motor speed 1: [AL. E9.1 Servo-on signal on during main circuit off] at servo motor speed 50 r/min or less, [AL. 10.2] at over 50 r/min			0h
				x _ _ _: For manufacturer setting			0h
PC30	Acceleration time constant 2 This parameter is made valid when the acceleration/deceleration selection (STAB2) is turned ON. Used to set the acceleration time required to reach the rated speed from 0 r/min in response to the analog speed command and internal speed commands 1 to 7.	0	PC30	Same as MR-J3 Acceleration time constant 2 To enable the parameter, turn on STAB2 (Speed acceleration/deceleration selection). Set the acceleration time required to reach the rated speed from 0 r/min for VC (Analog speed command) and [Pr. PC05 Internal speed command 1] to [Pr. PC11 Internal speed command 7]. Setting range: 0 to 50000	0	S T	
				Deceleration time constant 2 To enable the parameter, turn on STAB2 (Speed acceleration/deceleration selection). Set the deceleration time required to reach 0 r/min from the rated speed for VC (Analog speed command) and [Pr. PC05 Internal speed command 1] to [Pr. PC11 Internal speed command 7]. Setting range: 0 to 50000			
PC31	Deceleration time constant 2 This parameter is made valid when the acceleration/deceleration selection (STAB2) is turned ON. Used to set the deceleration time required to reach 0 r/min from the rated speed in response to the analog speed command and internal speed commands 1 to 7.	0	PC31	Same as MR-J3 Deceleration time constant 2 To enable the parameter, turn on STAB2 (Speed acceleration/deceleration selection). Set the deceleration time required to reach 0 r/min from the rated speed for VC (Analog speed command) and [Pr. PC05 Internal speed command 1] to [Pr. PC11 Internal speed command 7]. Setting range: 0 to 50000	0	S T	
				Deceleration time constant 2 To enable the parameter, turn on STAB2 (Speed acceleration/deceleration selection). Set the deceleration time required to reach 0 r/min from the rated speed for VC (Analog speed command) and [Pr. PC05 Internal speed command 1] to [Pr. PC11 Internal speed command 7]. Setting range: 0 to 50000			

Part 2: Review on Replacement of MR-J3- _A_ with MR-J4- _A_

MR-J3- _A_			MR-J4- _A_			Control mode
No.	Name and function	Initial value	No.	Name and function	Initial value	
PC32	Command pulse multiplying factor numerator 2 Available when the [Pr. PA05] is set to "0".	1	PC32	Command pulse multiplication numerator 2 To enable the parameter, select "Electronic gear (0 ___)" or "J3 electronic gear setting value compatibility mode (2 ___)" of "Electronic gear selection" in [Pr. PA21]. Setting range: 1 to 16777215	1	P
PC33	Command pulse multiplying factor numerator 3 Available when the [Pr. PA05] is set to "0".	1	PC33	Command pulse multiplication numerator 3 To enable the parameter, select "Electronic gear (0 ___)" or "J3 electronic gear setting value compatibility mode (2 ___)" of "Electronic gear selection" in [Pr. PA21]. Setting range: 1 to 16777215	1	P
PC34	Command pulse multiplying factor numerator 4 Available when the [Pr. PA05] is set to "0".	1	PC34	Command pulse multiplication numerator 4 To enable the parameter, select "Electronic gear (0 ___)" or "J3 electronic gear setting value compatibility mode (2 ___)" of "Electronic gear selection" in [Pr. PA21]. Setting range: 1 to 16777215	1	P
PC35	Internal torque limit 2 Set this parameter to limit servo motor torque on the assumption that the maximum torque is 100 [%]. When 0 is set, torque is not produced. When torque is output in analog monitor output, this set value is the maximum output voltage (8 V).	100.0	PC35	Internal torque limit 2 Set the parameter on the assumption that the maximum torque is 100.0%. The parameter is for limiting the torque of the servo motor. No torque is generated when this parameter is set to "0.0". When TL1 (Internal torque limit selection) is turned on, Internal torque limits 1 and 2 are compared and the lower value will be enabled. Setting range: 0.0 to 100.0	100.0	P S T

Part 2: Review on Replacement of MR-J3- _A_ with MR-J4- _A_

MR-J3- _A_			MR-J4- _A_																																
No.	Name and function	Initial value	No.	Name and function	Initial value	Control mode																													
PC36	<p>Status display selection</p> <p>Select the status display to be provided at power-on.</p> <p>0 0 0 x:</p> <p>Selection of status display at power-on</p> <p>0: Cumulative feedback pulse</p> <p>1: Servo motor speed</p> <p>2: Droop pulse</p> <p>3: Cumulative command pulses</p> <p>4: Command pulse frequency</p> <p>5: Analog speed command voltage (Note 1)</p> <p>6: Analog torque command voltage (Note 2)</p> <p>7: Regenerative load ratio</p> <p>8: Effective load ratio</p> <p>9: Peak load ratio</p> <p>A: Instantaneous torque</p> <p>B: Within one-revolution position (1 pulse unit)</p> <p>C: Within one-revolution position (100 pulses unit)</p> <p>D: ABS counter</p> <p>E: Load inertia moment ratio</p> <p>F: Bus voltage</p> <p>Note 1. In speed control mode. Analog speed limit voltage in torque control mode.</p> <p>2. In torque control mode. Analog torque limit voltage in speed or position control mode.</p>	0000h	PC36	<p>Status display selection</p> <p>__ x x:</p> <p>Status display selection at power-on</p> <p>Select a status display shown at power-on. Setting "21" to "27" will trigger [AL. 37 Parameter error] in the mode other than the positioning mode.</p> <p>00: Cumulative feedback pulses</p> <p>01: Servo motor speed</p> <p>02: Droop pulses</p> <p>03: Cumulative command pulses</p> <p>04: Command pulse frequency</p> <p>05: Analog speed command voltage (Note 1)</p> <p>06: Analog torque command voltage (Note 2)</p> <p>07: Regenerative load ratio</p> <p>08: Effective load ratio</p> <p>09: Peak load ratio</p> <p>0A: Instantaneous torque</p> <p>0B: Within one-revolution position/virtual one-revolution position (1 pulse unit)</p> <p>0C: Within one-revolution position/virtual one-revolution position (1000 pulses unit)</p> <p>0D: ABS counter/virtual ABS counter</p> <p>0E: Load to motor inertia ratio</p> <p>0F: Bus voltage</p> <p>Note 1. It is for the speed control mode. It will be the analog speed limit voltage in the torque control mode.</p> <p>2. It is for the torque control mode. It will be the analog torque limit voltage in the speed control mode and position control mode.</p>	00h	P S T																													
			0 x 0 0:	<p>Status display at power-on in corresponding control mode</p> <table border="1"> <thead> <tr> <th>Control mode</th> <th>Status display at power-on</th> </tr> </thead> <tbody> <tr> <td>Position</td> <td>Cumulative feedback pulses</td> </tr> <tr> <td>Position/speed</td> <td>Cumulative feedback pulses/servo motor speed</td> </tr> <tr> <td>Speed</td> <td>Servo motor speed</td> </tr> <tr> <td>Speed/torque</td> <td>Servo motor speed/analog torque command voltage</td> </tr> <tr> <td>Torque</td> <td>Analog torque command voltage</td> </tr> <tr> <td>Torque/position</td> <td>Analog torque command voltage/cumulative feedback pulses</td> </tr> </tbody> </table> <p>0: Depends on the control mode.</p> <p>1: Depends on the first digit setting of this parameter.</p>	Control mode	Status display at power-on	Position	Cumulative feedback pulses	Position/speed	Cumulative feedback pulses/servo motor speed	Speed	Servo motor speed	Speed/torque	Servo motor speed/analog torque command voltage	Torque	Analog torque command voltage	Torque/position	Analog torque command voltage/cumulative feedback pulses	<p>__ x __:</p> <p>Status display at power-on in corresponding control mode</p> <p>0: Depends on the control mode</p> <p>1: Depends on the last 2 digits settings of the parameter</p> <table border="1"> <thead> <tr> <th>Control mode</th> <th>Status display at power-on</th> </tr> </thead> <tbody> <tr> <td>Position</td> <td>Cumulative feedback pulses</td> </tr> <tr> <td>Position/speed</td> <td>Cumulative feedback pulses/servo motor speed</td> </tr> <tr> <td>Speed</td> <td>Servo motor speed</td> </tr> <tr> <td>Speed/torque</td> <td>Servo motor speed/analog torque command voltage</td> </tr> <tr> <td>Torque</td> <td>Analog torque command voltage</td> </tr> <tr> <td>Torque/position</td> <td>Analog torque command voltage/cumulative feedback pulses</td> </tr> </tbody> </table>	Control mode	Status display at power-on	Position	Cumulative feedback pulses	Position/speed	Cumulative feedback pulses/servo motor speed	Speed	Servo motor speed	Speed/torque	Servo motor speed/analog torque command voltage	Torque	Analog torque command voltage	Torque/position	Analog torque command voltage/cumulative feedback pulses	0h	P S T
			Control mode	Status display at power-on																															
Position	Cumulative feedback pulses																																		
Position/speed	Cumulative feedback pulses/servo motor speed																																		
Speed	Servo motor speed																																		
Speed/torque	Servo motor speed/analog torque command voltage																																		
Torque	Analog torque command voltage																																		
Torque/position	Analog torque command voltage/cumulative feedback pulses																																		
Control mode	Status display at power-on																																		
Position	Cumulative feedback pulses																																		
Position/speed	Cumulative feedback pulses/servo motor speed																																		
Speed	Servo motor speed																																		
Speed/torque	Servo motor speed/analog torque command voltage																																		
Torque	Analog torque command voltage																																		
Torque/position	Analog torque command voltage/cumulative feedback pulses																																		
			x __ __:	For manufacturer setting	0h																														

Part 2: Review on Replacement of MR-J3- _A_ with MR-J4- _A_

MR-J3- _A_			MR-J4- _A_			Control mode
No.	Name and function	Initial value	No.	Name and function	Initial value	
PC37	<p>Analog speed command offset</p> <p>Used to set the offset voltage of the analog speed command (VC).</p> <p>For example, if CCW rotation is provided by switching on forward rotation start (ST1) with 0 V applied to VC, set a negative value.</p> <p>When automatic VC offset is used, the automatically offset value is set to this parameter.</p> <p>The initial value is the value provided by the automatic VC offset function before shipment at the VC-LG voltage of 0 V.</p>	Depending on servo amplifier	PC37	<p>Same as MR-J3</p> <p>Analog speed command offset</p> <p>Set the offset voltage of VC (Analog speed command).</p> <p>For example, if CCW rotation or positive direction travel is provided by switching on ST1 (Forward rotation start) while applying 0 V to VC, set a negative value.</p> <p>When automatic VC offset is used, the automatically offset value is set to this parameter.</p> <p>The initial value is provided before shipment by the automatic VC offset function on condition that the voltage between VC and LG is 0 V.</p> <p>Setting range: -9999 to 9999</p>	The value differs depending on the servo amplifiers.	S
	<p>Analog speed limit offset</p> <p>Used to set the offset voltage of the analog speed limit (VLA).</p> <p>For example, if CCW rotation is provided by switching on forward rotation selection (RS1) with 0 V applied to VLA, set a negative value.</p> <p>When automatic VC offset is used, the automatically offset value is set to this parameter.</p> <p>The initial value is the value provided by the automatic VC offset function before shipment at the VLA-LG voltage of 0 V.</p>			<p>Analog speed limit offset</p> <p>Set the offset voltage of VLA (Analog speed limit).</p> <p>For example, if CCW rotation or positive direction travel is provided by switching on RS1 (Forward rotation selection) while applying 0 V to VLA, set a negative value.</p> <p>When automatic VC offset is used, the automatically offset value is set to this parameter.</p> <p>The initial value is provided before shipment by the automatic VC offset function on condition that the voltage between VLA and LG is 0 V.</p> <p>Setting range: -9999 to 9999</p>		
PC38	<p>Analog torque command offset</p> <p>Used to set the offset voltage of the analog torque command (TC).</p>	0	PC38	<p>Analog torque command offset</p> <p>Set the offset voltage of TC (Analog torque command).</p> <p>Setting range: -9999 to 9999 mV</p>	0	T
	<p>Analog torque limit offset</p> <p>Used to set the offset voltage of the analog torque limit (TLA).</p>			<p>Analog torque limit offset</p> <p>Set the offset voltage of TLA (Analog torque limit).</p> <p>Setting range: -9999 to 9999 mV</p>		
PC39	<p>Analog monitor 1 offset</p> <p>Used to set the offset voltage of the analog monitor (MO1).</p>	0	PC39	<p>Same as MR-J3</p> <p>Analog monitor 1 offset</p> <p>Set the offset voltage of MO1 (Analog monitor 1).</p> <p>Setting range: -9999 to 9999 mV</p>	0	P S T
PC40	<p>Analog monitor 2 offset</p> <p>Used to set the offset voltage of the analog monitor (MO2).</p>	0	PC40	<p>Same as MR-J3</p> <p>Analog monitor 2 offset</p> <p>Set the offset voltage of MO2 (Analog monitor 2).</p> <p>Setting range: -9999 to 9999 mV</p>	0	P S T
PC43	<p>For manufacturer setting</p> <p>Do not change this value by any means.</p>	0000h	PC43	<p>Error excessive alarm level</p> <p>Set an error excessive alarm level.</p> <p>You can change the setting unit with "Error excessive alarm/error excessive warning level unit selection" in [Pr. PC24].</p> <p>Set this per rev. for rotary servo motors. Setting "0" will be "3 rev", and setting over 200 rev will be clamped with 200 rev.</p> <p>Setting range: 0 to 1000</p>	0	P

Part 2: Review on Replacement of MR-J3- _A_ with MR-J4- _A_

MR-J3- _A_			MR-J4- _A_			Control mode																																							
No.	Name and function	Initial value	No.	Name and function	Initial value																																								
PD01	Input signal automatic ON selection 1 Select the input devices to be automatically turned ON.	0000h	PD01	Same as MR-J3																																									
				Input signal automatic on selection 1 Select input devices to turn on them automatically.																																									
	___x (HEX) _x__ (BIN): SON (Servo-on) 0: Disabled (Use for an external input signal.) 1: Enabled (automatic on)			___x (HEX) ___x (BIN): For manufacturer setting _x__ (BIN): For manufacturer setting _x__ (BIN): SON (Servo-on) 0: Disabled (Use for an external input signal.) 1: Enabled (automatic on)	0h		P S T																																						
				x___ (BIN): For manufacturer setting																																									
	__x_ (HEX) ___x (BIN): PC (Proportional control) 0: Disabled (Use for an external input signal.) 1: Enabled (automatic on)			__x_ (HEX) ___x (BIN): PC (Proportional control) 0: Disabled (Use for an external input signal.) 1: Enabled (automatic on)	0h		P S																																						
		__x_ (BIN): TL (External torque limit selection) 0: Disabled (Use for an external input signal.) 1: Enabled (automatic on)		P S																																									
		__x_ (BIN): TL (External torque limit selection) 0: Disabled (Use for an external input signal.) 1: Enabled (automatic on)																																											
_x__ (HEX) _x__ (BIN): LSP (Forward rotation stroke end) 0: Disabled (Use for an external input signal.) 1: Enabled (automatic on)		_x__ (HEX) _x__ (BIN): For manufacturer setting _x__ (BIN): For manufacturer setting _x__ (BIN): LSP (Forward rotation stroke end) 0: Disabled (Use for an external input signal.) 1: Enabled (automatic on)	0h	P S																																									
		x___ (BIN): LSN (Reverse rotation stroke end) 0: Disabled (Use for an external input signal.) 1: Enabled (automatic on)		P S																																									
		x___ (BIN): LSN (Reverse rotation stroke end) 0: Disabled (Use for an external input signal.) 1: Enabled (automatic on)																																											
			x___	For manufacturer setting																																									
<table border="1"> <thead> <tr> <th rowspan="2">Signal name</th> <th colspan="2">Initial value</th> </tr> <tr> <th>BIN</th> <th>HEX</th> </tr> </thead> <tbody> <tr> <td>SON (Servo-on)</td> <td>0</td> <td>0</td> </tr> <tr> <td>Proportion control (PC)</td> <td>0</td> <td>0</td> </tr> <tr> <td>External torque limit selection (TL)</td> <td>0</td> <td>0</td> </tr> <tr> <td>Forward rotation stroke end (LSP)</td> <td>0</td> <td>0</td> </tr> <tr> <td>Reverse rotation stroke end (LSN)</td> <td>0</td> <td>0</td> </tr> </tbody> </table> <p>BIN 0: Used as external input signal BIN 1: Automatic ON</p> <p>For example, to turn ON SON, the setting is "0 0 0 4".</p>			Signal name	Initial value		BIN	HEX	SON (Servo-on)	0	0	Proportion control (PC)	0	0	External torque limit selection (TL)	0	0	Forward rotation stroke end (LSP)	0	0	Reverse rotation stroke end (LSN)	0	0	<p>Convert the setting value into hexadecimal as follows.</p> <table border="1"> <thead> <tr> <th rowspan="2">Signal name</th> <th colspan="2">Initial value</th> </tr> <tr> <th>BIN</th> <th>HEX</th> </tr> </thead> <tbody> <tr> <td>SON (Servo-on)</td> <td>0</td> <td>0</td> </tr> <tr> <td>PC (Proportional control)</td> <td>0</td> <td>0</td> </tr> <tr> <td>TL (External torque limit selection)</td> <td>0</td> <td>0</td> </tr> <tr> <td>LSP (Forward rotation stroke end)</td> <td>0</td> <td>0</td> </tr> <tr> <td>LSN (Reverse rotation stroke end)</td> <td>0</td> <td>0</td> </tr> </tbody> </table> <p>BIN 0: Use for an external input signal. BIN 1: Automatic on</p>			Signal name	Initial value		BIN	HEX	SON (Servo-on)	0	0	PC (Proportional control)	0	0	TL (External torque limit selection)	0	0	LSP (Forward rotation stroke end)	0	0	LSN (Reverse rotation stroke end)	0	0
Signal name	Initial value																																												
	BIN	HEX																																											
SON (Servo-on)	0	0																																											
Proportion control (PC)	0	0																																											
External torque limit selection (TL)	0	0																																											
Forward rotation stroke end (LSP)	0	0																																											
Reverse rotation stroke end (LSN)	0	0																																											
Signal name	Initial value																																												
	BIN	HEX																																											
SON (Servo-on)	0	0																																											
PC (Proportional control)	0	0																																											
TL (External torque limit selection)	0	0																																											
LSP (Forward rotation stroke end)	0	0																																											
LSN (Reverse rotation stroke end)	0	0																																											

Part 2: Review on Replacement of MR-J3- _A_ with MR-J4- _A_

MR-J3- _A_			MR-J4- _A_																																																																																																																																																					
No.	Name and function	Initial value	No.	Name and function	Initial value	Control mode																																																																																																																																																		
PD13	<p>Output signal device selection 1 (CN1-22) Any output signal can be assigned to the CN1-22 pin. In the initial setting, INP is assigned in the position control mode, and SA is assigned in the speed control mode. Note that the device that can be assigned changes depending on the control mode.</p> <p>0 0 x x: Select the output device of the CN1-22 pin.</p> <p>The devices that can be assigned in each control mode are those that have the symbols indicated in the following table. If any other device is set, it is invalid.</p> <table border="1"> <thead> <tr> <th rowspan="2">Setting</th> <th colspan="3">Control modes (Note 1)</th> </tr> <tr> <th>P</th> <th>S</th> <th>T</th> </tr> </thead> <tbody> <tr> <td>00</td> <td>Always OFF</td> <td>Always OFF</td> <td>Always OFF</td> </tr> <tr> <td>01</td> <td colspan="3">For manufacturer setting (Note 2)</td> </tr> <tr> <td>02</td> <td>RD</td> <td>RD</td> <td>RD</td> </tr> <tr> <td>03</td> <td>ALM</td> <td>ALM</td> <td>ALM</td> </tr> <tr> <td>04</td> <td>INP</td> <td>SA</td> <td>Always OFF</td> </tr> <tr> <td>05</td> <td>MBR</td> <td>MBR</td> <td>MBR</td> </tr> <tr> <td>06</td> <td>DB</td> <td>DB</td> <td>DB</td> </tr> <tr> <td>07</td> <td>TLC</td> <td>TLC</td> <td>VLC</td> </tr> <tr> <td>08</td> <td>WNG</td> <td>WNG</td> <td>WNG</td> </tr> <tr> <td>09</td> <td>BWNG</td> <td>BWNG</td> <td>BWNG</td> </tr> <tr> <td>0A</td> <td>Always OFF</td> <td>SA</td> <td>SA</td> </tr> <tr> <td>0B</td> <td>Always OFF</td> <td>Always OFF</td> <td>VLC</td> </tr> <tr> <td>0C</td> <td>ZSP</td> <td>ZSP</td> <td>ZSP</td> </tr> <tr> <td>0D</td> <td colspan="3">For manufacturer setting (Note 2)</td> </tr> <tr> <td>0E</td> <td colspan="3">For manufacturer setting (Note 2)</td> </tr> <tr> <td>0F</td> <td>CDPS</td> <td>Always OFF</td> <td>Always OFF</td> </tr> <tr> <td>10</td> <td colspan="3">For manufacturer setting (Note 2)</td> </tr> <tr> <td>11</td> <td>ABSV</td> <td>Always OFF</td> <td>Always OFF</td> </tr> <tr> <td>12 to 3F</td> <td colspan="3">For manufacturer setting (Note 2)</td> </tr> </tbody> </table> <p>Note 1. P: Position control mode S: Speed control mode T: Torque control mode</p> <p>2. For manufacturer setting. Never set this value.</p> <p>When "Valid (ABS transfer by DI0)" has been selected for the absolute position detection system in [Pr. PA03], the CN1-22 pin is set to the ABS transmission data bit 0 (ABSB0) in the ABS transfer mode only.</p>	Setting	Control modes (Note 1)			P	S	T	00	Always OFF	Always OFF	Always OFF	01	For manufacturer setting (Note 2)			02	RD	RD	RD	03	ALM	ALM	ALM	04	INP	SA	Always OFF	05	MBR	MBR	MBR	06	DB	DB	DB	07	TLC	TLC	VLC	08	WNG	WNG	WNG	09	BWNG	BWNG	BWNG	0A	Always OFF	SA	SA	0B	Always OFF	Always OFF	VLC	0C	ZSP	ZSP	ZSP	0D	For manufacturer setting (Note 2)			0E	For manufacturer setting (Note 2)			0F	CDPS	Always OFF	Always OFF	10	For manufacturer setting (Note 2)			11	ABSV	Always OFF	Always OFF	12 to 3F	For manufacturer setting (Note 2)			0004h	PD23	<p>Output device selection 1 __ x x: Device selection Any output device can be assigned to the CN1-22 pin. When "Enabled (absolute position detection system by DIO) (__ _ 1)" is selected in [Pr. PA03], the CN1-22 pin will become ABSB0 (ABS send data bit 0) only during ABS transfer mode. Refer to table 2.8 for settings.</p> <p>_ x __: For manufacturer setting</p> <p>x __ __: For manufacturer setting</p> <table border="1"> <caption>Table 2.8 Selectable output devices</caption> <thead> <tr> <th rowspan="2">Setting value</th> <th colspan="3">Output device (Note)</th> </tr> <tr> <th>P</th> <th>S</th> <th>T</th> </tr> </thead> <tbody> <tr> <td>__ 00</td> <td>Always off</td> <td>Always off</td> <td>Always off</td> </tr> <tr> <td>__ 02</td> <td>RD</td> <td>RD</td> <td>RD</td> </tr> <tr> <td>__ 03</td> <td>ALM</td> <td>ALM</td> <td>ALM</td> </tr> <tr> <td>__ 04</td> <td>INP</td> <td>SA</td> <td>Always off</td> </tr> <tr> <td>__ 05</td> <td>MBR</td> <td>MBR</td> <td>MBR</td> </tr> <tr> <td>__ 06</td> <td>DB</td> <td>DB</td> <td>DB</td> </tr> <tr> <td>__ 07</td> <td>TLC</td> <td>TLC</td> <td>VLC</td> </tr> <tr> <td>__ 08</td> <td>WNG</td> <td>WNG</td> <td>WNG</td> </tr> <tr> <td>__ 09</td> <td>BWNG</td> <td>BWNG</td> <td>BWNG</td> </tr> <tr> <td>__ 0A</td> <td>Always off</td> <td>SA</td> <td>Always off</td> </tr> <tr> <td>__ 0B</td> <td>Always off</td> <td>Always off</td> <td>VLC</td> </tr> <tr> <td>__ 0C</td> <td>ZSP</td> <td>ZSP</td> <td>ZSP</td> </tr> <tr> <td>__ 0F</td> <td>CDPS</td> <td>Always off</td> <td>Always off</td> </tr> <tr> <td>__ 11</td> <td>ABSV</td> <td>Always off</td> <td>Always off</td> </tr> </tbody> </table> <p>Note. P: Position control mode S: Speed control mode T: Torque control mode</p>	Setting value	Output device (Note)			P	S	T	__ 00	Always off	Always off	Always off	__ 02	RD	RD	RD	__ 03	ALM	ALM	ALM	__ 04	INP	SA	Always off	__ 05	MBR	MBR	MBR	__ 06	DB	DB	DB	__ 07	TLC	TLC	VLC	__ 08	WNG	WNG	WNG	__ 09	BWNG	BWNG	BWNG	__ 0A	Always off	SA	Always off	__ 0B	Always off	Always off	VLC	__ 0C	ZSP	ZSP	ZSP	__ 0F	CDPS	Always off	Always off	__ 11	ABSV	Always off	Always off	04h	P S T
Setting	Control modes (Note 1)																																																																																																																																																							
	P	S	T																																																																																																																																																					
00	Always OFF	Always OFF	Always OFF																																																																																																																																																					
01	For manufacturer setting (Note 2)																																																																																																																																																							
02	RD	RD	RD																																																																																																																																																					
03	ALM	ALM	ALM																																																																																																																																																					
04	INP	SA	Always OFF																																																																																																																																																					
05	MBR	MBR	MBR																																																																																																																																																					
06	DB	DB	DB																																																																																																																																																					
07	TLC	TLC	VLC																																																																																																																																																					
08	WNG	WNG	WNG																																																																																																																																																					
09	BWNG	BWNG	BWNG																																																																																																																																																					
0A	Always OFF	SA	SA																																																																																																																																																					
0B	Always OFF	Always OFF	VLC																																																																																																																																																					
0C	ZSP	ZSP	ZSP																																																																																																																																																					
0D	For manufacturer setting (Note 2)																																																																																																																																																							
0E	For manufacturer setting (Note 2)																																																																																																																																																							
0F	CDPS	Always OFF	Always OFF																																																																																																																																																					
10	For manufacturer setting (Note 2)																																																																																																																																																							
11	ABSV	Always OFF	Always OFF																																																																																																																																																					
12 to 3F	For manufacturer setting (Note 2)																																																																																																																																																							
Setting value	Output device (Note)																																																																																																																																																							
	P	S	T																																																																																																																																																					
__ 00	Always off	Always off	Always off																																																																																																																																																					
__ 02	RD	RD	RD																																																																																																																																																					
__ 03	ALM	ALM	ALM																																																																																																																																																					
__ 04	INP	SA	Always off																																																																																																																																																					
__ 05	MBR	MBR	MBR																																																																																																																																																					
__ 06	DB	DB	DB																																																																																																																																																					
__ 07	TLC	TLC	VLC																																																																																																																																																					
__ 08	WNG	WNG	WNG																																																																																																																																																					
__ 09	BWNG	BWNG	BWNG																																																																																																																																																					
__ 0A	Always off	SA	Always off																																																																																																																																																					
__ 0B	Always off	Always off	VLC																																																																																																																																																					
__ 0C	ZSP	ZSP	ZSP																																																																																																																																																					
__ 0F	CDPS	Always off	Always off																																																																																																																																																					
__ 11	ABSV	Always off	Always off																																																																																																																																																					
					0h																																																																																																																																																			
					0h																																																																																																																																																			

Part 2: Review on Replacement of MR-J3- _A_ with MR-J4- _A_

MR-J3- _A_			MR-J4- _A_			Control mode	
No.	Name and function	Initial value	No.	Name and function	Initial value		
PD14	<p>Output signal device selection 2 (CN1-23) Any output signal can be assigned to the CN1-23 pin. In the initial setting, ZSP is assigned to the pin. The devices that can be assigned and the setting method are the same as in [Pr. PD13].</p> <p>0 0 x x: Select the output device of the CN1-23 pin.</p> <p>When "Valid (ABS transfer by DIO)" has been selected for the absolute position detection system in [Pr. PA13], the CN1-23 pin is set to the ABS transmission data bit 1 (ABSB1) in the ABS transfer mode only.</p>	000Ch	PD24	Same as MR-J3	0Ch	P S T	
				Output device selection 2 __ x x: Device selection Any output device can be assigned to the CN1-23 pin. When "Enabled (absolute position detection system by DIO) (___ 1)" is selected in [Pr. PA03], the CN1-23 pin will become ABSB1 (ABS send data bit 1) only during ABS transfer mode. Refer to table 2.8 in [Pr. PD23] for settings.			0h
				_ x _ : For manufacturer setting			0h
PD15	<p>Output signal device selection 3 (CN1-24) Any output signal can be assigned to the CN1-24 pin. In the initial setting, INP is assigned in the position control mode, and SA is assigned in the speed control mode. The devices that can be assigned and the setting method are the same as in [Pr. PD13].</p> <p>0 0 x x: Select the output device of the CN1-24 pin.</p>	0004h	PD25	Same setting as MR-J3	04h	P S T	
				Output device selection 3 __ x x: Device selection Any output device can be assigned to the CN1-24 pin. Refer to table 2.8 in [Pr. PD23] for settings.			0h
				_ x _ : For manufacturer setting			0h
PD16	<p>Output signal device selection 4 (CN1-25) Any output signal can be assigned to the CN1-25 pin. In the initial setting, TLC is assigned in the position control and speed control modes, and VLC is assigned in the torque control mode. The devices that can be assigned and the setting method are the same as in [Pr. PD13].</p> <p>0 0 x x: Select the output device of the CN1-25 pin. When "Valid (ABS transfer by DIO)" has been selected for the absolute position detection system in [Pr. PA03], the CN1-25 pin is set to the ABS transmission data ready (ABST) in the ABS transfer mode only.</p>	0007h	PD26	Same setting as MR-J3	07h	P S T	
				Output device selection 4 __ x x: Device selection Any output device can be assigned to the CN1-25 pin. When "Enabled (absolute position detection system by DIO) (___ 1)" is selected in [Pr. PA03], the CN1-25 pin will become ABST (ABS send data ready) only during ABS transfer mode. Refer to table 2.8 in [Pr. PD23] for settings.			0h
				x _ _ : For manufacturer setting			0h
PD18	<p>Output signal device selection 6 (CN1-49) Any output signal can be assigned to the CN1-49 pin. In the initial setting, RD is assigned to the pin. The devices that can be assigned and the setting method are the same as in [Pr. PD13].</p> <p>0 0 x x: Select the output device of the CN1-49 pin.</p>	0002h	PD28	Same setting as MR-J3	02h	P S T	
				Output device selection 6 __ x x: Device selection Any output device can be assigned to the CN1-49 pin. Refer to table 2.8 in [Pr. PD23] for settings.			0h
				_ x _ : For manufacturer setting			0h
				x _ _ : For manufacturer setting	0h		

Part 2: Review on Replacement of MR-J3-__A__ with MR-J4-__A__

MR-J3-__A__			MR-J4-__A__			
No.	Name and function	Initial value	No.	Name and function	Initial value	Control mode
PD19	<p>Input filter setting Select the input filter.</p> <p>0 0 0 x: Input signal filter If external input signal causes chattering due to noise, etc., input filter is used to suppress it.</p> <p>0: None 1: 1.777 [ms] 2: 3.555 [ms] 3: 5.333 [ms]</p>	0002h	PD29	<p>Input filter setting Select a filter for the input signal.</p> <p>___x: Input signal filter selection If external input signal causes chattering due to noise, etc., input filter is used to suppress it.</p> <p>0: None 1: 0.888 [ms] 2: 1.777 [ms] 3: 2.666 [ms] 4: 3.555 [ms]</p>	4h	P S T
			<p>__x_: RES (Reset) dedicated filter selection</p> <p>0: Disabled 1: Enabled (50 [ms])</p>	0h	P S T	
			<p>_x_ _: CR (Clear) dedicated filter selection</p> <p>0: Disabled 1: Enabled (50 [ms])</p>	0h	P S T	
			<p>x _ _ _: For manufacturer setting</p>	0h		
PD20	<p>Function selection D-1 Select the stop processing at forward rotation stroke end (LSP)/reverse rotation stroke end (LSN) OFF and the base circuit status at reset (RES) ON.</p> <p>0 0 _x: How to make a stop when forward rotation stroke end (LSP) reverse rotation stroke end (LSN) is valid.</p> <p>0: Sudden stop 1: Slow stop</p> <p>0 0 x _: Selection of base circuit status at reset (RES) ON</p> <p>0: Base circuit switched off 1: Base circuit not switched off</p>	0000h	PD30	<p>Function selection D-1 ___x: Stop method selection for LSP (Forward rotation stroke end) off and LSN (Reverse rotation stroke end) off</p> <p>Select a stop method for LSP (Forward rotation stroke end) off and LSN (Reverse rotation stroke end) off. Setting "2" or "3" will trigger [AL. 37 Parameter error] in the mode other than the positioning mode.</p> <p>0: Quick stop 1: Slow stop</p>	0h	P S
			<p>__x_: Base circuit status selection for RES (Reset) on</p> <p>0: Base circuit shut-off 1: No base circuit shut-off</p>	0h	P S T	
			<p>_x_ _: For manufacturer setting</p>	0h		
			<p>x _ _ _: Enabled/disabled selection for a thermistor of servo motor</p> <p>0: Enabled 1: Disabled</p> <p>The setting in this digit will be disabled when using a servo motor without thermistor. This parameter is used by servo amplifier with software version A5 or later.</p>	0h	P S T	

Part 2: Review on Replacement of MR-J3-__A__ with MR-J4-__A__

MR-J3-__A__			MR-J4-__A__			Control mode
No.	Name and function	Initial value	No.	Name and function	Initial value	
PD21	For manufacturer setting Do not change this value by any means.	0000h	PD31	Function selection D-2 ____x:	0h	/
				For manufacturer setting		
				__x_:	0h	
				For manufacturer setting		
PD22	Function selection D-3 Set the clear (CR). 0 0 0 x: Clear (CR) selection 0: Droop pulses are cleared on the leading edge. 1: While on, droop pulses are always cleared.	0000h	PD32	Same setting as MR-J3	0h	P
				Function selection D-3 ____x: CR (Clear) selection Set CR (Clear). 0: Deleting droop pulses at the leading edge of turning on of CR 1: Continuous deleting of droop pulses while CR is on 2: Disabled (available for the software version B3 or later)		
				__x_:	0h	
				For manufacturer setting		
PD23	For manufacturer setting Do not change this value by any means.	0000h	PD33	____x: For manufacturer setting	0h	/
				__x_:	0h	
				For manufacturer setting		
				Function selection D-4 _x_: Rotation direction selection for enabling torque limit Select a direction which enables internal torque limit 2 or external torque limit. 0: Both of "CCW" and "CW" are enabled. 1: Enabled with "CCW" 2: Enabled with "CW" This parameter setting is used with servo amplifier with software version B3 or later.	0h	
x_:	0h					
For manufacturer setting						

Part 2: Review on Replacement of MR-J3- _A_ with MR-J4- _A_

MR-J3- _A_			MR-J4- _A_			Control mode																																																																																																																																																															
No.	Name and function	Initial value	No.	Name and function	Initial value																																																																																																																																																																
PD24	<p>Function selection D-5</p> <p>0 0 _ x:</p> <p>Setting of alarm code output</p> <p>Select the alarm code and warning (WNG) outputs.</p> <table border="1"> <thead> <tr> <th rowspan="2">Set value</th> <th colspan="3">Connector pins of CN1</th> </tr> <tr> <th>22</th> <th>23</th> <th>24</th> </tr> </thead> <tbody> <tr> <td>0</td> <td colspan="3">Alarm code is not output</td> </tr> <tr> <td>1</td> <td colspan="3">Alarm code is output at alarm occurrence.</td> </tr> </tbody> </table> <table border="1"> <thead> <tr> <th colspan="3">Alarm code (Note)</th> <th rowspan="2">Alarm display</th> <th rowspan="2">Name</th> </tr> <tr> <th>CN1-22</th> <th>CN1-23</th> <th>CN1-24</th> </tr> </thead> <tbody> <tr> <td>0</td> <td>0</td> <td>0</td> <td>88888</td> <td>Watchdog</td> </tr> <tr> <td></td> <td></td> <td></td> <td>AL.12</td> <td>Memory error 1</td> </tr> <tr> <td></td> <td></td> <td></td> <td>AL.13</td> <td>Clock error</td> </tr> <tr> <td></td> <td></td> <td></td> <td>AL.15</td> <td>Memory error 2</td> </tr> <tr> <td></td> <td></td> <td></td> <td>AL.17</td> <td>Board error</td> </tr> <tr> <td></td> <td></td> <td></td> <td>AL.19</td> <td>Memory error 3</td> </tr> <tr> <td></td> <td></td> <td></td> <td>AL.37</td> <td>Parameter error</td> </tr> <tr> <td></td> <td></td> <td></td> <td>AL.8A</td> <td>Serial communication time-out error</td> </tr> <tr> <td></td> <td></td> <td></td> <td>AL.8E</td> <td>Serial communication error</td> </tr> <tr> <td>0</td> <td>0</td> <td>1</td> <td>AL.30</td> <td>Regenerative error</td> </tr> <tr> <td></td> <td></td> <td></td> <td>AL.33</td> <td>Overvoltage</td> </tr> <tr> <td>0</td> <td>1</td> <td>0</td> <td>AL.10</td> <td>Undervoltage</td> </tr> <tr> <td>0</td> <td>1</td> <td>1</td> <td>AL.45</td> <td>Main circuit device overheat</td> </tr> <tr> <td></td> <td></td> <td></td> <td>AL.46</td> <td>Servo motor overheat</td> </tr> <tr> <td></td> <td></td> <td></td> <td>AL.47</td> <td>Cooling fan alarm</td> </tr> <tr> <td></td> <td></td> <td></td> <td>AL.50</td> <td>Overload 1</td> </tr> <tr> <td></td> <td></td> <td></td> <td>AL.51</td> <td>Overload 2</td> </tr> <tr> <td>1</td> <td>0</td> <td>0</td> <td>AL.24</td> <td>Main circuit</td> </tr> <tr> <td></td> <td></td> <td></td> <td>AL.32</td> <td>Overcurrent</td> </tr> <tr> <td>1</td> <td>0</td> <td>1</td> <td>AL.31</td> <td>Overspeed</td> </tr> <tr> <td></td> <td></td> <td></td> <td>AL.35</td> <td>Command pulse frequency error</td> </tr> <tr> <td></td> <td></td> <td></td> <td>AL.52</td> <td>Error excessive</td> </tr> <tr> <td>1</td> <td>1</td> <td>0</td> <td>AL.16</td> <td>Encoder error 1</td> </tr> <tr> <td></td> <td></td> <td></td> <td>AL.1A</td> <td>Motor combination error</td> </tr> <tr> <td></td> <td></td> <td></td> <td>AL.20</td> <td>Encoder error 2</td> </tr> <tr> <td></td> <td></td> <td></td> <td>AL.25</td> <td>Absolute position erase</td> </tr> </tbody> </table> <p>Note 0: off 1: on</p> <p>A parameter alarm [AL. 37 Parameter error] occurs if the alarm code output is selected with [Pr. PA03] set to " _ _ _ 1" and the DI0-based absolute position detection system selected.</p>	Set value	Connector pins of CN1			22	23	24	0	Alarm code is not output			1	Alarm code is output at alarm occurrence.			Alarm code (Note)			Alarm display	Name	CN1-22	CN1-23	CN1-24	0	0	0	88888	Watchdog				AL.12	Memory error 1				AL.13	Clock error				AL.15	Memory error 2				AL.17	Board error				AL.19	Memory error 3				AL.37	Parameter error				AL.8A	Serial communication time-out error				AL.8E	Serial communication error	0	0	1	AL.30	Regenerative error				AL.33	Overvoltage	0	1	0	AL.10	Undervoltage	0	1	1	AL.45	Main circuit device overheat				AL.46	Servo motor overheat				AL.47	Cooling fan alarm				AL.50	Overload 1				AL.51	Overload 2	1	0	0	AL.24	Main circuit				AL.32	Overcurrent	1	0	1	AL.31	Overspeed				AL.35	Command pulse frequency error				AL.52	Error excessive	1	1	0	AL.16	Encoder error 1				AL.1A	Motor combination error				AL.20	Encoder error 2				AL.25	Absolute position erase	0000h	PD34	<p>Function selection D-5</p> <p>_ _ _ x:</p> <p>Alarm code output</p> <p>Select output status of alarm codes.</p> <p>Alarm codes are outputted to the pins CN1-22, CN1-23, and CN1-24.</p> <p>0: Disabled 1: Enabled</p> <p>When "Enabled (absolute position detection system by DIO) (_ _ _ 1)" is selected in [Pr. PA03] and when MBR (Electromagnetic brake interlock) or ALM (Malfunction) is assigned to the CN1-22 pin, CN1-23 pin, or CN1-24 pin, selecting alarm code output will generate [AL. Parameter error]. (The alarm code output is different from that for MR-J3. Refer to the "MR-J4- _A_ (-RJ)/MR-J4-03A6(-RJ) Servo Amplifier Instruction Manual".)</p> <p>_ _ x _ :</p> <p>Selection of output device at warning occurrence</p> <p>Select ALM (Malfunction) output status at warning occurrence.</p> <table border="1"> <thead> <tr> <th>Setting value</th> <th>Device status</th> </tr> </thead> <tbody> <tr> <td>0</td> <td> <p>WNG ON OFF</p> <p>ALM ON OFF</p> <p>Warning occurrence</p> </td> </tr> <tr> <td>1</td> <td> <p>WNG ON OFF</p> <p>ALM ON OFF</p> <p>Warning occurrence</p> </td> </tr> </tbody> </table>	Setting value	Device status	0	<p>WNG ON OFF</p> <p>ALM ON OFF</p> <p>Warning occurrence</p>	1	<p>WNG ON OFF</p> <p>ALM ON OFF</p> <p>Warning occurrence</p>	0h	P S T
Set value	Connector pins of CN1																																																																																																																																																																				
	22	23	24																																																																																																																																																																		
0	Alarm code is not output																																																																																																																																																																				
1	Alarm code is output at alarm occurrence.																																																																																																																																																																				
Alarm code (Note)			Alarm display	Name																																																																																																																																																																	
CN1-22	CN1-23	CN1-24																																																																																																																																																																			
0	0	0	88888	Watchdog																																																																																																																																																																	
			AL.12	Memory error 1																																																																																																																																																																	
			AL.13	Clock error																																																																																																																																																																	
			AL.15	Memory error 2																																																																																																																																																																	
			AL.17	Board error																																																																																																																																																																	
			AL.19	Memory error 3																																																																																																																																																																	
			AL.37	Parameter error																																																																																																																																																																	
			AL.8A	Serial communication time-out error																																																																																																																																																																	
			AL.8E	Serial communication error																																																																																																																																																																	
0	0	1	AL.30	Regenerative error																																																																																																																																																																	
			AL.33	Overvoltage																																																																																																																																																																	
0	1	0	AL.10	Undervoltage																																																																																																																																																																	
0	1	1	AL.45	Main circuit device overheat																																																																																																																																																																	
			AL.46	Servo motor overheat																																																																																																																																																																	
			AL.47	Cooling fan alarm																																																																																																																																																																	
			AL.50	Overload 1																																																																																																																																																																	
			AL.51	Overload 2																																																																																																																																																																	
1	0	0	AL.24	Main circuit																																																																																																																																																																	
			AL.32	Overcurrent																																																																																																																																																																	
1	0	1	AL.31	Overspeed																																																																																																																																																																	
			AL.35	Command pulse frequency error																																																																																																																																																																	
			AL.52	Error excessive																																																																																																																																																																	
1	1	0	AL.16	Encoder error 1																																																																																																																																																																	
			AL.1A	Motor combination error																																																																																																																																																																	
			AL.20	Encoder error 2																																																																																																																																																																	
			AL.25	Absolute position erase																																																																																																																																																																	
Setting value	Device status																																																																																																																																																																				
0	<p>WNG ON OFF</p> <p>ALM ON OFF</p> <p>Warning occurrence</p>																																																																																																																																																																				
1	<p>WNG ON OFF</p> <p>ALM ON OFF</p> <p>Warning occurrence</p>																																																																																																																																																																				
					0h	P S T																																																																																																																																																															
				_ x _ _ :	0h																																																																																																																																																																
				For manufacturer setting																																																																																																																																																																	
				x _ _ _ :	0h																																																																																																																																																																
				For manufacturer setting																																																																																																																																																																	
	<p>0 0 x _ :</p> <p>Selection of output device at warning occurrence</p> <p>Select the warning (WNG) and trouble (ALM) output status at warning occurrence.</p> <table border="1"> <thead> <tr> <th>Setting</th> <th>Device status</th> </tr> </thead> <tbody> <tr> <td>0</td> <td> <p>WNG 1 0</p> <p>ALM 1 0</p> <p>Warning occurrence</p> </td> </tr> <tr> <td>1</td> <td> <p>WNG 1 0</p> <p>ALM 1 0</p> <p>Warning occurrence</p> </td> </tr> </tbody> </table> <p>Note 0: off 1: on</p>	Setting	Device status	0	<p>WNG 1 0</p> <p>ALM 1 0</p> <p>Warning occurrence</p>	1	<p>WNG 1 0</p> <p>ALM 1 0</p> <p>Warning occurrence</p>																																																																																																																																																														
Setting	Device status																																																																																																																																																																				
0	<p>WNG 1 0</p> <p>ALM 1 0</p> <p>Warning occurrence</p>																																																																																																																																																																				
1	<p>WNG 1 0</p> <p>ALM 1 0</p> <p>Warning occurrence</p>																																																																																																																																																																				

Part 2: Review on Replacement of MR-J3- _A_ with MR-J4- _A_

3.6 Important Points for Replacement

1. SUMMARY

This section describes the precautions for setting parameters for the replacement of MR-J3- _A_ with MR-J4- _A_. For details on the parameters of MR-J3- _A_, refer to "MR-J3- _A_ Servo Amplifier Instruction Manual".

2. Precautions

We recommend that you use the parameter converter function (supported from version 1.12N or later) of MR Configurator2 for the replacement of MR-J3- _A_ with MR-J4- _A_. The following describes the parameters that are easily missed when the parameter setting is manually changed.

(1) Command input pulse train filter selection (_ x _) of [Pr. PA13 Command pulse input form]

As compared to MR-J3- _A_, the command input pulse train filter selection is added in [Pr.PA13] of MR-J4- _A_. Do not set "0h" for the command input pulse train filter selection when changing the command input pulse train form selection and pulse train logic selection. Setting "0h" for the command input pulse train filter selection enables the command input of up to 4 Mpulses/s but reduces the noise filter ability.

POINT
●Set "pulse train form" of the pulse output function correctly.

No./symbol/ name	Setting digit	Function	Initial value [unit]	Control mode (O:Enabled)		
				P	S	T
PA13 *PLSS Command pulse input form	___x	Command input pulse train form selection 0: Forward/reverse rotation pulse train 1: Signed pulse train 2: A-phase/B-phase pulse train	0h	○		
	__x_	Pulse train logic selection 0: Positive logic 1: Negative logic	0h	○		
	_x__	Command input pulse train filter selection Selecting proper filter enables to enhance noise tolerance. 0: Command input pulse train is 4 Mpulses/s or less. 1: Command input pulse train is 1 Mpulse/s or less. 2: Command input pulse train is 500 kpulses/s or less. 3: Command input pulse train is 200 kpulses/s or less (available for the software version A5 or later) 1 Mpulse/s or lower commands are supported by "1". When inputting commands over 1 Mpulse/s and 4 Mpulses/s or lower, set "0".	1h	○		
	x___	For manufacturer setting	0h			

Part 2: Review on Replacement of MR-J3-__A__ with MR-J4-__A__

(2) [Pr. PC16 Electromagnetic brake sequence output]

MR-J3-__A__ and MR-J4-__A__ have different initial values for [Pr. PC16] (MR-J3-__A__ : 100 ms, MR-J4-__A__ : 0 ms). When MBR (Electromagnetic brake interlock) is assigned for [Pr. PD23] to [Pr. PD26] and [Pr. PD28], refer to the "MR-J4-__A__(-RJ)/MR-J4-03A6(-RJ) Servo Amplifier Instruction Manual" and then set [Pr. PC16].

No./symbol/ name	Setting digit	Function	Initial value [unit]	Control mode (O: Enabled)		
				P	S	T
PC16 MBR Electromagnetic brake sequence output		Set the delay time between MBR (Electromagnetic brake interlock) and the base drive circuit is shut-off. Setting range: 0 to 1000	0 [ms]	<input type="radio"/>	<input type="radio"/>	<input type="radio"/>

(3) Input signal filter selection (___x) of [Pr. PD29 Input filter setting]

MR-J3-__A__ and MR-J4-__A__ have different initial values for the input signal filter selection.

No./symbol/ name	Setting digit	Function	Initial value [unit]	Control mode (O: Enabled)																				
				P	S	T																		
PD29 *DIF Input filter setting		Select a filter for the input signal.																						
	___x	Input signal filter selection If external input signal causes chattering due to noise, etc., input filter is used to suppress it.	4h	<input type="radio"/>	<input type="radio"/>	<input type="radio"/>																		
		<table border="1"> <thead> <tr> <th>Setting value</th> <th>MR-J3-__A__</th> <th>MR-J4-__A__</th> </tr> </thead> <tbody> <tr> <td>0</td> <td>None</td> <td>None</td> </tr> <tr> <td>1</td> <td>1.777 [ms]</td> <td>0.888 [ms]</td> </tr> <tr> <td>2</td> <td>3.555 [ms] (Initial value)</td> <td>1.777 [ms]</td> </tr> <tr> <td>3</td> <td>5.333 [ms]</td> <td>2.666 [ms]</td> </tr> <tr> <td>4</td> <td></td> <td>3.555 [ms] (Initial value)</td> </tr> </tbody> </table>	Setting value	MR-J3-__A__	MR-J4-__A__	0	None	None	1	1.777 [ms]	0.888 [ms]	2	3.555 [ms] (Initial value)	1.777 [ms]	3	5.333 [ms]	2.666 [ms]	4		3.555 [ms] (Initial value)				
Setting value	MR-J3-__A__	MR-J4-__A__																						
0	None	None																						
1	1.777 [ms]	0.888 [ms]																						
2	3.555 [ms] (Initial value)	1.777 [ms]																						
3	5.333 [ms]	2.666 [ms]																						
4		3.555 [ms] (Initial value)																						
	__x_	RES (Reset) dedicated filter selection 0: Disabled 1: Enabled (50 [ms])	0h	<input type="radio"/>	<input type="radio"/>	<input type="radio"/>																		
	_x__	CR (Clear) dedicated filter selection 0: Disabled 1: Enabled (50 [ms])	0h	<input type="radio"/>	<input type="radio"/>	<input type="radio"/>																		
	x___	For manufacturer setting	0h	<input type="radio"/>	<input type="radio"/>	<input type="radio"/>																		

Part 3

Review on Replacement of

MR-J3- _B_ with MR-J4- _B_

Part 3: Review on Replacement of MR-J3-_B_ with MR-J4-_B_

Part 3: Review on Replacement of MR-J3-_B_ with MR-J4-_B_

1. SUMMARY

This document describes the changes that are applied to when replacing a system using the MR-J3-_B_ with a system using the MR-J4-_B_.

2. CASE STUDY ON REPLACEMENT OF MR-J3-_B_

2.1 Review on Replacement Method

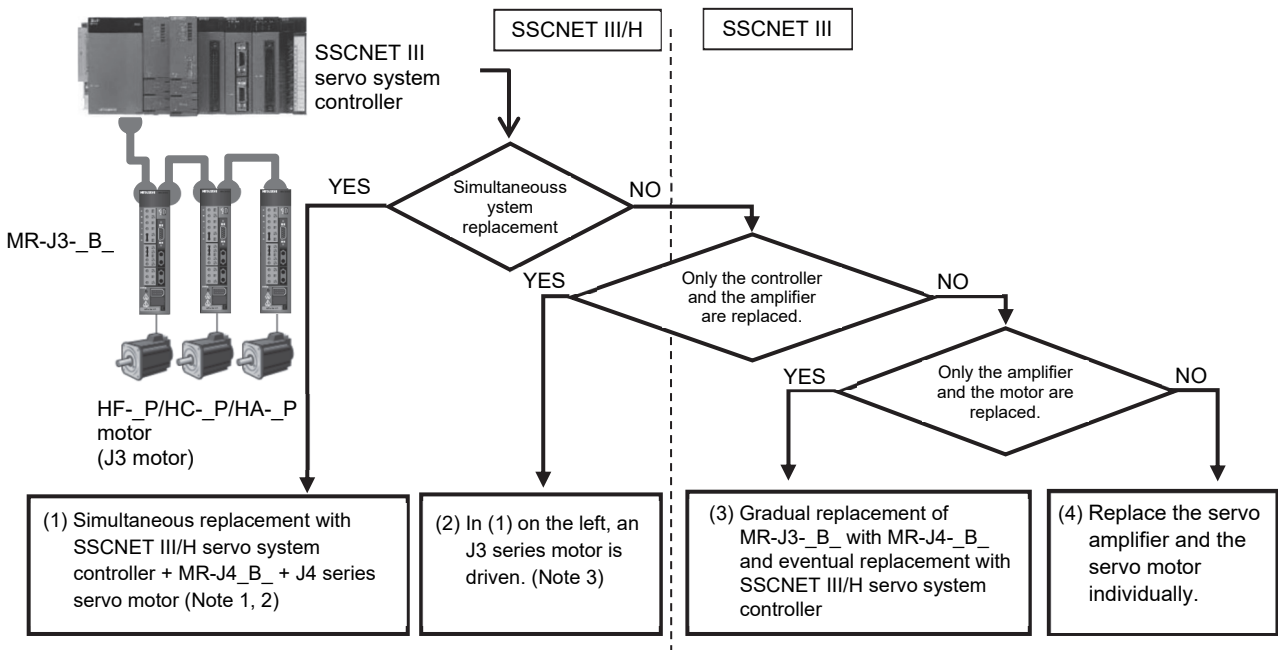

- Note
1. Although heavier burdens including a longer construction period need to be borne, once replaced the system can be operated for a long period of time.
 2. When designing a new system, apply simultaneous replacement at (1).
 3. Replacing the system allows some J3 series servo motors to drive in MR-J4-_B_ (J4 mode) and MR-J4-_B_ (J3 compatibility mode). Check "Part 8: Common Reference Material" for target motors.

Part 3: Review on Replacement of MR-J3-_B_ with MR-J4-_B_

2.2 Replacement Method

This section shows replacements using a QDS motion controller and an SSCNETIII/H stand-alone motion controller as examples.

(1) For simultaneous replacement

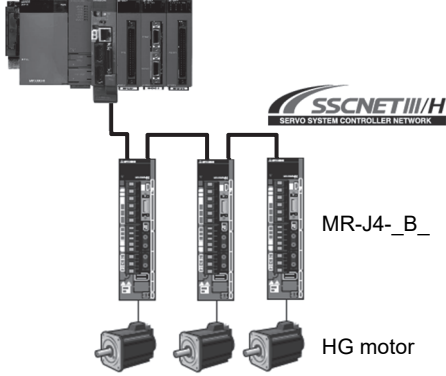
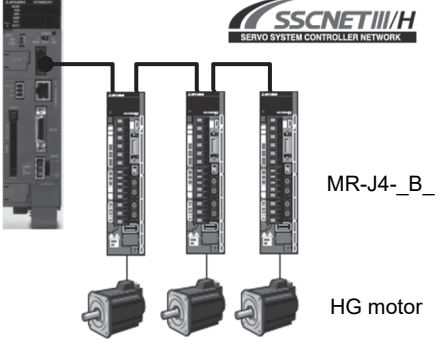
QDS motion controller + MR-J4-_B_ + HG motor	Stand-alone motion controller + MR-J4-_B_ + HG motor
<p>QnUD(E)(H)CPU + QDS motion controller + Q3_DB</p>  <p>SSCNET III/H SERVO SYSTEM CONTROLLER NETWORK</p> <p>MR-J4-_B_</p> <p>HG motor</p> <p>High-speed motion control and excellent extensibility can reduce cycle time.</p>	<p>SSCNET III/H stand-alone motion controller Q170MSCPU(-S1)</p>  <p>SSCNET III/H SERVO SYSTEM CONTROLLER NETWORK</p> <p>MR-J4-_B_</p> <p>HG motor</p> <p>High performance equivalent to that of a QDS motion controller can be achieved at a lower cost.</p>

"QDS motion controller" refers to the following model.

- Q172DSCPU
- Q173DSCPU

"Stand-alone motion controller" refers to the following model.

- Q170MSCPU(-S1)

(2) For replacement of a controller and a servo amplifier

Replacing the system allows some J3 series servo motors to drive in MR-J4-_B_ (J4 mode).

For J3 series servo motors which are available with this, check "Part 8: Common Reference Material".

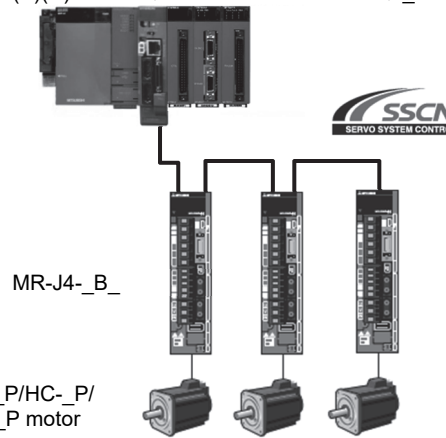
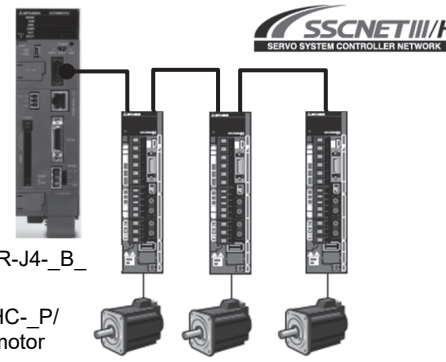
QDS motion controller + MR-J4-_B_ + HC-_FS/HA-_FS motor	Stand-alone motion controller + MR-J4-_B_ + HC-_FS/HA-_FS motor
<p>QnUD(E)(H)CPU + QDS motion controller + Q3_DB</p>  <p>SSCNET III/H SERVO SYSTEM CONTROLLER NETWORK</p> <p>MR-J4-_B_</p> <p>HF-_P/HC-_P/ HA-_P motor</p>	<p>SSCNET III/H stand-alone motion controller Q170MSCPU(-S1)</p>  <p>SSCNET III/H SERVO SYSTEM CONTROLLER NETWORK</p> <p>MR-J4-_B_</p> <p>HF-_P/HC-_P/ HA-_P motor</p>

"QDS motion controller" refers to the following model.

- Q172DSCPU
- Q173DSCPU

"Stand-alone motion controller" refers to the following model.

- Q170MSCPU(-S1)

Note. When designing a new system, please consider simultaneous replacement.

Part 3: Review on Replacement of MR-J3-_B_ with MR-J4-_B_

POINT			
<ul style="list-style-type: none"> ● MR-J3-_B_ cannot drive an HG motor. When the servo motor is replaced with an HG motor, simultaneous replacement with MR-J4-_B_ and an HG motor is necessary. ● If the existing system is any of the combinations in the following table, it is recommended to replace both the servo amplifier and servo motor with an MR-J4-_B_ and HG motor at the same time. When an HG motor is adopted, the capacity of the servo amplifier needs to be changed. (Consider replacement, referring to "torque characteristics" described in "Part 9: Replacement of Motor".) ● The low inertia "HG-JR motor" is recommended for the replacement of "HC-LP motor". <p>To use a servo motor other than the servo motors listed in following table, check the compatibility with the equipment because the motor inertia, etc. is different.</p>			
Existing device models		Replacement models for simultaneous replacement (example)	
Servo motor	Servo amplifier	Servo motor	Servo amplifier
HC-RP103(B)G5 1/_	MR-J3-200B(N)(-RT)	HG-SR102(B)G5 1/_	MR-J4-100B
HC-RP203(B)G5 1/_	MR-J3-350B	HG-SR202(B)G5 1/_	MR-J4-200B
HC-RP353(B)G5 1/_	MR-J3-500B	HG-SR352(B)G5 1/_	MR-J4-350B
HC-RP103(B)G7 1/_	MR-J3-200B(N)(-RT)	HG-SR102(B)G7 1/_	MR-J4-100B
HC-RP203(B)G7 1/_	MR-J3-350B	HG-SR202(B)G7 1/_	MR-J4-200B
HC-RP353(B)G7 1/_	MR-J3-500B	HG-SR352(B)G7 1/_	MR-J4-350B
HC-LP52(B)	MR-J3-60B	HG-JR73(B)	MR-J4-70B
HC-LP102(B)	MR-J3-100B	HG-JR153(B)	MR-J4-200B
HC-LP152(B)	MR-J3-200B(N)(-RT)	HG-JR353(B)	MR-J4-350B

(3) Gradual replacement of MR-J3-_B_ with MR-J4-_B_

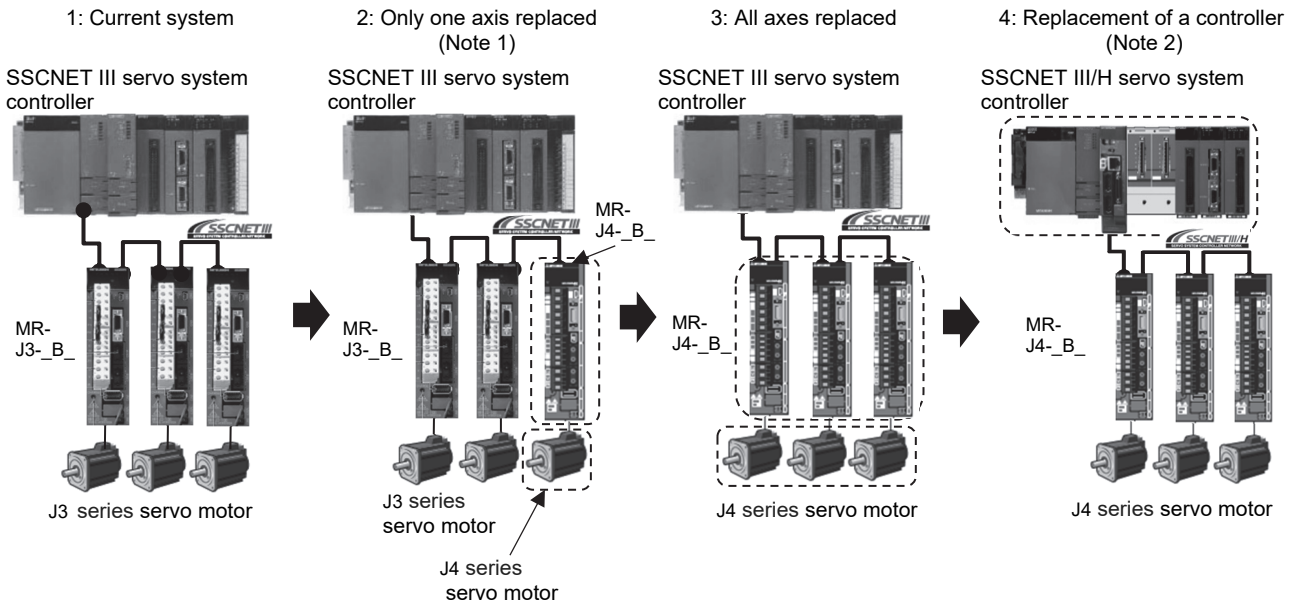

Note 1. The MR-J4-_B_ series has "J3 compatibility mode". MR-J4-_B_ and MR-J3-_B_ servo amplifiers can be used together.

Optical fiber cables for the conventional SSCNET III can be used as they are.

2. Change the settings of the MR-J4-_B_ servo amplifier to "J4 mode" using the application software "MR Mode Change" (*1).

The servo amplifiers and servo motors can be used as they are.

(*1): The application software is available with MR Configurator2 version 1.12N or later.

Part 3: Review on Replacement of MR-J3-__B__ with MR-J4-__B__

(4) For separate repair (Note)

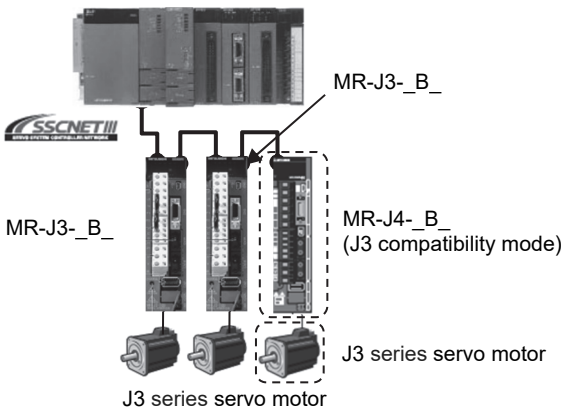
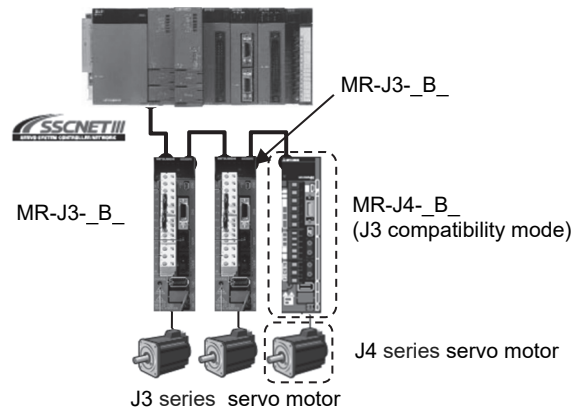
Replacement of Servo amplifier (MR-J3-__B__)	Replacement of J3 series servo motor (HC/HA)
<p>SSCNET III servo system controller</p>  <p>MR-J3-__B__</p> <p>MR-J3-__B__</p> <p>MR-J4-__B__ (J3 compatibility mode)</p> <p>J3 series servo motor</p> <p>J3 series servo motor</p> <ul style="list-style-type: none"> • J3 series servo motor driving with MR-J4-__B__ servo amplifiers (J3 compatibility mode) will be sequentially available. Refer to "Part 8: Common Reference Material" for target motors. 	<p>SSCNET III servo system controller</p>  <p>MR-J3-__B__</p> <p>MR-J3-__B__</p> <p>MR-J4-__B__ (J3 compatibility mode)</p> <p>J4 series servo motor</p> <p>J3 series servo motor</p> <ul style="list-style-type: none"> • The J4 series servo motor cannot be driven by the MR-J3-__B__ servo amplifier. Replace the existing servo amplifier and servo motor with MR-J4-__B__ servo amplifier (J3 compatibility mode) and J4 series servo motor simultaneously.

Note. Separate repair means replacement.

Part 3: Review on Replacement of MR-J3-_B_ with MR-J4-_B_

3. DIFFERENCES BETWEEN MR-J3-_B_ AND MR-J4-_B_

3.1 Function Comparison Table

POINT
● Functions with difference are shown with shading.

(1) 200 V Class

Item	MR-J3-_B_ series	MR-J4-_B_ series
1	Capacity range	0.1 kW to 22 kW/200 V
2	Internal regenerative resistor	Built-in (0.2 kW to 7 kW) External (11kW to 22 kW)
3	Dynamic brake	Built-in (0.1kW to 7kW) External (11kW to 22 kW) Coasting distance may differ. (Note 1)
4	Control circuit power	1-phase 200 V AC to 230 V AC
5	Main circuit power	1-phase 200 V AC to 230 V AC (0.1 kW to 0.75 kW) 3-phase 200 V AC to 230 V AC (0.1 kW to 22 kW)
6	24 V DC power	External supply required
7	Auto Tuning	Real-time auto tuning: 32 steps Advanced gain search
8	Control mode	Real-time auto tuning: 40 steps One-touch tuning
9	The number of DIO points (excluding EM1)	DI: 3 points, DO: 3 points
10	Encoder pulse output	ABZ-phase (differential line driver)
11	DIO interface	input/output: sink/source
12	Analog input/output	(Output) 10-bit or equivalent × 2ch
13	Parameter setting method	Setup software (SETUP221E) MR Configurator2
14	Setup software communication function	USB
15	Servo motor (Encoder resolution)	HF-_P_ series (18-bit ABS) HA-_P_ series (18-bit ABS)
16	Motor maximum torque	HF-KP 350% HF-MP 300% HF-SP 300% HF-JP 300% HA-LP 250%
17	LED display	7-segment 3-digit
18	Advanced vibration suppression control	Provided (advanced vibration suppression control II)
19	Adaptive filter II	Provided
20	Notch filter	Provided (2 pcs)
21	Tough drive	Unprovided
22	Drive recorder	Unprovided
23	Forced stop	EM1 (DB stop)

- Note 1. For the coasting distance, refer to "1.2.3 Dynamic brake: coasting distance" in "Part 8: Common Reference Material".
 2. If using a 1-phase 200 V AC to 240 V AC power supply with a 1 kW/2 kW servo amplifier, operate the servo amplifier at 75% or less of the effective load ratio.

Part 3: Review on Replacement of MR-J3-_B_ with MR-J4-_B_

(2) 400 V Class

Item		MR-J3-_B_ series	MR-J4-_B_ series
1	Capacity range	0.6 kW to 22 kW/400 V	0.6 kW to 22 kW/400 V
2	Internal regenerative resistor	Built-in (0.6 kW to 7 kW) External (11kW to 22 kW)	Built-in (0.6 kW to 7 kW) External (11kW to 22 kW)
3	Dynamic brake	Built-in (0.6 kW to 7 kW) External (11kW to 22 kW)	Built-in (0.6 kW to 7 kW) External (11kW to 22 kW) Coasting distance may differ. (Note)
4	Control circuit power	1-phase 380 V AC to 480 V AC	1-phase 380 V AC to 480 V AC
5	Main circuit power	3-phase 380 V AC to 480 V AC	3-phase 380 V AC to 480 V AC
6	24 V DC power	External supply required	External supply required
7	Auto Tuning	Real-time auto tuning: 32 steps Advanced gain search	Real-time auto tuning: 40 steps One-touch tuning
8	Control mode	SSCNET III interface (50 Mbps) ▪ Position control mode ▪ Speed control mode	SSCNET III/H interface (150 Mbps) ▪ Position control mode ▪ Speed control mode ▪ Torque control mode
			< J3 compatibility mode > SSCNET III interface (50 Mbps) ▪ Position control mode ▪ Speed control mode
9	The number of DIO points (excluding EM1)	DI: 3 points, DO: 3 points	DI: 3 points, DO: 3 points
10	Encoder pulse output	ABZ-phase (differential line driver)	ABZ-phase (differential line driver)
11	DIO interface	input/output: sink/source	input/output: sink/source
12	Analog input/output	(Output) 10-bit or equivalent × 2ch	(Output) 10-bit or equivalent × 2ch
13	Parameter setting method	Setup software (SETUP221E) MR Configurator2	MR Configurator2
14	Setup software communication function	USB	USB
15	Servo motor (Encoder resolution)	HF-_P series (18-bit ABS) HA-_P series (18-bit ABS)	HG series (22-bit ABS)
16	Motor maximum torque	HF-SP 300%	HG-SR 300%
		HF-JP 300%	HG-JR 300%
		HA-LP 250%	HG-JR 300%
17	LED display	7-segment 3-digit	7-segment 3-digit
18	Advanced vibration suppression control	Provided	Provided (Advanced vibration suppression control II)
19	Adaptive filter II	Provided	Provided

Note. For the coasting distance, refer to "1.2.3 Dynamic brake: coasting distance" in "Part 8: Common Reference Material".

Part 3: Review on Replacement of MR-J3-_B_ with MR-J4-_B_

(3) 100 V Class

Item		MR-J3-_B_ series	MR-J4-_B_ series
1	Capacity range	0.1 to 0.4 kW/100 V	0.1 to 0.4 kW/100 V
2	Internal regenerative resistor	None (0.1 kW) Built-in (0.2, 0.4 kW)	None (0.1 kW) Built-in (0.2, 0.4 kW)
3	Dynamic brake	Built-in (0.1 to 0.4 kW)	Built-in (0.1 to 0.4 kW) Coasting distance may differ. (Note)
4	Control circuit power	1-phase AC 100 to 120 V	1-phase AC 100 to 120 V
5	Main circuit power	1-phase AC 100 to 120 V (0.1 to 0.4 kW)	1-phase AC 100 to 120 V (0.1 to 0.4 kW)
6	24 V DC power	External supply required	External supply required
7	Auto Tuning	Real-time auto tuning: 32 steps Advanced gain search	Real-time auto tuning: 40 steps One-touch tuning
8	Control mode	SSCNET III interface (50 Mbps) ▪ Position control mode ▪ Speed control mode	SSCNET III/H interface (150 Mbps) ▪ Position control mode ▪ Speed control mode ▪ Torque control mode
			< J3 compatibility mode > SSCNET III interface (50 Mbps) ▪ Position control mode ▪ Speed control mode
9	The number of DIO points (excluding EM1)	DI: 3 points, DO: 3 points	DI: 3 points, DO: 3 points
10	Encoder pulse output	ABZ-phase (differential line driver)	ABZ-phase (differential line driver)
11	DIO interface	input/output: sink/source	input/output: sink/source
12	Analog input/output	(Output) 10-bit or equivalent × 2ch	(Output) 10-bit or equivalent × 2ch
13	Parameter setting method	Setup software (SETUP221E) MR Configurator2	MR Configurator2
14	Setup software communication function	USB	USB
15	Servo motor (Encoder resolution)	HF-_P series (18-bit ABS) HA-_P series (18-bit ABS)	HG series (22-bit ABS)
16	Motor maximum torque	HF-KP 350%	HG-KR 350%
		HF-MP 300%	HG-MR 300%
17	LED display	7-segment 3-digit	7-segment 3-digit
18	Advanced vibration suppression control	Provided	Provided (advanced vibration suppression control II)
19	Adaptive filter II	Provided	Provided
20	Notch filter	Provided (2 pcs)	Provided (5 pcs)
21	Tough drive	Unprovided	Provided
22	Drive recorder	Unprovided	Provided
23	Forced stop	EM1 (DB stop)	EM1 (DB stop)/EM2 (deceleration to a stop)

Note. For the coasting distance, refer to "1.2.3 Dynamic brake: coasting distance" in "Part 8: Common Reference Material".

Part 3: Review on Replacement of MR-J3- B_ with MR-J4- B_

3.2 Comparison of Networks

POINT
● Refer to "Part 8: Common Reference Material".

3.3 Comparison of Standard Connection Diagrams

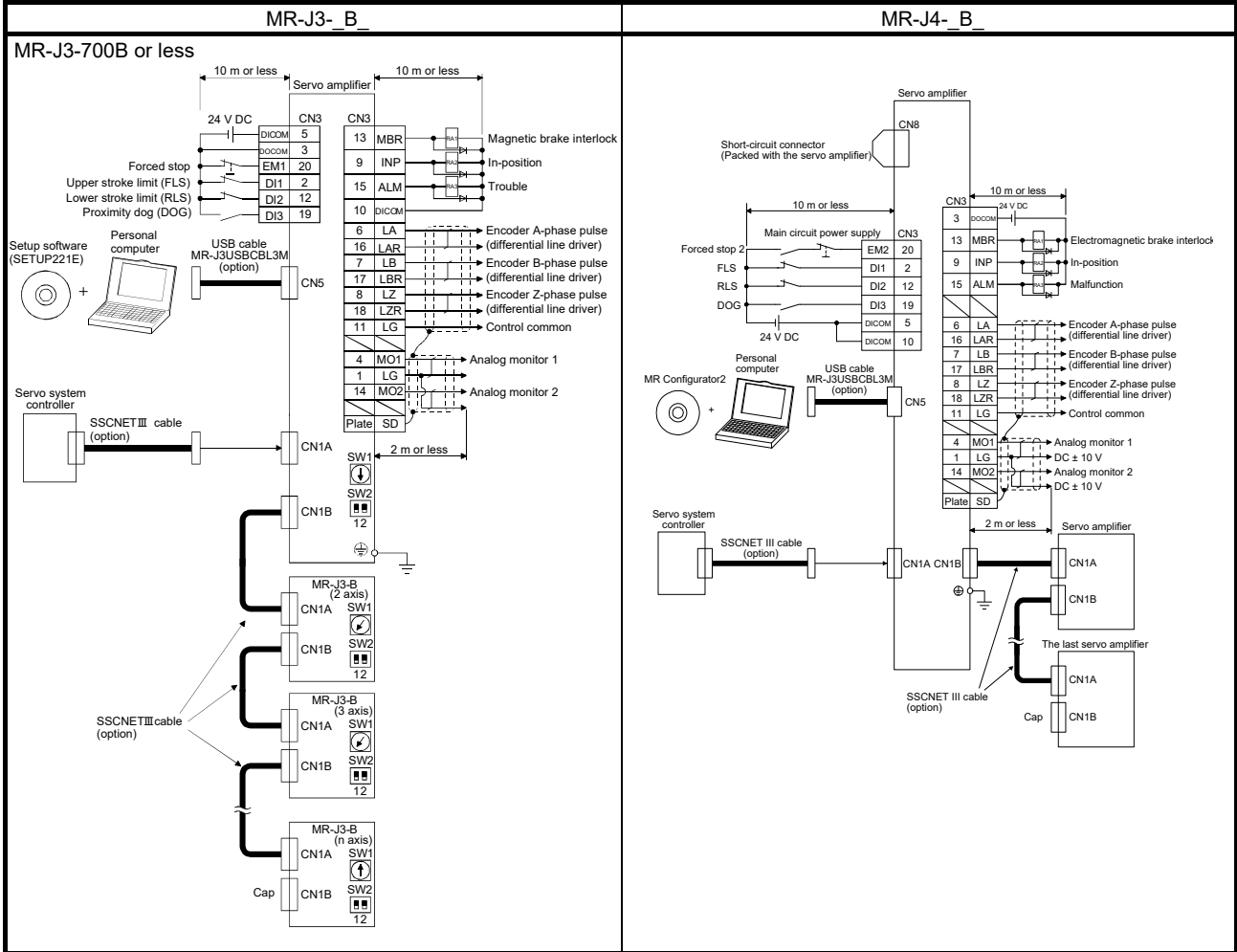

Part 3: Review on Replacement of MR-J3- _B_ with MR-J4- _B_

3.4 List of Corresponding Connectors and Terminal Blocks

An example of connections with the peripheral equipment is shown below. Refer to the respective instruction manuals for details on the signals.

(1) Comparison of connectors (7 kW or less)

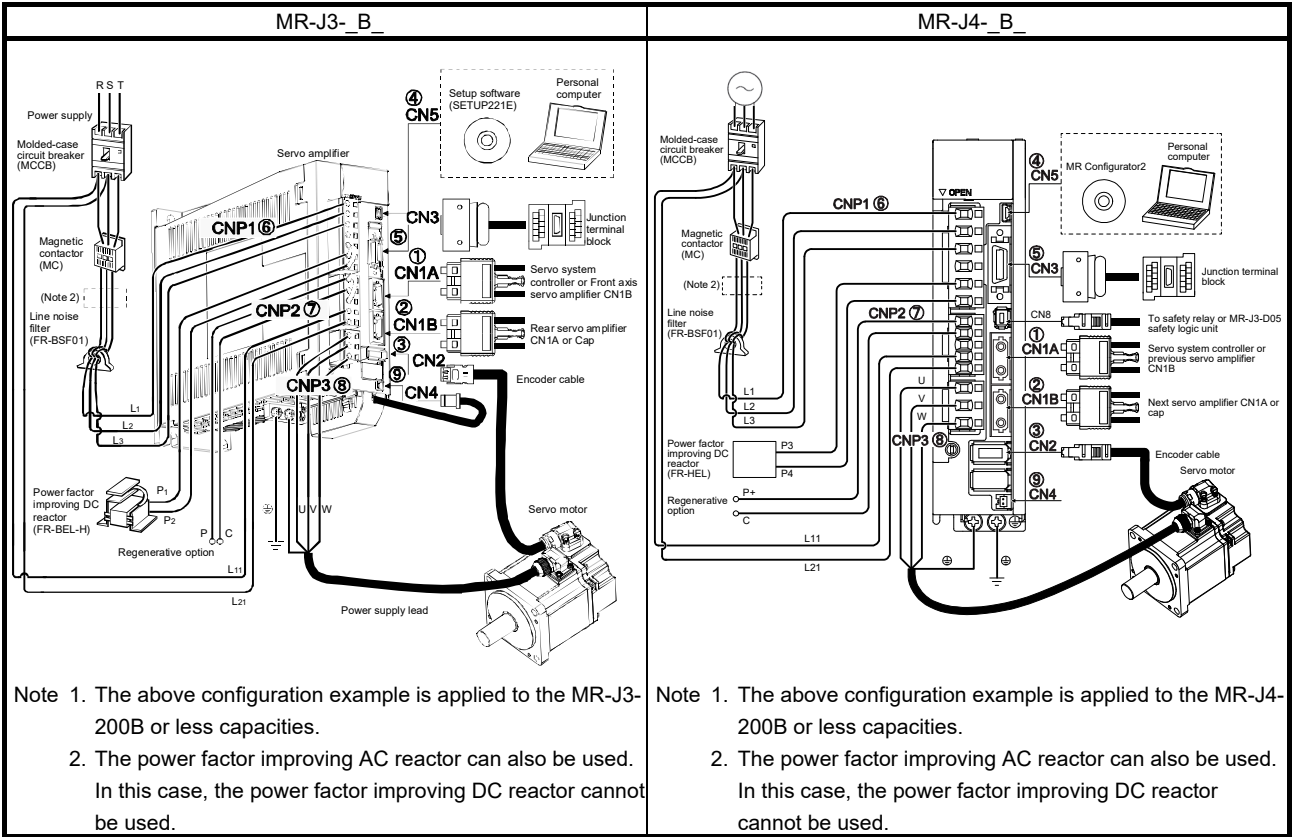

(2) List of connector and terminal block correspondence (7 kW or less)

MR-J3- _B_			MR-J4- _B_			Precautions
No.	Connector name	Connector No.	No.	Connector name	Connector No.	
①	SSCNET III cable connector	CN1A	①	SSCNET III cable connector	CN1A	
②	SSCNET III cable connector	CN1B	②	SSCNET III cable connector	CN1B	
③	Encoder connector	CN2	③	Encoder connector	CN2	
④	USB communication connector	CN5	④	USB communication connector	CN5	
⑤	I/O signal connector	CN3	⑤	I/O signal connector	CN3	
⑥	Main circuit power connector	CNP1	⑥	Main circuit power connector	CNP1	Must switch to the power connector (enclosed with the servo amplifier).
⑦	Control circuit power connector	CNP2	⑦	Control circuit power connector	CNP2	
⑧	Servo motor power connector	CNP3	⑧	Servo motor power output connector	CNP3	
⑨	Battery connector	CN4	⑨	Battery connector	CN4	Prepare a new battery.

Note. When not using the STO function in MR-J4- _B_ , attach a short-circuit connector supplied with a servo amplifier onto CN8 (STO input signal connector).

The configuration of the main circuit terminal block differs depending on capacity. Refer to "Part 8: Common Reference Material".

Part 3: Review on Replacement of MR-J3-_B_ with MR-J4-_B_

(3) Comparison of connectors (11 kW or more)

The above configuration example is for MR-J3-11KB or models with more capacity.

Note 1. The battery (option) is used for the absolute position detection system in the position control mode.
Note 2. The power factor improving AC reactor can also be used. In this case, the power factor improving DC reactor cannot be used. When not using the power factor improving DC reactor, short P1 and P.
Note 3. Refer to the respective instruction manuals for the power supply specification.

The above configuration example is for MR-J4-11KB or models with more capacity.

Note 1. The power factor improving AC reactor can also be used. In this case, the power factor improving DC reactor cannot be used. When not using the power factor improving DC reactor, short P3 and P4.
Note 2. For power supply specifications, refer to "MR-J4-_B_(-RJ) servo amplifier instruction manual".
Note 3. Depending on the main circuit voltage and operation pattern, bus voltage decreases, and that may cause the forced stop deceleration to shift to the dynamic brake deceleration. When dynamic brake deceleration is not required, slow the time to turn off the magnetic contactor.
Note 4. When using the regenerative option, refer to Part 10 section 1.1 or 1.2.

(4) List of connector and terminal block correspondence (11 kW or more)

MR-J3-_B_			MR-J4-_B_			Precautions
No.	Connector name	Connector No.	No.	Connector name	Connector No.	
①	SSCNET III cable connector	CN1A	①	SSCNET III cable connector	CN1A	
②	SSCNET III cable connector	CN1B	②	SSCNET III cable connector	CN1B	
③	Encoder connector	CN2	③	Encoder connector	CN2	The cable needs to be changed when using 15 kW or more HG-JR 1000 r/min series or 22 kW or more HG-JR 1500 r/min series is used.
④	USB communication connector	CN5	④	USB communication connector	CN5	
⑤	I/O signal connector	CN3	⑤	I/O signal connector	CN3	Prepare a new battery.
⑥	Battery connector	CN4	⑥	Battery connector	CN4	

- Note 1.** When not using the STO function in MR-J4-_B_, attach a short-circuit connector supplied with a servo amplifier onto CN8 (STO input signal connector).
Note 2. The configuration of the main circuit terminal block differs depending on capacity. Refer to "Part 8: Common Reference Material".

Part 3: Review on Replacement of MR-J3-_B_ with MR-J4-_B_

(5) Comparison of signals

Signals unique to MR-J4-_B_ are in parentheses.

MR-J3-_B_ < 7 kW or less >		Abbreviation	MR-J4-_B_	
Connector pin assignment	Connector pin No.		Connector pin No.	Connector pin assignment
	CN3-1	LG	CN3-1	
	CN3-2	DI1	CN3-2	
	CN3-3	DOCOM	CN3-3	
	CN3-4	MO1	CN3-4	
	CN3-5	DICOM	CN3-5	
	CN3-6	LA	CN3-6	
	CN3-7	LB	CN3-7	
	CN3-8	LZ	CN3-8	
	CN3-9	INP	CN3-9	
	CN3-10	DICOM	CN3-10	
	CN3-11	LG	CN3-11	
	CN3-12	DI2	CN3-12	
	CN3-13	MBR	CN3-13	
	CN3-14	MO2	CN3-14	
	CN3-15	ALM	CN3-15	
	CN3-16	LAR	CN3-16	
	CN3-17	LBR	CN3-17	
	CN3-18	LZR	CN3-18	
	CN3-19	DI3	CN3-19	
	CN3-20 (Note)	EM1 (EM2)	CN3-20	
Plate	SD	Plate		

Note. The factory setting for MR-J4-_B_ is EM2.

Part 3: Review on Replacement of MR-J3- _B_ with MR-J4- _B_

3.5 Comparison of Peripheral Equipment

POINT
● Refer to "Part 10: Review on Replacement of Optional Peripheral Equipment".

3.6 Comparison of Parameters

 CAUTION	<ul style="list-style-type: none">● Never perform extreme adjustments and changes to the parameters, otherwise the operation may become unstable.● If fixed values are written in the digits of a parameter, do not change these values.● Do not change parameters for manufacturer setting.● Do not enter any setting value other than those specified for each parameter.
--	--

POINT
<ul style="list-style-type: none">● For the parameter converter function, refer to "Part 8: Common Reference Material".● The parameter whose symbol is preceded by * is enabled with the following conditions:<ul style="list-style-type: none">*: After setting the parameter, cycle the power or reset the controller.** : After setting the parameter, cycle the power.● For details about parameter settings for replacement, refer to the "MR-J4- _B_ (-RJ) Servo Amplifier Instruction Manual" to set parameters.

POINT
<ul style="list-style-type: none">● With MR-J4- _B_ , the deceleration to a stop function is enabled in the factory setting. To disable the deceleration to a stop function, set [Pr.PA04] to "0 _ _ _".● In cases of 11 kW or more, the dynamic brake (DB) needs to be assigned to a device in [Pr.PD07] to [Pr. PD09].

Part 3: Review on Replacement of MR-J3-_B_ with MR-J4-_B_

3.6.1 Setting requisite parameters upon replacement

The parameters shown in this section are a minimum number of parameters that need to be set for simultaneous replacement. Depending on the settings of the currently used servo amplifier, parameters other than these may need to be set.

Parameter number	Name	Precautions
PA01	Control type selection	In MR-J3-_B_, the maximum torque was set to 300% as the initial value. However, in MR-J4-_B_, the maximum torque is set to 350% as the initial value when using the HG-KR servo motor. Refer to Part 9 "Review on Replacement of Motor", check the operation status on customer side, and revise the settings as required.
PA02	Regenerative option selection	The setting value must be changed according to the option model.
PA04	Function selection A-1 Servo forced stop selection	Forced stop deceleration function selection To configure the same settings as for MR-J3-_B_, select "Forced stop deceleration function disabled (with EM1 used)".
PA08	Gain adjustment mode selection	The setting value needs to be changed according to the auto tuning mode.
PA09	Auto tuning response	Auto tuning response setting Refer to "3.6.3 Comparison of parameter details" for the setting value of this parameter upon replacement. It is necessary to make gain adjustment again when replacing. For details on how to make gain adjustments, refer to Chapter 6 of the "MR-J4-_B_(-RJ) Servo Amplifier Instruction Manual". The setting value needs be changed based on the standard machine resonance frequency.
PA10	In-position range	The setting needs to be changed depending on the servo motor.
PA15	Encoder output pulse	Used to set the encoder pulses (A-phase and B-phase) output by the servo amplifier.
PA19	Parameter writing inhibit	Change the setting value as necessary.
PB06	Load to motor inertia ratio	The unit system is different. (0.1-fold → 0.01-fold) Pay attention to setting value.
PB07	Model loop gain	The unit system is different. (rad/s → 0.1 rad/s)
PB08	Position loop gain	The unit system is different. (rad/s → 0.1 rad/s)
PB13	Machine resonance suppression filter 1	Change the setting value according to the frequency and depth.
PB14	Notch shape selection 1	
PB15	Machine resonance suppression filter 2	Change the setting value according to the frequency and depth.
PB16	Notch shape selection 2	
PB29	Load to motor inertia ratio after gain switching	The unit system is different. (0.1-fold → 0.01-fold) Pay attention to setting value.
PB30	Position loop gain after gain switching	It is necessary to convert the ratio to a value to change the setting value.
PB31	Speed loop gain after gain switching	It is necessary to convert the ratio to a value to change the setting value.
PB32	Speed integral compensation after gain switching	It is necessary to convert the ratio to a value to change the setting value.
PC09	Analog monitor 1 output	The setting value must be changed according to monitor output data.
PC10	Analog monitor 2 output	The "maximum speed" and "maximum torque" differ depending on the servo motor currently in use. Set them in accordance with the servo motor.
PC11	Analog monitor 1 offset	Depends on hardware. It is necessary to change the setting value.
PC12	Analog monitor 2 offset	Depends on hardware. It is necessary to change the setting value.

Part 3: Review on Replacement of MR-J3-_B_ with MR-J4-_B_

3.6.2 Parameter comparison list

MR-J3-_B_ parameters					MR-J4-_B_ parameters				
No.	Abbreviation	Parameter name	Initial value	Customer setting value	No.	Abbreviation	Parameter name	Initial value	Customer setting value
PA01	**STY	For manufacturer setting	0000h		PA01	**STY	Operation mode	1000h	
PA02	**REG	Regenerative option	0000h		PA02	**REG	Regenerative option	0000h	
PA03	*ABS	Absolute position detection system	0000h		PA03	*ABS	Absolute position detection system	0000h	
PA04	*AOP1	Function selection A-1	0000h		PA04	*AOP1	Function selection A-1	2000h	
PA05		For manufacturer setting	0		PA05		For manufacturer setting	10000	
PA06			1		PA06			1	
PA07			1		PA07			1	
PA08	ATU	Auto tuning mode	0001h		PA08	ATU	Auto tuning mode	0001h	
PA09	RSP	Auto tuning response	12		PA09	RSP	Auto tuning response	16	
PA10	INP	In-position range	100		PA10	INP	In-position range	1600	
PA11		For manufacturer setting	1000.0		PA11		For manufacturer setting	1000.0	
PA12			1000.0		PA12			1000.0	
PA13			0000h		PA13			0000h	
PA14	*POL	Rotation direction selection	0		PA14	*POL	Rotation direction selection	0	
PA15	*ENR	Encoder output pulses	4000		PA15	*ENR	Encoder output pulses	4000	
PA16		For manufacturer setting	0		PA16	*ENR2	Encoder output pulses 2	1	
PA17			0000h		PA17	**MSR	Servo motor series setting	0000h	
PA18			0000h		PA18	**MTY	Servo motor type setting	0000h	
PA19	*BLK	Parameter write inhibit	000Bh		PA19	*BLK	Parameter writing inhibit	00ABh	
PB01	FILT	Adaptive tuning mode (adaptive filter II)	0000h		PB01	FILT	Adaptive tuning mode (adaptive filter II)	0000h	
PB02	VRFT	Vibration suppression control tuning mode (advanced vibration suppression control)	0000h		PB02	VRFT	Vibration suppression control tuning mode (advanced vibration suppression control II)	0000h	
PB03		For manufacturer setting	0		PB03	TFBGN	Torque feedback loop gain	18000	
PB04	FFC	Feed forward gain	0		PB04	FFC	Feed forward gain	0	
PB05		For manufacturer setting	500		PB05		For manufacturer setting	500	
PB06	GD2	Ratio of load inertia moment to servo motor inertia moment	7.0		PB06	GD2	Load to motor inertia ratio	7.00	
PB07	PG1	Model loop gain	24		PB07	PG1	Model loop gain	15.0	
PB08	PG2	Position loop gain	37		PB08	PG2	Position loop gain	37.0	
PB09	VG2	Speed loop gain	823		PB09	VG2	Speed loop gain	823	
PB10	VIC	Speed integral compensation	33.7		PB10	VIC	Speed integral compensation	33.7	
PB11	VDC	Speed differential compensation	980		PB11	VDC	Speed differential compensation	980	
PB12	OVA	Overshoot amount compensation	0		PB12	OVA	Overshoot amount compensation	0	
PB13	NH1	Machine resonance suppression filter 1	4500		PB13	NH1	Machine resonance suppression filter 1	4500	
PB14	NHQ1	Notch shape selection 1	0000h		PB14	NHQ1	Notch shape selection 1	0000h	
PB15	NH2	Machine resonance suppression filter 2	4500		PB15	NH2	Machine resonance suppression filter 2	4500	
PB16	NHQ2	Notch shape selection 2	0000h		PB16	NHQ2	Notch shape selection 2	0000h	
PB17		Automatic setting parameter			PB17	NHF	Shaft resonance suppression filter	0000h	
PB18	LPF	Low-pass filter setting	3141		PB18	LPF	Low-pass filter setting	3141	
PB19	VRF1	Vibration suppression control vibration frequency setting	100.0		PB19	VRF11	Vibration suppression control 1 - Vibration frequency	100.0	
PB20	VRF2	Vibration suppression control resonance frequency setting	100.0		PB20	VRF12	Vibration suppression control 1 - Resonance frequency	100.0	
PB21		For manufacturer setting	0.00		PB21	VRF13	Vibration suppression control 1 - Vibration frequency damping	0.00	
PB22			0.00		PB22	VRF14	Vibration suppression control 1 - Resonance frequency damping	0.00	
PB23	VFBF	Low-pass filter selection	0000h		PB23	VFBF	Low-pass filter selection	0000h	

Part 3: Review on Replacement of MR-J3-_B_ with MR-J4-_B_

MR-J3-_B_ parameters					MR-J4-_B_ parameters				
No.	Abbreviation	Parameter name	Initial value	Customer setting value	No.	Abbreviation	Parameter name	Initial value	Customer setting value
PB24	*MVS	Slight vibration suppression control selection	0000h		PB24	*MVS	Slight vibration suppression control	0000h	
PB25		For manufacturer setting	0000h		PB25	*BOP1	Function selection B-1	0000h	
PB26	*CDP	Gain changing selection	0000h		PB26	*CDP	Gain switching function	0000h	
PB27	CDL	Gain changing condition	10		PB27	CDL	Gain switching condition	10	
PB28	CDT	Gain changing time constant	1		PB28	CDT	Gain switching time constant	1	
PB29	GD2B	Gain changing ratio of load inertia moment to servo motor inertia moment	7.0		PB29	GD2B	Load to motor inertia ratio after gain switching	7.00	
PB30	PG2B	Gain changing position loop gain	37		PB30	PG2B	Position loop gain after gain switching	0.0	
PB31	VG2B	Gain changing speed loop gain	823		PB31	VG2B	Speed loop gain after gain switching	0	
PB32	VICB	Gain changing speed integral compensation	33.7		PB32	VICB	Speed integral compensation after gain switching	0.0	
PB33	VRF1B	Gain changing vibration suppression control vibration frequency setting	100.0		PB33	VRF11B	Vibration suppression control 1 - Vibration frequency after gain switching	0.0	
PB34	VRF2B	Gain changing vibration suppression control resonance frequency setting	100.0		PB34	VRF12B	Vibration suppression control 1 - Resonance frequency after gain switching	0.0	
PB35		For manufacturer setting	0.00		PB35	VRF13B	Vibration suppression control 1 - Vibration frequency damping after gain switching	0.00	
PB36			0.00		PB36	VRF14B	Vibration suppression control 1 - Resonance frequency damping after gain switching	0.00	
PB37			100		PB37		For manufacturer setting	1600	
PB38			0.0		PB38			0.00	
PB39			0.0		PB39			0.00	
PB40			0.0		PB40			0.00	
PB41			1125		PB41			0	
PB42			1125		PB42			0	
PB43			0004h		PB43			0000h	
PB44			0.0		PB44			0.00	
PB45	CNHF	Vibration suppression control filter 2	0000h		PB45	CNHF	Command notch filter	0000h	
PC01	ERZ	Error excessive alarm level	3		PC01	ERZ	Error excessive alarm level	0	
PC02	MBR	Electromagnetic brake sequence output	0		PC02	MBR	Electromagnetic brake sequence output	0	
PC03	*ENRS	Encoder output pulses selection	0000h		PC03	*ENRS	Encoder output pulse selection	0000h	
PC04	**COP1	Function selection C-1	0000h		PC04	**COP1	Function selection C-1	0000h	
PC05	**COP2	Function selection C-2	0000h		PC05	**COP2	Function selection C-2	0000h	
PC06	*COP3	Function selection C-3	0000h		PC06	*COP3	Function selection C-3	0000h	
PC07	ZSP	Zero speed	50		PC07	ZSP	Zero speed	50	
PC08		For manufacturer setting	0		PC08	OSL	Overspeed alarm detection level	0	
PC09	MOD1	Analog monitor 1 output	0000h		PC09	MOD1	Analog monitor 1 output	0000h	
PC10	MOD2	Analog monitor 2 output	0001h		PC10	MOD2	Analog monitor 2 output	0001h	
PC11	MO1	Analog monitor 1 offset	0		PC11	MO1	Analog monitor 1 offset	0	
PC12	MO2	Analog monitor 2 offset	0		PC12	MO2	Analog monitor 2 offset	0	
PC13	MOSDL	Analog monitor feedback position output standard data Low	0		PC13	MOSDL	Analog monitor - Feedback position output standard data - Low	0	
PC14	MOSDH	Analog monitor feedback position output standard data High	0		PC14	MOSDH	Analog monitor - Feedback position output standard data - High	0	
PC15		For manufacturer setting	0		PC15		For manufacturer setting	0	
PC16			0000h		PC16			0000h	
PC17	**COP4	Function selection C-4	0000h		PC17	**COP4	Function selection C-4	0000h	
PC18		For manufacturer setting	0000h		PC18	*COP5	Function selection C-5	0000h	
PC19			0000h		PC19		For manufacturer setting	0000h	
PC20	*COP7	Function selection C-7	0000h		PC20	*COP7	Overspeed alarm detection level	0000h	

Part 3: Review on Replacement of MR-J3-_B_ with MR-J4-_B_

MR-J3-_B_ parameters					MR-J4-_B_ parameters								
No.	Abbreviation	Parameter name	Initial value	Customer setting value	No.	Abbreviation	Parameter name	Initial value	Customer setting value				
PC21	*BPS	Alarm history clear	0000h		PC21	*BPS	Alarm history clear	0000h					
PC22		For manufacturer setting	0000h		PC22		For manufacturer setting	0					
PC23			0000h		PC23			0000h					
PC24			0000h		PC24			RSBR	Forced stop deceleration time constant	100			
PC25			0000h		PC25		For manufacturer setting	0					
PC26			0000h		PC26					**COP8	Function selection C-8	0000h	
PC27			0000h		PC27	**COP9	Function selection C-9	0000h					
PC28			0000h		PC28		For manufacturer setting	0000h					
PC29			0000h		PC29					*COPB	Function selection C-B	0000h	
PC30			0000h		PC30		For manufacturer setting	0					
PC31			0000h		PC31					RSUP1	Vertical axis freefall prevention compensation amount	0	
PC32			0000h		PC32		For manufacturer setting	0000h					
PD01			0000h		PD01						For manufacturer setting	0000h	
PD02			0000h		PD02	*DIA2	Input signal automatic on selection 2	0000h					
PD03			0000h		PD03		For manufacturer setting	0020h					
PD04	0000h		PD04	0021h									
PD05	0000h		PD05	0022h									
PD06	0000h		PD06	0000h									
PD07	*DO1	Output signal device selection 1 (CN3-13)	0005h		PD07	*DO1	Output device selection 1	0005h					
PD08	*DO2	Output signal device selection 2 (CN3-9)	0004h		PD08	*DO2	Output device selection 2	0004h					
PD09	*DO3	Output signal device selection 3 (CN3-15)	0003h		PD09	*DO3	Output device selection 3	0003h					
PD10		For manufacturer setting	0000h		PD10		For manufacturer setting	0000h					
PD11			0004h		PD11					*DIF	Input filter setting (Note)	0004h	
PD12			0000h		PD12					*DOP1	Function selection D-1	0000h	
PD13			0000h		PD13					*DOP2	Function selection D-2	0000h	
PD14	*DOP3	Function selection D-3	0000h		PD14	*DOP3	Function selection D-3	0000h					
PD15	*IDCS	For manufacturer setting	0000h		PD15	*IDCS	Driver communication setting	0000h					
PD16	*MD1	Driver communication setting - Master - Transmit data selection 1	0000h		PD16	*MD1	Driver communication setting - Master - Transmit data selection 1	0000h					
PD17	*MD2	Driver communication setting - Master - Transmit data selection 2	0000h		PD17	*MD2	Driver communication setting - Master - Transmit data selection 2	0000h					
PD18		For manufacturer setting	0000h		PD18		For manufacturer setting	0000h					
PD19			0000h		PD19					0000h			
PD20	*SLA1	Driver communication setting - Slave - Master axis No. selection 1	0		PD20	*SLA1	Driver communication setting - Slave - Master axis No. selection 1	0					
PD21		For manufacturer setting	0		PD21		For manufacturer setting	0					
PD22			0		PD22			0					
PD23			0		PD23			0					
PD24			0000h		PD24			0000h					
PD25			0000h		PD25			0000h					
PD26			0000h		PD26			0000h					
PD27			0000h		PD27			0000h					
PD28			0000h		PD28			0000h					
PD29			0000h		PD29			0000h					
PD30			TLC	Master-slave operation - Torque command coefficient on slave	0000h				PD30	TLC	Master-slave operation - Torque command coefficient on slave	0	
PD31	VLC	Master-slave operation - Speed limit coefficient on slave	0000h		PD31	VLC	Master-slave operation - Speed limit coefficient on slave	0					
PD32	VLL	Master-slave operation - Speed limit adjusted value on slave	0000h		PD32	VLL	Master-slave operation - Speed limit adjusted value on slave	0					

Note Refer to the servo system controller instruction manual for the setting.

Part 3: Review on Replacement of MR-J3-_B_ with MR-J4-_B_

3.6.3 Comparison of parameter details

MR-J3-_B_			MR-J4-_B_		
No.	Name and function	Initial value	No.	Name and function	Initial value
PA01	<p>Control mode</p> <p>Turn off the power and then on again after setting the parameter to validate the parameter value.</p> <p>This parameter is supported by a combination of a servo amplifier, whose software version is C4 or later (manufactured in January 2010 or later), and a HF-KP servo motor (manufactured in August 2009 or later). Check the software version using status display or Setup software (SETUP221E).</p> <p>When the 350% maximum torque setting of the HF-KP servo motor is enabled, set the torque limit value in the controller at 1000%.</p> <p>A HF-KP servo motor with a decelerator and servo motors except the HF-KP series do not support the 350 maximum torque setting. Making the 350 maximum torque setting valid when using these servo motors causes the [AL. 37 parameter error].</p> <p>Set the control loop composition of the servo amplifier, and the maximum torque of the HF-KP series servo motor.</p> <p>By making the high-response control valid in the control loop composition, response of the servo can be increased compared to the response under the standard control (factory setting). Moreover, the track ability for a command and the settling time in machines with high rigidity can be decreased. To further shorten the settling time using the auto tuning results of the high-response control, increase the setting of model loop gain ([Pr. PB07]) in the manual mode.</p> <p>By making the 350 maximum torque setting valid, the maximum torque of the HF-KP servo motor can be increased from 300 to 350. To operate at the maximum torque of 350, operate within the range of overload protection characteristic. If operated beyond the overload protection characteristic range, servo motor overheat (46), overload 1 (50), and overload 2 (51) may occur.</p> <p>0 x 0 0: Control type selection 0: Standard control (350 maximum torque setting of HF-KP servo motor Invalid) 3: Standard control (350 maximum torque setting of HF-KP servo motor Valid) 4: High-response control valid (350 maximum torque setting of HF-KP servo motor Invalid) 5: High-response control valid (350 maximum torque setting of HF-KP servo motor Valid)</p>	0000h	PA01	<p>Operation mode</p> <p>Select an operation mode.</p> <p>___ x:</p> <p>For manufacturer setting</p>	0h
			<p>__ x _:</p> <p>Operation mode selection</p> <p>0: Standard control mode</p> <p>Setting other than above will result in [AL. 37 Parameter error].</p>	0h	
			<p>_ x _ _:</p> <p>For manufacturer setting</p>	0h	
			<p>x _ _ _:</p> <p>Operation mode selection</p> <p>To change this digit, use an application software "MR Mode Change". When you change it without the application, [AL. 3E Operation mode error] will occur.</p> <p>0: J3 compatibility mode 1: J4 mode</p>	1h	

Part 3: Review on Replacement of MR-J3-__B__ with MR-J4-__B__

MR-J3-__B__			MR-J4-__B__		
No.	Name and function	Initial value	No.	Name and function	Initial value
PA02	<p>Regenerative option</p> <p>This parameter value and switch power off once, then switch it on again to make that parameter setting valid. Wrong setting may cause the regenerative option to burn.</p> <p>If the regenerative option selected is not for use with the servo amplifier, [AL.37 parameter error] occurs.</p> <p>0 0 x x: Selection of regenerative option</p> <p>00: Regenerative option is not used</p> <ul style="list-style-type: none"> ▪ For servo amplifier of 100 W, regenerative resistor is not used. ▪ For servo amplifier of 0.2 kW to 7 kW, built-in regenerative resistor is used. ▪ Supplied regenerative resistors or regenerative option is used with the servo amplifier of 11 kW to 22 kW. <p>01: FR-BU2-(H)/FR-RC-(H)/FR-CV-(H) 02: MR-RB032 03: MR-RB12 04: MR-RB32 05: MR-RB30 06: MR-RB50 (Cooling fan is required) 08: MR-RB31 09: MR-RB51 (Cooling fan is required) 80: MR-RB1H-4 81: MR-RB3M-4 (Cooling fan is required) 82: MR-RB3G-4 (Cooling fan is required) 83: MR-RB5G-4 (Cooling fan is required) 84: MR-RB34-4 (Cooling fan is required) 85: MR-RB54-4 (Cooling fan is required) FA: When the supplied regenerative resistor is cooled by the cooling fan to increase the ability with the servo amplifier of 11kW to 22kW.</p> <p>Note. The setting is for the servo amplifier of 22 kW or less.</p>	0000h	PA02	<p>Same as MR-J3</p> <p>Regenerative option</p> <p>Used to select the regenerative option.</p> <p>Incorrect setting may cause the regenerative option to burn.</p> <p>If a selected regenerative option is not for use with the servo amplifier, [AL. 37 Parameter error] occurs.</p> <p>__ x x: Regenerative option selection</p> <p>00: Regenerative option is not used.</p> <ul style="list-style-type: none"> ▪ For servo amplifier of 100 W, regenerative resistor is not used. ▪ For servo amplifier of 0.2 kW to 7 kW, built-in regenerative resistor is used. ▪ Supplied regenerative resistors or regenerative option is used with the servo amplifier of 11 kW to 22 kW. <p>01: FR-RC-(H)/FR-CV-(H)/FR-BU2-(H) When you use FR-RC-(H) or FR-CV-(H), "Mode 2 (__ __ 1)" of "Undervoltage alarm detection mode selection" in [Pr. PC20]. 02: MR-RB032 03: MR-RB12 04: MR-RB32 05: MR-RB30 06: MR-RB50 (Cooling fan is required.) 08: MR-RB31 09: MR-RB51 (Cooling fan is required.) 0B: MR-RB3N 0C: MR-RB5N (Cooling fan is required.) 80: MR-RB1H-4 81: MR-RB3M-4 (Cooling fan is required.) 82: MR-RB3G-4 (Cooling fan is required.) 83: MR-RB5G-4 (Cooling fan is required.) 84: MR-RB34-4 (Cooling fan is required.) 85: MR-RB54-4 (Cooling fan is required.) 91: MR-RB3U-4 (Cooling fan is required.) 92: MR-RB5U-4 (Cooling fan is required.) FA: When the supplied regenerative resistors or the regenerative option is cooled by the cooling fan to increase the ability with the servo amplifier of 11 kW to 22 kW.</p> <p>_ x __ : For manufacturer setting</p> <p>x __ __ : For manufacturer setting</p>	00h
					0h
					0h

Part 3: Review on Replacement of MR-J3- _B_ with MR-J4- _B_

MR-J3- _B_			MR-J4- _B_																							
No.	Name and function	Initial value	No.	Name and function	Initial value																					
PA03	<p>Absolute position detection system</p> <p>This parameter is made valid when power is switched off, then on after setting, or when the controller reset has been performed.</p> <p>This parameter cannot be used in the speed control mode.</p> <p>Set this parameter when using the absolute position detection system in the position control mode.</p> <p>0 0 0 x:</p> <p>Selection of absolute position detection system</p> <p>0: Used in incremental system</p> <p>1: Used in absolute position detection system</p>	0000h	PA03	<p>Same as MR-J3</p> <p>Absolute position detection system</p> <p>Set this parameter when using the absolute position detection system.</p> <p>The parameter is not available in the speed control mode and torque control mode.</p> <p>___ x:</p> <p>Absolute position detection system selection</p> <p>0: Disabled (used in incremental system)</p> <p>1: Enabled (used in absolute position detection system)</p> <p>_ _ x _:</p> <p>For manufacturer setting</p> <p>_ x _ _:</p> <p>For manufacturer setting</p> <p>x _ _ _:</p> <p>For manufacturer setting</p>	0h																					
PA04	<p>Function selection A-1</p> <p>This parameter is made valid when power is switched off, then on after setting, or when the controller reset has been performed.</p> <p>The servo forced stop function is avoidable.</p> <p>0 x 0 0:</p> <p>Selection of servo forced stop</p> <p>0: Valid (Forced stop (EM1) is used)</p> <p>1: Invalid (Forced stop (EM1) is not used.)</p> <p>When not using the forced stop (EM1) of servo amplifier, set the selection of servo forced stop to Invalid (_ _ 1 _). At this time, the forced stop (EM1) automatically turns on inside the servo amplifier.</p>	0000h	PA04	<p>Same setting as MR-J3</p> <p>Function selection A-1</p> <p>This is used to select the forced stop input and forced stop deceleration function.</p> <p>___ x:</p> <p>For manufacturer setting</p> <p>_ _ x _:</p> <p>For manufacturer setting</p> <p>_ x _ _:</p> <p>Servo forced stop selection</p> <p>0: Enabled (The forced stop input EM2 or EM1 is used.)</p> <p>1: Disabled (The forced stop input EM2 and EM1 are not used.)</p> <p>Refer to table 3.1 for details.</p> <p>x _ _ _:</p> <p>Forced stop deceleration function selection</p> <p>0: Forced stop deceleration function disabled (EM1)</p> <p>2: Forced stop deceleration function enabled (EM2)</p> <p>Refer to table 3.1 for details.</p> <p>Table 3.1 Deceleration method</p> <table border="1"> <thead> <tr> <th rowspan="2">Setting value</th> <th rowspan="2">EM2/EM1</th> <th colspan="2">Deceleration method</th> </tr> <tr> <th>EM2 or EM1 is off</th> <th>Controller forced stop is enabled/Alarm occurred</th> </tr> </thead> <tbody> <tr> <td>0 0 _ _</td> <td>EM1</td> <td>MBR (Electromagnetic brake interlock) turns off without the forced stop deceleration.</td> <td>MBR (Electromagnetic brake interlock) turns off without the forced stop deceleration.</td> </tr> <tr> <td>2 0 _ _</td> <td>EM2</td> <td>MBR (Electromagnetic brake interlock) turns off after the forced stop deceleration.</td> <td>MBR (Electromagnetic brake interlock) turns off after the forced stop deceleration.</td> </tr> <tr> <td>0 1 _ _</td> <td>Not using EM2 and EM1</td> <td rowspan="2" style="text-align: center;">/</td> <td>MBR (Electromagnetic brake interlock) turns off without the forced stop deceleration.</td> </tr> <tr> <td>2 1 _ _</td> <td>Not using EM2 and EM1</td> <td>MBR (Electromagnetic brake interlock) turns off after the forced stop deceleration.</td> </tr> </tbody> </table>	Setting value	EM2/EM1	Deceleration method		EM2 or EM1 is off	Controller forced stop is enabled/Alarm occurred	0 0 _ _	EM1	MBR (Electromagnetic brake interlock) turns off without the forced stop deceleration.	MBR (Electromagnetic brake interlock) turns off without the forced stop deceleration.	2 0 _ _	EM2	MBR (Electromagnetic brake interlock) turns off after the forced stop deceleration.	MBR (Electromagnetic brake interlock) turns off after the forced stop deceleration.	0 1 _ _	Not using EM2 and EM1	/	MBR (Electromagnetic brake interlock) turns off without the forced stop deceleration.	2 1 _ _	Not using EM2 and EM1	MBR (Electromagnetic brake interlock) turns off after the forced stop deceleration.	0h
Setting value	EM2/EM1	Deceleration method																								
		EM2 or EM1 is off	Controller forced stop is enabled/Alarm occurred																							
0 0 _ _	EM1	MBR (Electromagnetic brake interlock) turns off without the forced stop deceleration.	MBR (Electromagnetic brake interlock) turns off without the forced stop deceleration.																							
2 0 _ _	EM2	MBR (Electromagnetic brake interlock) turns off after the forced stop deceleration.	MBR (Electromagnetic brake interlock) turns off after the forced stop deceleration.																							
0 1 _ _	Not using EM2 and EM1	/	MBR (Electromagnetic brake interlock) turns off without the forced stop deceleration.																							
2 1 _ _	Not using EM2 and EM1		MBR (Electromagnetic brake interlock) turns off after the forced stop deceleration.																							

Part 3: Review on Replacement of MR-J3- _B_ with MR-J4- _B_

MR-J3- _B_			MR-J4- _B_																																																																																																																																																																										
No.	Name and function	Initial value	No.	Name and function	Initial value																																																																																																																																																																								
PA08	<p>Auto tuning mode</p> <p>This parameter cannot be used in the torque control mode.</p> <p>Make gain adjustment using auto tuning.</p> <p>Auto tuning mode [Pr. PA08]</p> <p>Select the gain adjustment mode.</p> <p>0 0 0 x:</p> <p>Gain adjustment mode setting</p> <p>0: Interpolation mode (Automatically set parameter No. (Note) [Pr. PB06/PB08/PB09/PB10])</p> <p>1: Auto tuning mode 1 (Automatically set parameter No. (Note) [Pr. PB06/PB07/PB08/PB09/PB10])</p> <p>2: Auto tuning mode 2 (Automatically set parameter No. [Pr. PB07/PB08/PB09/PB10])</p> <p>3: Manual mode</p> <table border="1"> <thead> <tr> <th>Parameter No.</th> <th>Name</th> </tr> </thead> <tbody> <tr> <td>PB06</td> <td>Ratio of load inertia moment to servo motor inertia moment</td> </tr> <tr> <td>PB07</td> <td>Model loop gain</td> </tr> <tr> <td>PB08</td> <td>Position loop gain</td> </tr> <tr> <td>PB09</td> <td>Speed loop gain</td> </tr> <tr> <td>PB10</td> <td>Speed integral compensation</td> </tr> </tbody> </table> <p>Note. The parameters have the following names.</p>	Parameter No.	Name	PB06	Ratio of load inertia moment to servo motor inertia moment	PB07	Model loop gain	PB08	Position loop gain	PB09	Speed loop gain	PB10	Speed integral compensation	0001h	PA08	<p>Same setting as MR-J3</p> <p>Auto tuning response</p> <p>Set a response of the auto tuning.</p> <p>___x:</p> <p>Gain adjustment mode selection</p> <p>0: 2 gain adjustment mode 1 (interpolation mode)</p> <p>1: Auto tuning mode 1</p> <p>2: Auto tuning mode 2</p> <p>3: Manual mode</p> <p>4: 2 gain adjustment mode 2</p> <p>__x_:</p> <p>For manufacturer setting</p> <p>_x_:</p> <p>For manufacturer setting</p> <p>x_:</p> <p>For manufacturer setting</p>	1h																																																																																																																																																												
Parameter No.	Name																																																																																																																																																																												
PB06	Ratio of load inertia moment to servo motor inertia moment																																																																																																																																																																												
PB07	Model loop gain																																																																																																																																																																												
PB08	Position loop gain																																																																																																																																																																												
PB09	Speed loop gain																																																																																																																																																																												
PB10	Speed integral compensation																																																																																																																																																																												
PA09	<p>Auto tuning response</p> <p>If the machine hunts or generates large gear sound, decrease the set value. To improve performance, e.g. shorten the settling time, increase the set value.</p> <table border="1"> <thead> <tr> <th>Setting value</th> <th>Response</th> <th>Guideline for machine resonance frequency [Hz]</th> <th>Setting value</th> <th>Response</th> <th>Guideline for machine resonance frequency [Hz]</th> </tr> </thead> <tbody> <tr><td>1</td><td rowspan="16">Low response</td><td>10.0</td><td>17</td><td rowspan="16">Middle response</td><td>67.1</td></tr> <tr><td>2</td><td>11.3</td><td>18</td><td>75.6</td></tr> <tr><td>3</td><td>12.7</td><td>19</td><td>85.2</td></tr> <tr><td>4</td><td>14.3</td><td>20</td><td>95.9</td></tr> <tr><td>5</td><td>16.1</td><td>21</td><td>108.0</td></tr> <tr><td>6</td><td>18.1</td><td>22</td><td>121.7</td></tr> <tr><td>7</td><td>20.4</td><td>23</td><td>137.1</td></tr> <tr><td>8</td><td>23.0</td><td>24</td><td>154.4</td></tr> <tr><td>9</td><td>25.9</td><td>25</td><td>173.9</td></tr> <tr><td>10</td><td>29.2</td><td>26</td><td>195.9</td></tr> <tr><td>11</td><td>32.9</td><td>27</td><td>220.6</td></tr> <tr><td>12</td><td>37.0</td><td>28</td><td>248.5</td></tr> <tr><td>13</td><td>41.7</td><td>29</td><td>279.9</td></tr> <tr><td>14</td><td>47.0</td><td>30</td><td>315.3</td></tr> <tr><td>15</td><td>52.9</td><td>31</td><td>355.1</td></tr> <tr><td>16</td><td>Middle response</td><td>59.6</td><td>32</td><td>High response</td><td>400.0</td></tr> </tbody> </table>	Setting value	Response	Guideline for machine resonance frequency [Hz]	Setting value	Response	Guideline for machine resonance frequency [Hz]	1	Low response	10.0	17	Middle response	67.1	2	11.3	18	75.6	3	12.7	19	85.2	4	14.3	20	95.9	5	16.1	21	108.0	6	18.1	22	121.7	7	20.4	23	137.1	8	23.0	24	154.4	9	25.9	25	173.9	10	29.2	26	195.9	11	32.9	27	220.6	12	37.0	28	248.5	13	41.7	29	279.9	14	47.0	30	315.3	15	52.9	31	355.1	16	Middle response	59.6	32	High response	400.0	12	PA09	<p>Auto tuning response</p> <p>Set a response of the auto tuning.</p> <table border="1"> <thead> <tr> <th rowspan="2">Setting value</th> <th colspan="2">Machine characteristic</th> <th rowspan="2">Setting value</th> <th colspan="2">Machine characteristic</th> </tr> <tr> <th>Response</th> <th>Guideline for machine resonance frequency [Hz]</th> <th>Response</th> <th>Guideline for machine resonance frequency [Hz]</th> </tr> </thead> <tbody> <tr><td>1</td><td rowspan="20">Low response</td><td>2.7</td><td>21</td><td rowspan="20">Middle response</td><td>67.1</td></tr> <tr><td>2</td><td>3.6</td><td>22</td><td>75.6</td></tr> <tr><td>3</td><td>4.9</td><td>23</td><td>85.2</td></tr> <tr><td>4</td><td>6.6</td><td>24</td><td>95.9</td></tr> <tr><td>5</td><td>10.0</td><td>25</td><td>108.0</td></tr> <tr><td>6</td><td>11.3</td><td>26</td><td>121.7</td></tr> <tr><td>7</td><td>12.7</td><td>27</td><td>137.1</td></tr> <tr><td>8</td><td>14.3</td><td>28</td><td>154.4</td></tr> <tr><td>9</td><td>16.1</td><td>29</td><td>173.9</td></tr> <tr><td>10</td><td>18.1</td><td>30</td><td>195.9</td></tr> <tr><td>11</td><td>20.4</td><td>31</td><td>220.6</td></tr> <tr><td>12</td><td>23.0</td><td>32</td><td>248.5</td></tr> <tr><td>13</td><td>25.9</td><td>33</td><td>279.9</td></tr> <tr><td>14</td><td>29.2</td><td>34</td><td>315.3</td></tr> <tr><td>15</td><td>32.9</td><td>35</td><td>355.1</td></tr> <tr><td>16</td><td>37.0</td><td>36</td><td>400.0</td></tr> <tr><td>17</td><td>41.7</td><td>37</td><td>446.6</td></tr> <tr><td>18</td><td>47.0</td><td>38</td><td>501.2</td></tr> <tr><td>19</td><td>52.9</td><td>39</td><td>571.5</td></tr> <tr><td>20</td><td>Middle response</td><td>59.6</td><td>40</td><td>High response</td><td>642.7</td></tr> </tbody> </table>	Setting value	Machine characteristic		Setting value	Machine characteristic		Response	Guideline for machine resonance frequency [Hz]	Response	Guideline for machine resonance frequency [Hz]	1	Low response	2.7	21	Middle response	67.1	2	3.6	22	75.6	3	4.9	23	85.2	4	6.6	24	95.9	5	10.0	25	108.0	6	11.3	26	121.7	7	12.7	27	137.1	8	14.3	28	154.4	9	16.1	29	173.9	10	18.1	30	195.9	11	20.4	31	220.6	12	23.0	32	248.5	13	25.9	33	279.9	14	29.2	34	315.3	15	32.9	35	355.1	16	37.0	36	400.0	17	41.7	37	446.6	18	47.0	38	501.2	19	52.9	39	571.5	20	Middle response	59.6	40	High response	642.7	16
Setting value	Response	Guideline for machine resonance frequency [Hz]	Setting value	Response	Guideline for machine resonance frequency [Hz]																																																																																																																																																																								
1	Low response	10.0	17	Middle response	67.1																																																																																																																																																																								
2		11.3	18		75.6																																																																																																																																																																								
3		12.7	19		85.2																																																																																																																																																																								
4		14.3	20		95.9																																																																																																																																																																								
5		16.1	21		108.0																																																																																																																																																																								
6		18.1	22		121.7																																																																																																																																																																								
7		20.4	23		137.1																																																																																																																																																																								
8		23.0	24		154.4																																																																																																																																																																								
9		25.9	25		173.9																																																																																																																																																																								
10		29.2	26		195.9																																																																																																																																																																								
11		32.9	27		220.6																																																																																																																																																																								
12		37.0	28		248.5																																																																																																																																																																								
13		41.7	29		279.9																																																																																																																																																																								
14		47.0	30		315.3																																																																																																																																																																								
15		52.9	31		355.1																																																																																																																																																																								
16		Middle response	59.6		32	High response	400.0																																																																																																																																																																						
Setting value	Machine characteristic		Setting value	Machine characteristic																																																																																																																																																																									
	Response	Guideline for machine resonance frequency [Hz]		Response	Guideline for machine resonance frequency [Hz]																																																																																																																																																																								
1	Low response	2.7	21	Middle response	67.1																																																																																																																																																																								
2		3.6	22		75.6																																																																																																																																																																								
3		4.9	23		85.2																																																																																																																																																																								
4		6.6	24		95.9																																																																																																																																																																								
5		10.0	25		108.0																																																																																																																																																																								
6		11.3	26		121.7																																																																																																																																																																								
7		12.7	27		137.1																																																																																																																																																																								
8		14.3	28		154.4																																																																																																																																																																								
9		16.1	29		173.9																																																																																																																																																																								
10		18.1	30		195.9																																																																																																																																																																								
11		20.4	31		220.6																																																																																																																																																																								
12		23.0	32		248.5																																																																																																																																																																								
13		25.9	33		279.9																																																																																																																																																																								
14		29.2	34		315.3																																																																																																																																																																								
15		32.9	35		355.1																																																																																																																																																																								
16		37.0	36		400.0																																																																																																																																																																								
17		41.7	37		446.6																																																																																																																																																																								
18		47.0	38		501.2																																																																																																																																																																								
19		52.9	39		571.5																																																																																																																																																																								
20		Middle response	59.6		40	High response	642.7																																																																																																																																																																						
PA10	<p>In-position range</p> <p>This parameter cannot be used in the speed control mode.</p> <p>Set the range, where in position (INP) is output, in the command pulse unit.</p>	100	PA10	<p>In-position range</p> <p>Set an in-position range per command pulse.</p>	1600																																																																																																																																																																								

Part 3: Review on Replacement of MR-J3- _B_ with MR-J4- _B_

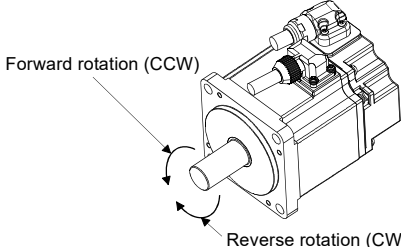
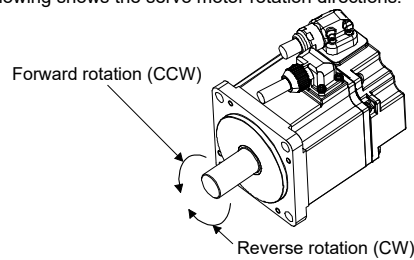
MR-J3- _B_			MR-J4- _B_																									
No.	Name and function	Initial value	No.	Name and function	Initial value																							
PA14	<p>Rotation direction selection</p> <p>This parameter is made valid when power is switched off, then on after setting, or when the controller reset has been performed.</p> <p>Select servo motor rotation direction relative.</p> <table border="1" style="margin-left: 20px;"> <thead> <tr> <th colspan="3">Servo motor rotation direction (Note1)</th> </tr> <tr> <th rowspan="2">[Pr. PA14] setting</th> <th>When positioning address increases (Position control)</th> <th>When positioning address decreases (Position control)</th> </tr> </thead> <tbody> <tr> <td>0</td> <td>CCW</td> <td>CW</td> </tr> <tr> <td>1</td> <td>CW</td> <td>CCW</td> </tr> </tbody> </table> <p>Note 1. The torque generation direction for the torque control.</p> <p>2. The torque generation direction can be set for the slave axis with this parameter by using the master-slave operation function.</p> 	Servo motor rotation direction (Note1)			[Pr. PA14] setting	When positioning address increases (Position control)	When positioning address decreases (Position control)	0	CCW	CW	1	CW	CCW	0	PA14	<p>Rotation direction selection</p> <p>This is used to select a rotation direction.</p> <p>For the setting for the master-slave operation function, refer to "Part 8 section 6.2".</p> <table border="1" style="margin-left: 20px;"> <thead> <tr> <th rowspan="2">Setting value</th> <th colspan="2">Servo motor rotation direction</th> </tr> <tr> <th>Positioning address increase</th> <th>Positioning address decrease</th> </tr> </thead> <tbody> <tr> <td>0</td> <td>CCW</td> <td>CW</td> </tr> <tr> <td>1</td> <td>CW</td> <td>CCW</td> </tr> </tbody> </table> <p>The following shows the servo motor rotation directions.</p> 	Setting value	Servo motor rotation direction		Positioning address increase	Positioning address decrease	0	CCW	CW	1	CW	CCW	0
Servo motor rotation direction (Note1)																												
[Pr. PA14] setting	When positioning address increases (Position control)	When positioning address decreases (Position control)																										
	0	CCW	CW																									
1	CW	CCW																										
Setting value	Servo motor rotation direction																											
	Positioning address increase	Positioning address decrease																										
0	CCW	CW																										
1	CW	CCW																										
PA15	<p>Encoder output pulse</p> <p>This parameter is made valid when power is switched off, then on after setting, or when the controller reset has been performed.</p> <p>Used to set the encoder pulses (A-phase, B-phase) output by the servo amplifier. Set the value 4 times greater than the A-phase or B-phase pulses.</p> <p>You can use [Pr. PC03] to choose the output pulse setting or output division ratio setting.</p> <p>The number of A/B-phase pulses actually output is 1/4 times greater than the preset number of pulses.</p> <p>The maximum output frequency is 4.6 Mpulses/s (after multiplication by 4). Use this parameter within this range.</p> <p>For output pulse designation</p> <p>Set " _ _ 0 _ " (initial value) in [Pr. PC03]</p> <p>Set the number of pulses per servo motor revolution.</p> <p>Output pulse = set value [pulses/rev]</p> <p>For instance, set "5600" to [Pr. PA15], the actually output A/B-phase pulses are as indicated below.</p> $\text{A/B-phase output pulses} = \frac{5600}{4} = 1400 \text{ pulses}$ <p>For output division ratio setting</p> <p>Set " _ _ 1 _ " in [Pr. PC03]</p> <p>The number of pulses per servo motor revolution is divided by the set value.</p> $\text{Output pulse} = \frac{\text{Resolution per servo motor revolution}}{\text{Set value}} \text{ [pulses/rev]}$ <p>For instance, set "8" to [Pr. PA15], the actually output A/B-phase pulses are as indicated below.</p> $\text{A/B-phase output pulses} = \frac{262144}{8} \cdot \frac{1}{4} = 8192 \text{ pulses}$	4000	PA15	<p>Encoder output pulses</p> <p>Set the encoder output pulses from the servo amplifier by using the number of output pulses per revolution, dividing ratio, or electronic gear ratio. (after multiplication by 4)</p> <p>To set a numerator of the electronic gear, select "A-phase/B-phase pulse electronic gear setting (_ _ 3 _)" of "Encoder output pulse setting selection" in [Pr. PC03].</p> <p>The maximum output frequency is 4.6 Mpulses/s. Set the parameter within this range.</p>	4000																							
			PA16	<p>Encoder output pulses 2</p> <p>Set a denominator of the electronic gear for the A/B-phase pulse output. To set a denominator of the electronic gear, select "A-phase/B-phase pulse electronic gear setting (_ _ 3 _)" of "Encoder output pulse setting selection" in [Pr. PC03].</p>	1																							

Part 3: Review on Replacement of MR-J3-_B_ with MR-J4-_B_

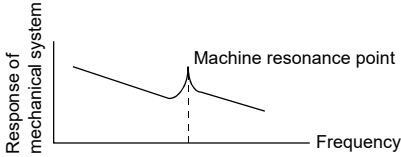
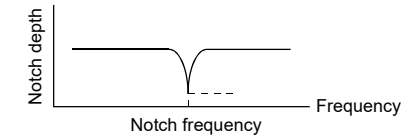
MR-J3-_B_			MR-J4-_B_																																																																																																																																																																																																																																																																																
No.	Name and function	Initial value	No.	Name and function	Initial value																																																																																																																																																																																																																																																																														
PA19	Parameter write inhibit	000Bh	PA19	Parameter writing inhibit	00ABh																																																																																																																																																																																																																																																																														
	<table border="1"> <thead> <tr> <th>[Pr. PA19] setting</th> <th>Setting operation</th> <th>Basic setting [Pr. PA_]</th> <th>Gain/filter [Pr. PB_]</th> <th>Extension setting [Pr. PC_]</th> <th>I/O setting [Pr. PD_]</th> </tr> </thead> <tbody> <tr> <td rowspan="2">0000h</td> <td>Reference</td> <td><input type="radio"/></td> <td>/</td> <td>/</td> <td>/</td> </tr> <tr> <td>Write</td> <td><input type="radio"/></td> <td>/</td> <td>/</td> <td>/</td> </tr> <tr> <td rowspan="2">000Bh (initial value)</td> <td>Reference</td> <td><input type="radio"/></td> <td><input type="radio"/></td> <td><input type="radio"/></td> <td>/</td> </tr> <tr> <td>Write</td> <td><input type="radio"/></td> <td><input type="radio"/></td> <td><input type="radio"/></td> <td>/</td> </tr> <tr> <td rowspan="2">000Ch</td> <td>Reference</td> <td><input type="radio"/></td> <td><input type="radio"/></td> <td><input type="radio"/></td> <td><input type="radio"/></td> </tr> <tr> <td>Write</td> <td><input type="radio"/></td> <td><input type="radio"/></td> <td><input type="radio"/></td> <td><input type="radio"/></td> </tr> <tr> <td rowspan="2">100Bh</td> <td>Reference</td> <td><input type="radio"/></td> <td>/</td> <td>/</td> <td>/</td> </tr> <tr> <td>Write</td> <td>[Pr. PA19] only</td> <td>/</td> <td>/</td> <td>/</td> </tr> <tr> <td rowspan="2">100Ch</td> <td>Reference</td> <td><input type="radio"/></td> <td><input type="radio"/></td> <td><input type="radio"/></td> <td><input type="radio"/></td> </tr> <tr> <td>Write</td> <td>[Pr. PA19] only</td> <td>/</td> <td>/</td> <td>/</td> </tr> </tbody> </table> <p style="text-align: right;">O: Enabled</p>			[Pr. PA19] setting		Setting operation	Basic setting [Pr. PA_]	Gain/filter [Pr. PB_]	Extension setting [Pr. PC_]	I/O setting [Pr. PD_]	0000h	Reference	<input type="radio"/>	/	/	/	Write	<input type="radio"/>	/	/	/	000Bh (initial value)	Reference	<input type="radio"/>	<input type="radio"/>	<input type="radio"/>	/	Write	<input type="radio"/>	<input type="radio"/>	<input type="radio"/>	/	000Ch	Reference	<input type="radio"/>	<input type="radio"/>	<input type="radio"/>	<input type="radio"/>	Write	<input type="radio"/>	<input type="radio"/>	<input type="radio"/>	<input type="radio"/>	100Bh	Reference	<input type="radio"/>	/	/	/	Write	[Pr. PA19] only	/	/	/	100Ch	Reference	<input type="radio"/>	<input type="radio"/>	<input type="radio"/>	<input type="radio"/>	Write	[Pr. PA19] only	/	/	/	<p>Select a reference range and writing range of the parameter.</p> <p>See the table below for the setting value.</p> <p>[Pr. PA19] setting value and reading/writing range</p> <table border="1"> <thead> <tr> <th>PA19</th> <th>Setting operation</th> <th>PA</th> <th>PB</th> <th>PC</th> <th>PD</th> <th>PE</th> <th>PF</th> <th>PL</th> </tr> </thead> <tbody> <tr> <td rowspan="2">Other than below</td> <td>Reading</td> <td><input type="radio"/></td> <td>/</td> <td>/</td> <td>/</td> <td>/</td> <td>/</td> <td>/</td> </tr> <tr> <td>Writing</td> <td><input type="radio"/></td> <td>/</td> <td>/</td> <td>/</td> <td>/</td> <td>/</td> <td>/</td> </tr> <tr> <td rowspan="2">000Ah</td> <td>Reading</td> <td>19 only</td> <td>/</td> <td>/</td> <td>/</td> <td>/</td> <td>/</td> <td>/</td> </tr> <tr> <td>Writing</td> <td>19 only</td> <td>/</td> <td>/</td> <td>/</td> <td>/</td> <td>/</td> <td>/</td> </tr> <tr> <td rowspan="2">000Bh</td> <td>Reading</td> <td><input type="radio"/></td> <td><input type="radio"/></td> <td><input type="radio"/></td> <td>/</td> <td>/</td> <td>/</td> <td>/</td> </tr> <tr> <td>Writing</td> <td><input type="radio"/></td> <td><input type="radio"/></td> <td><input type="radio"/></td> <td>/</td> <td>/</td> <td>/</td> <td>/</td> </tr> <tr> <td rowspan="2">000Ch</td> <td>Reading</td> <td><input type="radio"/></td> <td><input type="radio"/></td> <td><input type="radio"/></td> <td><input type="radio"/></td> <td>/</td> <td>/</td> <td>/</td> </tr> <tr> <td>Writing</td> <td><input type="radio"/></td> <td><input type="radio"/></td> <td><input type="radio"/></td> <td><input type="radio"/></td> <td>/</td> <td>/</td> <td>/</td> </tr> <tr> <td rowspan="2">000Fh</td> <td>Reading</td> <td><input type="radio"/></td> <td><input type="radio"/></td> <td><input type="radio"/></td> <td><input type="radio"/></td> <td><input type="radio"/></td> <td>/</td> <td><input type="radio"/></td> </tr> <tr> <td>Writing</td> <td><input type="radio"/></td> <td><input type="radio"/></td> <td><input type="radio"/></td> <td><input type="radio"/></td> <td><input type="radio"/></td> <td>/</td> <td><input type="radio"/></td> </tr> <tr> <td rowspan="2">00AAh</td> <td>Reading</td> <td><input type="radio"/></td> <td><input type="radio"/></td> <td><input type="radio"/></td> <td><input type="radio"/></td> <td><input type="radio"/></td> <td><input type="radio"/></td> <td>/</td> </tr> <tr> <td>Writing</td> <td><input type="radio"/></td> <td><input type="radio"/></td> <td><input type="radio"/></td> <td><input type="radio"/></td> <td><input type="radio"/></td> <td><input type="radio"/></td> <td>/</td> </tr> <tr> <td rowspan="2">00ABh (initial value)</td> <td>Reading</td> <td><input type="radio"/></td> <td><input type="radio"/></td> <td><input type="radio"/></td> <td><input type="radio"/></td> <td><input type="radio"/></td> <td><input type="radio"/></td> <td><input type="radio"/></td> </tr> <tr> <td>Writing</td> <td><input type="radio"/></td> <td><input type="radio"/></td> <td><input type="radio"/></td> <td><input type="radio"/></td> <td><input type="radio"/></td> <td><input type="radio"/></td> <td><input type="radio"/></td> </tr> <tr> <td rowspan="2">100Bh</td> <td>Reading</td> <td><input type="radio"/></td> <td>/</td> <td>/</td> <td>/</td> <td>/</td> <td>/</td> <td>/</td> </tr> <tr> <td>Writing</td> <td>19 only</td> <td>/</td> <td>/</td> <td>/</td> <td>/</td> <td>/</td> <td>/</td> </tr> <tr> <td rowspan="2">100Ch</td> <td>Reading</td> <td><input type="radio"/></td> <td><input type="radio"/></td> <td><input type="radio"/></td> <td><input type="radio"/></td> <td>/</td> <td>/</td> <td>/</td> </tr> <tr> <td>Writing</td> <td>19 only</td> <td>/</td> <td>/</td> <td>/</td> <td>/</td> <td>/</td> <td>/</td> </tr> <tr> <td rowspan="2">100Fh</td> <td>Reading</td> <td><input type="radio"/></td> <td><input type="radio"/></td> <td><input type="radio"/></td> <td><input type="radio"/></td> <td><input type="radio"/></td> <td>/</td> <td><input type="radio"/></td> </tr> <tr> <td>Writing</td> <td>19 only</td> <td>/</td> <td>/</td> <td>/</td> <td>/</td> <td>/</td> <td>/</td> </tr> <tr> <td rowspan="2">10AAh</td> <td>Reading</td> <td><input type="radio"/></td> <td><input type="radio"/></td> <td><input type="radio"/></td> <td><input type="radio"/></td> <td><input type="radio"/></td> <td><input type="radio"/></td> <td>/</td> </tr> <tr> <td>Writing</td> <td>19 only</td> <td>/</td> <td>/</td> <td>/</td> <td>/</td> <td>/</td> <td>/</td> </tr> <tr> <td rowspan="2">10ABh</td> <td>Reading</td> <td><input type="radio"/></td> <td><input type="radio"/></td> <td><input type="radio"/></td> <td><input type="radio"/></td> <td><input type="radio"/></td> <td><input type="radio"/></td> <td><input type="radio"/></td> </tr> <tr> <td>Writing</td> <td>19 only</td> <td>/</td> <td>/</td> <td>/</td> <td>/</td> <td>/</td> <td>/</td> </tr> </tbody> </table> <p style="text-align: right;">O: Enabled</p>	PA19	Setting operation	PA	PB	PC	PD	PE	PF	PL	Other than below	Reading	<input type="radio"/>	/	/	/	/	/	/	Writing	<input type="radio"/>	/	/	/	/	/	/	000Ah	Reading	19 only	/	/	/	/	/	/	Writing	19 only	/	/	/	/	/	/	000Bh	Reading	<input type="radio"/>	<input type="radio"/>	<input type="radio"/>	/	/	/	/	Writing	<input type="radio"/>	<input type="radio"/>	<input type="radio"/>	/	/	/	/	000Ch	Reading	<input type="radio"/>	<input type="radio"/>	<input type="radio"/>	<input type="radio"/>	/	/	/	Writing	<input type="radio"/>	<input type="radio"/>	<input type="radio"/>	<input type="radio"/>	/	/	/	000Fh	Reading	<input type="radio"/>	<input type="radio"/>	<input type="radio"/>	<input type="radio"/>	<input type="radio"/>	/	<input type="radio"/>	Writing	<input type="radio"/>	<input type="radio"/>	<input type="radio"/>	<input type="radio"/>	<input type="radio"/>	/	<input type="radio"/>	00AAh	Reading	<input type="radio"/>	<input type="radio"/>	<input type="radio"/>	<input type="radio"/>	<input type="radio"/>	<input type="radio"/>	/	Writing	<input type="radio"/>	<input type="radio"/>	<input type="radio"/>	<input type="radio"/>	<input type="radio"/>	<input type="radio"/>	/	00ABh (initial value)	Reading	<input type="radio"/>	<input type="radio"/>	<input type="radio"/>	<input type="radio"/>	<input type="radio"/>	<input type="radio"/>	<input type="radio"/>	Writing	<input type="radio"/>	<input type="radio"/>	<input type="radio"/>	<input type="radio"/>	<input type="radio"/>	<input type="radio"/>	<input type="radio"/>	100Bh	Reading	<input type="radio"/>	/	/	/	/	/	/	Writing	19 only	/	/	/	/	/	/	100Ch	Reading	<input type="radio"/>	<input type="radio"/>	<input type="radio"/>	<input type="radio"/>	/	/	/	Writing	19 only	/	/	/	/	/	/	100Fh	Reading	<input type="radio"/>	<input type="radio"/>	<input type="radio"/>	<input type="radio"/>	<input type="radio"/>	/	<input type="radio"/>	Writing	19 only	/	/	/	/	/	/	10AAh	Reading	<input type="radio"/>	<input type="radio"/>	<input type="radio"/>	<input type="radio"/>	<input type="radio"/>	<input type="radio"/>	/	Writing	19 only	/	/	/	/	/	/	10ABh	Reading	<input type="radio"/>	<input type="radio"/>	<input type="radio"/>	<input type="radio"/>	<input type="radio"/>	<input type="radio"/>	<input type="radio"/>	Writing	19 only	/	/
[Pr. PA19] setting	Setting operation	Basic setting [Pr. PA_]	Gain/filter [Pr. PB_]	Extension setting [Pr. PC_]	I/O setting [Pr. PD_]																																																																																																																																																																																																																																																																														
0000h	Reference	<input type="radio"/>	/	/	/																																																																																																																																																																																																																																																																														
	Write	<input type="radio"/>	/	/	/																																																																																																																																																																																																																																																																														
000Bh (initial value)	Reference	<input type="radio"/>	<input type="radio"/>	<input type="radio"/>	/																																																																																																																																																																																																																																																																														
	Write	<input type="radio"/>	<input type="radio"/>	<input type="radio"/>	/																																																																																																																																																																																																																																																																														
000Ch	Reference	<input type="radio"/>	<input type="radio"/>	<input type="radio"/>	<input type="radio"/>																																																																																																																																																																																																																																																																														
	Write	<input type="radio"/>	<input type="radio"/>	<input type="radio"/>	<input type="radio"/>																																																																																																																																																																																																																																																																														
100Bh	Reference	<input type="radio"/>	/	/	/																																																																																																																																																																																																																																																																														
	Write	[Pr. PA19] only	/	/	/																																																																																																																																																																																																																																																																														
100Ch	Reference	<input type="radio"/>	<input type="radio"/>	<input type="radio"/>	<input type="radio"/>																																																																																																																																																																																																																																																																														
	Write	[Pr. PA19] only	/	/	/																																																																																																																																																																																																																																																																														
PA19	Setting operation	PA	PB	PC	PD	PE	PF	PL																																																																																																																																																																																																																																																																											
Other than below	Reading	<input type="radio"/>	/	/	/	/	/	/																																																																																																																																																																																																																																																																											
	Writing	<input type="radio"/>	/	/	/	/	/	/																																																																																																																																																																																																																																																																											
000Ah	Reading	19 only	/	/	/	/	/	/																																																																																																																																																																																																																																																																											
	Writing	19 only	/	/	/	/	/	/																																																																																																																																																																																																																																																																											
000Bh	Reading	<input type="radio"/>	<input type="radio"/>	<input type="radio"/>	/	/	/	/																																																																																																																																																																																																																																																																											
	Writing	<input type="radio"/>	<input type="radio"/>	<input type="radio"/>	/	/	/	/																																																																																																																																																																																																																																																																											
000Ch	Reading	<input type="radio"/>	<input type="radio"/>	<input type="radio"/>	<input type="radio"/>	/	/	/																																																																																																																																																																																																																																																																											
	Writing	<input type="radio"/>	<input type="radio"/>	<input type="radio"/>	<input type="radio"/>	/	/	/																																																																																																																																																																																																																																																																											
000Fh	Reading	<input type="radio"/>	<input type="radio"/>	<input type="radio"/>	<input type="radio"/>	<input type="radio"/>	/	<input type="radio"/>																																																																																																																																																																																																																																																																											
	Writing	<input type="radio"/>	<input type="radio"/>	<input type="radio"/>	<input type="radio"/>	<input type="radio"/>	/	<input type="radio"/>																																																																																																																																																																																																																																																																											
00AAh	Reading	<input type="radio"/>	<input type="radio"/>	<input type="radio"/>	<input type="radio"/>	<input type="radio"/>	<input type="radio"/>	/																																																																																																																																																																																																																																																																											
	Writing	<input type="radio"/>	<input type="radio"/>	<input type="radio"/>	<input type="radio"/>	<input type="radio"/>	<input type="radio"/>	/																																																																																																																																																																																																																																																																											
00ABh (initial value)	Reading	<input type="radio"/>	<input type="radio"/>	<input type="radio"/>	<input type="radio"/>	<input type="radio"/>	<input type="radio"/>	<input type="radio"/>																																																																																																																																																																																																																																																																											
	Writing	<input type="radio"/>	<input type="radio"/>	<input type="radio"/>	<input type="radio"/>	<input type="radio"/>	<input type="radio"/>	<input type="radio"/>																																																																																																																																																																																																																																																																											
100Bh	Reading	<input type="radio"/>	/	/	/	/	/	/																																																																																																																																																																																																																																																																											
	Writing	19 only	/	/	/	/	/	/																																																																																																																																																																																																																																																																											
100Ch	Reading	<input type="radio"/>	<input type="radio"/>	<input type="radio"/>	<input type="radio"/>	/	/	/																																																																																																																																																																																																																																																																											
	Writing	19 only	/	/	/	/	/	/																																																																																																																																																																																																																																																																											
100Fh	Reading	<input type="radio"/>	<input type="radio"/>	<input type="radio"/>	<input type="radio"/>	<input type="radio"/>	/	<input type="radio"/>																																																																																																																																																																																																																																																																											
	Writing	19 only	/	/	/	/	/	/																																																																																																																																																																																																																																																																											
10AAh	Reading	<input type="radio"/>	<input type="radio"/>	<input type="radio"/>	<input type="radio"/>	<input type="radio"/>	<input type="radio"/>	/																																																																																																																																																																																																																																																																											
	Writing	19 only	/	/	/	/	/	/																																																																																																																																																																																																																																																																											
10ABh	Reading	<input type="radio"/>	<input type="radio"/>	<input type="radio"/>	<input type="radio"/>	<input type="radio"/>	<input type="radio"/>	<input type="radio"/>																																																																																																																																																																																																																																																																											
	Writing	19 only	/	/	/	/	/	/																																																																																																																																																																																																																																																																											
PB01	Adaptive tuning mode (adaptive filter II)	0000h	PB01	Adaptive tuning mode (adaptive filter II)																																																																																																																																																																																																																																																																															
	<p>Select the setting method for filter tuning. Setting this parameter to "___1" (filter tuning mode 1) automatically changes the machine resonance suppression filter 1 [Pr. PB13] and notch shape selection [Pr. PB14].</p>   <p>0 0 0 x: Filter tuning mode selection 0: Filter OFF ([Pr. PB13/PB14] are fixed to the initial values.) 1: Filter tuning mode (Automatically set parameter: [Pr. PB13/PB14]) 2: Manual mode</p> <p>When this parameter is set to "___1", the tuning is completed after positioning is done the predetermined number or times for the predetermined period of time, and the setting changes to "___2". When the filter tuning is not necessary, the setting changes to "___0". When this parameter is set to "___0", the initial values are set to the machine resonance suppression filter 1 and notch shape selection. However, this does not occur when the servo off.</p>			<p>Set the adaptive tuning.</p> <p>___x: Filter tuning mode selection</p> <p>Select the adjustment mode of the machine resonance suppression filter 1. 0: Disabled 1: Automatic setting 2: Manual setting</p> <p>__x__: For manufacturer setting</p> <p>_x__: For manufacturer setting</p> <p>x___: uning accuracy selection 0: Standard 1: High accuracy</p> <p>The frequency is estimated more accurately in the high accuracy mode compared to the standard mode. However, the tuning sound may be larger in the high accuracy mode.</p> <p>This digit is available with servo amplifier with software version C5 or later.</p>																																																																																																																																																																																																																																																																															

Part 3: Review on Replacement of MR-J3- _B_ with MR-J4- _B_

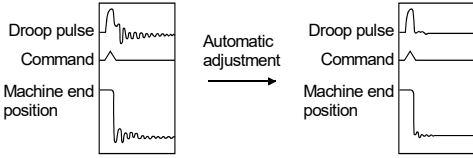
MR-J3- _B_			MR-J4- _B_		
No.	Name and function	Initial value	No.	Name and function	Initial value
PB02	<p>Vibration suppression control tuning mode (advanced vibration suppression control)</p> <p>This parameter cannot be used in the speed control mode.</p> <p>The vibration suppression is valid when the [Pr. PA08] (auto tuning) setting is "___2" or "___3". When PA08 is [Pr. PA08] is "___1", vibration suppression is always invalid.</p> <p>Select the setting method for vibration suppression control tuning. Setting this parameter to "___1" (vibration suppression control tuning mode) automatically changes the vibration suppression control vibration frequency ([Pr. PB19]) and vibration suppression control resonance frequency ([Pr. PB20]) after positioning is done the predetermined number of times.</p>  <p>0 0 0 x:</p> <p>Vibration suppression control tuning mode</p> <p>0: Vibration suppression control OFF ([Pr. PB19/PB20] are fixed to the initial values.)</p> <p>1: Vibration suppression control tuning mode (Advanced vibration suppression control) (Automatically set parameter: [Pr.PB19/PB20])</p> <p>2: Manual mode</p> <p>When this parameter is set to "___1", the tuning is completed after positioning is done the predetermined number or times for the predetermined period of time, and the setting changes to "___2". When the vibration suppression control tuning is not necessary, the setting changes to "___0". When this parameter is set to "___0", the initial values are set to the vibration suppression control vibration frequency and vibration suppression control resonance frequency. However, this does not occur when the servo off.</p>	0000h	PB02	Vibration suppression control tuning mode (advanced vibration suppression control II)	
				<p>This is used to set the vibration suppression control tuning.</p> <p>___ x:</p> <p>Vibration suppression control 1 tuning mode selection</p> <p>Select the tuning mode of the vibration suppression control 1.</p> <p>0: Disabled</p> <p>1: Automatic setting</p> <p>2: Manual setting</p>	0h
				<p>___ x _:</p> <p>Vibration suppression control 2 tuning mode selection</p> <p>Select the tuning mode of the vibration suppression control 2. To enable the digit, select "3 inertia mode (___1)" of "Vibration suppression mode selection" in [Pr. PA24 Function selection A-4].</p> <p>0: Disabled</p> <p>1: Automatic setting</p> <p>2: Manual setting</p>	0h
				<p>_ x _ _:</p> <p>For manufacturer setting</p>	0h
				<p>x _ _ _:</p> <p>For manufacturer setting</p>	0h
PB03	<p>For manufacturer setting</p> <p>Do not change this value by any means.</p>	0	PB03	<p>Torque feedback loop gain</p> <p>This is used to set a torque feedback loop gain in the continuous operation to torque control mode.</p> <p>Decreasing the setting value will also decrease a collision load during continuous operation to torque control mode.</p> <p>Setting a value less than 6 rad/s will be 6 rad/s.</p>	18000
PB04	<p>Feed forward gain</p> <p>This parameter cannot be used in the speed control mode.</p> <p>Set the feed forward gain. When the setting is 100%, the droop pulses during operation at constant speed are nearly zero. However, sudden acceleration/deceleration will increase the overshoot. As a guideline, when the feed forward gain setting is 100%, set 1 s or more as the acceleration/deceleration time constant up to the rated speed.</p>	0	PB04	Same as MR-J3	0
				<p>Feed forward gain</p> <p>Set the feed forward gain.</p> <p>When the setting is 100%, the droop pulses during operation at constant speed are nearly zero. When the super trace control is enabled, constant speed and uniform acceleration/deceleration droop pulses will be almost 0. However, sudden acceleration/deceleration will increase the overshoot. As a guideline, when the feed forward gain setting is 100%, set 1 s or more as the acceleration time constant up to the rated speed.</p>	

Part 3: Review on Replacement of MR-J3- _B_ with MR-J4- _B_

MR-J3- _B_			MR-J4- _B_												
No.	Name and function	Initial value	No.	Name and function	Initial value										
PB06	<p>Load to motor inertia ratio</p> <p>Used to set the ratio of the load inertia moment to the servo motor shaft inertia moment. When auto tuning mode 1 and interpolation mode is selected, the result of auto tuning is automatically used.</p> <p>When [Pr. PA08] is set to "___ 2" or "___ 3", this parameter can be set manually.</p>	7.0	PB06	<p>Same setting as MR-J3</p> <p>Load to motor inertia ratio</p> <p>This is used to set the load to motor inertia ratio. Setting a value considerably different from the actual load moment of inertia may cause an unexpected operation such as an overshoot.</p> <p>The setting of the parameter will be the automatic setting or manual setting depending on the [Pr. PA08] setting. Refer to the following table for details. When the parameter is automatic setting, the value will vary between 0.00 and 100.00.</p> <table border="1"> <thead> <tr> <th>Pr. PA08</th> <th>This parameter</th> </tr> </thead> <tbody> <tr> <td>___ 0 (2 gain adjustment mode 1 (interpolation mode))</td> <td rowspan="2">Automatic setting</td> </tr> <tr> <td>___ 1 (Auto tuning mode 1)</td> </tr> <tr> <td>___ 2 (Auto tuning mode 2)</td> <td rowspan="2">Manual setting</td> </tr> <tr> <td>___ 3 (Manual mode)</td> </tr> <tr> <td>___ 4 (2 gain adjustment mode 2)</td> <td></td> </tr> </tbody> </table>	Pr. PA08	This parameter	___ 0 (2 gain adjustment mode 1 (interpolation mode))	Automatic setting	___ 1 (Auto tuning mode 1)	___ 2 (Auto tuning mode 2)	Manual setting	___ 3 (Manual mode)	___ 4 (2 gain adjustment mode 2)		7.00
Pr. PA08	This parameter														
___ 0 (2 gain adjustment mode 1 (interpolation mode))	Automatic setting														
___ 1 (Auto tuning mode 1)															
___ 2 (Auto tuning mode 2)	Manual setting														
___ 3 (Manual mode)															
___ 4 (2 gain adjustment mode 2)															
PB07	<p>Model loop gain</p> <p>Set the response gain up to the target position.</p> <p>Increase the gain to improve track ability in response to the command.</p> <p>When auto turning mode 1 · 2 is selected, the result of auto tuning is automatically used.</p> <p>When [Pr. PA08] is set to "___ 0" or "___ 3", this parameter can be set manually.</p>	24	PB07	<p>Same setting as MR-J3</p> <p>Model loop gain</p> <p>Set the response gain up to the target position.</p> <p>Increasing the setting value will also increase the response level to the position command but will be liable to generate vibration and noise.</p> <p>The setting of the parameter will be the automatic setting or manual setting depending on the [Pr. PA08] setting. Refer to the following table for details.</p> <table border="1"> <thead> <tr> <th>Pr. PA08</th> <th>This parameter</th> </tr> </thead> <tbody> <tr> <td>___ 0 (2 gain adjustment mode 1 (interpolation mode))</td> <td>Manual setting</td> </tr> <tr> <td>___ 1 (Auto tuning mode 1)</td> <td rowspan="2">Automatic setting</td> </tr> <tr> <td>___ 2 (Auto tuning mode 2)</td> </tr> <tr> <td>___ 3 (Manual mode)</td> <td rowspan="2">Manual setting</td> </tr> <tr> <td>___ 4 (2 gain adjustment mode 2)</td> </tr> </tbody> </table>	Pr. PA08	This parameter	___ 0 (2 gain adjustment mode 1 (interpolation mode))	Manual setting	___ 1 (Auto tuning mode 1)	Automatic setting	___ 2 (Auto tuning mode 2)	___ 3 (Manual mode)	Manual setting	___ 4 (2 gain adjustment mode 2)	15.0
Pr. PA08	This parameter														
___ 0 (2 gain adjustment mode 1 (interpolation mode))	Manual setting														
___ 1 (Auto tuning mode 1)	Automatic setting														
___ 2 (Auto tuning mode 2)															
___ 3 (Manual mode)	Manual setting														
___ 4 (2 gain adjustment mode 2)															
PB08	<p>Position loop gain</p> <p>This parameter cannot be used in the speed control mode.</p> <p>Used to set the gain of the position loop.</p> <p>Set this parameter to increase the position response to level load disturbance. Higher setting increases the response level but is liable to generate vibration and/or noise.</p> <p>When auto tuning mode 1 · 2 and interpolation mode is selected, the result of auto tuning is automatically used.</p> <p>When [Pr. PA08] is set to "___ 3", this parameter can be set manually.</p>	37	PB08	<p>Same as MR-J3</p> <p>Position loop gain</p> <p>This is used to set the gain of the position loop.</p> <p>Set this parameter to increase the position response to level load disturbance.</p> <p>Increasing the setting value will also increase the response level to the load disturbance but will be liable to generate vibration and noise.</p> <p>The setting of the parameter will be the automatic setting or manual setting depending on the [Pr. PA08] setting. Refer to the following table for details.</p> <table border="1"> <thead> <tr> <th>Pr. PA08</th> <th>This parameter</th> </tr> </thead> <tbody> <tr> <td>___ 0 (2 gain adjustment mode 1 (interpolation mode))</td> <td rowspan="2">Automatic setting</td> </tr> <tr> <td>___ 1 (Auto tuning mode 1)</td> </tr> <tr> <td>___ 2 (Auto tuning mode 2)</td> <td rowspan="2">Manual setting</td> </tr> <tr> <td>___ 3 (Manual mode)</td> </tr> <tr> <td>___ 4 (2 gain adjustment mode 2)</td> <td>Automatic setting</td> </tr> </tbody> </table>	Pr. PA08	This parameter	___ 0 (2 gain adjustment mode 1 (interpolation mode))	Automatic setting	___ 1 (Auto tuning mode 1)	___ 2 (Auto tuning mode 2)	Manual setting	___ 3 (Manual mode)	___ 4 (2 gain adjustment mode 2)	Automatic setting	37.0
Pr. PA08	This parameter														
___ 0 (2 gain adjustment mode 1 (interpolation mode))	Automatic setting														
___ 1 (Auto tuning mode 1)															
___ 2 (Auto tuning mode 2)	Manual setting														
___ 3 (Manual mode)															
___ 4 (2 gain adjustment mode 2)	Automatic setting														

Part 3: Review on Replacement of MR-J3- _B_ with MR-J4- _B_

MR-J3- _B_			MR-J4- _B_		
No.	Name and function	Initial value	No.	Name and function	Initial value
PB09	<p>Speed loop gain</p> <p>Used to set the gain of the speed loop.</p> <p>Set this parameter when vibration occurs on machines of low rigidity or large backlash.</p> <p>Higher setting increases the response level but is liable to generate vibration and/or noise.</p> <p>When auto tuning mode 1 * 2, and interpolation mode is selected, the result of auto tuning is automatically used.</p> <p>When [Pr. PA08] is set to " ___ 3", this parameter can be set manually.</p>	823	PB09	<p>Same as MR-J3</p> <p>Speed loop gain</p> <p>This is used to set the gain of the speed loop.</p> <p>Set this parameter when vibration occurs on machines of low rigidity or large backlash. Increasing the setting value will also increase the response level but will be liable to generate vibration and noise.</p> <p>The setting of the parameter will be the automatic setting or manual setting depending on the [Pr. PA08] setting. Refer to the table of [Pr. PB08] for details.</p>	823
PB10	<p>Speed integral compensation</p> <p>Used to set the integral time constant of the speed loop.</p> <p>Lower setting increases the response level but is liable to generate vibration and/or noise.</p> <p>When auto tuning mode 1 * 2 and interpolation mode is selected, the result of auto tuning is automatically used.</p> <p>When [Pr. PA08] is set to " ___ 3", this parameter can be set manually.</p>	33.7	PB10	<p>Same as MR-J3</p> <p>Speed integral compensation</p> <p>This is used to set the integral time constant of the speed loop.</p> <p>Decreasing the setting value will increase the response level but will be liable to generate vibration and noise.</p> <p>The setting of the parameter will be the automatic setting or manual setting depending on the [Pr. PA08] setting. Refer to the table of [Pr. PB08] for details.</p>	33.7
PB11	<p>Speed differential compensation</p> <p>Used to set the differential compensation.</p> <p>When [Pr. PB24] is set to " _ 3 _", this parameter is made valid. When [Pr. PB24] is set to " _ 0 _", this parameter is made valid by instructions of controller.</p>	980	PB11	<p>Same as MR-J3</p> <p>Speed differential compensation</p> <p>This is used to set the differential compensation.</p> <p>To enable the parameter, select "Continuous PID control enabled (_ 3 _)" of "PI-PID switching control selection" in [Pr. PB24].</p>	980
PB12	<p>Overshoot amount compensation</p> <p>This parameter is supported by the servo amplifiers whose software versions are C4 or later. Check the software version using Setup software (SETUP221E).</p> <p>Used to suppress overshoot during position control.</p> <p>Overshoot can be suppressed in machines with high friction.</p> <p>Set a control ratio against the friction torque in percentage unit.</p> <p>When [Pr. PA01] is set to " _ 4 _" or " _ 5 _" and [Pr. PB12] is set to "0", the control ratio against the friction torque is fixed at 5% in the servo amplifier.</p>	0	PB12	<p>Same as MR-J3</p> <p>Overshoot amount compensation</p> <p>This is used to set a dynamic friction torque to rated torque in percentage unit at servo motor rated speed rated speed.</p> <p>When the response level is low or when the torque is limited, the efficiency of the parameter may be lower.</p>	0
PB13	<p>Machine resonance suppression filter 1</p> <p>Set the notch frequency of the machine resonance suppression filter 1.</p> <p>Setting [Pr. PB01] (adaptive tuning mode (adaptive filter II)) to " ___ 1" automatically changes this parameter.</p> <p>When the [Pr. PB01] setting is " ___ 0", the setting of this parameter is ignored.</p>	4500	PB13	<p>Same as MR-J3</p> <p>Machine resonance suppression filter 1</p> <p>Set the notch frequency of the machine resonance suppression filter 1.</p> <p>When "Filter tuning mode selection" is set to "Automatic setting (___ 1)" in [Pr. PB01], this parameter will be adjusted automatically.</p> <p>When "Filter tuning mode selection" is set to "Manual setting (___ 2)" in [Pr. PB01], the setting value will be enabled.</p>	4500

Part 3: Review on Replacement of MR-J3-_B_ with MR-J4-_B_

MR-J3-_B_			MR-J4-_B_		
No.	Name and function	Initial value	No.	Name and function	Initial value
PB14	Notch shape selection 1 Used to selection the machine resonance suppression filter 1. 0 _ x 0: Notch depth selection 0: -40 dB 1: -14 dB 2: -8 dB 3: -4 dB	0000h	PB14	Same as MR-J3	
	Notch shape selection 1 Set the shape of the machine resonance suppression filter 1. When "Filter tuning mode selection" is set to "Automatic setting (_ _ _ 1)" in [Pr. PB01], this parameter will be adjusted automatically. Set manually for the manual setting.			0h	
	_ _ _ x: For manufacturer setting			0h	
	0 x _ 0: Notch width selection 0: $\alpha = 2$ 1: $\alpha = 3$ 2: $\alpha = 4$ 3: $\alpha = 5$ Setting [Pr. PB01] (adaptive tuning mode (adaptive filter II)) to " _ _ _ 1" automatically changes this parameter. When the [Pr. PB01] setting is " _ _ _ 0", the setting of this parameter is ignored.			_ _ x _ : Notch depth selection 0: -40 dB 1: -14 dB 2: -8 dB 3: -4 dB	0h
				_ x _ _ : Notch width selection 0: $\alpha = 2$ 1: $\alpha = 3$ 2: $\alpha = 4$ 3: $\alpha = 5$	0h
				x _ _ _ : For manufacturer setting	0h
PB15	Machine resonance suppression filter 2 Set the notch frequency of the machine resonance suppression filter 2. Set [Pr. PB16] (notch shape selection 2) to " _ _ _ 1" to make this parameter valid.	4500	PB15	Same as MR-J3 Machine resonance suppression filter 2 Set the notch frequency of the machine resonance suppression filter 2. To enable the setting value, select "Enabled (_ _ _ 1)" of "Machine resonance suppression filter 2 selection" in [Pr. PB16].	4500
PB16	Notch shape selection 2 Select the shape of the machine resonance suppression filter 2. 0 _ _ x: Machine resonance suppression filter 2 selection 0: Invalid 1: Valid	0000h	PB16	Same as MR-J3	
	Notch shape selection 2 Set the shape of the machine resonance suppression filter 2.			0h	
	_ _ _ x: Machine resonance suppression filter 2 selection 0: Disabled 1: Enabled			0h	
	0 _ x _ : Notch depth selection 0: -40 dB 1: -14 dB 2: -8 dB 3: -4 dB			_ _ x _ : Notch depth selection 0: -40 dB 1: -14 dB 2: -8 dB 3: -4 dB	0h
	0 x _ _ : Notch width 0: $\alpha = 2$ 1: $\alpha = 3$ 2: $\alpha = 4$ 3: $\alpha = 5$			_ x _ _ : Notch width selection 0: $\alpha = 2$ 1: $\alpha = 3$ 2: $\alpha = 4$ 3: $\alpha = 5$	0h
				x _ _ _ : For manufacturer setting	0h

Part 3: Review on Replacement of MR-J3- _B_ with MR-J4- _B_

MR-J3- _B_			MR-J4- _B_																																																																		
No.	Name and function	Initial value	No.	Name and function	Initial value																																																																
PB17	Automatic setting parameter The value of this parameter is set according to a set value of [Pr. PB06] (Load to motor inertia ratio)		PB17	Shaft resonance suppression filter This is used for setting the shaft resonance suppression filter. This is used to suppress a low-frequency machine vibration. When you select "Automatic setting (_ _ _ 0)" of "Shaft resonance suppression filter selection" in [Pr. PB23], the value will be calculated automatically from the servo motor you use and load to motor inertia ratio. When "Manual setting (_ _ _ 1)" is selected, the setting written to the parameter is used. When "Shaft resonance suppression filter selection" is "Disabled (_ _ _ 2)" in [Pr. PB23], the setting value of this parameter will be disabled. When you select "Enabled (_ _ _ 1)" of "Machine resonance suppression filter 4 selection" in [Pr. PB49], the shaft resonance suppression filter is not available.																																																																	
			_ _ x : Shaft resonance suppression filter setting frequency selection This is used for setting the shaft resonance suppression filter. Refer to table 3.2 for settings. Set the value closest to the frequency you need.	00h																																																																	
			_ x _ _ : Notch depth selection 0: -40 dB 1: -14 dB 2: -8 dB 3: -4 dB	0h																																																																	
			x _ _ _ : For manufacturer setting	0h																																																																	
			Table 3.2 Shaft resonance suppression filter setting frequency selection <table border="1" style="width: 100%; border-collapse: collapse; text-align: center;"> <thead> <tr> <th>Setting value</th> <th>Frequency [Hz]</th> <th>Setting value</th> <th>Frequency [Hz]</th> </tr> </thead> <tbody> <tr><td>_ _ _ 0 0</td><td>Disabled</td><td>_ _ _ 1 0</td><td>562</td></tr> <tr><td>_ _ _ 0 1</td><td>Disabled</td><td>_ _ _ 1 1</td><td>529</td></tr> <tr><td>_ _ _ 0 2</td><td>4500</td><td>_ _ _ 1 2</td><td>500</td></tr> <tr><td>_ _ _ 0 3</td><td>3000</td><td>_ _ _ 1 3</td><td>473</td></tr> <tr><td>_ _ _ 0 4</td><td>2250</td><td>_ _ _ 1 4</td><td>450</td></tr> <tr><td>_ _ _ 0 5</td><td>1800</td><td>_ _ _ 1 5</td><td>428</td></tr> <tr><td>_ _ _ 0 6</td><td>1500</td><td>_ _ _ 1 6</td><td>409</td></tr> <tr><td>_ _ _ 0 7</td><td>1285</td><td>_ _ _ 1 7</td><td>391</td></tr> <tr><td>_ _ _ 0 8</td><td>1125</td><td>_ _ _ 1 8</td><td>375</td></tr> <tr><td>_ _ _ 0 9</td><td>1000</td><td>_ _ _ 1 9</td><td>360</td></tr> <tr><td>_ _ _ 0 A</td><td>900</td><td>_ _ _ 1 A</td><td>346</td></tr> <tr><td>_ _ _ 0 B</td><td>818</td><td>_ _ _ 1 B</td><td>333</td></tr> <tr><td>_ _ _ 0 C</td><td>750</td><td>_ _ _ 1 C</td><td>321</td></tr> <tr><td>_ _ _ 0 D</td><td>692</td><td>_ _ _ 1 D</td><td>310</td></tr> <tr><td>_ _ _ 0 E</td><td>642</td><td>_ _ _ 1 E</td><td>300</td></tr> <tr><td>_ _ _ 0 F</td><td>600</td><td>_ _ _ 1 F</td><td>290</td></tr> </tbody> </table>	Setting value	Frequency [Hz]	Setting value	Frequency [Hz]	_ _ _ 0 0	Disabled	_ _ _ 1 0	562	_ _ _ 0 1	Disabled	_ _ _ 1 1	529	_ _ _ 0 2	4500	_ _ _ 1 2	500	_ _ _ 0 3	3000	_ _ _ 1 3	473	_ _ _ 0 4	2250	_ _ _ 1 4	450	_ _ _ 0 5	1800	_ _ _ 1 5	428	_ _ _ 0 6	1500	_ _ _ 1 6	409	_ _ _ 0 7	1285	_ _ _ 1 7	391	_ _ _ 0 8	1125	_ _ _ 1 8	375	_ _ _ 0 9	1000	_ _ _ 1 9	360	_ _ _ 0 A	900	_ _ _ 1 A	346	_ _ _ 0 B	818	_ _ _ 1 B	333	_ _ _ 0 C	750	_ _ _ 1 C	321	_ _ _ 0 D	692	_ _ _ 1 D	310	_ _ _ 0 E	642	_ _ _ 1 E	300	_ _ _ 0 F	600
Setting value	Frequency [Hz]	Setting value	Frequency [Hz]																																																																		
_ _ _ 0 0	Disabled	_ _ _ 1 0	562																																																																		
_ _ _ 0 1	Disabled	_ _ _ 1 1	529																																																																		
_ _ _ 0 2	4500	_ _ _ 1 2	500																																																																		
_ _ _ 0 3	3000	_ _ _ 1 3	473																																																																		
_ _ _ 0 4	2250	_ _ _ 1 4	450																																																																		
_ _ _ 0 5	1800	_ _ _ 1 5	428																																																																		
_ _ _ 0 6	1500	_ _ _ 1 6	409																																																																		
_ _ _ 0 7	1285	_ _ _ 1 7	391																																																																		
_ _ _ 0 8	1125	_ _ _ 1 8	375																																																																		
_ _ _ 0 9	1000	_ _ _ 1 9	360																																																																		
_ _ _ 0 A	900	_ _ _ 1 A	346																																																																		
_ _ _ 0 B	818	_ _ _ 1 B	333																																																																		
_ _ _ 0 C	750	_ _ _ 1 C	321																																																																		
_ _ _ 0 D	692	_ _ _ 1 D	310																																																																		
_ _ _ 0 E	642	_ _ _ 1 E	300																																																																		
_ _ _ 0 F	600	_ _ _ 1 F	290																																																																		
PB18	Low-pass filter setting Set the low-pass filter. Setting [Pr. PB023] (low-pass filter selection) to " _ _ _ 0 _ " automatically changes this parameter. When [Pr. PB023] is set to " _ _ _ 1 _ ", this parameter can be set manually.	3141	PB18	Same setting as MR-J3	3141																																																																
			Low-pass filter setting Set the low-pass filter. The following shows a relation of a required parameter to this parameter. <table border="1" style="width: 100%; border-collapse: collapse; text-align: center;"> <thead> <tr> <th>[Pr. PB23]</th> <th>[Pr. PB18]</th> </tr> </thead> <tbody> <tr> <td>_ _ _ 0 _ (Initial value)</td> <td>Automatic setting</td> </tr> <tr> <td>_ _ _ 1 _</td> <td>Setting value enabled</td> </tr> <tr> <td>_ _ _ 2 _</td> <td>Setting value disabled</td> </tr> </tbody> </table>	[Pr. PB23]		[Pr. PB18]	_ _ _ 0 _ (Initial value)	Automatic setting	_ _ _ 1 _	Setting value enabled	_ _ _ 2 _	Setting value disabled																																																									
[Pr. PB23]	[Pr. PB18]																																																																				
_ _ _ 0 _ (Initial value)	Automatic setting																																																																				
_ _ _ 1 _	Setting value enabled																																																																				
_ _ _ 2 _	Setting value disabled																																																																				

Part 3: Review on Replacement of MR-J3-_B_ with MR-J4-_B_

MR-J3-_B_			MR-J4-_B_		
No.	Name and function	Initial value	No.	Name and function	Initial value
PB19	Vibration suppression control vibration frequency setting This parameter cannot be used in the speed control mode. Set the vibration frequency for vibration suppression control to suppress low-frequency machine vibration, such as enclosure vibration. Setting [Pr. PB02] (vibration suppression control tuning mode) to "___1" automatically changes this parameter. When [Pr. PB02] is set to "___2", this parameter can be set manually.	100.0	PB19	Same as MR-J3 Vibration suppression control 1 - Vibration frequency Set the vibration frequency for vibration suppression control 1 to suppress low-frequency machine vibration. When "Vibration suppression control 1 tuning mode selection" is set to "Automatic setting (___1)" in [Pr. PB02], this parameter will be set automatically. Set manually for "Manual setting (___2)".	100.0
PB20	Vibration suppression control resonance frequency setting This parameter cannot be used in the speed control mode. Set the resonance frequency for vibration suppression control to suppress low frequency machine vibration, such as enclosure vibration. Setting [Pr. PB02] (vibration suppression control tuning mode) to "___1" automatically changes this parameter. When parameter No.PB02 is set to "___2", this parameter can be set manually.	100.0	PB20	Same as MR-J3 Vibration suppression control 1 - Resonance frequency Set the resonance frequency for vibration suppression control 1 to suppress low-frequency machine vibration. When "Vibration suppression control 1 tuning mode selection" is set to "Automatic setting (___1)" in [Pr. PB02], this parameter will be set automatically. Set manually for "Manual setting (___2)".	100.0
PB21	For manufacturer setting Do not change this value by any means.	0.00	PB21	Vibration suppression control 1 - Vibration frequency damping Set a damping of the vibration frequency for vibration suppression control 1 to suppress low-frequency machine vibration. When "Vibration suppression control 1 tuning mode selection" is set to "Automatic setting (___1)" in [Pr. PB02], this parameter will be set automatically. Set manually for "Manual setting (___2)".	0.00
PB22	For manufacturer setting Do not change this value by any means.	0.00	PB22	Vibration suppression control 1 - Resonance frequency damping Set a damping of the resonance frequency for vibration suppression control 1 to suppress low-frequency machine vibration. When "Vibration suppression control 1 tuning mode selection" is set to "Automatic setting (___1)" in [Pr. PB02], this parameter will be set automatically. Set manually for "Manual setting (___2)".	0.00
PB23	Low-pass filter selection Select the low-pass filter. 0 0 x 0: Low-pass filter selection 0: Automatic setting 1: Manual setting ([Pr. PB18] setting) When automatic setting has been selected, select the filter that has the band width close to the one calculated with $\frac{VG2 \cdot 10}{1 + GD2}$ [rad/s].	0000h	PB23	Same setting as MR-J3 Low-pass filter selection Select the shaft resonance suppression filter and low-pass filter.	
				___x: Shaft resonance suppression filter selection 0: Automatic setting 1: Manual setting 2: Disabled When you select "Enabled (___1)" of "Machine resonance suppression filter 4 selection" in [Pr. PB49], the shaft resonance suppression filter is not available.	0h
				__x__: Low-pass filter selection 0: Automatic setting 1: Manual setting 2: Disabled	0h
				_x__: For manufacturer setting	0h
				x___: For manufacturer setting	0h

Part 3: Review on Replacement of MR-J3- _B_ with MR-J4- _B_

MR-J3- _B_			MR-J4- _B_		
No.	Name and function	Initial value	No.	Name and function	Initial value
PB24	<p>Slight vibration suppression control selection</p> <p>Select the slight vibration suppression control and PI-PID change.</p> <p>When [Pr. PA08] (auto tuning mode) is set to "___ 3", the slight vibration suppression control is made valid. (Slight vibration suppression control cannot be used in the speed control mode.)</p> <p>0 0 _ x:</p> <p>Slight vibration suppression control selection</p> <p>0: Invalid</p> <p>1: Valid</p> <p>0 0 x _:</p> <p>PI-PID control switch over selection</p> <p>0: PI control is valid. (Switching to PID control is possible with instructions of controller.)</p> <p>3: PID control is always valid.</p>	0000h	PB24	Same as MR-J3	
				Slight vibration suppression control	
				Select the slight vibration suppression control and PI-PID switching control.	
				___ x:	0h
				Slight vibration suppression control selection	
0: Disabled					
1: Enabled					
To enable the slight vibration suppression control, select "Manual mode (___ 3)" of "Gain adjustment mode selection" in [Pr. PA08]. Slight vibration suppression control cannot be used in the speed control mode.					
___ x _:	0h				
PI-PID switching control selection					
0: PI control enabled					
(Switching to PID control is possible with commands of servo system controller.)					
3: Continuous PID control enabled					
If the servo motor at a stop is rotated even one pulse due to any external factor, it generates torque to compensate for a position shift. When the servo motor shaft is to be locked mechanically after positioning completion (stop), enabling PID control and completing positioning simultaneously will suppress the unnecessary torque generated to compensate for a position shift.					
_ x _ _:	0h				
For manufacturer setting					
x _ _ _:	0h				
For manufacturer setting					
PB25	<p>For manufacturer setting</p> <p>Do not change this value by any means.</p>	0000h	PB25	Function selection B-1	
				Select enabled/disabled of model adaptive control.	
				This parameter is supported with software version B4 or later.	
				___ x:	0h
				Model adaptive control selection	
0: Enabled (model adaptive control)					
2: Disabled (PID control)					
___ x _:	0h				
For manufacturer setting					
_ x _ _:	0h				
For manufacturer setting					
x _ _ _:	0h				
For manufacturer setting					

Part 3: Review on Replacement of MR-J3- _B_ with MR-J4- _B_

MR-J3- _B_			MR-J4- _B_			
No.	Name and function	Initial value	No.	Name and function	Initial value	
PB26	Gain changing selection Select the gain changing condition.	0000h	PB26	Same setting as MR-J3		
	Gain switching function Select the gain switching condition. Set conditions to enable the gain switching values set in [Pr. PB29] to [Pr. PB36] and [Pr. PB56] to [Pr. PB60].					
	0 0 _ x : Gain changing selection Under any of the following conditions, the gains change on the basis of the [Pr. PB29 to PB34] settings. 0: Invalid 1: Control instructions from a controller. 2: Command frequency ([Pr. PB27] setting) 3: Droop pulse value ([Pr. PB27] setting) 4: Servo motor speed ([Pr. PB27] setting)			0h		
0 0 x _ : Gain changing condition 0: Valid when the control instruction from a controller is ON Valid at equal to or more than the value set in [Pr. PB27] 1: Valid when the control instruction from a controller is OFF Valid at equal to or less than the value set in [Pr. PB27]	0h					
PB27	Gain changing condition Used to set the value of gain changing condition (command frequency, droop pulses, servo motor speed) selected in [Pr. PB26]. The set value unit changes with the changing condition item.	10	PB27	Same setting as MR-J3	10	
				Gain switching condition This is used to set the value of gain switching (command frequency, droop pulses, and servo motor speed) selected in [Pr. PB26]. The set value unit differs depending on the switching condition item.		
PB28	Gain changing time constant Used to set the time constant at which the gains will change in response to the conditions set in [Pr. PB26 and PB27].	1	PB28	Same setting as MR-J3	1	
				Gain switching time constant This is used to set the time constant at which the gains will change in response to the conditions set in [Pr. PB26] and [Pr. PB27].		
PB29	Gain changing load to motor inertia ratio Used to set the load to motor inertia ratio when gain changing is valid. This parameter is made valid when the auto tuning is invalid ([Pr. PA08]: ___ 3).	7.0	PB29	Same as MR-J3	7.00	
				Load to motor inertia ratio after gain switching This is used to set the load to motor inertia ratio when gain switching is enabled. This parameter is enabled only when you select "Manual mode (___ 3)" of "Gain adjustment mode selection" in [Pr. PA08].		
PB30	Gain changing position loop gain This parameter cannot be used in the speed control mode. Set the position loop gain when the gain changing is valid. This parameter is made valid when the auto tuning is invalid ([Pr. PA08]: ___ 3).	37	PB30	Position loop gain after gain switching Set the position loop gain when the gain switching is enabled. When you set a value less than 1.0 rad/s, the value will be the same as [Pr. PB08]. This parameter is enabled only when you select "Manual mode (___ 3)" of "Gain adjustment mode selection" in [Pr. PA08].	0.0	

Part 3: Review on Replacement of MR-J3-_B_ with MR-J4-_B_

MR-J3-_B_			MR-J4-_B_		
No.	Name and function	Initial value	No.	Name and function	Initial value
PB31	<p>Gain changing speed loop gain</p> <p>Set the speed loop gain when the gain changing is valid. This parameter is made valid when the auto tuning is invalid ([Pr. PA08]: ___ 3).</p>	823	PB31	<p>Speed loop gain after gain switching</p> <p>Set the speed loop gain when the gain switching is enabled.</p> <p>When you set a value less than 20 rad/s, the value will be the same as [Pr. PB09].</p> <p>This parameter is enabled only when you select "Manual mode (___ 3)" of "Gain adjustment mode selection" in [Pr. PA08].</p>	0.0
PB32	<p>Gain changing speed integral compensation</p> <p>Set the speed integral compensation when the gain changing is valid.</p> <p>This parameter is made valid when the auto tuning is invalid ([Pr. PA08]: ___ 3)</p>	33.7	PB32	<p>Speed integral compensation after gain switching</p> <p>Set the speed integral compensation when the gain changing is enabled.</p> <p>When you set a value less than 0.1 ms, the value will be the same as [Pr. PB10].</p> <p>This parameter is enabled only when you select "Manual mode (___ 3)" of "Gain adjustment mode selection" in [Pr. PA08].</p>	0.0
PB33	<p>Gain changing vibration suppression control vibration frequency setting</p> <p>This parameter cannot be used in the speed control mode.</p> <p>Set the vibration frequency for vibration suppression control when the gain changing is valid. This parameter is made valid when the [Pr. PB02] setting is "___ 2" and the [Pr. PB26] setting is "___ 1". When using the vibration suppression control gain changing, always execute the changing after the servo motor has stopped.</p>	100.0	PB33	<p>Vibration suppression control 1 - Vibration frequency after gain switching</p> <p>Set the vibration frequency for vibration suppression control 1 when the gain switching is enabled.</p> <p>When you set a value less than 0.1 Hz, the value will be the same as [Pr. PB19].</p> <p>This parameter will be enabled only when the following conditions are fulfilled.</p> <ul style="list-style-type: none"> ▪ "Gain adjustment mode selection" in [Pr. PA08] is "Manual mode (___ 3)". ▪ "Vibration suppression control 1 tuning mode selection" in [Pr. PB02] is "Manual setting (___ 2)". ▪ "Gain switching selection" in [Pr. PB26] is "Control command from controller is enabled (___ 1)". <p>Switching during driving may cause a shock. Be sure to switch them after the servo motor stops.</p>	0.0
PB34	<p>Gain changing vibration suppression control resonance frequency setting</p> <p>This parameter cannot be used in the speed control mode.</p> <p>Set the resonance frequency for vibration suppression control when the gain changing is valid. This parameter is made valid when the [Pr. PB02] setting is "___ 2" and the [Pr. PB26] setting is "___ 1".</p> <p>When using the vibration suppression control gain changing, always execute the changing after the servo motor has stopped.</p>	100.0	PB34	<p>Vibration suppression control 1 - Resonance frequency after gain switching</p> <p>Set the resonance frequency for vibration suppression control 1 when the gain switching is enabled.</p> <p>When you set a value less than 0.1 Hz, the value will be the same as [Pr. PB20].</p> <p>This parameter will be enabled only when the following conditions are fulfilled.</p> <ul style="list-style-type: none"> ▪ "Gain adjustment mode selection" in [Pr. PA08] is "Manual mode (___ 3)". ▪ "Vibration suppression control 1 tuning mode selection" in [Pr. PB02] is "Manual setting (___ 2)". ▪ "Gain switching selection" in [Pr. PB26] is "Control command from controller is enabled (___ 1)". <p>Switching during driving may cause a shock. Be sure to switch them after the servo motor stops.</p>	0.0

Part 3: Review on Replacement of MR-J3-__B__ with MR-J4-__B__

MR-J3-__B__			MR-J4-__B__		
No.	Name and function	Initial value	No.	Name and function	Initial value
PB35	For manufacturer setting Do not change this value by any means.	0.00	PB35	Vibration suppression control 1 - Vibration frequency damping after gain switching Set a damping of the vibration frequency for vibration suppression control 1 when the gain switching is enabled. This parameter will be enabled only when the following conditions are fulfilled. <ul style="list-style-type: none"> ▪ "Gain adjustment mode selection" in [Pr. PA08] is "Manual mode (___ 3)". ▪ "Vibration suppression control 1 tuning mode selection" in [Pr. PB02] is "Manual setting (___ 2)". ▪ "Gain switching selection" in [Pr. PB26] is "Control command from controller is enabled (___ 1)". Switching during driving may cause a shock. Be sure to switch them after the servo motor stops.	0.00
PB36	For manufacturer setting Do not change this value by any means.	0.00	PB36	Vibration suppression control 1 - Resonance frequency damping after gain switching Set a damping of the resonance frequency for vibration suppression control 1 when the gain switching is enabled. This parameter will be enabled only when the following conditions are fulfilled. <ul style="list-style-type: none"> ▪ "Gain adjustment mode selection" in [Pr. PA08] is "Manual mode (___ 3)". ▪ "Vibration suppression control 1 tuning mode selection" in [Pr. PB02] is "Manual setting (___ 2)". ▪ "Gain switching selection" in [Pr. PB26] is "Control command from controller is enabled (___ 1)". Switching during driving may cause a shock. Be sure to switch them after the servo motor stops.	0.00

Part 3: Review on Replacement of MR-J3-_B_ with MR-J4-_B_

MR-J3-_B_			MR-J4-_B_																																																																																																																																																																																																									
No.	Name and function	Initial value	No.	Name and function	Initial value																																																																																																																																																																																																							
PB45	Vibration suppression control filter 2 Used to set the vibration suppression control filter 2. By setting this parameter, machine end vibration, such as workpiece end vibration and base shake, can be suppressed.	0000h	PB45	Same as MR-J3																																																																																																																																																																																																								
	Command notch filter Set the command notch filter.																																																																																																																																																																																																											
	__ x x: Command notch filter setting frequency selection Refer to table 3.3 for the relation of setting values to frequency.			00h																																																																																																																																																																																																								
	_ x __ : Notch depth selection Refer to table 3.4 for details.			0h																																																																																																																																																																																																								
	x __ __ : For manufacturer setting			0h																																																																																																																																																																																																								
	<p>0 0 x x: Vibration suppression control filter 2 setting frequency selection (Note)</p> <table border="1"> <thead> <tr> <th>Setting value</th> <th>Frequency [Hz]</th> </tr> </thead> <tbody> <tr> <td>0</td> <td>Invalid</td> </tr> <tr> <td>1</td> <td>2250</td> </tr> <tr> <td>to</td> <td>to</td> </tr> <tr> <td>5F</td> <td>4.5</td> </tr> </tbody> </table>	Setting value	Frequency [Hz]	0	Invalid	1	2250	to	to	5F	4.5																																																																																																																																																																																																	
Setting value	Frequency [Hz]																																																																																																																																																																																																											
0	Invalid																																																																																																																																																																																																											
1	2250																																																																																																																																																																																																											
to	to																																																																																																																																																																																																											
5F	4.5																																																																																																																																																																																																											
	<p>0 x 0 0: Notch depth selection</p> <table border="1"> <thead> <tr> <th>Setting value</th> <th>Depth</th> </tr> </thead> <tbody> <tr> <td>0</td> <td>-40dB</td> </tr> <tr> <td>to</td> <td>to</td> </tr> <tr> <td>F</td> <td>-0.6dB</td> </tr> </tbody> </table> <p>Note. This parameter is supported by the servo amplifiers whose software versions are C4 or later. Check the software version using Setup software (SETUP221E).</p>	Setting value	Depth	0	-40dB	to	to	F	-0.6dB																																																																																																																																																																																																			
Setting value	Depth																																																																																																																																																																																																											
0	-40dB																																																																																																																																																																																																											
to	to																																																																																																																																																																																																											
F	-0.6dB																																																																																																																																																																																																											
				<p>Table 3.3 Command notch filter setting frequency selection</p> <table border="1"> <thead> <tr> <th>Setting value</th> <th>Frequency [Hz]</th> <th>Setting value</th> <th>Frequency [Hz]</th> <th>Setting value</th> <th>Frequency [Hz]</th> </tr> </thead> <tbody> <tr><td>__ 0 0</td><td>Disabled</td><td>__ 2 0</td><td>70</td><td>__ 4 0</td><td>17.6</td></tr> <tr><td>__ 0 1</td><td>2250</td><td>__ 2 1</td><td>66</td><td>__ 4 1</td><td>16.5</td></tr> <tr><td>__ 0 2</td><td>1125</td><td>__ 2 2</td><td>62</td><td>__ 4 2</td><td>15.6</td></tr> <tr><td>__ 0 3</td><td>750</td><td>__ 2 3</td><td>59</td><td>__ 4 3</td><td>14.8</td></tr> <tr><td>__ 0 4</td><td>562</td><td>__ 2 4</td><td>56</td><td>__ 4 4</td><td>14.1</td></tr> <tr><td>__ 0 5</td><td>450</td><td>__ 2 5</td><td>53</td><td>__ 4 5</td><td>13.4</td></tr> <tr><td>__ 0 6</td><td>375</td><td>__ 2 6</td><td>51</td><td>__ 4 6</td><td>12.8</td></tr> <tr><td>__ 0 7</td><td>321</td><td>__ 2 7</td><td>48</td><td>__ 4 7</td><td>12.2</td></tr> <tr><td>__ 0 8</td><td>281</td><td>__ 2 8</td><td>46</td><td>__ 4 8</td><td>11.7</td></tr> <tr><td>__ 0 9</td><td>250</td><td>__ 2 9</td><td>45</td><td>__ 4 9</td><td>11.3</td></tr> <tr><td>__ 0 A</td><td>225</td><td>__ 2 A</td><td>43</td><td>__ 4 A</td><td>10.8</td></tr> <tr><td>__ 0 B</td><td>204</td><td>__ 2 B</td><td>41</td><td>__ 4 B</td><td>10.4</td></tr> <tr><td>__ 0 C</td><td>187</td><td>__ 2 C</td><td>40</td><td>__ 4 C</td><td>10</td></tr> <tr><td>__ 0 D</td><td>173</td><td>__ 2 D</td><td>38</td><td>__ 4 D</td><td>9.7</td></tr> <tr><td>__ 0 E</td><td>160</td><td>__ 2 E</td><td>37</td><td>__ 4 E</td><td>9.4</td></tr> <tr><td>__ 0 F</td><td>150</td><td>__ 2 F</td><td>36</td><td>__ 4 F</td><td>9.1</td></tr> <tr><td>__ 1 0</td><td>140</td><td>__ 3 0</td><td>35.2</td><td>__ 5 0</td><td>8.8</td></tr> <tr><td>__ 1 1</td><td>132</td><td>__ 3 1</td><td>33.1</td><td>__ 5 1</td><td>8.3</td></tr> <tr><td>__ 1 2</td><td>125</td><td>__ 3 2</td><td>31.3</td><td>__ 5 2</td><td>7.8</td></tr> <tr><td>__ 1 3</td><td>118</td><td>__ 3 3</td><td>29.6</td><td>__ 5 3</td><td>7.4</td></tr> <tr><td>__ 1 4</td><td>112</td><td>__ 3 4</td><td>28.1</td><td>__ 5 4</td><td>7.0</td></tr> <tr><td>__ 1 5</td><td>107</td><td>__ 3 5</td><td>26.8</td><td>__ 5 5</td><td>6.7</td></tr> <tr><td>__ 1 6</td><td>102</td><td>__ 3 6</td><td>25.6</td><td>__ 5 6</td><td>6.4</td></tr> <tr><td>__ 1 7</td><td>97</td><td>__ 3 7</td><td>24.5</td><td>__ 5 7</td><td>6.1</td></tr> <tr><td>__ 1 8</td><td>93</td><td>__ 3 8</td><td>23.4</td><td>__ 5 8</td><td>5.9</td></tr> <tr><td>__ 1 9</td><td>90</td><td>__ 3 9</td><td>22.5</td><td>__ 5 9</td><td>5.6</td></tr> <tr><td>__ 1 A</td><td>86</td><td>__ 3 A</td><td>21.6</td><td>__ 5 A</td><td>5.4</td></tr> <tr><td>__ 1 B</td><td>83</td><td>__ 3 B</td><td>20.8</td><td>__ 5 B</td><td>5.2</td></tr> <tr><td>__ 1 C</td><td>80</td><td>__ 3 C</td><td>20.1</td><td>__ 5 C</td><td>5.0</td></tr> <tr><td>__ 1 D</td><td>77</td><td>__ 3 D</td><td>19.4</td><td>__ 5 D</td><td>4.9</td></tr> <tr><td>__ 1 E</td><td>75</td><td>__ 3 E</td><td>18.8</td><td>__ 5 E</td><td>4.7</td></tr> <tr><td>__ 1 F</td><td>72</td><td>__ 3 F</td><td>18.2</td><td>__ 5 F</td><td>4.5</td></tr> </tbody> </table>	Setting value	Frequency [Hz]	Setting value	Frequency [Hz]	Setting value	Frequency [Hz]	__ 0 0	Disabled	__ 2 0	70	__ 4 0	17.6	__ 0 1	2250	__ 2 1	66	__ 4 1	16.5	__ 0 2	1125	__ 2 2	62	__ 4 2	15.6	__ 0 3	750	__ 2 3	59	__ 4 3	14.8	__ 0 4	562	__ 2 4	56	__ 4 4	14.1	__ 0 5	450	__ 2 5	53	__ 4 5	13.4	__ 0 6	375	__ 2 6	51	__ 4 6	12.8	__ 0 7	321	__ 2 7	48	__ 4 7	12.2	__ 0 8	281	__ 2 8	46	__ 4 8	11.7	__ 0 9	250	__ 2 9	45	__ 4 9	11.3	__ 0 A	225	__ 2 A	43	__ 4 A	10.8	__ 0 B	204	__ 2 B	41	__ 4 B	10.4	__ 0 C	187	__ 2 C	40	__ 4 C	10	__ 0 D	173	__ 2 D	38	__ 4 D	9.7	__ 0 E	160	__ 2 E	37	__ 4 E	9.4	__ 0 F	150	__ 2 F	36	__ 4 F	9.1	__ 1 0	140	__ 3 0	35.2	__ 5 0	8.8	__ 1 1	132	__ 3 1	33.1	__ 5 1	8.3	__ 1 2	125	__ 3 2	31.3	__ 5 2	7.8	__ 1 3	118	__ 3 3	29.6	__ 5 3	7.4	__ 1 4	112	__ 3 4	28.1	__ 5 4	7.0	__ 1 5	107	__ 3 5	26.8	__ 5 5	6.7	__ 1 6	102	__ 3 6	25.6	__ 5 6	6.4	__ 1 7	97	__ 3 7	24.5	__ 5 7	6.1	__ 1 8	93	__ 3 8	23.4	__ 5 8	5.9	__ 1 9	90	__ 3 9	22.5	__ 5 9	5.6	__ 1 A	86	__ 3 A	21.6	__ 5 A	5.4	__ 1 B	83	__ 3 B	20.8	__ 5 B	5.2	__ 1 C	80	__ 3 C	20.1	__ 5 C	5.0	__ 1 D	77	__ 3 D	19.4	__ 5 D	4.9	__ 1 E	75	__ 3 E	18.8	__ 5 E	4.7	__ 1 F	72	__ 3 F	18.2	__ 5 F	4.5		
Setting value	Frequency [Hz]	Setting value	Frequency [Hz]	Setting value	Frequency [Hz]																																																																																																																																																																																																							
__ 0 0	Disabled	__ 2 0	70	__ 4 0	17.6																																																																																																																																																																																																							
__ 0 1	2250	__ 2 1	66	__ 4 1	16.5																																																																																																																																																																																																							
__ 0 2	1125	__ 2 2	62	__ 4 2	15.6																																																																																																																																																																																																							
__ 0 3	750	__ 2 3	59	__ 4 3	14.8																																																																																																																																																																																																							
__ 0 4	562	__ 2 4	56	__ 4 4	14.1																																																																																																																																																																																																							
__ 0 5	450	__ 2 5	53	__ 4 5	13.4																																																																																																																																																																																																							
__ 0 6	375	__ 2 6	51	__ 4 6	12.8																																																																																																																																																																																																							
__ 0 7	321	__ 2 7	48	__ 4 7	12.2																																																																																																																																																																																																							
__ 0 8	281	__ 2 8	46	__ 4 8	11.7																																																																																																																																																																																																							
__ 0 9	250	__ 2 9	45	__ 4 9	11.3																																																																																																																																																																																																							
__ 0 A	225	__ 2 A	43	__ 4 A	10.8																																																																																																																																																																																																							
__ 0 B	204	__ 2 B	41	__ 4 B	10.4																																																																																																																																																																																																							
__ 0 C	187	__ 2 C	40	__ 4 C	10																																																																																																																																																																																																							
__ 0 D	173	__ 2 D	38	__ 4 D	9.7																																																																																																																																																																																																							
__ 0 E	160	__ 2 E	37	__ 4 E	9.4																																																																																																																																																																																																							
__ 0 F	150	__ 2 F	36	__ 4 F	9.1																																																																																																																																																																																																							
__ 1 0	140	__ 3 0	35.2	__ 5 0	8.8																																																																																																																																																																																																							
__ 1 1	132	__ 3 1	33.1	__ 5 1	8.3																																																																																																																																																																																																							
__ 1 2	125	__ 3 2	31.3	__ 5 2	7.8																																																																																																																																																																																																							
__ 1 3	118	__ 3 3	29.6	__ 5 3	7.4																																																																																																																																																																																																							
__ 1 4	112	__ 3 4	28.1	__ 5 4	7.0																																																																																																																																																																																																							
__ 1 5	107	__ 3 5	26.8	__ 5 5	6.7																																																																																																																																																																																																							
__ 1 6	102	__ 3 6	25.6	__ 5 6	6.4																																																																																																																																																																																																							
__ 1 7	97	__ 3 7	24.5	__ 5 7	6.1																																																																																																																																																																																																							
__ 1 8	93	__ 3 8	23.4	__ 5 8	5.9																																																																																																																																																																																																							
__ 1 9	90	__ 3 9	22.5	__ 5 9	5.6																																																																																																																																																																																																							
__ 1 A	86	__ 3 A	21.6	__ 5 A	5.4																																																																																																																																																																																																							
__ 1 B	83	__ 3 B	20.8	__ 5 B	5.2																																																																																																																																																																																																							
__ 1 C	80	__ 3 C	20.1	__ 5 C	5.0																																																																																																																																																																																																							
__ 1 D	77	__ 3 D	19.4	__ 5 D	4.9																																																																																																																																																																																																							
__ 1 E	75	__ 3 E	18.8	__ 5 E	4.7																																																																																																																																																																																																							
__ 1 F	72	__ 3 F	18.2	__ 5 F	4.5																																																																																																																																																																																																							
				<p>Table 3.4 Notch depth selection</p> <table border="1"> <thead> <tr> <th>Setting value</th> <th>Depth [dB]</th> <th>Setting value</th> <th>Depth [dB]</th> </tr> </thead> <tbody> <tr><td>__ 0 __</td><td>-40.0</td><td>__ 8 __</td><td>-6.0</td></tr> <tr><td>__ 1 __</td><td>-24.1</td><td>__ 9 __</td><td>-5.0</td></tr> <tr><td>__ 2 __</td><td>-18.1</td><td>__ A __</td><td>-4.1</td></tr> <tr><td>__ 3 __</td><td>-14.5</td><td>__ B __</td><td>-3.3</td></tr> <tr><td>__ 4 __</td><td>-12.0</td><td>__ C __</td><td>-2.5</td></tr> <tr><td>__ 5 __</td><td>-10.1</td><td>__ D __</td><td>-1.8</td></tr> <tr><td>__ 6 __</td><td>-8.5</td><td>__ E __</td><td>-1.2</td></tr> <tr><td>__ 7 __</td><td>-7.2</td><td>__ F __</td><td>-0.6</td></tr> </tbody> </table>	Setting value	Depth [dB]	Setting value	Depth [dB]	__ 0 __	-40.0	__ 8 __	-6.0	__ 1 __	-24.1	__ 9 __	-5.0	__ 2 __	-18.1	__ A __	-4.1	__ 3 __	-14.5	__ B __	-3.3	__ 4 __	-12.0	__ C __	-2.5	__ 5 __	-10.1	__ D __	-1.8	__ 6 __	-8.5	__ E __	-1.2	__ 7 __	-7.2	__ F __	-0.6																																																																																																																																																																				
Setting value	Depth [dB]	Setting value	Depth [dB]																																																																																																																																																																																																									
__ 0 __	-40.0	__ 8 __	-6.0																																																																																																																																																																																																									
__ 1 __	-24.1	__ 9 __	-5.0																																																																																																																																																																																																									
__ 2 __	-18.1	__ A __	-4.1																																																																																																																																																																																																									
__ 3 __	-14.5	__ B __	-3.3																																																																																																																																																																																																									
__ 4 __	-12.0	__ C __	-2.5																																																																																																																																																																																																									
__ 5 __	-10.1	__ D __	-1.8																																																																																																																																																																																																									
__ 6 __	-8.5	__ E __	-1.2																																																																																																																																																																																																									
__ 7 __	-7.2	__ F __	-0.6																																																																																																																																																																																																									

Part 3: Review on Replacement of MR-J3- _B_ with MR-J4- _B_

MR-J3- _B_			MR-J4- _B_																							
No.	Name and function	Initial value	No.	Name and function	Initial value																					
PC01	<p>Error excessive alarm level</p> <p>This parameter cannot be used in the speed control mode or in the torque control mode.</p> <p>Set error excessive alarm level with rotation amount of servo motor.</p> <p>Note 1. Setting can be changed in [Pr. PC06].</p> <p>2. For a servo amplifier with software version of B2 or later, reactivating the power supply to enable the setting value is not necessary. For a servo amplifier with software version of earlier than B2, reactivating the power supply is required to enable the setting value.</p> <p>Check the software version using Setup software (SETUP221E).</p>	3	PC01	<p>Error excessive alarm level</p> <p>Set an error excessive alarm level.</p> <p>Set this per rev. for rotary servo motors and direct drive motors. Setting "0" will be 3 rev. Setting over 200 rev will be clamped with 200 rev.</p>	0																					
PC02	<p>Electromagnetic brake sequence output</p> <p>Used to set the delay time (Tb) between electronic brake interlock (MBR) and the base drive circuit is shut-off.</p>	0	PC02	<p>Same as MR-J3</p> <p>Electromagnetic brake sequence output</p> <p>This is used to set the delay time between MBR (Electromagnetic brake interlock) and the base drive circuit is shut-off.</p>	0																					
PC03	<p>Encoder output pulse selection</p> <p>Use to select the, encoder output pulse direction and encoder output pulse setting.</p>	0000h	PC03	<p>Same setting as MR-J3</p> <p>Encoder output pulse selection</p> <p>This is used to select the encoder pulse direction and encoder output pulse setting.</p>	0h																					
	<p>0 0 _ x:</p> <p>Encoder output pulse phase changing</p> <p>Changes the phases of A, B-phase encoder pulses output.</p> <table border="1" style="width: 100%; text-align: center;"> <thead> <tr> <th rowspan="2">Setting value</th> <th colspan="2">Servo motor rotation direction</th> </tr> <tr> <th>CCW</th> <th>CW</th> </tr> </thead> <tbody> <tr> <td>0</td> <td>A-phase B-phase </td> <td>A-phase B-phase </td> </tr> <tr> <td>1</td> <td>A-phase B-phase </td> <td>A-phase B-phase </td> </tr> </tbody> </table>		Setting value	Servo motor rotation direction		CCW	CW	0	A-phase B-phase	A-phase B-phase	1	A-phase B-phase	A-phase B-phase	<p>___ x:</p> <p>Encoder output pulse phase selection</p> <p>0: Increasing A-phase 90° in CCW or positive direction</p> <p>1: Increasing A-phase 90° in CW or negative direction</p> <table border="1" style="width: 100%; text-align: center;"> <thead> <tr> <th rowspan="2">Setting value</th> <th colspan="2">Servo motor rotation direction</th> </tr> <tr> <th>CCW or positive direction</th> <th>CW or negative direction</th> </tr> </thead> <tbody> <tr> <td>0</td> <td>A-phase B-phase </td> <td>A-phase B-phase </td> </tr> <tr> <td>1</td> <td>A-phase B-phase </td> <td>A-phase B-phase </td> </tr> </tbody> </table>	Setting value	Servo motor rotation direction		CCW or positive direction	CW or negative direction	0	A-phase B-phase	A-phase B-phase	1	A-phase B-phase	A-phase B-phase	
	Setting value			Servo motor rotation direction																						
CCW		CW																								
0	A-phase B-phase	A-phase B-phase																								
1	A-phase B-phase	A-phase B-phase																								
Setting value	Servo motor rotation direction																									
	CCW or positive direction	CW or negative direction																								
0	A-phase B-phase	A-phase B-phase																								
1	A-phase B-phase	A-phase B-phase																								
<p>0 0 x _:</p> <p>Encoder output pulse setting selection</p> <p>0: Output pulse designation</p> <p>1: Division ratio setting</p>	<p>__ x _:</p> <p>Encoder output pulse setting selection</p> <p>0: Output pulse setting</p> <p>When " _ 1 0 _ " is set to this parameter, [AL. 37 Parameter error] will occur.</p> <p>1: Division ratio setting</p> <p>3: A-phase/B-phase pulse electronic gear setting</p> <p>4: A/B-phase pulse through output setting</p>	0h																								
				<p>_ x _ _:</p> <p>Selection of the encoders for encoder output pulse</p> <p>Select an encoder used for the encoder output pulses which the servo amplifier outputs.</p> <p>0: Servo motor encoder</p> <p>1: Load-side encoder</p> <p>When " _ 1 0 _ " is set to this parameter, [AL. 37 Parameter error] will occur.</p>	0h																					
				<p>x _ _ _:</p> <p>For manufacturer setting</p>	0h																					

Part 3: Review on Replacement of MR-J3-__B__ with MR-J4-__B__

MR-J3-__B__			MR-J4-__B__			
No.	Name and function	Initial value	No.	Name and function	Initial value	
PC04	<p>Function selection C-1 Select the encoder cable communication system selection.</p> <p>x 0 0 0: Encoder cable communication system selection 0: Two-wire type 1: Four-wire type Incorrect setting will result in an [AL.16 encoder alarm 1].</p>	0000h	PC04	Same as MR-J3		
				Function selection C-1 Select the encoder cable communication method selection.		
				___x: For manufacturer setting		0h
				__x_: For manufacturer setting		0h
				_x__: For manufacturer setting		0h
PC05	<p>Function selection C-2 Motor-less operation select.</p> <p>0 0 0 x: Motor-less operation select. 0: Valid 1: Invalid</p>	0000h	PC05	Same setting as MR-J3		
				Function selection C-2 Set the motor-less operation.		
				___x: Motor-less operation selection 0: Disabled 1: Enabled		0h
				__x_: For manufacturer setting		0h
				_x__: For manufacturer setting		0h
PC06	<p>Function selection C-3 This parameter cannot be used in the speed control mode or in the torque control mode. Select the error excessive alarm level setting for [Pr. PC01]</p> <p>x 0 0 0: Error excessive alarm level setting selection 0: 1 [rev] unit 1: 0.1 [rev] unit 2: 0.01 [rev] unit 3: 0.001 [rev] unit</p> <p>This parameter is available to software version B1 or later. Check the software version using Setup software (SETUP221E).</p>	0000h	PC06	Same as MR-J3		
				Function selection C-3 Select units for error excessive alarm level setting with [Pr. PC01]. The parameter is not available in the speed control mode and torque control mode.		
				___x: For manufacturer setting		0h
				__x_: For manufacturer setting		0h
				_x__: For manufacturer setting		0h
				x ___: Error excessive alarm/error excessive warning level unit selection 0: Per 1 rev 1: Per 0.1 rev 2: Per 0.01 rev 3: Per 0.001 rev	0h	

Part 3: Review on Replacement of MR-J3-_B_ with MR-J4-_B_

MR-J3-_B_			MR-J4-_B_		
No.	Name and function	Initial value	No.	Name and function	Initial value
PC07	Zero speed Used to set the output range of the zero speed detection (ZSP). Zero speed detection (ZSP) has hysteresis width of 20 r/min	50	PC07	Same as MR-J3 Zero speed Used to set the output range of ZSP (Zero speed detection). ZSP (Zero speed detection) has hysteresis of 20 r/min.	50
PC08	For manufacturer setting Do not change this value by any means.	0	PC08	Overspeed alarm detection level This is used to set an overspeed alarm detection level. When you set a value more than "servo motor maximum speed × 120%" the set value will be clamped. When you set "0", the value of "servo motor maximum speed × 120%" will be set.	0
PC09	Analog monitor 1 output Used to selection the signal provided to the analog monitor 1 (MO1) output. 0 0 0 x: Analog monitor 1 (MO1) output selection 0: Servo motor speed (± 8 V/max. speed) 1: Torque (±8 V/max. torque) 2: Servo motor speed (+8 V/max. speed) 3: Torque (+8 V/max. torque) 4: Current command (±8 V/max. current command) 5: Speed command (±8 V/max. current command) 6: Droop pulses (±10 V/100 pulses) 7: Droop pulses (±10 V/1000 pulses) 8: Droop pulses (±10 V/10000 pulses) 9: Droop pulses (±10 V/100000 pulses) A: Feedback position (±10 V/1 Mpulse) B: Feedback position (±10 V/10 Mpulses) C: Feedback position (±10 V/100 Mpulses) D: Bus voltage (+8 V/400 V) E: Speed command 2 (±8 V/max. current command)	0000h	PC09	Analog monitor 1 output Select a signal to output to MO1 (Analog monitor 1).	
			__ x x: Analog monitor 1 output selection 0 0: servo motor speed (±8 V/max. speed) 0 1: Torque (±8 V/max. torque) 0 2: servo motor speed (+8 V/max. speed) 0 3: Torque (+8 V/max. torque) 0 4: Current command (±8 V/max. current command) 0 5: Speed command (±8 V/max. speed) 0 6: Servo motor-side droop pulses (±10 V/100 pulses) (Note) 0 7: Servo motor-side droop pulses (±10 V/1000 pulses) (Note) 0 8: Servo motor-side droop pulses (±10 V/10000 pulses) (Note) 0 9: Servo motor-side droop pulses (±10 V/100000 pulses) (Note) 0 A: Feedback position (±10 V/1 Mpulse) (Note) 0 B: Feedback position (±10 V/10 Mpulses) (Note) 0 C: Feedback position (±10 V/100 Mpulses) (Note) 0 D: Bus voltage (200 V class and 100 V class: +8 V/400 V, 400 V class: +8 V/800 V) 0 E: Speed command 2 (±8 V/max. speed) Note. Encoder pulse unit	00h	
			_ x _ _:	For manufacturer setting	0h
			x _ _ _:	For manufacturer setting	0h
PC10	Analog monitor 2 output Used to selection the signal provided to the analog monitor 2 (MO2) output. 0 0 0 x: Select the analog monitor 2 (MO2) output The settings are the same as those of [Pr. PC09].	0001h	PC10	Analog monitor 2 output Select a signal to output to Analog monitor 2 (MO2).	
			__ x x: Analog monitor 2 output selection Refer to [Pr. PC09] for settings.	01h	
			_ x _ _:	For manufacturer setting	0h
			x _ _ _:	For manufacturer setting	0h
PC11	Analog monitor 1 offset Used to set the offset voltage of the analog monitor 1 (MO1) output.	0	PC11	Same as MR-J3 Analog monitor 1 offset This is used to set the offset voltage of Analog monitor 1 (MO1).	0

Part 3: Review on Replacement of MR-J3-_B_ with MR-J4-_B_

MR-J3-_B_			MR-J4-_B_		
No.	Name and function	Initial value	No.	Name and function	Initial value
PC12	Analog monitor 2 offset Used to set the offset voltage of the analog monitor 2 (MO2) output.	0	PC12	Same as MR-J3 Analog monitor 2 offset This is used to set the offset voltage of Analog monitor 2 (MO2).	0
PC13	Analog monitor feedback position output standard data Low Used to set the standard position of feedback output with analog monitor 1 (M01) or 2 (M02). For this parameter, the lower-order four digits of standard position in decimal numbers are set.	0	PC13	Same as MR-J3 Analog monitor - Feedback position output standard data ▪ Low Set a monitor output standard position (lower 4 digits) for the feedback position for when selecting "Feedback position" for Analog monitor 1 (M01) and Analog monitor 2 (M02). Monitor output standard position = [Pr. PC14] setting × 10000 + [Pr. PC13] setting	0
PC14	Analog monitor feedback position output standard data High Used to set the standard position of feedback output with analog monitor 1 (M01) or 2 (M02). For this parameter, the higher-order four digits of standard position in decimal numbers are set.	0	PC14	Same as MR-J3 Analog monitor - Feedback position output standard data ▪ High Set a monitor output standard position (higher 4 digits) for the feedback position for when selecting "Feedback position" for Analog monitor 1 (M01) and Analog monitor 2 (M02). Monitor output standard position = [Pr. PC14] setting × 10000 + [Pr. PC13] setting	0
PC17	Function Selection C-4 This parameter cannot be used in the speed control mode or in the torque control mode. Home position setting condition in the absolute position detection system can be selected. 0 0 0 x: Selection of home position setting condition 0: Need to pass motor Z-phase after the power supply is switched on. 1: Not need to pass motor Z-phase after the power supply is switched on.	0000h	PC17	Same setting as MR-J3 Function selection C-4 This is used to select a home position setting condition. ___ x: Selection of home position setting condition 0: Need to pass servo motor Z-phase after power on 1: Not need to pass servo motor Z-phase after power on __ x _: When the rotary servo motor is used, the setting need not be changed. _ x _ _: For manufacturer setting x _ _ _: For manufacturer setting	0h 0h 0h 0h
PC18	For manufacturer setting Do not change this value by any means.	0000h	PC18	Function selection C-5 This is used to select an occurring condition of [AL. E9 Main circuit off warning]. ___ x: For manufacturer setting __ x _: For manufacturer setting _ x _ _: For manufacturer setting x _ _ _: [AL. E9 Main circuit off warning] selection 0: Detection with ready-on and servo-on command 1: Detection with servo-on command	0h 0h 0h 0h

Part 3: Review on Replacement of MR-J3-__B__ with MR-J4-__B__

MR-J3-__B__			MR-J4-__B__		
No.	Name and function	Initial value	No.	Name and function	Initial value
PC20	<p>Function Selection C-7</p> <p>Set this function if undervoltage alarm occurs because of distorted power supply voltage waveform when using power regenerative converter or power regeneration common converter.</p> <p>0 0 0 x:</p> <p>Setting when undervoltage alarm occurs</p> <p>0: Initial value (Waveform of power supply voltage is not distorted)</p> <p>1: Set "1" if undervoltage alarm occurs because of distorted power supply voltage waveform when using power regenerative converter or power regeneration common converter.</p>	0000h	PC20	Function selection C-7	
				<p>This is used to select an undervoltage alarm detection method.</p> <p>__ _ x:</p> <p>[AL. 10 Undervoltage] detection method selection</p> <p>This is set when FR-RC-(H) or FR-CV-(H) is used and if [AL. 10 undervoltage] occurs due to distorted power supply voltage waveform.</p> <p>0: [AL. 10] not occurrence</p> <p>1: [AL. 10] occurrence</p>	0h
				<p>__ _ x _:</p> <p>For manufacturer setting</p>	0h
				<p>_ x _ _:</p> <p>Undervoltage alarm selection</p> <p>Select the alarm and warning for when the bus voltage drops to the undervoltage alarm level.</p> <p>0: [AL. 10] regardless of servo motor speed</p> <p>1: [AL. E9] at servo motor speed 50 r/min or less, [AL. 10] at over 50 r/min</p>	0h
				x _ _ _:	0h
				For manufacturer setting	
PC21	<p>Alarm history clear</p> <p>Used to clear the alarm history.</p> <p>0 0 0 x:</p> <p>Alarm history clear</p> <p>0: Invalid</p> <p>1: Valid</p> <p>When alarm history clear is made valid, the alarm history is cleared at next power-on.</p> <p>After the alarm history is cleared, the setting is automatically made invalid (reset to 0).</p>	0000h	PC21	Same as MR-J3	
				Alarm history clear	
				Used to clear the alarm history.	
				<p>__ _ x:</p> <p>Alarm history clear selection</p> <p>0: Disabled</p> <p>1: Enabled</p> <p>When "Enabled" is set, the alarm history will be cleared at the next power-on. After the alarm history is cleared, the setting is automatically disabled.</p>	0h
				<p>__ _ x _:</p> <p>For manufacturer setting</p>	0h
				_ x _ _:	0h
				For manufacturer setting	
				x _ _ _:	0h
				For manufacturer setting	

Part 3: Review on Replacement of MR-J3-_B_ with MR-J4-_B_

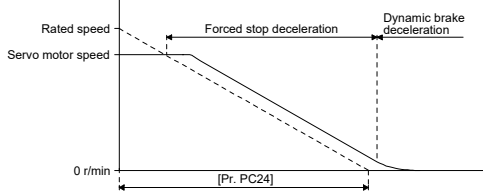
MR-J3-_B_			MR-J4-_B_		
No.	Name and function	Initial value	No.	Name and function	Initial value
PC24	For manufacturer setting Do not change this value by any means.	0000h	PC24	<p>Forced stop deceleration time constant</p> <p>This is used to set deceleration time constant when you use the forced stop deceleration function. Set the time per ms from the rated speed to 0 r/min. Setting "0" will be 100 ms.</p>  <p>[Precautions]</p> <ul style="list-style-type: none"> ▪ If the servo motor torque is saturated at the maximum torque during forced stop deceleration because the set time is too short, the time to stop will be longer than the set time constant. ▪ [AL. 50 Overload alarm 1] or [AL. 51 Overload alarm 2] may occur during forced stop deceleration, depending on the set value. ▪ After an alarm that leads to a forced stop deceleration, if an alarm that does not lead to a forced stop deceleration occurs or if the control circuit power supply is cut, dynamic braking will start regardless of the deceleration time constant setting. ▪ Set a longer time than deceleration time at quick stop of the controller. If a shorter time is set, [AL. 52 Error excessive] may occur. 	100
PC29	For manufacturer setting Do not change this value by any means.	0000h	PC29	<p>Function selection C-B</p> <p>This is used to select the POL reflection at torque control.</p> <p>___x:</p> <p>For manufacturer setting</p> <p>__x_:</p> <p>For manufacturer setting</p> <p>_x__:</p> <p>For manufacturer setting</p> <p>x___:</p> <p>POL reflection selection at torque control</p> <p>0: Enabled</p> <p>1: Disabled</p>	0h
PC31	For manufacturer setting Do not change this value by any means.	0000h	PC31	<p>Vertical axis freefall prevention compensation amount</p> <p>Set the compensation amount of the vertical axis freefall prevention function.</p> <p>Set it per servo motor rotation amount travel distance.</p> <p>When a positive value is set, compensation is performed to the address increasing direction. When a negative value is set, compensation is performed to the address decreasing direction.</p> <p>The vertical axis freefall prevention function is performed when all of the following conditions are met.</p> <ol style="list-style-type: none"> 1) Position control mode 2) The value of the parameter is other than "0". 3) The forced stop deceleration function is enabled. 4) Alarm occurs or EM2 turns off when the servo motor speed is zero speed or less. 5) MBR (Electromagnetic brake interlock) was enabled in [Pr. PD07] to [Pr. PD09], and the base circuit shut-off delay time was set in [Pr. PC02]. 	0

Part 3: Review on Replacement of MR-J3- _B_ with MR-J4- _B_

MR-J3- _B_			MR-J4- _B_															
No.	Name and function	Initial value	No.	Name and function	Initial value													
PD02	For manufacturer setting Do not change this value by any means.	0000h	PD02	Input signal automatic on selection 2														
			___x (HEX)	___x: FLS (Upper stroke limit) selection 0: Disabled 1: Enabled	0h													
			__x_:	RLS (Lower stroke limit) selection 0: Disabled 1: Enabled														
			x:	For manufacturer setting														
			x_:	For manufacturer setting														
			__x_	For manufacturer setting	0h													
			x	For manufacturer setting	0h													
			x_	For manufacturer setting	0h													
			Convert the setting value into hexadecimal as follows.															
			<table border="1" style="margin-left: auto; margin-right: auto;"> <thead> <tr> <th rowspan="2">Signal name</th> <th colspan="2">Initial value</th> </tr> <tr> <th>BIN</th> <th>HEX</th> </tr> </thead> <tbody> <tr> <td>FLS (Upper stroke limit) selection</td> <td>0</td> <td rowspan="4">0</td> </tr> <tr> <td>RLS (Lower stroke limit) selection</td> <td>0</td> </tr> <tr> <td></td> <td>0</td> </tr> <tr> <td></td> <td>0</td> </tr> </tbody> </table> <p style="font-size: small; margin-left: 100px;">BIN 0: Use for an external input signal. BIN 1: Automatic on</p>					Signal name	Initial value		BIN	HEX	FLS (Upper stroke limit) selection	0	0	RLS (Lower stroke limit) selection	0	
Signal name	Initial value																	
	BIN	HEX																
FLS (Upper stroke limit) selection	0	0																
RLS (Lower stroke limit) selection	0																	
	0																	
	0																	

Part 3: Review on Replacement of MR-J3-__B__ with MR-J4-__B__

MR-J3-__B__			MR-J4-__B__		
No.	Name and function	Initial value	No.	Name and function	Initial value
PD07	<p>Output signal device selection 1 (CN3-13) Any input signal can be assigned to the CN3-13 pin. As the initial value, MBR is assigned to the pin.</p> <p>0 0 x x: Select the output device of the CN3-13 pin. 00: Always OFF 01: For manufacturer setting (Note 3) 02: RD 03: ALM 04: INP (Note1, 4) 05: MBR 06: DB 07: TLC (Note 4) 08: WNG 09: BWNG 0A: SA (Note 2) 0B: VLC (Note 5) 0C: ZSP 0D: For manufacturer setting (Note 3) 0E: For manufacturer setting (Note 3) 0F: CDPS 10: For manufacturer setting (Note 3) 11: ABSV (Note 1) 12 to 1F: For manufacturer setting (Note 3) 20 to 3F: For manufacturer setting (Note 3)</p> <p>Note 1. It becomes always OFF in the speed control mode. 2. It becomes always OFF in the position control mode or in the torque control mode. 3. For manufacturer setting Never change this setting. 4. It becomes always OFF in the torque control mode. 5. It becomes always OFF in the position control mode or in the speed control mode.</p>	0005h	PD07	<p>Same setting as MR-J3</p> <p>Output device selection 1 You can assign any output device to the CN3-13 pin.</p>	05h
				<p>__ x x: Device selection 0 0: Always off 0 2: RD (Ready) 0 3: ALM (Malfunction) 0 4: INP (In-position) 0 5: MBR (Electromagnetic brake interlock) 0 6: DB (Dynamic brake interlock) 0 7: TLC (Limiting torque) 0 8: WNG (Warning) 0 9: BWNG (Battery warning) 0 A: SA (Speed reached) 0 C: ZSP (Zero speed detection) 0 F: CDPS (Variable gain selection) 1 1: ABSV (Absolute position undetermined)</p>	
PD08	<p>Output signal device selection 2 (CN3-9) Any input signal can be assigned to the CN3-9 pin. As the initial value, INP is assigned to the pin. The devices that can be assigned and the setting method are the same as in [Pr. PD07].</p> <p>0 0 x x: Select the output device of the CN3-9 pin.</p>	0004h	PD08	<p>Same setting as MR-J3</p> <p>Output device selection 2 You can assign any output device to the CN3-9 pin. INP (In-position) is assigned as the initial value. The devices that can be assigned and the setting method are the same as in [Pr. PD07].</p>	04h
				<p>__ x x: Device selection Refer to [Pr. PD07] for settings.</p>	
				<p>_ x _ _: For manufacturer setting</p>	0h
				<p>x _ _ _: For manufacturer setting</p>	0h

Part 3: Review on Replacement of MR-J3-__B__ with MR-J4-__B__

MR-J3-__B__			MR-J4-__B__		
No.	Name and function	Initial value	No.	Name and function	Initial value
PD09	<p>Output signal device selection 3 (CN3-15) Any input signal can be assigned to the CN3-15 pin. As the initial value, ALM is assigned to the pin. The devices that can be assigned and the setting method are the same as in [Pr. PD07].</p> <p>0 0 x x: Select the output device of the CN3-15 pin.</p>	0003h	PD09	Same setting as MR-J3	
				Output device selection 3 You can assign any output device to the CN3-15 pin. ALM (Malfunction) is assigned as the initial value. The devices that can be assigned and the setting method are the same as in [Pr. PD07].	
				__ x x: Device selection Refer to [Pr. PD07] for settings.	03h
				_ x __ : For manufacturer setting	0h
				x ___ : For manufacturer setting	0h
PD11	<p>For manufacturer setting Do not change this value by any means.</p>	0004h	PD11	Input filter setting Select the input filter.	
				___ x: Input signal filter selection Refer to the servo system controller instruction manual for the setting. If external input signal causes chattering due to noise, etc., input filter is used to suppress it. 0: None 1: 0.888 [ms] 2: 1.777 [ms] 3: 2.666 [ms] 4: 3.555 [ms]	4h
				__ x _ : For manufacturer setting	0h
				_ x __ : For manufacturer setting	0h
				x ___ : For manufacturer setting	0h
PD12	<p>For manufacturer setting Do not change this value by any means.</p>	0000h	PD12	Function selection D-1	
				___ x : For manufacturer setting	0h
				__ x _ : For manufacturer setting	0h
				_ x __ : For manufacturer setting	0h
				x ___ : Servo motor thermistor enabled/disabled selection 0: Enabled 1: Disabled For servo motors without thermistor, the setting will be disabled. This parameter setting is used with servo amplifier with software version A5 or later.	0h

Part 3: Review on Replacement of MR-J3- _B_ with MR-J4- _B_

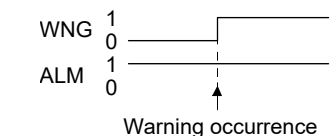
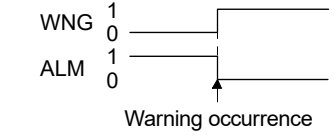
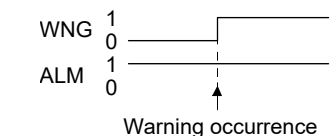
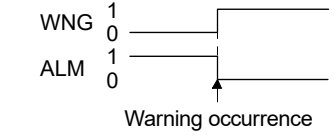
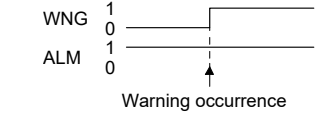
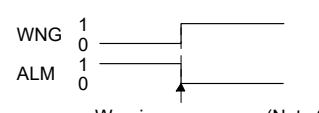
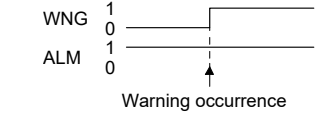
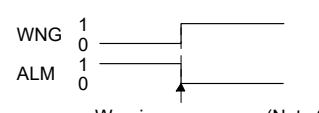
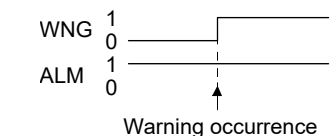
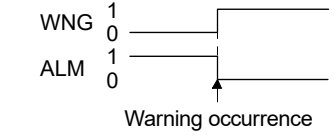
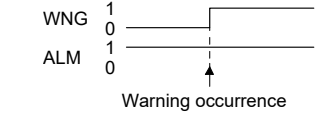
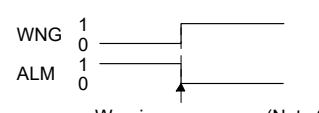
MR-J3- _B_			MR-J4- _B_														
No.	Name and function	Initial value	No.	Name and function	Initial value												
PD13	For manufacturer setting Do not change this value by any means.	0000h	PD13	Function selection D-2 Select the INP (In-position) on condition. This parameter is supported with software version B4 or later. ___x: For manufacturer setting __x_: For manufacturer setting _x__: INP (In-position) on condition selection Select a condition that INP (In-position) is turned on. 0: Droop pulses are within the in-position range. 1: The command pulse frequency is 0, and droop pulses are within the in-position range. When the position command is not inputted for about 1 ms, the command pulse frequency is decided as 0. x___: For manufacturer setting	0h 0h 0h 0h												
PD14	Function selection D-3 Set the ALM output signal at warning occurrence. 0 0 x 0: Selection of output device at warning occurrence Select the warning (WNG) and trouble (ALM) output status at warning occurrence. Output of Servo amplifier <table border="1" data-bbox="236 1086 710 1429"> <thead> <tr> <th>Setting</th> <th>Device status (Note)</th> </tr> </thead> <tbody> <tr> <td>0</td> <td>  </td> </tr> <tr> <td>1</td> <td>  </td> </tr> </tbody> </table> <p>Note. 0: off 1: on</p>	Setting	Device status (Note)	0		1		0000h	PD14	Same setting as MR-J3 Function selection D-3 ___x: For manufacturer setting __x_: Selection of output device at warning occurrence Select WNG (Warning) and ALM (Malfunction) output status at warning occurrence. Servo amplifier output <table border="1" data-bbox="880 1131 1355 1478"> <thead> <tr> <th>Setting</th> <th>Device status (Note1)</th> </tr> </thead> <tbody> <tr> <td>0</td> <td>  </td> </tr> <tr> <td>1</td> <td>  </td> </tr> </tbody> </table> <p>Note1. 0: Off 1: On 2. Although ALM is turned off upon occurrence of the warning, the forced stop deceleration is performed.</p> _x___: For manufacturer setting x___: For manufacturer setting	Setting	Device status (Note1)	0		1		0000h
Setting	Device status (Note)																
0																	
1																	
Setting	Device status (Note1)																
0																	
1																	

Part 3: Review on Replacement of MR-J3- _B_ with MR-J4- _B_

MR-J3- _B_			MR-J4- _B_												
No.	Name and function	Initial value	No.	Name and function	Initial value										
PD15	<p>Driver communication setting</p> <p>This parameter setting is used with servo amplifier with software version C1 or later. Check the software version using Setup software (SETUP221E).</p> <p>This parameter is used to select master/slave axis for the driver communication.</p>	0000h	PD15	<p>Same setting as MR-J3</p> <p>Driver communication setting</p> <p>This parameter is used to select master/slave axis for the driver communication.</p> <p>This is available only when the forced stop deceleration function is disabled. When the forced stop deceleration function is enabled, [AL. 37 Parameter error] will occur.</p> <p>This parameter setting is used with servo amplifier with software version A8 or later.</p>											
	<p>0 0 _ x:</p> <p>Master axis operation selection</p> <p>0: Disabled (not using master-slave operation function)</p> <p>1: Enabled (this servo amplifier: master axis)</p>			<p>___ x:</p> <p>Master axis operation selection</p> <p>Setting "1" other than in standard control mode will trigger [AL. 37].</p> <p>0: Disabled (not using master-slave operation function)</p> <p>1: Enabled (this servo amplifier: master axis)</p>		0h									
	<p>0 0 x _:</p> <p>Slave axis operation selection</p> <p>0: Disabled (not using master-slave operation function)</p> <p>1: Enabled (this servo amplifier: slave axis)</p> <table border="1" data-bbox="247 884 694 1019"> <thead> <tr> <th colspan="2">Master-slave operation function</th> <th>Setting value</th> </tr> </thead> <tbody> <tr> <td>Not used</td> <td></td> <td>0000</td> </tr> <tr> <td rowspan="2">Used</td> <td>Master</td> <td>0001</td> </tr> <tr> <td>Slave</td> <td>0010</td> </tr> </tbody> </table>			Master-slave operation function		Setting value	Not used		0000	Used	Master	0001	Slave	0010	<p>__ x _:</p> <p>Slave axis operation selection</p> <p>Setting "1" other than in standard control mode will trigger [AL. 37].</p> <p>0: Disabled (not using master-slave operation function)</p> <p>1: Enabled (this servo amplifier: slave axis)</p>
Master-slave operation function		Setting value													
Not used		0000													
Used	Master	0001													
	Slave	0010													
			<p>_ x _ _:</p> <p>For manufacturer setting</p>	0h											
			<p>x _ _ _:</p> <p>For manufacturer setting</p> <table border="1" data-bbox="885 1064 1348 1198"> <thead> <tr> <th colspan="2">Master-slave operation function</th> <th>Setting value</th> </tr> </thead> <tbody> <tr> <td>Not used</td> <td></td> <td>0000</td> </tr> <tr> <td rowspan="2">Used</td> <td>Master</td> <td>0001</td> </tr> <tr> <td>Slave</td> <td>0010</td> </tr> </tbody> </table>	Master-slave operation function		Setting value	Not used		0000	Used	Master	0001	Slave	0010	0h
Master-slave operation function		Setting value													
Not used		0000													
Used	Master	0001													
	Slave	0010													
PD16	<p>Driver communication setting - Master - Transmit data selection 1</p> <p>This parameter setting is used with servo amplifier with software version C1 or later. Check the software version using Setup software (SETUP221E).</p> <p>This parameter is used to select transmit data from master axis to slave axis.</p> <p>When setting this amplifier as master axis ([Pr. PD15] = "0001"), select "0038 (torque command)" with this parameter.</p>	0000h	PD16	<p>Same setting as MR-J3</p> <p>Driver communication setting - Master - Transmit data selection 1</p> <p>This parameter is used to select transmit data from master axis to slave axis.</p> <p>When setting this amplifier as master axis ([Pr. PD15] is "___ 0 1"), select "___ 3 8 (torque command)" with this parameter.</p> <p>This parameter setting is used with servo amplifier with software version A8 or later.</p>											
	<p>0 0 x x:</p> <p>Transmission data selection</p> <p>00: Disabled</p> <p>38: Torque command</p>			<p>__ x x:</p> <p>Transmission data selection</p> <p>00: Disabled</p> <p>38: Torque command</p>		00h									
				<p>_ x _ _:</p> <p>For manufacturer setting</p>		0h									
				<p>x _ _ _:</p> <p>For manufacturer setting</p>		0h									

Part 3: Review on Replacement of MR-J3-__B__ with MR-J4-__B__

MR-J3-__B__			MR-J4-__B__		
No.	Name and function	Initial value	No.	Name and function	Initial value
PD17	<p>Driver communication setting - Master - Transmit data selection 2</p> <p>This parameter setting is used with servo amplifier with software version C1 or later. Check the software version using Setup software (SETUP221E).</p> <p>This parameter is used to select transmit data from master axis to slave axis.</p> <p>When setting this amplifier as master axis ([Pr. PD15] = "0001"), select "003A (speed limit command)" with this parameter.</p> <p>0 0 x x: Transmission data selection 00: Disabled 3A: speed limit command</p>	0000h	PD17	<p>Driver communication setting - Master - Transmit data selection 2</p> <p>This parameter is used to select transmit data from master axis to slave axis.</p> <p>When setting this amplifier as master axis ([Pr. PD15] is "__ 0 1"), select "__ 3 A (speed limit command)" with this parameter.</p> <p>This parameter setting is used with servo amplifier with software version A8 or later.</p>	
				<p>__ x x: Transmission data selection 00: Disabled 3A: speed limit command</p>	00h
				<p>_ x __ : For manufacturer setting</p>	0h
				<p>x __ __ : For manufacturer setting</p>	0h
PD20	<p>Driver communication setting - Slave - Master axis No. selection 1</p> <p>This parameter setting is used with servo amplifier with software version C1 or later. Check the software version using Setup software (SETUP221E).</p> <p>Select a master axis when this amplifier is slave axis.</p> <p>When setting this amplifier as slave axis ([Pr. PD15] = "0010"), set the axis No. of the servo amplifier of master. Refer to "MR-J3-__B__ Servo Amplifier Instruction Manual" for details of axis Nos.</p>	0	PD20	<p>Driver communication setting - Slave - Master axis No. selection 1</p> <p>Select a master axis when this amplifier is slave axis.</p> <p>When setting this amplifier as slave axis ([Pr. PD15] is "__ 1 0"), set the axis No. of the servo amplifier of master. Setting "0" disables this parameter.</p> <p>This parameter setting is used with servo amplifier with software version A8 or later.</p>	0
PD30	<p>Master-slave operation - Torque command coefficient on slave</p> <p>This parameter setting is used with servo amplifier with software version C1 or later. Check the software version using Setup software (SETUP221E).</p> <p>This parameter is used to set an internal torque command coefficient to torque command value received from master axis.</p> <p>This parameter is enabled when this amplifier is set as slave axis ([Pr. PD15] = "0010"). Convert a decimal value to a hexadecimal value for input. The maximum value is 500. Setting over 500 will be 500.</p> <p>Setting 100 [%] (0064h in hexadecimal) means multiplication of one. The torque ratio will be 100 (master) to 100 (slave). Setting 90 [%] (005Ah in hexadecimal) means multiplication of 0.9. The torque ratio will be 100 (master) to 90 (slave).</p>	0000h	PD30	<p>Master-slave operation - Torque command coefficient on slave</p> <p>This parameter is used to set an internal torque command coefficient to torque command value received from master axis.</p> <p>This parameter is enabled when this amplifier is set as slave axis ([Pr. PD15] is "__ 1 0"). The maximum value is 500. Setting over 500 will be 500.</p> <p>Setting 100 [%] means multiplication of one. The torque ratio will be 100 (master) to 100 (slave).</p> <p>Setting 90 [%] means multiplication of 0.9. The torque ratio will be 100 (master) to 90 (slave).</p> <p>This parameter setting is used with servo amplifier with software version A8 or later.</p>	0

Part 3: Review on Replacement of MR-J3-_B_ with MR-J4-_B_

MR-J3-_B_			MR-J4-_B_		
No.	Name and function	Initial value	No.	Name and function	Initial value
PD31	<p>Master-slave operation - Speed limit coefficient on slave</p> <p>This parameter setting is used with servo amplifier with software version C1 or later. Check the software version using Setup software (SETUP221E).</p> <p>This parameter is used to set an internal speed limit value coefficient to speed limit command value received from master axis. This parameter is enabled when this amplifier is set as slave axis ([Pr. PD15] = "0010"). Convert a decimal value to a hexadecimal value for input. The maximum value is 500. Setting over 500 will be 500.</p> <p>Setting 100 [%] (0064h in hexadecimal) means multiplication of one.</p> <p>Setting example: [Pr. PD31 (VLC)] = 0078h (120%), [Pr. PD32 (VLL)] = 012Ch (300 r/min), and master side acceleration/deceleration at 1000 [r/min]</p>	0000h	PD31	<p>Master-slave operation - Speed limit coefficient on slave</p> <p>This parameter is used to set an internal speed limit value coefficient to speed limit command value received from master axis.</p> <p>This parameter is enabled when this amplifier is set as slave axis ([Pr. PD15] is "_ _ 1 0"). The maximum value is 500. Setting over 500 will be 500.</p> <p>Setting 100 [%] means multiplication of one.</p> <p>Setting example: [Pr. PD31 (VLC)] = 140 [%], [Pr. PD32 (VLL)] = 300 [r/min], and master side acceleration/deceleration at 1000 [r/min]</p> <p>This parameter setting is used with servo amplifier with software version A8 or later.</p>	0
PD32	<p>Master-slave operation - Speed limit adjusted value on slave</p> <p>This parameter setting is used with servo amplifier with software version C1 or later. Check the software version using Setup software (SETUP221E).</p> <p>This parameter is used to set a minimum value for internal speed limit value.</p> <p>This parameter is enabled when this amplifier is set as slave axis ([Pr. PD15] = "0010"). Convert a decimal value to a hexadecimal value for input. The speed limit value will not be this setting value or lower.</p> <p>This parameter ensures torque control range at low speed driving (avoid area likely to reach speed limit). Set 100 to 500 [r/min] normally as a reference. Refer to [Pr. PD31] for the setting example.</p>	0000h	PD32	<p>Master-slave operation - Speed limit adjusted value on slave</p> <p>This parameter is used to set a minimum value for internal speed limit value.</p> <p>This parameter is enabled when this amplifier is set as slave axis ([Pr. PD15] is "_ _ 1 0"). The speed limit value will not be this setting value or lower.</p> <p>This parameter ensures torque control range at low speed driving (avoid area likely to reach speed limit). Set 100 to 500 [r/min] normally as a reference. Refer to [Pr. PD31] for the setting example.</p> <p>This parameter setting is used with servo amplifier with software version A8 or later.</p>	0

4. APPLICATION OF FUNCTIONS

POINT
<ul style="list-style-type: none"> ● Refer to "Part 8 Common Reference Material" for the application of functions. <ul style="list-style-type: none"> ▪ J3 compatibility mode <ul style="list-style-type: none"> MR-J4-_B_(-RJ) servo amplifiers have two operation mode: "J4 mode" is for using all functions with full performance and "J3 compatibility mode" for using the conventional MR-J3-_B_ servo amplifiers.

Part 4
Review on Replacement of
MR-J3W-__B with MR-J4W2-__B

Part 4: Replacement of MR-J3W-_B with MR-J4W2-_B

Part 4: Replacement of MR-J3W-_B with MR-J4W2-_B

1. SUMMARY

This section describes the changes to be made when a system using MR-J3W-_B is replaced with a system using MR-J4W2-_B.

2. CASE STUDY ON REPLACEMENT OF MR-J3W-_B

2.1 Review on Replacement Method

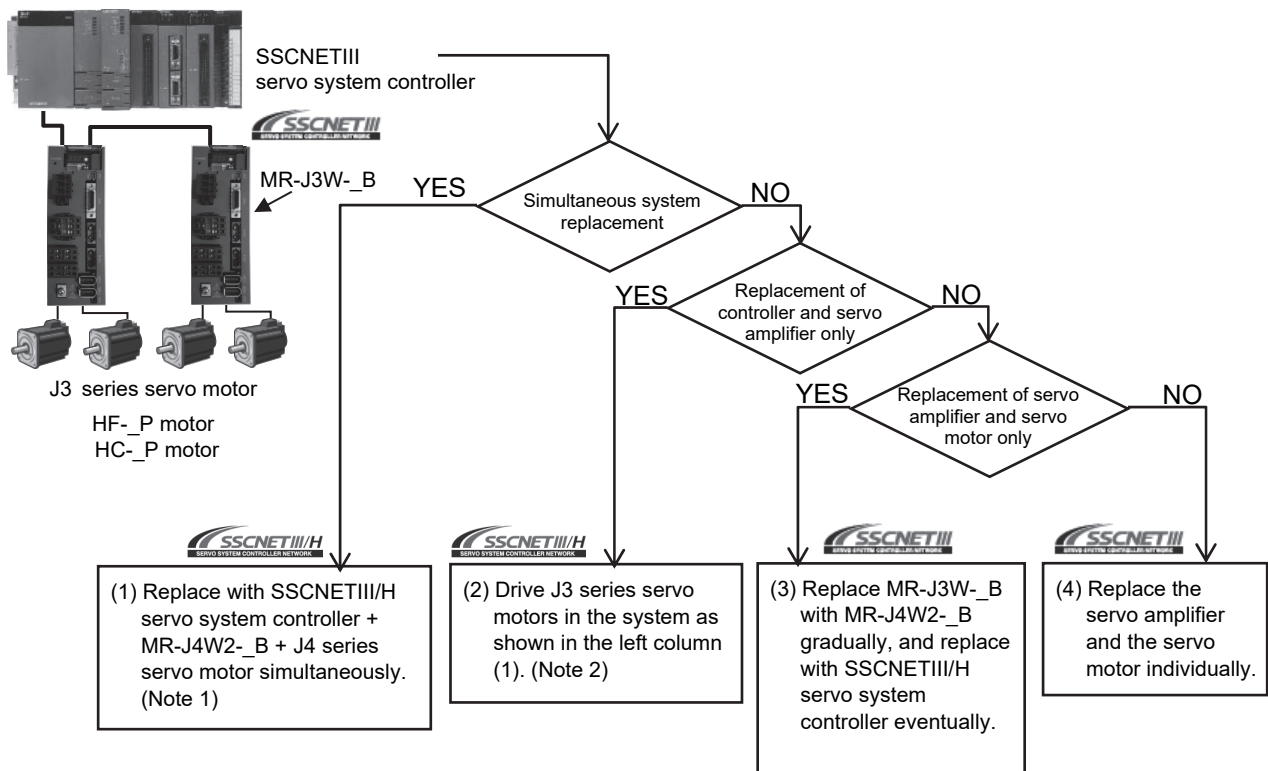

- Note 1. Although heavier burdens including a longer construction period need to be borne, once replaced the system can be operated for a long period of time.
 Note 2. Replacing the system, you can drive some J3 series servo motors with MR-J4W2-_B (J4 mode) and MR-J4W2-_B (J3 compatibility mode). Refer to "Part 8 Common Reference Material" for the applicable servo motor.

2.2 Servo Amplifier Replacement Model

The following shows the target models (MR-J3W series) and replacement models (MR-J4W2-_B servo amplifier).

Servo amplifier model
MR-J3W-22B
MR-J3W-44B
MR-J3W-77B
MR-J3W-1010B
MR-J3W-0303BN6

→

Servo amplifier model
MR-J4W2-22B
MR-J4W2-44B
MR-J4W2-77B
MR-J4W2-1010B
MR-J4W2-0303B6

Part 4: Replacement of MR-J3W-_B with MR-J4W2-_B

2.3 Replacement Method

This section shows replacements using a QDS motion controller and an SSCNETIII/H stand-alone motion controller as examples.

(1) For simultaneous replacement

SSCNET III/H servo system controller (Note1) + MR-J4W2-_B + J4 series servo motor

QnUD(E)(H)CPU + SSCNET III/H servo system controller + Q3_DB

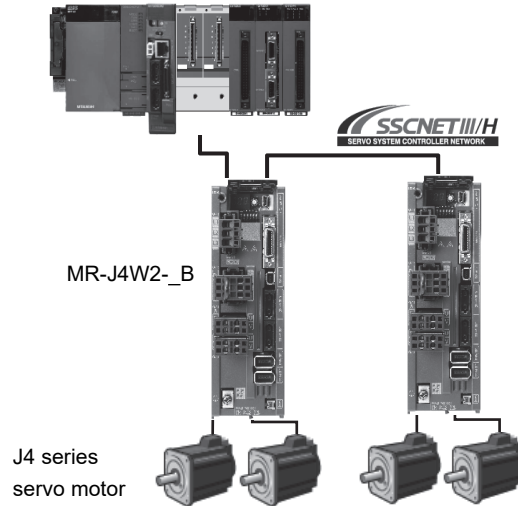

High-speed motion control and excellent extensibility can reduce cycle time

(2) For replacement of controller and amplifier only

SSCNET III/H servo system controller (Note1) + MR-J4W2-_B

QnUD(E)(H)CPU + SSCNET III/H servo system controller + Q3_DB

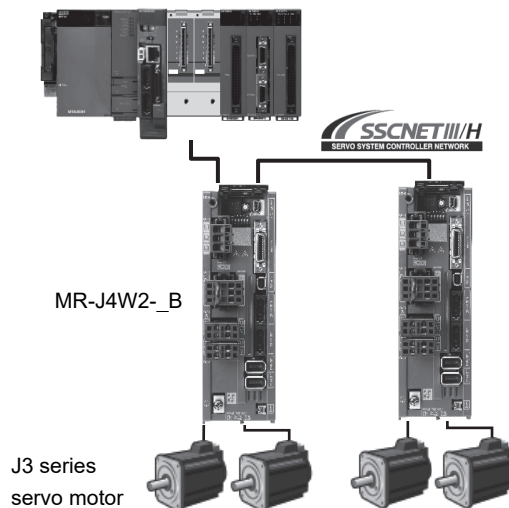

- Note 1. The SSCNETIII/H servo system controller indicates QDS Motion (Q172DSCPU/Q173DSCPU) or Q simple Motion (QD77MS2/4/16).
2. Replacing the system, you can drive some J3 series servo motors with MR-J4W2-_B (J4 mode) and MR-J4W2-_B (J3 compatibility mode). Refer to "Part 8 Common Reference Material" for the applicable servo motor.

Part 4: Replacement of MR-J3W-_B with MR-J4W2-_B

(3) Gradual replacement of MR-J3W-_B with MR-J4W2-_B

POINT													
<ul style="list-style-type: none"> ● MR-J3W-_B cannot drive an HG motor. When the servo motor is replaced with an HG motor, simultaneous replacement with MR-J4W2-_B and HG motor is necessary. ● Replacing the system, you can drive some J3 series servo motors with MR-J4W2-_B (J4 mode) and MR-J4W2-_B (J3 compatibility mode). Refer to "Part 8 Common Reference Material" for the applicable servo motor. ● When an "HC-_P motor" shown below is used, "simultaneous replacement with MR-J4W2-_B and an HG motor" is recommended. When an HG motor is adopted, the capacity of the servo amplifier needs to be changed. (Consider replacement, referring to "torque characteristics" described in "Part 9: Replacement of Motor".) ● The low inertia "HG-JR motor" is recommended for the replacement of "HC-LP motor". To use a servo motor other than the motors listed in following table, check the compatibility with the equipment because the motor inertia, etc. is different. 													
<table border="1"> <thead> <tr> <th colspan="2">Existing device models</th> <th colspan="2">Replacement models for simultaneous replacement (example)</th> </tr> <tr> <th>Servo motor</th> <th>Servo amplifier</th> <th>Servo motor</th> <th>Servo amplifier</th> </tr> </thead> <tbody> <tr> <td>HC-LP102(B)</td> <td>MR-J3W-1010B</td> <td>HG-JR153(B)</td> <td>Replace with the MR-J4-200B.</td> </tr> </tbody> </table>		Existing device models		Replacement models for simultaneous replacement (example)		Servo motor	Servo amplifier	Servo motor	Servo amplifier	HC-LP102(B)	MR-J3W-1010B	HG-JR153(B)	Replace with the MR-J4-200B.
Existing device models		Replacement models for simultaneous replacement (example)											
Servo motor	Servo amplifier	Servo motor	Servo amplifier										
HC-LP102(B)	MR-J3W-1010B	HG-JR153(B)	Replace with the MR-J4-200B.										

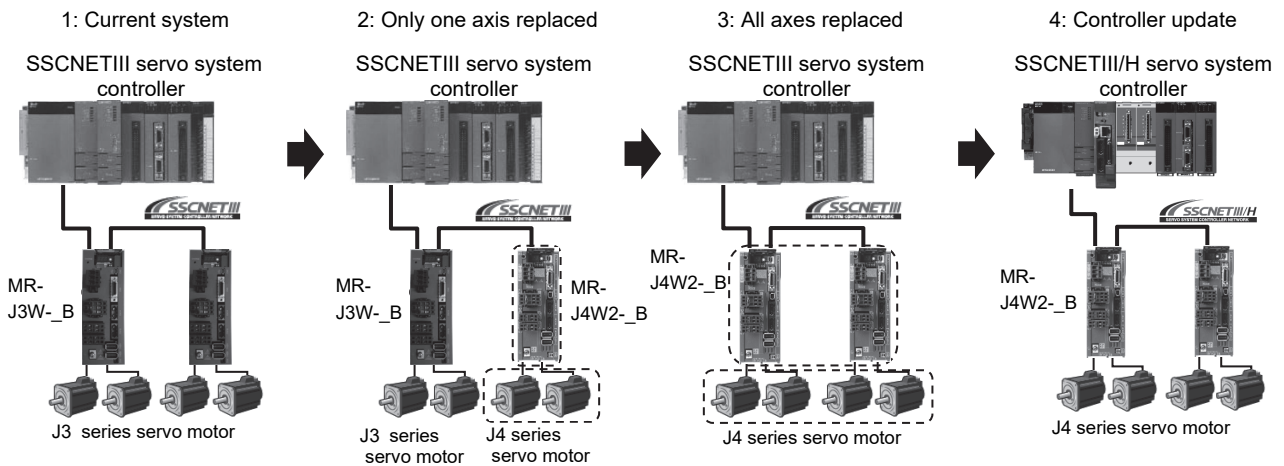

- The MR-J4W2-_B series has the J3 compatibility mode (Note 1). The MR-J4W2-_B series and the MR-J3W-_B series can be used together.
- Optical fiber cables for the conventional SSCNETIII can be used as they are.

- Change the settings of the MR-J4W2-_B to J4 mode using the application software "MR-J4(W)-B mode selection" (Note 2). The servo amplifiers and servo motors can be used as they are.

Note 1. Replacing the system, you can drive some J3 series servo motors with MR-J4W2-_B (J4 mode) and MR-J4W2-_B (J3 compatibility mode). Refer to "Part 8 Common Reference Material" for the applicable servo motor.

Note 2. The application software is available with MR Configurator2 version 1.12N or later.

Part 4: Replacement of MR-J3W-_B with MR-J4W2-_B

(4) Separate repair

(a) Replacement of servo amplifier

Replacing the system, you can drive some J3 series servo motors with MR-J4W2-_B (J4 mode) and MR-J4W2-_B(J3 compatibility mode). Refer to "Part 8 Common Reference Material" for the applicable servo motor.

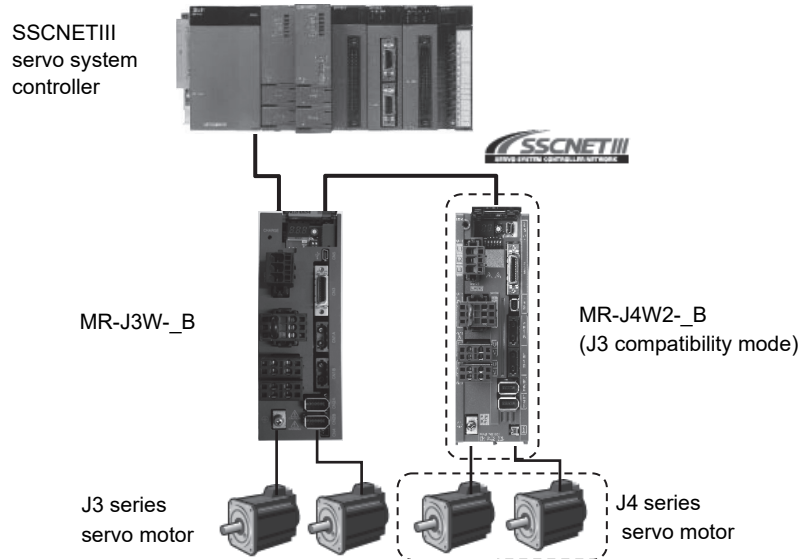

(b) Replacement of servo motor

The J4 series servo motors cannot be driven by MR-J3W-_B. Replace the existing servo amplifiers and servo motors with MR-J4W2-_B servo amplifiers (J3 compatibility mode) and J4 series servo motors simultaneously.

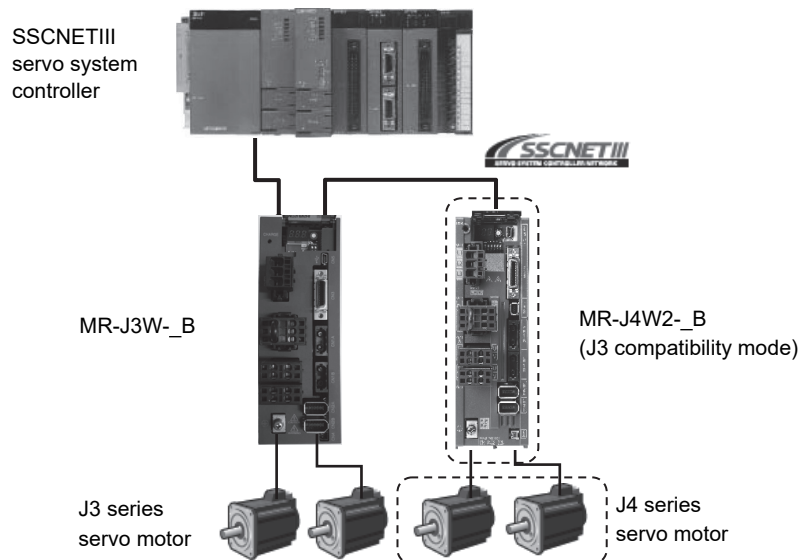

Part 4: Replacement of MR-J3W-_B with MR-J4W2-_B

3. DIFFERENCES BETWEEN MR-J3W-_B AND MR-J4W2-_B

3.1 Function Comparison Table

POINT
● Functions with difference are shown with shading.

(1) MR-J3W-_B/MR-J4W2-_B 200 V class

Item		MR-J3W-_B series		MR-J4W2-_B servo amplifier	
1	Capacity range	MR-J3W-22B	200 W (A axis)/200 W (B axis)	MR-J4W2-22B	200 W (A axis)/200 W (B axis)
		MR-J3W-44B	400 W (A axis)/400 W (B axis)	MR-J4W2-44B	400 W (A axis)/400 W (B axis)
		MR-J3W-77B	750 W (A axis)/750 W (B axis)	MR-J4W2-77B	750 W (A axis)/750 W (B axis)
		MR-J3W-1010B	1 kW (A axis)/1 kW (B axis)	MR-J4W2-1010B	1 kW (A axis)/1 kW (B axis)
2	Internal regenerative resistor	Built-in MR-J3W-22B/-44B 10 W MR-J3W-77B/-1010B 100 W		Built-in MR-J4W2-22B/-44B 20 W MR-J4W2-77B/-1010B 100 W	
3	Dynamic brake	Built-in		Built-in Coasting distance may differ. (Note)	
4	Control circuit power	1-phase AC 200 to 230 V		1-phase AC 200 to 240 V	
5	Main circuit power	1-phase AC 200 to 230 V (MR-J3W-22B/MR-J3W-44B only) 3-phase AC 200 to 230 V		1-phase AC 200 to 240 V (MR-J4W2-22B/MR-J4W2-44B/ MR-J4W2-77B only) 3-phase AC 200 to 240 V	
6	Interface power supply	External supply required (24 V DC)		External supply required (24 V DC)	
7	Auto Tuning	Real-time auto tuning: 32 steps Advanced gain search		Real-time auto tuning: 40 steps One-touch tuning	
8	Control mode	SSCNET III interface (50 Mbps) ▪ Position control mode ▪ Speed control mode		SSCNET III/H interface (150 Mbps) ▪ Position control mode ▪ Speed control mode ▪ Torque control mode	
				< J3 compatibility mode > SSCNET III interface (50 Mbps) ▪ Position control mode ▪ Speed control mode	
9	The number of DIO points (excluding EM1)	DI: 6 points, DO: 4 points		DI: 6 points, DO: 4 points	
10	Encoder pulse output	A/B-phase pulse (differential line driver) × 2 axes		A/B-phase pulse (differential line driver) × 2 axes	
11	DIO interface	input/output: sink/source		input/output: sink/source	
12	Analog input/output	10-bit or equivalent × 2ch		Analog monitors (MO1 and MO2) are not supported. When using MO1 and MO2, please consider replacing the servo amplifier with two MR-J4 single-axis servo amplifiers.	
13	Parameter setting method	Setup software (SETUP221E) MR Configurator2		MR Configurator2	
14	Setup software communication function	USB		USB	
15	Servo motor (Encoder resolution)	HF-_P series (18-bit ABS) HA-_P series (18-bit ABS)		HG series (22 -bit ABS)	
16	Motor maximum torque	HF-KP 350%		HG-KR 350%	
		HF-MP 300%		HG-MR 300%	
		HF-SP 300%		HG-SR 300%	
		HC-UP 300%		HG-UR 300%	
		HF-JP 300% (When HF-JP53 and MR-J3W-1010B are used together: 400%)		HG-JR 300% (When HG-JR53 and MR-J4W2-1010B are used together: 400%)	
		HC-LP 300%			
17	LED display	7-segment 3-digit		7-segment 3-digit	

Part 4: Replacement of MR-J3W-_B with MR-J4W2-_B

Item		MR-J3W-_B series	MR-J4W2-_B servo amplifier
18	Advanced vibration suppression control	Provided	Provided (Advanced vibration suppression control II)
19	Adaptive filter II	Provided	Provided
20	Notch filter	Provided (2 pcs)	Provided (5 pcs)
21	Tough drive	Unprovided	Provided
22	Drive recorder	Unprovided	Provided
23	Forced stop	EM1 (DB stop)	EM1 (DB stop)/ EM2 (deceleration to a stop)

Note. For the coasting distance, refer to "1.2.3 Dynamic brake: coasting distance" in "Part 8 Common Reference Material".

(2) MR-J3W-0303BN6/MR-J4W2-0303B6 48 V DC class /24 V DC class

Item		MR-J3W-0303BN6 servo amplifier	MR-J4W2-0303B6 servo amplifier
1	Capacity range	30 W (A-axis)/30 W (B-axis)	30 W (A-axis)/30 W (B-axis)
2	Internal regenerative resistor	Built-in 1.3 W	Built-in 1.3 W
3	Dynamic brake	Built-in (Electronic type)	Built-in (Electronic type) Coasting distance may differ. (Note)
4	Control circuit power	24 V DC	24 V DC
5	Main circuit power	48 V DC/24 V DC	48 V DC/24 V DC
6	Interface power supply	External supply required (24 V DC)	External supply required (24 V DC)
7	Auto Tuning	Real-time auto tuning: 32 steps Advanced gain search	Real-time auto tuning: 40 steps One-touch tuning
8	Control mode	SSCNET III interface (50 Mbps) <ul style="list-style-type: none"> Position control mode Speed control mode 	SSCNET III/H interface (150 Mbps) <ul style="list-style-type: none"> Position control mode Speed control mode Torque control mode
			< J3 compatibility mode > SSCNET III interface (50 Mbps) <ul style="list-style-type: none"> Position control mode Speed control mode
9	The number of DIO points (excluding EM1)	DI: 6 points, DO: 4 points	DI: 6 points, DO: 4 points
10	Encoder pulse output	A/B-phase pulse (differential line driver) × 2 axes	A/B-phase pulse (differential line driver) × 2 axes
11	DIO interface	input/output: sink/source	input/output: sink/source
12	Analog monitor output	10-bit or equivalent × 2ch	10-bit or equivalent × 2ch
13	Parameter setting method	Setup software (SETUP221E) MR Configurator2	MR Configurator2
14	Setup software communication function	USB	USB
15	Servo motor (Encoder resolution)	HG-AK series (18-bit ABS)	HG-AK series (18-bit ABS)
16	LED display	7-segment 3-digit	7-segment 3-digit
17	Advanced vibration suppression control	Provided	Provided (Advanced vibration suppression control II)
18	Adaptive filter II	Provided	Provided
19	Notch filter	Provided (2 pcs)	Provided (5 pcs)
20	Tough drive	Unprovided	Provided (The instantaneous power failure tough drive is unavailable.)
21	Drive recorder	Unprovided	Provided
22	Forced stop	EM1 (DB stop)	EM1 (DB stop)/ EM2 (deceleration to a stop)
23	DIN rail mounting	unattachable	attachable

Note. For the coasting distance, refer to "1.2.3 Dynamic brake: coasting distance" in "Part 8: Common Reference Material".

Part 4: Replacement of MR-J3W-_B with MR-J4W2-_B

3.2 Configuration including auxiliary equipment

(1) MR-J3W-_B

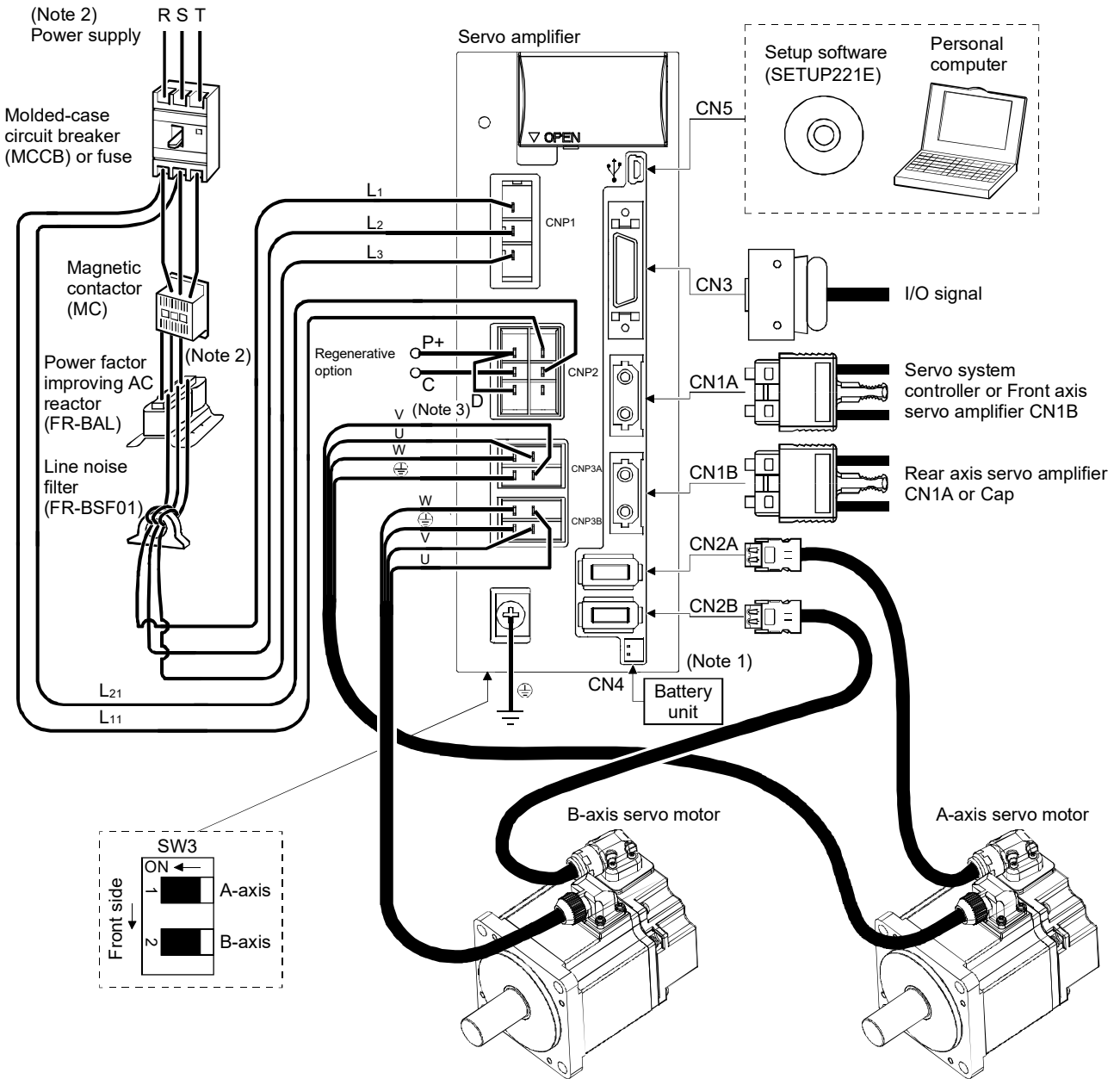

- Note 1. A battery unit consists of one MR-BTCASE battery case and eight MR-BAT batteries. Use the battery unit in the absolute position detection system of the position control mode.
- Note 2. For 1-phase 200 V to 230 V AC, connect the power supply to L₁/L₂ and leave L₃ open. Refer to section 3.1 for the power supply specification.
- Note 3. Make sure to connect the P+ terminal to the D terminal. When using the regenerative option, Refer to "MR-J3W-0303BN6/MR-J3W-_B Servo Amplifier Instruction Manual".

Part 4: Replacement of MR-J3W-_B with MR-J4W2-_B

(2) MR-J4W2-_B

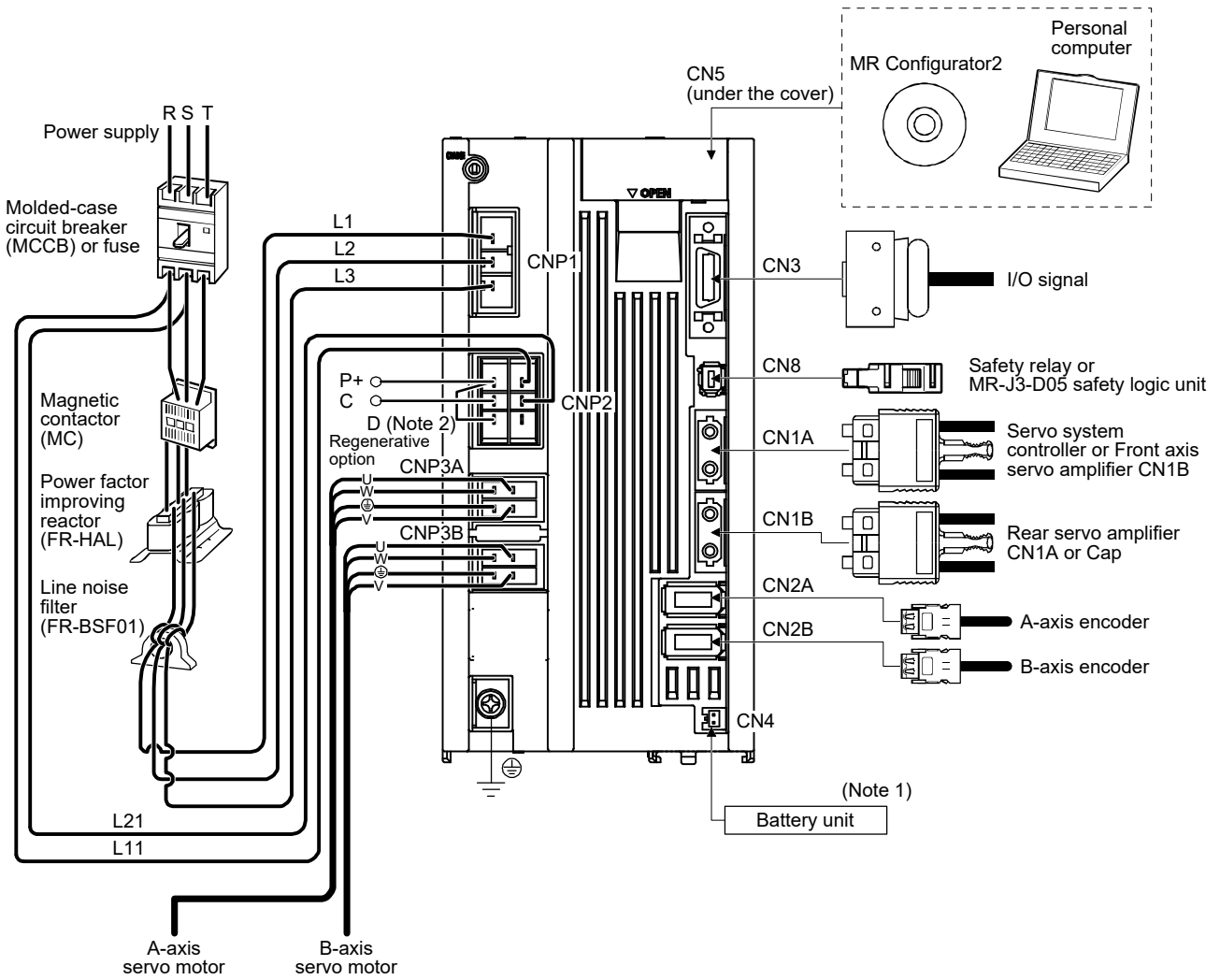

- Note 1. The battery unit consists of an MR-BT6VCASE battery case and five MR-BAT6V1 batteries. The battery unit is used in the absolute position detection system. For details, refer to "MR-J4W2-_B/MR-J4W3-_B/MR-J4W2-0303B6 Servo Amplifier Instruction Manual".
- Note 2. Always connect P+ and D. When using the regenerative option, Refer to, "MR-J4W2-_B/MR-J4W3-_B/MR-J4W2-0303B6 Servo Amplifier Instruction Manual".

Part 4: Replacement of MR-J3W-_B with MR-J4W2-_B

(3) MR-J3W-0303BN6

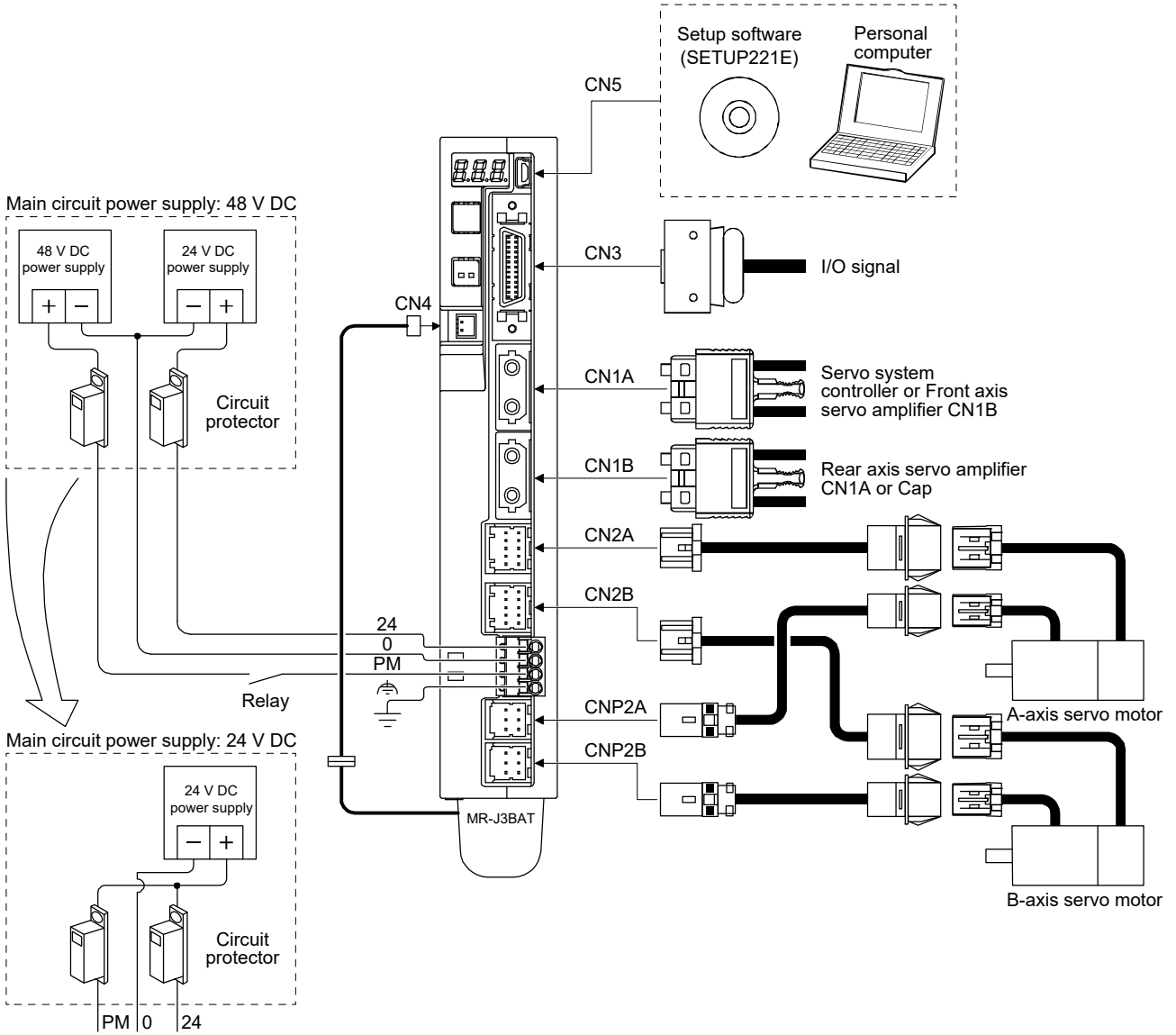

Part 4: Replacement of MR-J3W-_B with MR-J4W2-_B

(4) MR-J4W2-0303B6

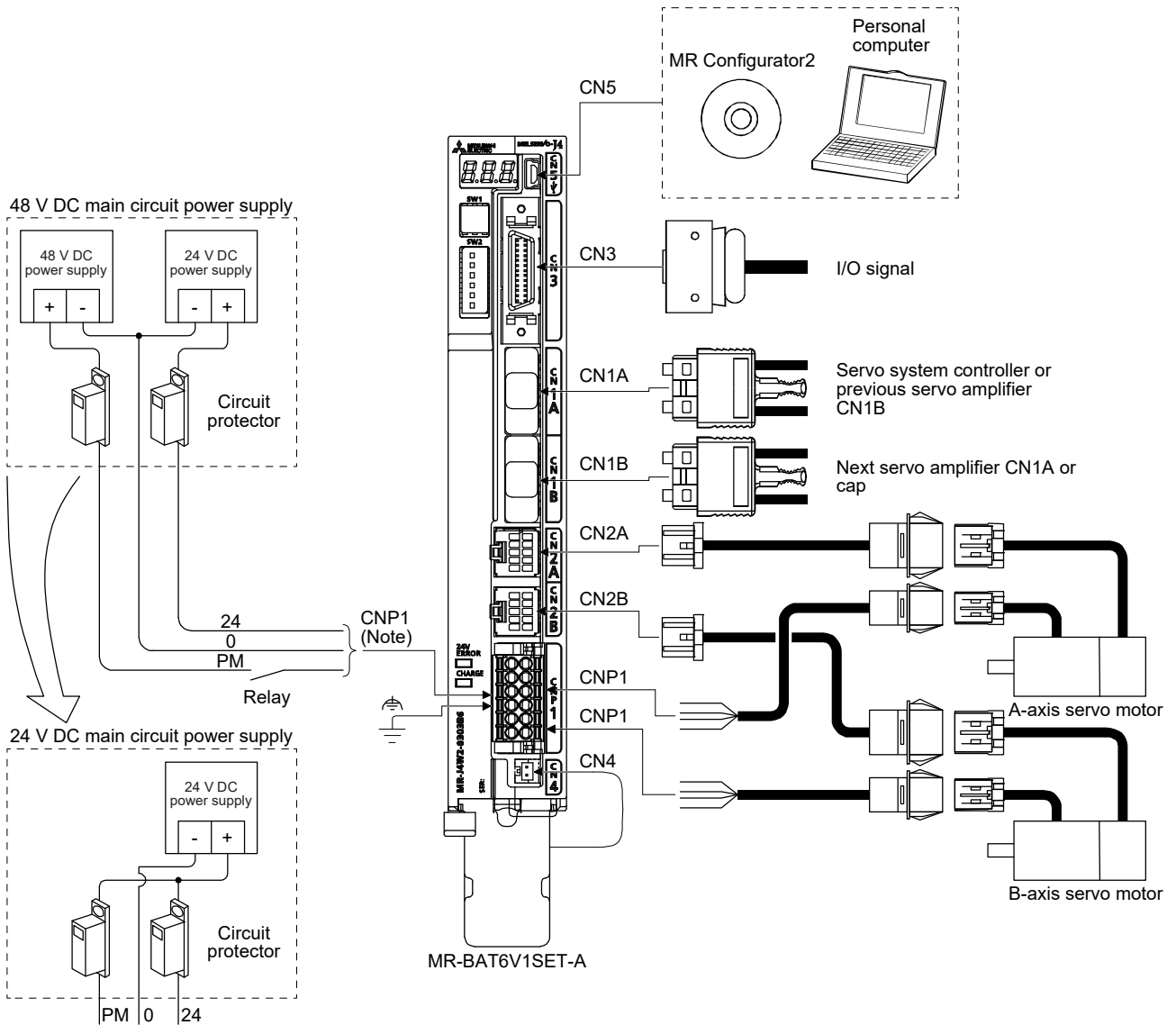

Note. For details, refer to "MR-J4W2-_B/MR-J4W3-_B/MR-J4W2-0303B6 Servo Amplifier Instruction Manual".

Part 4: Replacement of MR-J3W-_B with MR-J4W2-_B

3.3 Comparison of Networks

POINT
● Refer to "Part 8: Common Reference Material".

3.4 Comparison of Standard Connection Diagrams

(1) MR-J3W-_B/MR-J4W2-_B 200 V class

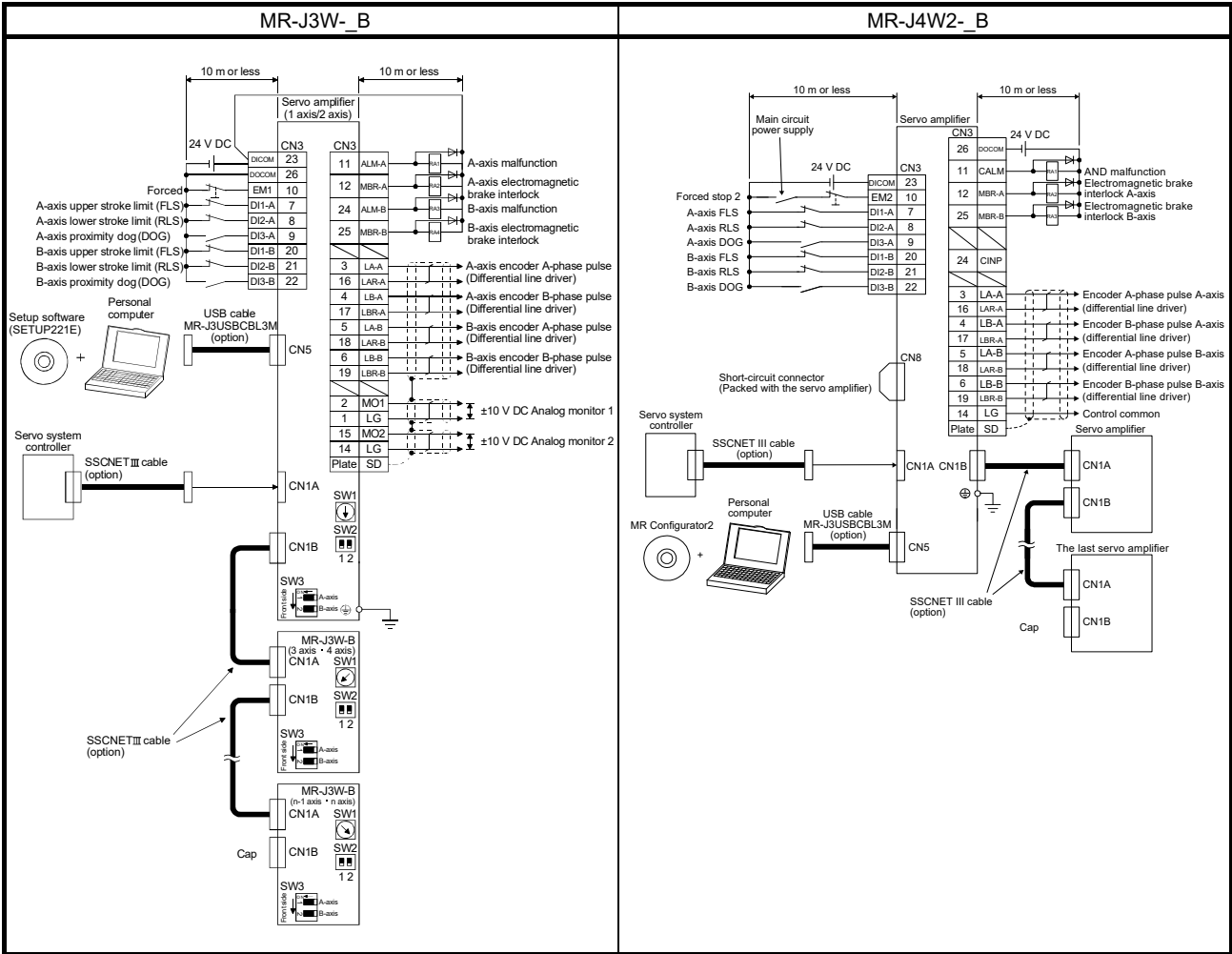

Part 4: Replacement of MR-J3W-_B with MR-J4W2-_B

3.5 List of Corresponding Connectors and Terminal Blocks

An example of connections with the peripheral equipment is shown below. Refer to the respective Instruction Manuals for details on the signals.

3.5.1 200 V class

(1) Comparison of connectors

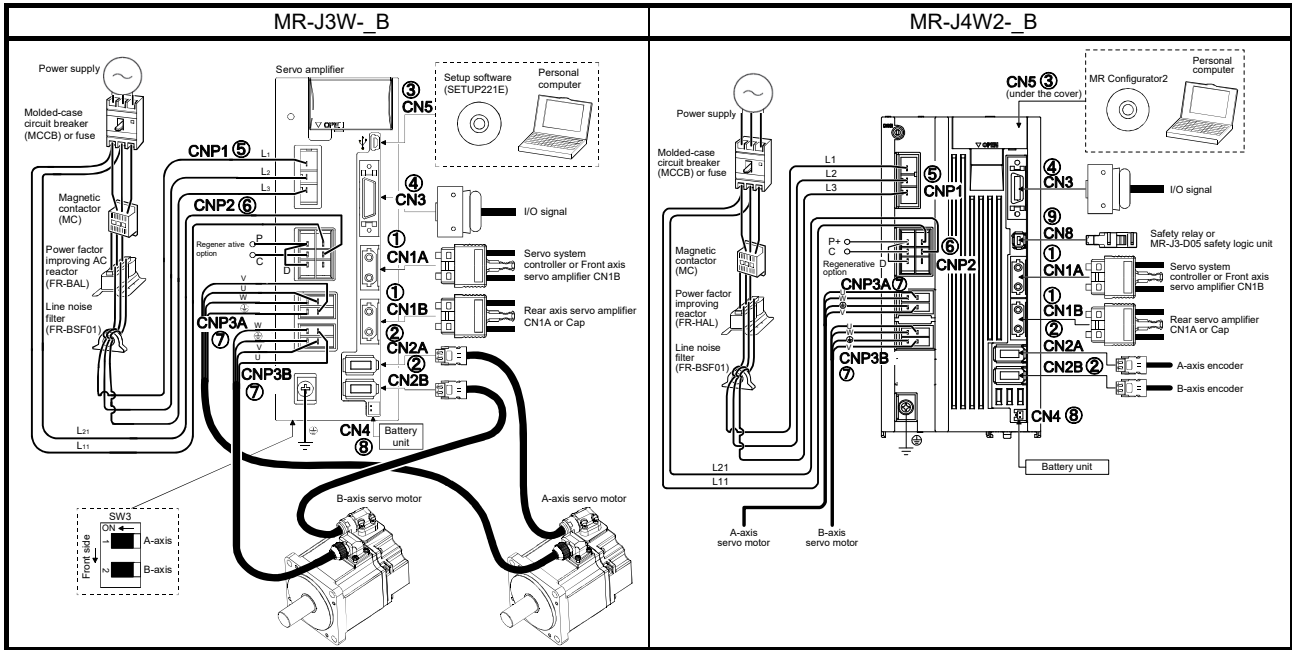

(2) List of connector and terminal block correspondence

MR-J3W-_B			MR-J4W2-_B			Precautions
No.	Connector name	Connector No.	No.	Connector name	Connector No.	
①	SSCNET III cable connector	CN1A	①	SSCNET III cable connector	CN1A	MR-J3W cables can be used as they are.
		CN1B			CN1B	
②	encoder connector	CN2A	②	encoder connector	CN2A	
		CN2B			CN2B	
③	USB communication connector	CN5	③	USB communication connector	CN5	
④	I/O signal connector	CN3	④	I/O signal connector	CN3	
⑤	Main circuit power connector	CNP1	⑤	Main circuit power connector	CNP1	MR-J3W connector can be used as they are.
⑥	Control circuit power connector	CNP2	⑥	Control circuit power connector	CNP2	
⑦	Servo motor power connector	CNP3A	⑦	Servo motor power output connector	CNP3A	
		CNP3B			CNP3B	
⑧	Battery connector	CN4	⑧	Battery connector	CN4	A new battery needs to be prepared. For details, refer to "MR-J4W2-_B/MR-J4W3-_B/MR-J4W2-0303B6 Servo Amplifier Instruction Manual".
⑨	STO input signal connector		⑨	STO input signal connector	CN8	When not using the STO in MR-J4W2, attach the short-circuit connector supplied with the servo amplifier to CN8.

Part 4: Replacement of MR-J3W-_B with MR-J4W2-_B







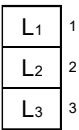
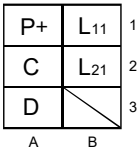
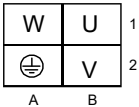
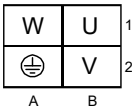

(3) Comparison of signals

MR-J3W-_B		Abbreviation	MR-J4W2-_B		
Connector pin assignment	Connector pin No.		Connector pin No.	Connector pin assignment	
CN3		CN3-1	CN3-1	CN3	
		CN3-2	CN3-2		
		CN3-3	CN3-3		
		CN3-4	CN3-4		
		CN3-5	CN3-5		
		CN3-6	CN3-6		
		CN3-7	CN3-7		
		CN3-8	CN3-8		
		CN3-9	CN3-9		
		CN3-10	CN3-10		
		CN3-11	CN3-11		
		CN3-12	CN3-12		
		CN3-13	CN3-13		
		CN3-14	CN3-14		
		CN3-15	CN3-15		
		CN3-16	CN3-16		
		CN3-17	CN3-17		
		CN3-18	CN3-18		
		CN3-19	CN3-19		
		CN3-20	CN3-20		
		CN3-21	CN3-21		
		CN3-22	CN3-22		
		CN3-23	CN3-23		
		CN3-24	CN3-24		
		CN3-25	CN3-25		
		CN3-26	CN3-26		

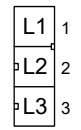
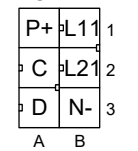
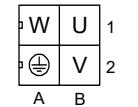
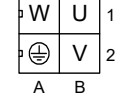
- Note 1. In the initial setting, EM2 is assigned to the CN3-10 pin. Set [Pr. PA04] to "0 0 __" when assigning EM1.
- Note 2. In the initial setting, CALM is assigned to the CN3-11 pin. Set [Pr. PD09] to "1 _ 0 3" when assigning ALM-A.
- Note 3. In the initial setting, MBR-C is assigned to the CN3-13 pin. Set [Pr. PD07] to "_ _ 0 0" when assigning Always off.
- Note 4. In the initial setting, CINP is assigned to the CN3-24 pin. Set [Pr. PD08] to "2 _ 0 3" when assigning ALM-B.
- Note 5. Because the MR-J4W2-_B servo amplifiers do not support analog monitors (MO1 and MO2), LG for MO1 or MO2 is not assigned. Use CN3-14 for the control common of the encoder output pulses.
DI1-C is assigned to the CN3-1 pin. Because the signal is for MR-J4W3-_B servo amplifier, it does not function for the MR-J4W2-_B servo amplifier (Always off).
- Note 6. MR-J4W2-_B servo amplifier does not support analog monitors (MO1 and MO2). DI2-C is assigned to the CN3-2 pin, and DI3-C is assigned to the CN3-15 pin. Because the signal is for MR-J4W3-_B servo amplifier, it does not function for the MR-J4W2-_B servo amplifier (Always off).

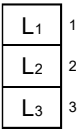
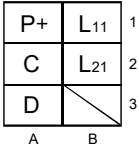
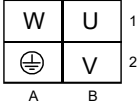
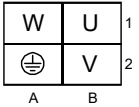
Part 4: Replacement of MR-J3W-_B with MR-J4W2-_B

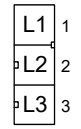
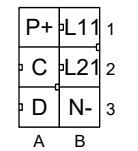
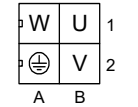
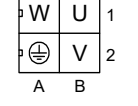
(4) Main circuit terminal block

MR-J3W-22B/MR-J3W-44B	MR-J4W2-22B/MR-J4W2-44B
<p>CNP1</p>  <p>CNP2</p>  <p>CNP3A</p>  <p>CNP3B</p>  <p>PE (⊕)</p>  <p>Screw Size: M4 Tightening torque: 1.2 [N•m]</p>	<p>CNP1</p>  <p>CNP2</p>  <p>CNP3A</p>  <p>CNP3B</p>  <p>PE</p>  <p>Screw Size: M4 Tightening torque: 1.2 [N•m]</p>
MR-J3W-77B/MR-J3W-1010B	MR-J4W2-77B/MR-J4W2-1010B
<p>CNP1</p>  <p>CNP2</p>  <p>CNP3A</p>  <p>CNP3B</p>  <p>PE (⊕)</p>  <p>Screw Size: M4 Tightening torque: 1.2 [N•m]</p>	<p>CNP1</p>  <p>CNP2</p>  <p>CNP3A</p>  <p>CNP3B</p>  <p>PE</p>  <p>Screw Size: M4 Tightening torque: 1.2 [N•m]</p>

Part 4: Replacement of MR-J3W-_B with MR-J4W2-_B

3.5.2 48 V DC/24 V DC class

(1) Comparison of connectors

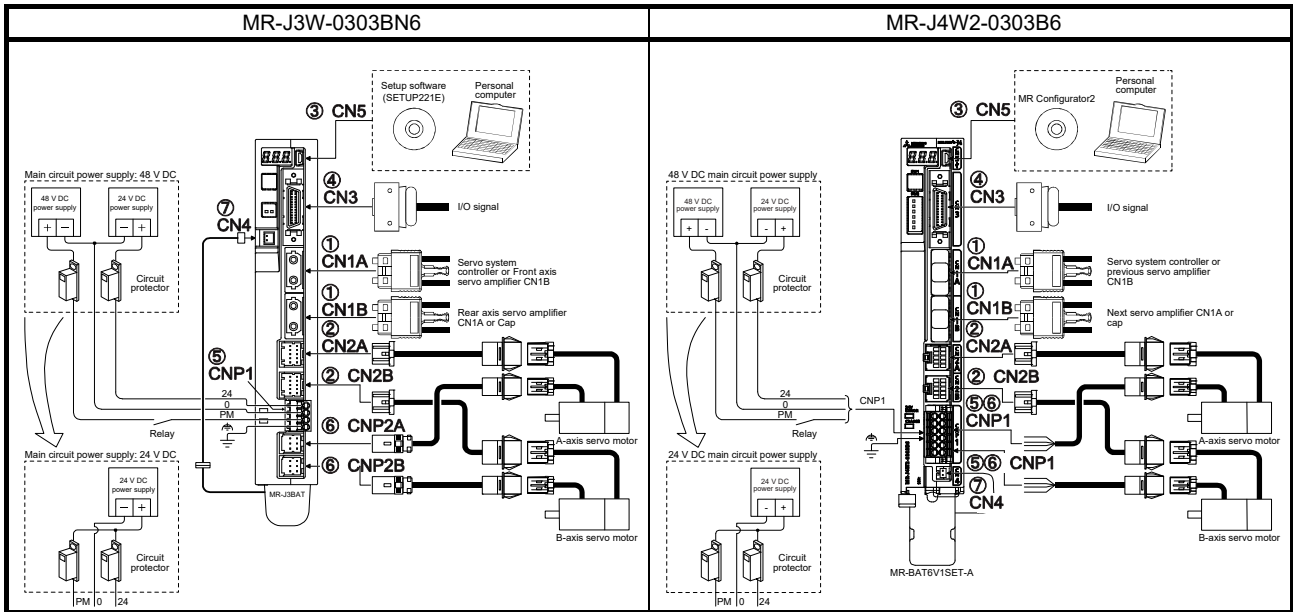

(2) List of connector and terminal block correspondence

MR-J3W-0303BN6			→	MR-J4W2-0303B6			Precautions
No.	Connector name	Connector No.	No.	Connector name	Connector No.		
①	SSCNET III cable connector	CN1A	①	SSCNET III cable connector	CN1A	MR-J3W cables can be used as they are.	
		CN1B			CN1B		
②	Encoder connector	CN2A	②	Encoder connector	CN2A		
		CN2B			CN2B		
③	USB communication connector	CN5	③	USB communication connector	CN5		
④	I/O signal connector	CN3	④	I/O signal connector	CN3		MR-J3W cables can be used as they are. Refer to (3) in this section for the connector pin assignment.
⑤	Main circuit power supply connector	CNP1	⑤	Main circuit power supply connector	CNP1	Replace the existing connectors with the ones supplied with the servo amplifier.	
⑥	Servo motor power connector	CNP2A	⑥	Servo motor power output connector		Replace the existing connectors with the ones supplied with the servo amplifier. They are different from the cables and connector of MR-J3W.	
		CNP2B					
⑦	Battery connector	CN4	⑦	Battery connector	CN4	A new battery needs to be prepared. For details, refer to "MR-J4W2-_B/MR-J4W3-_B/MR-J4W2-0303B6 Servo Amplifier Instruction Manual".	

Part 4: Replacement of MR-J3W-_B with MR-J4W2-_B

(3) Comparison of signals

MR-J3W-0303BN6		Signal abbreviation	MR-J4W2-0303B6		
Connector pin assignment	Connector pin No.		Connector pin No.	Connector pin assignment	
CN3		CN3-1	CN3-1	CN3	
		CN3-2	CN3-2		
		CN3-3	CN3-3		
		CN3-4	CN3-4		
		CN3-5	CN3-5		
		CN3-6	CN3-6		
		CN3-7	CN3-7		
		CN3-8	CN3-8		
		CN3-9	CN3-9		
		CN3-10	CN3-10		
		CN3-11	CN3-11		
		CN3-12	CN3-12		
		CN3-13	CN3-13		
		CN3-14	CN3-14		
		CN3-15	CN3-15		
		CN3-16	CN3-16		
		CN3-17	CN3-17		
		CN3-18	CN3-18		
		CN3-19	CN3-19		
		CN3-20	CN3-20		
		CN3-21	CN3-21		
		CN3-22	CN3-22		
		CN3-23	CN3-23		
		CN3-24	CN3-24		
		CN3-25	CN3-25		
		CN3-26	CN3-26		

- Note
1. As the initial value, EM2 is assigned to the CN3-10 pin. Set [Pr. PA04] to "0 0 _ _" to assign EM1.
 2. As the initial value, CALM is assigned to the CN3-11 pin. Set [Pr. PD09] to "1 _ 0 3" to assign ALM-A.
 3. As the initial value, MBR-C is assigned to the CN3-13 pin. Set [Pr. PD07] to "_ _ 0 0" to assign Always off.
 4. As the initial value, CINP is assigned to the CN3-24 pin. Set [Pr. PD08] to "2 _ 0 3" to assign ALM-B.

(4) Main circuit terminal block

MR-J3W-0303BN6		MR-J4W2-0303B6	
Screw size: M5 Tightening torque: 1.87 [N•m]		Screw size: M5 Tightening torque: 1.87 [N•m]	

Part 4: Replacement of MR-J3W-_B with MR-J4W2-_B

3.6 Comparison of Peripheral Equipment

POINT

- | |
|---|
| <ul style="list-style-type: none">● Refer to "Part 10: Replacement of Optional Peripheral Equipment". |
|---|

Part 4: Replacement of MR-J3W-__B with MR-J4W2-__B

3.7 Comparison of Parameters



CAUTION

- Never perform extreme adjustments and changes to the parameters, otherwise the operation may become unstable.
- If fixed values are written in the digits of a parameter, do not change these values.
- Do not change parameters for manufacturer setting.
- Do not enter any setting value other than those specified for each parameter.

POINT

- For the parameter converter function, refer to "Part 7: Common Reference Material".
- For details about parameter settings for replacement, Refer to "MR-J4W2-__B/MR-J4W3-__B/MR-J4W2-0303B6 Servo Amplifier Instruction Manual".

POINT

- With MR-J4-__B_ the deceleration to a stop function is enabled by factory settings. To disable the deceleration to a stop function, set [Pr.PA04] to "0 ___".

Part 4: Replacement of MR-J3W-_B with MR-J4W2-_B

3.7.1 Setting requisite parameters upon replacement

The parameters shown in this section are a minimum number of parameters that need to be set for simultaneous replacement. Depending on the settings of the currently used servo amplifier, parameters other than these may need to be set.

Parameter No.	Name	Precautions
PA01	Control type selection	In MR-J3W-_B, the maximum torque was set to 300% as the initial value. However, in MR-J4W2-_B, the maximum torque is set to 350% as the initial value when using the HG-KR servo motor. Refer to Part 9 "Review on Replacement of Motor", check the operation status on customer side, and revise the settings as required.
PA02	Regenerative option selection	The setting value must be changed according to the option model.
PA04	Function selection A-1 Servo forced stop selection	Forced stop deceleration function selection To configure the same settings as for MR-J3W-_B, select "Forced stop deceleration function disabled (with EM1 used)".
PA08	Gain adjustment mode selection	The setting value needs to be changed according to the auto tuning mode.
PA09	Auto tuning response	Auto tuning response setting Enter this setting value for replacement, referring to "3.7.3 Comparison of parameter details". It is necessary to make gain adjustment again when replacing. For details on how to make gain adjustments, refer to Chapter 6 of "MR-J4W2-_B/MR-J4W3-_B/MR-J4W2-0303B6 Servo Amplifier Instruction Manual". The setting value needs to be changed based on the standard machine resonance frequency.
PA10	In-position range	The setting needs to be changed depending on the servo motor.
PA15	Encoder output pulse	Used to set the encoder pulses (A-phase and B-phase) output by the servo amplifier.
PA19	Parameter writing inhibit	Change the setting value as necessary.
PB06	Load to motor inertia ratio	The unit system is different. (0.1-fold→0.01-fold) Pay attention to setting value.
PB07	Model loop gain	The unit system is different. (rad/s→0.1 rad/s)
PB08	Position loop gain	The unit system is different. (rad/s→0.1 rad/s)
PB13	Machine resonance suppression filter 1	Change the setting value according to the frequency and depth.
PB14	Notch shape selection 1	
PB15	Machine resonance suppression filter 2	
PB16	Notch shape selection 2	Change the setting value according to the frequency and depth.
PB29	Load to motor inertia ratio after gain switching	The unit system is different. (0.1-fold→0.01-fold) Pay attention to setting value.
PB30	Position loop gain after gain switching	It is necessary to convert the ratio to a value to change the setting value.
PB31	Speed loop gain after gain switching	It is necessary to convert the ratio to a value to change the setting value.
PB32	Speed integral compensation after gain switching	It is necessary to convert the ratio to a value to change the setting value.
PC05	Function selection C-2	Select a voltage to be connected to the main circuit power supply with an MR-J4W2-0303B6 servo amplifier. [Pr. PC05]: "_ 0 _ _" 48 V DC (Initial value) "_ 1 _ _" 24 V DC The setting of this digit in the J3 compatibility mode is the same as the MR-J3W-0303BN6 servo amplifier. Set it with [Pr. Po04]. [Pr. Po04]: "0 _ _ _" 48 V DC (Initial value) "1 _ _ _" 24 V DC The characteristics of the servo motor vary depending on whether the voltage of the main circuit is 48 V DC or 24 V DC.
PC09	Analog monitor 1 output	Analog monitors (MO1/MO2) support MR-J4W2-0303B6 only. When MO1/MO2 are used with 200 V of MR-J3W-_B, please consider replacing the servo amplifier with 2 MR-J4 single-axis servo amplifiers.
PC10	Analog monitor 2 output	
PC11	Analog monitor 1 offset	
PC12	Analog monitor 2 offset	

Part 4: Replacement of MR-J3W-_B with MR-J4W2-_B

3.7.2 Parameter comparison list

POINT
<ul style="list-style-type: none"> ● The parameter whose symbol preceded by * can be validated with the following conditions. <ul style="list-style-type: none"> * : Turn off the power and then on again, or reset the controller after setting the parameter. ** : Turn off the power and then on again after setting the parameter. ● How to set parameters <ul style="list-style-type: none"> Each: Set parameters for each axis of A and B. Common: Set parameters for common axis of A and B. Be sure to set the same value to all axes. ● The same values are set as default for all axes. ● Setting an out of range value to each parameter will trigger [AL. 37 Parameter error].

MR-J3W-_B parameters						MR-J4W2-_B parameters					
No.	Symbol	Parameter name	Setting	Factory setting	Customer setting value	No.	Symbol	Parameter name	Setting	Factory setting	Customer setting value
PA01	**STY	Control mode	Each axis	0000h		PA01	**STY	Operation mode	Each axis	1000h	
PA02	**REG	Regenerative option	Common	0000h		PA02	**REG	Regenerative option	Common	0000h	
PA03	*ABS	Absolute position detection system	Each axis	0000h		PA03	*ABS	Absolute position detection system	Each axis	0000h	
PA04	*AOP1	Function selection A-1	Common	0000h		PA04	*AOP1	Function selection A-1	Common	2000h	
PA05	\	This parameter is not used. Do not change the value.	\	0		PA05	\	For manufacturer setting	\	10000	
PA06				1		PA06				1	
PA07				1		PA07				1	
PA08	ATU	Auto tuning mode	Each axis	0001h		PA08	ATU	Auto tuning mode	Each axis	0001h	
PA09	RSP	Auto tuning response	Each axis	12		PA09	RSP	Auto tuning response	Each axis	16	
PA10	INP	In-position range	Each axis	100		PA10	INP	In-position range	Each axis	1600	
PA11	\	This parameter is not used. Do not change the value.	\	1000.0		PA11	\	For manufacturer setting	\	1000.0	
PA12				1000.0		PA12				1000.0	
PA13				0000h		PA13				0000h	
PA14	*POL	Rotation direction selection	Each axis	0		PA14	*POL	Rotation direction selection/travel direction selection	Each axis	0	
PA15	*ENR	Encoder output pulses	Each axis	4000		PA15	*ENR	Encoder output pulses	Each axis	4000	
PA16	*ENR2	Encoder output pulses 2	Each axis	0		PA16	*ENR2	Encoder output pulses 2	Each axis	1	
PA17	\	This parameter is not used. Do not change the value.	\	0000h		PA17	\	For manufacturer setting	\	0000h	
PA18				0000h		PA18				0000h	
PA19	*BLK	Parameter write inhibit	Each axis	000Bh		PA19	*BLK	Parameter writing inhibit	Each axis	00ABh	
PB01	FILT	Adaptive tuning mode (Adaptive filter II)	Each axis	0000h		PB01	FILT	Adaptive tuning mode (adaptive filter II)	Each axis	0000h	
PB02	VRFT	Vibration suppression control tuning mode (advanced vibration suppression control)	Each axis	0000h		PB02	VRFT	Vibration suppression control tuning mode (advanced vibration suppression control II)	Each axis	0000h	
PB03	\	This parameter is not used. Do not change the value.	\	0		PB03	\	Torque feedback loop gain	\	18000	
PB04				0		PB04				0	
PB04	FFC	Feed forward gain	Each axis	0		PB04	FFC	Feed forward gain	Each axis	0	

Part 4: Replacement of MR-J3W-_B with MR-J4W2-_B

MR-J3W-_B parameters						MR-J4W2-_B parameters					
No.	Symbol	Parameter name	Setting	Factory setting	Customer setting value	No.	Symbol	Parameter name	Setting	Factory setting	Customer setting value
PB05		This parameter is not used. Do not change the value.		500		PB05		For manufacturer setting		500	
PB06	GD2	Load to motor inertia moment ratio	Each axis	7.0		PB06	GD2	Load to motor inertia ratio/load to motor mass ratio	Each axis	7.00	
PB07	PG1	Model loop gain	Each axis	24		PB07	PG1	Model loop gain	Each axis	15.0	
PB08	PG2	Position loop gain	Each axis	37		PB08	PG2	Position loop gain	Each axis	37.0	
PB09	VG2	Speed loop gain	Each axis	823		PB09	VG2	Speed loop gain	Each axis	823	
PB10	VIC	Speed integral compensation	Each axis	33.7		PB10	VIC	Speed integral compensation	Each axis	33.7	
PB11	VDC	Speed differential compensation	Each axis	980		PB11	VDC	Speed differential compensation	Each axis	980	
PB12		This parameter is not used. Do not change the value.		0		PB12	OVA	Overshoot amount compensation	Each axis	0	
PB13	NH1	Machine resonance suppression filter 1	Each axis	4500		PB13	NH1	Machine resonance suppression filter 1	Each axis	4500	
PB14	NHQ1	Notch shape selection 1	Each axis	0000h		PB14	NHQ1	Notch shape selection 1	Each axis	0000h	
PB15	NH2	Machine resonance suppression filter 2	Each axis	4500		PB15	NH2	Machine resonance suppression filter 2	Each axis	4500	
PB16	NHQ2	Notch shape selection 2	Each axis	0000h		PB16	NHQ2	Notch shape selection 2	Each axis	0000h	
PB17		Automatic setting parameter				PB17	NHF	Shaft resonance suppression filter	Each axis	0000h	
PB18	LPF	Low-pass filter setting	Each axis	3141		PB18	LPF	Low-pass filter setting	Each axis	3141	
PB19	VRF1	Vibration suppression control vibration frequency setting	Each axis	100.0		PB19	VRF11	Vibration suppression control 1 - Vibration frequency	Each axis	100.0	
PB20	VRF2	Vibration suppression control resonance frequency setting	Each axis	100.0		PB20	VRF12	Vibration suppression control 1 - Resonance frequency	Each axis	100.0	
PB21		This parameter is not used. Do not change the value.		0.00		PB21	VRF13	Vibration suppression control 1 - Vibration frequency damping	Each axis	0.00	
PB22				0.00		PB22	VRF14	Vibration suppression control 1 - Resonance frequency damping	Each axis	0.00	
PB23	VFBF	Low-pass filter selection	Each axis	0000h		PB23	VFBF	Low-pass filter selection	Each axis	0000h	
PB24	*MVS	Slight vibration suppression control selection	Each axis	0000h		PB24	*MVS	Slight vibration suppression control	Each axis	0000h	
PB25		This parameter is not used. Do not change the value.		0000h		PB25	*BOP1	Function selection B-1	Each axis	0000h	
PB26	*CDP	Gain changing selection	Each axis	0000h		PB26	*CDP	Gain switching function	Each axis	0000h	
PB27	CDL	Gain changing condition	Each axis	10		PB27	CDL	Gain switching condition	Each axis	10	
PB28	CDT	Gain changing time constant	Each axis	1		PB28	CDT	Gain switching time constant	Each axis	1	
PB29	GD2B	Gain changing load to motor inertia moment ratio	Each axis	7.0		PB29	GD2B	Load to motor inertia ratio/load to motor mass ratio after gain switching	Each axis	7.00	
PB30	PG2B	Gain changing position loop gain	Each axis	37		PB30	PG2B	Position loop gain after gain switching	Each axis	0.0	
PB31	VG2B	Gain changing speed loop gain	Each axis	823		PB31	VG2B	Speed loop gain after gain switching	Each axis	0	
PB32	VICB	Gain changing speed integral compensation	Each axis	33.7		PB32	VICB	Speed integral compensation after gain switching	Each axis	0.0	

Part 4: Replacement of MR-J3W-_B with MR-J4W2-_B

MR-J3W-_B parameters						MR-J4W2-_B parameters					
No.	Symbol	Parameter name	Setting	Factory setting	Customer setting value	No.	Symbol	Parameter name	Setting	Factory setting	Customer setting value
PB33	VRF1B	Gain changing vibration suppression control vibration frequency setting	Each axis	100.0		PB33	VRF11B	Vibration suppression control 1 - Vibration frequency after gain switching	Each axis	0.0	
PB34	VRF2B	Gain changing vibration suppression control resonance frequency setting	Each axis	100.0		PB34	VRF12B	Vibration suppression control 1 - Resonance frequency after gain switching	Each axis	0.0	
PB35		This parameter is not used. Do not change the value.		0.00		PB35	VRF13B	Vibration suppression control 1 - Resonance frequency after gain switching	Each axis	0.0	
PB36				0.00		PB36	VRF14B	Vibration suppression control 1 - Vibration frequency damping after gain switching	Each axis	0.0	
PB37				100		PB37		For manufacturer setting		1600	
PB38				0.0		PB38				0.00	
PB39				0.0		PB39				0.00	
PB40				0.0		PB40				0.00	
PB41				1125		PB41				0	
PB42				1125		PB42				0	
PB43				0004h		PB43				0000h	
PB44				0.0		PB44				0.00	
PB45				0000h		PB45	CNHF	Command notch filter	Each axis	0000h	
PC01	ERZ		Error excessive alarm level	Each axis	0		PC01	ERZ	Error excessive alarm level	Each axis	0
PC02	MBR	Electromagnetic brake sequence output	Each axis	0		PC02	MBR	Electromagnetic brake sequence output	Each axis	0	
PC03	*ENRS	Encoder output pulses selection	Each axis	0010h		PC03	*ENRS	Encoder output pulse selection	Each axis	0000h	
PC04	**COP1	Function selection C-1	Each axis	0000h		PC04	**COP1	Function selection C-1	Each axis	0000h	
PC05	**COP2	Function selection C-2	Each axis	0000h		PC05	**COP2	Function selection C-2	Each axis	0000h	
PC06	*COP3	Function selection C-3	Each axis	0000h		PC06	*COP3	Function selection C-3	Each axis	0000h	
PC07	ZSP	Zero speed	Each axis	50		PC07	ZSP	Zero speed	Each axis	50	
PC08		This parameter is not used. Do not change the value.		0		PC08	OSL	Overspeed alarm detection level	Each axis	0	
PC09	MOD1		Analog monitor 1 output	Common	0000h		PC09	MOD1	Analog monitor 1 output	Common	0000h
PC10	MOD2	Analog monitor 2 output	Common	0001h		PC10	MOD2	Analog monitor 2 output	Common	0001h	
PC11	MO1	Analog monitor 1 offset	Common	0		PC11	MO1	Analog monitor 1 offset	Common	0	
PC12	MO2	Analog monitor 2 offset	Common	0		PC12	MO2	Analog monitor 2 offset	Common	0	
PC13		This parameter is not used. Do not change the value.		0		PC13	MOSDL	Analog monitor - Feedback position output standard data - Low	Each axis	0	
PC14				0		PC14	MOSDH	Analog monitor - Feedback position output standard data - High	Each axis	0	
PC15	SNO	Station number selection	Common	0		PC15		For manufacturer setting		0	
PC16		This parameter is not used. Do not change the value.		0000h		PC16				0000h	
PC17	**COP4		Function selection C-4	Each axis	0000h		PC17	**COP4	Function selection C-4	Each axis	0000h
PC18		This parameter is not used. Do not change the value.		0000h		PC18	*COP5	Function selection C-5	Common	0000h	
PC19				0000h		PC19		For manufacturer setting		0000h	
PC20				0000h		PC20	*COP7		Function selection C-7	Common	0000h
PC21	*BPS	Alarm history clear	Each axis	0000h		PC21	*BPS	Alarm history clear	Each axis	0000h	

Part 4: Replacement of MR-J3W-_B with MR-J4W2-_B

MR-J3W-_B parameters						MR-J4W2-_B parameters							
No.	Symbol	Parameter name	Setting	Factory setting	Customer setting value	No.	Symbol	Parameter name	Setting	Factory setting	Customer setting value		
PC22		This parameter is not used. Do not change the value.		0000h		PC22		For manufacturer setting		0			
PC23				0000h		PC23		0000h				0000h	
PC24				0000h		PC24	RSBR	Forced stop deceleration time constant	Each axis	100			
PC25				0000h		PC25		For manufacturer setting		0			
PC26				0000h		PC26		0000h				0000h	
PC27				0000h		PC27	**COP9	Function selection C-9	Each axis	0000h			
PC28				0000h		PC28		For manufacturer setting		0000h			
PC29				0000h		PC29	*COPB	Function selection C-B	Each axis	0000h			
PC30				0000h		PC30		For manufacturer setting		0			
PC31				0000h		PC31	RSUP1	Vertical axis freefall prevention compensation amount	Each axis	0			
PC32				0000h		PC32		For manufacturer setting		0000h			
PD01				0000h		PD01		For manufacturer setting		0000h			
PD02				0000h		PD02	*DIA2	Input signal automatic on selection 2	Each axis	0000h			
PD03				0020h		PD03		For manufacturer setting		0020h			
PD04				0021h		PD04		0021h				0021h	
PD05				0022h		PD05		0022h				0022h	
PD06	0000h		PD06		0000h				0000h				
PD07	*D01	Output signal device selection 1 (CN3-12 for A-axis and CN3-25 for B-axis)	Each axis	0005h		PD07	*DO1	Output device selection 1	Each axis	0005h			
PD08		This parameter is not used. Do not change the value.		0004h		PD08	*DO2	Output device selection 2	Common	0004h			
PD09	*D03	Output signal device selection 3 (CN3-11 for A-axis and CN3-24 for B-axis)	Each axis	0003h		PD09	*DO3	Output device selection 3	Common	0003h			
PD10		This parameter is not used. Do not change the value.		0000h		PD10		For manufacturer setting		0000h			
PD11				0004h		PD11	*DIF	Input filter setting (Note)	Common	0004h			
PD12				0000h		PD12	*DOP1	Function selection D-1	Each axis	0000h			
PD13				0000h		PD13		For manufacturer setting		0000h			
PD14	*DOP3	Function selection D-3	Each axis	0000h		PD14	*DOP3	Function selection D-3	Each axis	0000h			
PD15		This parameter is not used. Do not change the value.		0000h		PD15		For manufacturer setting		0000h			
PD16				0000h		PD16		0000h				0000h	
PD17				0000h		PD17		0000h				0000h	
PD18				0000h		PD18		0000h				0000h	
PD19				0000h		PD19		0000h				0000h	
PD20				0		PD20		0				0	
PD21				0		PD21		0				0	
PD22				0		PD22		0				0	
PD23				0		PD23		0				0	
PD24				0000h		PD24		0000h				0000h	
PD25				0000h		PD25		0000h				0000h	
PD26				0000h		PD26		0000h				0000h	
PD27				0000h		PD27		0000h				0000h	
PD28				0000h		PD28		0000h				0000h	
PD29				0000h		PD29		0000h				0000h	
PD30				0000h		PD30		0				0	
PD31				0000h		PD31		0				0	
PD32				0000h		PD32		0				0	

Note. Refer to the servo system controller instruction manual for the setting.

Part 4: Replacement of MR-J3W-_B with MR-J4W2-_B

3.7.3 Comparison of parameter details

POINT
● "x" in the "Setting digit" columns means which digit to set a value.

MR-J3W-_B			MR-J4W2-_B		
No.	Name and function	Initial value	No.	Name and function	Initial value
PA01	<p>Control mode</p> <p>Turn off the power and then on again after setting the parameter to validate the parameter value.</p> <p>Select the control mode.</p> <p>This parameter is set as "__ 0_" in the initial setting.</p> <p>0 0 x 0:</p> <p>Control mode selection</p> <p>0: Rotary servo motor</p>	0000h	PA01	<p>Operation mode</p> <p>Select an operation mode.</p> <p>___ x:</p> <p>For manufacturer setting</p>	0h
			<p>__ x _:</p> <p>Operation mode selection</p> <p>0: Standard control mode</p> <p>Setting other than above will result in [AL. 37 Parameter error].</p> <p>For MR-J4W2-0303B6 servo amplifiers, this digit cannot be used other than the initial value.</p>	0h	
			<p>_ x _ _</p> <p>For manufacturer setting</p>	0h	
			<p>x _ _ _</p> <p>Compatibility mode selection</p> <p>To change this digit, use an application software "MR Mode Change". When you change it without the application, [AL. 3E Operation mode error] will occur.</p> <p>Set the digit as common setting.</p> <p>0: J3 compatibility mode</p> <p>1: J4 mode</p>	1h	
PA02	<p>Regenerative option</p> <p>Turn off the power and then on again after setting the parameter to validate the parameter value.</p> <p>Wrong setting may cause the regenerative option to burn.</p> <p>If the regenerative option selected is not for use with the servo amplifier, [AL. 37 Parameter error] occurs.</p> <p>The MR-RB3B can be used with the servo amplifier whose software version is B3 or later.</p> <p>Set this parameter when using the regenerative option.</p> <p>For MR-J4W2-0303BN6 servo amplifiers, this digit cannot be used other than the initial value.</p> <p>0 0 x x:</p> <p>Selection of regenerative option</p> <p>00: Regenerative option is not used (built-in regenerative resistor is used)</p> <p>0D: MR-RB14</p> <p>0E: MR-RB34</p> <p>10: MR-RB3B</p>	0000h	PA02	<p>Regenerative option</p> <p>Select a regenerative option.</p> <p>Incorrect setting may cause the regenerative option to burn.</p> <p>If a selected regenerative option is not for use with the servo amplifier, [AL. 37 Parameter error] occurs.</p> <p>For MR-J4W2-0303B6 servo amplifiers, this digit cannot be used other than the initial value.</p> <p>__ x x:</p> <p>Regenerative option selection</p> <p>00: Regenerative option is not used. (Built-in regenerative resistor is used.)</p> <p>0B: MR-RB3N</p> <p>0D: MR-RB14</p> <p>0E: MR-RB34</p> <p>10: MR-RB3B (available with servo motors for MR-J3)</p>	00h
			<p>_ x _ _</p> <p>For manufacturer setting</p>	0h	
			<p>x _ _ _</p> <p>For manufacturer setting</p>	0h	

Part 4: Replacement of MR-J3W-_B with MR-J4W2-_B

MR-J3W-_B			MR-J4W2-_B																								
No.	Name and function	Initial value	No.	Name and function	Initial value																						
PA03	<p>Absolute position detection system</p> <p>Turn off the power and then on again, or reset the controller after setting the parameter to validate the parameter value.</p> <p>This parameter cannot be used in the speed control mode.</p> <p>Set this parameter when using the absolute position detection system in the position control mode.</p> <p>0 0 0 x:</p> <p>Selection of absolute position detection system</p> <p>0: Used in incremental system</p> <p>1: Used in absolute position detection system</p>	0000h	PA03	<p>Absolute position detection system</p> <p>Set this parameter when using the absolute position detection system. The parameter is not available in the speed control mode and torque control mode.</p>																							
			<p>__ _ x:</p> <p>Absolute position detection system selection</p> <p>0: Disabled (used in incremental system)</p> <p>1: Enabled (used in absolute position detection system)</p>	0h																							
				<p>__ x _:</p> <p>For manufacturer setting</p>	0h																						
				<p>_ x _ _:</p> <p>For manufacturer setting</p>	0h																						
				<p>x _ _ _:</p> <p>For manufacturer setting</p>	0h																						
PA04	<p>Function selection A-1</p> <p>Turn off the power and then on again, or reset the controller after setting the parameter to validate the parameter value.</p> <p>The servo forced stop function is avoidable.</p> <p>0 x 0 0:</p> <p>Selection of servo forced stop</p> <p>0: Valid (Forced stop (EM1) is used.)</p> <p>1: Invalid (Forced stop (EM1) is not used.)</p> <p>When not using the forced stop (EM1) of servo amplifier, set the selection of servo forced stop to Invalid (_ 1 _ _). At this time, the forced stop (EM1) automatically turns on inside the servo amplifier.</p>	0000h	PA04	<p>Function selection A-1</p> <p>Select a forced stop input and forced stop deceleration function.</p>																							
			<p>__ _ x:</p> <p>For manufacturer setting</p>	0h																							
				<p>__ x _:</p> <p>For manufacturer setting</p>	0h																						
				<p>_ x _ _:</p> <p>Servo forced stop selection</p> <p>0: Enabled (The forced stop input EM2 or EM1 is used.)</p> <p>1: Disabled (The forced stop input EM2 and EM1 are not used.)</p> <p>Refer to table 4.1 for details.</p>	0h																						
				<p>x _ _ _:</p> <p>Forced stop deceleration function selection</p> <p>0: Forced stop deceleration function disabled (EM1)</p> <p>2: Forced stop deceleration function enabled (EM2)</p> <p>Refer to table 4.1 for details.</p>	2h																						
<p>Table 4.1 Deceleration method</p> <table border="1" style="width: 100%; border-collapse: collapse;"> <thead> <tr> <th rowspan="2">Setting value</th> <th rowspan="2">EM2/EM1</th> <th colspan="2">Deceleration method</th> </tr> <tr> <th>EM2 or EM1 is off</th> <th>Alarm occurred</th> </tr> </thead> <tbody> <tr> <td>0 0 _ _</td> <td>EM1</td> <td>MBR (Electromagnetic brake interlock) turns off without the forced stop deceleration.</td> <td>MBR (Electromagnetic brake interlock) turns off without the forced stop deceleration.</td> </tr> <tr> <td>2 0 _ _</td> <td>EM2</td> <td>MBR (Electromagnetic brake interlock) turns off after the forced stop deceleration.</td> <td>MBR (Electromagnetic brake interlock) turns off after the forced stop deceleration.</td> </tr> <tr> <td>0 1 _ _</td> <td>Not using EM2 and EM1</td> <td style="text-align: center;">/</td> <td>MBR (Electromagnetic brake interlock) turns off without the forced stop deceleration.</td> </tr> <tr> <td>2 1 _ _</td> <td>Not using EM2 and EM1</td> <td style="text-align: center;">/</td> <td>MBR (Electromagnetic brake interlock) turns off after the forced stop deceleration.</td> </tr> </tbody> </table>						Setting value	EM2/EM1	Deceleration method		EM2 or EM1 is off	Alarm occurred	0 0 _ _	EM1	MBR (Electromagnetic brake interlock) turns off without the forced stop deceleration.	MBR (Electromagnetic brake interlock) turns off without the forced stop deceleration.	2 0 _ _	EM2	MBR (Electromagnetic brake interlock) turns off after the forced stop deceleration.	MBR (Electromagnetic brake interlock) turns off after the forced stop deceleration.	0 1 _ _	Not using EM2 and EM1	/	MBR (Electromagnetic brake interlock) turns off without the forced stop deceleration.	2 1 _ _	Not using EM2 and EM1	/	MBR (Electromagnetic brake interlock) turns off after the forced stop deceleration.
Setting value	EM2/EM1	Deceleration method																									
		EM2 or EM1 is off	Alarm occurred																								
0 0 _ _	EM1	MBR (Electromagnetic brake interlock) turns off without the forced stop deceleration.	MBR (Electromagnetic brake interlock) turns off without the forced stop deceleration.																								
2 0 _ _	EM2	MBR (Electromagnetic brake interlock) turns off after the forced stop deceleration.	MBR (Electromagnetic brake interlock) turns off after the forced stop deceleration.																								
0 1 _ _	Not using EM2 and EM1	/	MBR (Electromagnetic brake interlock) turns off without the forced stop deceleration.																								
2 1 _ _	Not using EM2 and EM1	/	MBR (Electromagnetic brake interlock) turns off after the forced stop deceleration.																								

Part 4: Replacement of MR-J3W-_B with MR-J4W2-_B

MR-J3W-_B			MR-J4W2-_B																																																																																																																																																																										
No.	Name and function	Initial value	No.	Name and function	Initial value																																																																																																																																																																								
PA08	<p>Auto tuning mode</p> <p>This parameter cannot be used in the torque control mode.</p> <p>Make gain adjustment using auto tuning. Auto tuning mode ([Pr. PA08])</p> <p>Select the gain adjustment mode.</p> <p>0 0 0 x:</p> <p>Gain adjustment mode setting</p> <p>0: Interpolation mode (Automatically set parameter No. PB06/PB08/PB09/PB10)</p> <p>1: Auto tuning mode 1 (Automatically set parameter No. [Pr. PB06/ PB07/PB08/PB09/PB10])</p> <p>2: Auto tuning mode 2 (Automatically set parameter No. [Pr. PB07/ PB08/PB09/PB10])</p> <p>3: Manual mode</p> <p>The parameters have the following names.</p> <table border="1"> <thead> <tr> <th>Parameter No.</th> <th>Name</th> </tr> </thead> <tbody> <tr> <td>PB06</td> <td>Load to motor inertia moment ratio</td> </tr> <tr> <td>PB07</td> <td>Model loop gain</td> </tr> <tr> <td>PB08</td> <td>Position loop gain</td> </tr> <tr> <td>PB09</td> <td>Speed loop gain</td> </tr> <tr> <td>PB10</td> <td>Speed integral compensation</td> </tr> </tbody> </table>	Parameter No.	Name	PB06	Load to motor inertia moment ratio	PB07	Model loop gain	PB08	Position loop gain	PB09	Speed loop gain	PB10	Speed integral compensation	0001h	PA08	<p>Auto tuning mode</p> <p>Select a gain adjustment mode.</p> <p>___ x:</p> <p>Gain adjustment mode selection</p> <p>0: 2 gain adjustment mode 1 (interpolation mode)</p> <p>1: Auto tuning mode 1</p> <p>2: Auto tuning mode 2</p> <p>3: Manual mode</p> <p>4: 2 gain adjustment mode 2</p> <p>Refer to table 4.2 for details.</p> <p>Table 4.2 Gain adjustment mode selection</p> <table border="1"> <thead> <tr> <th>Setting value</th> <th>Gain adjustment mode</th> <th>Automatically adjusted parameter</th> </tr> </thead> <tbody> <tr> <td>___ 0</td> <td>2 gain adjustment mode 1 (interpolation mode)</td> <td>[Pr. PB06 Load to motor inertia ratio/load to motor mass ratio] [Pr. PB08 Position loop gain] [Pr. PB09 Speed loop gain] [Pr. PB10 Speed integral compensation]</td> </tr> <tr> <td>___ 1</td> <td>Auto tuning mode 1</td> <td>[Pr. PB06 Load to motor inertia ratio/load to motor mass ratio] [Pr. PB07 Model loop gain] [Pr. PB08 Position loop gain] [Pr. PB09 Speed loop gain] [Pr. PB10 Speed integral compensation]</td> </tr> <tr> <td>___ 2</td> <td>Auto tuning mode 2</td> <td>[Pr. PB07 Model loop gain] [Pr. PB08 Position loop gain] [Pr. PB09 Speed loop gain] [Pr. PB10 Speed integral compensation]</td> </tr> <tr> <td>___ 3</td> <td>Manual mode</td> <td></td> </tr> <tr> <td>___ 4</td> <td>2 gain adjustment mode 2</td> <td>[Pr. PB08 Position loop gain] [Pr. PB09 Speed loop gain] [Pr. PB10 Speed integral compensation]</td> </tr> </tbody> </table>	Setting value	Gain adjustment mode	Automatically adjusted parameter	___ 0	2 gain adjustment mode 1 (interpolation mode)	[Pr. PB06 Load to motor inertia ratio/load to motor mass ratio] [Pr. PB08 Position loop gain] [Pr. PB09 Speed loop gain] [Pr. PB10 Speed integral compensation]	___ 1	Auto tuning mode 1	[Pr. PB06 Load to motor inertia ratio/load to motor mass ratio] [Pr. PB07 Model loop gain] [Pr. PB08 Position loop gain] [Pr. PB09 Speed loop gain] [Pr. PB10 Speed integral compensation]	___ 2	Auto tuning mode 2	[Pr. PB07 Model loop gain] [Pr. PB08 Position loop gain] [Pr. PB09 Speed loop gain] [Pr. PB10 Speed integral compensation]	___ 3	Manual mode		___ 4	2 gain adjustment mode 2	[Pr. PB08 Position loop gain] [Pr. PB09 Speed loop gain] [Pr. PB10 Speed integral compensation]	1h																																																																																																																																										
	Parameter No.	Name																																																																																																																																																																											
PB06	Load to motor inertia moment ratio																																																																																																																																																																												
PB07	Model loop gain																																																																																																																																																																												
PB08	Position loop gain																																																																																																																																																																												
PB09	Speed loop gain																																																																																																																																																																												
PB10	Speed integral compensation																																																																																																																																																																												
Setting value	Gain adjustment mode	Automatically adjusted parameter																																																																																																																																																																											
___ 0	2 gain adjustment mode 1 (interpolation mode)	[Pr. PB06 Load to motor inertia ratio/load to motor mass ratio] [Pr. PB08 Position loop gain] [Pr. PB09 Speed loop gain] [Pr. PB10 Speed integral compensation]																																																																																																																																																																											
___ 1	Auto tuning mode 1	[Pr. PB06 Load to motor inertia ratio/load to motor mass ratio] [Pr. PB07 Model loop gain] [Pr. PB08 Position loop gain] [Pr. PB09 Speed loop gain] [Pr. PB10 Speed integral compensation]																																																																																																																																																																											
___ 2	Auto tuning mode 2	[Pr. PB07 Model loop gain] [Pr. PB08 Position loop gain] [Pr. PB09 Speed loop gain] [Pr. PB10 Speed integral compensation]																																																																																																																																																																											
___ 3	Manual mode																																																																																																																																																																												
___ 4	2 gain adjustment mode 2	[Pr. PB08 Position loop gain] [Pr. PB09 Speed loop gain] [Pr. PB10 Speed integral compensation]																																																																																																																																																																											
<p>__ x _:</p> <p>For manufacturer setting</p> <p>_ x _ _:</p> <p>For manufacturer setting</p> <p>x _ _ _:</p> <p>For manufacturer setting</p>	0h																																																																																																																																																																												
PA09	<p>Auto tuning response</p> <p>If the machine hunts or generates large gear sound, decrease the set value. To improve performance, e.g. shorten the settling time, increase the set value.</p> <table border="1"> <thead> <tr> <th>Setting value</th> <th>Response</th> <th>Guideline for machine resonance frequency [Hz]</th> <th>Setting value</th> <th>Response</th> <th>Guideline for machine resonance frequency [Hz]</th> </tr> </thead> <tbody> <tr><td>1</td><td rowspan="15">Low response ↑</td><td>10.0</td><td>17</td><td rowspan="15">Middle response ↑</td><td>67.1</td></tr> <tr><td>2</td><td>11.3</td><td>18</td><td>75.6</td></tr> <tr><td>3</td><td>12.7</td><td>19</td><td>85.2</td></tr> <tr><td>4</td><td>14.3</td><td>20</td><td>95.9</td></tr> <tr><td>5</td><td>16.1</td><td>21</td><td>108.0</td></tr> <tr><td>6</td><td>18.1</td><td>22</td><td>121.7</td></tr> <tr><td>7</td><td>20.4</td><td>23</td><td>137.1</td></tr> <tr><td>8</td><td>23.0</td><td>24</td><td>154.4</td></tr> <tr><td>9</td><td>25.9</td><td>25</td><td>173.9</td></tr> <tr><td>10</td><td>29.2</td><td>26</td><td>195.9</td></tr> <tr><td>11</td><td>32.9</td><td>27</td><td>220.6</td></tr> <tr><td>12</td><td>37.0</td><td>28</td><td>248.5</td></tr> <tr><td>13</td><td>41.7</td><td>29</td><td>279.9</td></tr> <tr><td>14</td><td>47.0</td><td>30</td><td>315.3</td></tr> <tr><td>15</td><td>52.9</td><td>31</td><td>355.1</td></tr> <tr><td>16</td><td>Middle response ↓</td><td>59.6</td><td>32</td><td>High response ↓</td><td>400.0</td></tr> </tbody> </table>	Setting value	Response	Guideline for machine resonance frequency [Hz]	Setting value	Response	Guideline for machine resonance frequency [Hz]	1	Low response ↑	10.0	17	Middle response ↑	67.1	2	11.3	18	75.6	3	12.7	19	85.2	4	14.3	20	95.9	5	16.1	21	108.0	6	18.1	22	121.7	7	20.4	23	137.1	8	23.0	24	154.4	9	25.9	25	173.9	10	29.2	26	195.9	11	32.9	27	220.6	12	37.0	28	248.5	13	41.7	29	279.9	14	47.0	30	315.3	15	52.9	31	355.1	16	Middle response ↓	59.6	32	High response ↓	400.0	12	PA09	<p>Auto tuning response</p> <p>Set a response of the auto tuning.</p> <table border="1"> <thead> <tr> <th rowspan="2">Setting value</th> <th colspan="2">Machine characteristic</th> <th rowspan="2">Setting value</th> <th colspan="2">Machine characteristic</th> </tr> <tr> <th>Response</th> <th>Guideline for machine resonance frequency [Hz]</th> <th>Response</th> <th>Guideline for machine resonance frequency [Hz]</th> </tr> </thead> <tbody> <tr><td>1</td><td rowspan="20">Low response ↑</td><td>2.7</td><td>21</td><td rowspan="20">Middle response ↑</td><td>67.1</td></tr> <tr><td>2</td><td>3.6</td><td>22</td><td>75.6</td></tr> <tr><td>3</td><td>4.9</td><td>23</td><td>85.2</td></tr> <tr><td>4</td><td>6.6</td><td>24</td><td>95.9</td></tr> <tr><td>5</td><td>10.0</td><td>25</td><td>108.0</td></tr> <tr><td>6</td><td>11.3</td><td>26</td><td>121.7</td></tr> <tr><td>7</td><td>12.7</td><td>27</td><td>137.1</td></tr> <tr><td>8</td><td>14.3</td><td>28</td><td>154.4</td></tr> <tr><td>9</td><td>16.1</td><td>29</td><td>173.9</td></tr> <tr><td>10</td><td>18.1</td><td>30</td><td>195.9</td></tr> <tr><td>11</td><td>20.4</td><td>31</td><td>220.6</td></tr> <tr><td>12</td><td>23.0</td><td>32</td><td>248.5</td></tr> <tr><td>13</td><td>25.9</td><td>33</td><td>279.9</td></tr> <tr><td>14</td><td>29.2</td><td>34</td><td>315.3</td></tr> <tr><td>15</td><td>32.9</td><td>35</td><td>355.1</td></tr> <tr><td>16</td><td>37.0</td><td>36</td><td>400.0</td></tr> <tr><td>17</td><td>41.7</td><td>37</td><td>446.6</td></tr> <tr><td>18</td><td>47.0</td><td>38</td><td>501.2</td></tr> <tr><td>19</td><td>52.9</td><td>39</td><td>571.5</td></tr> <tr><td>20</td><td>Middle response ↓</td><td>59.6</td><td>40</td><td>High response ↓</td><td>642.7</td></tr> </tbody> </table>	Setting value	Machine characteristic		Setting value	Machine characteristic		Response	Guideline for machine resonance frequency [Hz]	Response	Guideline for machine resonance frequency [Hz]	1	Low response ↑	2.7	21	Middle response ↑	67.1	2	3.6	22	75.6	3	4.9	23	85.2	4	6.6	24	95.9	5	10.0	25	108.0	6	11.3	26	121.7	7	12.7	27	137.1	8	14.3	28	154.4	9	16.1	29	173.9	10	18.1	30	195.9	11	20.4	31	220.6	12	23.0	32	248.5	13	25.9	33	279.9	14	29.2	34	315.3	15	32.9	35	355.1	16	37.0	36	400.0	17	41.7	37	446.6	18	47.0	38	501.2	19	52.9	39	571.5	20	Middle response ↓	59.6	40	High response ↓	642.7	16
	Setting value	Response	Guideline for machine resonance frequency [Hz]	Setting value	Response	Guideline for machine resonance frequency [Hz]																																																																																																																																																																							
1	Low response ↑	10.0	17	Middle response ↑	67.1																																																																																																																																																																								
2		11.3	18		75.6																																																																																																																																																																								
3		12.7	19		85.2																																																																																																																																																																								
4		14.3	20		95.9																																																																																																																																																																								
5		16.1	21		108.0																																																																																																																																																																								
6		18.1	22		121.7																																																																																																																																																																								
7		20.4	23		137.1																																																																																																																																																																								
8		23.0	24		154.4																																																																																																																																																																								
9		25.9	25		173.9																																																																																																																																																																								
10		29.2	26		195.9																																																																																																																																																																								
11		32.9	27		220.6																																																																																																																																																																								
12		37.0	28		248.5																																																																																																																																																																								
13		41.7	29		279.9																																																																																																																																																																								
14		47.0	30		315.3																																																																																																																																																																								
15		52.9	31		355.1																																																																																																																																																																								
16	Middle response ↓	59.6	32	High response ↓	400.0																																																																																																																																																																								
Setting value	Machine characteristic		Setting value	Machine characteristic																																																																																																																																																																									
	Response	Guideline for machine resonance frequency [Hz]		Response	Guideline for machine resonance frequency [Hz]																																																																																																																																																																								
1	Low response ↑	2.7	21	Middle response ↑	67.1																																																																																																																																																																								
2		3.6	22		75.6																																																																																																																																																																								
3		4.9	23		85.2																																																																																																																																																																								
4		6.6	24		95.9																																																																																																																																																																								
5		10.0	25		108.0																																																																																																																																																																								
6		11.3	26		121.7																																																																																																																																																																								
7		12.7	27		137.1																																																																																																																																																																								
8		14.3	28		154.4																																																																																																																																																																								
9		16.1	29		173.9																																																																																																																																																																								
10		18.1	30		195.9																																																																																																																																																																								
11		20.4	31		220.6																																																																																																																																																																								
12		23.0	32		248.5																																																																																																																																																																								
13		25.9	33		279.9																																																																																																																																																																								
14		29.2	34		315.3																																																																																																																																																																								
15		32.9	35		355.1																																																																																																																																																																								
16		37.0	36		400.0																																																																																																																																																																								
17		41.7	37		446.6																																																																																																																																																																								
18		47.0	38		501.2																																																																																																																																																																								
19		52.9	39		571.5																																																																																																																																																																								
20		Middle response ↓	59.6		40	High response ↓	642.7																																																																																																																																																																						

Part 4: Replacement of MR-J3W-_B with MR-J4W2-_B

MR-J3W-_B			MR-J4W2-_B																								
No.	Name and function	Initial value	No.	Name and function	Initial value																						
PA10	<p>In-position range</p> <p>This parameter cannot be used in the speed control mode and the torque control mode.</p> <p>Set the range, where in-position (INP-A/INP-B) is output, in the command pulse unit.</p>	100	PA10	<p>In-position range</p> <p>Set an in-position range per command pulse.</p>	1600																						
PA14	<p>Rotation direction selection</p> <p>Turn off the power and then on again, or reset the controller after setting the parameter to validate the parameter value.</p> <p>Select servo motor rotation direction relative.</p> <table border="1" style="width: 100%; border-collapse: collapse;"> <thead> <tr> <th rowspan="2">[Pr. PA14] setting</th> <th colspan="2">Servo motor rotation direction (Note)</th> </tr> <tr> <th>When positioning address increases (Position control) Command speed in the positive direction (Speed control) Command torque in the positive direction (Torque control)</th> <th>When positioning address decreases (Position control) Command speed in the negative direction (Speed control) Command torque in the negative direction (Torque control)</th> </tr> </thead> <tbody> <tr> <td>0</td> <td>CCW</td> <td>CW</td> </tr> <tr> <td>1</td> <td>CW</td> <td>CCW</td> </tr> </tbody> </table> <p>Note. Torque generation direction for the torque control</p>	[Pr. PA14] setting	Servo motor rotation direction (Note)		When positioning address increases (Position control) Command speed in the positive direction (Speed control) Command torque in the positive direction (Torque control)	When positioning address decreases (Position control) Command speed in the negative direction (Speed control) Command torque in the negative direction (Torque control)	0	CCW	CW	1	CW	CCW	0	PA14	<p>Rotation direction selection/travel direction selection</p> <p>Select a rotation direction or travel direction.</p> <table border="1" style="width: 100%; border-collapse: collapse;"> <thead> <tr> <th rowspan="2">Setting value</th> <th colspan="2">Servo motor rotation direction</th> </tr> <tr> <th>Positioning address increase</th> <th>Positioning address decrease</th> </tr> </thead> <tbody> <tr> <td>0</td> <td>CCW or positive direction</td> <td>CW or negative direction</td> </tr> <tr> <td>1</td> <td>CW or negative direction</td> <td>CCW or positive direction</td> </tr> </tbody> </table> <p>The following shows the servo motor rotation directions.</p>	Setting value	Servo motor rotation direction		Positioning address increase	Positioning address decrease	0	CCW or positive direction	CW or negative direction	1	CW or negative direction	CCW or positive direction	0
[Pr. PA14] setting	Servo motor rotation direction (Note)																										
	When positioning address increases (Position control) Command speed in the positive direction (Speed control) Command torque in the positive direction (Torque control)	When positioning address decreases (Position control) Command speed in the negative direction (Speed control) Command torque in the negative direction (Torque control)																									
0	CCW	CW																									
1	CW	CCW																									
Setting value	Servo motor rotation direction																										
	Positioning address increase	Positioning address decrease																									
0	CCW or positive direction	CW or negative direction																									
1	CW or negative direction	CCW or positive direction																									

Part 4: Replacement of MR-J3W-_B with MR-J4W2-_B

MR-J3W-_B			MR-J4W2-_B		
No.	Name and function	Initial value	No.	Name and function	Initial value
PA15	<p>Encoder output pulses</p> <p>Encoder output pulses 2</p> <p>Turn off the power and then on again, or reset the controller after setting the parameter to validate the parameter value.</p> <p>Used to set the encoder pulses (A/B-phase) output by the servo amplifier.</p> <p>Set the value 4 times greater than the A-phase or B-phase pulses.</p> <p>You can use [Pr. PC03] to choose the output pulse setting or output division ratio setting.</p> <p>The number of A/B-phase pulses actually output is 1/4 times greater than the preset number of pulses.</p> <p>The maximum output frequency is 4.6 Mpulses/s (after multiplication by 4). Use this parameter within this range.</p> <p>(1) For output pulse designation Set " __ 0_" in [Pr. PC03]. Set the number of pulses per servo motor revolution. Output pulse = set value [pulse/rev] For instance, set "5600" to [Pr. PA15], the actually output A/B-phase pulses are as indicated below. A/B-phase output pulses = $\frac{5600}{4} = 1400$ pulses</p> <p>(2) For output division ratio setting Set " __ 1_" in [Pr. PC03]. The number of pulses per servo motor revolution is divided by the set value. $\text{output pulse} = \frac{\text{Resolution per servo motor revolution}}{\text{Set value}} \text{ [pulse/rev]}$ For instance, set "8" to [Pr. PA15], the actually output A/B-phase pulses are as indicated below. A/B-phase output pulses = $\frac{262144}{8} \cdot \frac{1}{4} = 8192$ pulses</p>	4000	PA15	<p>Encoder output pulses</p> <p>Set the encoder output pulses from the servo amplifier by using the number of output pulses per revolution, dividing ratio, or electronic gear ratio. (after multiplication by 4)</p> <p>Set a numerator of the electronic gear, for when selecting "A-phase/B-phase pulse electronic gear setting (__ 3 _)" of "Encoder output pulse setting selection" in [Pr. PC03].</p> <p>The maximum output frequency is 4.6 Mpulses/s. Set the parameter within this range.</p>	4000
PA16	<p>(3) A/B-phase pulse electronic gear setting</p> <p>This parameter is made valid when [Pr. PC03] is set to " __ 3_".</p> <p>Set the encoder pulses (A/B-phase) output by the servo amplifier.</p> <p>Set the encoder pulses output by the servo amplifier by [Pr. PA15] and [Pr. PA16].</p> <p>Travel distance [pulse] of the linear encoder is multiplied by the set value.</p> $\text{output pulse} = \text{Travel distance of linear encoder} \times \frac{[\text{Pr. PA15}]}{[\text{Pr. PA16}]} \text{ [pulse]}$ <p>The number of A/B-phase pulses actually output is 1/4 times greater than the preset number of pulses. Also, the maximum output frequency is 4.6 Mpulses/s (after multiplication by 4). Use this parameter within the range.</p> <p>When the set value is "0 (factory setting)", it is internally treated as "1".</p>	0	PA16	<p>Encoder output pulses 2</p> <p>Set a denominator of the electronic gear for the A/B-phase pulse output. Set a denominator of the electronic gear, for when selecting "A-phase/B-phase pulse electronic gear setting (__ 3 _)" of "Encoder output pulse setting selection" in [Pr. PC03].</p>	1

Part 4: Replacement of MR-J3W-_B with MR-J4W2-_B

MR-J3W-_B				MR-J4W2-_B																																																																																																																																																																																																																																																																																																																																																																					
No.	Name and function	Initial value	No.	Name and function	Initial value																																																																																																																																																																																																																																																																																																																																																																				
PA19	<p>Parameter write inhibit</p> <p>Turn off the power and then on again, or reset the controller after setting the parameter to validate the parameter value. In the factory setting, this servo amplifier allows changes to the basic setting parameter, gain/filter parameter and extension setting parameter settings. With the setting of [Pr. PA19], write can be disabled to prevent accidental changes.</p> <p>The following table indicates the parameters which are enabled for reference and write by the setting of [Pr. PA19]. Operation can be performed for the parameters marked ○.</p> <table border="1" style="width: 100%; border-collapse: collapse; text-align: center;"> <thead> <tr> <th>[Pr. PA19] setting</th> <th>Setting operation</th> <th>Basic setting [Pr. PA_]</th> <th>Gain/filter [Pr. PB_]</th> <th>Extension setting [Pr. PC_]</th> <th>I/O setting [Pr. PD_]</th> <th>Special setting [Pr. PS_] (Note)</th> <th>Option setting [Pr. Po_]</th> </tr> </thead> <tbody> <tr> <td rowspan="2">0000h</td> <td>Reference</td> <td>○</td> <td>/</td> <td>/</td> <td>/</td> <td>/</td> <td>/</td> </tr> <tr> <td>Write</td> <td>○</td> <td>/</td> <td>/</td> <td>/</td> <td>/</td> <td>/</td> </tr> <tr> <td rowspan="2">000Bh (factory setting)</td> <td>Reference</td> <td>○</td> <td>○</td> <td>○</td> <td>/</td> <td>/</td> <td>/</td> </tr> <tr> <td>Write</td> <td>○</td> <td>○</td> <td>○</td> <td>/</td> <td>/</td> <td>/</td> </tr> <tr> <td rowspan="2">000Ch</td> <td>Reference</td> <td>○</td> <td>○</td> <td>○</td> <td>○</td> <td>/</td> <td>/</td> </tr> <tr> <td>Write</td> <td>○</td> <td>○</td> <td>○</td> <td>○</td> <td>/</td> <td>/</td> </tr> <tr> <td rowspan="2">000Dh</td> <td>Reference</td> <td>○</td> <td>○</td> <td>○</td> <td>○</td> <td>○</td> <td>/</td> </tr> <tr> <td>Write</td> <td>○</td> <td>○</td> <td>○</td> <td>○</td> <td>○</td> <td>/</td> </tr> <tr> <td rowspan="2">000Eh</td> <td>Reference</td> <td>○</td> <td>○</td> <td>○</td> <td>○</td> <td>○</td> <td>○</td> </tr> <tr> <td>Write</td> <td>○</td> <td>○</td> <td>○</td> <td>○</td> <td>○</td> <td>○</td> </tr> <tr> <td rowspan="2">100Bh</td> <td>Reference</td> <td>○</td> <td>/</td> <td>/</td> <td>/</td> <td>/</td> <td>/</td> </tr> <tr> <td>Write</td> <td>[Pr. PA19] only</td> <td>/</td> <td>/</td> <td>/</td> <td>/</td> <td>/</td> </tr> <tr> <td rowspan="2">100Ch</td> <td>Reference</td> <td>○</td> <td>○</td> <td>○</td> <td>○</td> <td>/</td> <td>/</td> </tr> <tr> <td>Write</td> <td>[Pr. PA19] only</td> <td>/</td> <td>/</td> <td>/</td> <td>/</td> <td>/</td> </tr> <tr> <td rowspan="2">100Dh</td> <td>Reference</td> <td>○</td> <td>○</td> <td>○</td> <td>○</td> <td>○</td> <td>/</td> </tr> <tr> <td>Write</td> <td>[Pr. PA19] only</td> <td>/</td> <td>/</td> <td>/</td> <td>/</td> <td>/</td> </tr> <tr> <td rowspan="2">100Eh</td> <td>Reference</td> <td>○</td> <td>○</td> <td>○</td> <td>○</td> <td>○</td> <td>○</td> </tr> <tr> <td>Write</td> <td>[Pr. PA19] only</td> <td>/</td> <td>/</td> <td>/</td> <td>/</td> <td>/</td> </tr> </tbody> </table> <p>Note. Do not use this parameter when using a rotary servo motor.</p>	[Pr. PA19] setting	Setting operation	Basic setting [Pr. PA_]	Gain/filter [Pr. PB_]	Extension setting [Pr. PC_]	I/O setting [Pr. PD_]	Special setting [Pr. PS_] (Note)	Option setting [Pr. Po_]	0000h	Reference	○	/	/	/	/	/	Write	○	/	/	/	/	/	000Bh (factory setting)	Reference	○	○	○	/	/	/	Write	○	○	○	/	/	/	000Ch	Reference	○	○	○	○	/	/	Write	○	○	○	○	/	/	000Dh	Reference	○	○	○	○	○	/	Write	○	○	○	○	○	/	000Eh	Reference	○	○	○	○	○	○	Write	○	○	○	○	○	○	100Bh	Reference	○	/	/	/	/	/	Write	[Pr. PA19] only	/	/	/	/	/	100Ch	Reference	○	○	○	○	/	/	Write	[Pr. PA19] only	/	/	/	/	/	100Dh	Reference	○	○	○	○	○	/	Write	[Pr. PA19] only	/	/	/	/	/	100Eh	Reference	○	○	○	○	○	○	Write	[Pr. PA19] only	/	/	/	/	/	000Bh	PA19	<p>Parameter writing inhibit</p> <p>Select a reference range and writing range of the parameter.</p> <p>Refer to the following table for settings.</p> <p>Setting parameters ([Pr. PL_]) cannot be used with MR-J4W2-0303B6 servo amplifiers.</p> <p>[Pr. PA19] setting value and reading/writing range</p> <table border="1" style="width: 100%; border-collapse: collapse; text-align: center;"> <thead> <tr> <th>PA19</th> <th>Setting operation</th> <th>PA</th> <th>PB</th> <th>PC</th> <th>PD</th> <th>PE</th> <th>PF</th> <th>PL</th> </tr> </thead> <tbody> <tr> <td rowspan="2">Other than below</td> <td>Reading</td> <td>○</td> <td>/</td> <td>/</td> <td>/</td> <td>/</td> <td>/</td> <td>/</td> </tr> <tr> <td>Writing</td> <td>○</td> <td>/</td> <td>/</td> <td>/</td> <td>/</td> <td>/</td> <td>/</td> </tr> <tr> <td rowspan="2">000Ah</td> <td>Reading</td> <td>Only 19</td> <td>/</td> <td>/</td> <td>/</td> <td>/</td> <td>/</td> <td>/</td> </tr> <tr> <td>Writing</td> <td>Only 19</td> <td>/</td> <td>/</td> <td>/</td> <td>/</td> <td>/</td> <td>/</td> </tr> <tr> <td rowspan="2">000Bh</td> <td>Reading</td> <td>○</td> <td>○</td> <td>○</td> <td>/</td> <td>/</td> <td>/</td> <td>/</td> </tr> <tr> <td>Writing</td> <td>○</td> <td>○</td> <td>○</td> <td>/</td> <td>/</td> <td>/</td> <td>/</td> </tr> <tr> <td rowspan="2">000Ch</td> <td>Reading</td> <td>○</td> <td>○</td> <td>○</td> <td>○</td> <td>/</td> <td>/</td> <td>/</td> </tr> <tr> <td>Writing</td> <td>○</td> <td>○</td> <td>○</td> <td>○</td> <td>/</td> <td>/</td> <td>/</td> </tr> <tr> <td rowspan="2">000Fh</td> <td>Reading</td> <td>○</td> <td>○</td> <td>○</td> <td>○</td> <td>○</td> <td>/</td> <td>○</td> </tr> <tr> <td>Writing</td> <td>○</td> <td>○</td> <td>○</td> <td>○</td> <td>○</td> <td>/</td> <td>○</td> </tr> <tr> <td rowspan="2">00AAh</td> <td>Reading</td> <td>○</td> <td>○</td> <td>○</td> <td>○</td> <td>○</td> <td>○</td> <td>/</td> </tr> <tr> <td>Writing</td> <td>○</td> <td>○</td> <td>○</td> <td>○</td> <td>○</td> <td>○</td> <td>/</td> </tr> <tr> <td rowspan="2">00ABh (initial value)</td> <td>Reading</td> <td>○</td> <td>○</td> <td>○</td> <td>○</td> <td>○</td> <td>○</td> <td>○</td> </tr> <tr> <td>Writing</td> <td>○</td> <td>○</td> <td>○</td> <td>○</td> <td>○</td> <td>○</td> <td>○</td> </tr> <tr> <td rowspan="2">100Bh</td> <td>Reading</td> <td>○</td> <td>/</td> <td>/</td> <td>/</td> <td>/</td> <td>/</td> <td>/</td> </tr> <tr> <td>Writing</td> <td>Only 19</td> <td>/</td> <td>/</td> <td>/</td> <td>/</td> <td>/</td> <td>/</td> </tr> <tr> <td rowspan="2">100Ch</td> <td>Reading</td> <td>○</td> <td>○</td> <td>○</td> <td>○</td> <td>/</td> <td>/</td> <td>/</td> </tr> <tr> <td>Writing</td> <td>Only 19</td> <td>/</td> <td>/</td> <td>/</td> <td>/</td> <td>/</td> <td>/</td> </tr> <tr> <td rowspan="2">100Fh</td> <td>Reading</td> <td>○</td> <td>○</td> <td>○</td> <td>○</td> <td>○</td> <td>/</td> <td>○</td> </tr> <tr> <td>Writing</td> <td>Only 19</td> <td>/</td> <td>/</td> <td>/</td> <td>/</td> <td>/</td> <td>/</td> </tr> <tr> <td rowspan="2">10AAh</td> <td>Reading</td> <td>○</td> <td>○</td> <td>○</td> <td>○</td> <td>○</td> <td>○</td> <td>/</td> </tr> <tr> <td>Writing</td> <td>Only 19</td> <td>/</td> <td>/</td> <td>/</td> <td>/</td> <td>/</td> <td>/</td> </tr> <tr> <td rowspan="2">10ABh</td> <td>Reading</td> <td>○</td> <td>○</td> <td>○</td> <td>○</td> <td>○</td> <td>○</td> <td>○</td> </tr> <tr> <td>Writing</td> <td>Only 19</td> <td>/</td> <td>/</td> <td>/</td> <td>/</td> <td>/</td> <td>/</td> </tr> </tbody> </table>	PA19	Setting operation	PA	PB	PC	PD	PE	PF	PL	Other than below	Reading	○	/	/	/	/	/	/	Writing	○	/	/	/	/	/	/	000Ah	Reading	Only 19	/	/	/	/	/	/	Writing	Only 19	/	/	/	/	/	/	000Bh	Reading	○	○	○	/	/	/	/	Writing	○	○	○	/	/	/	/	000Ch	Reading	○	○	○	○	/	/	/	Writing	○	○	○	○	/	/	/	000Fh	Reading	○	○	○	○	○	/	○	Writing	○	○	○	○	○	/	○	00AAh	Reading	○	○	○	○	○	○	/	Writing	○	○	○	○	○	○	/	00ABh (initial value)	Reading	○	○	○	○	○	○	○	Writing	○	○	○	○	○	○	○	100Bh	Reading	○	/	/	/	/	/	/	Writing	Only 19	/	/	/	/	/	/	100Ch	Reading	○	○	○	○	/	/	/	Writing	Only 19	/	/	/	/	/	/	100Fh	Reading	○	○	○	○	○	/	○	Writing	Only 19	/	/	/	/	/	/	10AAh	Reading	○	○	○	○	○	○	/	Writing	Only 19	/	/	/	/	/	/	10ABh	Reading	○	○	○	○	○	○	○	Writing	Only 19	/	/	/	/	/	/	00ABh
[Pr. PA19] setting	Setting operation	Basic setting [Pr. PA_]	Gain/filter [Pr. PB_]	Extension setting [Pr. PC_]	I/O setting [Pr. PD_]	Special setting [Pr. PS_] (Note)	Option setting [Pr. Po_]																																																																																																																																																																																																																																																																																																																																																																		
0000h	Reference	○	/	/	/	/	/																																																																																																																																																																																																																																																																																																																																																																		
	Write	○	/	/	/	/	/																																																																																																																																																																																																																																																																																																																																																																		
000Bh (factory setting)	Reference	○	○	○	/	/	/																																																																																																																																																																																																																																																																																																																																																																		
	Write	○	○	○	/	/	/																																																																																																																																																																																																																																																																																																																																																																		
000Ch	Reference	○	○	○	○	/	/																																																																																																																																																																																																																																																																																																																																																																		
	Write	○	○	○	○	/	/																																																																																																																																																																																																																																																																																																																																																																		
000Dh	Reference	○	○	○	○	○	/																																																																																																																																																																																																																																																																																																																																																																		
	Write	○	○	○	○	○	/																																																																																																																																																																																																																																																																																																																																																																		
000Eh	Reference	○	○	○	○	○	○																																																																																																																																																																																																																																																																																																																																																																		
	Write	○	○	○	○	○	○																																																																																																																																																																																																																																																																																																																																																																		
100Bh	Reference	○	/	/	/	/	/																																																																																																																																																																																																																																																																																																																																																																		
	Write	[Pr. PA19] only	/	/	/	/	/																																																																																																																																																																																																																																																																																																																																																																		
100Ch	Reference	○	○	○	○	/	/																																																																																																																																																																																																																																																																																																																																																																		
	Write	[Pr. PA19] only	/	/	/	/	/																																																																																																																																																																																																																																																																																																																																																																		
100Dh	Reference	○	○	○	○	○	/																																																																																																																																																																																																																																																																																																																																																																		
	Write	[Pr. PA19] only	/	/	/	/	/																																																																																																																																																																																																																																																																																																																																																																		
100Eh	Reference	○	○	○	○	○	○																																																																																																																																																																																																																																																																																																																																																																		
	Write	[Pr. PA19] only	/	/	/	/	/																																																																																																																																																																																																																																																																																																																																																																		
PA19	Setting operation	PA	PB	PC	PD	PE	PF	PL																																																																																																																																																																																																																																																																																																																																																																	
Other than below	Reading	○	/	/	/	/	/	/																																																																																																																																																																																																																																																																																																																																																																	
	Writing	○	/	/	/	/	/	/																																																																																																																																																																																																																																																																																																																																																																	
000Ah	Reading	Only 19	/	/	/	/	/	/																																																																																																																																																																																																																																																																																																																																																																	
	Writing	Only 19	/	/	/	/	/	/																																																																																																																																																																																																																																																																																																																																																																	
000Bh	Reading	○	○	○	/	/	/	/																																																																																																																																																																																																																																																																																																																																																																	
	Writing	○	○	○	/	/	/	/																																																																																																																																																																																																																																																																																																																																																																	
000Ch	Reading	○	○	○	○	/	/	/																																																																																																																																																																																																																																																																																																																																																																	
	Writing	○	○	○	○	/	/	/																																																																																																																																																																																																																																																																																																																																																																	
000Fh	Reading	○	○	○	○	○	/	○																																																																																																																																																																																																																																																																																																																																																																	
	Writing	○	○	○	○	○	/	○																																																																																																																																																																																																																																																																																																																																																																	
00AAh	Reading	○	○	○	○	○	○	/																																																																																																																																																																																																																																																																																																																																																																	
	Writing	○	○	○	○	○	○	/																																																																																																																																																																																																																																																																																																																																																																	
00ABh (initial value)	Reading	○	○	○	○	○	○	○																																																																																																																																																																																																																																																																																																																																																																	
	Writing	○	○	○	○	○	○	○																																																																																																																																																																																																																																																																																																																																																																	
100Bh	Reading	○	/	/	/	/	/	/																																																																																																																																																																																																																																																																																																																																																																	
	Writing	Only 19	/	/	/	/	/	/																																																																																																																																																																																																																																																																																																																																																																	
100Ch	Reading	○	○	○	○	/	/	/																																																																																																																																																																																																																																																																																																																																																																	
	Writing	Only 19	/	/	/	/	/	/																																																																																																																																																																																																																																																																																																																																																																	
100Fh	Reading	○	○	○	○	○	/	○																																																																																																																																																																																																																																																																																																																																																																	
	Writing	Only 19	/	/	/	/	/	/																																																																																																																																																																																																																																																																																																																																																																	
10AAh	Reading	○	○	○	○	○	○	/																																																																																																																																																																																																																																																																																																																																																																	
	Writing	Only 19	/	/	/	/	/	/																																																																																																																																																																																																																																																																																																																																																																	
10ABh	Reading	○	○	○	○	○	○	○																																																																																																																																																																																																																																																																																																																																																																	
	Writing	Only 19	/	/	/	/	/	/																																																																																																																																																																																																																																																																																																																																																																	
PB01	<p>Adaptive tuning mode (Adaptive filter II)</p> <p>Used to set the mode for the machine resonance suppression filter 1.</p> <p>0 0 0 x:</p> <p>Filter tuning mode</p> <p>0: Invalid</p> <p>1: Cannot be set</p> <p>2: Manual setting</p> <p>If " _ _ _ 1" is set for this parameter, it is automatically rewritten as " _ _ _ 0"</p>	0000h	PB01	<p>Adaptive tuning mode (adaptive filter II)</p> <p>Set the adaptive tuning.</p> <p>All axes cannot be simultaneously enabled for this function. Set for each axis to use.</p> <p>_ _ _ x:</p> <p>Filter tuning mode selection</p> <p>Select the adjustment mode of the machine resonance suppression filter 1.</p> <p>0: Disabled</p> <p>1: Automatic setting</p> <p>2: Manual setting</p> <p>_ _ x _:</p> <p>For manufacturer setting</p> <p>_ x _ _:</p> <p>For manufacturer setting</p> <p>x _ _ _:</p> <p>Tuning accuracy selection</p> <p>0: Standard</p> <p>1: High accuracy</p> <p>The frequency is estimated more accurately in the high accuracy mode compared to the standard mode. However, the tuning sound may be larger in the high accuracy mode.</p> <p>This digit is available with servo amplifier with software version C5 or later.</p>	0h																																																																																																																																																																																																																																																																																																																																																																				

Part 4: Replacement of MR-J3W-_B with MR-J4W2-_B

MR-J3W-_B			MR-J4W2-_B						
No.	Name and function	Initial value	No.	Name and function	Initial value				
PB02	<p>Vibration suppression control tuning mode (advanced vibration suppression control)</p> <p>Used to set the tuning mode for the vibration suppression control.</p> <p>0 0 0 x:</p> <p>Vibration suppression control tuning mode</p> <p>0: Invalid</p> <p>1: Cannot be set</p> <p>2: Manual setting</p> <p>If "___1" is set for this parameter, it is automatically rewritten as "___0".</p>	0000h	PB02	<p>Vibration suppression control tuning mode (advanced vibration suppression control II)</p> <p>This is used to set the vibration suppression control tuning.</p> <p>All axes cannot be simultaneously enabled for this function. Set for each axis to use.</p>					
			<p>___ x:</p> <p>Vibration suppression control 1 tuning mode selection</p> <p>Select the tuning mode of the vibration suppression control 1.</p> <p>0: Disabled</p> <p>1: Automatic setting</p> <p>2: Manual setting</p>	0h					
			<p>__ x _:</p> <p>Vibration suppression control 2 tuning mode selection</p> <p>Select the tuning mode of the vibration suppression control 2. To enable the digit, select "3 inertia mode (___1)" of "Vibration suppression mode selection" in [Pr. PA24 Function selection A-4].</p> <p>0: Disabled</p> <p>1: Automatic setting</p> <p>2: Manual setting</p>	0h					
			<p>_ x _:</p> <p>For manufacturer setting</p>	0h					
			<p>x _ _:</p> <p>For manufacturer setting</p>	0h					
PB03	This parameter is not used. Do not change the value.	0	PB03	<p>Torque feedback loop gain</p> <p>Set a torque feedback loop gain in the continuous operation to torque control mode.</p> <p>Decreasing the setting value will also decrease a collision load during continuous operation to torque control mode.</p> <p>Setting a value less than 6 rad/s will be 6 rad/s.</p>	18000				
PB04	<p>Feed forward gain</p> <p>This parameter cannot be used in the speed control mode.</p> <p>Set the feed forward gain. When the setting is 100%, the droop pulses during operation at constant speed are nearly zero. However, sudden acceleration/deceleration will increase the overshoot. As a guideline, when the feed forward gain setting is 100%, set 1 s or more as the acceleration time constant up to the rated speed.</p>	0	PB04	<p>Feed forward gain</p> <p>Set the feed forward gain.</p> <p>When the setting is 100%, the droop pulses during operation at constant speed are nearly zero. However, sudden acceleration/deceleration will increase the overshoot. As a guideline, when the feed forward gain setting is 100%, set 1 s or more as the acceleration time constant up to the rated speed.</p>	0				
PB06	<p>Load to motor inertia moment ratio</p> <p>Used to set the ratio of the load inertia moment to the servo motor shaft inertia moment. When auto tuning mode 1 and interpolation mode is selected, the result of auto tuning is automatically used.</p> <p>In this case, it varies between 0 and 100.0.</p> <p>When [Pr. PA08] is set to "___2" or "___3", this parameter can be set manually.</p>	7.0	PB06	<p>Load to motor inertia ratio/load to motor mass ratio</p> <p>Set a load to motor inertia ratio or load to motor mass ratio. Setting a value considerably different from the actual load moment of inertia or load mass may cause an unexpected operation such as an overshoot.</p> <p>The setting of the parameter will be the automatic setting or manual setting depending on the [Pr. PA08] setting. Refer to the following table for details. When the parameter is automatic setting, the value will vary between 0.00 and 100.00.</p>	7.00				
				<table border="1"> <thead> <tr> <th>Pr. PA08</th> <th>This parameter</th> </tr> </thead> <tbody> <tr> <td>___0 (2 gain adjustment mode 1 (interpolation mode))</td> <td rowspan="2">Automatic setting</td> </tr> <tr> <td>___1 (Auto tuning mode 1)</td> </tr> <tr> <td>___2 (Auto tuning mode 2)</td> <td rowspan="3">Manual setting</td> </tr> <tr> <td>___3 (Manual mode)</td> </tr> <tr> <td>___4 (2 gain adjustment mode 2)</td> </tr> </tbody> </table>		Pr. PA08	This parameter	___0 (2 gain adjustment mode 1 (interpolation mode))	Automatic setting
Pr. PA08	This parameter								
___0 (2 gain adjustment mode 1 (interpolation mode))	Automatic setting								
___1 (Auto tuning mode 1)									
___2 (Auto tuning mode 2)	Manual setting								
___3 (Manual mode)									
___4 (2 gain adjustment mode 2)									

Part 4: Replacement of MR-J3W-_B with MR-J4W2-_B

MR-J3W-_B			MR-J4W2-_B													
No.	Name and function	Initial value	No.	Name and function	Initial value											
PB07	<p>Model loop gain</p> <p>Set the response gain up to the target position.</p> <p>Increase the gain to improve track ability in response to the command.</p> <p>When auto turning mode 1, 2 is selected, the result of auto turning is automatically used.</p> <p>When [Pr. PA08] is set to "___0" or "___3", this parameter can be set manually.</p>	24	PB07	<p>Model loop gain</p> <p>Set the response gain up to the target position.</p> <p>Increasing the setting value will also increase the response level to the position command but will be liable to generate vibration and noise.</p> <p>For the vibration suppression control tuning mode, the setting range of [Pr. PB07] is limited. Refer to "MR-J4W2-_B/MR-J4W3-_B/MR-J4W2-0303B6 Servo Amplifier Instruction Manual" for details.</p> <p>The setting of the parameter will be the automatic setting or manual setting depending on the [Pr. PA08] setting. Refer to the following table for details.</p> <table border="1"> <thead> <tr> <th>Pr. PA08</th> <th>This parameter</th> </tr> </thead> <tbody> <tr> <td>___0 (2 gain adjustment mode 1 (interpolation mode))</td> <td>Manual setting</td> </tr> <tr> <td>___1 (Auto tuning mode 1)</td> <td rowspan="2">Automatic setting</td> </tr> <tr> <td>___2 (Auto tuning mode 2)</td> </tr> <tr> <td>___3 (Manual mode)</td> <td>Manual setting</td> </tr> <tr> <td>___4 (2 gain adjustment mode 2)</td> <td>Manual setting</td> </tr> </tbody> </table>	Pr. PA08	This parameter	___0 (2 gain adjustment mode 1 (interpolation mode))	Manual setting	___1 (Auto tuning mode 1)	Automatic setting	___2 (Auto tuning mode 2)	___3 (Manual mode)	Manual setting	___4 (2 gain adjustment mode 2)	Manual setting	15.0
Pr. PA08	This parameter															
___0 (2 gain adjustment mode 1 (interpolation mode))	Manual setting															
___1 (Auto tuning mode 1)	Automatic setting															
___2 (Auto tuning mode 2)																
___3 (Manual mode)	Manual setting															
___4 (2 gain adjustment mode 2)	Manual setting															
PB08	<p>Position loop gain</p> <p>This parameter cannot be used in the speed control mode.</p> <p>Used to set the gain of the position loop.</p> <p>Set this parameter to increase the position response to level load disturbance. Higher setting increases the response level but is liable to generate vibration and/or noise.</p> <p>When auto tuning mode 1, 2 and interpolation mode is selected, the result of auto tuning is automatically used.</p> <p>When [Pr. PA08] is set to "___3", this parameter can be set manually.</p>	37	PB08	<p>Position loop gain</p> <p>Set a gain of the position loop.</p> <p>Set this parameter to increase the position response to level load disturbance.</p> <p>Increasing the setting value will also increase the response level to the load disturbance but will be liable to generate vibration and noise.</p> <p>The setting of the parameter will be the automatic setting or manual setting depending on the [Pr. PA08] setting. Refer to the following table for details.</p> <table border="1"> <thead> <tr> <th>Pr. PA08</th> <th>This parameter</th> </tr> </thead> <tbody> <tr> <td>___0 (2 gain adjustment mode 1 (interpolation mode))</td> <td rowspan="3">Automatic setting</td> </tr> <tr> <td>___1 (Auto tuning mode 1)</td> </tr> <tr> <td>___2 (Auto tuning mode 2)</td> </tr> <tr> <td>___3 (Manual mode)</td> <td>Manual setting</td> </tr> <tr> <td>___4 (2 gain adjustment mode 2)</td> <td>Automatic setting</td> </tr> </tbody> </table>	Pr. PA08	This parameter	___0 (2 gain adjustment mode 1 (interpolation mode))	Automatic setting	___1 (Auto tuning mode 1)	___2 (Auto tuning mode 2)	___3 (Manual mode)	Manual setting	___4 (2 gain adjustment mode 2)	Automatic setting	37.0	
Pr. PA08	This parameter															
___0 (2 gain adjustment mode 1 (interpolation mode))	Automatic setting															
___1 (Auto tuning mode 1)																
___2 (Auto tuning mode 2)																
___3 (Manual mode)	Manual setting															
___4 (2 gain adjustment mode 2)	Automatic setting															
PB09	<p>Speed loop gain</p> <p>Set this parameter when vibration occurs on machines of low rigidity or large backlash.</p> <p>Higher setting increases the response level but is liable to generate vibration and/or noise.</p> <p>When auto tuning mode 1, 2 and interpolation mode is selected, the result of auto tuning is automatically used.</p> <p>When [Pr. PA08] is set to "___3", this parameter can be set manually.</p>	823	PB09	<p>Speed loop gain</p> <p>Set a gain of the speed loop.</p> <p>Set this parameter when vibration occurs on machines of low rigidity or large backlash. Increasing the setting value will also increase the response level but will be liable to generate vibration and noise.</p> <p>The setting of the parameter will be the automatic setting or manual setting depending on the [Pr. PA08] setting. Refer to the table of [Pr. PB08] for details.</p>	823											
PB10	<p>Speed integral compensation</p> <p>Used to set the integral time constant of the speed loop.</p> <p>Lower setting increases the response level but is liable to generate vibration and/or noise.</p> <p>When auto tuning mode 1, 2 and interpolation mode is selected, the result of auto tuning is automatically used.</p> <p>When [Pr. PA08] is set to "___3", this parameter can be set manually.</p>	33.7	PB10	<p>Speed integral compensation</p> <p>Set an integral time constant of the speed loop.</p> <p>Decreasing the setting value will increase the response level but will be liable to generate vibration and noise.</p> <p>The setting of the parameter will be the automatic setting or manual setting depending on the [Pr. PA08] setting. Refer to the table of [Pr. PB08] for details.</p>	33.7											
PB11	<p>Speed differential compensation</p> <p>Used to set the differential compensation.</p> <p>When [Pr. PB24] is set to "___3_", this parameter is made valid. When [Pr. PB24] is set to "___0_", this parameter is made valid by instructions of controller.</p>	980	PB11	<p>Speed differential compensation</p> <p>Set a differential compensation.</p> <p>To enable the parameter, select "Continuous PID control enabled (___3_)" of "PI-PID switching control selection" in [Pr. PB24].</p>	980											

Part 4: Replacement of MR-J3W-_B with MR-J4W2-_B

MR-J3W-_B			MR-J4W2-_B		
No.	Name and function	Initial value	No.	Name and function	Initial value
PB12	This parameter is not used. Do not change the value.		PB12	Overshoot amount compensation Set a dynamic friction torque to rated torque in percentage unit at servo motor rated speed. When the response level is low or when the torque is limited, the efficiency of the parameter may be lower.	0
PB13	Machine resonance suppression filter 1 Set the notch frequency of the machine resonance suppression filter 1. When the [Pr. PB01] setting is "___ 0", the setting of this parameter is ignored. If a value exceeding "3000" is set for this parameter, it is automatically rewritten as "3000".	4500	PB13	Machine resonance suppression filter 1 Set the notch frequency of the machine resonance suppression filter 1. When "Filter tuning mode selection" is set to "Automatic setting (___ 1)" in [Pr. PB01], this parameter will be adjusted automatically by adaptive tuning. When "Filter tuning mode selection" is set to "Manual setting (___ 2)" in [Pr. PB01], the setting value will be enabled.	4500
PB14	Notch shape selection 1 Select the shape of the machine resonance suppression filter 1. 0 _ x 0: Notch depth selection 0: -40 dB 1: -14 dB 2: -8 dB 3: -4 dB 0 x _ 0: Notch width 0: $\alpha = 2$ 1: $\alpha = 3$ 2: $\alpha = 4$ 3: $\alpha = 5$ When the [Pr. PB01] setting is "___ 0", the setting of this parameter is ignored.	0000h	PB14	Notch shape selection 1 Set the shape of the machine resonance suppression filter 1. When "Filter tuning mode selection" is set to "Automatic setting (___ 1)" in [Pr. PB01], this parameter will be adjusted automatically by adaptive tuning. To enable the setting value, select the manual setting.	
			___ x:	For manufacturer setting	0h
			_ _ x _:	Notch depth selection 0: -40 dB 1: -14 dB 2: -8 dB 3: -4 dB	0h
			_ x _:	Notch width selection 0: $\alpha = 2$ 1: $\alpha = 3$ 2: $\alpha = 4$ 3: $\alpha = 5$	0h
PB15	Machine resonance suppression filter 2 Set the notch frequency of the machine resonance suppression filter 2. Set [Pr. PB16] (notch shape selection 2) to "___ 1" to make this parameter valid. If a value exceeding "3000" is set for this parameter, it is automatically rewritten as "3000".	4500	PB15	Machine resonance suppression filter 2 Set the notch frequency of the machine resonance suppression filter 2. To enable the setting value, select "Enabled (___ 1)" of "Machine resonance suppression filter 2 selection" in [Pr. PB16].	4500
			PB16	Notch shape selection 2 Set the shape of the machine resonance suppression filter 2.	
			___ x:	Machine resonance suppression filter 2 selection 0: Disabled 1: Enabled	0h
			_ _ x _:	Notch depth selection 0: -40 dB 1: -14 dB 2: -8 dB 3: -4 dB	0h
PB16	Notch shape selection 2 Select the shape of the machine resonance suppression filter 2. 0 _ _ x: Machine resonance suppression filter 2 selection 0: Invalid 1: Valid 0 _ x _: Notch depth selection 0: -40 dB 1: -14 dB 2: -8 dB 3: -4 dB 0 x _ _: Notch width 0: $\alpha = 2$ 1: $\alpha = 3$ 2: $\alpha = 4$ 3: $\alpha = 5$	0000h	PB16	Notch shape selection 2 Set the shape of the machine resonance suppression filter 2.	
			___ x:	Machine resonance suppression filter 2 selection 0: Disabled 1: Enabled	0h
			_ _ x _:	Notch depth selection 0: -40 dB 1: -14 dB 2: -8 dB 3: -4 dB	0h
			_ x _:	Notch width selection 0: $\alpha = 2$ 1: $\alpha = 3$ 2: $\alpha = 4$ 3: $\alpha = 5$	0h
			x _ _:	For manufacturer setting	0h

Part 4: Replacement of MR-J3W-_B with MR-J4W2-_B

MR-J3W-_B			MR-J4W2-_B																																																																						
No.	Name and function	Initial value	No.	Name and function	Initial value																																																																				
PB17	Automatic setting parameter The value of this parameter is set according to a set value of [Pr. PB06] (Load to motor inertia moment ratio).		PB17	Shaft resonance suppression filter Set a shaft resonance suppression filter. When you select "Automatic setting (___0)" of "Shaft resonance suppression filter selection" in [Pr. PB23], the value will be calculated automatically from the servo motor you use and load to motor inertia ratio. When "Manual setting (___1)" is selected, the setting written to the parameter is used. When "Shaft resonance suppression filter selection" is "Disabled (___2)" in [Pr. PB23], the setting value of this parameter will be disabled. When you select "Enabled (___1)" of "Machine resonance suppression filter 4 selection" in [Pr. PB49], the shaft resonance suppression filter is not available.																																																																					
			___ x x:	Shaft resonance suppression filter setting frequency selection. This is used for setting the shaft resonance suppression filter. Refer to table 4.3 for settings. Set the value closest to the frequency you need.	00h																																																																				
			_ x __:	Notch depth selection 0: -40 dB 1: -14 dB 2: -8 dB 3: -4 dB	0h																																																																				
			x ___:	For manufacturer setting	0h																																																																				
Table 4.3 Shaft resonance suppression filter setting frequency selection																																																																									
<table border="1" style="width: 100%; border-collapse: collapse;"> <thead> <tr> <th>Setting value</th> <th>Frequency [Hz]</th> <th>Setting value</th> <th>Frequency [Hz]</th> </tr> </thead> <tbody> <tr><td>___00</td><td>Disabled</td><td>___10</td><td>562</td></tr> <tr><td>___01</td><td>Disabled</td><td>___11</td><td>529</td></tr> <tr><td>___02</td><td>4500</td><td>___12</td><td>500</td></tr> <tr><td>___03</td><td>3000</td><td>___13</td><td>473</td></tr> <tr><td>___04</td><td>2250</td><td>___14</td><td>450</td></tr> <tr><td>___05</td><td>1800</td><td>___15</td><td>428</td></tr> <tr><td>___06</td><td>1500</td><td>___16</td><td>409</td></tr> <tr><td>___07</td><td>1285</td><td>___17</td><td>391</td></tr> <tr><td>___08</td><td>1125</td><td>___18</td><td>375</td></tr> <tr><td>___09</td><td>1000</td><td>___19</td><td>360</td></tr> <tr><td>___0A</td><td>900</td><td>___1A</td><td>346</td></tr> <tr><td>___0B</td><td>818</td><td>___1B</td><td>333</td></tr> <tr><td>___0C</td><td>750</td><td>___1C</td><td>321</td></tr> <tr><td>___0D</td><td>692</td><td>___1D</td><td>310</td></tr> <tr><td>___0E</td><td>642</td><td>___1E</td><td>300</td></tr> <tr><td>___0F</td><td>600</td><td>___1F</td><td>290</td></tr> </tbody> </table>						Setting value	Frequency [Hz]	Setting value	Frequency [Hz]	___00	Disabled	___10	562	___01	Disabled	___11	529	___02	4500	___12	500	___03	3000	___13	473	___04	2250	___14	450	___05	1800	___15	428	___06	1500	___16	409	___07	1285	___17	391	___08	1125	___18	375	___09	1000	___19	360	___0A	900	___1A	346	___0B	818	___1B	333	___0C	750	___1C	321	___0D	692	___1D	310	___0E	642	___1E	300	___0F	600	___1F	290
Setting value	Frequency [Hz]	Setting value	Frequency [Hz]																																																																						
___00	Disabled	___10	562																																																																						
___01	Disabled	___11	529																																																																						
___02	4500	___12	500																																																																						
___03	3000	___13	473																																																																						
___04	2250	___14	450																																																																						
___05	1800	___15	428																																																																						
___06	1500	___16	409																																																																						
___07	1285	___17	391																																																																						
___08	1125	___18	375																																																																						
___09	1000	___19	360																																																																						
___0A	900	___1A	346																																																																						
___0B	818	___1B	333																																																																						
___0C	750	___1C	321																																																																						
___0D	692	___1D	310																																																																						
___0E	642	___1E	300																																																																						
___0F	600	___1F	290																																																																						
PB18	Low-pass filter setting Set the low-pass filter. Setting [Pr. PB023] (low-pass filter selection) to "___0_" automatically changes this parameter. When [Pr. PB023] is set to "___1_", this parameter can be set manually.	3141	PB18	Low-pass filter setting Set the low-pass filter. The following shows a relation of a required parameter to this parameter.	3141																																																																				
<table border="1" style="width: 100%; border-collapse: collapse;"> <thead> <tr> <th>[Pr. PB23]</th> <th>[Pr. PB18]</th> </tr> </thead> <tbody> <tr> <td>___0_ (Initial value)</td> <td>Automatic setting</td> </tr> <tr> <td>___1_</td> <td>Setting value enabled</td> </tr> <tr> <td>___2_</td> <td>Setting value disabled</td> </tr> </tbody> </table>						[Pr. PB23]	[Pr. PB18]	___0_ (Initial value)	Automatic setting	___1_	Setting value enabled	___2_	Setting value disabled																																																												
[Pr. PB23]	[Pr. PB18]																																																																								
___0_ (Initial value)	Automatic setting																																																																								
___1_	Setting value enabled																																																																								
___2_	Setting value disabled																																																																								

Part 4: Replacement of MR-J3W-__B with MR-J4W2-__B

MR-J3W-__B			MR-J4W2-__B		
No.	Name and function	Initial value	No.	Name and function	Initial value
PB19	Vibration suppression control vibration frequency setting This parameter cannot be used in the speed control mode. Set the vibration frequency for vibration suppression control to suppress low-frequency machine vibration, such as enclosure vibration. When [Pr. PB02] is set to "___2", this parameter can be set manually.	100.0	PB19	Vibration suppression control 1 - Vibration frequency Set the vibration frequency for vibration suppression control 1 to suppress low-frequency machine vibration. When "Vibration suppression control 1 tuning mode selection" is set to "Automatic setting (___1)" in [Pr. PB02], this parameter will be set automatically. When "Manual setting (___2)" is selected, the setting written to the parameter is used. The setting range of this parameter varies, depending on the value in [Pr. PB07]. If a value out of the range is set, the vibration suppression control will be disabled.	100.0
PB20	Vibration suppression control resonance frequency setting This parameter cannot be used in the speed control mode. Set the resonance frequency for vibration suppression control to suppress low-frequency machine vibration, such as enclosure vibration. When [Pr. PB02] is set to "___2", this parameter can be set manually.	100.0	PB20	Vibration suppression control 1 - Resonance frequency Set the resonance frequency for vibration suppression control 1 to suppress low-frequency machine vibration. When "Vibration suppression control 1 tuning mode selection" is set to "Automatic setting (___1)" in [Pr. PB02], this parameter will be set automatically. When "Manual setting (___2)" is selected, the setting written to the parameter is used. The setting range of this parameter varies, depending on the value in [Pr. PB07]. If a value out of the range is set, the vibration suppression control will be disabled.	100.0
PB21	This parameter is not used. Do not change the value.	0.00	PB21	Vibration suppression control 1 - Vibration frequency damping Set a damping of the vibration frequency for vibration suppression control 1 to suppress low-frequency machine vibration. When "Vibration suppression control 1 tuning mode selection" is set to "Automatic setting (___1)" in [Pr. PB02], this parameter will be set automatically. When "Manual setting (___2)" is selected, the setting written to the parameter is used.	0.00
PB22	This parameter is not used. Do not change the value.	0.00	PB22	Vibration suppression control 1 - Resonance frequency damping Set a damping of the resonance frequency for vibration suppression control 1 to suppress low-frequency machine vibration. When "Vibration suppression control 1 tuning mode selection" is set to "Automatic setting (___1)" in [Pr. PB02], this parameter will be set automatically. When "Manual setting (___2)" is selected, the setting written to the parameter is used.	0.00
PB23	Low-pass filter selection Select the low-pass filter. 0 0 x 0: Low-pass filter selection 0: Automatic setting 1: Manual setting ([Pr. PB18] setting) When automatic setting has been selected, select the filter that has the band width close to the one calculated with $\frac{VG2 \cdot 10}{1 + GD2}$ [rad/s]	0000h	PB23	Low-pass filter selection Select the shaft resonance suppression filter and low-pass filter.	
			___x:	Shaft resonance suppression filter selection 0: Automatic setting 1: Manual setting 2: Disabled When you select "Enabled (___1)" of "Machine resonance suppression filter 4 selection" in [Pr. PB49], the shaft resonance suppression filter is not available.	0h
			__x_:	Low-pass filter selection 0: Automatic setting 1: Manual setting 2: Disabled	0h
			_x__:	For manufacturer setting	0h
			x___:	For manufacturer setting	0h

Part 4: Replacement of MR-J3W-_B with MR-J4W2-_B

MR-J3W-_B			MR-J4W2-_B		
No.	Name and function	Initial value	No.	Name and function	Initial value
PB24	<p>Slight vibration suppression control selection</p> <p>Select the slight vibration suppression control and PI-PID change.</p> <p>When [Pr. PA08] (Auto tuning mode) is set to "___3", the slight vibration suppression control is enabled. (Slight vibration suppression control cannot be used in the speed control mode.)</p> <p>0 0 _ x:</p> <p>Slight vibration suppression control selection</p> <p>0: Invalid</p> <p>1: Valid</p>	0000h	PB24	<p>Slight vibration suppression control</p> <p>Select the slight vibration suppression control and PI-PID switching control.</p>	
	<p>0 0 x _:</p> <p>PI-PID control switch over selection</p> <p>0: PI control is valid. (Switching to PID control is possible with instructions of controller.)</p> <p>3: PID control is always valid.</p>			<p>___ x:</p> <p>Slight vibration suppression control selection</p> <p>0: Disabled</p> <p>1: Enabled</p> <p>To enable the slight vibration suppression control, select "Manual mode (___3)" of "Gain adjustment mode selection" in [Pr. PA08]. Slight vibration suppression control cannot be used in the speed control mode.</p>	0h
PB25	This parameter is not used. Do not change the value.	0000h	PB25	<p>___ x _:</p> <p>PI-PID switching control selection</p> <p>0: PI control enabled</p> <p>(Switching to PID control is possible with commands of servo system controller.)</p> <p>3: Continuous PID control enabled</p> <p>If the servo motor at a stop is rotated even for a pulse due to any external factor, it generates torque to compensate for a position shift. When the servo motor shaft is to be locked mechanically after positioning completion (stop), enabling PID control and completing positioning simultaneously will suppress the unnecessary torque generated to compensate for a position shift.</p>	0h
				<p>_ x _ _:</p> <p>For manufacturer setting</p>	0h
				<p>x _ _ _:</p> <p>For manufacturer setting</p>	0h
				<p>Function selection B-1</p> <p>Select enabled/disabled of model adaptive control.</p> <p>This parameter is used by servo amplifier with software version B4 or later.</p>	
				<p>___ x:</p> <p>Model adaptive control selection</p> <p>0: Enabled (model adaptive control)</p> <p>2: Disabled (PID control)</p>	0h
				<p>_ _ x _:</p> <p>For manufacturer setting</p>	0h
				<p>_ x _ _:</p> <p>For manufacturer setting</p>	0h
				<p>x _ _ _:</p> <p>For manufacturer setting</p>	0h

Part 4: Replacement of MR-J3W-_B with MR-J4W2-_B

MR-J3W-_B			MR-J4W2-_B			
No.	Name and function	Initial value	No.	Name and function	Initial value	
PB26	Gain changing selection Select the gain changing condition.	0000h	PB26	Gain switching function Select the gain switching condition. Set conditions to enable the gain switching values set in [Pr. PB29] to [Pr. PB36] and [Pr. PB56] to [Pr. PB60].		
	0 0 _ x : Gain changing selection Under any of the following conditions, the gains change on the basis of the [Pr. PB29 to PB34] settings. 0: Invalid 1: Control instructions from a controller. 2: Command frequency ([Pr. PB27] setting) 3: Droop pulses value ([Pr. PB27] setting) 4: Servo motor speed ([Pr. PB27] setting)			_ _ _ x : Gain switching selection 0: Disabled 1: Control command from controller is enabled 2: Command frequency 3: Droop pulses 4: Servo motor speed/linear servo motor speed		0h
	0 0 x _ : Gain changing condition 0: Valid when the control instruction from a controller is ON Valid at equal to or more than the value set in [Pr. PB27] 1: Valid when the control instruction from a controller is OFF Valid at equal to or less than the value set in [Pr. PB27]			_ _ x _ : Gain switching condition selection 0: Gain after switching is enabled with gain switching condition or more 1: Gain after switching is enabled with gain switching condition or less		0h
			_ x _ _ : Gain switching time constant disabling condition selection 0: Switching time constant enabled 1: Switching time constant disabled 2: Return time constant disabled This digit is available with servo amplifier with software version B4 or later.	0h		
			x _ _ _ : For manufacturer setting	0h		
PB27	Gain changing condition Used to set the value of gain changing condition (command frequency, droop pulses, servo motor speed) selected in [Pr. PB26]. The set value unit changes with the changing condition item.	10	PB27	Gain switching condition Set a value of gain switching (command frequency, droop pulses, and servo motor speed/linear servo motor speed) selected in [Pr. PB26]. The set value unit differs depending on the switching condition item.	10	
PB28	Gain changing time constant Used to set the time constant at which the gains will change in response to the conditions set in [Pr. PB26] and [Pr. PB27].	1	PB28	Gain switching time constant Set the time constant until the gains switch in response to the conditions set in [Pr. PB26] and [Pr. PB27].	1	
PB29	Gain changing load to motor inertia moment ratio Used to set the load to motor inertia moment ratio when gain changing is valid. This parameter is made valid when the auto tuning is invalid ([Pr. PA08]: _ _ _ 3).	7.0	PB29	Load to motor inertia ratio/load to motor mass ratio after gain switching Set a load to motor inertia ratio/load to motor mass ratio for when gain switching is enabled. This parameter is enabled only when you select "Manual mode (_ _ _ 3)" of "Gain adjustment mode selection" in [Pr. PA08].	7.00	
PB30	Gain changing position loop gain This parameter cannot be used in the speed control mode. Set the position loop gain when the gain changing is valid. This parameter is made valid when the auto tuning is invalid ([Pr. PA08]: _ _ _ 3).	37	PB30	Position loop gain after gain switching Set the position loop gain when the gain switching is enabled. When you set a value less than 1.0 rad/s, the value will be the same as [Pr. PB08]. This parameter is enabled only when you select "Manual mode (_ _ _ 3)" of "Gain adjustment mode selection" in [Pr. PA08].	0.0	
PB31	Gain changing speed loop gain Set the speed loop gain when the gain changing is valid. This parameter is made valid when the auto tuning is invalid ([Pr. PA08]: _ _ _ 3).	823	PB31	Speed loop gain after gain switching Set the speed loop gain when the gain switching is enabled. When you set a value less than 20 rad/s, the value will be the same as [Pr. PB09]. This parameter is enabled only when you select "Manual mode (_ _ _ 3)" of "Gain adjustment mode selection" in [Pr. PA08].	0	

Part 4: Replacement of MR-J3W-_B with MR-J4W2-_B

MR-J3W-_B			MR-J4W2-_B		
No.	Name and function	Initial value	No.	Name and function	Initial value
PB32	Gain changing speed integral compensation Set the speed integral compensation when the gain changing is valid. This parameter is made valid when the auto tuning is invalid ([Pr. PA08]: ___ 3).	33.7	PB32	Speed integral compensation after gain switching Set the speed integral compensation when the gain changing is enabled. When you set a value less than 0.1 ms, the value will be the same as [Pr. PB10]. This parameter is enabled only when you select "Manual mode (___ 3)" of "Gain adjustment mode selection" in [Pr. PA08].	0.0
PB33	Gain changing vibration suppression control vibration frequency setting This parameter cannot be used in the speed control mode. Set the vibration frequency for vibration suppression control when the gain changing is valid. This parameter is made valid when the [Pr. PB02] setting is "___ 2" and the [Pr. PB26] setting is "___ 1". When using the vibration suppression control gain changing, always execute the changing after the servo motor has stopped.	100.0	PB33	Vibration suppression control 1 - Vibration frequency after gain switching Set the vibration frequency of the vibration suppression control 1 for when the gain switching is enabled. When you set a value less than 0.1 Hz, the value will be the same as [Pr. PB19]. This parameter is enabled only when the following conditions are fulfilled. <ul style="list-style-type: none"> "Gain adjustment mode selection" in [Pr. PA08] is "Manual mode (___ 3)". "Vibration suppression control 1 tuning mode selection" in [Pr. PB02] is "Manual setting (___ 2)". "Gain switching selection" in [Pr. PB26] is "Control command from controller is enabled (___ 1)". Switching during driving may cause a shock. Be sure to switch them after the servo motor stops.	0.0
PB34	Gain changing vibration suppression control resonance frequency setting This parameter cannot be used in the speed control mode. Set the resonance frequency for vibration suppression control when the gain changing is valid. This parameter is made valid when the [Pr. PB02] setting is "___ 2" and the [Pr. PB26] setting is "___ 1". When using the vibration suppression control gain changing, always execute the changing after the servo motor has stopped.	100.0	PB34	Vibration suppression control 1 - Resonance frequency after gain switching Set the resonance frequency for vibration suppression control 1 when the gain switching is enabled. When you set a value less than 0.1 Hz, the value will be the same as [Pr. PB20]. This parameter will be enabled only when the following conditions are fulfilled. <ul style="list-style-type: none"> "Gain adjustment mode selection" in [Pr. PA08] is "Manual mode (___ 3)". "Vibration suppression control 1 tuning mode selection" in [Pr. PB02] is "Manual setting (___ 2)". "Gain switching selection" in [Pr. PB26] is "Control command from controller is enabled (___ 1)". Switching during driving may cause a shock. Be sure to switch them after the servo motor stops.	0.0
PB35	This parameter is not used. Do not change the value.	0.00	PB35	Vibration suppression control 1 - Vibration frequency damping after gain switching Set a damping of the vibration frequency for vibration suppression control 1 when the gain switching is enabled. This parameter will be enabled only when the following conditions are fulfilled. <ul style="list-style-type: none"> "Gain adjustment mode selection" in [Pr. PA08] is "Manual mode (___ 3)". "Vibration suppression control 1 tuning mode selection" in [Pr. PB02] is "Manual setting (___ 2)". "Gain switching selection" in [Pr. PB26] is "Control command from controller is enabled (___ 1)". Switching during driving may cause a shock. Be sure to switch them after the servo motor stops.	0.00
PB36	This parameter is not used. Do not change the value.	0.00	PB36	Vibration suppression control 1 - Resonance frequency damping after gain switching Set a damping of the resonance frequency for vibration suppression control 1 when the gain switching is enabled. This parameter will be enabled only when the following conditions are fulfilled. <ul style="list-style-type: none"> "Gain adjustment mode selection" in [Pr. PA08] is "Manual mode (___ 3)". "Vibration suppression control 1 tuning mode selection" in [Pr. PB02] is "Manual setting (___ 2)". "Gain switching selection" in [Pr. PB26] is "Control command from controller is enabled (___ 1)". Switching during driving may cause a shock. Be sure to switch them after the servo motor stops.	0.00

Part 4: Replacement of MR-J3W-_B with MR-J4W2-_B

MR-J3W-_B			MR-J4W2-_B																																																																																																																																																																																																																																												
No.	Name and function	Initial value	No.	Name and function	Initial value																																																																																																																																																																																																																																										
PB45	This parameter is not used. Do not change the value.	0000h	PB45	<p>Command notch filter Set the command notch filter.</p> <p>__ x x: Command notch filter setting frequency selection Refer to table 4.4 for the relation of setting values to frequency.</p> <p>_ x __ : Notch depth selection Refer to table 4.5 for details.</p> <p>x ___ : For manufacturer setting</p> <p>Table 4.4 Command notch filter setting frequency selection</p> <table border="1"> <thead> <tr> <th>Setting value</th> <th>Frequency [Hz]</th> <th>Setting value</th> <th>Frequency [Hz]</th> <th>Setting value</th> <th>Frequency [Hz]</th> </tr> </thead> <tbody> <tr><td>__ 0 0</td><td>Disabled</td><td>__ 2 0</td><td>70</td><td>__ 4 0</td><td>17.6</td></tr> <tr><td>__ 0 1</td><td>2250</td><td>__ 2 1</td><td>66</td><td>__ 4 1</td><td>16.5</td></tr> <tr><td>__ 0 2</td><td>1125</td><td>__ 2 2</td><td>62</td><td>__ 4 2</td><td>15.6</td></tr> <tr><td>__ 0 3</td><td>750</td><td>__ 2 3</td><td>59</td><td>__ 4 3</td><td>14.8</td></tr> <tr><td>__ 0 4</td><td>562</td><td>__ 2 4</td><td>56</td><td>__ 4 4</td><td>14.1</td></tr> <tr><td>__ 0 5</td><td>450</td><td>__ 2 5</td><td>53</td><td>__ 4 5</td><td>13.4</td></tr> <tr><td>__ 0 6</td><td>375</td><td>__ 2 6</td><td>51</td><td>__ 4 6</td><td>12.8</td></tr> <tr><td>__ 0 7</td><td>321</td><td>__ 2 7</td><td>48</td><td>__ 4 7</td><td>12.2</td></tr> <tr><td>__ 0 8</td><td>281</td><td>__ 2 8</td><td>46</td><td>__ 4 8</td><td>11.7</td></tr> <tr><td>__ 0 9</td><td>250</td><td>__ 2 9</td><td>45</td><td>__ 4 9</td><td>11.3</td></tr> <tr><td>__ 0 A</td><td>225</td><td>__ 2 A</td><td>43</td><td>__ 4 A</td><td>10.8</td></tr> <tr><td>__ 0 B</td><td>204</td><td>__ 2 B</td><td>41</td><td>__ 4 B</td><td>10.4</td></tr> <tr><td>__ 0 C</td><td>187</td><td>__ 2 C</td><td>40</td><td>__ 4 C</td><td>10</td></tr> <tr><td>__ 0 D</td><td>173</td><td>__ 2 D</td><td>38</td><td>__ 4 D</td><td>9.7</td></tr> <tr><td>__ 0 E</td><td>160</td><td>__ 2 E</td><td>37</td><td>__ 4 E</td><td>9.4</td></tr> <tr><td>__ 0 F</td><td>150</td><td>__ 2 F</td><td>36</td><td>__ 4 F</td><td>9.1</td></tr> <tr><td>__ 1 0</td><td>140</td><td>__ 3 0</td><td>35.2</td><td>__ 5 0</td><td>8.8</td></tr> <tr><td>__ 1 1</td><td>132</td><td>__ 3 1</td><td>33.1</td><td>__ 5 1</td><td>8.3</td></tr> <tr><td>__ 1 2</td><td>125</td><td>__ 3 2</td><td>31.3</td><td>__ 5 2</td><td>7.8</td></tr> <tr><td>__ 1 3</td><td>118</td><td>__ 3 3</td><td>29.6</td><td>__ 5 3</td><td>7.4</td></tr> <tr><td>__ 1 4</td><td>112</td><td>__ 3 4</td><td>28.1</td><td>__ 5 4</td><td>7.0</td></tr> <tr><td>__ 1 5</td><td>107</td><td>__ 3 5</td><td>26.8</td><td>__ 5 5</td><td>6.7</td></tr> <tr><td>__ 1 6</td><td>102</td><td>__ 3 6</td><td>25.6</td><td>__ 5 6</td><td>6.4</td></tr> <tr><td>__ 1 7</td><td>97</td><td>__ 3 7</td><td>24.5</td><td>__ 5 7</td><td>6.1</td></tr> <tr><td>__ 1 8</td><td>93</td><td>__ 3 8</td><td>23.4</td><td>__ 5 8</td><td>5.9</td></tr> <tr><td>__ 1 9</td><td>90</td><td>__ 3 9</td><td>22.5</td><td>__ 5 9</td><td>5.6</td></tr> <tr><td>__ 1 A</td><td>86</td><td>__ 3 A</td><td>21.6</td><td>__ 5 A</td><td>5.4</td></tr> <tr><td>__ 1 B</td><td>83</td><td>__ 3 B</td><td>20.8</td><td>__ 5 B</td><td>5.2</td></tr> <tr><td>__ 1 C</td><td>80</td><td>__ 3 C</td><td>20.1</td><td>__ 5 C</td><td>5.0</td></tr> <tr><td>__ 1 D</td><td>77</td><td>__ 3 D</td><td>19.4</td><td>__ 5 D</td><td>4.9</td></tr> <tr><td>__ 1 E</td><td>75</td><td>__ 3 E</td><td>18.8</td><td>__ 5 E</td><td>4.7</td></tr> <tr><td>__ 1 F</td><td>72</td><td>__ 3 F</td><td>18.2</td><td>__ 5 F</td><td>4.5</td></tr> </tbody> </table> <p>Table 4.5 Notch depth selection</p> <table border="1"> <thead> <tr> <th>Setting value</th> <th>Depth [dB]</th> <th>Setting value</th> <th>Depth [dB]</th> </tr> </thead> <tbody> <tr><td>_ 0 _ _</td><td>-40.0</td><td>_ 8 _ _</td><td>-6.0</td></tr> <tr><td>_ 1 _ _</td><td>-24.1</td><td>_ 9 _ _</td><td>-5.0</td></tr> <tr><td>_ 2 _ _</td><td>-18.1</td><td>_ A _ _</td><td>-4.1</td></tr> <tr><td>_ 3 _ _</td><td>-14.5</td><td>_ B _ _</td><td>-3.3</td></tr> <tr><td>_ 4 _ _</td><td>-12.0</td><td>_ C _ _</td><td>-2.5</td></tr> <tr><td>_ 5 _ _</td><td>-10.1</td><td>_ D _ _</td><td>-1.8</td></tr> <tr><td>_ 6 _ _</td><td>-8.5</td><td>_ E _ _</td><td>-1.2</td></tr> <tr><td>_ 7 _ _</td><td>-7.2</td><td>_ F _ _</td><td>-0.6</td></tr> </tbody> </table>	Setting value	Frequency [Hz]	Setting value	Frequency [Hz]	Setting value	Frequency [Hz]	__ 0 0	Disabled	__ 2 0	70	__ 4 0	17.6	__ 0 1	2250	__ 2 1	66	__ 4 1	16.5	__ 0 2	1125	__ 2 2	62	__ 4 2	15.6	__ 0 3	750	__ 2 3	59	__ 4 3	14.8	__ 0 4	562	__ 2 4	56	__ 4 4	14.1	__ 0 5	450	__ 2 5	53	__ 4 5	13.4	__ 0 6	375	__ 2 6	51	__ 4 6	12.8	__ 0 7	321	__ 2 7	48	__ 4 7	12.2	__ 0 8	281	__ 2 8	46	__ 4 8	11.7	__ 0 9	250	__ 2 9	45	__ 4 9	11.3	__ 0 A	225	__ 2 A	43	__ 4 A	10.8	__ 0 B	204	__ 2 B	41	__ 4 B	10.4	__ 0 C	187	__ 2 C	40	__ 4 C	10	__ 0 D	173	__ 2 D	38	__ 4 D	9.7	__ 0 E	160	__ 2 E	37	__ 4 E	9.4	__ 0 F	150	__ 2 F	36	__ 4 F	9.1	__ 1 0	140	__ 3 0	35.2	__ 5 0	8.8	__ 1 1	132	__ 3 1	33.1	__ 5 1	8.3	__ 1 2	125	__ 3 2	31.3	__ 5 2	7.8	__ 1 3	118	__ 3 3	29.6	__ 5 3	7.4	__ 1 4	112	__ 3 4	28.1	__ 5 4	7.0	__ 1 5	107	__ 3 5	26.8	__ 5 5	6.7	__ 1 6	102	__ 3 6	25.6	__ 5 6	6.4	__ 1 7	97	__ 3 7	24.5	__ 5 7	6.1	__ 1 8	93	__ 3 8	23.4	__ 5 8	5.9	__ 1 9	90	__ 3 9	22.5	__ 5 9	5.6	__ 1 A	86	__ 3 A	21.6	__ 5 A	5.4	__ 1 B	83	__ 3 B	20.8	__ 5 B	5.2	__ 1 C	80	__ 3 C	20.1	__ 5 C	5.0	__ 1 D	77	__ 3 D	19.4	__ 5 D	4.9	__ 1 E	75	__ 3 E	18.8	__ 5 E	4.7	__ 1 F	72	__ 3 F	18.2	__ 5 F	4.5	Setting value	Depth [dB]	Setting value	Depth [dB]	_ 0 _ _	-40.0	_ 8 _ _	-6.0	_ 1 _ _	-24.1	_ 9 _ _	-5.0	_ 2 _ _	-18.1	_ A _ _	-4.1	_ 3 _ _	-14.5	_ B _ _	-3.3	_ 4 _ _	-12.0	_ C _ _	-2.5	_ 5 _ _	-10.1	_ D _ _	-1.8	_ 6 _ _	-8.5	_ E _ _	-1.2	_ 7 _ _	-7.2	_ F _ _	-0.6	00h 0h 0h
Setting value	Frequency [Hz]	Setting value	Frequency [Hz]	Setting value	Frequency [Hz]																																																																																																																																																																																																																																										
__ 0 0	Disabled	__ 2 0	70	__ 4 0	17.6																																																																																																																																																																																																																																										
__ 0 1	2250	__ 2 1	66	__ 4 1	16.5																																																																																																																																																																																																																																										
__ 0 2	1125	__ 2 2	62	__ 4 2	15.6																																																																																																																																																																																																																																										
__ 0 3	750	__ 2 3	59	__ 4 3	14.8																																																																																																																																																																																																																																										
__ 0 4	562	__ 2 4	56	__ 4 4	14.1																																																																																																																																																																																																																																										
__ 0 5	450	__ 2 5	53	__ 4 5	13.4																																																																																																																																																																																																																																										
__ 0 6	375	__ 2 6	51	__ 4 6	12.8																																																																																																																																																																																																																																										
__ 0 7	321	__ 2 7	48	__ 4 7	12.2																																																																																																																																																																																																																																										
__ 0 8	281	__ 2 8	46	__ 4 8	11.7																																																																																																																																																																																																																																										
__ 0 9	250	__ 2 9	45	__ 4 9	11.3																																																																																																																																																																																																																																										
__ 0 A	225	__ 2 A	43	__ 4 A	10.8																																																																																																																																																																																																																																										
__ 0 B	204	__ 2 B	41	__ 4 B	10.4																																																																																																																																																																																																																																										
__ 0 C	187	__ 2 C	40	__ 4 C	10																																																																																																																																																																																																																																										
__ 0 D	173	__ 2 D	38	__ 4 D	9.7																																																																																																																																																																																																																																										
__ 0 E	160	__ 2 E	37	__ 4 E	9.4																																																																																																																																																																																																																																										
__ 0 F	150	__ 2 F	36	__ 4 F	9.1																																																																																																																																																																																																																																										
__ 1 0	140	__ 3 0	35.2	__ 5 0	8.8																																																																																																																																																																																																																																										
__ 1 1	132	__ 3 1	33.1	__ 5 1	8.3																																																																																																																																																																																																																																										
__ 1 2	125	__ 3 2	31.3	__ 5 2	7.8																																																																																																																																																																																																																																										
__ 1 3	118	__ 3 3	29.6	__ 5 3	7.4																																																																																																																																																																																																																																										
__ 1 4	112	__ 3 4	28.1	__ 5 4	7.0																																																																																																																																																																																																																																										
__ 1 5	107	__ 3 5	26.8	__ 5 5	6.7																																																																																																																																																																																																																																										
__ 1 6	102	__ 3 6	25.6	__ 5 6	6.4																																																																																																																																																																																																																																										
__ 1 7	97	__ 3 7	24.5	__ 5 7	6.1																																																																																																																																																																																																																																										
__ 1 8	93	__ 3 8	23.4	__ 5 8	5.9																																																																																																																																																																																																																																										
__ 1 9	90	__ 3 9	22.5	__ 5 9	5.6																																																																																																																																																																																																																																										
__ 1 A	86	__ 3 A	21.6	__ 5 A	5.4																																																																																																																																																																																																																																										
__ 1 B	83	__ 3 B	20.8	__ 5 B	5.2																																																																																																																																																																																																																																										
__ 1 C	80	__ 3 C	20.1	__ 5 C	5.0																																																																																																																																																																																																																																										
__ 1 D	77	__ 3 D	19.4	__ 5 D	4.9																																																																																																																																																																																																																																										
__ 1 E	75	__ 3 E	18.8	__ 5 E	4.7																																																																																																																																																																																																																																										
__ 1 F	72	__ 3 F	18.2	__ 5 F	4.5																																																																																																																																																																																																																																										
Setting value	Depth [dB]	Setting value	Depth [dB]																																																																																																																																																																																																																																												
_ 0 _ _	-40.0	_ 8 _ _	-6.0																																																																																																																																																																																																																																												
_ 1 _ _	-24.1	_ 9 _ _	-5.0																																																																																																																																																																																																																																												
_ 2 _ _	-18.1	_ A _ _	-4.1																																																																																																																																																																																																																																												
_ 3 _ _	-14.5	_ B _ _	-3.3																																																																																																																																																																																																																																												
_ 4 _ _	-12.0	_ C _ _	-2.5																																																																																																																																																																																																																																												
_ 5 _ _	-10.1	_ D _ _	-1.8																																																																																																																																																																																																																																												
_ 6 _ _	-8.5	_ E _ _	-1.2																																																																																																																																																																																																																																												
_ 7 _ _	-7.2	_ F _ _	-0.6																																																																																																																																																																																																																																												
PC01	<p>Error excessive alarm level This parameter cannot be used in the speed control mode and the torque control mode. Used to set the error excessive alarm level with rotation amount of servo motor. When "0" is set in this parameter, the alarm level is three rotations. When a value other than "0" is set, the alarm level is the rotation number of the set value. However, the alarm level stays at 200 rotations even if a value exceeding "200" is set. Note. Setting can be changed in [Pr. PC06].</p>	0	PC01	<p>Error excessive alarm level Set an error excessive alarm level. Set this per rev. for rotary servo motors and direct drive motors. Setting "0" will be 3 rev. Setting over 200 rev will be clamped with 200 rev. Note. Setting can be changed in [Pr. PC06].</p>	0																																																																																																																																																																																																																																										

Part 4: Replacement of MR-J3W-_B with MR-J4W2-_B

MR-J3W-_B			MR-J4W2-_B																								
No.	Name and function	Initial value	No.	Name and function	Initial value																						
PC02	Electromagnetic brake sequence output Used to set the delay time (Tb) between electronic brake interlock (MBR-A/MBR-B) and the base drive circuit is shut-off.	0	PC02	Electromagnetic brake sequence output Set a delay time between MBR (Electromagnetic brake interlock) and the base drive circuit is shut-off.	0																						
PC03	Encoder output pulse selection Use to select the encoder output pulse direction and encoder output pulse setting.	0010h	PC03	Encoder output pulse selection Select an encoder pulse direction and encoder output pulse setting.	0h																						
	0 0 _ x: Encoder output pulse phase changing Changes the phases of A/B-phase encoder pulses output .			___ x: Encoder output pulse phase selection 0: Increasing A-phase 90° in CCW or positive direction 1: Increasing A-phase 90° in CW or negative direction																							
	<table border="1"> <thead> <tr> <th rowspan="2">Setting value</th> <th colspan="2">Servo motor rotation direction</th> </tr> <tr> <th>CCW</th> <th>CW</th> </tr> </thead> <tbody> <tr> <td>0</td> <td>A-phase B-phase </td> <td>A-phase B-phase </td> </tr> <tr> <td>1</td> <td>A-phase B-phase </td> <td>A-phase B-phase </td> </tr> </tbody> </table>			Setting value		Servo motor rotation direction		CCW	CW	0	A-phase B-phase	A-phase B-phase	1	A-phase B-phase	A-phase B-phase	<table border="1"> <thead> <tr> <th rowspan="2">Setting value</th> <th colspan="2">Servo motor rotation direction</th> </tr> <tr> <th>CCW or positive direction</th> <th>CW or negative direction</th> </tr> </thead> <tbody> <tr> <td>0</td> <td>A-phase B-phase </td> <td>A-phase B-phase </td> </tr> <tr> <td>1</td> <td>A-phase B-phase </td> <td>A-phase B-phase </td> </tr> </tbody> </table>	Setting value	Servo motor rotation direction		CCW or positive direction	CW or negative direction	0	A-phase B-phase	A-phase B-phase	1	A-phase B-phase	A-phase B-phase
	Setting value					Servo motor rotation direction																					
CCW		CW																									
0	A-phase B-phase	A-phase B-phase																									
1	A-phase B-phase	A-phase B-phase																									
Setting value	Servo motor rotation direction																										
	CCW or positive direction	CW or negative direction																									
0	A-phase B-phase	A-phase B-phase																									
1	A-phase B-phase	A-phase B-phase																									
0 0 x _: Encoder output pulse setting selection 0: Output pulse designation 1: Division ratio setting 3: A/B-phase pulse electronic gear setting (Set with the electronic gear [Pr. PA15] and [Pr. PA16])	___ x _: Encoder output pulse setting selection 0: Output pulse setting When "_ 1 0_" is set to this parameter, [AL. 37 Parameter error] will occur. 1: Division ratio setting 3: A/B-phase pulse electronic gear setting																										
	_ x _ _: Selection of the encoders for encoder output pulse Select an encoder used the encoder output pulses which the servo amplifier outputs. 0: Servo motor encoder 1: Load-side encoder When "_ 1 0_" is set to this parameter, [AL. 37 Parameter error] will occur.	0h																									
	x _ _ _: For manufacturer setting	0h																									
PC04	Function selection C-1 Select the encoder cable communication system selection. x 0 0 0: Encoder cable communication system selection 0: Two-wire type 1: Four-wire type Incorrect setting will result in an encoder alarm 1 (16.3). Refer to "MR-J3W-0303BN6 MR-J3W-_B Servo Amplifier Instruction Manual" for the communication method of the encoder cable.	0000h	PC04	Function selection C-1 Select the encoder cable communication method selection.	0h																						
				___ x: For manufacturer setting		0h																					
				__ x _: For manufacturer setting		0h																					
				_ x _ _: For manufacturer setting		0h																					
				x _ _ _: Encoder cable communication method selection 0: Two-wire type 1: Four-wire type Incorrect setting will result in [AL. 16 Encoder initial communication error 1]- or [AL. 20 Encoder initial communication error 1] will occur. Setting "1" will trigger [AL. 37] while "Fully closed loop control mode (_ _ 1 _)" is selected in [Pr. PA01]. For MR-J4W2-0303B6 servo amplifiers, this digit cannot be used other than the initial value.		0h																					

Part 4: Replacement of MR-J3W-_B with MR-J4W2-_B

MR-J3W-_B			MR-J4W2-_B		
No.	Name and function	Initial value	No.	Name and function	Initial value
PC05	Function selection C-2 Motor-less operation select. 0 0 0 x: Motor-less operation select. 0: Valid 1: Invalid	0000h	PC05	Function selection C-2 Set the motor-less operation, servo motor main circuit power supply, and [AL. 9B Error excessive warning].	
			___ x:	Motor-less operation selection 0: Disabled 1: Enabled	0h
			_ _ x _:	For manufacturer setting	0h
			_ x _ _:	Main circuit power supply selection Select a voltage to be connected to the main circuit power supply with an MR-J4W2-0303B6 servo amplifier. 0: 48 V DC 1: 24 V DC When using 24 V DC for the main circuit power supply, set "1" to this digit. The setting of this digit in the J3 compatibility mode is the same as the MR-J3W-0303BN6 servo amplifier. Set it with [Pr. Po04]. For details, refer to "MR-J3W-0303BN6 MR-J3W-_B Servo Amplifier Instruction Manual". This digit is not available with MR-J4W-_B 200 W or more servo amplifiers. The characteristics of the servo motor vary depending on whether 48 V DC or 24 V DC is used. For details, refer to "HG-MR/HG-KR/HG-SR/HG-JR/HG-RR/HG-UR/HG-AK Servo Motor Instruction Manual (Vol. 3)".	0h
x _ _ _:	[AL. 9B Error excessive warning] selection 0: [AL. 9B Error excessive warning] is disabled. 1: [AL. 9B Error excessive warning] is enabled. The setting of this digit is used by servo amplifier with software version B4 or later.	0h			
PC06	Function selection C-3 The parameter is not available in the speed control mode and torque control mode. Select the error excessive alarm level setting for [Pr. PC01]. x 0 0 0: Error excessive alarm level setting selection 0: 1 [rev] unit 1: 0.1 [rev] unit 2: 0.01 [rev] unit 3: 0.001[rev] unit	0000h	PC06	Function selection C-3 Select units for error excessive alarm level setting with [Pr. PC01] and for error excessive warning level setting with [Pr. PC38]. The parameter is not available in the speed control mode and torque control mode.	
			___ x:	For manufacturer setting	0h
			_ _ x _:	For manufacturer setting	0h
			_ x _ _:	For manufacturer setting	0h
x _ _ _:	Error excessive alarm/error excessive warning level unit selection 0: Per rev or mm 1: Per 0.1 rev or 0.1 mm 2: Per 0.01 rev or 0.01 mm 3: Per 0.001 rev or 0.001 mm	0h			
PC07	Zero speed Used to set the output range of the zero speed (ZSP-A/ZSP-B). Zero speed (ZSP-A/ZSP-B) detection has hysteresis width of 20 r/min.	50	PC07	Zero speed Set an output range of ZSP (Zero speed detection). ZSP (Zero speed detection) has hysteresis of 20 r/min or 20 mm/s.	50
PC08	This parameter is not used. Do not change the value.	0	PC08	Overspeed alarm detection level Set an overspeed alarm detection level. When you set a value more than "servo motor maximum speed × 120%", the set value will be clamped. When you set "0", the value of "servo motor maximum speed × 120%" will be set.	0

Part 4: Replacement of MR-J3W-_B with MR-J4W2-_B

MR-J3W-_B			MR-J4W2-_B		
No.	Name and function	Initial value	No.	Name and function	Initial value
PC09	Analog monitor 1 output Used to selection the signal provided to the analog monitor 1 (MO1) output.	0000h	PC09	Analog monitor 1 output Select a signal to output to MO1 (Analog monitor 1). Refer to "MR-J4W2-_B/MRJ4W3-_B/MR-J4W2-0303B6 Servo Amplifier Instruction Manual" for detection point of output selection. The parameter is available with MR-J4W2-0303B6 servo amplifiers.	00h
	_ 0 0 x: Analog monitor 1 (MO1) output selection 0: Servo motor speed (±8 V/max. speed) 1: Torque (±8 V/max. torque) 2: Servo motor speed (+8 V/max. speed) 3: Torque (+8 V /max. torque) 4: Current command (8V/max. current command) 5: Speed command (8V/max. current command) 6: Droop pulses (10V/100 pulses) 7: Droop pulses (10V/1000 pulses) 8: Droop pulses (10V/10000 pulses) 9: Droop pulses (10V/100000 pulses) D: Bus voltage (8V/400V) E: Speed command 2 (8V/max. current command) In the case of MR-J3W-0303BN6 is as follows. 0: Servo motor speed (10 V ± 4 V/max. speed) 1: Torque (10 V ± 4 V/max. torque) 2: Servo motor speed (10 V + 4 V/max. speed) 3: Torque (10 V + 4 V/max. torque) 4: Current command (10 V ± 4 V/max. current command) 5: Speed command (10 V ± 4 V/max. speed) 6: Droop pulses (10 V ± 5 V/100 pulses) 7: Droop pulses (10 V ± 5 V/1000 pulses) 8: Droop pulses (10 V ± 5 V/10000 pulses) 9: Droop pulses (10 V ± 5 V/100000 pulses) D: Bus voltage (10 V + 5 V/400 V) E: Speed command 2 (10 V ± 4 V/max. speed)				
	x 0 0 _: Analog monitor 1 (MO1) output axis selection 0: A-axis 1: B-axis				
PC10	Analog monitor 2 output Used to selection the signal provided to the analog monitor 2 (MO2) output.	0001h	PC10	Analog monitor 2 output Select a signal to output to MO2 (Analog monitor 2). Refer to "MR-J4W2-_B/MRJ4W3-_B/MR-J4W2-0303B6 Servo Amplifier Instruction Manual" for detection point of output selection. The parameter is available with MR-J4W2-0303B6 servo amplifiers.	01h
	_ 0 0 x: Analog monitor 2 (MO2) output selection The settings are the same as those of [Pr. PC09].				
	X 0 0 _: Analog monitor 2 (MO2) output axis selection The settings are the same as those of [Pr. PC09].				
PC11	Analog monitor 1 offset Used to set the offset voltage of the analog monitor 1 (MO1) output.	0	PC11	Analog monitor 1 offset Set the offset voltage of MO1 (Analog monitor 1). The parameter is available with MR-J4W2-0303B6 servo amplifiers.	0
	_ x _ _: For manufacturer setting			0h	
	x _ _ _: Analog monitor 1 output axis selection Select an output axis of Analog monitor 1. 0: A-axis 1: B-axis			0h	
PC10	Analog monitor 2 output Used to selection the signal provided to the analog monitor 2 (MO2) output.	0001h	PC10	Analog monitor 2 output Select a signal to output to MO2 (Analog monitor 2). Refer to "MR-J4W2-_B/MRJ4W3-_B/MR-J4W2-0303B6 Servo Amplifier Instruction Manual" for detection point of output selection. The parameter is available with MR-J4W2-0303B6 servo amplifiers.	01h
	_ 0 0 x: Analog monitor 2 (MO2) output selection The settings are the same as those of [Pr. PC09].				
	X 0 0 _: Analog monitor 2 (MO2) output axis selection The settings are the same as those of [Pr. PC09].				
PC11	Analog monitor 1 offset Used to set the offset voltage of the analog monitor 1 (MO1) output.	0	PC11	Analog monitor 1 offset Set the offset voltage of MO1 (Analog monitor 1). The parameter is available with MR-J4W2-0303B6 servo amplifiers.	0
	_ x _ _: For manufacturer setting			0h	
	x _ _ _: Analog monitor 2 output axis selection The settings are the same as those of [Pr. PC09].			0h	

Part 4: Replacement of MR-J3W-_B with MR-J4W2-_B

MR-J3W-_B			MR-J4W2-_B		
No.	Name and function	Initial value	No.	Name and function	Initial value
PC12	Analog monitor 2 offset Used to set the offset voltage of the analog monitor 2 (MO2) output.	0	PC12	Analog monitor 2 offset Set the offset voltage of MO2 (Analog monitor 2). The parameter is available with MR-J4W2-0303B6 servo amplifiers.	0
PC13	This parameter is not used. Do not change this value by any means.	0	PC13	Analog monitor - Feedback position output standard data - Low Set a monitor output standard position (lower 4 digits) for the feedback position for when selecting "Feedback position" for MO1 (Analog monitor 1) and MO2 (Analogmonitor 2). Monitor output standard position = [Pr. PC14] setting × 10000 + [Pr. PC13] setting The parameter is available with MR-J4W2-0303B6 servo amplifiers.	0
PC14	This parameter is not used. Do not change this value by any means.	0	PC14	Analog monitor - Feedback position output standard data - High Set a monitor output standard position (higher 4 digits) for the feedback position for when selecting "Feedback position" for MO1 (Analog monitor 1) and MO2 (Analogmonitor 2). Monitor output standard position = [Pr. PC14] setting × 10000 + [Pr. PC13] setting The parameter is available with MR-J4W2-0303B6 servo amplifiers.	0
PC15	Station number selection Used to select the axis to communicate with (SETUP221E). 0: A-axis 1: B-axis	0000h	PC15	For manufacturer setting	0
PC17	Function Selection C-4 This parameter cannot be used in the speed control mode and the torque control mode. This is used to select a home position setting condition. 0 0 0 x: Selection of home position setting condition 0: Need to pass motor Z-phase after the power supply is switched on. 1: Not need to pass motor Z-phase after the power supply is switched on.	0000h	PC17	Function selection C-4 Select a home position setting condition.	
				___ x:	0h
				Selection of home position setting condition 0: Need to pass servo motor Z-phase after power on 1: Not need to pass servo motor Z-phase after power on	
				_ x _:	0h
				When a rotary servo motor is used, the setting does not need to be changed.	
	_ x _:	0h			
	For manufacturer setting				
	x _ _:	0h			
	For manufacturer setting				
PC18	This parameter is not used. Do not change the value.	0000h	PC18	Function selection C-5 Select an occurring condition of [AL. E9 Main circuit off warning].	
				___ x:	0h
				For manufacturer setting	
				_ x _:	0h
				For manufacturer setting	
	_ x _:	0h			
	For manufacturer setting				
	x _ _:	0h			
	[AL. E9 Main circuit off warning] selection 0: Detection with ready-on and servo-on command 1: Detection with servo-on command				

Part 4: Replacement of MR-J3W-_B with MR-J4W2-_B

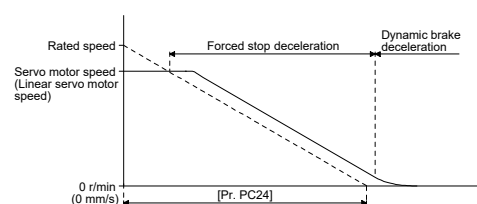
MR-J3W-_B			MR-J4W2-_B		
No.	Name and function	Initial value	No.	Name and function	Initial value
PC20	This parameter is not used. Do not change the value.	0000h	PC20	Function selection C-7 Select the detection method of [AL. 10 Undervoltage]. __ _ x: For manufacturer setting _ _ x _: For manufacturer setting _ x _ _: Undervoltage alarm selection Select the alarm/alarm and warning for when the bus voltage drops to the undervoltage alarm level. 0: [AL. 10] regardless of servo motor speed 1: [AL. E9] at servo motor speed 50 r/min (50 mm/s) or less, [AL. 10] at over 50 r/min (50 mm/s) x _ _ _: For manufacturer setting	0h 0h 0h 0h
PC21	Alarm history clear Used to clear the alarm history. 0 0 0 x: Alarm history clear 0: Invalid 1: Valid When alarm history clear is made valid, the alarm history is cleared at next power-on. After the alarm history is cleared, the setting is automatically made invalid (reset to 0).	0000h	PC21	Alarm history clear Used to clear the alarm history. __ _ x: Alarm history clear selection 0: Disabled 1: Enabled When "Enabled" is set, the alarm history will be cleared at the next power-on. Once the alarm history is cleared, the setting becomes disabled automatically. _ _ x _: For manufacturer setting _ x _ _: For manufacturer setting x _ _ _: For manufacturer setting	0h 0h 0h
PC24	This parameter is not used. Do not change the value.	0000h	PC24	Forced stop deceleration time constant Set a deceleration time constant when you use the forced stop deceleration function. Set the time per ms from the rated speed to 0 r/min or 0 mm/s. Setting "0" will be 100 ms.  <p>[Pr. PC24]</p> <p>[Precautions]</p> <ul style="list-style-type: none"> ▪ If the servo motor torque is saturated at the maximum torque during forced stop deceleration because the set time is too short, the time to stop will be longer than the set time constant. ▪ [AL. 50 Overload alarm 1] or [AL. 51 Overload alarm 2] may occur during forced stop deceleration, depending on the set value. ▪ After an alarm that leads to a forced stop deceleration, if an alarm that does not lead to a forced stop deceleration occurs or if the control circuit power supply is cut, dynamic braking will start regardless of the deceleration time constant setting. ▪ Set a longer time than deceleration time of the controller. If a shorter time is set, [AL. 52 Error excessive] may occur. 	100

Part 4: Replacement of MR-J3W-_B with MR-J4W2-_B

MR-J3W-_B			MR-J4W2-_B		
No.	Name and function	Initial value	No.	Name and function	Initial value
PC27	This parameter is not used. Do not change the value.	0000h	PC27	Function selection C-9 This parameter is not available with MR-J4W2-0303B6 servo amplifiers.	
				___x: Selection of encoder pulse count polarity 0: Encoder pulse increasing direction in the servo motor CCW or positive direction 1: Encoder pulse decreasing direction in the servo motor CCW or positive direction	0h
				__x_: For manufacturer setting	0h
				_x__: For manufacturer setting	0h
				x___: For manufacturer setting	0h
PC29	This parameter is not used. Do not change the value.	0000h	PC29	Function selection C-B Select the POL reflection at torque control.	
				___x: For manufacturer setting	0h
				__x_: For manufacturer setting	0h
				_x__: For manufacturer setting	0h
				x___: POL reflection selection at torque control 0: Enabled 1: Disabled	0h
PC31	This parameter is not used. Do not change the value.	0000h	PC31	Vertical axis freefall prevention compensation amount Set the compensation amount of the vertical axis freefall prevention function. Set it per servo motor rotation amount. When a positive value is set, compensation is performed to the address increasing direction. When a negative value is set, compensation is performed to the address decreasing direction. The vertical axis freefall prevention function is performed when all of the following conditions are met. 1) Position control mode 2) The value of the parameter is other than "0". 3) The forced stop deceleration function is enabled. 4) Alarm occurs or EM2 turns off when the (linear) servo motor speed is zero speed or less. 5) MBR (Electromagnetic brake interlock) was enabled in [Pr. PD07] to [Pr. PD09], and the base circuit shut-off delay time was set in [Pr. PC02].	0

Part 4: Replacement of MR-J3W-_B with MR-J4W2-_B

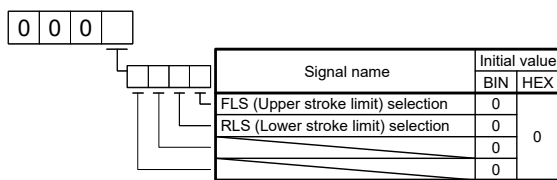
MR-J3W-_B			MR-J4W2-_B																							
No.	Name and function	Initial value	No.	Name and function	Initial value																					
PD02	This parameter is not used. Do not change the value.	0000h	PD02	Input signal automatic on selection 2																						
				<table border="1"> <tr> <td>___x (HEX)</td> <td>___x (BIN): FLS (Upper stroke limit) selection 0: Disabled 1: Enabled</td> <td rowspan="4">0h</td> </tr> <tr> <td></td> <td>__x_ (BIN) : RLS (Lower stroke limit) selection 0: Disabled 1: Enabled</td> </tr> <tr> <td></td> <td>_x__ (BIN) : For manufacturer setting</td> </tr> <tr> <td></td> <td>x___ (BIN) : For manufacturer setting</td> </tr> <tr> <td></td> <td>__x_ (HEX)</td> <td>For manufacturer setting</td> <td>0h</td> </tr> <tr> <td></td> <td>_x__ (HEX)</td> <td>For manufacturer setting</td> <td>0h</td> </tr> <tr> <td></td> <td>x___ (HEX)</td> <td>For manufacturer setting</td> <td>0h</td> </tr> </table>	___x (HEX)	___x (BIN): FLS (Upper stroke limit) selection 0: Disabled 1: Enabled	0h		__x_ (BIN) : RLS (Lower stroke limit) selection 0: Disabled 1: Enabled		_x__ (BIN) : For manufacturer setting		x___ (BIN) : For manufacturer setting		__x_ (HEX)	For manufacturer setting	0h		_x__ (HEX)	For manufacturer setting	0h		x___ (HEX)	For manufacturer setting	0h	
___x (HEX)	___x (BIN): FLS (Upper stroke limit) selection 0: Disabled 1: Enabled	0h																								
	__x_ (BIN) : RLS (Lower stroke limit) selection 0: Disabled 1: Enabled																									
	_x__ (BIN) : For manufacturer setting																									
	x___ (BIN) : For manufacturer setting																									
	__x_ (HEX)	For manufacturer setting	0h																							
	_x__ (HEX)	For manufacturer setting	0h																							
	x___ (HEX)	For manufacturer setting	0h																							
				<p>Convert the setting value into hexadecimal as follows.</p> <p>0 0 0</p>  <table border="1"> <thead> <tr> <th rowspan="2">Signal name</th> <th colspan="2">Initial value</th> </tr> <tr> <th>BIN</th> <th>HEX</th> </tr> </thead> <tbody> <tr> <td>FLS (Upper stroke limit) selection</td> <td>0</td> <td rowspan="3">0</td> </tr> <tr> <td>RLS (Lower stroke limit) selection</td> <td>0</td> </tr> <tr> <td></td> <td>0</td> </tr> </tbody> </table> <p>BIN 0: Disabled (Use for an external input signal.) BIN 1: Automatic on</p>	Signal name	Initial value		BIN	HEX	FLS (Upper stroke limit) selection	0	0	RLS (Lower stroke limit) selection	0		0										
Signal name	Initial value																									
	BIN	HEX																								
FLS (Upper stroke limit) selection	0	0																								
RLS (Lower stroke limit) selection	0																									
	0																									

Part 4: Replacement of MR-J3W-_B with MR-J4W2-_B

MR-J3W-_B			MR-J4W2-_B																																																																						
No.	Name and function	Initial value	No.	Name and function	Initial value																																																																				
PD07	<p>Output signal device selection 1 (CN3-12 for A-axis and CN3-25 for B-axis)</p> <p>Any input signal can be assigned to the CN3-12 pin for A-axis and CN3-25 pin for B-axis. In the factory setting, MBR-A/MBR-B is assigned.</p> <p>0 0 x x: Select the output device of the CN3-12 pin for Aaxis and CN3-25 pin for B-axis.</p> <p>The devices that can be assigned in each control mode are those that have the symbols indicated in the following table.</p> <table border="1"> <thead> <tr> <th>Setting</th> <th>Device</th> </tr> </thead> <tbody> <tr><td>00</td><td>Always OFF</td></tr> <tr><td>01</td><td>For manufacturer setting (Note 3)</td></tr> <tr><td>02</td><td>RD-A/RD-B</td></tr> <tr><td>03</td><td>ALM-A/ALM-B</td></tr> <tr><td>04</td><td>INP-A/INP-B (Note 1, 4)</td></tr> <tr><td>05</td><td>MBR-A/MBR-B</td></tr> <tr><td>06</td><td>For manufacturer setting (Note 3)</td></tr> <tr><td>07</td><td>TLC-A/TLC-B (Note 4)</td></tr> <tr><td>08</td><td>WNG-A/WNG-B</td></tr> <tr><td>09</td><td>BWNG-A/BWNG-B</td></tr> <tr><td>0A</td><td>SA-A/SA-B (Note 2)</td></tr> <tr><td>0B</td><td>VLC-A/VLC-B (Note 5)</td></tr> <tr><td>0C</td><td>ZSP-A/ZSP-B</td></tr> <tr><td>0D</td><td>For manufacturer setting (Note 3)</td></tr> <tr><td>0E</td><td>For manufacturer setting (Note 3)</td></tr> <tr><td>0F</td><td>CDPS-A/CDPS-B</td></tr> <tr><td>10</td><td>For manufacturer setting (Note 3)</td></tr> <tr><td>11</td><td>ABSV-A/ABSV-B (Note 1)</td></tr> <tr><td>12 to 1F</td><td>For manufacturer setting (Note 3)</td></tr> <tr><td>20 to 3F</td><td>For manufacturer setting (Note 3)</td></tr> </tbody> </table> <p>Note 1. Always off in the speed loop mode. 2. Always off in the position control mode and the torque loop mode. 3. For manufacturer setting. Never change this setting. 4. Always off in the torque loop mode. 5. Always off in the position control mode and the torque loop mode.</p>	Setting	Device	00	Always OFF	01	For manufacturer setting (Note 3)	02	RD-A/RD-B	03	ALM-A/ALM-B	04	INP-A/INP-B (Note 1, 4)	05	MBR-A/MBR-B	06	For manufacturer setting (Note 3)	07	TLC-A/TLC-B (Note 4)	08	WNG-A/WNG-B	09	BWNG-A/BWNG-B	0A	SA-A/SA-B (Note 2)	0B	VLC-A/VLC-B (Note 5)	0C	ZSP-A/ZSP-B	0D	For manufacturer setting (Note 3)	0E	For manufacturer setting (Note 3)	0F	CDPS-A/CDPS-B	10	For manufacturer setting (Note 3)	11	ABSV-A/ABSV-B (Note 1)	12 to 1F	For manufacturer setting (Note 3)	20 to 3F	For manufacturer setting (Note 3)	0005h	PD07	<p>Output device selection 1</p> <p>You can assign any output device to pins CN3-12 and CN3-25. In the initial setting, the following devices are assigned to the pins. CN3-12 pin: MBR-A (Electromagnetic brake interlock for A-axis) CN3-25 pin: MBR-B (Electromagnetic brake interlock for B-axis)</p> <p>__ x x: Device selection Refer to table 4.6 for settings.</p> <p>_ x __: For manufacturer setting</p> <p>x __ __: For manufacturer setting</p> <p>Table 4.6 Selectable output devices</p> <table border="1"> <thead> <tr> <th>Setting value</th> <th>Output device</th> </tr> </thead> <tbody> <tr><td>__ 0 0</td><td>Always off</td></tr> <tr><td>__ 0 2</td><td>RD (Ready)</td></tr> <tr><td>__ 0 3</td><td>ALM (Malfunction)</td></tr> <tr><td>__ 0 4</td><td>INP (In-position)</td></tr> <tr><td>__ 0 5</td><td>MBR (Electromagnetic brake interlock)</td></tr> <tr><td>__ 0 7</td><td>TLC (Limiting torque)</td></tr> <tr><td>__ 0 8</td><td>WNG (Warning)</td></tr> <tr><td>__ 0 9</td><td>BWNG (Battery warning)</td></tr> <tr><td>__ 0 A</td><td>SA (Speed reached)</td></tr> <tr><td>__ 0 C</td><td>ZSP (Zero speed detection)</td></tr> <tr><td>__ 0 F</td><td>CDPS (Variable gain selection)</td></tr> <tr><td>__ 1 1</td><td>ABSV (Absolute position undetermined)</td></tr> </tbody> </table>	Setting value	Output device	__ 0 0	Always off	__ 0 2	RD (Ready)	__ 0 3	ALM (Malfunction)	__ 0 4	INP (In-position)	__ 0 5	MBR (Electromagnetic brake interlock)	__ 0 7	TLC (Limiting torque)	__ 0 8	WNG (Warning)	__ 0 9	BWNG (Battery warning)	__ 0 A	SA (Speed reached)	__ 0 C	ZSP (Zero speed detection)	__ 0 F	CDPS (Variable gain selection)	__ 1 1	ABSV (Absolute position undetermined)	05h 0h 0h
Setting	Device																																																																								
00	Always OFF																																																																								
01	For manufacturer setting (Note 3)																																																																								
02	RD-A/RD-B																																																																								
03	ALM-A/ALM-B																																																																								
04	INP-A/INP-B (Note 1, 4)																																																																								
05	MBR-A/MBR-B																																																																								
06	For manufacturer setting (Note 3)																																																																								
07	TLC-A/TLC-B (Note 4)																																																																								
08	WNG-A/WNG-B																																																																								
09	BWNG-A/BWNG-B																																																																								
0A	SA-A/SA-B (Note 2)																																																																								
0B	VLC-A/VLC-B (Note 5)																																																																								
0C	ZSP-A/ZSP-B																																																																								
0D	For manufacturer setting (Note 3)																																																																								
0E	For manufacturer setting (Note 3)																																																																								
0F	CDPS-A/CDPS-B																																																																								
10	For manufacturer setting (Note 3)																																																																								
11	ABSV-A/ABSV-B (Note 1)																																																																								
12 to 1F	For manufacturer setting (Note 3)																																																																								
20 to 3F	For manufacturer setting (Note 3)																																																																								
Setting value	Output device																																																																								
__ 0 0	Always off																																																																								
__ 0 2	RD (Ready)																																																																								
__ 0 3	ALM (Malfunction)																																																																								
__ 0 4	INP (In-position)																																																																								
__ 0 5	MBR (Electromagnetic brake interlock)																																																																								
__ 0 7	TLC (Limiting torque)																																																																								
__ 0 8	WNG (Warning)																																																																								
__ 0 9	BWNG (Battery warning)																																																																								
__ 0 A	SA (Speed reached)																																																																								
__ 0 C	ZSP (Zero speed detection)																																																																								
__ 0 F	CDPS (Variable gain selection)																																																																								
__ 1 1	ABSV (Absolute position undetermined)																																																																								
PD08	<p>This parameter is not used. Do not change the value.</p>	0004h	PD08	<p>Output device selection 2</p> <p>You can assign any output device to the CN3-24 pin for each axis. CINP (AND in-position) is assigned to the all axes in the initial setting. The devices that can be assigned and the setting method are the same as in [Pr. PD07].</p> <p>__ x x: Device selection Refer to table 4.6 in [Pr. PD07] for settings.</p> <p>_ x __: All-axis output condition selection 0: AND output When all axes of A and B meet a condition, the device will be enabled (on or off). 1: OR output When all axes of A or B meet a condition, the device will be enabled (on or off). The digit will be enabled when "All axes (0 __ __)" is selected.</p> <p>x __ __: Output axis selection 0: All axes 1: A-axis 2: B-axis</p>	04h 0h 0h																																																																				

Part 4: Replacement of MR-J3W-_B with MR-J4W2-_B

MR-J3W-_B			MR-J4W2-_B		
No.	Name and function	Initial value	No.	Name and function	Initial value
PD08	This parameter is not used. Do not change the value.	0004h	PD08	Output device selection 2 You can assign any output device to the CN3-24 pin for each axis. CINP (AND in-position) is assigned to the all axes in the initial setting. The devices that can be assigned and the setting method are the same as in [Pr. PD07].	
			__ x x:	Device selection Refer to table 4.6 in [Pr. PD07] for settings.	04h
			_ x __:	All-axis output condition selection 0: AND output When all axes of A and B meet a condition, the device will be enabled (on or off). 1: OR output When all axes of A or B meet a condition, the device will be enabled (on or off). The digit will be enabled when "All axes (0 __ __)" is selected.	0h
			x __ __:	Output axis selection 0: All axes 1: A-axis 2: B-axis	0h
PD09	Output signal device selection 3 (CN3-11 for A-axis and CN3-24 for B-axis) Any input signal can be assigned to the CN3-11 pin for A-axis and CN3-24 pin for B-axis. In the factory setting, ALM-A/ALM-B is assigned. The devices that can be assigned and the setting method are the same as in [Pr. PD07]. 0 0 x x: Select the output device of the CN3-11 pin for Aaxis and CN3-24 pin for B-axis.	0003h	PD09	Output device selection 3 You can assign any output device to the CN3-11 pin for each axis. CALM (AND malfunction) is assigned to the all axes in the initial setting. The devices that can be assigned and the setting method are the same as in [Pr. PD07].	
			__ x x:	Device selection Refer to table 4.6 in [Pr. PD07] for settings.	03h
			_ x __:	All-axis output condition selection 0: AND output When all axes of A and B meet a condition, the device will be enabled (on or off). 1: OR output When each axis of A or B meet a condition, the device will be enabled (on or off). The digit will be enabled when "All axes (0 __ __)" is selected.	0h
			x __ __:	Output axis selection 0: All axes 1: A-axis 2: B-axis	0h

Part 4: Replacement of MR-J3W-_B with MR-J4W2-_B

MR-J3W-_B			MR-J4W2-_B													
No.	Name and function	Initial value	No.	Name and function	Initial value											
PD11	This parameter is not used. Do not change the value.	0004h	PD11	Input filter setting Select the input filter. ___x: Input signal filter selection Refer to the servo system controller instruction manual for the setting. If external input signal causes chattering due to noise, etc., input filter is used to suppress it. 0: None 1: 0.888 [ms] 2: 1.777 [ms] 3: 2.666 [ms] 4: 3.555 [ms]	4h											
				__x_ : For manufacturer setting	0h											
				_x__ : For manufacturer setting	0h											
				x___ : For manufacturer setting	0h											
PD12	This parameter is not used. Do not change the value.	0000h	PD12	Function selection D-1 ___x: For manufacturer setting	0h											
				__x_ : For manufacturer setting	0h											
				_x__ : For manufacturer setting	0h											
				x___ : Servo motor or linear servo motor thermistor enabled/disabled selection (Supported by servo amplifiers with software version A5 or later.) 0: Enabled 1: Disabled For servo motors or linear servo motor without thermistor, the setting will be disabled.	0h											
PD14	Function selection D-3 Set the ALM-A/ALM-B output signal at warning occurrence. 0 0 x 0: Selection of output device at warning occurrence Select the warning (WNG-A/WNG-B) and malfunction (ALM-A/ALM-B) output status at warning occurrence.	0000h	PD14	Function selection D-3 ___x: For manufacturer setting	0h											
				__x_ : Selection of output device at warning occurrence Select WNG (Warning) and ALM (Malfunction) output status at warning occurrence.	0h											
	<p style="text-align: center;">Output of Servo amplifier</p> <table border="1" style="width: 100%;"> <thead> <tr> <th>Setting</th> <th>Device status (Note)</th> </tr> </thead> <tbody> <tr> <td style="text-align: center;">0</td> <td> <div style="display: flex; justify-content: space-between;"> <div style="width: 45%;"> <p>WNG-A/WNG-B</p> <p>ALM-A/ALM-B</p> </div> <div style="width: 50%;"> </div> </div> <p style="text-align: center;">Warning occurrence</p> </td> </tr> <tr> <td style="text-align: center;">1</td> <td> <div style="display: flex; justify-content: space-between;"> <div style="width: 45%;"> <p>WNG-A/WNG-B</p> <p>ALM-A/ALM-B</p> </div> <div style="width: 50%;"> </div> </div> <p style="text-align: center;">Warning occurrence</p> </td> </tr> </tbody> </table> <p>Note. 0: OFF 1: ON</p>	Setting	Device status (Note)	0	<div style="display: flex; justify-content: space-between;"> <div style="width: 45%;"> <p>WNG-A/WNG-B</p> <p>ALM-A/ALM-B</p> </div> <div style="width: 50%;"> </div> </div> <p style="text-align: center;">Warning occurrence</p>	1	<div style="display: flex; justify-content: space-between;"> <div style="width: 45%;"> <p>WNG-A/WNG-B</p> <p>ALM-A/ALM-B</p> </div> <div style="width: 50%;"> </div> </div> <p style="text-align: center;">Warning occurrence</p>		<p style="text-align: center;">Servo amplifier output</p> <table border="1" style="width: 100%;"> <thead> <tr> <th>Setting value</th> <th>Device status (Note 1)</th> </tr> </thead> <tbody> <tr> <td style="text-align: center;">0</td> <td> <div style="display: flex; justify-content: space-between;"> <div style="width: 45%;"> <p>WNG</p> <p>ALM</p> </div> <div style="width: 50%;"> </div> </div> <p style="text-align: center;">Warning occurrence</p> </td> </tr> <tr> <td style="text-align: center;">1</td> <td> <div style="display: flex; justify-content: space-between;"> <div style="width: 45%;"> <p>WNG</p> <p>ALM</p> </div> <div style="width: 50%;"> </div> </div> <p style="text-align: center;">Warning occurrence (Note 2)</p> </td> </tr> </tbody> </table> <p>Note1. 0: OFF 1: ON 2. Although ALM is turned off upon occurrence of the warning, the forced stop deceleration is performed.</p>	Setting value	Device status (Note 1)	0	<div style="display: flex; justify-content: space-between;"> <div style="width: 45%;"> <p>WNG</p> <p>ALM</p> </div> <div style="width: 50%;"> </div> </div> <p style="text-align: center;">Warning occurrence</p>	1	<div style="display: flex; justify-content: space-between;"> <div style="width: 45%;"> <p>WNG</p> <p>ALM</p> </div> <div style="width: 50%;"> </div> </div> <p style="text-align: center;">Warning occurrence (Note 2)</p>	
Setting	Device status (Note)															
0	<div style="display: flex; justify-content: space-between;"> <div style="width: 45%;"> <p>WNG-A/WNG-B</p> <p>ALM-A/ALM-B</p> </div> <div style="width: 50%;"> </div> </div> <p style="text-align: center;">Warning occurrence</p>															
1	<div style="display: flex; justify-content: space-between;"> <div style="width: 45%;"> <p>WNG-A/WNG-B</p> <p>ALM-A/ALM-B</p> </div> <div style="width: 50%;"> </div> </div> <p style="text-align: center;">Warning occurrence</p>															
Setting value	Device status (Note 1)															
0	<div style="display: flex; justify-content: space-between;"> <div style="width: 45%;"> <p>WNG</p> <p>ALM</p> </div> <div style="width: 50%;"> </div> </div> <p style="text-align: center;">Warning occurrence</p>															
1	<div style="display: flex; justify-content: space-between;"> <div style="width: 45%;"> <p>WNG</p> <p>ALM</p> </div> <div style="width: 50%;"> </div> </div> <p style="text-align: center;">Warning occurrence (Note 2)</p>															
				_x__ : For manufacturer setting	0h											
				x___ : For manufacturer setting	0h											

Part 4: Replacement of MR-J3W-_B with MR-J4W2-_B

4. APPLICATION OF FUNCTIONS

POINT
<ul style="list-style-type: none">● Refer to "Part 8 Common Reference Material" for the application of functions.<ul style="list-style-type: none">▪ J3 compatibility mode <p>MR-J4W2-_B servo amplifiers have two operation mode: "J4 mode" is for using all functions with full performance and "J3 compatibility mode" for using the conventional MR-J3-_B_ servo amplifiers.</p>

Part 5

Review on Replacement of

MR-J3-DU_ with MR-J4-DU_

Part 5: Review on Replacement of MR-J3-DU_ with MR-J4-DU_

Part 5: Review on Replacement of MR-J3-DU_ with MR-J4-DU_

1. SUMMARY

The following explains the changes when the large capacity of 200 V (30 kW to 37 kW)/400 V (30 kW to 55 kW) of MELSERVO-J3 is replaced with MR-J4-DU_.

2. FUNCTIONS AND CONFIGURATION

2.1 Differences between MR-J3-DU_ and MR-J4-DU_

Item	MR-J3-DU_		MR-J4-DU_		Compatibility (Note)	Reference material/items	
Converter unit	200 V class	MR-J3-CR55K	200 V class	MR-CR55K	○	2.2 Combinations of the converter units, drive unit and servo motors.	
	400 V class	MR-J3-CR55K4	400 V class	MR-CR55K4			
Drive Unit	200 V class	MR-J3-DU30K_ MR-J3-DU37K_	200 V class	MR-J4-DU30K_ MR-J4-DU37K_	○		
	400 V class	MR-J3-DU30K_4 MR-J3-DU37K_4 MR-J3-DU45K_4 MR-J3-DU55K_4	400 V class	MR-J4-DU30K_4 MR-J4-DU37K_4 MR-J4-DU45K_4 MR-J4-DU55K_4			
Installation	A heat sink is attached outside the cabinet.		A heat sink is attached outside the cabinet.		○		3 Installation
Protection coordination connector	The termination connector is required (MR-J3-TM).		The termination connector is not required.		-		
Power consumption display	Not available		Available (Use converter unit [Pr. PA08] and [Pr. PA15] to set this value.)		-		
SEMI-F47 function selection	Not available		Available (Use converter unit [Pr. PA17] and [Pr. PA18], and drive unit [Pr. PA20] and [Pr. PF25] to set this value.)		-		
Regenerative resistor	Some regenerative options cannot be used for MR-J4.				-	7.5 Regenerative option	
Dynamic brakes	Some dynamic brakes cannot be used for MR-J4.				-	7.6 External dynamic brake	

Note. ○: Compatible

Part 5: Review on Replacement of MR-J3-DU_ with MR-J4-DU_

2.2 Combination of converter unit, drive unit, and servo motor

POINT			
<ul style="list-style-type: none"> ●MR-J3-_A_/MR-J3-_B_ cannot drive an HG motor. When the servo motor is replaced with an HG motor, simultaneous replacement withMR-J4-_A_/MR-J4-_B_ and an HG motor is necessary. ●When an "HA-LP motor " shown below is used, simultaneous replacement with "MR-J4-_A_/MR-J4-_B_ + HG motor is recommended. When an HG motor is adopted, the capacity of the servo amplifier needs to be changed. (Consider replacement, referring to "2.7 Comparison of Servo Motor Torque Characteristics" described in "Part 9: Review on Replacement of Motor".) 			
Existing device models		Replacement models for simultaneous replacement (example)	
Servo motor	Servo amplifier	Servo motor	Servo amplifier
HA-LP25K14	MR-J3-DU30K_4	HG-JR25K14 HG-JR25K14R-S_ (Note)	MR-J4-22K_4
HA-LP30K2(4)	MR-J3-DU30K_(4)	HG-JR22K1M(4) HG-JR22K1M(4)R-S_ (Note)	MR-J4-22K_(4)
HA-LP37K2(4)	MR-J3-DU37K_(4)	HG-JR30K1M(4) HG-JR30K1M(4)R-S_ (Note)	MR-J4-DU30K_(4)
HA-LP45K24	MR-J3-DU45K_4	HG-JR37K1M4 HG-JR37K1M4R-S_ (Note)	MR-J4-DU37K_4
HA-LP55K24	MR-J3-DU55K_4	HG-JR45K1M4 HG-JR45K1M4R-S_ (Note)	MR-J4-DU45K_4

Note. Only flanges and shaft ends have compatibility in mounting.
Please contact your local sales office regarding the servo motor model and its delivery, since it is developed upon receipt of order.

(1) MR-J3 series

(a) 200 V class

Converter unit	Servo amplifier	Servo motor		
		HA-LP_		
		1000 r/min	1500 r/min	2000 r/min
MR-J3-CR55K	MR-J3-DU30K_	30K1	30K1M	30K2
	MR-J3-DU37K_	37K1	37K1M	37K2

(b) 400 V class

Converter unit	Servo amplifier	Servo motor		
		HA-LP_		
		1000 r/min	1500 r/min	2000 r/min
MR-J3-CR55K4	MR-J3-DU30K_4	25K14 30K14	30K1M4	30K24
	MR-J3-DU37K_4	37K14	37K1M4	37K24
	MR-J3-DU45K_4		45K1M4	45K24
	MR-J3-DU55K_4		50K1M4	55K24

Part 5: Review on Replacement of MR-J3-DU_ with MR-J4-DU_

(2) MR-J4 series

(a) 200 V class

Converter unit	Drive unit	Servo motor	
		HG-JR_	
		1000 r/min series	1500 r/min series
MR-CR55K	MR-J4-DU30K_	30K1	30K1M
	MR-J4-DU37K_	37K1	37K1M

(b) 400 V class

Converter unit	Drive unit	Servo motor	
		HG-JR_	
		1000 r/min series	1500 r/min series
MR-CR55K4	MR-J4-DU30K_4	30K14	30K1M4
	MR-J4-DU37K_4	37K14	37K1M4
	MR-J4-DU45K_4		45K1M4
	MR-J4-DU55K_4		55K1M4

Part 5: Review on Replacement of MR-J3-DU_ with MR-J4-DU_

2.3 Configuration including peripheral equipment

(1) MR-J3-DU_

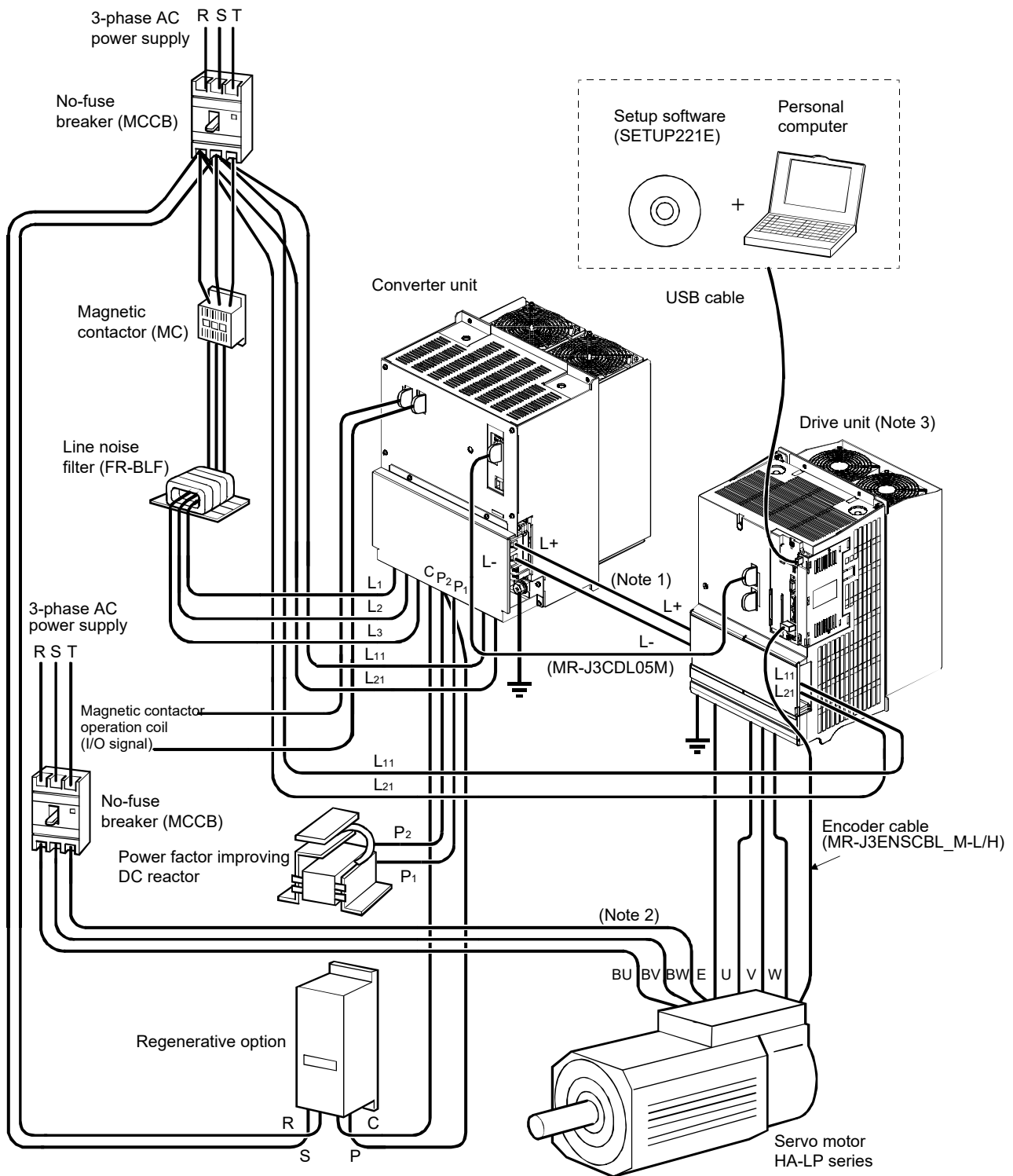

- Note 1. The L+ and L- connection conductors used to connect a converter unit to a drive unit are standard accessories. The converter unit is attached to the drive unit actually. (Refer to Chapter 3.)
- Note 2. The power supply of the servo motor cooling fan differs depending on the capacity of a servo motor. Refer to, "HG-MR/HG-KR/HG-SR/HG-JR/HG-RR/HG-UR/HG-AK Servo Motor Instruction Manual (Vol. 3)".
- Note 3. For MR-J3-DU30KB4 or MR-J3-DU37KB4.

Part 5: Review on Replacement of MR-J3-DU_ with MR-J4-DU_

(2) MR-J4-DU_

The diagram shows MR-J4-DU30KB4 and MR-J4-DU37KB4. The interface connection of MR-J4-DU_ is the same as that of MR-J4-_. Refer to each servo amplifier instruction manual.

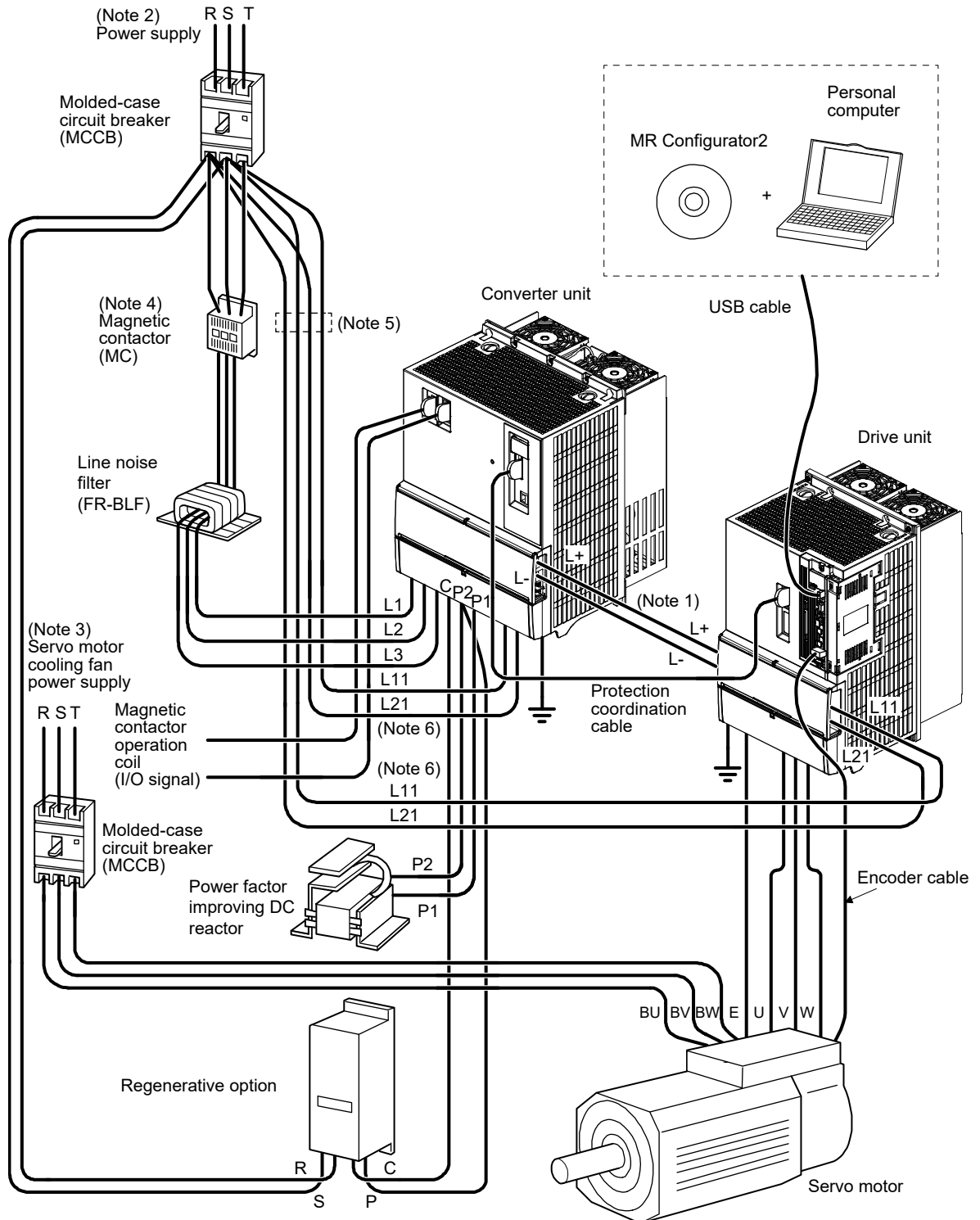

- Note
1. The bus bars on L+ and L- for connecting the converter unit to the drive unit are standard accessories. In the actual connection, the converter unit is closely mounted to the drive unit.
 2. For the power supply specifications, refer to "Part 8: Common Reference Material".
 3. For specifications of the cooling fan power supply, refer to "HG-MR/HG-KR/HG-SR/HG-JR/HG-RR/HG-UR/HG-AK Servo Motor Instruction Manual (Vol. 3)".
 4. An bus voltage may drop, depending on the main circuit voltage and operation pattern, causing a dynamic brake deceleration during a forced stop deceleration. When dynamic brake deceleration is not required, delay the time to turn off the magnetic contactor.
 5. Install an overcurrent protection device (molded-case circuit breaker, fuse, or others) to protect the branch circuit. (Refer to section 7.3.)
 6. The control circuit power supply (L11/L21) can be connected by passing wiring. Refer to section 7.2 for the wire size and the selection of the overcurrent protection device.

Part 5: Review on Replacement of MR-J3-DU_ with MR-J4-DU_

3. INSTALLATION

When using heat generating equipment such as the regenerative option, install them with full consideration of heat generation so that the converter unit and drive unit is not affected.

Install the converter unit and drive unit on a perpendicular wall in the correct vertical direction.

3.1 Installation direction and clearances

CAUTION

- The equipment must be installed in the specified direction. Otherwise, it may cause a malfunction.
- Maintain specified clearances between the converter unit/drive unit and the inner surfaces of a control cabinet or other equipment. Otherwise, it may cause a malfunction.

(1) MR-J3-DU_ (a) Installation

POINT

- Make sure to connect a drive unit to the right side of a converter unit as shown in the diagram.

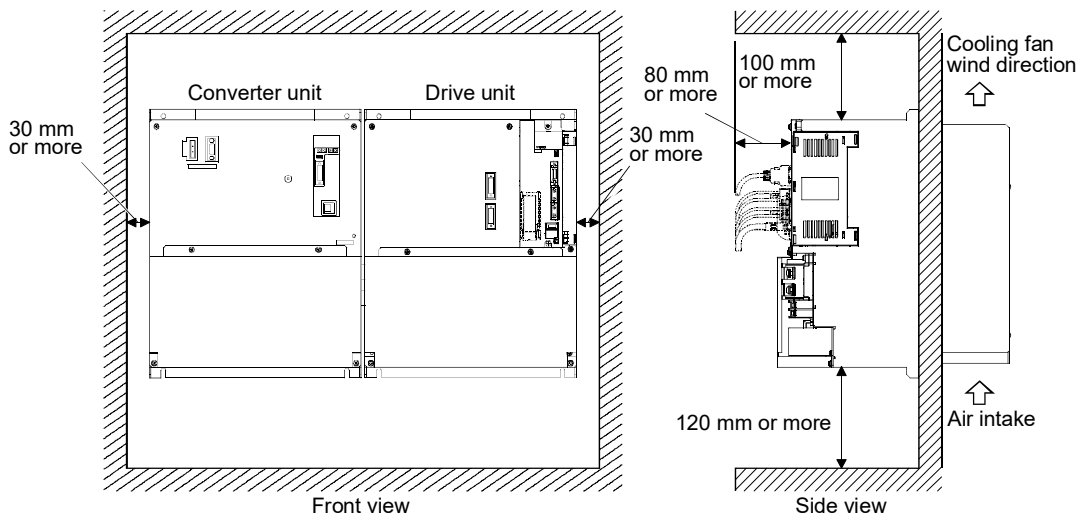

(b) Mounting dimensional diagram

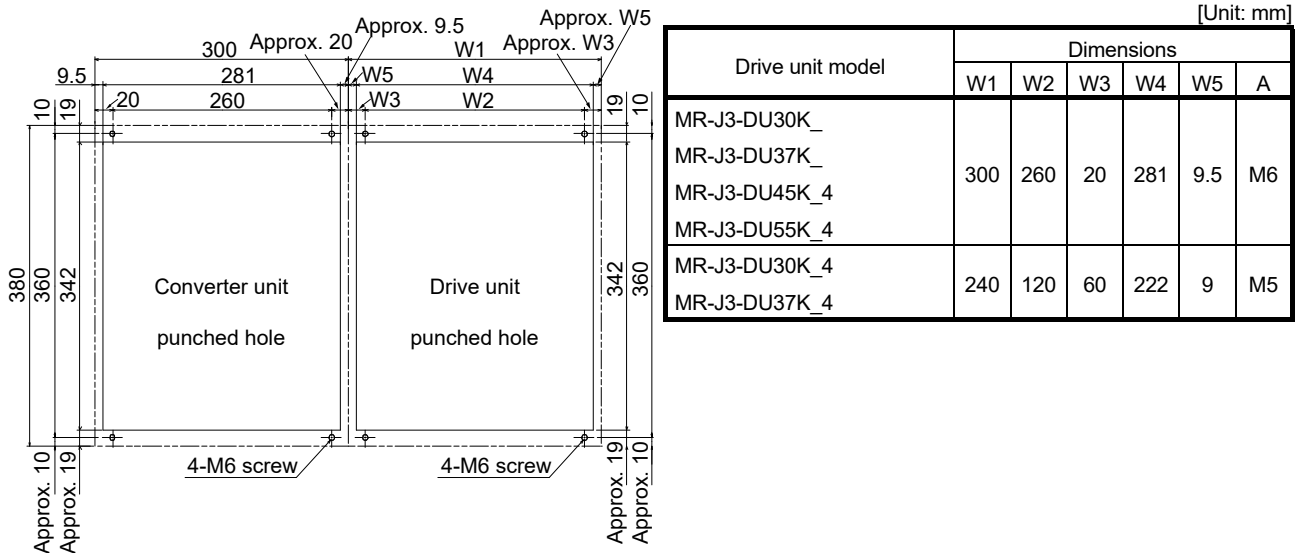

Part 5: Review on Replacement of MR-J3-DU_ with MR-J4-DU_

(2) MR-J4-DU_ (a) Installation

POINT
 ● Make sure to connect a drive unit to the right side of a converter unit as shown in the diagram.

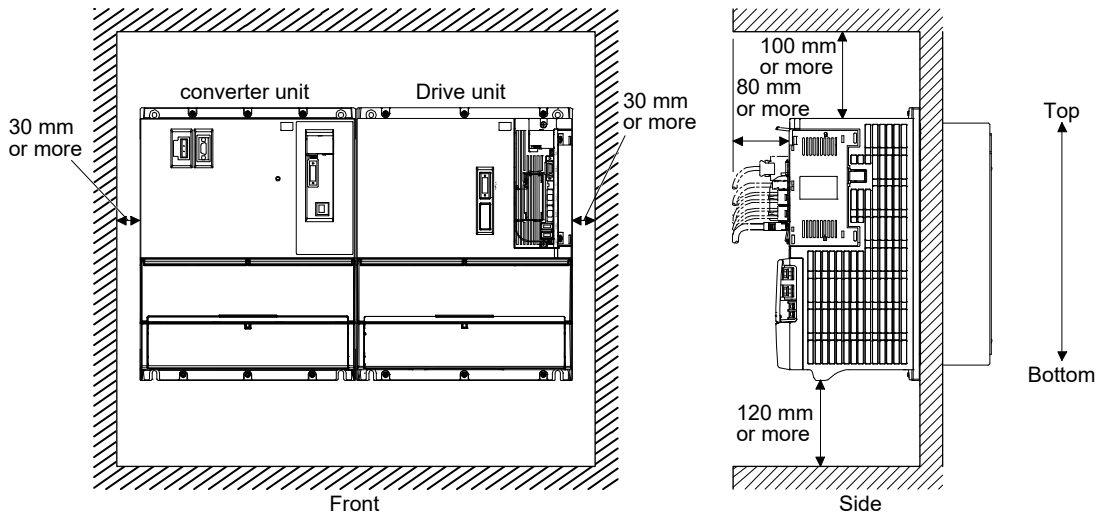

(b) Mounting hole process drawing

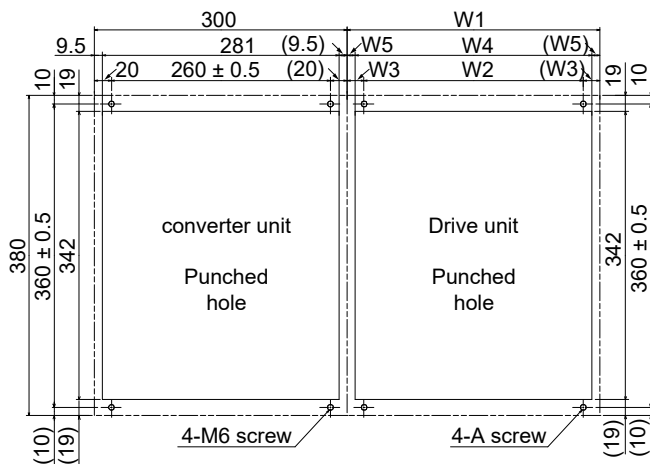

Converter unit Drive unit	Variable dimensions [mm]					Screw size
	W1	W2	W3	W4	W5	A
MR-J4-DU30K_ MR-J4-DU37K_ MR-J4-DU45K_4 MR-J4-DU55K_4	300	260 ± 0.5	20	281	9.5	M6
MR-J4-DU30K_4 MR-J4-DU37K_4	240	120 ± 0.5	60	222	9	M5

Part 5: Review on Replacement of MR-J3-DU_ with MR-J4-DU_

3.2 Magnetic contactor control connector (CNP1)



CAUTION

● Always connect the magnetic contactor wiring connector to the converter unit. If the connector is not connected, an electric shock may occur since CNP1-1 and L11 are always conducting.

By enabling magnetic contactor drive output, the main circuit power supply can be shut off automatically when an alarm occurs in the converter unit or the drive unit.

To enable magnetic contactor drive output, set [Pr. PA02] of the converter unit to "___ 1" (initial value).

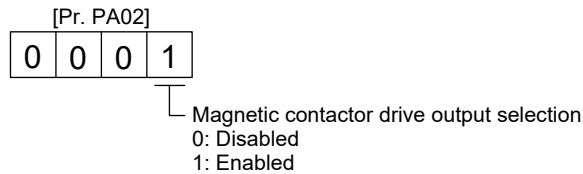

(1) When magnetic contactor drive output is enabled

To control the magnetic contactor, connect the magnetic contactor control connector (CNP1) to the coil of the magnetic contactor.

Internal connection diagram of CNP1

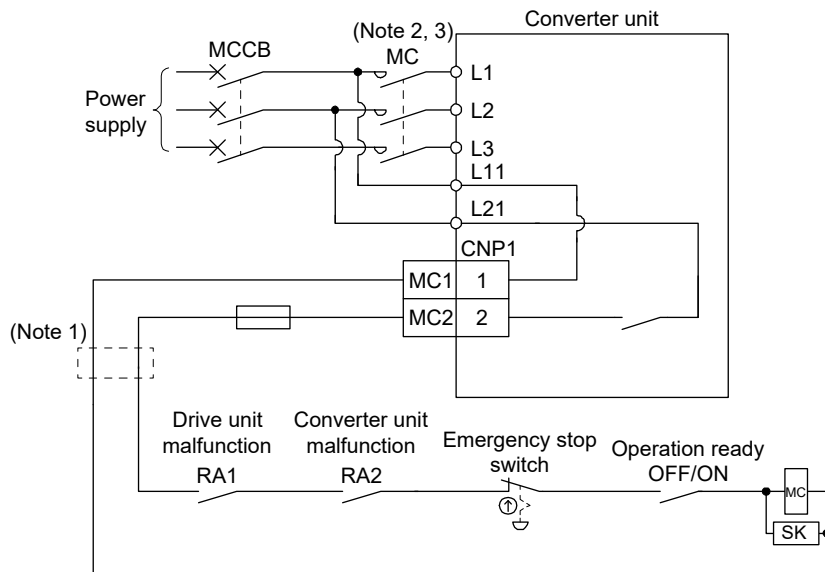

- Note 1. A step-down transformer is required when coil voltage of the magnetic contactor is 200 V class, and the converter unit and the drive unit are 400 V class.
- Note 2. The bus voltage decreases depending on the main circuit voltage and operation pattern, which may cause the forced stop deceleration to shift to the dynamic brake deceleration. When dynamic brake deceleration is not required, delay the time to turn off the magnetic contactor.
- Note 3. When the voltage between L11 and L21 drops due to an instantaneous power failure and others, the magnetic contactor is turned off.

Part 5: Review on Replacement of MR-J3-DU_ with MR-J4-DU_

When the converter unit receives a start command from the drive unit, CNP1-2 and L21 are shorted, and the control circuit power is supplied to the magnetic contactor. When the control circuit power is supplied, the magnetic contactor is turned on, and the main circuit power is supplied to the converter unit.

In the following cases, CNP1-2 and L21 in the converter unit are opened, and the main circuit power supply is automatically shut off.

- (a) An alarm has occurred in the converter unit.
 - (b) An alarm has occurred in the drive unit.
 - (c) The EM1 (forced stop) of the converter unit was turned off.
 - (d) [AL. 95 STO warning] has occurred in the drive unit (J4 series).
- (2) When magnetic contactor drive output is disabled
The main circuit power supply is not automatically shut off even when an alarm occurs in the converter unit or the drive unit. Therefore, configure an external circuit to shut off the main circuit power supply when detecting an alarm.

Part 5: Review on Replacement of MR-J3-DU_ with MR-J4-DU_

4. SIGNALS AND WIRING

4.1 Comparison of standard connection diagrams

⚠ WARNING ● Insulate the connections of the power supply terminals. Otherwise, an electric shock may occur.

⚠ CAUTION

- Be sure to connect a magnetic contactor between the power supply and the main circuit power supply (L1/L2/L3) of the power regeneration converter unit, in order to configure a circuit that shuts off the power supply by the magnetic contactor. If the magnetic contactor is not connected, a large current keeps flowing and may cause a fire when the power regeneration converter unit or the drive unit malfunctions.
- Use ALM (Malfunction) to shut the power off. Not doing so may cause a fire when the power regeneration converter unit malfunctions and causes the AC reactor to overheat.
- Connect the drive unit power outputs (U/V/W) to the servo motor power inputs (U/V/W) directly. Do not connect a magnetic contactor and others between them. Otherwise, it may cause a malfunction.
- Do not connect the servo motor directly to the 3-phase 200 V power supply or the 3-phase 400 V power supply. Otherwise a malfunction may be caused.
- During power-on, do not open or close the motor power line. Otherwise, a malfunction or faulty may occur.

POINT

- When using an external dynamic brake, refer to each servo amplifier instruction manual.

4.1.1 When magnetic contactor drive output is enabled (factory setting)

POINT

- The converter unit controls the magnetic contactor.
- Connect the converter unit and the drive unit with MR-J3CDL05M protection coordination cable. (For MR-J3-DU_, always connect a terminal connector (MR-J3-TM) as well.)
- Always turn on or off the control circuit power supplies of the converter unit and the drive unit simultaneously.

Part 5: Review on Replacement of MR-J3-DU_ with MR-J4-DU_

(1) 200 V class

(a) MR-J3-DU_A/MR-J4-DU_A

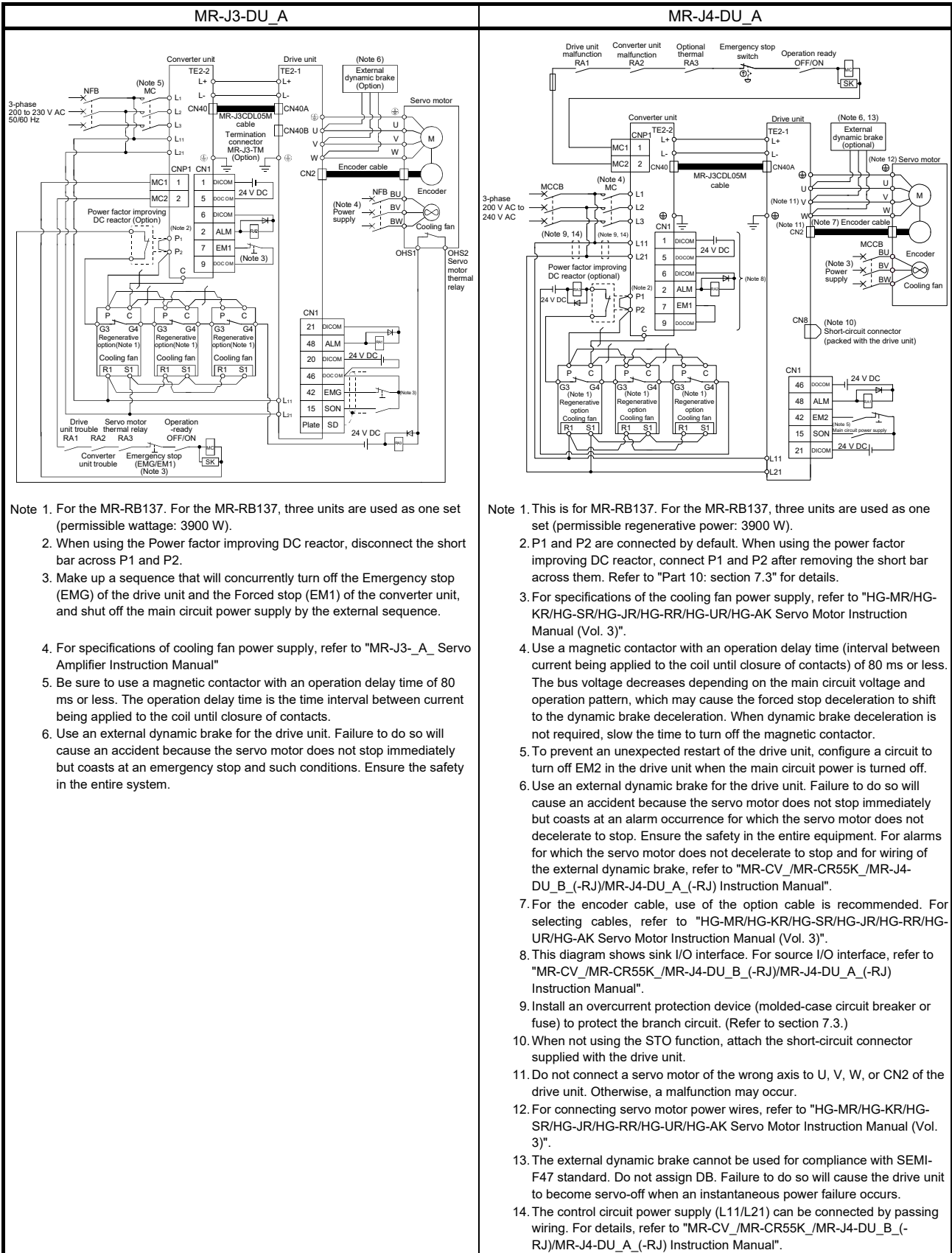

Part 5: Review on Replacement of MR-J3-DU_ with MR-J4-DU_

(b) MR-J3-DU_B/MR-J4-DU_B

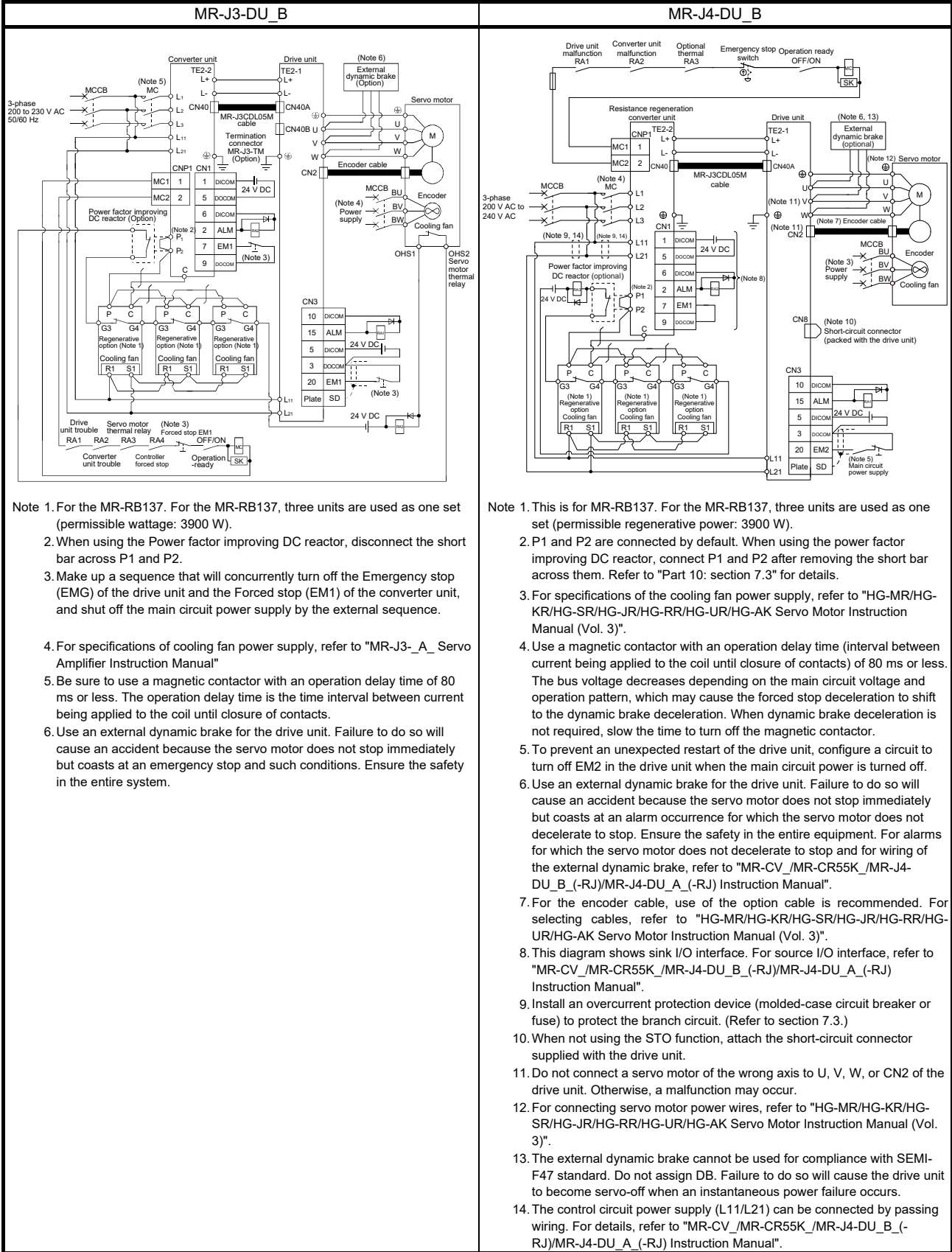

- Note 1. For the MR-RB137. For the MR-RB137, three units are used as one set (permissible wattage: 3900 W).
- When using the Power factor improving DC reactor, disconnect the short bar across P1 and P2.
 - Make up a sequence that will concurrently turn off the Emergency stop (EMG) of the drive unit and the Forced stop (EM1) of the converter unit, and shut off the main circuit power supply by the external sequence.
 - For specifications of cooling fan power supply, refer to "MR-J3-_ Servo Amplifier Instruction Manual"
 - Be sure to use a magnetic contactor with an operation delay time of 80 ms or less. The operation delay time is the time interval between current being applied to the coil until closure of contacts.
 - Use an external dynamic brake for the drive unit. Failure to do so will cause an accident because the servo motor does not stop immediately but coasts at an emergency stop and such conditions. Ensure the safety in the entire system.

- Note 1. This is for MR-RB137. For the MR-RB137, three units are used as one set (permissible regenerative power: 3900 W).
- P1 and P2 are connected by default. When using the power factor improving DC reactor, connect P1 and P2 after removing the short bar across them. Refer to "Part 10: section 7.3" for details.
 - For specifications of the cooling fan power supply, refer to "HG-MR/HG-KR/HG-SR/HG-JR/HG-RR/HG-UR/HG-AK Servo Motor Instruction Manual (Vol. 3)".
 - Use a magnetic contactor with an operation delay time (interval between current being applied to the coil until closure of contacts) of 80 ms or less. The bus voltage decreases depending on the main circuit voltage and operation pattern, which may cause the forced stop deceleration to shift to the dynamic brake deceleration. When dynamic brake deceleration is not required, slow the time to turn off the magnetic contactor.
 - To prevent an unexpected restart of the drive unit, configure a circuit to turn off EM2 in the drive unit when the main circuit power is turned off.
 - Use an external dynamic brake for the drive unit. Failure to do so will cause an accident because the servo motor does not stop immediately but coasts at an alarm occurrence for which the servo motor does not decelerate to stop. Ensure the safety in the entire equipment. For alarms for which the servo motor does not decelerate to stop and for wiring of the external dynamic brake, refer to "MR-CV_/MR-CR55K_/MR-J4-DU_B_(-RJ)/MR-J4-DU_A_(-RJ) Instruction Manual".
 - For the encoder cable, use of the option cable is recommended. For selecting cables, refer to "HG-MR/HG-KR/HG-SR/HG-JR/HG-RR/HG-UR/HG-AK Servo Motor Instruction Manual (Vol. 3)".
 - This diagram shows sink I/O interface. For source I/O interface, refer to "MR-CV_/MR-CR55K_/MR-J4-DU_B_(-RJ)/MR-J4-DU_A_(-RJ) Instruction Manual".
 - Install an overcurrent protection device (molded-case circuit breaker or fuse) to protect the branch circuit. (Refer to section 7.3.)
 - When not using the STO function, attach the short-circuit connector supplied with the drive unit.
 - Do not connect a servo motor of the wrong axis to U, V, W, or CN2 of the drive unit. Otherwise, a malfunction may occur.
 - For connecting servo motor power wires, refer to "HG-MR/HG-KR/HG-SR/HG-JR/HG-RR/HG-UR/HG-AK Servo Motor Instruction Manual (Vol. 3)".
 - The external dynamic brake cannot be used for compliance with SEMI-F47 standard. Do not assign DB. Failure to do so will cause the drive unit to become servo-off when an instantaneous power failure occurs.
 - The control circuit power supply (L11/L21) can be connected by passing wiring. For details, refer to "MR-CV_/MR-CR55K_/MR-J4-DU_B_(-RJ)/MR-J4-DU_A_(-RJ) Instruction Manual".

Part 5: Review on Replacement of MR-J3-DU_ with MR-J4-DU_

- (2) 400 V class
- (a) MR-J3-DU_A4/MR-J4-DU_A4

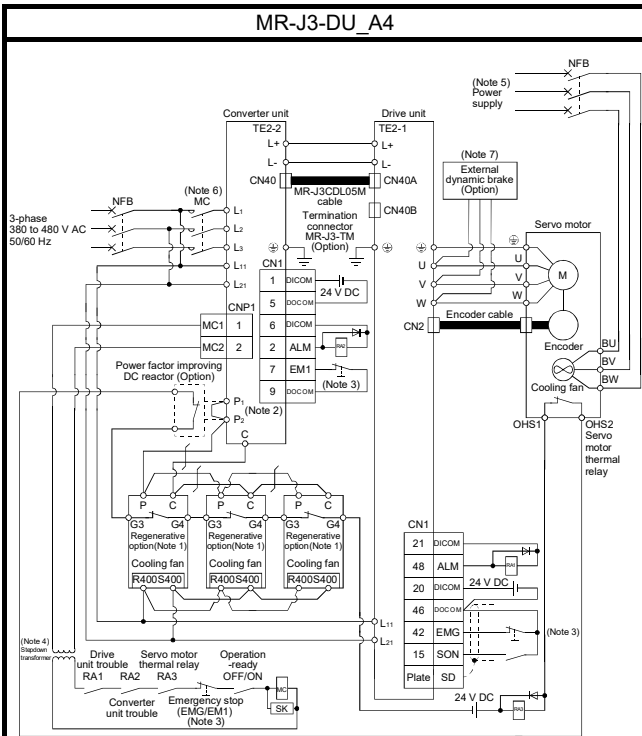

- Note 1. For the MR-RB138-4. For the MR-RB138-4, three units are used as one set (permissible wattage: 3900 W).
2. When using the Power factor improving DC reactor, disconnect the short bar across P1 and P2.
 3. Make up a sequence that will concurrently turn off the Emergency stop (EMG) of the drive unit and the Forced stop (EM1) of the converter unit, and shut off the main circuit power supply by the external sequence.
 4. Stepdown transformer is required for coil voltage of magnetic contactor more than 200V class.
 5. For specifications of cooling fan power supply, refer to "MR-J3_A_Servo Amplifier Instruction Manual".
 6. Be sure to use a magnetic contactor with an operation delay time of 80 ms or less. The operation delay time is the time interval between current being applied to the coil until closure of contacts.
 7. Use an external dynamic brake for the drive unit. Failure to do so will cause an accident because the servo motor does not stop immediately but coasts at an emergency stop and such conditions. Ensure the safety in the entire system.

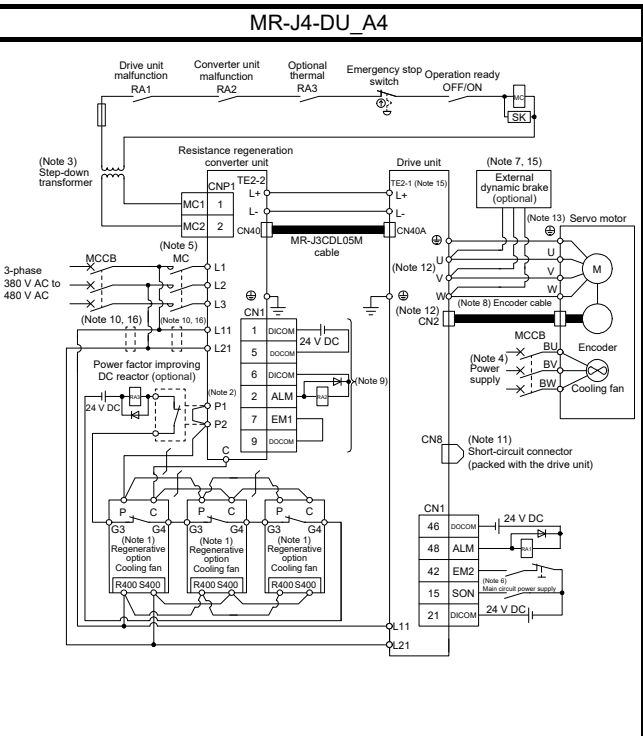

- Note 1. This is for MR-RB13V-4. For the MR-RB13V-4, three units are used as one set (permissible regenerative power: 3900 W).
2. P1 and P2 are connected by default. When using the power factor improving DC reactor, connect P1 and P2 after removing the short bar across them. Refer to "Part 10: section 7.3" for details.
 3. A step-down transformer is required when the coil voltage of the magnetic contactor is 200 V class.
 4. For specifications of the cooling fan power supply, refer to "HG-MR/HG-KR/HG-SR/HG-JR/HG-RR/HG-UR/HG-AK Servo Motor Instruction Manual (Vol. 3)".
 5. Use a magnetic contactor with an operation delay time (interval between current being applied to the coil until closure of contacts) of 80 ms or less. The bus voltage decreases depending on the main circuit voltage and operation pattern, which may cause the forced stop deceleration to shift to the dynamic brake deceleration. When dynamic brake deceleration is not required, slow the time to turn off the magnetic contactor.
 6. To prevent an unexpected restart of the drive unit, configure a circuit to turn off EM2 in the drive unit when the main circuit power is turned off.
 7. Use an external dynamic brake for the drive unit. Failure to do so will cause an accident because the servo motor does not stop immediately but coasts at an alarm occurrence for which the servo motor does not decelerate to stop. Ensure the safety in the entire equipment. For alarms for which the servo motor does not decelerate to stop and for wiring of the external dynamic brake, refer to "MR-CV_/MR-CR55K_/MR-J4-DU_B_(-RJ)/MR-J4-DU_A_(-RJ) Instruction Manual".
 8. For the encoder cable, use of the option cable is recommended. For selecting cables, refer to "HG-MR/HG-KR/HG-SR/HG-JR/HG-RR/HG-UR/HG-AK Servo Motor Instruction Manual (Vol. 3)".
 9. This diagram shows sink I/O interface. For source I/O interface, refer to "MR-CV_/MR-CR55K_/MR-J4-DU_B_(-RJ)/MR-J4-DU_A_(-RJ) Instruction Manual".
 10. Install an overcurrent protection device (molded-case circuit breaker or fuse) to protect the branch circuit. (Refer to section 7.3.)
 11. When not using the STO function, attach the short-circuit connector supplied with the drive unit.
 12. Do not connect the servo motor of a wrong axis to U, V, W, or CN2 of the drive unit. Otherwise, a malfunction may occur.
 13. For connecting servo motor power wires, refer to "HG-MR/HG-KR/HG-SR/HG-JR/HG-RR/HG-UR/HG-AK Servo Motor Instruction Manual (Vol. 3)".
 14. For the MR-J4-DU30K_4 and MR-J4-DU37K_4, the terminal block is TE2.
 15. The external dynamic brake cannot be used for compliance with SEMI-F47 standard. Do not assign DB. Failure to do so will cause the drive unit to become servo-off when an instantaneous power failure occurs.
 16. The control circuit power supply (L11/L21) can be connected by passing wiring. For details, refer to "MR-CV_/MR-CR55K_/MR-J4-DU_B_(-RJ)/MR-J4-DU_A_(-RJ) Instruction Manual".

Part 5: Review on Replacement of MR-J3-DU_ with MR-J4-DU_

(b) MR-J3-DU_B4/MR-J4-DU_B4

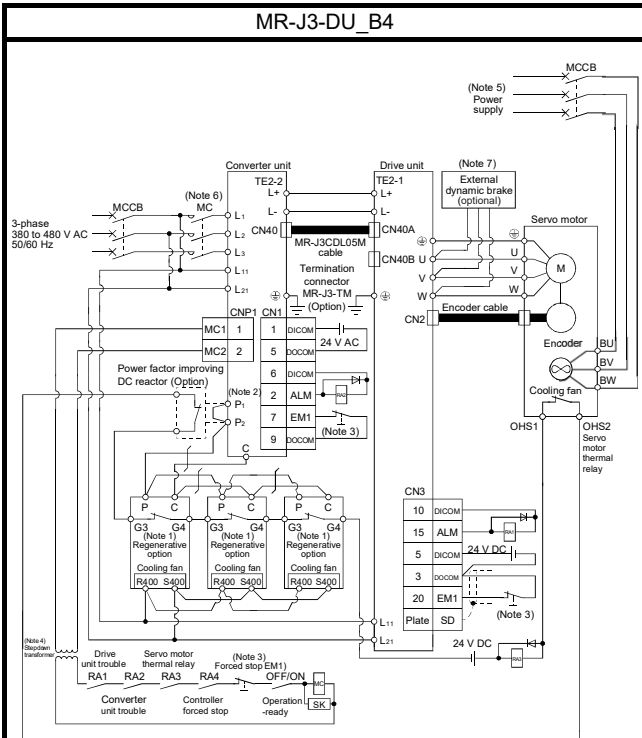

- Note 1. For the MR-RB138-4. For the MR-RB138-4, three units are used as one set (permissible wattage: 3900 W).
- When using the Power factor improving DC reactor, disconnect the short bar across P1 and P2.
- Make up a sequence that will concurrently turn off the Emergency stop (EM1) of the drive unit and the Forced stop (EM1) of the converter unit, and shut off the main circuit power supply by the external sequence.
- Stepdown transformer is required for coil voltage of magnetic contactor more than 200V class.
- For specifications of cooling fan power supply, refer to "MR-J3-_A_Servo Amplifier Instruction Manual".
- Be sure to use a magnetic contactor with an operation delay time of 80 ms or less. The operation delay time is the time interval between current being applied to the coil until closure of contacts.
- Use an external dynamic brake for the drive unit. Failure to do so will cause an accident because the servo motor does not stop immediately but coasts at an emergency stop and such conditions. Ensure the safety in the entire system.

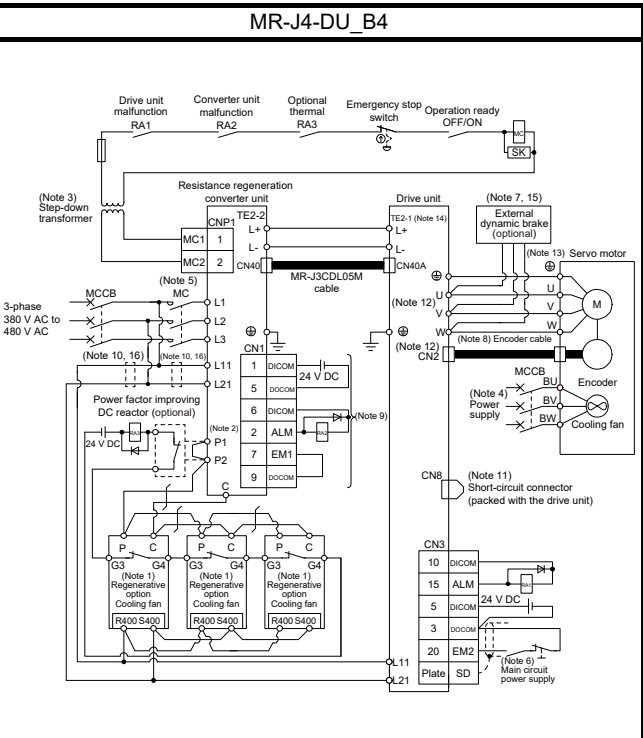

- Note 1. This is for MR-RB13V-4. For the MR-RB13V-4, three units are used as one set (permissible regenerative power: 3900 W).
- P1 and P2 are connected by default. When using the power factor improving DC reactor, connect P1 and P2 after removing the short bar across them. Refer to "Part 10: section 7.3" for details.
- A step-down transformer is required when the coil voltage of the magnetic contactor is 200 V class.
- For specifications of the cooling fan power supply, refer to "HG-MR/HG-KR/HG-SR/HG-JR/HG-RR/HG-UR/HG-AK Servo Motor Instruction Manual (Vol. 3)".
- Use a magnetic contactor with an operation delay time (interval between current being applied to the coil until closure of contacts) of 80 ms or less. The bus voltage decreases depending on the main circuit voltage and operation pattern, which may cause the forced stop deceleration to shift to the dynamic brake deceleration. When dynamic brake deceleration is not required, slow the time to turn off the magnetic contactor.
- To prevent an unexpected restart of the drive unit, configure a circuit to turn off EM2 in the drive unit when the main circuit power is turned off.
- Use an external dynamic brake for the drive unit. Failure to do so will cause an accident because the servo motor does not stop immediately but coasts at an alarm occurrence for which the servo motor does not decelerate to stop. Ensure the safety in the entire equipment. For alarms for which the servo motor does not decelerate to stop and for wiring of the external dynamic brake, refer to "MR-CV_/MR-CR55K_/MR-J4-DU_B_(-RJ)/MR-J4-DU_A_(-RJ) Instruction Manual".
- For the encoder cable, use of the option cable is recommended. For selecting cables, refer to "HG-MR/HG-KR/HG-SR/HG-JR/HG-RR/HG-UR/HG-AK Servo Motor Instruction Manual (Vol. 3)".
- This diagram shows sink I/O interface. For source I/O interface, refer to "MR-CV_/MR-CR55K_/MR-J4-DU_B_(-RJ)/MR-J4-DU_A_(-RJ) Instruction Manual".
- Install an overcurrent protection device (molded-case circuit breaker or fuse) to protect the branch circuit. (Refer to section 7.3.)
- When not using the STO function, attach the short-circuit connector supplied with the drive unit.
- Do not connect the servo motor of a wrong axis to U, V, W, or CN2 of the drive unit. Otherwise, a malfunction may occur.
- For connecting servo motor power wires, refer to "HG-MR/HG-KR/HG-SR/HG-JR/HG-RR/HG-UR/HG-AK Servo Motor Instruction Manual (Vol. 3)".
- For the MR-J4-DU30K_4 and MR-J4-DU37K_4, the terminal block is TE2.
- The external dynamic brake cannot be used for compliance with SEMI-F47 standard. Do not assign DB. Failure to do so will cause the drive unit to become servo-off when an instantaneous power failure occurs.
- The control circuit power supply (L11/L21) can be connected by passing wiring. For details, refer to "MR-CV_/MR-CR55K_/MR-J4-DU_B_(-RJ)/MR-J4-DU_A_(-RJ) Instruction Manual".

Part 5: Review on Replacement of MR-J3-DU_ with MR-J4-DU_

4.1.2 When magnetic contactor control connector (CNP1) is made invalid

POINT	
	<ul style="list-style-type: none">● When making CNP1 invalid, set "0000" in [Pr. PA02]. (Refer to Part: 5).● Always connect a protection coordination cable (MR-J3CDL05M). (For MR-J3-DU_, always connect a terminal connector (MR-J3-TM) as well.) When they are not connected properly, the servo-on may not be turned on.● Always turn on or off the control circuit power supplies of the converter unit and the drive unit simultaneously.

Part 5: Review on Replacement of MR-J3-DU_ with MR-J4-DU_

(b) MR-J3-DU_B/MR-J4-DU_B

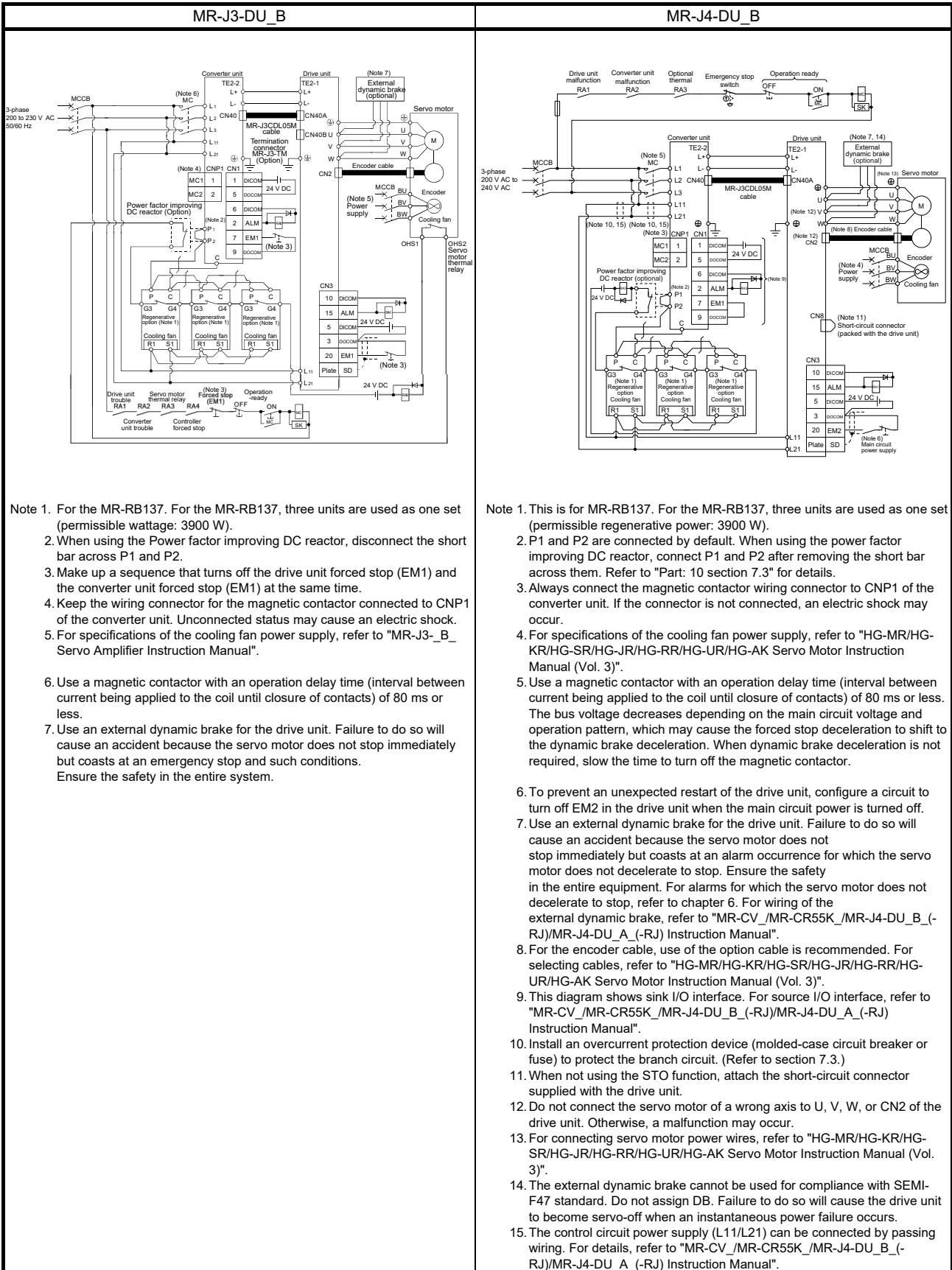

- Note 1. For the MR-RB137. For the MR-RB137, three units are used as one set (permissible wattage: 3900 W).
- When using the Power factor improving DC reactor, disconnect the short bar across P1 and P2.
 - Make up a sequence that turns off the drive unit forced stop (EM1) and the converter unit forced stop (EM1) at the same time.
 - Keep the wiring connector for the magnetic contactor connected to CNP1 of the converter unit. Unconnected status may cause an electric shock.
 - For specifications of the cooling fan power supply, refer to "MR-J3-_B_Servo Amplifier Instruction Manual".
 - Use a magnetic contactor with an operation delay time (interval between current being applied to the coil until closure of contacts) of 80 ms or less.
 - Use an external dynamic brake for the drive unit. Failure to do so will cause an accident because the servo motor does not stop immediately but coasts at an emergency stop and such conditions. Ensure the safety in the entire system.

- Note 1. This is for MR-RB137. For the MR-RB137, three units are used as one set (permissible regenerative power: 3900 W).
- P1 and P2 are connected by default. When using the power factor improving DC reactor, connect P1 and P2 after removing the short bar across them. Refer to "Part: 10 section 7.3" for details.
 - Always connect the magnetic contactor wiring connector to CNP1 of the converter unit. If the connector is not connected, an electric shock may occur.
 - For specifications of the cooling fan power supply, refer to "HG-MR/HG-KR/HG-SR/HG-JR/HG-RR/HG-UR/HG-AK Servo Motor Instruction Manual (Vol. 3)".
 - Use a magnetic contactor with an operation delay time (interval between current being applied to the coil until closure of contacts) of 80 ms or less. The bus voltage decreases depending on the main circuit voltage and operation pattern, which may cause the forced stop deceleration to shift to the dynamic brake deceleration. When dynamic brake deceleration is not required, slow the time to turn off the magnetic contactor.
 - To prevent an unexpected restart of the drive unit, configure a circuit to turn off EM2 in the drive unit when the main circuit power is turned off.
 - Use an external dynamic brake for the drive unit. Failure to do so will cause an accident because the servo motor does not stop immediately but coasts at an alarm occurrence for which the servo motor does not decelerate to stop. Ensure the safety in the entire equipment. For alarms for which the servo motor does not decelerate to stop, refer to chapter 6. For wiring of the external dynamic brake, refer to "MR-CV_/MR-CR55K_/MR-J4-DU_B_(-RJ)/MR-J4-DU_A_(-RJ) Instruction Manual".
 - For the encoder cable, use of the option cable is recommended. For selecting cables, refer to "HG-MR/HG-KR/HG-SR/HG-JR/HG-RR/HG-UR/HG-AK Servo Motor Instruction Manual (Vol. 3)".
 - This diagram shows sink I/O interface. For source I/O interface, refer to "MR-CV_/MR-CR55K_/MR-J4-DU_B_(-RJ)/MR-J4-DU_A_(-RJ) Instruction Manual".
 - Install an overcurrent protection device (molded-case circuit breaker or fuse) to protect the branch circuit. (Refer to section 7.3.)
 - When not using the STO function, attach the short-circuit connector supplied with the drive unit.
 - Do not connect the servo motor of a wrong axis to U, V, W, or CN2 of the drive unit. Otherwise, a malfunction may occur.
 - For connecting servo motor power wires, refer to "HG-MR/HG-KR/HG-SR/HG-JR/HG-RR/HG-UR/HG-AK Servo Motor Instruction Manual (Vol. 3)".
 - The external dynamic brake cannot be used for compliance with SEMI-F47 standard. Do not assign DB. Failure to do so will cause the drive unit to become servo-off when an instantaneous power failure occurs.
 - The control circuit power supply (L11/L21) can be connected by passing wiring. For details, refer to "MR-CV_/MR-CR55K_/MR-J4-DU_B_(-RJ)/MR-J4-DU_A_(-RJ) Instruction Manual".

Part 5: Review on Replacement of MR-J3-DU_ with MR-J4-DU_

(2) 400 V class

(a) MR-J3-DU_A4/MR-J4-DU_A4

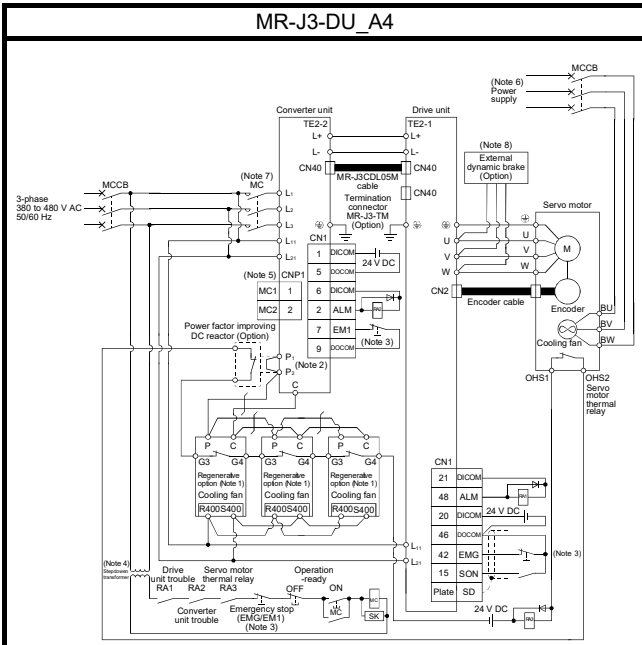

- Note 1. For the MR-RB138-4. For the MR-RB138-4, three units are used as one set (permissible wattage: 3900 W).
- When using the Power factor improving DC reactor, disconnect the short bar across P1 and P2.
 - Make up a sequence that will concurrently turn off the Emergency stop (EMG) of the drive unit and the Forced stop (EM1) of the converter unit, and shut off the main circuit power supply by the external sequence.
 - Stepdown transformer is required for coil voltage of magnetic contactor more than 200V class.
 - Keep the wiring connector for the magnetic contactor connected to CNP1 of the converter unit. Unconnected status may cause an electric shock.
 - For specifications of cooling fan power supply, refer to "MR-J3-_A_Servo Amplifier Instruction Manual".
 - Be sure to use a magnetic contactor with an operation delay time of 80 ms or less. The operation delay time is the time interval between current being applied to the coil until closure of contacts.
 - Use an external dynamic brake for the drive unit. Failure to do so will but cause an accident because the servo motor does not stop immediately coasts at an emergency stop and such conditions. Ensure the safety in the entire system.

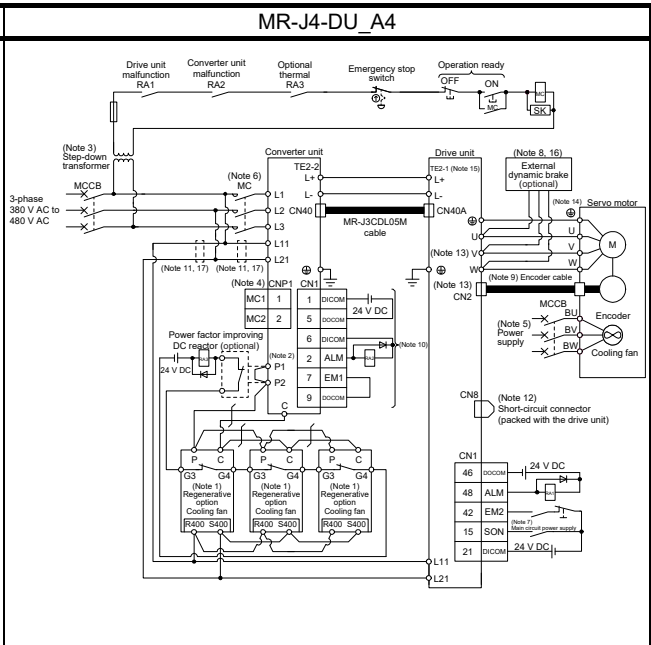

- Note 1. This is for MR-RB13V-4. For the MR-RB13V-4, three units are used as one set (permissible regenerative power: 3900 W).
- P1 and P2 are connected by default. When using the power factor improving DC reactor, connect P1 and P2 after removing the short bar across them. Refer to "Part: 10 section 7.3" for details.
 - A step-down transformer is required when the coil voltage of the magnetic contactor is 200 V class.
 - Always connect the magnetic contactor wiring connector to CNP1 of the converter unit. If the connector is not connected, an electric shock may occur.
 - For specifications of the cooling fan power supply, refer to "HG-MR/HG-KR/HG-SR/HG-JR/HG-RR/HG-UR/HG-AK Servo Motor Instruction Manual (Vol. 3)".
 - Use a magnetic contactor with an operation delay time (interval between current being applied to the coil until closure of contacts) of 80 ms or less. The bus voltage decreases depending on the main circuit voltage and operation pattern, which may cause the forced stop deceleration to shift to the dynamic brake deceleration. When dynamic brake deceleration is not required, slow the time to turn off the magnetic contactor.
 - To prevent an unexpected restart of the drive unit, configure a circuit to turn off EM2 in the drive unit when the main circuit power is turned off.
 - Use an external dynamic brake for the drive unit. Failure to do so will cause an accident because the servo motor does not stop immediately but coasts at an alarm occurrence for which the servo motor does not decelerate to stop. Ensure the safety in the entire equipment. For alarms for which the servo motor does not decelerate to stop, refer to chapter 6. For wiring of the external dynamic brake, refer to "MR-CV_/MR-CR55K_/MR-J4-DU_B_(-RJ)/MR-J4-DU_A_(-RJ) Instruction Manual".
 - For the encoder cable, use of the option cable is recommended. For selecting cables, refer to "HG-MR/HG-KR/HG-SR/HG-JR/HG-RR/HG-UR/HG-AK Servo Motor Instruction Manual (Vol. 3)".
 - This diagram shows sink I/O interface. For source I/O interface, refer to "MR-CV_/MR-CR55K_/MR-J4-DU_B_(-RJ)/MR-J4-DU_A_(-RJ) Instruction Manual".
 - Install an overcurrent protection device (molded-case circuit breaker or fuse) to protect the branch circuit. (Refer to section 7.3.)
 - When not using the STO function, attach the short-circuit connector supplied with the drive unit.
 - Do not connect the servo motor of a wrong axis to U, V, W, or CN2 of the drive unit. Otherwise, a malfunction may occur.
 - For connecting servo motor power wires, refer to "HG-MR/HG-KR/HG-SR/HG-JR/HG-RR/HG-UR/HG-AK Servo Motor Instruction Manual (Vol. 3)".
 - For the MR-J4-DU30K_4 and MR-J4-DU37K_4, the terminal block is TE2.
 - The external dynamic brake cannot be used for compliance with SEMI-F47 standard. Do not assign DB. Failure to do so will cause the drive unit to become servo-off when an instantaneous power failure occurs.
 - The control circuit power supply (L11/L21) can be connected by passing wiring. For details, refer to "MR-CV_/MR-CR55K_/MR-J4-DU_B_(-RJ)/MR-J4-DU_A_(-RJ) Instruction Manual".

Part 5: Review on Replacement of MR-J3-DU_ with MR-J4-DU_

(b) MR-J3-DU_B4/MR-J4-DU_B4

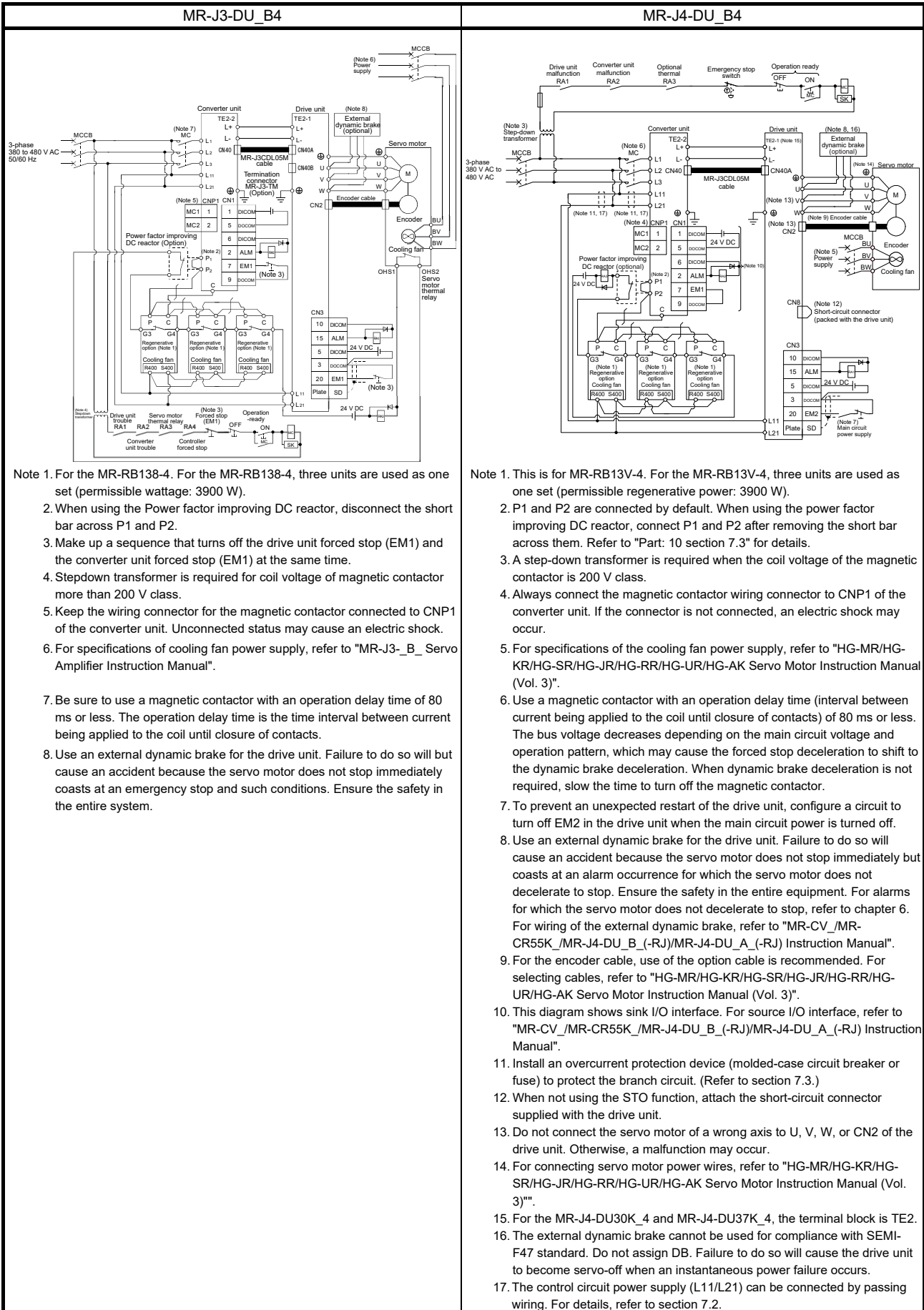

Part 5: Review on Replacement of MR-J3-DU_ with MR-J4-DU_

4.2 Power-on sequence

(1) MR-J3-DU_A

(a) Power-on procedure

- 1) Make sure to wire the power supply as shown in above section 4.1 using the magnetic contactor with the main circuit power supply (3-phase: L1, L2, L3). Configure up an external sequence to switch off the magnetic contactor as soon as an alarm occurs.

- 2) In the case where control function of the magnetic contactor for the converter unit is enabled, turn on control circuit power supply (L11 and L21) for the converter unit and the drive unit at the same time. After the converter unit and the drive unit are activated, main circuit power supply automatically turns on. When controlling the magnetic contactor by the external sequence, turn on the control circuit power supply (L11 and L21) for the converter unit and the drive unit concurrently with the main circuit power supply or before switching on the main circuit power supply. However, by switching on the main circuit power supply, the warning disappears and the drive unit will operate properly.

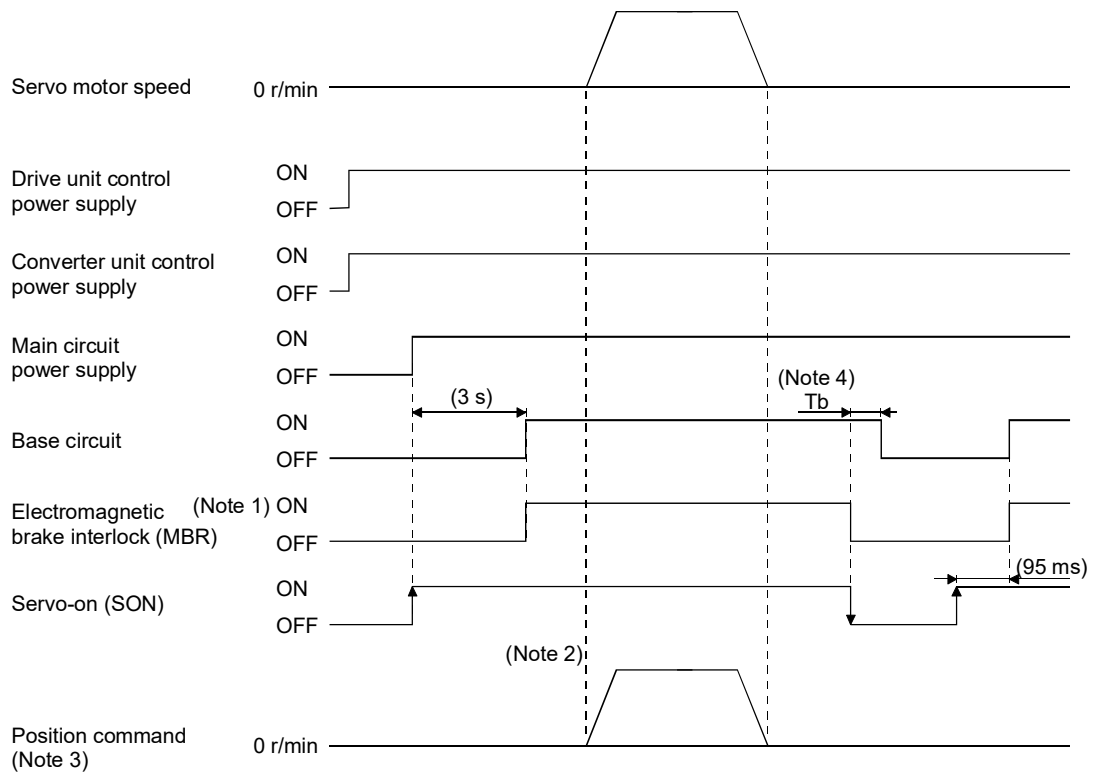

Note 1. When setting up an electromagnetic brake at customer's side, make up a sequence which will operate the electromagnetic brake as follow using the electromagnetic brake interlock (MBR).

ON: Electromagnetic brake is not activated.

OFF: Electromagnetic brake is activated

2. Give a position command after the external electromagnetic brake is released.

3. For the position control mode.

4. "Tb" is a delay time from when the electromagnetic brake interlock (MBR) is turned off until when the base circuit is shut off at servo off. Set Tb using [Pr. PC16].

Part 5: Review on Replacement of MR-J3-DU_ with MR-J4-DU_

(2) MR-J4-DU_A_

(a) Power-on procedure

- 1) Always use a magnetic contactor for the main circuit power supply wiring (L1/L2/L3) as shown in above section 4.1. Configure an external sequence to switch off the magnetic contactor as soon as an alarm occurs.

- 2) When enabling magnetic contactor drive output, turn on the control circuit power supplies (L11/L21) of the converter unit and the drive unit simultaneously. The main circuit power supply is automatically turned on after the converter unit and drive unit are started.
 When using an external sequence to control the magnetic contactor, turn on the control circuit power supplies (L11/L21) of the converter unit and drive unit simultaneously with the main circuit power supply or before turning on the main circuit power supply. If the main circuit power supply is not on, the display shows the corresponding warning. However, by switching on the main circuit power supply, the warning disappears and the drive unit will operate properly.

(b) Timing chart

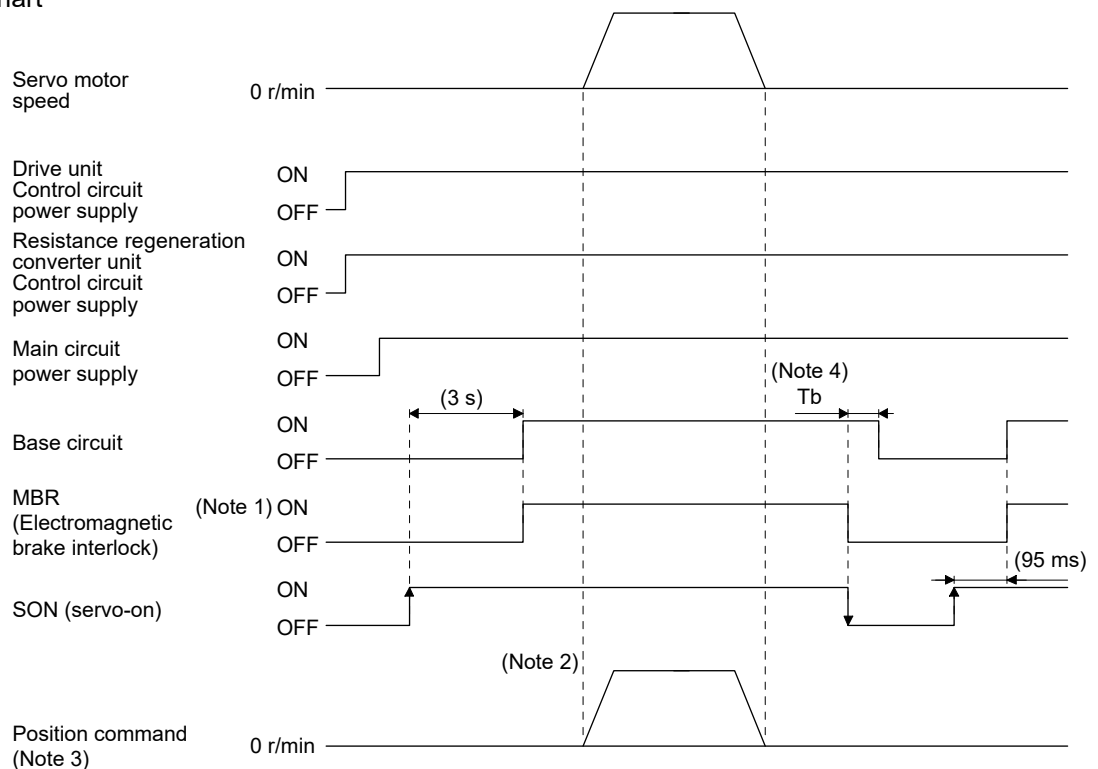

- Note 1. When setting up an electromagnetic brake at customer's side, make up a sequence which will operate the electromagnetic brake as follow using MBR.
 ON: Electromagnetic brake is not activated.
 OFF: Electromagnetic brake is activated.
- Note 2. Give a position command after the external electromagnetic brake is released.
- Note 3. This is in position control mode.
- Note 4. In [Pr. PC16 Electromagnetic brake sequence output], set a delay time (Tb) from MBR off to base circuit shut-off at a servo-off.

Part 5: Review on Replacement of MR-J3-DU_ with MR-J4-DU_

(3) MR-J3-DU_B

(a) Power-on procedure

- 1) Always wire the power supply as shown in above section 4.1 using the magnetic contactor with the main circuit power supply (3-phase: L1, L2, L3). Configure up an external sequence to switch off the magnetic contactor as soon as an alarm occurs.
- 2) Switch on the control circuit power supply L11, L21 simultaneously with the main circuit power supply or before switching on the main circuit power supply. If the main circuit power supply is not on, the display shows the corresponding warning. However, by switching on the main circuit power supply, the warning disappears and the drive unit will operate properly.

a) When control function of magnetic contactor is enabled and the status remains at ready on
The main circuit power is not shut off with servo off.

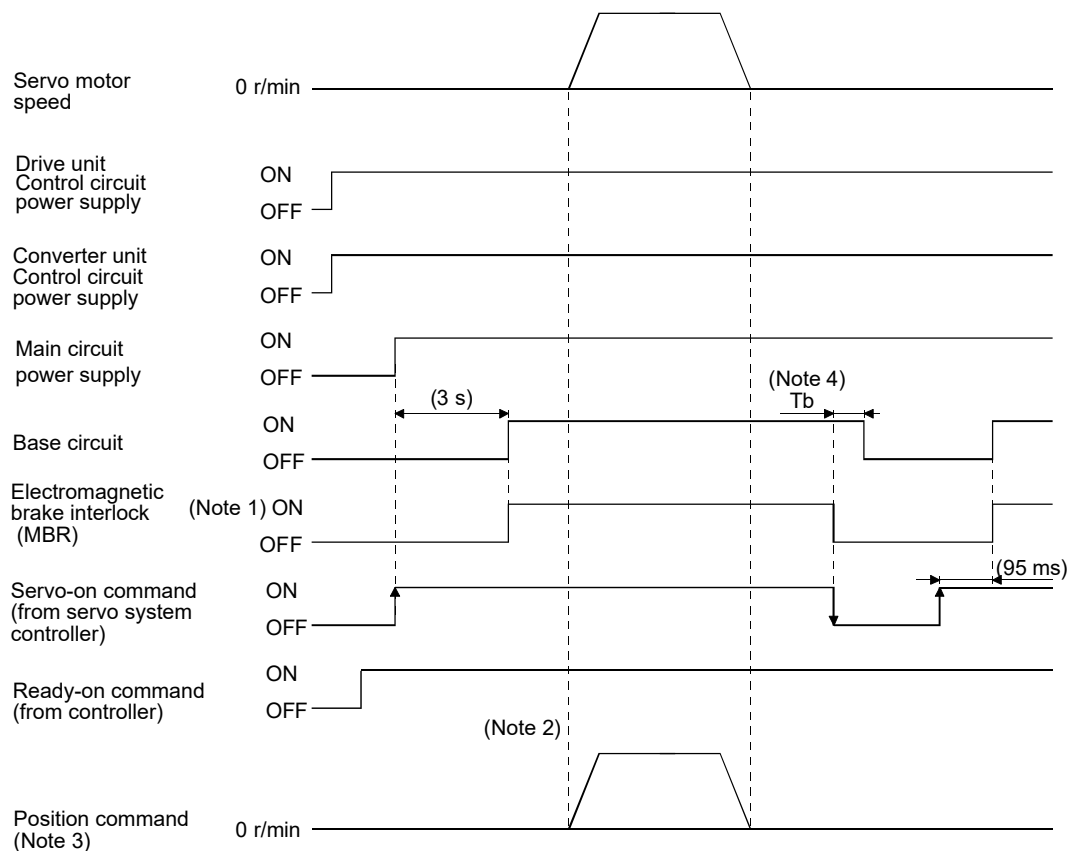

Note 1. When setting up an electromagnetic brake at customer's side, make up a sequence which will operate the electromagnetic brake as follow using the electromagnetic brake interlock (MBR).

ON: Electromagnetic brake is not activated.

OFF: Electromagnetic brake is activated

2. Give a position command after the external electromagnetic brake is released.

3. For the position control mode.

4. "Tb" is a delay time from when the electromagnetic brake interlock (MBR) is turned off until when the base circuit is shut off at servo off. Set Tb using [Pr. PC02].

Part 5: Review on Replacement of MR-J3-DU_ with MR-J4-DU_

- b) When control function of magnetic contactor is enabled and the status returns to ready-off
The magnetic contactor of the converter unit turns off with servo-off, and the main circuit power supply shuts off.

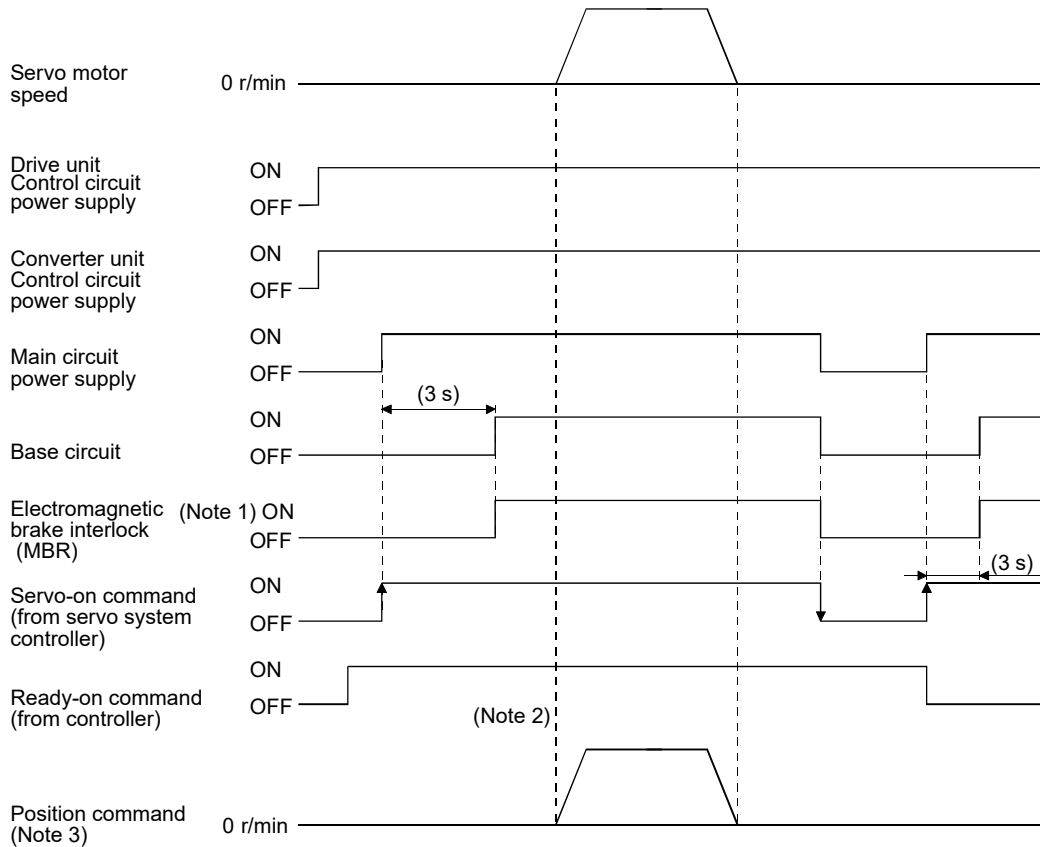

- Note 1. When setting up an electromagnetic brake at customer's side, make up a sequence which will operate the electromagnetic brake as follow using the electromagnetic brake interlock (MBR).
ON: Electromagnetic brake is not activated.
OFF: Electromagnetic brake is activated
- Note 2. Give a position command after the external electromagnetic brake is released.
- Note 3. For the position control mode.

Part 5: Review on Replacement of MR-J3-DU_ with MR-J4-DU_

c) When using an external sequence to control the magnetic contactor

When an alarm occurs, turn off the magnetic contactor using the external sequence, and shut off the main circuit power supply.

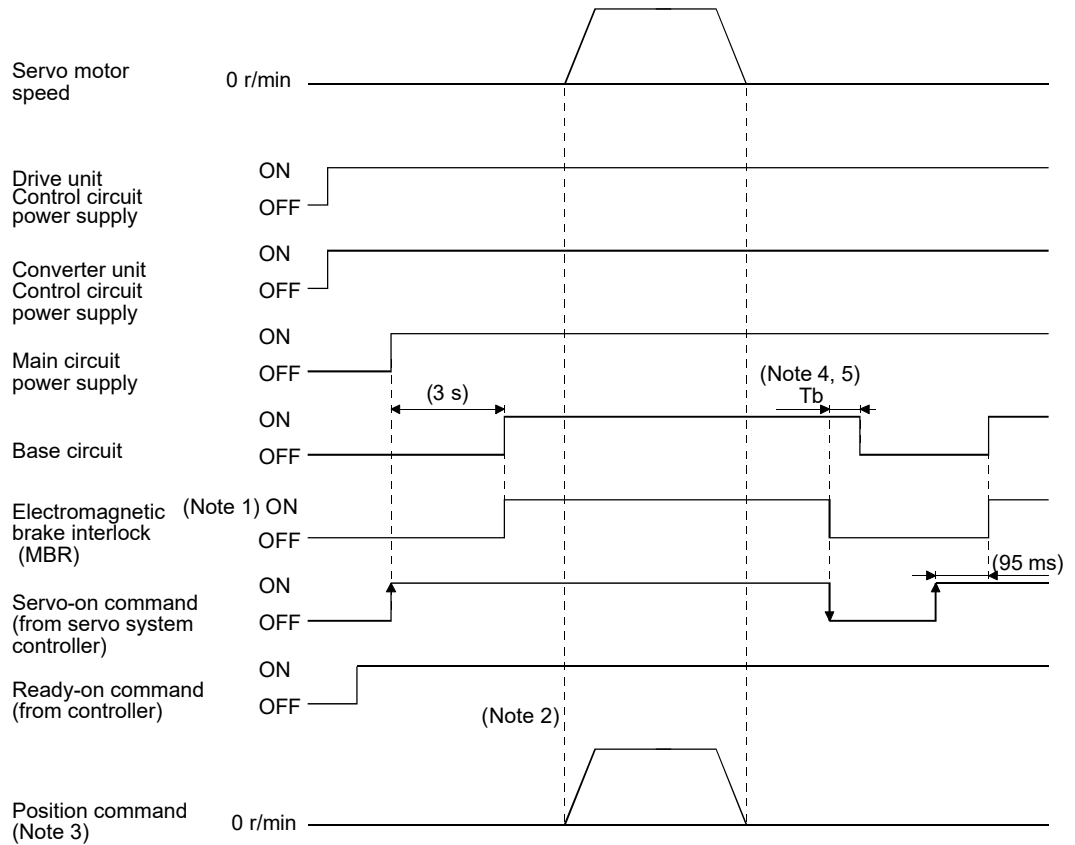

- Note 1. When setting up an electromagnetic brake at customer's side, make up a sequence which will operate the electromagnetic brake as follow using the electromagnetic brake interlock (MBR).
 ON: Electromagnetic brake is not activated.
 OFF: Electromagnetic brake is activated
- Note 2. Give a position command after the external electromagnetic brake is released.
- Note 3. For the position control mode.
- Note 4. "Tb" is a delay time from when the electromagnetic brake interlock (MBR) is turned off until when the base circuit is shut off at servo off. Set Tb using [Pr. PC02].
- Note 5. The base circuit remains ready-on status at servo-off. When the status is ready-off, the base circuit and the servo-on command turn off at the same time. (Tb = 0)

Part 5: Review on Replacement of MR-J3-DU_ with MR-J4-DU_

(4) MR-J4-DU_B_

(a) Power-on procedure

- 1) Always use a magnetic contactor for the main circuit power supply wiring (L1/L2/L3) as shown in above section 4.1. Configure an external sequence to switch off the magnetic contactor as soon as an alarm occurs.
- 2) Turn on the control circuit power supplies (L11/L21) of the converter unit and drive unit simultaneously with the main circuit power supply or before turning on the main circuit power supply. If the main circuit power supply is not on, the display shows the corresponding warning. However, by switching on the main circuit power supply, the warning disappears and the drive unit will operate properly.

(b) Timing chart

- 1) When magnetic contactor drive output is enabled and the status remains at ready-on The main circuit power is not shut off with servo-off.

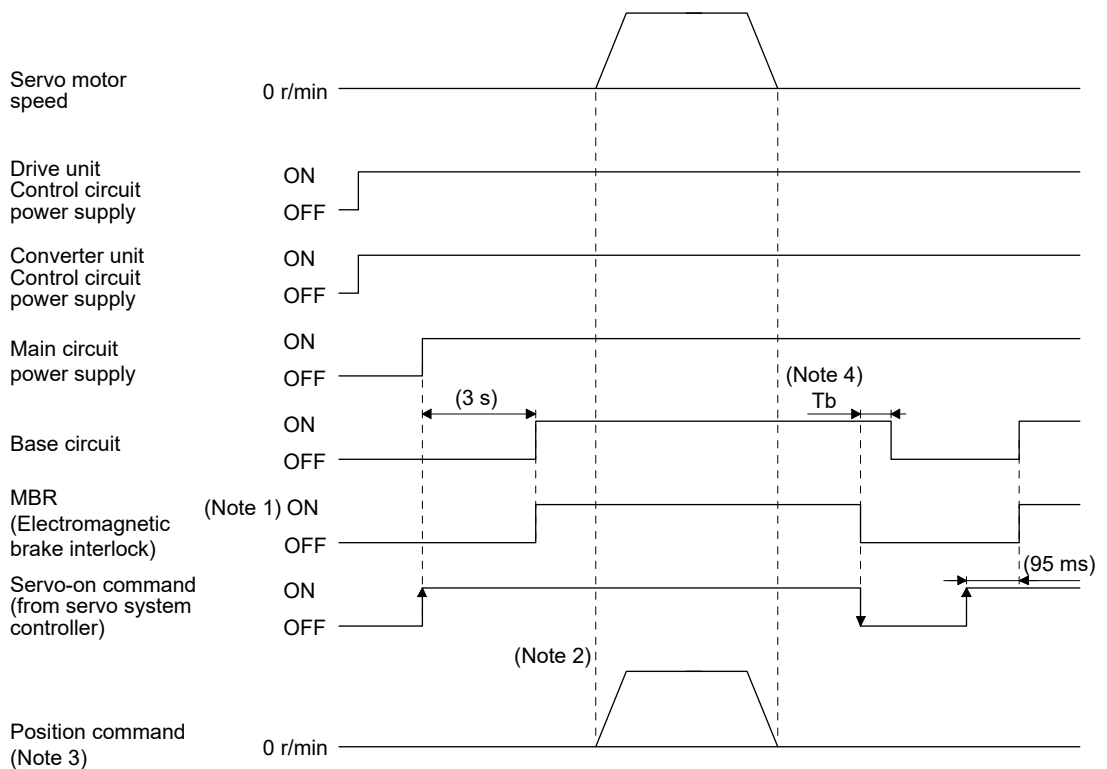

- Note 1. When setting up an electromagnetic brake at customer's side, make up a sequence which will operate the electromagnetic brake as follow using MBR.
 ON: Electromagnetic brake is not activated.
 OFF: Electromagnetic brake is activated.
2. Give a position command after the external electromagnetic brake is released.
 3. This is in position control mode.
 4. In [Pr. PC02 Electromagnetic brake sequence output], set a delay time (T_b) from MBR off to base circuit shut-off at a servo-off.

Part 5: Review on Replacement of MR-J3-DU_ with MR-J4-DU_

- 2) When magnetic contactor drive output is enabled and the status returns to ready-off
 The magnetic contactor of the resistance regeneration converter unit is turned off with ready-off, and the main circuit power supply is shut off.

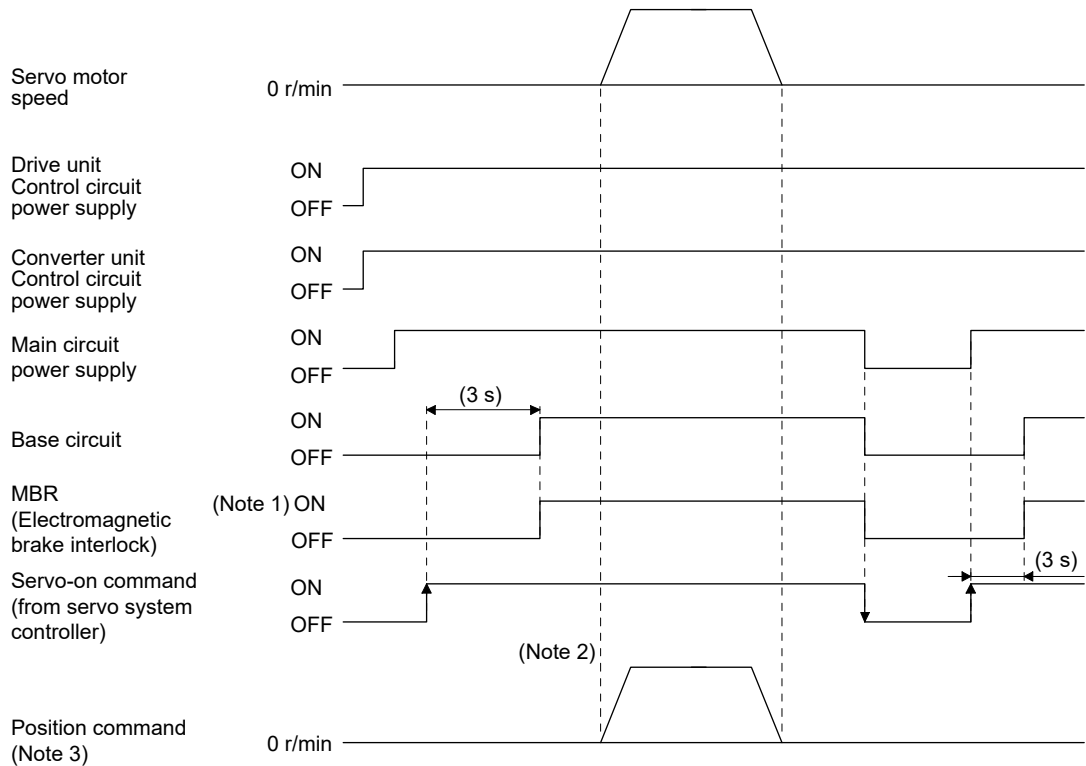

- Note 1. When setting up an electromagnetic brake at customer's side, make up a sequence which will operate the electromagnetic brake as follow using MBR.
 ON: Electromagnetic brake is not activated.
 OFF: Electromagnetic brake is activated.
2. Give a position command after the external electromagnetic brake is released.
3. This is in position control mode.

Part 5: Review on Replacement of MR-J3-DU_ with MR-J4-DU_

3) When magnetic contactor drive output is disabled

When an alarm occurs, turn off the magnetic contactor using the external sequence, and shut off the main circuit power supply.

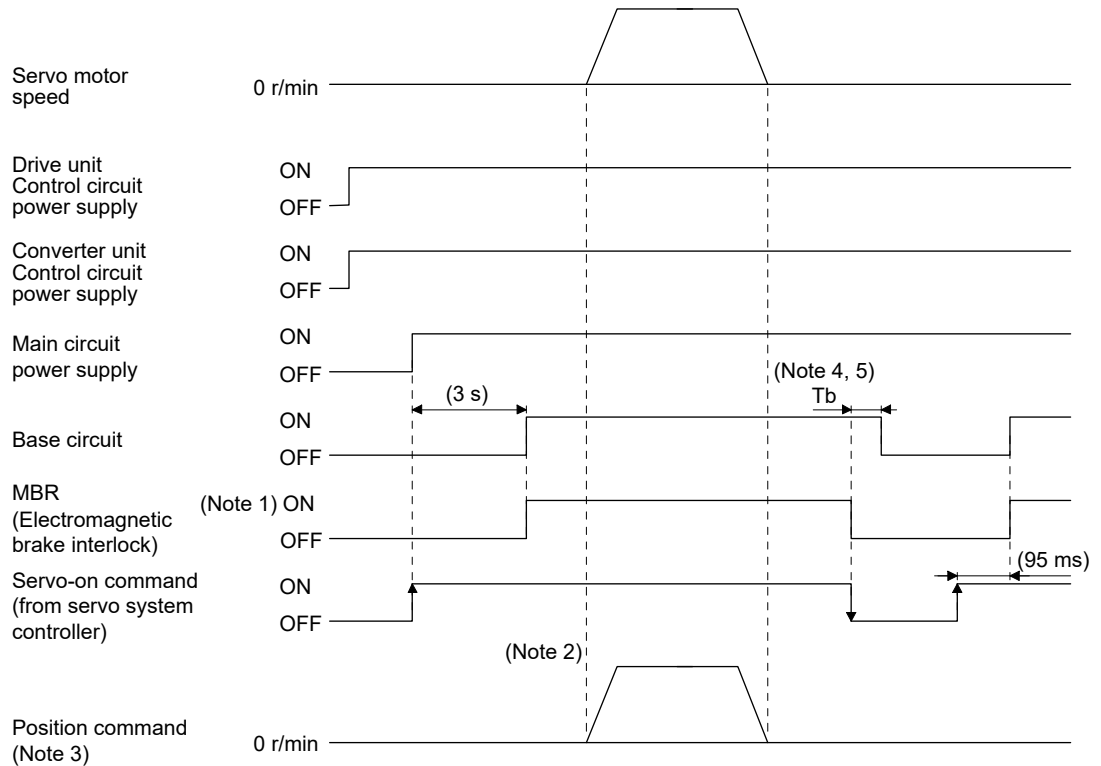

- Note 1. When setting up an electromagnetic brake at customer's side, make up a sequence which will operate the electromagnetic brake as follow using MBR.
 ON: Electromagnetic brake is not activated.
 OFF: Electromagnetic brake is activated.
2. Give a position command after the external electromagnetic brake is released.
3. This is in position control mode.
4. In [Pr. PC02 Electromagnetic brake sequence output], set a delay time (T_b) from MBR off to base circuit shut-off at a servo-off.
5. The base circuit remains ready-on status at servo-off. When the status is ready-off, the base circuit and the servo-on command turn off at the same time. ($T_b = 0$)

Part 5: Review on Replacement of MR-J3-DU_ with MR-J4-DU_

4.3 List of corresponding connectors and terminal blocks

(1) Converter unit

(a) Connector comparison table

For details on signals, refer to each servo amplifier instruction manual.

MR-J3-CR55K/MR-J3-CR55K4	MR-CR55K/MR-CR55K4																																								
<p>③CNP1, ②CN1, ①CN40 Connect to CN40A of the drive unit. CN6 Do not connect anything including. CN3 Do not connect anything including. ⑤TE2-1, ⑤TE2-2, ④TE3, ⑦TE1-1, ⑥TE1-2, PE</p>	<p>③CNP1, ②CN1, ①CN40 Connect to CN40A of the drive unit. CN6 Do not connect anything including. CN3 Do not connect anything including. ⑤TE2-1, ⑤TE2-2, ④TE3, ⑦TE1-1, ⑥TE1-2, PE</p>																																								
<p>CN1</p> <table border="1"> <thead> <tr> <th>Connector pin No.</th> <th>Signal abbreviation</th> </tr> </thead> <tbody> <tr><td>CN1-1</td><td>DICOM</td></tr> <tr><td>CN1-2</td><td>ALM</td></tr> <tr><td>CN1-3</td><td></td></tr> <tr><td>CN1-4</td><td></td></tr> <tr><td>CN1-5</td><td>DOCOM</td></tr> <tr><td>CN1-6</td><td>DICOM</td></tr> <tr><td>CN1-7</td><td>EM1</td></tr> <tr><td>CN1-8</td><td>WNG</td></tr> <tr><td>CN1-9</td><td>DOCOM</td></tr> </tbody> </table>	Connector pin No.	Signal abbreviation	CN1-1	DICOM	CN1-2	ALM	CN1-3		CN1-4		CN1-5	DOCOM	CN1-6	DICOM	CN1-7	EM1	CN1-8	WNG	CN1-9	DOCOM	<p>CN1</p> <table border="1"> <thead> <tr> <th>Connector pin No.</th> <th>Signal abbreviation</th> </tr> </thead> <tbody> <tr><td>CN1-1</td><td>DICOM</td></tr> <tr><td>CN1-2</td><td>ALM</td></tr> <tr><td>CN1-3</td><td></td></tr> <tr><td>CN1-4</td><td></td></tr> <tr><td>CN1-5</td><td>DOCOM</td></tr> <tr><td>CN1-6</td><td>DICOM</td></tr> <tr><td>CN1-7</td><td>EM1</td></tr> <tr><td>CN1-8</td><td>WNG</td></tr> <tr><td>CN1-9</td><td>DOCOM</td></tr> </tbody> </table>	Connector pin No.	Signal abbreviation	CN1-1	DICOM	CN1-2	ALM	CN1-3		CN1-4		CN1-5	DOCOM	CN1-6	DICOM	CN1-7	EM1	CN1-8	WNG	CN1-9	DOCOM
Connector pin No.	Signal abbreviation																																								
CN1-1	DICOM																																								
CN1-2	ALM																																								
CN1-3																																									
CN1-4																																									
CN1-5	DOCOM																																								
CN1-6	DICOM																																								
CN1-7	EM1																																								
CN1-8	WNG																																								
CN1-9	DOCOM																																								
Connector pin No.	Signal abbreviation																																								
CN1-1	DICOM																																								
CN1-2	ALM																																								
CN1-3																																									
CN1-4																																									
CN1-5	DOCOM																																								
CN1-6	DICOM																																								
CN1-7	EM1																																								
CN1-8	WNG																																								
CN1-9	DOCOM																																								
<p>CNP1</p> <table border="1"> <thead> <tr> <th>Connector pin No.</th> <th>Signal abbreviation</th> </tr> </thead> <tbody> <tr><td>CNP1-1</td><td>MC1</td></tr> <tr><td>CNP1-2</td><td>MC2</td></tr> </tbody> </table>	Connector pin No.	Signal abbreviation	CNP1-1	MC1	CNP1-2	MC2	<p>CNP1</p> <table border="1"> <thead> <tr> <th>Connector pin No.</th> <th>Signal abbreviation</th> </tr> </thead> <tbody> <tr><td>CNP1-1</td><td>MC1</td></tr> <tr><td>CNP1-2</td><td>MC2</td></tr> </tbody> </table>	Connector pin No.	Signal abbreviation	CNP1-1	MC1	CNP1-2	MC2																												
Connector pin No.	Signal abbreviation																																								
CNP1-1	MC1																																								
CNP1-2	MC2																																								
Connector pin No.	Signal abbreviation																																								
CNP1-1	MC1																																								
CNP1-2	MC2																																								

(b) List of corresponding connectors and terminal blocks

No.	Connector name	Connector No.
①	Protection coordination connector	CN40
②	I/O signal connector	CN1
③	Magnetic contactor control connector	CNP1
④	Control circuit terminal block	TE3
⑤	L+/L- terminal	TE2-1
		TE2-2
⑥	Regenerative option/Power factor improving DC reactor	TE1-2
⑦	Main circuit terminal block	TE1-1

→

No.	Connector name	Connector No.
①	Protection coordination connector	CN40
②	I/O signal connector	CN1
③	Magnetic contactor control connector	CNP1
④	Control circuit terminal	TE3
⑤	L+/L- terminal	TE2-1
		TE2-2
⑥	Regenerative option/Power factor improving DC reactor	TE1-2
⑦	Main circuit terminal block	TE1-1

Part 5: Review on Replacement of MR-J3-DU_ with MR-J4-DU_

(2) Drive unit (General-Purpose interface)

(a) Connector comparison table

For details on signals, refer to each servo amplifier instruction manual.

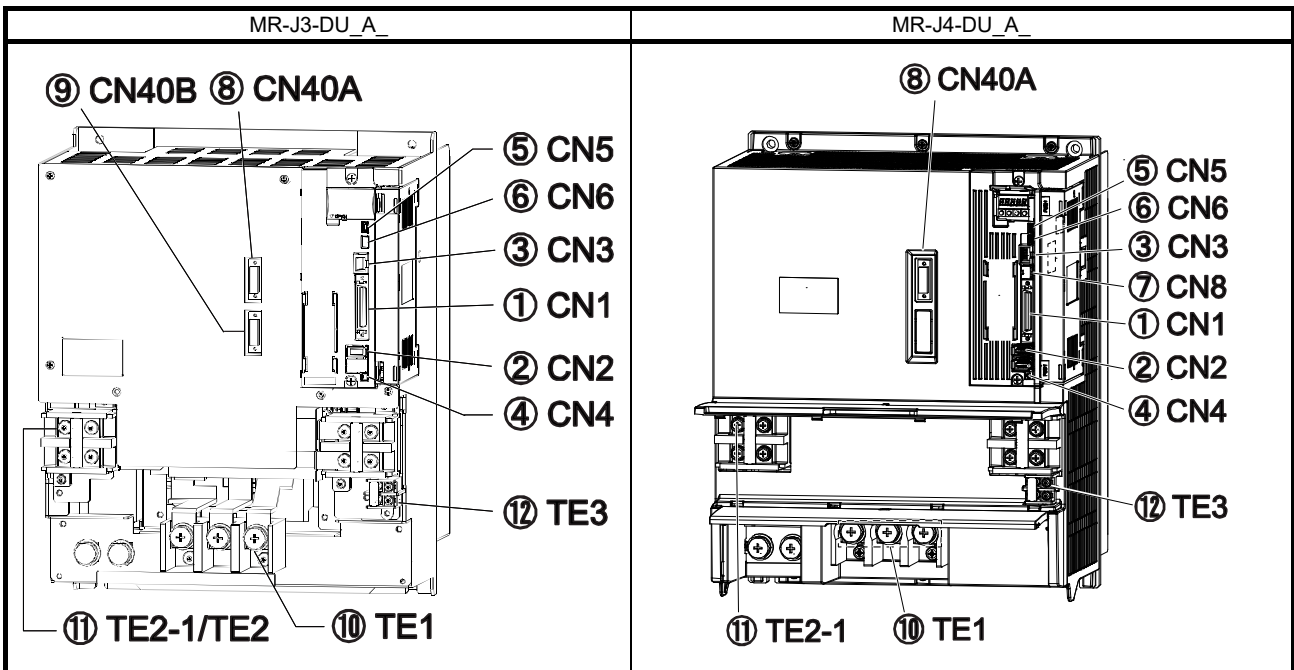

(b) List of corresponding connectors and terminal blocks

MR-J3-DU_A			MR-J4-DU_A			Precautions
No.	Connector name	Connector No.	No.	Connector name	Connector No.	
①	I/O signal connector	CN1	①	I/O signal connector	CN1	
②	Encoder connector	CN2	②	Encoder connector	CN2	When connected to an HG-JR motor, the encoder cable needs to be changed.
③	RS-422 communication connector	CN3	③	RS-422 communication connector	CN3	
④	Battery connector	CN4	④	Battery connector	CN4	Use the dedicated battery of each series.
⑤	USB communication connector	CN5	⑤	USB communication connector	CN5	
⑥	Analog monitor connector	CN6	⑥	Analog monitor connector	CN6	
⑦			⑦	STO input signal connector	CN8	When not using the STO function, attach the short-circuit connector supplied with the drive unit to CN8 (STO I/O signal connector).
⑧	Converter unit connectors	CN40A	⑧	Protection coordination connector	CN40A	
⑨	Converter unit connectors	CN40B	⑨			
⑩	Servo motor power supply terminals	TE1	⑩	Servo motor power output terminal	TE1	The structure of the main circuit terminal block varies depending on the capacity. Refer to "Part 8 Common Reference Material".
⑪	L+/L- terminals	TE2-1/TE2	⑪	L+/L- terminal	TE2-1	
⑫	Control circuit terminal L11/L21	TE3	⑫	Control circuit terminal L11/L21	TE3	

Part 5: Review on Replacement of MR-J3-DU_ with MR-J4-DU_

(c) Comparison of signals

Signal abbreviations in parentheses are for MR-J4-DU_A_.

1) CN1

This is the signal symbol in the positioning mode. For other signal names, refer to "MR-CV_/MR-CR55K_/MR-J4-DU_B_(-RJ)/MR-J4-DU_A_(-RJ) Instruction Manual".

MR-J3- A_				Signal abbreviation	MR-J4- A_					
Connector pin assignment				Connector pin No.	Connector pin No.	Connector pin assignment				
				CN1-1	P15R	CN1-1				
				CN1-2		CN1-2				
				CN1-3	LG	CN1-3				
				CN1-4	LA	CN1-4				
				CN1-5	LAR	CN1-5				
				CN1-6	LB	CN1-6				
				CN1-7	LBR	CN1-7				
				CN1-8	LZ	CN1-8				
				CN1-9	LZR	CN1-9				
				CN1-10	PP	CN1-10				
				CN1-11	PG	CN1-11				
				CN1-12	OPC	CN1-12				
				CN1-13		CN1-13				
				CN1-14		CN1-14				
				CN1-15	SON	CN1-15				
				CN1-16		CN1-16				
				CN1-17	PC	CN1-17				
				CN1-18	TL	CN1-18				
				CN1-19	RES	CN1-19				
				CN1-20	DICOM	CN1-20				
				CN1-21	DICOM	CN1-21				
				CN1-22	INP	CN1-22				
				CN1-23	ZSP	CN1-23				
				CN1-24	INP	CN1-24				
				CN1-25	TLC	CN1-25				
				CN1-26		CN1-26				
				CN1-27	TLA	CN1-27				
				CN1-28	LG	CN1-28				
				CN1-29		CN1-29				
				CN1-30	LG	CN1-30				
				CN1-31		CN1-31				
				CN1-32		CN1-32				
				CN1-33	OP	CN1-33				
				CN1-34	LG	CN1-34				
				CN1-35	NP	CN1-35				
				CN1-36	NG	CN1-36				
				CN1-37	(PP2)	CN1-37				
				CN1-38	(NP2)	CN1-38				
				CN1-39		CN1-39				
				CN1-40		CN1-40				
				CN1-41	CR	CN1-41				
				CN1-42	EMG (EM2)	CN1-42				
				CN1-43	LSP	CN1-43				
				CN1-44	LSN	CN1-44				
				CN1-45	LOP	CN1-45				
				CN1-46	DOCOM	CN1-46				
				CN1-47	DOCOM	CN1-47				
				CN1-48	ALM	CN1-48				
				CN1-49	RD	CN1-49				
				CN1-50		CN1-50				

MR-J3- A_			
Connector pin assignment			
2	1	27	26
	P15R		
	3	TLA	28
4	LG	29	LG
LA	5		30
6	LAR	31	LG
LB	7		32
8	LBR	33	
LZ	9	OP	34
10	LZR	35	LG
PP	11	NP	36
12	PG	37	NG
OPC	13		38
14		39	
	15		40
16	SON	41	
	17	CR	42
18	PC	43	EMG
TL	19	LSP	44
20	RES	45	LSN
DICOM	21	LOP	46
22	DICOM	47	DOCOM
INP	23	DOCOM	48
24	ZSP	49	ALM
INP	25	RD	50
	TLC		

MR-J4- A_			
Connector pin assignment			
2	1	27	26
	P15R		
	3	TLA	28
4	LG	29	LG
LA	5		30
6	LAR	31	LG
LB	7		32
8	LBR	33	
LZ	9	OP	34
10	LZR	35	LG
PP	11	NP	36
12	PG	37	NG
OPC	13	PP2	38
14		39	NP2
	15		40
16	SON	41	
	17	CR	42
18	PC	43	EM2
TL	19	LSP	44
20	RES	45	LSN
DICOM	21	LOP	46
22	DICOM	47	DOCOM
INP	23	DOCOM	48
24	ZSP	49	ALM
INP	25	RD	50
	TLC		

Part 5: Review on Replacement of MR-J3-DU_ with MR-J4-DU_

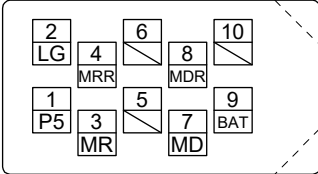
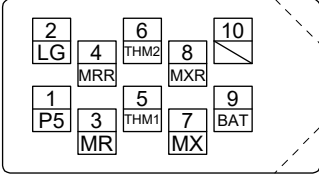

2) CN2

MR-J3-DU_A_		Signal abbreviation	MR-J4-DU_A_	
Connector pin assignment	Connector pin No.		Connector pin No.	Connector pin assignment
	CN2-1	P5	CN2-1	
	CN2-2	LG	CN2-2	
	CN2-3	MR	CN2-3	
	CN2-4	MRR	CN2-4	
	CN2-5	(THM1)	CN2-5	
	CN2-6	(THM2)	CN2-6	
	CN2-7	MD (MX)	CN2-7	
	CN2-8	MDR (MXR)	CN2-8	
	CN2-9	BAT	CN2-9	
	CN2-10		CN2-10	

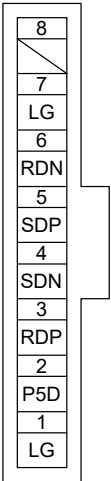
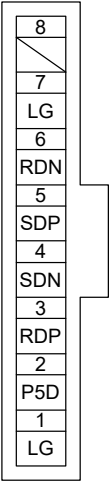
3) CN3

MR-J3-DU_A_		Signal abbreviation	MR-J4-DU_A_	
Connector pin assignment	Connector pin No.		Connector pin No.	Connector pin assignment
	CN3-1	LG	CN3-1	
	CN3-2	P5D	CN3-2	
	CN3-3	RDP	CN3-3	
	CN3-4	SDN	CN3-4	
	CN3-5	SDP	CN3-5	
	CN3-6	RDN	CN3-6	
	CN3-7	LG	CN3-7	
	CN3-8	TRE	CN3-8	

4) CN6

MR-J3-DU_A_		Signal abbreviation	MR-J4-DU_A_	
Connector pin assignment	Connector pin No.		Connector pin No.	Connector pin assignment
	CN6-3	MO1	CN6-3	
	CN6-2	MO2	CN6-2	
	CN6-1	LG	CN6-1	

Part 5: Review on Replacement of MR-J3-DU_ with MR-J4-DU_

5) CN8

When not using the STO function, attach the short-circuit connector supplied with the drive unit to CN8 (STO I/O signal connector).

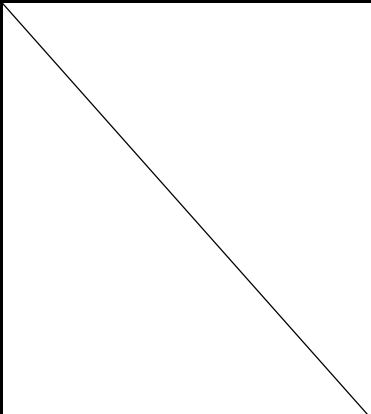
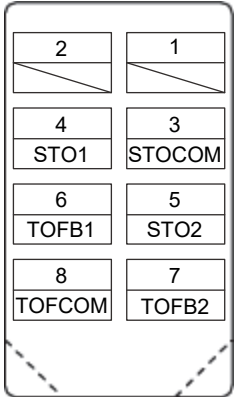
MR-J3-DU_A_		Signal abbreviation	MR-J4-DU_A_		
Connector pin assignment	Connector pin No.		Connector pin No.	Connector pin assignment	
			CN8-1		
			CN8-2		
			STOCOM		CN8-3
			STO1		CN8-4
			STO2		CN8-5
			TOFB1		CN8-6
			TOFB2		CN8-7
			TOFCOM		CN8-8

6) CN40A

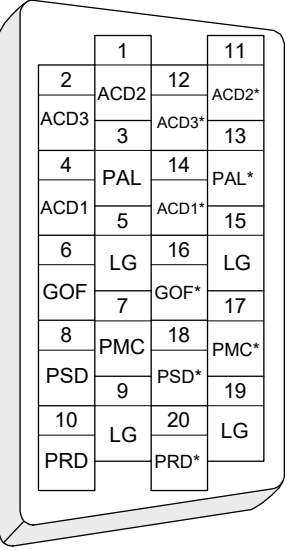
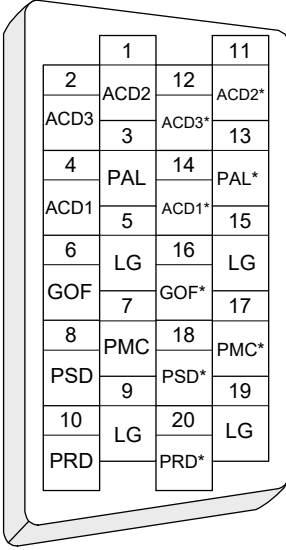
MR-J3-DU_A_		Signal abbreviation	MR-J4-DU_A_	
Connector pin assignment	Connector pin No.		Connector pin No.	Connector pin assignment
	CN40A-1	ACD2	CN40A-1	
	CN40A-2	ACD3	CN40A-2	
	CN40A-3	PAL	CN40A-3	
	CN40A-4	ACD1	CN40A-4	
	CN40A-5	LG	CN40A-5	
	CN40A-6	GOF	CN40A-6	
	CN40A-7	PMC	CN40A-7	
	CN40A-8	PSD	CN40A-8	
	CN40A-9	LG	CN40A-9	
	CN40A-10	PRD	CN40A-10	
	CN40A-11	ACD2*	CN40A-11	
	CN40A-12	ACD3*	CN40A-12	
	CN40A-13	PAL*	CN40A-13	
	CN40A-14	ACD1*	CN40A-14	
	CN40A-15	LG	CN40A-15	
	CN40A-16	GOF*	CN40A-16	
	CN40A-17	PMC*	CN40A-17	
	CN40A-18	PSD*	CN40A-18	
	CN40A-19	LG	CN40A-19	
	CN40A-20	PRD*	CN40A-20	

7) CN40B

When MR-J4-DU_A is used, the terminal connector (MR-J3-TM) does not need to be connected to CN40B. (This product does not have a connector for the terminal connector.)

Part 5: Review on Replacement of MR-J3-DU_ with MR-J4-DU_

- (3) Drive unit (SSCNET interface)
 - (a) Connector comparison table

For details on signals, refer to each servo amplifier instruction manual.

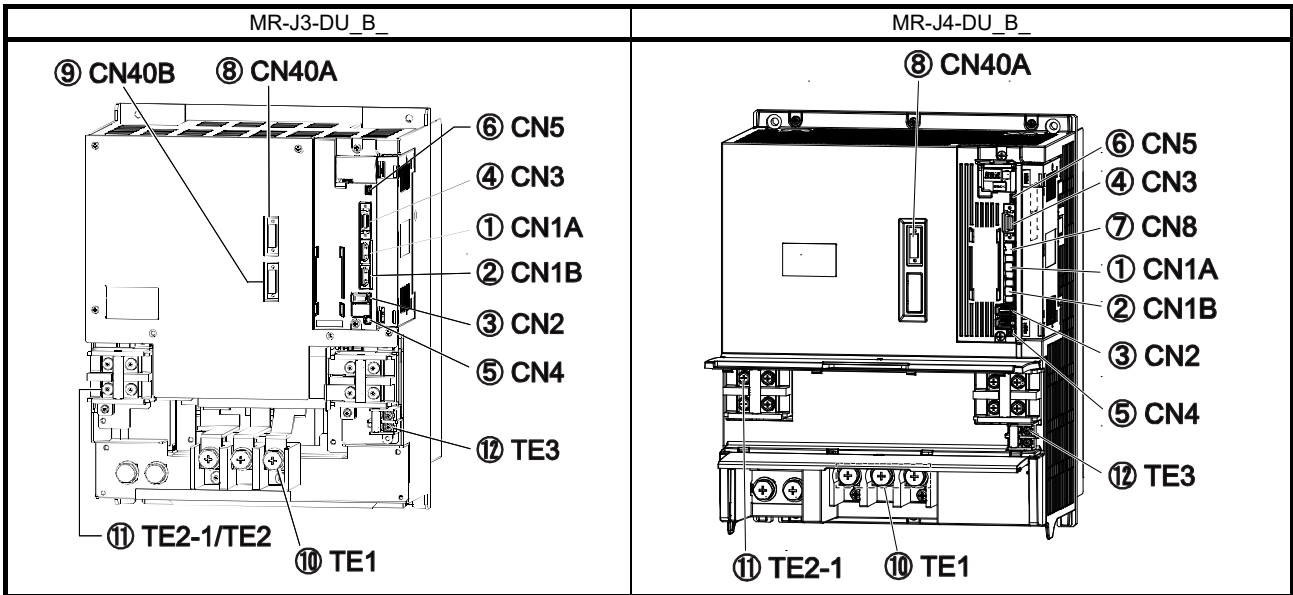

(b) List of connector and terminal block correspondence

MR-J3-DU_B			MR-J4-DU_B			Precautions
No.	Connector name	Connector No.	No.	Connector name	Connector No.	
①	SSCNET III cable connector	CN1A	①	SSCNET III cable connector	CN1A	
②	SSCNET III cable connector	CN1B	②	SSCNET III cable connector	CN1B	
③	Encoder connector	CN2	③	Encoder connector	CN2	When connected to an HG-JR motor, the encoder cable needs to be changed.
④	I/O signal connector	CN3	④	I/O signal connector	CN3	
⑤	Battery connector	CN4	⑤	Battery connector	CN4	
⑥	USB communication connector	CN5	⑥	USB communication connector	CN5	
⑦			⑦	STO input signal connector	CN8	
⑧	Converter unit connectors	CN40A	⑧	Protection coordination connector	CN40A	
⑨	Converter unit connectors	CN40B	⑨			
⑩	Servo motor power supply terminals	TE1	⑩	Servo motor power output terminal	TE1	The structure of the main circuit terminal block varies depending on the capacity. Refer to "Part 8 Common Reference Material"
⑪	L+/L- terminals	TE2-1/TE2	⑪	L+/L- terminal	TE2-1	
⑫	Control circuit terminal L11/L21	TE3	⑫	Control circuit terminal L11/L21	TE3	

Part 5: Review on Replacement of MR-J3-DU_ with MR-J4-DU_

(c) Comparison of signals

Signal abbreviations in parentheses are for MR-J4-DU_B_.

1) CN2

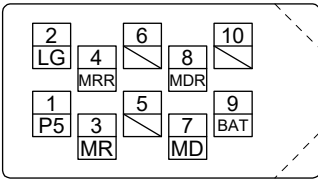
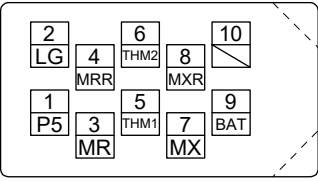
MR-J3-DU_B_		Signal abbreviation	MR-J4-DU_B_	
Connector pin assignment	Connector pin No.		Connector pin No.	Connector pin assignment
	CN2-1	P5	CN2-1	
	CN2-2	LG	CN2-2	
	CN2-3	MR	CN2-3	
	CN2-4	MRR	CN2-4	
	CN2-5	(THM1)	CN2-5	
	CN2-6	(THM2)	CN2-6	
	CN2-7	MD	CN2-7	
		(MX)		
	CN2-8	MDR	CN2-8	
		(MXR)		
CN2-9	BAT	CN2-9		
CN2-10		CN2-10		

2) CN3

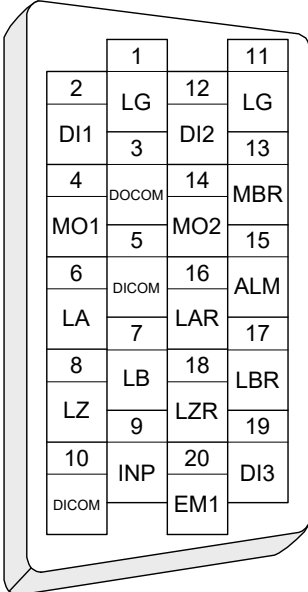
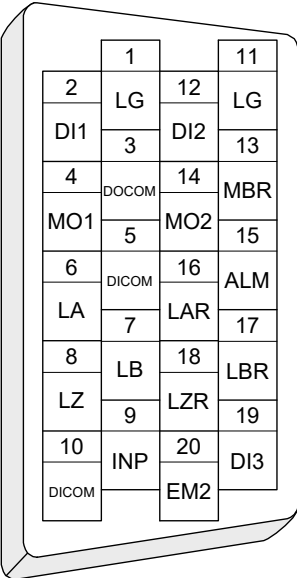
MR-J3-DU_B_		Signal abbreviation	MR-J4-DU_B_	
Connector pin assignment	Connector pin No.		Connector pin No.	Connector pin assignment
	CN3-1	LG	CN3-1	
	CN3-2	DI1	CN3-2	
	CN3-3	DOCOM	CN3-3	
	CN3-4	MO1	CN3-4	
	CN3-5	DICOM	CN3-5	
	CN3-6	LA	CN3-6	
	CN3-7	LB	CN3-7	
	CN3-8	LZ	CN3-8	
	CN3-9	INP	CN3-9 (Note 1)	
	CN3-10	DICOM	CN3-10	
	CN3-11	LG	CN3-11	
	CN3-12	DI2	CN3-12	
	CN3-13	MBR	CN3-13 (Note 1)	
	CN3-14	MO2	CN3-14	
	CN3-15	ALM	CN3-15 (Note 1)	
	CN3-16	LAR	CN3-16	
	CN3-17	LBR	CN3-17	
	CN3-18	LZR	CN3-18	
	CN3-19	DI3	CN3-19	
	CN3-20	EM1 (EM2)	CN3-20 (Note 2)	

- Note 1. Set with [Pr. PD07] to [PD09] for use.
 2. The factory setting for MR-J4-_B_ is EM2.

Part 5: Review on Replacement of MR-J3-DU_ with MR-J4-DU_

3) CN8

When not using the STO function, attach the short-circuit connector supplied with the drive unit to CN8 (STO I/O signal connector).

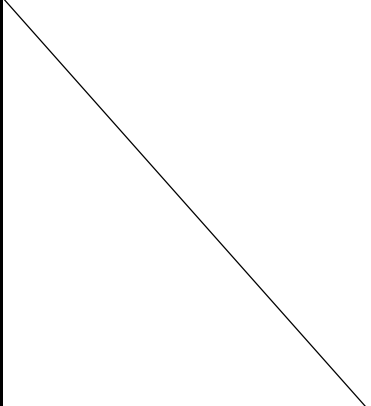
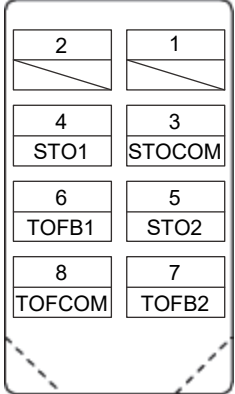
MR-J3-DU_B_		Signal abbreviation	MR-J4-DU_B_		
Connector pin assignment	Connector pin No.		Connector pin No.	Connector pin assignment	
			CN8-1		
			CN8-2		
			STOCOM		CN8-3
			STO1		CN8-4
			STO2		CN8-5
			TOFB1		CN8-6
			TOFB2		CN8-7
			TOFCOM		CN8-8

4) CN40A

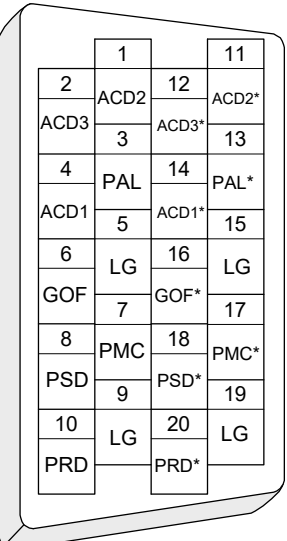
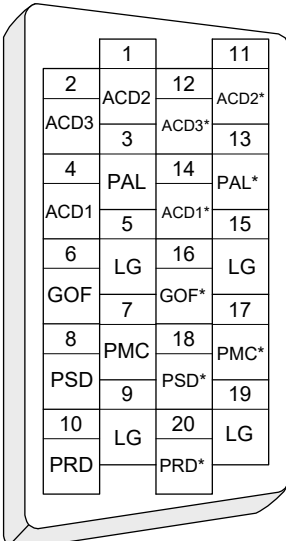
MR-J3-DU_B_		Signal abbreviation	MR-J4-DU_B_		
Connector pin assignment	Connector pin No.		Connector pin No.	Connector pin assignment	
		ACD2	CN40A-1		
			ACD3		CN40A-2
			PAL		CN40A-3
			ACD1		CN40A-4
			LG		CN40A-5
			GOF		CN40A-6
			PMC		CN40A-7
			PSD		CN40A-8
			LG		CN40A-9
			PRD		CN40A-10
			ACD2*		CN40A-11
			ACD3*		CN40A-12
			PAL*		CN40A-13
			ACD1*		CN40A-14
			LG		CN40A-15
			GOF*		CN40A-16
			PMC*		CN40A-17
			PSD*		CN40A-18
			LG		CN40A-19
			PRD*		CN40A-20

5) CN40B

When MR-J4-DU_B is used, the terminal connector (MR-J3-TM) does not need to be connected to CN40B. (This product does not have a connector for the terminal connector.)

Part 5: Review on Replacement of MR-J3-DU_ with MR-J4-DU_

5. PARAMETER

CAUTION

- Never make a drastic adjustment or change to the parameter values as doing so will make the operation unstable.
- Do not change the parameter settings as described below. Doing so may cause an unexpected condition, such as failing to start up the drive unit.
 - Changing the values of the parameters for manufacturer setting
 - Setting a value out of the range
 - Changing the fixed values in the digits of a parameter

POINT

- For the parameter converter function, refer to "Part 8: Common Reference Material".
- To enable a parameter whose abbreviation is preceded by *, turn the power OFF and then ON after setting the parameter.
- For details about parameter settings for replacement, refer to "MR-J4-_A_(-RJ)/MR-J4-03A6(-RJ) Servo Amplifier Instruction Manual" and "MR-J4-_B_(-RJ) Servo Amplifier Instruction Manual"
- With the drive unit, the deceleration to a stop function is enabled in the factory setting. To disable the deceleration to a stop function, set [Pr. PA04] to "0 ___".

5.1 Converter unit

5.1.1 Converter unit parameter comparison list

MR-J3-CR55K/MR-J3-CR55K4					MR-CR55K/MR-CR55K4				
No.	Abbreviation	Parameter name	Initial value	Customer setting value	No.	Abbreviation	Parameter name	Initial value	Customer setting value
PA01	*REG	Regenerative option	0000h		PA01	*REG	Regenerative option	0000h	
PA02	*MCC	Magnetic contactor drive output selection	0001h		PA02	*MCC	Magnetic contactor drive output selection	0001h	
PA03	\	For manufacturer setting	0001h		PA03	\	For manufacturer setting	0001h	
PA04			0		PA04			0	
PA05			100		PA05			100	
PA06			0		PA06			0	
PA07			100		PA07			100	
PA08	*DMD	Status display selection	0000h		PA08	*DMD	Status display selection	0000h	
PA09	*BPS	Alarm history clear	0000h		PA09	*BPS	Alarm history clear	0000h	
PA10	\	For manufacturer setting	0		PA10	\	For manufacturer setting	0	
PA11			0000h		PA11			0000h	
PA12	*DIF	Input filter setting	0002h		PA12	*DIF	Input filter setting	0002h	
PA13	\	For manufacturer setting	0000h		PA13	\	For manufacturer setting	0000h	
PA14			0000h		PA14			0000h	
PA15			0000h		PA15	AOP3	Function selection A-3	0000h	
PA16			0000h		PA16	\	For manufacturer setting	0000h	
PA17			0000h		PA17			*AOP5	Function selection A-5
PA18			0000h		PA18	CVAT	SEMI-F47 function - Instantaneous power failure detection time	200	
PA19			0000h		PA19	\	For manufacturer setting	0000h	

Part 5: Review on Replacement of MR-J3-DU_ with MR-J4-DU_

5.1.2 Converter unit comparison of parameter details

POINT

● Set a value to each "x" in the "Setting digit" columns.

MR-J3-CR55K/MR-J3-CR55K4			MR-CR55K/MR-CR55K4				
No.	Name and function	Initial value	No.	Name and function	Initial value		
PA01	Regenerative option Used to select the regenerative option 0 0 x x: Select the regenerative option 00: No used 01: MR-RB139 02: MR-RB137 (3 pcs.) 11: MR-RB136-4 12: MR-RB138-4 (3 pcs.) "01" and "02" are the set values for the MR-J3-CR55K only, and "11" and "12" are those for the MR-J3-CR55K4 only. Incorrect setting will trigger [AL. 37 Parameter error].	0000h	PA01	Regenerative option Select a regenerative option. __ x x: Incorrect setting will trigger [AL. 37 Parameter error]. 00: Regenerative option is not used When using the FR-BU2-(H) brake unit, select the value. 01: MR-RB139 02: MR-RB137 (3 pcs.) 13: MR-RB137-4 14: MR-RB13V-4 (3 pcs.)	00h		
						_ x _:	0h
						x _ _:	0h
PA02	Magnetic contactor drive output selection Used to select the output of the magnetic contactor drive power supply. 0 0 0 x: Used to select the output of the magnetic contactor drive power supply. 0: Disabled 1: Enabled	0001h	PA02	Magnetic contactor drive output selection Select the magnetic contactor drive output. ___ x 0: Disabled 1: Enabled	1h		
						_ _ x _:	0h
						_ x _ _:	0h
PA08	Status display selection Select a status display shown at power-on. 0 0 0 x: Status display of converter unit display section at power-on. 0: Status 1: Bus voltage 2: Effective load ratio 3: Peak load ratio 4: Regenerative load ratio	0000h	PA08	Status display selection ___ x: Select a status display shown at power-on. 0: Status 1: Bus voltage 2: Effective load ratio 3: Peak load ratio 4: Regenerative load ratio 5: Unit power consumption 1 6: Unit total power consumption 1 7: Unit total power consumption 2	0h		
						_ _ x _:	0h
						_ x _ _:	0h
PA08	Status display selection Select a status display shown at power-on. 0 0 0 x: Status display of converter unit display section at power-on. 0: Status 1: Bus voltage 2: Effective load ratio 3: Peak load ratio 4: Regenerative load ratio	0000h	PA08	Status display selection ___ x: Select a status display shown at power-on. 0: Status 1: Bus voltage 2: Effective load ratio 3: Peak load ratio 4: Regenerative load ratio 5: Unit power consumption 1 6: Unit total power consumption 1 7: Unit total power consumption 2	0h		
						_ _ x _:	0h
						x _ _:	0h

Part 5: Review on Replacement of MR-J3-DU_ with MR-J4-DU_

MR-J3-CR55K/MR-J3-CR55K4			MR-CR55K/MR-CR55K4		
No.	Name and function	Initial value	No.	Name and function	Initial value
PA09	Alarm history clear Used to clear the alarm history. 0 0 0 x: Alarm history clear 0: Invalid 1: Valid When alarm history clear is made valid, the alarm history is cleared at next power-on. After the alarm history is cleared, the setting is automatically made invalid (reset to 0).	0000h	PA09	Alarm history clear Used to clear the alarm history. ___ x: 0: Disabled 1: Enabled When you select "Enabled", the alarm history will be cleared at next power-on. After the alarm history is cleared, the setting is automatically disabled.	0h
				___ x _: For manufacturer setting	0h
				_ x _ _: For manufacturer setting	0h
				x _ _ _: For manufacturer setting	0h
PA12	Input filter setting Select the input filter. 0 0 0 x: Input signal filter If external input signal causes chattering due to noise, etc., input filter is used to suppress it. 0: None 1: 1.777 [ms] 2: 3.555 [ms] 3: 5.333 [ms]	0002h	PA12	Input filter setting Select the input filter. ___ x: If external input signal causes chattering due to noise, etc., input filter is used to suppress it. 0: None 1: 1.777 [ms] 2: 3.555 [ms] 3: 5.333 [ms]	2h
				___ x _: For manufacturer setting	0h
				_ x _ _: For manufacturer setting	0h
				x _ _ _: For manufacturer setting	0h
PA15	For manufacturer setting Do not change this value by any means.	0000h	PA15	Function selection A-3 ___ x: Selection of unit power consumption display unit 0: increment of 1 kW 1: increment of 0.1 kW	0h
				___ x _: For manufacturer setting	0h
				_ x _ _: For manufacturer setting	0h
				x _ _ _: For manufacturer setting	0h

Part 5: Review on Replacement of MR-J3-DU_ with MR-J4-DU_

MR-J3-CR55K/MR-J3-CR55K4			MR-CR55K/MR-CR55K4		
No.	Name and function	Initial value	No.	Name and function	Initial value
PA17	For manufacturer setting Do not change this value by any means.	0000h	PA17	Function selection A-5 The [Pr. PA17 SEMI-F47 function selection] and [Pr. PA18 SEMI-F47 function - Instantaneous power failure detection time] settings of the converter unit must be the same as [Pr. PA20 SEMI-F47 function selection] and [Pr. PF25 SEMI-F47 function - Instantaneous power failure detection time] settings of the drive unit. _ _ _ x: [AL. 10 Undervoltage] detection method selection Set this parameter when [AL. 10] occurs due to distorted power supply voltage waveform. 0: [AL. 10] not occurrence 1: [AL. 10] occurrence	1h
			PA17	_ _ x _: SEMI-F47 function selection 0: Disabled 1: Enabled Selecting "1" enables to avoid triggering [AL. 10 Undervoltage] using the electrical energy charged in the capacitor in case that an instantaneous power failure occurs during operation. In [Pr. PA18 SEMI-F47 function - Instantaneous power failure detection time], set the time until the occurrence of [AL. 10 Undervoltage].	0h
			PA17	_ x _ _: For manufacturer setting	0h
			PA17	x _ _ _: For manufacturer setting	0h
PA18	For manufacturer setting Do not change this value by any means.	0000h	PA18	SEMI-F47 function - Instantaneous power failure detection time The [Pr. PA17 SEMI-F47 function selection] and [Pr. PA18 SEMI-F47 function - Instantaneous power failure detection time] settings of the converter unit must be the same as [Pr. PA20 SEMI-F47 function selection] and [Pr. PF25 SEMI-F47 function - Instantaneous power failure detection time] settings of the drive unit. Set the time until the occurrence of [AL. 10 Undervoltage]. To disable the parameter setting value, select "Disabled (_ _ 0 _)" of "SEMI-F47 function selection" in [Pr. PA17]. Setting range: 30 to 200	200 [ms]

Part 5: Review on Replacement of MR-J3-DU_ with MR-J4-DU_

5.2 Drive unit

POINT
<ul style="list-style-type: none"> ● Manufacturer setting parameters are not described here. ● Set a value to each "x" in the "Setting digit" columns. ● An incorrect setting may cause the regenerative option to burn out. ● When a regenerative option that is not available to use on a servo amplifier is selected, a [AL.37 parameter error] occurs. ● For a drive unit of 30 kW or more, be sure to set this parameter to "__ 0 0" since selecting the regenerative option and brake unit is carried out by [Pr. PA01] of the MR-J3-CR55K(4) converter unit.

5.2.1 Drive unit comparison of parameter details

(1) General-Purpose interface 200 V/400 V class

Here are described settings of drive unit specific parameters. Settings of the other parameters are the same as MR-J4-_A_(-RJ). Refer to "Part 2: section 3.5".

MR-J3-DU A			MR-J4-DU A		
No.	Name and function	Initial value	No.	Name and function	Initial value
PA02	Regenerative option Set this parameter when using the regenerative option, brake unit, power regenerative converter, or power regenerative common converter. 0 0 x x: Selection of regenerative option 00: Regenerative option is not used, or when you use a regenerative option, set the regenerative option with the converter unit. When using the drive unit with the converter unit, set this value regardless of whether or not the regenerative option and brake unit are used.)	0000h	PA02	Regenerative option __ x X: Select a regenerative option. For the drive unit, select the regenerative option with the converter unit. Selecting other than "__ 0 0" or "__ 0 1" will trigger [AL.37 Parameter error]. 00: Regenerative option is not used, or when you use a regenerative option, set the regenerative option with the converter unit. When using the drive unit with the converter unit, set this value regardless of whether or not the regenerative option and brake unit are used.)	00h
				_ x __: For manufacturer setting	0h
				x __ __: For manufacturer setting	0h

Part 5: Review on Replacement of MR-J3-DU_ with MR-J4-DU_

(2) SSCNET interface 200 V/400 V class

POINT
<ul style="list-style-type: none"> ● When you connect the amplifier to a servo system controller, servo parameter values of the servo system controller will be written to each parameter. ● Setting may not be made to some parameters and their ranges depending on the servo system controller model, drive unit software version, and MR Configurator2 software version. For details, refer to the servo system controller user's manual.

Here are described settings of drive unit specific parameters. Settings of the other parameters are the same as MR-J4-_B_. Refer to "Part 3: section 3.6".

MR-J3-DU_B_			MR-J4-DU_B_		
No.	Name and function	Initial value	No.	Name and function	Initial value
PA02	Regenerative option Set this parameter when using the regenerative option, brake unit, power regeneration converter, or power regeneration common converter. 0 0 x x: Selection of regenerative option 00: Regenerative option is not used, or when you use a regenerative option, set the regenerative option with the converter unit. When using the drive unit with the converter unit, set this value regardless of whether or not the regenerative option and brake unit are used.)	0000h	PA02	Regenerative option Select a regenerative option. For the drive unit, select the regenerative option with the converter unit. Selecting other than "__ 0 0" or "__ 0 1" will trigger [AL. 37 Parameter error]. __ x x: Regenerative option selection 00: Regenerative option is not used, or when you use a regenerative option, set the regenerative option with the converter unit. When using the drive unit with the converter unit, set this value regardless of whether or not the regenerative option and brake unit are used.)	0h
				_ x _ : Converter unit selection 0: MR-CR_ 7: MR-CV_ Setting a value other than "0" or "7" will trigger [AL. 37].	0h
				x _ _ : Enable or disable the protection coordination mode. 0: Protection coordination mode enabled 4: Protection coordination mode disabled (stand-alone drive) Set "4" for the drive unit which is not connected to the MR-CV_ with the protection coordination cable. To disable the protection coordination mode, set "Protection coordination mode function between converter and drive unit selection" of [Pr. PF03] to "Enabled (_ 1 _)", and then this parameter to "Protection coordination mode disabled (4 _ _)".	0h

6. CHARACTERISTICS

6.1 Overload protection characteristics

An electronic thermal relay is built in the converter unit and drive unit to protect the servo motor, converter unit and drive unit from overloads.

[AL. 50 Overload 1] occurs if overload operation performed is above the electronic thermal protection curve shown in fig. 5.1, 5.2 and 5.3. [AL. 51 Overload 2] occurs if the maximum current is applied continuously for several seconds due to machine collision, etc. Use the equipment on the left-side area of the graph.

For the system where the unbalanced torque occurs, such as a vertical axis system, the unbalanced torque of the machine should be kept at 70% or lower of the motor's rated torque.

The MR-J3-DU_ and MR-J4-DU_ servo amplifiers have servo motor overload protective function.

(1) For the MR-J3-DU_

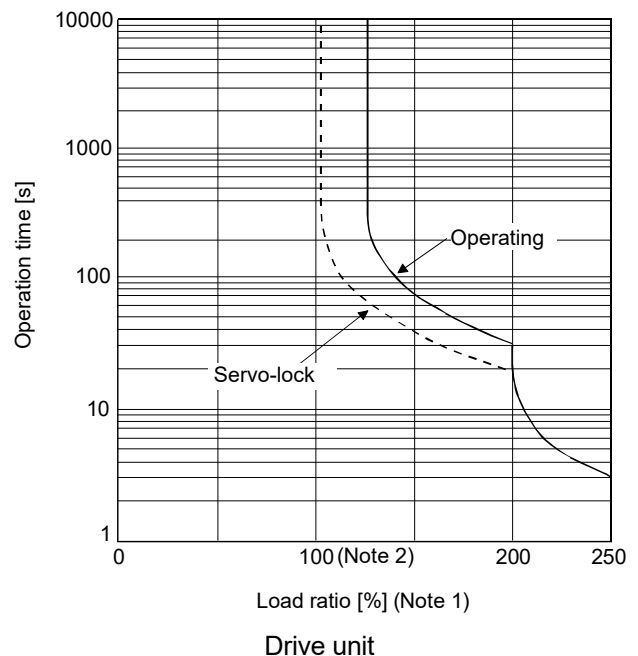
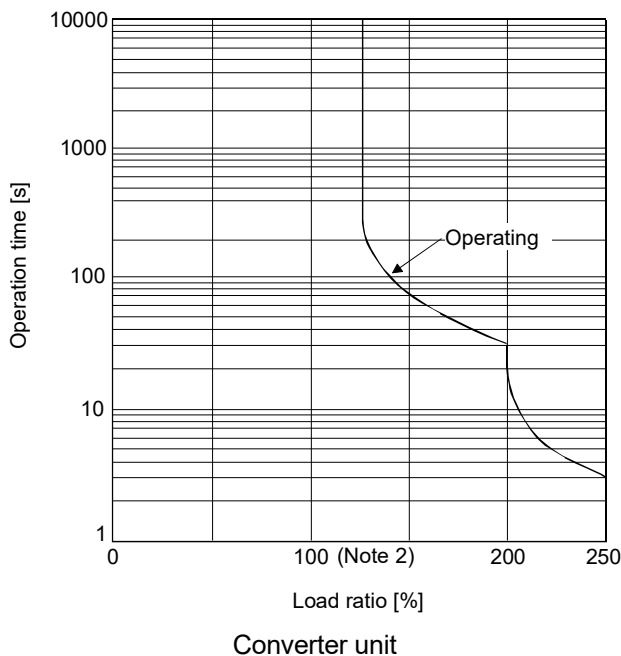

- Note 1. If operation that generates torque more than 100% of the rating is performed with an abnormally high frequency in a servo motor stop status (servo-lock status) or in a 30 r/min or less low-speed operation status, the drive unit may malfunction regardless of the electronic thermal protection.
- Note 2. Load ratio 100% indicates the rated output of each converter unit and drive unit. Refer to "MR-J4-_A_(-RJ)/MR-J4-03A6(-RJ) Servo Amplifier Instruction Manual", "MR-J4-_B_(-RJ) Servo Amplifier Instruction Manual" and "MR-CV_/MR-CR55K_/MR-J4-DU_B_(-RJ)/MR-J4-DU_A_(-RJ) Instruction Manual".

Fig. 5.1 Overload protection characteristics

Part 5: Review on Replacement of MR-J3-DU_ with MR-J4-DU_

(2) For the MR-J4-DU_

The following table shows combinations of each servo motor and graph of overload protection characteristics.

Rotary servo motor		Graph
HG-SR	HG-JR	
702 7024	503 703 701M 5034 7034	Characteristics A
	11K1M 903 9034 12K14 11K1M4 15K1M4 37K14 12K1 37K1 15K1M 801 15K1 20K1 25K1 30K1 22K1M 30K1M 37K1M 8014 15K14 20K14 25K14 30K14 22K1M4 30K1M4 37K1M4 45K1M4	Characteristics B
	601 6014 701M4	Characteristics A
	55K1M4	Characteristics B

Part 5: Review on Replacement of MR-J3-DU_ with MR-J4-DU_

The following graphs show overload protection characteristics.

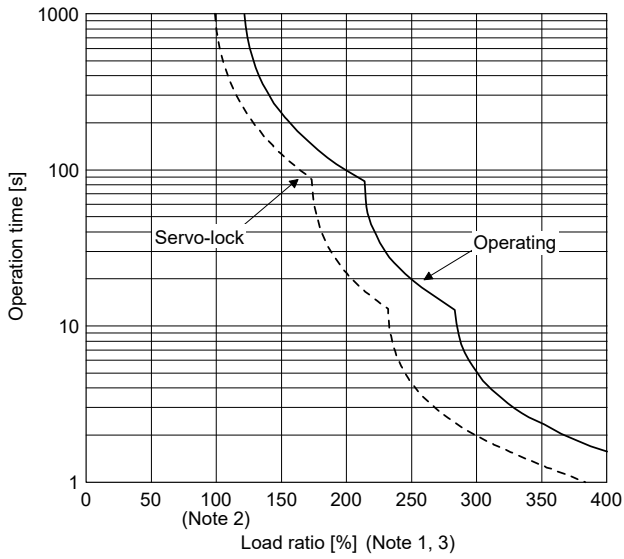

Characteristics A

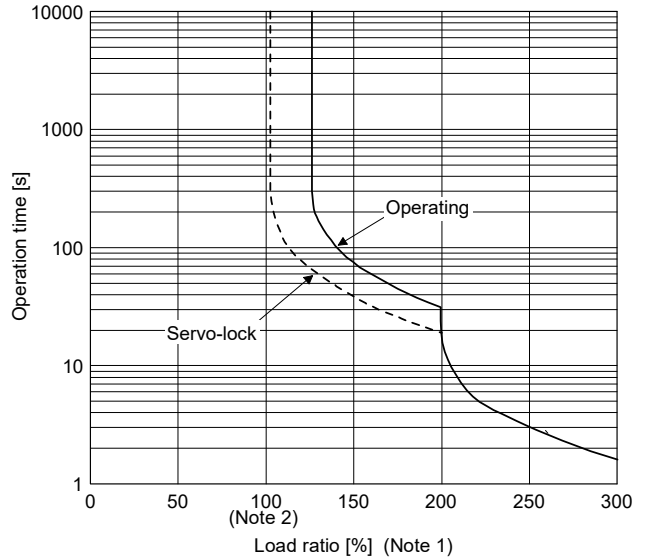

Characteristics B

- Note 1. If operation that generates torque more than 100% of the rating is performed with an abnormally high frequency in a servo motor stop status (servo-lock status) or in a 50 r/min or less low-speed operation status, the drive unit may malfunction regardless of the electronic thermal protection.
- Note 2. Load ratio 100% indicates the rated output of the drive unit. Refer to "MR-CV_/MR-CR55K_/MR-J4-DU_B_(-RJ)/MR-J4-DU_A_(-RJ) Instruction Manual".
- Note 3. The operation time at the load ratio of 300% to 400% applies when the maximum torque is increased to 400% of rated torque. For the combination of a servo amplifier and servo motor with which the maximum torque can be increased, refer to "Part 1: 3.2.2(3) Servo amplifier and servo motor combination for the MR-J4 series".

Fig. 5.2 Overload protection characteristics.

(3) For the MR-CR_ converter unit

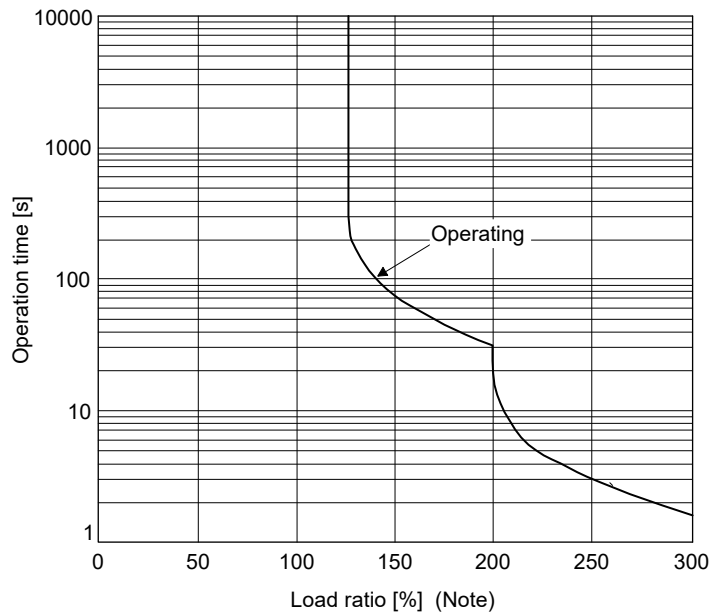

Note. Load ratio 100% indicates the rated output of the converter unit. Refer to "MR-CV_/MR-CR55K_/MR-J4-DU_B_(-RJ)/MR-J4-DU_A_(-RJ) Instruction Manual".

Fig. 5.3 Overload protection characteristics

Part 5: Review on Replacement of MR-J3-DU_ with MR-J4-DU_

6.2 Power supply capacity and generated loss

(1) Generated heat of the converter unit/drive unit

Table 5.1 and 5.2 indicates the generated loss and power supply capacity under rated load per combination of the converter unit and drive unit. When the servo motors are run at less than the rated speed, the power supply equipment capacity is lower than the value in the table but the heat generated does not change.

Since the servo motor requires 2 times to 2.5 times greater instantaneous power for acceleration, use the power supply which ensures that the voltage lies within the permissible voltage fluctuation at the main circuit power supply terminals (L1/L2/L3) of the converter unit. The power supply equipment capacity changes with the power supply impedance. The actually generated heat falls within the ranges at rated output and at servo-off according to the frequencies of use during operation. When designing an enclosed cabinet, use the values in the table, considering the worst operating conditions. The generated heat in table 5.1 and 5.2 does not include heat produced during regeneration.

(a) MR-J3-DU_

Table 5.1 Power supply capacity and generated heat per servo amplifier at rated output

Converter unit	Drive unit	Servo motor	Power supply capacity [kVA]		Drive unit-generated heat [W] (Note)			Area required for heat dissipation [m ²]
			Power factor improving DC reactor is not used	Power factor improving DC reactor is used	At rated torque	At rated output [Generated heat in the cabinet when cooled outside the cabinet]	At zero torque	
MR-J3-CR55K	MR-J3-DU30K_	HA-LP30K1 HA-LP30K1M HA-LP30K2	48	40	1550 (1100 + 450)	470	60 (30 + 30)	31.0
	MR-J3-DU37K_	HA-LP37K1 HA-LP37K1M HA-LP37K2	59	49	1830 (1280 + 550)	550		36.6
MR-J3-CR55K4	MR-J3-DU30K_4	HA-LP25K14	40	35	1080 (850 + 230)	330		21.6
		HA-LP30K14 HA-LP30K1M4 HA-LP30K24	48	40	1290 (1010 + 280)	390		25.8
	MR-J3-DU37K_4	HA-LP37K14 HA-LP37K1M4 HA-LP37K24	59	49	1542 (1200 + 342)	470		30.8
	MR-J3-DU45K_4	HA-LP45K1M4 HA-LP45K24	71	59	1810 (1370 + 440)	550		36.2
	MR-J3-DU55K_4	HA-LP50K1M4	80	67	2120 (1650 + 470)	640	42.4	
		HA-LP55K24	87	72	2150 (1650 + 500)	650	43.0	

Note. The heat generated by the drive unit is indicated in the left term within the parentheses, and the heat generated by the converter unit in the right term.

Part 5: Review on Replacement of MR-J3-DU_ with MR-J4-DU_

(b) MR-J4-DU_

Table 5.2 Power supply capacity and generated heat per servo motor at rated output

Converter unit	Drive unit	Servo motor	Power supply capacity [kVA]		Drive unit-generated heat [W] (Note)			Area required for heat dissipation [m ²]
			Power factor improving DC reactor is not used	Power factor improving DC reactor is used	At rated output	At rated output [Generated heat in the cabinet when cooled outside the cabinet]	With servo-off	
MR-CR55K	MR-J4-DU30K_	HG-JR30K1 HG-JR30K1M	48	40	1350 (900 + 450)	470	60 (30 + 30)	27.0
	MR-J4-DU37K_	HG-JR37K1 HG-JR37K1M	59	49	1550 (1000 + 550)	550		31.0
MR-CR55K4	MR-J4-DU30K_4	HG-JR30K14 HG-JR30K1M4	48	40	1070 (790 + 280)	390		21.4
	MR-J4-DU37K_4	HG-JR37K14 HG-JR37K1M4	59	49	1252 (910 + 342)	470		25.1
	MR-J4-DU45K_4	HG-JR45K1M4	71	59	1580 (1110 + 470)	550		31.6
	MR-J4-DU55K_4	HG-JR55K1M4	87	72	1940 (1440 + 500)	650		38.8

Note. The heat generated by the drive unit is indicated in the left term within the parentheses, and the heat generated by the converter unit in the right term.

Part 5: Review on Replacement of MR-J3-DU_ with MR-J4-DU_

6.3 Inrush currents at power-on of main circuit/control circuit

POINT	
●	The inrush current values can change depending on frequency of turning on/off the power and ambient temperature.

Since large inrush currents flow in the power supplies, always use molded-case circuit breakers and magnetic contactors. (Refer to section 7.3.)

When circuit protectors are used, it is recommended that the inertia delay type, which is not tripped by an inrush current, be used.

(1) MR-J3 series

The following table indicates the inrush currents (reference data) that will flow when the maximum permissible voltage (200 V class: 253 VAC, 400 V class: 528 VAC) is applied at the power supply capacity of 2500 kVA and the wiring length of 1 m.

Converter unit	Drive unit	Inrush currents (A _{0-P})	
		Main circuit power supply (L ₁ /L ₂ /L ₃)	Control circuit power supply (L ₁₁ /L ₂₁)
MR-J3-CR55K	MR-J3-DU30K_	163 A	18 A
	MR-J3-DU37K_	(Attenuated to approx. 20 A in 180 ms)	(Attenuated to approx. 0 A in 100 ms)
MR-J3-CR55K4	MR-J3-DU30K_4	339 A (Attenuated to approx. 20 A in 70 ms)	19 A (Attenuated to approx. 0 A in 60 ms)
	MR-J3-DU37K_4		
	MR-J3-DU45K_4		
	MR-J3-DU55K_4		

(2) MR-J4 series

The following table indicates the inrush currents (reference data) that will flow when the maximum permissible voltage (200 V class: 240 V AC, 400 V class: 480 V AC) is applied at the power supply capacity of 2500 kVA and the wiring length of 1 m.

Converter unit	Drive unit	Inrush currents (A _{0-P})	
		Main circuit power supply (L ₁ /L ₂ /L ₃)	Control circuit power supply (L ₁₁ /L ₂₁)
MR-CR55K	MR-J4-DU30K_	154 A	31 A
	MR-J4-DU37K_	(Attenuated to approx. 20 A in 150 ms)	(Attenuated to approx. 2 A in 60 ms)
MR-CR55K4	MR-J4-DU30K_4	305 A (Attenuated to approx. 20 A in 70 ms)	27 A (Attenuated to approx. 2 A in 45 ms)
	MR-J4-DU37K_4		
	MR-J4-DU45K_4		
	MR-J4-DU55K_4		

Part 5: Review on Replacement of MR-J3-DU_ with MR-J4-DU_

7. OPTIONS AND PERIPHERAL EQUIPMENT

7.1 Comparison table of cable option combinations

Cable option combinations

Application	MR-J3-DU_	MR-J4-DU_	Compatibility (Note 4)	Note
Encoder cable	MR-J3ENSCBL_M_- Cable length: 2 m/5 m/10 m/20 m/30 m	MR-ENECBL_M-H-MTH Cable length: 2 m/5 m/10 m/20 m/30 m/40 m/50 m	×	When connected to an HG-JR motor, the encoder cable needs to be changed.
Encoder connector set	MR-J3SCNS	MR-ENECNS	×	When connected to an HG-JR motor, the encoder cable needs to be changed.
SSCNET optical communication cable	MR-J3BUS_M Cable length: 0.15 to 3 m		○	Use the same combination.
	MR-J3BUS_M-A Cable length: 5 to 20 m			
	MR-J3BUS_M-B Cable length: 30 to 50 m			
General-purpose interface I/O signal CN1 connector set	MR-J3CN1		○	Use the same combination.
SSCNET interface I/O signal CN3 connector set	MR-CCN1		○	Use the same combination.
CN5 communication cable	MR-J3USBCBL3M		○	Use the same combination.
Battery for junction battery cable	MR-J3BTCBL03M	MR-BT6VCBL03M	(Note 1)	Use the dedicated battery f each series.
Monitor cable	MR-J3CN6CBL1M		○	Use the same combination.
Protection coordination cable	MR-J3CDL05M		○	Use the same combination.
CN40/CN40A connector set	MR-J2CN1-A		○	Use the same combination.
Termination connector	MR-J3-TM		○	Not required
Magnetic contactor wiring connector	(Note 2)		○	Socket: GFKC 2.5/2-STF-7.62
Digital I/O connector			○	Connector 17JE23090-02(D8A)K11-CG
STO cable		MR-D05UDL3M-B	(Note 3)	When not using the STO function, attach the short-circuit connector supplied with the drive unit to CN8 (STO I/O signal connector).
RS-422/RS-232C conversion cable	DSV-CABV		○	Use the same combination.

- Note
1. Use the dedicated battery of each series.
 2. Supplied with converter unit.
 3. MR-D05UDL3M-B is in production.
 4. ○ : Compatible, △ : Compatible with condition, × : Not compatible

Part 5: Review on Replacement of MR-J3-DU_ with MR-J4-DU_

7.1.1 MR-J3CDL05M (0.5 m) Protection coordination cable

	CAUTION	● Connect protection coordination cables correctly if they are fabricated. Otherwise, the system may perform unexpected operation.
---	---------	--

POINT	● MR-J3CDL05M is for the MR-CR_ converter unit. MR-J3CDL05M cannot be used with the MR-CV_ power regeneration converter unit.
-------	--

(1) Applications of the protection coordination cable
The cable is used to connect a converter unit to a drive unit.

(2) Internal wiring diagram

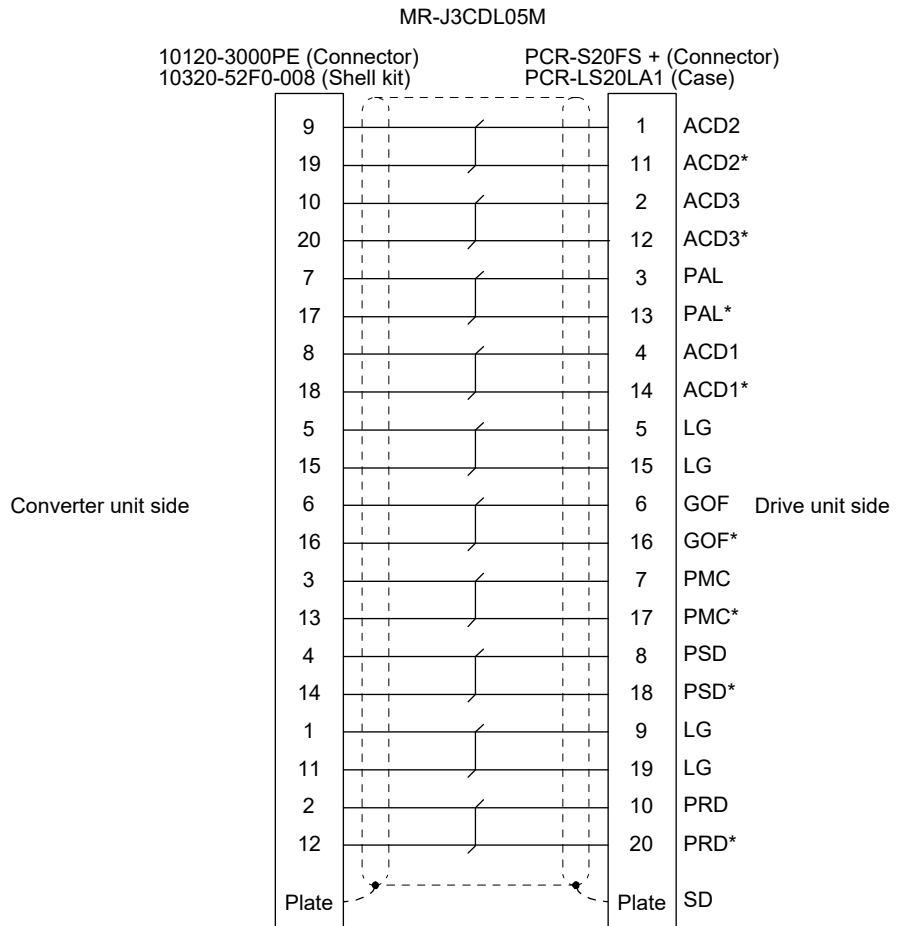

Part 5: Review on Replacement of MR-J3-DU_ with MR-J4-DU_

(3) When fabricating a cable

Prepare MR-J2CN1-A connector set, the recommended wires, and fabricate the cable according to the wiring diagram in (2) in this section.

Model	Length [m]	Core size [mm ²]	Number of cores	Characteristics of one core			Cable OD [mm] (Note 2)	Wire model
				Structure [Wires/mm]	Conductor resistance [Ω/km]	Insulator OD d [mm] (Note 1)		
MR-J3CDL05M	0.5	0.08	20 (10 pairs)	7/0.127	222 or less	0.38	6.1	UL 20276 AWG#28 10pair (cream)

Note 1. The following shows the detail of d.

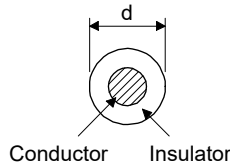

2. Standard OD. Maximum OD is about 10% greater.

7.2 Selection example of wires

POINT
<ul style="list-style-type: none"> To comply with the IEC/EN/UL/CSA standard, use the wires refer to "MR-J4-_A_(-RJ)/MR-J4-03A6(-RJ) Servo Amplifier Instruction Manual", "MR-J4-_B_(-RJ) Servo Amplifier Instruction Manual" and "MR-CV_/MR-CR55K_/MR-J4-DU_B_(-RJ)/MR-J4-DU_A_(-RJ) Instruction Manual". To comply with other standards, use a wire that is complied with each standard. Selection conditions of wire size are as follows. <ul style="list-style-type: none"> Construction condition: Single wire set in midair Wire length: 30 m or less (J3 series) 50 m or less (J4 series)

7.2.1 MR-J3 series, power supply wire size

For the power supply wire, use a 600 V grade heat-resistant polyvinyl chloride insulated wire (HIV wire). The following diagram shows the wires used for wiring. Use the wires or equivalent given in this section.

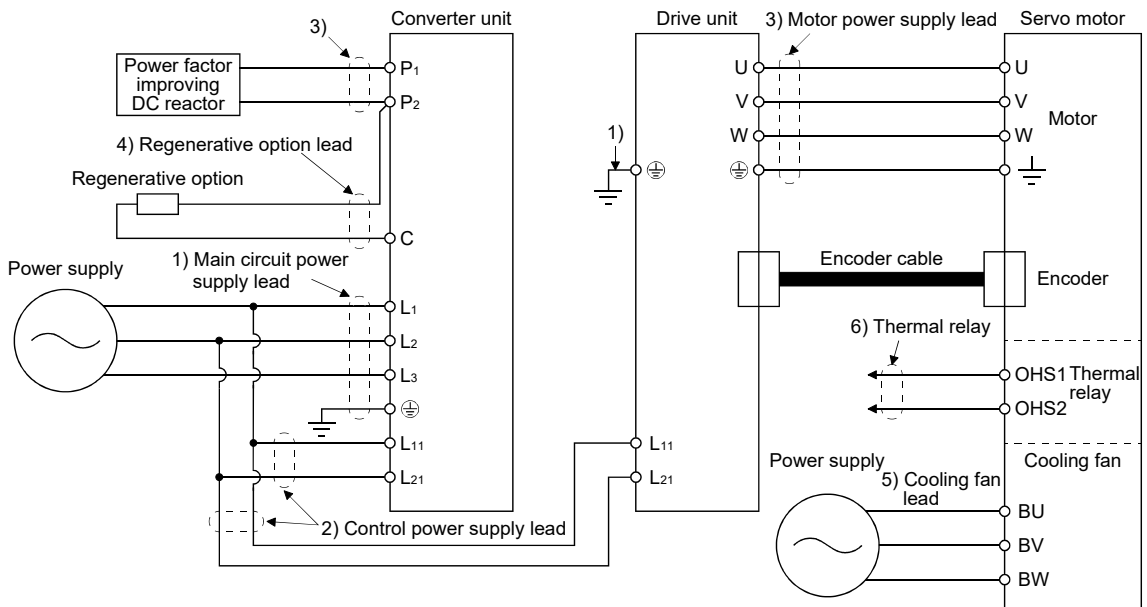

Part 5: Review on Replacement of MR-J3-DU_ with MR-J4-DU_

- (1) When using the 600V Grade heat-resistant polyvinyl chloride insulated wire (HIV wire)
Selection example of wire size when using HIV wires is indicated below.

Wire size selection example 2 (HIV wire)

Converter unit	Drive unit (Note 2)	Wires [mm ²] (Note 1, 3)					
		1) L ₁ /L ₂ /L ₃ /⊕	2) L ₁₁ /L ₂₁	3) U/V/W/P ₁ /P ₂ /⊕	4) P ₂ /C	5) BU/BV/BW	6) OHS1/OHS2
MR-J3-CR55K	MR-J3-DU30K_	38 (AWG2): c	2 (AWG14)	60 (AWG2/0): d	5.5 (AWG10): a	2 (AWG14)	1.25 (AWG16)
	MR-J3-DU37K_	60 (AWG2/0): d		60 (AWG2/0): d			
MR-J3-CR55K4	MR-J3-DU30K_4	22 (AWG4): b		22 (AWG4): e		1.25 (AWG16)	
	MR-J3-DU37K_4	22 (AWG4): b		22 (AWG4): e			
	MR-J3-DU45K_4	38 (AWG2): c		38 (AWG2): c			
	MR-J3-DU55K_4	38 (AWG2): c		38 (AWG2): c			

- Note 1. Alphabets in the table indicate crimping tools. For crimp terminals and applicable tools, refer to (2) in this section.
2. To connect these models to a terminal block, be sure to use the screws that come with the terminal block.
3. Wires are selected based on the highest rated current among combining servo motors.

- (2) Selection example of crimp terminals

The following shows the selection example of crimp terminals for terminal blocks of the drive unit and converter unit when you use wires mentioned in (1) in this section.

Symbol	Drive unit/converter unit-side crimp terminal				Manufacturer
	Crimp terminal (Note 2)	Applicable tool			
		Body	Head	Dice	
a	FVD5.5-10	YNT-1210S			JST (J.S.T. Mfg. Co., Ltd.)
b	FVD22-10	YF-1 E-4	YNE-38	DH-123 DH-113	
c (Note 1)	R38-10	YPT-60-21		TD-124	
		YF-1 E-4	YET-60-1	TD-112	
d (Note 1)	R60-10	YPT-60-21		TD-125	
		YF-1 E-4	YET-60-1	TD-113	
e	FVD22-8	YF-1 E-4	YNE-38	DH-123 DH-113	
f (Note 1)	R38-8	YPT-60-21		TD-124	
		YF-1 E-4	YET-60-1	TD-112	

- Note 1. Coat the crimping part with an insulation tube.
2. Some crimp terminals may not be mounted. Make sure to use the recommended crimp terminal or one equivalent to it.

Part 5: Review on Replacement of MR-J3-DU_ with MR-J4-DU_

7.2.2 MR-J4 series, power supply wire size

The following diagram shows the wires used for wiring. Use the wires given in this section or equivalent.

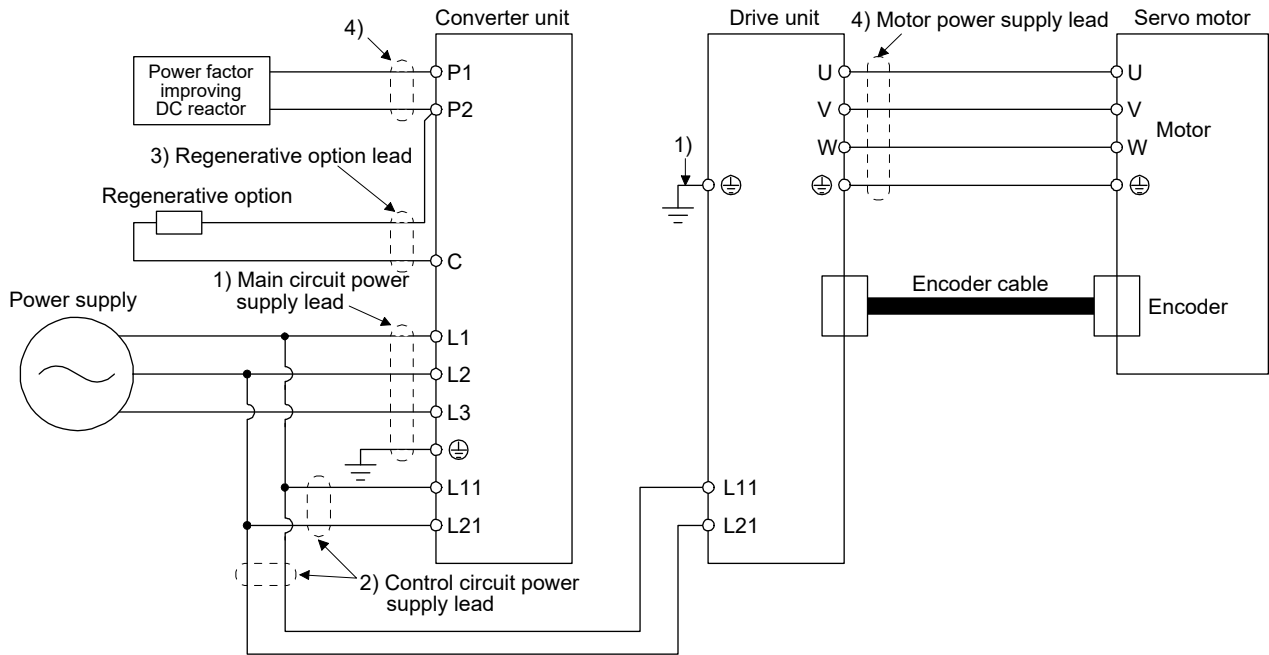

(1) Example of selecting the wire sizes

Use the 600 V grade heat-resistant polyvinyl chloride insulated wire (HIV wire) for wiring. The following shows the wire size selection example.

Wire size selection example (HIV wire)
Recommended wire

Converter unit (Note 2)	Drive unit (Note 2)	Wire [mm ²] (Note 1, 3)			
		1) L1/L2/L3/⊕	2) L11/L21	3) P2/C	4) U/V/W P1/P2/⊕
MR-CR55K	MR-J4-DU30K_	38 (AWG2): c	1.25 to 2 (AWG 16 to 14): g (Note 4)	5.5 (AWG10): a	60 (AWG2/0): d
	MR-J4-DU37K_	60 (AWG2/0): d			60 (AWG2/0): d
MR-CR55K4	MR-J4-DU30K_4	22 (AWG4): e			22 (AWG4): e
	MR-J4-DU37K_4	22 (AWG4): e			38 (AWG 2): f
	MR-J4-DU45K_4	38 (AWG2): c			38 (AWG2): c
	MR-J4-DU55K_4	38 (AWG2): c	38 (AWG2): c		

- Note
1. Alphabets in the table indicate crimping tools. For crimp terminals and applicable tools, refer to (2) in this section.
 2. To connect these models to a terminal block, be sure to use the screws that come with the terminal block.
 3. Wires are selected based on the highest rated current among combining servo motors.
 4. Be sure to use the size of 2 mm² when corresponding to the IEC/EN/UL/CSA standard.

Part 5: Review on Replacement of MR-J3-DU_ with MR-J4-DU_

(2) Selection example of crimp terminals

The following shows the selection example of crimp terminals for terminal blocks of the drive unit and converter unit when you use wires mentioned in (1) in this section.

Symbol	Drive unit/converter unit-side crimp terminal				Manufacturer
	Crimp terminal (Note 2)	Applicable tool			
		Body	Head	Dice	
a	FVD5.5-10	YNT-1210S			JST (J.S.T. Mfg. Co., Ltd.)
b	FVD22-10	YF-1 E-4	YNE-38	DH-123 DH-113	
c (Note 1)	R38-10	YPT-60-21		TD-124	
		YF-1 E-4	YET-60-1	TD-112	
d (Note 1)	R60-10	YPT-60-21		TD-125	
		YF-1 E-4	YET-60-1	TD-113	
e	FVD22-8	YF-1 E-4	YNE-38	DH-123 DH-113	
f (Note 1)	R38-8	YPT-60-21		TD-124	
		YF-1 E-4	YET-60-1	TD-112	
g	FVD2-4	YNT-1614			

- Note 1. Coat the crimping part with an insulation tube.
 Note 2. Installation of a crimp terminal may be impossible depending on the size, so make sure to use the recommended crimp terminal or one equivalent to it.

Part 5: Review on Replacement of MR-J3-DU_ with MR-J4-DU_

7.3 Selection of Molded-case circuit breakers, fuses, magnetic contactors (example)

 CAUTION	<ul style="list-style-type: none"> ● To prevent the converter unit and the drive unit from smoke and a fire, select a molded-case circuit breaker which shuts off with high speed.
	<ul style="list-style-type: none"> ● Always use one molded-case circuit breaker and one magnetic contactor with one converter unit.
	<ul style="list-style-type: none"> ● Since recommended products vary between MR-J3-DU and MR-J4-DU_, use the recommended products of MR-J4-DU_.

7.3.1 MR-J3-DU_ Molded-case circuit breakers, fuses, magnetic contactors (recommended)

(1) For main circuit power supply

When using a fuse instead of the molded-case circuit breaker, use the one having the specifications given in this section.

Converter unit	Drive unit	Molded-case circuit breaker			Fuse			Magnetic contactor (Note)
		Frame, rated current		Voltage AC [V]	Class	Current [A]	Voltage AC [V]	
		Power factor improving DC reactor is not used	Power factor improving DC reactor is used					
MR-J3-CR55K	MR-J3-DU30K_	400 A frame 250 A	225 A frame 225 A	240	T	500	300	S-N150
	MR-J3-DU37K_	400 A frame 300 A	400 A frame 300 A			600		S-N180
MR-J3-CR55K4	MR-J3-DU30K_4	225 A frame 125 A	225 A frame 125 A	600Y/347		250	600	S-N95
	MR-J3-DU37K_4	225 A frame 150 A	225 A frame 150 A			300		S-N125
	MR-J3-DU45K_4	225 A frame 175 A	225 A frame 175 A			400		S-N150
	MR-J3-DU55K_4	400 A frame 225 A	225 A frame 225 A			450		S-N180

Note. Use a magnetic contactor with an operation delay time (interval between current being applied to the coil until closure of contacts) of 80 ms or less.

7.3.2 MR-J4-DU_ Molded-case circuit breakers, fuses, magnetic contactors (recommended)

(1) For main circuit power supply

When using a fuse instead of the molded-case circuit breaker, use the one having the specifications given in this section.

Converter unit	Drive unit	Molded-case circuit breaker (Note 1)			Fuse			Magnetic contactor (Note 2)
		Frame, rated current		Voltage AC [V]	Class	Current [A]	Voltage AC [V]	
		Power factor improving DC reactor is not used	Power factor improving DC reactor is used					
MR-CR55K	MR-J4-DU30K_	225 A frame 175 A	225 A frame 150 A	240	T	300	300	S-N150
	MR-J4-DU37K_	225 A frame 225 A	225 A frame 175 A			400		S-N180
MR-CR55K4	MR-J4-DU30K_4	100 A frame 100 A	100 A frame 80 A	480		175	600	S-N65
	MR-J4-DU37K_4	125 A frame 125 A	100 A frame 100 A			200		S-N80
	MR-J4-DU45K_4	225 A frame 150 A	125 A frame 125 A			300		S-N95
	MR-J4-DU55K_4	225 A frame 175 A	225 A frame 150 A			300		S-N150

Note 1. For compliance with the IEC/EN/UL/CSA standard, refer to "MR-CV_/MR-CR55K_/MR-J4-DU_B_(-RJ)/MR-J4-DU_A_(-RJ) Instruction Manual".

2. Use a magnetic contactor with an operation delay time (interval between current being applied to the coil until closure of contacts) of 80 ms or less.

Part 5: Review on Replacement of MR-J3-DU_ with MR-J4-DU_

(2) For control circuit power supply

When the wiring for the control circuit power supply (L11/L21) is thinner than that for the main circuit power supply (L1/L2/L3), install an overcurrent protection device (molded-case circuit breaker or fuse) to protect the branch circuit.

(a) Converter unit

Converter unit	Molded-case circuit breaker (Note)		Fuse (Class T)		Fuse (Class K5)	
	Frame, rated current	Voltage AC [V]	Current [A]	Voltage AC [V]	Current [A]	Voltage AC [V]
MR-CR55K	30 A frame 5 A	240	1	300	1	250
MR-CR55K4	30 A frame 5 A	480	1	600	1	600

Note. When having the converter unit comply with the IEC/EN/UL/CSA standard, refer to "MR-CV_/MR-CR55K_/MR-J4-DU_B_(-RJ)/MR-J4-DU_A_(-RJ) Instruction Manual".

(b) Drive unit

Drive unit	Molded-case circuit breaker (Note)		Fuse (Class T)		Fuse (Class K5)	
	Frame, rated current	Voltage AC [V]	Current [A]	Voltage AC [V]	Current [A]	Voltage AC [V]
MR-J4-DU30K_	30 A frame 5 A	240	1	300	1	250
MR-J4-DU37K_						
MR-J4-DU30K_4	30 A frame 5 A	480	1	600	1	600
MR-J4-DU37K_4						
MR-J4-DU45K_4						
MR-J4-DU55K_4						

Note. When having the drive unit comply with the IEC/EN/UL/CSA standard, refer to "MR-CV_/MR-CR55K_/MR-J4-DU_B_(-RJ)/MR-J4-DU_A_(-RJ) Instruction Manual".

7.4 FR-BU2-(H) brake unit

POINT									
	<ul style="list-style-type: none"> ● EM2 of the drive unit is the signal having the same contents as EM1 of the drive unit in torque control mode. (J4 series) ● Use a 200 V class brake unit and a resistor unit with a 200 V class converter unit, and a 400 V class brake unit and a resistor unit with a 400 V class converter unit. Combination of different voltage class units cannot be used. ● When a brake unit and a resistor unit are installed horizontally or diagonally, the heat dissipation effect diminishes. Install them on a flat surface vertically. ● The temperature of the resistor unit case will be higher than the ambient temperature by 100 °C or over. Keep cables and flammable materials away from the case. ● Ambient temperature condition of the brake unit is between -10 °C and 50 °C. Note that the condition is different from the ambient temperature condition of the converter unit (between 0 °C and 55 °C). ● Configure the circuit to shut down the power-supply with the alarm output of the brake unit and the resistor unit under abnormal condition. ● Use the brake unit with a combination indicated in section 7.4.1. ● Brake unit and regenerative options (Regenerative resistor) cannot be used simultaneously. ● When using the brake unit, set the parameters as follows. 								
	<table border="1" style="margin: auto; border-collapse: collapse;"> <thead> <tr> <th style="width: 70%;">Parameter</th> <th style="width: 30%;">Setting value</th> </tr> </thead> <tbody> <tr> <td>[Pr. PA01] of the converter unit</td> <td style="text-align: center;">__ 0 0 (Initial value)</td> </tr> <tr> <td>MR-J3-DU_ drive unit of the [Pr. PA02]</td> <td style="text-align: center;">__ 0 0 (Initial value)</td> </tr> <tr> <td>MR-J4-DU_ drive unit of the [Pr. PA02]</td> <td style="text-align: center;">__ 0 1</td> </tr> </tbody> </table>	Parameter	Setting value	[Pr. PA01] of the converter unit	__ 0 0 (Initial value)	MR-J3-DU_ drive unit of the [Pr. PA02]	__ 0 0 (Initial value)	MR-J4-DU_ drive unit of the [Pr. PA02]	__ 0 1
Parameter	Setting value								
[Pr. PA01] of the converter unit	__ 0 0 (Initial value)								
MR-J3-DU_ drive unit of the [Pr. PA02]	__ 0 0 (Initial value)								
MR-J4-DU_ drive unit of the [Pr. PA02]	__ 0 1								

Connect the brake unit to the bus of the converter unit (L+ and L- of TE2-1) for use. As compared to the MR-RB regenerative option, the brake unit can return larger power. Use the brake unit when the regenerative option cannot provide sufficient regenerative capability.

When using the brake unit, always refer to "FR-BU2 Brake Unit Instruction Manual".

7.4.1 Selection

Use a combination of converter unit, brake unit and resistor unit listed below.

Brake unit		Resistor unit	Number of connected units	Permissible continuous power [kW]	Resultant resistance [Ω]	Converter unit
200 V class	FR-BU2-55K	FR-BR-55K	2 (parallel)	7.82	1	MR-J3-CR55K
		MT-BR5-55K	2 (parallel)	11.0	1	MR-CR55K
400 V class	FR-BU2-H55K	FR-BR-H55K	2 (parallel)	7.82	4	MR-J3-CR55K4
	FR-BU2-H75K	MT-BR5-H75K	2 (parallel)	15.0	3.25	MR-CR55K4

Part 5: Review on Replacement of MR-J3-DU_ with MR-J4-DU_

7.4.2 Brake unit parameter setting

Normally, changing the FR-BU2-(H) parameter is not required. Whether a parameter can be changed or not is listed below.

Parameter		Change possible/ impossible	Remark
No.	Name		
0	Brake mode switchover	Impossible	Do not change the parameter.
1	Monitor display data selection	Possible	Refer to "FR-BU2 Brake Unit Instruction Manual".
2	Input terminal function selection 1	Impossible	Do not change the parameter.
3	Input terminal function selection 2		
77	Parameter write selection		
78	Cumulative energization time carrying-over times		
CLr	Parameter clear		
ECL	Alarm history clear		
C1	For manufacturer setting		

7.4.3 Connection example

POINT
<ul style="list-style-type: none"> ● Connecting PR terminal of the brake unit to L+ terminal of the converter unit results in a brake unit malfunction. Always connect the PR terminal of the brake unit to the PR terminal of the resistor unit.

(1) Combination with FR-BR-(H) resistor unit

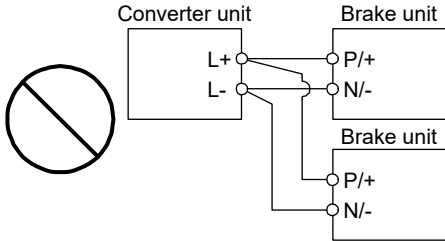
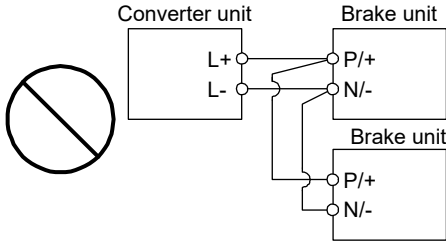
POINT	
<ul style="list-style-type: none"> ● To use brake units with a parallel connection, use two sets of FR-BU2-(H) brake unit. Combination with other brake unit results in alarm occurrence or malfunction. ● Always connect the terminals for master/slave (MSG to MSG, SD to SD) between the two brake units. ● Do not connect as follows. 	
	
Connecting two cables to L+ and L- terminals	Passing wiring

Part 5: Review on Replacement of MR-J3-DU_ with MR-J4-DU_

(a) When magnetic contactor drive output is enabled

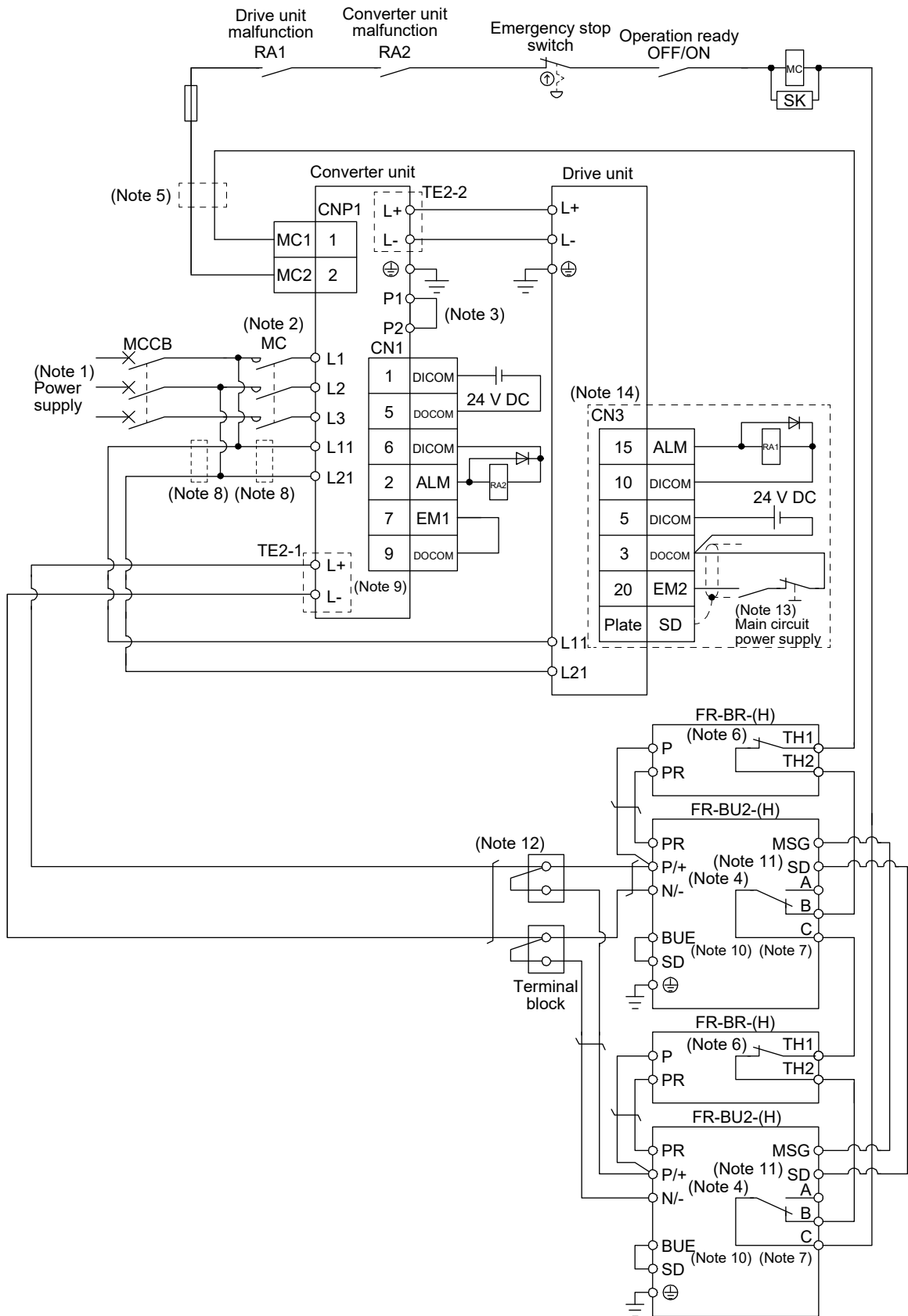

Part 5: Review on Replacement of MR-J3-DU_ with MR-J4-DU_

- Note
1. For the power supply specifications, refer to "Part 8: Common Reference Material".
 2. Use a magnetic contactor with an operation delay time (interval between current being applied to the coil until closure of contacts) of 80 ms or less. Depending on the main circuit voltage and operation pattern, bus voltage decreases, and that may cause the forced stop deceleration to shift to the dynamic brake deceleration. When dynamic brake deceleration is not required, slow the time to turn off the magnetic contactor.
 3. P1 and P2 are connected by default. When using the power factor improving DC reactor, connect P1 and P2 after removing the short bar across them. Refer to "Part 10: Chapter 7" for details.
 4. Connect P/+ and N/- terminals of the brake unit to a correct destination. Incorrect connection destination results in the converter unit and brake unit malfunction.
 5. For 400 V class, a step-down transformer is required.
 6. Contact rating: 1b contact, 110 V AC, 5 A/220 V AC, 3 A
Normal condition: TH1-TH2 is conducting. Abnormal condition: TH1-TH2 is not conducting.
 7. Contact rating: 230 V AC, 0.3 A/30 V DC, 0.3 A
Normal condition: B-C is conducting./A-C is not conducting. Abnormal condition: B-C is not conducting./A-C is conducting.
 8. Install an overcurrent protection device (molded-case circuit breaker, fuse, or others) to protect the branch circuit. (Refer to section 7.3.)
 9. Do not connect more than one cable to each L+ and L- terminals of TE2-1 of the converter unit.
 10. Always connect BUE and SD terminals. (factory-wired)
 11. Connect MSG and SD terminals of the brake unit to a correct destination. Incorrect connection destination results in the converter unit and brake unit malfunction.
 12. For connecting L+ and L- terminals of TE2-1 of the converter unit to the terminal block, use the cable indicated in (4) in this section.
 13. Configure a circuit to turn off EM2 in the drive unit when the main circuit power is turned off to prevent an unexpected restart of the drive unit.
 14. The wiring is for MR-J4-DU_B_(-RJ). The connection for the interface of MR-J4-DU_(-RJ) is the same as in the case of MR-J4_(-RJ). Refer to each servo amplifier instruction manual.

Part 5: Review on Replacement of MR-J3-DU_ with MR-J4-DU_

(b) When magnetic contactor drive output is disabled

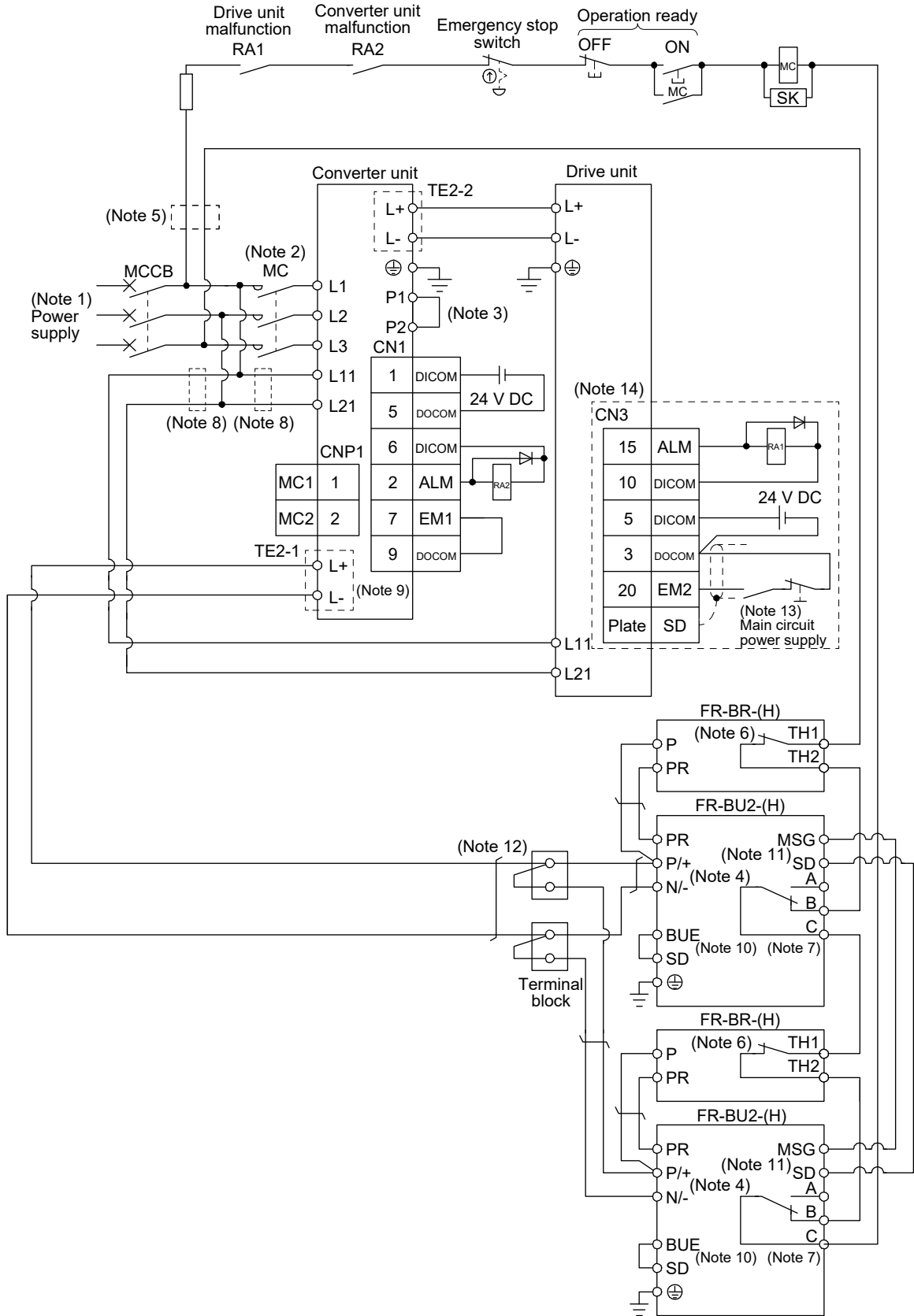

Part 5: Review on Replacement of MR-J3-DU_ with MR-J4-DU_

- Note
1. For the power supply specifications, refer to "Part 8: Common Reference Material".
 2. Use a magnetic contactor with an operation delay time (interval between current being applied to the coil until closure of contacts) of 80 ms or less. Depending on the main circuit voltage and operation pattern, bus voltage decreases, and that may cause the forced stop deceleration to shift to the dynamic brake deceleration. When dynamic brake deceleration is not required, slow the time to turn off the magnetic contactor.
 3. P1 and P2 are connected by default. When using the power factor improving DC reactor, connect P1 and P2 after removing the short bar across them. Refer to "Part 10: Chapter 7" for details.
 4. Connect P/+ and N/- terminals of the brake unit to a correct destination. Incorrect connection destination results in the converter unit and brake unit malfunction.
 5. For 400 V class, a step-down transformer is required.
 6. Contact rating: 1b contact, 110 V AC, 5 A/220 V AC, 3 A
Normal condition: TH1-TH2 is conducting. Abnormal condition: TH1-TH2 is not conducting.
 7. Contact rating: 230 V AC, 0.3 A/30 V DC, 0.3 A
Normal condition: B-C is conducting./A-C is not conducting. Abnormal condition: B-C is not conducting./A-C is conducting.
 8. Install an overcurrent protection device (molded-case circuit breaker, fuse, or others) to protect the branch circuit. (Refer to section 7.3.)
 9. Do not connect more than one cable to each L+ and L- terminals of TE2-1 of the converter unit.
 10. Always connect BUE and SD terminals. (factory-wired)
 11. Connect MSG and SD terminals of the brake unit to a correct destination. Incorrect connection destination results in the converter unit and brake unit malfunction.
 12. For connecting L+ and L- terminals of TE2-1 of the converter unit to the terminal block, use the cable indicated in (4) in this section.
 13. Configure a circuit to turn off EM2 in the drive unit when the main circuit power is turned off to prevent an unexpected restart of the drive unit.
 14. The wiring is for MR-J4-DU_B_(-RJ). The connection for the interface of MR-J4-DU_(-RJ) is the same as in the case of MR-J4_(-RJ). Refer to each servo amplifier instruction manual.

Part 5: Review on Replacement of MR-J3-DU_ with MR-J4-DU_

- (2) Combination with MT-BR5-(H) resistor unit
 - (a) When connecting a brake unit to a converter unit
 - 1) When magnetic contactor drive output is enabled

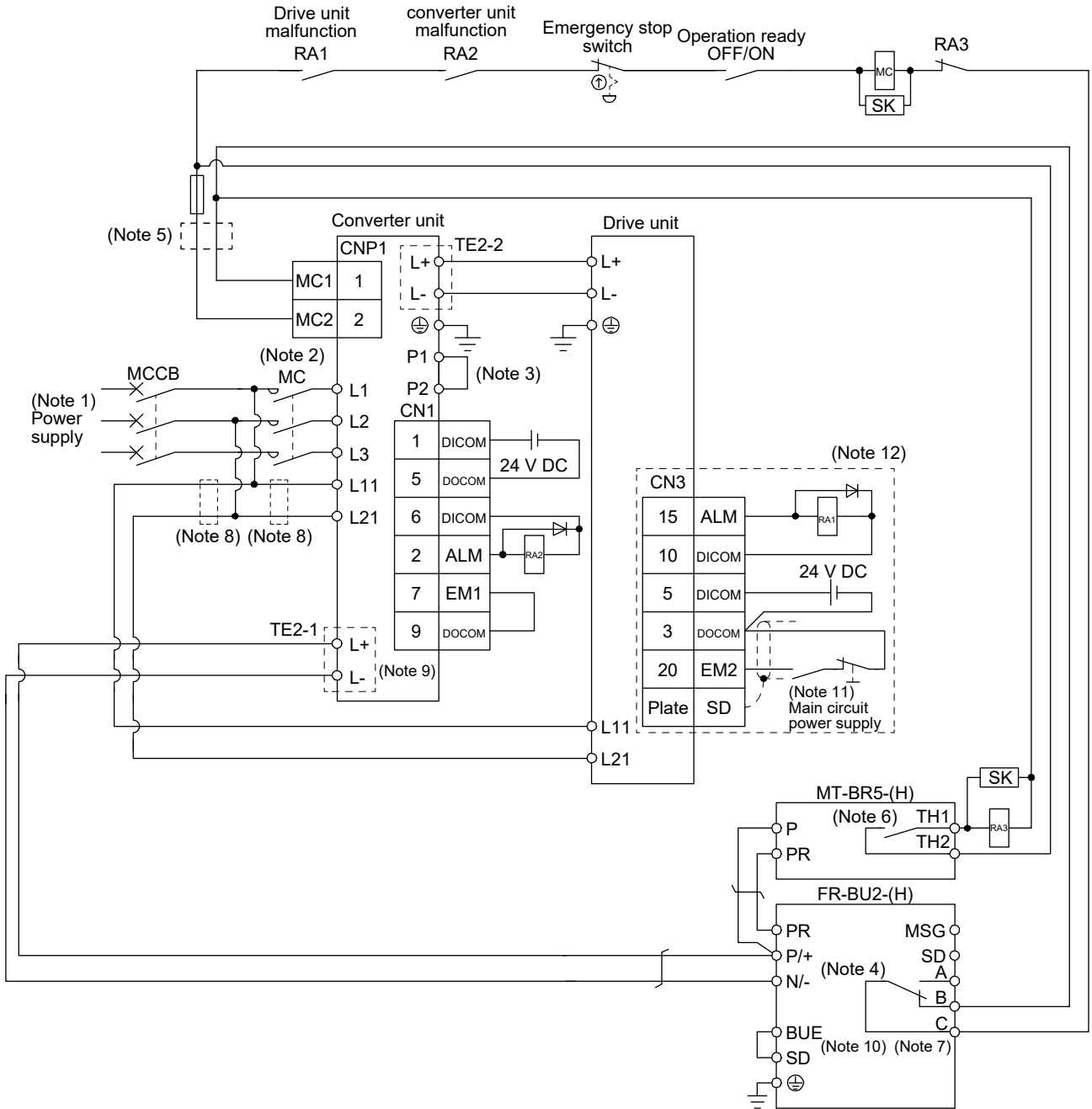

Part 5: Review on Replacement of MR-J3-DU_ with MR-J4-DU_

- Note
1. For the power supply specifications, refer to "Part 8: Common Reference Material".
 2. Use a magnetic contactor with an operation delay time (interval between current being applied to the coil until closure of contacts) of 80 ms or less. Depending on the main circuit voltage and operation pattern, bus voltage decreases, and that may cause the forced stop deceleration to shift to the dynamic brake deceleration. When dynamic brake deceleration is not required, slow the time to turn off the magnetic contactor.
 3. P1 and P2 are connected by default. When using the power factor improving DC reactor, connect P1 and P2 after removing the short bar across them. Refer to "Part 10: Chapter 7" for details.
 4. Connect P/+ and N/- terminals of the brake unit to a correct destination. Incorrect connection destination results in the converter unit and brake unit malfunction.
 5. For 400 V class, a step-down transformer is required.
 6. Contact rating: 1a contact, 110 V AC, 5 A/220 V AC, 3 A
Normal condition: TH1-TH2 is not conducting. Abnormal condition: TH1-TH2 is conducting.
 7. Contact rating: 230 V AC, 0.3 A/30 V DC, 0.3 A
Normal condition: B-C is conducting./A-C is not conducting. Abnormal condition: B-C is not conducting./A-C is conducting.
 8. Install an overcurrent protection device (molded-case circuit breaker, fuse, or others) to protect the branch circuit. (Refer to section 7.3.)
 9. Do not connect more than one cable to each L+ and L- terminals of TE2-1 of the converter unit.
 10. Always connect BUE and SD terminals. (factory-wired)
 11. Configure a circuit to turn off EM2 in the drive unit when the main circuit power is turned off to prevent an unexpected restart of the drive unit.
 12. The wiring is for MR-J4-DU_B_(-RJ). The connection for the interface of MR-J4-DU_(-RJ) is the same as in the case of MR-J4_(-RJ). Refer to each servo amplifier instruction manual.

Part 5: Review on Replacement of MR-J3-DU_ with MR-J4-DU_

2) When magnetic contactor drive output is disabled

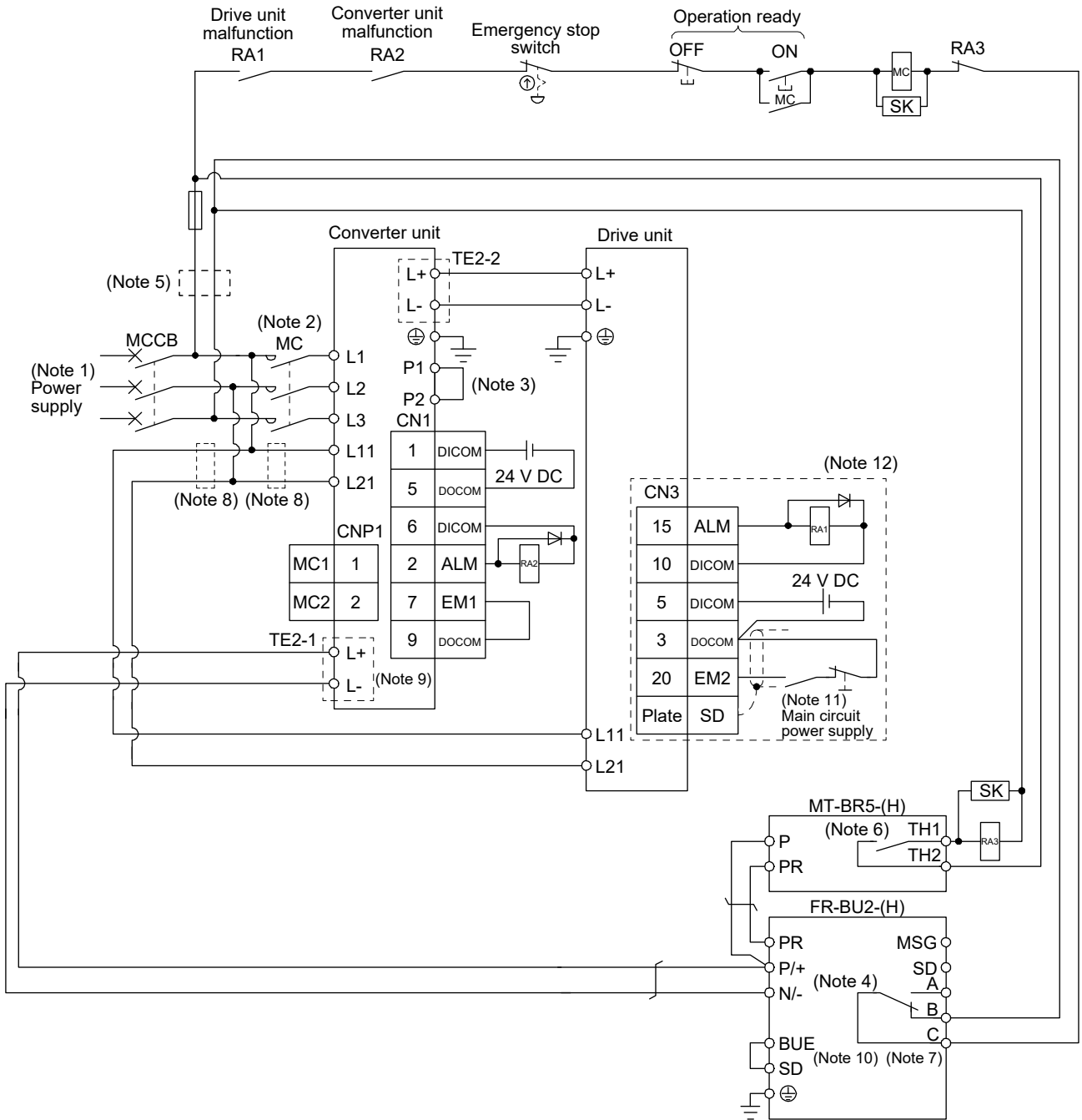

Part 5: Review on Replacement of MR-J3-DU_ with MR-J4-DU_

- Note
1. For the power supply specifications, refer to "Part 8: Common Reference Material".
 2. Use a magnetic contactor with an operation delay time (interval between current being applied to the coil until closure of contacts) of 80 ms or less. Depending on the main circuit voltage and operation pattern, bus voltage decreases, and that may cause the forced stop deceleration to shift to the dynamic brake deceleration. When dynamic brake deceleration is not required, slow the time to turn off the magnetic contactor.
 3. P1 and P2 are connected by default. When using the power factor improving DC reactor, connect P1 and P2 after removing the short bar across them. Refer to "Part 10: Chapter 7" for details.
 4. Connect P/+ and N/- terminals of the brake unit to a correct destination. Incorrect connection destination results in the converter unit and brake unit malfunction.
 5. For 400 V class, a step-down transformer is required.
 6. Contact rating: 1a contact, 110 V AC, 5 A/220 V AC, 3 A
Normal condition: TH1-TH2 is not conducting. Abnormal condition: TH1-TH2 is conducting.
 7. Contact rating: 230 V AC, 0.3 A/30 V DC, 0.3 A
Normal condition: B-C is conducting./A-C is not conducting. Abnormal condition: B-C is not conducting./A-C is conducting.
 8. Install an overcurrent protection device (molded-case circuit breaker, fuse, or others) to protect the branch circuit. (Refer to section 7.3.)
 9. Do not connect more than one cable to each L+ and L- terminals of TE2-1 of the converter unit.
 10. Always connect BUE and SD terminals. (factory-wired)
 11. Configure a circuit to turn off EM2 in the drive unit when the main circuit power is turned off to prevent an unexpected restart of the drive unit.
 12. The wiring is for MR-J4-DU_B_(-RJ). The connection for the interface of MR-J4-DU_(-RJ) is the same as in the case of MR-J4_(-RJ). Refer to each servo amplifier instruction manual.

Part 5: Review on Replacement of MR-J3-DU_ with MR-J4-DU_

(b) When connecting two brake units to a converter unit

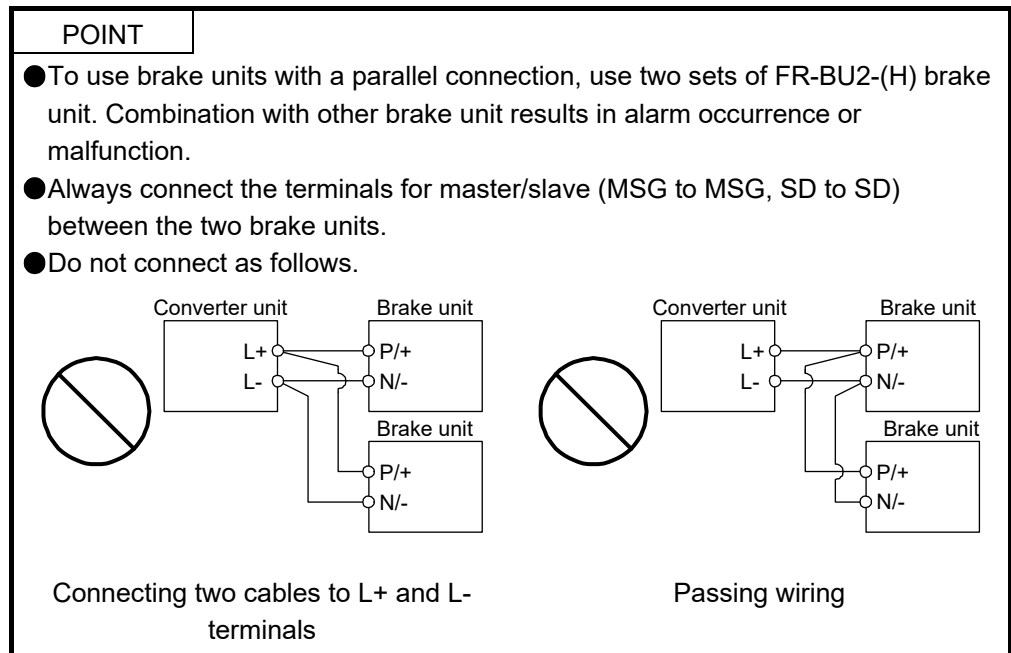

Part 5: Review on Replacement of MR-J3-DU_ with MR-J4-DU_

1) When magnetic contactor drive output is enabled

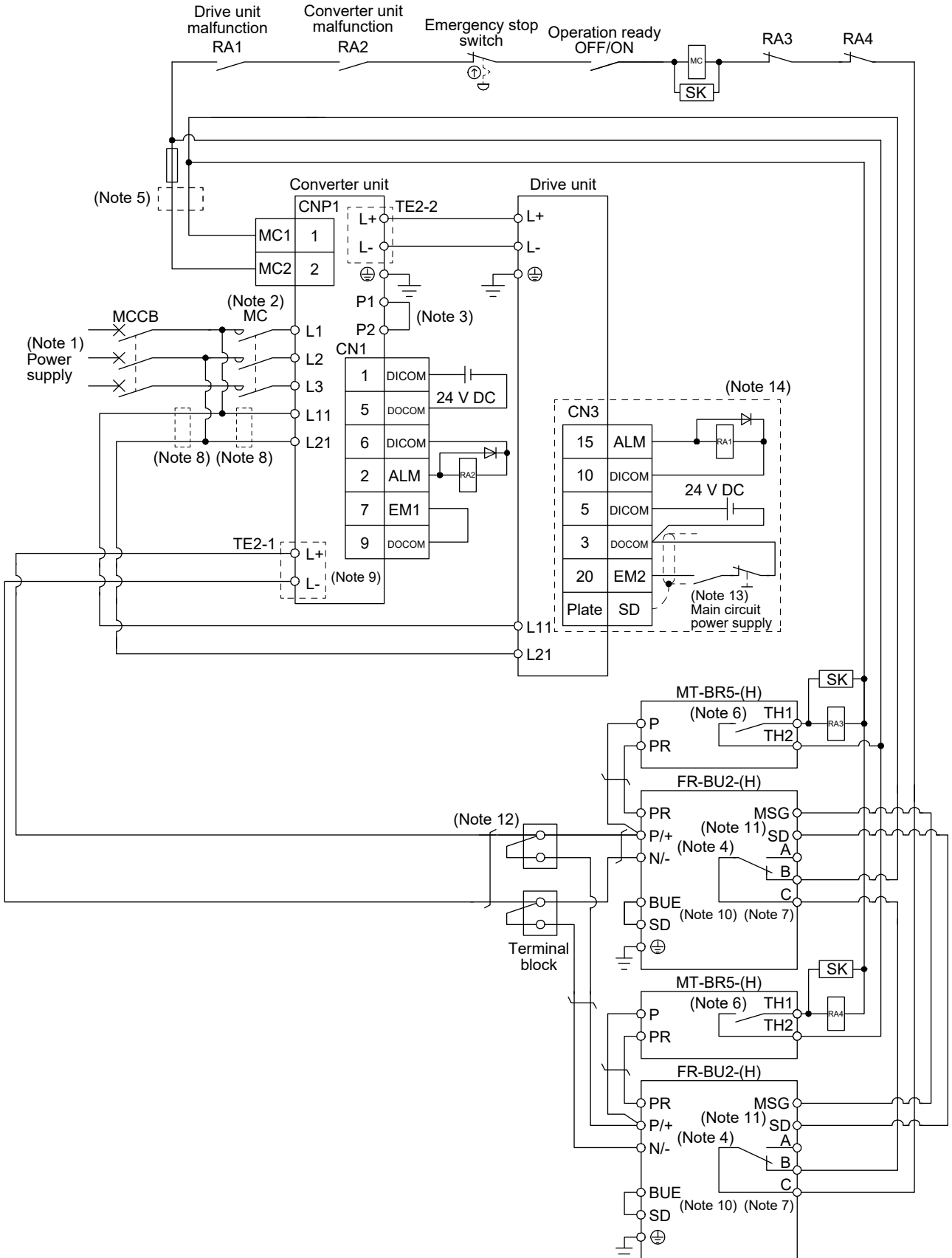

Part 5: Review on Replacement of MR-J3-DU_ with MR-J4-DU_

- Note
1. For the power supply specifications, refer to "Part 8: Common Reference Material".
 2. Use a magnetic contactor with an operation delay time (interval between current being applied to the coil until closure of contacts) of 80 ms or less. Depending on the main circuit voltage and operation pattern, bus voltage decreases, and that may cause the forced stop deceleration to shift to the dynamic brake deceleration. When dynamic brake deceleration is not required, slow the time to turn off the magnetic contactor.
 3. P1 and P2 are connected by default. When using the power factor improving DC reactor, connect P1 and P2 after removing the short bar across them. Refer to "Part 10: Chapter 7" for details.
 4. Connect P/+ and N/- terminals of the brake unit to a correct destination. Incorrect connection destination results in the converter unit and brake unit malfunction.
 5. For 400 V class, a step-down transformer is required.
 6. Contact rating: 1a contact, 110 V AC, 5 A/220 V AC, 3 A
Normal condition: TH1-TH2 is not conducting. Abnormal condition: TH1-TH2 is conducting.
 7. Contact rating: 230 V AC, 0.3 A/30 V DC, 0.3 A
Normal condition: B-C is conducting./A-C is not conducting. Abnormal condition: B-C is not conducting./A-C is conducting.
 8. Install an overcurrent protection device (molded-case circuit breaker, fuse, or others) to protect the branch circuit. (Refer to section 7.3.)
 9. Do not connect more than one cable to each L+ and L- terminals of TE2-1 of the converter unit.
 10. Always connect BUE and SD terminals. (factory-wired)
 11. Connect MSG and SD terminals of the brake unit to a correct destination. Incorrect connection destination results in the converter unit and brake unit malfunction.
 12. For connecting L+ and L- terminals of the converter unit to the terminal block, use the cable indicated in (4) in this section.
 13. Configure a circuit to turn off EM2 in the drive unit when the main circuit power is turned off to prevent an unexpected restart of the drive unit.
 14. The wiring is for MR-J4-DU_B_(-RJ). The connection for the interface of MR-J4-DU_(-RJ) is the same as in the case of MR-J4_(-RJ). Refer to each servo amplifier instruction manual.

Part 5: Review on Replacement of MR-J3-DU_ with MR-J4-DU_

2) When magnetic contactor drive output is disabled

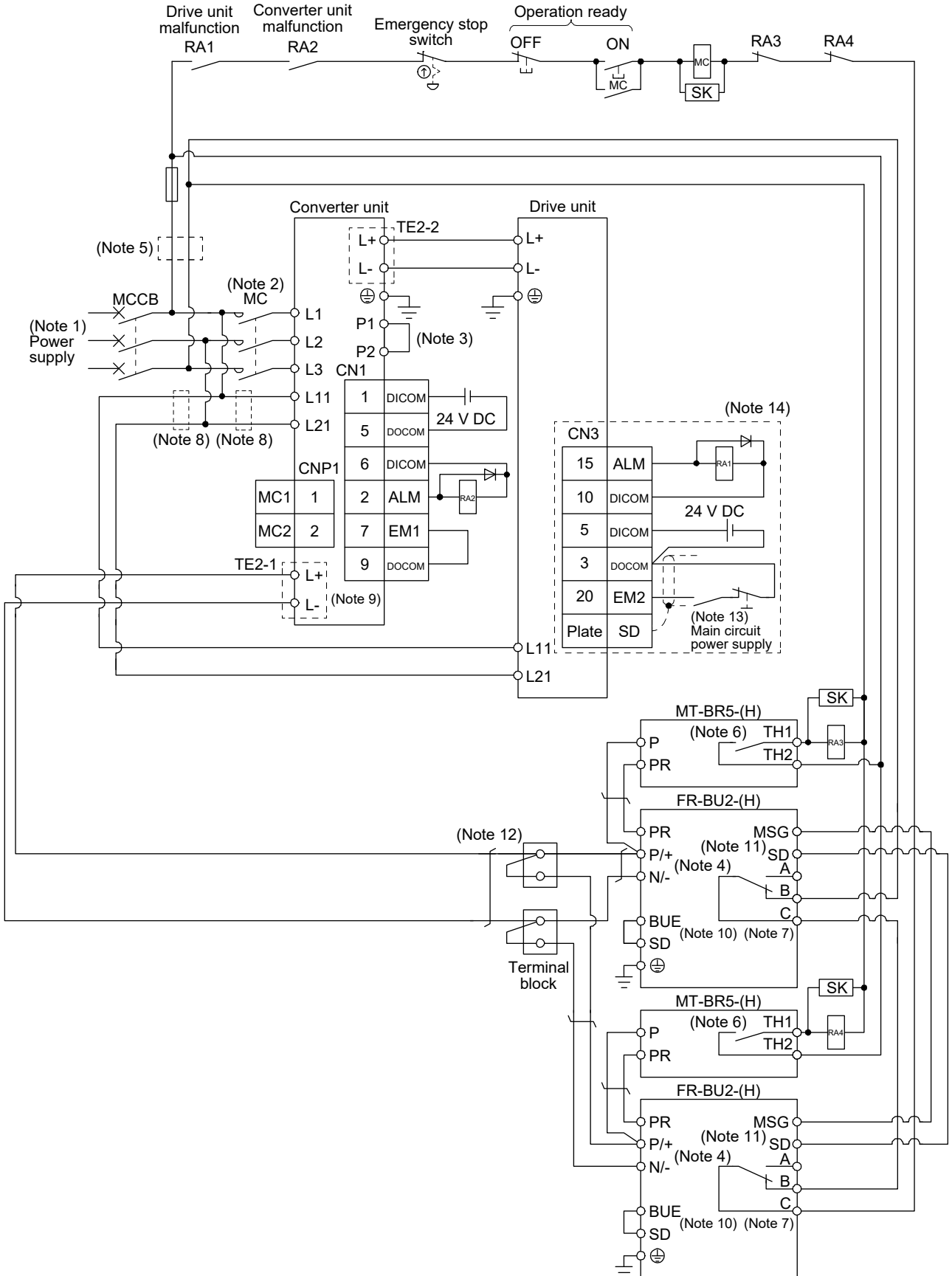

Part 5: Review on Replacement of MR-J3-DU_ with MR-J4-DU_

- Note
1. For the power supply specifications, refer to "Part 8: Common Reference Material".
 2. Use a magnetic contactor with an operation delay time (interval between current being applied to the coil until closure of contacts) of 80 ms or less. Depending on the main circuit voltage and operation pattern, bus voltage decreases, and that may cause the forced stop deceleration to shift to the dynamic brake deceleration. When dynamic brake deceleration is not required, slow the time to turn off the magnetic contactor.
 3. P1 and P2 are connected by default. When using the power factor improving DC reactor, connect P1 and P2 after removing the short bar across them. Refer to "Part 10: Chapter 7" for details.
 4. Connect P/+ and N/- terminals of the brake unit to a correct destination. Incorrect connection destination results in the converter unit and brake unit malfunction.
 5. For 400 V class, a step-down transformer is required.
 6. Contact rating: 1a contact, 110 V AC, 5 A/220 V AC, 3 A
Normal condition: TH1-TH2 is not conducting. Abnormal condition: TH1-TH2 is conducting.
 7. Contact rating: 230 V AC, 0.3 A/30 V DC, 0.3 A
Normal condition: B-C is conducting./A-C is not conducting. Abnormal condition: B-C is not conducting./A-C is conducting.
 8. Install an overcurrent protection device (molded-case circuit breaker, fuse, or others) to protect the branch circuit. (Refer to section 7.3.)
 9. Do not connect more than one cable to each L+ and L- terminals of TE2-1 of the converter unit.
 10. Always connect BUE and SD terminals. (factory-wired)
 11. Connect MSG and SD terminals of the brake unit to a correct destination. Incorrect connection destination results in the converter unit and brake unit malfunction.
 12. For connecting L+ and L- terminals of the converter unit to the terminal block, use the cable indicated in (4) in this section.
 13. Configure a circuit to turn off EM2 in the drive unit when the main circuit power is turned off to prevent an unexpected restart of the drive unit.
 14. The wiring is for MR-J4-DU_B_(-RJ). The connection for the interface of MR-J4-DU_(-RJ) is the same as in the case of MR-J4_(-RJ). Refer to each servo amplifier instruction manual.

Part 5: Review on Replacement of MR-J3-DU_ with MR-J4-DU_

(3) Connection instructions

Keep the wires between the converter unit and the brake unit, and between the resistor unit and the brake unit as short as possible. For wires longer than 5 m, twist the wires five times or more per meter. The wires should not exceed 10 m even when the wires are twisted. If wires exceeding 5 m without twisted or exceeding 10 m with or without twisted are used, the brake unit may malfunction.

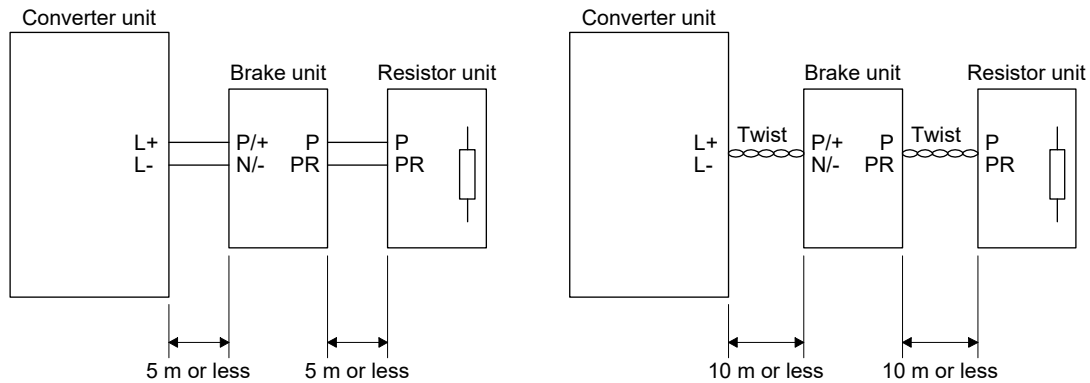

(4) Wires

(a) Wires for the brake unit

For the brake unit, HIV wire (600 V Grade heat-resistant polyvinyl chloride insulated wire) is recommended.

1) Main circuit terminal

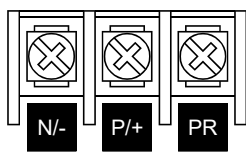

Terminal block

Brake unit		Main circuit terminal screw size	Crimp terminal N/-, P/+, PR, ⊕	Tightening torque [N•m]	Wire size	
					N/-, P/+, PR, ⊕	
					HIV wire [mm ²]	AWG
200 V class	FR-BU2-55K	M6	14-6	4.4	14	6
400 V class	FR-BU2-H55K	M5	5.5-5	2.5	5.5	10
	FR-BU2-H75K	M6	14-6	4.4	14	6

2) Control circuit terminal

POINT
<ul style="list-style-type: none"> ● Under tightening can cause a cable disconnection or malfunction. Over tightening can cause a short circuit or malfunction due to damage to the screw or the brake unit.



Terminal block

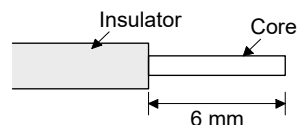

Wire the stripped cable after twisting to prevent the cable from becoming loose. In addition, do not solder it.

Screw size: M3

Tightening torque: 0.5 N•m to 0.6 N•m

Wire size: 0.3 mm² to 0.75 mm²

Screw driver: Small flat-blade screwdriver

(Tip thickness: 0.4 mm/Tip width 2.5 mm)

Part 5: Review on Replacement of MR-J3-DU_ with MR-J4-DU_

- (b) Cables for connecting the converter unit and a distribution terminal block when connecting two sets of the brake unit

Brake unit		Wire size	
		HIV wire [mm ²]	AWG
200 V class	FR-BU2-55K	38	2
400 V class	FR-BU2-H55K	14	6
	FR-BU2-H75K	38	2

- (5) Crimp terminals for L+ and L- terminals of TE2-1 of converter unit

- (a) Recommended crimp terminals

POINT
<p>● Some crimp terminals may not be mounted depending on their sizes. Make sure to use the recommended ones or equivalent ones.</p>

Converter unit		Brake unit	Number of connected units	Crimp terminal (Manufacturer)	Applicable tool (Note 1)
200 V class	MR-CR55K	FR-BU2-55K	2	38-S6 (JST (J.S.T. Mfg. Co., Ltd.)) (Note 2) R38-6S (NICHIFU (NICHIFU CO., LTD.)) (Note 2)	a
400 V class	MR-CR55K4	FR-BU2-H55K	2	FVD14-6 (JST (J.S.T. Mfg. Co., Ltd.))	b
		FR-BU2-H75K	2	38-S6 (JST (J.S.T. Mfg. Co., Ltd.)) (Note 2) R38-6S (NICHIFU (NICHIFU CO., LTD.)) (Note 2)	a

- Note 1. Symbols in the applicable tool field indicate applicable tools in (5) (b) in this section.
2. Coat the crimping part with an insulation tube.

- (b) Applicable tool

Symbol	Converter unit-side crimp terminal				
	Crimp terminal	Applicable tool			Manufacturer
		Body	Head	Dice	
a	38-S6	YPT-60-21	YET-60-1	TD-124	JST (J.S.T. Mfg. Co., Ltd.)
		YF-1 E-4		TD-112	
a	R38-6S	NOP60 NOM60			NICHIFU (NICHIFU CO., LTD.)
b	FDV14-6	YF-1 E-4	YNE-38	DH-112 DH-122	JST (J.S.T. Mfg. Co., Ltd.)

Part 5: Review on Replacement of MR-J3-DU_ with MR-J4-DU_

7.4.4 Dimensions

- (1) FR-BU2-(H) brake unit
FR-BU2-55K/FR-BU2-H55K/FR-BU2-H75K

[Unit: mm]

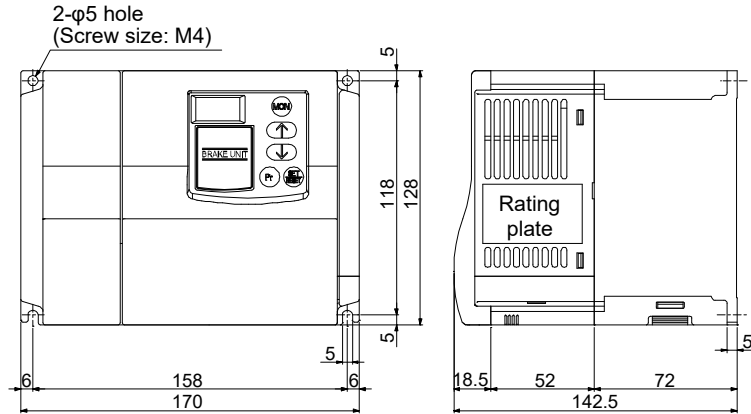

- (2) FR-BR-(H) resistor unit

[Unit: mm]

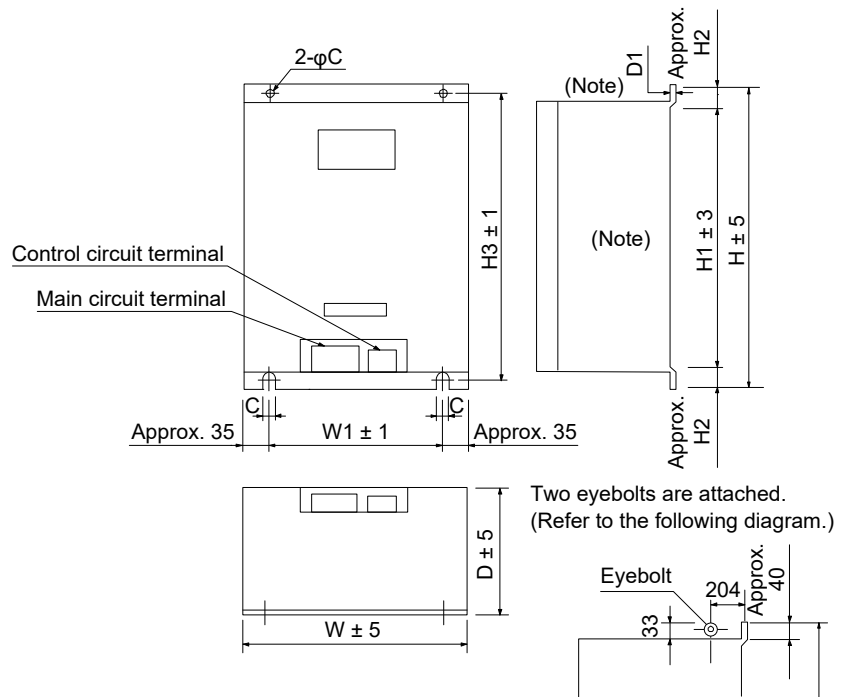

Note. Ventilation ports are provided on both sides and the top. The bottom is open.

Resistor unit		W	W1	H	H1	H2	H3	D	D1	C	Approximate mass [kg]
200 V class	FR-BR-55K	480	410	700	620	40	670	450	3.2	12	70
400 V class	FR-BR-H55K	480	410	700	620	20	670	450	3.2	12	70

Part 5: Review on Replacement of MR-J3-DU_ with MR-J4-DU_

(3) MT-BR5-(H) resistor unit

[Unit: mm]

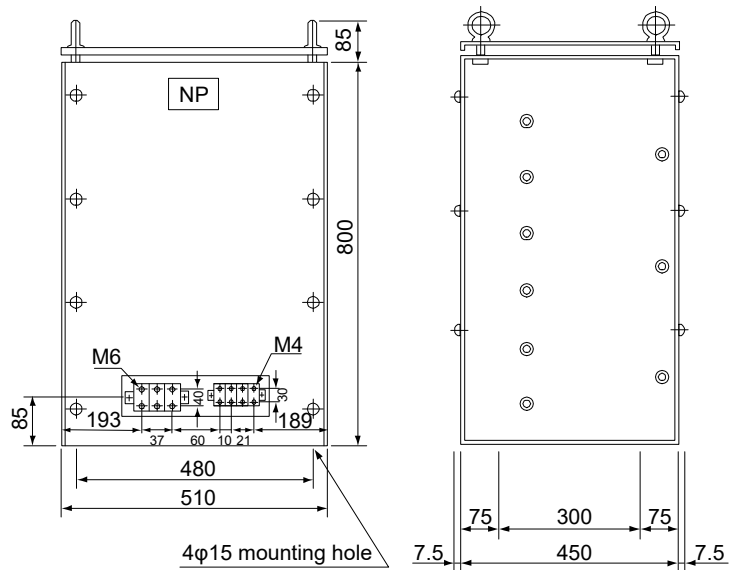

Resistor unit		Resistance	Approximate mass [kg]
200 V class	MT-BR5-55K	2.0 Ω	50
400 V class	MT-BR5-H75K	6.5 Ω	70

Part 5: Review on Replacement of MR-J3-DU_ with MR-J4-DU_

7.5 Regenerative option

	CAUTION	● Do not use the converter unit and drive unit with the regenerative options other than the combinations specified below. Otherwise, it may cause a fire.
---	----------------	---

7.5.1 Combination and regenerative power

(1) MR-J3 series

The regenerative power values in the table are the regenerative power of the resistor and are not the rated power.

Converter unit	Drive unit	Regenerative power [W]			
		MR-RB139 (1.3 Ω)	MR-RB137 Three MR-RB137 (1.3 Ω) in parallel (Note 1)	MR-RB136-4 (5 Ω)	MR-RB138-4 Three MR-RB138-4 (5 Ω) in parallel (Note 2)
MR-J3-CR55K	MR-J3-DU30K_	1300	3900	/	/
	MR-J3-DU37K_				
MR-J3-CR55K4	MR-J3-DU30K_4	/	/	1300	3900
	MR-J3-DU37K_4				
	MR-J3-DU45K_4				
	MR-J3-DU55K_4				

- Note 1. The composite resistor value of three options is 1.3 Ω. The resistor value of one option is 4 Ω.
 2. The composite resistor value of three options is 5 Ω. The resistor value of one option is 15 Ω.

(2) MR-J4 series

The regenerative power values in the table are the regenerative power of the resistor and are not the rated power.

The combinations of the regenerative option which differ from those for the J3 series are shown with the gray background.

Converter unit	Drive unit	Regenerative power [W]			
		MR-RB139 (1.3 Ω)	Three MR-RB137 (1.3 Ω) in parallel (Note 1)	MR-RB137-4 (4 Ω)	Three MR-RB13V-4 (4 Ω) in parallel (Note 2)
MR-CR55K	MR-J4-DU30K_	1300	3900	/	/
	MR-J4-DU37K_				
MR-CR55K4	MR-J4-DU30K_4	/	/	1300	3900
	MR-J4-DU37K_4				
	MR-J4-DU45K_4				
	MR-J4-DU55K_4				

- Note 1. The resultant resistance of three options is 1.3 Ω.
 2. The resultant resistance of three options is 4 Ω.

Part 5: Review on Replacement of MR-J3-DU_ with MR-J4-DU_

7.6 External dynamic brake

CAUTION

- Use an external dynamic brake for this drive unit. Failure to do so will cause an accident because the servo motor does not stop immediately but coasts at an alarm occurrence for which the servo motor does not decelerate to stop. Ensure the safety in the entire equipment. For alarms for which the servo motor does not decelerate to stop, refer to chapter 6.
- The external dynamic brake cannot be used for compliance with SEMI-F47 standard. Do not assign DB. Doing so will cause the drive unit to become servo-off when an instantaneous power failure occurs.

POINT

- For drive units, EM2 has the same function as EM1 in the torque control mode.
- Configure a sequence which switches off the magnetic contactor of the external dynamic brake after (or as soon as) SON (Servo-on) has been turned off at a power failure or a malfunction.
- For the external braking time taken when the dynamic brake is operated, refer to each servo amplifier instruction manual.
- The external dynamic brake is rated for a short duration. Do not use it very frequently.
- The specifications of the input power supply for external dynamic brake are the same as those of the converter unit control circuit power supply.
- When an alarm, [AL. E6 Servo forced stop warning], or [AL. E7 Controller forced stop warning] occurs, or the power is turned off, the external dynamic brake will operate. Do not use external dynamic brake to stop in a normal operation as it is the function to stop in emergency.
- For a machine operating at the recommended load to motor inertia ratio or less, the estimated number of usage times of the external dynamic brake is 1000 times while the machine decelerates from the rated speed to a stop once in 10 minutes.
- Be sure to enable EM1 (Forced stop 1) after servo motor stops when using EM1 frequently in other than emergency.

7.6.1 MR-J3 series

The dynamic brake is designed to bring the servo motor to a sudden stop when a power failure occurs or the protective circuit is activated. When using the external dynamic brake, assign the dynamic brake interlock (DB) to any of CN3-9, CN3-13, and CN3-15 pins in [Pr. PD07 to PD09].

Converter unit	Drive unit	Dynamic brake
MR-J3-CR55K	MR-J3-DU30K_	DBU-37K
	MR-J3-DU37K_	
MR-J3-CR55K4	MR-J3-DU30K_4	DBU-55K-4
	MR-J3-DU37K_4	
	MR-J3-DU45K_4	
	MR-J3-DU55K_4	

Part 5: Review on Replacement of MR-J3-DU_ with MR-J4-DU_

7.6.2 MR-J4 series

The external dynamic brake is designed to bring the servo motor to a sudden stop when a power failure occurs or the protective circuit is activated. For MR-J4-DU_A_ drive unit, assign DB to any of CN1-22 to CN1-25, CN1-49, CN1-13 and CN1-14 pins in [Pr. PD23] to [Pr. PD26], [Pr. PD28] and [Pr. PD47]. For MR-J4-DU_B_ drive unit, assign DB to any of CN3-9, CN3-13, and CN3-15 pins in [Pr. PD07] to [Pr. PD09].

Converter unit	Drive unit	External dynamic brake
MR-CR-55K	MR-J4-DU30K_	DBU-37K-R1
	MR-J4-DU37K_	
MR-CR55K4	MR-J4-DU30K_4	DBU-55K-4-R5
	MR-J4-DU37K_4	
	MR-J4-DU45K_4	
	MR-J4-DU55K_4	

Part 6

Review on Replacement of MR-J3-T (DIO command/ Serial communication operation) with MR-J4-A-RJ

Part 6: Review on Replacement of MR-J3-_T_(DIO command/ Serial communication operation) with MR-J4-_A_-RJ

POINT
<ul style="list-style-type: none">●MR-D01 may not be required depending on how MR-J3-_T_ has been used (DIO command/Serial communication operation) and how MR-J3-D01 has been used (number of point tables, device selection status of external input and output signals, and position command data input method). For details, refer to "Section 3.1 Function Comparison Table" and "Section 3.3 Comparison of Standard Connection Diagrams".●MR-J3-D01 and MR-D01 have the same functions and performance. MR-J3-D01 can be used with MR-J4-_A_-RJ.

1. SUMMARY

This document describes the changes that are applied to when replacing a system using the MR-J3-_T_(DIO command/Serial communication operation) with a system using the MR-J4-_A_-RJ.

2. CASE STUDY ON REPLACEMENT OF MR-J3-_T_(DIO command/Serial communication operation)

2.1 Review on Replacement Method

POINT
<p>●MR-J3-_T_(DIO command/Serial communication operation) cannot drive an HG motor. When the servo motor is replaced with HG motor, simultaneous replacement with MR-J4-_A_-RJ and an HG motor is necessary.</p>

(1) MR-J3-_T_ + MR-J3-D01 (DIO command)

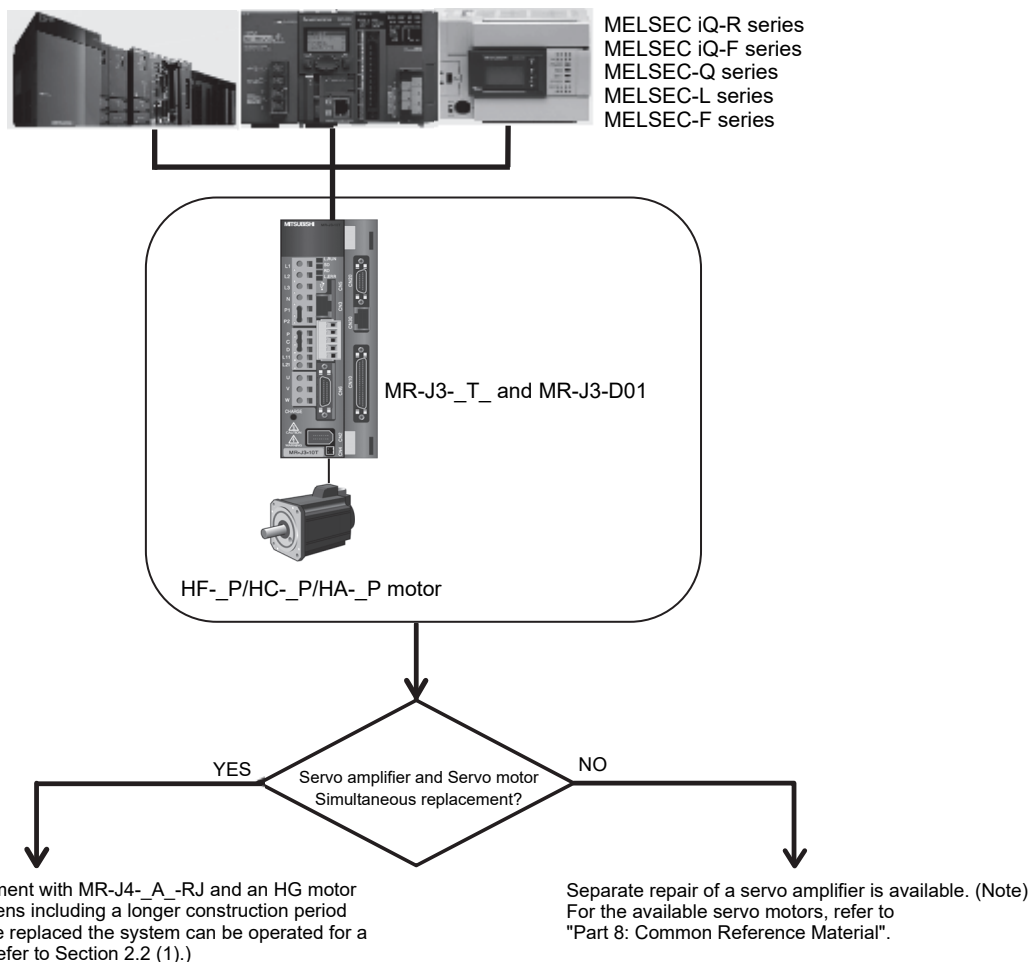

Note. Separate repair means replacement.

(2) MR-J3-_T_(Serial communication operation)

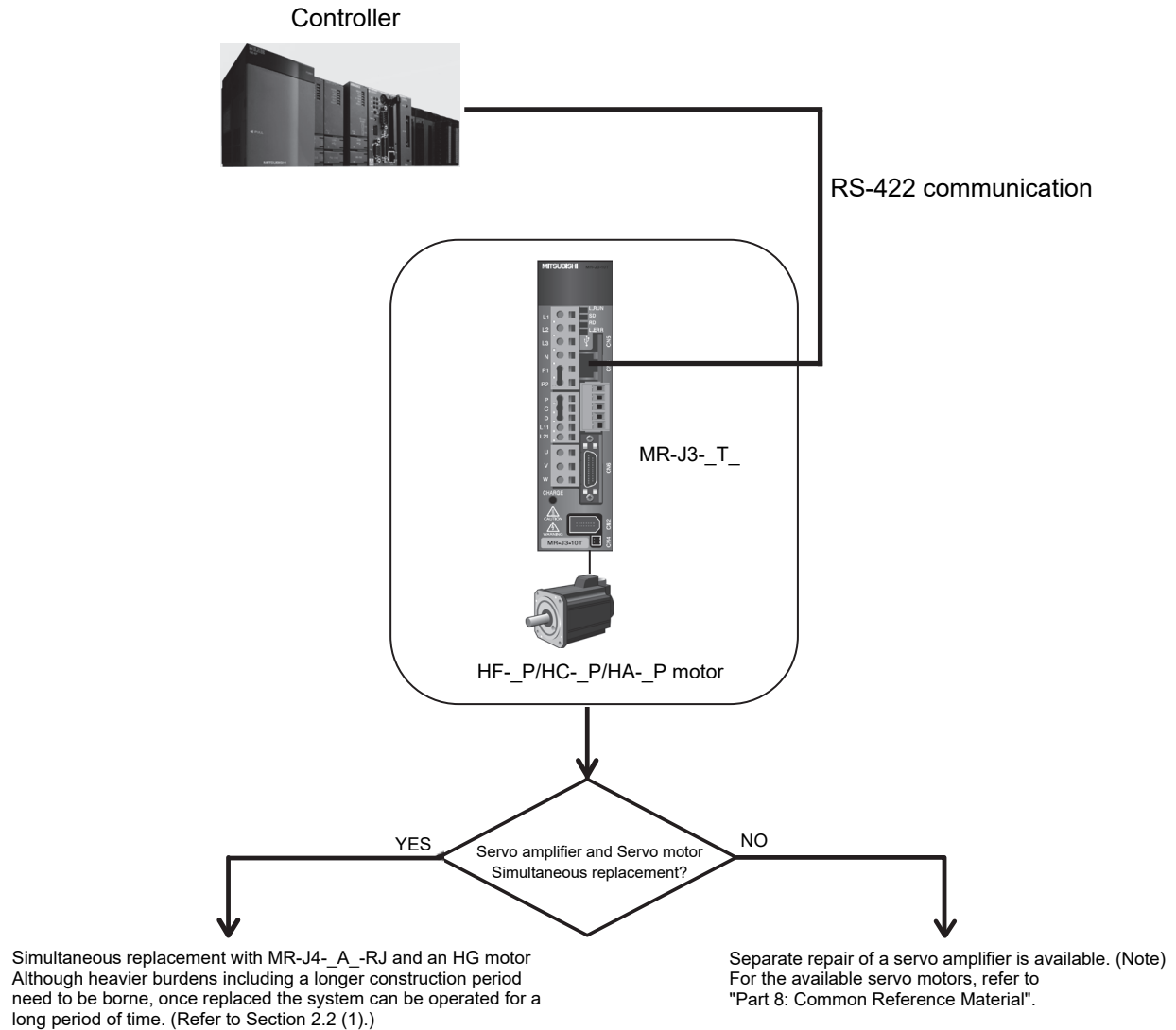

Note. Separate repair means replacement.

2.2 Replacement Method

(1) Simultaneous replacement with MR-J4-_A_ and an HG motor

The currently used connectors or cables need to be replaced. The parameters of the existing system can be transferred with the parameter converter function of MR Configurator2. (Refer to "Part 8: Common Reference Material".)

For DIO command

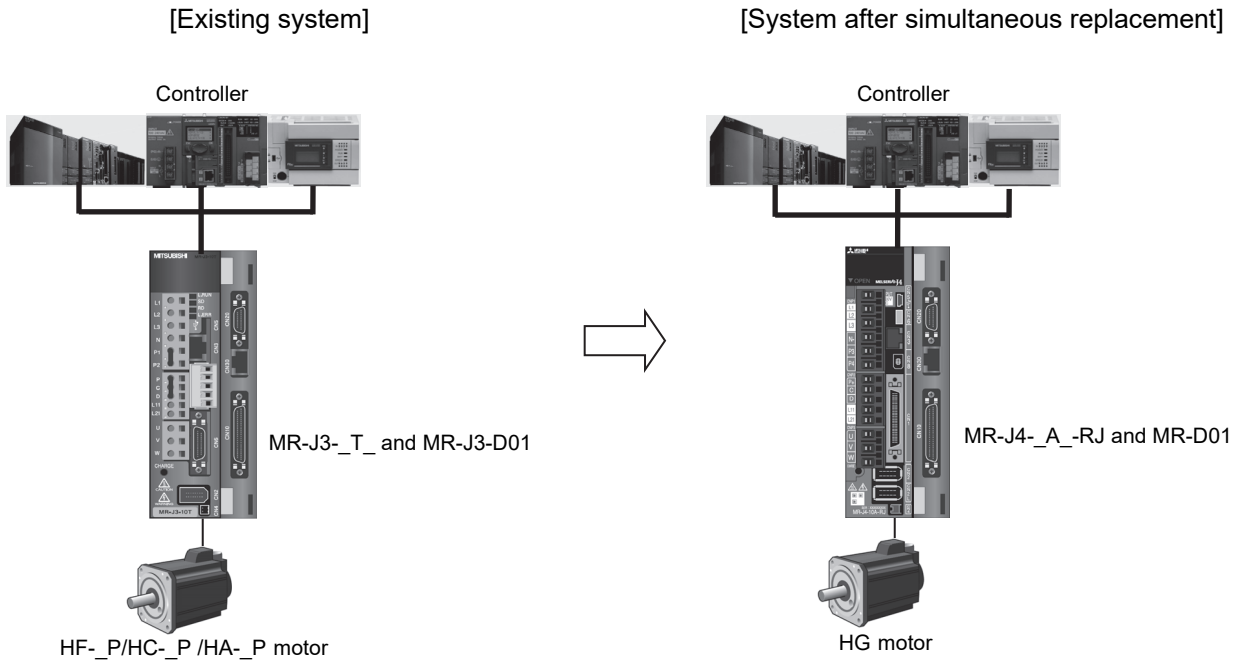

For Serial communication operation

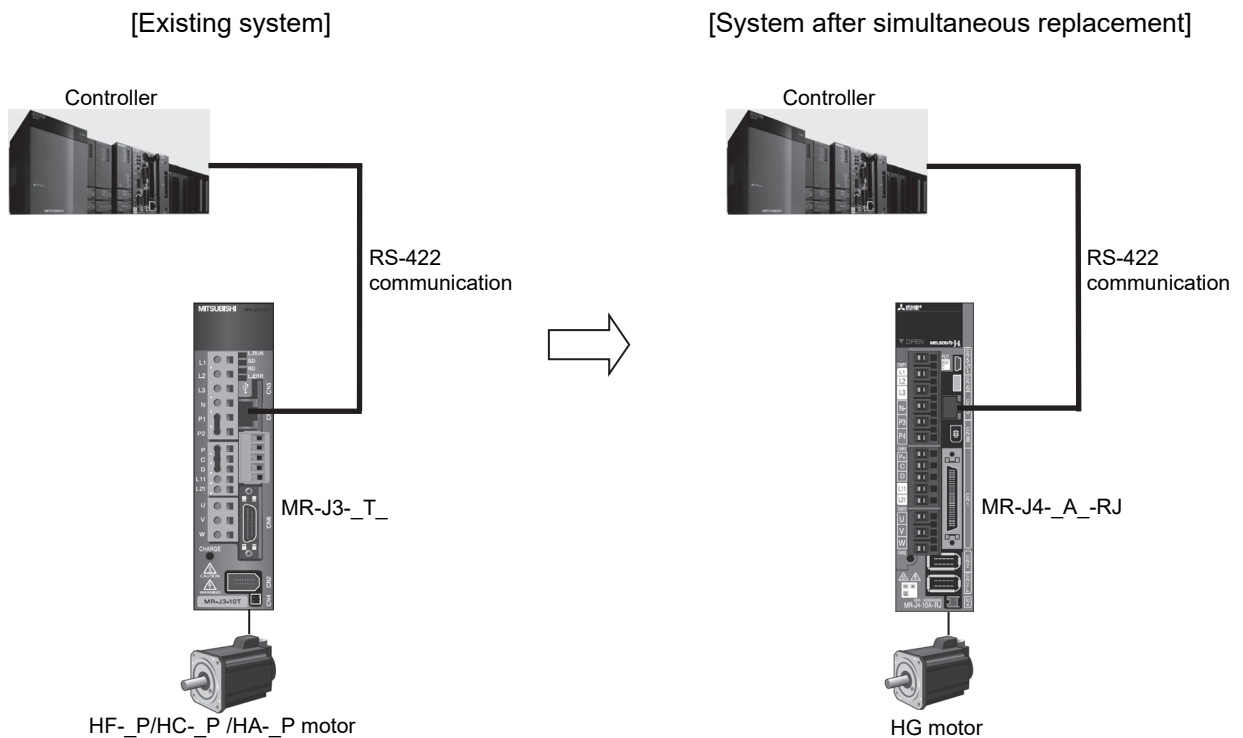

(2) Separate repair of servo amplifiers and servo motors

POINT			
<ul style="list-style-type: none"> ● MR-J3-_T_(DIO command/Serial communication operation) cannot drive an HG motor. When the servo motor is replaced with an HG motor, simultaneous replacement with MR-J4-_A_-RJ and an HG motor is unnecessary. ● If the existing system is any of the combinations in the following table, it is recommended to replace both the servo amplifier and servo motor with an MR-J4-_A_-RJ and HG motor at the same time. When an HG motor is adopted, the capacity of the servo amplifier needs to be changed. (Consider replacement, referring to "torque characteristics" described in "Part 9: Replacement of Motor".) ● The low inertia "HG-JR motor" is recommended for the replacement of "HC-LP motor". To use a servo motor other than the motors listed in following table, check the compatibility with the equipment because the motor inertia, etc. is different. 			
Existing device models		Replacement models for simultaneous replacement (example)	
Servo motor	Servo amplifier	Servo motor	Servo amplifier
HC-RP103(B)G5 1/_	MR-J3-200T	HG-SR102(B)G5 1/_	MR-J4-100A-RJ
HC-RP203(B)G5 1/_	MR-J3-350T	HG-SR202(B)G5 1/_	MR-J4-200A-RJ
HC-RP353(B)G5 1/_	MR-J3-500T	HG-SR352(B)G5 1/_	MR-J4-350A-RJ
HC-RP103(B)G7 1/_	MR-J3-200T	HG-SR102(B)G7 1/_	MR-J4-100A-RJ
HC-RP203(B)G7 1/_	MR-J3-350T	HG-SR202(B)G7 1/_	MR-J4-200A-RJ
HC-RP353(B)G7 1/_	MR-J3-500T	HG-SR352(B)G7 1/_	MR-J4-350A-RJ
HC-LP52(B)	MR-J3-60T	HG-JR73(B)	MR-J4-70A-RJ
HC-LP102(B)	MR-J3-100T	HG-JR153(B)	MR-J4-200A-RJ
HC-LP152(B)	MR-J3-200T	HG-JR353(B)	MR-J4-350A-RJ

(a) For replacement of servo amplifier

Allows the J3 series servo motors to drive in MR-J4-_A_-RJ. Refer to "Part 8: Common Reference Material" for target servo motors.

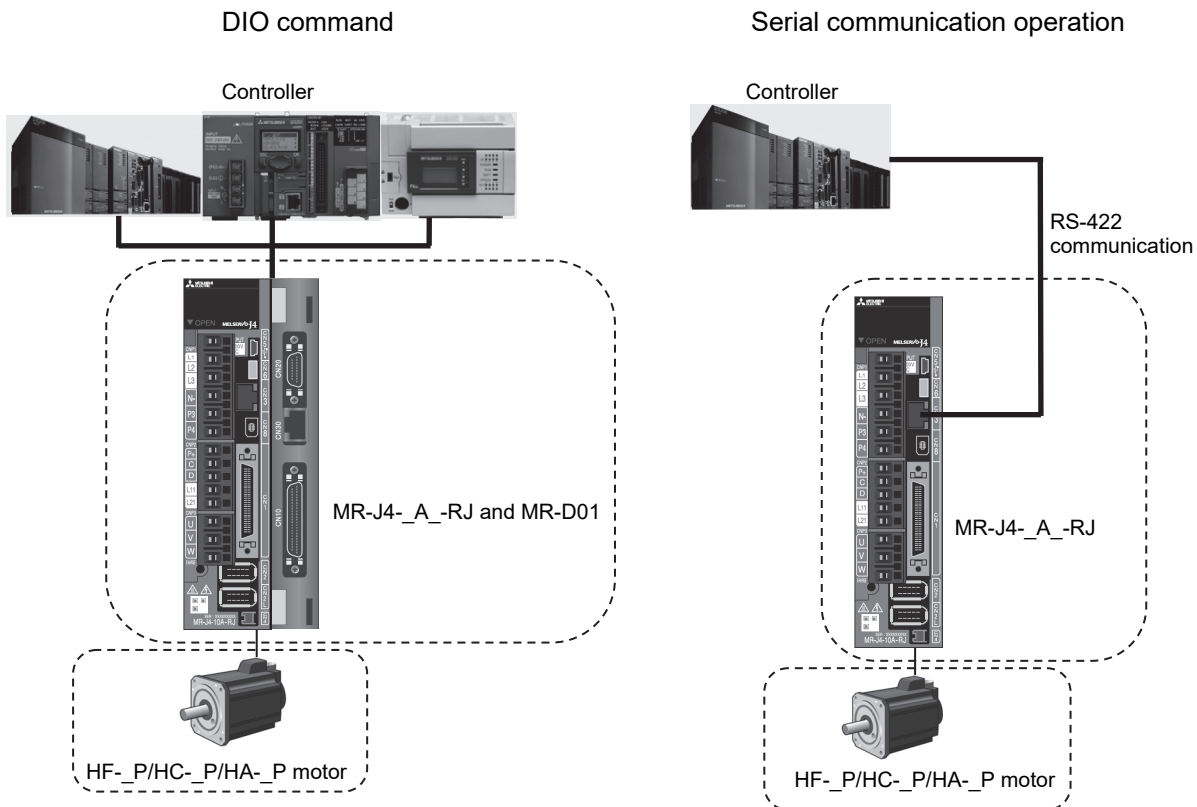

(b) For replacement of servo motor

MR-J3-_T_(DIO command/Serial communication operation) cannot drive an HG motor. When the servo motor is replaced with HG motor, simultaneous replacement with MR-J4-_A_-RJ and an HG motor is necessary.

3. DIFFERENCES BETWEEN MR-J3-_T_(DIO command/Serial communication operation) and MR-J4-_A_-RJ

3.1 Function Comparison Table

POINT
<ul style="list-style-type: none"> ● Functions with difference are shown with shading. ● When MR-J3-_T_ on which MR-J3-D01 has been mounted is replaced, MR-D01 may not be required to be mounted on MR-J4-_A_-RJ depending on the number of point tables, input device selection status, and position command data input method.

(1) 200 Vclass

Item	MR-J3-_T_ and MR-J3-D01	MR-J4-_A_-RJ and MR-D01
1	Capacity range	0.1 to 22 kW/200 V
2	Internal regenerative resistor	Built-in (0.2 to 7 kW) External (11 to 22 kW)
3	Dynamic brake	Built-in (0.1 to 7 kW) External (11 to 22 kW) Coasting distance may differ. (Note 1)
4	Control circuit power	1-phase 200 V AC to 230 V AC
5	Main circuit power	1-phase 200 V AC to 240 V AC (0.1 kW to 2 kW) (Note 2) 3-phase 200 V AC to 240 V AC (0.1 kW to 22 kW)
6	24 V DC power	External supply required
7	Auto Tuning	Real-time auto tuning: 32 steps Advanced gain search
8	Positioning mode	Real-time auto tuning: 40 steps One-touch tuning
9	Point table method	Point table method
	<p>Automatic operation mode</p> <ul style="list-style-type: none"> • Automatic operation with a point table • Automatic operation by BCD (3 digits 2) input with the MR-DS60 6-digit digital switch • Automatic operation by BCD (3 digits 2) input with the programmable controllers <p>Manual operation mode</p> <ul style="list-style-type: none"> • JOG operation • Manual pulse generator operation <p>Home position return mode</p> <ul style="list-style-type: none"> • Dog type home position return • Count type home position return • Data set type home position return • Stopper type home position return • Home position ignorance (servo-on position as home position) • Dog type rear end reference home position return • Count type front end reference home position return • Dog cradle type home position return • Dog type last Z-phase reference home position return • Dog type front end reference home position return type • Dogless Z-phase reference home position return type • Automatic retract function used for the home position return • Automatic positioning to home position function <p>Roll feed mode using the roll feed display function</p>	<p>Automatic operation mode</p> <ul style="list-style-type: none"> • Automatic operation with a point table • Automatic operation by BCD (3 digits 2) input with the MR-DS60 6-digit digital switch • Automatic operation by BCD (3 digits 2) input with the programmable controllers <p>Manual operation mode</p> <ul style="list-style-type: none"> • JOG operation • Manual pulse generator operation <p>Home position return mode</p> <ul style="list-style-type: none"> • Dog type home position return • Count type home position return • Data set type home position return • Stopper type home position return • Home position ignorance (servo-on position as home position) • Dog type rear end reference home position return • Count type front end reference home position return • Dog cradle type home position return • Dog type last Z-phase reference home position return • Dog type front end reference home position return type • Dogless Z-phase reference home position return type • Automatic retract function used for the home position return • Automatic positioning to home position function <p>Roll feed mode using the roll feed display function</p>

Item		MR-J3-_T_ and MR-J3-D01	MR-J4-_A_-RJ and MR-D01
10	Pulse input	Manual pulse generator (only for MR-HDP01) Open collector Pulse resolution: 1000 pulses/rev Maximum speed: Instantaneous maximum 600 r/min, normal 200 r/min	Manual pulse generator (only for MR-HDP01) Open collector Pulse resolution: 1000 pulses/rev Maximum speed: Instantaneous maximum 600 r/min, normal 200 r/min
11	Encoder pulse output	A/B/Z-phase pulse (differential line driver)	A/B/Z-phase pulse (differential line driver) Z-phase pulse (open-collector)
12	DIO interface	input/output: sink/source	input/output: sink/source
13	Analog input/output	[MR-J3-D01 only] (Input) 2ch Analog torque limit, Override (Output) 12-bit or equivalent × 2ch	[MR-J4-_A_-RJ] (Input) 2ch Analog torque limit, Override (Output) 10-bit or equivalent × 2ch [MR-D01] (Input) 2ch Analog torque limit, Override (Output) 12-bit or equivalent × 2ch [MR-J4-_A_-RJ and MR-D01] The analog inputs (analog torque limit and override) of MR-J4-_A_-RJ and MR-D01 are mutually exclusive functions. They cannot be used together.
14	Parameter setting method	Setup software (SETUP221E) MR Configurator2	MR Configurator2 Push button
15	Setup software communication function	USB	USB
16	Servo motor (Encoder resolution)	HF-_P series (18-bit ABS) HA-_P series (18-bit ABS)	HG series (22-bit ABS)
17	Motor maximum torque	HF-KP 350%	HG-KR 350%
		HF-MP 300%	HG-MR 300%
		HF-SP 300%	HG-SR 300%
		HF-JP 300%	HG-JR 300%
		HA-LP 250%	HG-JR 300%
18	LED display	7-segment 3-digit	7-segment 5-digit
19	Advanced vibration suppression control	Provided	Provided (Advanced vibration suppression control II)
20	Adaptive filter II	Provided	Provided
21	Notch filter	Provided (2 pcs)	Provided (5 pcs)
22	Tough drive	Unprovided	Provided
23	Drive recorder	Unprovided	Provided
24	Forced stop	EM1 (DB stop)	EM1 (DB stop)/EM2 (deceleration to a stop)

- Note
1. For the coasting distance, refer to "1.2.3 Dynamic brake: coasting distance" in "Part 7 Common Reference Material".
 2. If using a 1-phase 200 V AC to 240 V AC power supply with a 1 kW/2 kW servo amplifier, operate the servo amplifier at 75% or less of the effective load ratio.

(2) 400 V class

Item	MR-J3-_T_ and MR-J3-D01	MR-J4-_A_-RJ and MR-D01
1	Capacity range	0.6 to 22 kW/400 V
2	Internal regenerative resistor	Built-in (0.6 kW to 7 kW) External (11 kW to 22 kW)
3	Dynamic brake	Built-in (0.6 kW to 7 kW) External (11 kW to 22 kW) Coasting distance may differ. (Note)
4	Control circuit power	1-phase 380 V AC to 480 V AC
5	Main circuit power	3-phase 380 V AC to 480 V AC
6	24 V DC power	External supply required
7	Auto Tuning	Real-time auto tuning: 32 steps Advanced gain search
8	Positioning mode	Point table method
9	Point table method	Automatic operation mode <ul style="list-style-type: none"> • Automatic operation with a point table • Automatic operation by BCD (3 digits 2) input with the MR-DS60 6-digit digital switch • Automatic operation by BCD (3 digits 2) input with the programmable controllers Manual operation mode <ul style="list-style-type: none"> • JOG operation • Manual pulse generator operation Home position return mode <ul style="list-style-type: none"> • Dog type home position return • Count type home position return • Data set type home position return • Stopper type home position return • Home position ignorance (servo-on position as home position) • Dog type rear end reference home position return • Count type front end reference home position return • Dog cradle type home position return • Dog type last Z-phase reference home position return • Dog type front end reference home position return type • Dogless Z-phase reference home position return type • Automatic retract function used for the home position return • Automatic positioning to home position function Roll feed mode using the roll feed display function
10	Pulse input	Manual pulse generator (only for MR-HDP01) Open collector Pulse resolution: 1000 pulses/rev Maximum speed: Instantaneous maximum 600 r/min, normal 200 r/min
11	Encoder pulse output	A/B/Z-phase pulse (differential line driver) Z-phase pulse (open-collector)
12	DIO interface	input/output: sink/source

Item		MR-J3-_T_ and MR-J3-D01	MR-J4-_A_-RJ and MR-D01
13	Analog input/output	[MR-J3-D01] (Input) 2ch Analog torque limit, Override (Output) 12-bit or equivalent × 2ch	[MR-J4-_A_-RJ] (Input) 2ch Analog torque limit, Override (Output) 10-bit or equivalent × 2ch [MR-D01] (Input) 2ch Analog torque limit, Override (Output) 12-bit or equivalent × 2ch [MR-J4-_A_-RJ and MR-D01] The analog inputs (analog torque limit and override) of MR-J4-_A_-RJ and MR-D01 are mutually exclusive functions. They cannot be used together.
14	Parameter setting method	Setup software (SETUP221E) MR Configurator2	MR Configurator2 Push button
15	Setup software communication function	USB	USB
16	Servo motor (Encoder resolution)	HF-_P_ series (18-bit ABS) HA-_P_ series (18-bit ABS)	HG series (22-bit ABS)
17	Motor maximum torque	HF-SP 300%	HG-SR 300%
		HF-JP 300%	HG-JR 300%
		HA-LP 250%	HG-JR 300%
18	LED display	7-segment 3-digit	7-segment 5-digit
19	Advanced vibration suppression control	Provided	Provided (Advanced vibration suppression control II)
20	Adaptive filter II	Provided	Provided
21	Notch filter	Provided (2 pcs)	Provided (5 pcs)
22	Tough drive	Unprovided	Provided
23	Drive recorder	Unprovided	Provided
24	Forced stop	EM1 (DB stop)	EM1 (DB stop)/EM2 (deceleration to a stop)

Note. For the coasting distance, refer to "1.2.3 Dynamic brake: coasting distance" in "Part 8 Common Reference Material".

(3) 100 V class

Item	MR-J3-_T_ and MR-J3-D01	MR-J4-_A_-RJ and MR-D01
1	Capacity range	0.1 to 0.4 kW/100 V
2	Internal regenerative resistor	None (0.1 kW) Built-in (0.2, 0.4 kW)
3	Dynamic brake	Built-in (0.1 to 0.4 kW) Coasting distance may differ. (Note)
4	Control circuit power	1-phase 100 V AC to 120 V AC
5	Main circuit power	1-phase 100 V AC to 120 V AC (0.1 to 0.4 kW)
6	24 V DC power	External supply required
7	Auto Tuning	Real-time auto tuning: 32 steps Advanced gain search
8	Positioning mode	Point table method
9	Point table method	Automatic operation mode <ul style="list-style-type: none"> • Automatic operation with a point table • Automatic operation by BCD (3 digits 2) input with the MR-DS60 6-digit digital switch • Automatic operation by BCD (3 digits 2) input with the programmable controllers Manual operation mode <ul style="list-style-type: none"> • JOG operation– • Manual pulse generator operation Home position return mode <ul style="list-style-type: none"> • Dog type home position return • Count type home position return • Data set type home position return • Stopper type home position return • Home position ignorance (servo-on position as home position) • Dog type rear end reference home position return • Count type front end reference home position return • Dog cradle type home position return • Dog type last Z-phase reference home position return • Dog type front end reference home position return type • Dogless Z-phase reference home position return type • Automatic retract function used for the home position return • Automatic positioning to home position function Roll feed mode using the roll feed display function
10	Pulse input	Manual pulse generator (only for MR-HDP01) Open collector Pulse resolution: 1000 pulses/rev Maximum speed: Instantaneous maximum 600 r/min, normal 200 r/min
11	Encoder pulse output	A/B/Z-phase pulse (differential line driver) Z-phase pulse (open-collector)
12	DIO interface	input/output: sink/source

Part 6: Review on Replacement of MR-J3-_T_(DIO command/ Serial communication operation) with MR-J4-_A_-RJ

Item		MR-J3-_T_ and MR-J3-D01	MR-J4-_A_-RJ and MR-D01
13	Analog input/output	[MR-J3-D01] (Input) 2ch Analog torque limit, Override (Output) 12-bit or equivalent × 2ch	[MR-J4-_A_-RJ] (Input) 2ch Analog torque limit, Override (Output) 10-bit or equivalent × 2ch [MR-D01] (Input) 2ch Analog torque limit, Override (Output) 12-bit or equivalent × 2ch [MR-J4-_A_-RJ and MR-D01] The analog inputs (analog torque limit and override) of MR-J4-_A_-RJ and MR-D01 are mutually exclusive functions. They cannot be used together.
14	Parameter setting method	Setup software (SETUP221E) MR Configurator2	MR Configurator2 Push button
15	Setup software communication function	USB	USB
16	Servo motor (Encoder resolution)	HF-_P_ series (18-bit ABS) HA-_P_ series (18-bit ABS)	HG series (22 -bit ABS)
17	Motor maximum torque	HF-KP 350% HF-MP 300%	HG-KR 350% HG-MR 300%
18	LED display	7-segment 3-digit	7-segment 5-digit
19	Advanced vibration suppression control	Provided	Provided (Advanced vibration suppression control II)
20	Adaptive filter II	Provided	Provided
21	Notch filter	Provided (2 pcs)	Provided (5 pcs)
22	Tough drive	Unprovided	Provided
23	Drive recorder	Unprovided	Provided
24	Forced stop	EM1 (DB stop)	EM1 (DB stop)/EM2 (deceleration to a stop)

Note. For the coasting distance, refer to "1.2.3 Dynamic brake: coasting distance" in "Part 8 Common Reference Material".

(4) Extension I/O unit

POINT
<p>●The extension I/O units, MR-J3-D01 and MR-D01 have the same functions and performance. Therefore, the existing MR-J3-D01 can be used as it is.</p>

Extension I/O unit	MR-J3-D01	MR-D01
Item		
Function	Additional digital input/output, additional analog input/output, external digital display connection	
Digital input	Photocoupler insulation, 24 V DC (external supply) source/sink compatible, internal limited resistance 5.6 kΩ	
Digital output	16 points Photocoupler insulation, open-collector 24 V DC (external supply) source/sink compatible, Permissible current: 40 mA or less, Inrush current: 100 mA or less	
Analog input	2 channel input voltage: -10 V DC to +10 V DC, internal resistor: 12 kΩ Resolution: 12 bits	
Analog output	2 channel input voltage: -12 V DC to +12 V DC, internal resistor: 1 mA Resolution: 12 bits	
+15 V output for analog input signal	Available as analog input signal power supply Output voltage: 15 V Permissible current: 30 mA	
-12 V output for analog input signal	Available as analog input signal power supply Output voltage: -12 V Permissible current: 30 mA	
Mass	140 g	

3.1.1 DIO command/Serial communication operation specifications

Item		Description		
Servo amplifier model		MR-J3-_T_ and MR-J3-D01	MR-J4-_A_-RJ and MR-D01 (Note 2)	
Command method	Point table number input	Positioning with specification of point table No. (255 points)		
	Position command input	Absolute value command method	Set in the point table. Setting range of feed length per point: -999999 to 999999 [$\times 10^{STM}$ μm] ※STM set values: 0 to 3	Set in the point table. Setting range of feed length per point: -999999 to 999999 [$\times 10^{STM}$ μm] ※STM set values: 0 to 3
		Incremental value command method	Set in the point table. Setting range of feed length per point: 0 to 999999 [$\times 10^{STM}$ μm] ※STM set values: 0 to 3	Set in the point table. Setting range of feed length per point: 0 to 999999 [$\times 10^{STM}$ μm] ※STM set values: 0 to 3
	Speed command input	Set the acceleration/deceleration time constants in the point table. Set the S-pattern acceleration/deceleration time constants with [Pr. PC13].	Set the acceleration/deceleration time constants in the point table. Set the S-pattern acceleration/deceleration time constants with [Pr. PC03] .	
	System	Signed absolute value command method/incremental value command method		
Position command data input	BCD input (Note 1)	Absolute value command method	Signed 6-digit BCD digital switch or contact input 1-point feed length setting range: -999999 to 999999 [$\times 10^{STM}$ μm] ※STM set values: 0 to 3	Signed 6-digit BCD digital switch or contact input Setting range of feed length: -999999 to 999999 [$\times 10^{STM}$ μm] ※STM set values: 0 to 3
		Incremental value command method		
	Speed command input	The motor speed and acceleration/deceleration time of the point table No. 1 to 15 is selected by contact input. Set the S-pattern acceleration/deceleration time constants with [Pr. PC13].	The motor speed and acceleration/deceleration time of the point table No. 1 to 15 is selected by contact input. Set the S-pattern acceleration/deceleration time constants with [Pr. PC03] .	
	System	Signed absolute value command method/incremental value command method		
	RS-422 communication	Position command input	Absolute value command method	Setting of position command data with RS-422 communication 1-point feed length setting range: -999999 to 999999 [$\times 10^{STM}$ μm] ※STM set values: 0 to 3
Incremental value command method			Setting of position command data with RS-422 communication 1-point feed length setting range: 0 to 999999 [$\times 10^{STM}$ μm] ※STM set values: 0 to 3	Setting of position command data with RS-422 communication Setting range of feed length per point: 0 to 999999 [$\times 10^{STM}$ μm] ※STM set values: 0 to 3
Speed command input		The motor speed and acceleration/deceleration time is set via RS-422 communication. Set the S-pattern acceleration/deceleration time constants with [Pr. PC13].	The motor speed and acceleration/deceleration time is set via RS-422 communication. Set the S-pattern acceleration/deceleration time constants with [Pr. PC03] .	
System		Signed absolute value command method/incremental value command method		
Operation mode	Automatic operation mode	Point table	Point table No. input method/position data input method Operates each positioning based on position command and speed command.	
		Automatic continuous operation	Varying-speed operation (2 to 255 speeds)/automatic continuous positioning operation (2 to 255 points)	Varying-speed operation (2 to 255 speeds)/automatic continuous positioning operation (2 to 255 points)/ automatic continuous operation to a point table selected at startup/automatic continuous operation to the point table No. 1
	Manual operation mode	JOG operation	Executes a contact input or an inching operation with the RS-422 communication function based on speed command set with parameters.	Executes a contact input or an inching operation with the RS-422 communication function based on speed command set with parameters.
		Manual pulse generator operation	Manual feeding is executed with a manual pulse generator. Command pulse multiplication: select from $\times 1$, $\times 10$, and $\times 100$ with a parameter.	
Home position return mode	Dog type	Returns to home position upon Z-phase pulse after passing through the proximity dog. home position address settable/home position shift amount settable/home position return direction selectable/ automatic retract on dog back to home position/automatic stroke retract function		

Item		Description	
Servo amplifier model		MR-J3-_T_ and MR-J3-D01	MR-J4-_A_-RJ and MR-D01 (Note 2)
Operation mode	Home position return mode	Count type	Returns to home position upon the encoder pulse count after touching the proximity dog. Home position return direction selectable/home position shift amount settable/home position address settable/ automatic retract on dog back to home position/automatic stroke retract function
		Data set type	Returns to home position without dog. Sets any position as a home position using manual operation, etc./home position address settable
		Stopper type	Returns to home position upon hitting the stroke end. Home position return direction selectable/home position address settable
		Home position ignorance (servo-on position as home position)	Sets a home position where SON (Servo-on) signal turns on. Home position address settable
		Dog type rear end reference	Returns to home position based on the rear end of the proximity dog. Home position return direction selectable/home position shift amount settable/home position address settable/ automatic retract on dog back to home position/automatic stroke retract function
		Count type front end reference	Returns to home position based on the front end of the proximity dog. Home position return direction selectable/home position shift amount settable/home position address settable/ automatic retract on dog back to home position/automatic stroke retract function
		Dog cradle type	Returns to home position upon the first Z-phase pulse based on the front end of the proximity dog. Home position return direction selectable/home position shift amount settable/home position address settable/ automatic retract on dog back to home position/automatic stroke retract function
		Dog type last Z-phase reference	Returns to home position upon the Z-phase pulse right before the proximity dog based on the front end of the proximity dog. Home position return direction selectable/home position shift amount settable/home position address settable/ automatic retract on dog back to home position/automatic stroke retract function
		Dog type front end reference	Returns to home position to the front end of the dog based on the front end of the proximity dog. Home position return direction selectable/home position shift amount settable/home position address settable/ automatic retract on dog back to home position/automatic stroke retract function
		Dogless Z-phase reference	Returns to home position to the Z-phase pulse with respect to the first Z-phase pulse. Home position return direction selectable/home position shift amount settable/home position address settable
		Automatic positioning to home position function	
Other functions		Absolute position detection/backlash compensation/overtravel prevention with external limit switch (LSP/LSN)/software stroke limit/mark detection function/override	

- Note 1. BCD input is available only for when MR-D01 has been mounted.
 2. MR-D01 may not be required depending on how MR-J3-_T_ and MR-J3-D01 are used.

3.1.2 Function list

The following table lists the functions of MR-J3-_T_ and MR-J4-_A_-RJ servo amplifier. For details of the functions, refer to each servo amplifier instruction manual.

POINT
●Functions with difference are shown with shading.

Function	MR-J3-_T_ (DIO command/Serial communication operation)	MR-J4-_A_-RJ
Positioning by automatic operation	Select the required ones from among 31 preset point tables and perform operation in accordance with the set values. To select point tables, use external input signals (when using MR-J3-D01) or communication function.	Set 1 to 255 point tables in advance, and select any point table to perform operation in accordance with the set values. To select point tables, use external input signals or communication function.
Varied speed operation	Servo motor speed can be varied continuously until the preset moving distance is reached. (Max. set speeds: 255 speeds)	Servo motor speed can be varied continuously until the preset moving distance is reached. (Max. set speeds: 255 speeds)
Automatic continuous positioning operation	By merely choosing one point table and starting operation, positioning can be executed continuously in accordance with several point tables.	By merely choosing one point table and starting operation, positioning can be executed continuously in accordance with several point tables.
Home position return	Dog type/count type/data setting type/stopper type/home position ignorance/dog type rear end reference/count type front end reference/dog cradle type/dog type last Z-phase reference/dog type Z-phase reference/dogless Z-phase reference	Dog type/count type/data setting type/stopper type/home position ignorance/dog type rear end reference/count type front end reference/dog cradle type/dog type last Z-phase reference/dog type Z-phase reference/dogless Z-phase reference
High-resolution encoder	High-resolution encoder of 262144 pulses/rev is used as a servo motor encoder.	High-resolution encoder of 4194304 pulses/rev is used as the encoder of the rotary servo motor compatible with the MELSERVO-J4 series.
Absolute position detection system	By merely setting the home position once, home position return need not be done at each power on.	Home position return is required only once, and not required at every power on.
Gain changing function	You can switch between gains during rotation and gains during stop or use an input device to change gains during operation.	You can switch gains during rotation/stop, and can use input devices to switch gains during operation.
Advanced vibration suppression control	<Advanced vibration suppression control> This function suppresses vibration at the arm end or residual vibration.	<Advanced vibration suppression control II> This function suppresses vibration at the arm end or residual vibration.
Adaptive filter II	Servo amplifier detects mechanical resonance and sets filter characteristics automatically to suppress mechanical vibration.	Servo amplifier detects mechanical resonance and sets filter characteristics automatically to suppress mechanical vibration.
Low-pass filter	Suppresses high-frequency resonance which occurs as servo system response is increased.	Suppresses high-frequency resonance which occurs as servo system response is increased.
Machine analyzer function	Analyzes the frequency characteristic of the mechanical system by simply connecting a Setup software (SETUP221E) installed personal computer and servo amplifier. Setup software (SETUP221E) is necessary for this function.	Analyzes the frequency characteristic of the mechanical system by simply connecting an MR Configurator2 installed personal computer and servo amplifier. MR Configurator2 is necessary for this function.
Robust disturbance compensation	<Robust disturbance compensation> This function provides better disturbance response in case low response level that load to motor inertia ratio is high for such as roll send axes. Setup software (SETUP221E) is necessary for this function.	<Robust filter> This function provides better disturbance response in case low response level that load to motor inertia ratio is high for such as roll send axes.
Slight vibration suppression control	Suppresses vibration of 1 pulse produced at a servo motor stop. [Pr. PB24]	Suppresses vibration of ±1 pulse generated at a servo motor stop. [Pr. PB24]

Function	MR-J3-_T_ (DIO command/Serial communication operation)	MR-J4-_A_-RJ
Electronic gear	The electronic gear is used to make adjustment so that the servo amplifier setting matches the machine moving distance. Also, changing the electronic gear value allows the machine to be moved at any multiplication ratio to the moving distance using the servo amplifier. [Pr. PA06]/[Pr. PA07]	Position commands can be multiplied by 1/864 to 33935. Select "J3 electronic gear setting value compatibility mode" with [Pr. PA21]. [Pr. PA06]/ [Pr. PA07]
Auto tuning	Automatically adjusts the gain to optimum value if load applied to the servo motor shaft varies.	Automatically adjusts the gain to optimum value if load applied to the servo motor shaft varies.
S-pattern acceleration/deceleration time constant	Acceleration/deceleration can be made smoothly. [Pr. PC13]	This enables to start/stop the servo motor smoothly.
Regenerative option	Used when the built-in regenerative resistor of the servo amplifier does not have sufficient regenerative capability for the regenerative power generated.	Used when the built-in regenerative resistor of the servo amplifier does not have sufficient regenerative capability for the regenerative power generated.
Brake unit	Used when the regenerative option cannot provide enough regenerative power. Can be used with the servo amplifier of 5kW or more.	Used when the regenerative option cannot provide enough regenerative power. Can be used with the servo amplifier of 5kW or more.
Regeneration converter	Used when the regenerative option cannot provide enough regenerative power. Can be used with the servo amplifier of 5kW or more.	Used when the regenerative option cannot provide enough regenerative power. Can be used with the servo amplifier of 5kW or more.
Alarm history clear	Alarm history is cleared. [Pr. PC18]	Alarm history is cleared. [Pr. PC18]
I/O signal selection (Device setting)	Input devices such as servo-on (SON) can be assigned to certain pins of the CN6 connector (MR-J3-_T_) and the CN10 connector (MR-J3-D01). [Pr. PD06] to [Pr. PD08], [Pr. Po02] to [Pr. Po07]	ST1 (Forward rotation start), ST2 (Reverse rotation start), SON (Servoon), and other input device can be assigned to any pins of the CN1 connector of MR-J4-_A_-RJ. [Pr. PD04]/[Pr. PD06]/[Pr. PD08]/[Pr. PD10]/ [Pr. PD12]/[Pr. PD14]/[Pr. PD18]/[Pr. PD20]/ [Pr. PD22]/[Pr. PD44]/[Pr. PD46]
Output signal selection (device settings)	Output devices such as Malfunction (ALM) and Dynamic brake interlock (DB) can be assigned to certain pins of the CN6 connector (MR-J3-_T_) and the CN10 connector (MR-J3-D01). [Pr. PD09] to [Pr. PD11], [Pr. Po08]/[Pr. Po09]	The output devices including MBR (Electromagnetic brake interlock) can be assigned to certain pins of the CN1 connector of MR-J4-_A_-RJ. [Pr. PD23] to [Pr. PD26]/[Pr. PD28]/[Pr. PD47]
Torque limit	Servo motor torque can be limited to any value.	Servo motor torque can be limited to any value. [Pr. PA11]/[Pr. PA12]
Override (Speed limit)	Limits the servo motor speed with analog inputs from MR-J3-D01. A value can be changed from 0% to 200% for a set speed.	Limits the servo motor speed with analog inputs from MR-J4-_A_-RJ. (However, the analog inputs of MR-J4-_A_-RJ and MR-D01 are mutually exclusive.) A value can be changed from 0% to 200% for a set speed.
Output signal (DO) forced output	Output signal can be forced on/off independently of the servo status. Use this function for output signal wiring check, etc.	Output signal can be forced on/off independently of the servo status. Use this function for checking output signal wiring, etc.
Test operation mode	JOG operation positioning operation DO forced output. In the test operation mode, a parameter unit or Setup software (SETUP221E) is required.	Jog operation/positioning operation/motor-less operation/DO forced output/program operation/single-step feed However, MR Configurator2 is necessary for positioning operation, program operation, and single-step feed.
Limit switch	The servo motor travel region can be limited using the forward rotation stroke end (LSP)/reverse rotation stroke end (LSN).	Limits travel intervals using LSP (Forward rotation stroke end) and LSN (Reverse rotation stroke end).
Software limit	The travel region is limited using parameters in terms of address. The function similar to that of a limit switch is limited by parameter.	Limits travel intervals by address using parameters. Enables the same function with the limit switch by setting parameters.

Part 6: Review on Replacement of MR-J3-_T_(DIO command/ Serial communication operation) with MR-J4-_A_-RJ

Function	MR-J3-_T_ (DIO command/Serial communication operation)	MR-J4-_A_-RJ
Serial communication	Serial communication function of RS-422, this servo amplifier enables servo operation, parameter change, monitor function, etc.	You can operate servo driving, parameter change, monitor function, etc. using RS-422 communication (Mitsubishi Electric general-purpose AC servo protocol). Select "equivalent to MR-J3-T" with [Pr. PT01]. Refer to section 4.1 for details.
BCD input	When MR-J3-D01 is mounted, position command input data can be input in 3-digit BCD format.	When MR-D01 is mounted, position command input data can be input in 3-digit BCD format.

3.2 Configuration including auxiliary equipment

(1) MR-J3-_T_ and MR-J3-D01 (DIO command)

The diagram shows MR-J3-100T or less, for 3-phase or 1-phase 200 V to 230 V AC

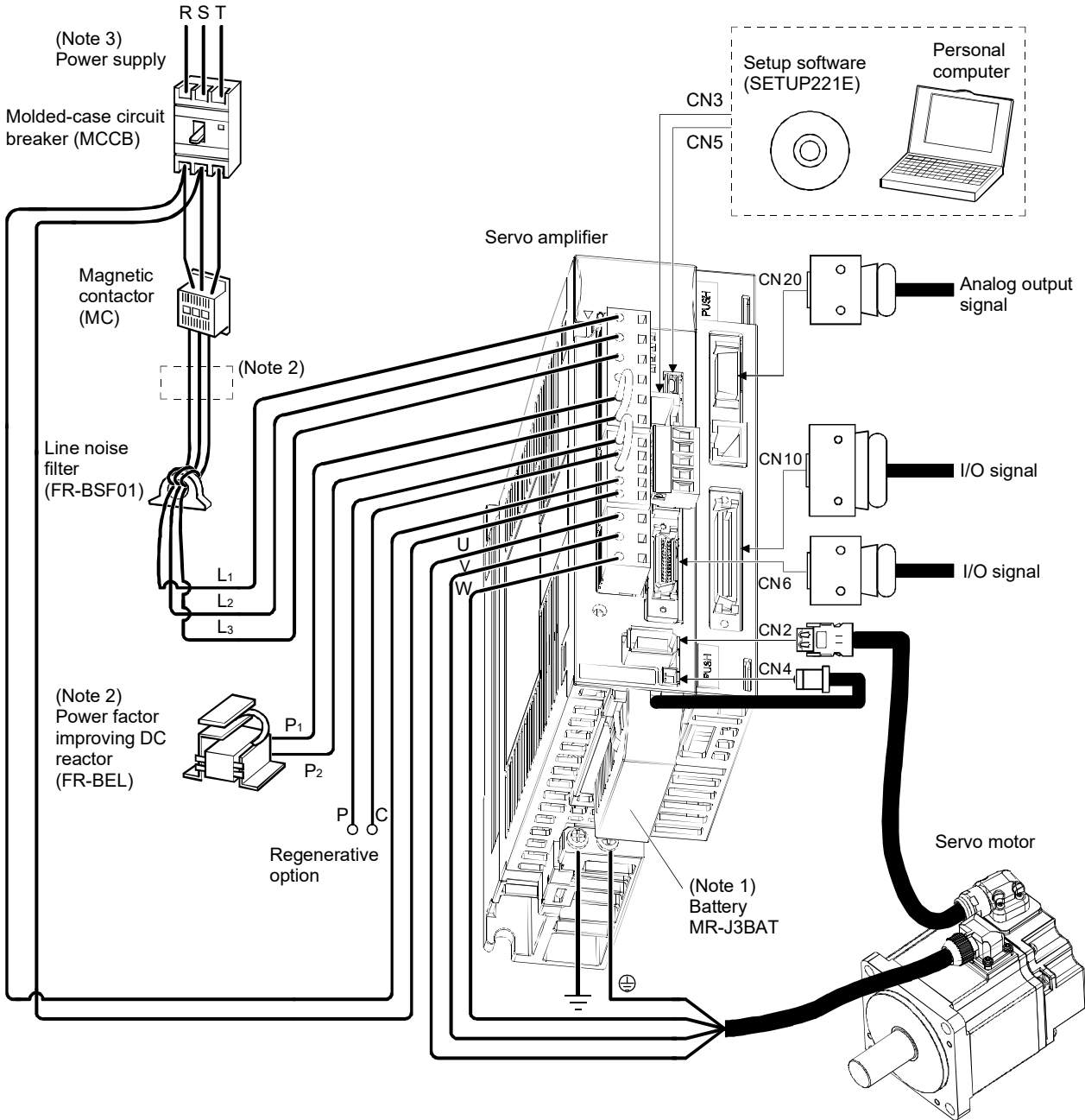

- Note 1. The battery (option) is used for the absolute position detection system in the position control mode.
- Note 2. The AC reactor can also be used. In this case, the DC reactor cannot be used. When not using DC reactor, short P1 and P2.
- Note 3. 1-phase 200 V to 230 V AC power supply may be used with the servo amplifier of MR-J3-70T or less.
For 1-phase 200 V to 230 V AC, connect the power supply to L1/L2 and leave L3 open. Refer to "section 3.1 Function Comparison Table (3)" for the power supply.

(2) MR-J3-_T_(Serial communication operation)

The diagram shows MR-J3-100T or less, for 3-phase or 1-phase 200 V to 230 V AC

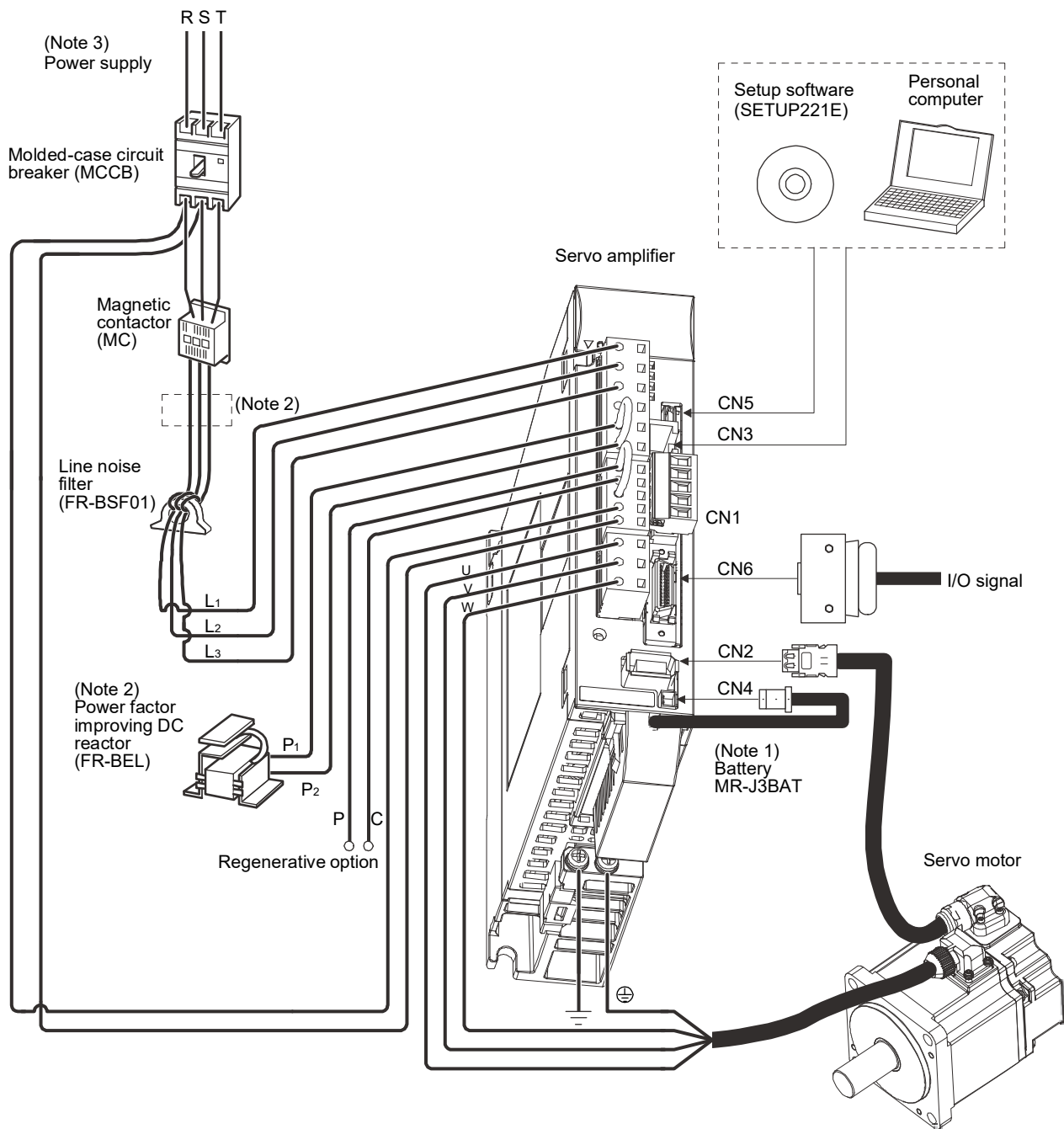

- Note
1. The battery (option) is used for the absolute position detection system in the position control mode.
 2. The power factor improving AC reactor can also be used. In this case, the power factor improving DC reactor cannot be used. When not using power factor improving DC reactor, short P1 and P2.
 3. 1-phase 200 V to 230 V AC power supply may be used with the servo amplifier of MR-J3-70T or less.
For 1-phase 200 V to 230 V AC, connect the power supply to L1/L2 and leave L3 open. Refer to "section 3.1 Function Comparison Table (3)" for the power supply.

(3) MR-J4-_A_-RJ + MR-D01

The following figure shows the interface of when MR-D01 is connected to MR-J4-20A-RJ.

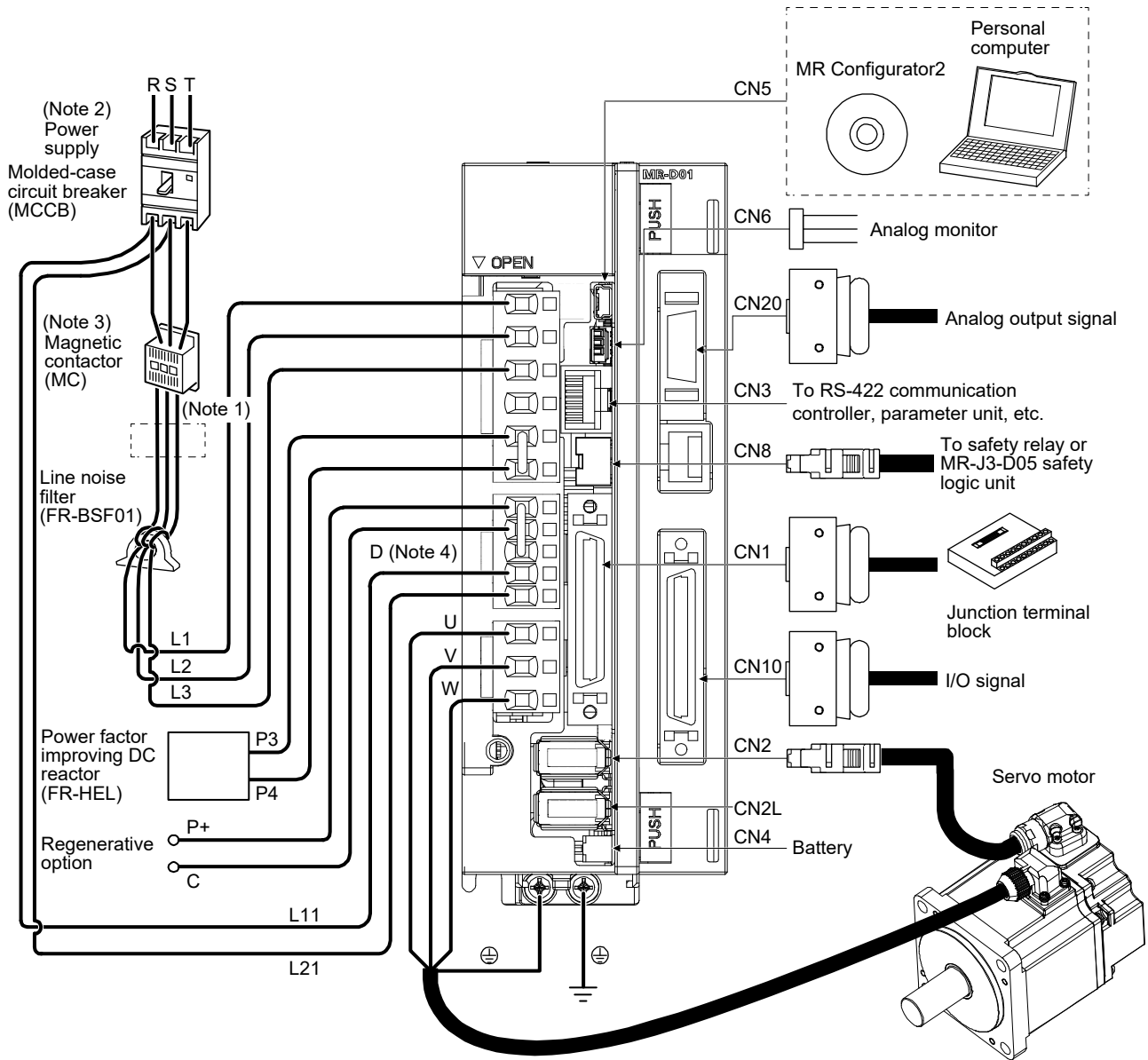

- Note 1. The power factor improving AC reactor can also be used. In this case, the power factor improving DC reactor cannot be used. When not using the power factor improving DC reactor, short P3 and P4.
- Note 2. A 1-phase 200 V AC to 240 V AC power supply may be used with the servo amplifier of MR-J4-200A-RJ or less. For 1-phase 200 V AC to 240 V AC, connect the power supply to L1 and L3. Leave L2 open. For power supply specifications, refer to section 1.3 of "MR-J4-_A_-RJ)/MR-J4-03A6(-RJ) Servo Amplifier Instruction Manual".
- Note 3. Depending on the main circuit voltage and operation pattern, a bus voltage may drop, causing dynamic brake deceleration during forced stop deceleration. When dynamic brake deceleration is not required, delay the time to turn off the magnetic contactor.
- Note 4. Always connect between P+ and D terminals. When using the regenerative option, refer to section 11.2 of "MR-J4-_A_-RJ)/MR-J4-03A6(-RJ) Servo Amplifier Instruction Manual".

(4) MR-J4-_A_-RJ

The following illustration is an example of MR-J4-20A-RJ.

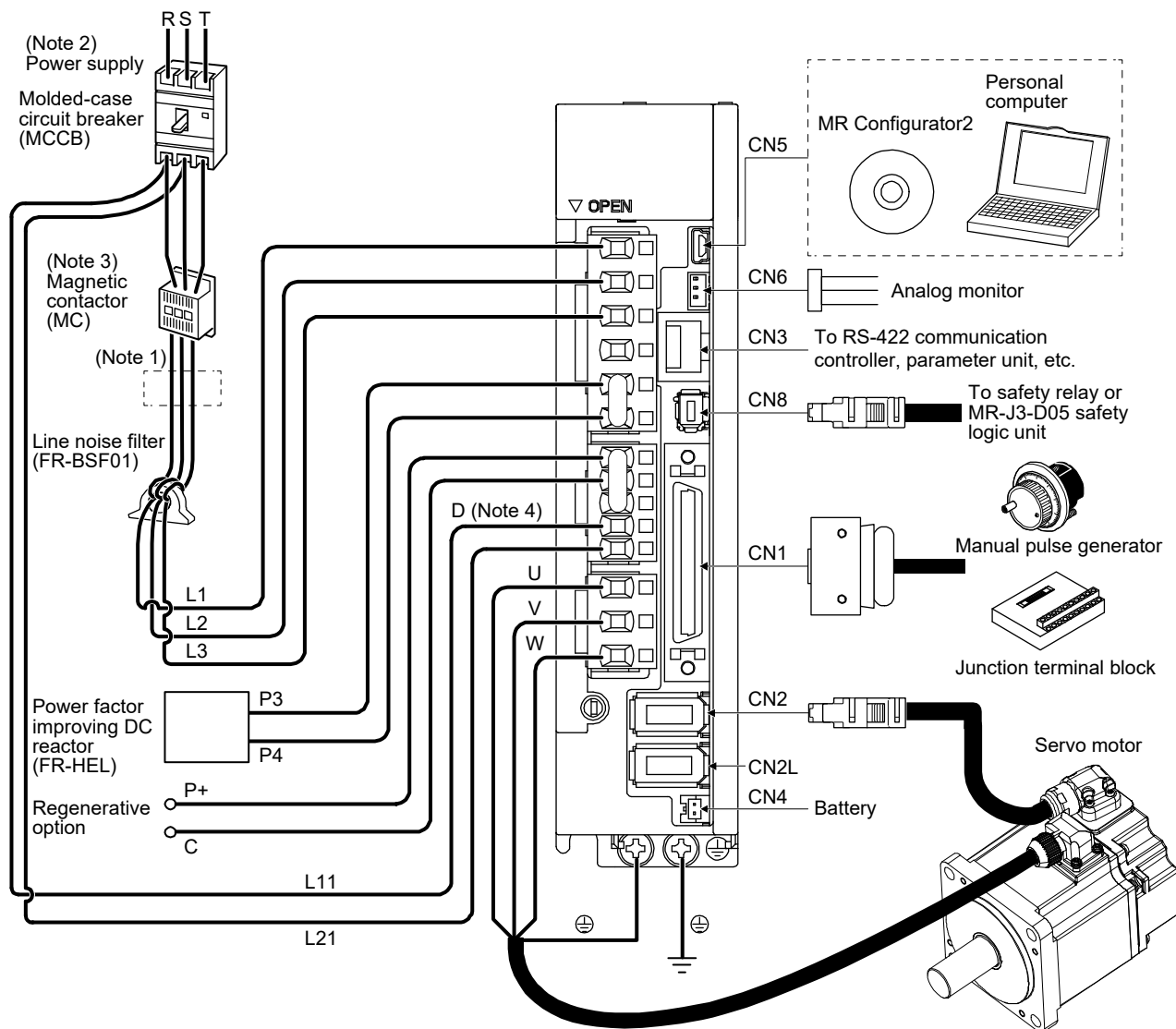

- Note 1. The power factor improving AC reactor can also be used. In this case, the power factor improving DC reactor cannot be used. When not using the power factor improving DC reactor, short P3 and P4.
- Note 2. A 1-phase 200 V AC to 240 V AC power supply may be used with the servo amplifier of MR-J4-200A-RJ or less. For 1-phase 200 V AC to 240 V AC, connect the power supply to L1 and L3. Leave L2 open. For power supply specifications, refer to section 1.3 of "MR-J4-_A_(-RJ)/MR-J4-03A6(-RJ) Servo Amplifier Instruction Manual".
- Note 3. Depending on the main circuit voltage and operation pattern, bus voltage decreases, and that may cause the forced stop deceleration to shift to the dynamic brake deceleration. When dynamic brake deceleration is not required, slow the time to turn off the magnetic contactor.
- Note 4. Always connect between P+ and D terminals. When using the regenerative option, refer to section 11.2 of "MR-J4-_A_(-RJ)/MR-J4-03A6(-RJ) Servo Amplifier Instruction Manual".

3.3 Comparison of Standard Connection Diagrams

(1) MR-J3-_T_ and MR-J3-D01/MR-J4-_A_-RJ and MR-D01 (DIO command)
 (a) Point table method

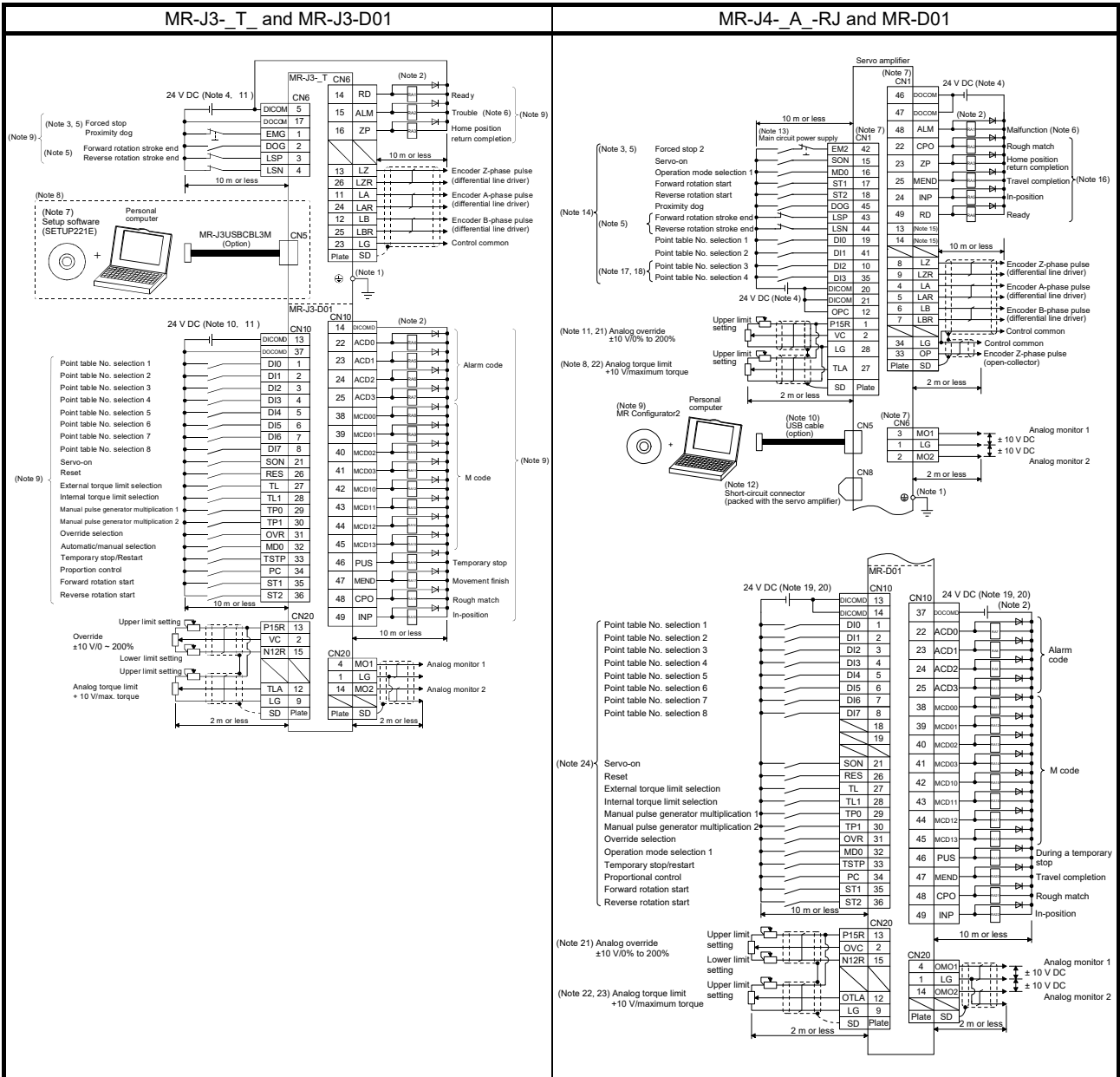

- Note 1. To prevent an electric shock, always connect the protective earth (PE) terminal (terminal marked ⊕) of the servo amplifier to the protective earth (PE) of the control box.
2. Connect the diode in the correct direction. If it is connected reversely, the servo amplifier or the MR-J3-D01 will be faulty and will not output signals, disabling the forced stop (EMG) and other protective circuits.
3. The forced stop switch (normally closed contact) must be installed.
4. Supply 24 V DC ± 10% 150 mA current for interfaces of the servo amplifier from the outside. 150 mA is the value applicable when all I/O signals are used. The current capacity can be decreased by reducing the number of I/O points. Refer to section 3.8.2 (1) of "MR-J3-_T_/MR-J3-D01 Servo Amplifier Instruction Manual" that gives the current value necessary for the interface.
5. When starting operation, always turn on forced stop (EMG) and Forward/Reverse rotation stroke end (LSP/LSN). (Normally closed contacts)
6. Trouble (ALM) turns on in normal alarm-free condition.
7. Use MRJZW3-SETUP 211E.

- Note 1. To prevent an electric shock, always connect the protective earth (PE) terminal (marked ⊕) of the servo amplifier to the protective earth (PE) of the cabinet.
2. Connect the diode in the correct direction. If it is connected reversely, the servo amplifier will malfunction and will not output signals, disabling EM2 (Forced stop 2) and other protective circuits.
3. The forced stop switch (normally closed contact) must be installed.
4. Supply 24 V DC ± 10% to interfaces from outside. The total current capacity of these power supplies must be 500 mA or lower. 500 mA is the value applicable when all I/O signals are used. The current capacity can be decreased by reducing the number of I/O points. Refer to section 3.9.2 (1) of "MR-J4-_A_-RJ/MR-J4-03A6(-RJ) Servo Amplifier Instruction Manual" that gives the current value necessary for the interface. A 24 V DC power supply can be used for both input signal and output signal.
5. When starting operation, always turn on EM2 (Forced stop 2), LSP (Forward rotation stroke end) and LSN (Reverse rotation stroke end). (Normally closed contact)
6. ALM (Malfunction) turns on in normal alarm-free condition. (Normally closed contact)

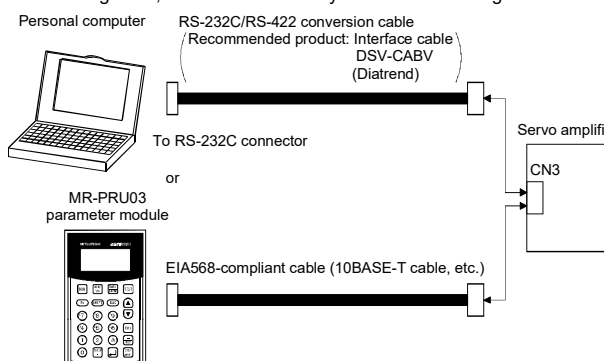
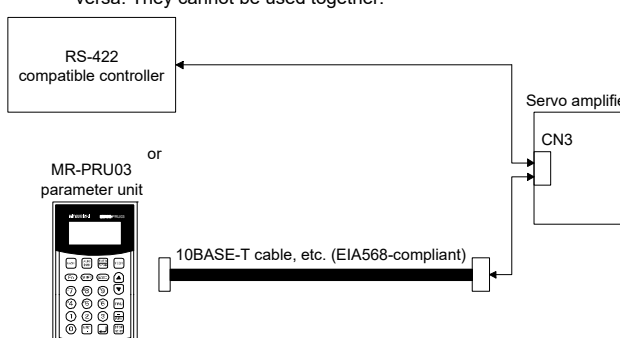
MR-J3-_T_ and MR-J3-D01	MR-J4-_A_-RJ and MR-D01
<p>8. Personal computers or parameter modules can also be connected via the CN3 connector, enabling RS-422 communication. Note that using the USB communication function (CN5 connector) prevents the RS-422 communication function (CN3 connector) from being used, and vice versa. They cannot be used together.</p>  <p>9. For the sink I/O interface. For the source I/O interface, refer to section 3.8.2 (1) of "MR-J3-_T_/MR-J3-D01 Servo Amplifier Instruction Manual"</p> <p>10. Supply 24 V DC 10% 800 mA current for interfaces of the servo amplifier from the outside. 800 mA is the value applicable when all I/O signals are used. The current capacity can be decreased by reducing the number of I/O points. Refer to section 3.8.2 (1) of "MR-J3-_T_/MR-J3-D01 Servo Amplifier Instruction Manual" that gives the current value necessary for the interface.</p> <p>11. The 24 V DC for I/O signal can be supplied to the servo amplifier and MR-J3-D01 with one 24VDC power supply. In this case, use the power supply capacity corresponding to the points of the I/O signal to be used.</p>	<p>7. The pins with the same signal name are connected in the servo amplifier.</p> <p>8. TLA will be available when TL (External torque limit selection) is enabled with [Pr. PD04], [Pr. PD06], [Pr. PD08], [Pr. PD10], [Pr. PD12], [Pr. PD14], [Pr. PD18], [Pr. PD20], [Pr. PD22], [Pr. PD44], and [Pr. PD46]. (Refer to section 3.6.1 (5) of "MR-J4-_A_-RJ/MR-J4-03A6(-RJ) Servo Amplifier Instruction Manual".)</p> <p>9. Use SW1DNC MRC2-_. (Refer to "MR-J4-_A_-RJ/MR-J4-03A6(-RJ) Servo Amplifier Instruction Manual" section 11.7.)</p> <p>10. Controllers or parameter units can also be connected via the CN3 connector with the RS-422 communication. Note that using the USB communication function (CN5 connector) prevents the RS-422 communication function (CN3 connector) from being used, and vice versa. They cannot be used together.</p>  <p>11. Use an external power supply when inputting a negative voltage.</p> <p>12. When not using the STO function, attach the short-circuit connector came with a servo amplifier.</p> <p>13. Configure a circuit to turn off EM2 when the main circuit power is turned off to prevent an unexpected restart of the servo amplifier.</p> <p>14. The devices can be changed with [Pr. PD04], [Pr. PD06], [Pr. PD08], [Pr. PD10], [Pr. PD12], [Pr. PD14], [Pr. PD18], [Pr. PD20], [Pr. PD22], [Pr. PD44], and [Pr. PD46].</p> <p>15. Output devices are not assigned by default. Assign the output devices with [Pr. PD47] as necessary.</p> <p>16. Recommended device assignments are shown. The devices can be changed by [Pr. PD23] to [Pr. PD26], and [Pr. PD28].</p> <p>17. DI2 and DI3 are assigned to the CN1-10 and CN1-35 pins by default. When connecting a manual pulse generator, change them with [Pr. PD44] and [Pr. PD46]. Refer to section 9.1 of "MR-J4-_A_-RJ(Positioning mode) Servo Amplifier Instruction Manual" for details of the manual pulse generator.</p> <p>18. Supply + of 24 DC V to OPC (Power input for open-collector sink interface) when input devices are assigned to the CN1-10 pin and the CN-35 pin. They cannot be used with source input interface. For the positioning mode, input devices (DI2 and DI3) are assigned with the initial values.</p> <p>19. Supply 24 V DC \pm 10% to interfaces of the MR-D01 from outside. The total current capacity of these power supplies must be 800 mA or lower. 800 mA is the value applicable when all I/O signals are used. The current capacity can be decreased by reducing the number of I/O points. For the current required for the interface, refer to section 3.8.2 (1) of "MR-J4-_A_-RJ/MR-J4-03A6(-RJ) Servo Amplifier Instruction Manual".</p> <p>20. As the 24 V DC for the input/output signals, one 24 V DC power supply can be used to supply to the servo amplifier and MRD01. In this case, select an appropriate power supply capacity depending on the number of points of the input/output signals to be used.</p> <p>21. The CN1-2 pin and CN20-2 pin are exclusive. The CN1-2 pin is set by default. Select this item with [Pr. Po11].</p> <p>22. The CN1-27 pin and CN20-12 pin are exclusive. The CN1-27 pin is set by default. Select this item with [Pr. Po11].</p> <p>23. OTLA will be available when TL (External torque limit selection) is enabled with [Pr. Po02] to [Pr. Po07]. (Refer to section 11.5.3 (6) of "MR-J4-_A_-RJ/MR-J4-03A6(-RJ) Servo Amplifier Instruction Manual (Positioning mode)".)</p> <p>24. The devices can be changed by [Pr. Po02] to [Pr. Po07]. When BCD input positioning operation is not used, MR-D01 is unnecessary.</p>

(b) Point table method in the BCD input positioning operation

POINT

● For notes, refer to (1) (a) of this section.

1) When using a digital switch

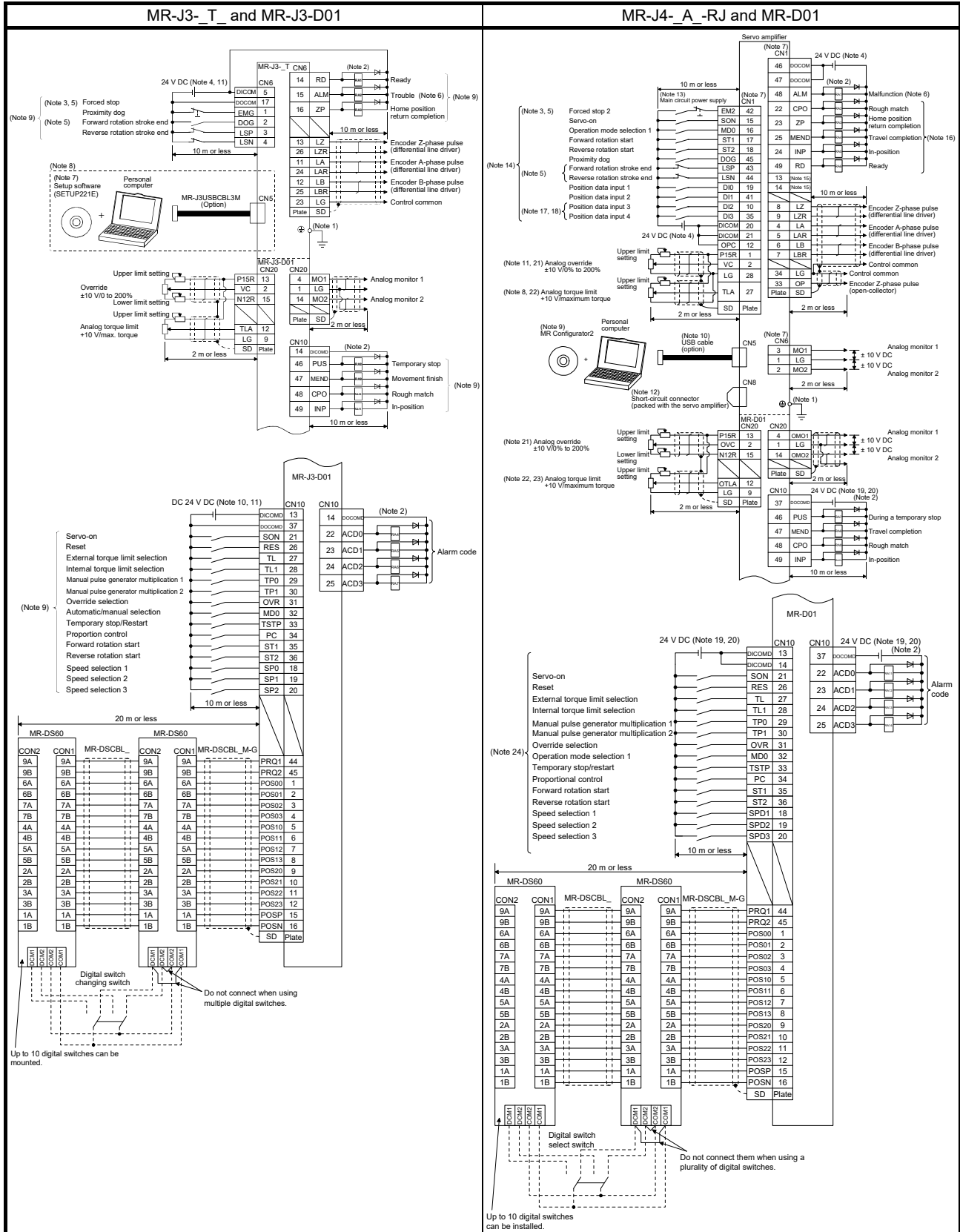

2) When using a programmable controllers

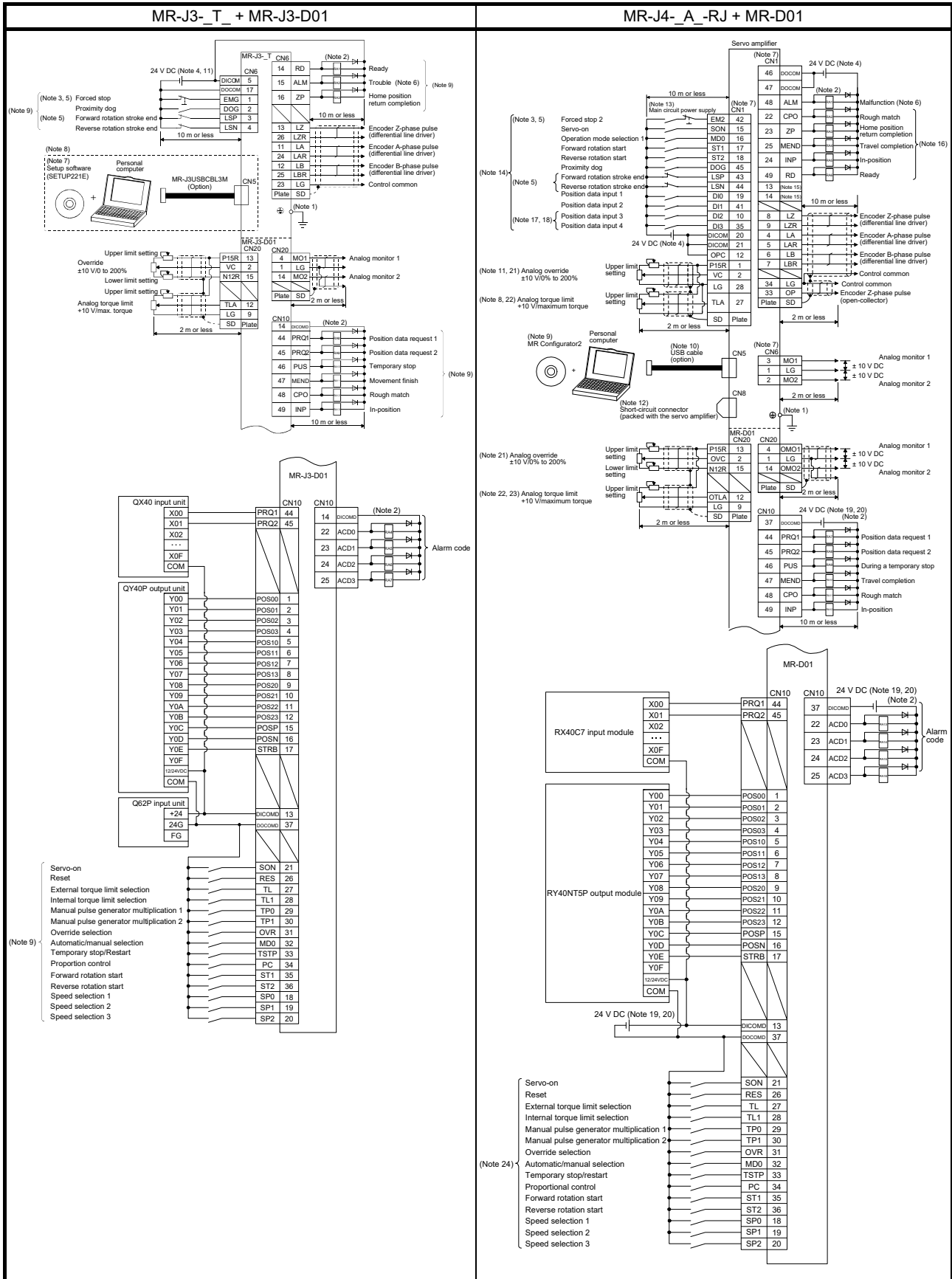

(2) MR-J3-_T_/MR-J4-_A_-RJ (Serial communication operation)

MR-J3-_T_

MR-J3-_T_

MR-J4-_A_-RJ

MR-J4-_A_-RJ

Note 1. To prevent an electric shock, always connect the protective earth (PE) terminal (terminal marked ⊕) of the servo amplifier to the protective earth (PE) of the control box.

2. Connect the diode in the correct direction. If it is connected reversely, the servo amplifier or the MR-J3-D01 will be faulty and will not output signals, disabling the forced stop (EMG) and other protective circuits.
3. The forced stop switch (normally closed contact) must be installed.
4. Supply 24VDC 10% 150 mA current for interfaces of the servo amplifier from the outside. 150 mA is the value applicable when all I/O signals are used. The current capacity can be decreased by reducing the number of I/O points. Refer to section 3.8.2 (1) of "MR-J3-_T_/MR-J3-D01 Servo Amplifier Instruction Manual" that gives the current value necessary for the interface. "MR-J3-_T_/MR-J3-D01
5. When starting operation, always turn on forced stop (EMG) and Forward/Reverse rotation stroke end (LSP/LSN). (Normally closed contacts)
6. Trouble (ALM) turns on in normal alarm-free condition.
7. Use MRZJW3-SETUP 211E.
8. Personal computers or parameter modules can also be connected via the CN3 connector, enabling RS-422 communication.
Note that using the USB communication function (CN5 connector) prevents the RS-422 communication function (CN3 connector) from being used, and vice versa. They cannot be used together.

Personal computer or MR-PRU03 parameter module connected to Servo amplifier CN3 via RS-232C/RS-422 conversion cable (Recommended product: DSV-CABV (Diatrend)) or EIA568-compliant cable (10BASE-T cable, etc.).

9. For the sink I/O interface. For the source I/O interface, refer to section 3.8.3 of "MR-J3-_T_/MR-J3-D01 Servo Amplifier Instruction Manual".
10. In this case, select a power supply capacity suitable for the number of input and output signals used. One 24 V DC power supply can be used for the input and output signals and the servo amplifier.

Note 1. To prevent an electric shock, always connect the protective earth (PE) terminal (marked ⊕) of the servo amplifier to the protective earth (PE) of the cabinet.

2. Connect the diode in the correct direction. If it is connected reversely, the servo amplifier will malfunction and will not output signals, disabling EM2 (Forced stop 2) and other protective circuits.
3. The forced stop switch (normally closed contact) must be installed.
4. Supply 24 V DC ± 10% to interfaces from outside. The total current capacity is up to 500 mA. 500 mA is the value applicable when all I/O signals are used. The current capacity can be decreased by reducing the number of I/O points. Refer to section 3.9.2 (1) of "MR-J4-_A_-RJ/MR-J4-03A6(-RJ) Servo Amplifier Instruction Manual" that gives the current value necessary for the interface. A 24 V DC power supply can be used for both input signal and output signal.
5. When starting operation, always turn on EM2 (Forced stop 2), LSP (Forward rotation stroke end) and LSN (Reverse rotation stroke end) (normally closed contact).
6. ALM (Malfunction) turns on in normal alarm-free condition (normally closed contact).
7. The pins with the same signal name are connected in the servo amplifier.
8. TLA will be available when TL (External torque limit selection) is enabled with [Pr. PD04], [Pr. PD06], [Pr. PD08], [Pr. PD10], [Pr. PD12], [Pr. PD14], [Pr. PD18], [Pr. PD20], [Pr. PD22], [Pr. PD44], and [Pr. PD46]. (Refer to section 3.6.1 (5) of "MR-J4-_A_-RJ/MR-J4-03A6(-RJ) Servo Amplifier Instruction Manual".)
9. Use SW1DNC-MRC2-_ (Refer to section 11.7 of "MR-J4-_A_-RJ/MR-J4-03A6(-RJ) Servo Amplifier Instruction Manual".)
10. Controllers or parameter units can also be connected via the CN3 connector with the RS-422/RS-485 communication. Note that using the USB communication function (CN5 connector) prevents the RS-422 communication function (CN3 connector) from being used, and vice versa. They cannot be used together.

RS-422 compatible controller or MR-PRU03 parameter unit connected to Servo amplifier CN3 via 10BASE-T cable, etc. (EIA568-compliant).

11. Use an external power supply when inputting a negative voltage.

MR-J3-_T_	MR-J4-_A_-RJ
	<ol style="list-style-type: none"> 12. When not using the STO function, attach the short-circuit connector came with a servo amplifier. 13. Configure a circuit to turn off EM2 when the main circuit power is turned off to prevent an unexpected restart of the servo amplifier. 14. This diagram shows sink I/O interface. 15. The device can be changed with [Pr. PD04], [Pr. PD06], [Pr. PD08], [Pr. PD10], [Pr. PD12], [Pr. PD14], [Pr. PD18], [Pr. PD20], [Pr. PD22], [Pr. PD44], and [Pr. PD46]. 16. These output devices are not assigned by default. Assign the output device with [Pr. PD47] as necessary. 17. These devices are recommended assignments. The device can be changed by [Pr. PD23] to [Pr. PD26], and [Pr. PD28]. 18. DI2 and DI3 are assigned to the CN1-10 and CN1-35 pins by default. When connecting a manual pulse generator, change them with [Pr. PD44] and [Pr. PD46]. Refer to section 9.1 of "MR-J4-_A_-RJ/MR-J4-03A6-RJ Servo Amplifier Instruction Manual (Positioning mode)" for details of the manual pulse generator. 19. Supply + of 24 V DC to OPC (Power input for open-collector sink interface) when input devices are assigned to the CN1-10 pin and the CN1-35 pin. They are not used with source input interface. For the positioning mode, input devices (DI2 and DI3) are assigned by default.

3.4 List of Corresponding Connectors and Terminal Blocks

(1) Connector comparison table

The following shows examples of connections with the peripheral equipment. For details of signals, refer to each servo amplifier instruction manual.

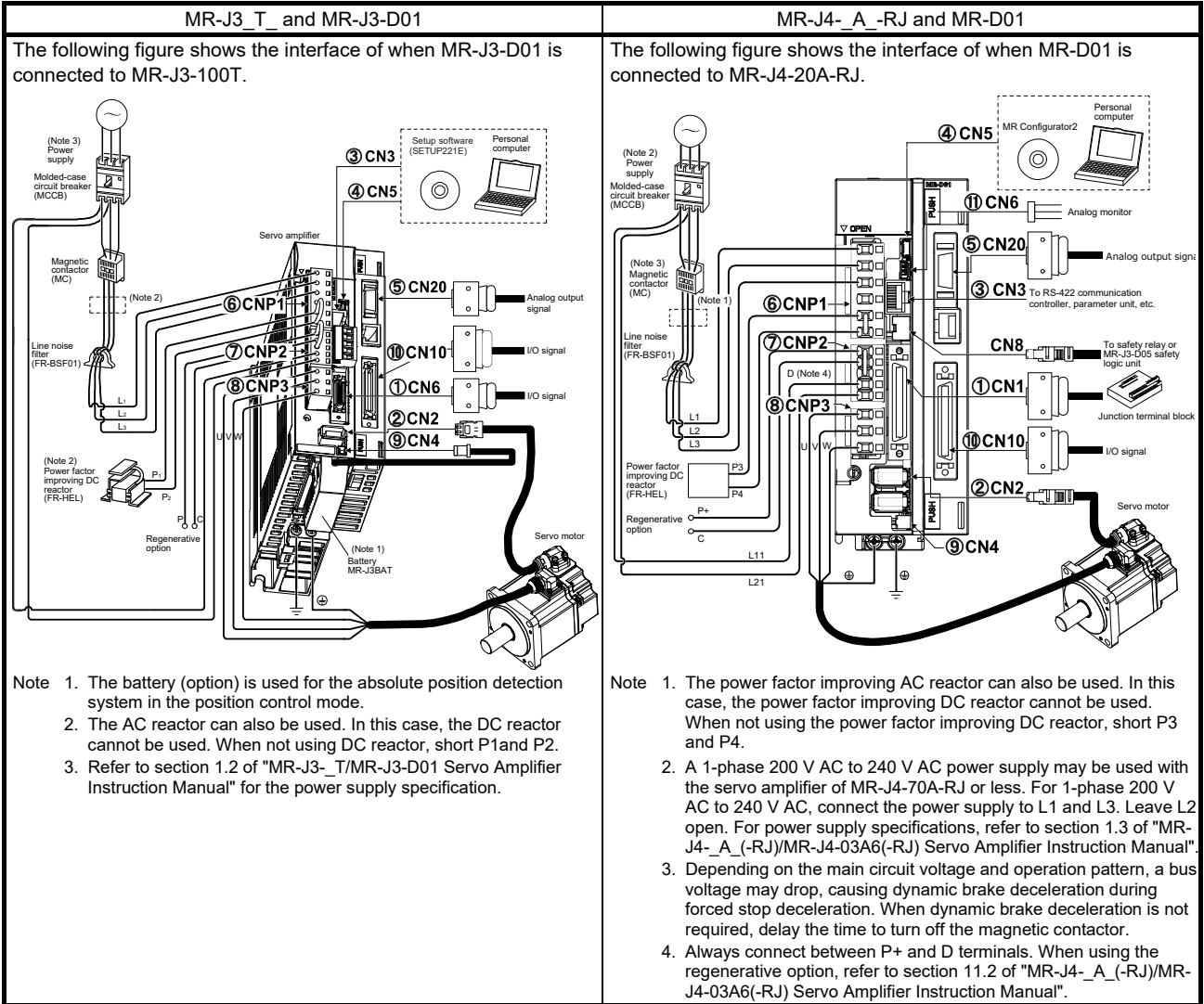

(2) List of connector and terminal block correspondence

MR-J3-_T_ and MR-J3-D01			MR-J4-_A_-RJ and MR-D01			Precautions
No.	Connector name	Connector No.	No.	Connector name	Connector No.	
①	I/O signal connector	CN6	①	I/O signal connector	CN1	Newly required.
②	Encoder connector	CN2	②	Encoder connector	CN2	The cable needs to be changed when using 15 kW or more HG-JR 1000 r/min series or 22 kW or more HG-JR 1500 r/min series is used. (CN2L is not used.)
③	RS-422 communication connector	CN3	③	RS-422 communication connector	CN3	
④	USB communication connector	CN5	④	USB communication connector	CN5	
⑤	Analog input connector	CN20	⑤	Analog input connector	CN20	
⑥	Main circuit power supply connector	CNP1	⑥	Main circuit power supply connector	CNP1	Switch to the power connector (enclosed with the servo amplifier).
⑦	Control circuit connector	CNP2	⑦	Control circuit connector	CNP2	
⑧	Servo motor power output connector	CNP3	⑧	Servo motor power output connector	CNP3	
⑨	Battery connector	CN4	⑨	Battery connector	CN4	Prepare a new battery.
⑩	I/O signal connector	CN10	⑩	I/O signal connector	CN10	
			⑪	Analog monitor connector	CN6	Newly required.

Note. When not using the STO function in MR-J4-_A_-RJ, attach the short-circuit connector supplied with the servo amplifier to CN8 (STO input signal connector).

When MR-J3-_T_ is used with MR-J3-D01, CN1 (CC-Link connector) is not used. Do not connect anything including.

Do not connect anything to the CN30 connector (for manufacturer setting) of MR-J3-D01 and MR-D01.

The structure of the main circuit terminal block varies depending on the capacity. Refer to "Part 8 Common Reference Material".

(3) Comparison of signals

(a) Servo amplifier

Signal abbreviations in parentheses are for MR-J4-_A_-RJ.

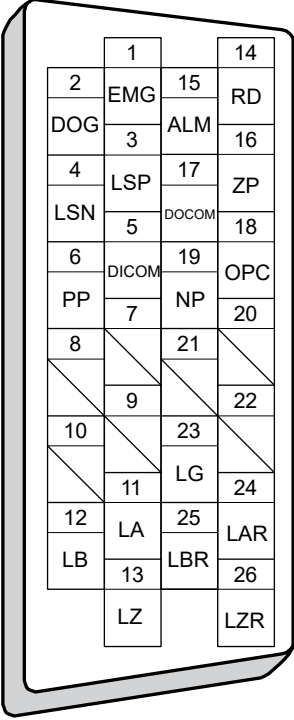
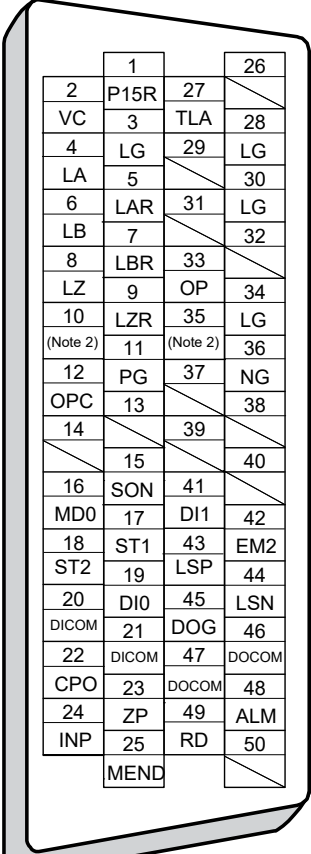
MR-J3-_T_		Abbreviation	MR-J4-_A_-RJ	
Connector pin assignment	Connector pin No.		Connector pin No.	Connector pin assignment
	CN6-1	EMG (EM2)	CN1-42 (Note1)	
	CN6-2	DOG	CN1-45	
	CN6-3	LSP	CN1-43	
	CN6-4	LSN	CN1-44	
	CN6-5	DICOM	CN1-20	
	CN6-6	PP	CN1-21	
	CN6-7		CN1-10 (Note 2)	
	CN6-8			
	CN6-9			
	CN6-10			
	CN6-11	LA	CN1-4	
	CN6-12	LB	CN1-6	
	CN6-13	LZ	CN1-8	
	CN6-14	RD	CN1-49	
	CN6-15	ALM	CN1-48	
	CN6-16	ZP	CN1-23 (Note 3)	
	CN6-17	DOCOM	CN1-46	
	CN6-18	OPC	CN1-47	
	CN6-19	NP	CN1-12 (Note 2)	
	CN6-20		CN1-35 (Note 2)	
	CN6-21			
	CN6-22			
	CN6-23	LG	CN1-3	
			CN1-28	
			CN1-30	
			CN1-34	
CN6-24	LAR	CN1-5		
CN6-25	LBR	CN1-7		
CN6-26	LZR	CN1-9		

- Note 1. In the initial setting, EM2 is assigned to the CN1-42 pin. To configure the same settings as for MR-J3-_T_, select "Forced stop deceleration function disabled (with EM1 used)". To use EM1, set [Pr. PA04] to "0 _ _ _".
- Note 2. Input devices are not assigned to the CN1-10 pin and the CN1-35 pin by default. To assign PP and NP, set [Pr. PD44] and [Pr. PD46] to "0 0 _ _". In addition, supply + of 24 V DC to the CN1-12 pin.
- Note 3. To enable the CN1-23 pin, set [Pr. PD24] to "_ _ 2 4".

(b) CN6 (MR-J4-_A_-RJ only)

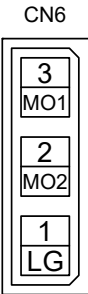
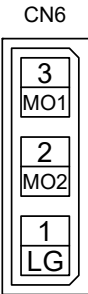
MR-J3-_T_		Signal abbreviation	MR-J4-_A_-RJ	
Connector pin assignment	Connector pin No.		Connector pin No.	Connector pin assignment
	/	LG	CN6-1	
	/	MO2	CN6-2	
	/	MO1	CN6-3	

(c) CN3

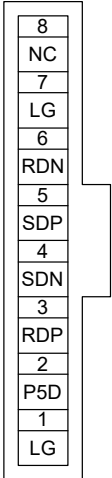
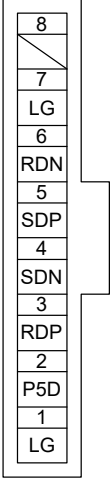
MR-J3-_T_		Signal abbreviation	MR-J4-_A_-RJ	
Connector pin assignment	Connector pin No.		Connector pin No.	Connector pin assignment
	CN3-1	LG	CN3-1	
	CN3-2	P5D	CN3-2	
	CN3-3	RDP	CN3-3	
	CN3-4	SDN	CN3-4	
	CN3-5	SDP	CN3-5	
	CN3-6	RDN	CN3-6	
	CN3-7	LG	CN3-7	
	CN3-8	NC (-)	CN3-8	

(d) Extension I/O unit.

1) CN10: Point table method

MR-J3-D01		Signal	MR- D01	
Connector pin assignment		abbreviation	Connector pin No.	Connector pin assignment
			CN10-1	
		DI0	CN10-2	
		DI1	CN10-3	
		DI2	CN10-4	
		DI3	CN10-5	
		DI4	CN10-6	
		DI5	CN10-7	
		DI6	CN10-8	
		DI7	CN10-9	
			CN10-10	
			CN10-11	
			CN10-12	
		DICOMD	CN10-13	
		DICOMD	CN10-14	
			CN10-15	
			CN10-16	
			CN10-17	
			CN10-18	
			CN10-19	
			CN10-20	
		SON	CN10-21	
		ACD0	CN10-22	
		ACD1	CN10-23	
		ACD2	CN10-24	
		ACD3	CN10-25	
		RES	CN10-26	
		TL	CN10-27	
		TL1	CN10-28	
		TP0	CN10-29	
		TP1	CN10-30	
		OVR	CN10-31	
		MD0	CN10-32	
		TSTP	CN10-33	
		PC	CN10-34	
		ST1	CN10-35	
		ST2	CN10-36	
		DOCOMD	CN10-37	
		MCD00	CN10-38	
		MCD01	CN10-39	
		MCD02	CN10-40	
		MCD03	CN10-41	
		MCD10	CN10-42	
		MCD11	CN10-43	
		MCD12	CN10-44	
		MCD13	CN10-45	
		PUS	CN10-46	
		MEND	CN10-47	
		CPO	CN10-48	
		INP	CN10-49	
		SD	CN10-50	

CN10

CN10

2) CN10: Point table method in the BCD input positioning operation
 Signal abbreviations in parentheses are for MR-J4- A -RJ.

MR-J3-D01		Signal	MR- D01	
Connector pin assignment	Connector pin No.	abbreviation	Connector pin No.	Connector pin assignment
	CN10-1	POS00	CN10-1	
	CN10-2	POS01	CN10-2	
	CN10-3	POS02	CN10-3	
	CN10-4	POS03	CN10-4	
	CN10-5	POS10	CN10-5	
	CN10-6	POS11	CN10-6	
	CN10-7	POS12	CN10-7	
	CN10-8	POS13	CN10-8	
	CN10-9	POS20	CN10-9	
	CN10-10	POS21	CN10-10	
	CN10-11	POS22	CN10-11	
	CN10-12	POS23	CN10-12	
	CN10-13	DICOMD	CN10-13	
	CN10-14	DICOMD	CN10-14	
	CN10-15	POSP	CN10-15	
	CN10-16	POSN	CN10-16	
	CN10-17	STRB	CN10-17	
	CN10-18	SP0 (SPD1)	CN10-18	
	CN10-19	SP1 (SPD2)	CN10-19	
	CN10-20	SP2 (SPD3)	CN10-20	
	CN10-21	SON	CN10-21	
	CN10-22	ACD0	CN10-22	
	CN10-23	ACD1	CN10-23	
	CN10-24	ACD2	CN10-24	
	CN10-25	ACD3	CN10-25	
	CN10-26	RES	CN10-26	
	CN10-27	TL	CN10-27	
	CN10-28	TL1	CN10-28	
	CN10-29	TP0	CN10-29	
	CN10-30	TP1	CN10-30	
	CN10-31	OVR	CN10-31	
	CN10-32	MD0	CN10-32	
	CN10-33	TSTP	CN10-33	
	CN10-34	PC	CN10-34	
	CN10-35	ST1	CN10-35	
	CN10-36	ST2	CN10-36	
	CN10-37	DOCOMD	CN10-37	
	CN10-38		CN10-38	
	CN10-39		CN10-39	
	CN10-40		CN10-40	
	CN10-41		CN10-41	
	CN10-42		CN10-42	
	CN10-43		CN10-43	
	CN10-44	PRQ1	CN10-44	
	CN10-45	PRQ2	CN10-45	
	CN10-46	PUS	CN10-46	
	CN10-47	MEND	CN10-47	
	CN10-48	CPO	CN10-48	
	CN10-49	INP	CN10-49	
	CN10-50	SD	CN10-50	

CN10

50		25	
SD	49	ACD3	24
48	INP	23	ACD2
CPO	47	ACD1	22
46	MEND	21	ACD0
PUS	45	SON	20
44	PRQ2	19	SP2
PRQ1	43	SP1	18
42		17	SP0
	41	STRB	16
40		15	POSN
	39	POSP	14
38		13	DICOMD
	37	DICOMD	12
36	DOCOMD	11	POS23
ST2	35	POS22	10
34	ST1	9	POS21
PC	33	POS20	8
32	TSTP	7	POS13
MD0	31	POS12	6
30	OVR	5	POS11
TP1	29	POS10	4
28	TP0	3	POS03
TL1	27	POS02	2
26	TL	1	POS01
RES			POS00

CN10

50		25	
SD	49	ACD3	24
48	INP	23	ACD2
CPO	47	ACD1	22
46	MEND	21	ACD0
PUS	45	SON	20
44	PRQ2	19	SPD3
PRQ1	43	SPD2	18
42		17	SPD1
	41	STRB	16
40		15	POSN
	39	POSP	14
38		13	DICOMD
	37	DICOMD	12
36	DOCOMD	11	POS23
ST2	35	POS22	10
34	ST1	9	POS21
PC	33	POS20	8
32	TSTP	7	POS13
MD0	31	POS12	6
30	OVR	5	POS11
TP1	29	POS10	4
28	TP0	3	POS03
TL1	27	POS02	2
26	TL	1	POS01
RES			POS00

3) CN20

Signal abbreviations in parentheses are for MR-D01.

MR-J3-D01		Signal abbreviation	MR- D01	
Connector pin assignment	Connector pin No.		Connector pin No.	Connector pin assignment
	CN20-1	LG	CN20-1	
	CN20-2	VC (OVC)	CN20-2 (Note 1)	
	CN20-3		CN20-3	
	CN20-4	M01 (OM01)	CN20-4	
	CN20-5		CN20-5	
	CN20-6		CN20-6	
	CN20-7		CN20-7	
	CN20-8		CN20-8	
	CN20-9	LG	CN20-9	
	CN20-10		CN20-10	
	CN20-11	LG	CN20-11	
	CN20-12	TLA (OTLA)	CN20-12 (Note 2)	
	CN20-13	P15R	CN20-13	
	CN20-14	M02 (OM02)	CN20-14	
	CN20-15	N12R	CN20-15	
	CN20-16		CN20-16	
	CN20-17		CN20-17	
	CN20-18		CN20-18	
	CN20-19		CN20-19	
	CN20-20		CN20-20	

- Note 1. To use this signal, set [Pr. Po11] to " _ _ 1 _ " and enable the CN20-2 pin. When MR-D01 has not been connected, setting "1" will trigger [AL. 37 Parameter error].
- Note 2. To use this signal, set [Pr. Po11] to " _ _ 1 _ " and enable the CN20-12 pin. When MR-D01 has not been connected, setting "1" will trigger [AL. 37].

3.5 Comparison of Peripheral Equipment

POINT
● Refer to "Part 10: Replacement of Optional Peripheral Equipment".

3.5.1 MR-J3-_T_/MR-J4-_A_-RJ

The following tables show the items that are newly required when MR-J3-_T_ is replaced with MR-J4-_A_-RJ.

Prepare the items newly to use MR-J4-_A_-RJ. Refer to "MR-J4-_A_-(-RJ)/MR-J4-03A6(-RJ) Servo Amplifier Instruction Manual" for details.

- (1) Junction terminal block for connecting I/O signal connectors/Junction terminal block cable/Junction terminal block connector set

Item	MR-J3-_T_	MR-J4-_A_-RJ
Junction terminal block	MR-TB26A	MR-TB50
Junction terminal block cable	MR-TBNATBL_M	MR-J2M-CN1TBL_M
Junction terminal block connector set	MR-J2CMP2	MR-J3CN1

- (2) Monitor cable

Item	MR-J3-_T_	MR-J4-_A_-RJ
Monitor cable		MR-J3CN6CBL1M

3.5.2 Extension I/O unit

Cable for connecting extension I/O units/Comparison of connector sets

Item	MR-J3-D01	MR-D01	Compatibility (Note)	Remarks
Junction terminal block	MR-TB50		○	Always use the junction terminal block MR-TB50 with the junction terminal block cable MR-J2M-CN1TBL_M as a set.
	PS7DW-20V14B-F		○	The junction terminal block PS7DW-20V14B-F is not an option from us. For using the junction terminal block, our option MR-J2HBUS_M is necessary.
Junction terminal block cable	MR-J2HBUS_M		○	
Connector set	MR-J3CN1		○	
	MR-CCN1		○	
Digital switch cable	MR-DSCBL_M-G		○	
	MR-DSCBL_		○	

Note. ○: Compatible

3.6 Comparison of Parameters

	CAUTION	<ul style="list-style-type: none"> ● Never perform extreme adjustments and changes to the parameters, otherwise the operation may become unstable. ● If fixed values are written in the digits of a parameter, do not change these values. ● Do not change parameters for manufacturer setting. ● Do not enter any setting value other than those specified for each parameter.
---	---------	---

POINT	<ul style="list-style-type: none"> ● For the parameter converter function, refer to "Part 8: Common Reference Material". ● To enable a parameter whose abbreviation is preceded by *, turn the power OFF and then ON after setting the parameter. ● For details about parameter settings for replacement, refer to the "MR-J4-_A_-RJ/MR-J4-03A6-RJ Servo Amplifier Instruction Manual (Positioning mode)". ● With MR-J4-_A_-RJ, the deceleration to a stop function is enabled by factory settings. To disable the deceleration to a stop function, set [Pr. PA04] to "0 __ _". ● To enable read/write the positioning control parameters ([Pr. PT__]), set [Pr. PA19 Parameter writing inhibit] to "0 0 A B".
-------	---

3.6.1 Setting requisite parameters upon replacement

The parameters shown in this section are a minimum number of parameters that need to be set for simultaneous replacement. Depending on the settings of the currently used amplifier, parameters other than these may need to be set.

MR-J3-_T_ (DIO command/Serial communication operation)		MR-J4-_A_-RJ		Precautions	
No.	Name	No.	Name		
PA01	Control mode	PT01	Command mode selection	For details, refer to "section 3.6.3 Comparison of parameter details".	
		PA01	Operation mode		
PA02	Regenerative option	PA02	Regenerative option		
PA03	Absolute position detection system	PA03	Absolute position detection system		
PA04	Function selection A-1	PT02	Function selection T-1		
		PA04	Function selection A-1		
PA05	Feeding function selection	PT03	Feeding function selection		
		PC29	Function selectionC-8		
PA06	Electronic gear numerator (Command input pulse multiplication numerator)	PA06	Electronic gear numerator (Command input pulse multiplication numerator)		
PA07	Electronic gear denominator (Command pulse multiplying factor denominator)	PA07	Electronic gear denominator (Command pulse multiplying factor denominator)		
PA08	Auto tuning	PA08	Auto tuning mode		
PA09	Auto tuning response	PA09	Auto tuning response		
PA10	In-position range	PA10	In-position range		
PA11	Forward torque limit	PA11	Forward rotation torque limit		
PA12	Reverse torque limit	PA12	Reverse rotation torque limit		
PA14	Rotation direction selection	PA14	Servo motor rotation direction selection/travel direction selection		
PA15	Encoder output pulses	PA15	Encoder output pulses		
PA19	Parameter write inhibit	PA19	Parameter writing inhibit		To enable read/write the positioning control parameters ([Pr. PT__]), set [Pr. PA19 Parameter writing inhibit] to "0 0 A B".

Part 6: Review on Replacement of MR-J3-_T_(DIO command/ Serial communication operation) with MR-J4-_A_-RJ

MR-J3-_T_ (DIO command/Serial communication operation)		MR-J4-_A_-RJ		Precautions
No.	Name	No.	Name	
PB06	Load to motor inertia ratio	PB06	Load to motor inertia ratio	The unit system is different. (0.1 times → 0.01 times) Check the setting value.
PB07	Model loop gain	PB07	Model loop gain	The unit system is different. (0.1 times → 0.01 times) Check the setting value.
PB08	Position loop gain	PB08	Position loop gain	The unit system is different. (rad/s → 0.1 rad/s) Check the setting value.
PB12	For manufacturer setting	PB12	Overshoot amount compensation	For details, refer to "section 3.6.3 Comparison of parameter details".
PB17	Automatic setting parameter	PB17	Shaft resonance suppression filter	
PB23	Low-pass filter	PB23	Low-pass filter setting	
PB29	Gain changing ratio of load inertia moment to servo motor inertia moment	PB29	Load to motor inertia ratio/load to motor mass ratio after gain switching	The unit system is different. (0.1 times → 0.01 times) Check the setting value.
PB30	Gain changing position loop gain	PB30	Position loop gain after gain switching	The unit system is different. (rad/s → 0.1 rad/s) The initial value is different. Check the setting value.
PB31	Gain changing speed loop gain	PB31	Speed loop gain after gain switching	The initial value is different. Check the setting value.
PB32	Gain changing speed integral compensation	PB32	Speed integral compensation after gain switching	The initial value is different. Check the setting value.
PB33	Gain changing vibration suppression control vibration frequency setting	PB33	Vibration suppression control 1 - Vibration frequency after gain switching	The initial value is different. Check the setting value.
PB34	Gain changing vibration suppression control resonance frequency setting	PB34	Vibration suppression control 1 - Resonance frequency after gain switching	The initial value is different. Check the setting value.
PC02	Home position return type	PT04	Home position return type	For details, refer to "section 3.6.3 Comparison of parameter details".
PC03	Home position return direction			
PC04	Home position return speed	PT05	Home position return speed	The initial value is different. Check the setting value.
PC05	Creep speed	PT06	Creep speed	For details, refer to "section 3.6.3 Comparison of parameter details".
PC06	Home position shift distance	PT07	Home position shift distance	
PC07	Home position return position data	PT08	Home position return position data	
PC08	Moving distance after proximity dog	PT09	Travel distance after proximity dog	
PC09	Stopper type home position return stopper time	PT10	Stopper type home position return stopper time	
PC10	Stopper type home position return torque limit value	PT11	Stopper type home position return torque limit value	
PC11	Rough match output range	PT12	Rough match output range	
PC12	Jog speed	PT13	JOG operation	
PC13	S-pattern acceleration/deceleration time constant	PC03	S-pattern acceleration/deceleration time constant	
PC14	Backlash compensation	PT14	Backlash compensation	
PC16	Electromagnetic brake sequence output	PC16	Electromagnetic brake sequence output	
PC21	RS-422 communication function selection	PC21	RS-422 communication function selection	For details, refer to "section 3.6.3 Comparison of parameter details".
PC24	Function selection C-3	PC24	Function selection C-3	
PC27	Function selection C-6	PC27	Function selection C-6	
PC28	Function selection C-7	PT26	Function selection T-2	
PC31	Software limit +	PT15	Software limit + (Lower 3 digits)	
PC32		PT16	Software limit + (Upper 3 digits)	
PC33	Software limit -	PT17	Software limit - (Lower 3 digits)	
PC34		PT18	Software limit - (Upper 3 digits)	
PC36	Status display selection	PC36	Status display selection	
PC37	Position range output address +	PT19	Position range output address + (Lower 3 digits)	
PC38		PT20	Position range output address + (Upper 3 digits)	
PC39	Position range output address -	PT21	Position range output address - (Lower 3 digits)	
PC40		PT22	Position range output address - (Upper 3 digits)	

Part 6: Review on Replacement of MR-J3-_T_(DIO command/ Serial communication operation) with MR-J4-_A_-RJ

MR-J3-_T_ (DIO command/Serial communication operation)		MR-J4-_A_-RJ		Precautions
No.	Name	No.	Name	
PD01	Input signal automatic ON selection 1	PD01	Input signal automatic on selection 1	For details, refer to "section 3.6.3 Comparison of parameter details".
PD03	Input signal automatic ON selection 3	PD41	Input signal automatic on selection 3	
PD04	Input signal automatic ON selection 4	PD42	Input signal automatic on selection 4	
PD06	Input signal device selection 2 (CN6-2)	PD04	Input device selection 1H (CN1-15)	Assign the input devices assigned to the CN6-2 pin, the CN6-3 pin, and the CN6-4 pin of MR-J3-_T_ to any pins of MR-J4-_A_-RJ.
PD07	Input signal device selection 3 (CN6-3)	PD06	Input device selection 2H (CN1-16)	
PD08	Input signal device selection 4 (CN6-4)	PD08	Input device selection 3H (CN1-17)	
		PD10	Input device selection4H (CN1-18)	
		PD12	Input device selection 5H (CN1-19)	
		PD14	Input device selection 6H (CN1-41)	
		PD18	Input device selection 8H (CN1-43)	
		PD20	Input device selection 9H (CN1-44)	
		PD22	Input device selection 10H (CN1-45)	
		PD44	Input device selection 11H (CN1-10/CN1-37)	
		PD46	Input device selection 12H (CN1-35/CN1-38)	
PD09	Output signal device selection 1 (CN6-14)	PD23	Output device selection 1 (CN1-22)	Assign the output devices assigned to the CN6-14 pin, the CN6-15 pin, and the CN6-16 pin of MR-J3-_T_ to any pins of MR-J4-_A_-RJ.
PD10	Output signal device selection 2 (CN6-15)	PD24	Output device selection 2 (CN1-23)	
PD11	Output signal device selection 3 (CN6-16)	PD25	Output device selection 3 (CN1-24)	
		PD26	Output device selection 4 (CN1-25)	
		PD28	Output device selection 6 (CN1-49)	
		PD47	Output device selection 7 (CN1-13/CN1-14)	
PD16	Input polarity selection	PT29	Function selection T-3	For details, refer to "section 3.6.3 Comparison of parameter details".
PD19	Response level setting	PD29	Input filter setting	
PD20	Function selection D-1	PD30	Function selection D-1	
PD22	Function selection D-3	PD32	Function selection D-3	
PD24	Function selection D-5	PD34	Function selection D-5	
Po02	MR-J3-D01 input signal device selection 1 (CN10-21/CN10-26)	Po02	MR-D01 input device selection 1	Same as MR-J3-_T_
Po03	MR-J3-D01 input signal device selection 2 (CN10-27/CN10-28)	Po03	MR-D01 input device selection 2	
Po04	MR-J3-D01 input signal device selection 3 (CN10-29/CN10-30)	Po04	MR-D01 input device selection 3	
Po05	MR-J3-D01 input signal device selection 4 (CN10-31/CN10-32)	Po05	MR-D01 input device selection 4	
Po06	MR-J3-D01 input signal device selection 5 (CN10-33/CN10-34)	Po06	MR-D01 input device selection 5	
Po07	MR-J3-D01 input signal device selection 6 (CN10-35/CN10-36)	Po07	MR-D01 input device selection 6	
Po08	MR-J3-D01 output signal device selection 1 (CN10-46/CN10-47)	Po08	MR-D01 output device selection 1	
Po09	MR-J3-D01 output signal device selection 2 (CN10-48/CN10-49)	Po09	MR-D01 output device selection 2	
Po10	Function selection O-1	Po10	Function selection O-1	
Po11	For manufacturer setting	Po11	Function selection O-2	
Po12	Function selection O-3	Po12	Function selection O-3	Same as MR-J3-_T_
Po13	MR-J3-D01 analog monitor output 1	Po13	MR-D01 analog monitor 1 output selection	For details, refer to "section 3.6.3 Comparison of parameter details".
Po14	MR-J3-D01 analog monitor output 2	Po14	MR-D01 analog monitor 2 output selection	Depends on hardware. The setting values must be changed.
Po15	MR-J3-D01 analog monitor 1 offset	Po15	MR-D01 analog monitor 1 offset	
Po16	MR-J3-D01 analog monitor 2 offset	Po16	MR-D01 analog monitor 2 offset	
Po21	MR-J3-D01 override offset	Po21	MR-D01 override offset	
Po22	MR-J3-D01 analog torque limit offset	Po22	MR-D01 analog torque limit offset	
Po27	For manufacturer setting	Po27	MR-D01 input device selection7	Refer to "MR-J4-_A_-RJ/MR-J4-03A6-RJ Servo Amplifier Instruction Manual (Positioning Mode)".
Po28	For manufacturer setting	Po28	MR-D01 input device selection8	

3.6.2 Parameter comparison list

MR-J3-_T_ parameters					MR-J4-_A_-RJ parameters				
No.	Abbreviation	Parameter name	Initial value	Customer setting value	No.	Abbreviation	Parameter name	Initial value	Customer setting value
PA01	*STY	Control mode	0000h		PT01	*CTY	Command mode selection	0000h	
					PA01	*STY	Operation mode	1000h	
PA02	*REG	Regenerative option	0000h		PA02	*REG	Regenerative option	0000h	
PA03	*ABS	Absolute position detection system	0000h		PA03	*ABS	Absolute position detection system	0000h	
PA04	*AOP1	Function selection A-1	0000h		PT02	*TOP1	Function selection T-1	0000h	
					PA04	*AOP1	Function selection A-1	2000h	
PA05	*FTY	Feeding function selection	0000h		PT03	*FTY	Feeding function selection	0000h	
					PC29	*COP8	Function selection C-8	0000h	
PA06	CMX	Electronic gear numerator(command pulse multiplication numerator)	1		PA06	CMX	Electronic gear numerator (command pulse multiplication numerator)	1	
PA07	CDV	Electronic gear denominator (command pulse multiplication denominator)	1		PA07	CDV	Electronic gear denominator (command pulse multiplication denominator)	1	
PA08	ATU	Auto tuning	0001h		PA08	ATU	Auto tuning mode	0001h	
PA09	RSP	Auto tuning response	12		PA09	RSP	Auto tuning response	16	
PA10	INP	In-position range	100		PA10	INP	In-position range	100	
PA11	TLP	Forward torque limit	100.0		PA11	TLP	Forward rotation torque limit	100.0	
PA12	TLN	Reverse torque limit	100.0		PA12	TLN	Reverse rotation torque limit	100.0	
PA14	*POL	Rotation direction selection	0		PA14	*POL	Servo motor rotation direction selection/travel direction selection	0	
PA15	*ENR	Encoder output pulses	4000		PA15	*ENR	Encoder output pulses	4000	
PA19	*BLK	Parameter write inhibit	000Ch		PA19	*BLK	Parameter writing inhibit	00AAh	
PB01	FILT	Adaptive tuning mode (Adaptive filter II)	0000h		PB01	FILT	Adaptive tuning mode (adaptive filter II)	0000h	
PB02	VRFT	Vibration suppression control filter tuning mode (Advanced vibration suppression control)	0000h		PB02	VRFT	Vibration suppression control tuning mode (advanced vibration suppression control II)	0000h	
PB04	FFC	Feed forward gain	0		PB04	FFC	Feed forward gain	0	
PB06	GD2	Ratio of load inertia moment to servo motor inertia moment	7.0		PB06	GD2	Load to motor inertia ratio/load to motor mass ratio	7.00	
PB07	PG1	Model loop gain	24		PB07	PG1	Model loop gain (Note)	15.0	
PB08	PG2	Position loop gain	37		PB08	PG2	Position loop gain (Note)	37.0	
PB09	VG2	Speed loop gain	823		PB09	VG2	Speed loop gain (Note)	823	
PB10	VIC	Speed integral compensation	33.7		PB10	VIC	Speed integral compensation (Note)	33.7	
PB11	VDC	Speed differential compensation	980		PB11	VDC	Speed differential compensation (Note)	980	
PB12		For manufacturer setting	0		PB12	OVA	Overshoot amount compensation	0	
PB13	NH1	Machine resonance suppression filter 1	4500		PB13	NH1	Machine resonance suppression filter 1	4500	
PB14	NHQ1	Notch form selection 1	0000h		PB14	NHQ1	Notch shape selection 1	0000h	
PB15	NH2	Machine resonance suppression filter 2	4500		PB15	NH2	Machine resonance suppression filter 2	4500	
PB16	NHQ2	Notch form selection 2	0000h		PB16	NHQ2	Notch shape selection 2	0000h	
PB17		Automatic setting parameter			PB17	NHF	Shaft resonance suppression filter	0000h	
PB18	LPF	Low-pass filter	3141		PB18	LPF	Low-pass filter setting	3141	
PB19	VRF1	Vibration suppression control vibration frequency setting	100.0		PB19	VRF11	Vibration suppression control 1 - Vibration frequency	100.0	
PB20	VRF2	Vibration suppression control resonance frequency setting	100.0		PB20	VRF12	Vibration suppression control 1 - Resonance frequency	100.0	
PB23	VFBF	Low-pass filter selection	0000h		PB23	VFBF	Low-pass filter selection	0000h	
PB24	*MVS	Slight vibration suppression control selection	0000h		PB24	*MVS	Slight vibration suppression control	0000h	

Note. Parameters related to gain adjustment are different from those for the MR-J3-_T_ servo amplifier. For gain adjustment, refer to "MR-J4-_A_-(-RJ)/MR-J4-03A6(-RJ) Servo Amplifier Instruction Manual".

Part 6: Review on Replacement of MR-J3-_T_(DIO command/ Serial communication operation) with MR-J4-_A_-RJ

MR-J3-_T_ parameters					MR-J4-_A_-RJ parameters				
No.	Abbreviation	Parameter name	Initial value	Customer setting value	No.	Abbreviation	Parameter name	Initial value	Customer setting value
PB26	*CDP	Gain changing selection	0000h		PB26	*CDP	Gain switching function	0000h	
PB27	CDL	Gain changing condition	10		PB27	CDL	Gain switching condition	10	
PB28	CDT	Gain changing time constant	1		PB28	CDT	Gain switching time constant	1	
PB29	GD2B	Gain changing ratio of load inertia moment to servo motor inertia moment	7.0		PB29	GD2B	Load to motor inertia ratio/load to motor mass ratio after gain switching	7.00	
PB30	PG2B	Gain changing position loop gain	37		PB30	PG2B	Position loop gain after gain switching	0.0	
PB31	VG2B	Gain changing speed loop gain	823		PB31	VG2B	Speed loop gain after gain switching	0	
PB32	VICB	Gain changing speed integral compensation	33.7		PB32	VICB	Speed integral compensation after gain switching	0.0	
PB33	VRF1B	Gain changing vibration suppression control vibration frequency setting	100.0		PB33	VRF1B	Vibration suppression control 1 - Vibration frequency after gain switching	0.0	
PB34	VRF2B	Gain changing vibration suppression control resonance frequency setting	100.0		PB34	VRF2B	Vibration suppression control 1 - Resonance frequency after gain switching	0.0	
PC02	*ZTY	Home position return type	0000h		PT04	*ZTY	Home position return type	0010h	
PC03	*ZDIR	Home position return direction	0001h		PT04	*ZTY	Home position return type	0010h	
PC04	ZRF	Home position return speed	500		PT05	ZRF	Home position return speed	100	
PC05	CRF	Creep speed	10		PT06	CRF	Creep speed	10	
PC06	ZST	Home position shift distance	0		PT07	ZST	Home position shift distance	0	
PC07	*ZPS	Home position return position data	0		PT08	*ZPS	Home position return position data	0	
PC08	DCT	Moving distance after proximity dog	1000		PT09	DCT	Travel distance after proximity dog	1000	
PC09	ZTM	Stopper type home position return stopper time	100		PT10	ZTM	Stopper type home position return stopper time	100	
PC10	ZTT	Stopper type home position return torque limit value	15.0		PT11	ZTT	Stopper type home position return torque limit value	15.0	
PC11	CRP	Rough match output range	0		PT12	CRP	Rough match output range	0	
PC12	JOG	Jog speed	100		PT13	JOG	JOG operation	100	
PC13	*STC	S-pattern acceleration/deceleration time constant	0		PC03	STC	S-pattern acceleration/deceleration time constant	0	
PC14	*BKC	Backlash compensation	0		PT14	*BKC	Backlash compensation	0	
PC16	MBR	Electromagnetic brake sequence output	100		PC16	MBR	Electromagnetic brake sequence output	0	
PC17	ZSP	Zero speed	50		PC17	ZSP	Zero speed	50	
PC18	*BPS	Alarm history clear	0000h		PC18	*BPS	Alarm history clear	0000h	
PC19	*ENRS	Encoder output pulse selection	0000h		PC19	*ENRS	Encoder output pulse selection	0000h	
PC20	*SNO	Station number setting	0		PC20	*SNO	Station No. setting	0	
PC21	*SOP	RS-422 communication function selection	0000h		PC21	*SOP	RS-422 communication function selection	0000h	
PC22	*COP1	Function selection C-1	0000h		PC22	*COP1	Function selection C-1	0000h	
PC24	*COP3	Function selection C-3	0000h		PC24	*COP3	Function selection C-3	0000h	
PC26	*COP5	Function selection C-5	0000h		PC26	*COP5	Function selection C-5	0000h	
PC27	*COP6	Function selection C-6	0000h		PC27	*COP6	Function selection C-6	0000h	
PC28	*COP7	Function selection C-7	0000h		PT26	*TOP2	Function selection T-2	0000h	
PC31	LMPL	Software limit+	0		PT15	LMPL	Software limit+	0	
PC32	LMPH				PT16	LMPH			
PC33	LMNL	Software limit-	0		PT17	LMNL	Software limit-	0	
PC34	LMNH				PT18	LMNH			
PC35	TL2	Internal torque limit 2	100.0		PC35	TL2	Internal torque limit 2	100.0	
PC36	*DMD	Status display selection	0000h		PC36	*DMD	Status display selection	0000h	
PC37	*LPPL	Position range output address+	0		PT19	*LPPL	Position range output address +	0	
PC38	*LPPH				PT20	*LPPH			
PC39	*LNPL	Position range output address -	0		PT21	*LNPL	Position range output address-	0	
PC40	*LNPH				PT22	*LNPH			

Part 6: Review on Replacement of MR-J3-_T_(DIO command/ Serial communication operation) with MR-J4-_A_-RJ

MR-J3-_T_ parameters					MR-J4-_A_-RJ parameters				
No.	Abbreviation	Parameter name	Initial value	Customer setting value	No.	Abbreviation	Parameter name	Initial value	Customer setting value
PD01	*DIA1	Input signal automatic ON selection 1	0000h		PD01	*DIA1	Input signal automatic on selection 1	0000h	
PD03	*DIA3	Input signal automatic ON selection 3	0000h		PD41	*DIA3	Input signal automatic on selection 3	0000h	
PD04	*DIA4	Input signal automatic ON selection 4	0000h		PD42	*DIA4	Input signal automatic on selection 4	0000h	
PD06	*DI2	Input signal device selection 2 (CN6-2)	002Bh		PD22	*DI10H	Input device selection 10H	2B23h	
PD07	*DI3	Input signal device selection 3 (CN6-3)	000Ah		PD18	*DI8H	Input device selection 8H	0A00h	
PD08	*DI4	Input signal device selection 4 (CN6-4)	000Bh		PD20	*DI9H	Input device selection 9H	0B00h	
PD09	*DO1	Output signal device selection 1 (CN6-14)	0002h		PD28	*DO6	Output device selection 6	0002h	
PD10	*DO2	Output signal device selection 2 (CN6-15)	0003h						
PD11	*DO3	Output signal device selection 3 (CN6-16)	0024h						
PD16	*DIAB	Input polarity selection	0000h		PD29	*TOP3	Function selection T-3	0000h	
PD19	*DIF	Response level setting	0002h		PD29	*DIF	Input filter setting	0004h	
PD20	*DOP1	Function selection D-1	0010h		PD30	*DOP1	Function selection D-1	0000h	
PD22	*DOP3	Function selection D-3	0000h		PD32	*DOP3	Function selection D-3	0000h	
					PT26	*TOP2	Function selection T-2	0000h	
PD24	*DOP5	Function selection D-5	0000h		PD34	*DOP5	Function selection D-5	0000h	
Po02	*ODI1	MR-J3-D01 input signal device selection 1 (CN10-21, 26)	0302h		Po02	*ODI1	MR-D01 input device selection 1 (CN10-21, 26)	0302h	
Po03	*ODI2	MR-J3-D01 input signal device selection 2 (CN10-27, 28)	0905h		Po03	*ODI2	MR-D01 input device selection 2 (CN10-27, 28)	0905h	
Po04	*ODI3	MR-J3-D01 input signal device selection 3 (CN10-29, 30)	2524h		Po04	*ODI3	MR-D01 input device selection 3 (CN10-29, 30)	2524h	
Po05	*ODI4	MR-J3-D01 input signal device selection 4 (CN10-31, 32)	2026h		Po05	*ODI4	MR-D01 input device selection 4 (CN10-31, 32)	2026h	
Po06	*ODI5	MR-J3-D01 input signal device selection 5 (CN10-33, 34)	0427h		Po06	*ODI5	MR-D01 input device selection 5 (CN10-33, 34)	0427h	
Po07	*ODI6	MR-J3-D01 input signal device selection 6 (CN10-35, 36)	0807h		Po07	*ODI6	MR-D01 input device selection 6 (CN10-35, 36)	0807h	
Po08	*ODO1	MR-J3-D01 output signal device selection 1 (CN10-46, 47)	2726h		Po08	*ODO1	MR-D01 output device selection 1 (CN10-46, 47)	2726h	
Po09	*ODO2	MR-J3-D01 output signal device selection 2 (CN10-48, 49)	0423h		Po09	*ODO2	MR-D01 output device selection 1 (CN10-48, 49)	0423h	
Po10	*OOP1	Function selection O-1	2101h		Po10	*OOP1	Function selection O-1	2101h	
Po12	*OOP3	Function selection O-3	0000h		Po12	*OOP3	Function selection O-3	0000h	
Po13	MOD1	MR-J3-D01 analog monitor output 1	0000h		Po13	*OMOD1	MR-D01 analog monitor 1 output selection	0000h	
Po14	MOD2	MR-J3-D01 analog monitor output 2	0001h		Po14	*OMOD2	MR-D01 analog monitor 2 output selection	0001h	
Po15	MO1	MR-J3-D01 analog monitor 1 offset	0		Po15	OMO1	MR-D01 analog monitor 1 offset	0	
Po16	MO2	MR-J3-D01 analog monitor 2 offset	0		Po16	OMO2	MR-D01 analog monitor 2 offset	0	
Po21	VCO	MR-J3-D01 override offset	0		Po21	OVCO	MR-D01 override offset	0	
Po22	TLO	MR-J3-D01 analog torque limit offset	0		Po22	OTLO	Analog torque limit offset	0	

3.6.3 Comparison of parameter details

POINT

● Setting a value out of the setting range in each parameter will trigger [AL. 37 Parameter error].

MR-J3-_T_			MR-J4-_A_-RJ		
No.	Name and function	Initial value	No.	Name and function	Initial value
PA01	Control mode This parameter is made valid when power is switched off, then on after setting, or when the controller reset has been performed. A HF-KP servo motor with a decelerator and servo motors except the HF-KP series do not support the 350 maximum torque setting. Making the 350 maximum torque setting valid when using these servo motors causes the [AL. 37 parameter error]. The maximum torque of the HF-KP series servo motors manufactured in June 2009 or later can be increased up to 350%. Making the 350% maximum torque setting valid when using these servo motors manufactured in May 2009 or earlier causes [AL. 37]. Select the 350% maximum torque setting and command system for the HF-KP series servo motor. By making the 350% maximum torque setting valid, the maximum torque of the HF-KP series servo motor can be increased from 300% to 350%. To operate at the maximum torque of 350%, operate within the range of overload protection characteristic. If operated beyond the overload protection characteristic range, [AL. 46 Servo motor overheat], [AL. 50 Overload 1] or [AL. 51 Overload 2] may occur.	0000h	PT01	Command mode selection ___x: Positioning command method selection 0: Absolute value command method 1: Incremental value command method	0h
	0_0x: Selection of command system 0: Absolute value command system 1: Incremental value command system			__x_: For manufacturer setting	0h
	0x0_: 350% maximum torque setting of HF-KP series servo motor 0: Disabled 3: Enabled This digit is available with servo amplifier with software version A8 or later.			_x_ _: Position data unit 0: mm	0h
				x_ _ _: RS-422 communication - Previous model equivalent selection 0: Disabled (MR-J4 standard) 1: Enabled (equivalent to MR-J3-T) For the communication command of the Mitsubishi general-purpose AC servo protocol, the status display and read/write commands of input/output devices can be used with the data Nos. and bit assignment of the same as previous models. When this digit is "1" or "2", MR Configurator2 cannot be used with the USB communication.	0h
			PA01	Operation mode ___x: Control mode selection Select a control mode. 0 to 5: Not used for positioning mode. 6: Positioning mode (point table method)	0h
				__x_: Operation mode selection 0: Standard control mode The following settings will trigger [AL. 37 Parameter error]. ▪ A value is set other than "0", "1", "4", and "6" to this digit. ▪ "1" or "4" is set to this digit when "Position data unit" is set to [degree] in [Pr. PT01].	0h
				x _: For manufacturer setting	0h
				x_ _ _: For manufacturer setting	1h

MR-J3-_T_			MR-J4-_A_-RJ				
No.	Name and function	Initial value	No.	Name and function	Initial value		
PA02	<p>Regenerative option</p> <p>This parameter is made valid when power is switched off, then on after setting.</p> <p>Wrong setting may cause the regenerative option to burn.</p> <p>If the regenerative option selected is not for use with the servo amplifier, [AL. 37 parameter error] occurs.</p> <p>Set this parameter when using the regenerative option, brake unit, power regeneration converter, or power regeneration common converter.</p> <p>0 0 x x:</p> <p>Selection of regenerative option</p> <p>00: Regenerative option is not used</p> <ul style="list-style-type: none"> • For the servo amplifiers of 100 W, a regenerative resistor is not used. • For servo amplifier of 0.2 kW to 7 kW, built-in regenerative resistor is used. • Supplied regenerative resistors or regenerative option is used with the servo amplifier of 11 kW to 22 kW. <p>01: FR-BU2-(H)/FR-RC-(H)/FR-CV-(H)</p> <p>02: MR-RB032</p> <p>03: MR-RB12</p> <p>04: MR-RB32</p> <p>05: MR-RB30</p> <p>06: MR-RB50 (Cooling fan is required)</p> <p>08: MR-RB31</p> <p>09: MR-RB51 (Cooling fan is required)</p> <p>80: MR-RB1H-4</p> <p>81: MR-RB3M-4 (Cooling fan is required)</p> <p>82: MR-RB3G-4 (Cooling fan is required)</p> <p>83: MR-RB5G-4 (Cooling fan is required)</p> <p>84: MR-RB34-4 (Cooling fan is required)</p> <p>85: MR-RB54-4 (Cooling fan is required)</p> <p>FA: When the supplied regenerative resistors or the regenerative option is cooled by the cooling fan to increase the ability with the servo amplifier of 11 kW to 22 kW.</p>	0000h	PA02	<p>Regenerative option</p> <p>Select a regenerative option.</p> <p>Incorrect setting may cause the regenerative option to burn.</p> <p>If a selected regenerative option is not for use with the servo amplifier, [AL. 37 Parameter error] occurs.</p> <p>00: Regenerative option is not used.</p> <ul style="list-style-type: none"> • For the servo amplifiers of 100 W, a regenerative resistor is not used. • For servo amplifier of 0.2 kW to 7 kW, built-in regenerative resistor is used. • Supplied regenerative resistors or regenerative option is used with the servo amplifier of 11 kW to 22 kW. <p>01: FR-RC-(H)/FR-CV-(H)/FR-BU2-(H)</p> <p>When you use FR-RC-(H) or FR-CV-(H), select "Mode 2 (_ _ _ 1)" of "Undervoltage alarm detection mode selection" in [Pr. PC27].</p> <p>02: MR-RB032</p> <p>03: MR-RB12</p> <p>04: MR-RB32</p> <p>05: MR-RB30</p> <p>06: MR-RB50 (Cooling fan is required.)</p> <p>08: MR-RB31</p> <p>09: MR-RB51 (Cooling fan is required.)</p> <p>0B: MR-RB3N</p> <p>0C: MR-RB5N (Cooling fan is required.)</p> <p>80: MR-RB1H-4</p> <p>81: MR-RB3M-4 (Cooling fan is required.)</p> <p>82: MR-RB3G-4 (Cooling fan is required.)</p> <p>83: MR-RB5G-4 (Cooling fan is required.)</p> <p>84: MR-RB34-4 (Cooling fan is required.)</p> <p>85: MR-RB54-4 (Cooling fan is required.)</p> <p>91: MR-RB3U-4 (Cooling fan is required.)</p> <p>92: MR-RB5U-4 (Cooling fan is required.)</p> <p>FA: When the supplied regenerative resistors or the regenerative option is cooled by the cooling fan to increase the ability with the servo amplifier of 11 kW to 22 kW.</p>	00h		
						_ x _ _:	0h
						For manufacturer setting	0h
PA03	<p>Absolute position detection system</p> <p>This parameter is made valid when power is switched off, then on after setting, or when the controller reset has been performed.</p> <p>Set this parameter when using the absolute position detection system.</p> <p>0 0 0 x:</p> <p>Selection of absolute position detection system</p> <p>0: Used in incremental system</p> <p>1: Used in absolute position detection system</p>	0000h	PA03	<p>Absolute position detection system</p> <p>_ _ _ x:</p> <p>Absolute position detection system selection</p> <p>Set this digit when using the absolute position detection system.</p> <p>0: Disabled (incremental system)</p> <p>1: Enabled (absolute position detection system)</p> <p>2: Not used for positioning mode.</p> <p>Setting a value other than "0" and "1" will trigger [AL. 37 Parameter error].</p>	0h		
						_ _ x _:	0h
						For manufacturer setting	0h
PA03	<p>Absolute position detection system</p> <p>This parameter is made valid when power is switched off, then on after setting, or when the controller reset has been performed.</p> <p>Set this parameter when using the absolute position detection system.</p> <p>0 0 0 x:</p> <p>Selection of absolute position detection system</p> <p>0: Used in incremental system</p> <p>1: Used in absolute position detection system</p>	0000h	PA03	<p>Absolute position detection system</p> <p>_ _ _ x:</p> <p>Absolute position detection system selection</p> <p>Set this digit when using the absolute position detection system.</p> <p>0: Disabled (incremental system)</p> <p>1: Enabled (absolute position detection system)</p> <p>2: Not used for positioning mode.</p> <p>Setting a value other than "0" and "1" will trigger [AL. 37 Parameter error].</p>	0h		
						_ x _ _:	0h
						For manufacturer setting	0h
PA03	<p>Absolute position detection system</p> <p>This parameter is made valid when power is switched off, then on after setting, or when the controller reset has been performed.</p> <p>Set this parameter when using the absolute position detection system.</p> <p>0 0 0 x:</p> <p>Selection of absolute position detection system</p> <p>0: Used in incremental system</p> <p>1: Used in absolute position detection system</p>	0000h	PA03	<p>Absolute position detection system</p> <p>x _ _ _:</p> <p>For manufacturer setting</p>	0h		
						For manufacturer setting	0h
						For manufacturer setting	0h

MR-J3-_T_			MR-J4-_A_-RJ																
No.	Name and function	Initial value	No.	Name and function	Initial value														
PA04	Function selection A-1 This parameter is made valid when power is switched off, then on after setting, or when the controller reset has been performed. If this parameter is made valid, the home position is not lost in the servo-off or forced stop state, and the operation can be resumed when the servo-on (SON) or forced stop (EMG) is deactivated.	0000h	PT02	Function selection T-1	0h														
	<p>0 0 0 x: Servo-on (SON) -off, forced stop (EMG) -off follow-up for absolute value command in incremental system 0: Disabled 1: Enabled</p> <p>Normally, when this servo amplifier is used in the absolute value command method of the incremental system, placing it in a servo off or forced stop status will erase the home position. When "1" is set in this parameter, the home position will not be erased if the servo amplifier is placed in a servo-off or forced stop status. The operation can be resumed when the servo-on (SON) or forced stop (EMG) is deactivated.</p>			<p>___ x: Follow-up of SON (Servo-on) off/EM2 (Forced stop 2) off with absolute value command method in incremental system 0: Disabled (Home position is erased at servo-off or EM2 off.) 1: Enabled (Home position is not erased even if servo-off, EM2 off, or alarm occurrence which can be canceled with reset. The operation can be continued.)</p>															
PA04			PA04	Function selection A-1	0h														
				<p>___ x: For manufacturer setting</p> <p>__ x _: For manufacturer setting</p> <p>_ x __: For manufacturer setting</p> <p>x ___: Forced stop deceleration function selection 0: Forced stop deceleration function disabled (EM1) 2: Forced stop deceleration function enabled (EM2) Refer to table 6.1 for details.</p>															
Table 6.1 Deceleration method																			
<table border="1" style="width: 100%; border-collapse: collapse;"> <thead> <tr> <th rowspan="2">Setting value</th> <th rowspan="2">EM2/EM1</th> <th colspan="2">Deceleration method</th> </tr> <tr> <th>EM2 or EM1 is off</th> <th>Alarm occurred</th> </tr> </thead> <tbody> <tr> <td>0 ___</td> <td>EM1</td> <td>MBR (Electromagnetic brake interlock) turns off without the forced stop deceleration.</td> <td>MBR (Electromagnetic brake interlock) turns off without the forced stop deceleration.</td> </tr> <tr> <td>2 ___</td> <td>EM2</td> <td>MBR (Electromagnetic brake interlock) turns off after the forced stop deceleration.</td> <td>MBR (Electromagnetic brake interlock) turns off after the forced stop deceleration.</td> </tr> </tbody> </table>						Setting value	EM2/EM1	Deceleration method		EM2 or EM1 is off	Alarm occurred	0 ___	EM1	MBR (Electromagnetic brake interlock) turns off without the forced stop deceleration.	MBR (Electromagnetic brake interlock) turns off without the forced stop deceleration.	2 ___	EM2	MBR (Electromagnetic brake interlock) turns off after the forced stop deceleration.	MBR (Electromagnetic brake interlock) turns off after the forced stop deceleration.
Setting value	EM2/EM1	Deceleration method																	
		EM2 or EM1 is off	Alarm occurred																
0 ___	EM1	MBR (Electromagnetic brake interlock) turns off without the forced stop deceleration.	MBR (Electromagnetic brake interlock) turns off without the forced stop deceleration.																
2 ___	EM2	MBR (Electromagnetic brake interlock) turns off after the forced stop deceleration.	MBR (Electromagnetic brake interlock) turns off after the forced stop deceleration.																

MR-J3-_T_			MR-J4-_A_-RJ																													
No.	Name and function	Initial value	No.	Name and function	Initial value																											
PA05	Feeding function selection This parameter is made valid when power is switched off, then on after setting, or when the controller reset has been performed. Select the feed length multiplication and the manual pulse generator input multiplication.	0000h	PT03	Feeding function selection	0h																											
	0 __ x:			___ x: Feed length multiplication [STM] 0: × 1 1: × 10 2: × 100 3: × 1000																												
	<table border="1"> <thead> <tr> <th rowspan="2">Setting value</th> <th rowspan="2">Feed length multiplication factor (STM) [times]</th> <th rowspan="2">Feed unit [m]</th> <th colspan="2">Position data input range [mm]</th> </tr> <tr> <th>Absolute value command system</th> <th>Incremental value command system</th> </tr> </thead> <tbody> <tr> <td>0</td> <td>1</td> <td>1</td> <td>-999.999 to +999.999</td> <td>0 to +999.999</td> </tr> <tr> <td>1</td> <td>10</td> <td>10</td> <td>-9999.99 to +9999.99</td> <td>0 to +9999.99</td> </tr> <tr> <td>2</td> <td>100</td> <td>100</td> <td>-99999.9 to +99999.9</td> <td>0 to +99999.9</td> </tr> <tr> <td>3</td> <td>1000</td> <td>1000</td> <td>-999999 to +999999</td> <td>0 to +999999</td> </tr> </tbody> </table>			Setting value		Feed length multiplication factor (STM) [times]	Feed unit [m]	Position data input range [mm]		Absolute value command system	Incremental value command system	0	1	1	-999.999 to +999.999	0 to +999.999	1	10	10	-9999.99 to +9999.99	0 to +9999.99	2	100	100	-99999.9 to +99999.9	0 to +99999.9	3	1000	1000	-999999 to +999999	0 to +999999	__ x _: Manual pulse generator multiplication 0: × 1 1: × 10 2: × 100
	Setting value							Feed length multiplication factor (STM) [times]	Feed unit [m]	Position data input range [mm]																						
Absolute value command system		Incremental value command system																														
0	1	1	-999.999 to +999.999	0 to +999.999																												
1	10	10	-9999.99 to +9999.99	0 to +9999.99																												
2	100	100	-99999.9 to +99999.9	0 to +99999.9																												
3	1000	1000	-999999 to +999999	0 to +999999																												
0 x _:	Manual pulse generator multiplication factor 0: 1 time 1: 10 times 2: 100 times	_ x _: For manufacturer setting	x _ _: For manufacturer setting																													
	0 x _: Servo motor speed setting unit selection 0: 1 r/min unit 1: 0.1 r/min unit Setting "1" will display "servo motor speed" in units of 0.1 r/min. This digit is available with servo amplifier with software version A4 or later.		PC29	Function selection C-8																												
				___ x: For manufacturer setting	0h																											
				__ x _: Speed command input unit selection Select the setting units of [Pr. PC05] to [Pr. PC11], [Pr. PT05], [Pr. PT06], and [Pr. PT13]. 0: 1 r/min Unit 1: 0.1 r/min Unit Setting "1" will display "servo motor speed" in units of 0.1 r/min. When displaying data recorded with the drive recorder function, do not change this digit before and after the recording. Doing so will display the data incorrectly because the setting unit differs between when the data was recorded and when the recorded data is displayed. This digit is available with servo amplifier with software version B3 or later.	0h																											
				_ x _: For manufacturer setting	0h																											
				x _ _: For manufacturer setting	0h																											

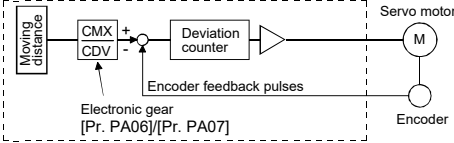
MR-J3-_T_			MR-J4-_A_-RJ										
No.	Name and function	Initial value	No.	Name and function	Initial value								
PA06 PA07	<p>Electronic gear numerator (command pulse multiplication numerator)</p> <p>Electronic gear denominator (command pulse multiplication denominator)</p> <div style="border: 1px solid black; padding: 5px; margin: 10px 0;"> <p>CAUTION ● False setting will result in unexpected fast rotation, causing injury.</p> </div> <p>This parameter is made valid when power is switched off, then on after setting, or when the controller reset has been performed.</p> <p>The range of the electronic gear setting is $\frac{1}{10} < \frac{CMX}{CDV} < 2000$. If you set any value outside this range, [AL. 37 parameter error] occurs.</p> <p>Setting "0" in [Pr. PA06] automatically sets the encoder resolution pulse.</p> <p>(1) Concept of electronic gear</p> <p>Use the electronic gear ([Pr. PA06]/[Pr. PA07]) to make adjustment so that the servo amplifier setting matches the moving distance of the machine. Also, by changing the electronic gear value, the machine can be moved at any multiplication ratio to the moving distance on the servo amplifier.</p> $\frac{CMX}{CDV} = \frac{[Pr. PA06]}{[Pr. PA07]}$ 	1 1	PA06	<p>Electronic gear numerator (command pulse multiplication numerator)</p> <p>Set an electronic gear numerator.</p> <p>To enable the parameter values in the positioning mode, cycle the power after setting.</p> <p>To enable the parameter, select "Electronic gear (0 ___)", "J3 electronic gear setting value compatibility mode (2 ___)", or "J2S electronic gear setting value compatibility mode (3 ___)" of "Electronic gear selection" in [Pr. PA21].</p> <p>Set the electronic gear within the following range. Setting out of the range will trigger [AL. 37 Parameter error].</p> <table border="1" style="margin: 10px auto;"> <thead> <tr> <th>Pr. PA21</th> <th>Electronic gear setting range</th> </tr> </thead> <tbody> <tr> <td>0 ___</td> <td>1/865 < CMX/CDV < 271471</td> </tr> <tr> <td>2 ___</td> <td>1/13825 < CMX/CDV < 16967</td> </tr> <tr> <td>3 ___</td> <td>1/27649 < CMX/CDV < 8484</td> </tr> </tbody> </table> <p>Setting range: 1 to 16777215</p>	Pr. PA21	Electronic gear setting range	0 ___	1/865 < CMX/CDV < 271471	2 ___	1/13825 < CMX/CDV < 16967	3 ___	1/27649 < CMX/CDV < 8484	1
Pr. PA21	Electronic gear setting range												
0 ___	1/865 < CMX/CDV < 271471												
2 ___	1/13825 < CMX/CDV < 16967												
3 ___	1/27649 < CMX/CDV < 8484												
			PA07	<p>Electronic gear denominator (command pulse multiplication denominator)</p> <p>Set an electronic gear denominator.</p> <p>To enable the parameter values in the positioning mode, cycle the power after setting.</p> <p>To enable the parameter, select "Electronic gear (0 ___)", "J3 electronic gear setting value compatibility mode (2 ___)", or "J2S electronic gear setting value compatibility mode (3 ___)" of "Electronic gear selection" in [Pr. PA21].</p> <p>Set the electronic gear within the range of [Pr. PA06].</p> <p>Setting out of the range will trigger [AL. 37 Parameter error].</p> <p>Setting range: 1 to 16777215</p>	1								

MR-J3-_T_			MR-J4-_A_-RJ																																																																																																																																																																				
No.	Name and function	Initial value	No.	Name and function	Initial value																																																																																																																																																																		
PA08	Auto tuning mode Make gain adjustment using auto tuning.	0001h	PA08	Auto tuning mode	1h																																																																																																																																																																		
	Select the gain adjustment mode. 0 0 0 x: Gain adjustment mode setting 0: Interpolation mode (Automatically set parameter No. [Pr. PB06]/[Pr. PB08]/[Pr. PB09]/[Pr. PB10]) 1: Auto tuning mode 1 (Automatically set parameter No. [Pr. PB06]/[Pr. PB07]/[Pr. PB08]/[Pr. PB09]/[Pr. PB10]) 2: Auto tuning mode 2 (Automatically set parameter No. [Pr. PB07]/[Pr. PB08]/[Pr. PB09]/[Pr. PB10]) The parameters have the following names.			___ x: Gain adjustment mode selection Select the gain adjustment mode. 0: 2 gain adjustment mode 1 (interpolation mode) 1: Auto tuning mode 1 2: Auto tuning mode 2 3: Manual mode 4: 2 gain adjustment mode 2 Refer to table 6.2 for details. __ x _: For manufacturer setting _ x _ _: For manufacturer setting x _ _ _: For manufacturer setting																																																																																																																																																																			
	<table border="1"> <thead> <tr> <th>No.</th> <th>Name</th> </tr> </thead> <tbody> <tr> <td>PB06</td> <td>Ratio of load inertia moment to servo motor inertia moment</td> </tr> <tr> <td>PB07</td> <td>Model loop gain</td> </tr> <tr> <td>PB08</td> <td>Position loop gain</td> </tr> <tr> <td>PB09</td> <td>Speed loop gain</td> </tr> <tr> <td>PB10</td> <td>Speed integral compensation</td> </tr> </tbody> </table>	No.	Name	PB06	Ratio of load inertia moment to servo motor inertia moment	PB07	Model loop gain	PB08	Position loop gain	PB09	Speed loop gain	PB10	Speed integral compensation		<p>Table 6.2 Gain adjustment mode selection</p> <table border="1"> <thead> <tr> <th>Setting value</th> <th>Gain adjustment mode</th> <th>Automatically adjusted parameter</th> </tr> </thead> <tbody> <tr> <td rowspan="4">___ 0</td> <td rowspan="4">2 gain adjustment mode 1 (interpolation mode)</td> <td>[Pr. PB06 Load to motor inertia ratio]</td> </tr> <tr> <td>[Pr. PB08 Position loop gain]</td> </tr> <tr> <td>[Pr. PB09 Speed loop gain]</td> </tr> <tr> <td>[Pr. PB10 Speed integral compensation]</td> </tr> <tr> <td rowspan="4">___ 1</td> <td rowspan="4">Auto tuning mode 1</td> <td>[Pr. PB06 Load to motor inertia ratio]</td> </tr> <tr> <td>[Pr. PB07 Model loop gain]</td> </tr> <tr> <td>[Pr. PB08 Position loop gain]</td> </tr> <tr> <td>[Pr. PB09 Speed loop gain]</td> </tr> <tr> <td rowspan="4">___ 2</td> <td rowspan="4">Auto tuning mode 2</td> <td>[Pr. PB07 Model loop gain]</td> </tr> <tr> <td>[Pr. PB08 Position loop gain]</td> </tr> <tr> <td>[Pr. PB09 Speed loop gain]</td> </tr> <tr> <td>[Pr. PB10 Speed integral compensation]</td> </tr> <tr> <td>___ 3</td> <td>Manual mode</td> <td></td> </tr> <tr> <td rowspan="3">___ 4</td> <td rowspan="3">2 gain adjustment mode 2</td> <td>[Pr. PB08 Position loop gain]</td> </tr> <tr> <td>[Pr. PB09 Speed loop gain]</td> </tr> <tr> <td>[Pr. PB10 Speed integral compensation]</td> </tr> </tbody> </table>			Setting value	Gain adjustment mode	Automatically adjusted parameter	___ 0	2 gain adjustment mode 1 (interpolation mode)	[Pr. PB06 Load to motor inertia ratio]	[Pr. PB08 Position loop gain]	[Pr. PB09 Speed loop gain]	[Pr. PB10 Speed integral compensation]	___ 1	Auto tuning mode 1	[Pr. PB06 Load to motor inertia ratio]	[Pr. PB07 Model loop gain]	[Pr. PB08 Position loop gain]	[Pr. PB09 Speed loop gain]	___ 2	Auto tuning mode 2	[Pr. PB07 Model loop gain]	[Pr. PB08 Position loop gain]	[Pr. PB09 Speed loop gain]	[Pr. PB10 Speed integral compensation]	___ 3	Manual mode		___ 4	2 gain adjustment mode 2	[Pr. PB08 Position loop gain]	[Pr. PB09 Speed loop gain]	[Pr. PB10 Speed integral compensation]																																																																																																																									
No.	Name																																																																																																																																																																						
PB06	Ratio of load inertia moment to servo motor inertia moment																																																																																																																																																																						
PB07	Model loop gain																																																																																																																																																																						
PB08	Position loop gain																																																																																																																																																																						
PB09	Speed loop gain																																																																																																																																																																						
PB10	Speed integral compensation																																																																																																																																																																						
Setting value	Gain adjustment mode	Automatically adjusted parameter																																																																																																																																																																					
___ 0	2 gain adjustment mode 1 (interpolation mode)	[Pr. PB06 Load to motor inertia ratio]																																																																																																																																																																					
		[Pr. PB08 Position loop gain]																																																																																																																																																																					
		[Pr. PB09 Speed loop gain]																																																																																																																																																																					
		[Pr. PB10 Speed integral compensation]																																																																																																																																																																					
___ 1	Auto tuning mode 1	[Pr. PB06 Load to motor inertia ratio]																																																																																																																																																																					
		[Pr. PB07 Model loop gain]																																																																																																																																																																					
		[Pr. PB08 Position loop gain]																																																																																																																																																																					
		[Pr. PB09 Speed loop gain]																																																																																																																																																																					
___ 2	Auto tuning mode 2	[Pr. PB07 Model loop gain]																																																																																																																																																																					
		[Pr. PB08 Position loop gain]																																																																																																																																																																					
		[Pr. PB09 Speed loop gain]																																																																																																																																																																					
		[Pr. PB10 Speed integral compensation]																																																																																																																																																																					
___ 3	Manual mode																																																																																																																																																																						
___ 4	2 gain adjustment mode 2	[Pr. PB08 Position loop gain]																																																																																																																																																																					
		[Pr. PB09 Speed loop gain]																																																																																																																																																																					
		[Pr. PB10 Speed integral compensation]																																																																																																																																																																					
PA09	Auto tuning response If the machine hunts or generates large gear sound, decrease the set value. To improve performance, e.g. shorten the settling time, increase the set value.	12	PA09	Auto tuning response Set the auto tuning response.	16																																																																																																																																																																		
	<table border="1"> <thead> <tr> <th>Setting</th> <th>Response</th> <th>Guideline for machine resonance frequency [Hz]</th> </tr> </thead> <tbody> <tr><td>1</td><td rowspan="15">↑ Low response</td><td>10.0</td></tr> <tr><td>2</td><td>11.3</td></tr> <tr><td>3</td><td>12.7</td></tr> <tr><td>4</td><td>14.3</td></tr> <tr><td>5</td><td>16.1</td></tr> <tr><td>6</td><td>18.1</td></tr> <tr><td>7</td><td>20.4</td></tr> <tr><td>8</td><td>23.0</td></tr> <tr><td>9</td><td>25.9</td></tr> <tr><td>10</td><td>29.2</td></tr> <tr><td>11</td><td>32.9</td></tr> <tr><td>12</td><td>37.0</td></tr> <tr><td>13</td><td>41.7</td></tr> <tr><td>14</td><td>47.0</td></tr> <tr><td>15</td><td>52.9</td></tr> <tr><td>16</td><td>Middle response</td><td>59.6</td></tr> </tbody> </table> <table border="1"> <thead> <tr> <th>Setting</th> <th>Response</th> <th>Guideline for machine resonance frequency [Hz]</th> </tr> </thead> <tbody> <tr><td>17</td><td rowspan="15">↑ Middle response</td><td>67.1</td></tr> <tr><td>18</td><td>75.6</td></tr> <tr><td>19</td><td>85.2</td></tr> <tr><td>20</td><td>95.9</td></tr> <tr><td>21</td><td>108.0</td></tr> <tr><td>22</td><td>121.7</td></tr> <tr><td>23</td><td>137.1</td></tr> <tr><td>24</td><td>154.4</td></tr> <tr><td>25</td><td>173.9</td></tr> <tr><td>26</td><td>195.9</td></tr> <tr><td>27</td><td>220.6</td></tr> <tr><td>28</td><td>248.5</td></tr> <tr><td>29</td><td>279.9</td></tr> <tr><td>30</td><td>315.3</td></tr> <tr><td>31</td><td>355.1</td></tr> <tr><td>32</td><td>High response</td><td>400.0</td></tr> </tbody> </table>	Setting	Response	Guideline for machine resonance frequency [Hz]	1	↑ Low response	10.0	2	11.3	3	12.7	4	14.3	5	16.1	6	18.1	7	20.4	8	23.0	9	25.9	10	29.2	11	32.9	12	37.0	13	41.7	14	47.0	15	52.9	16	Middle response	59.6	Setting	Response	Guideline for machine resonance frequency [Hz]	17	↑ Middle response	67.1	18	75.6	19	85.2	20	95.9	21	108.0	22	121.7	23	137.1	24	154.4	25	173.9	26	195.9	27	220.6	28	248.5	29	279.9	30	315.3	31	355.1	32	High response	400.0		<table border="1"> <thead> <tr> <th>Setting value</th> <th>Response</th> <th>Guideline for machine resonance frequency [Hz]</th> </tr> </thead> <tbody> <tr><td>1</td><td rowspan="19">↑ Low response</td><td>2.7</td></tr> <tr><td>2</td><td>3.6</td></tr> <tr><td>3</td><td>4.9</td></tr> <tr><td>4</td><td>6.6</td></tr> <tr><td>5</td><td>10.0</td></tr> <tr><td>6</td><td>11.3</td></tr> <tr><td>7</td><td>12.7</td></tr> <tr><td>8</td><td>14.3</td></tr> <tr><td>9</td><td>16.1</td></tr> <tr><td>10</td><td>18.1</td></tr> <tr><td>11</td><td>20.4</td></tr> <tr><td>12</td><td>23.0</td></tr> <tr><td>13</td><td>25.9</td></tr> <tr><td>14</td><td>29.2</td></tr> <tr><td>15</td><td>32.9</td></tr> <tr><td>16</td><td>37.0</td></tr> <tr><td>17</td><td>41.7</td></tr> <tr><td>18</td><td>47.0</td></tr> <tr><td>19</td><td>52.9</td></tr> <tr><td>20</td><td>Middle response</td><td>59.6</td></tr> <tr> <th>Setting value</th> <th>Response</th> <th>Guideline for machine resonance frequency [Hz]</th> </tr> <tr><td>21</td><td rowspan="20">↑ Middle response</td><td>67.1</td></tr> <tr><td>22</td><td>75.6</td></tr> <tr><td>23</td><td>85.2</td></tr> <tr><td>24</td><td>95.9</td></tr> <tr><td>25</td><td>108.0</td></tr> <tr><td>26</td><td>121.7</td></tr> <tr><td>27</td><td>137.1</td></tr> <tr><td>28</td><td>154.4</td></tr> <tr><td>29</td><td>173.9</td></tr> <tr><td>30</td><td>195.9</td></tr> <tr><td>31</td><td>220.6</td></tr> <tr><td>32</td><td>248.5</td></tr> <tr><td>33</td><td>279.9</td></tr> <tr><td>34</td><td>315.3</td></tr> <tr><td>35</td><td>355.1</td></tr> <tr><td>36</td><td>400.0</td></tr> <tr><td>37</td><td>446.6</td></tr> <tr><td>38</td><td>501.2</td></tr> <tr><td>39</td><td>571.5</td></tr> <tr><td>40</td><td>High response</td><td>642.7</td></tr> </tbody> </table> <p>Setting range: 1 to 40</p>	Setting value	Response	Guideline for machine resonance frequency [Hz]	1	↑ Low response	2.7	2	3.6	3	4.9	4	6.6	5	10.0	6	11.3	7	12.7	8	14.3	9	16.1	10	18.1	11	20.4	12	23.0	13	25.9	14	29.2	15	32.9	16	37.0	17	41.7	18	47.0	19	52.9	20	Middle response	59.6	Setting value	Response	Guideline for machine resonance frequency [Hz]	21	↑ Middle response	67.1	22	75.6	23	85.2	24	95.9	25	108.0	26	121.7	27	137.1	28	154.4	29	173.9	30	195.9	31	220.6	32	248.5	33	279.9	34	315.3	35	355.1	36	400.0	37	446.6	38	501.2	39	571.5	40	High response	642.7
Setting	Response	Guideline for machine resonance frequency [Hz]																																																																																																																																																																					
1	↑ Low response	10.0																																																																																																																																																																					
2		11.3																																																																																																																																																																					
3		12.7																																																																																																																																																																					
4		14.3																																																																																																																																																																					
5		16.1																																																																																																																																																																					
6		18.1																																																																																																																																																																					
7		20.4																																																																																																																																																																					
8		23.0																																																																																																																																																																					
9		25.9																																																																																																																																																																					
10		29.2																																																																																																																																																																					
11		32.9																																																																																																																																																																					
12		37.0																																																																																																																																																																					
13		41.7																																																																																																																																																																					
14		47.0																																																																																																																																																																					
15		52.9																																																																																																																																																																					
16	Middle response	59.6																																																																																																																																																																					
Setting	Response	Guideline for machine resonance frequency [Hz]																																																																																																																																																																					
17	↑ Middle response	67.1																																																																																																																																																																					
18		75.6																																																																																																																																																																					
19		85.2																																																																																																																																																																					
20		95.9																																																																																																																																																																					
21		108.0																																																																																																																																																																					
22		121.7																																																																																																																																																																					
23		137.1																																																																																																																																																																					
24		154.4																																																																																																																																																																					
25		173.9																																																																																																																																																																					
26		195.9																																																																																																																																																																					
27		220.6																																																																																																																																																																					
28		248.5																																																																																																																																																																					
29		279.9																																																																																																																																																																					
30		315.3																																																																																																																																																																					
31		355.1																																																																																																																																																																					
32	High response	400.0																																																																																																																																																																					
Setting value	Response	Guideline for machine resonance frequency [Hz]																																																																																																																																																																					
1	↑ Low response	2.7																																																																																																																																																																					
2		3.6																																																																																																																																																																					
3		4.9																																																																																																																																																																					
4		6.6																																																																																																																																																																					
5		10.0																																																																																																																																																																					
6		11.3																																																																																																																																																																					
7		12.7																																																																																																																																																																					
8		14.3																																																																																																																																																																					
9		16.1																																																																																																																																																																					
10		18.1																																																																																																																																																																					
11		20.4																																																																																																																																																																					
12		23.0																																																																																																																																																																					
13		25.9																																																																																																																																																																					
14		29.2																																																																																																																																																																					
15		32.9																																																																																																																																																																					
16		37.0																																																																																																																																																																					
17		41.7																																																																																																																																																																					
18		47.0																																																																																																																																																																					
19		52.9																																																																																																																																																																					
20	Middle response	59.6																																																																																																																																																																					
Setting value	Response	Guideline for machine resonance frequency [Hz]																																																																																																																																																																					
21	↑ Middle response	67.1																																																																																																																																																																					
22		75.6																																																																																																																																																																					
23		85.2																																																																																																																																																																					
24		95.9																																																																																																																																																																					
25		108.0																																																																																																																																																																					
26		121.7																																																																																																																																																																					
27		137.1																																																																																																																																																																					
28		154.4																																																																																																																																																																					
29		173.9																																																																																																																																																																					
30		195.9																																																																																																																																																																					
31		220.6																																																																																																																																																																					
32		248.5																																																																																																																																																																					
33		279.9																																																																																																																																																																					
34		315.3																																																																																																																																																																					
35		355.1																																																																																																																																																																					
36		400.0																																																																																																																																																																					
37		446.6																																																																																																																																																																					
38		501.2																																																																																																																																																																					
39		571.5																																																																																																																																																																					
40		High response	642.7																																																																																																																																																																				

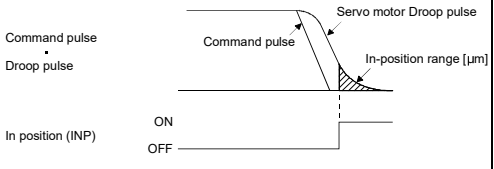
MR-J3-_T_			MR-J4-_A_-RJ						
No.	Name and function	Initial value	No.	Name and function	Initial value				
PA10	<p>In-position range</p> <p>Set the range, where In position (INP) and Movement finish (MEND) are output, in the command pulse unit before calculation of the electronic gear. With the setting of [Pr. PC24], the range can be changed to the encoder output pulse unit.</p> 	100	PA10	<p>INP In-position range</p> <p>Set an in-position range per command.</p> <p>To change it to the servo motor encoder pulse unit, set [Pr. PC24].</p> <table border="1" data-bbox="877 425 1348 571"> <tr> <td>Pr. PA01</td> <td>In-position setting range</td> </tr> <tr> <td>___ 6 (positioning mode (point table method))</td> <td>The range where MEND (Travel completion), PED (Position end) and INP (In-position) are inputted.</td> </tr> </table> <p>The unit will be as follows depending on the positioning mode.</p> <ul style="list-style-type: none"> Point table method <ul style="list-style-type: none"> When [Pr. PC24] is set to "___ 0", the unit can be changed to [µm], 10-4 [inch], 10-3 [degree], or [pulse] with the setting of [Pr. PT01]. When [Pr. PC24] is set to "___ 1", the unit is fixed to [pulse]. <p>Setting range: 0 to 65535</p>	Pr. PA01	In-position setting range	___ 6 (positioning mode (point table method))	The range where MEND (Travel completion), PED (Position end) and INP (In-position) are inputted.	100
Pr. PA01	In-position setting range								
___ 6 (positioning mode (point table method))	The range where MEND (Travel completion), PED (Position end) and INP (In-position) are inputted.								
PA11	<p>Forward rotation torque limit</p>	100.0	PA11	<p>Forward rotation torque limit</p> <p>You can limit the torque generated by the servo motor. Set the parameter referring to section 3.6.1 (5) of "MR-J4-_A_-RJ)/MR-J4-03A6(-RJ) Servo Amplifier Instruction Manual".</p> <p>When you output torque with analog monitor output, the larger value of [Pr. PA11 Forward rotation torque limit] or [Pr. PA12 Reverse rotation torque limit] will be the maximum output voltage (8 V).</p> <p>Set the parameter on the assumption that the maximum torque is 100.0 [%]. The parameter is for limiting the torque of the servo motor in the CCW power running or CW regeneration. Set this parameter to "0.0" to generate no torque.</p> <p>Setting range: 0.0 to 100.0</p>	100.0				
PA12	<p>Reverse rotation torque limit</p> <p>The torque generated by the servo motor can be limited. When torque is output with the analog monitor output, the smaller torque of the values in the [Pr. PA11] (forward rotation torque limit) and [Pr. PA12] (reverse rotation torque limit) is the maximum output voltage (8V).</p> <p>Forward rotation torque limit [Pr. PA11]</p> <p>Set this parameter on the assumption that the maximum torque is 100[%]. Set this parameter when limiting the torque of the servo motor in the CCW driving mode or CW regeneration mode. Set this parameter to "0.0" to generate no torque.</p> <p>Reverse rotation torque limit [Pr. PA12]</p> <p>Set this parameter on the assumption that the maximum torque is 100[%]. Set this parameter when limiting the torque of the servo motor in the CW driving mode or CCW regeneration mode. Set this parameter to "0.0" to generate no torque.</p>	100.0	PA12	<p>Reverse rotation torque limit</p> <p>You can limit the torque generated by the servo motor. Set the parameter referring to section 3.6.1 (5) of "MR-J4-_A_-RJ)/MR-J4-03A6(-RJ) Servo Amplifier Instruction Manual".</p> <p>When you output torque with analog monitor output, the larger value of [Pr. PA11 Forward rotation torque limit] or [Pr. PA12 Reverse rotation torque limit] will be the maximum output voltage (8 V).</p> <p>Set the parameter on the assumption that the maximum torque is 100.0 [%].The parameter is for limiting the torque of the servo motor in the CW power running or CCW regeneration. Set this parameter to "0.0" to generate no torque.</p> <p>Setting range: 0.0 to 100.0</p>	100.0				

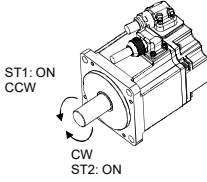
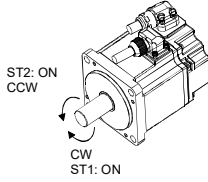
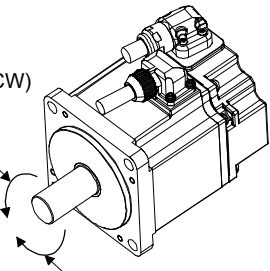
MR-J3-_T_			MR-J4-_A_-RJ																									
No.	Name and function	Initial value	No.	Name and function	Initial value																							
PA14	<p>Rotation direction selection</p> <p>This parameter is made valid when power is switched off, then on after setting, or when the controller reset has been performed.</p> <p>Select the servo motor rotation direction when the forward rotation start (ST1) or reverse rotation direction (ST2) is turned ON.</p> <table border="1" data-bbox="236 539 708 741"> <thead> <tr> <th>[Pr. PA14] Setting</th> <th colspan="2">Servo motor rotation direction</th> </tr> <tr> <td></td> <th>Forward rotation start (ST1) ON</th> <th>Reverse rotation start (ST2) ON</th> </tr> </thead> <tbody> <tr> <td>0</td> <td>Rotates in the CCW direction. (Address increases.)</td> <td>Rotates in the CW direction. (Address decreases.)</td> </tr> <tr> <td>1</td> <td>Rotates in the CW direction. (Address increases.)</td> <td>Rotates in the CCW direction. (Address decreases.)</td> </tr> </tbody> </table> <div style="display: flex; justify-content: space-around; margin-top: 10px;"> <div style="text-align: center;">  <p>ST1: ON CCW</p> <p>CW ST2: ON</p> <p>[Pr. PA14]: 0</p> </div> <div style="text-align: center;">  <p>ST2: ON CCW</p> <p>CW ST1: ON</p> <p>[Pr. PA14]: 1</p> </div> </div>	[Pr. PA14] Setting	Servo motor rotation direction			Forward rotation start (ST1) ON	Reverse rotation start (ST2) ON	0	Rotates in the CCW direction. (Address increases.)	Rotates in the CW direction. (Address decreases.)	1	Rotates in the CW direction. (Address increases.)	Rotates in the CCW direction. (Address decreases.)	0	PA14	<p>Rotation direction selection</p> <p>Select a rotation direction of the servo motor for when turning on ST1 (Forward rotation start) or ST2 (Reverse rotation start).</p> <table border="1" data-bbox="885 456 1353 629"> <thead> <tr> <th rowspan="2">Setting value</th> <th colspan="2">Servo motor rotation direction</th> </tr> <tr> <th>When positioning address increases</th> <th>When positioning address decreases</th> </tr> </thead> <tbody> <tr> <td>0</td> <td>CCW</td> <td>CW</td> </tr> <tr> <td>1</td> <td>CW</td> <td>CCW</td> </tr> </tbody> </table> <p>The following shows the servo motor rotation directions.</p> <div style="text-align: center; margin-top: 10px;">  <p>Forward rotation (CCW)</p> <p>Reverse rotation (CW)</p> </div> <p>Setting range: 0,1</p>	Setting value	Servo motor rotation direction		When positioning address increases	When positioning address decreases	0	CCW	CW	1	CW	CCW	0
[Pr. PA14] Setting	Servo motor rotation direction																											
	Forward rotation start (ST1) ON	Reverse rotation start (ST2) ON																										
0	Rotates in the CCW direction. (Address increases.)	Rotates in the CW direction. (Address decreases.)																										
1	Rotates in the CW direction. (Address increases.)	Rotates in the CCW direction. (Address decreases.)																										
Setting value	Servo motor rotation direction																											
	When positioning address increases	When positioning address decreases																										
0	CCW	CW																										
1	CW	CCW																										

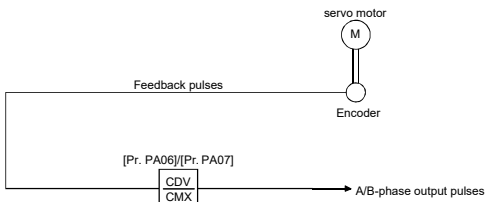
MR-J3-_T_			MR-J4-_A_-RJ		
No.	Name and function	Initial value	No.	Name and function	Initial value
PA15	<p>Encoder output pulse</p> <p>This parameter is made valid when power is switched off, then on after setting, or when the controller reset has been performed.</p> <p>Used to set the encoder pulses (A-phase, B-phase) output by the servo amplifier.</p> <p>Set the value 4 times greater than the A-phase or B-phase pulses.</p> <p>You can use [Pr. PC19] to choose the output pulse setting or output division ratio setting.</p> <p>The number of A/B-phase pulses actually output is 1/4 times greater than the preset number of pulses.</p> <p>The maximum output frequency is 4.6Mpps (after multiplication by 4). Use this parameter within this range.</p> <p>(1) For output pulse designation Set " __ 0 _ " (initial value) in [Pr. PC19]. Set the number of pulses per servo motor revolution. Output pulse = set value [pulses/rev] For instance, set "5600" to [Pr. PA15] PA15, the actually output A/B-phase pulses are as indicated below.</p> $\text{A/B-phase output pulses} = \frac{5600}{1} = 1400 \text{ pulses}$ <p>(2) For output division ratio setting Set " __ 1 _ " in [Pr. PC19]. The number of pulses per servo motor revolution is divided by the set value.</p> $\text{Output pulse} = \frac{\text{Resolution per servo motor revolution}}{\text{Set value}} = [\text{pulse/rev}]$ <p>For instance, set "8" to [Pr. PA15], the actually output A/B-phase pulses are as indicated below.</p> $\text{A/B-phase output pulses} = \frac{262144}{8} \cdot \frac{1}{4} = 8192 \text{ pulses}$ <p>(3) When outputting pulse train similar to command pulses [Pr. PC19] to " __ 2 _ ". The feedback pulses from the servo motor encoder are processed and output as shown below. The feedback pulses can be output in the same pulse unit as the command pulses.</p> 	4000	PA15	<p>Encoder output pulses</p> <p>Set the encoder output pulses from the servo amplifier by using the number of output pulses per revolution, dividing ratio, or electronic gear ratio. (after multiplication by 4).</p> <p>Set a numerator of the electronic gear, for when selecting "A-phase/B-phase pulse electronic gear setting (__ 3 _)" of "Encoder output pulse setting selection" in [Pr. PC19].</p> <p>The maximum output frequency is 4.6 Mpulses/s. Set the parameter within this range.</p> <p>Setting range: 1 to 4194304</p>	4000

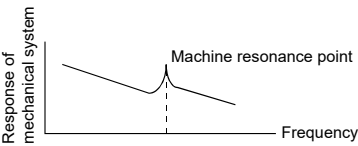
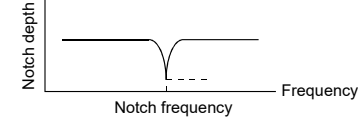
MR-J3-_T_			MR-J4-_A_-RJ																																																																																																																																																																																																																																																																																																																				
No.	Name and function	Initial value	No.	Name and function	Initial value																																																																																																																																																																																																																																																																																																																		
PA19	<p>Parameter write inhibit</p> <p>This parameter is made valid when power is switched off, then on after setting, or when the controller reset has been performed.</p> <p>In the factory setting, this servo amplifier allows changes to the basic setting parameter, gain/filter parameter and extension setting parameter settings. With the setting of [Pr. PA19], write can be disabled to prevent accidental changes.</p> <p>The following table indicates the parameters which are enabled for reference and write by the setting of [Pr. PA19]. Operation can be performed for the parameters marked ○.</p> <table border="1" style="width: 100%; border-collapse: collapse; text-align: center;"> <thead> <tr> <th>PA19</th> <th>Setting operation</th> <th>PA</th> <th>PB</th> <th>PC</th> <th>PD</th> <th>Po</th> </tr> </thead> <tbody> <tr> <td rowspan="2">0000h</td> <td>Reference</td> <td>○</td> <td>△</td> <td>△</td> <td>△</td> <td>△</td> </tr> <tr> <td>Write</td> <td>○</td> <td>△</td> <td>△</td> <td>△</td> <td>△</td> </tr> <tr> <td rowspan="2">000Bh</td> <td>Reference</td> <td>○</td> <td>○</td> <td>○</td> <td>△</td> <td>△</td> </tr> <tr> <td>Write</td> <td>○</td> <td>○</td> <td>○</td> <td>△</td> <td>△</td> </tr> <tr> <td rowspan="2">000Ch (initial value)</td> <td>Reference</td> <td>○</td> <td>○</td> <td>○</td> <td>○</td> <td>△</td> </tr> <tr> <td>Write</td> <td>○</td> <td>○</td> <td>○</td> <td>○</td> <td>△</td> </tr> <tr> <td rowspan="2">000Eh</td> <td>Reference</td> <td>○</td> <td>○</td> <td>○</td> <td>○</td> <td>○</td> </tr> <tr> <td>Write</td> <td>○</td> <td>○</td> <td>○</td> <td>○</td> <td>○</td> </tr> <tr> <td rowspan="2">100Bh</td> <td>Reference</td> <td>○</td> <td>△</td> <td>△</td> <td>△</td> <td>△</td> </tr> <tr> <td>Write</td> <td>Only 19</td> <td>△</td> <td>△</td> <td>△</td> <td>△</td> </tr> <tr> <td rowspan="2">100Eh</td> <td>Reference</td> <td>○</td> <td>○</td> <td>○</td> <td>○</td> <td>○</td> </tr> <tr> <td>Write</td> <td>Only 19</td> <td>○</td> <td>○</td> <td>○</td> <td>○</td> </tr> </tbody> </table>	PA19	Setting operation	PA	PB	PC	PD	Po	0000h	Reference	○	△	△	△	△	Write	○	△	△	△	△	000Bh	Reference	○	○	○	△	△	Write	○	○	○	△	△	000Ch (initial value)	Reference	○	○	○	○	△	Write	○	○	○	○	△	000Eh	Reference	○	○	○	○	○	Write	○	○	○	○	○	100Bh	Reference	○	△	△	△	△	Write	Only 19	△	△	△	△	100Eh	Reference	○	○	○	○	○	Write	Only 19	○	○	○	○	000Ch	PA19	<p>Parameter writing inhibit</p> <p>Select a reference range and writing range of the parameter.</p> <p>To enable read/write the positioning control parameters ([Pr. PT_]), set [Pr. PA19] to "0 0 A B" in the positioning mode.</p> <p>Refer to table 6.4 for settings.</p> <p style="text-align: center;">Table 6.4 [Pr. PA19] setting value and reading/writing range</p> <table border="1" style="width: 100%; border-collapse: collapse; text-align: center;"> <thead> <tr> <th>PA19</th> <th>Setting operation</th> <th>PA</th> <th>PB</th> <th>PC</th> <th>PD</th> <th>PE</th> <th>PF</th> <th>PL</th> <th>Po</th> <th>PT</th> </tr> </thead> <tbody> <tr> <td rowspan="2">Other than below</td> <td>Reading</td> <td>○</td> <td>△</td> <td>△</td> <td>△</td> <td>△</td> <td>△</td> <td>△</td> <td>△</td> <td>△</td> </tr> <tr> <td>Writing</td> <td>○</td> <td>△</td> <td>△</td> <td>△</td> <td>△</td> <td>△</td> <td>△</td> <td>△</td> <td>△</td> </tr> <tr> <td rowspan="2">000Ah</td> <td>Reading</td> <td>Only 19</td> <td>△</td> <td>△</td> <td>△</td> <td>△</td> <td>△</td> <td>△</td> <td>△</td> <td>△</td> </tr> <tr> <td>Writing</td> <td>Only 19</td> <td>△</td> <td>△</td> <td>△</td> <td>△</td> <td>△</td> <td>△</td> <td>△</td> <td>△</td> </tr> <tr> <td rowspan="2">000Bh</td> <td>Reading</td> <td>○</td> <td>○</td> <td>○</td> <td>△</td> <td>△</td> <td>△</td> <td>△</td> <td>△</td> <td>△</td> </tr> <tr> <td>Writing</td> <td>○</td> <td>○</td> <td>○</td> <td>△</td> <td>△</td> <td>△</td> <td>△</td> <td>△</td> <td>△</td> </tr> <tr> <td rowspan="2">000Ch</td> <td>Reading</td> <td>○</td> <td>○</td> <td>○</td> <td>○</td> <td>△</td> <td>△</td> <td>△</td> <td>△</td> <td>△</td> </tr> <tr> <td>Writing</td> <td>○</td> <td>○</td> <td>○</td> <td>○</td> <td>△</td> <td>△</td> <td>△</td> <td>△</td> <td>△</td> </tr> <tr> <td rowspan="2">00AAh (initial value)</td> <td>Reading</td> <td>○</td> <td>○</td> <td>○</td> <td>○</td> <td>○</td> <td>○</td> <td>○</td> <td>○</td> <td>○</td> </tr> <tr> <td>Writing</td> <td>○</td> <td>○</td> <td>○</td> <td>○</td> <td>○</td> <td>○</td> <td>○</td> <td>○</td> <td>○</td> </tr> <tr> <td rowspan="2">00ABh</td> <td>Reading</td> <td>○</td> <td>○</td> <td>○</td> <td>○</td> <td>○</td> <td>○</td> <td>○</td> <td>○</td> <td>○</td> </tr> <tr> <td>Writing</td> <td>○</td> <td>○</td> <td>○</td> <td>○</td> <td>○</td> <td>○</td> <td>○</td> <td>○</td> <td>○</td> </tr> <tr> <td rowspan="2">100Bh</td> <td>Reading</td> <td>○</td> <td>△</td> <td>△</td> <td>△</td> <td>△</td> <td>△</td> <td>△</td> <td>△</td> <td>△</td> </tr> <tr> <td>Writing</td> <td>Only 19</td> <td>△</td> <td>△</td> <td>△</td> <td>△</td> <td>△</td> <td>△</td> <td>△</td> <td>△</td> </tr> <tr> <td rowspan="2">100Ch</td> <td>Reading</td> <td>○</td> <td>○</td> <td>○</td> <td>○</td> <td>△</td> <td>△</td> <td>△</td> <td>△</td> <td>△</td> </tr> <tr> <td>Writing</td> <td>Only 19</td> <td>○</td> <td>○</td> <td>○</td> <td>△</td> <td>△</td> <td>△</td> <td>△</td> <td>△</td> </tr> <tr> <td rowspan="2">10AAh</td> <td>Reading</td> <td>○</td> <td>○</td> <td>○</td> <td>○</td> <td>○</td> <td>○</td> <td>○</td> <td>○</td> <td>○</td> </tr> <tr> <td>Writing</td> <td>Only 19</td> <td>○</td> <td>○</td> <td>○</td> <td>○</td> <td>○</td> <td>○</td> <td>○</td> <td>○</td> </tr> <tr> <td rowspan="2">10ABh</td> <td>Reading</td> <td>○</td> <td>○</td> <td>○</td> <td>○</td> <td>○</td> <td>○</td> <td>○</td> <td>○</td> <td>○</td> </tr> <tr> <td>Writing</td> <td>Only 19</td> <td>○</td> <td>○</td> <td>○</td> <td>○</td> <td>○</td> <td>○</td> <td>○</td> <td>○</td> </tr> </tbody> </table>	PA19	Setting operation	PA	PB	PC	PD	PE	PF	PL	Po	PT	Other than below	Reading	○	△	△	△	△	△	△	△	△	Writing	○	△	△	△	△	△	△	△	△	000Ah	Reading	Only 19	△	△	△	△	△	△	△	△	Writing	Only 19	△	△	△	△	△	△	△	△	000Bh	Reading	○	○	○	△	△	△	△	△	△	Writing	○	○	○	△	△	△	△	△	△	000Ch	Reading	○	○	○	○	△	△	△	△	△	Writing	○	○	○	○	△	△	△	△	△	00AAh (initial value)	Reading	○	○	○	○	○	○	○	○	○	Writing	○	○	○	○	○	○	○	○	○	00ABh	Reading	○	○	○	○	○	○	○	○	○	Writing	○	○	○	○	○	○	○	○	○	100Bh	Reading	○	△	△	△	△	△	△	△	△	Writing	Only 19	△	△	△	△	△	△	△	△	100Ch	Reading	○	○	○	○	△	△	△	△	△	Writing	Only 19	○	○	○	△	△	△	△	△	10AAh	Reading	○	○	○	○	○	○	○	○	○	Writing	Only 19	○	○	○	○	○	○	○	○	10ABh	Reading	○	○	○	○	○	○	○	○	○	Writing	Only 19	○	○	○	○	○	○	○	○	00AAh
PA19	Setting operation	PA	PB	PC	PD	Po																																																																																																																																																																																																																																																																																																																	
0000h	Reference	○	△	△	△	△																																																																																																																																																																																																																																																																																																																	
	Write	○	△	△	△	△																																																																																																																																																																																																																																																																																																																	
000Bh	Reference	○	○	○	△	△																																																																																																																																																																																																																																																																																																																	
	Write	○	○	○	△	△																																																																																																																																																																																																																																																																																																																	
000Ch (initial value)	Reference	○	○	○	○	△																																																																																																																																																																																																																																																																																																																	
	Write	○	○	○	○	△																																																																																																																																																																																																																																																																																																																	
000Eh	Reference	○	○	○	○	○																																																																																																																																																																																																																																																																																																																	
	Write	○	○	○	○	○																																																																																																																																																																																																																																																																																																																	
100Bh	Reference	○	△	△	△	△																																																																																																																																																																																																																																																																																																																	
	Write	Only 19	△	△	△	△																																																																																																																																																																																																																																																																																																																	
100Eh	Reference	○	○	○	○	○																																																																																																																																																																																																																																																																																																																	
	Write	Only 19	○	○	○	○																																																																																																																																																																																																																																																																																																																	
PA19	Setting operation	PA	PB	PC	PD	PE	PF	PL	Po	PT																																																																																																																																																																																																																																																																																																													
Other than below	Reading	○	△	△	△	△	△	△	△	△																																																																																																																																																																																																																																																																																																													
	Writing	○	△	△	△	△	△	△	△	△																																																																																																																																																																																																																																																																																																													
000Ah	Reading	Only 19	△	△	△	△	△	△	△	△																																																																																																																																																																																																																																																																																																													
	Writing	Only 19	△	△	△	△	△	△	△	△																																																																																																																																																																																																																																																																																																													
000Bh	Reading	○	○	○	△	△	△	△	△	△																																																																																																																																																																																																																																																																																																													
	Writing	○	○	○	△	△	△	△	△	△																																																																																																																																																																																																																																																																																																													
000Ch	Reading	○	○	○	○	△	△	△	△	△																																																																																																																																																																																																																																																																																																													
	Writing	○	○	○	○	△	△	△	△	△																																																																																																																																																																																																																																																																																																													
00AAh (initial value)	Reading	○	○	○	○	○	○	○	○	○																																																																																																																																																																																																																																																																																																													
	Writing	○	○	○	○	○	○	○	○	○																																																																																																																																																																																																																																																																																																													
00ABh	Reading	○	○	○	○	○	○	○	○	○																																																																																																																																																																																																																																																																																																													
	Writing	○	○	○	○	○	○	○	○	○																																																																																																																																																																																																																																																																																																													
100Bh	Reading	○	△	△	△	△	△	△	△	△																																																																																																																																																																																																																																																																																																													
	Writing	Only 19	△	△	△	△	△	△	△	△																																																																																																																																																																																																																																																																																																													
100Ch	Reading	○	○	○	○	△	△	△	△	△																																																																																																																																																																																																																																																																																																													
	Writing	Only 19	○	○	○	△	△	△	△	△																																																																																																																																																																																																																																																																																																													
10AAh	Reading	○	○	○	○	○	○	○	○	○																																																																																																																																																																																																																																																																																																													
	Writing	Only 19	○	○	○	○	○	○	○	○																																																																																																																																																																																																																																																																																																													
10ABh	Reading	○	○	○	○	○	○	○	○	○																																																																																																																																																																																																																																																																																																													
	Writing	Only 19	○	○	○	○	○	○	○	○																																																																																																																																																																																																																																																																																																													
PB01	<p>Adaptive tuning mode (adaptive filter II)</p> <p>Select the setting method for filter tuning. Setting this parameter to "___ 1" (filter tuning mode 1) automatically changes the machine resonance suppression filter 1 ([Pr. PB13]) and notch shape selection ([Pr. PB14]).</p> <div style="display: flex; flex-direction: column; align-items: center;">   </div> <p>0 0 0 x:</p> <p>Filter tuning mode selection</p> <p>0: Filter OFF ([Pr. PB13] and [Pr. PB14] are fixed to the initial values.)</p> <p>1: Filter tuning mode (Automatically set parameter: [Pr. PB13]/[Pr. PB14])</p> <p>2: Manual mode</p> <p>When this parameter is set to "___ 1", the tuning is completed after positioning is done the predetermined number or times for the predetermined period of time, and the setting changes to "___ 2". When the filter tuning is not necessary, the setting changes to "___ 0". When this parameter is set to "___ 0", the initial values are set to the machine resonance suppression filter 1 and notch shape selection. However, this does not occur when the servo off.</p>	0000h	PB01	<p>Adaptive tuning mode (adaptive filter II)</p> <p>Filter tuning mode selection</p> <p>Set the adaptive tuning.</p> <p>Select the adjustment mode of the machine resonance suppression filter 1. For details, refer to section 7.1.2 of "MR-J4-_A_-RJ)/MR-J4-03A6(-RJ) Servo Amplifier Instruction Manual".</p> <p>___ x:</p> <p>0: Disabled</p> <p>1: Automatic setting</p> <p>2: Manual setting</p> <p>___ x _:</p> <p>For manufacturer setting</p> <p>_ x _ _:</p> <p>For manufacturer setting</p> <p>x _ _ _:</p> <p>Tuning accuracy selection</p> <p>0: Standard</p> <p>1: High accuracy</p> <p>The frequency is estimated more accurately in the high accuracy mode compared to the standard mode. However, the tuning sound may be larger in the high accuracy mode.</p> <p>For details, refer to section 7.1.2 of "MR-J4-_A_-RJ)/MR-J4-03A6(-RJ) Servo Amplifier Instruction Manual".</p> <p>This digit is available with servo amplifier with software version C5 or later.</p>	0h																																																																																																																																																																																																																																																																																																																		

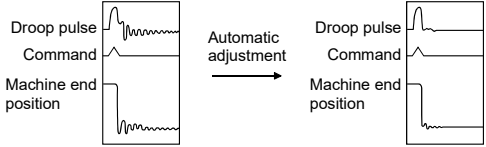
MR-J3-_T_			MR-J4-_A_-RJ		
No.	Name and function	Initial value	No.	Name and function	Initial value
PB02	<p>Vibration suppression control tuning mode (advanced vibration suppression control)</p> <p>The vibration suppression is valid when the [Pr. PA08] (auto tuning) setting is "___2" or "___3". When [Pr. PA08] is "___1", vibration suppression is always invalid. Select the setting method for vibration suppression control tuning. Setting this parameter to "___1" (vibration suppression control tuning mode) automatically changes the vibration suppression control - vibration frequency ([Pr. PB19]) and vibration suppression control - resonance frequency ([Pr. PB20]) after positioning is done the predetermined number of times.</p>  <p>0 0 0 x: Vibration suppression control tuning mode 0: Vibration suppression control OFF ([Pr. PB19] and [Pr. PB20] are fixed to the initial values.) 1: Vibration suppression control tuning mode (Advanced vibration suppression control) (Automatically set parameter [Pr. PB19]/[Pr. PB20]) 2: Manual mode</p> <p>When this parameter is set to "___1", the tuning is completed after positioning is done the predetermined number or times for the predetermined period of time, and the setting changes to "___2". When the vibration suppression control tuning is not necessary, the setting changes to "___0". When this parameter is set to "___0", the initial values are set to the vibration suppression control - vibration frequency and vibration suppression control - resonance frequency. However, this does not occur when the servo off.</p>	0000h	PB02	<p>Vibration suppression control tuning mode (advanced vibration suppression control II)</p> <p>Vibration suppression control 1 tuning mode selection Select the tuning mode of the vibration suppression control 1. For details, refer to section 7.1.5 of "MR-J4-_A_-RJ/MR-J4-03A6(-RJ) Servo Amplifier Instruction Manual". ___ x: 0: Disabled 1: Automatic setting 2: Manual setting</p>	0h
				<p>__ x _: Vibration suppression control 2 tuning mode selection Select the tuning mode of the vibration suppression control 2. To enable the digit, select "3 inertia mode (___1)" of "Vibration suppression mode selection" in [Pr. PA24]. For details, refer to section 7.1.5 of "MR-J4-_A_-RJ Servo Amplifier Instruction Manual". 0: Disabled 1: Automatic setting 2: Manual setting</p>	0h
				_ x _ _: For manufacturer setting	0h
				x _ _ _: For manufacturer setting	0h
PB04	<p>Feed forward gain</p> <p>Set the feed forward gain. When the setting is 100%, the droop pulses during operation at constant speed are nearly zero. However, sudden acceleration/deceleration will increase the overshoot. As a guideline, when the feed forward gain setting is 100%, set 1 s or more as the acceleration/deceleration time constant up to the rated speed.</p>	0	PB04	<p>Feed forward gain</p> <p>Set the feed forward gain. When the setting is 100%, the droop pulses during operation at constant speed are nearly zero. However, sudden acceleration/deceleration will increase the overshoot. As a guideline, when the feed forward gain setting is 100%, set 1 s or more as the acceleration time constant up to the rated speed.</p> <p>Setting range: 0 to 100</p>	0

MR-J3-_T_			MR-J4-_A_-RJ												
No.	Name and function	Initial value	No.	Name and function	Initial value										
PB06	<p>Ratio of load inertia moment to servo motor inertia moment</p> <p>Used to set the ratio of the load inertia moment to the servo motor shaft inertia moment. When auto tuning mode 1 and interpolation mode is selected, the result of auto tuning is automatically used.</p> <p>In this case, it varies between 0 and 100.0.</p>	7.0	PB06	<p>Load to motor inertia ratio/load to motor mass ratio</p> <p>This is used to set the load to motor inertia ratio or load to motor mass ratio.</p> <p>Setting a value considerably different from the actual load moment of inertia may cause an unexpected operation such as an overshoot.</p> <p>The setting of the parameter will be the automatic setting or manual setting depending on the [Pr. PA08] setting. Refer to the following table for details. When the parameter is automatic setting, the value will vary between 0.00 and 100.00.</p> <p>Setting range: 0.00 to 300.00</p> <table border="1" style="width: 100%; border-collapse: collapse;"> <thead> <tr> <th style="width: 70%;">Pr. PA08</th> <th style="width: 30%;">This parameter</th> </tr> </thead> <tbody> <tr> <td>___ 0 (2 gain adjustment mode 1 (interpolation mode))</td> <td rowspan="2">Automatic setting</td> </tr> <tr> <td>___ 1 (Auto tuning mode 1)</td> </tr> <tr> <td>___ 2 (Auto tuning mode 2)</td> <td rowspan="2">Manual setting</td> </tr> <tr> <td>___ 3 (Manual mode)</td> </tr> <tr> <td>___ 4 (2 gain adjustment mode 2)</td> <td></td> </tr> </tbody> </table>	Pr. PA08	This parameter	___ 0 (2 gain adjustment mode 1 (interpolation mode))	Automatic setting	___ 1 (Auto tuning mode 1)	___ 2 (Auto tuning mode 2)	Manual setting	___ 3 (Manual mode)	___ 4 (2 gain adjustment mode 2)		7.00
Pr. PA08	This parameter														
___ 0 (2 gain adjustment mode 1 (interpolation mode))	Automatic setting														
___ 1 (Auto tuning mode 1)															
___ 2 (Auto tuning mode 2)	Manual setting														
___ 3 (Manual mode)															
___ 4 (2 gain adjustment mode 2)															
PB07	<p>Model loop gain</p> <p>Set the response gain up to the target position. Increase the gain to improve track ability in response to the command.</p> <p>When auto turning mode 1 - 2, is selected, the result of auto turning is automatically used.</p>	24	PB07	<p>Model loop gain</p> <p>Set the response gain up to the target position. Increasing the setting value will also increase the response level to the position command but will be liable to generate vibration and noise.</p> <p>The setting of the parameter will be the automatic setting or manual setting depending on the [Pr. PA08] setting. Refer to the following table for details.</p> <p>Setting range: 1.0 to 2000.0</p> <table border="1" style="width: 100%; border-collapse: collapse;"> <thead> <tr> <th style="width: 70%;">Pr. PA08</th> <th style="width: 30%;">This parameter</th> </tr> </thead> <tbody> <tr> <td>___ 0 (2 gain adjustment mode 1 (interpolation mode))</td> <td>Manual setting</td> </tr> <tr> <td>___ 1 (Auto tuning mode 1)</td> <td rowspan="2">Automatic setting</td> </tr> <tr> <td>___ 2 (Auto tuning mode 2)</td> </tr> <tr> <td>___ 3 (Manual mode)</td> <td rowspan="2">Manual setting</td> </tr> <tr> <td>___ 4 (2 gain adjustment mode 2)</td> </tr> </tbody> </table>	Pr. PA08	This parameter	___ 0 (2 gain adjustment mode 1 (interpolation mode))	Manual setting	___ 1 (Auto tuning mode 1)	Automatic setting	___ 2 (Auto tuning mode 2)	___ 3 (Manual mode)	Manual setting	___ 4 (2 gain adjustment mode 2)	15.0
Pr. PA08	This parameter														
___ 0 (2 gain adjustment mode 1 (interpolation mode))	Manual setting														
___ 1 (Auto tuning mode 1)	Automatic setting														
___ 2 (Auto tuning mode 2)															
___ 3 (Manual mode)	Manual setting														
___ 4 (2 gain adjustment mode 2)															
PB08	<p>Position loop gain</p> <p>Used to set the gain of the position loop.</p> <p>Set this parameter to increase the position response to level load disturbance. Higher setting increases the response level but is liable to generate vibration and/or noise.</p> <p>When auto tuning mode 1 - 2, and interpolation mode is selected, the result of auto tuning is automatically used.</p>	37	PB08	<p>Position loop gain</p> <p>This is used to set the gain of the position loop.</p> <p>Set this parameter to increase the position response to level load disturbance.</p> <p>Increasing the setting value will also increase the response level to the load disturbance but will be liable to generate vibration and noise.</p> <p>The setting of the parameter will be the automatic setting or manual setting depending on the [Pr. PA08] setting. Refer to the following table for details.</p> <p>Setting range: 1.0 to 2000.0</p> <table border="1" style="width: 100%; border-collapse: collapse;"> <thead> <tr> <th style="width: 70%;">Pr. PA08</th> <th style="width: 30%;">This parameter</th> </tr> </thead> <tbody> <tr> <td>___ 0 (2 gain adjustment mode 1 (interpolation mode))</td> <td rowspan="2">Automatic setting</td> </tr> <tr> <td>___ 1 (Auto tuning mode 1)</td> </tr> <tr> <td>___ 2 (Auto tuning mode 2)</td> <td rowspan="2">Manual setting</td> </tr> <tr> <td>___ 3 (Manual mode)</td> </tr> <tr> <td>___ 4 (2 gain adjustment mode 2)</td> <td>Automatic setting</td> </tr> </tbody> </table>	Pr. PA08	This parameter	___ 0 (2 gain adjustment mode 1 (interpolation mode))	Automatic setting	___ 1 (Auto tuning mode 1)	___ 2 (Auto tuning mode 2)	Manual setting	___ 3 (Manual mode)	___ 4 (2 gain adjustment mode 2)	Automatic setting	37.0
Pr. PA08	This parameter														
___ 0 (2 gain adjustment mode 1 (interpolation mode))	Automatic setting														
___ 1 (Auto tuning mode 1)															
___ 2 (Auto tuning mode 2)	Manual setting														
___ 3 (Manual mode)															
___ 4 (2 gain adjustment mode 2)	Automatic setting														

Part 6: Review on Replacement of MR-J3-_T_(DIO command/ Serial communication operation) with MR-J4-_A_-RJ

MR-J3-_T_			MR-J4-_A_-RJ		
No.	Name and function	Initial value	No.	Name and function	Initial value
PB09	<p>Speed loop gain</p> <p>Set this parameter when vibration occurs on machines of low rigidity or large backlash.</p> <p>Higher setting increases the response level but is liable to generate vibration and/or noise.</p> <p>When auto tuning mode 1 - 2, manual mode and interpolation mode is selected, the result of auto tuning is automatically used.</p>	823	PB09	<p>Speed loop gain</p> <p>This is used to set the gain of the speed loop.</p> <p>Set this parameter when vibration occurs on machines of low rigidity or large backlash. Increasing the setting value will also increase the response level but will be liable to generate vibration and noise.</p> <p>The setting of the parameter will be the automatic setting or manual setting depending on the [Pr. PA08] setting. Refer to the table of [Pr. PB08] for details.</p> <p>Setting range: 20 to 65535</p>	823
PB10	<p>Speed integral compensation</p> <p>Used to set the integral time constant of the speed loop.</p> <p>Lower setting increases the response level but is liable to generate vibration and/or noise.</p> <p>When auto tuning mode 1 - 2, and interpolation mode is selected, the result of auto tuning is automatically used.</p>	33.7	PB10	<p>Speed integral compensation</p> <p>Set the integral time constant of the speed loop.</p> <p>Decreasing the setting value will increase the response level but will be liable to generate vibration and noise.</p> <p>The setting of the parameter will be the automatic setting or manual setting depending on the [Pr. PA08] setting. Refer to the table of [Pr. PB08] for details.</p> <p>Setting range: 0.1 to 1000.0</p>	33.7
PB11	<p>Speed differential compensation</p> <p>Used to set the differential compensation.</p> <p>Made valid when the proportion control (PC) is switched on.</p>	980	PB11	<p>Speed differential compensation</p> <p>Set the differential compensation.</p> <p>To enable the setting value, turn on PC (proportional control).</p> <p>Setting range: 0 to 1000</p>	980
PB12	<p>For manufacturer setting</p> <p>Do not change this value by any means.</p>	0	PB12	<p>Overshoot amount compensation</p> <p>Set a percentage of viscous friction torque against the servo motor rated value the rated value.</p> <p>When the response level is low or when the torque is limited, the efficiency of the parameter may be lower.</p> <p>Setting range: 0 to 100</p>	0
PB13	<p>Machine resonance suppression filter 1</p> <p>Set the notch frequency of the machine resonance suppression filter 1.</p> <p>Setting [Pr. PB01] (filter tuning mode 1) to "___ 1" automatically changes this parameter.</p> <p>When the [Pr. PB01] setting is "___ 0", the setting of this parameter is ignored.</p>	4500	PB13	<p>Machine resonance suppression filter 1</p> <p>Set the notch frequency of the machine resonance suppression filter 1.</p> <p>When "Filter tuning mode selection" is set to "Automatic setting (___ 1)" in [Pr. PB01], this parameter will be adjusted automatically by adaptive tuning.</p> <p>When "Filter tuning mode selection" is set to "Manual setting (___ 2)" in [Pr. PB01], the setting value will be enabled.</p> <p>Setting range: 10 to 4500</p>	4500

MR-J3-_T_			MR-J4-_A_-RJ																														
No.	Name and function	Initial value	No.	Name and function	Initial value																												
PB14	<p>Notch shape selection 1 Used to selection the machine resonance suppression filter 1.</p> <p>0 _ x 0: Notch depth selection</p> <table border="1"> <thead> <tr> <th>Setting value</th> <th>Depth</th> <th>Gain</th> </tr> </thead> <tbody> <tr> <td>0</td> <td rowspan="2">Deep</td> <td>-40dB</td> </tr> <tr> <td>1</td> <td>-14dB</td> </tr> <tr> <td>2</td> <td>to</td> <td>-8dB</td> </tr> <tr> <td>3</td> <td>Shallow</td> <td>-4dB</td> </tr> </tbody> </table> <p>0 x _ 0: Notch width</p> <table border="1"> <thead> <tr> <th>Setting value</th> <th>Width</th> <th>α</th> </tr> </thead> <tbody> <tr> <td>0</td> <td rowspan="2">Standard</td> <td>2</td> </tr> <tr> <td>1</td> <td>3</td> </tr> <tr> <td>2</td> <td>to</td> <td>4</td> </tr> <tr> <td>3</td> <td>Wide</td> <td>5</td> </tr> </tbody> </table> <p>Setting [Pr. PB01] (filter tuning mode 1) to "___ 1" automatically changes this parameter. When the [Pr. PB01] setting is "___ 0", the setting of this parameter is ignored.</p>	Setting value	Depth	Gain	0	Deep	-40dB	1	-14dB	2	to	-8dB	3	Shallow	-4dB	Setting value	Width	α	0	Standard	2	1	3	2	to	4	3	Wide	5	0000h	PB14	<p>Notch shape selection 1 Set forms of the machine resonance suppression filter 1. When "Filter tuning mode selection" is set to "Automatic setting (___ 1)" in [Pr. PB01], this parameter will be adjusted automatically by adaptive tuning. When "Filter tuning mode selection" is set to "Manual setting (___ 2)" in [Pr. PB01], the setting value will be enabled.</p> <p>___ x: For manufacturer setting</p> <p>___ x _: Notch depth selection 0: -40 dB 1: -14 dB 2: -8 dB 3: -4 dB</p> <p>_ x _ _: Notch width selection 0: $\alpha = 2$ 1: $\alpha = 3$ 2: $\alpha = 4$ 3: $\alpha = 5$</p> <p>x _ _ _: For manufacturer setting</p>	0h 0h 0h 0h
Setting value	Depth	Gain																															
0	Deep	-40dB																															
1		-14dB																															
2	to	-8dB																															
3	Shallow	-4dB																															
Setting value	Width	α																															
0	Standard	2																															
1		3																															
2	to	4																															
3	Wide	5																															
PB15	<p>Machine resonance suppression filter 2 Set the notch frequency of the machine resonance suppression filter 2. Set [Pr. PB16] (notch shape selection 2) to "___ 1" to make this parameter valid.</p>	4500	PB15	<p>Machine resonance suppression filter 2 Set the notch frequency of the machine resonance suppression filter 2. To enable the setting value, select "Enabled (___ 1)" of "Machine resonance suppression filter 2 selection" in [Pr. PB16].</p> <p>Setting range: 10 to 4500</p>	4500																												
PB16	<p>Notch shape selection 2 Select the shape of the machine resonance suppression filter 2.</p> <p>0 _ _ x: Machine resonance suppression filter 2 selection 0: Disabled 1: Enabled</p> <p>0 _ x _: Notch depth selection</p> <table border="1"> <thead> <tr> <th>Setting value</th> <th>Depth</th> <th>Gain</th> </tr> </thead> <tbody> <tr> <td>0</td> <td rowspan="2">Deep</td> <td>-40dB</td> </tr> <tr> <td>1</td> <td>-14dB</td> </tr> <tr> <td>2</td> <td>to</td> <td>-8dB</td> </tr> <tr> <td>3</td> <td>Shallow</td> <td>-4dB</td> </tr> </tbody> </table> <p>0 x _ _: Notch width</p> <table border="1"> <thead> <tr> <th>Setting value</th> <th>Width</th> <th>α</th> </tr> </thead> <tbody> <tr> <td>0</td> <td rowspan="2">Standard</td> <td>2</td> </tr> <tr> <td>1</td> <td>3</td> </tr> <tr> <td>2</td> <td>to</td> <td>4</td> </tr> <tr> <td>3</td> <td>Wide</td> <td>5</td> </tr> </tbody> </table>	Setting value	Depth	Gain	0	Deep	-40dB	1	-14dB	2	to	-8dB	3	Shallow	-4dB	Setting value	Width	α	0	Standard	2	1	3	2	to	4	3	Wide	5	0000h	PB16	<p>Notch shape selection 2 Set forms of the machine resonance suppression filter 2.</p> <p>___ x: Machine resonance suppression filter 2 selection 0: Disabled 1: Enabled</p> <p>___ x _: Notch depth selection 0: -40 dB 1: -14 dB 2: -8 dB 3: -4 dB</p> <p>_ x _ _: Notch width selection 0: $\alpha = 2$ 1: $\alpha = 3$ 2: $\alpha = 4$ 3: $\alpha = 5$</p> <p>x _ _ _: For manufacturer setting</p>	0h 0h 0h 0h
Setting value	Depth	Gain																															
0	Deep	-40dB																															
1		-14dB																															
2	to	-8dB																															
3	Shallow	-4dB																															
Setting value	Width	α																															
0	Standard	2																															
1		3																															
2	to	4																															
3	Wide	5																															

MR-J3-_T_			MR-J4-_A_-RJ																																																																					
No.	Name and function	Initial value	No.	Name and function	Initial value																																																																			
PB17	Automatic setting parameter The value of this parameter is set according to a set value of [Pr. PB06] (Ratio of load inertia moment to servo motor inertia moment).		PB17	Shaft resonance suppression filter Set the shaft resonance suppression filter. This is used to suppress a low-frequency machine vibration. When "Shaft resonance suppression filter selection" is set to "Automatic setting (___ 0)" in [Pr. PB23], the value will be calculated automatically from the servo motor you use and load to motor inertia ratio. Set manually for "Manual setting (___ 1)". When "Shaft resonance suppression filter selection" is set to "Disabled (___ 2)" in [Pr. PB23], the setting value of this parameter will be disabled. When "Machine resonance suppression filter 4 selection" is set to "Enabled (___ 1)" in [Pr. PB49], the shaft resonance suppression filter is not available.																																																																				
			___ x x: Shaft resonance suppression filter setting frequency selection Refer to table 6.5 for settings. Set the value closest to the frequency you need.	00h																																																																				
			___ x ___: Notch depth selection 0: -40 dB 1: -14 dB 2: -8 dB 3: -4 dB	0h																																																																				
			x ___: For manufacturer setting	0h																																																																				
			Table 7.5 Shaft resonance suppression filter setting frequency selection <table border="1" style="margin-left: auto; margin-right: auto;"> <thead> <tr> <th>Setting value</th> <th>Frequency [Hz]</th> <th>Setting value</th> <th>Frequency [Hz]</th> </tr> </thead> <tbody> <tr><td>___ 0 0</td><td>Disabled</td><td>___ 1 0</td><td>562</td></tr> <tr><td>___ 0 1</td><td>Disabled</td><td>___ 1 1</td><td>529</td></tr> <tr><td>___ 0 2</td><td>4500</td><td>___ 1 2</td><td>500</td></tr> <tr><td>___ 0 3</td><td>3000</td><td>___ 1 3</td><td>473</td></tr> <tr><td>___ 0 4</td><td>2250</td><td>___ 1 4</td><td>450</td></tr> <tr><td>___ 0 5</td><td>1800</td><td>___ 1 5</td><td>428</td></tr> <tr><td>___ 0 6</td><td>1500</td><td>___ 1 6</td><td>409</td></tr> <tr><td>___ 0 7</td><td>1285</td><td>___ 1 7</td><td>391</td></tr> <tr><td>___ 0 8</td><td>1125</td><td>___ 1 8</td><td>375</td></tr> <tr><td>___ 0 9</td><td>1000</td><td>___ 1 9</td><td>360</td></tr> <tr><td>___ 0 A</td><td>900</td><td>___ 1 A</td><td>346</td></tr> <tr><td>___ 0 B</td><td>818</td><td>___ 1 B</td><td>333</td></tr> <tr><td>___ 0 C</td><td>750</td><td>___ 1 C</td><td>321</td></tr> <tr><td>___ 0 D</td><td>692</td><td>___ 1 D</td><td>310</td></tr> <tr><td>___ 0 E</td><td>642</td><td>___ 1 E</td><td>300</td></tr> <tr><td>___ 0 F</td><td>600</td><td>___ 1 F</td><td>290</td></tr> </tbody> </table>		Setting value	Frequency [Hz]	Setting value	Frequency [Hz]	___ 0 0	Disabled	___ 1 0	562	___ 0 1	Disabled	___ 1 1	529	___ 0 2	4500	___ 1 2	500	___ 0 3	3000	___ 1 3	473	___ 0 4	2250	___ 1 4	450	___ 0 5	1800	___ 1 5	428	___ 0 6	1500	___ 1 6	409	___ 0 7	1285	___ 1 7	391	___ 0 8	1125	___ 1 8	375	___ 0 9	1000	___ 1 9	360	___ 0 A	900	___ 1 A	346	___ 0 B	818	___ 1 B	333	___ 0 C	750	___ 1 C	321	___ 0 D	692	___ 1 D	310	___ 0 E	642	___ 1 E	300	___ 0 F	600	___ 1 F	290
Setting value	Frequency [Hz]	Setting value	Frequency [Hz]																																																																					
___ 0 0	Disabled	___ 1 0	562																																																																					
___ 0 1	Disabled	___ 1 1	529																																																																					
___ 0 2	4500	___ 1 2	500																																																																					
___ 0 3	3000	___ 1 3	473																																																																					
___ 0 4	2250	___ 1 4	450																																																																					
___ 0 5	1800	___ 1 5	428																																																																					
___ 0 6	1500	___ 1 6	409																																																																					
___ 0 7	1285	___ 1 7	391																																																																					
___ 0 8	1125	___ 1 8	375																																																																					
___ 0 9	1000	___ 1 9	360																																																																					
___ 0 A	900	___ 1 A	346																																																																					
___ 0 B	818	___ 1 B	333																																																																					
___ 0 C	750	___ 1 C	321																																																																					
___ 0 D	692	___ 1 D	310																																																																					
___ 0 E	642	___ 1 E	300																																																																					
___ 0 F	600	___ 1 F	290																																																																					
PB18	Low-pass filter setting Set the low-pass filter. Setting [Pr. PB23] (low-pass filter selection) to "___ 0_" automatically changes this parameter. When [Pr. PB23] is set to "___ 1_", this parameter can be set manually.	3141	PB18	Low-pass filter setting Set the low-pass filter. The following shows a relation of a required parameter to this parameter. Setting range: 100 to 18000	3141																																																																			
			<table border="1" style="margin-left: auto; margin-right: auto;"> <thead> <tr> <th>[Pr. PB23]</th> <th>[Pr. PB18]</th> </tr> </thead> <tbody> <tr> <td>___ 0_ (Initial value)</td> <td>Automatic setting</td> </tr> <tr> <td>___ 1_</td> <td>Setting value enabled</td> </tr> <tr> <td>___ 2_</td> <td>Setting value disabled</td> </tr> </tbody> </table>	[Pr. PB23]	[Pr. PB18]	___ 0_ (Initial value)	Automatic setting	___ 1_	Setting value enabled	___ 2_	Setting value disabled																																																													
[Pr. PB23]	[Pr. PB18]																																																																							
___ 0_ (Initial value)	Automatic setting																																																																							
___ 1_	Setting value enabled																																																																							
___ 2_	Setting value disabled																																																																							

Part 6: Review on Replacement of MR-J3-_T_(DIO command/ Serial communication operation) with MR-J4-_A_-RJ

MR-J3-_T_			MR-J4-_A_-RJ		
No.	Name and function	Initial value	No.	Name and function	Initial value
PB19	Vibration suppression control - vibration frequency setting Set the vibration frequency for vibration suppression control to suppress low-frequency machine vibration, such as enclosure vibration. Setting [Pr. PB02] (vibration suppression control tuning mode) to "___ 1" automatically changes this parameter. When [Pr. PB02] is set to "___ 2", this parameter can be set manually.	100.0	PB19	Vibration suppression control 1 – Vibration frequency Set the vibration frequency for vibration suppression control 1 to suppress low-frequency machine vibration. When "Vibration suppression control 1 tuning mode selection" is set to "Automatic setting (___ 1)" in [Pr. PB02], this parameter will be set automatically. When "Manual setting (___ 2)" is selected, the setting written to the parameter is used. For details, refer to section 7.1.5 of "MR-J4-_A_-RJ)/MR-J4-03A6(-RJ) Servo Amplifier Instruction Manual". Setting range: 0.1 to 300.0	100.0
PB20	Vibration suppression control - resonance frequency setting Set the resonance frequency for vibration suppression control to suppress low-frequency machine vibration, such as enclosure vibration. Setting [Pr. PB02] (vibration suppression control tuning mode) to "___ 1" automatically changes this parameter. When [Pr. PB02] is set to "___ 2", this parameter can be set manually.	100.0	PB20	Vibration suppression control 1 – Resonance frequency Set the resonance frequency for vibration suppression control 1 to suppress low-frequency machine vibration. When "Vibration suppression control 1 tuning mode selection" is set to "Automatic setting (___ 1)" in [Pr. PB02], this parameter will be set automatically. When "Manual setting (___ 2)" is selected, the setting written to the parameter is used. For details, refer to section 7.1.5 of "MR-J4-_A_-RJ)/MR-J4-03A6(-RJ) Servo Amplifier Instruction Manual". Setting range: 0.1 to 300.0	100.0
PB23	Low-pass filter selection Select the low-pass filter. 0 0 x 0: Low-pass filter selection 0: Automatic setting 1: Manual setting ([Pr. PB18] setting)	0000h	PB23	Low-pass filter selection ___ x: Shaft resonance suppression filter selection Select the shaft resonance suppression filter. 0: Automatic setting 1: Manual setting 2: Disabled When you select "Enabled (___ 1)" of "Machine resonance suppression filter 4 selection" in [Pr. PB49], the shaft resonance suppression filter is not available.	0h
			___ x _:	Low-pass filter selection Select the low-pass filter. 0: Automatic setting 1: Manual setting 2: Disabled	0h
			_ x _ _:	For manufacturer setting	0h
			x _ _ _:	For manufacturer setting	0h
PB24	Slight vibration suppression control selection Select the slight vibration suppression control. When [Pr. PA08] (auto tuning mode) is set to "___ 3", this parameter is made valid. 0 0 0 x: Slight vibration suppression control selection 0: Disabled 1: Enabled	0000h	PB24	Slight vibration suppression control ___ x: Slight vibration suppression control selection Select the slight vibration suppression control. 0: Disabled 1: Enabled To enable the slight vibration suppression control, select "Manual mode (___ 3)" of "Gain adjustment mode selection" in [Pr. PA08].	0h
			___ x _:	For manufacturer setting	0h
			_ x _ _:	For manufacturer setting	0h
			x _ _ _:	For manufacturer setting	0h

MR-J3-_T_			MR-J4-_A_-RJ		
No.	Name and function	Initial value	No.	Name and function	Initial value
PB26	Gain changing selection Select the gain changing condition.	0000h	PB26	Gain switching function Select the gain switching condition. Set conditions to enable the gain switching values set in [Pr. PB29] to [Pr. PB36] and [Pr. PB56] to [Pr. PB60].	0h
	0 0 _ x: Gain changing selection Under any of the following conditions, the gains change on the basis of the [Pr. PB29] to [Pr. PB34] settings. 0: Disabled 1: Gain changing (CDP) is ON 2: Command frequency ([Pr. PB27] setting) 3: Droop pulse value ([Pr. PB27] setting) 4: Servo motor speed ([Pr. PB27] setting)			___ x: Gain switching selection 0: Disabled 1: Input device (gain switching (CDP)) 2: Command frequency (Note) 3: Droop pulses 4: Servo motor speed Note. This will be a frequency of the servo motor side (load side for the fully closed loop control) command pulse unit.	
	0 0 x _: Gain changing condition 0: Valid at more than condition (Valid when gain changing (CDP) is ON) 1: Valid at less than condition (Valid when gain changing (CDP) is OFF)			__ x _: Gain switching condition selection 0: Gain after switching is enabled with gain switching condition or more 1: Gain after switching is enabled with gain switching condition or less	
				_ x _ _: For manufacturer setting	
				x _ _ _: For manufacturer setting	0h
PB27	Gain changing condition Used to set the value of gain changing condition (command frequency, droop pulses, servo motor speed) selected in [Pr. PB26]. The set value unit changes with the changing condition item.	10	PB27	Gain switching condition This is used to set the value of gain switching (command frequency, droop pulses, and servo motor speed) selected in [Pr. PB26]. The set value unit differs depending on the switching condition item. (Refer to "MR-J4-_A_-(-RJ)/MR-J4-03A6(-RJ) Servo Amplifier Instruction Manual" section 7.2.3.) Setting range: 0 to 9999	10
PB28	Gain changing time constant Used to set the time constant at which the gains will change in response to the conditions set in [Pr. PB26] and [Pr. PB27].	1	PB28	Gain switching time constant Set the time constant at which the gains will change in response to the conditions set in [Pr. PB26] and [Pr. PB27]. Setting range: 0 to 100	1
PB29	Gain changing ratio of load inertia moment to servo motor inertia moment Used to set the ratio of load inertia moment to servo motor inertia moment when gain changing is valid. This parameter is made valid when the auto tuning is invalid ([Pr. PA08]: "___ 3").	7.0	PB29	Load to motor inertia ratio/load to motor mass ratio after gain switching Set the load to motor inertia ratio/load to motor mass ratio for when gain switching is enabled. This parameter is enabled only when you select "Manual mode (___ 3)" of "Gain adjustment mode selection" in [Pr. PA08]. Setting range: 0.00 to 300.00	7.00
PB30	Gain changing position loop gain Set the position loop gain when the gain changing is valid. This parameter is made valid when the auto tuning is invalid ([Pr. PA08]: "___ 3").	37	PB30	Position loop gain after gain switching Set the position loop gain for when the gain switching is enabled. When you set a value less than 1.0 rad/s, the value will be the same as [Pr. PB08]. This parameter is enabled only when you select "Manual mode (___ 3)" of "Gain adjustment mode selection" in [Pr. PA08]. Setting range: 0.0 to 2000.0	0.0

MR-J3-_T_			MR-J4-_A_-RJ		
No.	Name and function	Initial value	No.	Name and function	Initial value
PB31	Gain changing speed loop gain Set the speed loop gain when the gain changing is valid. This parameter is made valid when the auto tuning is invalid ([Pr. PA08]: "___3").	823	PB31	Speed loop gain after gain switching Set the speed loop gain for when the gain switching is enabled. When you set a value less than 20 rad/s, the value will be the same as [Pr. PB09]. This parameter is enabled only when you select "Manual mode (___3)" of "Gain adjustment mode selection" in [Pr. PA08]. Setting range: 0 to 65535	0
PB32	Gain changing speed integral compensation Set the speed integral compensation when the gain changing is valid. This parameter is made valid when the auto tuning is invalid ([Pr. PA08]: "___3").	33.7	PB32	Speed integral compensation after gain switching Set the speed integral compensation for when the gain switching is enabled. When you set a value less than 0.1 ms, the value will be the same as [Pr. PB10]. This parameter is enabled only when you select "Manual mode (___3)" of "Gain adjustment mode selection" in [Pr. PA08]. Setting range: 0.0 to 5000.0	0.0
PB33	Gain changing vibration suppression control vibration frequency setting Set the vibration frequency for vibration suppression control when the gain changing is valid. This parameter is made valid when the [Pr. PB02] setting is "___2" and the [Pr. PB26] setting is "___1". When using the vibration suppression control gain changing, always execute the changing after the servo motor has stopped.	100.0	PB33	Vibration suppression control 1 – Vibration frequency after gain switching Set the vibration frequency for vibration suppression control 1 for when the gain switching is enabled. When you set a value less than 0.1 Hz, the value will be the same as [Pr. PB19]. This parameter will be enabled only when the following conditions are fulfilled. <ul style="list-style-type: none"> ▪ "Gain adjustment mode selection" in [Pr. PA08] is "Manual mode (___3)". ▪ "Vibration suppression control 1 tuning mode selection" in [Pr. PB02] is "Manual setting (___2)". ▪ "Gain switching selection" in [Pr. PB26] is "Input device (gain switching (CDP)) (___1)". Switching during driving may cause a shock. Be sure to switch them after the servo motor stops. Setting range: 0.0 to 300.0	0.0
PB34	Gain changing vibration suppression control resonance frequency setting Set the resonance frequency for vibration suppression control when the gain changing is valid. This parameter is made valid when the [Pr. PB02] setting is "___2" and the [Pr. PB26] setting is "___1". When using the vibration suppression control gain changing, always execute the changing after the servo motor has stopped.	100.0	PB34	Vibration suppression control 1 – Resonance frequency after gain switching Set the resonance frequency for vibration suppression control 1 for when the gain switching is enabled. When you set a value less than 0.1 Hz, the value will be the same as [Pr. PB20]. This parameter will be enabled only when the following conditions are fulfilled. <ul style="list-style-type: none"> ▪ "Gain adjustment mode selection" in [Pr. PA08] is "Manual mode (___3)". ▪ "Vibration suppression control 1 tuning mode selection" in [Pr. PB02] is "Manual setting (___2)". ▪ "Gain switching selection" in [Pr. PB26] is "Input device (gain switching (CDP)) (___1)". Switching during driving may cause a shock. Be sure to switch them after the servo motor stops. Setting range: 0.0 to 300.0	0.0





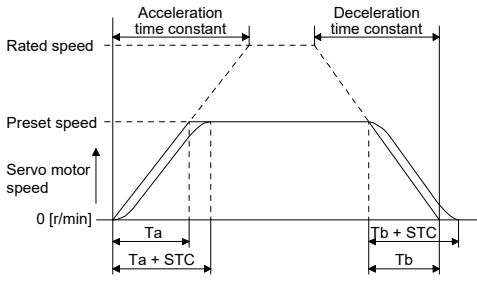

Part 6: Review on Replacement of MR-J3-_T_(DIO command/ Serial communication operation) with MR-J4-_A_-RJ

MR-J3-_T_			MR-J4-_A_-RJ		
No.	Name and function	Initial value	No.	Name and function	Initial value
PC02	Home position return type Used to set the home position return system. 0 0 0 x: Home position return system 0: Dog type 1: Count type 2: Data setting type 3: Stopper type 4: Home position ignorance (Servo-on position as home position) 5: Dog type rear end reference 6: Count type front end reference 7: Dog cradle type 8: Dog type right-before Z-phase reference 9: Dog type front end reference A: Dogless Z-phase reference	0000h	PT04	Home position return type ___ x: Home position return method 0: Dog type (rear end detection, Z-phase reference)/torque limit changing dog type 1: Count type (front end detection, Z-phase reference) 2: Data set type/torque limit changing data set type 3: Stopper type 4: Home position ignorance (servo-on position as home position) 5: Dog type (rear end detection, rear end reference) 6: Count type (front end detection, front end reference) 7: Dog cradle type 8: Dog type (front end detection, Z-phase reference) 9: Dog type (front end detection, front end reference) A: Dogless type (Z-phase reference)	0h
PC03	Home position return direction Used to set the home position return direction. 0 0 0 x: Home position return direction 0: Address increment direction 1: Address decrement direction	0001h	__ x _: Home position return direction 0: Address increasing direction 1: Address decreasing direction Setting "2" or more to this digit will be recognized as "1: Address decreasing direction".	1h	
			_ x _ _: Home position shift distance multiplication Set a multiplication of [Pr. PT07 Home position shift distance]. 0: × 1 1: × 10 2: × 100 3: × 1000	0h	
			x _ _ _: For manufacturer setting	0h	
PC04	Home position return speed Used to set the servo motor speed for home position return.	500	PT05	Home position return speed Set a servo motor speed at home position return. Setting range: 0 to permissible instantaneous speed	100
PC05	Creep speed Used to set the creep speed after proximity dog detection.	10	PT06	Creep speed Set a creep speed after proximity dog at home position return. Setting range: 0 to permissible instantaneous speed	10
PC06	Home position shift distance Used to set the shift distance starting at the Z-phase pulse detection position inside the encoder.	0	PT07	Home position shift distance Set a shift distance from the Z-phase pulse detection position in the encoder. Setting range: 0 to 65535	0
PC07	Home position return position data Used to set the current position on completion of home position return.	0	PT08	Home position return position data Set a current position at home position return completion. Additionally, when the following parameters are changed, the home position return position data will be changed. Execute the home position return again. <ul style="list-style-type: none"> ▪ "Position data unit" in [Pr. PT01] ▪ "Feed length multiplication (STM)" in [Pr. PT03] ▪ "Home position return type" in [Pr. PT04] Setting range: -32768 to 32767	0
PC08	Moving distance after proximity dog Used to set the moving distance after proximity dog in count type home position return.	1000	PT09	Travel distance after proximity dog Set a travel distance after proximity dog at home position return for the count type, dog type rear end reference, count type front end reference, and dog type front end reference. Setting range: 0 to 65535	1000

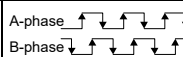
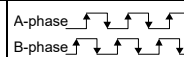
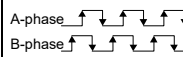
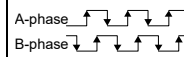
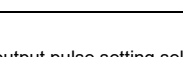
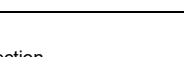
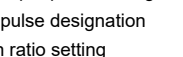
MR-J3-_T_			MR-J4-_A_-RJ		
No.	Name and function	Initial value	No.	Name and function	Initial value
PC09	Stopper type home position return stopper time In stopper type home position return, used to set the time from when the machine part is pressed against the stopper and the torque limit set in [Pr. PC10] is reached to when the home position is set.	100	PT10	Stopper type home position return stopper time Set time from a moving part touches the stopper and torques reaches to the torque limit of [Pr. PT10 Stopper type home position return - Torque limit value] to a home position set for the stopper type home position return. Setting range: 0 to 1000	100
PC10	Stopper type home position return torque limit Used to set the torque limit value relative to the max. torque in [%] in stopper type home position return.	15.0	PT11	Stopper type home position return torque limit value Set a torque limit value with [%] to the maximum torque at stopper type home position return. Setting range: 0.0 to 100.0	15.0
PC11	Rough match output range Used to set the command remaining distance range where the rough match (CPO) is output.	0	PT12	Rough match output range Set a range of the command remaining distance which outputs CPO (Rough match). Setting range: 0 to 65535	0
PC12	Jog speed Used to set the jog speed command.	100	PT13	Jog speed Set a JOG speed. Setting range: 0 to permissible instantaneous speed	100
PC13	S-pattern acceleration/deceleration time constant Set when inserting S-pattern time constant into the acceleration/deceleration time constant of the point table. This time constant is invalid for home position return.	0	PC03	S-pattern acceleration/deceleration time constant This enables to start/stop the servo motor smoothly. Set the time of the arc part for S-pattern acceleration/deceleration. Setting "0" will make it linear acceleration/deceleration. Servo is usually operated with linear acceleration and deceleration; however, smooth start and stop are enabled by setting [Pr. PC03 S-pattern acceleration/deceleration time constants]. When the S-pattern acceleration/deceleration time constants are set, smooth positioning is enabled as shown in the following figure. Note that when it is set, a time period from the start to output of MEND (Travel completion) is longer by the S-pattern acceleration/deceleration time constants.  <p>Ta: Time until preset speed is reached Tb: Time until stop</p> <p>When the STC value is set longer than the constant speed time, the speed may not reach to the command speed. Additionally, when a value of 1000 ms or more is set, it will be clamped to 1000 ms.</p> Setting range: 0 to 5000	0

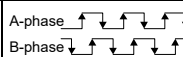
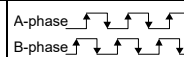
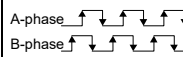
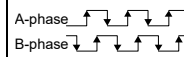
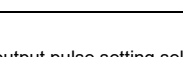
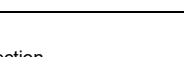
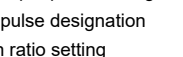
Part 6: Review on Replacement of MR-J3-_T_(DIO command/ Serial communication operation) with MR-J4-_A_-RJ

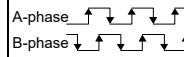
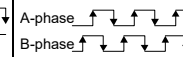
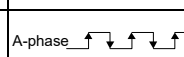
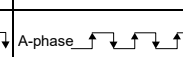
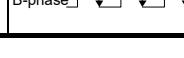
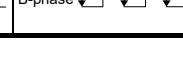
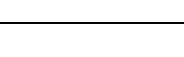
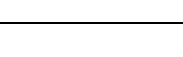
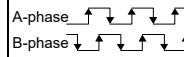
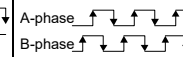
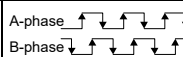
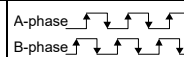
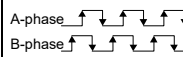
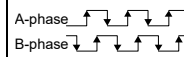
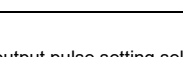
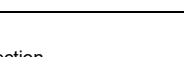
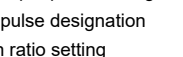
MR-J3-_T_			MR-J4-_A_-RJ			
No.	Name and function	Initial value	No.	Name and function	Initial value	
PC14	<p>Backlash compensation</p> <p>Used to set the backlash compensation made when the command direction is reversed.</p> <p>This function compensates for the number of backlash pulses in the opposite direction to the home position return direction.</p> <p>For the home position ignorance (servo-on position as home position), this function compensates for the number of backlash pulses in the opposite direction to the first rotating direction after establishing the home position by switching ON the servo-on (SON).</p> <p>In the absolute position detection system, this function compensates for the backlash pulse count in the direction opposite to the operating direction at power-on.</p>	0	PT14	<p>Backlash compensation</p> <p>Set a backlash compensation for reversing command direction.</p> <p>This parameter compensates backlash pulses against the home position return direction.</p> <p>For the home position ignorance (servo-on position as home position), this turns on SON (Servo-on) and decides a home position, and compensates backlash pulses against the first rotation direction.</p> <p>Setting range: 0 to 65535</p>	0	
PC16	<p>Electromagnetic brake sequence output</p> <p>Used to set the delay time (Tb) between when the electromagnetic brake interlock (MBR) switches off and when the base circuit is shut off.</p>	100	PC16	<p>Electromagnetic brake sequence output</p> <p>Set the delay time between MBR (Electromagnetic brake interlock) and the base drive circuit is shut-off.</p> <p>Setting range: 0 to 1000</p>	0	
PC17	<p>Zero speed</p> <p>Used to set the output range of the zero speed (ZSP). Zero speed signal detection has hysteresis width of 20 r/min.</p>	50	PC17	<p>Zero speed</p> <p>Set an output range of ZSP (Zero speed detection). ZSP (Zero speed detection) has hysteresis of 20 r/min or 20 mm/s.</p> <p>Setting range: 0 to 10000</p>	50	
PC18	<p>Alarm history clear</p> <p>Used to clear the alarm history.</p>	0000h	PC18	<p>Alarm history clear</p> <p>___x:</p> <p>Alarm history clear selection</p> <p>Used to clear the alarm history.</p> <p>0: Disabled</p> <p>1: Enabled</p> <p>When "Enabled" is set, the alarm history will be cleared at the next power-on. After the alarm history is cleared, the setting is automatically disabled.</p>	0h	
	<p>0 0 0 x:</p> <p>Alarm history clear</p> <p>0: Disabled</p> <p>1: Enabled</p> <p>When alarm history clear is made valid, the alarm history is cleared at next power-on. After the alarm history is cleared, the setting is automatically made invalid (reset to 0).</p>			<p>__x_:</p> <p>For manufacturer setting</p>		0h
				<p>_x_:</p> <p>For manufacturer setting</p>		0h
				<p>x___:</p> <p>For manufacturer setting</p>		0h

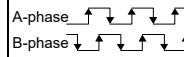
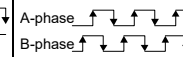
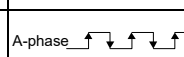
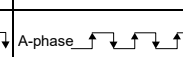
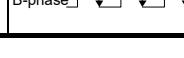
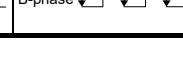
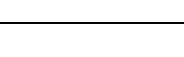
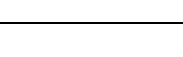
MR-J3-_T_			MR-J4-_A_-RJ																				
No.	Name and function	Initial value	No.	Name and function	Initial value																		
PC19	Encoder output pulse selection Use to select the, encoder output pulse direction and encoder output pulse setting. 0 0 _ x: Encoder output pulse phase changing Changes the phases of A/B-phase encoder pulses output .	0000h	PC19	Encoder output pulse selection _ _ _ x: Encoder output pulse phase selection Select an encoder pulse direction. 0: Increasing A-phase 90° in CCW 1: Increasing A-phase 90° in CW	0h																		
	<table border="1"> <thead> <tr> <th rowspan="2">Set value</th> <th colspan="2">Servo motor rotation direction</th> </tr> <tr> <th>CCW</th> <th>CW</th> </tr> </thead> <tbody> <tr> <td>0</td> <td>A-phase  B-phase </td> <td>A-phase  B-phase </td> </tr> <tr> <td>1</td> <td>A-phase  B-phase </td> <td>A-phase  B-phase </td> </tr> </tbody> </table>			Set value		Servo motor rotation direction		CCW	CW	0	A-phase  B-phase 	A-phase  B-phase 	1	A-phase  B-phase 	A-phase  B-phase 	<table border="1"> <thead> <tr> <th rowspan="2">Setting value</th> <th colspan="2">Servo motor rotation direction</th> </tr> <tr> <th>CCW</th> <th>CW</th> </tr> </thead> <tbody> <tr> <td>0</td> <td>A-phase  B-phase </td> <td>A-phase  B-phase </td> </tr> <tr> <td>1</td> <td>A-phase  B-phase </td> <td>A-phase  B-phase </td> </tr> </tbody> </table>	Setting value	Servo motor rotation direction		CCW	CW	0	A-phase  B-phase 
Set value	Servo motor rotation direction																						
	CCW	CW																					
0	A-phase  B-phase 	A-phase  B-phase 																					
1	A-phase  B-phase 	A-phase  B-phase 																					
Setting value	Servo motor rotation direction																						
	CCW	CW																					
0	A-phase  B-phase 	A-phase  B-phase 																					
1	A-phase  B-phase 	A-phase  B-phase 																					
	0 0 x _: Encoder output pulse setting selection 0: Output pulse designation 1: Division ratio setting 2: Ratio is automatically set to command pulse unit Setting "2" makes the [Pr. PA15] (encoder output pulse) setting invalid.			_ _ x _: Encoder output pulse setting selection 0: Output pulse setting 1: Division ratio setting 2: The same output pulse setting as command pulse 3: A-phase/B-phase pulse electronic gear setting 4: A/B-phase pulse through output setting 5: Command pulse input through output setting When you select "1", the settings of [Pr. PA16 Encoder output pulses 2] will be disabled. When you select "2", the settings of [Pr. PA15 Encoder output pulses] and [Pr. PA16 Encoder output pulses 2] will be disabled. Setting "4" will be enabled only when A/B/Z-phase differential output linear encoder is used. And "Encoder output pulse phase selection (_ _ _ x)" will be disabled. When another encoder is connected, [AL. 37 Parameter error] will occur. Setting "Standard control mode (_ _ 0 _)" in [Pr. PA01] will trigger [AL. 37]. When "5" is set, the settings of [Pr. PA15 Encoder output pulses] and [Pr. PA16 Encoder output pulses 2] will be disabled. "Encoder output pulse phase selection (_ _ _ x)" and "Encoder selection for encoder output pulse (_ x _ _)" will be also disabled. When [Pr. PA01] is set to other than "Point table method (_ _ _ 6)", [AL. 37] occurs. When "5" is set, assign PP/PP2 with [Pr. PD44] and NP/NP2 with [Pr. PD46].	0h																		
				_ x _ _: Selection of the encoders for encoder output pulse Select an encoder used the encoder output pulses which the servo amplifier outputs. 0: Servo motor encoder 1: Load-side encoder When " _ 1 0 _" is set to this parameter, [AL. 37] will occur.	0h																		
				x _ _ _: For manufacturer setting	0h																		
PC20	Station number setting Used to specify the station number for RS-422 serial communication. Always set one station to one axis of servo amplifier. If one station number is set to two or more stations, normal communication cannot be made.	0	PC20	Station No. setting Specify a station No. of the servo amplifier for RS-422 and USB communication. Always set one station to one axis of the servo amplifier. Setting one station number to two or more stations will disable a normal communication. Setting range: 0 to 31	0																		

Part 6: Review on Replacement of MR-J3-_T_(DIO command/ Serial communication operation) with MR-J4-_A_-RJ

MR-J3-_T_			MR-J4-_A_-RJ			
No.	Name and function	Initial value	No.	Name and function	Initial value	
PC21	RS-422 communication function selection Select the communication I/F and select the RS-422 communication conditions.	0000h	PC21	RS-422 communication function selection Select the details of RS-422 communication function.		
	0_ x 0: RS-422 communication baud rate selection 0: 9600 [bps] 1: 19200 [bps] 2: 38400 [bps] 3: 57600 [bps] 4: 115200 [bps]			___ x: For manufacturer setting		0h
	0 x _ 0: RS-422 communication response delay time 0: Disabled 1: Enabled, reply sent after delay time of 800 μs or more			__ x _: RS-422 communication baud rate selection When using the parameter unit, set "1 ___" in [Pr. PF34]. 0: 9600 [bps] 1: 19200 [bps] 2: 38400 [bps] 3: 57600 [bps] 4: 115200 [bps]		0h
PC22	Function selection C-1 Select the encoder cable communication system selection.	0000h	PC22	Function selection C-1		
	x 0 0 0: Encoder cable communication system selection 0: Two-wire type 1: Four-wire type Incorrect setting will result in an encoder alarm [AL.16 Encoder error 1] or [AL.20 Encoder error 2].			___ x: For manufacturer setting		0h
				__ x _: For manufacturer setting		0h
PC24	Function selection C-3 Select the unit of the in-position range.	0000h	PC24	Function selection C-3		
	0 0 0 x: In-position range unit selection 0: Command input unit 1: Servo motor encoder unit			_ x _: For manufacturer setting		0h
				x ___: Error excessive alarm level unit selection Select a setting unit of the error excessive alarm level set in [Pr. PC43]. 0: Per 1 rev or 1 mm 1: Per 0.1 rev or 0.1 mm 2: Per 0.01 rev or 0.01 mm 3: Per 0.001 rev or 0.001 mm		0h

MR-J3-_T_			MR-J4-_A_-RJ																																														
No.	Name and function	Initial value	No.	Name and function	Initial value																																												
PC26	Function selection C-5 Select the [AL. 99 Stroke limit warning].	0000h	PC26	Function selection C-5	0h																																												
	0 0 0 x: [AL. 99 Stroke limit warning] selection 0: Enabled 1: Disabled When this parameter is set to "1", A99 will not occur if the forward rotation stroke end (LSP) or reverse rotation stroke end (LSN) turns OFF.			__ _ x: [AL. 99 Stroke limit warning] selection Enable or disable [AL. 99 Stroke limit warning]. 0: Enabled 1: Disabled																																													
PC27	Function selection C-6 Set this function if undervoltage alarm occurs because of distorted power supply voltage waveform when using power regenerative converter or power regenerative common converter.	0000h	PC27	Function selection C-6	0h																																												
	0 0 0 x: Setting when undervoltage alarm occurs 0: Initial value 1: Set "1" if undervoltage alarm occurs because of distorted power supply voltage waveform when using power regenerative converter or power regenerative common converter.			__ _ x: [AL. 10 Undervoltage] detection method selection Set this parameter when [AL. 10 Undervoltage] occurs due to distorted power supply voltage waveform while using FR-RC-(H) or FR-CV-(H). 0: [AL. 10] not occurrence 1: [AL. 10] occurrence																																													
PC28	Function selection Select the display method of the current position and command position.	0000h	PT26	Function selection T-2	0h																																												
	0 0 _ x: Electronic gear fraction clear selection 0: Disabled 1: Enabled By setting it to "1" the fraction of the last command by the electronic gear is cleared when starting automatic operation.			__ _ x: Electronic gear fraction clear selection 0: Disabled 1: Enabled Selecting "Enabled" will clear a fraction of the previous command by the electronic gear at start of the automatic operation. Setting "2" or more to this digit will be "Disabled".																																													
	0 0 x _: Current position/command position selection			__ _ x _: Current position/command position display selection Select how to display a current position and command position.	0h																																												
	<table border="1"> <thead> <tr> <th rowspan="2">Set value</th> <th rowspan="2">Display method</th> <th rowspan="2">Operation mode</th> <th colspan="2">Status display description</th> </tr> <tr> <th>Current position</th> <th>Command position</th> </tr> </thead> <tbody> <tr> <td rowspan="2">0</td> <td rowspan="2">Positioning display</td> <td>Automatic</td> <td>The actual current position where the machine home position is assumed as 0 is displayed.</td> <td>The command current position where the machine home position is assumed as 0 is displayed.</td> </tr> <tr> <td>Manual</td> <td></td> <td></td> </tr> <tr> <td rowspan="2">1</td> <td rowspan="2">Roll feed display</td> <td>Automatic</td> <td>The actual current position where the Automatic operation start position is assumed as 0 is displayed.</td> <td>The count starts from 0 when the start signal is turned ON, and the command current position to the target position is displayed. During a stop, the command position of the selected point table is displayed.</td> </tr> <tr> <td>Manual</td> <td></td> <td>The command position of the selected point table is displayed.</td> </tr> </tbody> </table>	Set value	Display method	Operation mode	Status display description		Current position	Command position	0	Positioning display	Automatic	The actual current position where the machine home position is assumed as 0 is displayed.	The command current position where the machine home position is assumed as 0 is displayed.	Manual			1	Roll feed display	Automatic	The actual current position where the Automatic operation start position is assumed as 0 is displayed.	The count starts from 0 when the start signal is turned ON, and the command current position to the target position is displayed. During a stop, the command position of the selected point table is displayed.	Manual		The command position of the selected point table is displayed.			<table border="1"> <thead> <tr> <th rowspan="2">Setting value</th> <th rowspan="2">Displayed data</th> <th rowspan="2">Operation mode</th> <th colspan="2">Status display</th> </tr> <tr> <th>Current position</th> <th>Command position</th> </tr> </thead> <tbody> <tr> <td>__ 0 _</td> <td>Positioning display</td> <td>Auto/Manual</td> <td>Actual current position will be displayed as machine home position is 0.</td> <td>Command current position will be displayed as machine home position is 0.</td> </tr> <tr> <td>__ 1 _</td> <td>Roll feed display</td> <td>Auto</td> <td>Actual current position will be displayed as automatic operation start position is 0.</td> <td>When ST1 (Forward rotation start) or ST2 (Reverse rotation start) is turned on, counting starts from 0 and a command current position to the target position will be displayed. When a stop, a point table command position for the point table method will be displayed.</td> </tr> <tr> <td></td> <td></td> <td>Manual</td> <td></td> <td>0 will be continuously displayed.</td> </tr> </tbody> </table>	Setting value	Displayed data	Operation mode	Status display		Current position	Command position	__ 0 _	Positioning display	Auto/Manual	Actual current position will be displayed as machine home position is 0.	Command current position will be displayed as machine home position is 0.	__ 1 _	Roll feed display	Auto	Actual current position will be displayed as automatic operation start position is 0.	When ST1 (Forward rotation start) or ST2 (Reverse rotation start) is turned on, counting starts from 0 and a command current position to the target position will be displayed. When a stop, a point table command position for the point table method will be displayed.			Manual		0 will be continuously displayed.
Set value	Display method				Operation mode	Status display description																																											
		Current position	Command position																																														
0	Positioning display	Automatic	The actual current position where the machine home position is assumed as 0 is displayed.	The command current position where the machine home position is assumed as 0 is displayed.																																													
		Manual																																															
1	Roll feed display	Automatic	The actual current position where the Automatic operation start position is assumed as 0 is displayed.	The count starts from 0 when the start signal is turned ON, and the command current position to the target position is displayed. During a stop, the command position of the selected point table is displayed.																																													
		Manual		The command position of the selected point table is displayed.																																													
Setting value	Displayed data	Operation mode	Status display																																														
			Current position	Command position																																													
__ 0 _	Positioning display	Auto/Manual	Actual current position will be displayed as machine home position is 0.	Command current position will be displayed as machine home position is 0.																																													
__ 1 _	Roll feed display	Auto	Actual current position will be displayed as automatic operation start position is 0.	When ST1 (Forward rotation start) or ST2 (Reverse rotation start) is turned on, counting starts from 0 and a command current position to the target position will be displayed. When a stop, a point table command position for the point table method will be displayed.																																													
		Manual		0 will be continuously displayed.																																													
				_ x _ _: For manufacturer setting	0h																																												
				x _ _ _: For manufacturer setting	0h																																												

MR-J3-_T_			MR-J4-_A_-RJ		
No.	Name and function	Initial value	No.	Name and function	Initial value
PC31	Software limit +	0	PT15	Software limit + (third least significant digit)	0
PC32	Used to set the address increment side software stroke limit. The software limit is made invalid if this value is the same as in "software limit -". Set the same sign to [Pr. PC31] and [Pr. PC32]. Setting of different signs will result in a parameter error. Set address: <div style="text-align: center;"> </div> The software limit+ is a set of upper digits and lower digits. To change the value, set in the order of lower digits to upper digits.		PT16	Software limit + (third most significant digit) Set an address increasing side of the software stroke limit. Upper and lower are a set. Setting address: <div style="text-align: center;"> </div> The stop method depends on "Stop method selection at software limit detection" of [Pr. PD30]. The initial value is "Quick stop (home position erased)". Setting a same value with "Software limit -" will disable the software stroke limit. Set a same sign for [Pr. PT15] and [Pr. PT16]. A different sign will be recognized as minus sign data. When changing the direction to address decreasing, change it from the - side of the software limit ([Pr. PT17] and [Pr. PT18]). An incorrect order of the setting will trigger [AL. 37 Parameter error]. Therefore, cycling power may be required after [Pr. PT15] to [Pr. PT18] are all set. Setting range: -999999 to 999999	
PC33	Software limit -	0	PT17	Software limit - (third least significant digit)	0
PC34	Used to set the address decrement side software stroke limit. The software limit is made invalid if this value is the same as in "software limit+". Set the same sign to [Pr. PC33] and [Pr. PC34]. Setting of different signs will result in a parameter error. Set address: <div style="text-align: center;"> </div> The software limit- is a set of upper digits and lower digits. To change the value, set in the order of lower digits to upper digits.		PT18	Software limit - (third most significant digit) Set an address decreasing side of the software stroke limit. Upper and lower are a set. Setting address: <div style="text-align: center;"> </div> The stop method depends on "Stop method selection at software limit detection" of [Pr. PD30]. The initial value is "Quick stop (home position erased)". Setting a same value with "Software limit +" will disable the software stroke limit. Set a same sign for [Pr. PT17] and [Pr. PT18]. A different sign will be recognized as minus sign data. When changing the direction to the address increasing direction, change it from the + side of the software limit ([Pr. PT15] and [Pr. PT16]). An incorrect order of the setting will trigger [AL. 37 Parameter error]. Therefore, cycling power may be required after [Pr. PT15] to [Pr. PT18] are all set. Setting range: -999999 to 999999	
PC35	Internal torque limit 2 Set this parameter to limit servo motor torque on the assumption that the maximum torque is 100[%]. When 0 is set, torque is not produced.	100.0	PC35	Internal torque limit 2 Set the parameter on the assumption that the maximum torque 100.0 %. The parameter is set for limiting the torque of the servo motor . No torque is generated when this parameter is set to "0.0". When TL1 (Internal torque limit selection) is turned on, Internal torque limit 1 and Internal torque limit 2 are compared and the lower value will be enabled. Set the parameter referring to section 3.6.1 (5) of "MR-J4-_A_-RJ/MR-J4-03A6(-RJ) Servo Amplifier Instruction Manual". Setting range: 0.0 to 100.0	100.0

Part 6: Review on Replacement of MR-J3-_T_(DIO command/ Serial communication operation) with MR-J4-_A_-RJ

MR-J3-_T_			MR-J4-_A_-RJ		
No.	Name and function	Initial value	No.	Name and function	Initial value
PC36	Status display selection Select the status display to be provided at power-on. x x 0 0: Selection of MR-DP60 status display at power-on 0 0: Current position 0 1: Command position 0 2: Command remaining distance 0 3: Point table No. 0 4: Cumulative feedback pulses 0 5: Servo motor speed 0 6: Droop pulses 0 7: Override voltage 0 8: Override [%] 0 9: Analog speed command voltage 0 A: Regenerative load ratio 0 B: Effective load ratio 0 C: Peak load ratio 0 D: Instantaneous torque 0 E: Within one-revolution position 0 F: ABS counter 1 0: Load inertia moment ratio 1 1: Bus voltage	0000h	PC36	Status display selection __ x x: Status display selection at power-on Select a status display shown at power-on. 00: Cumulative feedback pulse 01: Servo motor speed 02: Droop pulses 03: Cumulative command pulses 04: Command pulse frequency 05: Analog speed command voltage (not used for the positioning mode) 06: Analog torque limit voltage 07: Regenerative load ratio 08: Effective load ratio 09: Peak load ratio 0A: Instantaneous torque 0B: Position within one-revolution/virtual position within one-revolution (1 pulse unit) 0C: Position within one-revolution/virtual position within one-revolution (1000 pulses unit) 0D: ABS counter/virtual ABS counter 0E: Load to motor inertia ratio/load to motor mass ratio 0F: Bus voltage 21: Current position 22: Command position 23: Command remaining distance 24: Point table No. 26: Override voltage 27: Override level	00h

MR-J3-_T_			MR-J4-_A_-RJ		
No.	Name and function	Initial value	No.	Name and function	Initial value
PC37 PC38	<p>Position range output address+</p> <p>Used to set the address increment side position range output address. the same sign to [Pr. PC37] and [Pr. PC38]. Setting of different signs will result in a parameter error. In [Pr. PC37] to [Pr. PC40], set the range where position range (POT) turns on.</p> <p>Set address:</p> <div style="text-align: center;"> </div> <p>Position range output address+ is a set of upper digits and lower digits. To change the value, set in the order of lower digits to upper digits.</p>	0	PT19 PT20	<p>Position range output address + (third least significant digit)</p> <p>Position range output address + (third most significant digit)</p> <p>Set an address increasing side of the position range output address. Upper and lower are a set. Set a range which POT (Position range) turns on with [Pr. PT19] to [Pr. PT22].</p> <p>Setting address:</p> <div style="text-align: center;"> </div> <p>Set a same sign for [Pr. PT19] and [Pr. PT20]. Setting a different sign will trigger [AL. 37 Parameter error]. When changing a setting, always set the third least significant digit before setting the third most significant digit. When changing the direction to address decreasing, change it from the - side of the position range output address ([Pr. PT21] and [Pr. PT22]). An incorrect order of the setting will trigger [AL. 37]. Therefore, cycling power may be required after [Pr. PT19] to [Pr. PT22] are all set.</p> <p>Setting range: -999999 to 999999</p>	0
PC39 PC40	<p>Position range output address -</p> <p>Used to set the address decrement side position range output address. Set the same sign to [Pr. PC39] and [Pr. PC40]. Setting of different signs will result in a parameter error.</p> <p>Set address:</p> <div style="text-align: center;"> </div> <p>Position range output address - is a set of upper digits and lower digits. To change the value, set in the order of lower digits to upper digits.</p>	0	PT21 PT22	<p>Position range output address - (third least significant digit)</p> <p>Position range output address - (third most significant digit)</p> <p>Set an address decreasing side of the position range output address. Upper and lower are a set. Set a range which POT (Position range) turns on with [Pr. PT19] to [Pr. PT22].</p> <p>Setting address:</p> <div style="text-align: center;"> </div> <p>Set a same sign for [Pr. PT21] and [Pr. PT22]. Setting a different sign will trigger [AL. 37 Parameter error]. When changing a setting, always set the third least significant digit before setting the third most significant digit. When changing the direction to address increasing, change it from the + side of the position range output address ([Pr. PT19] and [Pr. PT20]). An incorrect order of the setting will trigger [AL. 37]. Therefore, cycling power may be required after [Pr. PT19] to [Pr. PT22] are all set.</p> <p>Setting range: -999999 to 999999</p>	0

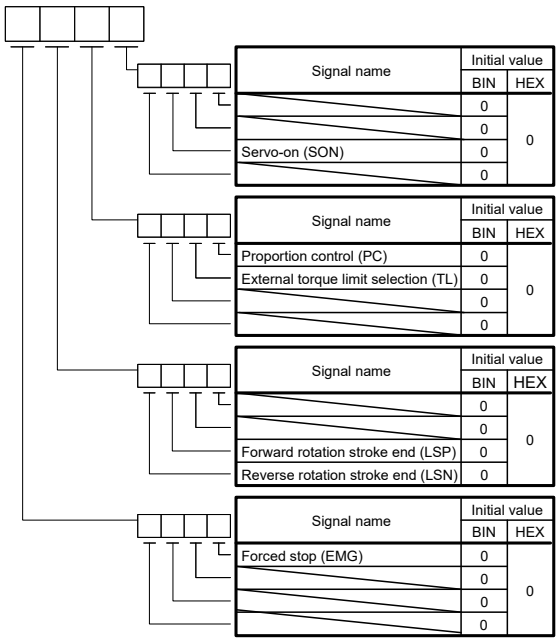
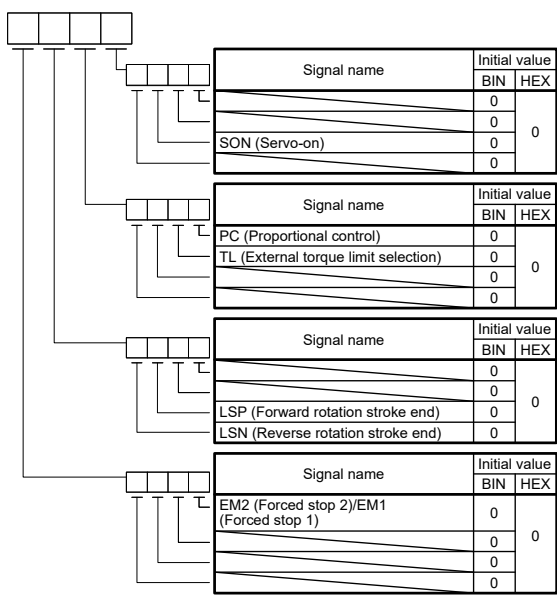
MR-J3-_T_			MR-J4-_A_-RJ																																																																																																																																																					
No.	Name and function	Initial value	No.	Name and function	Initial value																																																																																																																																																			
PD01	<p>Input signal automatic ON selection 1</p> <p>Select the input devices to be automatically turned ON.</p> <p> part is for manufacturer setting. Do not set the value by any means.</p>  <table border="1" data-bbox="462 504 790 638"> <thead> <tr> <th rowspan="2">Signal name</th> <th colspan="2">Initial value</th> </tr> <tr> <th>BIN</th> <th>HEX</th> </tr> </thead> <tbody> <tr> <td>Servo-on (SON)</td> <td>0</td> <td rowspan="4">0</td> </tr> <tr> <td>Proportion control (PC)</td> <td>0</td> </tr> <tr> <td>External torque limit selection (TL)</td> <td>0</td> </tr> <tr> <td>Reverse rotation stroke end (LSN)</td> <td>0</td> </tr> </tbody> </table> <table border="1" data-bbox="462 660 790 795"> <thead> <tr> <th rowspan="2">Signal name</th> <th colspan="2">Initial value</th> </tr> <tr> <th>BIN</th> <th>HEX</th> </tr> </thead> <tbody> <tr> <td>Proportion control (PC)</td> <td>0</td> <td rowspan="4">0</td> </tr> <tr> <td>External torque limit selection (TL)</td> <td>0</td> </tr> <tr> <td>Forward rotation stroke end (LSP)</td> <td>0</td> </tr> <tr> <td>Reverse rotation stroke end (LSN)</td> <td>0</td> </tr> </tbody> </table> <table border="1" data-bbox="462 817 790 952"> <thead> <tr> <th rowspan="2">Signal name</th> <th colspan="2">Initial value</th> </tr> <tr> <th>BIN</th> <th>HEX</th> </tr> </thead> <tbody> <tr> <td>Forward rotation stroke end (LSP)</td> <td>0</td> <td rowspan="4">0</td> </tr> <tr> <td>Reverse rotation stroke end (LSN)</td> <td>0</td> </tr> <tr> <td>Forced stop (EMG)</td> <td>0</td> </tr> <tr> <td>Forced stop (EMG)</td> <td>0</td> </tr> </tbody> </table> <table border="1" data-bbox="462 974 790 1097"> <thead> <tr> <th rowspan="2">Signal name</th> <th colspan="2">Initial value</th> </tr> <tr> <th>BIN</th> <th>HEX</th> </tr> </thead> <tbody> <tr> <td>Forced stop (EMG)</td> <td>0</td> <td rowspan="4">0</td> </tr> <tr> <td>Forced stop (EMG)</td> <td>0</td> </tr> <tr> <td>Forced stop (EMG)</td> <td>0</td> </tr> <tr> <td>Forced stop (EMG)</td> <td>0</td> </tr> </tbody> </table> <p>BIN 0: Used to external input signal. BIN 1: Automatic ON</p> <p>For example, to turn ON SON, the setting is "___4".</p>	Signal name	Initial value		BIN	HEX	Servo-on (SON)	0	0	Proportion control (PC)	0	External torque limit selection (TL)	0	Reverse rotation stroke end (LSN)	0	Signal name	Initial value		BIN	HEX	Proportion control (PC)	0	0	External torque limit selection (TL)	0	Forward rotation stroke end (LSP)	0	Reverse rotation stroke end (LSN)	0	Signal name	Initial value		BIN	HEX	Forward rotation stroke end (LSP)	0	0	Reverse rotation stroke end (LSN)	0	Forced stop (EMG)	0	Forced stop (EMG)	0	Signal name	Initial value		BIN	HEX	Forced stop (EMG)	0	0	Forced stop (EMG)	0	Forced stop (EMG)	0	Forced stop (EMG)	0	0000h	PD01	<p>Input signal automatic on selection 1</p> <p>Convert the setting value into hexadecimal as follows.</p> <table border="1" data-bbox="877 369 1364 548"> <thead> <tr> <th>___x (HEX)</th> <th>___x (BIN): For manufacturer setting</th> <th rowspan="4">0h</th> </tr> </thead> <tbody> <tr> <td>___x</td> <td>___x (BIN): For manufacturer setting</td> </tr> <tr> <td>_x__</td> <td>SON (Servo-on)</td> </tr> <tr> <td>x___</td> <td>For manufacturer setting</td> </tr> </tbody> </table> <table border="1" data-bbox="877 560 1364 817"> <thead> <tr> <th>__x_ (HEX)</th> <th>___x (BIN): PC (Proportional control)</th> <th rowspan="4">0h</th> </tr> </thead> <tbody> <tr> <td>__x_</td> <td>TL (External torque limit selection)</td> </tr> <tr> <td>_x__</td> <td>For manufacturer setting</td> </tr> <tr> <td>x___</td> <td>For manufacturer setting</td> </tr> </tbody> </table> <table border="1" data-bbox="877 828 1364 1108"> <thead> <tr> <th>_x__ (HEX)</th> <th>___x (BIN): For manufacturer setting</th> <th rowspan="4">0h</th> </tr> </thead> <tbody> <tr> <td>_x__</td> <td>LSP (Forward rotation stroke end)</td> </tr> <tr> <td>x___</td> <td>LSN (Reverse rotation stroke end)</td> </tr> <tr> <td>x___</td> <td>For manufacturer setting</td> </tr> </tbody> </table> <table border="1" data-bbox="877 1120 1364 1321"> <thead> <tr> <th>x___ (HEX)</th> <th>___x (BIN): EM2 (Forced stop 2)/EM1 (Forced stop 1)</th> <th rowspan="4">0h</th> </tr> </thead> <tbody> <tr> <td>x___</td> <td>For manufacturer setting</td> </tr> <tr> <td>x___</td> <td>For manufacturer setting</td> </tr> <tr> <td>x___</td> <td>For manufacturer setting</td> </tr> </tbody> </table> <p>Convert the setting value into hexadecimal as follows.</p>  <table border="1" data-bbox="1085 1400 1436 1534"> <thead> <tr> <th rowspan="2">Signal name</th> <th colspan="2">Initial value</th> </tr> <tr> <th>BIN</th> <th>HEX</th> </tr> </thead> <tbody> <tr> <td>SON (Servo-on)</td> <td>0</td> <td rowspan="4">0</td> </tr> <tr> <td>PC (Proportional control)</td> <td>0</td> </tr> <tr> <td>TL (External torque limit selection)</td> <td>0</td> </tr> <tr> <td>Reverse rotation stroke end (LSN)</td> <td>0</td> </tr> </tbody> </table> <table border="1" data-bbox="1085 1545 1436 1668"> <thead> <tr> <th rowspan="2">Signal name</th> <th colspan="2">Initial value</th> </tr> <tr> <th>BIN</th> <th>HEX</th> </tr> </thead> <tbody> <tr> <td>PC (Proportional control)</td> <td>0</td> <td rowspan="4">0</td> </tr> <tr> <td>TL (External torque limit selection)</td> <td>0</td> </tr> <tr> <td>Forward rotation stroke end (LSP)</td> <td>0</td> </tr> <tr> <td>Reverse rotation stroke end (LSN)</td> <td>0</td> </tr> </tbody> </table> <table border="1" data-bbox="1085 1680 1436 1803"> <thead> <tr> <th rowspan="2">Signal name</th> <th colspan="2">Initial value</th> </tr> <tr> <th>BIN</th> <th>HEX</th> </tr> </thead> <tbody> <tr> <td>LSP (Forward rotation stroke end)</td> <td>0</td> <td rowspan="4">0</td> </tr> <tr> <td>LSN (Reverse rotation stroke end)</td> <td>0</td> </tr> <tr> <td>EM2 (Forced stop 2)/EM1 (Forced stop 1)</td> <td>0</td> </tr> <tr> <td>EM2 (Forced stop 2)/EM1 (Forced stop 1)</td> <td>0</td> </tr> </tbody> </table> <table border="1" data-bbox="1085 1814 1436 1937"> <thead> <tr> <th rowspan="2">Signal name</th> <th colspan="2">Initial value</th> </tr> <tr> <th>BIN</th> <th>HEX</th> </tr> </thead> <tbody> <tr> <td>EM2 (Forced stop 2)/EM1 (Forced stop 1)</td> <td>0</td> <td rowspan="4">0</td> </tr> <tr> <td>EM2 (Forced stop 2)/EM1 (Forced stop 1)</td> <td>0</td> </tr> <tr> <td>EM2 (Forced stop 2)/EM1 (Forced stop 1)</td> <td>0</td> </tr> <tr> <td>EM2 (Forced stop 2)/EM1 (Forced stop 1)</td> <td>0</td> </tr> </tbody> </table> <p>BIN 0: Use for an external input signal. BIN 1: Automatic on</p>	___x (HEX)	___x (BIN): For manufacturer setting	0h	___x	___x (BIN): For manufacturer setting	_x__	SON (Servo-on)	x___	For manufacturer setting	__x_ (HEX)	___x (BIN): PC (Proportional control)	0h	__x_	TL (External torque limit selection)	_x__	For manufacturer setting	x___	For manufacturer setting	_x__ (HEX)	___x (BIN): For manufacturer setting	0h	_x__	LSP (Forward rotation stroke end)	x___	LSN (Reverse rotation stroke end)	x___	For manufacturer setting	x___ (HEX)	___x (BIN): EM2 (Forced stop 2)/EM1 (Forced stop 1)	0h	x___	For manufacturer setting	x___	For manufacturer setting	x___	For manufacturer setting	Signal name	Initial value		BIN	HEX	SON (Servo-on)	0	0	PC (Proportional control)	0	TL (External torque limit selection)	0	Reverse rotation stroke end (LSN)	0	Signal name	Initial value		BIN	HEX	PC (Proportional control)	0	0	TL (External torque limit selection)	0	Forward rotation stroke end (LSP)	0	Reverse rotation stroke end (LSN)	0	Signal name	Initial value		BIN	HEX	LSP (Forward rotation stroke end)	0	0	LSN (Reverse rotation stroke end)	0	EM2 (Forced stop 2)/EM1 (Forced stop 1)	0	EM2 (Forced stop 2)/EM1 (Forced stop 1)	0	Signal name	Initial value		BIN	HEX	EM2 (Forced stop 2)/EM1 (Forced stop 1)	0	0	EM2 (Forced stop 2)/EM1 (Forced stop 1)	0	EM2 (Forced stop 2)/EM1 (Forced stop 1)	0	EM2 (Forced stop 2)/EM1 (Forced stop 1)	0
Signal name	Initial value																																																																																																																																																							
	BIN	HEX																																																																																																																																																						
Servo-on (SON)	0	0																																																																																																																																																						
Proportion control (PC)	0																																																																																																																																																							
External torque limit selection (TL)	0																																																																																																																																																							
Reverse rotation stroke end (LSN)	0																																																																																																																																																							
Signal name	Initial value																																																																																																																																																							
	BIN	HEX																																																																																																																																																						
Proportion control (PC)	0	0																																																																																																																																																						
External torque limit selection (TL)	0																																																																																																																																																							
Forward rotation stroke end (LSP)	0																																																																																																																																																							
Reverse rotation stroke end (LSN)	0																																																																																																																																																							
Signal name	Initial value																																																																																																																																																							
	BIN	HEX																																																																																																																																																						
Forward rotation stroke end (LSP)	0	0																																																																																																																																																						
Reverse rotation stroke end (LSN)	0																																																																																																																																																							
Forced stop (EMG)	0																																																																																																																																																							
Forced stop (EMG)	0																																																																																																																																																							
Signal name	Initial value																																																																																																																																																							
	BIN	HEX																																																																																																																																																						
Forced stop (EMG)	0	0																																																																																																																																																						
Forced stop (EMG)	0																																																																																																																																																							
Forced stop (EMG)	0																																																																																																																																																							
Forced stop (EMG)	0																																																																																																																																																							
___x (HEX)	___x (BIN): For manufacturer setting	0h																																																																																																																																																						
___x	___x (BIN): For manufacturer setting																																																																																																																																																							
_x__	SON (Servo-on)																																																																																																																																																							
x___	For manufacturer setting																																																																																																																																																							
__x_ (HEX)	___x (BIN): PC (Proportional control)	0h																																																																																																																																																						
__x_	TL (External torque limit selection)																																																																																																																																																							
_x__	For manufacturer setting																																																																																																																																																							
x___	For manufacturer setting																																																																																																																																																							
_x__ (HEX)	___x (BIN): For manufacturer setting	0h																																																																																																																																																						
_x__	LSP (Forward rotation stroke end)																																																																																																																																																							
x___	LSN (Reverse rotation stroke end)																																																																																																																																																							
x___	For manufacturer setting																																																																																																																																																							
x___ (HEX)	___x (BIN): EM2 (Forced stop 2)/EM1 (Forced stop 1)	0h																																																																																																																																																						
x___	For manufacturer setting																																																																																																																																																							
x___	For manufacturer setting																																																																																																																																																							
x___	For manufacturer setting																																																																																																																																																							
Signal name	Initial value																																																																																																																																																							
	BIN	HEX																																																																																																																																																						
SON (Servo-on)	0	0																																																																																																																																																						
PC (Proportional control)	0																																																																																																																																																							
TL (External torque limit selection)	0																																																																																																																																																							
Reverse rotation stroke end (LSN)	0																																																																																																																																																							
Signal name	Initial value																																																																																																																																																							
	BIN	HEX																																																																																																																																																						
PC (Proportional control)	0	0																																																																																																																																																						
TL (External torque limit selection)	0																																																																																																																																																							
Forward rotation stroke end (LSP)	0																																																																																																																																																							
Reverse rotation stroke end (LSN)	0																																																																																																																																																							
Signal name	Initial value																																																																																																																																																							
	BIN	HEX																																																																																																																																																						
LSP (Forward rotation stroke end)	0	0																																																																																																																																																						
LSN (Reverse rotation stroke end)	0																																																																																																																																																							
EM2 (Forced stop 2)/EM1 (Forced stop 1)	0																																																																																																																																																							
EM2 (Forced stop 2)/EM1 (Forced stop 1)	0																																																																																																																																																							
Signal name	Initial value																																																																																																																																																							
	BIN	HEX																																																																																																																																																						
EM2 (Forced stop 2)/EM1 (Forced stop 1)	0	0																																																																																																																																																						
EM2 (Forced stop 2)/EM1 (Forced stop 1)	0																																																																																																																																																							
EM2 (Forced stop 2)/EM1 (Forced stop 1)	0																																																																																																																																																							
EM2 (Forced stop 2)/EM1 (Forced stop 1)	0																																																																																																																																																							

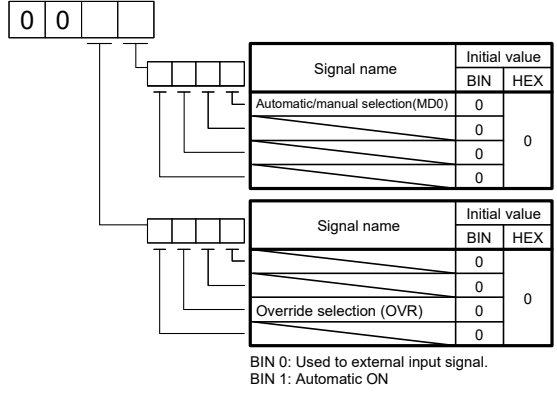
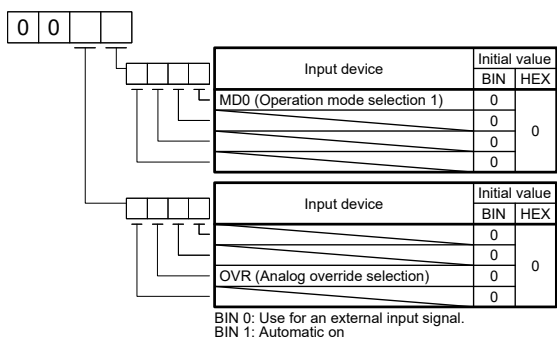
MR-J3-_T_			MR-J4-_A_-RJ																														
No.	Name and function	Initial value	No.	Name and function	Initial value																												
PD03	<p>Input signal automatic ON selection 3</p> <p>Select the input devices to be automatically turned ON.</p> <p><input type="checkbox"/> part is for manufacturer setting. Do not set the value by any means.</p>  <p>BIN 0: Used to external input signal. BIN 1: Automatic ON</p>	0000h	PD41	<p>Input signal automatic on selection 3</p> <p>Select input devices to turn on them automatically.</p> <table border="1"> <tr> <td>___x (HEX)</td> <td>___x (BIN): MD0 (operation mode selection 1) 0: Disabled (Use for an external input signal.) 1: Enabled (automatic on)</td> <td rowspan="3">0h</td> </tr> <tr> <td>___x (BIN): For manufacturer setting</td> <td></td> </tr> <tr> <td>x___ (BIN): For manufacturer setting</td> <td></td> </tr> <tr> <td>__x_ (HEX)</td> <td>__x_ (BIN): For manufacturer setting __x_ (BIN): For manufacturer setting _x__ (BIN): OVR (Analog override selection) 0: Disabled (Use for an external input signal.) 1: Enabled (automatic on)</td> <td rowspan="3">0h</td> </tr> <tr> <td>x___ (BIN): For manufacturer setting</td> <td></td> </tr> <tr> <td>___x (BIN): For manufacturer setting</td> <td></td> </tr> <tr> <td>_x__ (HEX)</td> <td>___x (BIN): For manufacturer setting ___x (BIN): For manufacturer setting _x__ (BIN): For manufacturer setting x___ (BIN): For manufacturer setting</td> <td rowspan="3">0h</td> </tr> <tr> <td>___x (BIN): For manufacturer setting</td> <td></td> </tr> <tr> <td>x___ (BIN): For manufacturer setting</td> <td></td> </tr> <tr> <td>x___ (HEX)</td> <td>___x (BIN): For manufacturer setting ___x (BIN): For manufacturer setting _x__ (BIN): For manufacturer setting x___ (BIN): For manufacturer setting</td> <td rowspan="3">0h</td> </tr> <tr> <td>___x (BIN): For manufacturer setting</td> <td></td> </tr> <tr> <td>x___ (BIN): For manufacturer setting</td> <td></td> </tr> </table> <p>Convert the setting value into hexadecimal as follows.</p>  <p>BIN 0: Use for an external input signal. BIN 1: Automatic on</p>	___x (HEX)	___x (BIN): MD0 (operation mode selection 1) 0: Disabled (Use for an external input signal.) 1: Enabled (automatic on)	0h	___x (BIN): For manufacturer setting		x___ (BIN): For manufacturer setting		__x_ (HEX)	__x_ (BIN): For manufacturer setting __x_ (BIN): For manufacturer setting _x__ (BIN): OVR (Analog override selection) 0: Disabled (Use for an external input signal.) 1: Enabled (automatic on)	0h	x___ (BIN): For manufacturer setting		___x (BIN): For manufacturer setting		_x__ (HEX)	___x (BIN): For manufacturer setting ___x (BIN): For manufacturer setting _x__ (BIN): For manufacturer setting x___ (BIN): For manufacturer setting	0h	___x (BIN): For manufacturer setting		x___ (BIN): For manufacturer setting		x___ (HEX)	___x (BIN): For manufacturer setting ___x (BIN): For manufacturer setting _x__ (BIN): For manufacturer setting x___ (BIN): For manufacturer setting	0h	___x (BIN): For manufacturer setting		x___ (BIN): For manufacturer setting		
___x (HEX)	___x (BIN): MD0 (operation mode selection 1) 0: Disabled (Use for an external input signal.) 1: Enabled (automatic on)	0h																															
___x (BIN): For manufacturer setting																																	
x___ (BIN): For manufacturer setting																																	
__x_ (HEX)	__x_ (BIN): For manufacturer setting __x_ (BIN): For manufacturer setting _x__ (BIN): OVR (Analog override selection) 0: Disabled (Use for an external input signal.) 1: Enabled (automatic on)	0h																															
x___ (BIN): For manufacturer setting																																	
___x (BIN): For manufacturer setting																																	
_x__ (HEX)	___x (BIN): For manufacturer setting ___x (BIN): For manufacturer setting _x__ (BIN): For manufacturer setting x___ (BIN): For manufacturer setting	0h																															
___x (BIN): For manufacturer setting																																	
x___ (BIN): For manufacturer setting																																	
x___ (HEX)	___x (BIN): For manufacturer setting ___x (BIN): For manufacturer setting _x__ (BIN): For manufacturer setting x___ (BIN): For manufacturer setting	0h																															
___x (BIN): For manufacturer setting																																	
x___ (BIN): For manufacturer setting																																	

MR-J3-_T_			MR-J4-_A_ _RJ																																																																				
No.	Name and function	Initial value	No.	Name and function	Initial value																																																																		
PD04	Input signal automatic ON selection 4 Select the input devices to be automatically turned ON.	0000h	PD42	Input signal automatic on selection 4 Select input devices to turn on them automatically.																																																																			
	<table border="1"> <thead> <tr> <th>Signal name</th> <th colspan="2">Initial value</th> </tr> <tr> <th></th> <th>BIN</th> <th>HEX</th> </tr> </thead> <tbody> <tr> <td>Point table No.selection 1 (DI0)</td> <td>0</td> <td rowspan="4">0</td> </tr> <tr> <td>Point table No.selection 2 (DI1)</td> <td>0</td> </tr> <tr> <td>Point table No.selection 3 (DI2)</td> <td>0</td> </tr> <tr> <td>Point table No.selection 4 (DI3)</td> <td>0</td> </tr> </tbody> </table> <table border="1"> <thead> <tr> <th>Signal name</th> <th colspan="2">Initial value</th> </tr> <tr> <th></th> <th>BIN</th> <th>HEX</th> </tr> </thead> <tbody> <tr> <td>Point table No.selection 5 (DI4)</td> <td>0</td> <td rowspan="4">0</td> </tr> <tr> <td>Point table No.selection 6 (DI5)</td> <td>0</td> </tr> <tr> <td>Point table No.selection 7 (DI6)</td> <td>0</td> </tr> <tr> <td>Point table No.selection 8 (DI7)</td> <td>0</td> </tr> </tbody> </table> <p>BIN 0: Used to external input signal. BIN 1: Automatic ON</p>	Signal name	Initial value			BIN	HEX	Point table No.selection 1 (DI0)	0	0	Point table No.selection 2 (DI1)	0	Point table No.selection 3 (DI2)	0	Point table No.selection 4 (DI3)	0	Signal name	Initial value			BIN	HEX	Point table No.selection 5 (DI4)	0	0	Point table No.selection 6 (DI5)	0	Point table No.selection 7 (DI6)	0	Point table No.selection 8 (DI7)	0		<table border="1"> <thead> <tr> <th>___x (HEX)</th> <th>___x (BIN): For manufacturer setting</th> <th rowspan="4">0h</th> </tr> </thead> <tbody> <tr> <td>__x_ (HEX)</td> <td>__x_ (BIN): For manufacturer setting</td> </tr> <tr> <td>_x__ (HEX)</td> <td>_x__ (BIN): For manufacturer setting</td> </tr> <tr> <td>x___ (HEX)</td> <td>x___ (BIN): For manufacturer setting</td> </tr> </tbody> </table> <table border="1"> <thead> <tr> <th>__x_ (HEX)</th> <th>___x (BIN): For manufacturer setting</th> <th rowspan="4">0h</th> </tr> </thead> <tbody> <tr> <td>__x_ (HEX)</td> <td>__x_ (BIN): For manufacturer setting</td> </tr> <tr> <td>_x__ (HEX)</td> <td>_x__ (BIN): For manufacturer setting</td> </tr> <tr> <td>x___ (HEX)</td> <td>x___ (BIN): For manufacturer setting</td> </tr> </tbody> </table> <table border="1"> <thead> <tr> <th>_x__ (HEX)</th> <th>___x (BIN): DI0 (point table No. selection 1)</th> <th rowspan="8">0h</th> </tr> </thead> <tbody> <tr> <td></td> <td>0: Disabled (Use for an external input signal.) 1: Enabled (automatic on)</td> </tr> <tr> <td></td> <td>__x_ (BIN): DI1 (point table No. selection 2) 0: Disabled (Use for an external input signal.) 1: Enabled (automatic on)</td> </tr> <tr> <td></td> <td>_x__ (BIN): DI2 (point table No. selection 3) 0: Disabled (Use for an external input signal.) 1: Enabled (automatic on)</td> </tr> <tr> <td></td> <td>x___ (BIN): DI3 (point table No. selection 4) 0: Disabled (Use for an external input signal.) 1: Enabled (automatic on)</td> </tr> <tr> <td></td> <td>x___ (BIN): DI4 (point table No. selection 5) 0: Disabled (Use for an external input signal.) 1: Enabled (automatic on)</td> </tr> <tr> <td></td> <td>__x_ (BIN): DI5 (point table No. selection 6) 0: Disabled (Use for an external input signal.) 1: Enabled (automatic on)</td> </tr> <tr> <td></td> <td>_x__ (BIN): DI6 (point table No. selection 7) 0: Disabled (Use for an external input signal.) 1: Enabled (automatic on)</td> </tr> <tr> <td></td> <td>x___ (BIN): DI7 (point table No. selection 8) 0: Disabled (Use for an external input signal.) 1: Enabled (automatic on)</td> </tr> </tbody> </table> Convert the setting value into hexadecimal as follows.	___x (HEX)	___x (BIN): For manufacturer setting	0h	__x_ (HEX)	__x_ (BIN): For manufacturer setting	_x__ (HEX)	_x__ (BIN): For manufacturer setting	x___ (HEX)	x___ (BIN): For manufacturer setting	__x_ (HEX)	___x (BIN): For manufacturer setting	0h	__x_ (HEX)	__x_ (BIN): For manufacturer setting	_x__ (HEX)	_x__ (BIN): For manufacturer setting	x___ (HEX)	x___ (BIN): For manufacturer setting	_x__ (HEX)	___x (BIN): DI0 (point table No. selection 1)	0h		0: Disabled (Use for an external input signal.) 1: Enabled (automatic on)		__x_ (BIN): DI1 (point table No. selection 2) 0: Disabled (Use for an external input signal.) 1: Enabled (automatic on)		_x__ (BIN): DI2 (point table No. selection 3) 0: Disabled (Use for an external input signal.) 1: Enabled (automatic on)		x___ (BIN): DI3 (point table No. selection 4) 0: Disabled (Use for an external input signal.) 1: Enabled (automatic on)		x___ (BIN): DI4 (point table No. selection 5) 0: Disabled (Use for an external input signal.) 1: Enabled (automatic on)		__x_ (BIN): DI5 (point table No. selection 6) 0: Disabled (Use for an external input signal.) 1: Enabled (automatic on)		_x__ (BIN): DI6 (point table No. selection 7) 0: Disabled (Use for an external input signal.) 1: Enabled (automatic on)		x___ (BIN): DI7 (point table No. selection 8) 0: Disabled (Use for an external input signal.) 1: Enabled (automatic on)	
Signal name	Initial value																																																																						
	BIN	HEX																																																																					
Point table No.selection 1 (DI0)	0	0																																																																					
Point table No.selection 2 (DI1)	0																																																																						
Point table No.selection 3 (DI2)	0																																																																						
Point table No.selection 4 (DI3)	0																																																																						
Signal name	Initial value																																																																						
	BIN	HEX																																																																					
Point table No.selection 5 (DI4)	0	0																																																																					
Point table No.selection 6 (DI5)	0																																																																						
Point table No.selection 7 (DI6)	0																																																																						
Point table No.selection 8 (DI7)	0																																																																						
___x (HEX)	___x (BIN): For manufacturer setting	0h																																																																					
__x_ (HEX)	__x_ (BIN): For manufacturer setting																																																																						
_x__ (HEX)	_x__ (BIN): For manufacturer setting																																																																						
x___ (HEX)	x___ (BIN): For manufacturer setting																																																																						
__x_ (HEX)	___x (BIN): For manufacturer setting	0h																																																																					
__x_ (HEX)	__x_ (BIN): For manufacturer setting																																																																						
_x__ (HEX)	_x__ (BIN): For manufacturer setting																																																																						
x___ (HEX)	x___ (BIN): For manufacturer setting																																																																						
_x__ (HEX)	___x (BIN): DI0 (point table No. selection 1)	0h																																																																					
	0: Disabled (Use for an external input signal.) 1: Enabled (automatic on)																																																																						
	__x_ (BIN): DI1 (point table No. selection 2) 0: Disabled (Use for an external input signal.) 1: Enabled (automatic on)																																																																						
	_x__ (BIN): DI2 (point table No. selection 3) 0: Disabled (Use for an external input signal.) 1: Enabled (automatic on)																																																																						
	x___ (BIN): DI3 (point table No. selection 4) 0: Disabled (Use for an external input signal.) 1: Enabled (automatic on)																																																																						
	x___ (BIN): DI4 (point table No. selection 5) 0: Disabled (Use for an external input signal.) 1: Enabled (automatic on)																																																																						
	__x_ (BIN): DI5 (point table No. selection 6) 0: Disabled (Use for an external input signal.) 1: Enabled (automatic on)																																																																						
	_x__ (BIN): DI6 (point table No. selection 7) 0: Disabled (Use for an external input signal.) 1: Enabled (automatic on)																																																																						
	x___ (BIN): DI7 (point table No. selection 8) 0: Disabled (Use for an external input signal.) 1: Enabled (automatic on)																																																																						
			<table border="1"> <thead> <tr> <th>Input device</th> <th colspan="2">Initial value</th> </tr> <tr> <th></th> <th>BIN</th> <th>HEX</th> </tr> </thead> <tbody> <tr> <td>DI0 (Point table No. selection 1)</td> <td>0</td> <td rowspan="4">0</td> </tr> <tr> <td>DI1 (Point table No. selection 2)</td> <td>0</td> </tr> <tr> <td>DI2 (Point table No. selection 3)</td> <td>0</td> </tr> <tr> <td>DI3 (Point table No. selection 4)</td> <td>0</td> </tr> </tbody> </table> <table border="1"> <thead> <tr> <th>Input device</th> <th colspan="2">Initial value</th> </tr> <tr> <th></th> <th>BIN</th> <th>HEX</th> </tr> </thead> <tbody> <tr> <td>DI4 (Point table No. selection 5)</td> <td>0</td> <td rowspan="4">0</td> </tr> <tr> <td>DI5 (Point table No. selection 6)</td> <td>0</td> </tr> <tr> <td>DI6 (Point table No. selection 7)</td> <td>0</td> </tr> <tr> <td>DI7 (Point table No. selection 8)</td> <td>0</td> </tr> </tbody> </table> <p>BIN 0: Use for an external input signal. BIN 1: Automatic on</p>	Input device	Initial value			BIN	HEX	DI0 (Point table No. selection 1)	0	0	DI1 (Point table No. selection 2)	0	DI2 (Point table No. selection 3)	0	DI3 (Point table No. selection 4)	0	Input device	Initial value			BIN	HEX	DI4 (Point table No. selection 5)	0	0	DI5 (Point table No. selection 6)	0	DI6 (Point table No. selection 7)	0	DI7 (Point table No. selection 8)	0																																						
Input device	Initial value																																																																						
	BIN	HEX																																																																					
DI0 (Point table No. selection 1)	0	0																																																																					
DI1 (Point table No. selection 2)	0																																																																						
DI2 (Point table No. selection 3)	0																																																																						
DI3 (Point table No. selection 4)	0																																																																						
Input device	Initial value																																																																						
	BIN	HEX																																																																					
DI4 (Point table No. selection 5)	0	0																																																																					
DI5 (Point table No. selection 6)	0																																																																						
DI6 (Point table No. selection 7)	0																																																																						
DI7 (Point table No. selection 8)	0																																																																						

MR-J3-_T_			MR-J4-_A_-RJ																																																																		
No.	Name and function	Initial value	No.	Name and function	Initial value																																																																
PD06	Input signal device selection 2 (CN6-2) Any input device can be assigned to the CN6-2 pin.	002Bh	PD22	Input device selection 10H Any input device can be assigned to the CN1-45 pin.																																																																	
	0 0 x x: Select the input device of the CN6-2 pin 0 0: No assignment function 0 2: Servo-on (SON) 0 3: Reset (RES) 0 4: Proportion control (PC) 0 5: External torque limit selection (TL) 0 6: Clear (CR) 0 7: Forward rotation start (ST1) 0 8: Reverse rotation start (ST2) 0 9: Internal torque limit selection (TL2) 0 A: Forward rotation stroke end (LSP) 0 B: Reverse rotation stroke end (LSN) 0 D: Gain switch (CDP) 2 0: Automatic/manual selection (MD0) 2 4: Manual pulse generator multiplication 1 (TP0) 2 5: Manual pulse generator multiplication 2 (TP1) 2 6: Override selection (OVR) 2 7: Temporary stop/restart (TSTP) 2 B: Proximity dog (DOG) 2 F: Speed selection 4 (SP3) Note. The other setting values than shown in this table are for manufacturer setting.			__ x x: Not used with the positioning mode.		23h																																																															
				x x __: Positioning mode - Device selection Refer to table 6.10 for settings.	2Bh																																																																
				Table 6.10 Selectable input devices																																																																	
				<table border="1"> <thead> <tr> <th>Setting value</th> <th>Input device (Note 1) CP/BCD</th> <th>Setting value</th> <th>Input device (Note 1) CP/BCD</th> </tr> </thead> <tbody> <tr><td>0 2 __</td><td>SON</td><td>2 6 __</td><td>OVR</td></tr> <tr><td>0 3 __</td><td>RES</td><td>2 7 __</td><td>TSTP</td></tr> <tr><td>0 4 __</td><td>PC</td><td>2 B __</td><td>DOG</td></tr> <tr><td>0 5 __</td><td>TL</td><td>2 C __</td><td>SPD1 (Note 2)</td></tr> <tr><td>0 6 __</td><td>CR</td><td>2 D __</td><td>SPD2 (Note 2)</td></tr> <tr><td>0 7 __</td><td>ST1</td><td>2 E __</td><td>SPD3 (Note 2)</td></tr> <tr><td>0 8 __</td><td>ST2</td><td>2 F __</td><td>SPD4 (Note 2)</td></tr> <tr><td>0 9 __</td><td>TL1</td><td>3 8 __</td><td>DI0</td></tr> <tr><td>0 A __</td><td>LSP</td><td>3 9 __</td><td>DI1</td></tr> <tr><td>0 B __</td><td>LSN</td><td>3 A __</td><td>DI2</td></tr> <tr><td>0 D __</td><td>CDP</td><td>3 B __</td><td>DI3</td></tr> <tr><td>2 0 __</td><td>MD0</td><td>3 C __</td><td>DI4</td></tr> <tr><td>2 3 __</td><td>TCH</td><td>3 D __</td><td>DI5</td></tr> <tr><td>2 4 __</td><td>TP0</td><td>3 E __</td><td>DI6</td></tr> <tr><td>2 5 __</td><td>TP1</td><td>3 F __</td><td>DI7</td></tr> </tbody> </table>	Setting value	Input device (Note 1) CP/BCD	Setting value	Input device (Note 1) CP/BCD	0 2 __	SON	2 6 __	OVR	0 3 __	RES	2 7 __	TSTP	0 4 __	PC	2 B __	DOG	0 5 __	TL	2 C __	SPD1 (Note 2)	0 6 __	CR	2 D __	SPD2 (Note 2)	0 7 __	ST1	2 E __	SPD3 (Note 2)	0 8 __	ST2	2 F __	SPD4 (Note 2)	0 9 __	TL1	3 8 __	DI0	0 A __	LSP	3 9 __	DI1	0 B __	LSN	3 A __	DI2	0 D __	CDP	3 B __	DI3	2 0 __	MD0	3 C __	DI4	2 3 __	TCH	3 D __	DI5	2 4 __	TP0	3 E __	DI6	2 5 __	TP1	3 F __	DI7	
Setting value	Input device (Note 1) CP/BCD	Setting value	Input device (Note 1) CP/BCD																																																																		
0 2 __	SON	2 6 __	OVR																																																																		
0 3 __	RES	2 7 __	TSTP																																																																		
0 4 __	PC	2 B __	DOG																																																																		
0 5 __	TL	2 C __	SPD1 (Note 2)																																																																		
0 6 __	CR	2 D __	SPD2 (Note 2)																																																																		
0 7 __	ST1	2 E __	SPD3 (Note 2)																																																																		
0 8 __	ST2	2 F __	SPD4 (Note 2)																																																																		
0 9 __	TL1	3 8 __	DI0																																																																		
0 A __	LSP	3 9 __	DI1																																																																		
0 B __	LSN	3 A __	DI2																																																																		
0 D __	CDP	3 B __	DI3																																																																		
2 0 __	MD0	3 C __	DI4																																																																		
2 3 __	TCH	3 D __	DI5																																																																		
2 4 __	TP0	3 E __	DI6																																																																		
2 5 __	TP1	3 F __	DI7																																																																		
				Note 1. CP: Positioning mode (point table method) BCD: Positioning mode (point table method in the BCD input positioning operation) This method is available only when the MR-D01 unit is connected. Refer to chapter 12 for details. The diagonal lines indicate manufacturer settings. Never change the setting. 2. This is available with servo amplifiers with software version B7 or later.																																																																	
PD07	Input signal device selection 3 (CN6-3) Any input device can be assigned to the CN6-3 pin. The devices that can be assigned and the setting method are the same as in [Pr. PD06].	000Ah	PD18	Input device selection 8H Any input device can be assigned to the CN1-43 pin.																																																																	
	0 0 x x: Select the input device of the CN6-3 pin			__ x x: Not used with the positioning mode.		00h																																																															
				x x __: Positioning mode - Device selection Refer to table 6.10 in [Pr. PD22] for settings.	0Ah																																																																
PD08	Input signal device selection 4 (CN6-4) Any input device can be assigned to the CN6-4 pin. The devices that can be assigned and the setting method are the same as in [Pr. PD06].	000Bh	PD20	Input device selection 9H Any input device can be assigned to the CN1-44 pin.																																																																	
	0 0 x x: Select the input device of the CN6-4 pin			__ x x: Not used with the positioning mode.		00h																																																															
				x x __: Positioning mode - Device selection Refer to table 6.10 in [Pr. PD22] for settings.	0Bh																																																																

MR-J3-_T_			MR-J4-_A_-RJ																																																																				
No.	Name and function	Initial value	No.	Name and function	Initial value																																																																		
PD09	Output signal device selection 1 (CN6-14) Any output signal can be assigned to the CN6-14 pin.	0002h	PD28	Output device selection 6	02h																																																																		
	0 0 x x: Select the output device of the CN6-14 pin 0 0: Always OFF 0 2: Ready (RD) 0 3: Trouble (ALM) 0 4: In position (INP) 0 5: Electromagnetic brake interlock (MBR) 0 6: Dynamic brake interlock (DB) 0 7: Limiting torque (TLC) 0 8: Warning (WNG) 0 9: Battery warning (BWNG) 0 A: Speed command reached (SA) 0 C: Zero speed (ZSP) 0 F: Variable gain selection (CDPS) 2 3: Rough match (CPO) 2 4: Home position return completion (ZP) 2 5: Position range (POT) 2 6: Temporary stop (PUS) 2 7: Movement finish (MEND) 3 8: Point table No. output 1 (PT0) 3 9: Point table No. output 2 (PT1) 3 A: Point table No. output 3 (PT2) 3 B: Point table No. output 4 (PT3) 3 C: Point table No. output 5 (PT4) 3 D: Point table No. output 6 (PT5) 3 E: Point table No. output 7 (PT6) 3 F: Point table No. output 8 (PT7) Note. The other setting values than shown in this table are for manufacturer setting.			__ x x: Device selection Any output device can be assigned to the CN1-49 pin. Refer to table 6.11 for settings.																																																																			
				_ x _ : For manufacturer setting	0h																																																																		
				x _ _ : For manufacturer setting	0h																																																																		
<p>Table 6.11 Selectable output devices</p> <table border="1" style="width: 100%; border-collapse: collapse;"> <thead> <tr> <th rowspan="2">Setting value</th> <th>Output device (Note)</th> <th rowspan="2">Setting value</th> <th>Output device (Note)</th> </tr> <tr> <th>CP/BCD</th> <th>CP/BCD</th> </tr> </thead> <tbody> <tr><td>__ 0 0</td><td>Always off</td><td>__ 2 4</td><td>ZP</td></tr> <tr><td>__ 0 2</td><td>RD</td><td>__ 2 5</td><td>POT</td></tr> <tr><td>__ 0 3</td><td>ALM</td><td>__ 2 6</td><td>PUS</td></tr> <tr><td>__ 0 4</td><td>INP</td><td>__ 2 7</td><td>MEND</td></tr> <tr><td>__ 0 5</td><td>MBR</td><td>__ 2 C</td><td>PED</td></tr> <tr><td>__ 0 6</td><td>DB</td><td>__ 3 1</td><td>ALMWNG</td></tr> <tr><td>__ 0 7</td><td>TLC</td><td>__ 3 2</td><td>BW9F</td></tr> <tr><td>__ 0 8</td><td>WNG</td><td>__ 3 8</td><td>PT0</td></tr> <tr><td>__ 0 9</td><td>BWNG</td><td>__ 3 9</td><td>PT1</td></tr> <tr><td>__ 0 A</td><td>SA</td><td>__ 3 A</td><td>PT2</td></tr> <tr><td>__ 0 B</td><td>Always off</td><td>__ 3 B</td><td>PT3</td></tr> <tr><td>__ 0 C</td><td>ZSP</td><td>__ 3 C</td><td>PT4</td></tr> <tr><td>__ 0 F</td><td>CDPS</td><td>__ 3 D</td><td>PT5</td></tr> <tr><td>__ 1 1</td><td>ABSV</td><td>__ 3 E</td><td>PT6</td></tr> <tr><td>__ 2 3</td><td>CPO</td><td>__ 3 F</td><td>PT7</td></tr> </tbody> </table> <p>Note . CP: Positioning mode (point table method) The diagonal lines indicate manufacturer settings. Never change the setting.</p>						Setting value	Output device (Note)	Setting value	Output device (Note)	CP/BCD	CP/BCD	__ 0 0	Always off	__ 2 4	ZP	__ 0 2	RD	__ 2 5	POT	__ 0 3	ALM	__ 2 6	PUS	__ 0 4	INP	__ 2 7	MEND	__ 0 5	MBR	__ 2 C	PED	__ 0 6	DB	__ 3 1	ALMWNG	__ 0 7	TLC	__ 3 2	BW9F	__ 0 8	WNG	__ 3 8	PT0	__ 0 9	BWNG	__ 3 9	PT1	__ 0 A	SA	__ 3 A	PT2	__ 0 B	Always off	__ 3 B	PT3	__ 0 C	ZSP	__ 3 C	PT4	__ 0 F	CDPS	__ 3 D	PT5	__ 1 1	ABSV	__ 3 E	PT6	__ 2 3	CPO	__ 3 F	PT7
Setting value	Output device (Note)	Setting value	Output device (Note)																																																																				
	CP/BCD		CP/BCD																																																																				
__ 0 0	Always off	__ 2 4	ZP																																																																				
__ 0 2	RD	__ 2 5	POT																																																																				
__ 0 3	ALM	__ 2 6	PUS																																																																				
__ 0 4	INP	__ 2 7	MEND																																																																				
__ 0 5	MBR	__ 2 C	PED																																																																				
__ 0 6	DB	__ 3 1	ALMWNG																																																																				
__ 0 7	TLC	__ 3 2	BW9F																																																																				
__ 0 8	WNG	__ 3 8	PT0																																																																				
__ 0 9	BWNG	__ 3 9	PT1																																																																				
__ 0 A	SA	__ 3 A	PT2																																																																				
__ 0 B	Always off	__ 3 B	PT3																																																																				
__ 0 C	ZSP	__ 3 C	PT4																																																																				
__ 0 F	CDPS	__ 3 D	PT5																																																																				
__ 1 1	ABSV	__ 3 E	PT6																																																																				
__ 2 3	CPO	__ 3 F	PT7																																																																				
PD10	Output signal device selection 2 (CN6-15) Any output signal can be assigned to the CN6-15 pin. The devices that can be assigned and the setting method are the same as in [Pr. PD09].	0003h	PD27	For manufacturer setting																																																																			
	0 0 x x: Select the output device of the CN6-15 pin																																																																						
PD11	Output signal device selection 3 (CN6-16) Any output signal can be assigned to the CN6-16 pin. The devices that can be assigned and the setting method are the same as in [Pr. PD09].	0024h	PD24	Output device selection 2	0Ch																																																																		
	0 0 x x: Select the output device of the CN6-16 pin			__ x x: Device selection Any output device can be assigned to the CN1-23 pin. Refer to table 6.11 in [Pr. PD28] for settings.																																																																			
				_ x _ : For manufacturer setting	0h																																																																		
				x _ _ : For manufacturer setting	0h																																																																		

MR-J3-_T_			MR-J4-_A_-RJ																																		
No.	Name and function	Initial value	No.	Name and function	Initial value																																
PD16	Input polarity selection Used to set the proximity dog input polarity.	0000h	PT29	Function selection T-3 Set a polarity of DOG.	0h																																
	0 0 0 x: Proximity dog input polarity 0: OFF indicates detection of the dog. 1: ON indicates detection of the dog.			<table border="1"> <tr> <td>___x (HEX)</td> <td>___x (BIN): DOG (Proximity dog) polarity selection</td> <td rowspan="5">0h</td> </tr> <tr> <td></td> <td>0: Dog detection with off</td> </tr> <tr> <td></td> <td>1: Dog detection with on</td> </tr> <tr> <td></td> <td>___x (BIN): For manufacturer setting</td> </tr> <tr> <td></td> <td>__x_ (BIN): For manufacturer setting</td> </tr> <tr> <td></td> <td>_x__ (BIN): For manufacturer setting</td> <td rowspan="4">0h</td> </tr> <tr> <td>__x_ (HEX)</td> <td>___x (BIN): For manufacturer setting</td> </tr> <tr> <td></td> <td>__x_ (BIN): For manufacturer setting</td> </tr> <tr> <td></td> <td>_x__ (BIN): For manufacturer setting</td> </tr> <tr> <td></td> <td>x___ (BIN): For manufacturer setting</td> <td>0h</td> </tr> <tr> <td></td> <td>_x__</td> <td>For manufacturer setting</td> <td>0h</td> </tr> <tr> <td></td> <td>x___</td> <td>For manufacturer setting</td> <td>0h</td> </tr> </table>		___x (HEX)	___x (BIN): DOG (Proximity dog) polarity selection	0h		0: Dog detection with off		1: Dog detection with on		___x (BIN): For manufacturer setting		__x_ (BIN): For manufacturer setting		_x__ (BIN): For manufacturer setting	0h	__x_ (HEX)	___x (BIN): For manufacturer setting		__x_ (BIN): For manufacturer setting		_x__ (BIN): For manufacturer setting		x___ (BIN): For manufacturer setting	0h		_x__	For manufacturer setting	0h		x___	For manufacturer setting	0h	
___x (HEX)	___x (BIN): DOG (Proximity dog) polarity selection	0h																																			
	0: Dog detection with off																																				
	1: Dog detection with on																																				
	___x (BIN): For manufacturer setting																																				
	__x_ (BIN): For manufacturer setting																																				
	_x__ (BIN): For manufacturer setting	0h																																			
__x_ (HEX)	___x (BIN): For manufacturer setting																																				
	__x_ (BIN): For manufacturer setting																																				
	_x__ (BIN): For manufacturer setting																																				
	x___ (BIN): For manufacturer setting	0h																																			
	_x__	For manufacturer setting	0h																																		
	x___	For manufacturer setting	0h																																		
				Convert the setting value into hexadecimal as follows. <table border="1"> <thead> <tr> <th rowspan="2">Setting</th> <th colspan="2">Initial value</th> </tr> <tr> <th>BIN</th> <th>HEX</th> </tr> </thead> <tbody> <tr> <td>DOG (Proximity dog) polarity selection</td> <td>0</td> <td rowspan="4">0</td> </tr> <tr> <td></td> <td>0</td> </tr> <tr> <td></td> <td>0</td> </tr> <tr> <td></td> <td>0</td> </tr> </tbody> </table>	Setting	Initial value		BIN	HEX	DOG (Proximity dog) polarity selection	0	0		0		0		0																			
Setting	Initial value																																				
	BIN	HEX																																			
DOG (Proximity dog) polarity selection	0	0																																			
	0																																				
	0																																				
	0																																				
PD19	Response level setting Used to select the input.	0002h	PD29	Input filter setting Select a filter for the input signal.	4h																																
	0 0 0 x: Input filter If external input signal causes chattering due to noise, etc., input filter is used to suppress it. 0: None 1: 0.888 [ms] 2: 1.777 [ms] 3: 2.660 [ms] 4: 3.555 [ms] 5: 4.444 [ms]			<table border="1"> <tr> <td>___x:</td> <td>Input signal filter selection</td> <td rowspan="7">0h</td> </tr> <tr> <td></td> <td>If external input signal causes chattering due to noise, etc., input filter is used to suppress it.</td> </tr> <tr> <td></td> <td>0: None</td> </tr> <tr> <td></td> <td>1: 0.888 [ms]</td> </tr> <tr> <td></td> <td>2: 1.777 [ms]</td> </tr> <tr> <td></td> <td>3: 2.666 [ms]</td> </tr> <tr> <td></td> <td>4: 3.555 [ms]</td> </tr> <tr> <td></td> <td>5: 4.444 [ms]</td> </tr> <tr> <td></td> <td>6: 5.333 [ms]</td> <td rowspan="3">0h</td> </tr> <tr> <td>__x_:</td> <td>RES (Reset) dedicated filter selection</td> </tr> <tr> <td></td> <td>0: Disabled</td> </tr> <tr> <td></td> <td>1: Enabled (50 [ms])</td> <td rowspan="2">0h</td> </tr> <tr> <td>_x__:</td> <td>CR (Clear) dedicated filter selection</td> </tr> <tr> <td></td> <td>0: Disabled</td> </tr> <tr> <td></td> <td>1: Enabled (50 [ms])</td> <td rowspan="2">0h</td> </tr> <tr> <td>x___:</td> <td>For manufacturer setting</td> </tr> </table>		___x:	Input signal filter selection	0h		If external input signal causes chattering due to noise, etc., input filter is used to suppress it.		0: None		1: 0.888 [ms]		2: 1.777 [ms]		3: 2.666 [ms]		4: 3.555 [ms]		5: 4.444 [ms]		6: 5.333 [ms]	0h	__x_:	RES (Reset) dedicated filter selection		0: Disabled		1: Enabled (50 [ms])	0h	_x__:	CR (Clear) dedicated filter selection		0: Disabled	
___x:	Input signal filter selection	0h																																			
	If external input signal causes chattering due to noise, etc., input filter is used to suppress it.																																				
	0: None																																				
	1: 0.888 [ms]																																				
	2: 1.777 [ms]																																				
	3: 2.666 [ms]																																				
	4: 3.555 [ms]																																				
	5: 4.444 [ms]																																				
	6: 5.333 [ms]	0h																																			
__x_:	RES (Reset) dedicated filter selection																																				
	0: Disabled																																				
	1: Enabled (50 [ms])	0h																																			
_x__:	CR (Clear) dedicated filter selection																																				
	0: Disabled																																				
	1: Enabled (50 [ms])	0h																																			
x___:	For manufacturer setting																																				

MR-J3-_T_			MR-J4-_A_-RJ		
No.	Name and function	Initial value	No.	Name and function	Initial value
PD20	<p>Function selection D-1</p> <p>Select the stop processing at forward rotation stroke end (LSN)/reverse rotation stroke end (LSN) OFF and the base circuit status at reset (RES) ON.</p> <p>0 __ x:</p> <p>Stopping method used when forward rotation stroke end (LSP), reverse rotation stroke end (LSN) device or software limit is valid</p> <p>0: Sudden stop (home position erased)</p> <p>1: Slow stop (home position erased)</p> <p>2: Slow stop (Deceleration to a stop by deceleration time constant)</p> <p>3: Sudden stop (Stop by remaining move distance clear)</p> <p>0 x _:</p> <p>Selection of base circuit status at reset (RES)ON</p> <p>0: Base circuit not switched off</p> <p>1: Base circuit switched off</p> <p>0 x _ _:</p> <p>Stopping method used when software limit is valid</p> <p>0: Sudden stop (home position erased)</p> <p>1: Slow stop (home position erased)</p> <p>2: Slow stop (Deceleration to a stop by deceleration time constant)</p> <p>3: Sudden stop (Stop by remaining move distance clear)</p> <p>As in the following parameter settings, when the home position is lost by the forward rotation stroke end, reverse rotation stroke end, or the software limit detection, the home position return completion (ZP) turns on by turning OFF/ON the servo-on (SON). In this case, there is no need to perform the home position return again.</p> <p>1. In absolute position detection system</p> <p>[Pr. PA03]: ___ 1 (Select the absolute position detection system)</p> <p>[Pr. PA01]: ___ 0 (Select the absolute value command system)</p> <p>2. In incremental system</p> <p>[Pr. PA03]: ___ 0 (Select the incremental system)</p> <p>[Pr. PA01]: ___ 0 (Select the absolute value command system)</p> <p>[Pr. PA04]: ___ 1 (Follow-up valid)</p>	0010h	PD30	<p>Function selection D-1</p> <p>___ x:</p> <p>Stop method selection for LSP (Forward rotation stroke end) off or LSN (Reverse rotation stroke end) off</p> <p>Select a stop method for LSP (Forward rotation stroke end) off or LSN (Reverse rotation stroke end) off.</p> <p>0: Quick stop (home position erased)</p> <p>1: Slow stop (home position erased)</p> <p>2: Slow stop (deceleration to a stop by deceleration time constant)</p> <p>3: Quick stop (stop by clearing remaining distance)</p> <p>___ x _:</p> <p>Base circuit status selection for RES (Reset) on</p> <p>0: Base circuit shut-off</p> <p>1: No base circuit shut-off</p> <p>_ x _ _:</p> <p>Stop method selection at software limit detection</p> <p>Select a stop method selection at software limit detection. (Refer to section 7.6.)</p> <p>0: Quick stop (home position erased)</p> <p>1: Slow stop (home position erased)</p> <p>2: Slow stop (deceleration to a stop by deceleration time constant)</p> <p>3: Quick stop (stop by clearing remaining distance)</p> <p>x ___:</p> <p>Enabled/disabled selection for a thermistor of servo motor</p> <p>0: Enabled</p> <p>1: Disabled</p> <p>The setting in this digit will be disabled when using a servo motor without thermistor.</p>	0h

MR-J3-_T_			MR-J4-_A_-RJ																						
No.	Name and function	Initial value	No.	Name and function	Initial value																				
PD22	Function selection D-3 Set the clear (CR).	0000h	PD32	Function selection D-3	0h																				
	0 0 0 x: Clear (CR) selection 0: Disabled 1: Droop pulses are cleared on the leading edge. 2: While on, droop pulses are always cleared.			___x CR (Clear) selection This is used to set CR (Clear). 0: Deleting droop pulses by turning on the device 1: Continuous deleting of droop pulses during the device on 2: Disabled																					
PT26			PT26	Function selection T-2	0h																				
				___x: Electronic gear fraction clear selection 0: Disabled 1: Enabled Selecting "Enabled" will clear a fraction of the previous command by the electronic gear at start of the automatic operation. Setting "2" or more to this digit will be "Disabled".																					
				___x : Current position/command position display selection Select how to display a current position and command position.	0h																				
				<table border="1"> <thead> <tr> <th rowspan="2">Setting value</th> <th rowspan="2">Displayed data</th> <th rowspan="2">Operation mode</th> <th colspan="2">Status display</th> </tr> <tr> <th>Current position</th> <th>Command position</th> </tr> </thead> <tbody> <tr> <td>__ 0 _</td> <td>Positioning display</td> <td>Auto/Manual</td> <td>Actual current position will be displayed as machine home position is 0.</td> <td>Command current position will be displayed as machine home position is 0.</td> </tr> <tr> <td>__ 1 _</td> <td rowspan="2">Roll feed display</td> <td>Auto</td> <td rowspan="2">Actual current position will be displayed as automatic operation start position is 0.</td> <td>When ST1 (Forward rotation start) or ST2 (Reverse rotation start) is turned on, counting starts from 0 and a command current position to the target position will be displayed. When a stop, a point table command position for the point table method will be displayed and 0 will be continuously displayed.</td> </tr> <tr> <td></td> <td>Manual</td> <td>0 will be continuously displayed.</td> </tr> </tbody> </table>	Setting value	Displayed data	Operation mode	Status display		Current position	Command position	__ 0 _	Positioning display	Auto/Manual	Actual current position will be displayed as machine home position is 0.	Command current position will be displayed as machine home position is 0.	__ 1 _	Roll feed display	Auto	Actual current position will be displayed as automatic operation start position is 0.	When ST1 (Forward rotation start) or ST2 (Reverse rotation start) is turned on, counting starts from 0 and a command current position to the target position will be displayed. When a stop, a point table command position for the point table method will be displayed and 0 will be continuously displayed.		Manual	0 will be continuously displayed.	
Setting value	Displayed data	Operation mode	Status display																						
			Current position	Command position																					
__ 0 _	Positioning display	Auto/Manual	Actual current position will be displayed as machine home position is 0.	Command current position will be displayed as machine home position is 0.																					
__ 1 _	Roll feed display	Auto	Actual current position will be displayed as automatic operation start position is 0.	When ST1 (Forward rotation start) or ST2 (Reverse rotation start) is turned on, counting starts from 0 and a command current position to the target position will be displayed. When a stop, a point table command position for the point table method will be displayed and 0 will be continuously displayed.																					
		Manual		0 will be continuously displayed.																					
				___x : For manufacturer setting	0h																				
				x ___ : For manufacturer setting	0h																				

MR-J3-_T_			MR-J4-_A_-RJ																			
No.	Name and function	Initial value	No.	Name and function	Initial value																	
PD24	Function selection D-5 Select the output status of the warning (WNG).	0002h	PD34	Function selection D-5	0h																	
	<p>0 0 x 0: Selection of output device at warning occurrence Select the warning (WNG) and trouble (ALM) output status at warning occurrence.</p> <table border="1"> <thead> <tr> <th>Setting</th> <th colspan="2">Device status</th> </tr> </thead> <tbody> <tr> <td rowspan="2">0</td> <td>WNG</td> <td>ON OFF</td> <td></td> </tr> <tr> <td>ALM</td> <td>ON OFF</td> <td></td> </tr> <tr> <td rowspan="2">1</td> <td>WNG</td> <td>ON OFF</td> <td></td> </tr> <tr> <td>ALM</td> <td>ON OFF</td> <td></td> </tr> </tbody> </table> <p>Note. 0: OFF 1: ON</p>			Setting		Device status		0	WNG	ON OFF		ALM	ON OFF		1	WNG	ON OFF		ALM	ON OFF		<p>___x Alarm code output Select an output alarm codes. When an alarm occurs, the alarm code is outputted to CN1-22, CN1-23, and CN1-24 pins. 0: Disabled 1: Enabled For details of the alarm codes, refer to "MR-J4-_A_-RJ/MR-J4-03A-RJ Servo Amplifier Instruction Manual (Positioning mode)" chapter 8. When "1" is set for this digit, setting the following will trigger [AL. 37 Parameter error].</p> <ul style="list-style-type: none"> "___1" is set in [Pr. PA03] and the absolute position detection system by DIO is selected. MBR, DB, or ALM is assigned to the CN1-22 pin, CN1-23 pin, or CN1-24 pin.
Setting	Device status																					
0	WNG	ON OFF																				
	ALM	ON OFF																				
1	WNG	ON OFF																				
	ALM	ON OFF																				
				<p>__x_: Selection of output device at warning occurrence Select ALM (Malfunction) output status for when an warning occurs.</p> <table border="1"> <thead> <tr> <th>Setting value</th> <th colspan="2">Device status</th> </tr> </thead> <tbody> <tr> <td rowspan="2">0</td> <td>WNG</td> <td>ON OFF</td> <td></td> </tr> <tr> <td>ALM</td> <td>ON OFF</td> <td></td> </tr> <tr> <td rowspan="2">1</td> <td>WNG</td> <td>ON OFF</td> <td></td> </tr> <tr> <td>ALM</td> <td>ON OFF</td> <td></td> </tr> </tbody> </table>	Setting value	Device status		0	WNG	ON OFF		ALM	ON OFF		1	WNG	ON OFF		ALM	ON OFF		0h
Setting value	Device status																					
0	WNG	ON OFF																				
	ALM	ON OFF																				
1	WNG	ON OFF																				
	ALM	ON OFF																				
				x: For manufacturer setting	0h																	
				x_: For manufacturer setting	0h																	

MR-J3-_T_			MR-J4-_A_-RJ																																																																								
No.	Name and function	Initial value	No.	Name and function	Initial value																																																																						
Po02	MR-J3-D01 input signal device selection 2 (CN10-21, 26) Any input signal can be assigned to the CN10-21, 26 pin.	0302h	Po02	MR-D01 input device selection 1 Any input device can be assigned to the CN10-21 pin and CN10-26 pin.	02h																																																																						
	__ x x: Select the input device of the CN10-21 pin x x __: Select the input device of the CN10-26 pin The devices that can be assigned are indicated in the following table. 0 0: No assignment function 0 2: Servo-on (SON) 0 3: Reset (RES) 0 4: Proportion control (PC) 0 5: External torque limit selection (TL) 0 6: Clear (CR) 0 7: Forward rotation start (ST1) 0 8: Reverse rotation start (ST2) 0 9: Internal torque limit selection (TL1) 0 A: Forward rotation stroke end (LSP) 0 B: Reverse rotation stroke end (LSN) 0 D: Gain changing (CDP) 2 0: Automatic/manual selection (MD0) 2 4: Manual pulse generator multiplication 1 (TP0) 2 5: Manual pulse generator multiplication 2 (TP1) 2 6: Override selection (OVR) 2 7: Temporary stop/restart (TSTP) 2 B: Proximity dog (DOG) 2 F: Speed selection 4 (SP3) Note. The other setting values than shown in this table are for manufacturer setting.			__ x x: CN10-21 selection Select an input signal function of the CN10-21 pin. Refer to table 6.14 for settings. This parameter setting is available with servo amplifiers with software version B7 or later. x x __: CN10-26 selection Select an input signal function of the CN10-26 pin. Refer to table 6.14 for settings. This parameter setting is available with servo amplifiers with software version B7 or later.		03h																																																																					
			Table 6.14 Selectable input devices																																																																								
			<table border="1"> <thead> <tr> <th rowspan="2">Setting value</th> <th>Input device (Note)</th> <th rowspan="2">Setting value</th> <th>Input device (Note)</th> </tr> <tr> <th>CP/BCD</th> <th>CP/BCD</th> </tr> </thead> <tbody> <tr><td>02</td><td>SON</td><td>27</td><td>TSTP</td></tr> <tr><td>03</td><td>RES</td><td>2B</td><td>DOG</td></tr> <tr><td>04</td><td>PC</td><td>2C</td><td>SPD1</td></tr> <tr><td>05</td><td>TL</td><td>2D</td><td>SPD2</td></tr> <tr><td>06</td><td>CR</td><td>2E</td><td>SPD3</td></tr> <tr><td>07</td><td>ST1</td><td>2F</td><td>SPD4</td></tr> <tr><td>08</td><td>ST2</td><td>2F</td><td>SPD4</td></tr> <tr><td>09</td><td>TL1</td><td>38</td><td>DI0</td></tr> <tr><td>0A</td><td>LSP</td><td>39</td><td>DI1</td></tr> <tr><td>0B</td><td>LSN</td><td>3A</td><td>DI2</td></tr> <tr><td>0D</td><td>CDP</td><td>3B</td><td>DI3</td></tr> <tr><td>20</td><td>MD0</td><td>3C</td><td>DI4</td></tr> <tr><td>23</td><td>TCH</td><td>3D</td><td>DI5</td></tr> <tr><td>24</td><td>TP0</td><td>3E</td><td>DI6</td></tr> <tr><td>25</td><td>TP1</td><td>3F</td><td>DI7</td></tr> <tr><td>26</td><td>OVR</td><td></td><td></td></tr> </tbody> </table>			Setting value	Input device (Note)	Setting value	Input device (Note)	CP/BCD	CP/BCD	02	SON	27	TSTP	03	RES	2B	DOG	04	PC	2C	SPD1	05	TL	2D	SPD2	06	CR	2E	SPD3	07	ST1	2F	SPD4	08	ST2	2F	SPD4	09	TL1	38	DI0	0A	LSP	39	DI1	0B	LSN	3A	DI2	0D	CDP	3B	DI3	20	MD0	3C	DI4	23	TCH	3D	DI5	24	TP0	3E	DI6	25	TP1	3F	DI7	26	OVR		
Setting value	Input device (Note)	Setting value	Input device (Note)																																																																								
	CP/BCD		CP/BCD																																																																								
02	SON	27	TSTP																																																																								
03	RES	2B	DOG																																																																								
04	PC	2C	SPD1																																																																								
05	TL	2D	SPD2																																																																								
06	CR	2E	SPD3																																																																								
07	ST1	2F	SPD4																																																																								
08	ST2	2F	SPD4																																																																								
09	TL1	38	DI0																																																																								
0A	LSP	39	DI1																																																																								
0B	LSN	3A	DI2																																																																								
0D	CDP	3B	DI3																																																																								
20	MD0	3C	DI4																																																																								
23	TCH	3D	DI5																																																																								
24	TP0	3E	DI6																																																																								
25	TP1	3F	DI7																																																																								
26	OVR																																																																										
			Note. CP: Positioning mode (point table method) BCD: Positioning mode (point table method in the BCD input positioning operation) The diagonal lines indicate manufacturer settings. Never change the setting.																																																																								
Po03	MR-J3-D01 input signal device selection 2 (CN10-27, 28) Any input signal can be assigned to the CN10-27, 28 pin. The devices that can be assigned and the setting method are the same as in [Pr. Po02].	0905h	Po03	MR-D01 input device selection 2 Any input device can be assigned to the CN10-27 pin and CN10-28 pin.	05h																																																																						
	__ x x: Select the input device of the CN10-27 pin x x __: Select the input device of the CN10-28 pin			__ x x: CN10-27 selection Select an input signal function of the CN10-27 pin. Refer to table 6.14 in [Pr. Po02] for setting values. This parameter setting is available with servo amplifiers with software version B7 or later. x x __: CN10-28 selection Select an input signal function of the CN10-28 pin. Refer to table 6.14 in [Pr. Po02] for setting values. This parameter setting is available with servo amplifiers with software version B7 or later.		09h																																																																					

MR-J3-_T_			MR-J4-_A_-RJ		
No.	Name and function	Initial value	No.	Name and function	Initial value
Po04	MR-J3-D01 input signal device selection 3 (CN10-29, 30) Any input signal can be assigned to the CN10-29, 30 pin. The devices that can be assigned and the setting method are the same as in [Pr. Po02].	2524h	Po04	MR-D01 input device selection 3 Any input device can be assigned to the CN10-29 pin and CN10-30 pin.	24h
	__ x x: Select the input device of the CN10-29 pin			__ x x: CN10-28 selection Select an input signal function of the CN10-28 pin. Refer to table 6.14 in [Pr. Po02] for setting values. This parameter setting is available with servo amplifiers with software version B7 or later.	
	x x __: Select the input device of the CN10-30 pin			x x __: CN10-30 selection Select an input signal function of the CN10-30 pin. Refer to table 6.14 in [Pr. Po02] for setting values. This parameter setting is available with servo amplifiers with software version B7 or later.	
Po05	MR-J3-D01 input signal device selection 4 (CN10-31, 32) Any input signal can be assigned to the CN10-31, 32 pin. The devices that can be assigned and the setting method are the same as in [Pr. Po02].	2026h	Po05	MR-D01 input device selection 4 Any input device can be assigned to the CN10-31 pin and CN10-32 pin.	26h
	__ x x: Select the input device of the CN10-31 pin			__ x x: CN10-31 selection Select an input signal function of the CN10-31 pin. Refer to table 6.14 in [Pr. Po02] for setting values. This parameter setting is available with servo amplifiers with software version B7 or later.	
	x x __: Select the input device of the CN10-32 pin			x x __: CN10-32 selection Select an input signal function of the CN10-32 pin. Refer to table 6.14 in [Pr. Po02] for setting values. This parameter setting is available with servo amplifiers with software version B7 or later.	
Po06	MR-J3-D01 input signal device selection 5 (CN10-33, 34) Any input signal can be assigned to the CN10-33, 34 pin. The devices that can be assigned and the setting method are the same as in [Pr. Po02].	0427h	Po06	MR-D01 input device selection 5 Any input device can be assigned to the CN10-33 pin and CN10-34 pin.	27h
	__ x x: Select the input device of the CN10-33 pin			__ x x: CN10-33 selection Select an input signal function of the CN10-33 pin. Refer to table 6.14 in [Pr. Po02] for setting values. This parameter setting is available with servo amplifiers with software version B7 or later.	
	x x __: Select the input device of the CN10-34 pin			x x __: CN10-34 selection Select an input signal function of the CN10-34 pin. Refer to table 6.14 in [Pr. Po02] for setting values. This parameter setting is available with servo amplifiers with software version B7 or later.	
Po07	MR-J3-D01 input signal device selection 6 (CN10-35, 36) Any input signal can be assigned to the CN10-35, 36 pin. The devices that can be assigned and the setting method are the same as in [Pr. Po02].	0807h	Po07	MR-D01 input device selection 6 Any input device can be assigned to the CN10-35 pin and CN10-36 pin.	07h
	__ x x: Select the input device of the CN10-35 pin			__ x x: CN10-35 selection Select an input signal function of the CN10-35 pin. Refer to table 6.14 in [Pr. Po02] for setting values. This parameter setting is available with servo amplifiers with software version B7 or later.	
	x x __: Select the input device of the CN10-36 pin			x x __: CN10-36 selection Select an input signal function of the CN10-36 pin. Refer to table 6.14 in [Pr. Po02] for setting values. This parameter setting is available with servo amplifiers with software version B7 or later.	

MR-J3-_T_			MR-J4-_A_-RJ																																																																				
No.	Name and function	Initial value	No.	Name and function	Initial value																																																																		
Po08	MR-J3-D01 output signal device selection 1 (CN10-46, 47) Any output signal can be assigned to the CN10-46, 47 pin.	2726h	Po08	MR-D01 output device selection 1 Any output device can be assigned to the CN10-46 pin and CN10-47 pin.	26h																																																																		
	__ x x: Select the output device of the CN10-46			__ x x: CN10-46 selection Select an output signal function of the CN10-46 pin. Refer to table 6.15 for settings. This parameter setting is available with servo amplifiers with software version B7 or later.																																																																			
	x x __: Select the output device of the CN10-47			x x __: CN10-47 selection Select an output signal function of the CN10-47 pin. Refer to table 7.15 for settings. This parameter setting is available with servo amplifiers with software version B7 or later.																																																																			
	The devices that can be assigned are indicated in the following table. 00: Always OFF 02: Ready (RD) 03: Trouble (ALM) 04: In position (INP) 05: Electromagnetic brake interlock (MBR) 06: Dynamic brake interlock (DB) 07: Limiting torque (TLC) 08: Warning (WNG) 09: Battery warning (BWNG) 0A: Speed command reached (SA) 0C: Zero speed (ZSP) 0F: Variable gain selection (CDPS) 23: Rough match (CPO) 24: Home position return completion (ZP) 25: Position range (POT9) 26: Temporary stop (PUS) 27: Movement finish (MEND) 38: Point table No. output 1 (PT0) 39: Point table No. output 2 (PT1) 3A: Point table No. output 3 (PT2) 3B: Point table No. output 4 (PT3) 3C: Point table No. output 5 (PT4) 3D: Point table No. output 6 (PT5) 3E: Point table No. output 7 (PT6) 3F: Point table No. output 8 (PT7) Note. The other setting values than shown in this table are for manufacturer setting.			<p style="text-align: center;">Table 6.15 Selectable output devices</p> <table border="1" style="width: 100%; border-collapse: collapse;"> <thead> <tr> <th rowspan="2">Setting value</th> <th>Output device (Note)</th> <th rowspan="2">Setting value</th> <th>Output device (Note)</th> </tr> <tr> <th>CP/BCD</th> <th>CP/BCD</th> </tr> </thead> <tbody> <tr><td>00</td><td>Always off</td><td>24</td><td>ZP</td></tr> <tr><td>02</td><td>RD</td><td>25</td><td>POT</td></tr> <tr><td>03</td><td>ALM</td><td>26</td><td>PUS</td></tr> <tr><td>04</td><td>INP</td><td>27</td><td>MEND</td></tr> <tr><td>05</td><td>MBR</td><td>2C</td><td>PED</td></tr> <tr><td>06</td><td>DB</td><td>31</td><td>ALMWNG</td></tr> <tr><td>07</td><td>TLC</td><td>32</td><td>BW9F</td></tr> <tr><td>08</td><td>WNG</td><td>38</td><td>PT0</td></tr> <tr><td>09</td><td>BWNG</td><td>39</td><td>PT1</td></tr> <tr><td>0A</td><td>SA</td><td>3A</td><td>PT2</td></tr> <tr><td>0B</td><td>Always off</td><td>3B</td><td>PT3</td></tr> <tr><td>0C</td><td>ZSP</td><td>3C</td><td>PT4</td></tr> <tr><td>0F</td><td>CDPS</td><td>3D</td><td>PT5</td></tr> <tr><td>10</td><td>CDLS</td><td>3E</td><td>PT6</td></tr> <tr><td>11</td><td>ABSV</td><td>3F</td><td>PT7</td></tr> <tr><td>23</td><td>CPO</td><td></td><td></td></tr> </tbody> </table> <p>Note. CP: Positioning mode (point table method) BCD: Positioning mode (point table method in the BCD input positioning operation) The diagonal lines indicate manufacturer settings. Never change the setting.</p>		Setting value	Output device (Note)	Setting value	Output device (Note)	CP/BCD	CP/BCD	00	Always off	24	ZP	02	RD	25	POT	03	ALM	26	PUS	04	INP	27	MEND	05	MBR	2C	PED	06	DB	31	ALMWNG	07	TLC	32	BW9F	08	WNG	38	PT0	09	BWNG	39	PT1	0A	SA	3A	PT2	0B	Always off	3B	PT3	0C	ZSP	3C	PT4	0F	CDPS	3D	PT5	10	CDLS	3E	PT6	11	ABSV	3F	PT7
Setting value	Output device (Note)	Setting value	Output device (Note)																																																																				
	CP/BCD		CP/BCD																																																																				
00	Always off	24	ZP																																																																				
02	RD	25	POT																																																																				
03	ALM	26	PUS																																																																				
04	INP	27	MEND																																																																				
05	MBR	2C	PED																																																																				
06	DB	31	ALMWNG																																																																				
07	TLC	32	BW9F																																																																				
08	WNG	38	PT0																																																																				
09	BWNG	39	PT1																																																																				
0A	SA	3A	PT2																																																																				
0B	Always off	3B	PT3																																																																				
0C	ZSP	3C	PT4																																																																				
0F	CDPS	3D	PT5																																																																				
10	CDLS	3E	PT6																																																																				
11	ABSV	3F	PT7																																																																				
23	CPO																																																																						
Po09	MR-J3-D01 output signal device selection 1 (CN10-48, 49) Any output signal can be assigned to the CN10-48, 49 pin. The devices that can be assigned and the setting method are the same as in [Pr. Po08].	0423h	Po09	MR-D01 output device selection 2 Any output device can be assigned to the CN10-48 pin and CN10-49 pin.																																																																			
	__ x x: Select the output device of the CN10-48			__ x x: CN10-48 selection Select an output signal function of the CN10-48 pin. Refer to table 6.15 in [Pr. Po08] for settings. This parameter setting is available with servo amplifiers with software version B7 or later.	23h																																																																		
	x x __: Select the output device of the CN10-49			x x __: CN10-49 selection Select an output signal function of the CN10-49 pin. Refer to table 6.15 in [Pr. Po08] for settings. This parameter setting is available with servo amplifiers with software version B7 or later.	04h																																																																		

MR-J3-_T_			MR-J4-_A_-RJ																																																																																	
No.	Name and function	Initial value	No.	Name and function	Initial value																																																																															
Po10	<p>Function selection O-1 Select the positioning operation by point table selection and BCD input.</p> <p>__ 0 x:</p> <table border="1"> <thead> <tr> <th rowspan="2">CN10 pin No.</th> <th colspan="3">Setting value</th> </tr> <tr> <th>0</th> <th>1</th> <th>2</th> </tr> </thead> <tbody> <tr> <td>1</td> <td>Devices not assigned</td> <td>DI0</td> <td>POS00</td> </tr> <tr> <td>2</td> <td></td> <td>DI1</td> <td>POS01</td> </tr> <tr> <td>3</td> <td></td> <td>DI2</td> <td>POS02</td> </tr> <tr> <td>4</td> <td></td> <td>DI3</td> <td>POS03</td> </tr> <tr> <td>5</td> <td></td> <td>DI4</td> <td>POS10</td> </tr> <tr> <td>6</td> <td></td> <td>DI5</td> <td>POS11</td> </tr> <tr> <td>7</td> <td></td> <td>DI6</td> <td>POS12</td> </tr> <tr> <td>8</td> <td></td> <td>DI7</td> <td>POS13</td> </tr> <tr> <td>9</td> <td></td> <td></td> <td>POS20</td> </tr> <tr> <td>10</td> <td></td> <td></td> <td>POS21</td> </tr> <tr> <td>11</td> <td></td> <td></td> <td>POS22</td> </tr> <tr> <td>12</td> <td></td> <td></td> <td>POS23</td> </tr> <tr> <td>15</td> <td></td> <td></td> <td>POSP</td> </tr> <tr> <td>16</td> <td></td> <td></td> <td>POSN</td> </tr> <tr> <td>17</td> <td></td> <td></td> <td>STRB (Note)</td> </tr> <tr> <td>18</td> <td></td> <td></td> <td>SP0</td> </tr> <tr> <td>19</td> <td></td> <td></td> <td>SP1</td> </tr> <tr> <td>20</td> <td></td> <td></td> <td>SP2</td> </tr> </tbody> </table> <p>Note. When using the strobe input (STRB), set the fourth digit of this parameter in "0 ___".</p> <p>_ x 0_: Symbol (+/-)of the positioning data in the BCD positioning 0: Disabled +/- symbol is not used. 1: Enabled +/- symbol is used.</p> <p>x _ 0_: Strobe signal 0: Enabled For the BCD input by the programmable controller 2: Disabled For the point table or MR-DS60 digital switch</p>	CN10 pin No.	Setting value			0	1	2	1	Devices not assigned	DI0	POS00	2		DI1	POS01	3		DI2	POS02	4		DI3	POS03	5		DI4	POS10	6		DI5	POS11	7		DI6	POS12	8		DI7	POS13	9			POS20	10			POS21	11			POS22	12			POS23	15			POSP	16			POSN	17			STRB (Note)	18			SP0	19			SP1	20			SP2	2101h	Po10	<p>Function selection O-1 Always set this parameter when using MR-D01. Set the MR-D01 input device selection, select whether to enable or disable position data input signs, and set a data establishment condition.</p> <p>___ x: MR-D01 DI0 to DI14 input signal device selection 0: Disabled 1: Point table: 255 points 2: BCD 3 digits × 2 inputs This parameter setting is available with servo amplifiers with software version B7 or later.</p> <p>__ x_: For manufacturer setting</p> <p>_ x __: MR-D01 position data input sign +/- 0: Disabled 1: Enabled This parameter setting is available with servo amplifiers with software version B7 or later.</p> <p>x ___: MR-D01 data establishment condition 0: Strobe signal enabled (when the PLC is used) 2: 3.55 ms data matching time (Strobe signal disabled) This parameter setting is available with servo amplifiers with software version B7 or later.</p>	1h 0h 0h 2h
CN10 pin No.	Setting value																																																																																			
	0	1	2																																																																																	
1	Devices not assigned	DI0	POS00																																																																																	
2		DI1	POS01																																																																																	
3		DI2	POS02																																																																																	
4		DI3	POS03																																																																																	
5		DI4	POS10																																																																																	
6		DI5	POS11																																																																																	
7		DI6	POS12																																																																																	
8		DI7	POS13																																																																																	
9			POS20																																																																																	
10			POS21																																																																																	
11			POS22																																																																																	
12			POS23																																																																																	
15			POSP																																																																																	
16			POSN																																																																																	
17			STRB (Note)																																																																																	
18			SP0																																																																																	
19			SP1																																																																																	
20			SP2																																																																																	
Po12	<p>Function selection O-3 Set the output of the alarm code and M code.</p> <p>0 0 _ x: Alarm code output 0: Disabled Alarm code is not output. 1: Enabled Alarm code is output at alarm occurrence.</p> <p>0 0 x _: M code output 0: Disabled M code is not output. 1: Enabled M code is output after execution of point table.</p>	0000h	Po12	<p>Function selection O-3 Select an alarm code output setting and an M code output setting.</p> <p>___ x: MR-D01 alarm code output 0: Disabled 1: Enabled Selecting "1" in this digit will output an alarm code when an alarm occurs. This parameter setting is available with servo amplifiers with software version B7 or later.</p> <p>__ x _: M code output selection 0: Disabled 1: Enabled Selecting "1" in this digit will enable you to check outputs according to M codes (0 to 99) set with point tables by using output devices of the communication function.</p> <p>_ x __: For manufacturer setting</p> <p>x ___: For manufacturer setting</p>	0h 0h 0h 0h																																																																															

MR-J3-_T_			MR-J4-_A_-RJ																																
No.	Name and function	Initial value	No.	Name and function	Initial value																														
Po13	<p>MR-J3-D01 analog monitor 1 output Used to selection the signal provided to the analog monitor 1</p> <p>0 0 0 x: Analog monitor 1 (MO1) output selection 0: Servo motor speed (± 8 V/max. speed) 1: Torque (± 8 V/max. torque) 2: Servo motor speed (+8 V/max. speed) 3: Torque (+8 V/max. torque) 4: Current command (+8 V/max. current command) 5: Speed command (+8 V/max. speed) 6: Droop pulses (± 10 V/100 pulses) 7: Droop pulses (± 10 V/1000 pulses) 8: Droop pulses (± 10 V/10000 pulses) 9: Droop pulses (± 10 V/100000 pulses) A: Feedback position (± 10 V/1 Mpulse) B: Feedback position (± 10 V/10 Mpulses) C: Feedback position (± 10 V/100 Mpulses) D: Bus voltage (+8 V/400 V)</p>	0000h	Po13	<p>MR-D01 analog monitor 1 output selection Set a signal to output to Analog monitor 1.</p> <p>__ x x: Analog monitor 1 output selection Refer to table 6.16 for settings. This parameter setting is available with servo amplifiers with software version B7 or later.</p> <p>_ x __: For manufacturer setting</p> <p>x __ __: For manufacturer setting</p> <p>Table 6.16 Analog monitor setting value</p> <table border="1"> <thead> <tr> <th>Setting value</th> <th>Item</th> </tr> </thead> <tbody> <tr> <td>__ 0 0</td> <td>servo motor speed (± 8 V/max. speed)</td> </tr> <tr> <td>__ 0 1</td> <td>Torque (± 8 V/max. torque) (Note 2)</td> </tr> <tr> <td>__ 0 2</td> <td>servo motor speed (+8 V/max. speed)</td> </tr> <tr> <td>__ 0 3</td> <td>Torque (+8 V/max. torque) (Note 2)</td> </tr> <tr> <td>__ 0 4</td> <td>Current command (± 8 V/max. current command)</td> </tr> <tr> <td>__ 0 5</td> <td>Command pulse frequency (± 10 V/± 4 Mpulses/s)</td> </tr> <tr> <td>__ 0 6</td> <td>Servo motor-side droop pulses (± 10 V/100 pulses) (Note 1)</td> </tr> <tr> <td>__ 0 7</td> <td>Servo motor-side droop pulses (± 10 V/1000 pulses) (Note 1)</td> </tr> <tr> <td>__ 0 8</td> <td>Servo motor-side droop pulses (± 10 V/10000 pulses) (Note 1)</td> </tr> <tr> <td>__ 0 9</td> <td>Servo motor-side droop pulses (± 10 V/100000 pulses) (Note 1)</td> </tr> <tr> <td>__ 0 A</td> <td>Feedback position (± 10 V/1 Mpulses) (Note 1)</td> </tr> <tr> <td>__ 0 B</td> <td>Feedback position (± 10 V/10 Mpulses) (Note 1)</td> </tr> <tr> <td>__ 0 C</td> <td>Feedback position (± 10 V/100 Mpulses) (Note 1)</td> </tr> <tr> <td>__ 0 D</td> <td>Bus voltage (200 V class and 100 V class: +8 V/400 V, 400 V class: +8 V/800 V)</td> </tr> </tbody> </table> <p>Note 1. Encoder pulse unit 2. 8 V is outputted at the maximum torque. However, when [Pr. PA11] and [Pr. PA12] are set to limit torque, 8 V is output at the torque highly limited.</p>	Setting value	Item	__ 0 0	servo motor speed (± 8 V/max. speed)	__ 0 1	Torque (± 8 V/max. torque) (Note 2)	__ 0 2	servo motor speed (+8 V/max. speed)	__ 0 3	Torque (+8 V/max. torque) (Note 2)	__ 0 4	Current command (± 8 V/max. current command)	__ 0 5	Command pulse frequency (± 10 V/ ± 4 Mpulses/s)	__ 0 6	Servo motor-side droop pulses (± 10 V/100 pulses) (Note 1)	__ 0 7	Servo motor-side droop pulses (± 10 V/1000 pulses) (Note 1)	__ 0 8	Servo motor-side droop pulses (± 10 V/10000 pulses) (Note 1)	__ 0 9	Servo motor-side droop pulses (± 10 V/100000 pulses) (Note 1)	__ 0 A	Feedback position (± 10 V/1 Mpulses) (Note 1)	__ 0 B	Feedback position (± 10 V/10 Mpulses) (Note 1)	__ 0 C	Feedback position (± 10 V/100 Mpulses) (Note 1)	__ 0 D	Bus voltage (200 V class and 100 V class: +8 V/400 V, 400 V class: +8 V/800 V)	00h
Setting value	Item																																		
__ 0 0	servo motor speed (± 8 V/max. speed)																																		
__ 0 1	Torque (± 8 V/max. torque) (Note 2)																																		
__ 0 2	servo motor speed (+8 V/max. speed)																																		
__ 0 3	Torque (+8 V/max. torque) (Note 2)																																		
__ 0 4	Current command (± 8 V/max. current command)																																		
__ 0 5	Command pulse frequency (± 10 V/ ± 4 Mpulses/s)																																		
__ 0 6	Servo motor-side droop pulses (± 10 V/100 pulses) (Note 1)																																		
__ 0 7	Servo motor-side droop pulses (± 10 V/1000 pulses) (Note 1)																																		
__ 0 8	Servo motor-side droop pulses (± 10 V/10000 pulses) (Note 1)																																		
__ 0 9	Servo motor-side droop pulses (± 10 V/100000 pulses) (Note 1)																																		
__ 0 A	Feedback position (± 10 V/1 Mpulses) (Note 1)																																		
__ 0 B	Feedback position (± 10 V/10 Mpulses) (Note 1)																																		
__ 0 C	Feedback position (± 10 V/100 Mpulses) (Note 1)																																		
__ 0 D	Bus voltage (200 V class and 100 V class: +8 V/400 V, 400 V class: +8 V/800 V)																																		
Po14	<p>MR-J3-D01 analog monitor 2 output Used to selection the signal provided to the analog monitor 2 (MO2) output.</p> <p>0 0 0 x: Select the analog monitor 2 (MO2) output The settings are the same as those of [Pr. Po13].</p>	0001h	Po14	<p>MR-D01 analog monitor 2 output selection Set a signal to output to Analog monitor 2.</p> <p>__ x x: Analog monitor 2 output selection Select a signal to output to MO2 (Analog monitor 2). Refer to [Pr. Po13] for settings. This parameter setting is available with servo amplifiers with software version B7 or later.</p> <p>_ x __: For manufacturer setting</p> <p>x __ __: For manufacturer setting</p>	0h																														

Part 6: Review on Replacement of MR-J3-_T_(DIO command/ Serial communication operation) with MR-J4-_A_-RJ

MR-J3-_T_			MR-J4-_A_-RJ		
No.	Name and function	Initial value	No.	Name and function	Initial value
Po15	MR-J3-D01 analog monitor 1 offset Used to set the offset voltage of the analog monitor (MO1).	0	Po15	MR-D01 analog monitor 1 offset This is used to set the offset voltage of MO1 (Analog monitor 1). This parameter setting is available with servo amplifiers with software version B7 or later. Setting range: -9999 to 9999	0
Po16	MR-J3-D01 analog monitor 2 offset Used to set the offset voltage of the analog monitor (MO2).	0	Po16	MR-D01 analog monitor 2 offset This is used to set the offset voltage of MO2 (Analog monitor 2). This parameter setting is available with servo amplifiers with software version B7 or later. Setting range: -9999 to 9999	0
Po21	MR-J3-D01 override offset Used to set the offset voltage of the override (VC).	0	Po21	MR-D01 override offset This is used to set the offset voltage of the override. This parameter setting is available with servo amplifiers with software version B7 or later. Setting range: -9999 to 9999	0
Po22	MR-J3-D01 analog torque limit offset Used to set the offset voltage of the analog torque limit (TLA).	0	Po22	MR-D01 Analog torque limit offset This is used to set the offset voltage of the analog torque limit. This parameter setting is available with servo amplifiers with software version B7 or later. Setting range: -9999 to 9999	0

3.7 Important Points for Replacement

1. SUMMARY

This section describes the precautions for setting parameters for the replacement of MR-J3-_T_ with MR-J4-_A_-RJ. For details on the parameters of MR-J3-_T_, refer to "MR-J3-_T_/MR-J3-D01 Servo Amplifier Instruction Manual".

2. Precautions

We recommend that you use the parameter converter function (supported from version 1.12N or later) of MR Configurator2 for the replacement of MR-J3-_T_ with MR-J4-_A_-RJ. The following describes the parameters that are easily missed when the parameter setting is manually changed.

(1) [Pr. PC16 Electromagnetic brake sequence output]

MR-J3-_T_ and MR-J4-_A_-RJ have different initial values for [Pr.PC16] (MR-J3-_T_: 100 ms, MR-J4-_A_-RJ:0 ms). When MBR (Electromagnetic brake interlock) is assigned for [Pr. PD23] to [Pr. PD26] and [Pr. PD28], refer to the "MR-J4-_A_-(-RJ)/MR-J4-03A6(-RJ) Servo Amplifier Instruction Manual" and then set [Pr.PC16].

No./symbol/ name	Setting digit	Function	Initial Value [unit]
PC16 MBR Electromagnetic brake sequence output		Set the delay time between MBR (Electromagnetic brake interlock) and the base drive circuit is shut-off. Setting range: 0 to 1000	0 [ms]

(2) Speed command input unit selection (__ x __) of [Pr. PC29 Function selection C-8]

The parameter number and digit are different between MR-J3-_T_ and MR-J4-_A_-RJ.

No./symbol/ name	Setting digit	Function	Initial Value [unit]									
PC29 *COP8 Function selection C-8	___x	For manufacturer setting	0h									
	__x__	Speed command input unit selection Select the setting units of [Pr. PC05] to [Pr. PC11], [Pr. PT05], [Pr. PT06], and [Pr. PT13].	0h									
	<table border="1"> <thead> <tr> <th>Setting value</th> <th>MR-J3-_T_ [Pr. PA05]: " _ x _ "</th> <th>MR-J4-_A_-RJ [Pr. PC29]: " __ x __ "</th> </tr> </thead> <tbody> <tr> <td>0</td> <td>1 r/min Unit</td> <td>1 r/min Unit</td> </tr> <tr> <td>1</td> <td>0.1 r/min Unit</td> <td>0.1 r/min Unit</td> </tr> </tbody> </table>			Setting value	MR-J3-_T_ [Pr. PA05]: " _ x _ "	MR-J4-_A_-RJ [Pr. PC29]: " __ x __ "	0	1 r/min Unit	1 r/min Unit	1	0.1 r/min Unit	0.1 r/min Unit
	Setting value	MR-J3-_T_ [Pr. PA05]: " _ x _ "	MR-J4-_A_-RJ [Pr. PC29]: " __ x __ "									
0	1 r/min Unit	1 r/min Unit										
1	0.1 r/min Unit	0.1 r/min Unit										
Setting "1" will display "servo motor speed" in units of 0.1 r/min.												
	_x__	For manufacturer setting	0h									
	x___	For manufacturer setting	0h									

(3) Input signal filter selection (_ _ _ x) of [Pr. PD29 Input filter setting]
 MR-J3-_T_ and MR-J4-_A_-RJ have different initial values for the input signal filter selection.

No./symbol/ name	Setting digit	Function	Initial value [unit]																								
PD29 *DIF Input filter setting	Select a filter for the input signal.																										
	_ _ _ x	Input signal filter selection If external input signal causes chattering due to noise, etc., input filter is used to suppress it. <table border="1" style="margin: 10px auto;"> <thead> <tr> <th>Setting value</th> <th>MR-J3-_T_ [Pr. PD19]</th> <th>MR-J4-_A_-RJ [Pr. PD29]</th> </tr> </thead> <tbody> <tr> <td>0</td> <td>None</td> <td>None</td> </tr> <tr> <td>1</td> <td>0.888 [ms]</td> <td>0.888 [ms]</td> </tr> <tr> <td>2</td> <td>1.777 [ms] (Initial value)</td> <td>1.777 [ms]</td> </tr> <tr> <td>3</td> <td>2.666 [ms]</td> <td>2.666 [ms]</td> </tr> <tr> <td>4</td> <td>3.555 [ms]</td> <td>3.555 [ms] (Initial value)</td> </tr> <tr> <td>5</td> <td>4.444 [ms]</td> <td>4.444 [ms]</td> </tr> <tr> <td>6</td> <td></td> <td>5.333 [ms]</td> </tr> </tbody> </table>	Setting value	MR-J3-_T_ [Pr. PD19]	MR-J4-_A_-RJ [Pr. PD29]	0	None	None	1	0.888 [ms]	0.888 [ms]	2	1.777 [ms] (Initial value)	1.777 [ms]	3	2.666 [ms]	2.666 [ms]	4	3.555 [ms]	3.555 [ms] (Initial value)	5	4.444 [ms]	4.444 [ms]	6		5.333 [ms]	4h
	Setting value	MR-J3-_T_ [Pr. PD19]	MR-J4-_A_-RJ [Pr. PD29]																								
	0	None	None																								
1	0.888 [ms]	0.888 [ms]																									
2	1.777 [ms] (Initial value)	1.777 [ms]																									
3	2.666 [ms]	2.666 [ms]																									
4	3.555 [ms]	3.555 [ms] (Initial value)																									
5	4.444 [ms]	4.444 [ms]																									
6		5.333 [ms]																									
_ _ x _	RES (Reset) dedicated filter selection 0: Disabled 1: Enabled (50 [ms]) This digit is not available with MR-J3-_T_.	0h																									
_ x _ _	CR (Clear) dedicated filter selection 0: Disabled 1: Enabled (50 [ms]) This digit is not available with MR-J3-_T_.	0h																									
x _ _ _	For manufacturer setting	0h																									

(4) Base circuit status selection for RES (Reset) on (_ _ x _) of [Pr. PD30 Function selection D-1]
 MR-J3-_T_ and MR-J4-_A_-RJ have different initial values for base circuit status selection for RES (Reset) on.

No./symbol/ name	Setting digit	Function	Initial value [unit]															
PD30 *DOP1 Function selection D-1	___x	Stop method selection for LSP (Forward rotation stroke end) off or LSN (Reverse rotation stroke end) off Select a stop method for LSP (Forward rotation stroke end) off or LSN (Reverse rotation stroke end) off. <table border="1" style="margin: 10px auto;"> <thead> <tr> <th>Setting value</th> <th>MR-J3-_T_ [Pr. PD20]</th> <th>MR-J4-_A_-RJ [Pr. PD30]</th> </tr> </thead> <tbody> <tr> <td>0</td> <td>Quick stop (home position erased) (Initial value)</td> <td>Quick stop (home position erased) (Initial value)</td> </tr> <tr> <td>1</td> <td>Slow stop (home position erased)</td> <td>Slow stop (home position erased)</td> </tr> <tr> <td>2</td> <td>Slow stop (deceleration to a stop by deceleration time constant)</td> <td>Slow stop (deceleration to a stop by deceleration time constant)</td> </tr> <tr> <td>3</td> <td>Quick stop (stop by clearing remaining distance)</td> <td>Quick stop (stop by clearing remaining distance)</td> </tr> </tbody> </table>	Setting value	MR-J3-_T_ [Pr. PD20]	MR-J4-_A_-RJ [Pr. PD30]	0	Quick stop (home position erased) (Initial value)	Quick stop (home position erased) (Initial value)	1	Slow stop (home position erased)	Slow stop (home position erased)	2	Slow stop (deceleration to a stop by deceleration time constant)	Slow stop (deceleration to a stop by deceleration time constant)	3	Quick stop (stop by clearing remaining distance)	Quick stop (stop by clearing remaining distance)	0h
	Setting value	MR-J3-_T_ [Pr. PD20]	MR-J4-_A_-RJ [Pr. PD30]															
	0	Quick stop (home position erased) (Initial value)	Quick stop (home position erased) (Initial value)															
	1	Slow stop (home position erased)	Slow stop (home position erased)															
2	Slow stop (deceleration to a stop by deceleration time constant)	Slow stop (deceleration to a stop by deceleration time constant)																
3	Quick stop (stop by clearing remaining distance)	Quick stop (stop by clearing remaining distance)																
__x_	Base circuit status selection for RES (Reset) on <table border="1" style="margin: 10px auto;"> <thead> <tr> <th>Setting value</th> <th>MR-J3-_T_ [Pr. PD20]</th> <th>MR-J4-_A_-RJ [Pr. PD30]</th> </tr> </thead> <tbody> <tr> <td>0</td> <td>Base circuit shut-off</td> <td>Base circuit shut-off (Initial value)</td> </tr> <tr> <td>1</td> <td>No base circuit shut-off (Initial value)</td> <td>No base circuit shut-off</td> </tr> </tbody> </table>	Setting value	MR-J3-_T_ [Pr. PD20]	MR-J4-_A_-RJ [Pr. PD30]	0	Base circuit shut-off	Base circuit shut-off (Initial value)	1	No base circuit shut-off (Initial value)	No base circuit shut-off	0h							
Setting value	MR-J3-_T_ [Pr. PD20]	MR-J4-_A_-RJ [Pr. PD30]																
0	Base circuit shut-off	Base circuit shut-off (Initial value)																
1	No base circuit shut-off (Initial value)	No base circuit shut-off																
_x__	Stop method selection at software limit detection <table border="1" style="margin: 10px auto;"> <thead> <tr> <th>Setting value</th> <th>MR-J3-_T_ [Pr. PD20]</th> <th>MR-J4-_A_-RJ [Pr. PD30]</th> </tr> </thead> <tbody> <tr> <td>0</td> <td>Quick stop (home position erased) (Initial value)</td> <td>Quick stop (home position erased) (Initial value)</td> </tr> <tr> <td>1</td> <td>Slow stop (home position erased)</td> <td>Slow stop (home position erased)</td> </tr> <tr> <td>2</td> <td>Slow stop (deceleration to a stop by deceleration time constant)</td> <td>Slow stop (deceleration to a stop by deceleration time constant)</td> </tr> <tr> <td>3</td> <td>Quick stop (stop by clearing remaining distance)</td> <td>Quick stop (stop by clearing remaining distance)</td> </tr> </tbody> </table>	Setting value	MR-J3-_T_ [Pr. PD20]	MR-J4-_A_-RJ [Pr. PD30]	0	Quick stop (home position erased) (Initial value)	Quick stop (home position erased) (Initial value)	1	Slow stop (home position erased)	Slow stop (home position erased)	2	Slow stop (deceleration to a stop by deceleration time constant)	Slow stop (deceleration to a stop by deceleration time constant)	3	Quick stop (stop by clearing remaining distance)	Quick stop (stop by clearing remaining distance)	0h	
Setting value	MR-J3-_T_ [Pr. PD20]	MR-J4-_A_-RJ [Pr. PD30]																
0	Quick stop (home position erased) (Initial value)	Quick stop (home position erased) (Initial value)																
1	Slow stop (home position erased)	Slow stop (home position erased)																
2	Slow stop (deceleration to a stop by deceleration time constant)	Slow stop (deceleration to a stop by deceleration time constant)																
3	Quick stop (stop by clearing remaining distance)	Quick stop (stop by clearing remaining distance)																
x___	Enabled/disabled selection for a thermistor of servo motor <table border="1" style="margin: 10px auto;"> <thead> <tr> <th>Setting value</th> <th>MR-J3-_T_ [Pr. PD20]</th> <th>MR-J4-_A_-RJ [Pr. PD30]</th> </tr> </thead> <tbody> <tr> <td>0</td> <td>Fixed to 0</td> <td>Enabled</td> </tr> <tr> <td>1</td> <td>Fixed to 0</td> <td>Disabled</td> </tr> </tbody> </table> <p>This digit is not available with MR-J3-_T_.</p>	Setting value	MR-J3-_T_ [Pr. PD20]	MR-J4-_A_-RJ [Pr. PD30]	0	Fixed to 0	Enabled	1	Fixed to 0	Disabled	0h							
Setting value	MR-J3-_T_ [Pr. PD20]	MR-J4-_A_-RJ [Pr. PD30]																
0	Fixed to 0	Enabled																
1	Fixed to 0	Disabled																

4. COMMUNICATION FUNCTION

You can operate servo driving, parameter change, monitor function, etc. using RS-422 communication with the servo amplifier.

4.1 Command and data No. list

POINT
● Even if a command or data No. is the same between different model servo amplifiers, its description may differ.

4.1.1 Reading command comparison between MR-J3-_T_ and MR-J4-_A_-RJ ([Pr. PT01]: "1___")

POINT
● When [Pr. PT01] is set to "1___", MR Configurator2 is not available using USB communication.

The functions added to the MR-J4-_A_-RJ series are not listed. Refer to the "MR-J4-_A_-RJ/MR-J4-03A6-RJ Servo Amplifier Instruction Manual (Positioning mode)" for details.

(1) Status display (Command [0] [1])

Command	Data No.	Description	MR-J3-_T_		MR-J4-_A_-RJ [Pr. PT01]: "1___"					
			Status display	Frame length	Status display	Frame length				
[0] [1]	[0] [0]	Status display symbol and unit	Current position	16	Current position	16				
	[0] [1]		Command position		Command position					
	[0] [2]		Command remaining distance		Command remaining distance					
	[0] [3]		Point table No.		Point table No.					
	[0] [4]		Cumulative feedback pulses		Cumulative feedback pulses					
	[0] [5]		Servo motor speed		Servo motor speed					
	[0] [6]		Droop pulses		Droop pulses					
	[0] [7]		Analog override voltage		Analog override voltage					
	[0] [8]		Override level		Override level					
	[0] [9]		Analog torque limit voltage		Analog torque limit voltage					
	[0] [A]		Regenerative load ratio		Regenerative load ratio					
	[0] [B]		Effective load ratio		Effective load ratio					
	[0] [C]		Peak load ratio		Peak load ratio					
	[0] [D]		Instantaneous torque		Instantaneous torque					
	[0] [E]		Position within onerevolution		Position within onerevolution					
	[0] [F]		ABS counter		ABS counter					
	[1] [0]		Load to motor inertia ratio		Load to motor inertia ratio					
	[1] [1]		Bus voltage		Bus voltage					
	[8] [0]		[8] [0]		Status display data value and processing information		Current position	12	Current position	12
			[8] [1]				Command position		Command position	
[8] [2]		Command remaining distance	Command remaining distance							
[8] [3]		Point table No.	Point table No.							
[8] [4]		Cumulative feedback pulses	Cumulative feedback pulses							
[8] [5]		Servo motor speed	Servo motor speed							
[8] [6]		Droop pulses	Droop pulses							
[8] [7]		Analog override voltage	Analog override voltage							
[8] [8]		Override level	Override level							
[8] [9]		Analog torque limit voltage	Analog torque limit voltage							
[8] [A]		Regenerative load ratio	Regenerative load ratio							
[8] [B]		Effective load ratio	Effective load ratio							

Part 6: Review on Replacement of MR-J3-_T_(DIO command/ Serial communication operation) with MR-J4-_A_-RJ

Command	Data No.	Description	MR-J3-_T_		MR-J4-_A_-RJ [Pr. PT01]: "1___"	
			Status display	Frame length	Status display	Frame length
[0] [1]	[8] [C]	Status display data value and processing information	Peak load ratio	12	Peak load ratio	12
	[8] [D]		Instantaneous torque		Instantaneous torque	
	[8] [E]		Position within onerevolution		Position within onerevolution	
	[8] [F]		ABS counter		ABS counter	
	[9] [0]		Load to motor inertia ratio		Load to motor inertia ratio	
	[9] [1]		Bus voltage		Bus voltage	

(2) Parameters (Command [0] [4]/[0] [5]/[0] [6]/[0] [7]/[0] [8]/[0] [9])

Command	Data No.	MR-J3-_T_		MR-J4-_A_-RJ [Pr. PT01]: "1_ _ _"	
		Description	Frame length	Description	Frame length
[0] [4]	[0] [1]	Parameter group read 0000: Basic setting parameter ([Pr. PA_ _]) 0001: Gain filter parameter ([Pr. PB_ _]) 0002: Extension setting parameter ([Pr. PC_ _]) 0003: I/O setting parameter ([Pr. PD_ _]) 0009: Option setting parameter ([Pr. Po_ _])	4	Parameter group read 0000: Basic setting parameter ([Pr. PA_ _]) 0001: Gain filter parameter ([Pr. PB_ _]) 0002: Extension setting parameter ([Pr. PC_ _]) 0003: I/O setting parameter ([Pr. PD_ _]) 0005: Extension setting 3 parameter ([Pr. PF_ _]) 0009: Option setting parameter ([Pr. Po_ _]) 000C: Positioning control parameter ([Pr. PT_ _]) Reads the parameter group specified with the command [8] [5] + data No. [0] [0]. Before reading the current values, therefore, always specify the parameter group with the command [8] [5] + data No. [0] [0].	4
[0] [5] (Note 1)	[0] [1] to [F] [F]	Current values of parameters The decimal equivalent of the data No. value (hexadecimal) corresponds to the parameter number. Reads the current values of the parameters in the parameter group specified with the command [8] [5] + data No. [0] [0]. Before reading the current values, therefore, always specify the parameter group with the command [8] [5] + data No. [0] [0].	8	Current value of each parameter The decimal equivalent of the data No. (hexadecimal) value corresponds to the parameter No. Reads the current values of the parameters in the parameter group specified with the command [8] [5] + data No. [0] [0]. Before reading the current values, therefore, always specify the parameter group with the command [8] [5] + data No. [0] [0].	12
[0] [6] (Note 2)	[0] [1] to [F] [F]	Upper limit values of parameter setting ranges The decimal equivalent of the data No. value (hexadecimal) corresponds to the parameter number. Reads the permissible upper limit values of the parameters in the parameter group specified with the command [8] [5] + data No. [0] [0]. Before reading the upper limit values, therefore, always specify the parameter group with the command [8] [5] + data No. [0] [0].	8	Upper limit value of each parameter setting range The decimal equivalent of the data No. (hexadecimal) value corresponds to the parameter No. Reads the permissible upper limit values of the parameters in the parameter group specified with the command [8] [5] + data No. [0] [0]. Before reading the upper limit values, therefore, always specify the parameter group with the command [8] [5] + data No. [0] [0].	12
[0] [7] (Note 3)	[0] [1] to [F] [F]	Lower limit values of parameter setting range The decimal equivalent of the data No. value (hexadecimal) corresponds to the parameter number. Reads the permissible lower limit values of the parameters in the parameter group specified with the command [8] [5] + data No. [0] [0]. Before reading the lower limit values, therefore, always specify the parameter group with the command [8] [5] + data No. [0] [0].	8	Lower limit value of each parameter setting range The decimal equivalent of the data No. (hexadecimal) value corresponds to the parameter No. Reads the permissible lower limit values of the parameters in the parameter group specified with the command [8] [5] + data No. [0] [0]. Before reading the lower limit values, therefore, always specify the parameter group with the command [8] [5] + data No. [0] [0].	12
[0] [8]	[0] [1] to [F] [F]	Abbreviations of parameters The decimal equivalent of the data No. value (hexadecimal) corresponds to the parameter number. Reads the abbreviations of the parameters in the parameter group specified with the command [8] [5] + data No. [0] [0]. Before reading the abbreviations, therefore, always specify the parameter group with the command [8] [5] + data No. [0] [0].	12	Each parameter symbol The decimal equivalent of the data No. (hexadecimal) value corresponds to the parameter No. Reads the symbols of the parameters in the parameter group specified with the command [8] [5] + data No. [0] [0]. Before reading the symbols, therefore, always specify the parameter group with the command [8] [5] + data No. [0] [0].	12
[0] [9]	[0] [1] to [F] [F]	Write enable/disable of parameters 0000: Write enabled 0001: Write disabled Reads write enable/disable of the parameters in the parameter group specified with the command [8] [5] + data No. [0] [0]. Before reading write enable/disable, therefore, always specify the parameter group with the command [8] [5] + data No. [0] [0].	4	Writing enable/disable of parameters 0000: Writing enabled 0001: Writing disabled Reads writing enable/disable of the parameters in the parameter group specified with the command [8] [5] + data No. [0] [0]. Before reading writing enable/disable, therefore, always specify the parameter group with the command [8] [5] + data No. [0] [0].	4

Note 1. For MR-J4-_A_-RJ, the command is [1] [5].
 2. For MR-J4-_A_-RJ, the command is [1] [6].
 3. For MR-J4-_A_-RJ, the command is [1] [7].

(3) External I/O signals (Command [1] [2])

Command	Data No.	MR-J3-_T_		MR-J4-_A_-RJ [Pr. PT01]: "1_ _ _"	
		Description	Frame length	Description	Frame length
[1] [2]	[0] [0]	Input device status	8	Input device status	8
	[0] [1]				
	[0] [2]				
	[4] [0]	External input pin status			
	[4] [1]				
	[6] [0]	Status of input device turned on by communication			
	[6] [1]				
	[6] [2]				
	[8] [0]	Output device status			
	[8] [1]				
	[8] [2]				
	[8] [3]	External output pin status			
	[C] [0]				
[C] [1]					

(4) Alarm history (Command [3] [3])

Command	Data No.	Description	MR-J3-_T_		MR-J4-_A_-RJ [Pr. PT01]: "1_ _ _"	
			Alarm occurrence sequence	Frame length	Alarm occurrence sequence	Frame length
[3] [3]	[1] [0]	Alarm No. in alarm history	Most recent alarm	4	Most recent alarm	4
	[1] [1]		First alarm in past		First alarm in past	
	[1] [2]		Second alarm in past		Second alarm in past	
	[1] [3]		Third alarm in past		Third alarm in past	
	[1] [4]		Fourth alarm in past		Fourth alarm in past	
	[1] [5]		Fifth alarm in past		Fifth alarm in past	
	[2] [0]	Alarm occurrence time in alarm history	Most recent alarm	8	Most recent alarm	8
	[2] [1]		First alarm in past		First alarm in past	
	[2] [2]		Second alarm in past		Second alarm in past	
	[2] [3]		Third alarm in past		Third alarm in past	
	[2] [4]		Fourth alarm in past		Fourth alarm in past	
[2] [5]	Fifth alarm in past	Fifth alarm in past				

(5) Current alarm (Command [0] [2])

Command	Data No.	MR-J3-_T_		MR-J4-_A_-RJ [Pr. PT01]: "1_ _ _"	
		Description	Frame length	Description	Frame length
[0] [2]	[0] [0]	Current alarm No.	4	Current alarm No.	4

(6) Status display at alarm occurrence (Command [3] [5])

Command	Data No.	Description	MR-J3-_T_		MR-J4-_A_-RJ [Pr. PT01]: "1_ _ _"	
			Alarm occurrence sequence	Frame length	Alarm occurrence sequence	Frame length
[3] [5]	[8] [0]	Status display data value and processing information	Current position	12	Current position	12
	[8] [1]		Command position		Command position	
	[8] [2]		Command remaining distance		Command remaining distance	
	[8] [3]		Point table No.		Point table No.	
	[8] [4]		Cumulative feedback pulses		Cumulative feedback pulses	
	[8] [5]		Servo motor speed		Servo motor speed	
	[8] [6]		Droop pulses		Droop pulses	
	[8] [7]		Analog override voltage		Analog override voltage	
	[8] [8]		Override level		Override level	
	[8] [9]		Analog torque limit voltage		Analog torque limit voltage	
	[8] [A]		Regenerative load ratio		Regenerative load ratio	
	[8] [B]		Effective load ratio		Effective load ratio	
	[8] [C]		Peak load ratio		Peak load ratio	
	[8] [D]		Instantaneous torque		Instantaneous torque	
	[8] [E]		Position within onerevolution		Position within onerevolution	
	[8] [F]		ABS counter		ABS counter	
	[9] [0]		Load to motor inertia ratio		Load to motor inertia ratio	
[9] [1]	Bus voltage	Bus voltage				

(7) Point table (Command [4] [0]/[5] [0]/[5] [4]/[5] [8]/[6] [0]/[6] [4]/[4] [5])

The decimal equivalent of the data No. (hexadecimal) value corresponds to the parameter No.

Command	Data No.	MR-J3-_T_		MR-J4-_A_-RJ [Pr. PT01]: "1_ _ _"	
		Description	Frame length	Description	Frame length
[4] [0]	[0] [1] to [F] [F]	Reading position data of each point table	8	Reading position data of each point table	8
[5] [0]	[0] [1] to [F] [F]	Reading speed data of each point table	8	Reading speed data of each point table	8
[5] [4]	[0] [1] to [F] [F]	Reading acceleration time constant of each point table	8	Reading acceleration time constant of each point table	8
[5] [8]	[0] [1] to [F] [F]	Reading deceleration time constant of each point table	8	Reading deceleration time constant of each point table	8
[6] [0]	[0] [1] to [F] [F]	Reading dwell of each point table	8	Reading dwell of each point table	8
[6] [4]	[0] [1] to [F] [F]	Reading auxiliary function of each point table	8	Reading auxiliary function of each point table	8
[4] [5]	[0] [1] to [F] [F]	Reading M code of each point table	8	Reading M code of each point table	8

(8) Group setting (Command [1] [F])

Command	Data No.	MR-J3-_T_		MR-J4-_A_-RJ [Pr. PT01]: "1_ _ _"	
		Description	Frame length	Description	Frame length
[1] [F]	[0] [0]	Reading of group setting value	4	Reading of group setting value	4

(9) Others (Command [0] [0]/[0] [2])

Command	Data No.	MR-J3-_T_		MR-J4-_A_-RJ [Pr. PT01]: "1_ _ _"	
		Description	Frame length	Description	Frame length
[0] [0]	[1] [2]	Reading test operation mode 0000: Normal mode (not test operation mode) 0001: JOG operation 0002: Positioning operation 0003: Motorless operation 0004: Output signal (DO) forced output 0005: Single-step feed opera	4	Reading test operation mode 0000: Normal mode (not test operation mode) 0001: JOG operation 0002: Positioning operation 0004: Output signal (DO) forced output 0005: Single-step feed opera	4
[0] [2]	[9] [0]	Servo motor-side pulse unit absolute position	8	Servo motor-side pulse unit absolute position	8
	[9] [1]	Command unit absolute position	8	Command unit absolute position	8
	[7] [0]	Software version	16	Software version	16

4.1.2 Writing command comparison between MR-J3-_T_ and MR-J4-_A_-RJ ([Pr. PT01]: "1___")

(1) Status display (Command [8] [1])

Command	Data No.	MR-J3-_T_			MR-J4-_A_-RJ [Pr. PT01]: "1___"		
		Description	Setting range	Frame length	Description	Setting range	Frame length
[8] [1]	[0] [0]	Status display data deletion	1EA5	4	Status display data deletion	1EA5	4

(2) Parameter (Command [8] [4]/[8] [5])

Command	Data No.	MR-J3-_T_			MR-J4-_A_-RJ [Pr. PT01]: "1___"		
		Description	Setting range	Frame length	Description	Setting range	Frame length
[8] [4] (Note)	[0] [1] to [F] [F]	Write of parameters Writes the values of the parameters in the parameter group specified with the command [8] [5] + data No. [0] [0]. Before writing the values, therefore, always specify the parameter group with the command [8] [5] + data No. [0] [0]. The decimal equivalent of the data No. value (hexadecimal) corresponds to the parameter number.	Depen- ding on the param- eter	8	Writing each parameter Writes the values of the parameters in the parameter group specified with the command [8] [5] + data No. [0] [0]. Before writing the values, therefore, always specify the parameter group with the command [8] [5] + data No. [0] [0]. The decimal equivalent of the data No. (hexadecimal) value corresponds to the parameter No.	Depen- ding on the param- eter	12
[8] [5]	[0] [0]	Parameter group writing 0000: Basic setting parameters ([Pr. PA__]) 0001: Gain/filter parameters ([Pr. PB__]) 0002: Extension setting parameters ([Pr. PC__]) 0003: I/O setting parameters ([Pr. PD__]) 0009: Option setting parameters ([Pr. Po__])	0000 to 0003, 0009	4	Parameter group writing 0000: Basic setting parameters ([Pr. PA__]) 0001: Gain/filter parameters ([Pr. PB__]) 0002: Extension setting parameters ([Pr. PC__]) 0003: I/O setting parameters ([Pr. PD__]) 0004: Extension setting 2 parameters ([Pr. PE__]) 0005: Extension setting 3 parameters ([Pr. PF__]) 0009: Option setting parameters ([Pr. Po__]) 000C: Positioning control parameters ([Pr. PT__])	0000 to 000C	4

Note. For MR-J4-_A_-RJ, the command is [9] [4].

(3) External I/O signals (Command [9] [2])

Command	Data No.	MR-J3-_T_			MR-J4-_A_-RJ [Pr. PT01]: "1___"		
		Description	Setting range	Frame length	Description	Setting range	Frame length
[9] [2]	[6] [0]	Communication input device signal	(Note)	8	Communication input device signal	(Note)	8
	[6] [1]						
	[6] [2]						

Note. Differs according to the signal. Refer to each servo amplifier instruction manual for details.

(4) Alarm history (Command [8] [2])

Command	Data No.	MR-J3-_T_			MR-J4-_A_-RJ [Pr. PT01]: "1___"		
		Description	Setting range	Frame length	Description	Setting range	Frame length
[8] [2]	[2] [0]	Alarm history clear	1EA5	4	Alarm history clear	1EA5	4

(5) Current alarm (Command [8] [2])

Command	Data No.	MR-J3-_T_			MR-J4-_A_-RJ [Pr. PT01]: "1_ _ _"		
		Description	Setting range	Frame length	Description	Setting range	Frame length
[8] [2]	[0] [0]	Alarm clear	1EA5	4	Alarm clear	1EA5	4

(6) Point table (Command [C] [0]/[C] [6]/[C] [7]/[C] [8]/[C] [A]/[C] [B]/[C] [2])

The decimal equivalent of the data No. (hexadecimal) value corresponds to the parameter No.

Command	Data No.	MR-J3-_T_		MR-J4-_A_-RJ [Pr. PT01]: "1_ _ _"	
		Description	Frame length	Description	Frame length
[4] [0]	[0] [1] to [F] [F]	Reading position data of each point table	8	Reading position data of each point table	8
[5] [0]	[0] [1] to [F] [F]	Reading speed data of each point table	8	Reading speed data of each point table	8
[5] [4]	[0] [1] to [F] [F]	Reading acceleration time constant of each point table	8	Reading acceleration time constant of each point table	8
[5] [8]	[0] [1] to [F] [F]	Reading deceleration time constant of each point table	8	Reading deceleration time constant of each point table	8
[6] [0]	[0] [1] to [F] [F]	Reading dwell of each point table	8	Reading dwell of each point table	8
[6] [4]	[0] [1] to [F] [F]	Reading auxiliary function of each point table	8	Reading auxiliary function of each point table	8
[4] [5]	[0] [1] to [F] [F]	Reading M code of each point table	8	Reading M code of each point table	8

(7) I/O device prohibition (Command [9] [0])

Command	Data No.	MR-J3-_T_			MR-J4-_A_-RJ [Pr. PT01]: "1_ _ _"		
		Description	Setting range	Frame length	Description	Setting range	Frame length
[9] [0]	[0] [0]	Turns off the input devices with the exception of EMG, LSP and LSN, independently of the external ON/OFF statuses.	1EA5	4	Turns off the input device, external analog input signal, and pulse train input, except EM2, LSP and LSN, independently of the external on/off statuses.	1EA5	4
	[0] [3]	Disables all output devices (DO).	1EA5	4	Prohibits all output devices (DO).	1EA5	4
	[1] [0]	Enables the disabled input devices with the exception of EMG, LSP and LSN.	1EA5	4	Cancels the prohibition of the input device, external analog input signal and pulse train input, except EM2, LSP and LSN.	1EA5	4
	[1] [3]	Enables the disabled output devices (DO).	1EA5	4	Cancels the prohibition of the output device.	1EA5	4

(8) Operation mode selection (Command [8] [B])

Command	Data No.	MR-J3-_T_			MR-J4-_A_-RJ [Pr. PT01]: "1_ _ _"		
		Description	Setting range	Frame length	Description	Setting range	Frame length
[8] [B]	[0] [0]	Operation mode switching 0000: Test operation mode cancel 0001: JOG operation 0002: Positioning operation 0003: Motorless operation 0004: Output signal (DO) forced output 0005: Single-step feed	0000 to 0005	4	Selection of test operation mode 0000: Test operation mode cancel 0001: JOG operation 0002: Positioning operation 0004: Output signal (DO) forced output 0005: Single-step feed operation	0000 to 0002, 0004, 0005	4

(9) Test operation mode data (Command [9] [2]/[A] [0])

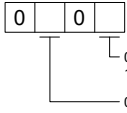
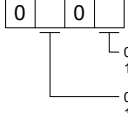
Command	Data No.	MR-J3-_T_			MR-J4-_A_-RJ [Pr. PT01]: "1_ _ _"		
		Description	Setting range	Frame length	Description	Setting range	Frame length
[9] [2]	[0] [0]	Input signal for test operation	(Note 1)	8	Input signal for test operation	(Note 2)	8
	[0] [1]						
	[0] [2]						
	[A] [0]	Forced output of signal pin		8	Forced output of signal pin		8
[A] [0]	[1] [0]	Writes the servo motor speed in the test operation mode (JOG operation and positioning operation).	0000 to 7FFF	4	Writes the acceleration/deceleration time constant in the test operation mode (JOG operation and positioning operation).	0000 to 7FFF	4
	[1] [1]	Writes the acceleration/deceleration time constant in the test operation mode (JOG operation and positioning operation).	00000000 to 7FFFFFFF	8	Writes the acceleration/deceleration time constant in the test operation mode (JOG operation and positioning operation).	00000000 to 7FFFFFFF	8
	[2] [0]	Set the travel distance of the test operation mode (positioning operation).	00000000 to 7FFFFFFF	8	Set the travel distance of the test operation mode (positioning operation).	00000000 to 7FFFFFFF	8
	[2] [1]	Select the positioning direction of the test operation (positioning operation). 	0000 to 0101	4	Select the positioning direction of the test operation (positioning operation). 	0000 to 0101	4
	[4] [0]	This is a start command of the test operation (positioning operation).	1EA5	4	This is a start command of the test operation (positioning operation).	1EA5	4
	[4] [1]	This is used to make a temporary stop during test operation (positioning operation). "□" in the data indicates a blank. STOP: Temporary stop GO□□: Restart for remaining distance CLR□: Remaining distance clear	STOP GO□□ CLR□	4	This is used to make a temporary stop during test operation (positioning operation). "□" in the data indicates a blank. STOP: Temporary stop GO□□: Restart for remaining distance CLR□: Remaining distance clear	STOP GO□□ CLR□	4

- Note 1. Refer to section 14.5.7 of "MR-J3-_T_/MR-J3-D01 Servo Amplifier Instruction Manual".
 2. Refer to section 14.5.7 of "MR-J4-_A_-RJ/MR-J4-03A6(-RJ) Servo Amplifier Instruction Manual".

(10) Group setting ([9] [F])

Command	Data No.	MR-J3-_T_			MR-J4-_A_-RJ [Pr. PT01]: "1_ _ _"		
		Description	Setting range	Frame length	Description	Setting range	Frame length
[9] [F]	[0] [0]	Setting of group	a to f	4	Setting of group	a to f	4

Part 7

Review on Replacement of MR-J3-_T_ (CC-Link communication operation) with MR-J4-_GF_

Part 7: Review on Replacement of MR-J3-_T_ (CC-Link communication operation) with MR-J4-_GF_

Part 7: Review on Replacement of MR-J3-_T_ (CC-Link communication operation) with MR-J4-_GF_

POINT
<ul style="list-style-type: none">● The existing CC-Link communication compatible controller needs to be replaced with a CC-Link IE Field Network communication compatible controller. For details on the controller, refer to the relevant controller manual.● The profile of the link device sent/received by cyclic communication with the master station is not compatible between MR-J3-_T_ and MR-J4-_GF_. Refer to each servo amplifier instruction manual for details.● This manual describes the case where MR-J3-_T_ (CC-Link communication) is used by occupying two stations. For details on the occupied stations, refer to "MR-J3-_T_ Servo Amplifier Instruction Manual".● This manual describes the case where the station-specific mode of MR-J4-_GF_ is set to "I/O mode". For details on the case where the station-specific mode is set to "Motion mode", refer to "MR-J4-_GF_(-RJ) Servo Amplifier Instruction Manual (Motion Mode)".● Use the MR-J4-_GF_ with software version B0 or later.

Part 7: Review on Replacement of MR-J3-_T_ (CC-Link communication operation) with MR-J4-_GF_

1. SUMMARY

This chapter describes the changes that are made when a system that uses MR-J3-_T_ (CC-Link communication operation) is replaced with a system that uses MR-J4-_GF_.

2. MR-J3-_T_ (CC-Link COMMUNICATION OPERATION) REPLACEMENT CASE STUDY

2.1 Examination of replacement method

POINT
<p>●The HG motor cannot be operated on MR-J3-_T_ (CC-Link communication operation). If replacing the servo motor with the HG motor, batch update to the MR-J4-_GF_ + HG motor is required.</p>

MR-J3-_T_ (CC-Link communication operation)

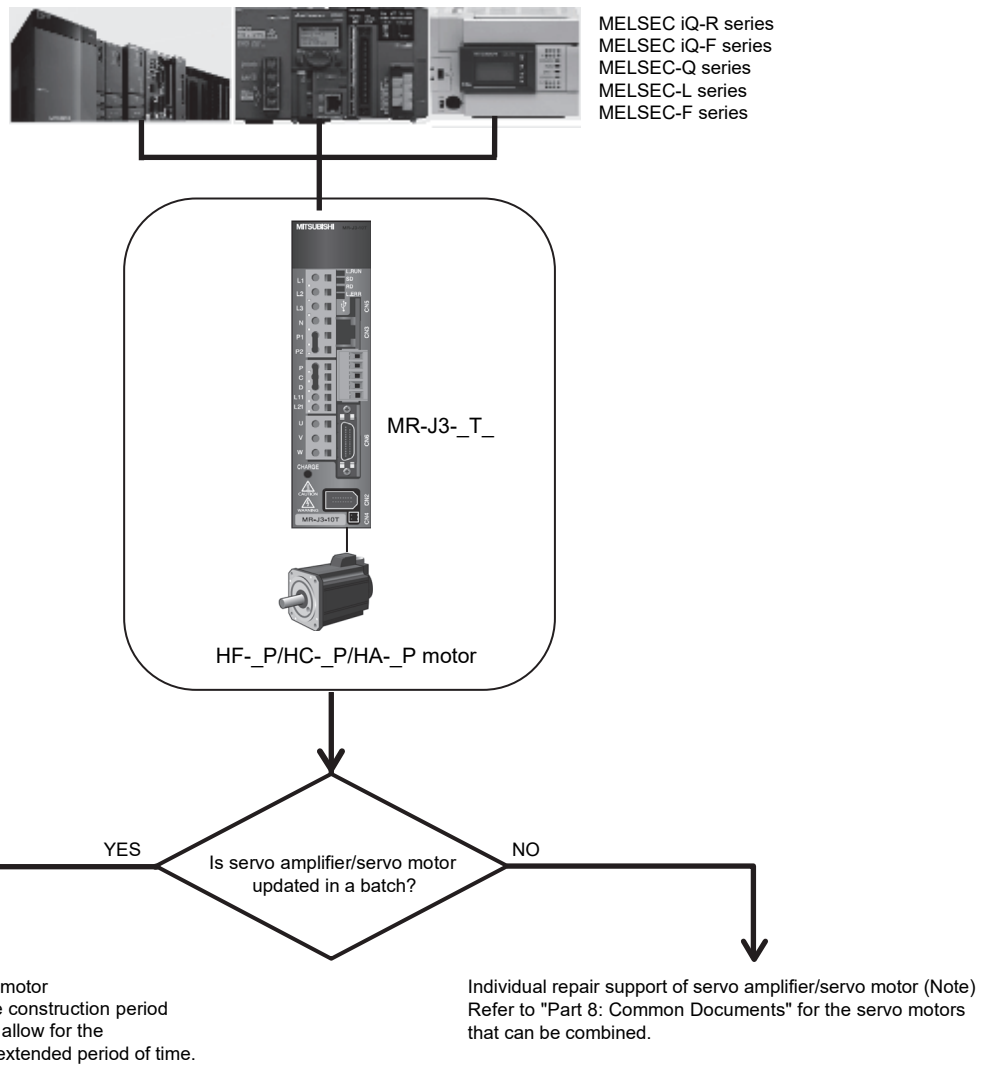

Note. Individual repair support indicates replacement repair.

Part 7: Review on Replacement of MR-J3-_T_ (CC-Link communication operation) with MR-J4-_GF_

2.2 Replacement method

(1) Batch update to the MR-J4-_GF_ + HG motor

The connector or cable needs to be changed. Parameter migration is supported by the parameter converter function of MR Configurator2. (Refer to "Part 8: Common Materials".)

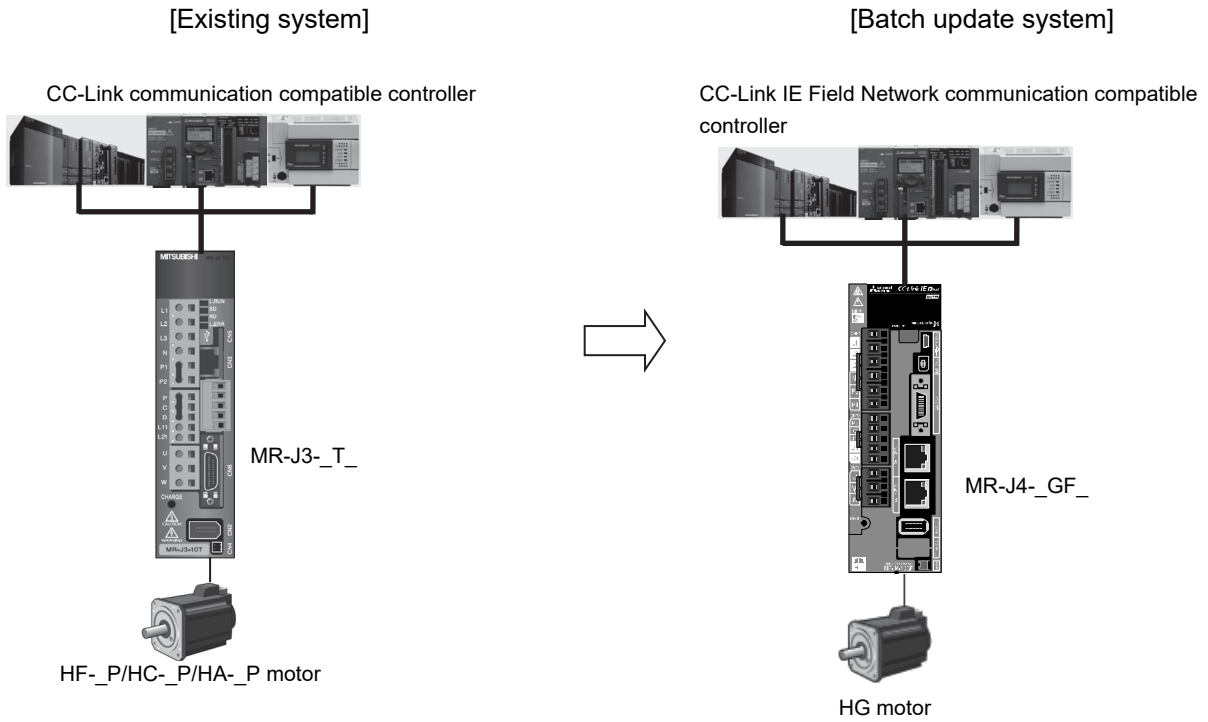

Part 7: Review on Replacement of MR-J3-_T_ (CC-Link communication operation) with MR-J4-_GF_

(2) Individual repair support of servo amplifier/servo motor

POINT			
<ul style="list-style-type: none"> ● The HG motor cannot be operated on MR-J3-_T_ (CC-Link communication operation). If replacing the servo motor with the HG motor, batch update to the MR-J4-_GF_ + HG motor is required. ● If the existing system has one of the combinations shown in the table below, "Batch update to the MR-J4-_GF_ + HG motor" is recommended. When adopting the HG motor, the servo amplifier capacity needs to be changed. (Consider replacement after checking "Torque characteristics" in "Part 9: Review on Replacement of Motor".) ● For replacement from the "HC-LP motor", low inertia "HG-JR motor" is recommended. <p>When using a servo motor other than the one in the replacement example below, the motor inertia and other properties will be different. Therefore, consider whether it can be applied to the device before use.</p>			
Existing model		Batch update replacement model example	
Servo motor	Servo amplifier	Servo motor	Servo amplifier
HC-RP103(B)G5 1/_	MR-J3-200T	HG-SR102(B)G5 1/_	MR-J4-100GF
HC-RP203(B)G5 1/_	MR-J3-350T	HG-SR202(B)G5 1/_	MR-J4-200GF
HC-RP353(B)G5 1/_	MR-J3-500T	HG-SR352(B)G5 1/_	MR-J4-350GF
HC-RP103(B)G7 1/_	MR-J3-200T	HG-SR102(B)G7 1/_	MR-J4-100GF
HC-RP203(B)G7 1/_	MR-J3-350T	HG-SR202(B)G7 1/_	MR-J4-200GF
HC-RP353(B)G7 1/_	MR-J3-500T	HG-SR352(B)G7 1/_	MR-J4-350GF
HC-LP52(B)	MR-J3-60T	HG-JR73(B)	MR-J4-70GF
HC-LP102(B)	MR-J3-100T	HG-JR153(B)	MR-J4-200GF
HC-LP152(B)	MR-J3-200T	HG-JR353(B)	MR-J4-350GF

Part 7: Review on Replacement of MR-J3-_T_ (CC-Link communication operation) with MR-J4-_GF_

(a) When replacing the servo amplifier

The J3 series servo motor can be operated on the MR-J4-_GF_ servo amplifier. Refer to "Part 8: Common Documents" for the target servo motors.

CC-Link IE Field Network communication compatible controller

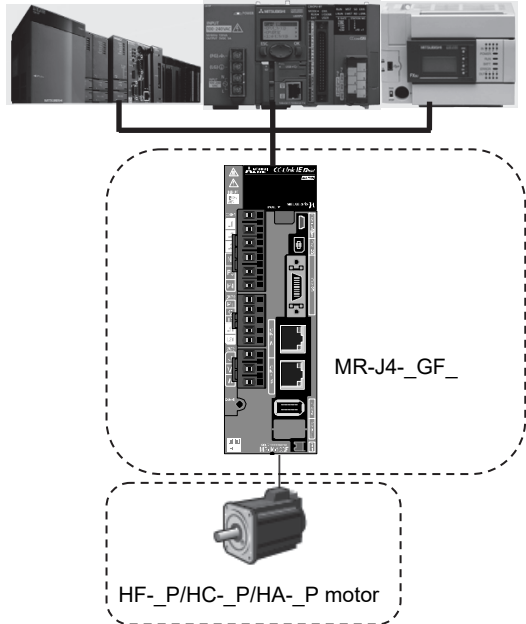

(b) When replacing the servo motor

The HG motor cannot be operated on the MR-J3-_T_ (CC-Link communication operation) servo amplifier. If replacing the servo motor with the HG motor, batch update to the MR-J4-_GF_ + HG motor is required.

Part 7: Review on Replacement of MR-J3-_T_ (CC-Link communication operation) with MR-J4-_GF_

3. DIFFERENCES BETWEEN THE MR-J3-_T_ (CC-Link COMMUNICATION OPERATION) AND MR-J4-_GF_

3.1 Function comparison table

POINT
<ul style="list-style-type: none"> ● Different functions are shaded. ● This table describes the case where [Pr. PN03 Communication mode setting for CC-Link IE communication] of MR-J4-_GF_ is set to "___ 1" and the station-specific mode is set to I/O mode.

(1) 200 V class

Item	MR-J3-_T_ (CC-Link communication operation)	MR-J4-_GF_
1	Capacity range	0.1 to 22 kW/200 V
2	Internal regenerative resistor	Built-in (0.2 to 7 kW) External (11 to 22 kW)
3	Dynamic brake	Built-in (0.1 to 7 kW) External (11 to 22 kW) The coasting distance may vary. (Note 1)
4	Control circuit power supply	1-phase 200 V AC to 230 V AC
5	Main circuit power supply	1-phase 200 V AC to 240 V AC (0.1 to 0.75 kW) 3-phase 200 V AC to 230 V AC (0.1 to 22 kW)
6	24 V DC power supply	External supply required
7	Auto tuning	Real-time auto tuning: 32 stages Advanced gain search
8	Control mode	Real-time auto tuning: 40 stages One-touch tuning
9	Positioning mode (point table method)	<ul style="list-style-type: none"> • Positioning mode (point table method) • Positioning mode (indexer method) • Speed control mode (point table method)
10	Positioning mode (indexer method)	<ul style="list-style-type: none"> • Positioning mode (point table method) • Positioning mode (indexer method) • Speed control mode (point table method)

Part 7: Review on Replacement of MR-J3-_T_ (CC-Link communication operation) with MR-J4-_GF_

Item		MR-J3-_T_ (CC-Link communication operation)	MR-J4-_GF_
11	Speed control mode (point table method)	Speed command input <ul style="list-style-type: none"> Speed command data (servo motor speed) is set by the remote register. Speed number input <ul style="list-style-type: none"> Servo motor speed and acceleration/deceleration time constants are selected in the point table. 	Speed command input <ul style="list-style-type: none"> Speed command data (servo motor speed) is set by the remote register. Speed number input <ul style="list-style-type: none"> Servo motor speed and acceleration/deceleration time constants are selected in the point table.
12	Pulse input	Manual pulse generator (dedicated for MR-HDP01 only) Open-collector Pulse resolution: 1000 pulses/rev Maximum speed: Instantaneous maximum 600 r/min Normal 200 r/min	Not supported
13	Encoder pulse output	A/B/Z-phase pulse (differential line driver)	A/B/Z-phase pulse (differential line driver) Z-phase pulse (open collector)
14	DIO interface	Input/output: Sink/Source	Input/output: Sink/Source
15	Analog input/output	Not supported	(Input) None (Output) 10 bits or its equivalent × 2ch
16	Parameter setting method	Setup software (SETUP221E) MR Configurator2 CC-Link communication compatible controller	MR Configurator2 CC-Link IE Field Network communication compatible controller
17	Setup software communication	USB	USB
18	Servo motor (encoder resolution)	HF-_P series (18-bit ABS) HA-_P series (18-bit ABS)	HG series (22 -bit ABS)
19	Motor maximum torque	HF-KP 350%	HG-KR 350%
		HF-MP 300%	HG-MR 300%
		HF-SP 300%	HG-SR 300%
		HF-JP 300%	HG-JR 300%
		HA-LP 250%	HG-JR 300%
20	LED display	7-segment 3-digit	7-segment 3-digit
21	Advanced vibration suppression control	Available	Available (Advanced vibration suppression control II)
22	Adaptive filter II	Available	Available
23	Notch filter	Available (2 pcs.)	Available (5 pcs.)
24	Tough drive	Not available	Available
25	Drive recorder	Not available	Available
26	Forced stop	EM1 (DB stop)	EM1 (DB stop)/EM2 (deceleration to stop) can be selected.

- Note
1. Refer to "Part 8: Common Documents 1.2.3 Dynamic characteristics" for the coasting distance.
 2. If using a 1-phase 200 V AC to 240 V AC power supply with a 1 kw/2 kW servo amplifier, operate the servo amplifier at 75% or less of the effective load ratio.

Part 7: Review on Replacement of MR-J3-_T_ (CC-Link communication operation) with MR-J4-_GF_

(2) 400 V class

Item		MR-J3-_T_ (CC-Link communication operation)	MR-J4-_GF_
1	Capacity range	0.6 to 22 kW/400 V	0.6 to 22 kW/400 V
2	Internal regenerative resistor	Built-in (0.6 to 7 kW) External (11 to 22 kW)	Built-in (0.6 to 7 kW) External (11 to 22 kW)
3	Dynamic brake	Built-in (0.6 to 7 kW) External (11 to 22 kW)	Built-in (0.6 to 7 kW) External (11 to 22 kW) The coasting distance may vary. (Note)
4	Control circuit power supply	1-phase 380 V AC to 480 V AC	1-phase 380 V AC to 480 V AC
5	Main circuit power supply	3-phase 380 V AC to 480 V AC	3-phase 380 V AC to 480 V AC
6	24 V DC power supply	External supply required	External supply required
7	Auto tuning	Real-time auto tuning: 32 stages Advanced gain search	Real-time auto tuning: 40 stages One-touch tuning
8	Control mode	<ul style="list-style-type: none"> ▪ Positioning mode (point table method) ▪ Positioning mode (indexer method) ▪ Speed control mode (point table method) 	<ul style="list-style-type: none"> ▪ Positioning mode (point table method) ▪ Positioning mode (indexer method) ▪ Speed control mode (point table method)
9	Positioning mode (point table method)	Automatic operation mode <ul style="list-style-type: none"> ▪ Automatic operation using the point table Manual operation mode <ul style="list-style-type: none"> ▪ JOG operation ▪ Manual pulse generator operation Homing mode <ul style="list-style-type: none"> ▪ Dog type ▪ Count type ▪ Data set type ▪ Stopper type ▪ Home position ignorance (servo-on position as home position) ▪ Dog type rear end reference ▪ Count type front end reference ▪ Dog cradle type ▪ Dog type last Z-phase reference ▪ Dog type front end reference ▪ Dogless Z-phase reference ▪ Automatic retract function used for the home position return ▪ Automatic positioning to home position function Roll feed mode using the roll feed display function	Automatic operation mode <ul style="list-style-type: none"> ▪ Automatic operation using the point table Manual operation mode <ul style="list-style-type: none"> ▪ JOG operation Homing mode <ul style="list-style-type: none"> ▪ Dog type ▪ Count type ▪ Data set type ▪ Stopper type ▪ Home position ignorance (servo-on position as home position) ▪ Dog type rear end reference ▪ Count type front end reference ▪ Dog cradle type ▪ Dog type last Z-phase reference ▪ Dog type front end reference ▪ Dogless Z-phase reference ▪ Automatic retract function used for the home position return ▪ Automatic positioning to home position function Roll feed mode using the roll feed display function
10	Positioning mode (indexer method)	Automatic operation mode <ul style="list-style-type: none"> ▪ Rotation direction specifying indexer ▪ Shortest rotating indexer Manual operation mode <ul style="list-style-type: none"> ▪ Indexer JOG operation ▪ JOG operation Homing mode <ul style="list-style-type: none"> ▪ Torque limit changing dog type ▪ Torque limit changing data set type ▪ Automatic retract function used for the home position return 	Automatic operation mode <ul style="list-style-type: none"> ▪ Rotation direction specifying indexer ▪ Shortest rotating indexer Manual operation mode <ul style="list-style-type: none"> ▪ JOG operation ▪ Station JOG operation Homing mode <ul style="list-style-type: none"> ▪ Torque limit changing dog type ▪ Torque limit changing data set type ▪ Automatic retract function used for the home position return
11	Speed control mode (point table method)	Speed command input <ul style="list-style-type: none"> ▪ Speed command data (servo motor speed) is set by the remote register. Speed number input <ul style="list-style-type: none"> ▪ Servo motor speed and acceleration/deceleration time constants are selected in the point table. 	Speed command input <ul style="list-style-type: none"> ▪ Speed command data (servo motor speed) is set by the remote register. Speed number input <ul style="list-style-type: none"> ▪ Servo motor speed and acceleration/deceleration time constants are selected in the point table.
12	Pulse input	Manual pulse generator (dedicated for MR-HDP01 only) Open-collector Pulse resolution: 1000 pulses/rev Maximum speed: Instantaneous maximum 600 r/min Normal 200 r/min	Not supported

Part 7: Review on Replacement of MR-J3-_T_ (CC-Link communication operation) with MR-J4-_GF_

Item		MR-J3-_T_ (CC-Link communication operation)	MR-J4-_GF_
13	Encoder pulse output	A/B/Z-phase pulse (differential line driver)	A/B/Z-phase pulse (differential line driver) Z-phase pulse (open collector)
14	DIO interface	Input/output: Sink/Source	Input/output: Sink/Source
15	Analog input/output	Not supported	(Input) None (Output) 10 bits or its equivalent × 2ch
16	Parameter setting method	Setup software (SETUP221E) MR Configurator2 CC-Link communication compatible controller	MR Configurator2 CC-Link IE Field Network communication compatible controller
17	Setup software communication	USB	USB
18	Servo motor (encoder resolution)	HF-_P series (18-bit ABS) HA-_P series (18-bit ABS)	HG series (22 -bit ABS)
19	Motor maximum torque	HF-SP 300%	HG-SR 300%
		HF-JP 300%	HG-JR 300%
		HA-LP 250%	HG-JR 300%
20	LED display	7-segment 3-digit	7-segment 3-digit
21	Advanced vibration suppression control	Available	Available (Advanced vibration suppression control II)
22	Adaptive filter II	Available	Available
23	Notch filter	Available (2 pcs.)	Available (5 pcs.)
24	Tough drive	Not available	Available
25	Drive recorder	Not available	Available
26	Forced stop	EM1 (DB stop)	EM1 (DB stop)/EM2 (deceleration to stop) can be selected.

Note. Refer to "Part 8: Common Documents 1.2.3 Dynamic characteristics" for the coasting distance.

Part 7: Review on Replacement of MR-J3-_T_ (CC-Link communication operation) with MR-J4-_GF_

(3) 100 V class

Item		MR-J3-_T_ (CC-Link communication operation)	MR-J4-_GF_
1	Capacity range	0.1 to 0.4 kW/100 V	0.1 to 0.4 kW/100 V
2	Internal regenerative resistor	None (0.1 kW) Built-in (0.2, 0.4 kW)	None (0.1 kW) Built-in (0.2, 0.4 kW)
3	Dynamic brake	Built-in (0.1 to 0.4 kW)	Built-in (0.1 to 0.4 kW) The coasting distance may vary. (Note)
4	Control circuit power supply	1-phase 100 V AC to 120 V AC	1-phase 100 V AC to 120 V AC
5	Main circuit power supply	1-phase 100 V AC to 120 V AC (0.1 to 0.4 kW)	1-phase 100 V AC to 120 V AC (0.1 to 0.4 kW)
6	24 V DC power supply	External supply required	External supply required
7	Auto tuning	Real-time auto tuning: 32 stages Advanced gain search	Real-time auto tuning: 40 stages One-touch tuning
8	Control mode	<ul style="list-style-type: none"> ▪ Positioning mode (point table method) ▪ Positioning mode (indexer method) ▪ Speed control mode (point table method) 	<ul style="list-style-type: none"> ▪ Positioning mode (point table method) ▪ Positioning mode (indexer method) ▪ Speed control mode (point table method)
9	Point table method operation mode	Automatic operation mode <ul style="list-style-type: none"> ▪ Automatic operation using the point table Manual operation mode <ul style="list-style-type: none"> ▪ OG operation ▪ Manual pulse generator operation Homing mode <ul style="list-style-type: none"> ▪ Dog type ▪ Count type ▪ Data set type ▪ Stopper type ▪ Home position ignorance (servo-on position as home position) ▪ Dog type rear end reference ▪ Count type front end reference ▪ Dog cradle type ▪ Dog type last Z-phase reference ▪ Dog type front end reference ▪ Dogless Z-phase reference ▪ Automatic retract function used for the home position return ▪ Automatic positioning to home position function Roll feed mode using the roll feed display function	Automatic operation mode <ul style="list-style-type: none"> ▪ Automatic operation using the point table Manual operation mode <ul style="list-style-type: none"> ▪ JOG operation Homing mode <ul style="list-style-type: none"> ▪ Dog type ▪ Count type ▪ Data set type ▪ Stopper type ▪ Home position ignorance (servo-on position as home position) ▪ Dog type rear end reference ▪ Count type front end reference ▪ Dog cradle type ▪ Dog type last Z-phase reference ▪ Dog type front end reference ▪ Dogless Z-phase reference ▪ Automatic retract function used for the home position return ▪ Automatic positioning to home position function Roll feed mode using the roll feed display function
10	Positioning mode (indexer method)	Automatic operation mode <ul style="list-style-type: none"> ▪ Rotation direction specifying indexer ▪ Shortest rotating indexer Manual operation mode <ul style="list-style-type: none"> ▪ Indexer JOG operation ▪ JOG operation Homing mode <ul style="list-style-type: none"> ▪ Torque limit changing dog type ▪ Torque limit changing data set type ▪ Automatic retract function used for the home position return 	Automatic operation mode <ul style="list-style-type: none"> ▪ Rotation direction specifying indexer ▪ Shortest rotating indexer Manual operation mode <ul style="list-style-type: none"> ▪ JOG operation ▪ Station JOG operation Homing mode <ul style="list-style-type: none"> ▪ Torque limit changing dog type ▪ Torque limit changing data set type ▪ Automatic retract function used for the home position return
11	Speed control mode (point table method)	Speed command input <ul style="list-style-type: none"> ▪ Speed command data (servo motor speed) is set by the remote register. Speed number input <ul style="list-style-type: none"> ▪ Servo motor speed and acceleration/deceleration time constants are selected in the point table. 	Speed command input <ul style="list-style-type: none"> ▪ Speed command data (servo motor speed) is set by the remote register. Speed number input <ul style="list-style-type: none"> ▪ Servo motor speed and acceleration/deceleration time constants are selected in the point table.
12	Pulse input	Manual pulse generator (dedicated for MR-HDP01 only) Open-collector Pulse resolution: 1000 pulses/rev Maximum speed: Instantaneous maximum 600 r/min Normal 200 r/min	Not supported
13	Encoder pulse output	A/B/Z-phase pulse (differential line driver)	A/B/Z-phase pulse (differential line driver) Z-phase pulse (open collector)

Part 7: Review on Replacement of MR-J3-_T_ (CC-Link communication operation) with MR-J4-_GF_

	Item	MR-J3-_T_ (CC-Link communication operation)	MR-J4-_GF_
14	DIO interface	Input/output: Sink/Source	Input/output: Sink/Source
15	Analog input/output	Not supported	(Input) None (Output) 10 bits or its equivalent × 2ch
16	Parameter setting method	Setup software (SETUP221E) MR Configurator2 CC-Link communication compatible controller	MR Configurator2 CC-Link IE Field Network communication compatible controller
17	Setup software communication	USB	USB
18	Servo motor (encoder resolution)	HF-_P series (18-bit ABS) HA-_P series (18-bit ABS)	HG series (22 -bit ABS)
19	Motor maximum torque	HF-KP 350% HF-MP 300%	HG-KR 350% HG-MR 300%
20	LED display	7-segment 3-digit	7-segment 3-digit
21	Advanced vibration suppression control	Available	Available (Advanced vibration suppression control II)
22	Adaptive filter II	Available	Available
23	Notch filter	Available (2 pcs.)	Available (5 pcs.)
24	Tough drive	Not available	Available
25	Drive recorder	Not available	Available
26	Forced stop	EM1 (DB stop)	EM1 (DB stop)/EM2 (deceleration to stop) can be selected.

Note. Refer to "Part 8: Common Documents 1.2.3 Dynamic characteristics" for the coasting distance.

Part 7: Review on Replacement of MR-J3-_T_ (CC-Link communication operation) with MR-J4-_GF_

3.1.1 CC-Link => CC-Link IE Field Network communication operation specifications list

Item		Description			
Servo amplifier model		MR-J3-_T_ (CC-Link communication operation)	MR-J4-_GF_		
Command method	Operation specifications		Positioning by specifying the point table number (255 points)		
	Point table	Position command input	<p>Setting in the point table</p> <p>Setting range of feed length for one point: -999999 to 999999 [$\times 10^{\text{STM}} \mu\text{m}$]</p> <p>* STM setting value: 0 to 3</p>	<p>Setting in the point table</p> <p>Setting range of feed length for one point: -999999 to 999999 [$\times 10^{\text{STM}} \mu\text{m}$], -99.9999 to 99.9999 [$\times 10^{\text{STM}} \text{inch}$], -999999 to 999999 [pulse]</p> <p>Rotation angle setting range: -360.000 to 360.000 [degree]</p> <p>* STM setting value: 0 to 3</p>	
		Incremental value command method	<p>Setting in the point table</p> <p>Setting range of feed length for one point: 0 to 999999 [$\times 10^{\text{STM}} \mu\text{m}$]</p> <p>* STM setting value: 0 to 3</p>	<p>Setting in the point table</p> <p>Setting range of feed length for one point: 0 to 999999 [$\times 10^{\text{STM}} \mu\text{m}$], 0 to 99.9999 [$\times 10^{\text{STM}} \text{inch}$], 0 to 999999 [pulse]</p> <p>Rotation angle setting range: 0 to 999.999 [degree]</p> <p>* STM setting value: 0 to 3</p>	
	Speed command input		<p>Set the acceleration/deceleration time constants in the point table.</p> <p>Set the S-pattern acceleration/deceleration time constant in [Pr. PC13].</p>	<p>Set the acceleration/deceleration time constants in the point table.</p> <p>Set the S-pattern acceleration/deceleration time constant in [Pr. PT51].</p>	
	System		Signed absolute value command method/incremental value command method		
	Torque limit		Depends on the parameter setting or link device.		
	Position command data input	Operation specifications		Positioning by setting the remote register	
		Position command input	Absolute value command method	<p>Setting of position command data by the remote register</p> <p>Feed length input setting range: -999999 to 999999 [$\times 10^{\text{STM}} \mu\text{m}$]</p> <p>* STM setting value: 0 to 3</p>	<p>Setting of position command data by the remote register</p> <p>Feed length input setting range: -999999 to 999999 [$\times 10^{\text{STM}} \mu\text{m}$], -99.9999 to 99.9999 [$\times 10^{\text{STM}} \text{inch}$], -999999 to 999999 [pulse]</p> <p>Rotation angle setting range: -360.000 to 360.000 [degree]</p> <p>* STM setting value: 0 to 3</p>
			Incremental value command method	<p>Setting in the point table</p> <p>Setting range of feed length for one point: 0 to 999999 [$\times 10^{\text{STM}} \mu\text{m}$]</p> <p>* STM setting value: 0 to 3</p>	<p>Setting of position command data by the remote register</p> <p>Feed length input setting range: 0 to 999999 [$\times 10^{\text{STM}} \mu\text{m}$], 0 to 99.9999 [$\times 10^{\text{STM}} \text{inch}$], 0 to 999999 [pulse]</p> <p>Rotation angle setting range: 0 to 999.999 [degree]</p> <p>* STM setting value: 0 to 3</p>
		Speed command input		<p>Selected from the point table by the remote register.</p> <p>Speed command data (speed) is set by the remote register.</p> <p>Set the S-pattern acceleration/deceleration time constant in [Pr. PC13].</p>	<p>Selected from the point table by the remote register.</p> <p>Speed command data (speed) is set by the remote register.</p> <p>Set the S-pattern acceleration/deceleration time constant in [Pr. PT51].</p>
System		Signed absolute position command method, incremental value command method			
Torque limit		Depends on the parameter setting or link device.			
Indexer	Operation specifications		Positioning by specifying the station position, maximum number of divisions: 255 divisions		
	Speed command input		<p><Remote register></p> <p>Speed command data (speed) is set by the remote register.</p> <p><Speed number input></p> <p>Speed and acceleration/deceleration time constants are selected in the point table.</p>	<p>Selected from the point table by the remote register.</p> <p>Speed command data (speed and acceleration/deceleration time constant) is set by the remote register.</p>	
	System		Rotation direction specifying indexer/shortest rotating indexer		
	Torque limit		Setting by the parameter setting or link device		
Speed control	Command method	Remote register	Speed command data (speed) is set by the remote register.	Speed command data (speed) is set by the remote register.	
		Speed number input	<p>Speed and acceleration/deceleration time constants are selected in the point table.</p> <p>Speed command: 8 speed, acceleration/deceleration time constant: 2</p>	<p>Speed and acceleration/deceleration time constants are selected in the point table.</p> <p>Speed command: 255 speed, acceleration/deceleration time constant: 2</p>	
	Speed command data setting range		<p>When set in units of 1 [r/min]: 0 to servo motor permissible speed [r/min]</p> <p>When set in units of 0.1 [r/min]: 0 to servo motor permissible speed, or 0 to 6553.5 [r/min]</p>	Set in units of 0.01 [r/min]: 0 to servo motor permissible speed [r/min]	

Part 7: Review on Replacement of MR-J3-_T_ (CC-Link communication operation) with MR-J4-_GF_

Item		Description		
Servo amplifier model		MR-J3-_T_ (CC-Link communication operation)	MR-J4-_GF_	
Operation mode	Automatic operation mode	Point table	One positioning operation Point table No. input method/position data input method Perform one positioning operation based on the position command and speed command.	
			Automatic continuous positioning operation Varying-speed operation (2 speed to 255 speed)/automatic continuous positioning operation (2 points to 255 points)/automatic continuous operation to the point table selected at startup/automatic continuous operation to point table No. 1	
		Indexer	Rotation direction specifying indexer Perform positioning to the set station. Rotation direction can be specified.	
			Shortest rotating indexer Perform positioning to the set station. Rotate in the direction closer to the current position.	
		Manual operation mode	Point table	JOG operation Inching operation is performed based on the speed data set in the parameters.
				Manual pulse generator operation Manual feed is performed by a manual pulse generator. Command pulse multiplying factor: Select ×1, ×10, or ×100 with parameters.
	Indexer	JOG operation Inching operation is performed based on the speed data set in the parameters. Decelerates and stops regardless of the station when stopped.		
		Station JOG operation When the start signal is turned on, it rotates in the rotation direction specified in the rotation direction decision. When the start signal is turned off, positioning is performed to the nearest station to which deceleration stop is possible.		
	Homing mode	Point table	Dog type Performs homing using the Z-phase pulse after a moving part has moved past the proximity dog. Home position address settable/home position shift amount settable/home position return direction selectable Automatic retract on dog back to home position/automatic stroke retract function	
			Count type Performs homing using the encoder pulse count after a moving part came into contact with the proximity dog. Home position address settable/home position shift amount settable/home position return direction selectable/automatic retract on dog back to home position/automatic stroke retract function	
			Data set type Performs homing without a dog. Any position settable as home position by manual operation or other methods/home position address settable	
			Stopper type Performs homing with a workpiece pressed against the stroke end. Home position return direction selectable/home position address settable	
			Home position ignorance (servo-on position as home position) The home position is the position where SON (Servo-on) is turned on. Home position address settable	
			Dog type rear end reference Performs homing with reference to the rear end of the proximity dog. Home position return direction selectable/home position shift amount settable/home position address settable/automatic retract on dog back to home position/automatic stroke retract function	
Count type front end reference Performs homing with reference to the front end of the proximity dog. Home position return direction selectable/home position shift amount settable/home position address settable/automatic retract on dog back to home position/automatic stroke retract function				
Dog cradle type Performs homing using the first Z-phase pulse with reference to the front end of the proximity dog. Home position return direction selectable/home position shift amount settable/home position address settable/automatic retract on dog back to home position/automatic stroke retract function				
Dog type last Z-phase reference Performs homing using the last Z-phase pulse with reference to the front end of the proximity dog. Home position return direction selectable/home position shift amount settable/home position address settable/automatic retract on dog back to home position/automatic stroke retract function				
Dog type front end reference Performs homing with reference to the front end of the proximity dog in the direction of the front end. Home position return direction selectable/home position shift amount settable/home position address settable/automatic retract on dog back to home position/automatic stroke retract function				
Dogless Z-phase reference Performs homing with reference to the first Z-phase in the direction of that Z-phase. Home position return direction selectable/home position shift amount settable/home position address settable				
Indexer			Torque limit changing dog type Performs homing using the Z-phase pulse count after a moving part has moved past the proximity dog. Home position return direction selectable/home position shift amount settable/home position address settable Automatic retract on dog back to home position/automatic stroke retract position/torque limit automatic switching function	Performs homing using the Z-phase pulse count after a moving part came into contact with the proximity dog. Home position return direction selectable/home position shift amount settable/home position address settable Torque limit automatic switching function By default, the automatic retract function used for the home position return is disabled. To enable the automatic retract function used for the home position return, set [Pr. PT70] to "___ 3".
			Torque limit changing data set type Performs homing without a dog. Any position settable as home position, home position address settable, torque limit automatic switching function	
Automatic positioning to home position function		High-speed automatic positioning to a defined home position		
Other features		Absolute position detection/backlash compensation/overtravel prevention with external limit switch/software stroke limit/override with analog input		

Part 7: Review on Replacement of MR-J3-_T_ (CC-Link communication operation) with MR-J4-_GF_

3.1.2 Function list

The function list of the MR-J3-_T_ (CC-Link communication operation) and MR-J4-_GF_ servo amplifier is shown in the following table. Refer to each servo amplifier instruction manual for details of each function.

Point
<ul style="list-style-type: none"> ● Different functions are shaded. ● The symbols in the control mode column indicate the following control modes. CP: Positioning mode (point table method) PS: Positioning mode (indexer method) SP: Speed control mode (point table method)

Function	MR-J3-_T_ (CC-Link communication operation)	MR-J4-_GF_	Control mode		
			CP	PS	SP
Positioning by automatic operation	This function operates the servo motor according to the setting values by selecting the point table with preset 255 points. The position command and speed command can also be set using the remote register.		○	○	○
	The operation is performed to the next station divided into any number from 2 to 255 in advance. The position command and speed command can also be set using the remote register.		○	○	○
Speed change operation	The operation is performed at the speed set in the next point table during positioning. (Maximum setting speed: 255)		○	○	○
Automatic continuous positioning operation	Select one point table and start it up to continuously operate the point table with consecutive numbers.		○	○	○
Homing	Dog type/count type/data set type/topper type/home position ignorance/dog type rear end reference/count type front end reference/dog cradle type/dog type last Z-phase reference/dog type front end reference/dogless Z-phase reference		○	○	○
	Torque limit changing dog type/torque limit changing data set type		○	○	○
High-resolution encoder	A 262144 pulses/rev high-resolution encoder is used for the servo motor detector.	A 4194304 pulses/rev high-resolution encoder is used for the encoder of the rotary servo motor compatible with the MELSERVO-J4 series.	○	○	○
Absolute position detection system	This function performs homing once, and thereafter does not require homing at every power-on.		○	○	○
Gain switching function	This function switches gains during rotation and during stop, and uses an input device to switch gains during operation.		○	○	○
Advanced vibration suppression control	<Advanced vibration suppression control> This function suppresses vibration and residual vibration at an arm end.	<Advanced vibration suppression control II> This function suppresses vibration and residual vibration at an arm end.	○	○	○
Adaptive filter II	This is a function in which the servo amplifier detects machine resonance and sets the filter characteristics automatically to suppress mechanical system vibration.		○	○	○
Low-pass filter	This function is effective in suppressing resonance of a high frequency generated as the response level of the servo system is increased.		○	○	○
Machine analyzer function	This function analyzes the frequency characteristics of the mechanical system by simply connecting the servo amplifier with a Setup software (SETUP221E) installed personal computer. Setup software (SETUP221E) is required for this function.	This function analyzes the frequency characteristics of the mechanical system by simply connecting the servo amplifier with an MR Configurator2 installed personal computer. MR Configurator2 is required for this function.	○	○	○
Robust disturbance compensation	<Robust disturbance compensation> This function improves a disturbance response when a response performance cannot be increased because of a large load to motor inertia ratio, such as a roll feed axis. Setup software (SETUP221E) is required for this function.	<Robust filter> This function improves a disturbance response when a response performance cannot be increased because of a large load to motor inertia ratio, such as a roll feed axis.	○	○	○
Slight vibration suppression control	This function suppresses vibration of ±1 pulse generated at each servo motor stop. [Pr. PB24]		○	○	○

Part 7: Review on Replacement of MR-J3-_T_ (CC-Link communication operation) with MR-J4-_GF_

Function	MR-J3-_T_ (CC-Link communication operation)	MR-J4-_GF_	Control mode		
			CP	PS	SP
Electronic gear	An electronic gear is used to adjust the servo amplifier setting values so that they match the travel distance of the machine. Also, by changing the electronic gear, the machine can be moved at any magnification with respect to the travel distance by the servo amplifier. [Pr. PA06]/ [Pr. PA07]	The position command can be multiplied by 1/864 to 271470. [Pr. PA06]/ [Pr. PA07]	○	○	○
		The position command can be multiplied by 1/9999 to 9999. [Pr. PA06]/ [Pr. PA07]	○	○	○
Auto tuning	This function automatically adjusts the gain to an optimum value even if the load applied to the servo motor shaft varies.		○	○	○
S-pattern acceleration/deceleration time constants	This function enables smooth acceleration/deceleration. [Pr. PC13]	This function enables smooth acceleration/deceleration. [Pr. PT51]	○	○	○
Regenerative option	Use this function if the built-in regenerative resistor of the servo amplifier does not have sufficient regenerative capacity for the generated regenerative power.		○	○	○
Brake unit	Use this function if the regenerative option does not have sufficient regenerative capacity. This function is available on servo amplifiers with a capacity of 5 kW or more.		○	○	○
Power regeneration converter	Use this function if the regenerative option does not have sufficient regenerative capacity. This function is available on servo amplifiers with a capacity of 5 kW or more.		○	○	○
Alarm history clear	This function clears alarm histories. [Pr. PC18]	This function clears alarm histories. [Pr. PC21]	○	○	○
Input signal selection (device setting)	This function assigns input devices such as Servo-on (SON) to certain pins of the CN6 connector in positioning mode (point table method). [Pr. PD06] to [Pr. PD08] This function is disabled in positioning mode (indexer method) and speed control mode (point table method).	This function assigns input devices such as PC (Proportional control (PID control)) to certain pins of the CN3 connector. [Pr. PD03] to [Pr. PD05]	○	○	○
Output signal selection (device setting)	This function assigns output devices such as Malfunction (ALM)/Dynamic brake interlock (DB) to certain pins of the CN6 connector in positioning mode (point table method). [Pr. PD09] to [Pr. PD11] This function is disabled in positioning mode (indexer method) and speed control mode (point table method).	This function assigns output devices such as MBR (Electromagnetic brake interlock) to certain pins of the CN3 connector. [Pr. PD07] to [Pr. PD09]	○	○	○
Torque limit	This function limits the servo motor torque. [Pr. PA11]/[Pr. PA12]		○	○	○
Output signal (DO) forced output	This function forcibly switches the output signals on and off regardless of the servo status. Use this function for purposes such as checking output signal wiring.		○	○	○
Test operation mode	JOG operation/positioning operation/motor-less operation/DO forced output/program operation/single-step feed However, a parameter unit or Setup software (SETUP221E) is required.	JOG operation/positioning operation/motor-less operation/DO forced output/program operation/single-step feed However, MR Configurator2 is required for positioning operation, program operation, and single-step feed.	○	○	○
Limit switch	External limit switches can be used to limit travel intervals of the servo motor.		○	○	○
Software limit	This function uses parameters to limit the travel intervals by address. Set the same function as the limit switch with parameters.		○	○	○
Serial communication	Use the RS-422 serial communication function for operations such as operating servos, changing parameters, and using the monitoring function.	The MR-J4-_GF_ is not supported.	○	○	○

Part 7: Review on Replacement of MR-J3-_T_ (CC-Link communication operation) with MR-J4-_GF_

3.1.3 Detailed comparison of functions

POINT
<ul style="list-style-type: none"> ● Refer to each servo amplifier instruction manual for details. ● Refer to "3.6 Comparison of parameter details" for details on the parameters.

(1) CC-Link function

Item	Difference in functions		Handling methods on MR-J4-_GF_	
	MR-J3-_T_	MR-J4-_GF_		
1	Occupied station number setting	Supported (one station occupied/two station occupied)	Not supported	
2	Number of remote input/output (RYn/RXn) link points	<When occupying one station> RYn/RXn: 32 points each <When occupying two stations> RYn/RXn: 64 points each	RYn/RXn: 64 points each	The number of link points is as shown on the left. The profile of the link device sent/received by cyclic communication with the master station is also different.
3	Number of remote register (RWwn/RWrn) link points	<When occupying one station> RWwn/RWrn: 4 points each <When occupying two stations> RWwn/RWrn: 8 points each	RWwn/RWrn: 16 points each	
4	Point table No. selection 1 to 8/next station selection 1 to 8	<When occupying one station> RYnA to RYnE <When occupying two stations> RYnA to RYnE RY (n + 2) 3 to RY (n + 2) 5	Not supported	
5	Speed selection 1 to 3	<When occupying two stations> RY (n + 2) C to RX (n + 2) E	Not supported	RWwnA: Set it with the lower 16 bits of speed command data/point table number.
6	Point table No. output 1 to 8/station output 1 to 8	<When occupying two stations> RX (n + 2) 2 to RX (n + 2) 9	Not supported	RWwn6: Read it from Point table No. output.
7	Forward rotation stroke end (RYn4)	This function can be used by selecting "Used in CC-Link" in [Pr. PD12].	Use the upper stroke limit (RY (n + 1) 0) and the lower stroke limit (RY (n + 1) 1).	Same as the specifications on the left.
8	Reverse rotation stroke end (RYn5)	It is enabled for the rotation direction of the servo motor.	This function can be used by selecting "Input from controller" in [Pr. PD41]. It is enabled for the address increasing/decreasing direction.	
9	Remote register (RWwn)	RWwn: Monitor 1	RWwn0: Monitor 1	
		RWwn+1: Monitor 2	RWwn+2: Monitor 2	
		RWwn+2: Instruction code	RWwn+4: Instruction code - Lower 16 bits RWwn+5: Instruction code - Upper 16 bits	
		RWwn+3: Write data	RWwn+C: Writing data - Lower 16 bits RWwn+D: Writing data - Upper 16 bits	
		<When occupying two stations> RWwn+4: Position command data - Lower 16 bits/point table No./next station RWwn+5: Position command data - Upper 16 bits	RWwn+8: Position command data - Lower 16 bits/point table No./next station No. RWwn+9: Position command data - Upper 16 bits	
		<When occupying two stations> RWwn+6: Speed command data/point table No.	RWwn+A: Speed command data - Lower 16 bits/point table No. RWwn+B: Speed command data - Upper 16 bits	

Part 7: Review on Replacement of MR-J3-_T_ (CC-Link communication operation) with MR-J4-_GF_

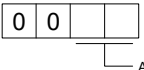
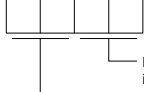
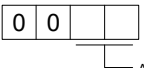
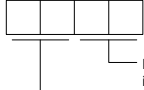
Item			Difference in specifications		Handling methods on MR-J4-_GF_	
			MR-J3-_T_	MR-J4-_GF_		
10	Remote register (RWrn)		<When occupying one station> RWrn: Monitor 1 data <When occupying two stations> RWrn: Monitor 1 data - Lower 16 bits RWrn+1: Monitor 1 data - Upper 16 bits	RWrn0: Monitor 1 data - Lower 16 bits RWrn+1: Monitor 1 data - Upper 16 bits	Same as the specifications on the left.	
			<When occupying one station> RWrn+1: Monitor 2 data <When occupying two stations> RWrn+5: Monitor 2 data - Lower 16 bits RWrn+6: Monitor 2 data - Upper 16 bits	RWrn+2: Monitor 2 data - Lower 16 bits RWrn+3: Monitor 2 data - Upper 16 bits		
			RWrn+2: Respond code	RWrn+4: Respond code		
			RWrn+3: Reading data	RWrn+C: Reading data - Lower 16 bits RWrn+D: Reading data - Upper 16 bits		
11	Monitor codes	0016h: Motor speed	Returns in units of 0.1 [r/min].	Returns in units of 0.01 [r/min].		
12	Monitor codes	001Bh: ABS position	Returns the upper 16-bit data.	Returns the upper 32-bit data.		
13	Reading instruction codes	0010h: Current alarm (warning) read	 Alarm No./Warning No.	 Details of the alarm or warning that is occurring The alarm number that is occurring or warning number		
14	Reading instruction codes	0020h to 0025h: Alarm No. in alarm history	 Alarm No. that occurred in the past	 Details of alarms that have occurred in the past Alarm number that occurred in the past		
15	Reading instruction codes	Device status (off/on) read	Input device status 0: 0040h	bit4: LSP	Check with bit 0 of 0041h.	The MR-J4-_GF_ is not supported.
				bit5: LSN	Check with bit 1 of 0041h.	
			Input device status 1: 0041h	bitA to bitE: DI0 to DI4	Not supported	Same as the specifications on the left.
				bit0: PSR	Check with bit 0 of 0042h.	
				bit1: SPR	Check with bit 1 of 0042h.	
				bit3 to bit5: DI5 to DI7	Not supported	
				bit6: TL1	Check with bit 6 of 0042h.	
				bit7: PC	Check with bit 7 of 0042h.	
				bit8: CDP	Check with bit 8 of 0042h.	
			bitA: CSL	Check with bit A of 0042h.	The MR-J4-_GF_ is not supported.	
bitB: INC	Check with bit B of 0042h.					
Input device status 2: 0042h	bitC to bitE: SP0 to SP2	Not supported	Check with bit A of 0043h.	Same as the specifications on the left.		
0050h: Output device status 0 0051h: Output device status 1 0052h: Output device status 2		Not supported		Check the status of the output device with the link device (RXn).		

Part 7: Review on Replacement of MR-J3-_T_ (CC-Link communication operation) with MR-J4-_GF_

(2) Operation

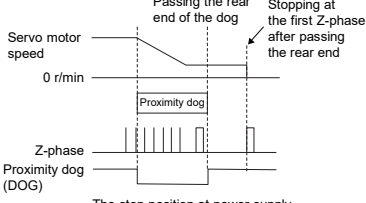
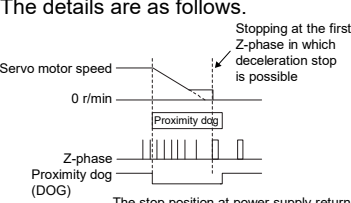
Item		Difference in specifications		Handling methods on MR-J4-_GF_
		MR-J3-_T_	MR-J4-_GF_	
1	Roll feed display function	Supported	Supported	Set [Pr. PT26] as required.
2	Speed control operation	Supported	Supported	Set [Pr. PA01] and [Pr. PN03] as required.
3	Automatic retract function used for the home position return	Supported	Supported	By default, the automatic retract function used for the home position return is disabled. To enable it, set [Pr. PT70] to "___3".
	Proximity dog input polarity	By default, dogs are detected with Proximity dog (DOG) turned off. The input polarity can be changed with [Pr. PD16].	By default, dogs are detected with Proximity dog (DOG) turned on. The input polarity can be changed with [Pr. PT29].	In the initial parameter values, the proximity dog input polarity is different between MR-J3-_T_ and MR-J4-_GF_. Review [Pr. PT29] as required.
	Torque limit changing dog type homing Stop position at home position return completion	<p>The stop position at home position return completion is the Z-phase after a moving part has moved past the dog.</p> <p>The details are as follows.</p>  <p>The stop position at power supply return completion is not on the dog.</p> <p>Deceleration starts from the front end of the proximity dog. After the rear end is passed, the position specified by the first Z-phase signal or the position of the first Z-phase signal shifted by the amount of home position shift distance is used as the home position.</p>	<p>When "___0" (initial value) is set in [Pr. PT70], the stop position at home position return completion is the Z-phase after a moving part has moved past the front end of the dog.</p> <p>The details are as follows.</p>  <p>The stop position at power supply return completion is not on the dog.</p> <p>Note: The proximity dog input polarity has changed in [Pr. PT29].</p> <p>Deceleration starts from the front end of the proximity dog. The position specified by the first Z-phase signal to which deceleration stop is possible or the position of the first Z-phase signal shifted by the home position shift distance is used as the home position.</p> <p>When "___3" is set in [Pr. PT70], the position specified by the first Z-phase signal after the rear end of the proximity dog is passed or the position of the first Z-phase signal shifted by the amount of home position shift distance is used as the home position. (Same as MR-J3-_T_)</p>	In the initial parameter values, the stop position at home position return completion is different between MR-J3-_T_ and MR-J4-_GF_. Review [Pr. PT70] as required.
4	Servo motor speed	The speed command unit can be selected from 1 [r/min] and 0.1 [r/min].	The speed command unit is 0.01 [r/min] only.	0.01 The unit is fixed to [r/min].
5	Torque limit value when indexer operation is stopped	[Pr. PC77] is compared with [Pr. PA11] and [Pr. PA12], and the smallest value is enabled.	<p>If "___0" (initial value) is set in [Pr. PT48], [Pr. PC77] is enabled.</p> <p>When "___1" is set in [Pr. PT48], [Pr. PC77] is compared with [Pr. PA11] and [Pr. PA12], and the smaller value is enabled. (Same as MR-J3-_T_)</p>	In the initial parameter values, the torque limit value when indexer operation is stopped is different between MR-J3-_T_ and MR-J4-_GF_. Review [Pr. PT48] as required.

Part 7: Review on Replacement of MR-J3-_T_ (CC-Link communication operation) with MR-J4-_GF_

(3) Input/output device

Item		Difference in specifications		Handling methods on MR-J4-_GF_	
		MR-J3-_T_	MR-J4-_GF_		
1	Reset (RES)	<Alarm release> Turn on Reset (RES) to release the current alarm.	Supported	Supported	The MR-J4-_GF_ is not supported.
		<Base circuit shut-off> Base circuit status selection for Reset (RES) on with the setting of [Pr. PD20]	Supported	Not supported	
2	Clear (CR)	Supported	Supported	Review [Pr. PD42] as required.	
3	Manual pulse generator (PP/NP)	Supported	Not supported	The MR-J4-_GF_ is not supported.	
	Manual pulse generator multiplication 1 (TP0)	Supported	Not supported		
	Manual pulse generator multiplication 2 (TP1)	Supported	Not supported		
4	Temporary stop/restart (TSTP)	Temporary stop/restart (TSTP) input is disabled if input during homing or JOG operation.	Temporary stop/restart (TSTP) input is enabled if input even during homing or JOG operation.		
5	Travel completion (MEND)	During indexer operation, travel completion (MEND) is turned off at servo-off.	During indexer operation, travel completion (MEND) remains on even at servo-off.		
6	Home position return completion (ZP)	Home position return completion (ZP)	Home position return completion 2 (ZP2)	Use Home position return completion 2 (ZP2).	
7	Output of home position return completion	Home position return completion (ZP) is turned off at servo-off.	Home position return completion 2 (ZP2) remains on even at servo-off.		
8	Forward rotation stroke end (LSP)	It can be used by setting "Used in CN6 external input signal" in [Pr. PD12] and assigning it to any input pin in [Pr. PD06] to [Pr. PD08].	It can be used by setting "Input from servo amplifier" in [Pr. PD41] and assigning it to any input pin in [Pr. PD03] to [Pr. PD05].		
9	Reverse rotation stroke end (LSN)				
10	Point table No. selection 1 to 8/next station selection 1 to 8 (DI0 to DI7)	Supported	Not supported	Set it with the link device (RWwn).	
11	Speed selection 1 to 3 (SP0 to SP2)	Supported	Not supported		
12	Point table No. output 1 to 8/station output 1 to 8 (PT0 to PT7)	Supported	Not supported	Read it with the link device (RWrn).	
13	Internal torque limit selection (TL1)	Supported	Supported		

(4) Other

Item		Difference in specifications		Handling methods on MR-J4-_GF_
		MR-J3-_T_	MR-J4-_GF_	
1	RS-422 communication	Supported	Not supported	The MR-J4-_GF_ is not supported.
2	Manual pulse generator operation	Supported	Not supported	

Part 7: Review on Replacement of MR-J3-_T_ (CC-Link communication operation) with MR-J4-_GF_

3.2 Configuration including peripheral equipment

(1) MR-J3-_T_ (CC-Link communication)

The figure is for MR-J3-100T or less with 3-phase or 1-phase 200 V AC to 230 V AC.

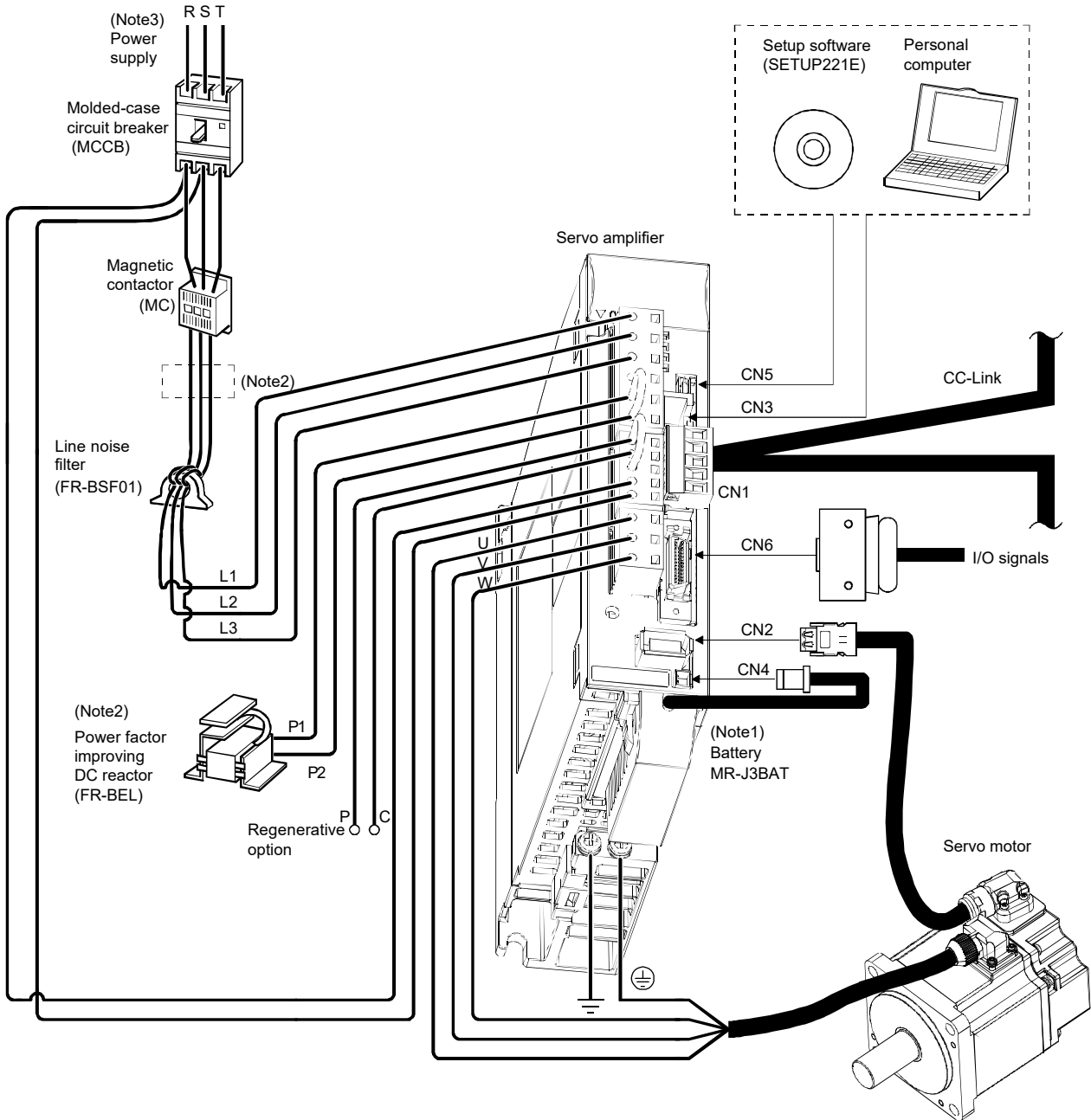

- Note
1. The battery is available as an option. It is used for the absolute position detection system.
 2. The power factor improving AC reactor can also be used. In this case, the power factor improving DC reactor cannot be used. If not using the power factor improving DC reactor, short-circuit P₁ and P₂.
 3. 1-phase 200 V AC to 230 V AC is supported by MR-J3-70T or lower. For 1-phase 200 V AC to 230 V AC power supply, connect the power supply to L₁ and L₂. Leave L₃ Open. For the power supply specifications, refer to "3.1 Function comparison table" (3).

(2) MR-J4-_GF_

The figure is an example of MR-J4-20GF-RJ.

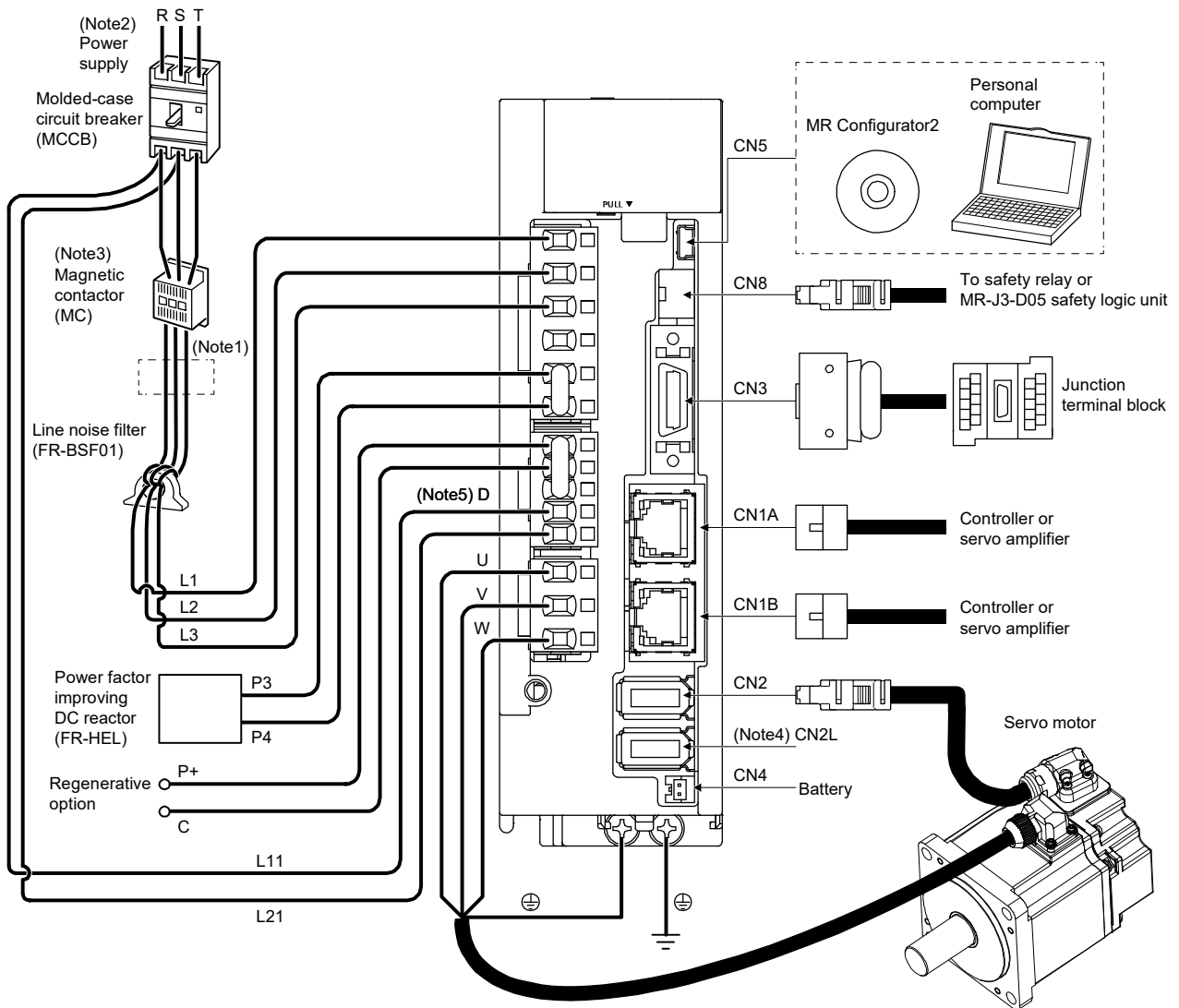

- Note 1. The power factor improving AC reactor can also be used. In this case, the power factor improving DC reactor cannot be used. If not using the power factor improving DC reactor, short-circuit P3 and P4.
- Note 2. For 1-phase 200 V AC to 240 V AC power supply, connect the power supply to L1 and L3. Leave L2 open. For the power supply specifications, refer to section 1.3 of "MR-J4-_GF_ (-RJ) Servo Amplifier Instruction Manual (Motion Mode)".
- Note 3. The bus voltage may drop depending on the main circuit power supply voltage and operation pattern, causing a dynamic brake deceleration during a forced stop deceleration. If dynamic brake deceleration is not required, delay the time to turn off the magnetic contactor.
- Note 4. This is for the MR-J4-_GF_ -RJ servo amplifier. The MR-J4-_GF_ servo amplifier does not have the CN2L connector.
- Note 5. Always connect P+ and D terminals. To use the regenerative option, refer to section 11.2 of "MR-J4-_GF_ (-RJ) Servo Amplifier Instruction Manual (Motion Mode)".

3.3 List of Corresponding Connectors and Terminal Blocks

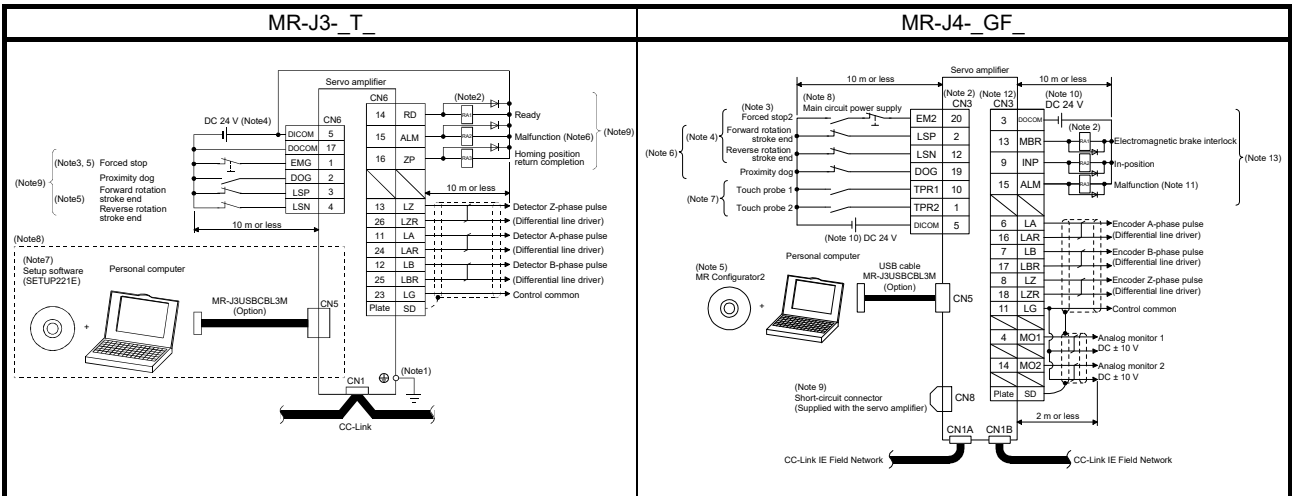

- Note 1. To prevent an electric shock, always connect the protective earth (PE) terminal (the terminal marked with the \oplus symbol) of the servo amplifier to the protective earth (PE) of the cabinet.
2. Connect the diode in the correct direction. If it is connected reversely, the servo amplifier may malfunction and not output signals, disabling protective circuits such as Forced stop (EMG).
 3. Always install a forced stop switch (normally closed contact).
 4. Supply 24 V DC $\pm 10\%$ 150 mA to interfaces from an external source. The amperage will not exceed 150 mA when all I/O signals are used. Reducing the number of I/O points decreases the current capacity. Refer to 4.8.2 (1) of "MR-J3-_T_ Servo Amplifier Instruction Manual" for information on the currents required for interfaces.
 5. Always turn on Forced stop (EMG) and Forward/Reverse rotation stroke end (LSP/LSN) during operation. (Normally closed contact)
 6. Malfunction (ALM) turns on in an operation with no alarms. (Normally closed contact)
 7. Use the MRJZW3-SETUP221E.
 8. A personal computer or parameter unit can also be connected using RS-422 communication on the CN3 connector. However, the USB communication function (CN5 connector) and RS-422 communication function (CN3 connector) are mutually exclusive. They cannot be used at the same time.

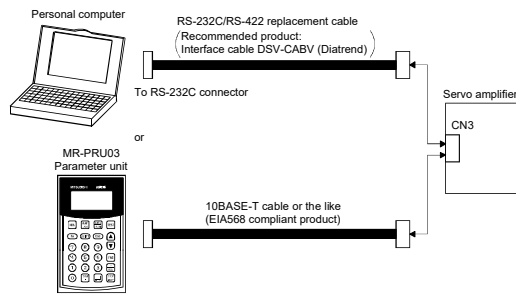

9. This diagram shows a sink I/O interface. For the source I/O interface, refer to section 4.8.3 of "MR-J3-_T_ Servo Amplifier Instruction Manual".

- Note 1. To prevent an electric shock, always connect the protective earth (PE) terminal (the terminal marked with the \oplus symbol) of the servo amplifier to the protective earth (PE) of the cabinet.
2. Connect the diode in the correct direction. If it is connected reversely, the servo amplifier may malfunction and not output signals, disabling protective circuits such as EM2 (Forced stop 2).
 3. If the controller does not have the forced stop function, always install a forced stop 2 switch (normally closed contact).
 4. When starting operation, always turn on EM2 (Forced stop 2), LSP (Forward rotation stroke end), and LSN (Reverse rotation stroke end). If FLS (Upper stroke limit) and RLS (Lower stroke limit) are used via a (normally closed contact) controller, wiring LSP and LSN is unnecessary. In that case, set [Pr. PD41].
 5. Use SW1DNC-MRC2-_.
 6. The devices of these pins can be changed with [Pr. PD03], [Pr. PD04], and [Pr. PD05].
 7. This device can be used only on the MR-J4-_GF_-RJ.
 8. To prevent an unexpected restart of the servo amplifier, configure a circuit that turns off EM2 when the main circuit power supply is turned off.
 9. If not using the STO function, attach the short-circuit connector that came with the servo amplifier.
 10. Supply 24 V DC $\pm 10\%$ to interfaces from an external source. The total current capacity of these power supplies is 300 mA maximum. The amperage will not exceed 300 mA when all I/O signals are used. Reducing the number of I/O points decreases the current capacity. For the current required for the interface, refer to section 3.8 of "MR-J4-_GF_ (-RJ) Servo Amplifier Instruction Manual (Motion Mode)".
 11. ALM (Malfunction) turns on in an operation with no alarms. (Normally closed contact)
 12. The pins with the same signal name are connected in the servo amplifier.
 13. The devices of these pins can be changed with [Pr. PD07], [Pr. PD08], and [Pr. PD09].

Part 7: Review on Replacement of MR-J3-_T_ (CC-Link communication operation) with MR-J4-_GF_

3.4 List of supported connectors and terminal blocks

(1) Connector comparison table

An example of connection with peripheral equipment is shown below. Refer to each servo amplifier instruction manual for details on signals.

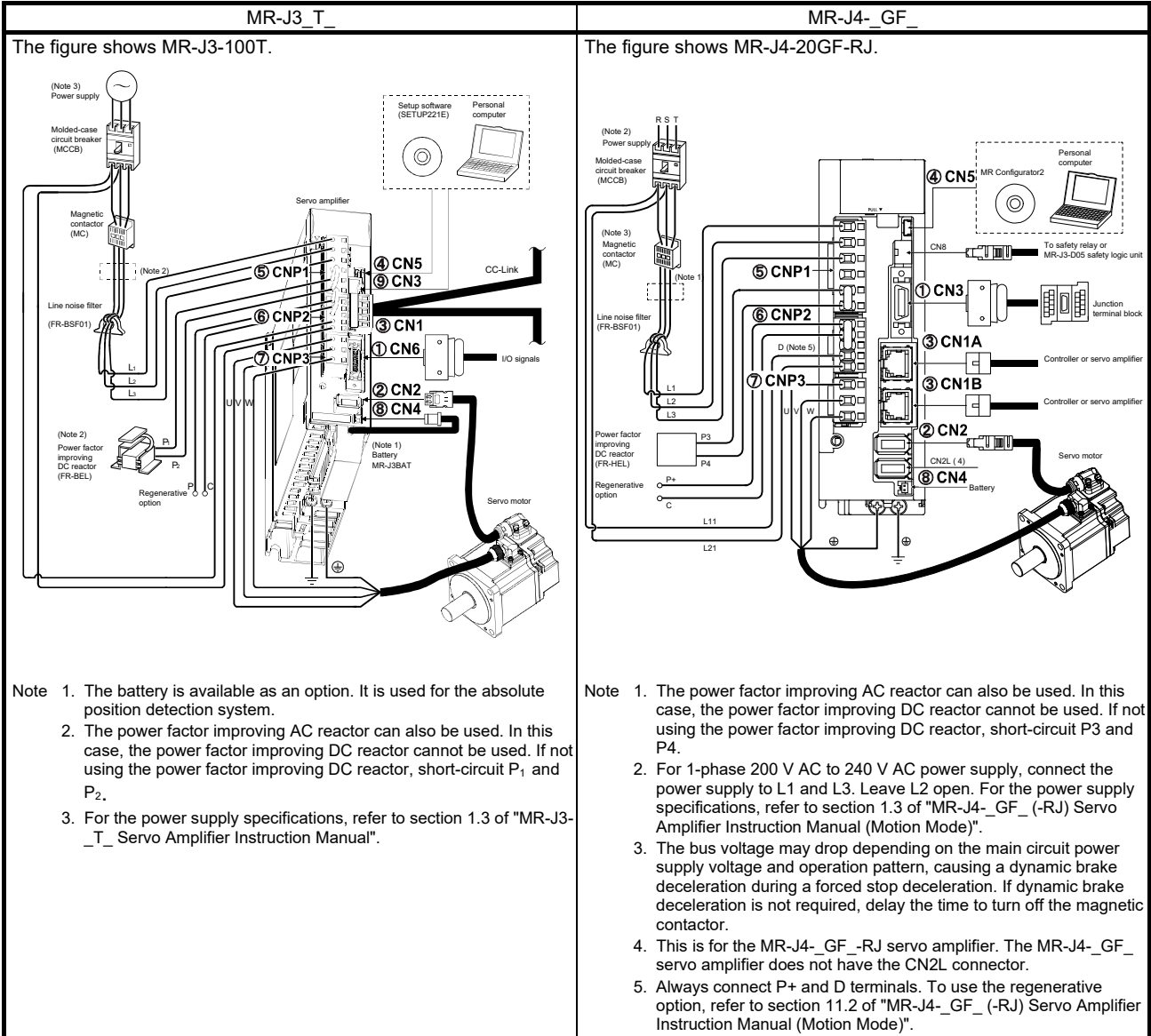

Part 7: Review on Replacement of MR-J3-_T_ (CC-Link communication operation) with MR-J4-_GF_

(2) List of connectors and terminal blocks

MR-J3-_T_			MR-J4-_GF_			Precautions
No.	Connector name	Connector number	No.	Connector name	Connector number	
①	I/O signal connector	CN6	①	I/O signal connector	CN3	New arrangement required
②	Detector connector	CN2	②	Encoder connector	CN2	Changes are required for models of the HG-JR 1000 r/min series with 15 kW or more and the HG-JR 1500 r/min series with 22 kW or more. (CN2L is not used.)
③	Communication connector	CN1	③	Ethernet cable connector	CN1A	MR-J4-_GF_ requires a communication connector for CC-Link IE Field Network.
					CN1B	
④	USB communication connector	CN5	④	USB communication connector	CN5	
⑤	Main circuit power connector	CNP1	⑤	Main circuit power connector	CNP1	It is necessary to switch the power connector (supplied with the servo amplifier).
⑥	Control circuit power connector	CNP2	⑥	Control circuit power connector	CNP2	
⑦	Servo motor power output connector	CNP3	⑦	Servo motor power output connector	CNP3	
⑧	Battery connector	CN4	⑧	Battery connector	CN4	New arrangement for battery required
⑨	RS-422 communication connector	CN3				

Note. When the STO function is not used with MR-J4-_GF_, install the short-circuit connector attached to the servo amplifier on CN8 (STO input signal connector).

The configuration of the main circuit terminal block differs depending on the capacity. Refer to "Part 8: Common Documents" for details.

Part 7: Review on Replacement of MR-J3-_T_ (CC-Link communication operation) with MR-J4-_GF_

(3) Signal comparison

(a) MR-J3-_T_/MR-J4-_GF_ common

The signal in () is unique to MR-J4-_GF_.

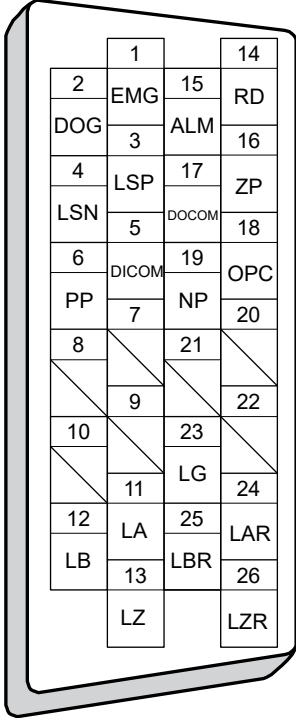
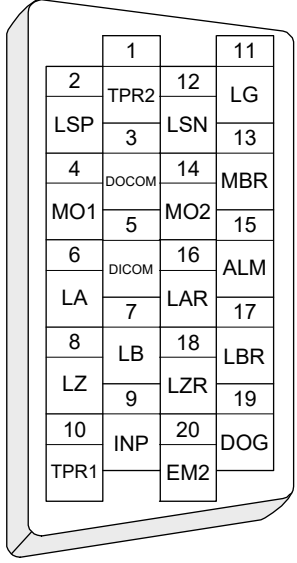
MR-J3-_T_		Signal abbreviation	MR-J4-_GF_	
Connector signal arrangement	Connector pin No.		Connector pin No.	Connector signal arrangement
	CN6-1	EMG (EM2)	CN3-20 (Note)	
	CN6-2	DOG	CN3-19	
	CN6-3	LSP	CN3-2	
	CN6-4	LSN	CN3-12	
	CN6-5	DICOM	CN3-5	
	CN6-6	PP		
	CN6-7			
	CN6-8			
	CN6-9			
	CN6-10			
	CN6-11	LA	CN3-6	
	CN6-12	LB	CN3-7	
	CN6-13	LZ	CN3-8	
	CN6-14	RD		
	CN6-15	ALM	CN3-15	
	CN6-16	ZP		
	CN6-17	DOCOM	CN3-3	
	CN6-18	OPC		
	CN6-19	NP		
	CN6-20			
	CN6-21			
	CN6-22			
	CN6-23	LG	CN3-11	
	CN6-24	LAR	CN3-16	
	CN6-25	LBR	CN3-17	
	CN6-26	LZR	CN3-18	

Note. EM2 is assigned to the CN3-20 pin as the initial value. To make the same setting as MR-J3-_T_, set this to "Forced stop deceleration function disabled (EM1 is used)". To use EM1, set [Pr. PA04] to "0 _ _ _" to enable it.

Part 7: Review on Replacement of MR-J3-_T_ (CC-Link communication operation) with MR-J4-_GF_

(b) CN3 (MR-J4-_GF_ only)

MR-J3-_T_		Signal abbreviation	MR-J4-_GF_	
Connector signal arrangement	Connector pin No.		Connector pin No.	Connector signal arrangement
		MO1	CN3-4	
		MO2	CN3-14	
		TRP1	CN3-10	
		TRP2	CN3-1	
		INP	CN3-9 (Note)	
		MBR	CN3-13 (Note)	

Note. The devices of these pins can be changed with [Pr. PD03], [Pr. PD04], and [Pr. PD05].

Part 7: Review on Replacement of MR-J3-_T_ (CC-Link communication operation) with MR-J4-_GF_

3.5 Peripheral equipment compatibility comparison

POINT
● See Part 10: Review on Replacement of Optional Peripheral Equipment.

3.5.1 MR-J3-_T_/MR-J4-_GF_

The items shown in the following table are not compatible in MR-J3-_T_ and MR-J4-_GF_.

When replacing, prepare a new one for MR-J4-_GF_. For details, refer to "MR-J4-_GF_(-RJ) Servo Amplifier Instruction Manual (Motion Mode)".

I/O signal connector connection junction terminal block/junction terminal block cable/junction terminal block connector set

Item	MR-J3-_T_	MR-J4-_GF_
Junction terminal block		PS7DW-20V14B-F (recommended product)
Junction terminal block cable		MR-J2HBUS_M
Junction terminal block connector set	MR-J2CMP2	MR-CCN1

3.6 Parameter comparison



CAUTION

- Never make a drastic adjustment or change to the parameter values as doing so will make the operation unstable.
- If a fixed value is described for each digit of the parameter, never change the value of that digit.
- Do not change the parameters for manufacturer setting.
- For each parameter value, only set the setting value that is listed in the following table.

POINT

- When replacing MR-J3-_T_ (CC-Link communication operation) with MR-J4-_GF_, set [Pr. PN03] to "___ 1" (I/O mode).
- Refer to "Part 8: Common Documents" for the parameter converter function.
- For MR-J3-_T_, the parameters in which the symbols are preceded by * are enabled when the power is turned off and turned on again after setting.
- For MR-J4-_GF_, the parameters in which the symbols are preceded by * are enabled by the following conditions.
 - *: After setting, turn off the power and turn it on again, or reset the controller.
 - ** : After setting, turn off the power and turn it on again.
- For details on parameter setting for replacement, refer to "MR-J4-_GF_ (-RJ) Servo Amplifier Instruction Manual (Motion Mode)" and "MR-J4-_GF_ (-RJ) Servo Amplifier Instruction Manual (I/O mode)".
- In MR-J4-_GF_, the deceleration to a stop function is enabled in the factory setting. When not using the deceleration to a stop function, set [Pr. PA04] to "0 ___".
- Set [Pr. PA19] to "00AB" to enable reading and writing of positioning control parameters ([Pr. PT__]) and network setting parameters ([Pr. PN__]).

Part 7: Review on Replacement of MR-J3-_T_ (CC-Link communication operation) with MR-J4-_GF_

3.6.1 Parameters required to be set when replacing

The parameters shown here are the parameters that need to be set at the minimum when replacing servo amplifiers all at once. Note that it may be necessary to set parameters other than the ones shown here depending on the settings of the existing servo amplifier.

MR-J3-_T_ (CC-Link communication operation)		MR-J4-_GF_		Precautions
No.	Name	No.	Name	
PA01	Control mode	PA01	Operation mode	Refer to "3.6.3 Comparison of parameter details" for details.
		PT01	Command mode selection	
		PN03	Communication mode setting for CC-Link IE communication	
PA02	Regenerative option	PA02	Regenerative option	
PA03	Absolute position detection system	PA03	Absolute position detection system	
PA05	Feed function selection	PT03	Feed function selection	
PA06	Electronic gear numerator (command input pulse multiplication numerator)/number of gear teeth on machine side	PA06	Electronic gear numerator (command pulse multiplication numerator)/number of gear teeth on machine side	
PA07	Electronic gear denominator (command input pulse multiplication denominator)/number of gear teeth on servo motor side	PA07	Electronic gear denominator (command pulse multiplication denominator)/number of gear teeth on servo motor side	
PA08	Auto tuning mode	PA08	Auto tuning mode	
PA09	Auto tuning response	PA09	Auto tuning response	
PA10	In-position range	PA10	In-position range	
PA11	Forward rotation torque limit	PA11	Forward rotation torque limit	
PA12	Reverse rotation torque limit	PA12	Reverse rotation torque limit	
PA14	Rotation direction selection/station No. direction selection	PA14	Rotation direction selection/station number direction selection	
PA15	Detector output pulse	PA15	Encoder output pulses	
PA19	Parameter writing prohibited	PA19	Parameter writing prohibited	Set [Pr. PA19] to "0 0 A B" to enable reading and writing of positioning control parameters ([Pr. PT_]) and network setting parameters ([Pr. PN_]).
PB06	Load to motor inertia ratio	PB06	Load to motor inertia ratio	The unit system is different. (0.1 multiplier → 0.01 multiplier) Be careful with the setting value.
PB07	Model control gain	PB07	Model control gain	The unit system is different. (rad/s → 0.1 rad/s) The initial value is different. Be careful with the setting value.
PB08	Position control gain	PB08	Position control gain	The unit system is different. (rad/s → 0.1 rad/s) Be careful with the setting value.
PB12	For manufacturer setting	PB12	Overshoot amount compensation	Refer to "3.6.3 Comparison of parameter details" for details.
PB17	Automatic setting parameter	PB17	Shaft resonance suppression filter	
PB23	Low-pass filter selection	PB23	Low-pass filter selection	
PB29	Gain switching - Load to motor inertia ratio	PB29	Gain switching - Load to motor inertia ratio	The unit system is different. (0.1 multiplier → 0.01 multiplier) Be careful with the setting value.
PB30	Gain switching - Position control gain	PB30	Gain switching - Position control gain	The unit system is different. (rad/s → 0.1 rad/s) The initial value is different. Be careful with the setting value.
PB31	Gain switching - Speed control gain	PB31	Gain switching - Speed control gain	The initial value is different. Be careful with the setting value.
PB32	Speed integral compensation after gain switching	PB32	Speed integral compensation after gain switching	
PB33	Gain switching - Vibration suppression control - Vibration frequency	PB33	Gain switching - Vibration suppression control 1 - Vibration frequency	
PB34	Gain switching - Vibration suppression control - Resonance frequency	PB34	Gain switching - Vibration suppression control 1 - Resonance frequency	

Part 7: Review on Replacement of MR-J3-_T_ (CC-Link communication operation) with MR-J4-_GF_

MR-J3-_T_ (CC-Link communication operation)		MR-J4-_GF_		Precautions
No.	Name	No.	Name	
PC02	Home position return type	PT45	Homing methods	Refer to "3.6.3 Comparison of parameter details" for details.
PC03	Homing direction	PT70	Function selection T-10	
PC04	Homing speed	PT05	Homing speed	
PC05	Creep speed	PT06	Creep speed	
PC06	Home position shift distance	PT07	Home position shift distance	
		PT69	Home position shift distance (extension parameter)	
PC07	Homing position data	PT08	Homing position data	
		PT47	Home position return position data (extension parameter)	
PC08	Travel distance after proximity dog	PT09	Travel distance after proximity dog	
		PT71	Travel distance after proximity dog (extension parameter)	
PC09	Stopper type homing - Stopping time	PT10	Stopper type homing - Stopping time	
PC10	Stopper type homing - Torque limit value	PT11	Stopper type homing - Torque limit value	
PC11	Rough match output range	PT12	Rough match output range	
PC12	JOG speed	PT65	JOG speed command	
PC13	S-pattern acceleration/deceleration time constants	PT51	S-pattern acceleration/deceleration time constants	
PC14	Backlash compensation	PT14	Backlash compensation	
PC16	Electromagnetic brake sequence output	PC02	Electromagnetic brake sequence output	The initial value is different. Be careful with the setting value.
PC24	Function selection C-3	PC06	Function selection C-3	Refer to "3.6.3 Comparison of parameter details" for details.
PC26	Function selection C-5	PC19	Function selection C-6	
PC27	Function selection C-6	PC20	Function selection C-7	
PC28	Function selection C-7	PT26	Function selection T-2	
PC30	Remote register-based position/speed specifying method selection	PT62	Remote register-based position/speed specifying method selection	
PC31	Software limit +	PT15	Software limit + (last 4 digits)	
PC32		PT16	Software limit + (first 4 digits)	
PC33	Software limit -	PT17	Software limit - (last 4 digits)	
PC34		PT18	Software limit - (first 4 digits)	
PC35	Internal torque limit 2	PC77	Internal torque limit 2	
		PT48	Function selection T-7A	
PC37	Position range output address +	PT19	Position range output address + (last 4 digits)	Refer to "3.6.3 Comparison of parameter details" for details.
PC38		PT20	Position range output address + (first 4 digits)	
PC39	Position range output address -	PT21	Position range output address - (last 4 digits)	
PC40		PT22	Position range output address - (first 4 digits)	
PC45	Function selection C-9	PT27	Indexer method - Operation mode selection	
PC46	Number of stations/rotation for indexer positioning operation	PT28	Number of stations per rotation	
PC47	Station home position shift distance for indexer positioning operation	PT40	Station home position shift distance	
PC50	Function selection C-A	PT62	Remote register-based position/speed specifying method selection	
PD01	Input signal automatic ON selection 1	PD01	Input signal automatic ON selection 1	Refer to "3.6.3 Comparison of parameter details" for details.
PD06	Input signal device selection 2 (CN6-2)	PD03	Input device selection 1 (CN3-2)	Assign the input device assigned to the CN6-2, CN6-3, and CN6-4 pins of MR-J3-_T_ to any of the pins of MR-J4-_GF_. Refer to "3.6.3 Comparison of parameter details" for details.
PD07	Input signal device selection 3 (CN6-3)	PD04	Input device selection 2 (CN3-12)	
PD08	Input signal device selection 4 (CN6-4)	PD05	Input device selection 3 (CN3-19)	
PD12	External DI function selection 1			
PD09	Output signal device selection 1 (CN6-14)	PD07	Output device selection 1 (CN3-13)	Assign the output device assigned to the CN6-14 pin, CN6-15 pin, and CN6-16 pin of MR-J3-_T_ to one of the following pins of MR-J4-_GF_. Refer to "3.6.3 Comparison of parameter details" for details.
PD10	Output signal device selection 2 (CN6-15)	PD08	Output device selection 2 (CN3-9)	
PD11	Output signal device selection 3 (CN6-16)	PD09	Output device selection 3 (CN3-15)	
PD12	External DI function selection 1	PD41	Function selection D-4	Refer to "3.6.3 Comparison of parameter details" for details.
PD14	External DI function selection 3			
PD16	Input polarity selection	PT29	Function selection T-3	
PD19	Input filter setting	PD11	Input filter setting	
PD20	Function selection D-1	PD12	Function selection D-1	
PD22	Function selection D-3	PD42	Function selection D-5	
PD24	Function selection D-5	PD14	Function selection D-3	

Part 7: Review on Replacement of MR-J3-_T_ (CC-Link communication operation) with MR-J4-_GF_

3.6.2 Parameter comparison list

MR-J3-_T_ (CC-Link communication operation) parameter					Corresponding MR-J4-_GF_ parameter				
No.	Symbol	Parameter name	Initial value	Customer setting value	No.	Symbol	Parameter name	Initial value	Customer setting value
PA01	*STY	Control mode	0000h		PA01	**STY	Operation mode	1000h	
					PT01	**CTY	Command mode selection	0300h	
					PN03	**NWMD	Communication mode setting for CC-Link IE communication	0000h	
PA02	*REG	Regenerative option	0000h		PA02	*REG	Regenerative option	0000h	
PA03	*ABS	Absolute position detection system	0000h		PA03	*ABS	Absolute position detection system selection	0000h	
PA04	*AOP1	Function selection A-1	0000h				No corresponding parameter		
PA05	*FTY	Feed function selection	0000h		PT03	*FTY	Feed function selection	0000h	
PA06	*CMX	Electronic gear numerator (command input pulse multiplication numerator)/number of gear teeth on machine side	1		PA06	*CMX	Electronic gear numerator (command pulse multiplication numerator)/number of gear teeth on machine side	1	
PA07	*CDV	Electronic gear denominator (command input pulse multiplication denominator)/number of gear teeth on servo motor side	1		PA07	*CDV	Electronic gear denominator (command pulse multiplication denominator)/number of gear teeth on servo motor side	1	
PA08	ATU	Auto tuning mode	0001h		PA08	ATU	Auto tuning mode	0001h	
PA09	RSP	Auto tuning response	12		PA09	RSP	Auto tuning response	16	
PA10	INP	In-position range	100		PA10	INP	In-position range	1600	
PA11	TLP	Forward rotation torque limit	100.0		PA11	TLP	Forward rotation torque limit	1000.0	
PA12	TLN	Reverse rotation torque limit	100.0		PA12	TLN	Reverse rotation torque limit	1000.0	
PA14	*POL	Rotation direction selection/station No. direction selection	0		PA14	*POL	Servo motor rotation direction selection/station No. direction selection	0	
PA15	*ENR	Detector output pulse	4000		PA15	*ENR	Encoder output pulses	4000	
PA19	*BLK	Parameter writing prohibited	000Ch		PA19	*BLK	Parameter writing prohibited	00ABh	
PB01	FILT	Adaptive tuning mode (adaptive filter II)	0000h		PB01	FILT	Adaptive tuning mode (adaptive filter II)	0000h	
PB02	VRFT	Vibration suppression control tuning mode (Advanced vibration suppression control)	0000h		PB02	VRFT	Vibration suppression control tuning mode (Advanced vibration suppression control II)	0000h	
PB04	FFC	Feed forward gain	0		PB04	FFC	Feed forward gain	0	
PB06	GD2	Load to motor inertia ratio	7.0		PB06	GD2	Load to motor inertia ratio	7.00	
PB07	PG1	Model control gain	24		PB07	PG1	Model control gain (Note)	15.0	
PB08	PG2	Position control gain	37		PB08	PG2	Position control gain (Note)	37.0	
PB09	VG2	Speed control gain	823		PB09	VG2	Speed control gain (Note)	823	
PB10	VIC	Speed integral compensation	33.7		PB10	VIC	Speed integral compensation (Note)	33.7	
PB11	VDC	Speed differential compensation	980		PB11	VDC	Speed differential compensation (Note)	980	
PB12		For manufacturer setting	0		PB12	OVA	Overshoot amount compensation	0	
PB13	NH1	Machine resonance suppression filter 1	4500		PB13	NH1	Machine resonance suppression filter 1	4500	
PB14	NHQ1	Notch shape selection 1	0000h		PB14	NHQ1	Notch shape selection 1	0000h	
PB15	NH2	Machine resonance suppression filter 2	4500		PB15	NH2	Machine resonance suppression filter 2	4500	
PB16	NHQ2	Notch shape selection 2	0000h		PB16	NHQ2	Notch shape selection 2	0000h	
PB17		Automatic setting parameter			PB17	NHF	Shaft resonance suppression filter	0000h	
PB18	LPF	Low-pass filter setting	3141		PB18	LPF	Low-pass filter setting	3141	
PB19	VRF1	Vibration suppression control - Vibration frequency	100.0		PB19	VRF11	Vibration suppression control 1 - Vibration frequency	100.0	
PB20	VRF2	Vibration suppression control - Resonance frequency	100.0		PB20	VRF12	Vibration suppression control 1 - Resonance frequency	100.0	
PB23	VFBF	Low-pass filter selection	0000h		PB23	VFBF	Low-pass filter selection	0000h	
PB24	*MVS	Slight vibration suppression control selection	0000h		PB24	*MVS	Slight vibration suppression control	0000h	
PB26	*CDP	Gain switching selection	0000h		PB26	*CDP	Gain switching function	0000h	
PB27	CDL	Gain switching condition	10		PB27	CDL	Gain switching condition	10	
PB28	CDT	Gain switching time constant	1		PB28	CDT	Gain switching time constant	1	
PB29	GD2B	Load to motor inertia ratio after gain switching	7.0		PB29	GD2B	Gain switching - Load to motor inertia ratio	7.00	

Part 7: Review on Replacement of MR-J3-_T_ (CC-Link communication operation) with MR-J4-_GF_

MR-J3-_T_ (CC-Link communication operation) parameter					Corresponding MR-J4-_GF_ parameter				
No.	Symbol	Parameter name	Initial value	Customer setting value	No.	Symbol	Parameter name	Initial value	Customer setting value
PB30	PG2B	Gain switching - Position control gain	37		PB30	PG2B	Gain switching - Position control gain	0.0	
PB31	VG2B	Gain switching - Speed control gain	823		PB31	VG2B	Gain switching - Speed control gain	0	
PB32	VICB	Speed integral compensation after gain switching	33.7		PB32	VICB	Speed integral compensation after gain switching	0.0	
PB33	VRF1B	Gain switching - Vibration suppression control - Vibration frequency	100.0		PB33	VRF1B	Gain switching - Vibration suppression control 1 - Vibration frequency	0.0	
PB34	VRF2B	Gain switching - Vibration suppression control - Resonance frequency	100.0		PB34	VRF2B	Gain switching - Vibration suppression control 1 - Resonance frequency	0.0	

Note. The parameters related to gain adjustment are different from those of the MR-J3-_T_ servo amplifier. For the gain adjustment method, refer to "MR-J4-_GF_(-RJ) Servo Amplifier Instruction Manual (Motion Mode)".

Part 7: Review on Replacement of MR-J3-_T_ (CC-Link communication operation) with MR-J4-_GF_

MR-J3-_T_ parameter					Corresponding MR-J4-_GF_ parameter				
No.	Symbol	Parameter name	Initial value	Customer setting value	No.	Symbol	Parameter name	Initial value	Customer setting value
PC02	*ZTY	Home position return type	0000h		PT45	HMM	Homing methods	37	
PC03	*ZDIR	Homing direction	0001h		PT70	TOP10	Function selection T-10	0000h	
PC04	ZRF	Homing speed	500		PT05	ZRF	Homing speed	100.00	
PC05	CRF	Creep speed	10		PT06	CRF	Creep speed	10.00	
PC06	ZST	Home position shift distance	0		PT07	ZST	Home position shift distance	0	
					PT69	ZSTH	Home position shift distance (extension parameter)	0	
PC07	*ZPS	Homing position data	0		PT08	*ZPS	Homing position data	0	
					PT47	*ZPSH	Home position return position data (extension parameter)	0	
PC08	DCT	Travel distance after proximity dog	1000		PT09	DCT	Travel distance after proximity dog	0	
					PT71	DCTH	Travel distance after proximity dog (extension parameter)	0	
PC09	ZTM	Stopper type homing - Stopping time	100		PT10	ZTM	Stopper type homing - Stopping time	100	
PC10	ZTT	Stopper type homing - Torque limit value	15.0		PT11	ZTT	Stopper type homing - Torque limit value	15.0	
PC11	CRP	Rough match output range	0		PT12	CRP	Rough match output range	0	
PC12	JOG	JOG speed	100		PT65	PVC	JOG speed command	100.00	
PC13	*STC	S-pattern acceleration/deceleration time constants	0		PT51	STC	S-pattern acceleration/deceleration time constants	0	
PC14	*BKC	Backlash compensation	0		PT14	*BKC	Backlash compensation	0	
PC16	MBR	Electromagnetic brake sequence output	100		PC02	MBR	Electromagnetic brake sequence output	0	
PC17	ZSP	Zero speed	50		PC07	ZSP	Zero speed	50	
PC18	*BPS	Alarm history clear	0000h		PC21	*BPS	Alarm history clear	0000h	
PC19	*ENRS	Detector output pulse selection	0000h		PC03	*ENRS	Encoder output pulses selection	0000h	
PC20	*SNO	Setting station numbers	0				No corresponding parameter		
PC21	*SOP	RS-422 communication function selection	0000h				No corresponding parameter		
PC22	*COP1	Function selection C-1	0000h		PC04	**COP1	Function selection C-1	0000h	
PC24	*COP3	Function selection C-3	0000h		PC06	*COP3	Function selection C-3	0000h	
PC26	*COP5	Function selection C-5	0000h		PC19	*COP5	Function selection C-5	0000h	
PC27	*COP6	Function selection C-6	0000h		PC20	*COP6	Function selection C-6	0000h	
PC28	*COP7	Function selection C-7	0000h		PT26	*TOP2	Function selection T-2	0000h	
PC30	*DSS	Remote register-based position/speed specifying method selection	0000h		PT62	*DSS	Remote register-based position/speed specifying method selection	0000h	
PC50	*COPA	Function selection C-A	0000h						
PC31	LMPL	Software limit +	0		PT15	LMPL	Software limit +	0000h	
PC32	LMPH				PT16	LMPH		0000h	
PC33	LMNL	Software limit -	0		PT17	LMNL	Software limit -	0000h	
PC34	LMNH				PT18	LMNH		0000h	
PC35	TL2	Internal torque limit 2	100.0		PC77	TL2	Internal torque limit 2	0.0	
					PT48	TOP7A	Function selection T-7A	0000h	
PC37	*LPPL	Position range output address +	0		PT19	*LPPL	Position range output address +	0000h	
PC38	*LPPH				PT20	*LPPH		0000h	
PC39	*LNPL	Position range output address -	0		PT21	*LNPL	Position range output address -	0000h	
PC40	*LNPH				PT22	*LNPH		0000h	
PC45	*COP9	Function selection C-9	0000h		PT27	*ODM	Indexer method - Operation mode selection	0000h	
PC46	*STN	Number of stations/rotation for indexer positioning operation	0000h		PT28	*STN	Number of stations per rotation	8	
PC47	PSST	Station home position shift distance for indexer positioning operation	0000h		PT40	*SZS	Station home position shift distance	0	

Part 7: Review on Replacement of MR-J3-_T_ (CC-Link communication operation) with MR-J4-_GF_

MR-J3-_T_ parameter					Corresponding MR-J4-_GF_ parameter				
No.	Symbol	Parameter name	Initial value	Customer setting value	No.	Symbol	Parameter name	Initial value	Customer setting value
PD01	*DIA1	Input signal automatic ON selection 1	0000h		PD01	*DIA1	Input signal automatic ON selection 1	0000h	
					PA04	*AOP1	Function selection A-1	2000h	
					PB24	*MVS	Slight vibration suppression control	0000h	
PD03	*DIA3	Input signal automatic ON selection 3	0000h				No corresponding parameter		
PD04	*DIA4	Input signal automatic ON selection 4	0000h				No corresponding parameter		
PD06	*DI2	Input signal device selection 2 (CN6-2)	002Bh		PD03	*DI1	Input device selection 1	000Ah	
PD07	*DI3	Input signal device selection 3 (CN6-3)	000Ah		PD04	*DI2	Input device selection 2	000Bh	
PD08	*DI4	Input signal device selection 4 (CN6-4)	000Bh		PD05	*DI3	Input device selection 3	0022h	
PD09	*DO1	Output signal device selection 1 (CN6-14)	0002h		PD07	*DO1	Output device selection 1	0005h	
PD10	*DO2	Output signal device selection 2 (CN6-15)	0003h		PD08	*DO2	Output device selection 2	0004h	
PD11	*DO3	Output signal device selection 3 (CN6-16)	0024h		PD09	*DO3	Output device selection 3	0003h	
PD12	*DIN1	External DI function selection 1	0C00h				No corresponding parameter		
PD14	*DIN2	External DI function selection 3	0800h				No corresponding parameter		
PD16	*DIAB	Input polarity selection	0000h		PT29	*TOP3	Function selection T-3	0000h	
PD19	*DIF	Input filter setting	0002h		PD11	*DIF	Input filter	0004h	
PD20	*DOP1	Function selection D-1	0010h		PD12	*DOP1	Function selection D-1	0101h	
PD22	*DOP3	Function selection D-3	0000h		PD42	*DOP5	Function selection D-5	0000h	
PD24	*DOP5	Function selection D-5	0000h		PD14	*DOP3	Function selection D-3	0000h	
PD25	A8DT	CC-Link communication error (A8D) detection time	0000h		PN02	CERT	Communication error detection time	0	
PD26	TLT	Indexer positioning operation torque limit ready time	0064h		PT39	INT	Torque limit delay time	100	

Part 7: Review on Replacement of MR-J3-_T_ (CC-Link communication operation) with MR-J4-_GF_

3.6.3 Parameter detail comparison

POINT
<ul style="list-style-type: none"> ● If a value out of the setting range is set to each parameter, [AL. 37 Parameter error] occurs. ● The symbols in the control mode indicate the following control modes. CP: Positioning mode (point table method) PS: Positioning mode (indexer method) SP: Speed control mode (point table method)

MR-J3-_T_			MR-J4-_GF_				
No.	Name and function	Initial value	No.	Name and function	Initial value	Control mode	
PA01	Control mode __ 0 x: Command method selection 0: Absolute value command method 1: Incremental value command method	0000h	PA01	Operation mode ___ x: Control mode selection Select a control mode. 0: Positioning mode (point table method) 8: Positioning mode (indexer method) B: Speed control mode (point table method) When [Pr. PN03] = ___ 1, the above settings are enabled.	0h	CP PS SP	
							__ x 0 _: 350% maximum torque setting of HF-KP series servo motor 0: Disabled 3: Enabled
							x _ 0 _: Operation method 0: Point table positioning operation 1: Indexer positioning operation 2: Speed control
		___ x _: Operation mode selection 0: Standard control mode		0h	CP PS SP		
		_ x _ _: For manufacturer setting		0h			
		x _ _ _: For manufacturer setting		1h			
		PT01		Command mode selection ___ x: Positioning command method selection 0: Absolute value command method 1: Incremental value command method	0h	CP	
		___ x _: For manufacturer setting		0h			
		_ x _ _: Unit for position data 0: mm The initial value is "3", so reset it to "0".		3h	CP		
		x _ _ _: For manufacturer setting		0h			
		PN03		Communication mode setting for CC-Link IE communication ___ x: Station-specific mode selection Select the I/O mode that can be connected to the master local unit. 1: I/O mode The initial value is "0", so reset it to "1".	0h	CP PS SP	
		___ x _: For manufacturer setting		0h			
	_ x _ _: For manufacturer setting	0h					
	x _ _ _: For manufacturer setting	0h					

Part 7: Review on Replacement of MR-J3-_T_ (CC-Link communication operation) with MR-J4-_GF_

MR-J3-_T_			MR-J4-_GF_						
No.	Name and function	Initial value	No.	Name and function	Initial value	Control mode			
PA02	<p>Regenerative option</p> <p>Incorrect setting may cause the regenerative option to burn.</p> <p>If a selected regenerative option is not for use with the servo amplifier, [AL. 37 Parameter error] occurs.</p> <p>When using the regeneration option, brake unit, power regeneration converter, or power regeneration common converter, set this parameter.</p> <p>0 0 x x:</p> <p>Regenerative option selection</p> <p>00: Regenerative option is not used.</p> <ul style="list-style-type: none"> ▪ For 100 W servo amplifiers, the regenerative resistor is not used. ▪ Built-in regenerative resistors are used on servo amplifiers with a capacity of 200 W to 7 kW. ▪ Use the supplied regenerative resistor or regenerative option on a 11 kW to 22 kW servo amplifier. <p>01: FR-BU2-(H)/FR-RC-(H)/FR-CV-(H)</p> <p>02: MR-RB032</p> <p>03: MR-RB12</p> <p>04: MR-RB32</p> <p>05: MR-RB30</p> <p>06: MR-RB50 (A cooling fan is required.)</p> <p>08: MR-RB31</p> <p>09: MR-RB51 (A cooling fan is required.)</p> <p>80: MR-RB1H-4</p> <p>81: MR-RB3M-4 (A cooling fan is required.)</p> <p>82: MR-RB3G-4 (A cooling fan is required.)</p> <p>83: MR-RB5G-4 (A cooling fan is required.)</p> <p>84: MR-RB34-4 (A cooling fan is required.)</p> <p>85: MR-RB54-4 (A cooling fan is required.)</p> <p>FA: When using a cooling fan to cool the supplied regenerative resistor or regenerative option on a 11 kW to 22 kW servo amplifier to increase the capability</p>	0000h	PA02	<p>Regenerative option</p> <p>__ x x</p> <p>Select a regenerative option.</p> <p>Incorrect setting may cause the regenerative option to burn.</p> <p>If a selected regenerative option is not for use with the servo amplifier, [AL. 37 Parameter error] occurs.</p> <p>00: Regenerative option is not used.</p> <ul style="list-style-type: none"> ▪ For 100 W servo amplifiers, the regenerative resistor is not used. ▪ Built-in regenerative resistors are used on servo amplifiers with a capacity of 0.2 kW to 7 kW. ▪ Use the supplied regenerative resistor or regenerative option on a 11 kW to 22 kW servo amplifier. <p>01: When using FR-RC-(H)/FR-CV-(H)/FR-BU2-(H)/FR-XC-(H)FR-RC-(H), FR-CV-(H), and FR-XC-(H), select "1" for "[AL. 10 Undervoltage] detection method selection" of [Pr. PC20].</p> <p>02: MR-RB032</p> <p>03: MR-RB12</p> <p>04: MR-RB32</p> <p>05: MR-RB30</p> <p>06: MR-RB50 (A cooling fan is required.)</p> <p>08: MR-RB31</p> <p>09: MR-RB51 (A cooling fan is required.)</p> <p>0B: MR-RB3N</p> <p>0C: MR-RB5N (A cooling fan is required.)</p> <p>80: MR-RB1H-4</p> <p>81: MR-RB3M-4 (A cooling fan is required.)</p> <p>82: MR-RB3G-4 (A cooling fan is required.)</p> <p>83: MR-RB5G-4 (A cooling fan is required.)</p> <p>84: MR-RB34-4 (A cooling fan is required.)</p> <p>85: MR-RB54-4 (A cooling fan is required.)</p> <p>91: MR-RB3U-4 (A cooling fan is required.)</p> <p>92: MR-RB5U-4 (A cooling fan is required.)</p> <p>FA: When using a cooling fan to cool the supplied regenerative resistor or regenerative option on a 11 kW to 22 kW servo amplifier to increase the capability</p>	00h	CP PS SP			
							__ x __:	0h	
							x __ __:	0h	
							For manufacturer setting		
PA03	<p>Absolute position detection system</p> <p>0 0 0 x:</p> <p>Absolute position detection system selection</p> <p>0: Use with the incremental system.</p> <p>1: Use with the absolute position detection system.</p>	0000h	PA03	<p>Absolute position detection system</p> <p>__ __ x:</p> <p>Absolute position detection system selection</p> <p>Set this digit when using the absolute position detection system.</p> <p>0: Disabled (incremental system)</p> <p>1: Enabled (absolute position detection system)</p>	0h	CP PS			
							__ __ x:	0h	
							__ x __:	0h	
							x __ __:	0h	
	For manufacturer setting								

Part 7: Review on Replacement of MR-J3-_T_ (CC-Link communication operation) with MR-J4-_GF_

MR-J3-_T_			MR-J4-_GF_																														
No.	Name and function	Initial value	No.	Name and function	Initial value	Control mode																											
PA04	<p>Function selection A-1 0 0 0 x:</p> <p>Follow-up of Servo-on (RYn0)-off and Forced stop (EMG)-off when using the absolute value command method in the incremental system</p> <p>0: Disabled 1: Enabled</p> <p>Normally, when this servo amplifier is used in the absolute value command method of an incremental system, the home position disappears at servo-off or in the forced stop state.</p> <p>If this parameter is set to "1", the home position will not disappear even at servo-off, in the forced stop state, or at occurrence of an alarm that can be canceled by reset.</p> <p>Operation can be resumed again if Servo-on (RYn0) or Forced stop (EMG) is cleared, or if an alarm is canceled using Reset (RES).</p>	0000h		No corresponding parameter																													
PA05	<p>Feed function selection</p> <p>Select the setting unit for feed length multiplication, manual pulse generator input multiplication, and servo motor speed.</p> <p>0 _ _ x:</p> <table border="1" data-bbox="233 927 676 1205"> <thead> <tr> <th rowspan="2">Setting value</th> <th rowspan="2">Feed length multiplication (STM) [Multiplier]</th> <th rowspan="2">Feed unit [μm]</th> <th colspan="2">Position data input range [mm]</th> </tr> <tr> <th>Absolute value command method</th> <th>Incremental value command method</th> </tr> </thead> <tbody> <tr> <td>0</td> <td>1</td> <td>1</td> <td>-999.999 to +999.999</td> <td>0 to +999.999</td> </tr> <tr> <td>1</td> <td>10</td> <td>10</td> <td>-9999.99 to +9999.99</td> <td>0 to +9999.99</td> </tr> <tr> <td>2</td> <td>100</td> <td>100</td> <td>-99999.9 to +99999.9</td> <td>0 to +99999.9</td> </tr> <tr> <td>3</td> <td>1000</td> <td>1000</td> <td>-999999 to +999999</td> <td>0 to +999999</td> </tr> </tbody> </table>	Setting value	Feed length multiplication (STM) [Multiplier]	Feed unit [μ m]	Position data input range [mm]		Absolute value command method	Incremental value command method	0	1	1	-999.999 to +999.999	0 to +999.999	1	10	10	-9999.99 to +9999.99	0 to +9999.99	2	100	100	-99999.9 to +99999.9	0 to +99999.9	3	1000	1000	-999999 to +999999	0 to +999999	0000h	PT03	<p>Feed function selection</p> <p>___ x:</p> <p>Feed length multiplication [STM]</p> <p>0: 1 multiplier 1: 10 multiplier 2: 100 multiplier 3: 1000 multiplier</p>	0h	CP
	Setting value				Feed length multiplication (STM) [Multiplier]	Feed unit [μ m]	Position data input range [mm]																										
		Absolute value command method	Incremental value command method																														
	0	1	1	-999.999 to +999.999	0 to +999.999																												
1	10	10	-9999.99 to +9999.99	0 to +9999.99																													
2	100	100	-99999.9 to +99999.9	0 to +99999.9																													
3	1000	1000	-999999 to +999999	0 to +999999																													
<p>0 _ x _:</p> <p>Manual pulse generator multiplication</p> <p>0: 1 multiplier 1: 10 multiplier 2: 100 multiplier</p>	<p>__ x _:</p> <p>For manufacturer setting</p>	0h																															
<p>0 x _ _:</p> <p>Servo motor speed setting unit selection</p> <p>0: 1 r/min unit 1: 0.1 r/min unit</p> <p>When set to "1", "Servo motor speed" in the status display is in units of 0.1 r/min.</p>	<p>_ x _ _:</p> <p>For manufacturer setting (no corresponding parameter)</p>	0h																															
	<p>x _ _ _:</p> <p>For manufacturer setting (no corresponding parameter)</p>	0h																															

Part 7: Review on Replacement of MR-J3-_T_ (CC-Link communication operation) with MR-J4-_GF_

MR-J3-_T_			MR-J4-_GF_			
No.	Name and function	Initial value	No.	Name and function	Initial value	Control mode
PA06 PA07	<p>Electronic gear numerator (command input pulse multiplication numerator)</p> <p>Electronic gear denominator (command input pulse multiplication denominator)</p> <p>The range of electronic gear setting is $\frac{1}{10} < \frac{CMX}{CDV} < 2000$. Setting any value out of the setting range will trigger [AL. 37 Parameter error].</p> <p>When [Pr. PA06] is set to "0", the servo motor detector resolution is set for the electronic gear numerator.</p> <p>(1) Logic of electronic gear</p> <p>An electronic gear ([Pr. PA06]/[Pr. PA07]) is used to adjust the servo amplifier setting values so that they match the travel distance of the machine.</p> <p>Also, by changing the electronic gear, the machine can be moved at any magnification with respect to the travel distance on the servo amplifier.</p> $\frac{CMX}{CDV} = \frac{[Pr. PA06]}{[Pr. PA07]}$	1 1	PA06 PA07	<p>Electronic gear numerator</p> <p>Electronic gear denominator</p> <p>Pt: Servo motor encoder resolution 4194304 [pulse/rev]</p> <p>ΔS: Travel distance per servo motor revolution [mm/rev]/[inch/rev]/[pulse/rev]</p> $CMX/CDV = Pt/\Delta S$ <p>Set the electronic gear within the following range of conditions.</p> <p>If a value out of the range is set, [AL. 37 Parameter error] occurs.</p> $1/865 < CMX/CDV < 271471$ <p>Setting range: 1 to 16777215</p>	1 1	CP
PA06 PA07	<p>Number of gear teeth on machine side</p> <p>Number of gear teeth on servo motor side</p> <ul style="list-style-type: none"> Set the electronic gear within the following range of conditions. <p>(1) $1/9999 \leq CMX/CDV \leq 9999$</p> <p>(2) $CDV \times STN \leq 32767$</p> <p>(3) $CMX \times CDV \leq 100000$</p> <p>Setting any value out of the range of conditions will trigger [AL. 37 Parameter error]. If a small value is set for the electronic gear ratio, the servo motor may not be driven at the set servo motor speed in the manual operation mode.</p> <ul style="list-style-type: none"> The setting range of [Pr. PA06] and [Pr. PA07] in the indexer positioning operation is 1 to 16384. The setting range is different from the setting range in the point table positioning operation. 	0000h	PA06 PA07	<p>Number of gear teeth on machine side</p> <p>Number of gear teeth on servo motor side</p> <p>When the number of pulley teeth on the machine side is 50 and the number of pulley teeth on the servo motor side is 20</p> <p>Set [Pr. PA06] = 50 and [Pr. PA07] = 20.</p> <p>Set the electronic gear within the following range of conditions.</p> <p>If a value out of the range is set, [AL. 37 Parameter error] occurs.</p> <ul style="list-style-type: none"> $1 \leq CMX \leq 16384, 1 \leq CDV \leq 16384$ $\frac{1}{9999} \leq \frac{CMX}{CDV} \leq 9999$ $CDV \times STN \times 32767$ (STN: Number of stations per rotation [Pr. PT28]) $CMX \times CDV \leq 100000$ <p>If a small value is set for the electronic gear ratio in the manual operation mode, the servo motor may not be driven at the set servo motor speed.</p> <p>1 station travel distance =</p> $Pt \text{ (servo motor resolution)} \times \frac{1}{STN} \times \frac{CMX}{CDV}$ <p>Setting range: 1 to 16777215</p>	1 1	PS

Part 7: Review on Replacement of MR-J3-_T_ (CC-Link communication operation) with MR-J4-_GF_

MR-J3-_T_			MR-J4-_GF_			Control mode																																																																											
No.	Name and function	Initial value	No.	Name and function	Initial value																																																																												
PA08	Auto tuning mode Use auto-tuning to adjust the gain. Select the gain adjustment mode. 0 0 0 x: Gain adjustment mode setting 0: Interpolation mode (Automatically set parameter No. [Pr. PB06]/[Pr. PB08]/[Pr. PB09]/[Pr. PB10]) 1: Auto tuning mode 1 (Automatically set parameter No. [Pr. PB06]/[Pr. PB07]/[Pr. PB08]/[Pr. PB09]/[Pr. PB10]) 2: Auto tuning mode 2 (Automatically set parameter No. [Pr. PB07]/[Pr. PB08]/[Pr. PB09]/[Pr. PB10]) The name of each parameter is as follows.	0001h	PA08	Auto tuning mode ___ x: Gain adjustment mode selection Select the gain adjustment mode. 0: 2 gain adjustment mode 1 (interpolation mode) 1: Auto tuning mode 1 2: Auto tuning mode 2 3: Manual mode 4: 2 gain adjustment mode 2 Refer to the following table for details.	1h	CP PS SP																																																																											
							___ x _:	0h																																																																									
							_ x _ _:	0h																																																																									
							x _ _ _:	0h																																																																									
			Gain adjustment mode selection																																																																														
			<table border="1"> <thead> <tr> <th>Setting value</th> <th>Gain adjustment mode</th> <th>Parameter adjusted automatically</th> </tr> </thead> <tbody> <tr> <td>___ 0</td> <td>2 gain adjustment mode 1 (Interpolation mode)</td> <td>[Pr. PB06 Load to motor inertia ratio] [Pr. PB08 Position control gain] [Pr. PB09 Speed control gain] [Pr. PB10 Speed integral compensation]</td> </tr> <tr> <td>___ 1</td> <td>Auto tuning Mode 1</td> <td>[Pr. PB06 Load to motor inertia ratio] [Pr. PB07 Model control gain] [Pr. PB08 Position control gain] [Pr. PB09 Speed control gain] [Pr. PB10 Speed integral compensation]</td> </tr> <tr> <td>___ 2</td> <td>Auto tuning Mode 2</td> <td>[Pr. PB07 Model control gain] [Pr. PB08 Position control gain] [Pr. PB09 Speed control gain] [Pr. PB10 Speed integral compensation]</td> </tr> <tr> <td>___ 3</td> <td>Manual mode</td> <td></td> </tr> <tr> <td>___ 4</td> <td>2 gain adjustment mode 2</td> <td>[Pr. PB08 Position control gain] [Pr. PB09 Speed control gain] [Pr. PB10 Speed integral compensation]</td> </tr> </tbody> </table>				Setting value	Gain adjustment mode	Parameter adjusted automatically	___ 0	2 gain adjustment mode 1 (Interpolation mode)	[Pr. PB06 Load to motor inertia ratio] [Pr. PB08 Position control gain] [Pr. PB09 Speed control gain] [Pr. PB10 Speed integral compensation]	___ 1	Auto tuning Mode 1	[Pr. PB06 Load to motor inertia ratio] [Pr. PB07 Model control gain] [Pr. PB08 Position control gain] [Pr. PB09 Speed control gain] [Pr. PB10 Speed integral compensation]	___ 2	Auto tuning Mode 2	[Pr. PB07 Model control gain] [Pr. PB08 Position control gain] [Pr. PB09 Speed control gain] [Pr. PB10 Speed integral compensation]	___ 3	Manual mode		___ 4	2 gain adjustment mode 2	[Pr. PB08 Position control gain] [Pr. PB09 Speed control gain] [Pr. PB10 Speed integral compensation]																																																									
Setting value	Gain adjustment mode	Parameter adjusted automatically																																																																															
___ 0	2 gain adjustment mode 1 (Interpolation mode)	[Pr. PB06 Load to motor inertia ratio] [Pr. PB08 Position control gain] [Pr. PB09 Speed control gain] [Pr. PB10 Speed integral compensation]																																																																															
___ 1	Auto tuning Mode 1	[Pr. PB06 Load to motor inertia ratio] [Pr. PB07 Model control gain] [Pr. PB08 Position control gain] [Pr. PB09 Speed control gain] [Pr. PB10 Speed integral compensation]																																																																															
___ 2	Auto tuning Mode 2	[Pr. PB07 Model control gain] [Pr. PB08 Position control gain] [Pr. PB09 Speed control gain] [Pr. PB10 Speed integral compensation]																																																																															
___ 3	Manual mode																																																																																
___ 4	2 gain adjustment mode 2	[Pr. PB08 Position control gain] [Pr. PB09 Speed control gain] [Pr. PB10 Speed integral compensation]																																																																															
PA09	Auto tuning response If hunting occurs in the machine or if the gear noise is loud, reduce the setting value. If wanting to shorten the stop setting time or improve other performances, increase the setting value.	12	PA09	Auto tuning response Set the auto tuning response.	16	CP PS SP																																																																											
							<table border="1"> <thead> <tr> <th rowspan="2">Setting value</th> <th colspan="2">Machine characteristic</th> <th rowspan="2">Setting value</th> <th colspan="2">Machine characteristic</th> </tr> <tr> <th>Responsiveness</th> <th>Guideline for machine resonance frequency [Hz]</th> <th>Responsiveness</th> <th>Guideline for machine resonance frequency [Hz]</th> </tr> </thead> <tbody> <tr> <td>1</td> <td rowspan="16">Low response ↑</td> <td>10.0</td> <td>17</td> <td rowspan="16">Medium response ↑</td> <td>67.1</td> </tr> <tr> <td>2</td> <td>11.3</td> <td>18</td> <td>75.6</td> </tr> <tr> <td>3</td> <td>12.7</td> <td>19</td> <td>85.2</td> </tr> <tr> <td>4</td> <td>14.3</td> <td>20</td> <td>95.9</td> </tr> <tr> <td>5</td> <td>16.1</td> <td>21</td> <td>108.0</td> </tr> <tr> <td>6</td> <td>18.1</td> <td>22</td> <td>121.7</td> </tr> <tr> <td>7</td> <td>20.4</td> <td>23</td> <td>137.1</td> </tr> <tr> <td>8</td> <td>23.0</td> <td>24</td> <td>154.4</td> </tr> <tr> <td>9</td> <td>25.9</td> <td>25</td> <td>173.9</td> </tr> <tr> <td>10</td> <td>29.2</td> <td>26</td> <td>195.9</td> </tr> <tr> <td>11</td> <td>32.9</td> <td>27</td> <td>220.6</td> </tr> <tr> <td>12</td> <td>37.0</td> <td>28</td> <td>248.5</td> </tr> <tr> <td>13</td> <td>41.7</td> <td>29</td> <td>279.9</td> </tr> <tr> <td>14</td> <td>47.0</td> <td>30</td> <td>315.3</td> </tr> <tr> <td>15</td> <td>52.9</td> <td>31</td> <td>355.1</td> </tr> <tr> <td>16</td> <td>Medium response ↓</td> <td>59.6</td> <td>32</td> <td>High response ↓</td> <td>400.0</td> </tr> </tbody> </table>				Setting value	Machine characteristic		Setting value	Machine characteristic		Responsiveness	Guideline for machine resonance frequency [Hz]	Responsiveness	Guideline for machine resonance frequency [Hz]	1	Low response ↑	10.0	17	Medium response ↑	67.1	2	11.3	18	75.6	3	12.7	19	85.2	4	14.3	20	95.9	5	16.1	21	108.0	6	18.1	22	121.7	7	20.4	23	137.1	8	23.0	24	154.4	9	25.9	25	173.9	10	29.2	26	195.9	11	32.9	27	220.6	12	37.0	28	248.5	13	41.7	29	279.9	14	47.0	30	315.3	15	52.9	31
Setting value	Machine characteristic		Setting value	Machine characteristic																																																																													
	Responsiveness	Guideline for machine resonance frequency [Hz]		Responsiveness	Guideline for machine resonance frequency [Hz]																																																																												
1	Low response ↑	10.0	17	Medium response ↑	67.1																																																																												
2		11.3	18		75.6																																																																												
3		12.7	19		85.2																																																																												
4		14.3	20		95.9																																																																												
5		16.1	21		108.0																																																																												
6		18.1	22		121.7																																																																												
7		20.4	23		137.1																																																																												
8		23.0	24		154.4																																																																												
9		25.9	25		173.9																																																																												
10		29.2	26		195.9																																																																												
11		32.9	27		220.6																																																																												
12		37.0	28		248.5																																																																												
13		41.7	29		279.9																																																																												
14		47.0	30		315.3																																																																												
15		52.9	31		355.1																																																																												
16		Medium response ↓	59.6		32	High response ↓	400.0																																																																										
			Setting range: 1 to 40																																																																														

Part 7: Review on Replacement of MR-J3-_T_ (CC-Link communication operation) with MR-J4-_GF_

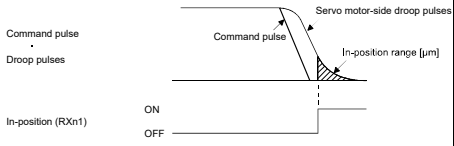
MR-J3-_T_			MR-J4-_GF_			
No.	Name and function	Initial value	No.	Name and function	Initial value	Control mode
PA10	<p>In-position range</p> <p>Set the range for outputting travel completion (RXnC) and in-position (RXn1) in units of command pulses before calculating the electronic gear. It can be changed to be in units of detector output pulses by setting [Pr. PC24]. The setting unit changes to pulse when the detector output pulse unit is used.</p>  <p>Command pulse Droop pulses In-position (RXn1) ON OFF</p>	100	PA10	<p>In-position range</p> <p>Set the in-position range in the command pulse unit. It can be changed to be in units of servo motor encoder pulse by setting [Pr. PC06].</p> <p>In I/O mode, the in-position range is the range in which RXnC (travel completion) and RXn1 (in-position) are output.</p> <p>The unit is as follows depending on the positioning mode.</p> <ul style="list-style-type: none"> For the point table method The unit is [μm]. For the indexer method The unit is command unit [pulse]. (A unit that expresses one rotation on the machine side by the number of servo motor resolution pulses) <p>For example, to set ±1 degree as the in-position range for the rotation angle at the machine end, set $4194304 \times (1/360) = 11650$ pulses.</p> <p>Setting range: 0 to 65535</p>	1600	CP PS
PA11 PA12	<p>Forward rotation torque limit</p> <p>Reverse rotation torque limit</p> <p>The torque generated by the servo motor can be limited.</p> <p>When torque is outputted with the analog monitor output, the torque of the larger value of either [Pr. PA11] (Forward rotation torque limit) or [Pr. PA12] (Reverse rotation torque limit value) becomes the maximum output voltage (8 V).</p> <p>Forward rotation torque limit [Pr. PA11] Set the maximum torque at 100 [%]. Set the servo parameter to limit the torque of the servo motor for CCW power running or CW regeneration. If this object is set to "0.0", the servo motor does not generate torque.</p> <p>Reverse rotation torque limit [Pr. PA12] Set the maximum torque at 100 [%]. Set the servo parameter to limit the torque of the servo motor for CW power running or CCW regeneration. If this object is set to "0.0", the servo motor does not generate torque.</p>	100.0 100.0	PA11 PA12	<p>Forward rotation torque limit</p> <p>The torque generated by the servo motor can be limited.</p> <p>Set the rated torque at 100.0 [%]. Set the servo parameter to limit the torque of the servo motor for CCW power running or CW regeneration. If this object is set to "0.0", the servo motor does not generate torque.</p> <p>The polarity of the torque limit can be changed with the setting values of [Pr. PA14 Rotation direction selection] and [Pr. PC29 POL reflection selection at torque mode].</p> <p>Setting range: 0.0 to 1000.0</p> <p>The torque generated by the servo motor can be limited.</p> <p>Set the rated torque at 100.0 [%]. Set the servo parameter to limit the torque of the servo motor for CW power running or CCW regeneration. If this object is set to "0.0", the servo motor does not generate torque.</p> <p>The polarity of the torque limit can be changed with the setting values of [Pr. PA14 Rotation direction selection/travel direction selection] and [Pr. PC29 POL reflection selection at torque mode].</p> <p>Setting range: 0.0 to 1000.0</p>	1000.0 1000.0	CP PS SP CP PS SP

Part 7: Review on Replacement of MR-J3-_T_ (CC-Link communication operation) with MR-J4-_GF_

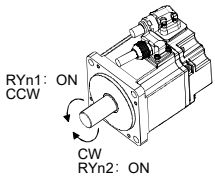
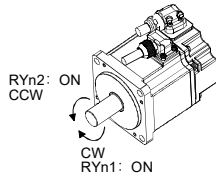
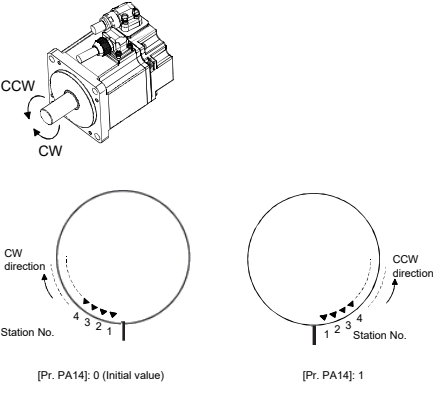
MR-J3-_T_			MR-J4-_GF_																								
No.	Name and function	Initial value	No.	Name and function	Initial value	Control mode																					
PA14	<p>Rotation direction selection Select the rotation direction of the servo motor when Forward rotation start (RYn1) or Reverse rotation start (RYn2) is turned on.</p> <table border="1"> <thead> <tr> <th rowspan="2">Setting value of [Pr. PA14]</th> <th colspan="2">Servo motor rotation direction</th> </tr> <tr> <th>Forward rotation start (RYn1) ON</th> <th>Reverse rotation start (RYn2) ON</th> </tr> </thead> <tbody> <tr> <td>0</td> <td>Rotate in CCW direction (address increasing)</td> <td>Rotate in CW direction (address decreasing)</td> </tr> <tr> <td>1</td> <td>Rotate in CW direction (address increasing)</td> <td>Rotate in CCW direction (address decreasing)</td> </tr> </tbody> </table> 	Setting value of [Pr. PA14]	Servo motor rotation direction		Forward rotation start (RYn1) ON	Reverse rotation start (RYn2) ON	0	Rotate in CCW direction (address increasing)	Rotate in CW direction (address decreasing)	1	Rotate in CW direction (address increasing)	Rotate in CCW direction (address decreasing)	0	<p>PA14</p> <p>Rotation direction selection Select the rotation direction of the servo motor when RYn1 (Forward rotation start) or RYn2 (Reverse rotation start) is turned on. The torque polarity can be changed with the combination of this parameter and [Pr. PC29 Torque POL reflection selection].</p> <table border="1"> <thead> <tr> <th rowspan="2">[Pr. PA14] setting value</th> <th colspan="2">Servo motor rotation direction</th> </tr> <tr> <th>With an increasing positioning address</th> <th>With a decreasing positioning address</th> </tr> </thead> <tbody> <tr> <td>0</td> <td>Rotate in CCW direction</td> <td>Rotate in CW direction</td> </tr> <tr> <td>1</td> <td>Rotate in CW direction</td> <td>Rotate in CCW direction</td> </tr> </tbody> </table> <p>The servo motor rotation direction is as follows.</p> 	[Pr. PA14] setting value	Servo motor rotation direction		With an increasing positioning address	With a decreasing positioning address	0	Rotate in CCW direction	Rotate in CW direction	1	Rotate in CW direction	Rotate in CCW direction	0	CP SP
Setting value of [Pr. PA14]	Servo motor rotation direction																										
	Forward rotation start (RYn1) ON	Reverse rotation start (RYn2) ON																									
0	Rotate in CCW direction (address increasing)	Rotate in CW direction (address decreasing)																									
1	Rotate in CW direction (address increasing)	Rotate in CCW direction (address decreasing)																									
[Pr. PA14] setting value	Servo motor rotation direction																										
	With an increasing positioning address	With a decreasing positioning address																									
0	Rotate in CCW direction	Rotate in CW direction																									
1	Rotate in CW direction	Rotate in CCW direction																									
PA14	<p>Station No. direction selection This parameter is enabled when the power is turned off and turned on again after setting. Select the station number assignment direction with this parameter.</p> <table border="1"> <thead> <tr> <th>[Pr. PA14] setting value</th> <th>Servo motor rotation direction Start (RYn1) ON</th> </tr> </thead> <tbody> <tr> <td>0</td> <td>Station numbers are assigned in the order of 1, 2, 3... in the CW direction.</td> </tr> <tr> <td>1</td> <td>Station numbers are assigned in the order of 1, 2, 3... in the CCW direction.</td> </tr> </tbody> </table> 	[Pr. PA14] setting value	Servo motor rotation direction Start (RYn1) ON	0	Station numbers are assigned in the order of 1, 2, 3... in the CW direction.	1	Station numbers are assigned in the order of 1, 2, 3... in the CCW direction.	0	<p>PA14</p> <p>Station No. direction selection Select the station number assignment direction.</p> <table border="1"> <thead> <tr> <th>Setting value of [Pr. PA14]</th> <th>Servo motor rotation direction RYn1 (start) ON</th> </tr> </thead> <tbody> <tr> <td>0</td> <td>Station numbers are assigned in the order of 1, 2, 3... in the CW direction.</td> </tr> <tr> <td>1</td> <td>Station numbers are assigned in the order of 1, 2, 3... in the CCW direction.</td> </tr> </tbody> </table> <p>Setting range: 0, 1</p>	Setting value of [Pr. PA14]	Servo motor rotation direction RYn1 (start) ON	0	Station numbers are assigned in the order of 1, 2, 3... in the CW direction.	1	Station numbers are assigned in the order of 1, 2, 3... in the CCW direction.	0	PS										
[Pr. PA14] setting value	Servo motor rotation direction Start (RYn1) ON																										
0	Station numbers are assigned in the order of 1, 2, 3... in the CW direction.																										
1	Station numbers are assigned in the order of 1, 2, 3... in the CCW direction.																										
Setting value of [Pr. PA14]	Servo motor rotation direction RYn1 (start) ON																										
0	Station numbers are assigned in the order of 1, 2, 3... in the CW direction.																										
1	Station numbers are assigned in the order of 1, 2, 3... in the CCW direction.																										

Part 7: Review on Replacement of MR-J3-_T_ (CC-Link communication operation) with MR-J4-_GF_

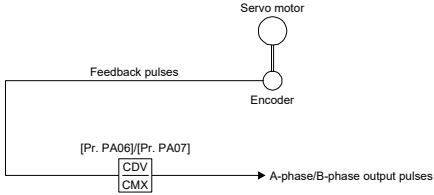
MR-J3-_T_			MR-J4-_GF_			
No.	Name and function	Initial value	No.	Name and function	Initial value	Control mode
PA15	<p>Detector output pulse</p> <p>Set the detector pulse (A-phase/B-phase) to be output by the servo amplifier. Set the value that is four times that of the A-phase/B-phase pulse. The output pulse setting or output dividing ratio setting can be selected in [Pr. PC19].</p> <p>The number of A-phase/B-phase pulses to be actually output is 1/4 times the set number of pulses. Also, the maximum output frequency is 4.6 Mpulses/s (after multiplication by 4). Use the value within the range.</p> <p>(1) When output pulse is specified Set [Pr. PC19] to " _ _ 0 _ ". Set the number of pulses per revolution of the servo motor. Output pulse = setting value [pulse/rev] For example, if [Pr. PA15] is set to "5600", the A-phase/B-phase pulses to be actually output will be as follows.</p> $\text{A-B-phase output pulses} = \frac{5600}{4} = 1400 \text{ [pulse]}$ <p>(2) When setting the output dividing ratio Set [Pr. PC19] to " _ _ 1 _ ". The number of pulses per revolution of the servo motor is divided by the set value.</p> $\text{Output pulse} = \frac{\text{Resolution per servo motor revolution}}{\text{Set value}} \text{ [pulses/rev]}$ <p>For example, if [Pr. PA15] is set to "8", the A-phase/B-phase pulses to be actually output will be as follows.</p> $\text{A/B-phase output pulses} = \frac{262144}{8} \cdot \frac{1}{4} = 8192 \text{ [pulse]}$ <p>(3) When outputting a pulse train similar to the command pulse Set [Pr. PC19] to " _ _ 2 _ ". The feedback pulses from the servo motor detector are processed and outputted as follows. Feedback pulses can be outputted in the same pulse unit as the command pulse.</p> 	4000	PA15	<p>Encoder output pulses</p> <p>Set the encoder output pulses outputted from the servo amplifier, by using the number of output pulses per revolution, dividing ratio, or electronic gear ratio. (after multiplication by 4)</p> <p>Set a numerator for the electronic gear for the A/B-phase pulse output when "A-phase/B-phase pulse electronic gear setting (_ _ 3 _)" is selected for "Encoder output pulse setting selection" of [Pr. PC03].</p> <p>The maximum output frequency is 4.6 Mpulses/s. Set the value within the range.</p> <p>Setting range: 1 to 4194304</p>	4000	CP PS SP

Part 7: Review on Replacement of MR-J3-_T_ (CC-Link communication operation) with MR-J4-_GF_

MR-J3-_T_			MR-J4-_GF_				Control mode																																																																																																																																																																																																																																																																																																																																			
No.	Name and function	Initial value	No.	Name and function	Initial value																																																																																																																																																																																																																																																																																																																																					
PA19	<p>Parameter writing prohibited</p> <p>In the factory setting, the basic setting parameters, gain/filter parameters, and extended setting parameters of this servo amplifier can be changed. Writing can be prohibited to prevent inadvertent changes by setting [Pr. PA19].</p> <p>The table below shows the parameters that are enabled for reference and writing according to the settings of [Pr. PA19]. ○Parameters that can be operated are marked with the ○ symbol.</p> <table border="1" data-bbox="248 595 660 887"> <thead> <tr> <th>PA19</th> <th>Setting value operation</th> <th>PA</th> <th>PB</th> <th>PC</th> <th>PD</th> </tr> </thead> <tbody> <tr> <td rowspan="2">0000h</td> <td>Reference</td> <td>○</td> <td>/</td> <td>/</td> <td>/</td> </tr> <tr> <td>Writable</td> <td>○</td> <td>/</td> <td>/</td> <td>/</td> </tr> <tr> <td rowspan="2">000Bh</td> <td>Reference</td> <td>○</td> <td>○</td> <td>○</td> <td>/</td> </tr> <tr> <td>Writable</td> <td>○</td> <td>○</td> <td>○</td> <td>/</td> </tr> <tr> <td rowspan="2">000Ch (initial value)</td> <td>Reference</td> <td>○</td> <td>○</td> <td>○</td> <td>○</td> </tr> <tr> <td>Writable</td> <td>○</td> <td>○</td> <td>○</td> <td>○</td> </tr> <tr> <td rowspan="2">100Bh</td> <td>Reference</td> <td>○</td> <td>/</td> <td>/</td> <td>/</td> </tr> <tr> <td>Writable</td> <td>19 only</td> <td>/</td> <td>/</td> <td>/</td> </tr> <tr> <td rowspan="2">100Ch</td> <td>Reference</td> <td>○</td> <td>○</td> <td>○</td> <td>○</td> </tr> <tr> <td>Writable</td> <td>19 only</td> <td>/</td> <td>/</td> <td>/</td> </tr> </tbody> </table>	PA19	Setting value operation	PA	PB	PC	PD	0000h	Reference	○	/	/	/	Writable	○	/	/	/	000Bh	Reference	○	○	○	/	Writable	○	○	○	/	000Ch (initial value)	Reference	○	○	○	○	Writable	○	○	○	○	100Bh	Reference	○	/	/	/	Writable	19 only	/	/	/	100Ch	Reference	○	○	○	○	Writable	19 only	/	/	/	000Ch	PA19	<p>Parameter writing prohibited</p> <p>Select a reference range and writing range for the parameter.</p> <p>In I/O mode, set [Pr. PA19] to "0 0 A B" to enable reading and writing of positioning control parameters ([Pr. PT_ _]) and network setting parameters ([Pr. PN_ _]).</p> <p>Refer to the following table for setting values.</p> <p>Setting value and read/write range of [Pr. PA19]</p> <table border="1" data-bbox="842 577 1436 1411"> <thead> <tr> <th>PA19</th> <th>Setting value operation</th> <th>PA</th> <th>PB</th> <th>PC</th> <th>PD</th> <th>PE</th> <th>PF</th> <th>PL</th> <th>PT</th> <th>PN</th> </tr> </thead> <tbody> <tr> <td rowspan="2">Setting values not listed below</td> <td>Readable</td> <td>○</td> <td>/</td> <td>/</td> <td>/</td> <td>/</td> <td>/</td> <td>/</td> <td>/</td> <td>/</td> </tr> <tr> <td>Writable</td> <td>○</td> <td>/</td> <td>/</td> <td>/</td> <td>/</td> <td>/</td> <td>/</td> <td>/</td> <td>/</td> </tr> <tr> <td rowspan="2">000Ah</td> <td>Readable</td> <td>19 only</td> <td>/</td> <td>/</td> <td>/</td> <td>/</td> <td>/</td> <td>/</td> <td>/</td> <td>/</td> </tr> <tr> <td>Writable</td> <td>19 only</td> <td>/</td> <td>/</td> <td>/</td> <td>/</td> <td>/</td> <td>/</td> <td>/</td> <td>/</td> </tr> <tr> <td rowspan="2">000Bh</td> <td>Readable</td> <td>○</td> <td>○</td> <td>○</td> <td>/</td> <td>/</td> <td>/</td> <td>/</td> <td>/</td> <td>/</td> </tr> <tr> <td>Writable</td> <td>○</td> <td>○</td> <td>○</td> <td>/</td> <td>/</td> <td>/</td> <td>/</td> <td>/</td> <td>/</td> </tr> <tr> <td rowspan="2">000Ch</td> <td>Readable</td> <td>○</td> <td>○</td> <td>○</td> <td>○</td> <td>/</td> <td>/</td> <td>/</td> <td>/</td> <td>/</td> </tr> <tr> <td>Writable</td> <td>○</td> <td>○</td> <td>○</td> <td>○</td> <td>/</td> <td>/</td> <td>/</td> <td>/</td> <td>/</td> </tr> <tr> <td rowspan="2">000Fh</td> <td>Readable</td> <td>○</td> <td>○</td> <td>○</td> <td>○</td> <td>○</td> <td>/</td> <td>○</td> <td>/</td> <td>/</td> </tr> <tr> <td>Writable</td> <td>○</td> <td>○</td> <td>○</td> <td>○</td> <td>○</td> <td>/</td> <td>○</td> <td>/</td> <td>/</td> </tr> <tr> <td rowspan="2">00AAh</td> <td>Readable</td> <td>○</td> <td>○</td> <td>○</td> <td>○</td> <td>○</td> <td>○</td> <td>/</td> <td>/</td> <td>/</td> </tr> <tr> <td>Writable</td> <td>○</td> <td>○</td> <td>○</td> <td>○</td> <td>○</td> <td>○</td> <td>/</td> <td>/</td> <td>/</td> </tr> <tr> <td rowspan="2">00ABh (initial value)</td> <td>Readable</td> <td>○</td> <td>○</td> <td>○</td> <td>○</td> <td>○</td> <td>○</td> <td>○</td> <td>○</td> <td>○</td> </tr> <tr> <td>Writable</td> <td>○</td> <td>○</td> <td>○</td> <td>○</td> <td>○</td> <td>○</td> <td>○</td> <td>○</td> <td>○</td> </tr> <tr> <td rowspan="2">100Bh</td> <td>Readable</td> <td>○</td> <td>/</td> <td>/</td> <td>/</td> <td>/</td> <td>/</td> <td>/</td> <td>/</td> <td>/</td> </tr> <tr> <td>Writable</td> <td>19 only</td> <td>/</td> <td>/</td> <td>/</td> <td>/</td> <td>/</td> <td>/</td> <td>/</td> <td>/</td> </tr> <tr> <td rowspan="2">100Ch</td> <td>Readable</td> <td>○</td> <td>○</td> <td>○</td> <td>○</td> <td>/</td> <td>/</td> <td>/</td> <td>/</td> <td>/</td> </tr> <tr> <td>Writable</td> <td>19 only</td> <td>/</td> <td>/</td> <td>/</td> <td>/</td> <td>/</td> <td>/</td> <td>/</td> <td>/</td> </tr> <tr> <td rowspan="2">100Fh</td> <td>Readable</td> <td>○</td> <td>○</td> <td>○</td> <td>○</td> <td>○</td> <td>/</td> <td>○</td> <td>/</td> <td>/</td> </tr> <tr> <td>Writable</td> <td>19 only</td> <td>/</td> <td>/</td> <td>/</td> <td>/</td> <td>/</td> <td>/</td> <td>/</td> <td>/</td> </tr> <tr> <td rowspan="2">10AAh</td> <td>Readable</td> <td>○</td> <td>○</td> <td>○</td> <td>○</td> <td>○</td> <td>○</td> <td>/</td> <td>/</td> <td>/</td> </tr> <tr> <td>Writable</td> <td>19 only</td> <td>/</td> <td>/</td> <td>/</td> <td>/</td> <td>/</td> <td>/</td> <td>/</td> <td>/</td> </tr> <tr> <td rowspan="2">10ABh</td> <td>Readable</td> <td>○</td> <td>○</td> <td>○</td> <td>○</td> <td>○</td> <td>○</td> <td>○</td> <td>○</td> <td>○</td> </tr> <tr> <td>Writable</td> <td>19 only</td> <td>/</td> <td>/</td> <td>/</td> <td>/</td> <td>/</td> <td>/</td> <td>/</td> <td>/</td> </tr> </tbody> </table>	PA19	Setting value operation	PA	PB	PC	PD	PE	PF	PL	PT	PN	Setting values not listed below	Readable	○	/	/	/	/	/	/	/	/	Writable	○	/	/	/	/	/	/	/	/	000Ah	Readable	19 only	/	/	/	/	/	/	/	/	Writable	19 only	/	/	/	/	/	/	/	/	000Bh	Readable	○	○	○	/	/	/	/	/	/	Writable	○	○	○	/	/	/	/	/	/	000Ch	Readable	○	○	○	○	/	/	/	/	/	Writable	○	○	○	○	/	/	/	/	/	000Fh	Readable	○	○	○	○	○	/	○	/	/	Writable	○	○	○	○	○	/	○	/	/	00AAh	Readable	○	○	○	○	○	○	/	/	/	Writable	○	○	○	○	○	○	/	/	/	00ABh (initial value)	Readable	○	○	○	○	○	○	○	○	○	Writable	○	○	○	○	○	○	○	○	○	100Bh	Readable	○	/	/	/	/	/	/	/	/	Writable	19 only	/	/	/	/	/	/	/	/	100Ch	Readable	○	○	○	○	/	/	/	/	/	Writable	19 only	/	/	/	/	/	/	/	/	100Fh	Readable	○	○	○	○	○	/	○	/	/	Writable	19 only	/	/	/	/	/	/	/	/	10AAh	Readable	○	○	○	○	○	○	/	/	/	Writable	19 only	/	/	/	/	/	/	/	/	10ABh	Readable	○	○	○	○	○	○	○	○	○	Writable	19 only	/	/	/	/	/	/	/	/	00ABh	CP PS SP
PA19	Setting value operation	PA	PB	PC	PD																																																																																																																																																																																																																																																																																																																																					
0000h	Reference	○	/	/	/																																																																																																																																																																																																																																																																																																																																					
	Writable	○	/	/	/																																																																																																																																																																																																																																																																																																																																					
000Bh	Reference	○	○	○	/																																																																																																																																																																																																																																																																																																																																					
	Writable	○	○	○	/																																																																																																																																																																																																																																																																																																																																					
000Ch (initial value)	Reference	○	○	○	○																																																																																																																																																																																																																																																																																																																																					
	Writable	○	○	○	○																																																																																																																																																																																																																																																																																																																																					
100Bh	Reference	○	/	/	/																																																																																																																																																																																																																																																																																																																																					
	Writable	19 only	/	/	/																																																																																																																																																																																																																																																																																																																																					
100Ch	Reference	○	○	○	○																																																																																																																																																																																																																																																																																																																																					
	Writable	19 only	/	/	/																																																																																																																																																																																																																																																																																																																																					
PA19	Setting value operation	PA	PB	PC	PD	PE	PF	PL	PT	PN																																																																																																																																																																																																																																																																																																																																
Setting values not listed below	Readable	○	/	/	/	/	/	/	/	/																																																																																																																																																																																																																																																																																																																																
	Writable	○	/	/	/	/	/	/	/	/																																																																																																																																																																																																																																																																																																																																
000Ah	Readable	19 only	/	/	/	/	/	/	/	/																																																																																																																																																																																																																																																																																																																																
	Writable	19 only	/	/	/	/	/	/	/	/																																																																																																																																																																																																																																																																																																																																
000Bh	Readable	○	○	○	/	/	/	/	/	/																																																																																																																																																																																																																																																																																																																																
	Writable	○	○	○	/	/	/	/	/	/																																																																																																																																																																																																																																																																																																																																
000Ch	Readable	○	○	○	○	/	/	/	/	/																																																																																																																																																																																																																																																																																																																																
	Writable	○	○	○	○	/	/	/	/	/																																																																																																																																																																																																																																																																																																																																
000Fh	Readable	○	○	○	○	○	/	○	/	/																																																																																																																																																																																																																																																																																																																																
	Writable	○	○	○	○	○	/	○	/	/																																																																																																																																																																																																																																																																																																																																
00AAh	Readable	○	○	○	○	○	○	/	/	/																																																																																																																																																																																																																																																																																																																																
	Writable	○	○	○	○	○	○	/	/	/																																																																																																																																																																																																																																																																																																																																
00ABh (initial value)	Readable	○	○	○	○	○	○	○	○	○																																																																																																																																																																																																																																																																																																																																
	Writable	○	○	○	○	○	○	○	○	○																																																																																																																																																																																																																																																																																																																																
100Bh	Readable	○	/	/	/	/	/	/	/	/																																																																																																																																																																																																																																																																																																																																
	Writable	19 only	/	/	/	/	/	/	/	/																																																																																																																																																																																																																																																																																																																																
100Ch	Readable	○	○	○	○	/	/	/	/	/																																																																																																																																																																																																																																																																																																																																
	Writable	19 only	/	/	/	/	/	/	/	/																																																																																																																																																																																																																																																																																																																																
100Fh	Readable	○	○	○	○	○	/	○	/	/																																																																																																																																																																																																																																																																																																																																
	Writable	19 only	/	/	/	/	/	/	/	/																																																																																																																																																																																																																																																																																																																																
10AAh	Readable	○	○	○	○	○	○	/	/	/																																																																																																																																																																																																																																																																																																																																
	Writable	19 only	/	/	/	/	/	/	/	/																																																																																																																																																																																																																																																																																																																																
10ABh	Readable	○	○	○	○	○	○	○	○	○																																																																																																																																																																																																																																																																																																																																
	Writable	19 only	/	/	/	/	/	/	/	/																																																																																																																																																																																																																																																																																																																																

Part 7: Review on Replacement of MR-J3-_T_ (CC-Link communication operation) with MR-J4-_GF_

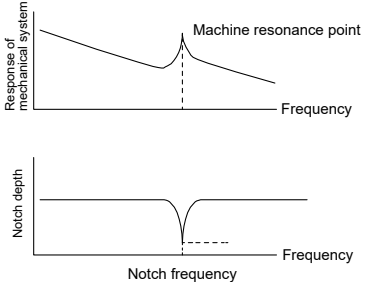
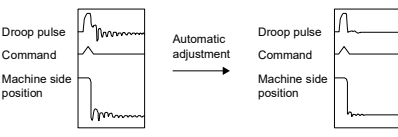
MR-J3-_T_			MR-J4-_GF_					
No.	Name and function	Initial value	No.	Name and function	Initial value	Control mode		
PB01	<p>Adaptive tuning mode (adaptive filter II) Select the method for setting adaptive tuning. When this parameter is set to "___ 1" (filter tuning mode), Mechanical resonance suppression filter 1 ([Pr. PB13]) and Notch shape selection 1 ([Pr. PB14]) are automatically changed.</p>  <p>0 0 0 x: Adaptive tuning mode selection 0: Filter OFF ([Pr. PB13]/[Pr. PB14] is fixed to the initial value.) 1: Filter tuning mode (automatically set parameter: [Pr. PB13]/[Pr. PB14]) 2: Manual mode</p> <p>When "___ 1" is set, tuning is completed after positioning operation is performed for a certain period of time and a certain number of times. The parameter then changes to "___ 2". If adaptive tuning is not required, the parameter will change to "___ 0". When "___ 0" is set, the initial value is set to Mechanical resonance suppression filter 1 and Notch shape selection 1. However, this operation is not performed in the servo-off state.</p>	0000h	<p>PB01 Adaptive tuning mode (adaptive filter II) Filter tuning mode selection Setting of the adaptive tuning is performed. Select the adjustment mode of the machine resonance suppression filter 1. For details, refer to "MR-J4-_GF_(-RJ) Servo Amplifier Instruction Manual (Motion Mode)". ___ x: 0: Disabled 1: Automatic setting 2: Manual setting</p>	0h	CP PS SP			
						___ x _:	0h	
						For manufacturer setting	0h	
						x ___:	0h	
PB02	<p>Vibration suppression control tuning mode (advanced vibration suppression control) Vibration suppression control is enabled when [Pr. PA08] (auto tuning mode) is "___ 2" or "___ 3". When [Pr. PA08] is "___ 1", vibration suppression control is always disabled. Select the method for setting vibration suppression control tuning. When this parameter is set to "___ 1" (vibration suppression control tuning mode), Vibration suppression control - Vibration frequency ([Pr. PB19]) and Vibration suppression control - Resonance frequency ([Pr. PB20]) are automatically changed after positioning operation is performed for a certain period of time.</p>  <p>0 0 0 x: Vibration suppression control tuning mode 0: Vibration suppression control OFF ([Pr. PB19]/[Pr. PB20]) is fixed to the initial value.) 1: Vibration suppression control tuning mode (advanced vibration suppression control) (Automatically set parameter [Pr. PB19]/[Pr. PB20]) 2: Manual mode</p> <p>When "___ 1" is set, tuning is completed after positioning operation is performed for a certain period of time and a certain number of times. The parameter then changes to "___ 2". If vibration suppression control tuning is not required, the parameter will change to "___ 0". When "___ 0" is set, the initial value is set to Vibration suppression control - Vibration frequency and Vibration suppression control - Resonance frequency. However, this operation is not performed in the servo-off state.</p>	0000h	<p>PB02 Vibration suppression control tuning mode (advanced vibration suppression control II) Vibration suppression control 1 - Tuning mode selection Select the tuning mode of the vibration suppression control 1. For details, refer to "MR-J4-_GF_(-RJ) Servo Amplifier Instruction Manual (Motion Mode)". ___ x: 0: Disabled 1: Automatic setting 2: Manual setting</p>	0h	CP PS			
						___ x _:	0h	CP PS
						Vibration suppression control 2 - Tuning mode selection Select the tuning mode of the vibration suppression control 2. If "3 inertia mode (___ 1)" is selected for "Vibration suppression mode selection" in [Pr. PA24], the setting value of this digit is enabled. For details, refer to "MR-J4-_GF_(-RJ) Servo Amplifier Instruction Manual (Motion Mode)". 0: Disabled 1: Automatic setting 2: Manual setting	0h	
						x ___:	0h	

Part 7: Review on Replacement of MR-J3-_T_ (CC-Link communication operation) with MR-J4-_GF_

MR-J3-_T_			MR-J4-_GF_			Control mode										
No.	Name and function	Initial value	No.	Name and function	Initial value											
PB04	<p>Feed forward gain Set the feed forward gain. When 100% is set, the droop pulses of when operating at a constant speed become almost zero. However, if sudden acceleration/deceleration is performed, overshoot becomes large. As a guide, when the feed forward gain is set to 100%, set a value not smaller than 1 s for the acceleration time constant until the rated speed is reached.</p>	0	PB04	<p>Feed forward gain Set the feed forward gain. When 100% is set and constant speed operation is performed, the droop pulses become almost zero. However, if sudden acceleration/deceleration is performed, overshoot becomes large. When the feed forward gain is set to 100%, set a value not smaller than 1 s for the acceleration time constant until the rated speed is reached.</p> <p>Setting range: 0 to 100</p>	0	CP PS										
PB06	<p>Load to motor inertia ratio Set the load to motor inertia ratio for the servo motor shaft inertia moment. When auto tuning mode 1 or interpolation mode is selected, the auto tuning result is automatically obtained. In this case, the value varies within the range of 0 to 100.00.</p>	7.0	PB06	<p>Load to motor inertia ratio Set the load to motor inertia ratio. Setting a value greatly different from the actual load moment of inertia may cause an unexpected operation such as an overshoot. This parameter will be automatic or manual depending on the setting value of [Pr. PA08]. Refer to the following table for details. When the parameter is set to automatic setting, the value varies within the range of 0.00 to 100.00.</p> <p>Setting range: 0.00 to 300.00</p> <table border="1" style="width: 100%; border-collapse: collapse;"> <thead> <tr> <th style="width: 60%;">Pr. PA08</th> <th style="width: 40%;">State of this parameter</th> </tr> </thead> <tbody> <tr> <td>___ 0 (2 gain adjustment mode 1 (interpolation mode))</td> <td rowspan="2">Automatic setting</td> </tr> <tr> <td>___ 1 (auto tuning mode 1)</td> </tr> <tr> <td>___ 2 (auto tuning mode 2)</td> <td rowspan="3">Manual setting</td> </tr> <tr> <td>___ 3 (manual mode)</td> </tr> <tr> <td>___ 4 (2 gain adjustment mode 2)</td> </tr> </tbody> </table>	Pr. PA08	State of this parameter	___ 0 (2 gain adjustment mode 1 (interpolation mode))	Automatic setting	___ 1 (auto tuning mode 1)	___ 2 (auto tuning mode 2)	Manual setting	___ 3 (manual mode)	___ 4 (2 gain adjustment mode 2)	7.00	CP PS SP	
Pr. PA08	State of this parameter															
___ 0 (2 gain adjustment mode 1 (interpolation mode))	Automatic setting															
___ 1 (auto tuning mode 1)																
___ 2 (auto tuning mode 2)	Manual setting															
___ 3 (manual mode)																
___ 4 (2 gain adjustment mode 2)																
PB07	<p>Model control gain Set the response gain to the target position. Increasing the gain improves trackability to a command. When auto tuning mode 1 or auto tuning mode 2 is set, the auto-tuning result is automatically obtained.</p>	24	PB07	<p>Model control gain Set the response gain to the target position. Increasing the setting value improves responsiveness to the position command, but increasing the value too much raises the likelihood of vibration and noise. When using vibration suppression control, the setting range of [Pr. PB07] is limited. For details, refer to "MR-J4-_GF_(-RJ) Servo Amplifier Instruction Manual (Motion Mode)". This parameter will be automatic or manual depending on the setting value of [Pr. PA08]. Refer to the following table for details.</p> <p>Setting range: 1.0 to 2000.0</p> <table border="1" style="width: 100%; border-collapse: collapse;"> <thead> <tr> <th style="width: 60%;">Pr. PA08</th> <th style="width: 40%;">State of this parameter</th> </tr> </thead> <tbody> <tr> <td>___ 0 (2 gain adjustment mode 1 (interpolation mode))</td> <td>Manual setting</td> </tr> <tr> <td>___ 1 (auto tuning mode 1)</td> <td rowspan="2">Automatic setting</td> </tr> <tr> <td>___ 2 (auto tuning mode 2)</td> </tr> <tr> <td>___ 3 (manual mode)</td> <td rowspan="2">Manual setting</td> </tr> <tr> <td>___ 4 (2 gain adjustment mode 2)</td> </tr> </tbody> </table>	Pr. PA08	State of this parameter	___ 0 (2 gain adjustment mode 1 (interpolation mode))	Manual setting	___ 1 (auto tuning mode 1)	Automatic setting	___ 2 (auto tuning mode 2)	___ 3 (manual mode)	Manual setting	___ 4 (2 gain adjustment mode 2)	15.0	CP PS
Pr. PA08	State of this parameter															
___ 0 (2 gain adjustment mode 1 (interpolation mode))	Manual setting															
___ 1 (auto tuning mode 1)	Automatic setting															
___ 2 (auto tuning mode 2)																
___ 3 (manual mode)	Manual setting															
___ 4 (2 gain adjustment mode 2)																

Part 7: Review on Replacement of MR-J3-_T_ (CC-Link communication operation) with MR-J4-_GF_

MR-J3-_T_			MR-J4-_GF_			Control mode										
No.	Name and function	Initial value	No.	Name and function	Initial value											
PB08	<p>Position control gain</p> <p>Set the gain of the position loop.</p> <p>Set this servo parameter when increasing the position responsiveness to level load disturbance. Increasing the setting value improves responsiveness, but raises the likelihood of vibration and noise.</p> <p>When auto tuning mode 1, auto tuning mode 2, or interpolation mode is set, the auto tuning result is automatically obtained.</p>	37	PB08	<p>Position control gain</p> <p>Set the gain of the position loop.</p> <p>Set this servo parameter when increasing the position responsiveness to level load disturbance. Increasing the setting value improves responsiveness to the load disturbance, but increasing the value too much raises the likelihood of vibration and noise.</p> <p>This parameter will be automatic or manual depending on the setting value of [Pr. PA08]. Refer to the following table for details.</p> <p>Setting range: 1.0 to 2000.0</p> <table border="1" data-bbox="858 674 1417 891"> <thead> <tr> <th>Pr. PA08</th> <th>State of this parameter</th> </tr> </thead> <tbody> <tr> <td>___ 0 (2 gain adjustment mode 1 (interpolation mode))</td> <td rowspan="3">Automatic setting</td> </tr> <tr> <td>___ 1 (auto tuning mode 1)</td> </tr> <tr> <td>___ 2 (auto tuning mode 2)</td> </tr> <tr> <td>___ 3 (manual mode)</td> <td>Manual setting</td> </tr> <tr> <td>___ 4 (2 gain adjustment mode 2)</td> <td>Automatic setting</td> </tr> </tbody> </table>	Pr. PA08	State of this parameter	___ 0 (2 gain adjustment mode 1 (interpolation mode))	Automatic setting	___ 1 (auto tuning mode 1)	___ 2 (auto tuning mode 2)	___ 3 (manual mode)	Manual setting	___ 4 (2 gain adjustment mode 2)	Automatic setting	37.0	CP PS
Pr. PA08	State of this parameter															
___ 0 (2 gain adjustment mode 1 (interpolation mode))	Automatic setting															
___ 1 (auto tuning mode 1)																
___ 2 (auto tuning mode 2)																
___ 3 (manual mode)	Manual setting															
___ 4 (2 gain adjustment mode 2)	Automatic setting															
PB09	<p>Speed control gain</p> <p>Set the gain of the speed loop.</p> <p>Set this servo parameter when vibration occurs on machines with low rigidity or with large backlash. Increasing the setting value improves responsiveness, but raises the likelihood of vibration and noise.</p> <p>When auto tuning mode 1, auto tuning mode 2, or interpolation mode is set, the auto tuning result is automatically obtained.</p>	823	PB09	<p>Speed control gain</p> <p>Set the gain of the speed loop.</p> <p>Set this servo parameter when vibration occurs on machines with low rigidity or with large backlash. Increasing the setting value improves responsiveness, but increasing the value too much raises the likelihood of vibration and noise.</p> <p>This parameter will be automatic or manual depending on the setting value of [Pr. PA08]. Refer to the [Pr. PB08] table above for details.</p> <p>Setting range: 20 to 65535</p>	823	CP PS SP										
PB10	<p>Speed integral compensation</p> <p>Set the integral time constant of the speed loop. Decreasing the setting value improves responsiveness, but raises the likelihood of vibration and noise.</p> <p>When auto tuning mode 1, auto tuning mode 2, or interpolation mode is set, the auto tuning result is automatically obtained.</p>	33.7	PB10	<p>Speed integral compensation</p> <p>Set the integral time constant of the speed loop. Decreasing the setting value improves responsiveness, but raises the likelihood of vibration and noise.</p> <p>This parameter will be automatic or manual depending on the setting value of [Pr. PA08]. Refer to the [Pr. PB08] table above for details.</p> <p>Setting range: 0.1 to 1000.0</p>	33.7	CP PS SP										
PB11	<p>Speed differential compensation</p> <p>Set the differential compensation.</p> <p>This parameter is enabled when proportional control (RY (n + 2) 7) is turned on.</p>	980	PB11	<p>Speed differential compensation</p> <p>Set the differential compensation.</p> <p>This parameter is always enabled when "Continuous PID control enabled (___ 3 ___)" is set to "PI-PID switching control selection" in [Pr. PB24].</p> <p>This parameter is enabled by turning on the PC (proportional control) or turning on the PID switching signal from the controller.</p> <p>Setting range: 0 to 1000</p>	980	CP PS SP										
PB12	<p>For manufacturer setting</p> <p>Never change this parameter.</p>	0	PB12	<p>Overshoot amount compensation</p> <p>Set a viscous friction torque in percentage to the rated torque at servo motor rated speed.</p> <p>If the responsiveness is too low or if the torque is limited, the efficiency of the parameter may decrease.</p> <p>Setting range: 0 to 100</p>	0	CP PS										

Part 7: Review on Replacement of MR-J3-_T_ (CC-Link communication operation) with MR-J4-_GF_

MR-J3-_T_			MR-J4-_GF_			Control mode																												
No.	Name and function	Initial value	No.	Name and function	Initial value																													
PB13	<p>Machine resonance suppression filter 1</p> <p>Set the notch frequency of the machine resonance suppression filter 1.</p> <p>If [Pr. PB01] (adaptive tuning mode) is set to "____1", this parameter is automatically changed.</p> <p>If [Pr. PB01] is "____0", the setting of this parameter is ignored.</p>	4500	PB13	<p>Machine resonance suppression filter 1</p> <p>Set the notch frequency of the machine resonance suppression filter 1.</p> <p>When "Automatic setting (____1)" is selected for "Filter tuning mode selection" in [Pr. PB01], the values obtained from adaptive tuning are applied.</p> <p>When "Manual setting (____2)" is selected for "Filter tuning mode selection" in [Pr. PB01], the setting value of this parameter is enabled.</p> <p>Setting range: 10 to 4500</p>	4500	CP PS SP																												
PB14	<p>Notch shape selection 1</p> <p>Select forms of the mechanical resonance suppression filter 1.</p> <p>0_x_0:</p> <p>Notch depth selection</p> <table border="1"> <thead> <tr> <th>Setting value</th> <th>Depth</th> <th>Gain</th> </tr> </thead> <tbody> <tr> <td>0</td> <td rowspan="2">Deep</td> <td>-40dB</td> </tr> <tr> <td>1</td> <td>-14dB</td> </tr> <tr> <td>2</td> <td>to</td> <td>-8dB</td> </tr> <tr> <td>3</td> <td>Shallow</td> <td>-4dB</td> </tr> </tbody> </table> <p>0_x_0:</p> <p>Notch width selection</p> <table border="1"> <thead> <tr> <th>Setting value</th> <th>Depth</th> <th>α</th> </tr> </thead> <tbody> <tr> <td>0</td> <td rowspan="2">Standard</td> <td>2</td> </tr> <tr> <td>1</td> <td>3</td> </tr> <tr> <td>2</td> <td>to</td> <td>4</td> </tr> <tr> <td>3</td> <td>Wide</td> <td>5</td> </tr> </tbody> </table> <p>If [Pr. PB01] (adaptive tuning mode) is set to "____1", this parameter is automatically changed.</p> <p>If [Pr. PB01] is "____0", the setting of this parameter is ignored.</p>	Setting value	Depth	Gain	0	Deep	-40dB	1	-14dB	2	to	-8dB	3	Shallow	-4dB	Setting value	Depth	α	0	Standard	2	1	3	2	to	4	3	Wide	5	0000h	PB14	<p>Notch shape selection 1</p> <p>Set forms of the machine resonance suppression filter 1.</p> <p>When "Automatic setting (____1)" is selected for "Filter tuning mode selection" in [Pr. PB01], the values obtained from adaptive tuning are applied.</p> <p>When "Manual setting (____2)" is selected for "Filter tuning mode selection" in [Pr. PB01], the setting value of this parameter is enabled.</p> <p>____x:</p> <p>For manufacturer setting</p>	0h	CP PS SP
Setting value	Depth	Gain																																
0	Deep	-40dB																																
1		-14dB																																
2	to	-8dB																																
3	Shallow	-4dB																																
Setting value	Depth	α																																
0	Standard	2																																
1		3																																
2	to	4																																
3	Wide	5																																
			<p>____x_:</p> <p>Notch depth selection</p> <p>0: -40 dB</p> <p>1: -14 dB</p> <p>2: -8 dB</p> <p>3: -4 dB</p>	0h	CP PS SP																													
			<p>__x__:</p> <p>Notch width selection</p> <p>0: $\alpha = 2$</p> <p>1: $\alpha = 3$</p> <p>2: $\alpha = 4$</p> <p>3: $\alpha = 5$</p>	0h	CP PS SP																													
			<p>x____:</p> <p>For manufacturer setting</p>	0h																														
PB15	<p>Machine resonance suppression filter 2</p> <p>Set the notch frequency of the machine resonance suppression filter 2.</p> <p>This parameter is enabled when [Pr. PB16] (Notch shape selection 2) is set to "____1".</p>	4500	PB15	<p>Machine resonance suppression filter 2</p> <p>Set the notch frequency of the machine resonance suppression filter 2.</p> <p>If "Enable (____1)" is selected for "Machine resonance suppression filter 2 selection" in [Pr. PB16], the setting value of this parameter is enabled.</p> <p>Setting range: 10 to 4500</p>	4500	CP PS SP																												

Part 7: Review on Replacement of MR-J3-_T_ (CC-Link communication operation) with MR-J4-_GF_

MR-J3-_T_			MR-J4-_GF_																																						
No.	Name and function	Initial value	No.	Name and function	Initial value	Control mode																																			
PB16	Notch shape selection 2 Select forms of the mechanical resonance suppression filter 2. 0 __ x: Mechanical resonance suppression filter 2 selection 0: Disabled 1: Enabled	0000h	PB16	Notch shape selection 2 Set forms of the machine resonance suppression filter 2. ____ x: Mechanical resonance suppression filter 2 selection 0: Disabled 1: Enabled	0h	CP PS SP																																			
	0 x _: Notch depth selection			__ x _: Notch depth selection 0: -40 dB 1: -14 dB 2: -8 dB 3: -4 dB			0h	CP PS SP																																	
	<table border="1"> <thead> <tr> <th>Setting value</th> <th>Depth</th> <th>Gain</th> </tr> </thead> <tbody> <tr> <td>0</td> <td>Deep</td> <td>-40dB</td> </tr> <tr> <td>1</td> <td>to</td> <td>-14dB</td> </tr> <tr> <td>2</td> <td></td> <td>-8dB</td> </tr> <tr> <td>3</td> <td>Shallow</td> <td>-4dB</td> </tr> </tbody> </table>			Setting value					Depth	Gain	0	Deep	-40dB	1	to	-14dB	2		-8dB	3	Shallow	-4dB	<table border="1"> <thead> <tr> <th>Setting value</th> <th>Depth</th> <th>α</th> </tr> </thead> <tbody> <tr> <td>0</td> <td>Standard</td> <td>2</td> </tr> <tr> <td>1</td> <td>to</td> <td>3</td> </tr> <tr> <td>2</td> <td></td> <td>4</td> </tr> <tr> <td>3</td> <td>Wide</td> <td>5</td> </tr> </tbody> </table>	Setting value	Depth	α	0	Standard	2	1	to	3	2		4	3	Wide	5	_ x _ _: Notch width selection 0: α = 2 1: α = 3 2: α = 4 3: α = 5	0h	CP PS SP
	Setting value			Depth					Gain																																
0	Deep	-40dB																																							
1	to	-14dB																																							
2		-8dB																																							
3	Shallow	-4dB																																							
Setting value	Depth	α																																							
0	Standard	2																																							
1	to	3																																							
2		4																																							
3	Wide	5																																							
0 x _ _: Notch width selection	x _ _ _: For manufacturer setting																																								

Part 7: Review on Replacement of MR-J3-_T_ (CC-Link communication operation) with MR-J4-_GF_

MR-J3-_T_			MR-J4-_GF_																																																																							
No.	Name and function	Initial value	No.	Name and function	Initial value	Control mode																																																																				
PB17	Automatic setting parameter This parameter is automatically set according to the set value of [Pr. PB06] (Load to motor inertia ratio).		PB17	Shaft resonance suppression filter Set the shaft resonance suppression filter. Use this to suppress a high-frequency machine vibration. When "Shaft resonance suppression filter selection" in [Pr. PB23] is "Automatic setting (___ 0)", the value will be calculated automatically from the servo motor used and load to motor inertia ratio. When "Manual setting (___ 1)" is set, the content written with this parameter is used. If "Shaft resonance suppression filter selection" in [Pr. PB23] is "Disabled (___ 2)", the setting value is invalid. If "Enabled (___ 1)" is selected for "Machine resonance suppression filter 4 selection" in [Pr. PB49], the shaft resonance suppression filter cannot be used. If "Shaft resonance suppression filter selection" in [Pr. PB23] is "Disabled (___ 2)", the performance may be reduced. ___ x x: Refer to the following table for setting values. Set the value closest to the required frequency.	00h	CP PS SP																																																																				
			___ x ___: Notch depth selection 0: -40 dB 1: -14 dB 2: -8 dB 3: -4 dB	0h	CP PS SP																																																																					
			x ___: For manufacturer setting	0h																																																																						
			Shaft resonance suppression filter setting - Frequency selection																																																																							
				<table border="1"> <thead> <tr> <th>Setting value</th> <th>Frequency [Hz]</th> <th>Setting value</th> <th>Frequency [Hz]</th> </tr> </thead> <tbody> <tr><td>___ 0 0</td><td>Disabled</td><td>___ 1 0</td><td>562</td></tr> <tr><td>___ 0 1</td><td>Disabled</td><td>___ 1 1</td><td>529</td></tr> <tr><td>___ 0 2</td><td>4500</td><td>___ 1 2</td><td>500</td></tr> <tr><td>___ 0 3</td><td>3000</td><td>___ 1 3</td><td>473</td></tr> <tr><td>___ 0 4</td><td>2250</td><td>___ 1 4</td><td>450</td></tr> <tr><td>___ 0 5</td><td>1800</td><td>___ 1 5</td><td>428</td></tr> <tr><td>___ 0 6</td><td>1500</td><td>___ 1 6</td><td>409</td></tr> <tr><td>___ 0 7</td><td>1285</td><td>___ 1 7</td><td>391</td></tr> <tr><td>___ 0 8</td><td>1125</td><td>___ 1 8</td><td>375</td></tr> <tr><td>___ 0 9</td><td>1000</td><td>___ 1 9</td><td>360</td></tr> <tr><td>___ 0 A</td><td>900</td><td>___ 1 A</td><td>346</td></tr> <tr><td>___ 0 B</td><td>818</td><td>___ 1 B</td><td>333</td></tr> <tr><td>___ 0 C</td><td>750</td><td>___ 1 C</td><td>321</td></tr> <tr><td>___ 0 D</td><td>692</td><td>___ 1 D</td><td>310</td></tr> <tr><td>___ 0 E</td><td>642</td><td>___ 1 E</td><td>300</td></tr> <tr><td>___ 0 F</td><td>600</td><td>___ 1 F</td><td>290</td></tr> </tbody> </table>	Setting value	Frequency [Hz]	Setting value	Frequency [Hz]	___ 0 0	Disabled	___ 1 0	562	___ 0 1	Disabled	___ 1 1	529	___ 0 2	4500	___ 1 2	500	___ 0 3	3000	___ 1 3	473	___ 0 4	2250	___ 1 4	450	___ 0 5	1800	___ 1 5	428	___ 0 6	1500	___ 1 6	409	___ 0 7	1285	___ 1 7	391	___ 0 8	1125	___ 1 8	375	___ 0 9	1000	___ 1 9	360	___ 0 A	900	___ 1 A	346	___ 0 B	818	___ 1 B	333	___ 0 C	750	___ 1 C	321	___ 0 D	692	___ 1 D	310	___ 0 E	642	___ 1 E	300	___ 0 F	600	___ 1 F	290		
Setting value	Frequency [Hz]	Setting value	Frequency [Hz]																																																																							
___ 0 0	Disabled	___ 1 0	562																																																																							
___ 0 1	Disabled	___ 1 1	529																																																																							
___ 0 2	4500	___ 1 2	500																																																																							
___ 0 3	3000	___ 1 3	473																																																																							
___ 0 4	2250	___ 1 4	450																																																																							
___ 0 5	1800	___ 1 5	428																																																																							
___ 0 6	1500	___ 1 6	409																																																																							
___ 0 7	1285	___ 1 7	391																																																																							
___ 0 8	1125	___ 1 8	375																																																																							
___ 0 9	1000	___ 1 9	360																																																																							
___ 0 A	900	___ 1 A	346																																																																							
___ 0 B	818	___ 1 B	333																																																																							
___ 0 C	750	___ 1 C	321																																																																							
___ 0 D	692	___ 1 D	310																																																																							
___ 0 E	642	___ 1 E	300																																																																							
___ 0 F	600	___ 1 F	290																																																																							
PB18	Low-pass filter setting Set the low-pass filter. If [Pr. PB23] (low-pass filter selection) is set to "___ 0 ___", this parameter is automatically changed. If [Pr. PB23] is set to "___ 1 ___", this parameter can be set manually.	3141	PB18	Low-pass filter setting Set the low-pass filter. Refer to the table below for the status of this parameter and the setting values of the related parameter. Setting range: 100 to 18000	3141	CP PS SP																																																																				
				<table border="1"> <thead> <tr> <th>[Pr. PB23]</th> <th>[Pr. PB18]</th> </tr> </thead> <tbody> <tr> <td>___ 0 _ (initial value)</td> <td>Automatic setting</td> </tr> <tr> <td>___ 1 _</td> <td>Setting value enabled</td> </tr> <tr> <td>___ 2 _</td> <td>Setting value disabled</td> </tr> </tbody> </table>	[Pr. PB23]	[Pr. PB18]	___ 0 _ (initial value)	Automatic setting	___ 1 _	Setting value enabled	___ 2 _	Setting value disabled																																																														
[Pr. PB23]	[Pr. PB18]																																																																									
___ 0 _ (initial value)	Automatic setting																																																																									
___ 1 _	Setting value enabled																																																																									
___ 2 _	Setting value disabled																																																																									

Part 7: Review on Replacement of MR-J3-_T_ (CC-Link communication operation) with MR-J4-_GF_

MR-J3-_T_			MR-J4-_GF_			Control mode
No.	Name and function	Initial value	No.	Name and function	Initial value	
PB19	<p>Vibration suppression control - Vibration frequency</p> <p>Set the vibration frequency of vibration suppression control to suppress low-frequency machine vibration such as chassis vibration.</p> <p>If [Pr. PB02] (vibration suppression control tuning mode) is set to "___ 1", this parameter is automatically changed. If [Pr. PB02] is set to "___ 2", this parameter can be set manually.</p>	100.0	PB19	<p>Vibration suppression control 1 - Vibration frequency</p> <p>Set the vibration frequency of vibration suppression control 1 to suppress low-frequency machine vibration.</p> <p>When "Automatic setting (___ 1)" is selected for [Vibration suppression control 1 - Tuning mode selection] in [Pr. PB02], this parameter will be set automatically. If "Manual setting (___ 2)" is set, the value written for this parameter is used. For details, refer to "MR-J4-_GF_(-RJ) Servo Amplifier Instruction Manual (Motion Mode)".</p> <p>Setting range: 0.1 to 300.0</p>	100.0	CP PS
PB20	<p>Vibration suppression control - Resonance frequency</p> <p>Set the resonance frequency of vibration suppression control to suppress low-frequency machine vibration such as chassis vibration.</p> <p>If [Pr. PB02] (vibration suppression control tuning mode) is set to "___ 1", this parameter is automatically changed. If [Pr. PB02] is set to "___ 2", this parameter can be set manually.</p>	100.0	PB20	<p>Vibration suppression control 1 - Resonance frequency</p> <p>Set the resonance frequency of vibration suppression control 1 to suppress low-frequency machine vibration.</p> <p>When "Automatic setting (___ 1)" is selected for [Vibration suppression control 1 - Tuning mode selection] in [Pr. PB02], this parameter will be set automatically. If "Manual setting (___ 2)" is set, the value written for this parameter is used. For details, refer to "MR-J4-_GF_(-RJ) Servo Amplifier Instruction Manual (Motion Mode)".</p> <p>Setting range: 0.1 to 300.0</p>	100.0	CP PS
PB23	<p>Low-pass filter selection</p> <p>Select the low-pass filter.</p> <p>0 0 x 0:</p> <p>Low-pass filter selection</p> <p>0: Automatic setting</p> <p>1: Manual setting (setting value of [Pr. PB18])</p>	0000h	PB23	<p>Low-pass filter selection</p> <p>___ x:</p> <p>Shaft resonance suppression filter selection</p> <p>Select the shaft resonance suppression filter.</p> <p>0: Automatic setting</p> <p>1: Manual setting</p> <p>2: Disabled</p> <p>If "Enabled (___ 1)" is selected for "Machine resonance suppression filter 4 selection" in [Pr. PB49], the shaft resonance suppression filter cannot be used.</p>	0h	CP PS SP
				<p>__ x _:</p> <p>Low-pass filter selection</p> <p>Select the low-pass filter.</p> <p>0: Automatic setting</p> <p>1: Manual setting</p> <p>2: Disabled</p>	0h	CP PS SP
				<p>_ x _:</p> <p>For manufacturer setting</p>	0h	
				<p>x _ _:</p> <p>For manufacturer setting</p>	0h	

Part 7: Review on Replacement of MR-J3-_T_ (CC-Link communication operation) with MR-J4-_GF_

MR-J3-_T_			MR-J4-_GF_			
No.	Name and function	Initial value	No.	Name and function	Initial value	Control mode
PB24	Slight vibration suppression control selection Select the slight vibration suppression control. The slight vibration suppression control is enabled if [Pr. PA08] (auto tuning mode) is set to "___3". 0 0 0 x: Slight vibration suppression control selection 0: Disabled 1: Enabled	0000h	PB24	Slight vibration suppression control ___x: Slight vibration suppression control selection Select the slight vibration suppression control. 0: Disabled 1: Enabled The slight vibration suppression control is enabled when "Manual mode (___3)" is selected for "Gain adjustment mode selection" in [Pr. PA08]. Slight vibration suppression control selection cannot be used in speed control mode (point table method).	0h	CP PS
				PI-PID switching control selection 0: PI control enabled ___x: (Switching to PID control (proportional control) is enabled by PID switching signal from controller and the input device PC (proportional control).) 3: PID control (proportional control) is always enabled. If the servo motor at a stop is rotated even for a pulse due to any external factor, it generates torque to compensate for a position mismatch. When the servo motor shaft is to be locked mechanically after positioning completion (stop), enabling the PID control and completing positioning simultaneously will suppress the unnecessary torque generated to compensate for a position mismatch.	0h	CP PS
				__x__: For manufacturer setting	0h	
				x___: For manufacturer setting	0h	
PB26	Gain switching selection Select the gain switching condition. 0 0 _x: Gain switching selection Under the following conditions, the gain is switched based on the setting values of [Pr. PB29] to [Pr. PB34]. 0: Disabled 1: Gain switching (RY (n + 2) 8) 2: Command frequency (setting value of [Pr. PB27]) 3: Droop pulses (setting value of [Pr. PB27]) 4: Servo motor speed (setting value of [Pr. PB27])	0000h	PB26	Gain switching function Select the gain switching condition. Set conditions to enable the gain switching values set in [Pr. PB29] to [Pr. PB36] and [Pr. PB56] to [Pr. PB60]. ___x: Gain switching selection 0: Disabled 1: Control commands from the controller and input devices (CDP (gain switching)) are enabled. 2: Command frequency 3: Droop pulses 4: Servo motor speed	0h	CP PS SP
				___x__: Gain switching - Condition selection 0: Gain after switching is enabled with the condition value or more for gain switching. 1: Gain after switching is enabled with the condition value or less for gain switching.	0h	CP PS SP
				__x__: For manufacturer setting	0h	
				x___: For manufacturer setting	0h	
PB27	Gain switching condition Set the value of the gain switching condition (command frequency, droop pulses, or servo motor speed) selected in [Pr. PB26]. The set value unit differs depending on the switching condition item.	10	PB27	Gain switching condition Set the value of the gain switching (command frequency, droop pulses, or servo motor speed) selected in [Pr. PB26]. The set value unit differs depending on the switching condition item. (Refer to "MR-J4-_GF_(-RJ) Servo Amplifier Instruction Manual (Motion Mode)".) Setting range: 0 to 65535	10	CP PS SP

Part 7: Review on Replacement of MR-J3-_T_ (CC-Link communication operation) with MR-J4-_GF_

MR-J3-_T_			MR-J4-_GF_			Control mode
No.	Name and function	Initial value	No.	Name and function	Initial value	
PB28	Gain switching time constant Set the time constant at which the gain switches in response to the conditions set in [Pr. PB26] and [Pr. PB27].	1	PB28	Gain switching time constant Set the time constant until the gain switches in response to the conditions set in [Pr. PB26] and [Pr. PB27]. Setting range: 0 to 100	1	CP PS SP
PB29	Load to motor inertia ratio after gain switching Set the load to motor inertia ratio for the servo motor of when the gain switching is enabled. This parameter is enabled when auto tuning is disabled ([Pr. PA08]: "___3").	7.0	PB29	Gain switching - Load to motor inertia ratio Set the load to motor inertia ratio for when the gain switching is enabled. This parameter is enabled only when "Manual mode (___3)" is selected for "Gain adjustment mode selection" in [Pr. PA08]. Setting range: 0.00 to 300.00	7.00	CP PS
PB30	Gain switching - Position control gain Set the position control gain for when the gain switching is enabled. This parameter is enabled when auto tuning is disabled ([Pr. PA08]: "___3").	37	PB30	Gain switching - Position control gain Set the position control gain for when the gain switching is enabled. If a value less than 1.0 rad/s is set, the value will be the same as the value set in [Pr. PB08]. This parameter is enabled only when "Manual mode (___3)" is selected for "Gain adjustment mode selection" in [Pr. PA08]. Setting range: 0.0 to 2000.0	0.0	CP PS
PB31	Gain switching - Speed control gain Set the speed control gain for when the gain switching is enabled. This parameter is enabled when auto tuning is disabled ([Pr. PA08]: "___3").	823	PB31	Gain switching - Speed control gain Set the speed control gain for when the gain switching is enabled. If a value less than 20 rad/s is set, the value will be the same as the value set in [Pr. PB09]. This parameter is enabled only when "Manual mode (___3)" is selected for "Gain adjustment mode selection" in [Pr. PA08]. Setting range: 0 to 65535	0	CP PS
PB32	Speed integral compensation after gain switching Set the speed integral compensation for when the gain switching is enabled. This parameter is enabled when auto tuning is disabled ([Pr. PA08]: "___3").	33.7	PB32	Speed integral compensation after gain switching Set the speed integral compensation for when the gain switching is enabled. If a value less than 0.1 ms is set, the value will be the same as the value set in [Pr. PB10]. This parameter is enabled only when "Manual mode (___3)" is selected for "Gain adjustment mode selection" in [Pr. PA08]. Setting range: 0.0 to 5000.0	0.0	CP PS SP
PB33	Vibration frequency for vibration suppression control after gain switching Set the vibration frequency of vibration suppression control for when the gain switching is enabled. This parameter is enabled when [Pr. PB02] is "___2" or [Pr. PB26] is "___1". When using vibration suppression control gain switching, switch the gains after the servo motor has stopped.	100.0	PB33	Gain switching - Vibration suppression control 1 - Vibration frequency Set the vibration frequency of vibration suppression control 1 for when the gain switching is enabled. If a value less than 0.1 Hz is set, the value will be the same as the value set in [Pr. PB19]. This parameter is enabled only under the following conditions. <ul style="list-style-type: none"> ▪ "Manual mode (___3)" is selected for "Gain adjustment mode selection" in [Pr. PA08]. ▪ "Manual setting (___2)" is selected for "Vibration suppression control 1 - Tuning mode selection" in [Pr. PB02]. ▪ "Control commands from the controller and input devices CDP (gain switching) (___1)" is selected for "Gain switching selection" in [Pr. PB26]. Switching gains during driving may cause a shock. Always switch the gains after the servo motor has stopped. Setting range: 0.0 to 300.0	0.0	CP PS

Part 7: Review on Replacement of MR-J3-_T_ (CC-Link communication operation) with MR-J4-_GF_

MR-J3-_T_			MR-J4-_GF_			
No.	Name and function	Initial value	No.	Name and function	Initial value	Control mode
PB34	<p>Resonance frequency for vibration suppression control after gain switching</p> <p>Set the resonance frequency for vibration suppression control for when the gain switching is enabled.</p> <p>This parameter is enabled when [Pr. PB02] is "___2" or [Pr. PB26] is "___1". When using vibration suppression control gain switching, switch the gains after the servo motor has stopped.</p>	100.0	PB34	<p>Vibration suppression control 1 - Resonance frequency after gain switching</p> <p>Set the resonance frequency for vibration suppression control 1 for when the gain switching is enabled.</p> <p>If a value less than 0.1 Hz is set, the value will be the same as the value set in [Pr. PB20].</p> <p>This parameter is enabled only under the following conditions.</p> <ul style="list-style-type: none"> ▪ "Manual mode (___3)" is selected for "Gain adjustment mode selection" in [Pr. PA08]. ▪ "Manual setting (___2)" is selected for "Vibration suppression control 1 - Tuning mode selection" in [Pr. PB02]. ▪ "Control commands from the controller and input devices (CDP (gain switching)) (___1)" is selected for "Gain switching selection" in [Pr. PB26]. <p>Switching gains during driving may cause a shock. Always switch the gains after the servo motor has stopped.</p> <p>Setting range: 0.0 to 300.0</p>	0.0	CP PS

Part 7: Review on Replacement of MR-J3-_T_ (CC-Link communication operation) with MR-J4-_GF_

MR-J3-_T_			MR-J4-_GF_																																																																																																																			
No.	Name and function	Initial value	No.	Name and function	Initial value	Control mode																																																																																																																
PC02	Home position return type Select the homing method. 0 0 0 x: Homing methods * For point table positioning operation 0: Dog type 1: Count type 2: Data set type 3: Stopper type 4: Home position ignorance (servo-on position as home position) 5: Dog type rear end reference 6: Count type front end reference 7: Dog cradle type 8: Dog type last Z-phase reference 9: Dog type front end reference A: Dogless Z-phase reference * For indexer positioning operation C: Torque limit changing dog type D: Torque limit changing data set type	0000h	PT45	Homing methods Set a homing method. Refer to the following table for the homing of the replacement destination. For other homing methods, refer to "MR-J4-_GF_ (-RJ) Servo Amplifier Instruction Manual (I/O Mode)".	37	CP PS																																																																																																																
				Homing methods <table border="1"> <thead> <tr> <th>Setting value</th> <th>Homing direction</th> <th>Homing methods</th> <th>Control method</th> </tr> </thead> <tbody> <tr> <td rowspan="2">-1</td> <td rowspan="2">Address increasing direction</td> <td>Dog type (Rear end detection - Z-phase reference)</td> <td>CP</td> </tr> <tr> <td>Torque limit changing dog type</td> <td>PS</td> </tr> <tr> <td rowspan="2">-2</td> <td rowspan="2"></td> <td>Count type (Front end detection - Z-phase reference)</td> <td>CP</td> </tr> <tr> <td>Torque limit changing data set type</td> <td>PS</td> </tr> <tr> <td rowspan="2">-4</td> <td rowspan="2">Address increasing direction</td> <td>Stopper type (Stopper position reference)</td> <td>CP</td> </tr> <tr> <td>Home position ignorance (servo-on position as home position)</td> <td></td> </tr> <tr> <td rowspan="2">-6</td> <td rowspan="2">Address increasing direction</td> <td>Dog type (Rear end detection - rear end reference)</td> <td></td> </tr> <tr> <td>Count type (Front end detection - front end reference)</td> <td></td> </tr> <tr> <td rowspan="2">-7</td> <td rowspan="2"></td> <td>Dog cradle type</td> <td></td> </tr> <tr> <td>Dog type last Z-phase reference</td> <td></td> </tr> <tr> <td rowspan="2">-8</td> <td rowspan="2"></td> <td>Dog type front end reference</td> <td></td> </tr> <tr> <td>Dogless Z-phase reference</td> <td></td> </tr> <tr> <td rowspan="2">-9</td> <td rowspan="2"></td> <td></td> <td></td> </tr> <tr> <td></td> <td></td> </tr> <tr> <td rowspan="2">-10</td> <td rowspan="2"></td> <td></td> <td></td> </tr> <tr> <td></td> <td></td> </tr> <tr> <td rowspan="2">-11</td> <td rowspan="2"></td> <td></td> <td></td> </tr> <tr> <td></td> <td></td> </tr> <tr> <td rowspan="2">-33</td> <td rowspan="2">Address decreasing direction</td> <td>Dog type (Rear end detection - Z-phase reference)</td> <td>CP</td> </tr> <tr> <td>Torque limit changing dog type</td> <td>PS</td> </tr> <tr> <td rowspan="2">-34</td> <td rowspan="2"></td> <td>Count type (Front end detection - Z-phase reference)</td> <td>CP</td> </tr> <tr> <td>Stopper type (Stopper position reference)</td> <td></td> </tr> <tr> <td rowspan="2">-36</td> <td rowspan="2"></td> <td>Dog type (Rear end detection - rear end reference)</td> <td></td> </tr> <tr> <td>Count type (Front end detection - front end reference)</td> <td></td> </tr> <tr> <td rowspan="2">-38</td> <td rowspan="2"></td> <td>Dog cradle type</td> <td></td> </tr> <tr> <td>Dog type last Z-phase reference</td> <td></td> </tr> <tr> <td rowspan="2">-39</td> <td rowspan="2"></td> <td>Dog type front end reference</td> <td></td> </tr> <tr> <td>Dogless Z-phase reference</td> <td></td> </tr> <tr> <td rowspan="2">-40</td> <td rowspan="2"></td> <td></td> <td></td> </tr> <tr> <td></td> <td></td> </tr> <tr> <td rowspan="2">-41</td> <td rowspan="2"></td> <td></td> <td></td> </tr> <tr> <td></td> <td></td> </tr> <tr> <td rowspan="2">-42</td> <td rowspan="2"></td> <td></td> <td></td> </tr> <tr> <td></td> <td></td> </tr> <tr> <td rowspan="2">-43</td> <td rowspan="2"></td> <td></td> <td></td> </tr> <tr> <td></td> <td></td> </tr> <tr> <td rowspan="2">37</td> <td rowspan="2"></td> <td>Data set type</td> <td></td> </tr> <tr> <td></td> <td></td> </tr> </tbody> </table>			Setting value	Homing direction	Homing methods	Control method	-1	Address increasing direction	Dog type (Rear end detection - Z-phase reference)	CP	Torque limit changing dog type	PS	-2		Count type (Front end detection - Z-phase reference)	CP	Torque limit changing data set type	PS	-4	Address increasing direction	Stopper type (Stopper position reference)	CP	Home position ignorance (servo-on position as home position)		-6	Address increasing direction	Dog type (Rear end detection - rear end reference)		Count type (Front end detection - front end reference)		-7		Dog cradle type		Dog type last Z-phase reference		-8		Dog type front end reference		Dogless Z-phase reference		-9						-10						-11						-33	Address decreasing direction	Dog type (Rear end detection - Z-phase reference)	CP	Torque limit changing dog type	PS	-34		Count type (Front end detection - Z-phase reference)	CP	Stopper type (Stopper position reference)		-36		Dog type (Rear end detection - rear end reference)		Count type (Front end detection - front end reference)		-38		Dog cradle type		Dog type last Z-phase reference		-39		Dog type front end reference		Dogless Z-phase reference		-40						-41						-42						-43					
Setting value	Homing direction	Homing methods	Control method																																																																																																																			
-1	Address increasing direction	Dog type (Rear end detection - Z-phase reference)	CP																																																																																																																			
		Torque limit changing dog type	PS																																																																																																																			
-2		Count type (Front end detection - Z-phase reference)	CP																																																																																																																			
		Torque limit changing data set type	PS																																																																																																																			
-4	Address increasing direction	Stopper type (Stopper position reference)	CP																																																																																																																			
		Home position ignorance (servo-on position as home position)																																																																																																																				
-6	Address increasing direction	Dog type (Rear end detection - rear end reference)																																																																																																																				
		Count type (Front end detection - front end reference)																																																																																																																				
-7		Dog cradle type																																																																																																																				
		Dog type last Z-phase reference																																																																																																																				
-8		Dog type front end reference																																																																																																																				
		Dogless Z-phase reference																																																																																																																				
-9																																																																																																																						
-10																																																																																																																						
-11																																																																																																																						
-33	Address decreasing direction	Dog type (Rear end detection - Z-phase reference)	CP																																																																																																																			
		Torque limit changing dog type	PS																																																																																																																			
-34		Count type (Front end detection - Z-phase reference)	CP																																																																																																																			
		Stopper type (Stopper position reference)																																																																																																																				
-36		Dog type (Rear end detection - rear end reference)																																																																																																																				
		Count type (Front end detection - front end reference)																																																																																																																				
-38		Dog cradle type																																																																																																																				
		Dog type last Z-phase reference																																																																																																																				
-39		Dog type front end reference																																																																																																																				
		Dogless Z-phase reference																																																																																																																				
-40																																																																																																																						
-41																																																																																																																						
-42																																																																																																																						
-43																																																																																																																						
37		Data set type																																																																																																																				
PC03	Homing direction Select the homing direction. 0 0 0 x: Homing direction 0: Address increasing direction/Station No. increasing direction 1: Address decreasing direction/Station No. decreasing direction	0001h	PT70	Function selection T-10 Torque limit changing dog type homing function selection ___ x: <table border="1"> <thead> <tr> <th>Setting value</th> <th>Proximity dog detection end</th> <th>Automatic retract function used for the home position return</th> </tr> </thead> <tbody> <tr> <td>0</td> <td>Front end detection Stops with reference to the first Z-phase after passing the front end of the proximity dog.</td> <td>Disabled</td> </tr> <tr> <td>1</td> <td>Rear end detection Stops with reference to the first Z-phase after the rear end of the proximity dog is passed.</td> <td>Disabled</td> </tr> <tr> <td>2</td> <td>Front end detection Stops with reference to the first Z-phase after passing the front end of the proximity dog.</td> <td>Enabled</td> </tr> <tr> <td>3</td> <td>Rear end detection Stops with reference to the first Z-phase after the rear end of the proximity dog is passed.</td> <td>Enabled</td> </tr> </tbody> </table>	Setting value	Proximity dog detection end	Automatic retract function used for the home position return	0	Front end detection Stops with reference to the first Z-phase after passing the front end of the proximity dog.	Disabled	1	Rear end detection Stops with reference to the first Z-phase after the rear end of the proximity dog is passed.	Disabled	2	Front end detection Stops with reference to the first Z-phase after passing the front end of the proximity dog.	Enabled	3	Rear end detection Stops with reference to the first Z-phase after the rear end of the proximity dog is passed.	Enabled	0h	PS																																																																																																	
				Setting value	Proximity dog detection end	Automatic retract function used for the home position return																																																																																																																
0	Front end detection Stops with reference to the first Z-phase after passing the front end of the proximity dog.	Disabled																																																																																																																				
1	Rear end detection Stops with reference to the first Z-phase after the rear end of the proximity dog is passed.	Disabled																																																																																																																				
2	Front end detection Stops with reference to the first Z-phase after passing the front end of the proximity dog.	Enabled																																																																																																																				
3	Rear end detection Stops with reference to the first Z-phase after the rear end of the proximity dog is passed.	Enabled																																																																																																																				
___ x _: For manufacturer setting	0h																																																																																																																					
				_ x _ _: For manufacturer setting	0h																																																																																																																	
				x _ _ _: For manufacturer setting	0h																																																																																																																	

Part 7: Review on Replacement of MR-J3-_T_ (CC-Link communication operation) with MR-J4-_GF_

MR-J3-_T_			MR-J4-_GF_			Control mode
No.	Name and function	Initial value	No.	Name and function	Initial value	
PC04	Homing speed Set the servo motor speed for homing.	500	PT05	Homing speed Set the servo motor speed for homing. Setting range: 0.00 to instantaneous permissible speed	100.00	CP PS
PC05	Creep speed Set the creep speed after proximity dog detection.	10	PT06	Creep speed Set a creep speed after proximity dog at homing. Setting range: 0.00 to instantaneous permissible speed	10.00	CP PS
PC06	Home position shift distance Set the travel distance from the home position.	0	PT07	Home position shift distance Set the shift travel distance from the point where a Z-phase pulse is detected in the encoder or the point set by the travel distance after proximity dog. A value of up to $2^{31} - 1$ can be set in [Pr. PT69]. For the home position shift direction, refer to section 4.6 of "MR-J4-_GF_(-RJ) Servo Amplifier Instruction Manual (Motion Mode)". The unit is as follows depending on the positioning mode. <ul style="list-style-type: none"> ▪ For the point table method The unit is [μm]. ▪ For the indexer method The unit is command unit [pulse]. (A unit that expresses one rotation on the machine side by the number of servo motor resolution pulses) For the command unit, refer to the function column of [Pr. PA10]. Setting range: 0 to 65535	0	CP PS
			PT69	Home position shift distance (extension parameter) Set the extension parameters of [Pr. PT07]. When using [Pr. PT69], the home position shift distance is calculated as follows. Home position shift distance = [Pr. PT07] + ([Pr. PT69] \times 65536) For the home position shift direction, refer to section 4.6 of "MR-J4-_GF_(-RJ) Servo Amplifier Instruction Manual (Motion Mode)". The unit is as follows depending on the positioning mode. <ul style="list-style-type: none"> ▪ For the point table method The unit is [μm]. ▪ For the indexer method The unit is command unit [pulse]. (A unit that expresses one rotation on the machine side by the number of servo motor resolution pulses) For the command unit, refer to the function column of [Pr. PA10]. If a value of "1001" or higher is set, the value is clamped at "1000". Setting range: 0 to 32767	0	CP PS

Part 7: Review on Replacement of MR-J3-_T_ (CC-Link communication operation) with MR-J4-_GF_

MR-J3-_T_			MR-J4-_GF_			Control mode
No.	Name and function	Initial value	No.	Name and function	Initial value	
PC07	Homing position data Set the current position at home position return completion.	0	PT08	Homing position data Set the current position at home position return completion. A value of up to $2^{31} - 1$ can be set in [Pr. PT47]. If the following parameter is changed, the homing position data will also be changed. Execute homing again. ▪ "Unit for position data" in [Pr. PT01] Setting range: 0 to 65535	0	CP
			PT47	Home position return position data (extension parameter) Set the extension parameters of [Pr. PT08]. When using [Pr. PT47], the homing position data is calculated as follows. Homing position data = [Pr. PT08] + ([Pr. PT47] × 65536) Setting range: -32768 to 32767	0	CP
PC08	Travel distance after proximity dog Set the travel distance after proximity dog detection.	1000	PT09	Travel distance after proximity dog Set a travel distance after proximity dog for homing for the count type (Front end detection Z-phase reference) and the following dog reference. ▪ Dog type rear end reference homing ▪ Count type homing (front end reference) ▪ Dog type front end reference homing A value of up to 2^{31} can be set in [Pr. PT71]. Setting range: 0 to 65535	0	CP
			PT71	Travel distance after proximity dog (extension parameter) Set the extension parameters of [Pr. PT09]. When using [Pr. PT71], the travel distance after proximity dog is calculated as follows. Travel distance after proximity dog = [Pr. PT09] + ([Pr. PT71] × 65536) Setting range: 0 to 32767	0	CP
PC09	Stopper type home position return - Stopper time Set a time from a moving part touches the stopper and torques reach the torque limit of [Pr. PC10] to a home position is set for the stopper type homing.	100	PT10	Stopper type home position return - Stopper time Set a time from a moving part touches the stopper and torques reach the torque limit value of [Pr. PT11] Stopper type homing - Torque limit value] to a home position is set for the stopper type homing. Setting range: 5 to 1000	100	CP
PC10	Stopper type home position return - Torque limit value Set a torque limit value with [%] to the maximum torque at stopper type homing.	15.0	PT11	Stopper type home position return - Torque limit value Set a torque limit value with [%] to the maximum torque at stopper type homing. Setting range: 0.1 to 100.0	15.0	CP
PC11	Rough match output range Set the range of the command remaining distance to output the rough match (CPO).	0	PT12	Rough match output range Set the range of the command remaining distance to output the rough match. The unit is as follows depending on the positioning mode. ▪ For the point table method The unit is [μ m]. ▪ For the indexer method The unit is command unit [pulse]. (A unit that expresses one rotation on the machine side by the number of servo motor resolution pulses) For the command unit, refer to the function column of [Pr. PA10]. Setting range: 0 to 65535	0	CP PS

Part 7: Review on Replacement of MR-J3-_T_ (CC-Link communication operation) with MR-J4-_GF_

MR-J3-_T_			MR-J4-_GF_			Control mode
No.	Name and function	Initial value	No.	Name and function	Initial value	
PC12	JOG speed Set the JOG speed command.	100	PT65	JOG speed command Set the JOG speed command. If a value smaller than "1.00" is set, the servo motor may not rotate. Setting range: 0.00 to Instantaneous permissible speed	100.00	CP PS
PC13	S-pattern acceleration/deceleration time constants Set this parameter when inserting the S-pattern acceleration/deceleration time constant for the acceleration/deceleration time constant of the point table. These time constants are disabled during homing.	0	PT51	S-pattern acceleration/deceleration time constants This setting enables smooth start and stop of the servo motor. Set the time of the arc part at S-pattern acceleration/deceleration. By setting "0", linear acceleration/deceleration is performed. This parameter is disabled during homing. Servo operation normally performs linear acceleration and deceleration, but it can be started and stopped smoothly by setting [Pr. PT51 S-pattern acceleration/deceleration time constants]. When the S-pattern acceleration/deceleration time constant is set, smooth positioning is performed as shown in the following figure. If the S-pattern acceleration/deceleration time constant is set, the time from start to output of MEND (travel completion) becomes longer by the amount of S-pattern acceleration/deceleration time constant. <p>Ta: Time it takes to reach the set speed Tb: Time it takes to come to a stop If the STC value is set longer than the constant speed time, the speed may not reach the command speed. Also, if a value of 1000 ms or more is set, the value is clamped to 1000 ms.</p> Setting range: 0 to 5000	0	CP SP
PC14	Backlash compensation Set the backlash compensation to be compensated when the command direction is reversed. The number of backlash pulses is compensated in the reverse direction with respect to the homing direction. For home position ignorance (servo-on position as home position), the number of backlash pulses is compensated in the reverse direction with respect to the direction in which the first rotation starts after the homing position is determined by turning on Servo-on (RYn0). For the absolute position detection system, compensation is performed in the reverse direction with respect to the operation direction at power-on.	0	PT14	Backlash compensation Set the backlash compensation. When the command direction of automatic operation is reversed, it stops at the position compensated by the value set for the backlash compensation. The backlash correction direction is determined by the homing direction immediately before the home position return is completed. For home position ignorance (servo-on position as home position), compensation is performed in the reverse direction with respect to the direction in which the first rotation starts after the homing position is determined by turning on RYn0 (Servo-on). For the absolute position detection system, compensation is performed in the reverse direction with respect to the operation direction at power-on. Setting range: 0 to 65535	0	CP PS
PC16	Electromagnetic brake sequence output Set the delay time (Tb) used between the Electromagnetic brake interlock (MBR) shut-off and the base circuit shut-off.	100	PC02	Electromagnetic brake sequence output Set the delay time used between the MBR (Electromagnetic brake interlock) shut-off and the base circuit shut-off. Setting range: 0 to 1000	0	CP PS SP

Part 7: Review on Replacement of MR-J3-_T_ (CC-Link communication operation) with MR-J4-_GF_

MR-J3-_T_			MR-J4-_GF_			Control mode
No.	Name and function	Initial value	No.	Name and function	Initial value	
PC14	<p>Backlash compensation</p> <p>Set the backlash compensation to be compensated when the command direction is reversed.</p> <p>The number of backlash pulses is compensated in the reverse direction with respect to the homing direction. For home position ignorance (servo-on position as home position), the number of backlash pulses is compensated in the reverse direction with respect to the direction in which the first rotation starts after the homing position is determined by turning on Servo-on (RYn0).</p> <p>For the absolute position detection system, compensation is performed in the reverse direction with respect to the operation direction at power-on.</p>	0	PT14	<p>Backlash compensation</p> <p>Set the backlash compensation.</p> <p>When the command direction of automatic operation is reversed, it stops at the position compensated by the value set for the backlash compensation.</p> <p>The backlash correction direction is determined by the homing direction immediately before the home position return is completed. For home position ignorance (servo-on position as home position), compensation is performed in the reverse direction with respect to the direction in which the first rotation starts after the homing position is determined by turning on RYn0 (Servo-on).</p> <p>For the absolute position detection system, compensation is performed in the reverse direction with respect to the operation direction at power-on.</p> <p>Setting range: 0 to 65535</p>	0	CP PS
PC16	<p>Electromagnetic brake sequence output</p> <p>Set the delay time (Tb) used between the Electromagnetic brake interlock (MBR) shut-off and the base circuit shut-off.</p>	100	PC02	<p>Electromagnetic brake sequence output</p> <p>Set the delay time used between the MBR (Electromagnetic brake interlock) shut-off and the base circuit shut-off.</p> <p>Setting range: 0 to 1000</p>	0	CP PS SP
PC17	<p>Zero speed</p> <p>Set an output range of the zero speed detection (ZSP).</p> <p>The zero speed detection (ZSP) has a hysteresis width of 20 r/min.</p>	50	PC07	<p>Zero speed</p> <p>Set the output range of ZSP (zero speed detection). ZSP (zero speed detection) has a hysteresis of 20 r/min.</p> <p>Setting range: 0 to 10000</p>	50	CP PS SP
PC18	<p>Alarm history clear</p> <p>Clears the alarm history.</p> <p>0 0 0 x:</p> <p>Alarm history clear</p> <p>0: Disabled</p> <p>1: Enabled</p> <p>When Alarm history clear is enabled, the alarm history will be cleared at the next power-on.</p> <p>Alarm history clear is disabled (0) automatically after the alarm history is cleared.</p>	0000h	PC21	<p>Alarm history clear</p> <p>___ x:</p> <p>Alarm clear history selection</p> <p>Clears the alarm history.</p> <p>0: Disabled</p> <p>1: Enabled</p> <p>When "Enabled" is selected, the alarm history will be cleared at the next power-on. Alarm history clear is disabled automatically after the alarm history is cleared.</p>	0h	CP PS SP
				<p>__ x _:</p> <p>For manufacturer setting</p>	0h	
				<p>_ x _ _:</p> <p>For manufacturer setting</p>	0h	
				<p>x _ _ _:</p> <p>For manufacturer setting</p>	0h	

Part 7: Review on Replacement of MR-J3-_T_ (CC-Link communication operation) with MR-J4-_GF_

MR-J3-_T_			MR-J4-_GF_																											
No.	Name and function	Initial value	No.	Name and function	Initial value	Control mode																								
PC19	Detector output pulse selection Select the detector output pulse direction and detector output pulse setting. 0 0 _ x: Detector output pulse phase change Change the detector output pulse phase between A-phase and B-phase.	0000h	PC03	Encoder output pulses selection __ _ x: Encoder output pulse phase selection Select the encoder pulse direction. 0: Increasing A-phase 90° in CCW 1: Increasing A-phase 90° in CW	0h	CP PS SP																								
							<table border="1"> <thead> <tr> <th rowspan="2">Setting value</th> <th colspan="2">Servo motor rotation direction</th> </tr> <tr> <th>CCW</th> <th>CW</th> </tr> </thead> <tbody> <tr> <td>0</td> <td> </td> <td> </td> </tr> <tr> <td>1</td> <td> </td> <td> </td> </tr> </tbody> </table>	Setting value	Servo motor rotation direction		CCW	CW	0			1			<table border="1"> <thead> <tr> <th rowspan="2">Setting value</th> <th colspan="2">Servo motor rotation direction</th> </tr> <tr> <th>CCW</th> <th>CW</th> </tr> </thead> <tbody> <tr> <td>0</td> <td> </td> <td> </td> </tr> <tr> <td>1</td> <td> </td> <td> </td> </tr> </tbody> </table>	Setting value	Servo motor rotation direction		CCW	CW	0			1		
							Setting value		Servo motor rotation direction																					
								CCW	CW																					
0																														
1																														
Setting value	Servo motor rotation direction																													
	CCW	CW																												
0																														
1																														
0 0 x _: Detector output pulse setting selection 0: Output pulse setting 1: Dividing ratio setting 2: Command pulse unit ratio automatic setting When "2" is set, the setting value of [Pr. PA15] (Detector output pulse) is disabled.	__ _ x _: Encoder output pulse setting selection 0: Output pulse setting 1: Dividing ratio setting 2: The same output pulse setting as the command pulse unit 3: A-phase/B-phase pulse electronic gear setting 4: A/B-phase pulse through output setting When "2" is set, the setting value of [Pr. PA15] (Encoder output pulse) is disabled. Also, the servo motor side pulse unit is used in the indexer method. When using this setting, do not change the settings of [Pr. PA06] and [Pr. PA07] after power-on. For details, refer to Appendix 15 of "MR-J4-_GF_(-RJ) Servo Amplifier Instruction Manual (Motion Mode)".	0h	CP PS SP																											
			_ x _ _: For manufacturer setting	0h																										
			x _ _ _: For manufacturer setting	0h																										
PC20	Setting station numbers Specify the servo amplifier station No. for RS-422 communication and USB communication. Always set one station for one servo amplifier. If the same station No. is used for multiple servo amplifiers, the communication will fail.	0		No corresponding parameter																										
PC21	RS-422 communication function selection Select the RS-422 communication function. 0_ x 0: RS-422 communication - Baud rate selection 0: 9600 [bps] 1: 19200 [bps] 2: 38400 [bps] 3: 57600 [bps] 4: 115200 [bps]	0000h		No corresponding parameter																										
	0 x _ 0: RS-422 communication response delay time 0: Disabled 1: Enabled (Data is returned with a delay of 800 μs or longer.)																													

Part 7: Review on Replacement of MR-J3-_T_ (CC-Link communication operation) with MR-J4-_GF_

MR-J3-_T_			MR-J4-_GF_			Control mode
No.	Name and function	Initial value	No.	Name and function	Initial value	
PC22	Function selection C-1 Select the method by which detector cable communication is to be performed. x 0 0 0: Detector cable communication method selection 0: Two-wire type 1: Four-wire type If the value is set incorrectly, [AL.16 Detector error 1] or [AL.20 Detector error 2] will occur.	0000h	PC04	Function selection C-1 ___x: For manufacturer setting	0h	CP PS SP
				__x_: For manufacturer setting	0h	
				x: For manufacturer setting	0h	
				x___: Encoder cable communication method selection Select the communication method of encoder cables. 0: Two-wire type 1: Four-wire type When using an encoder of A/B/Z-phase differential output method, set "0". If the value is set incorrectly, [AL. 16 Encoder initial communication error 1] or [AL. 20 Encoder normal communication error 1] occurs.	0h	
PC24	Function selection C-3 Select a unit of the in-position range. 0 0 0 x: In-position range unit selection 0: Command input unit 1: Servo motor detector unit	0000h	PC06	Function selection C-3 ___x: In-position range unit selection Select a unit of the in-position range. 0: Command input pulse unit 1: Servo motor encoder pulse unit	0h	CP PS SP
				__x_: For manufacturer setting	0h	
				x: For manufacturer setting	0h	
				Excessive error alarm and excessive error warning trigger level unit selection x___: Select the unit used when setting the excessive error alarm trigger level in [Pr. PC01] and setting the excessive error warning trigger level in [Pr. PC38]. 0: 1 rev unit 1: 0.1 rev unit 2: 0.01 rev unit 3: 0.001 rev unit	0h	
PC26	Function selection C-5 Select [AL. 99 Stroke limit warning]. 0 0 0 x: [AL. 99 Stroke limit warning] selection 0: Enabled 1: Disabled When "1" is set, Warning [AL. 99] does not occur even if Forward rotation stroke end (LSP) or Reverse rotation stroke end (LSN) is turned off.	0000h	PC19	Function selection C-6 ___x: [AL. 99 Stroke limit warning] selection Enable or disable [AL. 99 Stroke limit warning]. 0: Enabled 1: Disabled When "Disabled" is selected, [AL. 99] does not occur while LSP (Forward rotation stroke end) or LSN (Reverse rotation stroke end) is off, but the operation will be stopped with the stroke limit.	0h	CP PS SP
				__x_: For manufacturer setting	0h	
				x: For manufacturer setting	0h	
				x___: For manufacturer setting	0h	



Part 7: Review on Replacement of MR-J3-_T_ (CC-Link communication operation) with MR-J4-_GF_

MR-J3-_T_			MR-J4-_GF_			Control mode																			
No.	Name and function	Initial value	No.	Name and function	Initial value																				
PC27	Function selection C-6 Set this when an undervoltage alarm occurs due to power supply distortion while the power regeneration converter or the power regeneration common converter is being used. 0 0 0 x: Control circuit power supply undervoltage alarm detection method selection 0: Initial value 1: Set this to "1" when an undervoltage alarm occurs due to power supply distortion while the power regeneration converter or the power regeneration common converter is being used.	0000h	PC20	Function selection C-7 ___ x: [AL. 10 Undervoltage] detection method selection Set this if [AL. 10 Undervoltage] occurs due to power supply voltage distortion while the FR-RC-(H), FR-CV-(H), or FR-XC-(H) is being used. 0: [AL. 10] not occurring 1: [AL. 10] occurring	0h	CP PS SP																			
				__ x _: For manufacturer setting	0h																				
				_ x _ _: Undervoltage alarm selection Select the alarm or warning that occurs when the bus voltage drops to the undervoltage alarm trigger level. 0: [AL. 10 Undervoltage] occurs regardless of servo motor speed. 1: [AL. E9 Main circuit off warning] occurs when the servo motor speed is 50 r/min (50 mm/s) or less, and [AL. 10] occurs when over 50 r/min (50 mm/s).	0h	CP PS SP																			
PC28	Function selection C-7 Select the display method of the current position/command position. 0 0 _ x: Electronic gear fraction clear selection 0: Disabled 1: Enabled When "1" is set, the fraction of the previous command given by the electronic gear is cleared when automatic operation starts. 0 0 x _: Current position/command position display selection	0000h	PT26	Function selection T-2 ___ x: Electronic gear fraction clear selection 0: Disabled 1: Enabled When "Valid" is selected, the fraction of the previous command given by the electronic gear is cleared when automatic operation starts. If "2" or more is set for this digit, this parameter will be set to "Disabled".	0h	CP																			
				Current position/command position display selection __ x _: Select the display method of the current position and command position. 0: Positioning display 1: Roll feed display	0h	CP																			
				<table border="1"> <thead> <tr> <th rowspan="2">Setting value</th> <th rowspan="2">Display method</th> <th rowspan="2">Operation mode</th> <th colspan="2">Status display details</th> </tr> <tr> <th>Current position</th> <th>Command position</th> </tr> </thead> <tbody> <tr> <td rowspan="2">0</td> <td rowspan="2">Positioning display</td> <td>Automatic</td> <td>Displays the current position with the machine home position as 0.</td> <td>Displays the command current position with the machine home position as 0.</td> </tr> <tr> <td>Manual</td> <td></td> <td></td> </tr> <tr> <td rowspan="3">1</td> <td rowspan="3">Roll feed display</td> <td rowspan="2">Automatic</td> <td>Displays the actual current position with the automatic operation start position as 0.</td> <td>Displays the command current position from the point where the operation signal is turned on and the count is started from 0 to when the target position is reached. At stopped state, the command position of the selected point table is displayed.</td> </tr> <tr> <td>Manual</td> <td>Displays the current position with the machine home position as 0.</td> <td>Always displays 0.</td> </tr> </tbody> </table>	Setting value	Display method	Operation mode	Status display details		Current position	Command position	0	Positioning display	Automatic	Displays the current position with the machine home position as 0.	Displays the command current position with the machine home position as 0.	Manual			1	Roll feed display	Automatic	Displays the actual current position with the automatic operation start position as 0.	Displays the command current position from the point where the operation signal is turned on and the count is started from 0 to when the target position is reached. At stopped state, the command position of the selected point table is displayed.	Manual
Setting value	Display method	Operation mode	Status display details																						
			Current position	Command position																					
0	Positioning display	Automatic	Displays the current position with the machine home position as 0.	Displays the command current position with the machine home position as 0.																					
		Manual																							
1	Roll feed display	Automatic	Displays the actual current position with the automatic operation start position as 0.	Displays the command current position from the point where the operation signal is turned on and the count is started from 0 to when the target position is reached. At stopped state, the command position of the selected point table is displayed.																					
			Manual	Displays the current position with the machine home position as 0.	Always displays 0.																				
		<table border="1"> <thead> <tr> <th rowspan="2">Setting value</th> <th rowspan="2">Display method</th> <th rowspan="2">Operation mode</th> <th colspan="2">Status display details</th> </tr> <tr> <th>Current position</th> <th>Command position</th> </tr> </thead> <tbody> <tr> <td rowspan="2">__ 0 _</td> <td rowspan="2">Positioning display</td> <td colspan="2">Automatic/manual</td> <td>Displays the current position with the machine home position as 0.</td> <td>Displays the command current position with the machine home position as 0.</td> </tr> <tr> <td rowspan="3">Automatic</td> <td>Continuous positioning operation</td> <td>Not available.</td> <td>Not available.</td> </tr> <tr> <td>Single positioning operation</td> <td>Displays the current position with the automatic operation start position as 0.</td> <td>Displays the command current position from the point where the operation signal is turned on and the count is started from 0 to when the target position is reached. At stopped state, the command position is displayed. (When the positioning mode is the point table method, the target position of the point table is displayed.)</td> </tr> <tr> <td>Manual</td> <td>Displays the current position with the machine home position as 0.</td> <td>Always displays 0.</td> </tr> </tbody> </table>	Setting value	Display method	Operation mode	Status display details		Current position	Command position	__ 0 _	Positioning display	Automatic/manual		Displays the current position with the machine home position as 0.	Displays the command current position with the machine home position as 0.	Automatic	Continuous positioning operation	Not available.	Not available.	Single positioning operation	Displays the current position with the automatic operation start position as 0.	Displays the command current position from the point where the operation signal is turned on and the count is started from 0 to when the target position is reached. At stopped state, the command position is displayed. (When the positioning mode is the point table method, the target position of the point table is displayed.)	Manual	Displays the current position with the machine home position as 0.	Always displays 0.
Setting value	Display method	Operation mode				Status display details																			
			Current position	Command position																					
__ 0 _	Positioning display	Automatic/manual		Displays the current position with the machine home position as 0.	Displays the command current position with the machine home position as 0.																				
		Automatic	Continuous positioning operation	Not available.	Not available.																				
Single positioning operation	Displays the current position with the automatic operation start position as 0.		Displays the command current position from the point where the operation signal is turned on and the count is started from 0 to when the target position is reached. At stopped state, the command position is displayed. (When the positioning mode is the point table method, the target position of the point table is displayed.)																						
Manual	Displays the current position with the machine home position as 0.		Always displays 0.																						
				_ x _ _: For manufacturer setting	0h																				
				x _ _ _: For manufacturer setting	0h																				

Part 7: Review on Replacement of MR-J3-_T_ (CC-Link communication operation) with MR-J4-_GF_

MR-J3-_T_			MR-J4-_GF_																											
No.	Name and function	Initial value	No.	Name and function	Initial value	Control mode																								
PC30	<p>Remote register-based position/speed specifying method selection</p> <p>This parameter is enabled when the position/speed specifying method selection (RY (n + 2) A) is turned on when two stations are occupied.</p> <p>0 __ x:</p> <p>Select the method by which the position command and speed command for point table positioning operation are received.</p> <p>If "1" or "2" is selected when one station is occupied, a parameter error will occur.</p> <table border="1"> <thead> <tr> <th>Setting value</th> <th>Position command</th> <th>Speed command</th> </tr> </thead> <tbody> <tr> <td>0</td> <td>Specify the point table No.</td> <td></td> </tr> <tr> <td>1</td> <td>Specify the position data.</td> <td>Specify the point table No.</td> </tr> <tr> <td>2</td> <td></td> <td>Specify the servo motor speed.</td> </tr> </tbody> </table> <p>When "2" is set and operating with the speed command, always set the acceleration/deceleration time constants to point table No. 1.</p>	Setting value	Position command	Speed command	0	Specify the point table No.		1	Specify the position data.	Specify the point table No.	2		Specify the servo motor speed.	0h	PT62	<p>Remote register-based position/speed specifying method selection</p> <p>__ x:</p> <p>Position/speed specifying method selection of point table method</p> <table border="1"> <thead> <tr> <th>Setting value</th> <th>Position command</th> <th>Speed command</th> </tr> </thead> <tbody> <tr> <td>0</td> <td>Point table number</td> <td>Point table number</td> </tr> <tr> <td>1</td> <td>Position data</td> <td>Point table number</td> </tr> <tr> <td>2</td> <td></td> <td>Servo motor speed</td> </tr> </tbody> </table> <p>When "2" is set and operating with the speed command, always set the acceleration/deceleration time constants to point table No. 1.</p>	Setting value	Position command	Speed command	0	Point table number	Point table number	1	Position data	Point table number	2		Servo motor speed	0h	CP
	Setting value	Position command	Speed command																											
	0	Specify the point table No.																												
1	Specify the position data.	Specify the point table No.																												
2		Specify the servo motor speed.																												
Setting value	Position command	Speed command																												
0	Point table number	Point table number																												
1	Position data	Point table number																												
2		Servo motor speed																												
<p>0 _ x _:</p> <p>Select the method by which the position command and speed command for indexer positioning operation are received.</p> <p>If "1" s selected when one station is occupied, a parameter error will occur.</p> <table border="1"> <thead> <tr> <th>Setting value</th> <th>Position command</th> <th>Speed command</th> </tr> </thead> <tbody> <tr> <td>0</td> <td>Specify the station No.</td> <td>Specify the point table No.</td> </tr> <tr> <td>1</td> <td></td> <td>Specify the servo motor speed.</td> </tr> </tbody> </table> <p>When "1" is set and operating with the speed command, always set the acceleration/deceleration time constants to point table No. 1.</p>	Setting value	Position command	Speed command	0	Specify the station No.	Specify the point table No.	1		Specify the servo motor speed.	0h	<p>_ _ x _:</p> <p>Position/speed specifying method selection of indexer method</p> <table border="1"> <thead> <tr> <th>Setting value</th> <th>Position command</th> <th>Speed command</th> </tr> </thead> <tbody> <tr> <td>0</td> <td>Next station number</td> <td>Point table number</td> </tr> <tr> <td>1</td> <td></td> <td>Servo motor speed</td> </tr> </tbody> </table> <p>When "1" is set and operating with the speed command, always set the acceleration/deceleration time constants to point table No. 1.</p>	Setting value	Position command	Speed command	0	Next station number	Point table number	1		Servo motor speed	0h	PS								
Setting value	Position command	Speed command																												
0	Specify the station No.	Specify the point table No.																												
1		Specify the servo motor speed.																												
Setting value	Position command	Speed command																												
0	Next station number	Point table number																												
1		Servo motor speed																												
<p>0 x __:</p> <p>Select the method by which the speed command for speed control operation is received.</p> <p>If "1" s selected when one station is occupied, a parameter error will occur.</p> <table border="1"> <thead> <tr> <th>Setting value</th> <th>Speed command</th> </tr> </thead> <tbody> <tr> <td>0</td> <td>Specify the speed selection number.</td> </tr> <tr> <td>1</td> <td>Specify the servo motor speed.</td> </tr> </tbody> </table>	Setting value	Speed command	0	Specify the speed selection number.	1	Specify the servo motor speed.	0h	<p>_ x __:</p> <p>Speed specifying method selection of speed control mode (point table) method</p> <table border="1"> <thead> <tr> <th>Setting value</th> <th>Speed command</th> </tr> </thead> <tbody> <tr> <td>0</td> <td>Specify the speed selection number.</td> </tr> <tr> <td>1</td> <td>Specify the servo motor speed command (unsigned).</td> </tr> </tbody> </table> <p>When "1" is set, always set the acceleration/deceleration time constants to point table No. 1 or point table No. 2. The servo motor speed is limited by the permissible speed of the servo motor.</p>	Setting value	Speed command	0	Specify the speed selection number.	1	Specify the servo motor speed command (unsigned).	0h	SP														
Setting value	Speed command																													
0	Specify the speed selection number.																													
1	Specify the servo motor speed.																													
Setting value	Speed command																													
0	Specify the speed selection number.																													
1	Specify the servo motor speed command (unsigned).																													
PC50	<p>Function selection C-A</p> <p>_ 0 0 x:</p> <p>Remote register speed command data reflection timing selection</p> <p>Select the timing in which to reflect the speed command data of the remote register.</p> <p>0: Reflected at the rising edge of the speed command execution request (RY (n + 2) 1).</p> <p>1: Always reflected while the speed command execution request (RY (n + 2) 1) is on.</p>	0000h	<p>x _ _:</p> <p>Speed command data reflection timing selection of speed control mode (point table) method</p> <p>0: Reflected at the edge while the speed command execution demand is on.</p> <p>1: Always reflected while the speed command execution demand is on.</p>	0h	SP																									

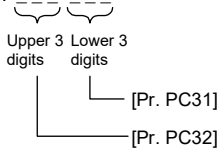
Part 7: Review on Replacement of MR-J3-_T_ (CC-Link communication operation) with MR-J4-_GF_

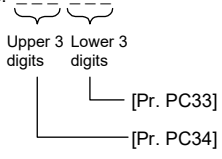
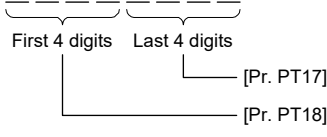
MR-J3-_T_			MR-J4-_GF_				
No.	Name and function	Initial value	No.	Name and function	Initial value	Control mode	
PC31	Software limit +	0	PT15	Software limit + (last 4 digits)	0000h	CP	
PC32	<p>Set the address increasing side of the software stroke limit. If the same value as "Software limit -" is set, the software limit will be disabled.</p> <p>Set the same sign for [Pr. PC31]/[Pr. PC32]. Setting a different sign will result in a parameter error.</p> <p>Set address:</p>  <p>The upper and lower digits of Software limit + are combined to make one set. When changing the digits, change the lower digit first before changing the upper digit.</p>	0	PT16	<p>Software limit + (first 4 digits)</p> <p>Set the address increasing side of the software stroke limit. The upper and lower digits are combined to make one set.</p> <p>Setting address:</p>  <p>If a value equal to or greater than that of "Software limit +" is set to "Software limit -", the software limit will be disabled.</p> <p>When changing the setting of this parameter with MR Configurator2, do so in the servo-off state or in the home position return mode.</p> <p>Setting range: 8000 0000h to 7FFF FFFFh (-2147483648 to 2147483647)</p>	0000h		
PC33	Software limit -	0	PT17	Software limit - (last 4 digits)	0000h	CP	
PC34	<p>Sets the address decreasing side of the software stroke limit. If the same value as "Software limit +" is set, the software limit will be disabled.</p> <p>Set the same sign for [Pr. PC33]/[Pr. PC34]. Setting a different sign will result in a parameter error.</p> <p>Set address:</p>  <p>The upper and lower digits of Software limit - are combined to make one set. When changing the digits, change the lower digit first before changing the upper digit.</p>	0	PT18	<p>Software limit - (first 4 digits)</p> <p>Set the address decreasing side of the software stroke limit. The upper and lower digits are combined to make one set.</p> <p>Setting address:</p>  <p>If a value equal to or greater than that of "Software limit +" is set to "Software limit -", the software limit will be disabled.</p> <p>When changing the setting of this parameter with MR Configurator2, do so in the servo-off state or in the home position return mode.</p> <p>Setting range: 8000 0000h to 7FFF FFFFh (-2147483648 to 2147483647)</p>	0000h		
PC35	Internal torque limit 2	100.0	PC77	<p>Internal torque limit 2</p> <p>Set the servo parameter to limit the torque of the servo motor. Set the rated torque at 100.0%. If this object is set to "0.0", the servo motor does not generate torque.</p> <p>This parameter setting is enabled while automatic operation, manual operation, and homing operation are stopped. During operation, the setting values of [Pr. PA11] and [Pr. PA12] are enabled.</p> <p>Setting range: 0.0 to 1000.0</p>	0.0	CP PS SP	
			PT48	<p>Function selection T-7A</p> <p>__x:</p> <p>Torque limit selection during stop</p> <p>0: Disabled</p> <p>1: Enabled</p> <p>When "0" is set, [Pr. PC77] is enabled for the torque limit value for stopping the indexer operation. When "1" is set, [Pr. PC77], [Pr. PA11], and [Pr. PA12] are compared and the one with the lowest value is enabled for the torque limit value for stopping the indexer operation.</p>	0h		PS
				__x_:	0h		
				x:	0h		
				x_:	0h		

Part 7: Review on Replacement of MR-J3-_T_ (CC-Link communication operation) with MR-J4-_GF_

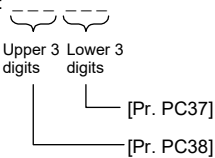
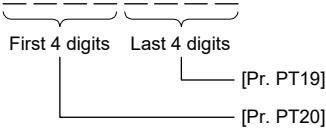
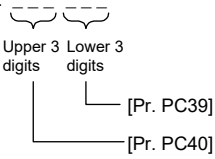
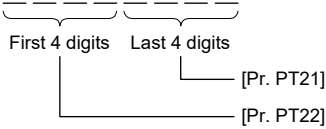
MR-J3-_T_			MR-J4-_GF_																			
No.	Name and function	Initial value	No.	Name and function	Initial value	Control mode																
PC37 PC38	<p>Position range output address +</p> <p>Set the address increasing side of the position range output address.</p> <p>Set the same sign for [Pr. PC37]/[Pr. PC38]. Setting a different sign will result in a parameter error.</p> <p>Use [Pr. PC37] to [Pr. PC40] to set the range where position range (POT) turns on.</p> <p>Set address:</p>  <p>The upper and lower digits of Position range output address + are combined to make one set. When changing the digits, change the lower digit first before changing the upper digit.</p>	0	PT19 PT20	<p>Position range output address + (last 4 digits)</p> <p>Position range output address + (first 4 digits)</p> <p>Set the address increasing side of the position range output address. The upper and lower digits are combined to make one set.</p> <p>Use [Pr. PT19] to [Pr. PT22] to set the range where RXnE (Position range) turns on.</p> <p>Setting address:</p>  <p>Setting range: 8000 0000h to 7FFF FFFFh (-2147483648 to 2147483647)</p>	0000h 0000h	CP																
PC39 PC40	<p>Position range output address -</p> <p>Set the address decreasing side of the position range output address.</p> <p>Set the same sign for [Pr. PC39]/[Pr. PC40]. Setting a different sign will result in a parameter error.</p> <p>Set address:</p>  <p>The upper and lower digits of Position range output address - are combined to make one set. When changing the digits, change the lower digit first before changing the upper digit.</p>	0	PT21 PT22	<p>Position range output address - (last 4 digits)</p> <p>Position range output address - (first 4 digits)</p> <p>Set the address decreasing side of the position range output address.</p> <p>The upper and lower digits are combined to make one set.</p> <p>Use [Pr. PT19] to [Pr. PT22] to set the range where RXnE (Position range) turns on.</p> <p>Setting address:</p>  <p>Setting range: 8000 0000h to 7FFF FFFFh (-2147483648 to 2147483647)</p>	0000h 0000h	CP																
PC45	<p>Function selection C-9</p> <p>0 0 0 x:</p> <p>Selection of manual operation mode for indexer positioning operation</p> <p>Select the manual operation mode.</p> <p>0: Indexer JOG operation</p> <p>1: JOG operation</p>	0000h	PT27	<p>Indexer method - Operation mode selection</p> <p>___ x:</p> <p>For manufacturer setting</p> <p>__ x _:</p> <p>Manual operation method selection</p> <p>0: Station JOG operation</p> <p>1: JOG operation</p> <p>_ x _:</p> <p>For manufacturer setting</p> <p>x ___:</p> <p>For manufacturer setting</p>	0h 0h 0h 0h	PS																
PC46	<p>Number of stations/rotation for indexer positioning operation</p> <p>Set the number of stations (number of indexers) per rotation of the machine. If the setting value is 2 or less, the number of stations will be 2.</p> <table border="1" data-bbox="236 1771 528 1944"> <thead> <tr> <th>Setting value</th> <th>Number of stations</th> </tr> </thead> <tbody> <tr><td>0000</td><td>2</td></tr> <tr><td>0001</td><td>2</td></tr> <tr><td>0002</td><td>2</td></tr> <tr><td>0003</td><td>3</td></tr> <tr><td>0004</td><td>4</td></tr> <tr><td>⋮</td><td>⋮</td></tr> <tr><td>00FF</td><td>255</td></tr> </tbody> </table>	Setting value	Number of stations	0000	2	0001	2	0002	2	0003	3	0004	4	⋮	⋮	00FF	255	0000h	PT28	<p>Number of stations per rotation</p> <p>Set the number of stations (number of indexer stations) per rotation of the machine.</p> <p>If the setting value is "0" or "1", the number of stations will be 2.</p> <p>Setting range: 0 to 255</p>	8	PS
Setting value	Number of stations																					
0000	2																					
0001	2																					
0002	2																					
0003	3																					
0004	4																					
⋮	⋮																					
00FF	255																					

Part 7: Review on Replacement of MR-J3-_T_ (CC-Link communication operation) with MR-J4-_GF_

MR-J3-_T_			MR-J4-_GF_			Control mode
No.	Name and function	Initial value	No.	Name and function	Initial value	
PC47	<p>Station home position shift distance for indexer positioning operation</p> <p>This parameter is not available in the absolute position detection system.</p> <p>Use the number of pulses to set the amount by which to shift the home position with respect to the position set as the home position with this parameter.</p> <p>This shift amount is not enabled immediately after setting the home position. It is enabled when the power is cycled.</p> <p>If the shift distance is longer than the in-position range, In-position (RXn1) will not turn on at power-on.</p> <p>Convert the number of pulses to be shifted to hexadecimal before setting.</p> <p>The setting range is -2000 to 2000 pulses.</p>	0000h	PT40	<p>Station home position shift distance</p> <p>When homing, set the station home position shift distance in units of encoder pulses.</p> <p>By setting this parameter, the station home position (station number 0) can be shifted with respect to the homing position.</p> <p>The following shows the precautions on setting the station home position shift distance.</p> <ul style="list-style-type: none"> ▪ During homing, the station home position shift setting is disabled. It is enabled when the power is cycled. ▪ If the station home position shift distance is larger than the in-position range, RXn1 (In-position) is not turned on when the power is cycled after homing. <p>Setting range: -32000 to 32000</p>	0	PS
PC50	<p>Function selection C-A</p> <p>x 0 0 _:</p> <p>CC-Link communication error (A8D) extension function selection</p> <p>0: No extension</p> <p>1: CC-Link communication error (A8D) detection delay</p> <p>The time in which CC-Link communication error (A8D) occurrence is waited can be adjusted with [Pr. PD25].</p>	0000h		<p>No corresponding parameter</p> <p>CC-Link IE communication error (AL.8D) is detected in the initial state.</p> <p>The time in which to detect CC-Link IE communication error (AL.8D) can be adjusted with [Pr. PN02].</p> <p>For details, refer to "MR-J4-_GF_(-RJ) Servo Amplifier Instruction Manual (Motion Mode)".</p>		CP PS SP

Part 7: Review on Replacement of MR-J3-_T_ (CC-Link communication operation) with MR-J4-_GF_

MR-J3-_T_			MR-J4-_GF_			Control mode																								
No.	Name and function	Initial value	No.	Name and function	Initial value																									
PD01	Input signal automatic ON selection 1 Select input devices that turn on automatically. ☐ : Indicates that this is for manufacturer setting. Configuration is not allowed.	0000h	PD01	Input signal automatic ON selection 1 Select input devices that turn on automatically.	0h																									
				<table border="1"> <thead> <tr> <th rowspan="2">Device name</th> <th colspan="2">Initial value</th> </tr> <tr> <th>BIN</th> <th>HEX</th> </tr> </thead> <tbody> <tr> <td>Servo-on (SON)</td> <td>0</td> <td>0</td> </tr> <tr> <td>Proportional control (PC)</td> <td>0</td> <td>0</td> </tr> <tr> <td>External torque limit selection (TL)</td> <td>0</td> <td>0</td> </tr> <tr> <td>LSP (Forward rotation stroke end)</td> <td>0</td> <td>0</td> </tr> <tr> <td>LSN (Reverse rotation stroke end)</td> <td>0</td> <td>0</td> </tr> <tr> <td>Forced stop (EMG)</td> <td>0</td> <td>0</td> </tr> </tbody> </table> <p>BIN 0: Use for an external input signal BIN 1: Automatic ON</p>			Device name	Initial value		BIN	HEX	Servo-on (SON)	0	0	Proportional control (PC)	0	0	External torque limit selection (TL)	0	0	LSP (Forward rotation stroke end)	0	0	LSN (Reverse rotation stroke end)	0	0	Forced stop (EMG)	0	0	
Device name	Initial value																													
	BIN	HEX																												
Servo-on (SON)	0	0																												
Proportional control (PC)	0	0																												
External torque limit selection (TL)	0	0																												
LSP (Forward rotation stroke end)	0	0																												
LSN (Reverse rotation stroke end)	0	0																												
Forced stop (EMG)	0	0																												
	For example, when Servo-on (RYn0) is turned on the setting value is "___4".			<table border="1"> <thead> <tr> <th rowspan="2">Signal name</th> <th colspan="2">Initial value</th> </tr> <tr> <th>BIN</th> <th>HEX</th> </tr> </thead> <tbody> <tr> <td>LSP (Forward rotation stroke end)</td> <td>0</td> <td>0</td> </tr> <tr> <td>LSN (Reverse rotation stroke end)</td> <td>0</td> <td>0</td> </tr> </tbody> </table> <p>BIN 0: Use for an external input signal BIN 1: Automatic ON</p>	Signal name	Initial value		BIN	HEX	LSP (Forward rotation stroke end)	0	0	LSN (Reverse rotation stroke end)	0	0															
Signal name	Initial value																													
	BIN	HEX																												
LSP (Forward rotation stroke end)	0	0																												
LSN (Reverse rotation stroke end)	0	0																												
			PA04	Function selection A-1																										
				<table border="1"> <thead> <tr> <th>Setting value</th> <th>EM1/EM2</th> <th colspan="2">Deceleration method</th> </tr> <tr> <th></th> <th></th> <th>EM2 or EM1 is off</th> <th>Alarm occurrence</th> </tr> </thead> <tbody> <tr> <td>0 0 __</td> <td>EM1</td> <td>MBR (Electromagnetic brake interlock) turns off without the forced stop deceleration.</td> <td>MBR (Electromagnetic brake interlock) turns off without the forced stop deceleration.</td> </tr> <tr> <td>2 0 __</td> <td>EM2</td> <td>MBR (Electromagnetic brake interlock) turns off after the forced stop deceleration.</td> <td>MBR (Electromagnetic brake interlock) turns off after the forced stop deceleration.</td> </tr> <tr> <td>0 1 __</td> <td>Neither EM2 nor EM1 is used.</td> <td></td> <td>MBR (Electromagnetic brake interlock) turns off without the forced stop deceleration.</td> </tr> <tr> <td>2 1 __</td> <td>Neither EM2 nor EM1 is used.</td> <td></td> <td>MBR (Electromagnetic brake interlock) turns off after the forced stop deceleration.</td> </tr> </tbody> </table>	Setting value	EM1/EM2	Deceleration method				EM2 or EM1 is off	Alarm occurrence	0 0 __	EM1	MBR (Electromagnetic brake interlock) turns off without the forced stop deceleration.	MBR (Electromagnetic brake interlock) turns off without the forced stop deceleration.	2 0 __	EM2	MBR (Electromagnetic brake interlock) turns off after the forced stop deceleration.	MBR (Electromagnetic brake interlock) turns off after the forced stop deceleration.	0 1 __	Neither EM2 nor EM1 is used.		MBR (Electromagnetic brake interlock) turns off without the forced stop deceleration.	2 1 __	Neither EM2 nor EM1 is used.		MBR (Electromagnetic brake interlock) turns off after the forced stop deceleration.		
Setting value	EM1/EM2	Deceleration method																												
		EM2 or EM1 is off	Alarm occurrence																											
0 0 __	EM1	MBR (Electromagnetic brake interlock) turns off without the forced stop deceleration.	MBR (Electromagnetic brake interlock) turns off without the forced stop deceleration.																											
2 0 __	EM2	MBR (Electromagnetic brake interlock) turns off after the forced stop deceleration.	MBR (Electromagnetic brake interlock) turns off after the forced stop deceleration.																											
0 1 __	Neither EM2 nor EM1 is used.		MBR (Electromagnetic brake interlock) turns off without the forced stop deceleration.																											
2 1 __	Neither EM2 nor EM1 is used.		MBR (Electromagnetic brake interlock) turns off after the forced stop deceleration.																											

Part 7: Review on Replacement of MR-J3-_T_ (CC-Link communication operation) with MR-J4-_GF_

MR-J3-_T_			MR-J4-_GF_			Control mode
No.	Name and function	Initial value	No.	Name and function	Initial value	
PD01	Input signal automatic ON selection 1 Select input devices that turn on automatically. ☒ : Indicates that this is for manufacturer setting. Configuration is not allowed.	0000h	PB24	Slight vibration suppression control ___x: Slight vibration suppression control selection Select the slight vibration suppression control. 0: Disabled 1: Enabled The slight vibration suppression control is enabled when "Manual mode (___3)" is selected for "Gain adjustment mode selection" in [Pr. PA08]. Slight vibration suppression control selection cannot be used in speed control mode (point table method).	0h	CP PS
				PI-PID switching control selection 0: PI control enabled ___x_ (Switching to PID control (proportional control) is enabled by PID switching signal from controller and the input device PC (proportional control).) 3: PID control (proportional control) is always enabled. If the servo motor at a stop is rotated even for a pulse due to any external factor, it generates torque to compensate for a position mismatch. When the servo motor shaft is to be locked mechanically after positioning completion (stop), enabling the PID control and completing positioning simultaneously will suppress the unnecessary torque generated to compensate for a position mismatch.	0h	CP PS SP
				_x__: For manufacturer setting	0h	
				x___: For manufacturer setting	0h	

Part 7: Review on Replacement of MR-J3-_T_ (CC-Link communication operation) with MR-J4-_GF_

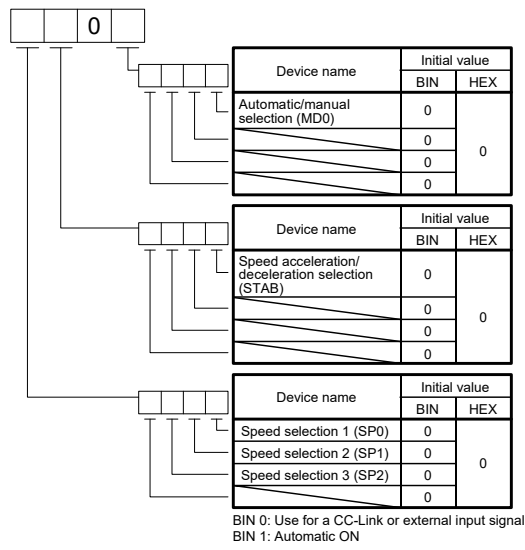
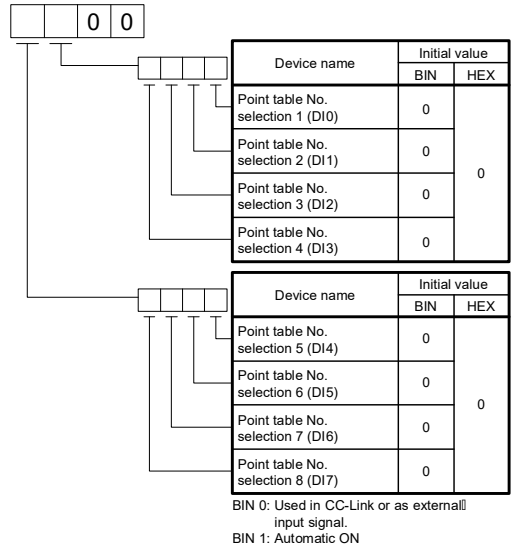
MR-J3-_T_			MR-J4-_GF_			Control mode																																										
No.	Name and function	Initial value	No.	Name and function	Initial value																																											
PD03	<p>Input signal automatic ON selection 3 Select input devices that turn on automatically. ☐ : Indicates that this is for manufacturer setting. Configuration is not allowed.</p>  <table border="1" data-bbox="454 492 742 638"> <thead> <tr> <th rowspan="2">Device name</th> <th colspan="2">Initial value</th> </tr> <tr> <th>BIN</th> <th>HEX</th> </tr> </thead> <tbody> <tr> <td>Automatic/manual selection (MD0)</td> <td>0</td> <td rowspan="4">0</td> </tr> <tr> <td></td> <td>0</td> </tr> <tr> <td></td> <td>0</td> </tr> <tr> <td></td> <td>0</td> </tr> </tbody> </table> <table border="1" data-bbox="454 649 742 806"> <thead> <tr> <th rowspan="2">Device name</th> <th colspan="2">Initial value</th> </tr> <tr> <th>BIN</th> <th>HEX</th> </tr> </thead> <tbody> <tr> <td>Speed acceleration/deceleration selection (STAB)</td> <td>0</td> <td rowspan="4">0</td> </tr> <tr> <td></td> <td>0</td> </tr> <tr> <td></td> <td>0</td> </tr> <tr> <td></td> <td>0</td> </tr> </tbody> </table> <table border="1" data-bbox="454 817 742 952"> <thead> <tr> <th rowspan="2">Device name</th> <th colspan="2">Initial value</th> </tr> <tr> <th>BIN</th> <th>HEX</th> </tr> </thead> <tbody> <tr> <td>Speed selection 1 (SP0)</td> <td>0</td> <td rowspan="4">0</td> </tr> <tr> <td>Speed selection 2 (SP1)</td> <td>0</td> </tr> <tr> <td>Speed selection 3 (SP2)</td> <td>0</td> </tr> <tr> <td></td> <td>0</td> </tr> </tbody> </table> <p>BIN 0: Use for a CC-Link or external input signal BIN 1: Automatic ON</p>	Device name	Initial value		BIN	HEX	Automatic/manual selection (MD0)	0	0		0		0		0	Device name	Initial value		BIN	HEX	Speed acceleration/deceleration selection (STAB)	0	0		0		0		0	Device name	Initial value		BIN	HEX	Speed selection 1 (SP0)	0	0	Speed selection 2 (SP1)	0	Speed selection 3 (SP2)	0		0	0000h		No corresponding parameter		
Device name	Initial value																																															
	BIN	HEX																																														
Automatic/manual selection (MD0)	0	0																																														
	0																																															
	0																																															
	0																																															
Device name	Initial value																																															
	BIN	HEX																																														
Speed acceleration/deceleration selection (STAB)	0	0																																														
	0																																															
	0																																															
	0																																															
Device name	Initial value																																															
	BIN	HEX																																														
Speed selection 1 (SP0)	0	0																																														
Speed selection 2 (SP1)	0																																															
Speed selection 3 (SP2)	0																																															
	0																																															
PD04	<p>Input signal automatic ON selection 4 Select input devices that turn on automatically.</p>  <table border="1" data-bbox="454 1142 742 1366"> <thead> <tr> <th rowspan="2">Device name</th> <th colspan="2">Initial value</th> </tr> <tr> <th>BIN</th> <th>HEX</th> </tr> </thead> <tbody> <tr> <td>Point table No. selection 1 (DI0)</td> <td>0</td> <td rowspan="4">0</td> </tr> <tr> <td>Point table No. selection 2 (DI1)</td> <td>0</td> </tr> <tr> <td>Point table No. selection 3 (DI2)</td> <td>0</td> </tr> <tr> <td>Point table No. selection 4 (DI3)</td> <td>0</td> </tr> </tbody> </table> <table border="1" data-bbox="454 1377 742 1601"> <thead> <tr> <th rowspan="2">Device name</th> <th colspan="2">Initial value</th> </tr> <tr> <th>BIN</th> <th>HEX</th> </tr> </thead> <tbody> <tr> <td>Point table No. selection 5 (DI4)</td> <td>0</td> <td rowspan="4">0</td> </tr> <tr> <td>Point table No. selection 6 (DI5)</td> <td>0</td> </tr> <tr> <td>Point table No. selection 7 (DI6)</td> <td>0</td> </tr> <tr> <td>Point table No. selection 8 (DI7)</td> <td>0</td> </tr> </tbody> </table> <p>BIN 0: Used in CC-Link or as external input signal. BIN 1: Automatic ON</p>	Device name	Initial value		BIN	HEX	Point table No. selection 1 (DI0)	0	0	Point table No. selection 2 (DI1)	0	Point table No. selection 3 (DI2)	0	Point table No. selection 4 (DI3)	0	Device name	Initial value		BIN	HEX	Point table No. selection 5 (DI4)	0	0	Point table No. selection 6 (DI5)	0	Point table No. selection 7 (DI6)	0	Point table No. selection 8 (DI7)	0	0000h		No corresponding parameter																
Device name	Initial value																																															
	BIN	HEX																																														
Point table No. selection 1 (DI0)	0	0																																														
Point table No. selection 2 (DI1)	0																																															
Point table No. selection 3 (DI2)	0																																															
Point table No. selection 4 (DI3)	0																																															
Device name	Initial value																																															
	BIN	HEX																																														
Point table No. selection 5 (DI4)	0	0																																														
Point table No. selection 6 (DI5)	0																																															
Point table No. selection 7 (DI6)	0																																															
Point table No. selection 8 (DI7)	0																																															

Part 7: Review on Replacement of MR-J3-_T_ (CC-Link communication operation) with MR-J4-_GF_

MR-J3-_T_			MR-J4-_GF_																							
No.	Name and function	Initial value	No.	Name and function	Initial value	Control mode																				
PD06	Input signal device selection 2 (CN6-2) Any input device can be assigned to the CN6-2 pin. 0 0 x x: Select the CN6-2 pin input device. 0 0: No assigned function 0 2: Servo-on (SON) 0 3: Reset (RES) 0 4: Proportional control (PC) 0 6: Clear (CR) 0 7: Forward rotation start (ST1) 0 8: Reverse rotation start (ST2) 0 9: Internal torque limit selection (TL2) 0 A: Forward rotation stroke end (LSP) 0 B: Reverse rotation stroke end (LSN) 0 D: Gain switching (CDP) 2 0: Automatic/manual selection (MD0) 2 4: Manual pulse generator multiplication 1 (TP0) 2 5: Manual pulse generator multiplication 2 (TP1) 2 7: Temporary stop/restart (TSTP) 2 B: Proximity dog (DOG) Note. The setting values other than those shown here are for manufacturer settings. Configuration is not allowed.	002Bh	PD03	Input device selection 1 Any input device can be assigned to the CN3-2 pin.	0Ah	CP																				
				Device selection __ x x: Refer to the following table for setting values.		PS																				
				_ x __: For manufacturer setting		SP																				
				x ___: For manufacturer setting																						
			<table border="1"> <thead> <tr> <th>Setting value</th> <th>Input device</th> </tr> </thead> <tbody> <tr> <td>__ 0 0</td> <td></td> </tr> <tr> <td>__ 0 3</td> <td>RES (Reset)</td> </tr> <tr> <td>__ 0 4</td> <td>PC (Proportional control)</td> </tr> <tr> <td>__ 0 6</td> <td>CR (Clear)</td> </tr> <tr> <td>__ 0 9</td> <td>CTL (Internal torque limit selection)</td> </tr> <tr> <td>__ 0 A</td> <td>LSP (Forward rotation stroke end)</td> </tr> <tr> <td>__ 0 B</td> <td>LSN (Reverse rotation stroke end)</td> </tr> <tr> <td>__ 0 D</td> <td>CDP (Gain switching)</td> </tr> <tr> <td>__ 2 2</td> <td>DOG (Proximity dog)</td> </tr> </tbody> </table>				Setting value	Input device	__ 0 0		__ 0 3	RES (Reset)	__ 0 4	PC (Proportional control)	__ 0 6	CR (Clear)	__ 0 9	CTL (Internal torque limit selection)	__ 0 A	LSP (Forward rotation stroke end)	__ 0 B	LSN (Reverse rotation stroke end)	__ 0 D	CDP (Gain switching)	__ 2 2	DOG (Proximity dog)
Setting value	Input device																									
__ 0 0																										
__ 0 3	RES (Reset)																									
__ 0 4	PC (Proportional control)																									
__ 0 6	CR (Clear)																									
__ 0 9	CTL (Internal torque limit selection)																									
__ 0 A	LSP (Forward rotation stroke end)																									
__ 0 B	LSN (Reverse rotation stroke end)																									
__ 0 D	CDP (Gain switching)																									
__ 2 2	DOG (Proximity dog)																									
PD07	Input signal device selection 3 (CN6-3) Any input device can be assigned to the CN6-3 pin. The devices that can be assigned and the setting method are the same as those for [Pr. PD06]. 0 0 x x: Select the CN6-3 pin input device.	000Ah	PD04	Input device selection 2 Any input device can be assigned to the CN3-12 pin.	22h	CP																				
				__ x x: Device selection Refer to the table of [Pr. PD03] for setting values.		PS																				
				_ x __: For manufacturer setting		SP																				
				x ___: For manufacturer setting																						
PD08	Input signal device selection 4 (CN6-4) Any input device can be assigned to the CN6-4 pin. The devices that can be assigned and the setting method are the same as those for [Pr. PD06]. 0 0 x x: Select the CN6-4 pin input device.	000Bh	PD05	Input device selection 3 Any input device can be assigned to the CN3-19 pin.	22h	CP																				
				__ x x: Device selection Refer to the table of [Pr. PD03] for setting values.		PS																				
				_ x __: For manufacturer setting		SP																				
				x ___: For manufacturer setting																						

Part 7: Review on Replacement of MR-J3-_T_ (CC-Link communication operation) with MR-J4-_GF_

MR-J3-_T_			MR-J4-_GF_																																									
No.	Name and function	Initial value	No.	Name and function	Initial value	Control mode																																						
PD09	<p>Output signal device selection 1 (CN6-14) Any output device can be assigned to the CN6-14 pin. RD is assigned as the initial value.</p> <p>0 0 x x: Select the CN6-14 pin output device.</p> <p>0 0: Always off 0 2: Ready (RD) 0 3: Malfunction (ALM) 0 4: In-position (INP) 0 5: Electromagnetic brake interlock (MBR) 0 6: Dynamic brake interlock (DB) 0 7: Limiting torque (TLC) 0 8: Warning (WNG) 0 9: Battery warning (BWNG) 0 A: Speed command reached (SA) 0 C: Zero speed detection (ZSP) 0 F: Variable gain selection (CDPS) 2 3: Rough match (CPO) 2 4: Home position return completion (ZP) 2 5: Position range (POT) 2 6: Temporarily stopped (PUS) 2 7: Travel completion (MEND) 3 8: Point table No. output 1 (PT0) 3 9: Point table No. output 2 (PT1) 3 A: Point table No. output 3 (PT2) 3 B: Point table No. output 4 (PT3) 3 C: Point table No. output 5 (PT4) 3 D: Point table No. output 6 (PT5) 3 E: Point table No. output 7 (PT6) 3 F: Point table No. output 8 (PT7)</p> <p>Note. The setting values other than those shown here are for manufacturer settings. Configuration is not allowed.</p>	0002h	PD07	<p>Output device selection 1 Any output device can be assigned to the CN3-13 pin. MBR (Electromagnetic brake interlock) is assigned as the initial value.</p> <p>__ x x: Device selection Refer to the following table for setting values.</p> <p>_ x __: For manufacturer setting</p> <p>x ___: For manufacturer setting</p>	05h	CP PS SP																																						
							0h	<table border="1"> <thead> <tr> <th>Setting value</th> <th>Output device</th> </tr> </thead> <tbody> <tr><td>__ 0 0</td><td>Always off</td></tr> <tr><td>__ 0 2</td><td>RD (Ready)</td></tr> <tr><td>__ 0 3</td><td>ALM (Malfunction)</td></tr> <tr><td>__ 0 4</td><td>INP (In-position)</td></tr> <tr><td>__ 0 5</td><td>MBR (Electromagnetic brake interlock)</td></tr> <tr><td>__ 0 6</td><td>DB (Dynamic brake interlock)</td></tr> <tr><td>__ 0 7</td><td>TLC (Limiting torque)</td></tr> <tr><td>__ 0 8</td><td>WNG (Warning)</td></tr> <tr><td>__ 0 9</td><td>BWNG (Battery warning)</td></tr> <tr><td>__ 0 A</td><td>SA (Speed reached)</td></tr> <tr><td>__ 0 C</td><td>ZSP (Zero speed detection)</td></tr> <tr><td>__ 0 F</td><td>CDPS (Variable gain enabled)</td></tr> <tr><td>__ 2 5</td><td>POT (Position range)</td></tr> <tr><td>__ 2 6</td><td>PUS (Temporarily stopped)</td></tr> <tr><td>__ 2 7</td><td>MEND (Traveling completion)</td></tr> <tr><td>__ 2 8</td><td>CPO (Rough match)</td></tr> <tr><td>__ 3 5</td><td>ZP2 (Home position return completion 2)</td></tr> </tbody> </table>	Setting value	Output device	__ 0 0	Always off	__ 0 2	RD (Ready)	__ 0 3	ALM (Malfunction)	__ 0 4	INP (In-position)	__ 0 5	MBR (Electromagnetic brake interlock)	__ 0 6	DB (Dynamic brake interlock)	__ 0 7	TLC (Limiting torque)	__ 0 8	WNG (Warning)	__ 0 9	BWNG (Battery warning)	__ 0 A	SA (Speed reached)	__ 0 C	ZSP (Zero speed detection)	__ 0 F	CDPS (Variable gain enabled)	__ 2 5	POT (Position range)	__ 2 6	PUS (Temporarily stopped)	__ 2 7	MEND (Traveling completion)	__ 2 8	CPO (Rough match)	__ 3 5	ZP2 (Home position return completion 2)
							Setting value		Output device																																			
							__ 0 0		Always off																																			
__ 0 2	RD (Ready)																																											
__ 0 3	ALM (Malfunction)																																											
__ 0 4	INP (In-position)																																											
__ 0 5	MBR (Electromagnetic brake interlock)																																											
__ 0 6	DB (Dynamic brake interlock)																																											
__ 0 7	TLC (Limiting torque)																																											
__ 0 8	WNG (Warning)																																											
__ 0 9	BWNG (Battery warning)																																											
__ 0 A	SA (Speed reached)																																											
__ 0 C	ZSP (Zero speed detection)																																											
__ 0 F	CDPS (Variable gain enabled)																																											
__ 2 5	POT (Position range)																																											
__ 2 6	PUS (Temporarily stopped)																																											
__ 2 7	MEND (Traveling completion)																																											
__ 2 8	CPO (Rough match)																																											
__ 3 5	ZP2 (Home position return completion 2)																																											
0h																																												
0h																																												
PD10	<p>Output signal device selection 2 (CN6-15) Any output device can be assigned to the CN6-15 pin. ALM is assigned as the initial value.</p> <p>The devices that can be assigned and the setting method are the same as those for [Pr. PD09].</p> <p>0 0 x x: Select the CN6-15 pin output device.</p>	0003h	PD08	<p>Output device selection 2 Any output device can be assigned to the CN3-9 pin. INP (In-position) is assigned as the initial value.</p> <p>__ x x: Device selection Refer to the table of [Pr. PD07] for setting values.</p> <p>_ x __: For manufacturer setting</p> <p>x ___: For manufacturer setting</p>	04h	CP PS SP																																						
							0h																																					
							0h																																					
							0h																																					
PD11	<p>Output signal device selection 3 (CN6-16) Any output device can be assigned to the CN6-16 pin. ZP is assigned as the initial value.</p> <p>The devices that can be assigned and the setting method are the same as those for [Pr. PD09].</p> <p>0 0 x x: Select the CN6-16 pin output device.</p>	0024h	PD09	<p>Output device selection 3 Any output device can be assigned to the CN3-15 pin. ALM (Malfunction) is assigned as the initial value.</p> <p>__ x x: Device selection Refer to the table of [Pr. PD07] for setting values.</p> <p>_ x __: For manufacturer setting</p> <p>x ___: For manufacturer setting</p>	03h	CP PS SP																																						
							0h																																					
							0h																																					
							0h																																					

Part 7: Review on Replacement of MR-J3-_T_ (CC-Link communication operation) with MR-J4-_GF_

MR-J3-_T_			MR-J4-_GF_			Control mode																																									
No.	Name and function	Initial value	No.	Name and function	Initial value																																										
PD12	External DI function selection 1 Set any signal to be captured from the CN6 connector. ☐: Indicates that this is for manufacturer setting. Configuration is not allowed.	0C00h	<table border="1" style="margin-top: 10px;"> <thead> <tr> <th rowspan="2">Device name</th> <th colspan="2">Initial value</th> </tr> <tr> <th>BIN</th> <th>HEX</th> </tr> </thead> <tbody> <tr> <td></td> <td>0</td> <td rowspan="4">0</td> </tr> <tr> <td>Servo-on (SON)</td> <td>0</td> </tr> <tr> <td>Reset (RES)</td> <td>0</td> </tr> <tr> <td></td> <td>0</td> </tr> <tr> <td></td> <td>0</td> <td rowspan="4">0</td> </tr> <tr> <td>Proportional control (PC)</td> <td>0</td> </tr> <tr> <td>Clear (CR)</td> <td>0</td> </tr> <tr> <td>Forward rotation start (ST1)</td> <td>0</td> </tr> <tr> <td></td> <td>0</td> <td rowspan="4">C</td> </tr> <tr> <td>Reverse rotation start (ST2)</td> <td>0</td> </tr> <tr> <td>Internal torque limit (TL1)</td> <td>0</td> </tr> <tr> <td>Forward rotation stroke end (LSP)</td> <td>1</td> </tr> <tr> <td></td> <td>1</td> <td rowspan="4">0</td> </tr> <tr> <td>Reverse rotation stroke end (LSN)</td> <td>1</td> </tr> <tr> <td></td> <td>0</td> </tr> <tr> <td>Gain switching (CDP)</td> <td>0</td> </tr> </tbody> </table> <p style="font-size: small; margin-top: 5px;">BIN 0: Use for CC-Link BIN 1: Use for a CN6 connector external input signal</p>	Device name	Initial value		BIN	HEX		0	0	Servo-on (SON)	0	Reset (RES)	0		0		0	0	Proportional control (PC)	0	Clear (CR)	0	Forward rotation start (ST1)	0		0	C	Reverse rotation start (ST2)	0	Internal torque limit (TL1)	0	Forward rotation stroke end (LSP)	1		1	0	Reverse rotation stroke end (LSN)	1		0	Gain switching (CDP)	0	PD41 Function selection D-4 ___x: 0h For manufacturer setting __x_: 0h For manufacturer setting _x__: 0h For manufacturer setting (no corresponding parameter) x___: 0h Sensor input method selection Select the input method for the proximity dog and stroke limits. 0: Input from servo amplifier (LSP/LSN/DOG) 1: Input from controller (FLS/RLS/DOG) When selecting "0", wire the limit switch installed in CCW direction to LSP, and wire the limit switch installed in CW direction to LSN. If the wiring is reversed, the servo motor will not stop at the limit switch. When selecting "1", set the limit switch installed in position address increasing direction to FLS, and the limit switch installed in decreasing direction to RLS. After that, input them from the controller. If the wiring is reversed, the servo motor will not stop at the limit switch. For details, refer to the controller user's manual.	0h	CP PS
					Device name	Initial value																																									
BIN	HEX																																														
	0	0																																													
Servo-on (SON)	0																																														
Reset (RES)	0																																														
	0																																														
	0	0																																													
Proportional control (PC)	0																																														
Clear (CR)	0																																														
Forward rotation start (ST1)	0																																														
	0	C																																													
Reverse rotation start (ST2)	0																																														
Internal torque limit (TL1)	0																																														
Forward rotation stroke end (LSP)	1																																														
	1	0																																													
Reverse rotation stroke end (LSN)	1																																														
	0																																														
Gain switching (CDP)	0																																														
PD14 External DI function selection 3 Set any signal to be captured from the CN6 connector. ☐: Indicates that this is for manufacturer setting. Configuration is not allowed.	0800h	<table border="1" style="margin-top: 10px;"> <thead> <tr> <th rowspan="2">Device name</th> <th colspan="2">Initial value</th> </tr> <tr> <th>BIN</th> <th>HEX</th> </tr> </thead> <tbody> <tr> <td></td> <td>0</td> <td rowspan="4">0</td> </tr> <tr> <td>Automatic/manual selection (MD0)</td> <td>0</td> </tr> <tr> <td></td> <td>0</td> </tr> <tr> <td></td> <td>0</td> </tr> <tr> <td></td> <td>0</td> <td rowspan="4">0</td> </tr> <tr> <td></td> <td>0</td> </tr> <tr> <td>Temporary stop/Restart (TSTP)</td> <td>0</td> </tr> <tr> <td></td> <td>0</td> </tr> <tr> <td></td> <td>0</td> <td rowspan="4">8</td> </tr> <tr> <td></td> <td>0</td> </tr> <tr> <td></td> <td>0</td> </tr> <tr> <td>Proximity dog (DOG)</td> <td>1</td> </tr> </tbody> </table> <p style="font-size: small; margin-top: 5px;">BIN 0: Used in CC-Link BIN 1: Used in CN6 external input signal</p>	Device name	Initial value		BIN	HEX		0	0	Automatic/manual selection (MD0)	0		0		0		0	0		0	Temporary stop/Restart (TSTP)	0		0		0	8		0		0	Proximity dog (DOG)	1	0h												
Device name	Initial value																																														
	BIN	HEX																																													
	0	0																																													
Automatic/manual selection (MD0)	0																																														
	0																																														
	0																																														
	0	0																																													
	0																																														
Temporary stop/Restart (TSTP)	0																																														
	0																																														
	0	8																																													
	0																																														
	0																																														
Proximity dog (DOG)	1																																														

Part 7: Review on Replacement of MR-J3-_T_ (CC-Link communication operation) with MR-J4-_GF_

MR-J3-_T_			MR-J4-_GF_			Control mode																			
No.	Name and function	Initial value	No.	Name and function	Initial value																				
PD16	Input polarity selection Select the proximity dog input polarity. 0 0 0 x: Proximity dog input polarity 0: Dog detection with off 1: Dog detection with on	0000h	PT29	Function selection T-3 Set the polarity of DOG.	0h	CP PS																			
				___ x (BIN): DOG (Proximity dog) polarity selection ▪ For the point table method 0: Dog detection with off 1: Dog detection with on ▪ For the indexer method 0: Dog detection with on 1: Dog detection with off																					
				___ x (BIN): For manufacturer setting																					
				_ x _ (BIN): For manufacturer setting																					
				x _ _ (BIN): For manufacturer setting																					
				_ _ x _ (BIN): For manufacturer setting _ _ x _ (BIN): For manufacturer setting _ x _ _ (BIN): For manufacturer setting x _ _ _ (BIN): For manufacturer setting																					
				_ x _ _ (BIN): For manufacturer setting _ x _ _ (BIN): For manufacturer setting x _ _ _ (BIN): For manufacturer setting																					
				x _ _ _ (BIN): For manufacturer setting x _ _ _ (BIN): For manufacturer setting x _ _ _ (BIN): For manufacturer setting x _ _ _ (BIN): For manufacturer setting																					
				<table border="1" style="display: inline-table; margin-left: 20px;"> <thead> <tr> <th rowspan="2">Setting</th> <th colspan="2">Initial value</th> </tr> <tr> <th>BIN</th> <th>HEX</th> </tr> </thead> <tbody> <tr> <td>DOG (Proximity dog) polarity selection</td> <td>0</td> <td>0</td> </tr> <tr> <td></td> <td>0</td> <td>0</td> </tr> <tr> <td></td> <td>0</td> <td>0</td> </tr> <tr> <td></td> <td>0</td> <td>0</td> </tr> </tbody> </table>			Setting	Initial value		BIN	HEX	DOG (Proximity dog) polarity selection	0	0		0	0		0	0		0	0		
				Setting				Initial value																	
							BIN	HEX																	
				DOG (Proximity dog) polarity selection			0	0																	
							0	0																	
							0	0																	
							0	0																	
PD19	Input filter setting Select the input filter. 0 0 0 x: Input filter If the external input signal causes chattering due to noise or other factors, the input filter can be used for suppression. 0: None 1: 0.888 [ms] 2: 1.777 [ms] 3: 2.660 [ms] 4: 3.555 [ms] 5: 4.444 [ms]	0002h	PD11	Input filter setting Input signal filter selection ___ x: If the external input signal causes chattering due to noise or other factors, the input filter can be used for suppression. 0: None 1: 0.888 [ms] 2: 1.777 [ms] 3: 2.666 [ms] 4: 3.555 [ms] 5: 4.444 [ms] 6: 5.333 [ms]	4h	CP PS SP																			
				RES (Reset) dedicated filter selection _ _ x _: 0: Disabled 1: Enabled (50 [ms])			0h	CP PS SP																	
				CR (Clear) dedicated filter selection _ x _ _: 0: Disabled 1: Enabled (50 [ms])			0h	CP PS																	
				x _ _ _: For manufacturer setting	0h																				

Part 7: Review on Replacement of MR-J3-_T_ (CC-Link communication operation) with MR-J4-_GF_

MR-J3-_T_			MR-J4-_GF_			Control mode
No.	Name and function	Initial value	No.	Name and function	Initial value	
PD20	Function selection D-1 Select the stop processing method when Forward rotation stroke end (LSP) or Reverse rotation stroke end (LSN) is turned off, or select the base circuit status when Reset (RY (n + 1) A or RY (n + 3) A) is turned on. 0 __ x: Stop method when Forward rotation stroke end (LSP) or Reverse rotation stroke end (LSN) is turned off 0: Quick stop (home position erased) 1: Slow stop (home position erased) 2: Slow stop (deceleration stop due to deceleration time constant) 3: Quick stop (stop due to remaining distance clear)	0010h	PD12	Function selection D-1 __ _ x: Stop method selection at stroke limit detection Select the stop method when RY (n + 1) 0 (upper stroke limit) or RY (n + 1) 1 (lower stroke limit) is off. 0: Quick stop (home position erased) 1: Slow stop (home position erased) 2: Slow stop (deceleration stop due to deceleration time constant) 3: Quick stop (stop due to remaining distance clear) If a value other than the value described in the setting value column is set, [AL. 37 Parameter error] occurs.	1h	CP
	0 _ x _: Base circuit status selection when Reset (RY (n + 1) A or RY (n + 3) A) is turned off 0: Base circuit shut-off 1: Base circuit not shut-off			0h		
	0 x __: Stop processing at software limit detection 0: Quick stop (home position erased) 1: Slow stop (home position erased) 2: Slow stop (deceleration stop due to deceleration time constant) 3: Quick stop (stop due to remaining distance clear) If the home position is erased due to the detection of the forward rotation stroke end, reverse rotation stroke end, or software limit while the parameters are set as follows, Home position return completion (ZP) turns on by turning off and on Servo-on (RYn0). In this case, it is not necessary to execute homing again. 1. For the absolute position detection system [Pr. PA03]: __ _ 1 (Select the absolute position detection system) [Pr. PA01]: __ _ 0 (Select the absolute value command method) 2. For the incremental system [Pr. PA03]: __ _ 0 (Select the incremental system) [Pr. PA01]: __ _ 0 (Select the absolute value command method) [Pr. PA04]: __ _ 1 (Follow-up enabled)			1h	CP	
	x __ _: Servo motor thermistor enabled/disabled selection 0: Enabled 1: Disabled This digit is enabled only when a servo motor with a built-in thermistor is used. When using a servo motor that does not have a built-in thermistor, this digit setting is disabled.			0h	CP PS SP	

Part 7: Review on Replacement of MR-J3-_T_ (CC-Link communication operation) with MR-J4-_GF_

MR-J3-_T_			MR-J4-_GF_						
No.	Name and function	Initial value	No.	Name and function	Initial value	Control mode			
PD20	<p>Function selection D-1</p> <p>Select the stop processing method when Forward rotation stroke end (LSP) or Reverse rotation stroke end (LSN) is turned off, or select the base circuit status when Reset (RY (n + 1) A or RY (n + 3) A) is turned on.</p> <p>0 __ x:</p> <p>Stop method when Forward rotation stroke end (LSP) or Reverse rotation stroke end (LSN) is turned off</p> <p>0: Quick stop (home position erased)</p> <p>1: Slow stop (home position erased)</p> <p>2: Slow stop (same setting as that of "1")</p> <p>3: Quick stop (same setting as that of "0")</p> <p>Even in this case, when LSP or LSN is detected, it is necessary to execute homing again before performing automatic operation. However, in the absolute position detection system ([Pr. PA03]: ___ 1), Home position return completion (ZP) can be turned on with servo-on. In this case, it is not necessary to execute homing again.</p>	0010h	PD12	<p>Function selection D-1</p> <p>___ x:</p> <p>Stop method selection at stroke limit detection</p> <p>Select the stop method when RY (n + 1) 0 (upper stroke limit) or RY (n + 1) 1 (lower stroke limit) is off.</p> <p>0: Quick stop (home position erased)</p> <p>1: Slow stop (home position erased)</p> <p>2: Slow stop (same setting as that of "1")</p> <p>3: Quick stop (same setting as that of "0")</p> <p>If a value other than the value described in the setting value column is set, [AL. 37 Parameter error] occurs.</p>	1h	PS			
							<p>__ x _:</p> <p>For manufacturer setting (no corresponding parameter)</p>	0h	
							<p>_ x _:</p> <p>For manufacturer setting (no corresponding parameter)</p>	1h	
	<p>00 x _:</p> <p>Base circuit status selection when Reset (RY (n + 1) A or RY (n + 3) A) is turned off</p> <p>0: Base circuit shut-off</p> <p>1: Base circuit not shut-off</p>		<p>x ___:</p> <p>Servo motor thermistor enabled/disabled selection</p> <p>0: Enabled</p> <p>1: Disabled</p> <p>This digit is enabled only when a servo motor with a built-in thermistor is used.</p> <p>When using a servo motor that does not have a built-in thermistor, this digit setting is disabled.</p>	0h	CP PS SP				
PD20	<p>Function selection D-1</p> <p>Select the stop processing method when Forward rotation stroke end (LSP) or Reverse rotation stroke end (LSN) is turned off, or select the base circuit status when Reset (RY (n + 1) A or RY (n + 3) A) is turned on.</p> <p>0 0 _ x:</p> <p>Stop method when Forward rotation stroke end (LSP) or Reverse rotation stroke end (LSN) is turned off</p> <p>0: Quick stop</p> <p>1: Slow stop</p>	0010h	PD12	<p>Function selection D-1</p> <p>___ x:</p> <p>Stop method selection at stroke limit detection</p> <p>Select the stop method when RY (n + 1) 0 (upper stroke limit) or RY (n + 1) 1 (lower stroke limit) is off.</p> <p>0: Quick stop (stop due to clearing speed command 0)</p> <p>1: Slow stop (deceleration stop due to deceleration time constant)</p> <p>If a value other than the value described in the setting value column is set, [AL. 37 Parameter error] occurs.</p>	1h	SP			
							<p>__ x _:</p> <p>For manufacturer setting (no corresponding parameter)</p>	0h	
							<p>_ x _:</p> <p>For manufacturer setting (no corresponding parameter)</p>	1h	
	<p>00 x _:</p> <p>Base circuit status selection when Reset (RY (n + 1) A or RY (n + 3) A) is turned off</p> <p>0: Base circuit shut-off</p> <p>1: Base circuit not shut-off</p>		<p>x ___:</p> <p>Servo motor thermistor enabled/disabled selection</p> <p>0: Enabled</p> <p>1: Disabled</p> <p>This digit is enabled only when a servo motor with a built-in thermistor is used.</p> <p>When using a servo motor that does not have a built-in thermistor, this digit setting is disabled.</p>	0h	CP PS SP				
PD22	<p>Function selection D-3</p> <p>Set Clear (RYnF).</p> <p>0 0 0 x:</p> <p>Clear (RYnF) selection</p> <p>0: Disabled</p> <p>1: Delete droop pulses by turning on the device.</p> <p>2: Always delete droop pulses during the device on.</p>	0000h	PD42	<p>Function selection D-5</p> <p>___ x:</p> <p>CR (Clear) selection</p> <p>0: Delete droop pulses by turning on the device.</p> <p>1: Always delete droop pulses during the device on.</p> <p>2: Disabled</p>	0h	CP PS			
							<p>__ x _:</p> <p>For manufacturer setting</p>	0h	
							<p>_ x _:</p> <p>For manufacturer setting</p>	0h	
			<p>x ___:</p> <p>For manufacturer setting</p>	0h					

Part 7: Review on Replacement of MR-J3-_T_ (CC-Link communication operation) with MR-J4-_GF_

MR-J3-_T_			MR-J4-_GF_																																																																																																																												
No.	Name and function	Initial value	No.	Name and function	Initial value	Control mode																																																																																																																									
PD24	Function selection D-5 Select the output status of Warning (RXnA).	0000h	PD14	Function selection D-3 ___X: For manufacturer setting	0h	CP PS SP																																																																																																																									
	0 0 x 0: Output device status at warning occurrence			___X__: Output device status at warning occurrence Select WNG (Warning) and ALM (Malfunction) output status at warning occurrence.																																																																																																																											
	<div style="border: 1px solid black; padding: 5px; display: inline-block;"> <table border="1" style="border-collapse: collapse; text-align: center;"> <tr> <td style="width: 20px;">0</td> <td style="width: 20px;">0</td> <td style="width: 20px;"> </td> <td style="width: 20px;">0</td> </tr> </table> </div> <p>Output device status at warning occurrence Select the output status of Warning (RXnA) and Malfunction (RX (n + 1) A or RX (n + 3) A) at warning occurrence.</p> <table border="1" style="border-collapse: collapse; width: 100%;"> <thead> <tr> <th style="width: 10%;">Setting value</th> <th style="width: 10%;">Device status (Note)</th> </tr> </thead> <tbody> <tr> <td style="text-align: center;">0</td> <td> <table border="0" style="width: 100%;"> <tr> <td style="width: 15%;">CC-Link RX</td> <td style="width: 15%;">RXnA</td> <td style="width: 10%;">1</td> <td style="width: 10%;"></td> <td style="width: 10%;"></td> <td style="width: 10%;"></td> <td style="width: 10%;"></td> <td style="width: 10%;"></td> </tr> <tr> <td></td> <td>RX (n + 1) A or RX (n + 3) A</td> <td>1</td> <td></td> <td></td> <td></td> <td></td> <td></td> </tr> <tr> <td></td> <td></td> <td>0</td> <td></td> <td></td> <td></td> <td></td> <td></td> </tr> <tr> <td>Output device</td> <td>WNG</td> <td>ON</td> <td></td> <td></td> <td></td> <td></td> <td></td> </tr> <tr> <td></td> <td></td> <td>OFF</td> <td></td> <td></td> <td></td> <td></td> <td></td> </tr> <tr> <td></td> <td>ALM</td> <td>ON</td> <td></td> <td></td> <td></td> <td></td> <td></td> </tr> <tr> <td></td> <td></td> <td>OFF</td> <td></td> <td></td> <td></td> <td></td> <td style="text-align: right;">Warning occurrence</td> </tr> </table> </td> </tr> <tr> <td style="text-align: center;">1</td> <td> <table border="0" style="width: 100%;"> <tr> <td style="width: 15%;">CC-Link RX</td> <td style="width: 15%;">RXnA</td> <td style="width: 10%;">1</td> <td style="width: 10%;"></td> <td style="width: 10%;"></td> <td style="width: 10%;"></td> <td style="width: 10%;"></td> <td style="width: 10%;"></td> </tr> <tr> <td></td> <td>RX (n + 1) A or RX (n + 3) A</td> <td>1</td> <td></td> <td></td> <td></td> <td></td> <td></td> </tr> <tr> <td></td> <td></td> <td>0</td> <td></td> <td></td> <td></td> <td></td> <td></td> </tr> <tr> <td>Output device</td> <td>WNG</td> <td>ON</td> <td></td> <td></td> <td></td> <td></td> <td></td> </tr> <tr> <td></td> <td></td> <td>OFF</td> <td></td> <td></td> <td></td> <td></td> <td></td> </tr> <tr> <td></td> <td>ALM</td> <td>ON</td> <td></td> <td></td> <td></td> <td></td> <td></td> </tr> <tr> <td></td> <td></td> <td>OFF</td> <td></td> <td></td> <td></td> <td></td> <td style="text-align: right;">Warning occurrence</td> </tr> </table> </td> </tr> </tbody> </table> <p>Note. 0: OFF 1: ON</p>	0	0		0	Setting value	Device status (Note)	0	<table border="0" style="width: 100%;"> <tr> <td style="width: 15%;">CC-Link RX</td> <td style="width: 15%;">RXnA</td> <td style="width: 10%;">1</td> <td style="width: 10%;"></td> <td style="width: 10%;"></td> <td style="width: 10%;"></td> <td style="width: 10%;"></td> <td style="width: 10%;"></td> </tr> <tr> <td></td> <td>RX (n + 1) A or RX (n + 3) A</td> <td>1</td> <td></td> <td></td> <td></td> <td></td> <td></td> </tr> <tr> <td></td> <td></td> <td>0</td> <td></td> <td></td> <td></td> <td></td> <td></td> </tr> <tr> <td>Output device</td> <td>WNG</td> <td>ON</td> <td></td> <td></td> <td></td> <td></td> <td></td> </tr> <tr> <td></td> <td></td> <td>OFF</td> <td></td> <td></td> <td></td> <td></td> <td></td> </tr> <tr> <td></td> <td>ALM</td> <td>ON</td> <td></td> <td></td> <td></td> <td></td> <td></td> </tr> <tr> <td></td> <td></td> <td>OFF</td> <td></td> <td></td> <td></td> <td></td> <td style="text-align: right;">Warning occurrence</td> </tr> </table>	CC-Link RX	RXnA	1							RX (n + 1) A or RX (n + 3) A	1								0						Output device	WNG	ON								OFF							ALM	ON								OFF					Warning occurrence	1	<table border="0" style="width: 100%;"> <tr> <td style="width: 15%;">CC-Link RX</td> <td style="width: 15%;">RXnA</td> <td style="width: 10%;">1</td> <td style="width: 10%;"></td> <td style="width: 10%;"></td> <td style="width: 10%;"></td> <td style="width: 10%;"></td> <td style="width: 10%;"></td> </tr> <tr> <td></td> <td>RX (n + 1) A or RX (n + 3) A</td> <td>1</td> <td></td> <td></td> <td></td> <td></td> <td></td> </tr> <tr> <td></td> <td></td> <td>0</td> <td></td> <td></td> <td></td> <td></td> <td></td> </tr> <tr> <td>Output device</td> <td>WNG</td> <td>ON</td> <td></td> <td></td> <td></td> <td></td> <td></td> </tr> <tr> <td></td> <td></td> <td>OFF</td> <td></td> <td></td> <td></td> <td></td> <td></td> </tr> <tr> <td></td> <td>ALM</td> <td>ON</td> <td></td> <td></td> <td></td> <td></td> <td></td> </tr> <tr> <td></td> <td></td> <td>OFF</td> <td></td> <td></td> <td></td> <td></td> <td style="text-align: right;">Warning occurrence</td> </tr> </table>	CC-Link RX	RXnA	1							RX (n + 1) A or RX (n + 3) A	1								0						Output device	WNG	ON								OFF							ALM	ON								OFF					Warning occurrence				
0	0		0																																																																																																																												
Setting value	Device status (Note)																																																																																																																														
0	<table border="0" style="width: 100%;"> <tr> <td style="width: 15%;">CC-Link RX</td> <td style="width: 15%;">RXnA</td> <td style="width: 10%;">1</td> <td style="width: 10%;"></td> <td style="width: 10%;"></td> <td style="width: 10%;"></td> <td style="width: 10%;"></td> <td style="width: 10%;"></td> </tr> <tr> <td></td> <td>RX (n + 1) A or RX (n + 3) A</td> <td>1</td> <td></td> <td></td> <td></td> <td></td> <td></td> </tr> <tr> <td></td> <td></td> <td>0</td> <td></td> <td></td> <td></td> <td></td> <td></td> </tr> <tr> <td>Output device</td> <td>WNG</td> <td>ON</td> <td></td> <td></td> <td></td> <td></td> <td></td> </tr> <tr> <td></td> <td></td> <td>OFF</td> <td></td> <td></td> <td></td> <td></td> <td></td> </tr> <tr> <td></td> <td>ALM</td> <td>ON</td> <td></td> <td></td> <td></td> <td></td> <td></td> </tr> <tr> <td></td> <td></td> <td>OFF</td> <td></td> <td></td> <td></td> <td></td> <td style="text-align: right;">Warning occurrence</td> </tr> </table>	CC-Link RX	RXnA	1							RX (n + 1) A or RX (n + 3) A	1								0						Output device	WNG	ON								OFF							ALM	ON								OFF					Warning occurrence																																																																						
CC-Link RX	RXnA	1																																																																																																																													
	RX (n + 1) A or RX (n + 3) A	1																																																																																																																													
		0																																																																																																																													
Output device	WNG	ON																																																																																																																													
		OFF																																																																																																																													
	ALM	ON																																																																																																																													
		OFF					Warning occurrence																																																																																																																								
1	<table border="0" style="width: 100%;"> <tr> <td style="width: 15%;">CC-Link RX</td> <td style="width: 15%;">RXnA</td> <td style="width: 10%;">1</td> <td style="width: 10%;"></td> <td style="width: 10%;"></td> <td style="width: 10%;"></td> <td style="width: 10%;"></td> <td style="width: 10%;"></td> </tr> <tr> <td></td> <td>RX (n + 1) A or RX (n + 3) A</td> <td>1</td> <td></td> <td></td> <td></td> <td></td> <td></td> </tr> <tr> <td></td> <td></td> <td>0</td> <td></td> <td></td> <td></td> <td></td> <td></td> </tr> <tr> <td>Output device</td> <td>WNG</td> <td>ON</td> <td></td> <td></td> <td></td> <td></td> <td></td> </tr> <tr> <td></td> <td></td> <td>OFF</td> <td></td> <td></td> <td></td> <td></td> <td></td> </tr> <tr> <td></td> <td>ALM</td> <td>ON</td> <td></td> <td></td> <td></td> <td></td> <td></td> </tr> <tr> <td></td> <td></td> <td>OFF</td> <td></td> <td></td> <td></td> <td></td> <td style="text-align: right;">Warning occurrence</td> </tr> </table>	CC-Link RX	RXnA	1							RX (n + 1) A or RX (n + 3) A	1								0						Output device	WNG	ON								OFF							ALM	ON								OFF					Warning occurrence																																																																						
CC-Link RX	RXnA	1																																																																																																																													
	RX (n + 1) A or RX (n + 3) A	1																																																																																																																													
		0																																																																																																																													
Output device	WNG	ON																																																																																																																													
		OFF																																																																																																																													
	ALM	ON																																																																																																																													
		OFF					Warning occurrence																																																																																																																								
PD25	<p>CC-Link communication error (A8D) detection time If "CC-Link communication error (A8D) detection delay" is selected for [Pr. PC50], this parameter is enabled. If [Pr. PC50] is "0000h", the set value becomes 10 ms. Convert the decimal to hexadecimal before entering. The maximum setting range is 1000 ms. If that range is exceeded, the value will be limited to the setting range. Example) When "03E8h" is set, the set value becomes 1000 ms. When "1388h" is set, the set value becomes 10000 ms when converted to decimal, but it will be regarded as 1000 ms, which is the upper limit of the setting range.</p> <div style="border: 1px solid black; padding: 5px;"> <p>CAUTION</p> <p>● If no CC-Link communication error (A8D) is detected, use the default value for the communication timeout detection time. When changing the setting value, do not set it longer than necessary. Otherwise, the servo motor will not be able to stop quickly at occurrence of CC-Link communication error (A8D).</p> </div>	0000h	PN02	<p>Communication error detection time Set the time until [AL. 8D.1 CC-Link IE communication error 1], [AL. 8D.6 CC-Link IE communication error 3] and [AL. 86.1 Network communication error 1] are detected. When "0" is set, the detection time changes as shown in the table below depending on the setting value of [Pr. PN03]. If [Pr. PD41] is set to "_ 1 ___" or "1 ___" and the setting value of this parameter is increased, the servo motor cannot be stopped at occurrence of a communication error. Be careful when changing the set value as there is a danger of collision.</p> <table border="1" style="border-collapse: collapse; width: 100%;"> <thead> <tr> <th style="width: 30%;">[Pr. PN03]</th> <th style="width: 70%;">Detection time</th> </tr> </thead> <tbody> <tr> <td style="text-align: center;">___ 1 (I/O mode)</td> <td style="text-align: center;">10.0 ms</td> </tr> </tbody> </table> <p>Setting range: 0 to 1000</p>	[Pr. PN03]	Detection time	___ 1 (I/O mode)	10.0 ms	0	CP PS SP																																																																																																																					
[Pr. PN03]	Detection time																																																																																																																														
___ 1 (I/O mode)	10.0 ms																																																																																																																														
PD26	<p>Torque limit delay time for indexer positioning operation Set the delay time in which Internal torque limit 2 ([Pr. PC35]) is enabled after In-position (RXn1) is turned on. Convert the delay time to hexadecimal before setting. The setting range is 0 to 1000 ms.</p>	0064h	PT39	<p>Torque limit delay time Set the delay time from when RXnC (travel completed) is output until [Pr. PC77 Internal torque limit 2] is enabled. Setting range: 0 to 1000</p>	100	PS																																																																																																																									

Part 7: Review on Replacement of MR-J3-_T_ (CC-Link communication operation) with MR-J4-_GF_

3.7 Replacement points and precautions

1. SUMMARY

This section describes the precautions for parameter setting when replacing MR-J3-_T_ with MR-J4-_GF_. For details on the parameters of MR-J3-_T_, refer to "MR-J3-_T_ Servo Amplifier Instruction Manual".

2. PRECAUTIONS

When migrating from MR-J3-_T_ to MR-J4-_GF_, using the parameter converter function of MR Configurator2 (available on version 1.120A or later) is recommended. However, this section provides supplementary explanation on parameters that can be easily overlooked when manually changing the parameter settings.

(1) [Pr. PA10 In-position range]

The initial value of [Pr. PA10] differs between MR-J3-_T_ and MR-J4-_GF_ (MR-J3-_T_: 100 μ m, MR-J4-_GF_: 1600 μ m). When INP (In-position) is assigned to [Pr. PD07] to [Pr. PD09], set [Pr. PA10] while referring to "MR-J4-_GF_ (-RJ) Servo Amplifier Instruction Manual (Motion Mode)" and "MR-J4-_GF_ (-RJ) Servo Amplifier Instruction Manual (I/O Mode)".

Number/abbreviation/ name	Setting digit	Function	Initial value [unit]
PA10 INP In-position range		<p>Set the in-position range in the command pulse unit.</p> <p>It can be changed to be in units of servo motor encoder pulse by setting [Pr. PC06]. In I/O mode, the in-position range is the range in which RXnC (travel completion) and RXn1 (in-position) are output.</p> <p>The unit is as follows depending on the positioning mode.</p> <ul style="list-style-type: none"> • For the point table method When [Pr. PC06] is set to "___0", the unit is fixed at [μm]. If [Pr. PC06] is set to "___1", the unit is fixed at [pulse]. • For the indexer method The unit is command unit [pulse]. (A unit that expresses one rotation on the machine side by the number of servo motor resolution pulses) For example, to set ± 1 degree as the in-position range for the rotation angle at the machine end, set $4194304 \times (1/360) = 11650$ pulses. <p>Setting range: 0 to 65535</p>	1600 [μ m]

Part 7: Review on Replacement of MR-J3-_T_ (CC-Link communication operation) with MR-J4-_GF_

(2) [Pr. PA11 Forward rotation torque limit]/[Pr. PA12 Reverse rotation torque limit]

The initial value of [Pr. PA11]/[Pr. PA12] differs between MR-J3-_T_ and MR-J4-_GF_ (MR-J3-_T_ : 100.0%, MR-J4-_GF_ : 1000.0%).

MR-J3-_T_ corresponds to the maximum torque when the setting value of [Pr. PA11]/[Pr. PA12] is 100.0%, while MR-J4-_GF_ corresponds to the rated torque when the setting value of [Pr. PA11]/[Pr. PA12] is 100.0%.

Number/abbreviation/ name	Setting digit	Function	Initial value [unit]
PA11 TLP Forward rotation torque limit		The torque generated by the servo motor can be limited. For MR-J4-_GF_, set the rated torque at 100.0 [%]. Set the servo parameter to limit the torque of the servo motor for CCW power running or CW regeneration. If this object is set to "0.0", the servo motor does not generate torque. The polarity of the torque limit can be changed with the setting values of [Pr. PA14 Rotation direction selection] and [Pr. PC29 POL reflection selection at torque mode]. Setting range: 0.0 to 1000.0	1000.0 [%]
PA12 TLN Reverse rotation torque limit		The torque generated by the servo motor can be limited. For MR-J4-_GF_, set the rated torque at 100.0 [%]. Set the servo parameter to limit the torque of the servo motor for CW power running or CCW regeneration. If this object is set to "0.0", the servo motor does not generate torque. The polarity of the torque limit can be changed with the setting values of [Pr. PA14 Rotation direction selection] and [Pr. PC29 POL reflection selection at torque mode]. Setting range: 0.0 to 1000.0	1000.0 [%]

(3) [Pr. PC02 Electromagnetic brake sequence output]

The parameter number and initial value differ between MR-J3-_T_ and MR-J4-_GF_ (MR-J3-_T_ : [Pr. PC16] initial value 100 ms, MR-J4-_GF_ : [Pr. PC02] initial value 0 ms). When MBR (Electromagnetic brake interlock) is assigned to [Pr. PD07] to [Pr. PD09], set [Pr. PC02] while referring to "MR-J4-_GF_ (-RJ) Servo Amplifier Instruction Manual (Motion Mode)" and "MR-J4-_GF_ (-RJ) Servo Amplifier Instruction Manual (I/O Mode)".

Number/abbreviation/ name	Setting digit	Function	Initial value [unit]
PC02 MBR Electromagnetic brake sequence output		Set the delay time used between the MBR (Electromagnetic brake interlock) shut-off and the base circuit shut-off. Setting range: 0 to 1000	0 [ms]

(4) [Pr. PC77 Internal torque limit 2]

The parameter number and initial value differ between MR-J3-_T_ and MR-J4-_GF_ (MR-J3-_T_ : [Pr. PC35] initial value 100.0%, MR-J4-_GF_ : [Pr. PC77] initial value 0.0%).

Number/abbreviation/ name	Setting digit	Function	Initial value [unit]
PC77 TL2 Internal torque limit 2		Set the servo parameter to limit the torque of the servo motor. Set the rated torque at 100.0%. If this object is set to "0.0", the servo motor does not generate torque. In positioning mode (indexer method), this parameter setting value is enabled while automatic operation, manual operation, and homing operation are stopped. During operation, the setting values of [Pr. PA11] and [Pr. PA12] are enabled. The internal torque limit selection function can also be used to enable/disable this parameter. Setting range: 0.0 to 1000.0	0.0 [%]

Part 7: Review on Replacement of MR-J3-_T_ (CC-Link communication operation) with MR-J4-_GF_

- (5) Input signal filter selection (_ _ _ x) in [Pr. PD11 Input filter setting]
 The initial value for input signal filter selection differs between MR-J3-_T_ and MR-J4-_GF_.

Number/abbreviation/ name	Setting digit	Function	Initial value [unit]																								
PD11 *DIF Input filter setting	Select the input signal filter.																										
	_ _ _ x	Input signal filter selection If the external input signal causes chattering due to noise or other factors, the input filter can be used for suppression. <table border="1" data-bbox="512 555 1275 875" style="margin: 10px auto;"> <thead> <tr> <th>Setting value</th> <th>MR-J3-_T_ [Pr. PD19]</th> <th>MR-J4-_GF_ [Pr. PD11]</th> </tr> </thead> <tbody> <tr> <td>0</td> <td>None</td> <td>None</td> </tr> <tr> <td>1</td> <td>0.888 [ms]</td> <td>0.888 [ms]</td> </tr> <tr> <td>2</td> <td>1.777 [ms] (initial value)</td> <td>1.777 [ms]</td> </tr> <tr> <td>3</td> <td>2.666 [ms]</td> <td>2.666 [ms]</td> </tr> <tr> <td>4</td> <td>3.555 [ms]</td> <td>3.555 [ms] (initial value)</td> </tr> <tr> <td>5</td> <td>4.444 [ms]</td> <td>4.444 [ms]</td> </tr> <tr> <td>6</td> <td></td> <td>5.333 [ms]</td> </tr> </tbody> </table>	Setting value	MR-J3-_T_ [Pr. PD19]	MR-J4-_GF_ [Pr. PD11]	0	None	None	1	0.888 [ms]	0.888 [ms]	2	1.777 [ms] (initial value)	1.777 [ms]	3	2.666 [ms]	2.666 [ms]	4	3.555 [ms]	3.555 [ms] (initial value)	5	4.444 [ms]	4.444 [ms]	6		5.333 [ms]	4h
	Setting value	MR-J3-_T_ [Pr. PD19]	MR-J4-_GF_ [Pr. PD11]																								
	0	None	None																								
1	0.888 [ms]	0.888 [ms]																									
2	1.777 [ms] (initial value)	1.777 [ms]																									
3	2.666 [ms]	2.666 [ms]																									
4	3.555 [ms]	3.555 [ms] (initial value)																									
5	4.444 [ms]	4.444 [ms]																									
6		5.333 [ms]																									
_ _ x _	RES (Reset) dedicated filter selection 0: Disabled 1: Enabled (50 [ms]) MR-J3-_T_ does not have this digit setting.	0h																									
_ x _ _	CR (Clear) dedicated filter selection 0: Disabled 1: Enabled (50 [ms]) MR-J3-_T_ does not have this digit setting.	0h																									
x _ _ _	For manufacturer setting	0h																									

Part 7: Review on Replacement of MR-J3-_T_ (CC-Link communication operation) with MR-J4-_GF_

- (6) Stop method selection at stroke limit detection (_ _ _ x) in [Pr. PD12 Function selection D-1]
 The initial value for stop method selection at stroke limit detection differs between MR-J3-_T_ and MR-J4-_GF_.

Number/abbreviation/ name	Setting digit	Function	Initial value [unit]																																							
PD12 *DOP1 Function selection D-1	_ _ _ x	<p>Stop method selection at stroke limit detection</p> <p>Select the stop method when RY (n + 1) 0 (upper stroke limit) or RY (n + 1) 1 (lower stroke limit) is off.</p> <p>For MR-J3-_T_, the upper stroke limit corresponds to the "forward rotation stroke end" and the lower stroke limit corresponds to the "reverse rotation stroke end".</p> <ul style="list-style-type: none"> Positioning mode (point table method) <table border="1" style="margin-left: 20px;"> <thead> <tr> <th>Setting value</th> <th>MR-J3-_T_ [Pr. PD20]</th> <th>MR-J4-_GF_ [Pr. PD12]</th> </tr> </thead> <tbody> <tr> <td>0</td> <td>Quick stop (home position erased) (initial value)</td> <td>Quick stop (home position erased)</td> </tr> <tr> <td>1</td> <td>Slow stop (home position erased)</td> <td>Slow stop (home position erased) (initial value)</td> </tr> <tr> <td>2</td> <td>Slow stop (deceleration stop due to deceleration time constant)</td> <td>Slow stop (deceleration stop due to deceleration time constant)</td> </tr> <tr> <td>3</td> <td>Quick stop (stop due to remaining distance clear)</td> <td>Quick stop (stop due to remaining distance clear)</td> </tr> </tbody> </table> Positioning mode (indexer method) <table border="1" style="margin-left: 20px;"> <thead> <tr> <th>Setting value</th> <th>MR-J3-_T_ [Pr. PD20]</th> <th>MR-J4-_GF_ [Pr. PD12]</th> </tr> </thead> <tbody> <tr> <td>0</td> <td>Quick stop (home position erased) (initial value)</td> <td>Quick stop (home position erased)</td> </tr> <tr> <td>1</td> <td>Slow stop (home position erased)</td> <td>Slow stop (home position erased) (initial value)</td> </tr> <tr> <td>2</td> <td>Slow stop (same setting as that of "1")</td> <td>Slow stop (same setting as that of "1")</td> </tr> <tr> <td>3</td> <td>Quick stop (same setting as that of "0")</td> <td>Quick stop (same setting as that of "0")</td> </tr> </tbody> </table> Speed control mode (point table method) <table border="1" style="margin-left: 20px;"> <thead> <tr> <th>Setting value</th> <th>MR-J3-_T_ [Pr. PD20]</th> <th>MR-J4-_GF_ [Pr. PD12]</th> </tr> </thead> <tbody> <tr> <td>0</td> <td>Quick stop (initial value)</td> <td>Quick stop (stop due to clearing speed command 0)</td> </tr> <tr> <td>1</td> <td>Slow stop</td> <td>Slow stop (deceleration stop due to deceleration time constant) (initial value)</td> </tr> </tbody> </table> 	Setting value	MR-J3-_T_ [Pr. PD20]	MR-J4-_GF_ [Pr. PD12]	0	Quick stop (home position erased) (initial value)	Quick stop (home position erased)	1	Slow stop (home position erased)	Slow stop (home position erased) (initial value)	2	Slow stop (deceleration stop due to deceleration time constant)	Slow stop (deceleration stop due to deceleration time constant)	3	Quick stop (stop due to remaining distance clear)	Quick stop (stop due to remaining distance clear)	Setting value	MR-J3-_T_ [Pr. PD20]	MR-J4-_GF_ [Pr. PD12]	0	Quick stop (home position erased) (initial value)	Quick stop (home position erased)	1	Slow stop (home position erased)	Slow stop (home position erased) (initial value)	2	Slow stop (same setting as that of "1")	Slow stop (same setting as that of "1")	3	Quick stop (same setting as that of "0")	Quick stop (same setting as that of "0")	Setting value	MR-J3-_T_ [Pr. PD20]	MR-J4-_GF_ [Pr. PD12]	0	Quick stop (initial value)	Quick stop (stop due to clearing speed command 0)	1	Slow stop	Slow stop (deceleration stop due to deceleration time constant) (initial value)	1h
Setting value	MR-J3-_T_ [Pr. PD20]	MR-J4-_GF_ [Pr. PD12]																																								
0	Quick stop (home position erased) (initial value)	Quick stop (home position erased)																																								
1	Slow stop (home position erased)	Slow stop (home position erased) (initial value)																																								
2	Slow stop (deceleration stop due to deceleration time constant)	Slow stop (deceleration stop due to deceleration time constant)																																								
3	Quick stop (stop due to remaining distance clear)	Quick stop (stop due to remaining distance clear)																																								
Setting value	MR-J3-_T_ [Pr. PD20]	MR-J4-_GF_ [Pr. PD12]																																								
0	Quick stop (home position erased) (initial value)	Quick stop (home position erased)																																								
1	Slow stop (home position erased)	Slow stop (home position erased) (initial value)																																								
2	Slow stop (same setting as that of "1")	Slow stop (same setting as that of "1")																																								
3	Quick stop (same setting as that of "0")	Quick stop (same setting as that of "0")																																								
Setting value	MR-J3-_T_ [Pr. PD20]	MR-J4-_GF_ [Pr. PD12]																																								
0	Quick stop (initial value)	Quick stop (stop due to clearing speed command 0)																																								
1	Slow stop	Slow stop (deceleration stop due to deceleration time constant) (initial value)																																								

Part 7: Review on Replacement of MR-J3-_T_ (CC-Link communication operation) with MR-J4-_GF_

(7) Stop method selection at software limit detection (_ x _ _) in [Pr. PD12 Function selection D-1]
 The initial value for stop method selection at software limit detection differs between MR-J3-_T_ and MR-J4-_GF_.

Number/abbreviation/ name	Setting digit	Function	Initial value [unit]															
PD12 *DOP1 Function selection D-1	_ x _ _	Stop method selection at software limit detection Select the stop method at the software limit detection. • Positioning mode (point table method) <table border="1" data-bbox="518 562 1265 857"> <thead> <tr> <th data-bbox="518 562 678 620">Setting value</th> <th data-bbox="678 562 965 620">MR-J3-_T_ [Pr. PD20]</th> <th data-bbox="965 562 1265 620">MR-J4-_GF_ [Pr. PD12]</th> </tr> </thead> <tbody> <tr> <td data-bbox="518 620 678 678">0</td> <td data-bbox="678 620 965 678">Quick stop (home position erased) (initial value)</td> <td data-bbox="965 620 1265 678">Quick stop (home position erased)</td> </tr> <tr> <td data-bbox="518 678 678 736">1</td> <td data-bbox="678 678 965 736">Slow stop (home position erased)</td> <td data-bbox="965 678 1265 736">Slow stop (home position erased) (initial value)</td> </tr> <tr> <td data-bbox="518 736 678 795">2</td> <td data-bbox="678 736 965 795">Slow stop (deceleration stop due to deceleration time constant)</td> <td data-bbox="965 736 1265 795">Slow stop (deceleration stop due to deceleration time constant)</td> </tr> <tr> <td data-bbox="518 795 678 857">3</td> <td data-bbox="678 795 965 857">Quick stop (stop due to remaining distance clear)</td> <td data-bbox="965 795 1265 857">Quick stop (stop due to remaining distance clear)</td> </tr> </tbody> </table>	Setting value	MR-J3-_T_ [Pr. PD20]	MR-J4-_GF_ [Pr. PD12]	0	Quick stop (home position erased) (initial value)	Quick stop (home position erased)	1	Slow stop (home position erased)	Slow stop (home position erased) (initial value)	2	Slow stop (deceleration stop due to deceleration time constant)	Slow stop (deceleration stop due to deceleration time constant)	3	Quick stop (stop due to remaining distance clear)	Quick stop (stop due to remaining distance clear)	1h
Setting value	MR-J3-_T_ [Pr. PD20]	MR-J4-_GF_ [Pr. PD12]																
0	Quick stop (home position erased) (initial value)	Quick stop (home position erased)																
1	Slow stop (home position erased)	Slow stop (home position erased) (initial value)																
2	Slow stop (deceleration stop due to deceleration time constant)	Slow stop (deceleration stop due to deceleration time constant)																
3	Quick stop (stop due to remaining distance clear)	Quick stop (stop due to remaining distance clear)																

Part 7: Review on Replacement of MR-J3-_T_ (CC-Link communication operation) with MR-J4-_GF_

(8) CR (Clear) selection (___x) in [Pr. PD42 Function selection D-5]

The setting value for CR (Clear) selection differs between MR-J3-_T_ and MR-J4-_GF_.

Number/abbreviation/ name	Setting digit	Function	Initial value [unit]												
PD42 *DOP5 Function selection D-5	___x	CR (Clear) selection <table border="1" style="margin: 10px auto; width: 80%;"> <thead> <tr> <th>Setting value</th> <th>MR-J3-_T_ [Pr. PD22]</th> <th>MR-J4-_GF_ [Pr. PD42]</th> </tr> </thead> <tbody> <tr> <td>0</td> <td>Disabled</td> <td>Delete droop pulses by turning on the device.</td> </tr> <tr> <td>1</td> <td>Delete droop pulses by turning on the device.</td> <td>Always delete droop pulses during the device on.</td> </tr> <tr> <td>2</td> <td>Always delete droop pulses during the device on.</td> <td>Disabled</td> </tr> </tbody> </table>	Setting value	MR-J3-_T_ [Pr. PD22]	MR-J4-_GF_ [Pr. PD42]	0	Disabled	Delete droop pulses by turning on the device.	1	Delete droop pulses by turning on the device.	Always delete droop pulses during the device on.	2	Always delete droop pulses during the device on.	Disabled	0h
Setting value	MR-J3-_T_ [Pr. PD22]	MR-J4-_GF_ [Pr. PD42]													
0	Disabled	Delete droop pulses by turning on the device.													
1	Delete droop pulses by turning on the device.	Always delete droop pulses during the device on.													
2	Always delete droop pulses during the device on.	Disabled													

(9) [Pr. PT05 Home position return speed]

The parameter number and initial value differ between MR-J3-_T_ and MR-J4-_GF_ (MR-J3-_T_: [Pr. PC04] initial value 500 r/min, MR-J4-_GF_: [Pr. PT05] initial value 100.00 r/min).

Number/abbreviation/ name	Setting digit	Function	Initial value [unit]
PT05 ZRF Homing speed	/	Set the servo motor speed for homing. Setting range: 0.00 to instantaneous permissible speed	100.00 [r/min]

(10) [Pr. PT28 Number of stations per rotation]

The parameter number and initial value differ between MR-J3-_T_ and MR-J4-_GF_ (MR-J3-_T_: [Pr. PC46] initial value 0000h, MR-J4-_GF_: [Pr. PT28] initial value eight stations).

Number/abbreviation/ name	Setting digit	Function	Initial value [unit]
PT28 *STN Number of stations per rotation	/	Set the number of stations (number of indexer stations) per rotation of the machine. If the setting value is "0" or "1", the number of stations will be 2. Setting range: 0 to 255	8 [divisions]

Part 8
Common Reference Material

Part 8: Common Reference Material

Part 8: Common Reference Material

1. SPECIFICATION DIFFERENCES

1.1 Detailed Specification/Function Differences

POINT
● Functions with difference are shown with shading.

(1) Comparison of MR-J3 series and MR-J4 series (General-purpose interface, SSCNET interface, DIO/Serial communication, CC-Link ⇒ CC-Link IE Field Network interface)

Item	MR-J3 series	MR-J4 series
1 Capacity range	General-purpose interface SSCNET III interface (50 Mbps) (100 V class) 0.1 kW to 0.4 kW (200 V class) 0.1 kW to 37 kW (400 V class) 0.6 kW to 55 kW DIO/Serial communication CC-Link interface (100 V class) 0.1 kW to 0.4 kW (200 V class) 0.1 kW to 22 kW (400 V class) 0.6 kW to 22 kW	General-purpose interface SSCNET III/H interface (100 V class) 0.1 kW to 0.4 kW (200 V class) 0.1 kW to 37 kW (400 V class) 0.6 kW to 55 kW CC-Link IE Field Network interface (100 V class) 0.1 kW to 0.4 kW (200 V class) 0.1 kW to 22 kW (400 V class) 0.6 kW to 22 kW
2 Regenerative resistor	Built-in (0.2 kW to 7 kW) External (11 kW to 55 kW)	Built-in (0.2 kW to 7 kW) External (11 kW to 55 kW)
3 Dynamic brake	Built-in (0.1 kW to 7 kW) External (11 kW to 55 kW)	Built-in (0.1 kW to 7 kW) External (11 kW to 55 kW) Coasting distance is different. (Note1)
4 Control circuit power	(100 V class) 1-phase 100V AC to 120V AC (200 V class) 1-phase 200V AC to 230V AC (400 V class) 1-phase 380V AC to 480V AC	(100 V class) 1-phase 100V AC to 120V AC (200 V class) 1-phase 200V AC to 240V AC (400 V class) 1-phase 380V AC to 480V AC
5 Main circuit power	(100 V class) 1-phase 100V AC to 120V AC (200 V class) 1-phase 230V AC 3-phase 200V AC to 230V AC (0.1 kW to 750 W) 3-phase 200V AC to 230V AC (0.1 kW to 37 kW) (400 V class) 3-phase 380V AC to 480V AC	(100 V class) 1-phase 100V AC to 120V AC (200 V class) 1-phase 200V AC to 240V AC (0.1 kW to 2 kW) 3-phase 200V AC to 240V AC (0.1 kW to 37 kW) (400 V class) 3-phase 380V AC to 480V AC
6 24 V DC power	External supply required	External supply required
7 Auto tuning	Real-time auto tuning: 32 steps Advanced gain search	Real-time auto tuning: 40 steps One-touch tuning
8 Control mode	General-purpose interface • Position control mode (pulse command) • Speed control mode (analog command) • Torque control mode (analog command) SSCNET III interface (50 Mbps) • Position control mode • Speed control mode DIO/Serial communication • Positioning mode (point table method) CC-Link interface • Positioning mode (point table method) • Positioning mode (indexer method) • Speed control mode (point table method)	General-purpose interface • Position control mode (pulse command) • Speed control mode (analog command) • Torque control mode (analog command) SSCNET III/H interface (150 Mbps) • Position control mode • Speed control mode Torque control mode DIO/Serial communication • Positioning mode (point table method) CC-Link IE Field Network interface • Positioning mode (point table method) • Positioning mode (indexer method) • Speed control mode (point table method) < J3 compatibility mode > SSCNET III/H interface (50 Mbps) • Position control mode • Speed control mode

Part 8: Common Reference Material

Item		MR-J3 series	MR-J4 series
9	Maximum input pulses (General-purpose interface)	Differential pulse: 1 Mpulse/s Command pulse: Sink	Differential pulse: 4 Mpulses/s Command pulse: Sink
10	The number of DIO points (excluding EM1)	General-purpose interface DI: 9 points, DO: 6 points SSCNET III interface DI: 3 points, DO: 3 points DIO/Serial communication < Not using extension I/O unit > DI: 3 points, DO: 3 points < Using extension I/O unit > DI: 23 points, DO: 19 points CC-Link interface DI: 3 points, DO: 3 points	General-purpose interface DI: 9 points, DO: 6 points SSCNET III/H interface DI: 3 points, DO: 3 points DIO/Serial communication < Not using extension I/O unit > DI: 13 points, DO: 6 points < Using extension I/O unit > DI: 33 points, DO: 22 points CC-Link IE Field Network interface DI: 3 points, DO: 3 points
11	Encoder pulse output	ABZ-phase (differential line driver) General-purpose interface Z-phase (open collector)	ABZ-phase (differential line driver) General-purpose interface Z-phase (open collector)
12	DIO interface	input/output: sink/source	input/output: sink/source
13	Analog input/output	General-purpose interface (Input) 2ch 10-bit torque, 14-bit speed or equivalent (Output) 10-bit or equivalent × 2ch SSCNET III interface (Output) 10-bit or equivalent × 2ch DIO/Serial communication < Not using extension I/O unit > (Input) 0 points (Output) 0 points < Using extension I/O unit > (Input) 2 points (Output) 2 points CC-Link interface (Input) 0 points (Output) 0 points	General-purpose interface (Input) 2ch 10-bit torque, 14-bit speed or equivalent (Output) 10-bit or equivalent × 2ch SSCNET III/H interface (Output) 10-bit or equivalent × 2ch DIO/Serial communication < Not using extension I/O unit > (Input) 2 points (Output) 2 points < Using extension I/O unit > (Input) 2 points (Note 2) (Output) 4 points CC-Link IE Field Network interface (Input) 0 points (Output) 2 points
14	Number of internal speed commands (General- purpose interface)	7 points	7 points
15	Parameter setting method	Setup software (SETUP221E) MR Configurator2 Push button (General-purpose interface)	MR Configurator2 Push button (General-purpose interface)
16	Setup software communication function	USB	USB
17	Servo motor (Encoder resolution)	HF-_P series (18-bit ABS) HA-_P series (18-bit ABS)	HG series (22-bit ABS)
18	Motor maximum torque	HF-KP 350% HF-MP 300% HF-SP 300% HF-JP 300% HA-LP 250%	HG-KR 350% HG-MR 300% HG-SR 300% HG-JR 300% HG-JR 300%
19	LED display	General-purpose interface • 7-segment 5-digit SSCNET III interface • 7-segment 3-digit DIO, Serial communication • 7-segment 3-digit	General-purpose interface • 7-segment 5-digit SSCNET III/H interface • 7-segment 3-digit DIO, Serial communication • 7-segment 5-digit
20	Advanced vibration suppression control	Provided	Provided (Advanced vibration suppression control II)
21	Adaptive filter II	Provided	Provided
22	Notch filter	Provided (2 pcs)	Provided (5 pcs)
23	Tough drive	Unprovided	Provided
24	Drive recorder	Unprovided	Provided
25	Forced stop	EM1 (DB stop)	EM1 (DB stop)/EM2 (deceleration to a stop)

- Note 1. For the coasting distance, refer to section "1.2.3 Dynamic brake: coasting distance".
2. The 2 analog inputs of MR-J4-_A_/_RJ and those of MR-D01 are mutually exclusive.

Part 8: Common Reference Material

1.2 Servo amplifier

1.2.1 Main circuit terminal block

Series	Main circuit terminal block	Series	Main circuit terminal block
MR-J3-10_ to MR-J3-60_		MR-J4-10_(-RJ) to MR-J4-60_(-RJ)	
MR-J3-70_ MR-J3-100_		MR-J4-70_(-RJ) MR-J4-100_(-RJ)	
MR-J3-200_N, /-200_(-RT)		MR-J4-200_(-RJ)	
MR-J3-350_		MR-J4-350_(-RJ)	



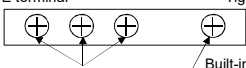
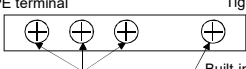



Part 8: Common Reference Material

Series	Main circuit terminal block	Series	Main circuit terminal block																				
MR-J3-500_	<p>TE1 L1 L2 L3 P C U V W</p> <p>TE2 L11 L21</p> <p>TE3 N P1 P2</p> <p>PE terminal  Built-in regenerative resistor lead terminal fixing screw</p> <p>TE1 Screw size: M4 Tightening torque: 1.2 [N·m] (10.6 [lb·in]) TE2 Screw size: M3.5 (Note) Tightening torque: 0.8 [N·m] (7.08 [lb·in]) TE3 Screw size: M4 Tightening torque: 1.2 [N·m] (10.6 [lb·in]) PE Screw size: M4 Tightening torque: 1.2 [N·m] (10.6 [lb·in])</p>	MR-J4-500_(-RJ)	<p>TE2 L11 L21 TE2 Screw size: M3.5 Tightening torque: 0.8 [N·m]</p> <p>TE1 L1 L2 L3 N- TE1 Screw size: M4 Tightening torque: 1.2 [N·m]</p> <p>TE3 P3 P4 P+ C TE3 Screw size: M4 Tightening torque: 1.2 [N·m]</p> <p>TE4 D U V W PE PE Screw size: M4 Tightening torque: 1.2 [N·m]</p>																				
MR-J3-700_	<p>TE1 L1 L2 L3 P C U V W</p> <p>TE2 L11 L21</p> <p>TE3 N P1 P2</p> <p>PE terminal  Built-in regenerative resistor lead terminal fixing screw</p> <p>TE1 Screw size: M4 Tightening torque: 1.2 [N·m] (10.6 [lb·in]) TE2 Screw size: M3.5 (Note) Tightening torque: 0.8 [N·m] (7.08 [lb·in]) TE3 Screw size: M4 Tightening torque: 1.2 [N·m] (10.6 [lb·in]) PE Screw size: M4 Tightening torque: 1.2 [N·m] (10.6 [lb·in])</p>	MR-J4-700_(-RJ)	<p>TE3 N-P3P4</p> <p>TE1 L1L2L3P+C U V W TE2 L11L21</p> <p>PE PE TE3 Screw size: M4 Tightening torque: 1.2 [N·m]</p> <p>TE1 Screw size: M4 Tightening torque: 1.2 [N·m]</p> <p>TE2 Screw size: M3.5 Tightening torque: 0.8 [N·m]</p> <p>PE Screw size: M4 Tightening torque: 1.2 [N·m]</p>																				
MR-J3-11K_(-LR) MR-J3-15K_(-LR)	<p>TE L1 L2 L3 L11 L21 U V W P1 P C N PE PE PE</p> <table border="1"> <thead> <tr> <th></th> <th></th> <th>L1/L2/L3/U/V/W/P1/P/C/N/PE</th> <th>L11/L21</th> </tr> </thead> <tbody> <tr> <td>MR-J3-11K_(4)</td> <td>Screw size</td> <td>M6</td> <td>M4</td> </tr> <tr> <td>MR-J3-15K_(4)</td> <td>Tightening torque [(lb.in)] [N·m]</td> <td>3.0</td> <td>1.2</td> </tr> <tr> <td>MR-J3-22K_(4)</td> <td>Screw size</td> <td>M8</td> <td>M4</td> </tr> <tr> <td>MR-J3-22K_(4)</td> <td>Tightening torque [(lb.in)] [N·m]</td> <td>6.0</td> <td>1.2</td> </tr> </tbody> </table>			L1/L2/L3/U/V/W/P1/P/C/N/PE	L11/L21	MR-J3-11K_(4)	Screw size	M6	M4	MR-J3-15K_(4)	Tightening torque [(lb.in)] [N·m]	3.0	1.2	MR-J3-22K_(4)	Screw size	M8	M4	MR-J3-22K_(4)	Tightening torque [(lb.in)] [N·m]	6.0	1.2	MR-J4-11K_(-RJ) MR-J4-15K_(-RJ)	<p>TE1-1 L1L2L3U V W</p> <p>TE1-2 P3P4P+C N- TE2 L11L21</p> <p>PE PE TE1-1 Screw size: M6 Tightening torque: 3.0 [N·m]</p> <p>TE1-2 Screw size: M6 Tightening torque: 3.0 [N·m]</p> <p>TE2 Screw size: M4 Tightening torque: 1.2 [N·m]</p> <p>PE Screw size: M6 Tightening torque: 3.0 [N·m]</p>
		L1/L2/L3/U/V/W/P1/P/C/N/PE	L11/L21																				
MR-J3-11K_(4)	Screw size	M6	M4																				
MR-J3-15K_(4)	Tightening torque [(lb.in)] [N·m]	3.0	1.2																				
MR-J3-22K_(4)	Screw size	M8	M4																				
MR-J3-22K_(4)	Tightening torque [(lb.in)] [N·m]	6.0	1.2																				
MR-J3-22K_	<p>TE L1 L2 L3 L11 L21 U V W P1 P C N PE PE PE</p> <table border="1"> <thead> <tr> <th></th> <th></th> <th>L1/L2/L3/U/V/W/P1/P/C/N/PE</th> <th>L11/L21</th> </tr> </thead> <tbody> <tr> <td>MR-J3-11K_(4)</td> <td>Screw size</td> <td>M6</td> <td>M4</td> </tr> <tr> <td>MR-J3-15K_(4)</td> <td>Tightening torque [(lb.in)] [N·m]</td> <td>3.0</td> <td>1.2</td> </tr> <tr> <td>MR-J3-22K_(4)</td> <td>Screw size</td> <td>M8</td> <td>M4</td> </tr> <tr> <td>MR-J3-22K_(4)</td> <td>Tightening torque [(lb.in)] [N·m]</td> <td>6.0</td> <td>1.2</td> </tr> </tbody> </table>			L1/L2/L3/U/V/W/P1/P/C/N/PE	L11/L21	MR-J3-11K_(4)	Screw size	M6	M4	MR-J3-15K_(4)	Tightening torque [(lb.in)] [N·m]	3.0	1.2	MR-J3-22K_(4)	Screw size	M8	M4	MR-J3-22K_(4)	Tightening torque [(lb.in)] [N·m]	6.0	1.2	MR-J4-22K_(-RJ)	<p>TE1-1 L1L2L3U V W</p> <p>TE1-2 P3P4P+C N-</p> <p>PE PE TE2 L11L21</p> <p>TE1-1 Screw size: M8 Tightening torque: 6.0 [N·m]</p> <p>TE1-2 Screw size: M8 Tightening torque: 6.0 [N·m]</p> <p>TE2 Screw size: M4 Tightening torque: 1.2 [N·m]</p> <p>PE Screw size: M8 Tightening torque: 6.0 [N·m]</p>
		L1/L2/L3/U/V/W/P1/P/C/N/PE	L11/L21																				
MR-J3-11K_(4)	Screw size	M6	M4																				
MR-J3-15K_(4)	Tightening torque [(lb.in)] [N·m]	3.0	1.2																				
MR-J3-22K_(4)	Screw size	M8	M4																				
MR-J3-22K_(4)	Tightening torque [(lb.in)] [N·m]	6.0	1.2																				

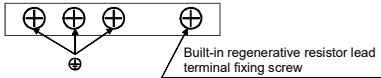
Part 8: Common Reference Material

Series	Main circuit terminal block	Series	Main circuit terminal block
MR-J3-DU30K_ MR-J3-DU37K_ MR-J3-DU45K_4 MR-J3-DU55K_4	<p>TE2-1 L+ L- TE3 L11 L21 TE1 U V W PE ⊕ ⊕</p> <p>TE2-1 Screw size: M6 Tightening torque: 3.0 [N•m] (26.6 [lb•in]) TE3 Screw size: M4 Tightening torque: 1.2 [N•m] (10.6 [lb•in]) TE1 Screw size: M10 Tightening torque: 10.0 [N•m] (88.5 [lb•in]) PE Screw size: M10 Tightening torque: 10.0 [N•m] (88.5 [lb•in])</p>	MR-J4-DU30K_ MR-J4-DU37K_ MR-J4-DU45K_4 MR-J4-DU55K_4	<p>TE2-1 L+ L- TE2-2 L+ L- TE3 L11 L21 PE ⊕ ⊕ U V W TE1 U V W</p> <p>TE1 Screw size: M10 Tightening torque: 12.0 [N•m] TE2-1 Screw size: M6 Tightening torque: 3.0 [N•m] TE2-2 Screw size: M6 Tightening torque: 3.0 [N•m] TE3 Screw size: M4 Tightening torque: 1.2 [N•m] PE Screw size: M10 Tightening torque: 12.0 [N•m]</p>
MR-J3-60_4 to MR-J3-200_4	<p>L1 L2 L3 N- P1 P2 P+ C D L11 L21 U V W</p> <p>CNP1 CNP2 CNP3</p> <p>PE terminal ⊕</p> <p>Screw size: M4 Tightening torque: 1.2 [N•m] (10.6 [lb•in])</p>	MR-J4-60_4(-RJ) to MR-J4-200_4(-RJ)	<p>N- L1 L2 L3 P3 P4 P+ C D L11 L21 U V W PE ⊕ ⊕</p> <p>Screw size: M4 Tightening torque: 1.2 [N•m]</p>
MR-J3-350_4	<p>TE1 L1 L2 L3 P C U V W TE2 L11 L21 TE3 N P1 P2 PE terminal ⊕ ⊕ ⊕ ⊕ Built-in regenerative resistor lead terminal fixing screw</p> <p>TE1 Screw size: M4 Tightening torque: 1.2 [N•m] (10.6 [lb•in]) TE2 Screw size: M3.5 (Note) Tightening torque: 0.8 [N•m] (7.08 [lb•in]) TE3 Screw size: M4 Tightening torque: 1.2 [N•m] (10.6 [lb•in]) PE Screw size: M4 Tightening torque: 1.2 [N•m] (10.6 [lb•in])</p>	MR-J4-350_4(-RJ)	<p>N- L1 L2 L3 P3 P4 P+ C D L11 L21 U V W PE ⊕ ⊕</p> <p>Screw size: M4 Tightening torque: 1.2 [N•m]</p>
MR-J3-500_4	<p>TE1 L1 L2 L3 P C U V W TE2 L11 L21 TE3 N P1 P2 PE terminal ⊕ ⊕ ⊕ ⊕ Built-in regenerative resistor lead terminal fixing screw</p> <p>TE1 Screw size: M4 Tightening torque: 1.2 [N•m] (10.6 [lb•in]) TE2 Screw size: M3.5 (Note) Tightening torque: 0.8 [N•m] (7.08 [lb•in]) TE3 Screw size: M4 Tightening torque: 1.2 [N•m] (10.6 [lb•in]) PE Screw size: M4 Tightening torque: 1.2 [N•m] (10.6 [lb•in])</p>	MR-J4-500_4(-RJ)	<p>TE2 L11 L21 TE3 N-P3 P4 TE1 L1 L2 L3 P+ C U V W PE ⊕ ⊕ TE2 Screw size: M3.5 Tightening torque: 0.8 [N•m] TE3 Screw size: M4 Tightening torque: 1.2 [N•m] TE1 Screw size: M4 Tightening torque: 1.2 [N•m] PE Screw size: M4 Tightening torque: 1.2 [N•m]</p>

Part 8: Common Reference Material

Series	Main circuit terminal block	Series	Main circuit terminal block																																																	
MR-J3-700_4	<p>TE1</p> <table border="1"> <tr> <td>L₁</td> <td>L₂</td> <td>L₃</td> <td>P</td> <td>C</td> <td>U</td> <td>V</td> <td>W</td> </tr> </table> <p>TE2</p> <table border="1"> <tr> <td>L₁₁</td> <td>L₂₁</td> </tr> </table> <p>TE3</p> <table border="1"> <tr> <td>N</td> <td>P₁</td> <td>P₂</td> </tr> </table> <p>PE terminal</p>  <p>TE1 Screw size: M4 Tightening torque: 1.2 [N•m] (10.6 [lb•in])</p> <p>TE2 Screw size: M3.5 (Note) Tightening torque: 0.8 [N•m] (7.08 [lb•in])</p> <p>TE3 Screw size: M4 Tightening torque: 1.2 [N•m] (10.6 [lb•in])</p> <p>PE Screw size: M4 Tightening torque: 1.2 [N•m] (10.6 [lb•in])</p>	L ₁	L ₂	L ₃	P	C	U	V	W	L ₁₁	L ₂₁	N	P ₁	P ₂	MR-J4-700_4 (-RJ)	<p>TE3</p> <table border="1"> <tr> <td>N</td> <td>P3</td> <td>P4</td> </tr> </table> <p>TE1</p> <table border="1"> <tr> <td>L₁</td> <td>L₂</td> <td>L₃</td> <td>P+</td> <td>C</td> <td>U</td> <td>V</td> <td>W</td> </tr> </table> <p>TE2</p> <table border="1"> <tr> <td>L₁₁</td> <td>L₂₁</td> </tr> </table> <p>PE</p>  <p>TE3 Screw size: M4 Tightening torque: 1.2 [N•m]</p> <p>TE1 Screw size: M4 Tightening torque: 1.2 [N•m]</p> <p>TE2 Screw size: M3.5 Tightening torque: 0.8 [N•m]</p> <p>PE Screw size: M4 Tightening torque: 1.2 [N•m]</p>	N	P3	P4	L ₁	L ₂	L ₃	P+	C	U	V	W	L ₁₁	L ₂₁																							
L ₁	L ₂	L ₃	P	C	U	V	W																																													
L ₁₁	L ₂₁																																																			
N	P ₁	P ₂																																																		
N	P3	P4																																																		
L ₁	L ₂	L ₃	P+	C	U	V	W																																													
L ₁₁	L ₂₁																																																			
MR-J3-11K_4 (-LR), MR-J3-15K_4 (-LR)	<p>TE</p> <table border="1"> <tr> <td>L₁</td> <td>L₂</td> <td>L₃</td> <td>L₁₁</td> <td>L₂₁</td> <td>U</td> <td>V</td> <td>W</td> </tr> <tr> <td>P₁</td> <td>P</td> <td>C</td> <td>N</td> <td></td> <td></td> <td></td> <td></td> </tr> </table> <table border="1"> <thead> <tr> <th></th> <th></th> <th>L₁/L₂/L₃/U/V/W/P₁/P/C/N/⊕</th> <th>L₁₁/L₂₁</th> </tr> </thead> <tbody> <tr> <td>MR-J3-11K_4</td> <td>Screw size</td> <td>M6</td> <td>M4</td> </tr> <tr> <td>MR-J3-15K_4</td> <td>Tightening torque [(lb•in)] [N•m]</td> <td>3.0</td> <td>1.2</td> </tr> <tr> <td>MR-J3-22K_4</td> <td>Screw size</td> <td>M8</td> <td>M4</td> </tr> <tr> <td>MR-J3-22K_4</td> <td>Tightening torque [(lb•in)] [N•m]</td> <td>6.0</td> <td>1.2</td> </tr> </tbody> </table>	L ₁	L ₂	L ₃	L ₁₁	L ₂₁	U	V	W	P ₁	P	C	N							L ₁ /L ₂ /L ₃ /U/V/W/P ₁ /P/C/N/⊕	L ₁₁ /L ₂₁	MR-J3-11K_4	Screw size	M6	M4	MR-J3-15K_4	Tightening torque [(lb•in)] [N•m]	3.0	1.2	MR-J3-22K_4	Screw size	M8	M4	MR-J3-22K_4	Tightening torque [(lb•in)] [N•m]	6.0	1.2	MR-J4-11K_4 (-RJ) MR-J4-15K_4 (-RJ)	<p>TE1-1</p> <table border="1"> <tr> <td>L₁</td> <td>L₂</td> <td>L₃</td> <td>U</td> <td>V</td> <td>W</td> </tr> </table> <p>TE1-2</p> <table border="1"> <tr> <td>P3</td> <td>P4</td> <td>P+</td> <td>C</td> <td>N</td> </tr> </table> <p>TE2</p> <table border="1"> <tr> <td>L₁₁</td> <td>L₂₁</td> </tr> </table> <p>PE</p>  <p>TE1-1 Screw size: M6 Tightening torque: 3.0 [N•m]</p> <p>TE1-2 Screw size: M6 Tightening torque: 3.0 [N•m]</p> <p>TE2 Screw size: M4 Tightening torque: 1.2 [N•m]</p> <p>PE Screw size: M6 Tightening torque: 3.0 [N•m]</p>	L ₁	L ₂	L ₃	U	V	W	P3	P4	P+	C	N	L ₁₁	L ₂₁
L ₁	L ₂	L ₃	L ₁₁	L ₂₁	U	V	W																																													
P ₁	P	C	N																																																	
		L ₁ /L ₂ /L ₃ /U/V/W/P ₁ /P/C/N/⊕	L ₁₁ /L ₂₁																																																	
MR-J3-11K_4	Screw size	M6	M4																																																	
MR-J3-15K_4	Tightening torque [(lb•in)] [N•m]	3.0	1.2																																																	
MR-J3-22K_4	Screw size	M8	M4																																																	
MR-J3-22K_4	Tightening torque [(lb•in)] [N•m]	6.0	1.2																																																	
L ₁	L ₂	L ₃	U	V	W																																															
P3	P4	P+	C	N																																																
L ₁₁	L ₂₁																																																			
MR-J3-22K_4	<p>TE</p> <table border="1"> <tr> <td>L₁</td> <td>L₂</td> <td>L₃</td> <td>L₁₁</td> <td>L₂₁</td> <td>U</td> <td>V</td> <td>W</td> </tr> <tr> <td>P₁</td> <td>P</td> <td>C</td> <td>N</td> <td></td> <td></td> <td></td> <td></td> </tr> </table> <table border="1"> <thead> <tr> <th></th> <th></th> <th>L₁/L₂/L₃/U/V/W/P₁/P/C/N/⊕</th> <th>L₁₁/L₂₁</th> </tr> </thead> <tbody> <tr> <td>MR-J3-11K_4</td> <td>Screw size</td> <td>M6</td> <td>M4</td> </tr> <tr> <td>MR-J3-15K_4</td> <td>Tightening torque [(lb•in)] [N•m]</td> <td>3.0</td> <td>1.2</td> </tr> <tr> <td>MR-J3-22K_4</td> <td>Screw size</td> <td>M8</td> <td>M4</td> </tr> <tr> <td>MR-J3-22K_4</td> <td>Tightening torque [(lb•in)] [N•m]</td> <td>6.0</td> <td>1.2</td> </tr> </tbody> </table>	L ₁	L ₂	L ₃	L ₁₁	L ₂₁	U	V	W	P ₁	P	C	N							L ₁ /L ₂ /L ₃ /U/V/W/P ₁ /P/C/N/⊕	L ₁₁ /L ₂₁	MR-J3-11K_4	Screw size	M6	M4	MR-J3-15K_4	Tightening torque [(lb•in)] [N•m]	3.0	1.2	MR-J3-22K_4	Screw size	M8	M4	MR-J3-22K_4	Tightening torque [(lb•in)] [N•m]	6.0	1.2	MR-J4-22K_4 (-RJ)	<p>TE1-1</p> <table border="1"> <tr> <td>L₁</td> <td>L₂</td> <td>L₃</td> <td>U</td> <td>V</td> <td>W</td> </tr> </table> <p>TE1-2</p> <table border="1"> <tr> <td>P3</td> <td>P4</td> <td>P+</td> <td>C</td> <td>N</td> </tr> </table> <p>TE2</p> <table border="1"> <tr> <td>L₁₁</td> <td>L₂₁</td> </tr> </table> <p>PE</p>  <p>TE1-1 Screw size: M8 Tightening torque: 6.0 [N•m]</p> <p>TE1-2 Screw size: M8 Tightening torque: 6.0 [N•m]</p> <p>TE2 Screw size: M4 Tightening torque: 1.2 [N•m]</p> <p>PE Screw size: M8 Tightening torque: 6.0 [N•m]</p>	L ₁	L ₂	L ₃	U	V	W	P3	P4	P+	C	N	L ₁₁	L ₂₁
L ₁	L ₂	L ₃	L ₁₁	L ₂₁	U	V	W																																													
P ₁	P	C	N																																																	
		L ₁ /L ₂ /L ₃ /U/V/W/P ₁ /P/C/N/⊕	L ₁₁ /L ₂₁																																																	
MR-J3-11K_4	Screw size	M6	M4																																																	
MR-J3-15K_4	Tightening torque [(lb•in)] [N•m]	3.0	1.2																																																	
MR-J3-22K_4	Screw size	M8	M4																																																	
MR-J3-22K_4	Tightening torque [(lb•in)] [N•m]	6.0	1.2																																																	
L ₁	L ₂	L ₃	U	V	W																																															
P3	P4	P+	C	N																																																
L ₁₁	L ₂₁																																																			
MR-J3-DU30K_4 MR-J3-DU37K_4	<p>TE2</p> <table border="1"> <tr> <td>L+</td> </tr> <tr> <td>L-</td> </tr> </table> <p>TE3</p> <table border="1"> <tr> <td>L₁₁</td> <td>L₂₁</td> </tr> </table> <p>TE1</p> <table border="1"> <tr> <td>U</td> <td>V</td> <td>W</td> </tr> </table> <p>PE</p>  <p>TE2 Screw size M6 Tightening torque: 3.0 [N•m] (26.6 [lb•in])</p> <p>TE3 Screw size M4 Tightening torque: 1.2 [N•m] (10.6 [lb•in])</p> <p>TE1 Screw size M8 Tightening torque: 6.0 [N•m] (53.1 [lb•in])</p> <p>PE Screw size M8 Tightening torque: 6.0 [N•m] (53.1 [lb•in])</p>	L+	L-	L ₁₁	L ₂₁	U	V	W	MR-J4-DU30K_4 MR-J4-DU37K_4	<p>TE2</p> <table border="1"> <tr> <td>L+</td> </tr> <tr> <td>L-</td> </tr> </table> <p>TE3</p> <table border="1"> <tr> <td>L₁₁</td> <td>L₂₁</td> </tr> </table> <p>TE1</p> <table border="1"> <tr> <td>U</td> <td>V</td> <td>W</td> </tr> </table> <p>PE</p>  <p>TE1 Screw size: M8 Tightening torque: 6.0 [N•m]</p> <p>TE2 Screw size: M6 Tightening torque: 3.0 [N•m]</p> <p>TE3 Screw size: M4 Tightening torque: 1.2 [N•m]</p> <p>PE Screw size: M8 Tightening torque: 6.0 [N•m]</p>	L+	L-	L ₁₁	L ₂₁	U	V	W																																			
L+																																																				
L-																																																				
L ₁₁	L ₂₁																																																			
U	V	W																																																		
L+																																																				
L-																																																				
L ₁₁	L ₂₁																																																			
U	V	W																																																		

Part 8: Common Reference Material

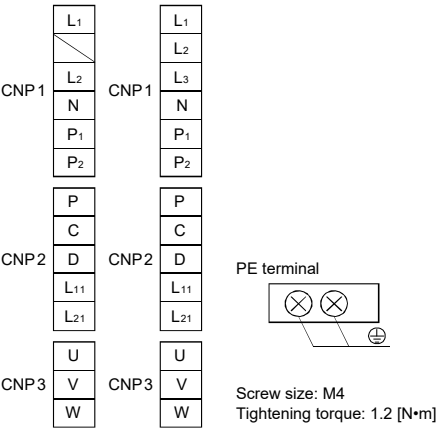
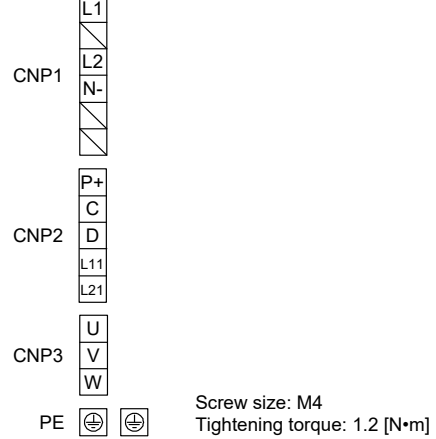
Series	Main circuit terminal block	Series	Main circuit terminal block
<p>MR-J3-10_1 to MR-J3-40_1</p>	 <p>PE terminal</p> <p>Screw size: M4 Tightening torque: 1.2 [N·m]</p>	<p>MR-J4-10_1(-RJ) to MR-J4-40_1(-RJ)</p>	 <p>Screw size: M4 Tightening torque: 1.2 [N·m]</p>

Note Screw size is M3.5 for the control circuit terminal block (TE2) of the servo amplifier manufactured in April 2007 or later. Screw size is M3 for the control terminal block (TE2) of the servo amplifier manufactured in March 2007 or earlier.

Part 8: Common Reference Material

1.2.2 Comparison of encoder signals (CN2)

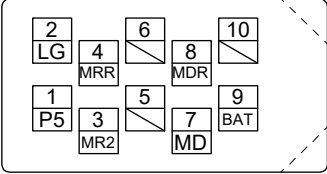
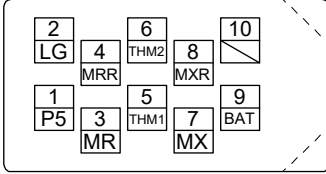
MR-J3/J3W series		Signal symbol (Note 1)	MR-J4 series	
Connector pin assignment	Connector pin No.		Connector pin No.	Connector pin assignment
	CN2-2	LG	CN2-2	
	CN2-7	MD (MX)	CN2-7	
	CN2-3	MR	CN2-3	
	CN2-9	BAT	CN2-9	
	CN2-8	MDR (MXR)	CN2-8	
	CN2-4	MRR	CN2-4	
CN2-1	P5	CN2-1		

Note 1. Signal abbreviations in parentheses are for MR-J4 series.

Note 2. THM1 and THM2 depend on the servo motor used. Refer to "Part 9 Review on Replacement of Motor".

Part 8: Common Reference Material

1.2.3 Dynamic brake: coasting distance

(1) Dynamic brake time constant

(a) Replacement of MR-J3 Series with MR-J4 Series

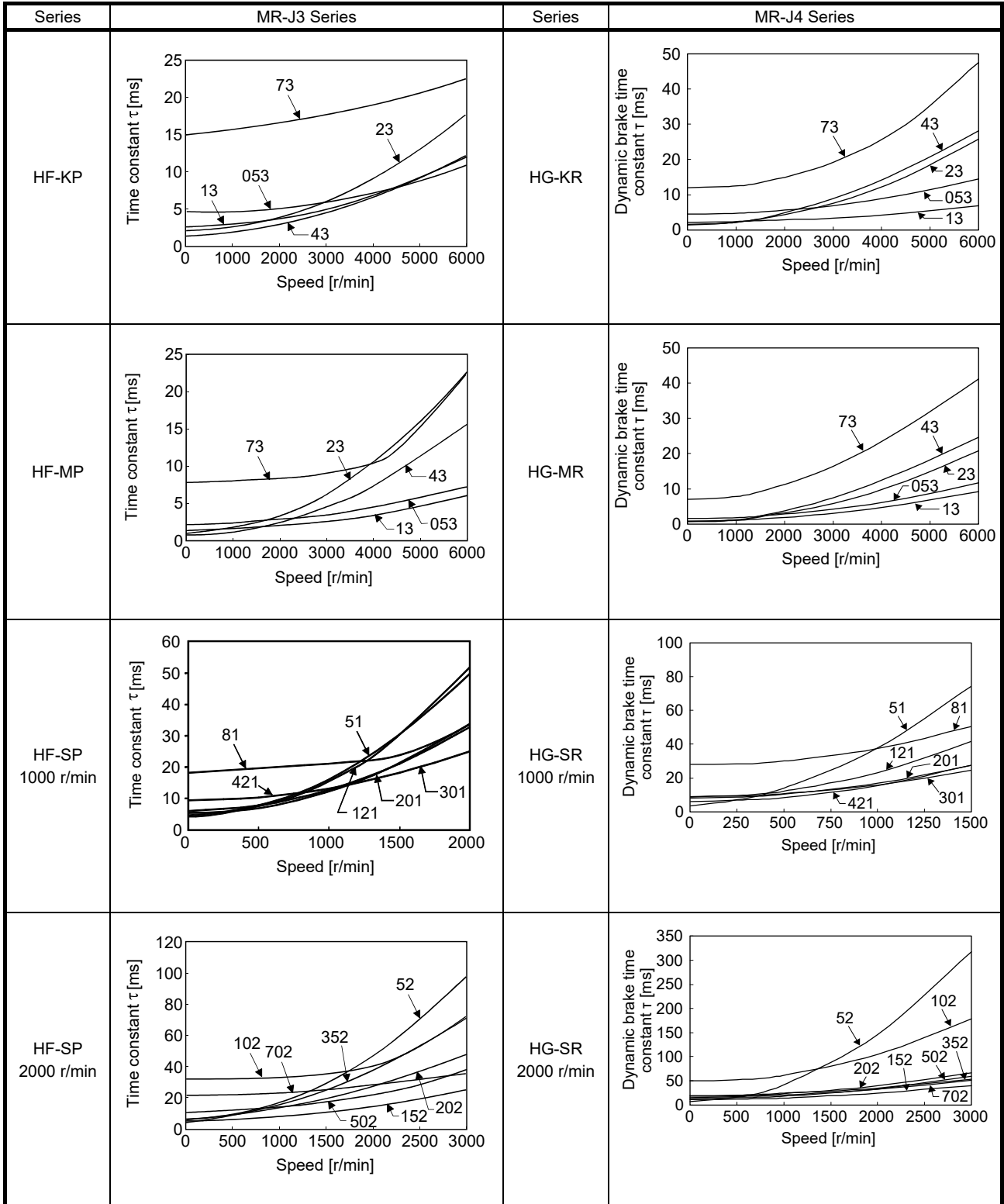

Part 8: Common Reference Material

Series	MR-J3 Series	Series	MR-J4 Series
HF-SP 400 V 2000 r/min		HG-SR 400 V 2000 r/min	
HC-RP		HG-RR	
HF-JP 200 V		HG-JR 200 V	
HF-JP 400 V		HG-JR 400 V	

Part 8: Common Reference Material

Series	MR-J3 Series	Series	MR-J4 Series
<p>HC-LP 2000 r/min</p>		<p>HG-JR 3000 r/min</p>	
<p>HC-UP</p>		<p>HG-UR</p>	
<p>HA-LP 200 V</p>		<p>HG-SR 200 V</p>	
		<p>HG-JR 200 V 1500 r/min</p>	

Part 8: Common Reference Material

Series	MR-J3 Series	Series	MR-J4 Series
HA-LP 400 V 1500 r/min		HG-JR 400 V 1500 r/min	
HA-LP 400 V 2000 r/min			
HF-JP 200 V		HG-JR 200 V	
HF-JP 400 V		HG-JR 400 V	

Part 8: Common Reference Material

Series	MR-J3 Series	Series	MR-J4 Series
<p>HA-LP 200 V 1000 r/min</p>		<p>HG-JR 200 V 1000 r/min</p>	
<p>HA-LP 200 V 1500 r/min</p>		<p>HG-JR 200 V 1500 r/min</p>	
<p>HA-LP 200 V 2000 r/min</p>			

Part 8: Common Reference Material

Series	MR-J3 Series	Series	MR-J4 Series
<p>HA-LP 400 V 1000 r/min</p>		<p>HG-JR 400 V 1000 r/min</p>	
<p>HA-LP 400 V 1500 r/min</p>		<p>HG-JR 400 V 1500 r/min</p>	
<p>HA-LP 400 V 2000 r/min</p>			

Part 8: Common Reference Material

(b) Replacement of MR-J3W Series with MR-J4W2-_B servo amplifier

Series	MR-J3W Series	Series	MR-J4W2-_B
HF-KP		HG-KR	
HF-MP		HG-MR	
HF-SP 1000 r/min		HG-SR 1000 r/min	
HF-SP 2000 r/min		HG-SR 2000 r/min	

Part 8: Common Reference Material

Series	MR-J3W Series	Series	MR-J4W2-_B
HC-UP series		HG-UR series	
HF-JP 3000 r/min		HG-JR 3000 r/min	
HC-LP series			
HG-AK series		HG-AK series	

Part 8: Common Reference Material

(2) Calculation of coasting distance

The figure shows the pattern in which the servo motor comes to a stop when the dynamic brake is operated. Use equation 5.1 to calculate an approximate coasting distance to a stop. The dynamic brake time constant τ varies with the servo motor and machine operation speeds. (Refer to (1) of this section.) A working part generally has a friction force. Therefore, actual coasting distance will be shorter than a maximum coasting distance calculated with the following equation.

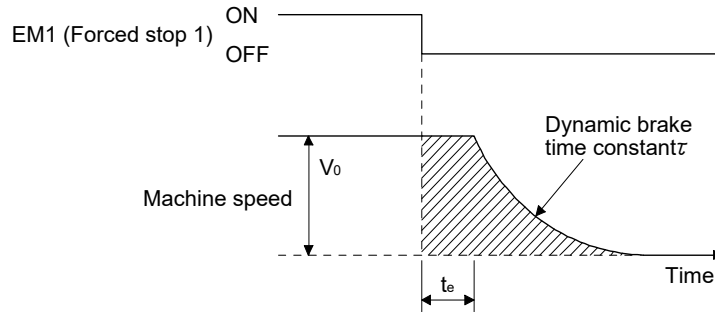

Dynamic Brake Operation Diagram

$$L_{\max} = \frac{V_0}{60} \cdot \left\{ t_e + \tau \left(1 + \frac{J_L}{J_M} \right) \right\} \dots \dots \dots (7.1)$$

- L_{\max} : Maximum coasting distance [mm]
- V_0 : Machine's fast feed speed [mm/min]
- J_M : Moment of inertia of the servo motor [$\times 10^{-4}$ kg \cdot m²]
- J_L : Load moment of inertia converted into equivalent value on servo motor shaft [$\times 10^{-4}$ kg \cdot m²]
- τ : Dynamic brake time constant [s]
- t_e : Delay time of control section [s]

For 7 kW or lower servo, there is internal relay delay time of about 10 ms. For 11 kW to 55 kW servo, there is delay caused by magnetic contactor built into the external dynamic brake (about 50 ms) and delay caused by the external relay.

For MR-J3W-0303BN6 and MR-J4W2-0303B6 the processing delay time about 3.5 ms

Part 8: Common Reference Material

(3) Electronic dynamic brake

The electronic dynamic brake operates in the initial state for HG series servo motors with a 600 W or smaller capacity.

The time constant " τ " for the electronic dynamic brake will be shorter than that for normal dynamic brake. Therefore, coasting distance will be shorter than in normal dynamic brake.

Series	Servo motor
HG-KR	HG-KR053/HG-KR13/HG-KR23/HG-KR43
HG-MR	HG-MR053/HG-MR13/HG-MR23/HG-MR43
HG-SR	HG-SR51/HG-SR52
HG-AK	HG-AK0136/HG-AK0236/HG-AK0336

(a) Parameter settings (for MR-J4- _A_ series)

No.	Abbreviation	Name and function	Initial value [unit]	Setting range														
PF09	*FOP5	Function selection F-5 <table border="1" style="width: 100%; border-collapse: collapse;"> <thead> <tr> <th>Setting digit</th> <th>Explanation</th> <th>Initial value</th> </tr> </thead> <tbody> <tr> <td>___x</td> <td>Electronic dynamic brake selection. 0: Automatic (effective only for specific servo motors) 2: Disabled Refer to the following table for the specified servo motors. <table border="1" style="width: 100%; border-collapse: collapse;"> <thead> <tr> <th>Series</th> <th>Servo motor</th> </tr> </thead> <tbody> <tr> <td>HG-KR</td> <td>HG-KR053/HG-KR13/HG-KR23/HG-KR43</td> </tr> <tr> <td>HG-MR</td> <td>HG-MR053/HG-MR13/HG-MR23/HG-MR43</td> </tr> <tr> <td>HG-SR</td> <td>HG-SR51/HG-SR52</td> </tr> </tbody> </table> </td> <td>0h</td> </tr> </tbody> </table>	Setting digit	Explanation	Initial value	___x	Electronic dynamic brake selection. 0: Automatic (effective only for specific servo motors) 2: Disabled Refer to the following table for the specified servo motors. <table border="1" style="width: 100%; border-collapse: collapse;"> <thead> <tr> <th>Series</th> <th>Servo motor</th> </tr> </thead> <tbody> <tr> <td>HG-KR</td> <td>HG-KR053/HG-KR13/HG-KR23/HG-KR43</td> </tr> <tr> <td>HG-MR</td> <td>HG-MR053/HG-MR13/HG-MR23/HG-MR43</td> </tr> <tr> <td>HG-SR</td> <td>HG-SR51/HG-SR52</td> </tr> </tbody> </table>	Series	Servo motor	HG-KR	HG-KR053/HG-KR13/HG-KR23/HG-KR43	HG-MR	HG-MR053/HG-MR13/HG-MR23/HG-MR43	HG-SR	HG-SR51/HG-SR52	0h	Refer to the "Name and function" column.	
Setting digit	Explanation	Initial value																
___x	Electronic dynamic brake selection. 0: Automatic (effective only for specific servo motors) 2: Disabled Refer to the following table for the specified servo motors. <table border="1" style="width: 100%; border-collapse: collapse;"> <thead> <tr> <th>Series</th> <th>Servo motor</th> </tr> </thead> <tbody> <tr> <td>HG-KR</td> <td>HG-KR053/HG-KR13/HG-KR23/HG-KR43</td> </tr> <tr> <td>HG-MR</td> <td>HG-MR053/HG-MR13/HG-MR23/HG-MR43</td> </tr> <tr> <td>HG-SR</td> <td>HG-SR51/HG-SR52</td> </tr> </tbody> </table>	Series	Servo motor	HG-KR	HG-KR053/HG-KR13/HG-KR23/HG-KR43	HG-MR	HG-MR053/HG-MR13/HG-MR23/HG-MR43	HG-SR	HG-SR51/HG-SR52	0h								
Series	Servo motor																	
HG-KR	HG-KR053/HG-KR13/HG-KR23/HG-KR43																	
HG-MR	HG-MR053/HG-MR13/HG-MR23/HG-MR43																	
HG-SR	HG-SR51/HG-SR52																	
PF15	DBT	Electronic Dynamic Brake Operating Time Set an operating time for the electronic dynamic brake. (Note)	2000 [ms]	0 to 10000														

(b) Parameter settings (for MR-J4- _B_ series/MR-J4W2- _B_ servo amplifier/MR-J4- _GF_ series)

No.	Abbreviation	Name and function	Initial value [unit]	Setting range																
PF06	*FOP5	Function selection F-5 <table border="1" style="width: 100%; border-collapse: collapse;"> <thead> <tr> <th>Setting digit</th> <th>Explanation</th> <th>Initial value</th> </tr> </thead> <tbody> <tr> <td>___x</td> <td>Electronic dynamic brake selection. 0: Automatic (effective only for specific servo motors) 2: Disabled Refer to the following table for the specified servo motors. <table border="1" style="width: 100%; border-collapse: collapse;"> <thead> <tr> <th>Series</th> <th>Servo motor</th> </tr> </thead> <tbody> <tr> <td>HG-KR</td> <td>HG-KR053/HG-KR13/HG-KR23/HG-KR43</td> </tr> <tr> <td>HG-MR</td> <td>HG-MR053/HG-MR13/HG-MR23/HG-MR43</td> </tr> <tr> <td>HG-SR</td> <td>HG-SR51/HG-SR52</td> </tr> <tr> <td>HG-AK</td> <td>HG-AK0136/HG-AK0236/HG-AK0336</td> </tr> </tbody> </table> </td> <td>0h</td> </tr> </tbody> </table>	Setting digit	Explanation	Initial value	___x	Electronic dynamic brake selection. 0: Automatic (effective only for specific servo motors) 2: Disabled Refer to the following table for the specified servo motors. <table border="1" style="width: 100%; border-collapse: collapse;"> <thead> <tr> <th>Series</th> <th>Servo motor</th> </tr> </thead> <tbody> <tr> <td>HG-KR</td> <td>HG-KR053/HG-KR13/HG-KR23/HG-KR43</td> </tr> <tr> <td>HG-MR</td> <td>HG-MR053/HG-MR13/HG-MR23/HG-MR43</td> </tr> <tr> <td>HG-SR</td> <td>HG-SR51/HG-SR52</td> </tr> <tr> <td>HG-AK</td> <td>HG-AK0136/HG-AK0236/HG-AK0336</td> </tr> </tbody> </table>	Series	Servo motor	HG-KR	HG-KR053/HG-KR13/HG-KR23/HG-KR43	HG-MR	HG-MR053/HG-MR13/HG-MR23/HG-MR43	HG-SR	HG-SR51/HG-SR52	HG-AK	HG-AK0136/HG-AK0236/HG-AK0336	0h	Refer to the "Name and function" column.	
Setting digit	Explanation	Initial value																		
___x	Electronic dynamic brake selection. 0: Automatic (effective only for specific servo motors) 2: Disabled Refer to the following table for the specified servo motors. <table border="1" style="width: 100%; border-collapse: collapse;"> <thead> <tr> <th>Series</th> <th>Servo motor</th> </tr> </thead> <tbody> <tr> <td>HG-KR</td> <td>HG-KR053/HG-KR13/HG-KR23/HG-KR43</td> </tr> <tr> <td>HG-MR</td> <td>HG-MR053/HG-MR13/HG-MR23/HG-MR43</td> </tr> <tr> <td>HG-SR</td> <td>HG-SR51/HG-SR52</td> </tr> <tr> <td>HG-AK</td> <td>HG-AK0136/HG-AK0236/HG-AK0336</td> </tr> </tbody> </table>	Series	Servo motor	HG-KR	HG-KR053/HG-KR13/HG-KR23/HG-KR43	HG-MR	HG-MR053/HG-MR13/HG-MR23/HG-MR43	HG-SR	HG-SR51/HG-SR52	HG-AK	HG-AK0136/HG-AK0236/HG-AK0336	0h								
Series	Servo motor																			
HG-KR	HG-KR053/HG-KR13/HG-KR23/HG-KR43																			
HG-MR	HG-MR053/HG-MR13/HG-MR23/HG-MR43																			
HG-SR	HG-SR51/HG-SR52																			
HG-AK	HG-AK0136/HG-AK0236/HG-AK0336																			
PF12	DBT	Electronic Dynamic Brake Operating Time Set an operating time for the electronic dynamic brake. (Note)	2000 [ms]	0 to 10000																

Note. When the electronic dynamic brake is released during operation, the servo system cannot be switched on until the, [Pr. PF12] operating time is over.

Part 8: Common Reference Material

1.2.4 Forced stop deceleration function selection

(1) Parameter setting

(a) For MR-J4-_A_series

POINT

- With MR-J4-_A_, the deceleration to a stop function is enabled by the factory setting. To disable the deceleration to a stop function, set [Pr. PA04] to "0 ___".

No.	Abbreviation	Name and function	Initial value [unit]	Setting range																											
PA04	*AOP1	Function selection A-1 This is used to select the forced stop input and forced stop deceleration function. <table border="1" data-bbox="352 741 1201 1021"> <thead> <tr> <th>Setting digit</th> <th>Explanation</th> <th>Initial value</th> </tr> </thead> <tbody> <tr> <td>___x</td> <td rowspan="3">For manufacturer setting</td> <td>0h</td> </tr> <tr> <td>__x_</td> <td>0h</td> </tr> <tr> <td>_x__</td> <td>0h</td> </tr> <tr> <td>x___</td> <td> Forced stop deceleration function selection 0: Forced stop deceleration function disabled (EM1) 2: Forced stop deceleration function enabled (EM2) Refer to the following table for details. </td> <td>2h</td> </tr> </tbody> </table> <table border="1" data-bbox="352 1055 1201 1290"> <thead> <tr> <th rowspan="2">Setting value</th> <th rowspan="2">EM2/EM1 selection</th> <th colspan="2">Deceleration method</th> </tr> <tr> <th>EM2 or EM1 is off</th> <th>Alarm occurred</th> </tr> </thead> <tbody> <tr> <td>0 ___</td> <td>EM1</td> <td>MBR (Electromagnetic brake interlock) turns off without the forced stop deceleration.</td> <td>MBR (Electromagnetic brake interlock) turns off without the forced stop deceleration.</td> </tr> <tr> <td>2 ___</td> <td>EM2</td> <td>MBR (Electromagnetic brake interlock) turns off after the forced stop deceleration.</td> <td>MBR (Electromagnetic brake interlock) turns off after the forced stop deceleration.</td> </tr> </tbody> </table>	Setting digit	Explanation	Initial value	___x	For manufacturer setting	0h	__x_	0h	_x__	0h	x___	Forced stop deceleration function selection 0: Forced stop deceleration function disabled (EM1) 2: Forced stop deceleration function enabled (EM2) Refer to the following table for details.	2h	Setting value	EM2/EM1 selection	Deceleration method		EM2 or EM1 is off	Alarm occurred	0 ___	EM1	MBR (Electromagnetic brake interlock) turns off without the forced stop deceleration.	MBR (Electromagnetic brake interlock) turns off without the forced stop deceleration.	2 ___	EM2	MBR (Electromagnetic brake interlock) turns off after the forced stop deceleration.	MBR (Electromagnetic brake interlock) turns off after the forced stop deceleration.	Refer to the "Name and function" column.	
Setting digit	Explanation	Initial value																													
___x	For manufacturer setting	0h																													
__x_		0h																													
_x__		0h																													
x___	Forced stop deceleration function selection 0: Forced stop deceleration function disabled (EM1) 2: Forced stop deceleration function enabled (EM2) Refer to the following table for details.	2h																													
Setting value	EM2/EM1 selection	Deceleration method																													
		EM2 or EM1 is off	Alarm occurred																												
0 ___	EM1	MBR (Electromagnetic brake interlock) turns off without the forced stop deceleration.	MBR (Electromagnetic brake interlock) turns off without the forced stop deceleration.																												
2 ___	EM2	MBR (Electromagnetic brake interlock) turns off after the forced stop deceleration.	MBR (Electromagnetic brake interlock) turns off after the forced stop deceleration.																												

Part 8: Common Reference Material

(b) For MR-J4-_B_series/MR-J4W2-_B servo amplifier/MR-J4-_GF_series

POINT
<p>● With MR-J4-_B_, MR-J4W2-_B and MR-J4-_GF_series the deceleration to a stop function is enabled in the factory setting. To disable the deceleration to a stop function, set [Pr. PA04] to "0 ___".</p>

No.	Abbreviation	Name and function	Initial value [unit]	Setting range																																				
PA04	*AOP1	<p>Function selection A-1 This is used to select the forced stop input and forced stop deceleration function.</p> <table border="1" style="width: 100%; border-collapse: collapse;"> <thead> <tr> <th style="width: 15%;">Setting digit</th> <th style="width: 65%;">Explanation</th> <th style="width: 20%;">Initial value</th> </tr> </thead> <tbody> <tr> <td>___x</td> <td rowspan="2">For manufacturer setting</td> <td>0h</td> </tr> <tr> <td>__x_</td> <td>0h</td> </tr> <tr> <td>_x__</td> <td> Servo forced stop selection 0: Enabled (The forced stop input EM2 or EM1 is used.) 1: Disabled (The forced stop input EM2 and EM1 are not used.) Refer to the following table for details. </td> <td>0h</td> </tr> <tr> <td>x___</td> <td> Forced stop deceleration function selection 0: Forced stop deceleration function disabled (EM1) 2: Forced stop deceleration function enabled (EM2) Refer to the following table for details. </td> <td>2h</td> </tr> </tbody> </table> <table border="1" style="width: 100%; border-collapse: collapse;"> <thead> <tr> <th rowspan="2">Setting value</th> <th rowspan="2">EM2/EM1 selection</th> <th colspan="2">Deceleration method</th> </tr> <tr> <th>EM2 or EM1 is off</th> <th>Alarm occurred</th> </tr> </thead> <tbody> <tr> <td>00__</td> <td>EM1</td> <td>MBR (Electromagnetic brake interlock) turns off without the forced stop deceleration.</td> <td>MBR (Electromagnetic brake interlock) turns off without the forced stop deceleration.</td> </tr> <tr> <td>20__</td> <td>EM2</td> <td>MBR (Electromagnetic brake interlock) turns off after the forced stop deceleration.</td> <td>MBR (Electromagnetic brake interlock) turns off after the forced stop deceleration.</td> </tr> <tr> <td>01__</td> <td>Not using EM2 or EM1</td> <td style="text-align: center;">/</td> <td>MBR (Electromagnetic brake interlock) turns off without the forced stop deceleration.</td> </tr> <tr> <td>21__</td> <td>Not using EM2 or EM1</td> <td style="text-align: center;">/</td> <td>MBR (Electromagnetic brake interlock) turns off after the forced stop deceleration.</td> </tr> </tbody> </table>	Setting digit	Explanation	Initial value	___x	For manufacturer setting	0h	__x_	0h	_x__	Servo forced stop selection 0: Enabled (The forced stop input EM2 or EM1 is used.) 1: Disabled (The forced stop input EM2 and EM1 are not used.) Refer to the following table for details.	0h	x___	Forced stop deceleration function selection 0: Forced stop deceleration function disabled (EM1) 2: Forced stop deceleration function enabled (EM2) Refer to the following table for details.	2h	Setting value	EM2/EM1 selection	Deceleration method		EM2 or EM1 is off	Alarm occurred	00__	EM1	MBR (Electromagnetic brake interlock) turns off without the forced stop deceleration.	MBR (Electromagnetic brake interlock) turns off without the forced stop deceleration.	20__	EM2	MBR (Electromagnetic brake interlock) turns off after the forced stop deceleration.	MBR (Electromagnetic brake interlock) turns off after the forced stop deceleration.	01__	Not using EM2 or EM1	/	MBR (Electromagnetic brake interlock) turns off without the forced stop deceleration.	21__	Not using EM2 or EM1	/	MBR (Electromagnetic brake interlock) turns off after the forced stop deceleration.	Refer to the "Name and function" column	
Setting digit	Explanation	Initial value																																						
___x	For manufacturer setting	0h																																						
__x_		0h																																						
_x__	Servo forced stop selection 0: Enabled (The forced stop input EM2 or EM1 is used.) 1: Disabled (The forced stop input EM2 and EM1 are not used.) Refer to the following table for details.	0h																																						
x___	Forced stop deceleration function selection 0: Forced stop deceleration function disabled (EM1) 2: Forced stop deceleration function enabled (EM2) Refer to the following table for details.	2h																																						
Setting value	EM2/EM1 selection	Deceleration method																																						
		EM2 or EM1 is off	Alarm occurred																																					
00__	EM1	MBR (Electromagnetic brake interlock) turns off without the forced stop deceleration.	MBR (Electromagnetic brake interlock) turns off without the forced stop deceleration.																																					
20__	EM2	MBR (Electromagnetic brake interlock) turns off after the forced stop deceleration.	MBR (Electromagnetic brake interlock) turns off after the forced stop deceleration.																																					
01__	Not using EM2 or EM1	/	MBR (Electromagnetic brake interlock) turns off without the forced stop deceleration.																																					
21__	Not using EM2 or EM1	/	MBR (Electromagnetic brake interlock) turns off after the forced stop deceleration.																																					

Part 8: Common Reference Material

1.2.5 Servo setup software: Setup software (SETUP221E) => MR Configurator2

Item	MR-J3 series	→	MR-J4 series
Servo setup software	Setup software Model: MRZJW3-SETUP221E		MR Configurator2 Model: SW1DNC-MRC2-E

(1) MR Configurator2 (SW1DNC-MRC2-E) specification

Item	Description
Project	Create/read/save/delete project, system setting, and print
Parameter	Parameter setting, amplifier axis name setting, parameter converter (Note 1)
Positioning data	Point table, program, indirect addressing
Monitor	Display all, I/O monitor, graph, and ABS data display
Diagnostics	Alarm display, alarm onset data display, drive recorder, display of the reason for no rotation, system configuration, life diagnosis, machine diagnosis
Test operation	Jog operation (Note 1), positioning operation, motor-less operation, DO forced output, and program operation, test operation event information, single-step feed (Note 2)
Adjustment	One-touch tuning, tuning, and machine analyzer
Others	Servo assistant, parameter setting range update, help display, connection to MITSUBISHI ELECTRIC FA Global Website

- Note 1. This function is available only in standard control mode.
 Note 2. SW1DNC-MRC2-E supports only MR-J4_A_-RJ.

(2) System configuration

For servo setup software components, refer to each servo amplifier instruction manual.

Part 8: Common Reference Material

1.2.6 Servo amplifier initialization time

This section describes the servo amplifier initialization time (time from power-on to servo-on acceptance). The initialization time is about 2 s for the MR-J3- A servo amplifier, about 2.5 s for MR-J3- T , and about 3 s for the MR-J3- B /MR-J3W- B servo amplifier. In contrast, the initialization time is about 3.5 s for the MR-J4- A /MR-J4- B /MR-J4W2- B servo amplifier, about 4 s for MR-J4- A -RJ, and "about 4 s and network initial communication" for the MR-J4- GF servo amplifier. When replacing the servo amplifier, be careful of the difference in initialization time.

<Points to note upon replacement>

- (1) When using the electromagnetic brake to prevent a drop in a vertical lift application or the like with an external timer to adjust the brake release time, the lift may drop due to a longer servo-lock time. Adjust the brake release time as necessary or use MBR (electromagnetic brake interlock signal).
- (2) A longer servo-on time at power-on may cause a delay in the servo motor starting time after power-up. Please take note.

(1) MR-J3- A series servo amplifier

The initialization time is 1.5 to 2 s.

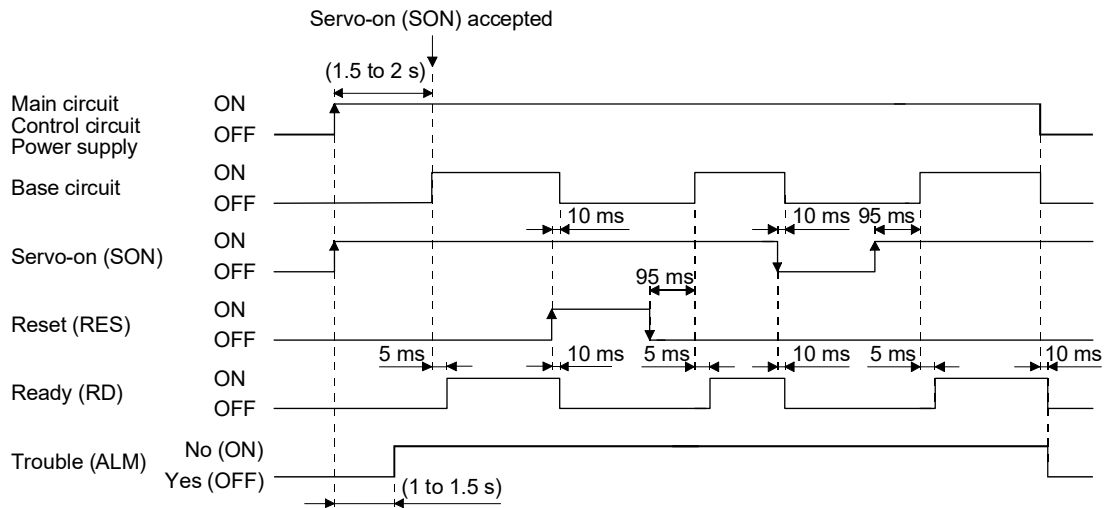

(2) MR-J4- A /MR-J4- B series servo amplifier/MR-J4W2- B servo amplifier

The initialization time is 2.5 to 3.5 s.

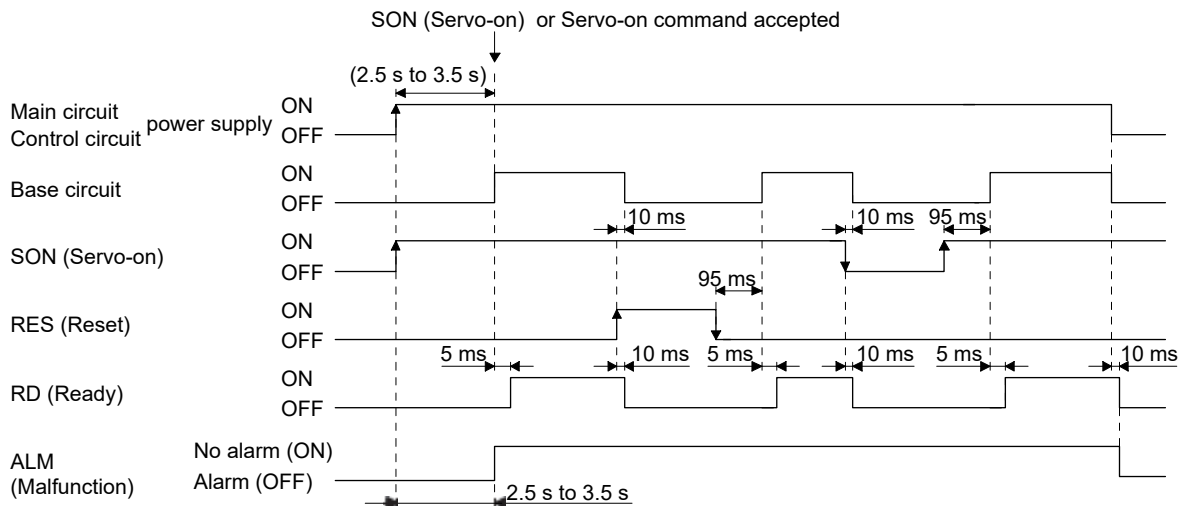

Part 8: Common Reference Material

(3) MR-J3-_B_/MR-J3W-_B series servo amplifier

The initialization time is 3 s.

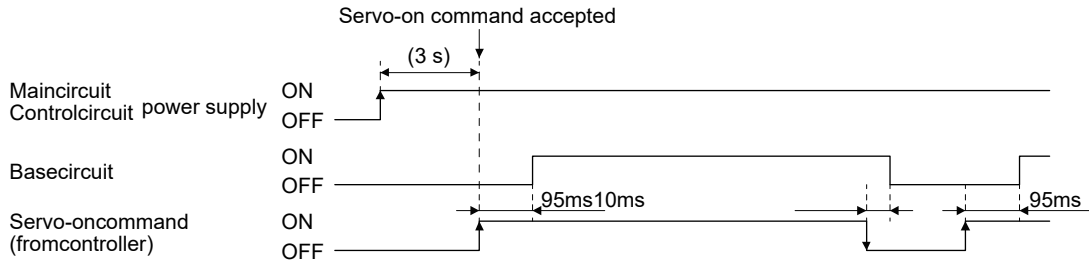

(4) MR-J4W2-0303B6 servo amplifier

The initialization time is 4 s.

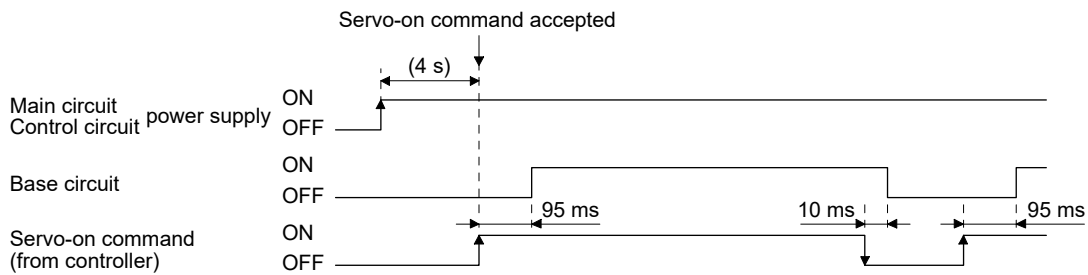

(5) MR-J3W-0303BN6 servo amplifier

The initialization time is 3 s.

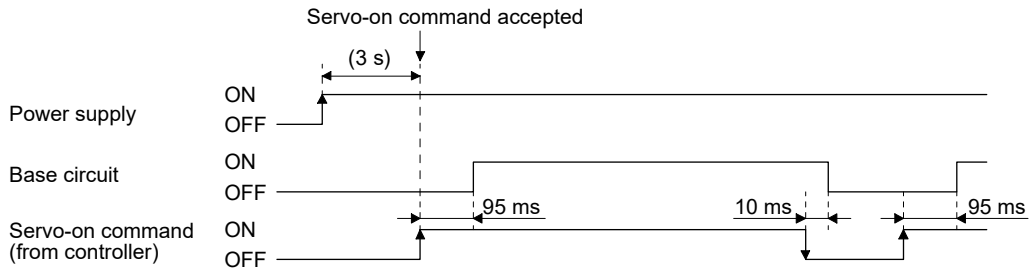

(6) MR-J3-_T_ series servo amplifier

The initialization time is 2 to 2.5 s.

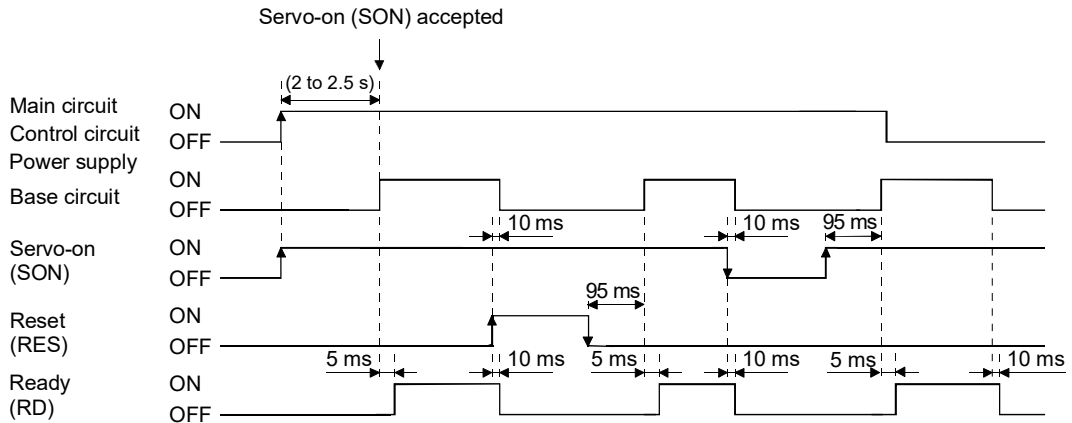

Part 8: Common Reference Material

(7) MR-J4-_A_-RJ series servo amplifier

The initialization time is 4 to 4.5 s.

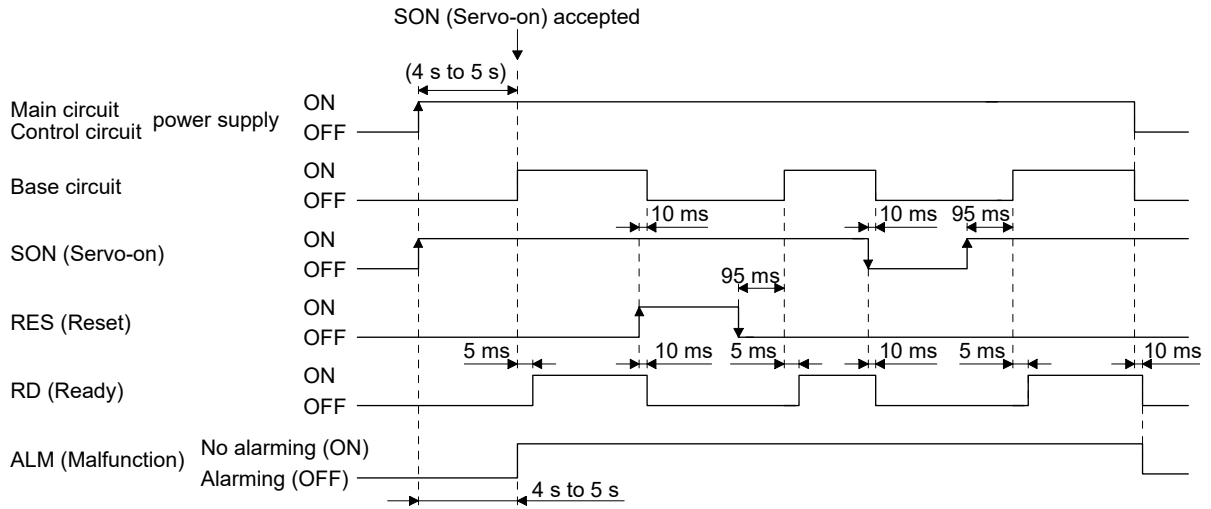

(8) MR-J4-_GF_ series servo amplifier

The initialization time is 3 s to 4 s and network initial communication time.

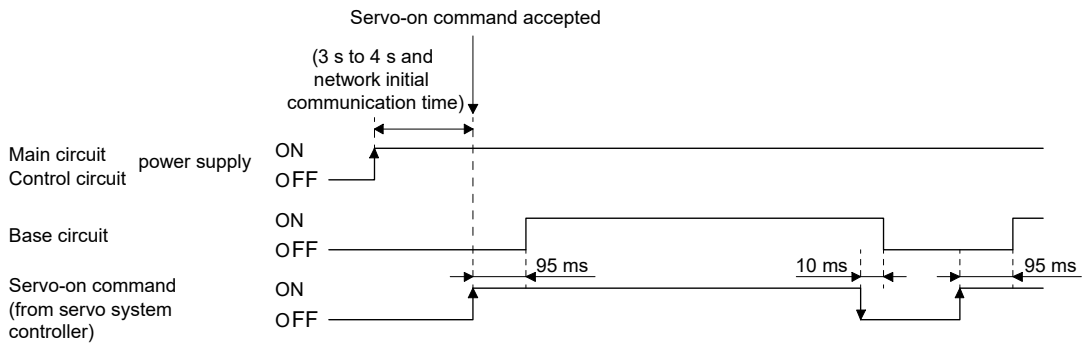

Part 8: Common Reference Material

1.2.7 The pulse width of the encoder Z-Phase pulse

< Precautions >

Always reset the home position upon replacement.

< Servo amplifier replacement >

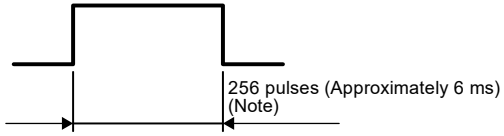
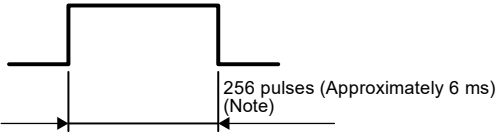
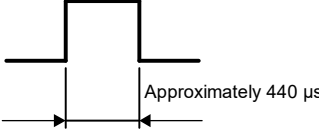
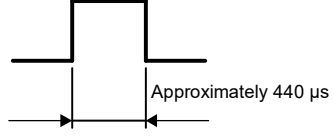
	MR-J3/MR-J3W series	MR-J4 series
At low speed Lower than approximately 130 r/min	256/262144 pulses (The number of Z-phase pulses/ The number of pulses per servo motor revolution) 	256/262144 pulses (The number of Z-phase pulses/ The number of pulses per servo motor revolution) 
At high speed Approximately 130 r/min or higher	Approximately 440 μs fixed 	Approximately 440 μs fixed 

Note. This is the pulse width when the servo motor rotates at 10 r/min. The time for the pulse width varies depending on the number of the servo motor revolutions.

$$\text{Pulse width} = 256 \times (60 / (\text{Servo motor speed} \times 262144)) \times 106 [\mu\text{s}]$$

< Simultaneous replacement >

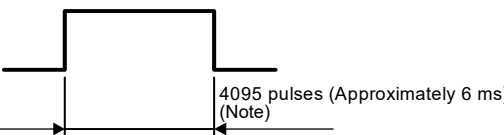
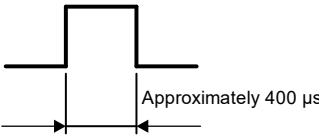
	HG-KR/HG-MR/HG-SR motor
At low speed Lower than approximately 130 r/min	4096/4194304 pulses (The number of Z-phase pulses/ The number of pulses per servo motor revolution) 
At high speed Approximately 130 r/min or higher	Approximately 400 μs fixed 

Note. This is the pulse width when the servo motor rotates at 10 r/min. The time for the pulse width varies depending on the number of the servo motor revolutions.

$$\text{Pulse width} = 4096 \times (60 / (\text{Servo motor speed} \times 4194304)) \times 106 [\mu\text{s}]$$

Part 8: Common Reference Material

1.3 Overload protection characteristics

POINT
<ul style="list-style-type: none">● "Overload protection characteristics" may be different due to the replacement of the servo amplifier and the servo motor. Check "overload protection characteristics" of each model before considering replacement.● If operation that generates torque more than 100% of the rating is performed with an abnormally high frequency in a servo motor stop status (servo-lock status) or in a 50 r/min or less (the other motors: 30 r/min or less) low-speed operation status, the servo amplifier may malfunction regardless of the electronic thermal protection.● When MR-J4 series is driven with motors before replacement, the "overload protection characteristics" is the same as MR-J3 series.

An electronic thermal is built in the servo amplifier to protect the servo motor, servo amplifier and servo motor power wires from overloads.

[AL. 50 Overload 1] occurs if overload operation performed is above the electronic thermal protection curve shown in fig. 10.1 [AL. 51 Overload 2] occurs if the maximum current is applied continuously for several seconds due to machine collision, etc. Use the equipment on the left-hand side area of the continuous or broken line in the graph.

For the system where the unbalanced torque occurs, such as a vertical axis system, the unbalanced torque of the machine should be kept at 70% or less of the rated torque.

This servo amplifier has solid-state servo motor overload protection.

Part 8: Common Reference Material

- (1) MR-J3 servo amplifier/MR-J4 servo amplifier
 · MR-J3 servo amplifier

Rotary servo motor								Graph of overload protection characteristics
HF-KP	HF-MP	HF-SP	HC-UP	HF-RP	HC-LP	HA-LP	HF-JP	
053 13	053 13							Characteristics a
23 43 73	23 43 73	51 81 52 102	72		52 102		53 73 103	Characteristics b
		121 201 152 202 301 352	152 202	103 153 203	152 202		153 203 353	Characteristics c
		421 502 702	352 502	353 503	302	502 601 701M 702	503 703	Characteristics d
						801 11K1M 11K2 15K1 15K1M 15K2 20K1 22K1M 22K2 25K1	903 11K1M (Note) 15K1M (Note)	Characteristics e
		524 1024					534 734 1034	Characteristics b
		1524 2024 3524					1534 2034 3534	Characteristics c
		5024 7024				6014 701M4	5034 7034	Characteristics d
						8014 11K1M4 11K24 12K14 15K14 15K1M4 15K24 20K14 22K1M4 22K24	9034 11K1M4 (Note) 15K1M4 (Note)	Characteristics e

Note. Model names of servo amplifiers supporting these servo motors have "-LR" at the end.

Part 8: Common Reference Material

Servo amplifiers supporting the 400% maximum torque setting (Note 1)	Servo motor (Note 2)
	HF-JP
MR-J3-100_	53
MR-J3-200_N	73
	103
MR-J3-350_	153
	203
MR-J3-500_	353
MR-J3-700_	503

Servo amplifiers supporting the 400% maximum torque setting (Note 1)	Servo motor (Note 2)
	HF-JP
MR-J3-100_4	534
MR-J3-200_4	734
	1034
MR-J3-350_4	1534
	2034
MR-J3-500_4	3534
MR-J3-700_4	5034

- Note 1. The following shows the software versions of the servo amplifiers for increasing the maximum torque up to 400%.
- MR-J3-_A_: Manufactured in January 2010 or later (software version C6 or later)
 - MR-J3-_B_: Manufactured in August 2009 or later (software version C4 or later)
 - MR-J3-_T_: Manufactured in April 2010 or later (software version A8 or later)
2. The maximum torque of the HF-JP servo motor can be increased up to 400% by using a servo amplifier manufactured in April 2010 or later.

Part 8: Common Reference Material

MR-J4 servo amplifier

Rotary servo motor						Graph of overload protection characteristics
HG-KR	HG-MR	HG-SR	HG-UR	HG-RR	HG-JR	
053 13	053 13		72			Characteristics a
23 43 73	23 43 73	51 81 52 102			53 (Note) 73 103	Characteristics b
		121 201 152 202 301 352	152 202	103 153 203	73 (Note) 103 (Note) 153 (Note) 203 (Note) 353	Characteristics c
		421 502 702	352 502	353 503	353 (Note) 601 701M 503 (Note) 703	Characteristics d
					801 12K1 15K1 20K1 25K1 11K1M 15K1M 22K1M 903	Characteristics e
		524 1024			534 (Note) 734 1034	Characteristics b
		1524 2024 3524			734 (Note) 1034 (Note) 1534 (Note) 2034 (Note) 3534	Characteristics c
		5024 7024			3534 (Note) 6014 701M4 5034 (Note) 7034	Characteristics d
					8014 12K14 15K14 20K14 25K14 11K1M4 15K1M4 22K1M4 9034	Characteristics e

Note. The combination is for increasing the maximum torque of the servo motor to 400%.

Servo amplifiers supporting the 400% maximum torque setting (Note)	Servo motor (Note)	Servo amplifiers supporting the 400% maximum torque setting (Note)	Servo motor (Note)
	HG-JR_		HG-JR_
MR-J4-100_(-RJ)	53	MR-J4-100_4(-RJ)	534
MR-J4-200_(-RJ)	73	MR-J4-200_4(-RJ)	734
	103		1034
MR-J4-350_(-RJ)	153	MR-J4-350_4(-RJ)	1534
	203		2034
MR-J4-500_(-RJ)	353	MR-J4-500_4(-RJ)	3534
MR-J4-700_(-RJ)	503	MR-J4-700_4(-RJ)	5034

Note. This is available with servo amplifiers with software version C8 or later. The combination increases the rated torque and the maximum torque.

Part 8: Common Reference Material

The following graphs show overload protection characteristics.

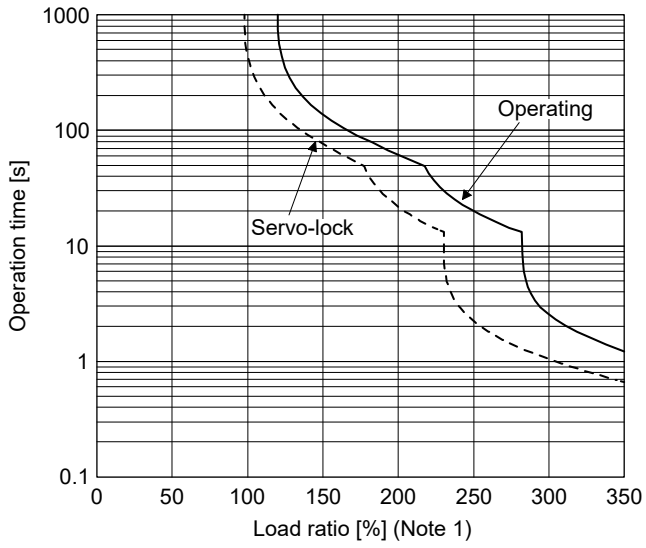

Characteristics a

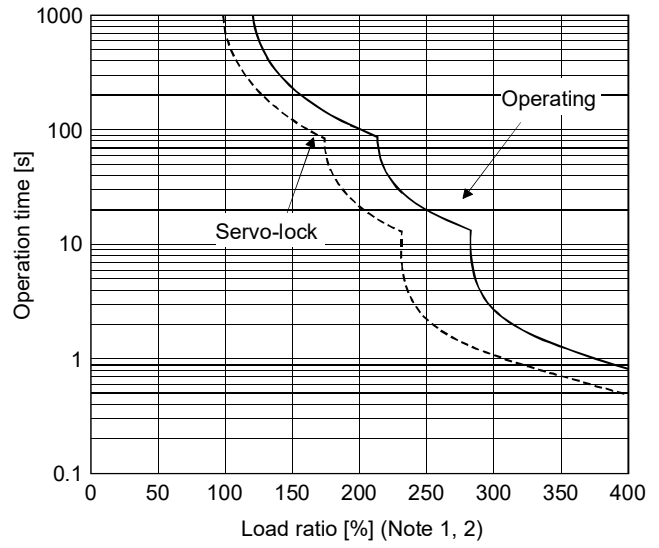

Characteristics b

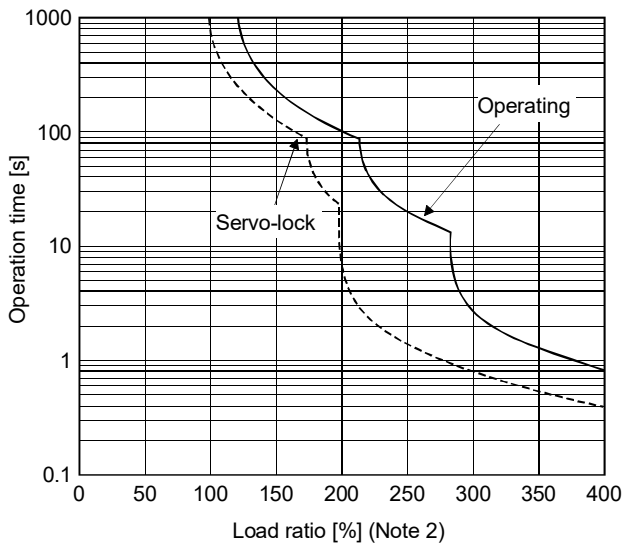

Characteristics c

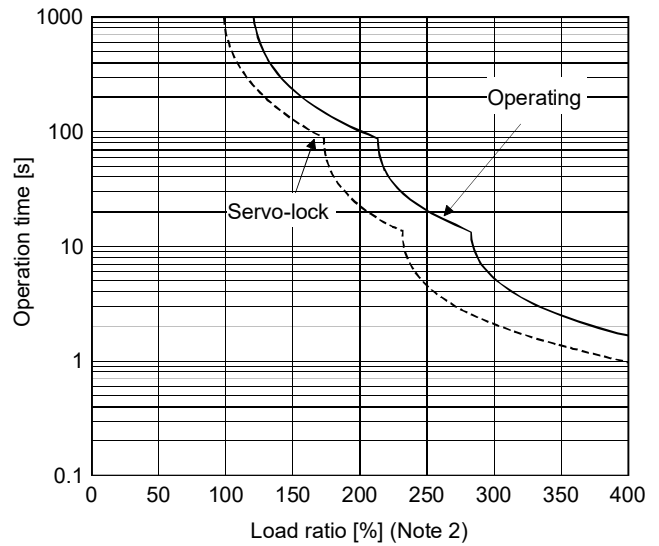

Characteristics d

Part 8: Common Reference Material

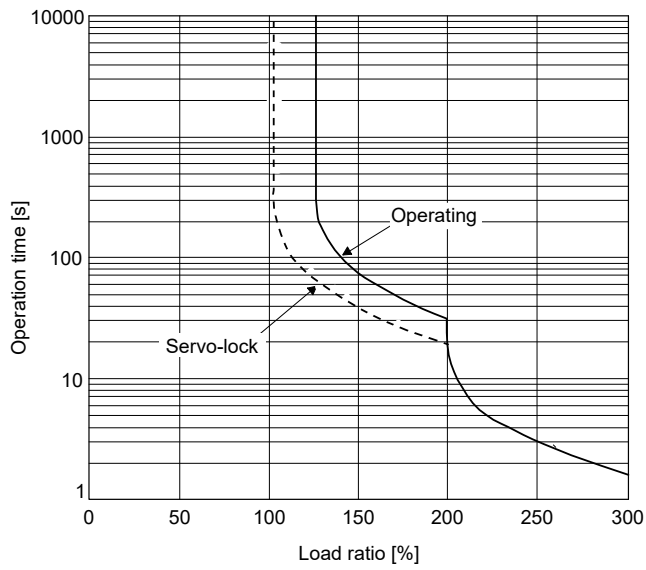

Characteristics e

- Note
1. The operation time at the load ratio of 300% to 350% applies when the maximum torque of HG-KR servo motor and HF-KP servo motor is increased to 350% of rated torque.
 2. The operation time at the load ratio of 300% to 400% applies when the maximum torque of HG-JR servo motor and HF-JP servo motor is increased to 400% of rated torque.

Part 8: Common Reference Material

(2) MR-J4W2-_B servo amplifier/MR-J3W series

The following graphs show overload protection characteristics.

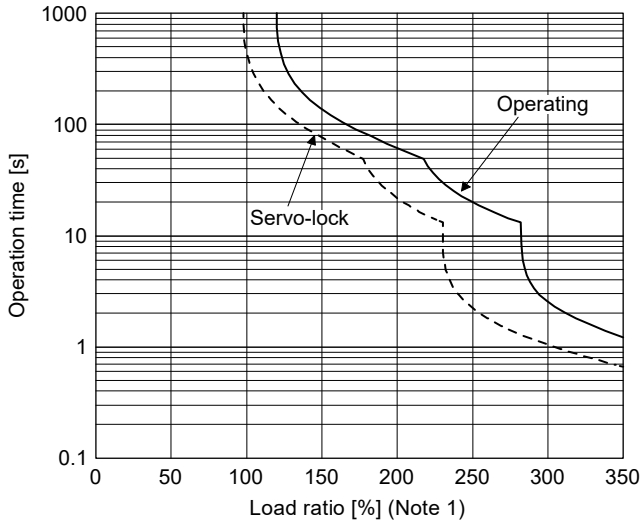

HG-KR053/HG-KR13
HG-MR053/HG-MR13

HF-KP053/HF-KP13
HF-MP053/HF-MP13

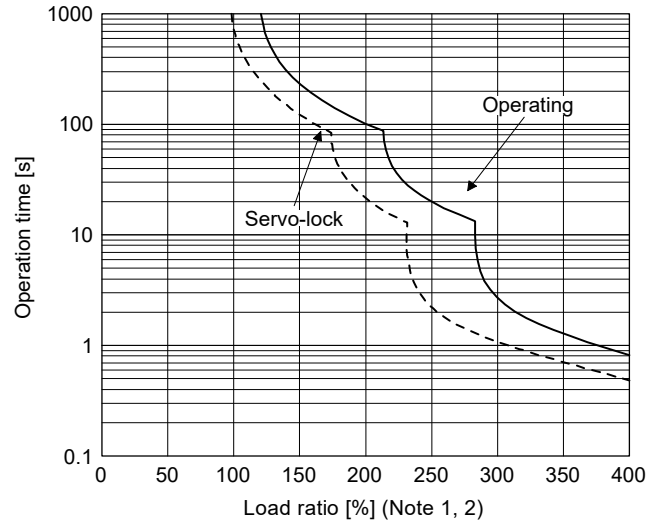

HG-KR23/HG-KR43/HG-KR73
HG-MR23/HG-MR43/HG-MR73
HG-SR51/HG-SR81/HG-SR52/HG-SR102
HG-UR72

HG-JR53/HG-JR73/HG-JR103
HF-KP23/HF-KP43/HF-KP73
HF-MP23/HF-MP43/HF-MP73
HF-SP51/HF-SP81/HF-SP52/HF-SP102
HC-UP72
HC-LP52/HC-LP102
HF-JP53/HF-JP73/HF-JP103

- Note 1. The load ratio ranging from 300% to 350% applies to the HG-KR series servo motor.
Note 2. The operation time at the load ratio of 350% to 400% applies when the maximum torque of HG-JR53 servo motor and HF-JP servo motor is increased to 400% of rated torque.

Part 8: Common Reference Material

(3) MR-J4W2-0303B6/MR-J3W-0303BN6 servo amplifier

The following graphs show overload protection characteristics.

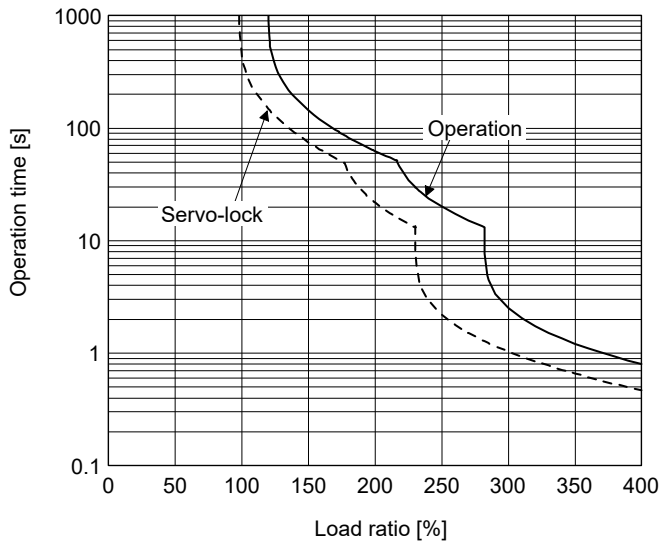

HG-AK0136/HG-AK0236/HG-AK0336

(4) MR-J4-DU_(-RJ)/MR-J3- DU_ drive unit

The following graphs show overload protection characteristics.

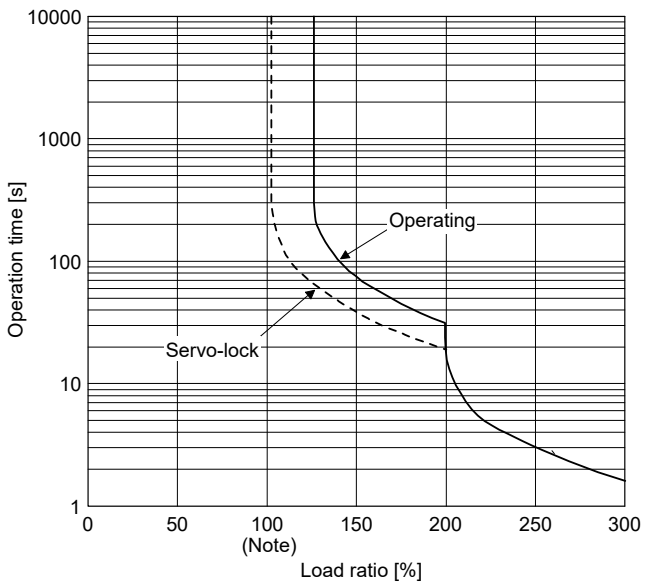

Note. Load ratio 100% indicates the rated output of the drive unit.

Part 8: Common Reference Material

1.4 Comparison of Networks

MR-J4-_B_servo amplifier is connected to controllers, including a servo system controller, on the high-speed synchronous network SSCNET III/H. The servo amplifier directly receives a command from a controller to drive a servo motor.

SSCNET III/H allows higher-speed communication of 150 Mbps for both upstream and downstream traffic to be achieved with high noise resistance enabled by adoption of the SSCNET III optical cables. Large amounts of data are exchanged in real-time between the controller and the servo amplifier. Servo monitor information is stored in the upper information system and is used for control.

1.4.1 Comparison of servo system network specifications

Item	MR-J3/MR-J3W series	
	SSCNET III	
Communication media	Optical fiber cable	
Communication speed	50 Mbps	
Transmission distance	[Standard cord inside cabinet/ standard cable outside cabinet] Maximum distance between stations: 20 m	
	[Long distance cable] Maximum distance between stations: 50 m	

→

MR-J4 series (Note)	
SSCNET III	SSCNET III/H
Optical fiber cable	
50 Mbps	150 Mbps
[Standard cord inside cabinet/ standard cable outside cabinet] Maximum distance between stations: 20 m	
[Long distance cable] Maximum distance between stations: 50 m	[Long distance cable] Maximum distance between stations: 100 m

Note. When you connect an amplifier with SSCNET III/H communication for the first controller communication with the factory setting, the operation mode will be fixed to "J4 mode". For SSCNET III communication, the operation mode will be fixed to "J3 compatibility mode". To return to the factory setting or to select an arbitrary mode, change the setting with the application "MR Mode Change".

The application "MR Mode Change" is available with MR Configurator2 Version 1.12N and later. When a version older than 1.12N is used, download an update version from the MITSUBISHI ELECTRIC FA Global Website.

(1) Explanation of SSCNET III/H cable models

Function	Name	J4 series		MR-J3/MR-J3W series
		J4 mode	J3 compatibility mode	
SSCNET III/H communication or SSCNET III communication	Communication baud rate	150 Mbps	50 Mbps	50 Mbps
	Maximum distance between stations	100 m	50 m	50 m

Note. For cable of 30 m or shorter, contact your local sales office.

Contact Mitsubishi Electric System & Service about ultra-high flex-life cables and long distance cables longer than 50 m.

Part 8: Common Reference Material

(2) SSCNET III/H cable specifications

POINT
●SSCNET III cables can be used as they are.

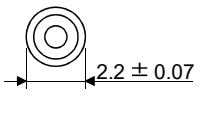
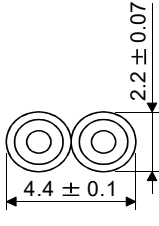
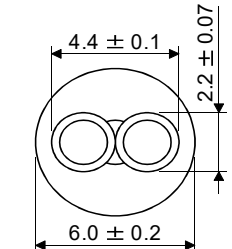
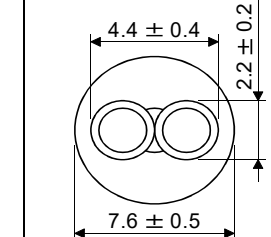
		Description			
SSCNET III/H cable model		MR-J3BUS_M		MR-J3BUS_M-A	MR-J3BUS_M-B
SSCNET III/H cable length		0.15 m	0.3 m to 3 m	5 m to 20 m	30 m to 50 m
Optical cable (cord)	Minimum bend radius	25 mm		Enforced covering cable: 50 mm Cord: 25 mm	Enforced covering cable: 50 mm Cord: 30 mm
	Tension strength	70 N	140 N	420 N (Enforced covering cable)	980 N (Enforced covering cable)
	Temperature range for use (Note)	-40 °C to 85 °C			-20 °C to 70 °C
	Atmosphere	Indoors (not exposed to direct sunlight), no solvent or oil.			
	Appearance [mm]				

Note. This temperature range for use is the value for optical cable (cord) only. Temperature condition for the connector is the same as that for servo amplifier.

Part 8: Common Reference Material

2. SERVO AMPLIFIER DIMENSIONS/ATTACHMENT DIFFERENCES

2.1 MR-J3 series => MR-J4 series Comparison Table of Servo Amplifier Dimensions/Installation Differences

POINT
● Dimensions with differences are shown with shading.
● Only the dimensions of servo amplifiers are compared. For the dimensions of MR-J3-D01 and MR-D01, refer to section 2.1.3.

2.1.1 1-axis servo amplifier 200 V/100 V class (22 kW or less)

(1) Comparison of Dimensions

The following table shows comparison of the MR-J3 series and MR-J4 series dimensions. Dimensions of servo amplifiers of 3.5 kW or less, 7 kW, and 22 kW are the same and have compatibility in mounting. Note that the width and horizontal mounting screw pitch have been changed for servo amplifiers of 5 kW. For servo amplifiers of 11 kW and 15 kW, note that the width, vertical/horizontal mounting screw pitch, and screw size have been changed.

The dimensions are different between MR-J3-_T_ and MR-J4-_GF_. Refer to Table 2 for details.

Table. 1 Comparison of dimensions (comparison between the same capacity types) [Unit: mm]

Model MR-J3 series	Model MR-J4 series (Note 2)	Height		Width (Note 1)		Depth		Mounting screw pitch	
		MR-J3	MR-J4	MR-J3	MR-J4	MR-J3	MR-J4	MR-J3	MR-J4
MR-J3-10_(1)	MR-J4-10_(1) (-RJ)	168	168	40 (60)	40 (60)	135	135	156 (Vertical) (2 screws)	156 (Vertical) (2 screws)
MR-J3-20_(1)	MR-J4-20_(1) (-RJ)								
MR-J3-40_(1)	MR-J4-40_(1) (-RJ)					170	170		
MR-J3-60_	MR-J4-60_(-RJ)								
MR-J3-70_	MR-J4-70_(-RJ)			60 (80)	60 (80)	185	185	156 (Vertical)/ 42 (Horizontal) (3 screws)	156 (Vertical)/ 42 (Horizontal) (3 screws)
MR-J3-100_	MR-J4-100_(-RJ)			90 (105)	90 (105)	195	195	156 (Vertical)/ 78 (Horizontal) (3 screws)	156 (Vertical)/ 78 (Horizontal) (3 screws)
MR-J3-200_(N)(-RT)	MR-J4-200_(-RJ)			MR-J3-350_	MR-J4-350_(-RJ)				
MR-J3-500_	MR-J4-500_(-RJ)	250	250	130 (140)	105 (115)	200	200	235 (Vertical)/ 118 (Horizontal) (4 screws)	235 (Vertical)/ 93 (Horizontal) (4 screws)
MR-J3-700_	MR-J4-700_(-RJ)	300	300	172 (182)	172 (182)			285 (Vertical)/ 160 (Horizontal) (4 screws)	285 (Vertical)/ 160 (Horizontal) (4 screws)
MR-J3-11K_(-LR)	MR-J4-11K_(-RJ)	400	400	260 (260)	220 (220)	260	260	376 (Vertical)/ 236 (Horizontal) (4 screws)	380 (Vertical)/ 196 (Horizontal) (4 screws)
MR-J3-15K_(-LR)	MR-J4-15K_(-RJ)				260 (260)				
MR-J3-22K_	MR-J4-22K_(-RJ)				260 (260)				376 (Vertical)/ 236 (Horizontal) (4 screws)

Note 1. The values in the parentheses show the dimensions for when MR-J3-D01 or MR-D01 has been mounted.

2. Refer to the following table for MR-J4-10GF(1)/MR-J4-20GF(1)/MR-J4-40GF(1)/MR-J4-60GF.

Part 8: Common Reference Material

Table. 2 Comparison of dimensions (comparison between the same capacity types) [Unit: mm]

Model MR-J3 series	Model MR-J4 series	Height		Width		Depth		Mounting screw pitch	
		MR-J3	MR-J4	MR-J3	MR-J4	MR-J3	MR-J4	MR-J3	MR-J4
MR-J3-10T(1)	MR-J4-10GF(1)	168	168	40	50	135	155	156 (Vertical) (2 screws)	156 (Vertical) (2 screws)
MR-J3-20T(1)	MR-J4-20GF(1)								
MR-J3-40T(1)	MR-J4-40GF(1)					170			
MR-J3-60T	MR-J4-60GF								

When replacing two or more units of MR-J3-_T_ with MR-J4-_GF_, pay attention to the distance between the units during installation. For details, refer to section 2.1 of "MR-J4-_GF_(-RJ) Servo Amplifier Instruction Manual (Motion Mode)".

Part 8: Common Reference Material

(2) Comparison of dimensions

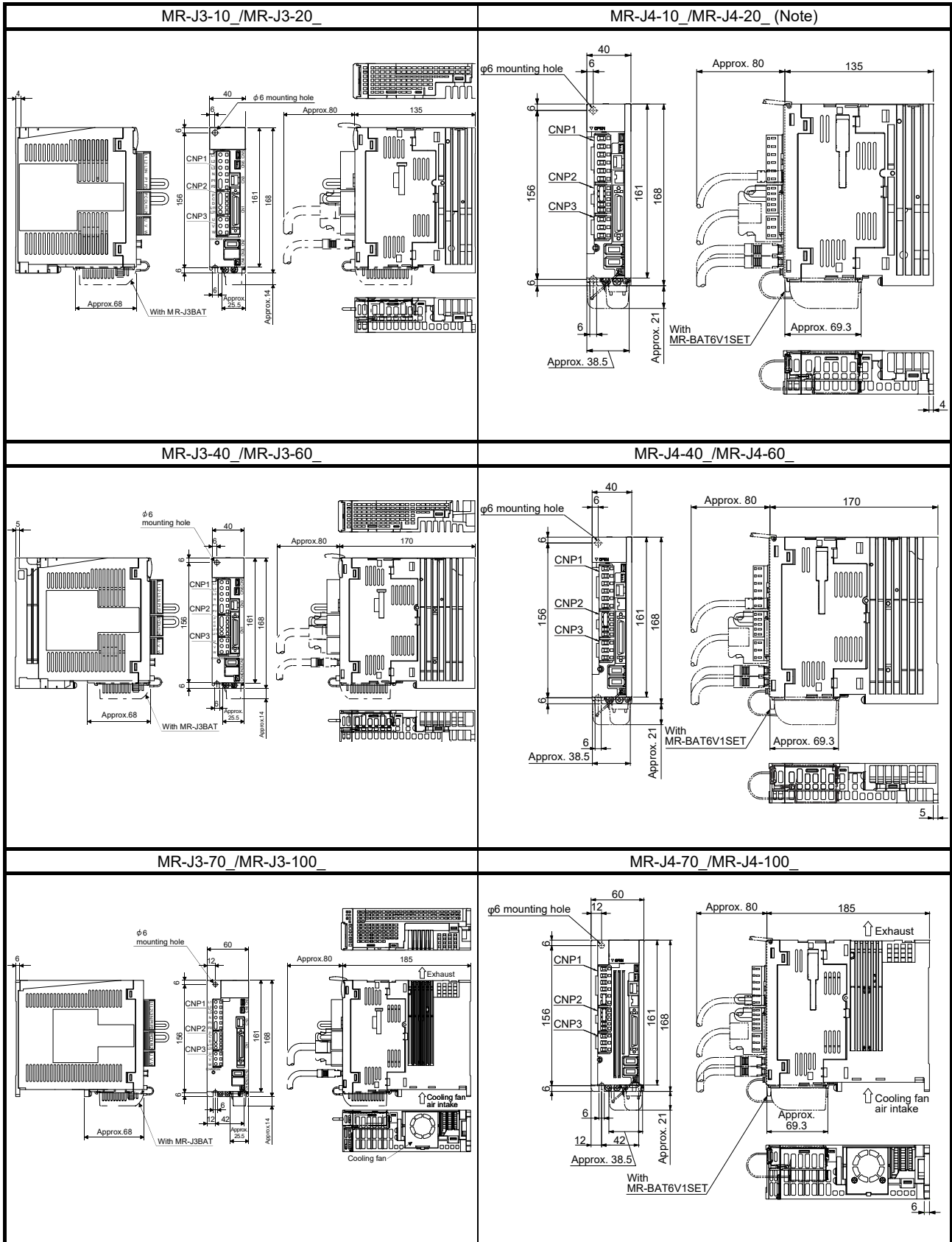

Note. Refer to this section (3) for MR-J4-10GF(1)/MR-J4-20GF(1)/MR-J4-40GF(1)/MR-J4-60GF.

Part 8: Common Reference Material

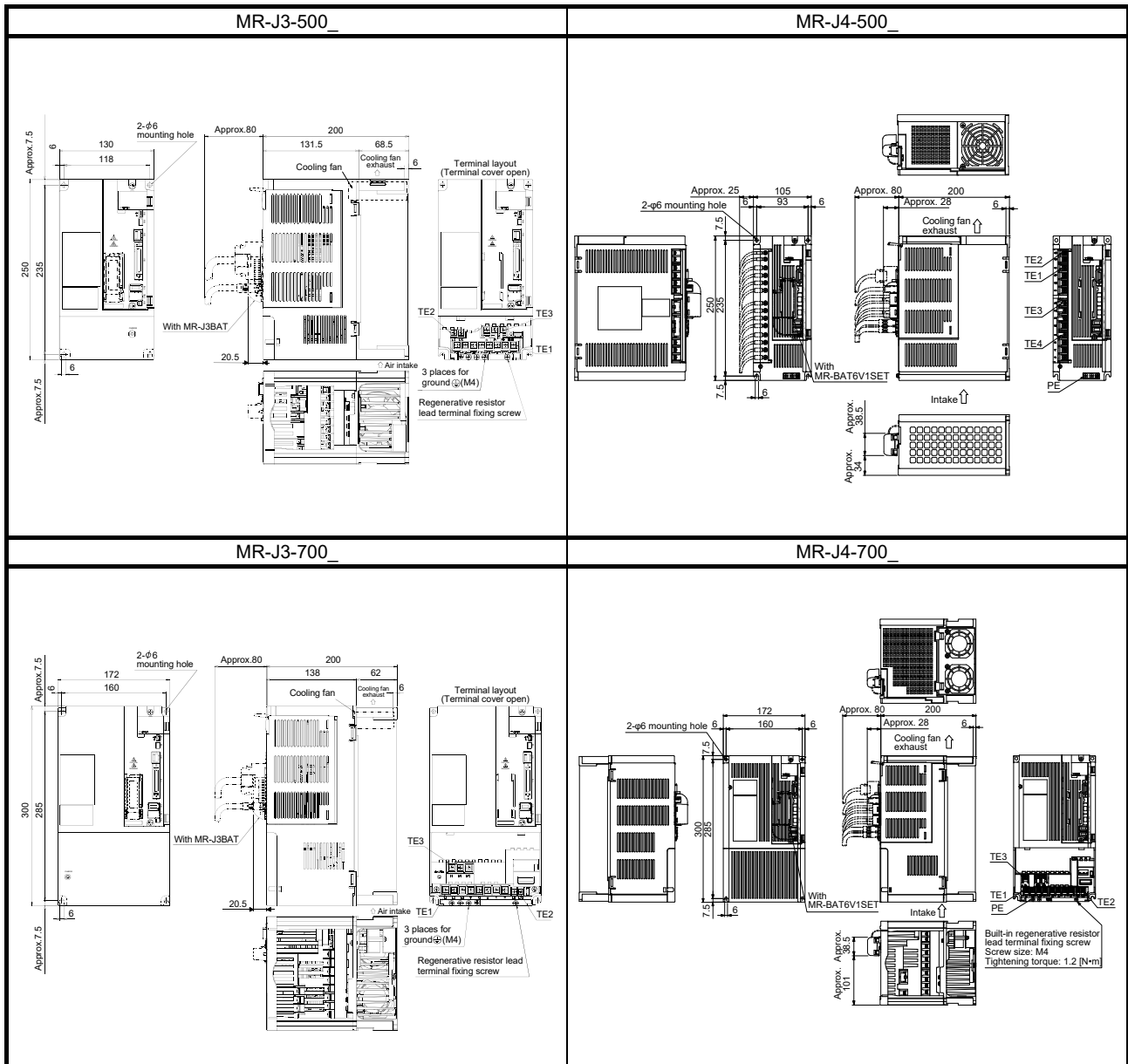

Part 8: Common Reference Material

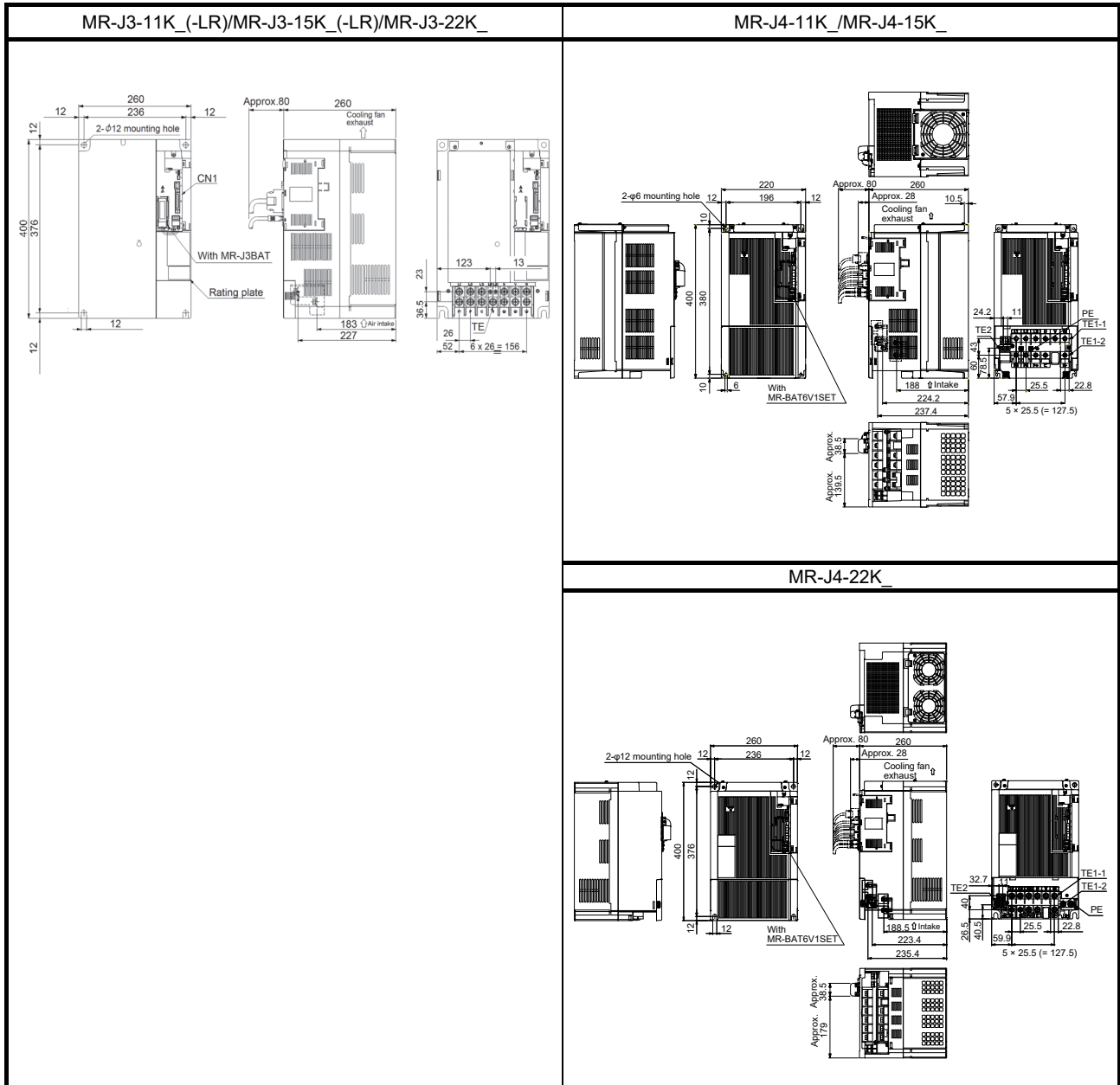

Part 8: Common Reference Material

(3) Comparison of dimensions (MR-J4-10GF(1)/MR-J4-20GF(1)/MR-J4-40GF(1)/MR-J4-60GF)

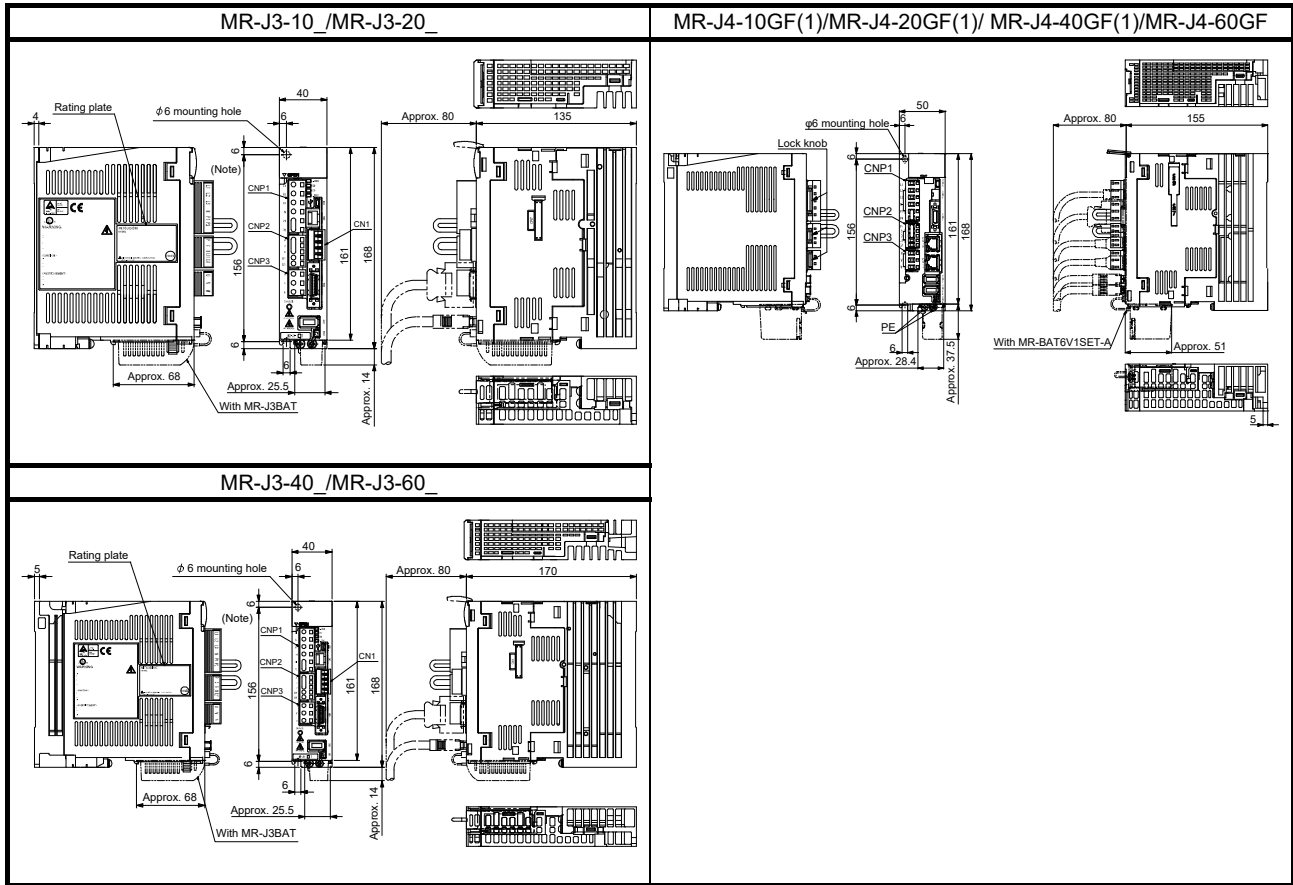

Part 8: Common Reference Material

2.1.2 1-axis servo amplifier 400 V class (22 kW or less)

(1) Comparison of dimensions

The following table shows comparison of the MR-J3 series and MR-J4 series dimensions. Dimensions of servo amplifiers of 2 kW or less, 5 kW, 7 kW, and 22 kW are the same and have compatibility in mounting. Note that the width and horizontal mounting screw pitch have been changed for servo amplifiers of 3.5 kW. For servo amplifiers of 11 kW and 15 kW, note that the width, vertical/horizontal mounting screw pitch, and screw size have been changed.

Comparison of dimensions (comparison between the same capacity types) [Unit: mm]

Model MR-J3 series	Model MR-J4 series	Height		Width (Note)		Depth		Mounting screw pitch		
		MR-J3	MR-J4	MR-J3	MR-J4	MR-J3	MR-J4	MR-J3	MR-J4	
MR-J3-60_4	MR-J4-60_4(-RJ)	168	168	60	60	195	195	156 (Vertical)/ 42 (Horizontal)	156 (Vertical)/ 42 (Horizontal)	
MR-J3-100_4	MR-J4-100_4(-RJ)			(80)	(80)			(3 screws)	(3 screws)	
MR-J3-200_4	MR-J4-200_4(-RJ)			90 (105)	90 (105)			(3 screws)	156 (Vertical)/ 78 (Horizontal) (3 screws)	156 (Vertical)/ 78 (Horizontal) (3 screws)
MR-J3-350_4	MR-J4-350_4(-RJ)	250	250	130	105	200	200	235 (Vertical)/ 118 (Horizontal) (4 screws)	235 (Vertical)/ 93 (Horizontal)	
MR-J3-500_4	MR-J4-500_4(-RJ)			(140)	(115)				(4 screws)	235 (Vertical)/ 118 (Horizontal) (4 screws)
MR-J3-700_4	MR-J4-700_4(-RJ)			172 (182)	172 (182)				(4 screws)	285 (Vertical)/ 160 (Horizontal) (4 screws)
MR-J3-11K_4(-LR)	MR-J4-11K_4(-RJ)	400	400	260 (260)	220	260	260	376 (Vertical)/ 236 (Horizontal) (4 screws)	380 (Vertical)/ 196 (Horizontal)	
MR-J3-15K_4(-LR)	MR-J4-15K_4(-RJ)				(220)				(4 screws)	
MR-J3-22K_4	MR-J4-22K_4(-RJ)				260 (260)				(4 screws)	376 (Vertical)/ 236 (Horizontal) (4 screws)

Note. The values in the parentheses show the dimensions for when MR-J3-D01 or MR-D01 has been mounted.

Part 8: Common Reference Material

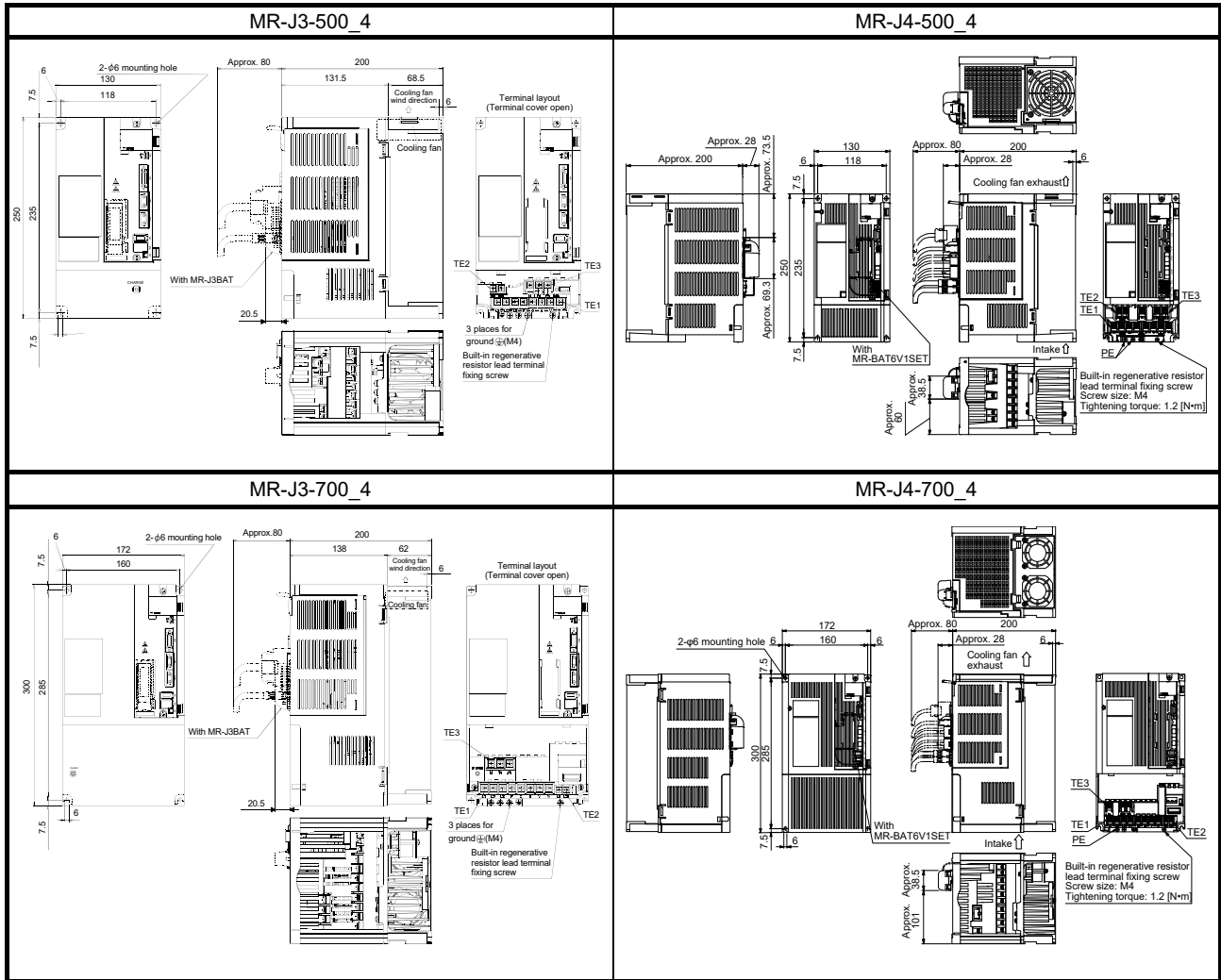

Part 8: Common Reference Material

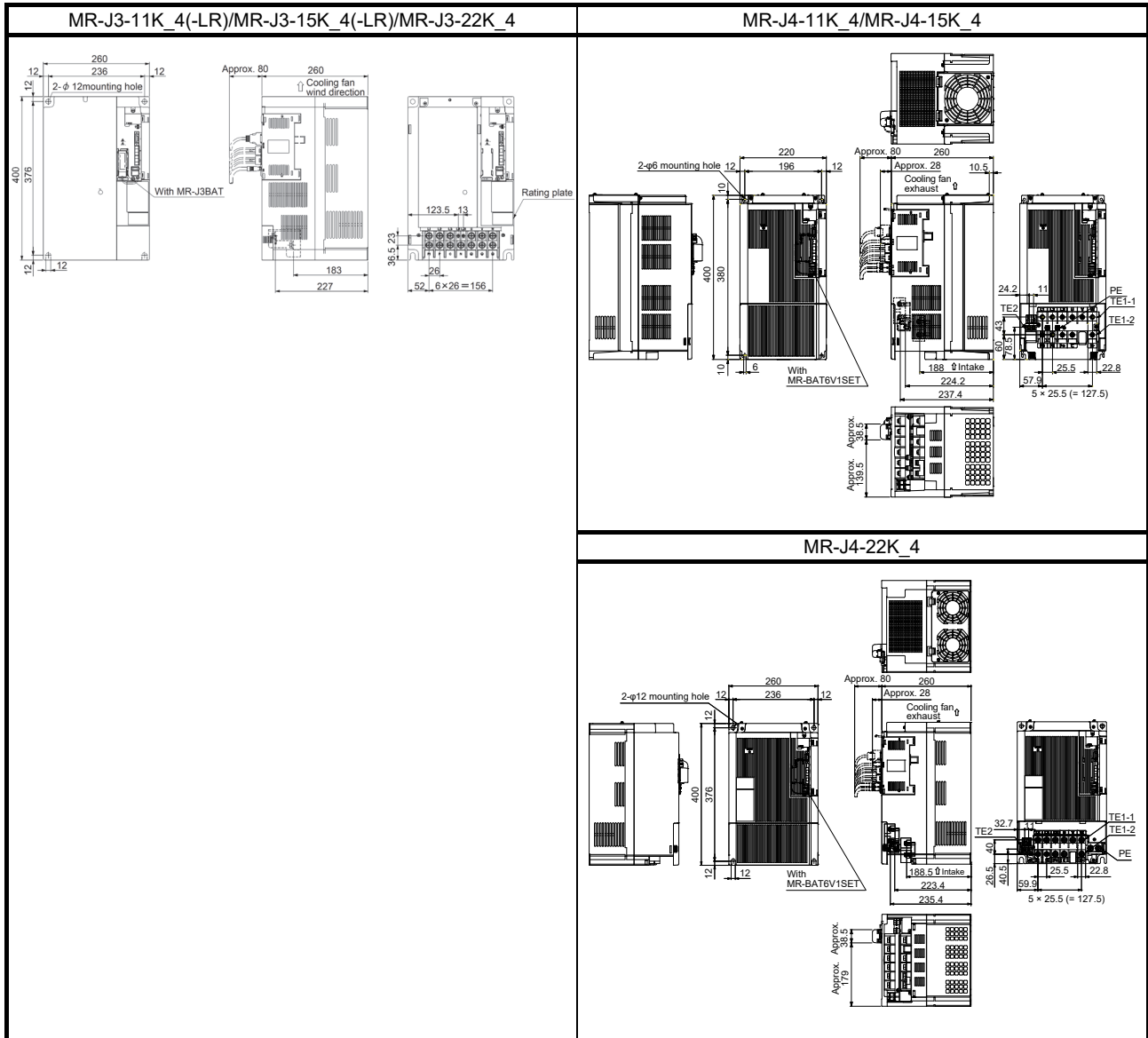

Part 8: Common Reference Material

2.1.3 MR-J3-D01/MR-D01

[Unit: mm]

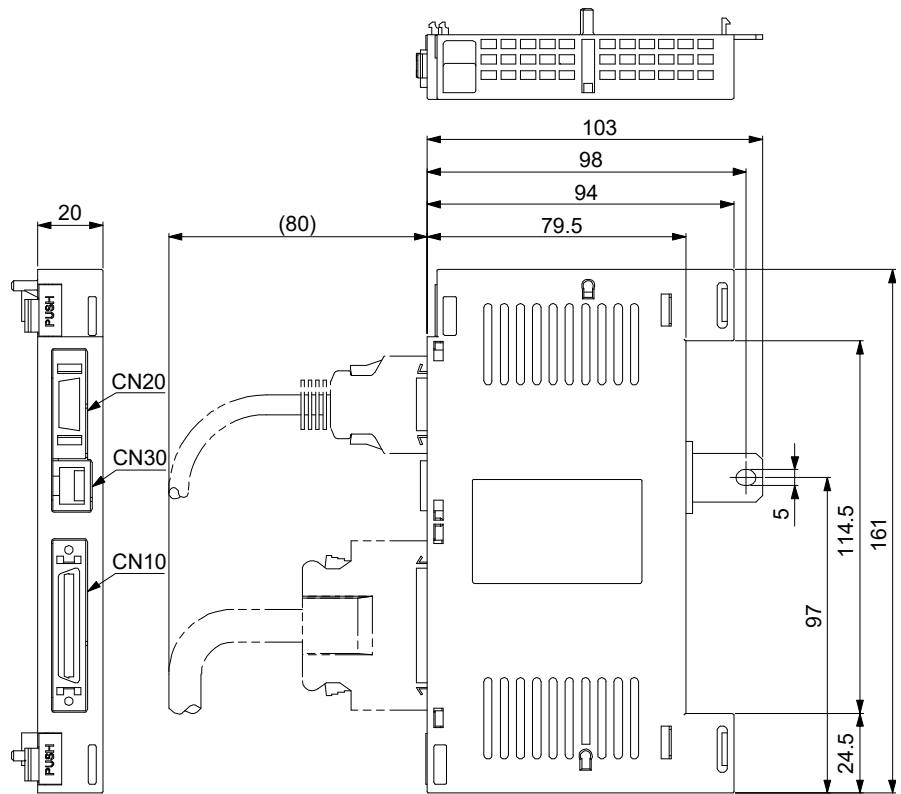

When an MR-D01 extension IO unit is connected to a servo amplifier

100 V/200 V 0.1 kW to 3.5 kW
400 V 0.6 kW to 2 kW
Servo amplifier

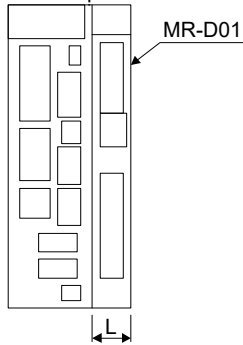

200 V 5 kW/7 kW
400 V 3.5 kW to 7 kW
Servo amplifier

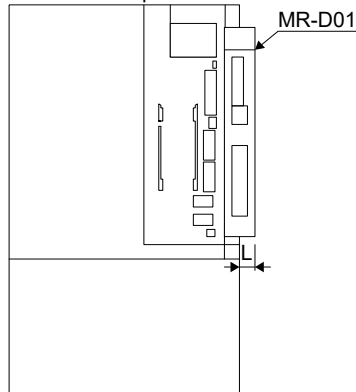

Servo amplifier	L [mm]
MR-J4-10A1-RJ to MR-J4-40A1-RJ MR-J4-10A-RJ to MR-J4-100A-RJ MR-J4-60A4-RJ to MR-J4-100A4-RJ	20
MR-J4-200A-RJ/MR-J4-350A-RJ MR-J4-200A4-RJ	15
MR-J4-500A-RJ/MR-J4-700A-RJ MR-J4-350A4-RJ to MR-J4-700A4-RJ	10
MR-J4-11KA-RJ to MR-J4-22KA-RJ MR-J4-11KA4-RJ to MR-J4-22KA4-RJ	0

Part 8: Common Reference Material

2.1.4 Drive unit and converter unit 200 V class (30 kW or more)

(1) Comparison of Dimensions

The following table shows comparison of the MR-J3 series and MR-J4 series dimensions. The two are the same in height, width, mounting screw pitch, and screw size, and therefore compatible in mounting. When the servo amplifier is mounted so that the heat sink is inside the cabinet, the depth vary.

Comparison of dimensions (comparison between the same capacity types) [Unit: mm]

Model MR-J3 series	Model MR-J4 series	Height		Width		Depth		Mounting screw pitch	
		MR-J3	MR-J4	MR-J3	MR-J4	MR-J3	MR-J4	MR-J3	MR-J4
MR-J3-DU30K_	MR-J4-DU30K_	380	380	300	300	200	200	360 (Vertical)/ 260 (Horizontal) (4 screws)	360 (Vertical)/ 260 (Horizontal) (4 screws)
MR-J3-DU37K_	MR-J4-DU37K_					(328)	(300)		
MR-J3-CR55K	MR-CR55K	380	380	300	300	200	200	360 (Vertical)/ 260 (Horizontal) (4 screws)	360 (Vertical)/ 260 (Horizontal) (4 screws)
						(328)	(300)		
						(Note)	(Note)		

Note. The values in the parentheses are applied to when a heat sink is placed in a cabinet.

(2) Comparison dimensions

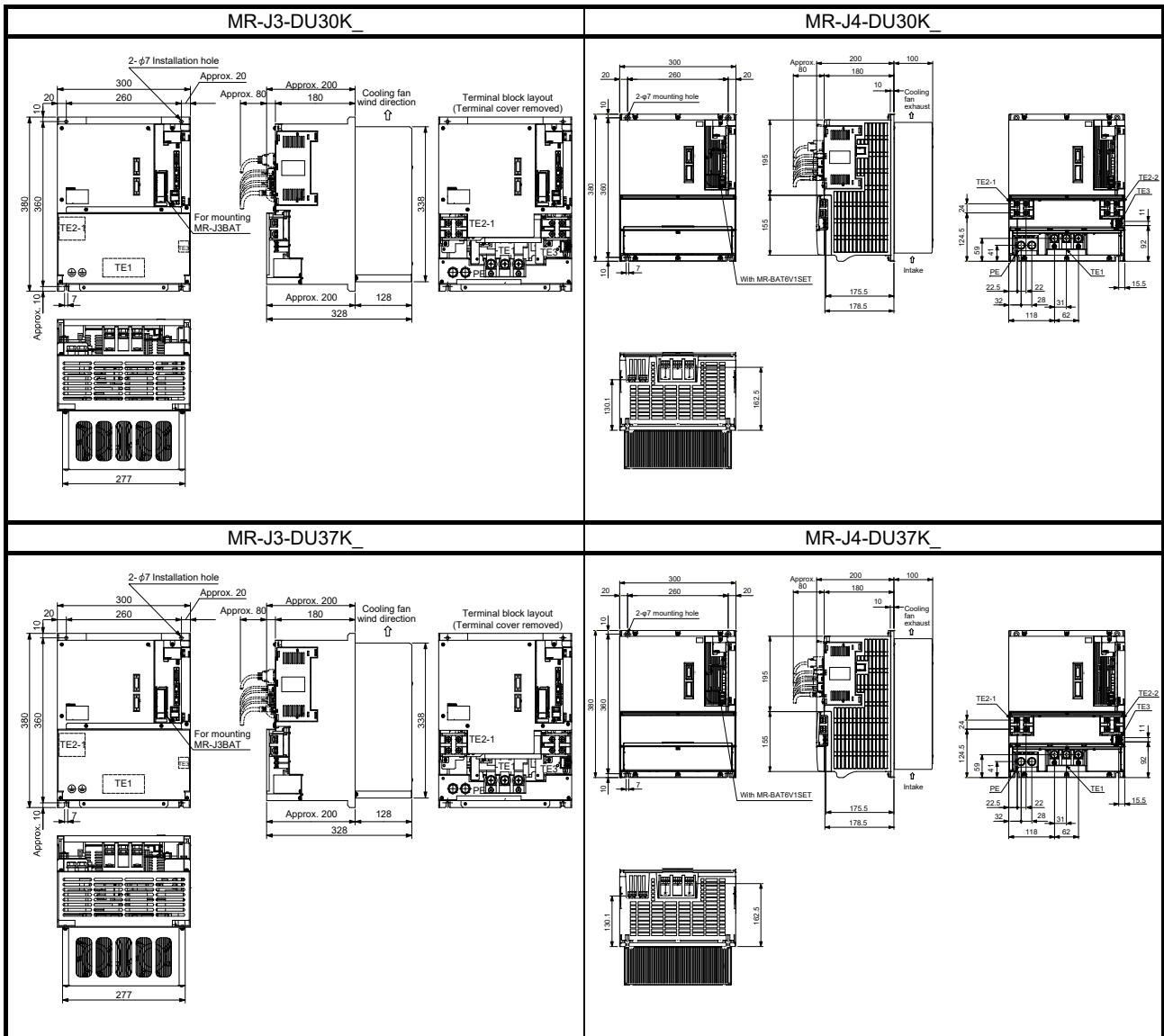

Part 8: Common Reference Material

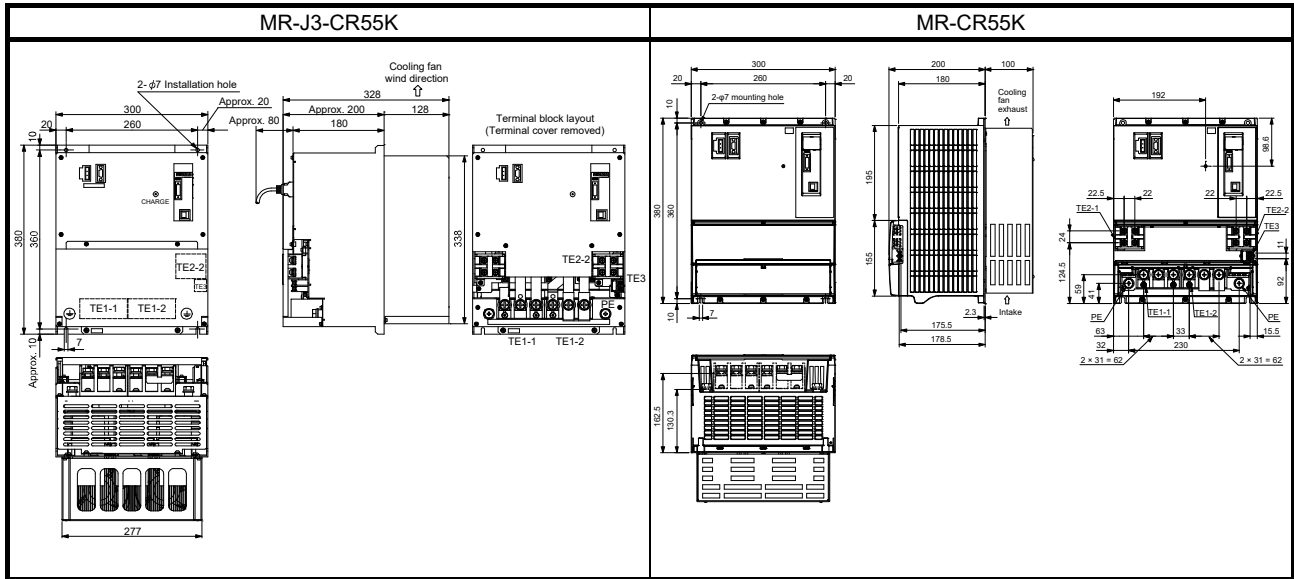

Part 8: Common Reference Material

2.1.5 Drive unit and converter unit 400 V class (30 kW or more)

(1) Comparison of Dimensions

The following table shows comparison of the MR-J3 series and MR-J4 series dimensions. The two are the same in height, width, mounting screw pitch, and screw size, and therefore compatible in mounting. When the servo amplifier is mounted so that the heat sink is inside the cabinet, the depth vary.

Comparison of dimensions (comparison between the same capacity types) [Unit: mm]

Model MR-J3 series	Model MR-J4 series	Height		Width		Depth		Mounting screw pitch	
		MR-J3	MR-J4	MR-J3	MR-J4	MR-J3	MR-J4	MR-J3	MR-J4
MR-J3-DU30K_4	MR-J4-DU30K_4	380	380	240	240	200	200	360 (Vertical)/ 120 (Horizontal) (4 screws)	360 (Vertical)/ 120 (Horizontal) (4 screws)
MR-J3-DU37K_4	MR-J4-DU37K_4					(328) (Note)	(300) (Note)		
MR-J3-DU45K_4	MR-J4-DU45K_4	380	380	300	300	200	200	360 (Vertical)/ 260 (Horizontal) (4 screws)	360 (Vertical)/ 260 (Horizontal) (4 screws)
MR-J3-DU55K_4	MR-J4-DU55K_4					(328) (Note)	(300) (Note)		
MR-J3-CR55K4	MR-CR55K4	380	380	300	300	200 (328) (Note)	200 (300) (Note)	360 (Vertical)/ 260 (Horizontal) (4 screws)	360 (Vertical)/ 260 (Horizontal) (4 screws)

Note. The values in the parentheses are applied to when a heat sink is placed in a cabinet.

(2) Comparison dimensions

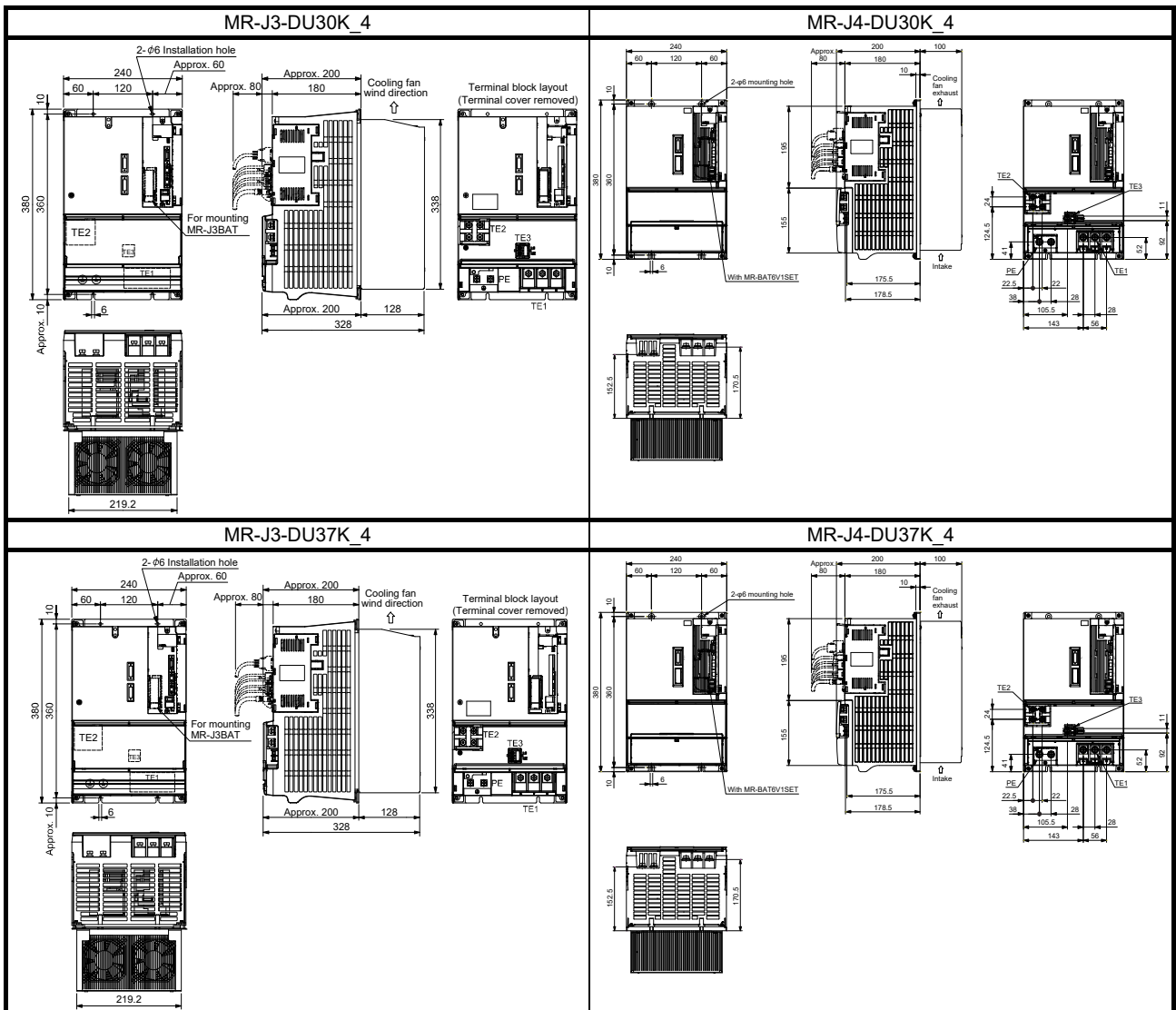

Part 8: Common Reference Material

2.1.6 Multi-axis servo amplifier

(1) Comparison of Dimensions

The following table shows comparison of the MR-J3 series and MR-J4 series dimensions. Note that the number of the mounting screws for 200 W/400 W has been changed. The width, the mounting screw pitch in vertical directions, and the number of the mounting screws for 750 W/1 kW have also been changed.

Comparison of dimensions (comparison between the same capacity types) [Unit: mm]

Model MR-J3 series	Model MR-J4 series	Height		Width		Depth		Mounting screw pitch	
		MR-J3	MR-J4	MR-J3	MR-J4	MR-J3	MR-J4	MR-J3	MR-J4
MR-J3W-22B	MR-J4W2-22B	168	168	60	60	195	195	156 (Vertical)/ 48 (Horizontal) (4 screws)	156 (Vertical) (2 screws)
MR-J3W-44B	MR-J4W2-44B								
MR-J3W-77B	MR-J4W2-77B	168	168	100	85 (Note)	195	195	156 (Vertical)/ 88 (Horizontal) (4 screws)	156 (Vertical)/ 73 (Horizontal) (3 screws)
MR-J3W-1010B	MR-J4W2-1010B								
MR-J3W-0303BN6	MR-J4W2-0303B6	168	168	30	30	100	100	156 (Vertical) (2 screws)	156 (Vertical) (2 screws)

Note. Some have been changed in width.

(2) Comparison dimensions

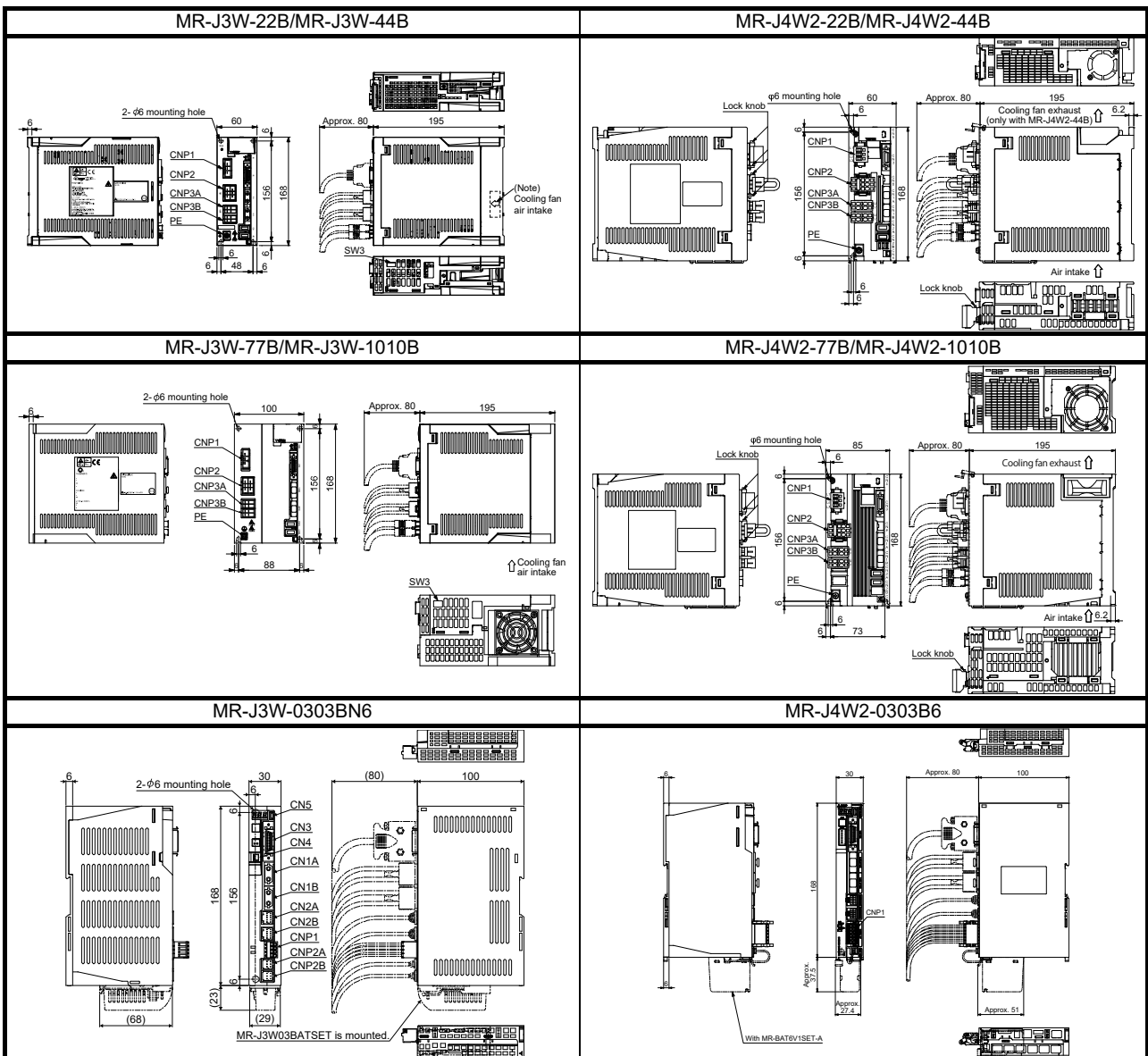

Part 8: Common Reference Material

2.2 Parameter conversion

2.2.1 Operation procedure of parameter conversion

The parameter converter function of MR Configurator2 converts the servo parameters of MR-J3-A /MR-J3-T to the servo parameters of MR-J4-A /MR-J4-A -RJ/MR-J4-GF .

The version of MR Configurator2 is as follows depending on the model used.

- When replacing MR-J3-A to MR-J4-A : 1.12N or later
- When replacing MR-J3-T to MR-J4-A -RJ: 1.72A or later
- When replacing MR-J3-T to MR-J4-GF : 1.120A or later

POINT
<p>● Only the parameters common to replacing MR-J3-<u>A</u> to MR-J4-<u>A</u>, replacing MR-J3-<u>T</u> (DIO/serial communication) to MR-J4-<u>A</u> -RJ, and replacing MR-J3-<u>T</u> (CC-Link communication) to MR-J4-<u>GF</u> are applicable.</p> <p>The initial value of MR-J4-<u>A</u> (-RJ) is set for additional parameters of MR-J4-<u>A</u> (-RJ).</p> <p>The initial value of MR-J4-<u>GF</u> is set for additional parameters of MR-J4-<u>GF</u>.</p>

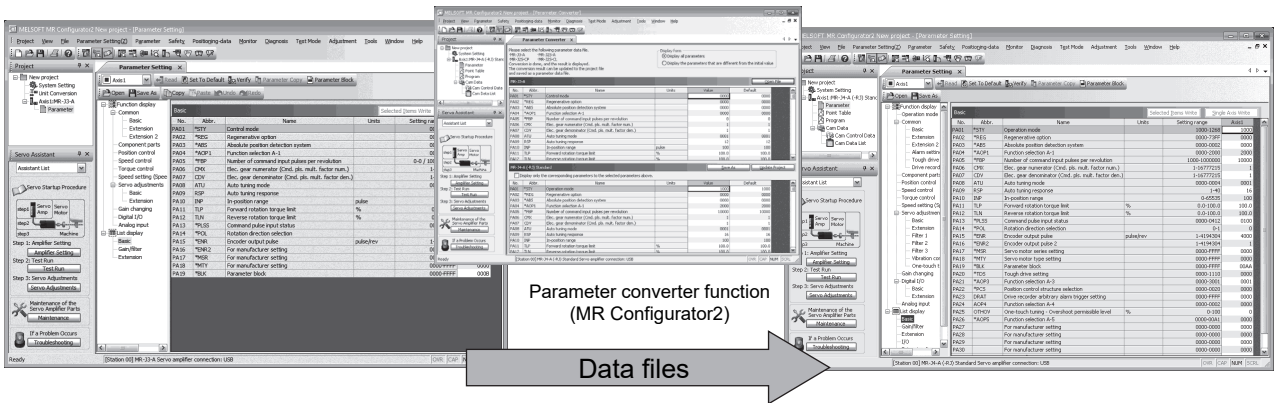

MR Configurator2

MR Configurator2

Change MR-J3-A /MR-J3-T to MR-J4-A /MR-J4-A -RJ/MR-J4-GF

Part 8: Common Reference Material

2.2.2 MR-J3-_A_/MR-J3-_T_ parameter diversion procedure

POINT

- | |
|---|
| <ul style="list-style-type: none">● Parameter conversion: Set the parameter block within the readable range to read changes from the initial value. |
|---|

- Parameter reading from the servo amplifier MR- J3- _A_/MR-J3- _T_

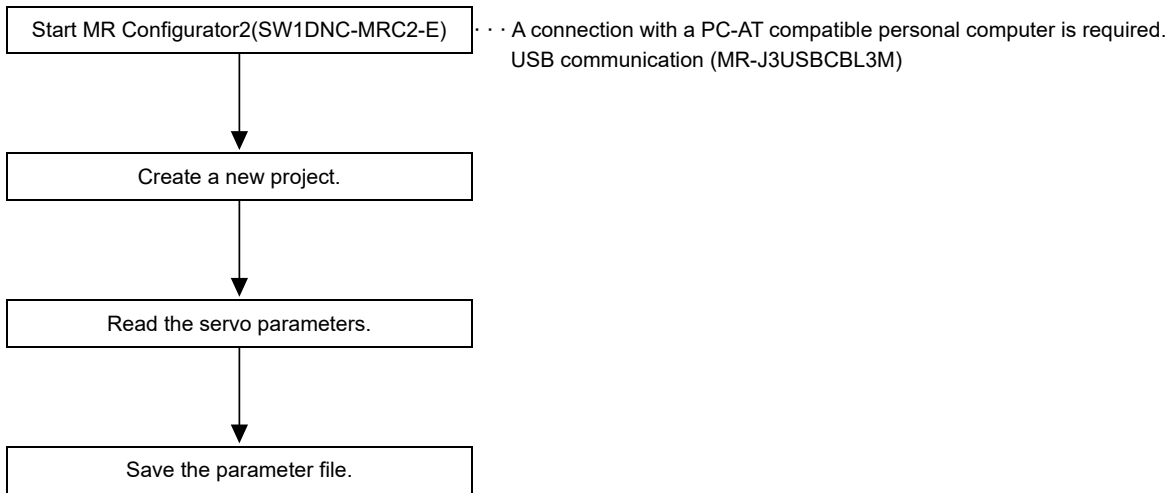

- Converting the parameters of MR-J3-_A_/MR-J3-_T_ and writing them to the MR-J4-_A_(-RJ)/MR-J4-_GF_ servo amplifier

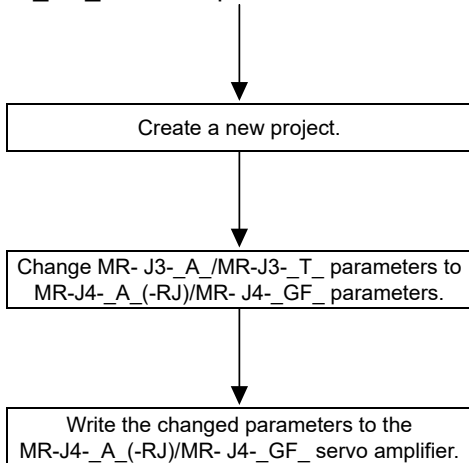

Part 8: Common Reference Material

2.2.3 Parameter reading from the servo amplifier MR- J3-_A_/MR-J3-_T_

- (1) Start MR Configurator2 (SW1DNC-MRC2-E).

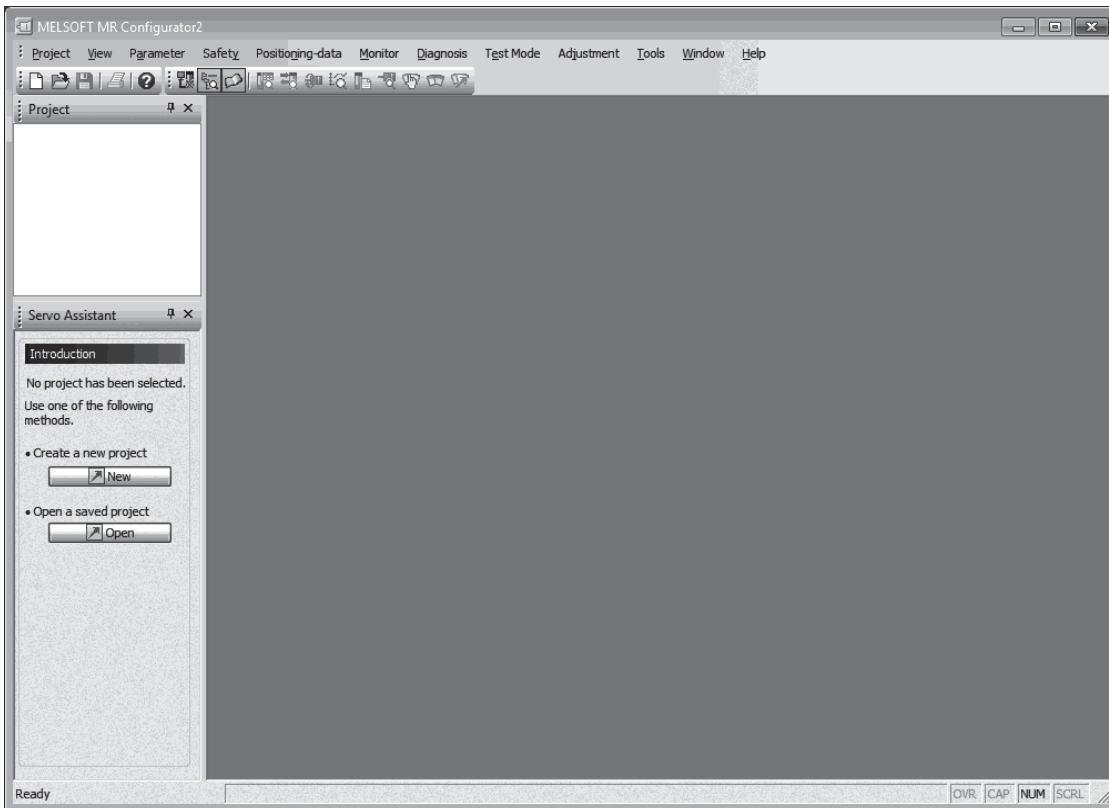

- (2) Create a new project.

Select [Project] - [New] from the menu to display the New Project dialog box. Select "MR-J3-A" or "MR-J3-T" for Model.

The setting of "Station" must be the same as that of the servo amplifier. Set the same value as that of the parameter: [Pr. PC20]. The following figure shows an example of when "MR-J3-A" is selected for Model.

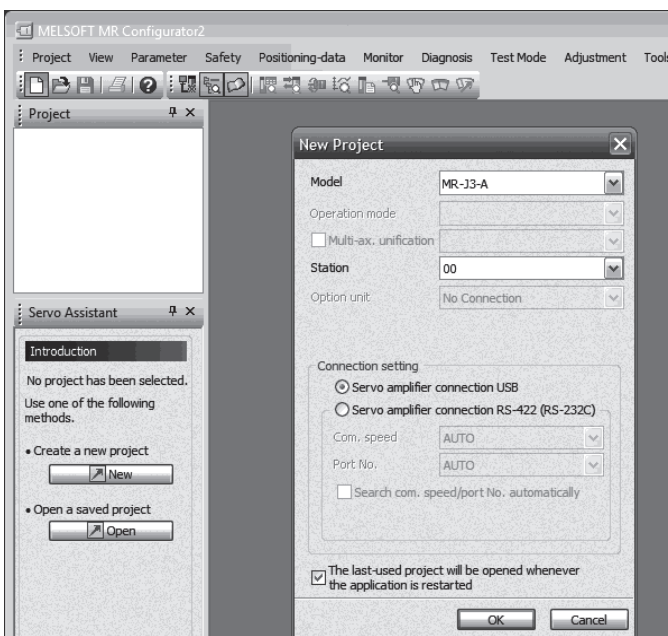

Part 8: Common Reference Material

(3) Read the servo parameters.

Click [Parameters] in the menu to display the parameter list screen.

Connect the MR-J3- A_/MR-J3- T_ servo amplifier to a personal computer and click the [Read] button.

The following figure shows an example of when "MR-J3-A" is selected for Model.

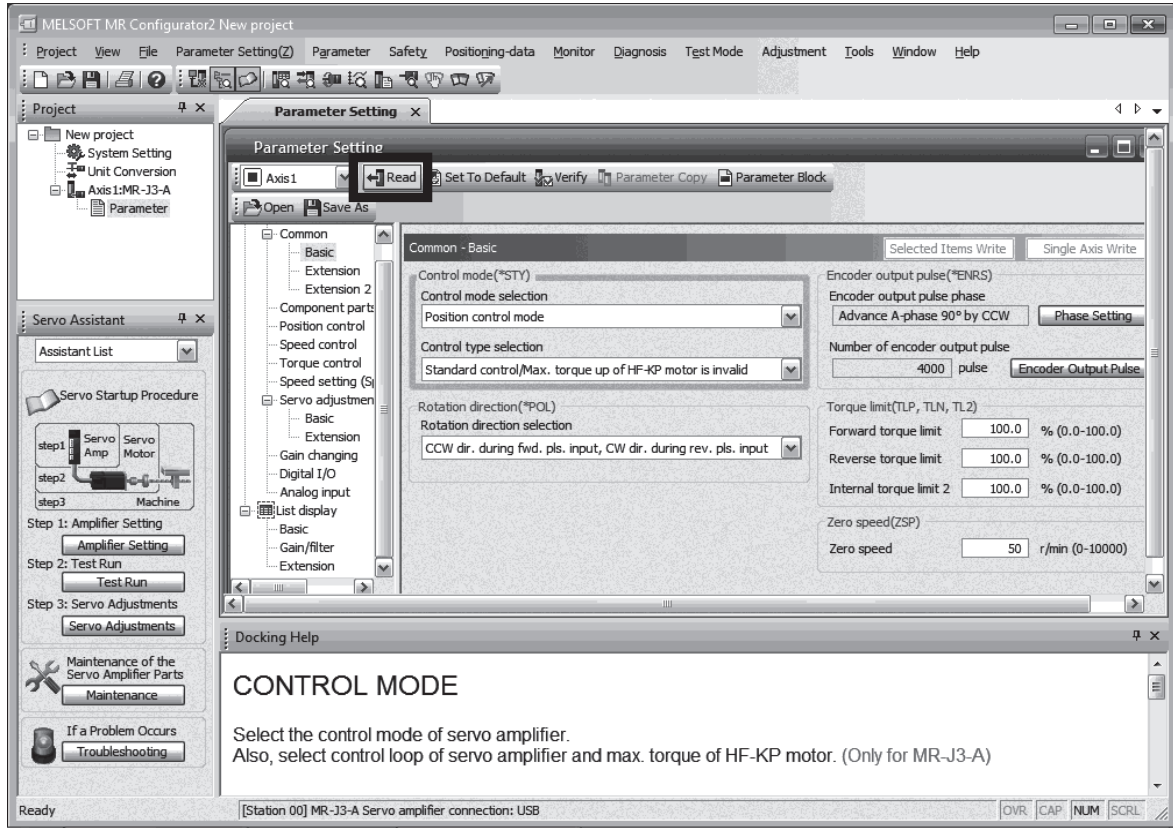

After reading the parameters is completed, select [Save As] to save the parameter file.

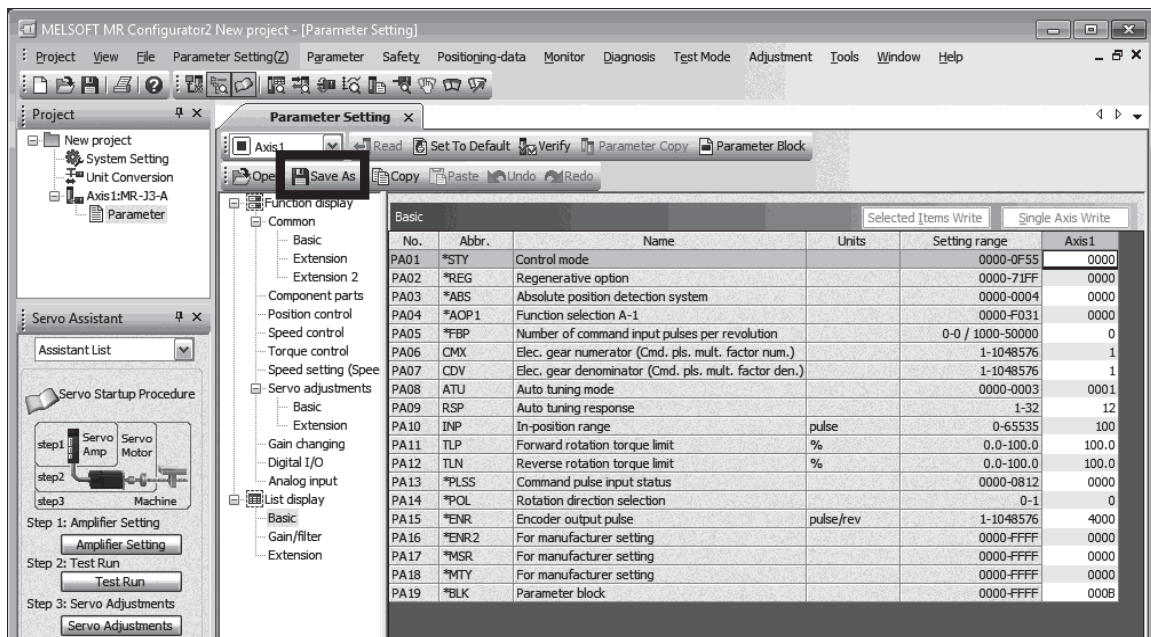

Part 8: Common Reference Material

2.2.4 Converting the parameters of MR-J3-_A_/MR-J3-_T_ and writing them to the MR-J4-_A_(-RJ)/MR-J4-_GF_ servo amplifier

- (1) Start MR Configurator2 (SW1DNC-MRC2-E).

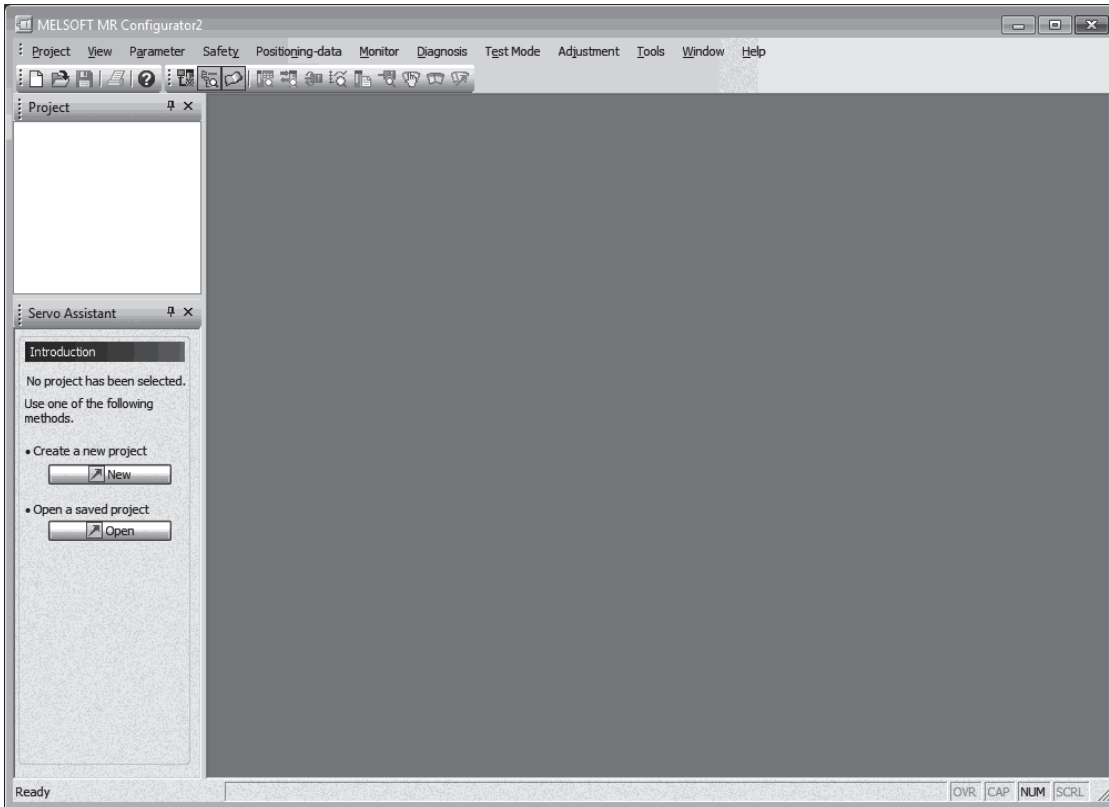

- (2) Create a new project.

Select [Project] - [New] from the menu to display the New Project dialog box. Select "MR-J4-A(-RJ)" or "MR-J4-GF(-RJ)" for Model.

The following figure shows the case where "MR-J4-A(-RJ)" is selected for the model.

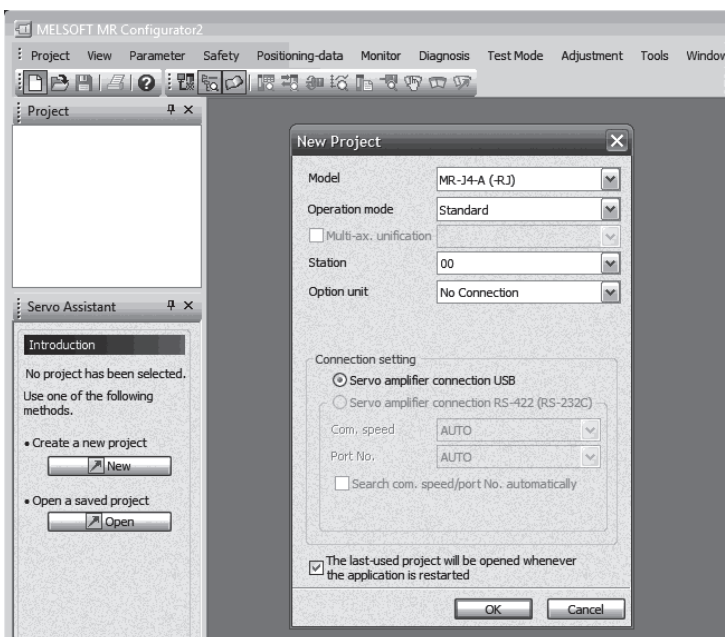

Part 8: Common Reference Material

- (3) Change MR-J3-_A_/MR-J3-_T_ parameters to MR-J4-_A_(-RJ)/MR-J4-_GF_(-RJ) parameters. Select [Parameter] - [Parameter Converter] from the menu to display the parameter converter screen. Then click the [Open file] button and specify the user file that was saved with the operation in (3) of Section 2.2.3. The following figure shows the case where "MR-J4-A(-RJ)" is selected for the model.

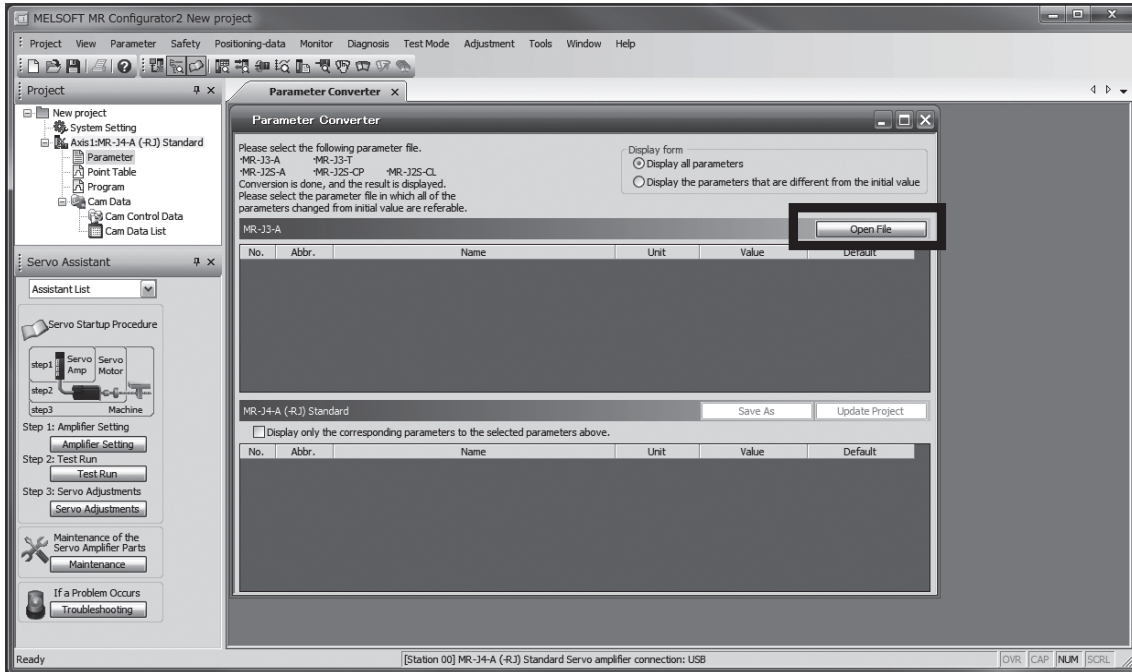

Click [Update Project].

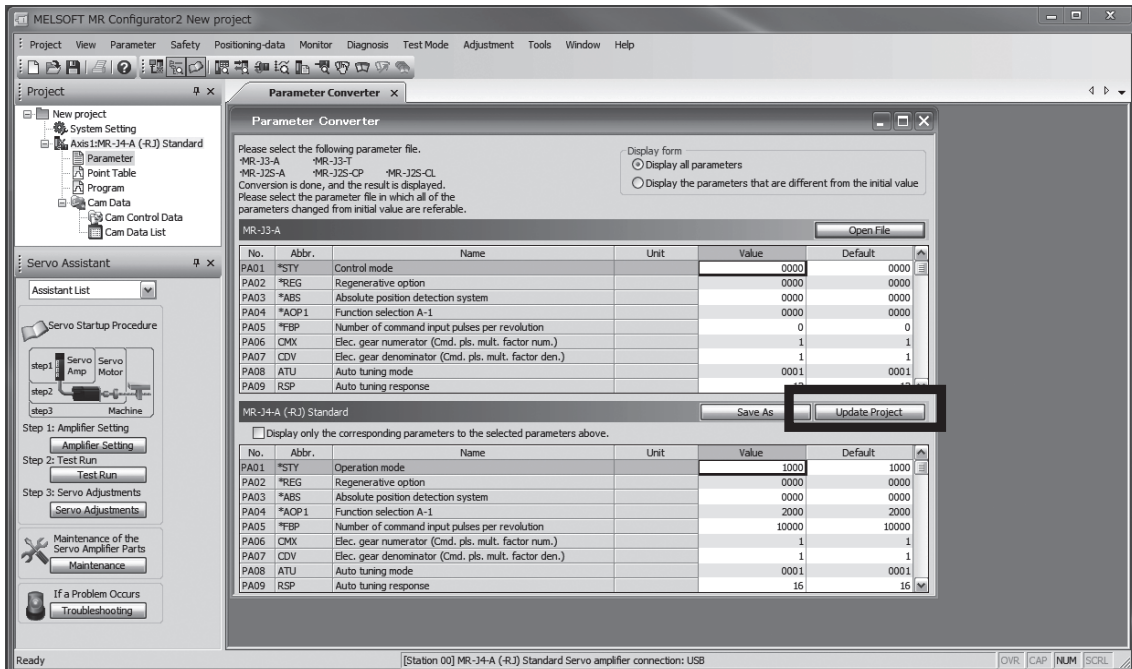

Part 8: Common Reference Material

- (4) Write the changed parameters to the MR-J4-_A_(-RJ)/MR-J4-_GF_(-RJ) servo amplifier. Select [Parameter] - [Parameter Setting] from the menu to display the parameter setting screen. Connect the MR-J4-_A_(-RJ)/MR-J4-_GF_(-RJ) servo amplifier to a personal computer and click the [Single Axis Write] button. The parameter values will be written to the MR-J4-_A_(-RJ)/MR-J4-_GF_(-RJ) servo amplifier.

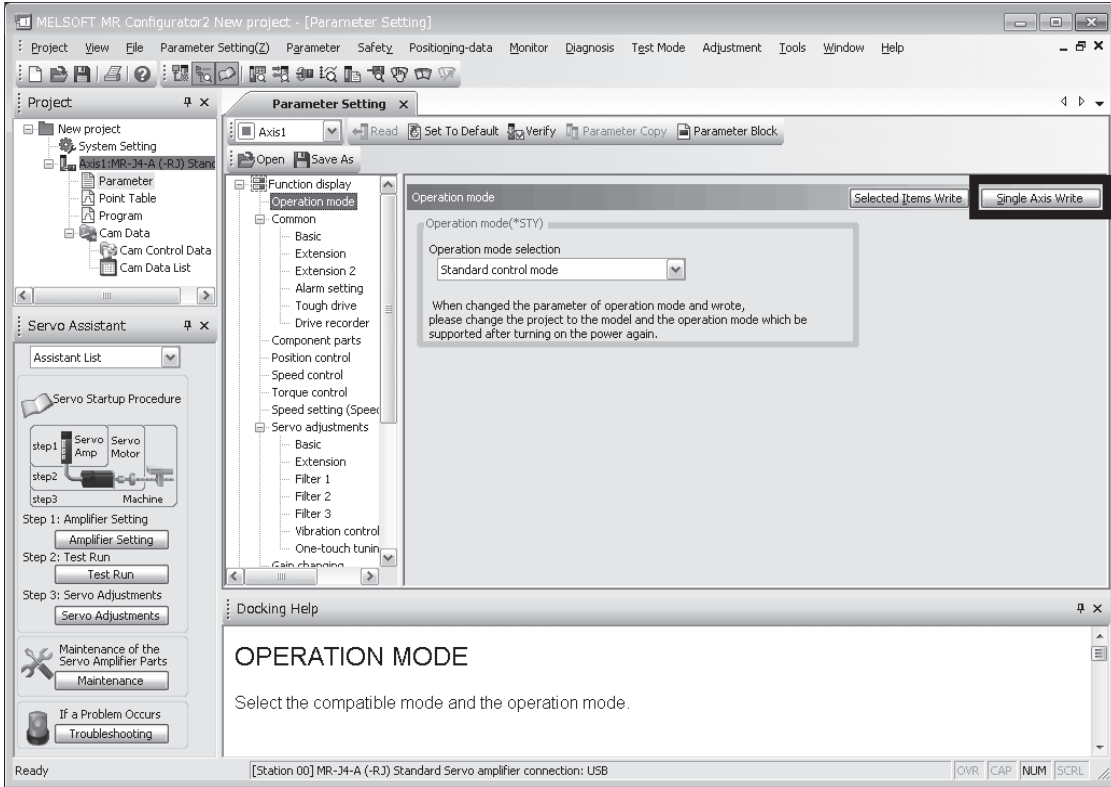

Note: The servo gain is not perfectly equal.
Refer to the MR Configurator2 (SW1DNC-MRC2-E) help for details.

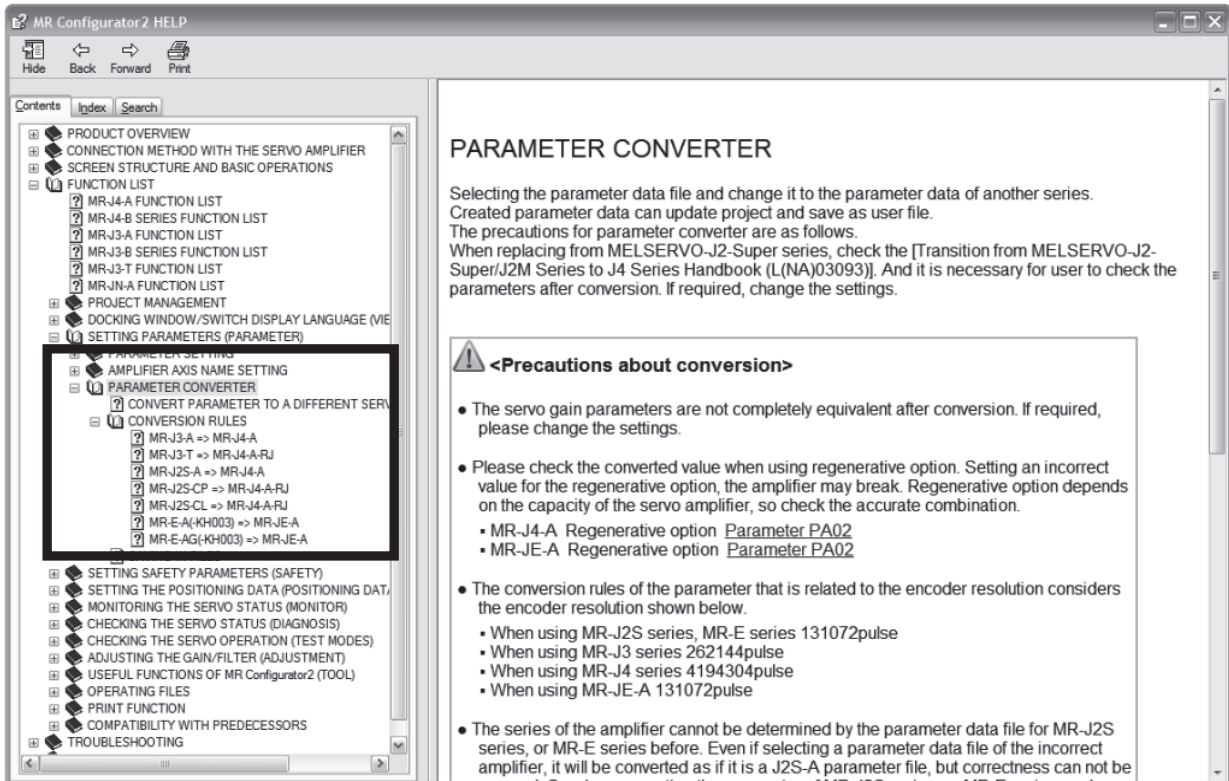

Part 8: Common Reference Material

2.2.5 Conversion rules (MR-J3-_A_ => MR-J4-_A_)

The following table shows the servo parameter conversion rules from MR-J3-_A_ to MR-J4-_A_. Servo parameters not specified in the following table will be set to the initial values.

POINT
<ul style="list-style-type: none"> ● Because the servo parameters of MR-J3-_A_ and those of MR-J4-_A_ are not completely interchangeable, the conversion rules may not be applied. Check the operations and review the settings as necessary. ● The value of the parameter writing after parameter conversion is the initial value. <ul style="list-style-type: none"> ▪ MR-J4-_A_ : [Pr. PA19] = "00AAh" ● Various offset parameters cannot be converted. Change the settings as necessary. <ul style="list-style-type: none"> ▪ MR-J4-_A_ : [Pr. PC37] to [Pr. PC40] ● The following parameters of MR-J4-_A_ are compatible with the servo amplifier's software version A3 or later. The software version can be checked in the system configuration of MR Configurator 2. <ul style="list-style-type: none"> ▪ MR-J4-_A_ : [Pr. PA03 Absolute position detection system "_ _ _2h" (Absolute position detection system by communication)] ▪ MR-J4-_A_ : [Pr. PC21 RS-422 communication function selection] ● When the geared servo motor is replaced, the reduction ratio may differ before and after the replacement. Check the specifications of the servo motor and review the electronic gear settings as necessary. <ul style="list-style-type: none"> ▪ MR-J4-_A_ : [Pr. PA05] to [Pr. PA07] ● The following parameters will be converted to values according to the encoder resolution of the servo motor. <ul style="list-style-type: none"> ▪ MR-J4-_A_ : [Pr. PA10]/[Pr. PA15]/[Pr. PA21] <p>When "HG series" is selected for servo motor series, the parameters will be converted to values according to the encoder resolution of the HG motor.</p> <p>When "HF-_P/HC-_P/HA-_P series" is selected for servo motor series, the parameters will be converted to values according to the encoder resolution of the HF-_P/HC-_P/HA-_P servo motor.</p> <p>Servo motor series can be selected in MR Configurator2 with software version 1.72A or later.</p>

MR-J3-_A_				MR-J4-_A_			Conversion rule
No.	Name	Type	Target	No.	Type	Target	
PA01	Control mode	Hex	__ _ X	PA01	Hex	__ _ X	The setting value will be maintained.
			_ X _ _	PA01	Hex	_ X _ _	When "HG series" is selected for servo motor series, the setting value will not be maintained. When "HF-_P/HC-_P/HA-_P series" is selected for servo motor series, the setting value will be converted as follows: _ 0 _ _ will be changed to _ 2 _ _. _ 4 _ _ will be changed to _ 2 _ _. Otherwise, _ 0 _ _ will be set. Servo motor series can be selected in MR Configurator2 with software version 1.72A or later.
PA02	Regenerative option	Hex	__ XX	PA02	Hex	__ XX	The setting value will be maintained.
PA03	Absolute position detection system	Hex	__ _ X	PA03	Hex	__ _ X	01 _ _ will be changed to __ 01. 02 _ _ will be changed to __ 02. Otherwise, __ 00 will be set.

Part 8: Common Reference Material

MR-J3- _A_				MR-J4- _A_			Conversion rule
No.	Name	Type	Target	No.	Type	Target	
PA04	Function selection A-1	Hex	___X	PD24	Hex	__XX	01__ will be changed to __05. (MBR) The setting value other than above will not be maintained.
PA05	Number of command input pulses per revolution	Dec	-	PA05	Dec	-	0 will be changed to 10000. Otherwise, the setting value will be maintained.
				PA21	Hex	X___	When "HG series" is selected for servo motor series, the setting value will be converted as follows: 0 will be changed to 2___. Otherwise, 1___ will be set. Servo motor series can be selected in MR Configurator2 with software version 1.72A or later.
PA06	Electronic gear numerator (Command pulse multiplying factor numerator)	Dec	-	PA06	Dec	-	The setting value will be maintained.
PA07	Electronic gear denominator (Command pulse multiplying factor denominator)	Dec	-	PA07	Dec	-	The setting value will be maintained.
PA08	Auto tuning mode	Hex	___X	PA08	Hex	___X	The setting value will be maintained.
PA09	Auto tuning response	Dec	-	PA09	Dec	-	The value 4 is added to the setting value.
PA10	In-position range	Dec	-	PA10	Dec	-	The setting value will be maintained.
PA11	Forward rotation torque limit	Dec	-	PA11	Dec	-	The setting value will be maintained.
PA12	Reverse rotation torque limit	Dec	-	PA12	Dec	-	The setting value will be maintained.
PA13	Command pulse input form	Hex	__XX	PA13	Hex	__XX	The setting value will be maintained.
PA14	Rotation direction selection	Dec	-	PA14	Dec	-	The setting value will be maintained.
PA15	Encoder output pulse	Dec	-	PA15	Dec	-	When "HG series" is selected for servo motor series, the setting value will be converted as follows: (1) When the setting value of PC19 is __1_, the value increases by 16 times. (2) When the setting value of PC19 is other than __1_, the setting value will be maintained. When "HF- _P/HC- _P/HA- _P series" is selected for servo motor series, the setting value will be maintained. Servo motor series can be selected in MR Configurator2 with software version 1.72A or later.
PB01	Adaptive tuning mode (Adaptive filter II)	Hex	___X	PB01	Hex	___X	The setting value will be maintained.
PB02	Vibration suppression control tuning mode (Advanced vibration suppression control)	Hex	___X	PB02	Hex	___X	The setting value will be maintained.
PB03	Position command acceleration/deceleration time constant (Position smoothing)	Dec	-	PB03	Dec	-	The setting value will be maintained.
PB04	Feed forward gain	Dec	-	PB04	Dec	-	The setting value will be maintained.
PB06	Ratio of load inertia moment to servo motor inertia moment	Dec	-	PB06	Dec	-	One decimal place will be added.
PB07	Model loop gain	Dec	-	PB07	Dec	-	One decimal place will be added.
PB08	Position loop gain	Dec	-	PB08	Dec	-	One decimal place will be added.
PB09	Speed loop gain	Dec	-	PB09	Dec	-	The setting value will be maintained.
PB10	Speed integral compensation	Dec	-	PB10	Dec	-	The setting value will be maintained.

Hex: hexadecimal parameter; Dec: decimal parameter

Part 8: Common Reference Material

MR-J3- _A_				MR-J4- _A_			Conversion rule
No.	Name	Type	Target	No.	Type	Target	
PB11	Speed differential compensation	Dec	-	PB11	Dec	-	The setting value will be maintained.
PB13	Machine resonance suppression filter 1	Dec	-	PB13	Dec	-	The setting value will be maintained.
PB14	Notch shape selection 1	Hex	_XX_	PB14	Hex	_XX_	The setting value will be maintained.
PB15	Machine resonance suppression filter 2	Dec	-	PB15	Dec	-	The setting value will be maintained.
PB16	Notch shape selection 2	Hex	_XXX	PB16	Hex	_XXX	The setting value will be maintained.
PB17	Automatic setting parameter	Hex	__XX	PB17	Hex	__XX	__01 will be changed to __00. Otherwise, the setting value will be maintained.
			_X__			_X__	The setting value will be maintained.
PB18	Low-pass filter setting	Dec	-	PB18	Dec	-	The setting value will be maintained.
PB19	Vibration suppression control vibration frequency setting	Dec	-	PB19	Dec	-	The setting value will be maintained.
PB20	Vibration suppression control resonance frequency setting	Dec	-	PB20	Dec	-	The setting value will be maintained.
PB23	Low-pass filter selection	Hex	__X_	PB23	Hex	__X_	The setting value will be maintained.
PB24	Slight vibration suppression control selection	Hex	___X	PB24	Hex	___X	The setting value will be maintained.
PB25	Function selection B-1	Hex	__X_	PB25	Hex	__X_	The setting value will be maintained.
PB26	Gain changing selection	Hex	__XX	PB26	Hex	__XX	The setting value will be maintained.
PB27	Gain changing condition	Dec	-	PB27	Dec	-	The setting value will be maintained.
PB28	Gain changing time constant	Dec	-	PB28	Dec	-	The setting value will be maintained.
PB29	Gain changing ratio of load inertia moment to servo motor inertia moment	Dec	-	PB29	Dec	-	One decimal place will be added.
PB30	Gain changing position loop gain	Dec	-	PB30	Dec	-	One decimal place will be added.
PB31	Gain changing speed loop gain	Dec	-	PB31	Dec	-	The setting value will be maintained.
PB32	Gain changing speed integral compensation	Dec	-	PB32	Dec	-	The setting value will be maintained.
PB33	Gain changing vibration suppression control vibration frequency setting	Dec	-	PB33	Dec	-	The setting value will be maintained.
PB34	Gain changing vibration suppression control resonance frequency setting	Dec	-	PB34	Dec	-	The setting value will be maintained.
PC01	Acceleration time constant	Dec	-	PC01	Dec	-	The setting value will be maintained.
PC02	Deceleration time constant	Dec	-	PC02	Dec	-	The setting value will be maintained.
PC03	S-pattern acceleration/deceleration time constant	Dec	-	PC03	Dec	-	The setting value will be maintained.
PC04	Torque command time constant	Dec	-	PC04	Dec	-	The setting value will be maintained.
PC05	Internal speed command 1	Dec	-	PC05	Dec	-	The setting value will be maintained.
	Internal speed limit 1						
PC06	Internal speed command 2	Dec	-	PC06	Dec	-	The setting value will be maintained.
	Internal speed limit 2						
PC07	Internal speed command 3	Dec	-	PC07	Dec	-	The setting value will be maintained.
	Internal speed limit 3						
PC08	Internal speed command 4	Dec	-	PC08	Dec	-	The setting value will be maintained.
	Internal speed limit 4						
PC09	Internal speed command 5	Dec	-	PC09	Dec	-	The setting value will be maintained.
	Internal speed limit 5						
PC10	Internal speed command 6	Dec	-	PC10	Dec	-	The setting value will be maintained.
	Internal speed limit 6						
PC11	Internal speed command 7	Dec	-	PC11	Dec	-	The setting value will be maintained.
	Internal speed limit 7						
PC02	Deceleration time constant	Dec	-	PC02	Dec	-	The setting value will be maintained.
PC03	S-pattern acceleration/deceleration time constant	Dec	-	PC03	Dec	-	The setting value will be maintained.

Hex: hexadecimal parameter; Dec: decimal parameter

Part 8: Common Reference Material

MR-J3-_A_				MR-J4-_A_			Conversion rule
No.	Name	Type	Target	No.	Type	Target	
PC04	Torque command time constant	Dec	-	PC04	Dec	-	The setting value will be maintained.
PC05	Internal speed command 1	Dec	-	PC05	Dec	-	The setting value will be maintained.
	Internal speed limit 1						
PC06	Internal speed command 2	Dec	-	PC06	Dec	-	The setting value will be maintained.
	Internal speed limit 2						
PC07	Internal speed command 3	Dec	-	PC07	Dec	-	The setting value will be maintained.
	Internal speed limit 3						
PC08	Internal speed command 4	Dec	-	PC08	Dec	-	The setting value will be maintained.
	Internal speed limit 4						
PC09	Internal speed command 5	Dec	-	PC09	Dec	-	The setting value will be maintained.
	Internal speed limit 5						
PC10	Internal speed command 6	Dec	-	PC10	Dec	-	The setting value will be maintained.
	Internal speed limit 6						
PC11	Internal speed command 7	Dec	-	PC11	Dec	-	The setting value will be maintained.
	Internal speed limit 7						
PC12	Analog speed command maximum speed	Dec	-	PC12	Dec	-	The setting value will be maintained.
	Analog speed limit maximum speed						
PC13	Analog torque command maximum output	Dec	-	PC13	Dec	-	The setting value will be maintained.
PC14	Analog monitor 1 output	Hex	__XX	PC14	Hex	__XX	The setting value will be maintained.
PC15	Analog monitor 2 output	Hex	__XX	PC15	Hex	__XX	The setting value will be maintained.
PC16	Electromagnetic brake sequence output	Dec	-	PC16	Dec	-	The setting value will be maintained.
PC17	Zero speed	Dec	-	PC17	Dec	-	The setting value will be maintained.
PC18	Alarm history clear	Hex	___X	PC18	Hex	___X	The setting value will be maintained.
PC19	Encoder output pulses selection	Hex	__XX	PC19	Hex	__XX	The setting value will be maintained.
PC20	Station number setting	Dec	-	PC20	Dec	-	The setting value will be maintained.
PC21	Communication function selection	Hex	_XX_	PC21	Hex	_XX_	The setting value will be maintained.
PC22	Function selection C-1	Hex	X___	PC22	Hex	X___	The setting value will be maintained.
PC23	Function selection C-2	Hex	___X	PC23	Hex	___X	The setting value will be maintained.
			XX__			XX__	The setting value will be maintained.
PC24	Function selection C-3	Hex	___X	PC24	Hex	___X	The setting value will be maintained.
PC26	Function selection C-5	Hex	___X	PC26	Hex	___X	The setting value will be maintained.
PC27	Function selection C-6	Hex	___X	PC27	Hex	___X	The setting value will be maintained.
PC30	Acceleration time constant 2	Dec	-	PC30	Dec	-	The setting value will be maintained.
PC31	Deceleration time constant 2	Dec	-	PC31	Dec	-	The setting value will be maintained.
PC32	Command pulse multiplying factor numerator 2	Dec	-	PC32	Dec	-	The setting value will be maintained.
PC33	Command pulse multiplying factor numerator 3	Dec	-	PC33	Dec	-	The setting value will be maintained.
PC34	Command pulse multiplying factor numerator 4	Dec	-	PC34	Dec	-	The setting value will be maintained.
PC35	Internal torque limit 2	Dec	-	PC35	Dec	-	The setting value will be maintained.
PC36	Status display selection	Hex	__XX	PC36	Hex	__XX	__1_ will be changed to __00. Otherwise, the setting value will be maintained.
			_X__			_X__	The setting value will be maintained.
PD01	Input signal automatic ON selection 1	Hex	_XXX	PD01	Hex	_XXX	The setting value will be maintained.
PD03	Input signal device selection 1 (CN1-15)	Hex	____XXXX	PD03	Hex	XXXX	The setting value will be maintained.
			__XX__	PD04	Hex	__XX	The setting value will be maintained.
PD04	Input signal device selection 2 (CN1-16)	Hex	____XXXX	PD05	Hex	XXXX	The setting value will be maintained.
			__XX__	PD06	Hex	__XX	The setting value will be maintained.
PD05	Input signal device selection 3 (CN1-17)	Hex	____XXXX	PD07	Hex	XXXX	The setting value will be maintained.
			__XX__	PD08	Hex	__XX	The setting value will be maintained.
PD06	Input signal device selection 4 (CN1-18)	Hex	____XXXX	PD09	Hex	XXXX	The setting value will be maintained.
			__XX__	PD10	Hex	__XX	The setting value will be maintained.

Hex: hexadecimal parameter; Dec: decimal parameter

Part 8: Common Reference Material

MR-J3-_A_				MR-J4-_A_			Conversion rule
No.	Name	Type	Target	No.	Type	Target	
PD07	Input signal device selection 5 (CN1-19)	Hex	_____XXXX	PD11	Hex	XXXX	The setting value will be maintained.
			__XX_____	PD12	Hex	__XX	The setting value will be maintained.
PD08	Input signal device selection 6 (CN1-41)	Hex	_____XXXX	PD13	Hex	XXXX	The setting value will be maintained.
			__XX_____	PD14	Hex	__XX	The setting value will be maintained.
PD10	Input signal device selection 8 (CN1-43)	Hex	_____XXXX	PD17	Hex	XXXX	The setting value will be maintained.
			__XX_____	PD18	Hex	__XX	The setting value will be maintained.
PD11	Input signal device selection 9 (CN1-44)	Hex	_____XXXX	PD19	Hex	XXXX	The setting value will be maintained.
			__XX_____	PD20	Hex	__XX	The setting value will be maintained.
PD12	Input signal device selection 10 (CN1-45)	Hex	_____XXXX	PD21	Hex	XXXX	The setting value will be maintained.
			__XX_____	PD22	Hex	__XX	The setting value will be maintained.
PD13	Output signal device selection 1(CN1-22)	Hex	__XX	PD23	Hex	__XX	The setting value will be maintained.
PD14	Output signal device selection 2(CN1-23)	Hex	__XX	PD24	Hex	__XX	PA04 = ____ 1 will be changed to ____ 05. (MBR) Otherwise, the setting value will be maintained.
PD15	Output signal device selection 3(CN1-24)	Hex	__XX	PD25	Hex	__XX	The setting value will be maintained.
PD16	Output signal device selection 4(CN1-25)	Hex	__XX	PD26	Hex	__XX	The setting value will be maintained.
PD18	Output signal device selection 6(CN1-49)	Hex	__XX	PD28	Hex	__XX	The setting value will be maintained.
PD19	Input filter setting	Hex	___X	PD29	Hex	___X	___ 1 will be changed to ___ 2. ___ 2 will be changed to ___ 4. ___ 3 will be changed to ___ 4. Otherwise, the setting value will be maintained.
PD20	Function selection D-1	Hex	__XX	PD30	Hex	__XX	The setting value will be maintained.
PD22	Function selection D-3	Hex	___X	PD32	Hex	___X	The setting value will be maintained.
PD24	Function selection D-5	Hex	__XX	PD34	Hex	__XX	The setting value will be maintained.

Hex: hexadecimal parameter; Dec: decimal parameter

Part 8: Common Reference Material

2.2.6 Parameters that need to be checked after parameter conversion

No.	Name	Initial value	Setting value	Description
PA03	Absolute position detection system	-	-	Absolute position detection system selection When the setting before conversion is "___2: Enabled (absolute position detection system by communication)", this parameter can be set for MR-J4-_A_ with software version A3 or later. A parameter error will occur when the software version A2 or earlier is used.
PA04	Function selection A-1	2000h	0___h	Forced stop deceleration function selection To configure the same operation status as those for MR-J3-_A_, select "Forced stop deceleration function disabled (EM1)"
PA06	Electronic gear numerator	-	-	For geared servo motors, the actual reduction ratio may differ before and after replacement. If they are different, consider the actual reduction ratio when setting.
PA07	Electronic gear denominator	-	-	
PA09	Auto tuning response	-	-	Auto tuning response setting Adjust the gain value again after the replacement.
PA10	In-position range	-	-	When the value is over 4095 pulses with the in-position range unit selection ([Pr. PC24]) of MR-J3-_A_ set to "___1: Servo motor encoder unit", the value will be converted to 65535 pulses. To use the same in-position range as before, set "___0: Command input unit" and a value within the in-position range considering the electronic gear setting value.
PC21	RS-422 Absolute position detection system	-	-	<ul style="list-style-type: none"> RS-422 communication baud rate selection This parameter can be set when MR-J4-_A_ with software version A3 or later for the conversion from MR-J3-_A_. A parameter error will occur when the software version A2 or earlier is used. RS-422 communication response delay time (supported by software version A3 or later)
PC37	Absolute position detection system/ Analog speed limit offset	-	-	Not converted by the parameter converter function. Set the value as required.
PC38	Analog torque command offset/ Analog torque limit offset	-	-	Set the value as required.
PC39	Analog monitor 1 offset	-	-	Set the value as required.
PC40	Analog monitor 2 offset	-	-	Set the value as required.
PD29	Input signal filter setting	-	-	When the setting before conversion has exceeded 3.55 [ms], the setting will be converted to "4: 3.555 [ms]". When MR-J4-_A_ with the software version B3 or later is used, "6: 5.333 [ms]" can be set.

Note. For items that have no setting values listed in the table, refer to "Part 2: Review on Replacement of MR-J3-_A_ with MR-J4-_A_".

Part 8: Common Reference Material

2.2.7 Conversion rules (MR-J3-_T_(DIO Command/ Serial communication operation) => MR-J4-_A_-RJ)

The following table shows the servo parameter conversion rules from MR-J3-_T_(DIO Command/ Serial communication operation) to MR-J4-_A_-RJ.

Servo parameters not specified in the following table will be set to the initial values.

POINT
<ul style="list-style-type: none"> ● This parameter can be set when MR-J4-_A_-RJ with software version A3 or later is used for the conversion from MR-J3-_T_. The software version can be checked in the system configuration of MR Configurator 2. ● The setting value of "parameter writing inhibit" after the conversion from MR-J3-_T_ is as follows: <ul style="list-style-type: none"> ▪ MR-J4-_A_-RJ: [Pr. PA19] = "00ABh" ● Various parameters cannot be converted. Change the settings as necessary. <ul style="list-style-type: none"> ▪ MR-J4-_A_-RJ: [Pr. Po15]/[Pr. Po16]/[Pr. Po21]/[Pr. Po22] ● Servo motor series can be selected in MR Configurator2 with software version 1.72A or later. ● Because the servo parameters of MR-J3-_T_ and those of MR-J4-_A_-RJ are not completely interchangeable, the conversion rules may not be applied. Check the operations and review the settings as necessary. ● If not using a conversion cable, disable the I/O signal assignment conversion of the parameter converter function. The parameters related to I/O signal assignment are not converted, so review the wiring and settings as required. ● If using a conversion cable, enable the I/O signal assignment conversion of the parameter converter function. The parameters related to I/O signal assignment are converted in accordance with the control signal connection of the conversion cable. <ul style="list-style-type: none"> ▪ MR-J4-_A_-RJ: [Pr. PD03] to [Pr. PD28] Contact Mitsubishi Electric System & Service Co., Ltd. for the specifications of the conversion cable. ● The parameter converter function converts the parameters related to the input/output signal assignment of the MR-D01 extension I/O unit regardless of whether the assignment conversion (parameter converter function) is enabled or disabled. <ul style="list-style-type: none"> ▪ MR-J4-_A_-RJ: [Pr. Po02] to [Pr. Po09] ● When the geared servo motor is replaced, the reduction ratio may differ before and after the replacement. Check the specifications of the servo motor and review the electronic gear settings as necessary. <ul style="list-style-type: none"> ▪ MR-J4-_A_-RJ: [Pr. PA06] to [Pr. PA07] ● The following parameters will be converted to values according to the encoder resolution of the servo motor. <ul style="list-style-type: none"> ▪ MR-J4-_A_-RJ: [Pr. PA10]/[Pr. PA15]/[Pr. PA21]/[Pr. PC14] When "HG series" is selected for servo motor series, the parameters will be converted to values according to the encoder resolution of the HG motor. When "HF-_P/HC-_P/HA-_P series" is selected for servo motor series, the parameters will be converted to values according to the encoder resolution of the HF-_P/HC-_P/HA-_P servo motor.

Part 8: Common Reference Material

MR-J3-_T_				MR-J4-_A_-RJ			Conversion rule
No.	Name	Type	Target	No.	Type	Target	
PA01	Control mode	Hex	___X	PT01	Hex	___X	The setting value will be maintained.
			_X__	PA01	Hex	_X__	When "HG series" is selected for servo motor series, the setting value will not be maintained. When "HF-_P/HC-_P/HA-_P series" is selected for servo motor series, the setting value will be converted as follows: _0__ will be changed to _2__. Otherwise, _0__ will be set.
			X___			___X	0__ will be changed to __6. The setting value other than above will not be maintained.
PA02	Regenerative option	Hex	__XX	PA02	Hex	__XX	The setting value will be maintained.
PA03	Absolute position detection system	Hex	___X	PA03	Hex	___X	The setting value will be maintained.
PA04	Function selection A-1	Hex	___X	PT02	Hex	___X	The setting value will be maintained.
PA05	Feeding function selection	Hex	___X	PT03	Hex	___X	The setting value will be maintained.
			__X_			__X_	The setting value will be maintained.
			_X__	PC29	Hex	__X_	The setting value will be maintained.
PA06	Electric gear numerator Number of gear teeth on machine side	Dec	-	PA06	Dec	-	The setting value will be maintained.
PA07	Electric gear denominator Number of gear teeth on servo motor side	Dec	-	PA07	Dec	-	The setting value will be maintained.
PA08	Auto tuning mode	Hex	___X	PA08	Hex	___X	The setting value will be maintained.
PA09	Auto tuning response	Dec	-	PA09	Dec	-	The value 4 is added to the setting value.
PA10	In-position range	Dec	-	PA10	Dec	-	When "HG series" is selected for servo motor series, the setting value will be converted as follows: When PC24 is set to ___0, the setting value will be maintained. When PC24 is set to ___1, the setting value will be multiplied by 16. The above value will be clamped at 65535. When "HF-_P/HC-_P/HA-_P series" is selected for servo motor series, the setting value will be maintained.
PA11	Forward rotation torque limit	Dec	-	PA11	Dec	-	The setting value will be maintained.
PA12	Reverse rotation torque limit	Dec	-	PA12	Dec	-	The setting value will be maintained.
PA14	Rotation direction selection	Dec	-	PA14	Dec	-	The setting value will be maintained.
PA15	Encoder output pulses	Dec	-	PA15	Dec	-	When "HG series" is selected for servo motor series, the setting value will be converted as follows: (1) When the setting value of PC19 is __1_, the value increases by 16 times. (2) When the setting value of PC19 is other than __1_, the setting value will be maintained. When "HF-_P/HC-_P/HA-_P series" is selected for servo motor series, the setting value will be maintained.
PA19	Parameter writing inhibit	Hex	XXXX	PA19	Hex	XXXX	The setting value will be 00AB.
PB01	Adaptive tuning mode (adaptive filter II)	Hex	___X	PB01	Hex	___X	The setting value will be maintained.
PB02	Vibration suppression control tuning mode (advanced vibration suppression control)	Hex	___X	PB02	Hex	___X	The setting value will be maintained.
PB04	Feed forward gain	Dec	-	PB04	Dec	-	The setting value will be maintained.

Part 8: Common Reference Material

MR-J3-_T_				MR-J4-_A_-RJ			Conversion rule
No.	Name	Type	Target	No.	Type	Target	
PB06	Ratio of load inertia to servo motor inertia	Dec	-	PB06	Dec	-	One decimal place will be added.
PB07	Model loop gain	Dec	-	PB07	Dec	-	One decimal place will be added.
PB08	Position loop gain	Dec	-	PB08	Dec	-	One decimal place will be added.
PB09	Speed loop gain	Dec	-	PB09	Dec	-	The setting value will be maintained.
PB10	Speed integral compensation	Dec	-	PB10	Dec	-	The setting value will be maintained.
PB11	Speed differential compensation	Dec	-	PB11	Dec	-	The setting value will be maintained.
PB13	Machine resonance suppression filter 1	Dec	-	PB13	Dec	-	The setting value will be maintained.
PB14	Notch shape selection 1	Hex	__ X __	PB14	Hex	__ X __	The setting value will be maintained.
			_ X _ _			_ X _ _	The setting value will be maintained.
PB15	Machine resonance suppression filter 2	Dec	-	PB15	Dec	-	The setting value will be maintained.
PB16	Notch shape selection 2	Hex	__ _ X	PB16	Hex	__ _ X	The setting value will be maintained.
			__ X _			__ X _	The setting value will be maintained.
			_ X _ _			_ X _ _	The setting value will be maintained.
PB17	Automatic setting parameter	Hex	__ XX	PB17	Hex	__ XX	__ 01 will be changed to __ 00. The setting value other than above will be maintained.
			_ X _ _			_ X _ _	The setting value will be maintained.
PB18	Low-pass filter setting	Dec	-	PB18	Dec	-	The setting value will be maintained.
PB19	Vibration frequency for vibration suppression control	Dec	-	PB19	Dec	-	The setting value will be maintained.
PB20	Resonance frequency for vibration suppression control	Dec	-	PB20	Dec	-	The setting value will be maintained.
PB23	Low-pass filter selection	Hex	__ X __	PB23	Hex	__ X __	The setting value will be maintained.
PB24	Slight vibration suppression control selection	Hex	__ _ X	PB24	Hex	__ _ X	The setting value will be maintained.
PB26	Gain switching selection	Hex	__ _ X	PB26	Hex	__ _ X	The setting value will be maintained.
			__ X _			__ X _	The setting value will be maintained.
PB27	Gain switching condition	Dec	-	PB27	Dec	-	The setting value will be maintained.
PB28	Gain switching time constant	Dec	-	PB28	Dec	-	The setting value will be maintained.
PB29	Load to motor inertia ratio after gain switching	Dec	-	PB29	Dec	-	One decimal place will be added.
PB30	Position loop gain after gain switching	Dec	-	PB30	Dec	-	One decimal place will be added.
PB31	Speed loop gain after gain switching	Dec	-	PB31	Dec	-	The setting value will be maintained.
PB32	Speed integral compensation after gain switching	Dec	-	PB32	Dec	-	The setting value will be maintained.
PB33	Vibration frequency for vibration suppression control after gain switching	Dec	-	PB33	Dec	-	The setting value will be maintained.
PB34	Resonance frequency for vibration suppression control after gain switching	Dec	-	PB34	Dec	-	The setting value will be maintained.
PC02	Home position return type	Hex	__ _ X	PT04	Hex	__ _ X	The setting value will be maintained.
PC03	Home position return direction	Hex	__ _ X	PT04	Hex	__ X _	The setting value will be maintained.
PC04	Home position return speed	Dec	-	PT05	Dec	-	The setting value will be maintained.
PC05	Creep speed	Dec	-	PT06	Dec	-	The setting value will be maintained.
PC06	Home position shift distance	Dec	-	PT07	Dec	-	The setting value will be maintained.
PC07	Home position return position data	Dec	-	PT08	Dec	-	The setting value will be maintained.
PC08	Travel distance after proximity dog	Dec	-	PT09	Dec	-	The setting value will be maintained.
PC09	Stopper type home position return stopper time	Dec	-	PT10	Dec	-	The setting value will be maintained.
PC10	Stopper type home position return torque limit value	Dec	-	PT11	Dec	-	The setting value will be maintained.
PC11	Rough match output range	Dec	-	PT12	Dec	-	The setting value will be maintained.

Part 8: Common Reference Material

MR-J3-_T_				MR-J4-_A_-RJ			Conversion rule
No.	Name	Type	Target	No.	Type	Target	
PC12	Jog speed	Dec	-	PT13	Dec	-	The setting value will be maintained.
PC13	S-pattern acceleration/deceleration time constants	Dec	-	PC03	Dec	-	The setting value will be maintained.
PC14	Backlash compensation	Dec	-	PT14	Dec	-	When "HG series" is selected for servo motor series, the setting value will be multiplied by 16. The value will be clamped at 65535. When "HF-_P/HC-_P/HA-_P series" is selected for servo motor series, the setting value will be maintained.
PC16	Electromagnetic brake sequence output	Dec	-	PC16	Dec	-	The setting value will be maintained.
PC17	Zero speed	Dec	-	PC17	Dec	-	The setting value will be maintained.
PC18	Alarm history clear	Hex	__X	PC18	Hex	__X	The setting value will be maintained.
PC19	Encoder output pulses selection	Hex	___X	PC19	Hex	___X	The setting value will be maintained.
			__X_			__X_	The setting value will be maintained.
PC20	Station number setting	Dec	-	PC20	Dec	-	The setting value will be maintained.
PC21	RS-422 communication function selection	Hex	__X_	PC21	Hex	__X_	The setting value will be maintained.
			_X__			_X__	The setting value will be maintained.
PC22	Function selection C-1	Hex	X___	PC22	Hex	X___	The setting value will be maintained.
PC24	Function selection C-3	Hex	___X	PC24	Hex	___X	The setting value will be maintained.
PC26	Function selection C-5	Hex	___X	PC26	Hex	___X	The setting value will be maintained.
PC27	Function selection C-6	Hex	___X	PC27	Hex	___X	The setting value will be maintained.
PC28	Function selection C-7	Hex	___X	PT26	Hex	___X	The setting value will be maintained.
			__X_			__X_	The setting value will be maintained.
PC31	Software limit +	Dec	-	PT15	Dec	-	The setting value will be maintained.
PC32	Software limit +	Dec	-	PT16	Dec	-	The setting value will be maintained.
PC33	Software limit -	Dec	-	PT17	Dec	-	The setting value will be maintained.
PC34	Software limit -	Dec	-	PT18	Dec	-	The setting value will be maintained.
PC35	Internal torque limit 2	Dec	-	PC35	Dec	-	The setting value will be maintained.
PC37	Position range output address +	Dec	-	PT19	Dec	-	The setting value will be maintained.
PC38	Position range output address +	Dec	-	PT20	Dec	-	The setting value will be maintained.
PC39	Position range output address -	Dec	-	PT21	Dec	-	The setting value will be maintained.
PC40	Position range output address -	Dec	-	PT22	Dec	-	The setting value will be maintained.
PD01	Input signal automatic on selection 1	Hex	___X	PD01	Hex	___X	The setting value will be maintained.
			__X_			__X_	The setting value will be maintained.
			_X__			_X__	The setting value will be maintained.
			X___			X___	The setting value will be maintained.
PD03	Input signal automatic on selection 3	Hex	___X	PD41	Hex	___X	The setting value will be maintained.
			__X_			__X_	The setting value will be maintained.
			X___			X___	The setting value will be maintained.
PD04	Input signal automatic on selection 4	Hex	_X__	PD42	Hex	_X__	The setting value will be maintained.
			X___			X___	The setting value will be maintained.
PD06	Input signal device selection 2 (CN6-2)	Hex	__XX	PD22 (Note)	Hex	XX__	The setting value will be converted as shown in table 8.1. If the setting value is not listed in table 8.1, the value will be converted to 2B __. (DOG)

Note. If the I/O signal assignment conversion is disabled, the initial value is used. If the I/O signal assignment conversion is enabled, conversion is performed in accordance with the control signal connection of the conversion cable. Contact Mitsubishi Electric System & Service Co., Ltd. for the specifications of the conversion cable.

Part 8: Common Reference Material

MR-J3-__T__				MR-J4-__A__-RJ			Conversion rule
No.	Name	Type	Target	No.	Type	Target	
PD07	Input signal device selection 3 (CN6-3)	Hex	__XX	PD18 (Note)	Hex	XX__	The setting value will be converted as shown in table 8.1. If the setting value is not listed in table 8.1, the value will be converted to 0A__ (LSP)
PD08	Input signal device selection 4 (CN6-4)	Hex	__XX	PD20 (Note)	Hex	XX__	The setting value will be converted as shown in table 8.1. If the setting value is not listed in table 8.1, the value will be converted to 0B__ (LSN)
PD09	Output signal device selection 1 (CN6-14)	Hex	__XX	PD28 (Note)	Hex	__XX	The setting value will be converted as shown in table 8.2. If the setting value is not listed in table 8.2, the value will be converted to __02. (RD)
PD11	Output signal device selection 3 (CN6-16)	Hex	__XX	PD24 (Note)	Hex	__XX	The setting value will be converted as shown in table 8.2. If the setting value is not listed in table 8.2, the value will be converted to __24. (ZP)
PD16	Input polarity selection	Hex	___X	PT29	Hex	___X	The setting value will be maintained.
PD19	Input filter setting	Hex	___X	PD29	Hex	___X	The setting value will be maintained.
PD20	Function selection D-1	Hex	___X	PD30	Hex	___X	The setting value will be maintained.
			__X_			__X_	The setting value will be maintained.
			_X__			_X__	The setting value will be maintained.
PD22	Function selection D-3	Hex	___X	PD32	Hex	___X	___0 will be changed to ___2. ___1 will be changed to ___0. ___2 will be changed to ___1.
PD24	Function selection D-5	Hex	__X_	PD34	Hex	__X_	The setting value will be maintained.
Po02	MR-J3-D01 input signal device selection 1 (CN10-21, 26)	Hex	__XX	Po02	Hex	__XX	The setting value will be maintained.
			XX__			XX__	The setting value will be maintained regardless of whether conversion of the input/output signal assignment (parameter converter function) is enabled or disabled.

Note. If the I/O signal assignment conversion is disabled, the initial value is used. If the I/O signal assignment conversion is enabled, conversion is performed in accordance with the control signal connection of the conversion cable. Contact Mitsubishi Electric System & Service Co., Ltd. for the specifications of the conversion cable.

Part 8: Common Reference Material

MR-J3-_T_				MR-J4-_A_-RJ			Conversion rule
No.	Name	Type	Target	No.	Type	Target	
Po03	MR-J3-D01 input signal device selection 2 (CN10-27, 28)	Hex	__XX	Po03	Hex	__XX	The setting value will be maintained. The setting value will be maintained regardless of whether conversion of the input/output signal assignment (parameter converter function) is enabled or disabled.
			XX__			XX__	
Po04	MR-J3-D01 input signal device selection 3 (CN10-29, 30)	Hex	__XX	Po04	Hex	__XX	The setting value will be maintained. The setting value will be maintained regardless of whether conversion of the input/output signal assignment (parameter converter function) is enabled or disabled.
			XX__			XX__	
Po05	MR-J3-D01 input signal device selection 4 (CN10-31, 32)	Hex	__XX	Po05	Hex	__XX	The setting value will be maintained. The setting value will be maintained regardless of whether conversion of the input/output signal assignment (parameter converter function) is enabled or disabled.
			XX__			XX__	
Po06	MR-J3-D01 input signal device selection 5 (CN10-33, 34)	Hex	__XX	Po06	Hex	__XX	The setting value will be maintained. The setting value will be maintained regardless of whether conversion of the input/output signal assignment (parameter converter function) is enabled or disabled.
			XX__			XX__	
Po07	MR-J3-D01 input signal device selection 6 (CN10-35, 36)	Hex	__XX	Po07	Hex	__XX	The setting value will be maintained. The setting value will be maintained regardless of whether conversion of the input/output signal assignment (parameter converter function) is enabled or disabled.
			XX__			XX__	
Po08	MR-J3-D01 output signal device selection 1 (CN10-46, 47)	Hex	__XX	Po08	Hex	__XX	The setting value will be maintained. The setting value will be maintained regardless of whether conversion of the input/output signal assignment (parameter converter function) is enabled or disabled.
			XX__			XX__	
Po09	MR-J3-D01 output signal device selection 2 (CN10-48, 49)	Hex	__XX	Po09	Hex	__XX	The setting value will be maintained. The setting value will be maintained regardless of whether conversion of the input/output signal assignment (parameter converter function) is enabled or disabled.
			XX__			XX__	
Po10	Function selection O-1	Hex	___X	Po10	Hex	___X	The setting value will be maintained.
			_X__			_X__	The setting value will be maintained.
			X___			X___	The setting value will be maintained.
Po12	Function selection O-3	Hex	___X	Po12	Hex	___X	The setting value will be maintained.
			__X_			__X_	The setting value will be maintained.
Po13	MR-J3-D01 analog monitor output 1	Hex	___X	Po13	Hex	__XX	___ 0 will be changed to __ 00 ___ 1 will be changed to __ 01 ___ 2 will be changed to __ 02 ___ 3 will be changed to __ 03 ___ 4 will be changed to __ 04 ___ 5 will be changed to __ 0E ___ 6 will be changed to __ 06 ___ 7 will be changed to __ 07 ___ 8 will be changed to __ 08 ___ 9 will be changed to __ 09 ___ A will be changed to __ 0A ___ B will be changed to __ 0B ___ C will be changed to __ 0C ___ D will be changed to __ 0D

Part 8: Common Reference Material

MR-J3-_T_				MR-J4-_A_-RJ			Conversion rule
No.	Name	Type	Target	No.	Type	Target	
Po14	MR-J3-D01 analog monitor output 2	Hex	___X	Po14	Hex	__XX	___0 will be changed to __00 ___1 will be changed to __01 ___2 will be changed to __02 ___3 will be changed to __03 ___4 will be changed to __04 ___5 will be changed to __0E ___6 will be changed to __06 ___7 will be changed to __07 ___8 will be changed to __08 ___9 will be changed to __09 ___A will be changed to __0A ___B will be changed to __0B ___C will be changed to __0C ___D will be changed to __0D
-	Function selection A-3 (Note)	-	-	PA21	Hex	X___	When "HG series" is selected for servo motor series, the setting value will be converted to 2 ____. When "HF-_P/HC-_P/HA-_P series" is selected for servo motor series, the setting value will be converted to 0 ___.

Note. Parameter name for MR-J4-_A_-RJ.

Part 8: Common Reference Material

Table 8.1 Input conversion rule ([Pr. PD_ _])

MR-J3- T_	→	MR-J4- A_-RJ	Symbol
_ _ 00	→	00 _ _	No assigned function
_ _ 02	→	02 _ _	SON
_ _ 03	→	03 _ _	RES
_ _ 04	→	04 _ _	PC
_ _ 05	→	05 _ _	TL
_ _ 06	→	06 _ _	CR
_ _ 07	→	07 _ _	ST1
_ _ 08	→	08 _ _	ST2
_ _ 09	→	09 _ _	TL1
_ _ 0A	→	0A _ _	LSP
_ _ 0B	→	0B _ _	LSN
_ _ 0D	→	0D _ _	CDP
_ _ 20	→	20 _ _	MD0
_ _ 24	→	24 _ _	TP0
_ _ 25	→	25 _ _	TP1
_ _ 26	→	26 _ _	OVR
_ _ 27	→	27 _ _	TSTP
_ _ 28	→	28 _ _	DOG
_ _ 2F	→	2F _ _	SP3

Table 8.2 Output conversion rule ([Pr. PD_ _])

MR-J3- T_	→	MR-J4- A_-RJ	Symbol
_ _ 00	→	00 _ _	Always off
_ _ 02	→	02 _ _	RD
_ _ 03	→	03 _ _	ALM
_ _ 04	→	04 _ _	INP
_ _ 05	→	05 _ _	MBR
_ _ 06	→	06 _ _	DB
_ _ 07	→	07 _ _	TLC
_ _ 08	→	08 _ _	WNG
_ _ 09	→	09 _ _	BWNG
_ _ 0A	→	0A _ _	SA
_ _ 0C	→	0C _ _	ZSP
_ _ 0F	→	0F _ _	CDPS
_ _ 23	→	23 _ _	CPO
_ _ 24	→	24 _ _	ZP
_ _ 25	→	25 _ _	POT
_ _ 26	→	26 _ _	PUS
_ _ 27	→	27 _ _	MEND
_ _ 38	→	38 _ _	PT0
_ _ 39	→	39 _ _	PT1
_ _ 3A	→	3A _ _	PT2
_ _ 3B	→	3B _ _	PT3
_ _ 3C	→	3C _ _	PT4
_ _ 3D	→	3D _ _	PT5
_ _ 3E	→	3E _ _	PT6
_ _ 3F	→	3F _ _	PT7

Part 8: Common Reference Material

2.2.8 Parameters that need to be checked after parameter conversion

The following parameters may be required to be reviewed depending on your usage.

No.	Name	Initial value	Setting value	Description
PA04	Function selection A-1	2000h	0___h	Forced stop deceleration function selection To configure the same operation status as those for MR-J3-_T_, select "0___: Forced stop deceleration function disabled (EM1)".
PA06	Electronic gear numerator	-	-	For geared servo motors, the actual reduction ratio may differ before and after replacement. If they are different, consider the actual reduction ratio when setting.
PA07	Electronic gear denominator	-	-	
PA10	In-position range	-	-	When the value is over 4095 pulses with the in-position range unit selection ([Pr. PC24]) of MR-J3-_T_ set to "___1: Servo motor encoder unit", the value will be converted to 65535 pulses. To use the same in-position range as before, set "___0: Command input unit" and a value within the in-position range considering the electronic gear setting value.
PA09	Auto tuning response	-	-	Adjust the gain value again after the replacement.
PA19	Parameter write inhibit	00AAh	00ABh	The setting value after the conversion from MR-J3-_T_ is 00ABh. Set the value as required.
PD03 to PD28	I/O signal device selection	-	-	<ul style="list-style-type: none"> ▪ If not using a conversion cable, disable the I/O signal assignment conversion of the parameter converter function. The parameters related to I/O signal assignment are not converted, so review the wiring and settings as required. ▪ If using a conversion cable, enable the I/O signal assignment conversion of the parameter converter function. The parameters related to I/O signal assignment are converted in accordance with the control signal connection of the conversion cable. Contact Mitsubishi Electric System & Service Co., Ltd. for the specifications of the conversion cable.
Po15	MR-D01 analog monitor 1 offset	-	-	Not converted by the parameter converter function. Set the value as required.
Po16	MR-D01 analog monitor 2 offset	-	-	Not converted by the parameter converter function. Set the value as required.
Po21	MR-D01 override offset	-	-	Not converted by the parameter converter function. Set the value as required.
Po22	MR-D01 analog torque limit offset	-	-	Not converted by the parameter converter function. Set the value as required.
PT01	Command mode selection	0000h	1___h	RS-422 communication - Previous model equivalent selection For communication commands, the status display and reading/writing commands of input/output devices can be used with the same data numbers and bit assignment as in MR-J3-_T_. In this case, set "Enabled (equivalent to MR-J3-T)". When "Enabled" is set, MR Configurator2 is not available.
PT14	Backlash compensation	-	-	When the setting value of MR-J3-_T_ is over 4095 pulses, the value will be converted to 65535 pulses. The compensation amount must be readjusted for replacement.

Part 8: Common Reference Material

2.2.9 Conversion rules (MR-J3-_T_ (CC-Link communication operation) ⇒ MR-J4-_GF_)

The following table lists the parameter conversion rules from MR-J3-_T_ (CC-Link communication operation) to MR-J4-_GF_. Parameters not listed in the table use initial values.

Points
<ul style="list-style-type: none"> ● Before performing parameter conversion, set [Pr. PN03] of MR-J4-_GF_ to "___1" and set it to "I/O mode". ● Parameter conversion from MR-J3-_T_ to MR-J4-_GF_ is available on servo amplifiers with software version B0 or later. The software version can be checked in the system configuration display of MR Configurator2. ● The setting value for parameter writing prohibited after conversion from MR-J3-_T_ is set as follows. <ul style="list-style-type: none"> ▪ MR-J4-_GF_: [Pr. PA19] = "00ABh" ● Offset parameters cannot be converted. Review the settings as required. <ul style="list-style-type: none"> ▪ MR-J4-_GF_: [Pr. PC11]/[Pr. PC12] ● Since the servo parameters of MR-J3-_T_ and MR-J4-_GF_ are not fully compatible, some of the conversion rules specified below may not be applicable. Check the operation status on customer side and review the settings as required. ● The specifications of the following parameters differ between MR-J3-_T_ and MR-J4-_GF_. Check each servo amplifier instruction manual and review the settings. <ul style="list-style-type: none"> ▪ MR-J4-_GF_: [Pr. PA11]/[Pr. PA12] ● When using servo forced stop with input signal automatic ON selection, the setting method differs between MR-J3-_T_ and MR-J4-_GF_. Change the setting with the following parameter. <ul style="list-style-type: none"> ▪ MR-J4-_GF_: [Pr. PA04] ● Some input devices cannot be automatically turned on with input signal automatic ON selection of the following parameter. Input devices that cannot be turned on automatically should always be turned on with the link device. <ul style="list-style-type: none"> ▪ MR-J4-_GF_: [Pr. PD01] ● The parameters related to I/O signal assignment are not converted, so review the wiring and settings as required. Use a link device for I/O signals that cannot be assigned. <ul style="list-style-type: none"> ▪ MR-J4-_GF_: [Pr. PD03] to [Pr. PD05], [Pr. PD07] to [Pr. PD09] ● When replacing a geared servo motor, the reduction ratio may differ before and after the replacement. Check the servo motor specifications and review the electronic gear settings as required. <ul style="list-style-type: none"> ▪ MR-J4-_GF_: [Pr. PA06] to [Pr. PA07] ● The following parameters are converted according to the encoder resolution of the servo motor. <ul style="list-style-type: none"> ▪ MR-J4-_GF_: [Pr. PA10]/[Pr. PA15]/[Pr. PA21] / [Pr. PT14]/[Pr. PT40] <p>When "HG series" is selected for servo motor series selection, parameters are converted according to the encoder resolution of the HG motor.</p> <p>When "HF-_P/HC-_P/HA-_P series" is selected for servo motor series selection, parameters are converted according to the encoder resolution of the HF-_P/HC-_P/HA-_P servo motor.</p>

Part 8: Common Reference Material

MR-J3-_T_				MR-J4-_GF_			Conversion rule
No.	Name	Type	Model	No.	Type	Model	
PA01	Control mode	Hex	___X	PT01	Hex	___X	If the setting value of PA01 is 1 ___ (indexer method), the initial value will be used. If the setting value of PA01 is other than the above, it will be inherited.
			_X__	PA01	Hex	_X__	If "HG series" is selected for servo motor series selection, the setting value will not be inherited. When "HF-_P/HC-_P/HA-_P series" is selected for servo motor series selection, the conversion will be as follows. _0_ will be converted to _2_. For other than the above, _0_ will be used.
			X___			___X	0___ will be converted to ___0. 1___ will be converted to ___8. 2___ will be converted to ___B.
PA02	Regenerative option	Hex	__XX	PA02	Hex	__XX	The setting value will be inherited.
PA03	Absolute position detection system	Hex	___X	PA03	Hex	___X	The setting value will be inherited.
PA05	Feeding function selection	Hex	___X	PT03	Hex	___X	The setting value will be inherited.
PA06	Electronic gear numerator - Number of gear teeth on machine side	Dec	-	PA06	Dec	-	The setting value will be inherited.
PA07	Electronic gear denominator - Number of gear teeth on servo motor side	Dec	-	PA07	Dec	-	The setting value will be inherited.
PA08	Auto tuning mode	Hex	___X	PA08	Hex	___X	The setting value will be inherited.
PA09	Auto tuning response	Dec	-	PA09	Dec	-	4 will be added to the setting value.
PA10	In-position range	Dec	-	PA10	Dec	-	When "HG series" is selected for servo motor series selection, the conversion will be as follows. When the setting value of PA01 is 0 ___ (point table method) (1) If PC24 is ___0, the setting value will be inherited. (2) If PC24 is ___1, the setting value will be multiplied by 16. The above value will be clamped at 65535. If the setting value of PA01 is other than the above, it will be inherited. If "HF-_P/HC-_P/HA-_P series" is selected for servo motor series selection, the setting value will be inherited.
PA11	Forward rotation torque limit	Dec	-	PA11	Dec	-	The setting value is not inherited. MR-J3-_T_ and MR-J4-_GF_ have different parameter specifications, so check each instruction manual and review the setting values.
PA12	Reverse rotation torque limit	Dec	-	PA12	Dec	-	The setting value is not inherited. MR-J3-_T_ and MR-J4-_GF_ have different parameter specifications, so check each instruction manual and review the setting values.

Hex: Hexadecimal parameter, Dec: Decimal parameter

Part 8: Common Reference Material

MR-J3-_T_				MR-J4-_GF_			Conversion rule
No.	Name	Type	Model	No.	Type	Model	
PA14	Rotation direction selection	Dec	-	PA14	Dec	-	The setting value will be inherited.
PA15	Encoder output pulses	Dec	-	PA15	Dec	-	When "HG series" is selected for servo motor series selection, the conversion will be as follows. (1) When the setting value of PC19 is __ 1 __, the setting value will be multiplied by 16. (2) If the setting value of PC19 is other than __ 1 __, the setting value will be inherited. If "HF-_P/HC-_P/HA-_P series" is selected for servo motor series selection, the setting value will be inherited.
PA19	Parameter writing inhibit	Hex	XXXX	PA19	Hex	XXXX	The setting value will be 00AB.
PB01	Adaptive tuning mode (adaptive filter II)	Hex	___ X	PB01	Hex	___ X	The setting value will be inherited.
PB02	Vibration suppression control tuning mode (advanced vibration suppression control)	Hex	___ X	PB02	Hex	___ X	The setting value will be inherited.
PB04	Feed forward gain	Dec	-	PB04	Dec	-	The setting value will be inherited.
PB06	Load to motor inertia ratio	Dec	-	PB06	Dec	-	One decimal place will be added.
PB07	Model control gain	Dec	-	PB07	Dec	-	One decimal place will be added.
PB08	Position control gain	Dec	-	PB08	Dec	-	One decimal place will be added.
PB09	Speed control gain	Dec	-	PB09	Dec	-	The setting value will be inherited.
PB10	Speed integral compensation	Dec	-	PB10	Dec	-	The setting value will be inherited.
PB11	Speed differential compensation	Dec	-	PB11	Dec	-	The setting value will be inherited.
PB13	Machine resonance suppression filter 1	Dec	-	PB13	Dec	-	The setting value will be inherited.
PB14	Notch shape selection 1	Hex	__ X _	PB14	Hex	__ X _	The setting value will be inherited.
			_ X __			_ X __	The setting value will be inherited.
PB15	Machine resonance suppression filter 2	Dec	-	PB15	Dec	-	The setting value will be inherited.
PB16	Notch shape selection 2	Hex	___ X	PB16	Hex	___ X	The setting value will be inherited.
			__ X _			__ X _	The setting value will be inherited.
			_ X __			_ X __	The setting value will be inherited.
PB17	Automatic setting parameter	Hex	__ XX	PB17	Hex	__ XX	__ 01 will be converted to __ 00. If the setting value is other than the above, it will be inherited.
			_ X __			_ X __	The setting value will be inherited.
PB18	Low-pass filter setting	Dec	-	PB18	Dec	-	The setting value will be inherited.
PB19	Vibration suppression control - Vibration frequency	Dec	-	PB19	Dec	-	The setting value will be inherited.
PB20	Vibration suppression control - Resonance frequency	Dec	-	PB20	Dec	-	The setting value will be inherited.
PB23	Low-pass filter selection	Hex	__ X _	PB23	Hex	__ X _	The setting value will be inherited.
PB24	Slight vibration suppression control selection	Hex	___ X	PB24	Hex	___ X	The setting value will be inherited.
PB26	Gain switching selection	Hex	___ X	PB26	Hex	___ X	The setting value will be inherited.
			__ X _			__ X _	The setting value will be inherited.
PB27	Gain switching condition	Dec	-	PB27	Dec	-	The setting value will be inherited.
PB28	Gain switching time constant	Dec	-	PB28	Dec	-	The setting value will be inherited.
PB29	Load to motor inertia ratio after gain switching	Dec	-	PB29	Dec	-	One decimal place will be added.
PB30	Position loop gain after gain switching	Dec	-	PB30	Dec	-	One decimal place will be added.
PB31	Speed loop gain after gain switching	Dec	-	PB31	Dec	-	The setting value will be inherited.
PB32	Speed integral compensation after gain switching	Dec	-	PB32	Dec	-	The setting value will be inherited.

Hex: Hexadecimal parameter, Dec: Decimal parameter

Part 8: Common Reference Material

MR-J3-__T__				MR-J4-__GF__			Conversion rule
No.	Name	Type	Model	No.	Type	Model	
PB33	Vibration frequency for vibration suppression control after gain switching	Dec	-	PB33	Dec	-	The setting value will be inherited.
PB34	Resonance frequency for vibration suppression control after gain switching	Dec	-	PB34	Dec	-	The setting value will be inherited.
PC02	Home position return type	Hex	___X				<p>(1) When the setting value of PA01 is 0 ___ (point table method)</p> <p>(a) If the setting value of PC03 is __ _0, it will be converted as follows.</p> <p>___0 will be converted to -1.</p> <p>___1 will be converted to -2.</p> <p>___2 will be converted to 37.</p> <p>___3 will be converted to -4.</p> <p>___4 will be converted to -5.</p> <p>___5 will be converted to -6.</p> <p>___6 will be converted to -7.</p> <p>___7 will be converted to -8.</p> <p>___8 will be converted to -9.</p> <p>___9 will be converted to -10.</p> <p>___A will be converted to -11.</p> <p>For other than the above, it will be converted to the initial value.</p> <p>(b) If the setting value of PC03 is __ _1, it will be converted as follows.</p> <p>___0 will be converted to -33.</p> <p>___1 will be converted to -34.</p> <p>___2 will be converted to 37.</p> <p>___3 will be converted to -36.</p> <p>___4 will be converted to -5.</p> <p>___5 will be converted to -38.</p> <p>___6 will be converted to -39.</p> <p>___7 will be converted to -40.</p> <p>___8 will be converted to -41.</p> <p>___9 will be converted to -42.</p> <p>___A will be converted to -43.</p> <p>For other than the above, it will be converted to the initial value.</p> <p>(2) When the setting value of PA01 is 1 ___ (indexer method)</p> <p>(a) If the setting value of PC03 is __ _0, it will be converted as follows.</p> <p>___C will be converted to -1.</p> <p>___D will be converted to -3.</p> <p>For other than the above, it will be converted to 37 (initial value).</p> <p>(b) When the setting value of PC03 is ___ _1</p> <p>___C will be converted to -33.</p> <p>___D will be converted to -3.</p> <p>For other than the above, it will be converted to 37 (initial value).</p> <p>If the setting value of PA01 is other than the above, it will be converted to the initial value.</p>
PC03	Homing direction	Hex	___X	PT45	Dec	-	
PC04	Homing speed	Dec	-	PT05	Dec	-	Two decimal places will be added.
PC05	Creep speed	Dec	-	PT06	Dec	-	Two decimal places will be added.
PC06	Home position shift distance	Dec	-	PT07	Dec	-	The setting value will be inherited.

Hex: Hexadecimal parameter, Dec: Decimal parameter

Part 8: Common Reference Material

MR-J3-_T_				MR-J4-_GF_			Conversion rule
No.	Name	Type	Model	No.	Type	Model	
PC07	Homing position data	Dec	-	PT08 PT47	Dec	-	If PC07 is 0 or more, it will be converted as follows. <ul style="list-style-type: none"> For PT08, the setting value will be inherited. For PT47, the setting value will be converted to 0. If PC07 is less than 0, it will be converted as follows. <ul style="list-style-type: none"> For PT08, 65536 will be added to the setting value. For PT47, it will be converted to -1.
PC08	Travel distance after proximity dog	Dec	-	PT09	Dec	-	The setting value will be inherited.
PC09	Stopper type home position return - Stopper time	Dec	-	PT10	Dec	-	The setting value will be inherited.
PC10	Stopper type home position return - Torque limit value	Dec	-	PT11	Dec	-	The setting value will be inherited.
PC11	Rough match output range	Dec	-	PT12	Dec	-	The setting value will be inherited.
PC12	JOG speed	Dec	-	PT65	Dec	-	The setting value will be inherited.
PC13	S-pattern acceleration/deceleration time constants	Dec	-	PT51	Dec	-	The setting value will be inherited.
PC14	Backlash compensation	Dec	-	PT14	Dec	-	When "HG series" is selected for servo motor series selection, the setting value will be multiplied by 16 before being converted. This value will be clamped at 65535. If "HF-_P/HC-_P/HA-_P series" is selected for servo motor series selection, the setting value will be inherited.
PC16	Electromagnetic brake sequence output	Dec	-	PC02	Dec	-	The setting value will be inherited.
PC17	Zero speed	Dec	-	PC07	Dec	-	The setting value will be inherited.
PC18	Alarm history clear	Hex	___X	PC21	Hex	___X	The setting value will be inherited.
PC19	Encoder output pulses selection	Hex	___X	PC03	Hex	___X	The setting value will be inherited. __2__ will be converted to __0__. If the setting value is other than the above, it will be inherited.
			__X_			__X_	
PC22	Function selection C-1	Hex	X___	PC04	Hex	X___	The setting value will be inherited.
PC24	Function selection C-3	Hex	__X	PC06	Hex	__X	The setting value will be inherited.
PC26	Function selection C-5	Hex	__X	PC19	Hex	__X	The setting value will be inherited.
PC28	Function selection C-7	Hex	___X	PT26	Hex	___X	The setting value will be inherited.
			__X_			__X_	
PC30	Remote register-based position/speed specifying method selection	Hex	___X	PT62	Hex	___X	The setting value will be inherited.
			__X_			__X_	
			_X__			_X__	
PC31	Software limit +	Dec	-	PT15	Dec	-	The value of PC32 x 1000 + PC31 will be converted from signed decimal to hexadecimal. After the value is converted to hexadecimal, the lower 4 digits are set.
PC32	Software limit +	Dec	-	PT16	Dec	-	The value of PC32 x 1000 + PC31 will be converted from signed decimal to hexadecimal. After the value is converted to hexadecimal, the upper 4 digits are set.
PC33	Software limit -	Dec	-	PT17	Dec	-	The value of PC34 x 1000 + PC33 will be converted from signed decimal to hexadecimal. After the value is converted to hexadecimal, the lower 4 digits are set.

Hex: Hexadecimal parameter, Dec: Decimal parameter

Part 8: Common Reference Material

MR-J3-_T_				MR-J4-_GF_			Conversion rule
No.	Name	Type	Model	No.	Type	Model	
PC34	Software limit -	Dec	-	PT18	Dec	-	The value of PC34 x 1000 + PC33 will be converted from signed decimal to hexadecimal. After the value is converted to hexadecimal, the upper 4 digits are set.
PC35	Internal torque limit 2	Dec	-	PC77	Dec	-	The setting value is not inherited. MR-J3-_T_ and MR-J4-_GF_ have different parameter specifications, so check each instruction manual and review the setting values.
PC37	Position range output address +	Dec	-	PT19	Dec	-	The value of PC38 x 1000 + PC37 will be converted from signed decimal to hexadecimal. After the value is converted to hexadecimal, the lower 4 digits are set.
PC38	Position range output address +	Dec	-	PT20	Dec	-	The value of PC38 x 1000 + PC37 will be converted from signed decimal to hexadecimal. After the value is converted to hexadecimal, the upper 4 digits are set.
PC39	Position range output address -	Dec	-	PT21	Dec	-	The value of PC40 x 1000 + PC39 will be converted from signed decimal to hexadecimal. After the value is converted to hexadecimal, the lower 4 digits are set.
PC40	Position range output address -	Dec	-	PT22	Dec	-	The value of PC40 x 1000 + PC39 will be converted from signed decimal to hexadecimal. After the value is converted to hexadecimal, the upper 4 digits are set.
PC45	Function selection C-9	Hex	__X	PT27	Hex	__X_	The setting value will be inherited.
PC46	Number of stations/rotation for indexer positioning operation	Hex	X X X X	PT28	Dec	-	Unsigned hexadecimal will be converted to decimal.
PC47	Station home position shift distance for indexer positioning operation	Hex	X X X X	PT40	Dec	-	When "HG series" is selected for servo motor series selection, the conversion will be as follows. Signed hexadecimal will be converted to decimal. If the value is within -2000 to 2000 after conversion to decimal, it will be multiplied by 16 before being set. If the setting value after conversion is less than -2000 or more than 2000, it will not be inherited. When "HF-_P/HC-_P/HA-_P series" is selected for servo motor series selection, the conversion will be as follows. Signed hexadecimal will be converted to decimal. If the setting value is within -2000 to 2000 after conversion to decimal, it will be inherited. If the setting value after conversion is less than -2000 or more than 2000, it will not be inherited.
PC50	Function selection C-A	Hex	__X	PT62	Hex	X__	The setting value will be inherited.

Hex: Hexadecimal parameter, Dec: Decimal parameter

Part 8: Common Reference Material

MR-J3-_T_				MR-J4-_GF_			Conversion rule
No.	Name	Type	Model	No.	Type	Model	
PD01	Input signal automatic ON selection 1	Hex	_X__	PD01	Hex	_X__	(Bin) _0__ will be converted to (Bin) _0__. (Bin) _1__ will be converted to (Bin) _1__ (LSP automatic on) (Bin) 0___ will be converted to (Bin) 0___. (Bin) 1___ will be converted to (Bin) 1___ (LSN automatic on)
			X___	PA04	Hex	X___	(Bin) ___0 will be converted to _0_ _ (Bin) ___1 will be converted to _1_ _ (EM2 disabled)
PD16	Input polarity selection	Hex	___X	PT29	Hex	___X	When the setting value of PA01 is 1_ _ (indexer method) ___0 will be converted to (Bin) ___1. (Dog detection with off) ___1 will be converted to (Bin) ___0. (Dog detection with on) If the setting value of PA01 is other than the above, it will be inherited.
PD19	Input filter setting	Hex	___X	PD29	Hex	___X	The setting value will be inherited.
PD20	Function selection D-1	Hex	___X	PD12	Hex	___X	The setting value will be inherited.
			_X__			_X__	The setting value will be inherited.
PD22	Function selection D-3	Hex	___X	PD42	Hex	___X	___0 will be converted to ___2. ___1 will be converted to ___0. ___2 will be converted to ___1.
PD24	Function selection D-5	Hex	__X_	PD14	Hex	__X_	The setting value will be inherited.
PD25	CC-Link/CC-Link IE communication error (A8D) detection time	Hex	X X X X	PN02	Dec	-	Unsigned hexadecimal will be converted to decimal. If the value exceeds 1000, it will be clamped at 1000.
PD26	Torque limit delay time for indexer positioning operation	Hex	X X X X	PT39	Dec	-	Unsigned hexadecimal will be converted to decimal. The above value will be clamped at 1000.
-	Function selection A-3 (Note)	-	-	PA21	Hex	X___	When "HG series" is selected for servo motor series selection, the conversion will be as follows. ▪ When the setting value of PA01 is 0 ___ (point table method) It will be converted to 2 ___. ▪ If the setting value of PA01 is other than the above, it will be converted to the initial value. When " HF-_P/HC-_P/HA-_P series " is selected for servo motor series selection, the setting value will be converted to 0 ___.

Hex: Hexadecimal parameter, Dec: Decimal parameter

Note. This is the parameter name on MR-J4-_GF_.

Part 8: Common Reference Material

2.2.10 Parameters requiring check after parameter conversion

The following parameters may need to be reviewed depending on how the customer uses them.

No.	Name	Initial value	Setting value	Detailed explanation
PA04	Function selection A-1	2000h	_ 0 _ _ h	Servo forced stop selection When "Forced stop (EMG)" is set to "Automatic ON" in [Pr. PD01] on MR-J3-_T_, it is set to "1: Disabled (the forced stop input EM2 and EM1 are not used)" on MR-J4-_GF_. Review the settings as required.
			0 _ _ _ h	Forced stop deceleration function selection To make the operation status similar to that of MR-J3-_T_, set this to "0 _ _ _": Forced stop deceleration function disabled (EM1 is used)".
PA06	Electronic gear numerator	-	-	For geared servo motors, the actual reduction ratio may differ before and after replacement. If they are different, consider the actual reduction ratio when setting.
PA07	Electronic gear denominator	-	-	
PA09	Auto tuning response	-	-	
PA10	In-position range	-	-	<For point table positioning operation> If " _ _ _ 1: Servo motor detector unit" is selected for "In-position range unit selection" in [Pr. PC24] of MR-J3-_T_ and the value exceeds 4095 [pulse], the value will be converted to 65535 [pulse]. If using the same in-position range as before, set [Pr. PC24] of MR-J3-_T_ to " _ _ _ 0: Command input unit" and set the in-position range value considering the setting value of the electronic gear. <For indexer positioning operation> It will be converted to the command input unit regardless of the setting value of [Pr. PC24] in MR-J3-_T_. If the setting value is out of the parameter range, it will be converted to 65535 [pulse]. Check the device for any problems.
PA11	Forward rotation torque limit	-	-	It will not be converted by the parameter converter function. MR-J3-_T_ and MR-J4-_GF_ have different parameter specifications, so check each servo amplifier instruction manual and review the setting values.
PA12	Reverse rotation torque limit	-	-	
PC11	Analog monitor 1 offset	-	-	It will not be converted by the parameter converter function. Perform the settings as required.
PC12	Analog monitor 2 offset	-	-	
PA19	Parameter writing inhibit	00AAh	00ABh	After conversion from MR-J3-_T_, it will be set to 00ABh. Perform the settings as required.
PC29	Function selection C-B	0000h	-	Speed monitor unit selection It will not be converted by the parameter converter function. MR-J3-_T_ and MR-J4-_GF_ have different parameter specifications, so set " _ _ 0_: r/min unit" or " _ _ 1_: 0.01 r/min unit" as required.
PC77	Internal torque limit 2	-	-	It will not be converted by the parameter converter function. MR-J3-_T_ and MR-J4-_GF_ have different parameter specifications, so check each servo amplifier instruction manual and review the setting values.
PD01	Input signal automatic ON selection 1	-	-	Some input devices cannot be converted by the parameter converter function. Input devices that cannot be turned on automatically should always be turned on with the link device.
PD03 to PD05 PD07 to PD09	Input device selection 1 to 3 Output device selection 1 to 3	-	-	It will not be converted by the parameter converter function. Review the settings as required. Use a link device for I/O signals that cannot be assigned.

Part 8: Common Reference Material

No.	Name	Initial value	Setting value	Detailed explanation
PD41	Function selection D-4	0000h	-	<p>Sensor input method selection</p> <p>It will not be converted by the parameter converter function.</p> <p>On MR-J4-_GF_, the proximity dog and stroke limit input method cannot be selected individually.</p> <p>Set "0 ___": Input from servo amplifier (LSP/LSN/DOG)" or "1 ___": Input from controller (FLS/RLS/DOG)" as required.</p>
PT14	Backlash compensation	-	-	<p>If [Pr. PC24] of MR-J3-_T_ exceeds 4095 [pulse], it will be converted to 65535 [pulse].</p> <p>When replacing, it is necessary to adjust the compensation again.</p>

Part 8: Common Reference Material

2.3 MR-J3-_B_ and MR-J3W-_B_ Parameter Diversion Procedure

The parameter converter functions of GX Works2 and MT Developer2 convert the servo parameters of MR-J3-_B_ and MR-J3W-_B_ to those of MR-J4-_B_ /MR-J4W2-_B_ and when the controller is changed.
(GX Works2: 1.84N or later, MT Developer2: 1.41T or later)

POINT

- Parameters common to MR-J3-_B_, MR-J3W-_B_, MR-J4-_B_ and MR-J4W2-_B_ are the conversion targets.
The initial value of MR-J4-_B_ and MR-J4W2-_B_ is set for additional parameters of MR-J4-_B_ and MR-J4W2-_B_.

(Target model)

- Positioning module QD75MH to Simple Motion module QD77MS/LD77MS
- Motion controller Q17nHCPU/Q17nDCPU/Q170MCPU to Q17nDSCPU/Q170MSCPU(-S1)

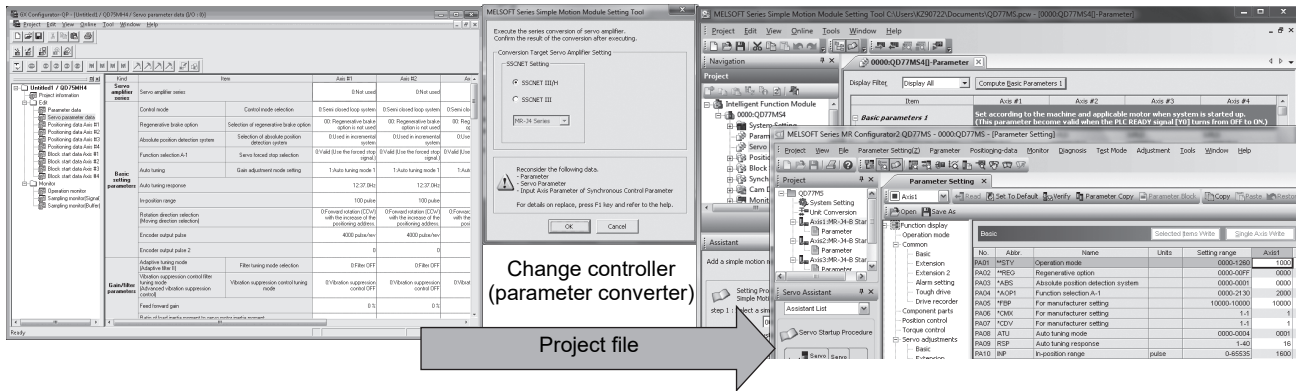

GX Configurator-QP
SW3RNC-GSV
SW6RNC-GSV

GX Works2 (Simple Motion module setting tool)
MT Developer2

Change MR-J3-_B_ /MR-J3W-_B_ to MR-J4-_B_ /MR-J4W2-_B_

Part 8: Common Reference Material

2.3.1 Changing QD75MH to QD77MS/LD77MS

- (1) Start GX Works2 and create a project.
- (2) Right-click [Intelligent Function Module] in the Navigation window and select [New Module] to add the simple motion module QD77MS/LD77MS.

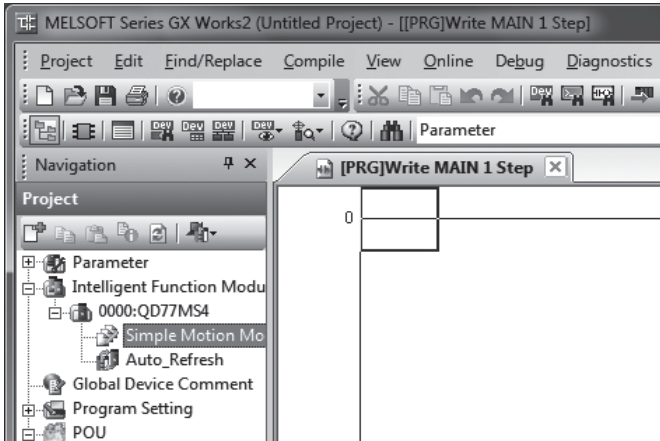

- (3) Double-click [Simple Motion Module Setting] of the added simple motion module to start the simple motion module setting tool.
- (4) Read the GX Configurator-QP data.
Click [Project] - [Import Other Format data] from the menu to display the screen for reading GX Configurator-QP data. Specify and read QD75MH data.

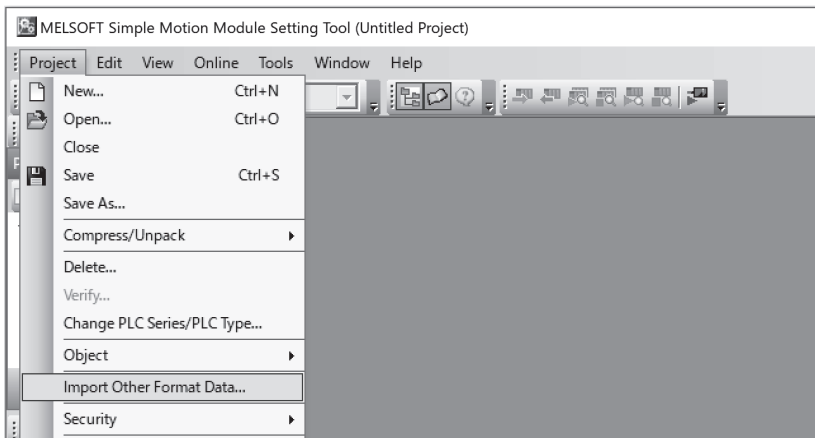

When using QD75MH data made on GX Works2, save the QD75 data as GX Configurator-QP data on GX Works2 and perform the above operation.

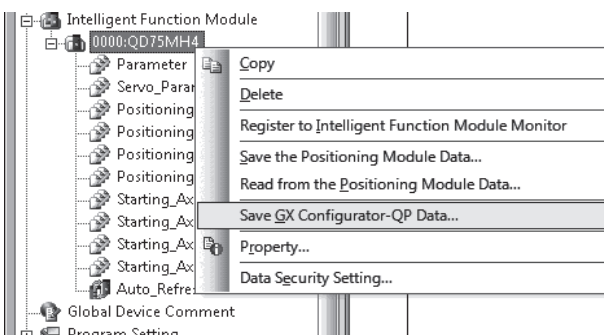

Part 8: Common Reference Material

(5) Specify the target module.

Specify the model and the head XY address of the target module and then click the [OK] button.

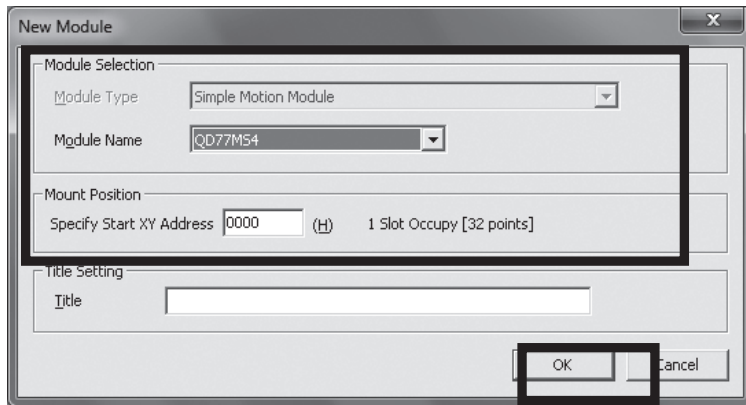

(6) Execute servo parameter conversion.

Select "Conversion Target Servo Amplifier Setting" and "Conversion Target Servo Motor Series Setting", and click the [OK] button.

The servo parameters are converted as follows in accordance with the SSCNET settings.

When "SSCNET III/H" is selected: MR-J3-_B_ is converted to MR-J4-_B_, and MR-J3W-_B_ is converted to MR-J4W2-_B_.

When "SSCNET III" is selected: MR-J3-_B_ and MR-J3W-_B_ data are used without conversion.

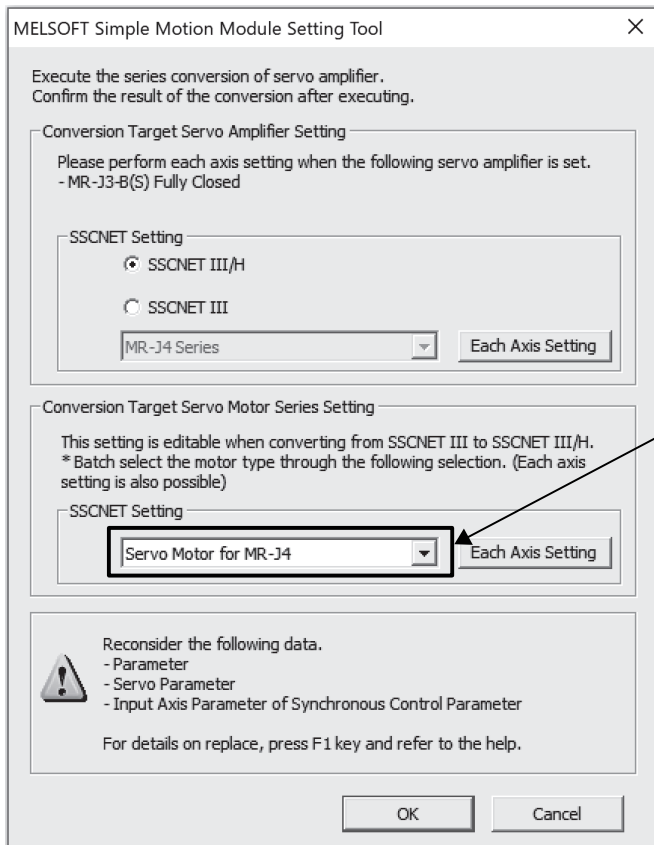

"Conversion Target Servo Motor Series Setting" can be used with software version 1.590Q or later of GX Works2.

Part 8: Common Reference Material

2.3.2 Changing Q17nHCPU/Q17nDCPU/Q170MCPUs to Q17nDSCPU/Q170MSCPU(-S1)

POINT

- "Conversion Target Servo Motor Series Setting" is available in MT Developer2 with software version 1.150G or later.

(1) Start MT Developer2.

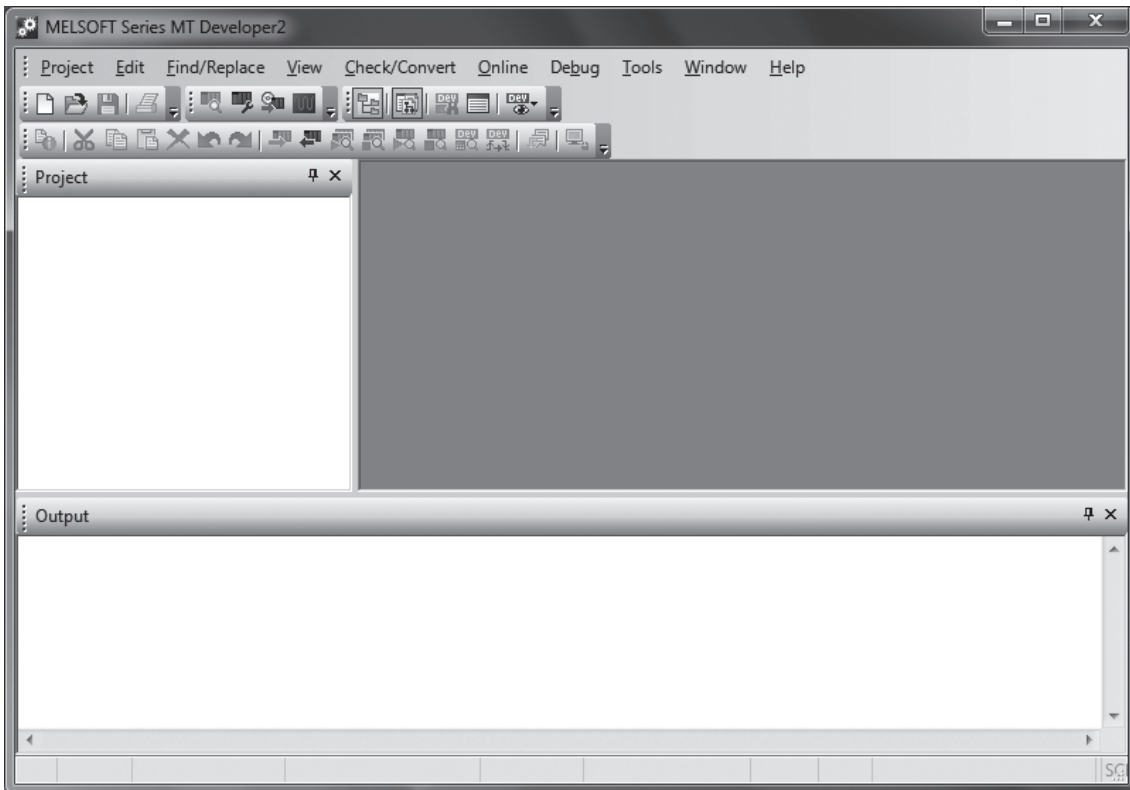

(2) Select the source project.

Click [Project] - [Divert File] - [Diversion of Other Format Project] from the menu to display the Diversion of Other Format Project window. Click the [Browse] button and select a source project.

To divert an MT Developer2 project, click [Project] - [Divert File] - [Utilize MT Developer file format Project] from the menu.

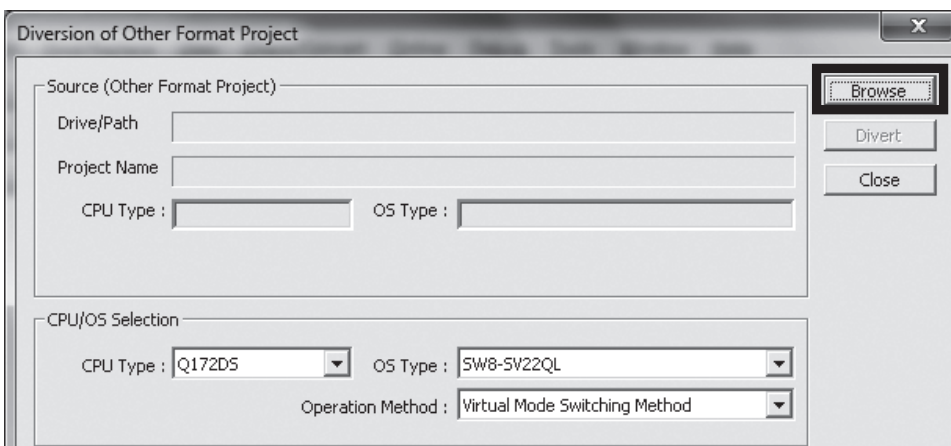

Part 8: Common Reference Material

(3) Execute file diversion.

Select the CPU type, OS type, and Operation method in the CPU/OS selection, and click the [Diversion] button.

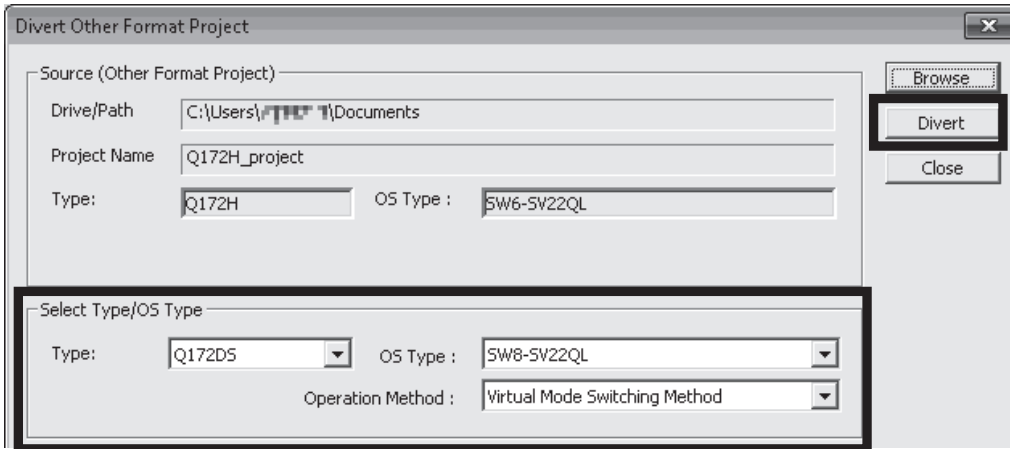

(4) Execute servo parameter conversion.

"Conversion target servo amplifier setting" and "conversion target servo motor series setting" and click the [OK] button. (The figure shows an example of two SSCNET lines.)

The servo parameters are converted as follows depending on the target servo amplifier setting.

When "SSCNET III/H" is selected, MR-J3-_B_ is converted to MR-J4-_B_, MR-J3W-_B_ is converted to MR-J4W2-_B_

When "SSCNET III" is selected: Utilize the MR-J3-_B_ and MR-J3W-_B_ data without conversion.

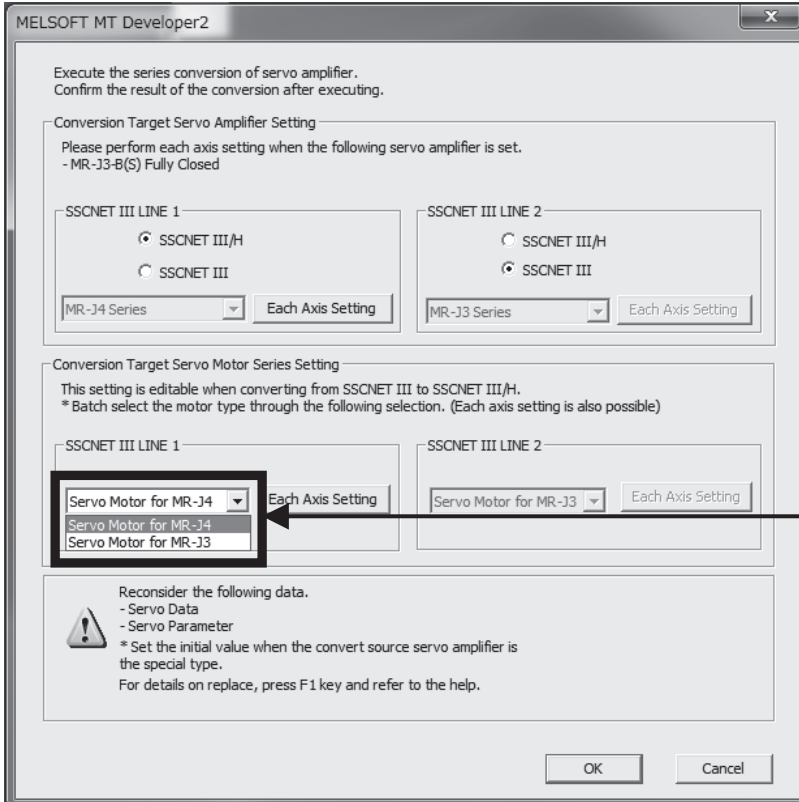

"Conversion Target Servo Motor Series Setting" is available in MT Developer2 with software version 1.150G or later.

Part 8: Common Reference Material

2.3.3 Conversion rules (MR-J3-_B_ and MR-J3W-_B => MR-J4-_B_ and MR-J4W2-_B)

- (1) Conversion rules (MR-J3-_B_ (standard) and MR-J3W-_B (standard) => MR-J4-_B_ (standard) and MR-J4W2-_B (standard))

The following table shows the servo parameter conversion rules from MR-J3-_B_ (standard) and MR-J3W-_B (standard) to MR-J4-_B_ (standard) and MR-J4W2-_B (standard).

Servo parameters not specified in the following table will be set to the initial values.

POINT
<ul style="list-style-type: none"> ● Because the servo parameters of MR-J3-_B_/MR-J3W-_B and those of MR-J4-_B_/MR-J4W2-_B are not completely interchangeable, the conversion rules may not be applied. Check the operations and review the settings as necessary. ● The parameter writing inhibit after parameter conversion is the initial value (the following setting value). <ul style="list-style-type: none"> ▪ MR-J4-_B_ and MR-J3W-_B: [Pr. PA19 Parameter writing inhibit] = "00ABh" ● Various offset parameters cannot be converted. Change the settings as necessary. <ul style="list-style-type: none"> ▪ MR-J4-_B_ and MR-J3W-_B: [Pr. PC11]/[Pr. PC12] ● When the geared servo motor is replaced, the reduction ratio may differ before and after the replacement. Check the specifications of the servo motor and review the electronic gear settings as necessary. For the electronic gear settings, refer to the controller instruction manual. ● The following parameters will be converted to values according to the encoder resolution of the servo motor. <ul style="list-style-type: none"> ▪ MR-J4-_B_ : [Pr. PA10]/[Pr. PA15]/[Pr. PC13]/[Pr. PC14]/[Pr. PE05]/[Pr. PE35] <p>When "Servo Motor for MR-J4" is selected in "Conversion Target Servo Motor Series Setting" on the MT Developer2 screen as shown in section 2.3.2 (4), the parameters will be converted to values according to the encoder resolution of the HG motor.</p> <p>When "Servo Motor for MR-J3" is selected in "Conversion Target Servo Motor Series Setting", the parameters will be converted to values according to the encoder resolution of the HF-_P_/HC-_P_/HA-_P servo motor.</p>
<div style="border: 1px solid gray; padding: 10px; margin-bottom: 10px;"> <p style="margin: 0;">Conversion Target Servo Motor Series Setting</p> <p style="margin: 0; font-size: small;">This setting is editable when converting from SSCNET III to SSCNET III/H. * Batch select the motor type through the following selection. (Each axis setting is also possible)</p> <div style="display: flex; justify-content: space-between; margin-top: 10px;"> <div style="width: 45%;"> <p style="margin: 0; font-size: small;">SSCNET III LINE 1</p> <div style="border: 1px solid gray; padding: 5px; margin-top: 5px;"> <div style="display: flex; justify-content: space-between; align-items: center;"> Servo Motor for MR-J4 Each Axis Setting </div> <div style="border: 1px solid gray; padding: 2px; margin-top: 2px;"> Servo Motor for MR-J4 Servo Motor for MR-J3 </div> </div> </div> <div style="width: 45%;"> <p style="margin: 0; font-size: small;">SSCNET III LINE 2</p> <div style="border: 1px solid gray; padding: 5px; margin-top: 5px;"> <div style="display: flex; justify-content: space-between; align-items: center;"> Servo Motor for MR-J3 Each Axis Setting </div> </div> </div> </div> </div>
<p>"Conversion Target Servo Motor Series Setting" is available in MT Developer2 with software version 1.150G or later.</p> <ul style="list-style-type: none"> ● Some parameters are not supported depending on the software version of the servo amplifier. Refer to section 2.3.4 for details. ● Refer to section 2.3.4 (2) for differences between the servo parameters of MR-J3-_B_ and MR-J3W-_B.

Part 8: Common Reference Material

MR-J3-_B_/MR-J3W-_B				MR-J4-_B_/MR-J4W2-_B			Conversion rules
No.	Name	Type	Target	No.	Type	Target	
PA01	Control mode	Hex	_X_	PA01	Hex	_X_	When "Servo Motor for MR-J4" is selected in "Conversion Target Servo Motor Series Setting" on the MT Developer2 screen, the setting value will not be maintained. When "Servo Motor for MR-J3" is selected in "Conversion Target Servo Motor Series Setting" on the MT Developer2 screen, the setting value will be converted as follows: _0_ will be changed to _2_. _4_ will be changed to _2_. The setting value other than the above will be _0_. Selecting "Servo Motor for MR-J4" or "Servo Motor for MR-J3" for conversion is available in MT Developer2 with software version 1.150G or later.
PA02	Regenerative option	Hex	__XX	PA02	Hex	__XX	The setting value will be maintained.
PA03	Absolute position detection system	Hex	___X	PA03	Hex	___X	The setting value will be maintained.
PA04	Function selection A-1	Hex	_X_	PA04	Hex	_X_	The setting value will be maintained.
PA08	Auto tuning mode	Hex	___X	PA08	Hex	___X	The setting value will be maintained.
PA09	Auto tuning response	Dec	-	PA09	Dec	-	The value 4 is added to the setting value.
PA10	In-position range	Dec	-	PA10	Dec	-	When "Servo Motor for MR-J4" is selected in "Conversion Target Servo Motor Series Setting" on the MT Developer2 screen, the setting value will be converted as follows: The setting value will increase by 16 times when it is 4095 or smaller. The setting value other than the above will be 65535. When "Servo Motor for MR-J4" is selected in "Conversion Target Servo Motor Series Setting" on the MT Developer2 screen, the setting value will be maintained. Selecting "Servo Motor for MR-J4" or "Servo Motor for MR-J3" for conversion is available in MT Developer2 with software version 1.150G or later.
PA14	Rotation direction selection	Dec	-	PA14	Dec	-	The setting value will be maintained.

Part 8: Common Reference Material

MR-J3-_B_/MR-J3W-_B				MR-J4-_B_/MR-J4W2-_B			Conversion rules
No.	Name	Type	Target	No.	Type	Target	
PA15	Encoder output pulses	Dec	-	PA15	Dec	-	<p>When "Servo Motor for MR-J4" is selected in "Conversion Target Servo Motor Series Setting" on the MT Developer2 screen, the setting value will be converted as follows: When the setting value of PC03 is __1__, the setting value of PA15 is increased by 16 times. However, when the value is 65535 or larger, the setting value will be 65535.</p> <p>When the setting value of PC03 is other than __1__, it will be maintained.</p> <p>When "Servo Motor for MR-J4" is selected in "Conversion Target Servo Motor Series Setting" on the MT Developer2 screen, the setting value will be maintained. Selecting "Servo Motor for MR-J4" or "Servo Motor for MR-J3" for conversion is available in MT Developer2 with software version 1.150G or later.</p>
PB01	Adaptive tuning mode (Adaptive filter II)	Hex	___X	PB01	Hex	___X	The setting value will be maintained.
PB02	Vibration suppression control tuning mode (advanced vibration suppression control)	Hex	___X	PB02	Hex	___X	The setting value will be maintained.
PB04	Feed forward gain	Dec	-	PB04	Dec	-	The setting value will be maintained.
PB06	Ratio of load inertia moment to servo motor inertia moment	Dec	-	PB06	Dec	-	One decimal place will be added.
PB07	Model loop gain	Dec	-	PB07	Dec	-	One decimal place will be added.
PB08	Position loop gain	Dec	-	PB08	Dec	-	One decimal place will be added.
PB09	Speed loop gain	Dec	-	PB09	Dec	-	The setting value will be maintained.
PB10	Speed integral compensation	Dec	-	PB10	Dec	-	The setting value will be maintained.
PB11	Speed differential compensation	Dec	-	PB11	Dec	-	The setting value will be maintained.
PB12	Overshoot amount compensation	Dec	-	PB12	Dec	-	The setting value will be maintained.
PB13	Machine resonance suppression filter 1	Dec	-	PB13	Dec	-	The setting value will be maintained.
PB14	Notch shape selection 1	Hex	_XX_	PB14	Hex	_XX_	The setting value will be maintained.
PB15	Machine resonance suppression filter 2	Dec	-	PB15	Dec	-	The setting value will be maintained.
PB16	Notch shape selection 2	Hex	_XXX	PB16	Hex	_XXX	The setting value will be maintained.
PB17	Automatic setting parameter	Hex	__XX _X__	PB17	Hex	__XX _X__	__01 will be changed to __00. Otherwise, the setting value will be maintained.
PB18	Low-pass filter setting	Dec	-	PB18	Dec	-	The setting value will be maintained.
PB19	Vibration suppression control vibration frequency setting	Dec	-	PB19	Dec	-	The setting value will be maintained.
PB20	Vibration suppression control resonance frequency setting	Dec	-	PB20	Dec	-	The setting value will be maintained.
PB23	Low-pass filter selection	Hex	__X_	PB23	Hex	__X_	The setting value will be maintained.
PB24	Slight vibration suppression control selection	Hex	__XX	PB24	Hex	__XX	The setting value will be maintained.
PB26	Gain changing selection	Hex	__XX	PB26	Hex	__XX	The setting value will be maintained.
PB27	Gain changing condition	Dec	-	PB27	Dec	-	The setting value will be maintained.
PB28	Gain changing time constant	Dec	-	PB28	Dec	-	The setting value will be maintained.
PB29	Gain changing ratio of load inertia moment to servo motor inertia moment	Dec	-	PB29	Dec	-	One decimal place will be added.

Part 8: Common Reference Material

MR-J3-_B_/MR-J3W-_B				MR-J4-_B_/MR-J4W2-_B			Conversion rules
No.	Name	Type	Target	No.	Type	Target	
PB30	Gain changing position loop gain	Dec	-	PB30	Dec	-	One decimal place will be added.
PB31	Gain changing speed loop gain	Dec	-	PB31	Dec	-	The setting value will be maintained.
PB32	Gain changing speed integral compensation	Dec	-	PB32	Dec	-	The setting value will be maintained.
PB33	Gain changing vibration suppression control vibration frequency setting	Dec	-	PB33	Dec	-	The setting value will be maintained.
PB34	Gain changing vibration suppression control resonance frequency setting	Dec	-	PB34	Dec	-	The setting value will be maintained.
PB45	Vibration suppression control filter 2	Hex	_XXX	PB45	Hex	_XXX	The setting value will be maintained.
PC01	Error excessive alarm level	Dec	-	PC01	Dec	-	The setting value will be maintained.
PC02	Electromagnetic brake sequence output	Dec	-	PC02	Dec	-	The setting value will be maintained.
PC03	Encoder output pulses selection	Hex	__XX	PC03	Hex	__XX	The setting value will be maintained.
PC04	Function selection C-1	Hex	X__	PC04	Hex	X__	The setting value will be maintained.
PC05	Function selection C-2	Hex	__X	PC05	Hex	__X	The setting value will be maintained.
PC06	Function selection C-3	Hex	X__	PC06	Hex	X__	The setting value will be maintained.
PC07	Zero speed	Dec	-	PC07	Dec	-	The setting value will be maintained.
PC09	Analog monitor 1 output	Hex	__X	PC09	Hex	__X	The setting value will be maintained.
PC10	Analog monitor 2 output	Hex	__X	PC10	Hex	__X	The setting value will be maintained.
PC13	Analog monitor feedback position output standard data Low	Dec	-	PC13	Dec	-	When "Servo Motor for MR-J4" is selected in "Conversion Target Servo Motor Series Setting" on the MT Developer2 screen, the setting value will be converted as follows: The lower four digits of the calculation result of $PC14 \times 160000 + PC13 \times 16$ will be set. However, when the calculation result is -99999999 or smaller, -9999 will be set. When the calculation result is 99999999 or larger, 9999 will be set. When "Servo Motor for MR-J3" is selected in "Conversion Target Servo Motor Series Setting" on the MT Developer2 screen, the setting value will be maintained. Selecting "Servo Motor for MR-J4" or "Servo Motor for MR-J3" for conversion is available in MT Developer2 with software version 1.150G or later.

Part 8: Common Reference Material

MR-J3-_B_/MR-J3W-_B				MR-J4-_B_/MR-J4W2-_B			Conversion rules
No.	Name	Type	Target	No.	Type	Target	
PC14	Analog monitor feedback position output standard data High	Dec	-	PC14	Dec	-	When "Servo Motor for MR-J4" is selected in "Conversion Target Servo Motor Series Setting" on the MT Developer2 screen, the setting value will be converted as follows: The integral value of the calculation result of $(PC14 \times 160000 + PC13 \times 16) \div 10000$ will be set. However, when the calculation result is -9999 or smaller, -9999 will be set. When the calculation result is 9999 or larger, 9999 will be set. When "Servo Motor for MR-J3" is selected in "Conversion Target Servo Motor Series Setting" on the MT Developer2 screen, the setting value will be maintained. Selecting "Servo Motor for MR-J4" or "Servo Motor for MR-J3" for conversion is available in MT Developer2 with software version 1.150G or later.
PC17	Function selection C-4	Hex	___X	PC17	Hex	___X	The setting value will be maintained.
PC20	Function selection C-7	Hex	___X	PC20	Hex	___X	The setting value will be maintained.
PC21	Alarm history clear	Hex	___X	PC21	Hex	___X	The setting value will be maintained.
PD07	Output signal device selection 1 (CN3-13)	Hex	__XX	PD07	Hex	__XX	__0B will be changed to __05. Otherwise, the setting value will be maintained.
PD08	Output signal device selection 2 (CN3-9)	Hex	__XX	PD08	Hex	__XX	__0B will be changed to __04. Otherwise, the setting value will be maintained.
PD09	Output signal device selection 3 (CN3-15)	Hex	__XX	PD09	Hex	__XX	__0B will be changed to __03. Otherwise, the setting value will be maintained.
PD14	Function selection D-3	Hex	__X_	PD14	Hex	__X_	The setting value will be maintained.
PD15	Driver communication setting	Hex	__XX	PD15	Hex	__XX	The setting value will be maintained.
PD16	Driver communication setting - Master - Transmit data selection 1	Hex	__XX	PD16	Hex	__XX	The setting value will be maintained.
PD17	Driver communication setting - Master - Transmit data selection 2	Hex	__XX	PD17	Hex	__XX	The setting value will be maintained.
PD20	Driver communication setting - Slave - Master axis No. selection 1	Dec	-	PD20	Dec	-	The setting value will be maintained.
PD30	Master-slave operation - Torque command coefficient on slave	Hex	XXXX	PD30	Dec	-	A hexadecimal value without sign will be converted into a decimal value. When the setting value is larger than 500, it will be 500.
PD31	Master-slave operation - Speed limit coefficient on slave	Hex	XXXX	PD31	Dec	-	A hexadecimal value without sign will be converted into a decimal value. When the setting value is larger than 500, it will be 500.
PD32	Master-slave operation - Speed limit adjusted value on slave	Hex	XXXX	PD32	Dec	-	A hexadecimal value without sign will be converted into a decimal value.

Hex: hexadecimal parameter; Dec: decimal parameter

Part 8: Common Reference Material

2.3.4 Parameters that need to be checked after parameter conversion

(1) MR-J3-_B_ and MR-J3W-_B_ => MR-J4-_B_ and MR-J4W2-_B_

Parameter No.	Name	Initial value	Setting value	Description
PA04	Function selection A-1	2000h	-	Forced stop deceleration function selection To configure the same operation status as those for MR-J3-_B_, select "Forced stop deceleration function disabled (EM1)".
PA09	Auto tuning response	-	-	Auto tuning response setting Adjust the gain value again after the replacement.
PA10	In-position range	-	-	In-position range When the setting of MR-J3-_B_ is larger than 4095 pulses, it will be converted into 65535 pulses. Check for any problems of the equipment.
PA15	Encoder output pulses	-	-	Encoder output pulses When the setting of MR-J3-_B_ is larger than 4095 pulses and the output dividing ratio setting is selected, 65535 pulses will be set. Check for any problems of the equipment.
PC03	Encoder output pulse selection	-	-	Encoder output pulse setting selection To use "_4_": Encoder pulse through output setting", use MR-J4-_B_ with the software version A5 or later. A parameter error will occur when the software version A4 or earlier is used.
PC11	Analog monitor 1 offset	-	-	Not converted by the parameter converter function. Set the value as required.
PC12	Analog monitor 2 offset	-	-	Not converted by the parameter converter function. Set the value as required.
PC13	Analog monitor feedback position output standard data Low	-	-	Set the value as required.
PC14	Analog monitor feedback position output standard data High	-	-	Set the value as required.
PD15	Driver communication setting	-	-	<ul style="list-style-type: none"> ▪ Master axis operation selection ▪ Slave axis operation selection Use MR-J4-_B_ with the software version A8 or later to use this function. A parameter error will occur when MR-J4-_B_ with the software version A7 or earlier is used.
PD16	Driver communication setting - Master - Transmit data selection 1	-	-	Use MR-J4-_B_ with the software version A8 or later to use this function. A parameter error will occur when MR-J4-_B_ with the software version A7 or earlier is used.
PD17	Driver communication setting - Master - Transmit data selection 2	-	-	Use MR-J4-_B_ with the software version A8 or later to use this function. A parameter error will occur when MR-J4-_B_ with the software version A7 or earlier is used.
PD20	Driver communication setting - Slave - Master axis No. selection 1	-	-	Use MR-J4-_B_ with the software version A8 or later to use this function. A parameter error will occur when MR-J4-_B_ with the software version A7 or earlier is used.
PD30	Master-slave operation - Torque command coefficient on slave	-	-	Use MR-J4-_B_ with the software version A8 or later to use this function. A parameter error will occur when MR-J4-_B_ with the software version A7 or earlier is used.
PD31	Master-slave operation - Speed limit coefficient on slave	-	-	Use MR-J4-_B_ with the software version A8 or later to use this function. A parameter error will occur when MR-J4-_B_ with the software version A7 or earlier is used.
PD32	Master-slave operation - Speed limit adjusted value on slave	-	-	Use MR-J4-_B_ with the software version A8 or later to use this function. A parameter error will occur when MR-J4-_B_ with the software version A7 or earlier is used.

Note. For items that have no setting value listed in the table, refer to "Part 3: Review on Replacement of MR-J3-_B_ with MR-J4-_B_", "Part 4: Review on Replacement of MR-J3W-_B_ with MR-J4W2-_B_"..

Part 8: Common Reference Material

(2) MR-J3W-_B => MR-J4W2-_B

Parameter No.	Name	Initial value	Setting value	Description
PC01	Error excessive alarm level	-	-	Although the initial values of the MR-J3-_B_ and MR-J3W-_B_ are different, the same operation status is performed. Also, the setting ranges are different. Check the setting values and change them as necessary.
PC03	Encoder output pulse selection	-	-	Although the initial values of the MR-J3-_B_ and MR-J3W-_B_ are different, the values are overwritten with the setting values on the controller side (parameter of MR-J3-_B_) after power-on.

Note. For items that have no setting value listed in the table, refer to "Part 4: Review on Replacement of MR-J3W-_B_ with MR-J4W2-_B_".

(3) MR-J3W-0303BN6 => MR-J4W2-0303B6

Parameter No.	Name	Initial value	Setting value	Description
PC05	Function selection C-2	-	-	Select a voltage to be connected to the main circuit power supply with an MR-J4W2-0303B6 servo amplifier. Main circuit power supply the characteristics of the servo motor vary depending on whether 48 V DC or 24 V DC is used. [Pr. PC05]: "_ 0 _ _" DC 48 V (Initial value) "_ 1 _ _" DC 24 V
Po04	Main circuit power supply selection	-	-	The setting of this digit in the J3 compatibility mode is the same as the MR-J3W-0303BN6 servo amplifier. Set it with [Pr. Po04]. Main circuit power supply the characteristics of the servo motor vary depending on whether 48 V DC or 24 V DC is used. [Pr. Po04]: "0 _ _ _" DC 48 V (Initial value) "1 _ _ _" DC 24 V

Note. For items that have no setting value listed in the table, refer to "Part 4: Review on Replacement of MR-J3W-_B_ with MR-J4W2-_B_".

Part 8: Common Reference Material

4. COMMUNICATION FUNCTION (MITSUBISHI GENERAL-PURPOSE AC SERVO PROTOCOL)

POINT
<ul style="list-style-type: none">● RS-422 serial communication function is supported by servo amplifier with software version A3 or later.● The USB communication function (CN5 connector) and the RS-422 communication function (CN3 connector) are mutually exclusive functions. They cannot be used together.● This function is not available with MR-J4-_B_(-RJ), MR-J4-_GF_(-RJ) and MR-J4W2-_B_ servo amplifiers.● For replacing MR-J3-_T_ with MR-J4-_A_-RJ, refer to "Part 6".

You can operate servo driving, parameter change, monitor function, etc. using RS-422 communication (Mitsubishi general-purpose AC servo protocol) with the servo amplifier.

Part 8: Common Reference Material

4.1 Structure

4.1.1 Configuration diagram

(1) Single axis

Operate the single-axis servo amplifier. It is recommended to use the following cable.

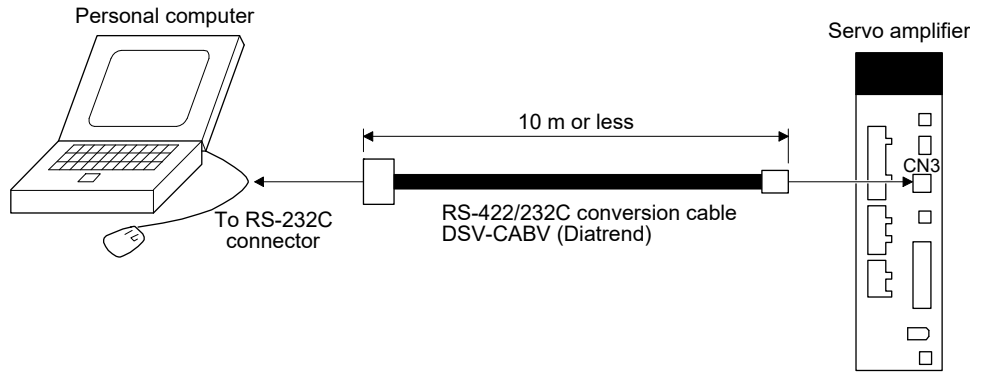

(2) Multi-drop connection

(a) Diagrammatic sketch

Up to 32 axes of servo amplifiers from stations 0 to 31 can be operated on the same bus.

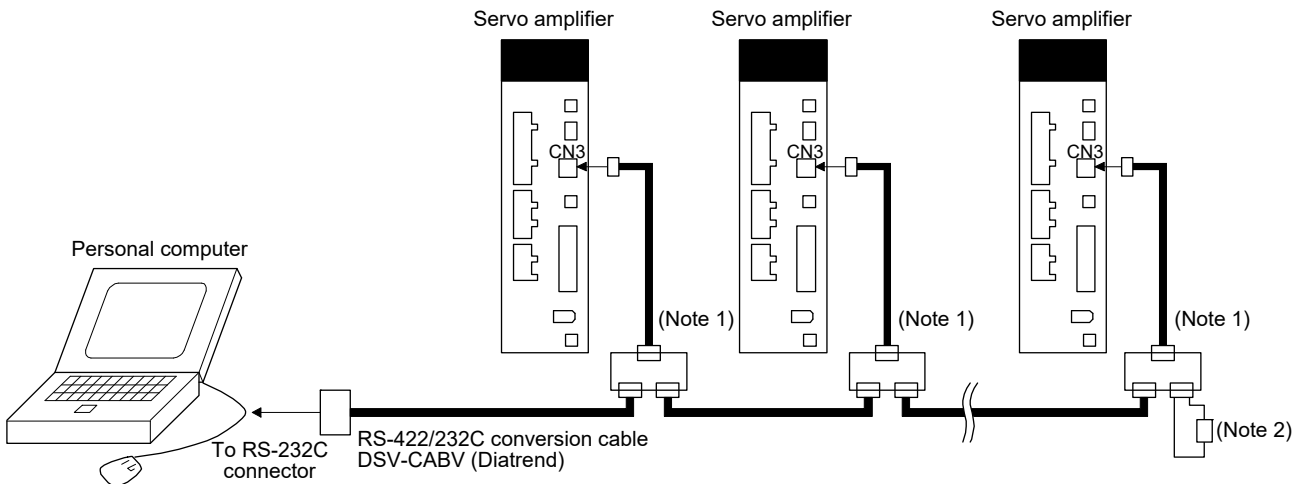

Note 1. The BMJ-8 (Hachiko Electric) is recommended as the branch connector.

Note 2. The final axis must be terminated between RDP (pin No.3) and RDN (pin No.6) on the receiving side (servo amplifier) with a 150 Ω resistor.

Part 8: Common Reference Material

(b) Cable connection diagram
Wire the cables as follows.

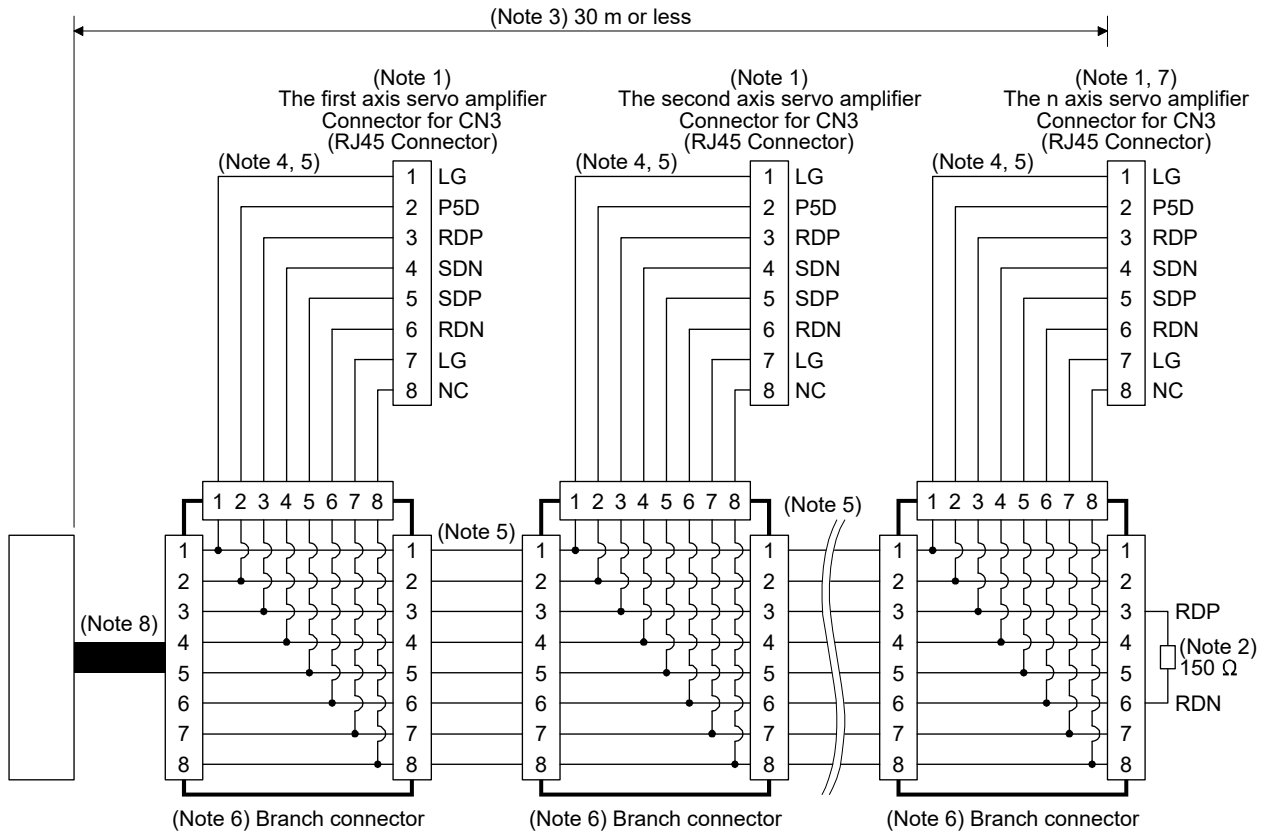

Note 1. Recommended connector (Hirose Electric)
Plug: TM10P-88P
Connection tool: CL250-0228-1
The following shows pin assignment viewed from connector wiring section.

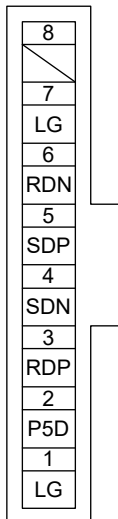

- The final axis must be terminated between RDP (pin No.3) and RDN (pin No.6) on the receiving side (servo amplifier) with a 150 Ω resistor.
- The overall length is 30 m or less in low-noise environment.
- The wiring between the branch connector and servo amplifier should be as short as possible.
- Use the EIA568-compliant cable (10BASE-T cable, etc.).
- Recommended branch connector: BMJ-8 (Hachiko Electric)
- $n \leq 32$ (Up to 32 axes can be connected.)
- RS-422/232C conversion cable DSV-CABV (Diatrend)

Part 8: Common Reference Material

4.1.2 Precautions for using RS-422/RS-232C/USB communication function

Note the following to prevent an electric shock and malfunction of the servo amplifier.

(1) Power connection of personal computers

Connect your personal computer with the following procedures.

(a) When you use a personal computer with AC power supply

- 1) When using a personal computer with a three-core power plug or power plug with grounding wire, use a three-pin socket or ground the grounding wire.
- 2) When your personal computer has two-core plug and has no grounding wire, connect the personal computer to the servo amplifier with the following procedures.
 - a) Disconnect the power plug of the personal computer from an AC power socket.
 - b) Check that the power plug was disconnected and connect the device to the servo amplifier.
 - c) Connect the power plug of the personal computer to the AC power socket.

(b) When you use a personal computer with battery

You can use as it is.

(2) Connection with other devices using servo amplifier communication function

When the servo amplifier is charged with electricity due to connection with a personal computer and the charged servo amplifier is connected with other devices, the servo amplifier or the connected devices may malfunction. Connect the servo amplifier and other devices with the following procedures.

- (a) Shut off the power of the device for connecting with the servo amplifier.
- (b) Shut off the power of the servo amplifier which was connected with the personal computer and check the charge lamp is off.
- (c) Connect the device with the servo amplifier.
- (d) Turn on the power of the servo amplifier and the device.

Part 8: Common Reference Material

4.2 Communication specifications

4.2.1 Outline of communication

Receiving a command, this servo amplifier returns data. The device which gives the command (e.g. personal computer) is called a master station and the device (servo amplifier) which returns data in response to the command is called a slave station. When fetching data successively, the master station repeatedly commands the slave station to send data.

Item	Definition	
Baud rate [bps]	9600/19200/38400/57600/115200 asynchronous system	
Transfer code	Start bit	1 bit
	Data bit	8 bits
	Parity bit	1 bit (even)
	Stop bit	1 bit
Transfer method	Character method	Half-duplex communication method

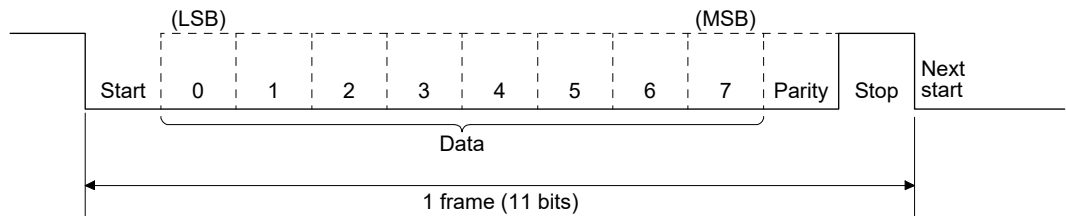

4.2.2 Parameter setting

When the RS-422 communication function is used to operate the servo, set the communication specifications of the servo amplifier with the parameters.

To enable the parameter values, cycle the power after setting.

(1) Serial communication baud rate

Select the communication speed. Match this value to the communication speed of the sending end (master station).

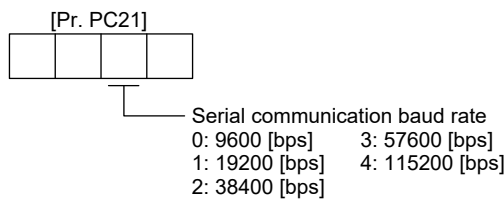

(2) RS-422 communication response delay time

Set the time from when the servo amplifier (slave station) receives communication data to when it returns data. Set "0" to return data in less than 800 μs or "1" to return data in 800 μs or longer.

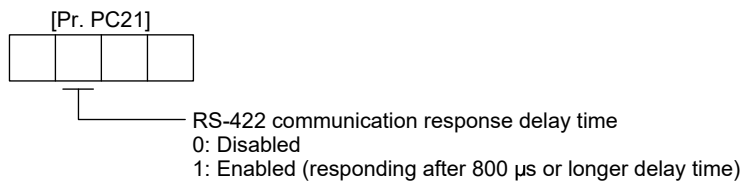

(3) Station No. setting

Set the station No. of the servo amplifier to [Pr. PC20]. The setting range is station No. 0 to 31.

Part 8: Common Reference Material

4.3 Protocol

4.3.1 Transmission data configuration

Since up to 32 axes may be connected to the bus, add a station No. to the command, data No., etc. to determine the destination servo amplifier of data communication. Set the station No. to each servo amplifier using the parameters. Transmission data is enabled for the servo amplifier of the specified station No. When "*" is set as the station No. added to the transmission data, the transmission data is enabled for all servo amplifiers connected. However, when return data is required from the servo amplifier in response to the transmission data, set "0" to the station No. of the servo amplifier which must provide the return data.

(1) Transmission of data from the controller to the servo

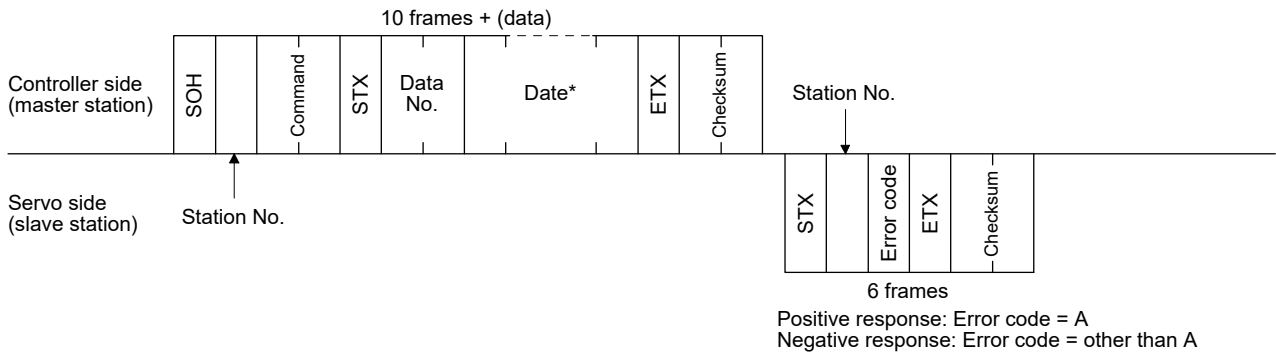

(2) Transmission of data request from the controller to the servo

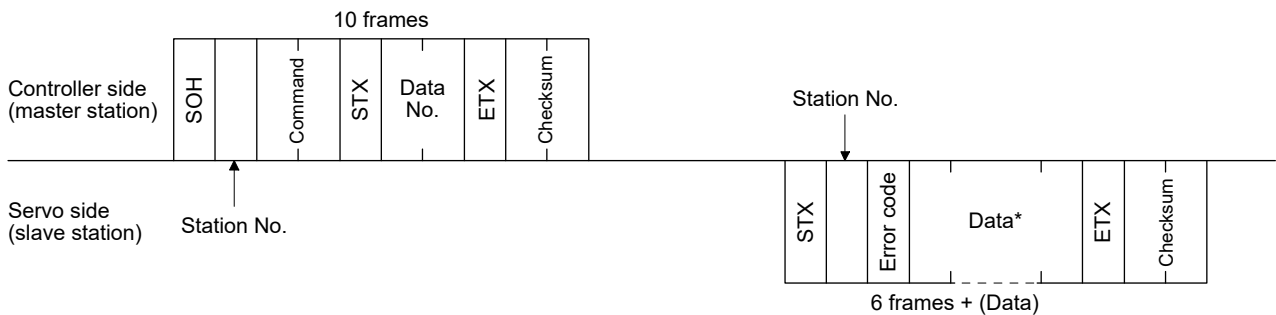

(3) Recovery of communication status by time-out

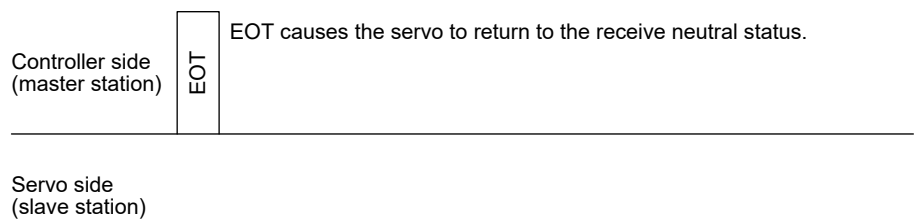

(4) Data frames

The data length depends on the command.

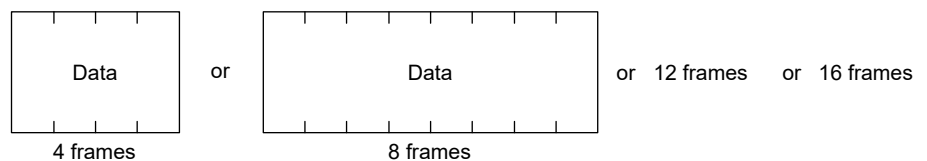

Part 8: Common Reference Material

4.3.2 Character codes

(1) Control codes

Code name	Hexadecimal (ASCII code)	Description	Personal computer terminal key operation (general)
SOH	01H	start of head	ctrl + A
STX	02H	start of text	ctrl + B
ETX	03H	end of text	ctrl + C
EOT	04H	end of transmission	ctrl + D

(2) Codes for data

ASCII unit codes are used.

	b8	0	0	0	0	0	0	0	0
	b7	0	0	0	0	1	1	1	1
	b6	0	0	1	1	0	0	1	1
	b5	0	1	0	1	0	1	0	1

b8 to b5	b4	b3	b2	b1
	0	0	0	0
	0	0	0	1
	0	0	1	0
	0	0	1	1
	0	1	0	0
	0	1	0	1
	0	1	1	0
	0	1	1	1
	1	0	0	0
	1	0	0	1
	1	0	1	0
	1	0	1	1
	1	1	0	0
	1	1	0	1
	1	1	1	0
	1	1	1	1

R \ C	0	1	2	3	4	5	6	7
0	NUL	DLE	Space	0	@	P	`	p
1	SOH	DC ₁	!	1	A	Q	a	q
2	STX	DC ₂	"	2	B	R	b	r
3	ETX	DC ₃	#	3	C	S	c	s
4			\$	4	D	T	d	t
5			%	5	E	U	e	u
6			&	6	F	V	f	v
7			'	7	G	W	g	w
8			(8	H	X	h	x
9)	9	I	Y	i	y
10			*	:	J	Z	j	z
11			+	;	K	[k	{
12			,	<	L	¥	l	
13			-	=	M]	m	}
14			.	>	N	^	n	~
15			/	?	O	_	o	DEL

(3) Station numbers

You may set 32 station Nos. from station 0 to station 31 and the ASCII unit codes are used to specify the stations.

Station No.	0	1	2	3	4	5	6	7	8	9	10	11	12	13	14	15
ASCII code	0	1	2	3	4	5	6	7	8	9	A	B	C	D	E	F

Station No.	16	17	18	19	20	21	22	23	24	25	26	27	28	29	30	31
ASCII code	G	H	I	J	K	L	M	N	O	P	Q	R	S	T	U	V

For example, "30H" is transmitted in hexadecimal for the station No. "0" (axis 1).

Part 8: Common Reference Material

4.3.3 Error codes

Error codes are used in the following cases and an error code of single-code length is transmitted. Receiving data from the master station, the slave station sends the error code corresponding to that data to the master station. The error code sent in upper case indicates that the servo is normal and the one in lower case indicates that an alarm occurred.

Error code		Error name	Explanation	Remark
Servo: normal	Servo: alarm			
[A]	[a]	Normal	Data transmitted was processed normally.	Positive response
[B]	[b]	Parity error	Parity error occurred in the transmitted data.	Negative response
[C]	[c]	Checksum error	Checksum error occurred in the transmitted data.	
[D]	[d]	Character error	The transmitted character is out of specifications.	
[E]	[e]	Command error	The transmitted command is out of specifications.	
[F]	[f]	Data No. error	The transmitted data No. is out of specifications.	

4.3.4 Checksum

The checksum is an ASCII-coded hexadecimal representing the lower two digits of the sum of ASCII-coded hexadecimal numbers up to ETX, with the exception of the first control code (STX or SOH).

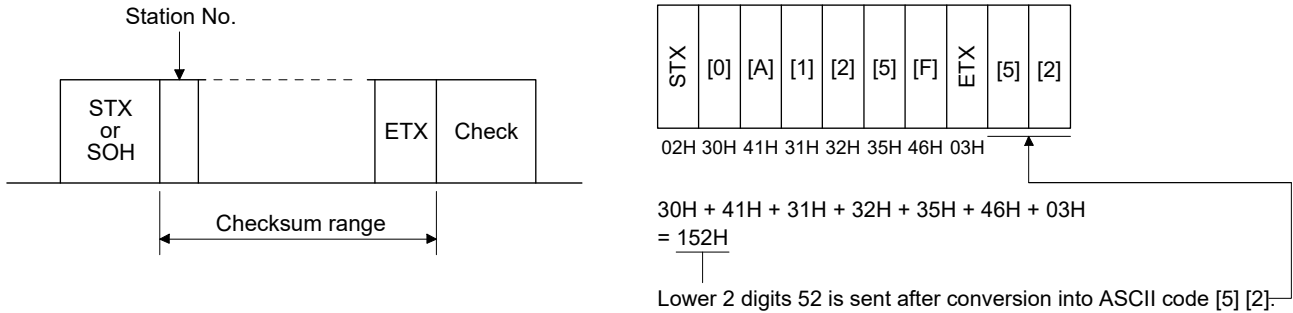

4.3.5 Time-out processing

The master station transmits EOT when the slave station does not start return processing (STX is not received) 300 [ms] after the master station has ended communication processing. 100 ms after that, the master station retransmits the message. Time-out occurs if the slave station does not answer after the master station has performed the above communication processing three times. (Communication error)

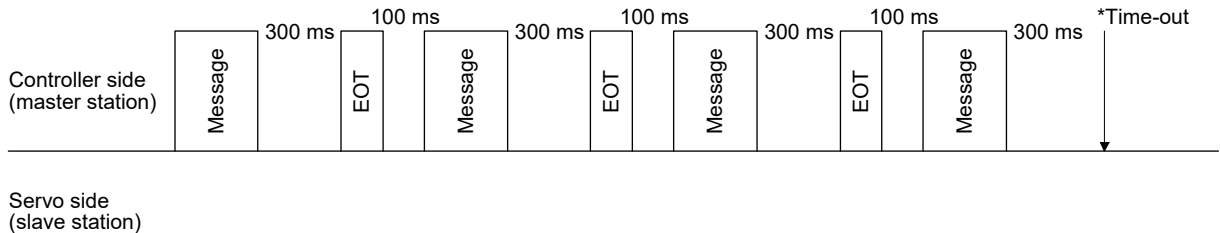

Part 8: Common Reference Material

4.3.6 Retry processing

When a fault occurs in communication between the master and slave stations, the error code in the response data from the slave station is a negative response code ([B] to [F], [b] to [f]). In this case, the master station retransmits the message which was sent at the occurrence of the fault (retry processing). A communication error occurs if the above processing is repeated and results in the error three or more consecutive times.

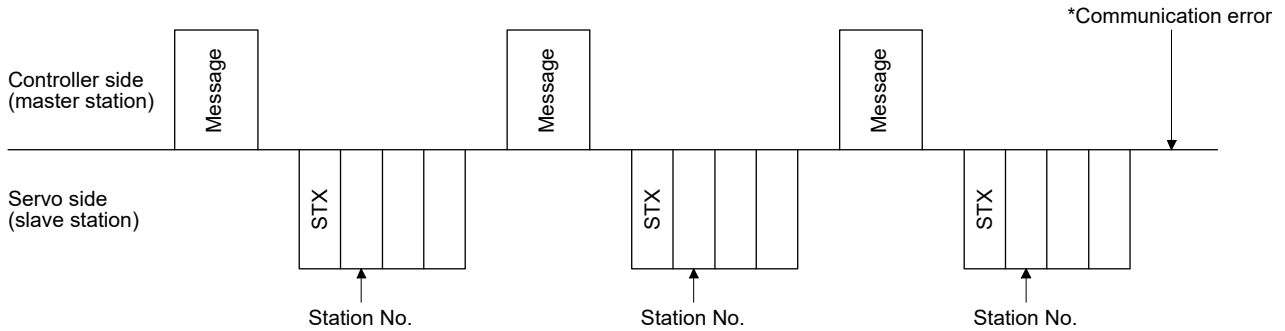

Similarly, when the master station detects a fault (e.g. checksum, parity) in the response data from the slave station, the master station retransmits the message which was sent at the occurrence of the fault. A communication error occurs if the retry processing is performed three times.

4.3.7 Initialization

After the slave station is switched on, it cannot return to communication until the internal initialization processing terminates. Hence, at power-on, ordinary communication should be started after.

- (1) Wait for 3.5 s or longer after the slave station is switched on.
- (2) Check that normal communication can be made by reading the parameter or other data which does not pose any safety problems.

Part 8: Common Reference Material

4.3.8 Communication procedure example

The following example reads the set value of alarm history (last alarm) from the servo amplifier of station 0.

Data item	Value	Description
Station No.	0	Servo amplifier station 0
Command	3 3	Reading command
Data No.	1 0	Alarm history (last alarm)

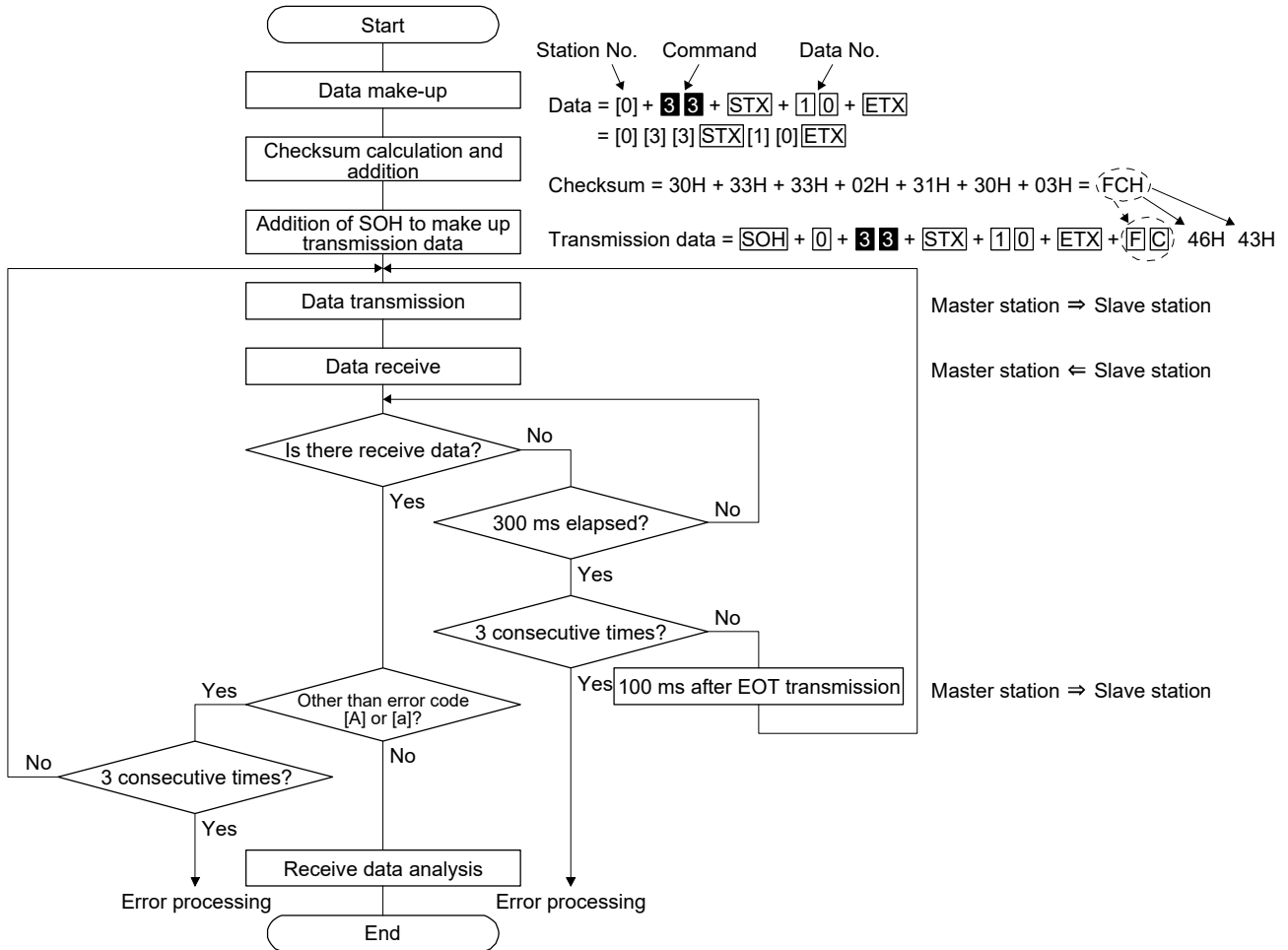

Part 8: Common Reference Material

4.4 Command and data No. list

POINT															
<ul style="list-style-type: none"> ● Even if a command or data No. is the same between different model servo amplifiers, its description may differ. ● Commands of MR-J3- _A_ are available. <p>The following commands are also available.</p> <table border="1"> <thead> <tr> <th>Description</th> <th>MR-J3-/J4</th> <th>Only MR-J4</th> </tr> </thead> <tbody> <tr> <td>Current value of each parameter</td> <td>[0] [5]</td> <td>[1] [5]</td> </tr> <tr> <td>Upper limit value of each parameter setting range</td> <td>[0] [6]</td> <td>[1] [6]</td> </tr> <tr> <td>Lower limit value of each parameter setting range</td> <td>[0] [7]</td> <td>[1] [7]</td> </tr> <tr> <td>Writing each parameter</td> <td>[8] [4]</td> <td>[9] [4]</td> </tr> </tbody> </table>	Description	MR-J3-/J4	Only MR-J4	Current value of each parameter	[0] [5]	[1] [5]	Upper limit value of each parameter setting range	[0] [6]	[1] [6]	Lower limit value of each parameter setting range	[0] [7]	[1] [7]	Writing each parameter	[8] [4]	[9] [4]
Description	MR-J3-/J4	Only MR-J4													
Current value of each parameter	[0] [5]	[1] [5]													
Upper limit value of each parameter setting range	[0] [6]	[1] [6]													
Lower limit value of each parameter setting range	[0] [7]	[1] [7]													
Writing each parameter	[8] [4]	[9] [4]													

4.4.1 Reading command

(1) Status display (command [0] [1])

Command	Data No.	Description	MR-J3- _A_		MR-J4- _A_	
			Status display	Frame length	Status display	Frame length
[0] [1]	[0] [0]	Status display symbol and unit	Cumulative feedback pulses	16	Cumulative feedback pulses	16
	[0] [1]		Servo motor speed		Motor-side cumu. feedback pulses (after gear)	
	[0] [2]		Droop pulses		Servo motor speed	
	[0] [3]		Cumulative command pulses		Droop pulses	
	[0] [4]		Command pulse frequency		Motor-side droop pulses	
	[0] [5]		Analog speed command voltage		Cumulative command pulses	
	[0] [6]		Analog speed limit voltage		Command pulse frequency	
	[0] [7]		Analog torque limit voltage		Analog speed command voltage	
	[0] [8]		Analog torque command voltage		Analog speed limit voltage	
	[0] [9]		Regenerative load ratio		Analog torque limit voltage	
	[0] [A]		Effective load ratio		Analog torque command voltage	
	[0] [B]		Peak load ratio		Regenerative load ratio	
	[0] [C]		Instantaneous torque		Effective load ratio	
	[0] [D]		Position within one-revolution		Peak load ratio	
	[0] [E]		ABS counter		Instantaneous torque	
[8] [0]	Status display data value and processing information	Cumulative feedback pulses	12	Cumulative feedback pulses	12	
[8] [1]		Servo motor speed		Motor-side cumu. feedback pulses (after gear)		
[8] [2]		Droop pulses		Servo motor speed		
[8] [3]		Cumulative command pulses		Droop pulses		
[8] [4]		Command pulse frequency		Motor-side droop pulses		
[8] [5]		Analog speed command voltage		Cumulative command pulses		
[8] [6]		Analog speed limit voltage		Command pulse frequency		
[8] [7]		Analog torque limit voltage		Analog speed command voltage		
[8] [7]	Analog torque command voltage	Analog speed limit voltage				
[8] [7]	Regenerative load ratio	Analog torque limit voltage				
[8] [7]	Regenerative load ratio	Analog torque command voltage				
[8] [7]	Regenerative load ratio	Regenerative load ratio				

Part 8: Common Reference Material

Command	Data No.	Description	MR-J3- _A_		MR-J4- _A_	
			Status display	Frame length	Status display	Frame length
[0] [1]	[8] [8]	Status display data value and processing information	Effective load ratio	12	Effective load ratio	12
	[8] [9]		Peak load ratio		Peak load ratio	
	[8] [A]		Instantaneous torque		Instantaneous torque	
	[8] [B]		Position within one-revolution		Position within one-revolution Motor encoder position within one-revolution Virtual position within one-revolution	
	[8] [C]		ABS counter		ABS counter Motor encoder ABS counter Virtual ABS counter	
	[8] [D]		Load to motor inertia ratio		Load to motor inertia ratio	
	[8] [E]		Bus voltage		Bus voltage	

Part 8: Common Reference Material

(2) Parameters (command [0] [4]/[0] [5]/[1] [5]/[0] [6]/[1] [6]/[0] [7]/[1] [7]/[0] [8]/[0] [9])

Command	Data No.	MR-J3-_A_		MR-J4-_A_	
		Description	Frame length	Description	Frame length
[0] [4]	[0] [1]	Parameter group read 0000: Basic setting parameter (Pr. PA__) 0001: Gain filter parameter (Pr. PB__) 0002: Extension setting parameter (Pr. PC__) 0003: I/O setting parameter (Pr. PD__)	4	Parameter group reading 0000: Basic setting parameters (Pr. PA__) 0001: Gain/filter parameters (Pr. PB__) 0002: Extension setting parameters (Pr. PC__) 0003: I/O setting parameters (Pr. PD__) 0004: Extension setting 2 parameters (Pr. PE__) 0005: Extension setting 3 parameters (Pr. PF__)	4
[0] [5]	[0] [1] to [F] [F]	Current values of parameters Reads the current values of the parameters in the parameter group specified with the command [8] [5] + data No. [0] [0]. Before reading the current values, therefore, always specify the parameter group with the command [8] [5] + data No. [0] [0]. The decimal equivalent of the data No. value (hexadecimal) corresponds to the parameter number.	8	Current values of parameters Reads the current values of the parameters in the parameter group specified with the command [8] [5] + data No. [0] [0]. Before reading the current values, therefore, always specify the parameter group with the command [8] [5] + data No. [0] [0]. The decimal equivalent of the data No. value (hexadecimal) corresponds to the parameter No. Command [1] [5]: Frame length 12 is available.	8
[0] [6]	[0] [1] to [F] [F]	Upper limit values of parameter setting ranges Reads the permissible upper limit values of the parameters in the parameter group specified with the command [8] [5] + data No. [0] [0]. Before reading the upper limit values, therefore, always specify the parameter group with the command [8] [5] + data No. [0] [0]. The decimal equivalent of the data No. value (hexadecimal) corresponds to the parameter number.	8	Upper limit values of parameter setting ranges Reads the permissible upper limit values of the parameters in the parameter group specified with the command [8] [5] + data No. [0] [0]. Before reading the upper limit values, therefore, always specify the parameter group with the command [8] [5] + data No. [0] [0]. The decimal equivalent of the data No. value (hexadecimal) corresponds to the parameter No. Command [1] [6]: Frame length 12 is available.	8
[0] [7]	[0] [1] to [F] [F]	Lower limit values of parameter setting ranges Reads the permissible lower limit values of the parameters in the parameter group specified with the command [8] [5] data No. [0] [0]. Before reading the lower limit values, therefore, always specify the parameter group with the command [8] [5] data No. [0] [0]. The decimal equivalent of the data No. value (hexadecimal) corresponds to the parameter number.	8	Lower limit values of parameter setting ranges Reads the permissible lower limit values of the parameters in the parameter group specified with the command [8] [5] + data No. [0] [0]. Before reading the lower limit values, therefore, always specify the parameter group with the command [8] [5] + data No. [0] [0]. The decimal equivalent of the data No. value (hexadecimal) corresponds to the parameter No. Command [1] [7]: Frame length 12 is available.	8
[0] [8]	[0] [1] to [F] [F]	Abbreviations of parameters Reads the abbreviations of the parameters in the parameter group specified with the command [8] [5] + data No. [0] [0]. Before reading the abbreviations, therefore, always specify the parameter group with the command [8] [5] + data No. [0] [0]. The decimal equivalent of the data No. value (hexadecimal) corresponds to the parameter number.	12	Parameter symbols Reads the symbols of the parameters in the parameter group specified with the command [8] [5] + data No. [0] [0]. Before reading the symbols, therefore, always specify the parameter group with the command [8] [5] + data No. [0] [0]. The decimal equivalent of the data No. value (hexadecimal) corresponds to the parameter No.	12
[0] [9]	[0] [1] to [F] [F]	Write enable/disable of parameters Reads write enable/disable of the parameters in the parameter group specified with the command [8] [5] + data No. [0] [0]. Before reading write enable/disable, therefore, always specify the parameter group with the command [8] [5] + data No. [0] [0]. 0000: Write enabled 0001: Write disabled	4	Writing enable/disable of parameters Reads writing enable/disable of the parameters in the parameter group specified with the command [8] [5] + data No. [0] [0]. Before reading the lower limit values, therefore, always specify the parameter group with the command [8] [5] + data No. [0] [0]. 0000: Writing enabled 0001: Writing disabled	4

Part 8: Common Reference Material

(3) External I/O signals (command [1] [2])

Command	Data No.	MR-J3-_A_ / MR-J4-_A_	Frame length
		Description	
[1] [2]	[0] [0]	Input device status	8
	[4] [0]	External input pin status	
	[6] [0]	Status of input device turned on by communication	
	[8] [0]	Output device status	
	[C] [0]	External output pin status	

(4) Alarm history (command [3] [3])

Command	Data No.	Description	MR-J3-_A_		MR-J4-_A_	
			Alarm occurrence sequence	Frame length	Alarm occurrence sequence	Frame length
[3] [3]	[1] [0]	Alarm No. in alarm history	most recent alarm	4	Most recent alarm	4
	[1] [1]		first alarm in past		First alarm in past	
	[1] [2]		second alarm in past		Second alarm in past	
	[1] [3]		third alarm in past		Third alarm in past	
	[1] [4]		fourth alarm in past		Fourth alarm in past	
	[1] [5]		fifth alarm in past		Fifth alarm in past	
	[1] [6]				Sixth alarm in past	
	[1] [7]				Seventh alarm in past	
	[1] [8]				Eighth alarm in past	
	[1] [9]				Ninth alarm in past	
	[1] [A]				Tenth alarm in past	
	[1] [B]				Eleventh alarm in past	
	[1] [C]				Twelfth alarm in past	
	[1] [D]				Thirteenth alarm in past	
	[1] [E]				Fourteenth alarm in past	
	[1] [F]				Fifteenth alarm in past	
	[2] [0]		Alarm occurrence time in alarm history		most recent alarm	
[2] [1]	first alarm in past	First alarm in past				
[2] [2]	second alarm in past	Second alarm in past				
[2] [3]	third alarm in past	Third alarm in past				
[2] [4]	fourth alarm in past	Fourth alarm in past				
[2] [5]	fifth alarm in past	Fifth alarm in past				
[2] [6]		Sixth alarm in past				
[2] [7]		Seventh alarm in past				
[2] [8]		Eighth alarm in past				
[2] [9]		Ninth alarm in past				
[2] [A]		Tenth alarm in past				
[2] [B]		Eleventh alarm in past				
[2] [C]		Twelfth alarm in past				
[2] [D]		Thirteenth alarm in past				
[2] [E]		Fourteenth alarm in past				
[2] [F]		Fifteenth alarm in past				

(5) Current alarm (Command [0][2])

Command	Data No.	MR-J3-_A_ / MR-J4-_A_	Frame length
		Description	
[0] [2]	[0] [0]	Current alarm No.	4

Part 8: Common Reference Material

(6) Status display at alarm occurrence (command [3] [5])

Command	Data No.	Description	MR-J3- _A_		MR-J4- _A_	
			Status display	Frame length	Status display	Frame length
[3] [5]	[8] [0]	Status display data value and processing information	Cumulative feedback pulses	12	Cumulative feedback pulses	12
	[8] [1]		Servo motor speed		Motor-side cumu. feedback pulses (after gear)	
	[8] [2]		Droop pulses		Servo motor speed	
	[8] [3]		Cumulative command pulses		Droop pulses	
	[8] [4]		Command pulse frequency		Motor-side droop pulses	
	[8] [5]		Analog speed command voltage Analog speed limit voltage		Cumulative command pulses	
	[8] [6]		Analog torque command voltage Analog torque limit voltage		Command pulse frequency	
	[8] [7]		Regenerative load ratio		Analog speed command voltage Analog speed limit voltage	
	[8] [8]		Effective load ratio		Analog torque command voltage Analog torque limit voltage	
	[8] [9]		Peak load ratio		Regenerative load ratio	
	[8] [A]		Instantaneous torque		Effective load ratio	
	[8] [B]		Position within one-revolution		Peak load ratio	
	[8] [C]		ABS counter		Instantaneous torque	
	[8] [D]		Load to motor inertia ratio		Position within one-revolution Motor encoder position within one-revolution Virtual position within one-revolution	
[8] [E]	Bus voltage	ABS counter Motor encoder ABS counter Virtual ABS counter				
		Load to motor inertia ratio				
		Bus voltage				

(7) Test operation mode (command [0] [0])

Command	Data No.	MR-J3- _A_ /MR-J4- _A_	
		Description	Frame length
[0] [0]	[1] [2]	Test operation mode reading 0000: Normal mode (not test operation mode) 0001: JOG operation 0002: Positioning operation 0003: Motor-less operation 0004: Output signal (DO) forced output	4

(8) Software version (command [0] [2])

Command	Data No.	MR-J3- _A_ /MR-J4- _A_	
		Description	Frame length
[0] [2]	[9] [0]	Servo motor-side pulse unit absolute position	8
	[9] [1]	Command unit absolute position	8
	[7] [0]	Software version	16

Part 8: Common Reference Material

4.4.2 Writing commands

(1) Status display (command [8] [1])

Command	Data No.	MR-J3- _A_/MR-J4- _A_		
		Description	Setting range	Frame length
[8] [1]	[0] [0]	Status display data deletion	1EA5	4

(2) Parameters (command [8] [4]/[9] [4]/[8] [5])

Command	Data No.	MR-J3- _A_			MR-J4- _A_		
		Description	Setting range	Frame length	Description	Setting range	Frame length
[8] [4]	[0] [1] to [F] [F]	Write of parameters Writes the values of the parameters in the parameter group specified with the command [8] [5] data No. [0] [0]. Before writing the values, therefore, always specify the parameter group with the command [8] [5] data No. [0] [0]. The decimal equivalent of the data No. value (hexadecimal) corresponds to the parameter number.	Depending on the parameter	8	Writing each parameter Writes the values of the parameters in the parameter group specified with the command [8] [5] + data No. [0] [0]. Before writing the values, therefore, always specify the parameter group with the command [8] [5] + data No. [0] [0]. The decimal equivalent of the data No. value (hexadecimal) corresponds to the parameter No. Command [9] [4]: Frame length 12 is available.	Depending on the parameter	8
[8] [5]	[0] [0]	Parameter group write 0000: Basic setting parameter ((Pr. PA_ _)) 0001: Gain filter parameter ((Pr. PB_ _)) 0002: Extension setting parameter ((Pr. PC_ _)) 0003: I/O setting parameter ((Pr. PD_ _))	0000 to 0003	4	Parameter group writing 0000: Basic setting parameters ((Pr. PA_ _)) 0001: Gain/filter parameters ((Pr. PB_ _)) 0002: Extension setting parameters ((Pr. PC_ _)) 0003: I/O setting parameters ((Pr. PD_ _)) 0004: Extension setting 2 parameters ((Pr. PE_ _)) 0005: Extension setting 3 parameters ((Pr. PF_ _))	0000 to 0005	4

(3) External I/O signals (command [9] [2])

Command	Data No.	MR-J3- _A_/MR-J4- _A_		
		Description	Setting range	Frame length
[9] [2]	[6] [0]	Communication input device signal	Refer to section 4.5.5.	8

(4) Alarm history (command [8] [2])

Command	Data No.	MR-J3- _A_/MR-J4- _A_		
		Description	Setting range	Frame length
[8] [2]	[2] [0]	Alarm history clear	1EA5	4

Part 8: Common Reference Material

(5) Current alarm (command [8] [2])

Command	Data No.	MR-J3- _A_ /MR-J4- _A_		
		Description	Setting range	Frame length
[8] [2]	[0] [0]	Alarm clear	1EA5	4

(6) I/O device prohibition (command [9] [0])

Command	Data No.	MR-J3- _A_ /MR-J4- _A_		
		Description	Setting range	Frame length
[9] [0]	[0] [0]	Turns off the input device, external analog input signal or pulse train input, except EMG, LSP and LSN, independently of the external on/off status.	1EA5	4
	[0] [3]	Disables all output devices (DO).		
	[1] [0]	Cancels the prohibition of the input device, external analog input signal or pulse train input, except EMG, LSP and LSN.		
	[1] [3]	Cancels the prohibition of the output device.		

(7) Operation mode selection (command [8] [B])

Command	Data No.	MR-J3- _A_			MR-J4- _A_		
		Description	Setting range	Frame length	Description	Setting range	Frame length
[8] [B]	[0] [0]	Operation mode switching 0000: Test operation mode cancel 0001: JOG operation 0002: Positioning operation 0003: Motorless operation 0004: Output signal (DO) forced output	0000 to 0004	4	Selection of test operation mode 0000: Test operation mode cancel 0001: JOG operation 0002: Positioning operation 0004: Output signal (DO) forced output	0000 to 0002, 0004	4

(8) Test operation mode data (command [9] [2], [A] [0])

Command	Data No.	MR-J3- _A_ /MR-J4- _A_						
		Description	Setting range	Frame length				
[9] [2]	[0] [0]	Input signal for test operation	Refer to section 4.5.7.	8				
	[A] [0]	Forced output of signal pin	Refer to section 4.5.9.	8				
[A] [0]	[1] [0]	Writes the servo motor speed in the test operation mode (JOG operation and positioning operation).	0000 to 7FFF	4				
	[1] [1]	Writes the acceleration/deceleration time constant in the test operation mode (JOG operation and positioning operation).	00000000 to 7FFFFFFF	8				
	[2] [0]	Sets the travel distance in the test operation mode (Positioning operation).	00000000 to 7FFFFFFF	8				
	[2] [1]	Selects the positioning direction of test operation (positioning operation). <div style="text-align: center;"> <table border="1" style="display: inline-table; margin: 10px;"> <tr> <td style="padding: 5px;">0</td> <td style="padding: 5px;"> </td> <td style="padding: 5px;">0</td> <td style="padding: 5px;"> </td> </tr> </table> <p style="margin-left: 100px;"> 0: Forward rotation direction 1: Reverse rotation direction 0: Command pulse unit 1: Encoder pulse unit </p> </div>	0		0		0000 to 0101	4
	0		0					
[4] [0]	This is a start command for test operation (positioning operation).	1EA5	4					
[4] [1]	This is used to make a temporary stop during test operation (positioning operation). " _ " in the data indicates a blank. STOP: Temporary stop GO_ _ : Restart for remaining distance CLR_ _ : Remaining distance clear	STOP GO_ _ CLR_ _	4					

Part 8: Common Reference Material

4.5 Detailed explanations of commands

4.5.1 Data processing

When the master station transmits a command data No. or a command + data No. + data to a slave station, the servo amplifier returns a response or data in accordance with the purpose.

When numerical values are represented in these send data and receive data, they are represented in decimal, hexadecimal, etc.

Therefore, data must be processed in accordance with the application.

Since whether data must be processed or not and how to process data depend on the monitoring, parameters, etc., follow the detailed explanation of the corresponding command.

The following methods are how to process send and receive data when reading and writing data.

(1) Processing a read data

When the display type is 0, the eight-character data is converted from hexadecimal to decimal and a decimal point is placed according to the decimal point position information.

When the display type is 1, the eight-character data is used unchanged.

The following example indicates how to process the receive data "00300000929" given to show.

The receive data is as follows.

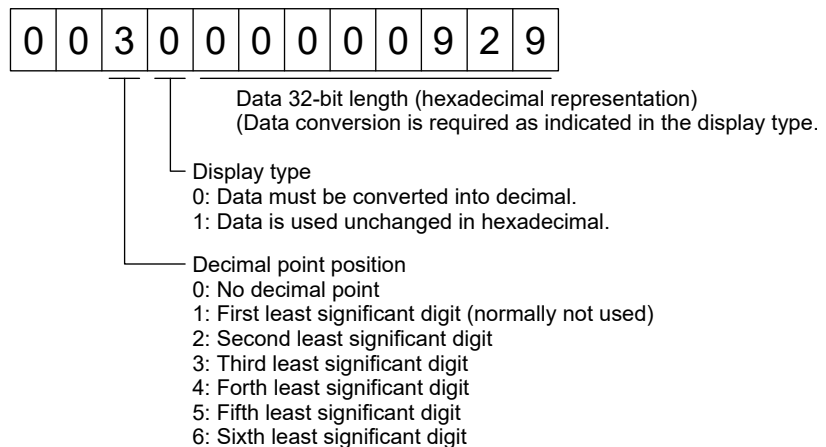

Since the display type is "0" in this case, the hexadecimal data is converted into decimal.

00000929H → 2345

As the decimal point position is "3", a decimal point is placed in the third least significant digit.

Hence, "23.45" is displayed.

Part 8: Common Reference Material

(2) Writing processed data

When the data to be written is handled as decimal, the decimal point position must be specified. If it is not specified, the data cannot be written. When the data is handled as hexadecimal, specify "0" as the decimal point position.

The data to be sent is the following value.

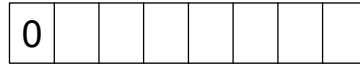

Data is transferred in hexadecimal

Decimal point position

0: No decimal point

1: First least significant digit

2: Second least significant digit

3: Third least significant digit

4: Forth least significant digit

5: Fifth least significant digit

For example, here is described how to process the set data when a value of "15.5" is sent.

Since the decimal point position is the second least significant digit, the decimal point position data is "2".

As the data to be sent is hexadecimal, the decimal data is converted into hexadecimal.

155 → 9B

Hence, "0200009B" is transmitted.

Part 8: Common Reference Material

4.5.2 Status display mode

(1) Reading the status display name and unit

The following shows how to read the status display name and unit.

(a) Transmission

Transmit the command [0] [1] and the data No. corresponding to the status display item to be read, [0] [0] to [0] [E] and [2] [0] to [2] [9]. (Refer of section 4.4.1.)

(b) Return

The slave station returns the status display name and unit requested.

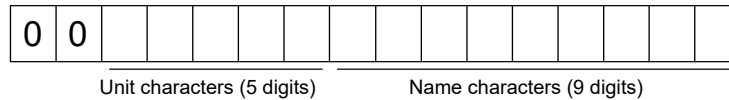

(2) Status display data reading

The following shows how to read the status display data and processing information.

(a) Transmission

Transmit the command [0] [1] and the data No. corresponding to the status display item to be read, [8] [0] to [8] [E] and [A] [0] to [A] [9]. (Refer of section 4.4.1.)

(b) Return

The slave station returns the status display data requested.

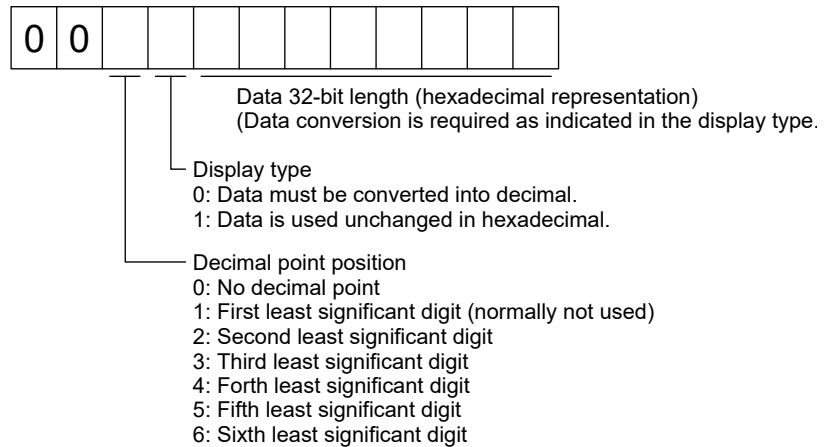

(3) Status display data clear

To clear the cumulative feedback pulse data of the status display, send this command immediately after reading each status display item. The data of the status display item transmitted is cleared to "0".

Command	Data No.	Data
[8] [1]	[0] [0]	1EA5

For example, after sending command [0] [1] and data No. [8] [0] and receiving the status display data, send command [8] [1], data No. [0] [0] and data [1EA5] to clear the cumulative feedback pulse value to "0".

Part 8: Common Reference Material

4.5.3 Parameter

(1) Specification of the parameter group

To read or write the parameter settings, etc., the group of the parameters to be operated must be specified in advance. Write data to the servo amplifier as follows to specify the parameter group.

Command	Data No.	Transmission data	Parameter group
[8] [5]	[0] [0]	0000	Basic setting parameters ([Pr. PA__])
		0001	Gain/filter parameters ([Pr. PB__])
		0002	Extension setting parameters ([Pr. PC__])
		0003	I/O setting parameters ([Pr. PD__])
		0004	Extension setting 2 parameters ([Pr. PE__])
		0005	Extension setting 3 parameters ([Pr. PF__])

(2) Parameter group reading

The following shows how to read the parameter group set with slave station.

(a) Transmission

Transmit command [0] [4] and data No. [0] [1].

Command	Data No.
[0] [4]	[0] [1]

(b) Return

The slave station returns the preset parameter group.

0	0	0	
---	---	---	--

Parameter group

0: Basic setting parameters ([Pr. PA__])

1: Gain/filter parameters ([Pr. PB__])

2: Extension setting parameters ([Pr. PC__])

3: I/O setting parameters ([Pr. PD__])

4: Extension setting 2 parameters ([Pr. PE__])

5: Extension setting 3 parameters ([Pr. PF__])

(3) Reading symbols

The following shows how to read symbols of parameters. Specify a parameter group in advance. (Refer to (1) of this section.)

(a) Transmission

Transmit the command [0] [8] and the data No. [0] [1] to [F] [F] corresponding to the parameter No. (Refer of section 4.4.1.)

The data No. is expressed in hexadecimal. The decimal equivalent of the data No. value corresponds to the parameter No.

(b) Return

The slave station returns the symbol of the parameter requested.

0	0	0								
---	---	---	--	--	--	--	--	--	--	--

Symbol characters (9 digits)

Part 8: Common Reference Material

(4) Reading the setting

The following shows how to read the parameter setting. Specify a parameter group in advance. (Refer to (1) of this section.)

(a) Transmission

Transmit the command [1] [5] and the data No. corresponding to the parameter No [0] [1] to [F] [F]. (Refer of section 4.4.1.)

The data No. is expressed in hexadecimal. The decimal equivalent of the data No. value corresponds to the parameter No.

(b) Return

The slave station returns the data and processing information of the parameter No. requested.

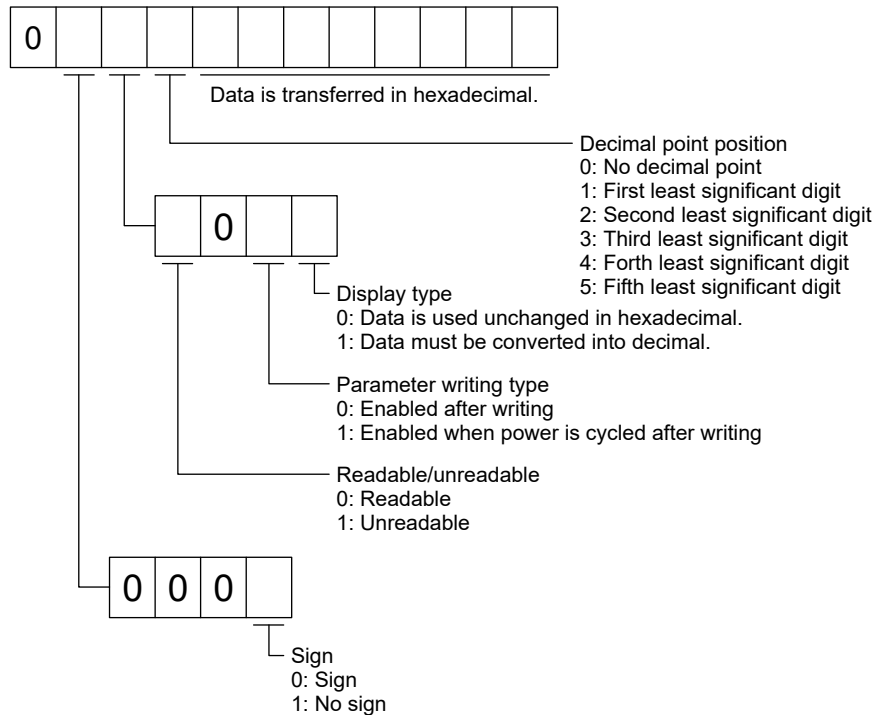

For example, data "00120000270F" means 999.9 (decimal display format) and data "000000003ABC" means 3ABC (hexadecimal display format).

When the display type is "0" (hexadecimal) and the decimal point position is other than 0, the display type is a special hexadecimal display format and "F" of the data value is handled as a blank. Data "0001FFFFF053" means 053 (special hexadecimal display format).

"000000000000" is transferred when the parameter that was read is the one inaccessible for reference in the parameter writing inhibit setting of [Pr. PA19].

Part 8: Common Reference Material

(5) Reading the setting range

The following shows how to read the parameter setting range. Specify a parameter group in advance. (Refer to (1) of this section.)

(a) Transmission

When reading an upper limit value, transmit the command [1] [6] and the data No. [0] [1] to [F] [F] corresponding to the parameter No. When reading a lower limit value, transmit the command [1] [7] and the data No. [0] [1] to [F] [F] corresponding to the parameter No. (Refer of section 4.4.1.)

The data No. is expressed in hexadecimal. The decimal equivalent of the data No. value corresponds to the parameter No.

(b) Return

The slave station returns the data and processing information of the parameter No. requested.

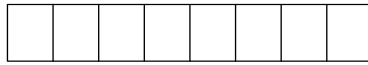

Data is transferred in hexadecimal.

For example, data "FFFFFFEC" means "-20".

Part 8: Common Reference Material

(6) Writing setting values

POINT
<p>● If setting values need to be changed with a high frequency (i.e. one time or more per one hour), write the setting values to the RAM, not the EEP-ROM. The EEPROM has a limitation in the number of write times and exceeding this limitation causes the servo amplifier to malfunction. Note that the number of write times to the EEP-ROM is limited to approximately 100,000.</p>

Write the parameter setting into EEP-ROM of the servo amplifier. Specify a parameter group in advance. (Refer to (1) of this section.)

Write any value within the setting enabled range. For the setting enabled range, refer to Part2/Part3 or read the setting range by performing operation in (4) of this section.

Transmit command [9] [4], the data No., and the set data.

The data No. is expressed in hexadecimal. The decimal equivalent of the data No. value corresponds to the parameter No.

When the data to be written is handled as decimal, the decimal point position must be specified. If it is not specified, the data cannot be written. When the data is handled as hexadecimal, specify "0" as the decimal point position.

Check the writing data is within the upper/lower limit value before writing. To prevent an error, read the parameter data to be written, confirm the decimal point position, and create transmission data.

On completion of writing, read the same parameter data to verify that data has been written correctly.

Command	Data No.	Data
[9] [4]	[0] [1] to [F] [F]	See below.



Data is transferred in hexadecimal.

Writing mode
 0: Writing to EEP-ROM
 3: Writing to RAM
 When the parameter data is changed frequently through communication, set "3" to the mode to change only the RAM data in the servo amplifier. When changing data frequently (once or more within one hour), do not write it to the EEP-ROM.

Decimal point position
 0: No decimal point
 1: First least significant digit
 2: Second least significant digit
 3: Third least significant digit
 4: Forth least significant digit
 5: Fifth least significant digit

Part 8: Common Reference Material

4.5.4 External I/O signal status (DIO diagnosis)

(1) Reading input device status

The following shows how to read the status of the input devices.

(a) Transmission

Transmit command [1] [2] and data No. [0] [0].

Command	Data No.
[1] [2]	[0] [0]

(b) Return

The slave station returns the status of the input devices.

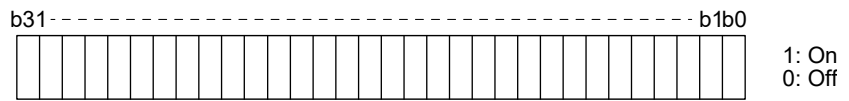

Command of each bit is transmitted to the master station as hexadecimal data.

Bit	Symbol
0	SON
1	LSP
2	LSN
3	TL
4	TL1
5	PC
6	RES
7	CR

Bit	Symbol
8	SP1
9	SP2
10	SP3
11	ST1/RS2
12	ST2/RS1
13	CM1
14	CM2
15	LOP

Bit	Symbol
16	
17	
18	
19	
20	STAB2
21	
22	
23	

Bit	Symbol
24	
25	
26	
27	CDP
28	
29	
30	
31	

(2) Reading external input pin status

The following shows how to read the on/off status of the external input pins.

(a) Transmission

Transmit command [1] [2] and data No. [4] [0].

Command	Data No.
[1] [2]	[4] [0]

(b) Return

The on/off status of the input pins are returned.

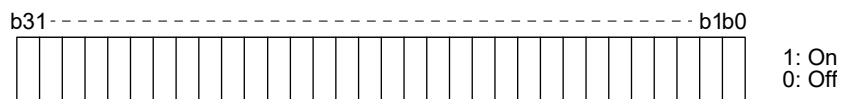

Command of each bit is transmitted to the master station as hexadecimal data.

Bit	CN1 connector pin
0	43
1	44
2	42
3	15
4	19
5	41
6	16
7	17

Bit	CN1 connector pin
8	18
9	45
10	
11	
12	
13	
14	
15	

Bit	CN1 connector pin
16	
17	
18	
19	
20	
21	
22	
23	

Bit	CN1 connector pin
24	
25	
26	
27	
28	
29	
30	
31	

Part 8: Common Reference Material

(3) Reading the status of input devices switched on with communication

The following shows how to read the on/off status of the input devices switched on with communication.

(a) Transmission

Transmit command [1] [2] and data No. [6] [0].

Command	Data No.
[1] [2]	[6] [0]

(b) Return

The slave station returns the status of the input devices.

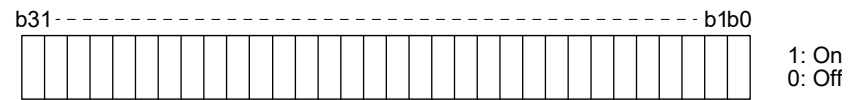

Command of each bit is transmitted to the master station as hexadecimal data.

Bit	Symbol
0	SON
1	LSP
2	LSN
3	TL
4	TL1
5	PC
6	RES
7	CR

Bit	Symbol
8	SP1
9	SP2
10	SP3
11	ST1/RS2
12	ST2/RS1
13	CM1
14	CM2
15	LOP

Bit	Symbol
16	
17	
18	
19	
20	STAB2
21	
22	
23	

Bit	Symbol
24	
25	
26	
27	CDP
28	
29	
30	
31	

(4) Reading external output pin status

The following shows how to read the on/off status of the external output pins.

(a) Transmission

Transmit command [1] [2] and data No. [C] [0].

Command	Data No.
[1] [2]	[C] [0]

Part 8: Common Reference Material

(b) Return

The slave station returns the status of the output devices.

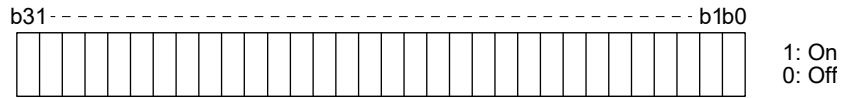

Command of each bit is transmitted to the master station as hexadecimal data.

Bit	CN1 connector pin
0	49
1	24
2	23
3	25
4	22
5	48
6	33
7	13 (Note)

Bit	CN1 connector pin
8	14 (Note)
9	
10	
11	
12	
13	
14	
15	

Bit	CN1 connector pin
16	
17	
18	
19	
20	
21	
22	
23	

Bit	CN1 connector pin
24	
25	
26	
27	
28	
29	
30	
31	

Note. This is available when devices are assigned to the CN1-13 pin and CN1-14 pin with MR-J4- _A_ -RJ 100 W or more servo amplifiers with software version B3 or later.

(5) Reading output device status

The following shows how to read the on/off status of the output devices.

(a) Transmission

Transmit command [1] [2] and data No. [8] [0].

Command	Data No.
[1] [2]	[8] [0]

(b) Return

The slave station returns the status of the input/output devices.

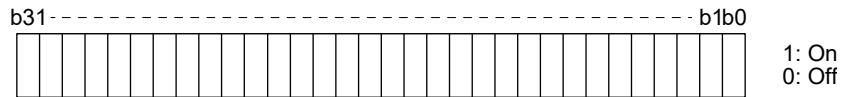

Command of each bit is transmitted to the master station as hexadecimal data.

Bit	Symbol
0	RD
1	SA
2	ZSP
3	TLC
4	VLC
5	INP
6	
7	WNG

Bit	Symbol
8	ALM
9	OP
10	MBR
11	DB
12	ACD0
13	ACD1
14	ACD2
15	BWNG

Bit	Symbol
16	
17	
18	
19	
20	
21	
22	
23	

Bit	Symbol
24	
25	CDPS
26	
27	ABSV
28	
29	
30	
31	

Part 8: Common Reference Material

4.5.5 Input device on/off

POINT	<p>● The on/off status of all devices in the servo amplifier are the status of the data received at last. Therefore, when there is a device which must be kept on, transmit data which turns the device on every time.</p>
--------------	--

Each input device can be switched on/off. However, when the device to be switched off is in the external input signal, also switch off the input signal.

Transmit command [9] [2], data No. [6] [0], and data.

Command	Data No.	Set data
[9] [2]	[6] [0]	See below.

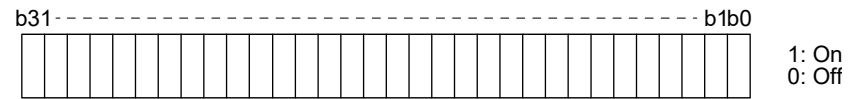

Command of each bit is transmitted to the master station as hexadecimal data.

Bit	Symbol
0	SON
1	LSP
2	LSN
3	TL
4	TL1
5	PC
6	RES
7	CR

Bit	Symbol
8	SP1
9	SP2
10	SP3
11	ST1/RS2
12	ST2/RS1
13	CM1
14	CM2
15	LOP

Bit	Symbol
16	
17	
18	
19	
20	STAB2
21	
22	
23	

Bit	Symbol
24	
25	
26	
27	CDP
28	
29	
30	
31	

Part 8: Common Reference Material

4.5.6 Disabling/enabling I/O devices (DIO)

You can disable inputs regardless of the I/O device status. When inputs are disabled, the input signals (devices) are recognized as follows. However, EM2 (Forced stop 2), LSP (Forward rotation stroke end), and LSN (Reverse rotation stroke end) cannot be disabled.

Signal	Status
Input device (DI)	Off
External analog input signal	0 V
Pulse train input	None

- (1) Disabling/enabling the input devices (DI), external analog input signals and pulse train inputs except EM2 (Forced stop 2), LSP (Forward rotation stroke end), and LSN (Reverse rotation stroke end). Transmit the following communication commands.

- (a) Disabling

Command	Data No.	Data
[9] [0]	[0] [0]	1EA5

- (b) Enabling

Command	Data No.	Data
[9] [0]	[1] [0]	1EA5

- (2) Disabling/enabling the output devices (DO)

Transmit the following communication commands.

- (a) Disabling

Command	Data No.	Data
[9] [0]	[0] [3]	1EA5

- (b) Enabling

Command	Data No.	Data
[9] [0]	[1] [3]	1EA5

Part 8: Common Reference Material

4.5.7 Input devices on/off (test operation)

Each input devices can be turned on/off for test operation. However, when the device to be switched off is in the external input signal, also switch off the input signal.

Transmit command [9] [2], data No. [0] [0], and data.

Command	Data No.	Set data
[9] [2]	[0] [0]	See below.

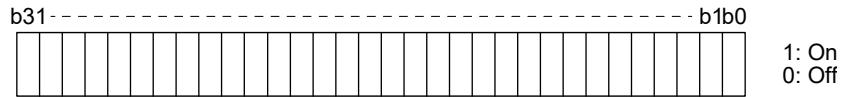

Command of each bit is transmitted to the master station as hexadecimal data.

Bit	Symbol
0	SON
1	LSP
2	LSN
3	TL
4	TL1
5	PC
6	RES
7	CR

Bit	Symbol
8	SP1
9	SP2
10	SP3
11	ST1
12	ST2
13	CM1
14	CM2
15	LOP

Bit	Symbol
16	
17	
18	
19	
20	STAB2
21	
22	
23	

Bit	Symbol
24	
25	
26	
27	CDP
28	
29	
30	
31	

Part 8: Common Reference Material

4.5.8 Test operation mode

POINT
<ul style="list-style-type: none"> ● The test operation mode is used to check operation. Do not use it for actual operation. ● If communication stops for longer than 0.5 s during test operation, the servo amplifier decelerates to a stop, resulting in servo-lock. To prevent this, continue communication all the time by monitoring the status display, etc. ● Even during operation, you can switch the servo amplifier to the test operation mode. In this case, switching to the test operation mode will shut off the base circuit to coast the motor.

(1) How to prepare and cancel the test operation mode

(a) Preparing the test operation mode

Set the test operation mode type with the following procedure.

1) Selection of test operation mode

Send the command [8] [B] + data No. [0] [0] + data to select the test operation mode.

Command	Data No.	Transmission data	Selection of test operation mode
[8] [B]	[0] [0]	0001	JOG operation
		0002	Positioning operation
		0004	Output signal (DO) forced output (Note)

Note Refer to section 4.5.9 for output signal (DO) forced output.

2) Check of test operation mode

Read the test operation mode set for the slave station, and check that it is set correctly.

a) Transmission

Transmit command [0] [0] and data No. [1] [2].

Command	Data No.
[0] [0]	[1] [2]

b) Reply

The slave station returns the preset operation mode.

0	0	0	
---	---	---	--

└ Test operation mode reading
 0: Normal mode (not test operation mode)
 1: JOG operation
 2: Positioning operation
 3: Motor-less operation
 4: Output signal (DO) forced output

(b) Cancel of test operation mode

To terminate the test operation mode, send the command [8] [B] + data No. [0] [0] + data.

Command	Data No.	Transmission data	Selection of test operation mode
[8] [B]	[0] [0]	0000	Test operation mode cancel

Part 8: Common Reference Material

(2) JOG operation

Transmit the command, data No., and data as follows to execute JOG operation.

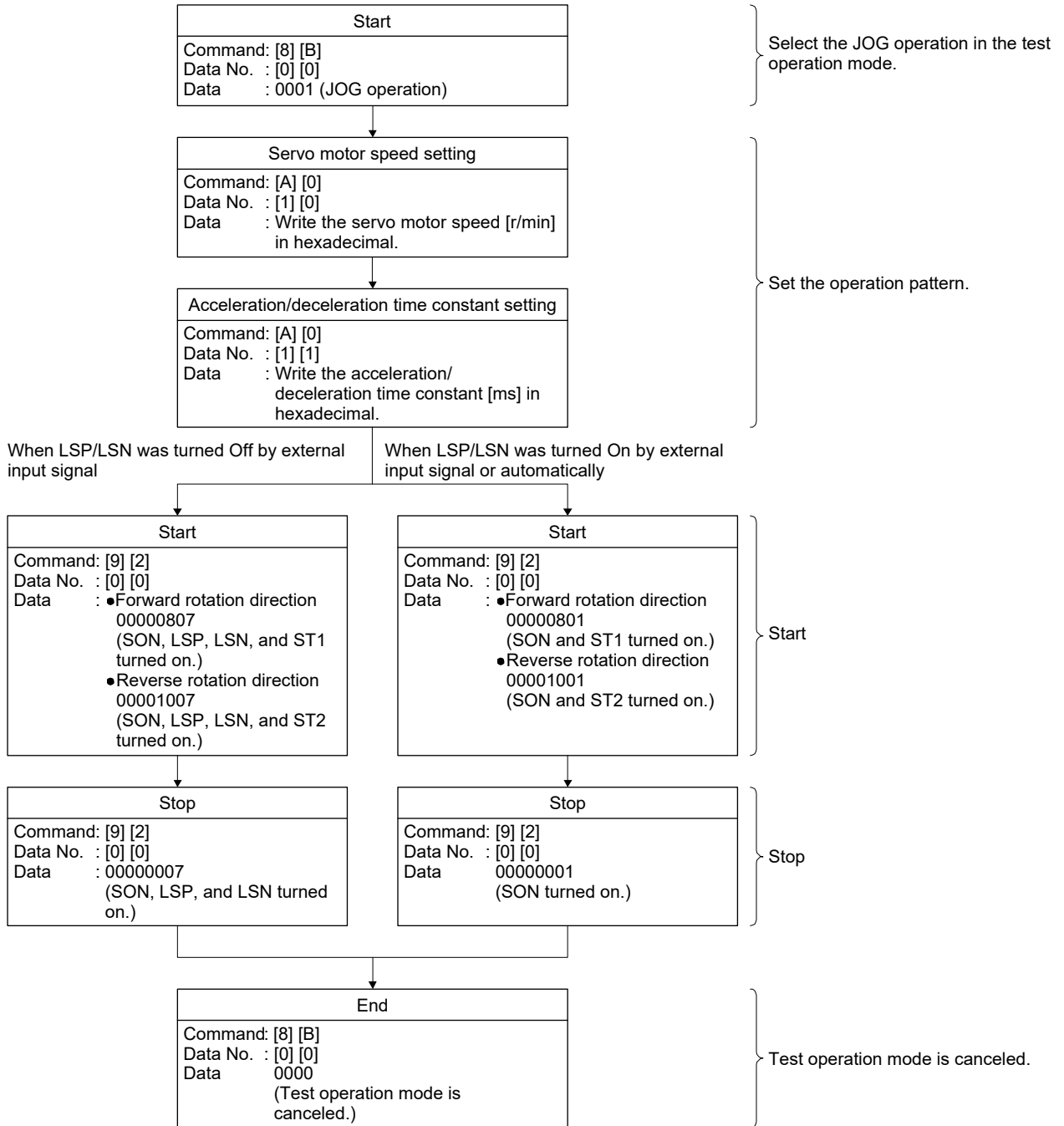

Part 8: Common Reference Material

(3) Positioning operation

(a) Operation procedure

Transmit the command, data No., and data as follows to execute positioning operation.

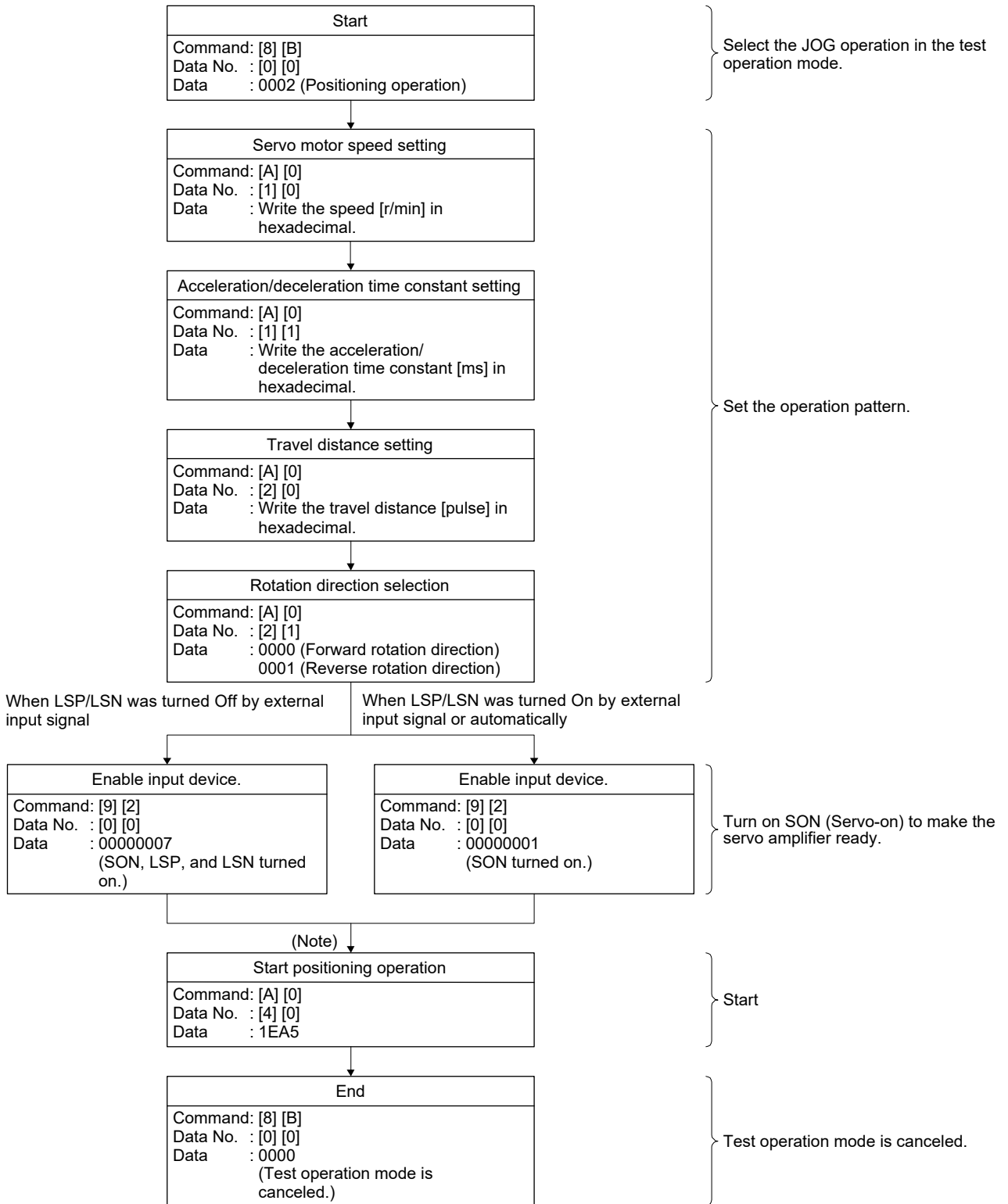

Note It has 100 ms delay.

Part 8: Common Reference Material

(b) Temporary stop/restart/remaining distance clear

Transmit the following command, data No., and data during positioning operation to make deceleration to a stop.

Command	Data No.	Data
[A] [0]	[4] [1]	STOP

Transmit the following command, data No., and data during a temporary stop to restart.

Command	Data No.	(Note) Data
[A] [0]	[4] [1]	GO__

Note "_" indicates a blank.

Transmit the following command, data No., and data during a temporary stop to stop positioning operation and erase the remaining travel distance.

Command	Data No.	(Note) Data
[A] [0]	[4] [1]	CLR_

Note "_" indicates a blank.

Part 8: Common Reference Material

4.5.9 Output signal pin on/off (output signal (DO) forced output)

In the test operation mode, the output signal pins can be turned on/off regardless of the servo status. Using command [9] [0], disable the external output signals in advance.

(1) Selecting output signal (DO) forced output in the test operation mode

Transmit command + [8] [B] + data No. [0] [0] + data "0004" to select output signal (DO) forced output.

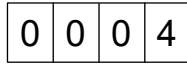

└ Selection of test operation mode
4: Output signal (DO) forced output

(2) External output signal on/off

Transmit the following communication commands.

Command	Data No.	Set data
[9] [2]	[A] [0]	See below.

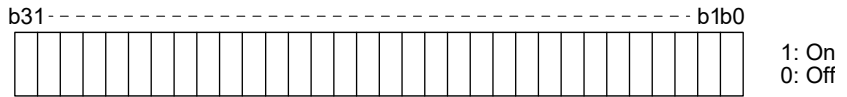

Command of each bit is transmitted to the master station as hexadecimal data.

Bit	CN1 connector pin
0	49
1	24
2	23
3	25
4	22
5	48
6	33
7	13 (Note)

Bit	CN1 connector pin
8	14 (Note)
9	
10	
11	
12	
13	
14	
15	

Bit	CN1 connector pin
16	
17	
18	
19	
20	
21	
22	
23	

Bit	CN1 connector pin
24	
25	
26	
27	
28	
29	
30	
31	

Note The MR-J4-_A_-RJ 100 W or more servo amplifier is available with software version B3 or later.

(3) Output signal (DO) forced output

Transmit command [8] [B] + data No. [0] [0] + data to stop output signal (DO) forced output.

Command	Data No.	Transmission data	Selection of test operation mode
[8] [B]	[0] [0]	0000	Test operation mode cancel

Part 8: Common Reference Material

4.5.10 Alarm history

(1) Alarm No. reading

The following shows how to read alarm Nos. which occurred in the past. Alarm Nos. and occurrence times of No. 0 (last alarm) to No. 15 (sixteenth alarm in the past) are read.

(a) Transmission

Transmit command [3] [3] + data No. [1] [0] to [1] [F]. Refer of section 4.4.1.

(b) Return

Alarm Nos. corresponding to the data No. is provided.

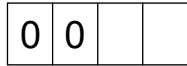

Alarm No. is transferred in hexadecimal

For example, "0032" means [AL. 32] and "00FF" means [AL. _ _] (no alarm).

(2) Alarm occurrence time reading

The following shows how to read alarm occurrence times which occurred in the past.

Alarm occurrence time corresponding to the data No. is provided in terms of the total time beginning with operation start, with the minute unit omitted.

(a) Transmission

Transmit command [3] [3] + data No. [2] [0] to [2] [F].

Refer of section 4.4.1.

(b) Return



The alarm occurrence time is transferred in hexadecimal.
Hexadecimal must be converted into decimal.

For example, data "01F5" means that the alarm occurred in 501 hours after starting operation.

(3) Clearing the alarm history

Alarm history is cleared.

Transmit command [8] [2] and data No. [2] [0].

Command	Data No.	Data
[8] [2]	[2] [0]	1EA5

Part 8: Common Reference Material

4.5.11 Current alarm

(1) Current alarm reading

The following shows how to read the alarm No. which is occurring currently.

(a) Transmission

Transmit command [0] [2] and data No. [0] [0].

Command	Data No.
[0] [2]	[0] [0]

(b) Return

The slave station returns the alarm currently occurring.

0	0		
---	---	--	--

Alarm No. is transferred in hexadecimal

For example, "0032" means [AL. 32] and "00FF" means [AL. _ _] (no alarm).

(2) Reading status display at alarm occurrence

The following shows how to read the status display data at alarm occurrence. When the data No. corresponding to the status display item is transmitted, the data value and data processing information will be returned.

(a) Transmission

Transmit the command [3] [5] + the data No. corresponding to the status display item to read, [8] [0] to [8] [E] and [A] [0] to [A] [9]. Refer of section 4.4.1.

(b) Return

The slave station returns the status display data of requested alarm at occurrence.

0	0																		
---	---	--	--	--	--	--	--	--	--	--	--	--	--	--	--	--	--	--	--

Data 32-bit length (hexadecimal representation)
(Data conversion is required as indicated in the display type.)

Display type

0: Data must be converted into decimal.

1: Data is used unchanged in hexadecimal.

Decimal point position

0: No decimal point

1: First least significant digit (normally not used)

2: Second least significant digit

3: Third least significant digit

4: Forth least significant digit

5: Fifth least significant digit

6: Sixth least significant digit

(3) Current alarm reset

As by the reset (RES) on, reset the servo amplifier alarm to make the servo amplifier ready to operate. After removing the cause of the alarm, reset the alarm with no command entered.

Command	Data No.	Data
[8] [2]	[0] [0]	1EA5

Part 8: Common Reference Material

4.5.12 Other commands

(1) Servo motor-side pulse unit absolute position

The following shows how to read the absolute position in the servo motor-side pulse unit. Note that overflow will occur in the position of 8192 or more revolutions from the home position.

(a) Transmission

Transmit command [0] [2] and data No. [9] [0].

Command	Data No.
[0] [2]	[9] [0]

(b) Return

The slave station returns the requested servo motor-side pulses.

--	--	--	--	--	--	--	--	--	--

Absolute position is sent back in hexadecimal in the servo motor-side pulse
(Data must be converted into decimal.)

For example, data "000186A0" is 100000 pulses in the motor-side pulse unit.

(2) Command unit absolute position

The following shows how to read the absolute position in the command unit.

(a) Transmission

Transmit command [0] [2] and data No. [9] [1].

Command	Data No.
[0] [2]	[9] [1]

(b) Return

The slave station returns the requested command pulses.

--	--	--	--	--	--	--	--	--	--

Absolute position is sent back in hexadecimal in the command unit.
(Data must be converted into decimal.)

For example, data "000186A0" is 100000 pulses in the command unit.

Part 8: Common Reference Material

(3) Software version

The following shows how to read the software version of the servo amplifier.

(a) Transmission

Transmit command [0] [2] and data No. [7] [0].

Command	Data No.
[0] [2]	[7] [0]

(b) Return

The slave station returns the requested software version.

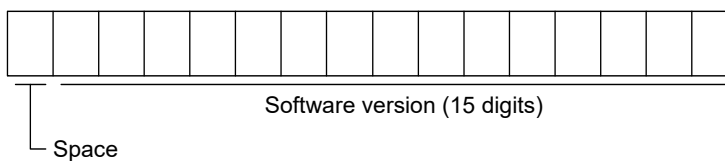

Part 8: Common Reference Material

5. HF-_P/HA-_P/HC-_P MOTOR DRIVE

5.1 MR-J3 series servo motors which are available with MR-J4-_A_ , MR-J4-_B_ and MR-J4-_GF_

POINT

- For the software version of the servo amplifier, refer to "3.1 Method for checking the software version".
- When you use a servo motor which is not supported, please contact your local sales office.
- When an MR-J4 series servo amplifier is used to drive the MR-J3 series servo motor, a regenerative option of either the existing MR-J3 series or MR-J4 series can be used. However, it is recommended to replace the existing regenerative option with the MR-J4 series regenerative option prior to the replacement with MR-J4 series servo motors. For details of the combinations of servo amplifiers and regenerative options, refer to "Chapter 1: COMPARISON TABLE OF REGENERATIVE OPTION COMBINATIONS" in "Part 10: Review on Replacement of Optional Peripheral Equipment".
The same applies when the MR-J4-_B_ servo amplifier is set to "J3 compatibility mode".
- Even when driving the MR-J3 series servo motor with the MR-J4 series servo amplifier, the detector resolution per rotation of the HF-_P/HC-_P/HA-_P servo motor is 18 bits (262144 pulses/rev).

Part 8: Common Reference Material

(1) 200 V class

The list for the servo motor/servo amplifier combination

Servo motor series	Servo motor model (Including servo motors with gear reducers/brakes)	Servo amplifier model (Note 1)	Servo amplifier software version		
			J4 mode	J3 compatibility mode	
HF-KP series	HF-KP053	MR-J4-10A(-RJ)	A8 or later	A8 or later	
		MR-J4-10B(-RJ)			
		MR-J4-10GF(-RJ)	A0 or later		
	HF-KP13	HF-KP13	MR-J4-10A(-RJ)	A8 or later	A8 or later
			MR-J4-10B(-RJ)		
			MR-J4-10GF(-RJ)	A0 or later	
	HF-KP23	HF-KP23	MR-J4-20A(-RJ)	A8 or later	A8 or later
			MR-J4-20B(-RJ)		
			MR-J4-20GF(-RJ)	A0 or later	
	HF-KP43	HF-KP43	MR-J4-40A(-RJ)	A8 or later	A8 or later
			MR-J4-40B(-RJ)		
			MR-J4-40GF(-RJ)	A0 or later	
HF-KP73	HF-KP73	MR-J4-70A(-RJ)	A8 or later	A8 or later	
		MR-J4-70B(-RJ)			
		MR-J4-70GF(-RJ)	A0 or later		
HF-MP series	HF-MP053	MR-J4-10A(-RJ)	A8 or later	A8 or later	
		MR-J4-10B(-RJ)			
		MR-J4-10GF(-RJ)	A0 or later		
	HF-MP13	HF-MP13	MR-J4-10A(-RJ)	A8 or later	A8 or later
			MR-J4-10B(-RJ)		
			MR-J4-10GF(-RJ)	A0 or later	
	HF-MP23	HF-MP23	MR-J4-20A(-RJ)	A8 or later	A8 or later
			MR-J4-20B(-RJ)		
			MR-J4-20GF(-RJ)	A0 or later	
	HF-MP43	HF-MP43	MR-J4-40A(-RJ)	A8 or later	A8 or later
			MR-J4-40B(-RJ)		
			MR-J4-40GF(-RJ)	A0 or later	
HF-MP73	HF-MP73	MR-J4-70A(-RJ)	A8 or later	A8 or later	
		MR-J4-70B(-RJ)			
		MR-J4-70GF(-RJ)	A0 or later		
HF-JP 1500 r/min series	HF-JP11K1M	MR-J4-11KA(-RJ)	D0 or later	D0 or later	
		MR-J4-11KB(-RJ)			
		MR-J4-11KGF(-RJ)	A0 or later		
	HF-JP15K1M	HF-JP15K1M	MR-J4-15KA(-RJ)	D0 or later	D0 or later
			MR-J4-15KB(-RJ)		
			MR-J4-15KGF(-RJ)	A0 or later	
HF-JP 3000 r/min series	HF-JP53	MR-J4-60A(-RJ)	A8 or later	D4 or later	
		MR-J4-60B(-RJ)			
		MR-J4-60GF(-RJ)	A0 or later		
		MR-J4-100A(-RJ) (Note 2)	Unsupported	Unsupported	
		MR-J4-100B(-RJ) (Note 2)			
		MR-J4-100GF(-RJ) (Note 2)			
	HF-JP73	HF-JP73	MR-J4-70A(-RJ)	A8 or later	D0 or later
			MR-J4-70B(-RJ)		
			MR-J4-70GF(-RJ)	A0 or later	
			MR-J4-200A(-RJ) (Note 2)	Unsupported	Unsupported
MR-J4-200B(-RJ) (Note 2)					
MR-J4-200GF(-RJ) (Note 2)					

Note 1. Not compatible with MR-J4- B_ -RJ020.

2. The combination when torque is increased.

Part 8: Common Reference Material

Servo motor series	Servo motor model (Including servo motors with gear reducers/brakes)	Servo amplifier model (Note 1)	Servo amplifier software version	
			J4 mode	J3 compatibility mode
HF-JP 3000 r/min series	HF-JP103	MR-J4-100A(-RJ)	A8 or later	D0 or later
		MR-J4-100B(-RJ)		
		MR-J4-100GF(-RJ)	A0 or later	
		MR-J4-200A(-RJ) (Note 2)	Unsupported	Unsupported
		MR-J4-200B(-RJ) (Note 2)		
		MR-J4-200GF(-RJ) (Note 2)		
	HF-JP153	MR-J4-200A(-RJ)	A8 or later	D0 or later
		MR-J4-200B(-RJ)		
		MR-J4-200GF(-RJ)	A0 or later	
		MR-J4-350A(-RJ) (Note 2)	Unsupported	Unsupported
		MR-J4-350B(-RJ) (Note 2)		
		MR-J4-350GF(-RJ) (Note 2)		
	HF-JP203	MR-J4-200A(-RJ)	A8 or later	D0 or later
		MR-J4-200B(-RJ)		
		MR-J4-200GF(-RJ)	A0 or later	
		MR-J4-350A(-RJ) (Note 2)	Unsupported	Unsupported
		MR-J4-350B(-RJ) (Note 2)		
		MR-J4-350GF(-RJ) (Note 2)		
	HF-JP353	MR-J4-350A(-RJ)	A8 or later	D4 or later
		MR-J4-350B(-RJ)		
		MR-J4-350GF(-RJ)	A0 or later	
		MR-J4-500A(-RJ) (Note 2)	Unsupported	Unsupported
		MR-J4-500B(-RJ) (Note 2)		
		MR-J4-500GF(-RJ) (Note 2)		
	HF-JP503	MR-J4-500A(-RJ)	A8 or later	D4 or later
		MR-J4-500B(-RJ)		
		MR-J4-500GF(-RJ)	A0 or later	
		MR-J4-700A(-RJ) (Note 2)	Unsupported	Unsupported
		MR-J4-700B(-RJ) (Note 2)		
		MR-J4-700GF(-RJ) (Note 2)		
HF-JP703	MR-J4-700A(-RJ)	A8 or later	D0 or later	
	MR-J4-700B(-RJ)			
	MR-J4-700GF(-RJ)	A0 or later		
HF-JP903	MR-J4-11KA(-RJ)	D4 or later	D4 or later	
	MR-J4-11KB(-RJ)			
	MR-J4-11KGF(-RJ)	A0 or later		

Note 1. Not compatible with MR-J4-_B_-RJ020.
 2. The combination when torque is increased.

Part 8: Common Reference Material

Servo motor series	Servo motor model (Including servo motors with gear reducers/brakes)	Servo amplifier model (Note)	Servo amplifier software version	
			J4 mode	J3 compatibility mode
HF-SP 1000 r/min series	HF-SP51	MR-J4-60A(-RJ)	A8 or later	
		MR-J4-60B(-RJ)		A8 or later
		MR-J4-60GF(-RJ)	A0 or later	
	HF-SP81	MR-J4-100A(-RJ)	A8 or later	
		MR-J4-100B(-RJ)		A8 or later
		MR-J4-100GF(-RJ)	A0 or later	
	HF-SP121	MR-J4-200A(-RJ)	A8 or later	
		MR-J4-200B(-RJ)		A8 or later
		MR-J4-200GF(-RJ)	A0 or later	
	HF-SP201	MR-J4-200A(-RJ)	A8 or later	
		MR-J4-200B(-RJ)		A8 or later
		MR-J4-200GF(-RJ)	A0 or later	
	HF-SP301	MR-J4-350A(-RJ)	A8 or later	
		MR-J4-350B(-RJ)		A8 or later
		MR-J4-350GF(-RJ)	A0 or later	
	HF-SP421	MR-J4-500A(-RJ)	A8 or later	
		MR-J4-500B(-RJ)		A8 or later
		MR-J4-500GF(-RJ)	A0 or later	
HF-SP 2000 r/min series	HF-SP52	MR-J4-60A(-RJ)	A8 or later	
		MR-J4-60B(-RJ)		A8 or later
		MR-J4-60GF(-RJ)	A0 or later	
	HF-SP102	MR-J4-100A(-RJ)	A8 or later	
		MR-J4-100B(-RJ)		A8 or later
		MR-J4-100GF(-RJ)	A0 or later	
	HF-SP152	MR-J4-200A(-RJ)	A8 or later	
		MR-J4-200B(-RJ)		A8 or later
		MR-J4-200GF(-RJ)	A0 or later	
	HF-SP202	MR-J4-200A(-RJ)	A8 or later	
		MR-J4-200B(-RJ)		A8 or later
		MR-J4-200GF(-RJ)	A0 or later	
	HF-SP352	MR-J4-350A(-RJ)	A8 or later	
		MR-J4-350B(-RJ)		A8 or later
		MR-J4-350GF(-RJ)	A0 or later	
	HF-SP502	MR-J4-500A(-RJ)	A8 or later	
		MR-J4-500B(-RJ)		A8 or later
		MR-J4-500GF(-RJ)	A0 or later	
HF-SP702	MR-J4-700A(-RJ)	A8 or later		
	MR-J4-700B(-RJ)		A8 or later	
	MR-J4-700GF(-RJ)	A0 or later		
HA-LP 1000 r/min series	HA-LP601	MR-J4-700A(-RJ)	A8 or later	
		MR-J4-700B(-RJ)		D0 or later
		MR-J4-700GF(-RJ)	A0 or later	
	HA-LP801	MR-J4-11KA(-RJ)	Unsupported	
		MR-J4-11KB(-RJ)		Unsupported
		MR-J4-11KGF(-RJ)		
	HA-LP12K1	MR-J4-11KA(-RJ)	D4 or later	
		MR-J4-11KB(-RJ)		D4 or later
		MR-J4-11KGF(-RJ)	A0 or later	
	HA-LP15K1	MR-J4-15KA(-RJ)	Unsupported	
		MR-J4-15KB(-RJ)		Unsupported
		MR-J4-15KGF(-RJ)		
HA-LP20K1	MR-J4-22KA(-RJ)	Unsupported		
	MR-J4-22KB(-RJ)		Unsupported	
	MR-J4-22KGF(-RJ)			

Note. Not compatible with MR-J4-_B_-RJ020.

Part 8: Common Reference Material

Servo motor series	Servo motor model (Including servo motors with gear reducers/brakes)	Servo amplifier model (Note)	Servo amplifier software version		
			J4 mode	J3 compatibility mode	
HA-LP 1000 r/min series	HA-LP25K1	MR-J4-22KA(-RJ)	Unsupported		
		MR-J4-22KB(-RJ)		Unsupported	
		MR-J4-22KGF(-RJ)			
	HA-LP30K1	MR-J4-DU30KA(-RJ)		Unsupported	
		MR-J4-DU30KB(-RJ)			
	HA-LP37K1	MR-J4-DU37KA(-RJ)		Unsupported	
	MR-J4-DU37KB(-RJ)				
HA-LP 1500 r/min series	HA-LP701M	MR-J4-700A(-RJ)	A8 or later		
		MR-J4-700B(-RJ)		D0 or later	
		MR-J4-700GF(-RJ)	A0 or later		
	HA-LP11K1M	MR-J4-11KA(-RJ)	D0 or later		
		MR-J4-11KB(-RJ)		D0 or later	
		MR-J4-11KGF(-RJ)	A0 or later		
	HA-LP15K1M	MR-J4-15KA(-RJ)	D0 or later		
		MR-J4-15KB(-RJ)		D0 or later	
		MR-J4-15KGF(-RJ)	A0 or later		
	HA-LP22K1M	MR-J4-22KA(-RJ)	D0 or later		
		MR-J4-22KB(-RJ)		D0 or later	
		MR-J4-22KGF(-RJ)	A0 or later		
	HA-LP30K1M	MR-J4-DU30KA(-RJ)	Unsupported	Unsupported	
		MR-J4-DU30KB(-RJ)			
	HA-LP37K1M	MR-J4-DU37KA(-RJ)	Unsupported	Unsupported	
		MR-J4-DU37KB(-RJ)			
	HA-LP 2000 r/min series	HA-LP502	MR-J4-500A(-RJ)	A8 or later	
			MR-J4-500B(-RJ)		D0 or later
MR-J4-500GF(-RJ)			A0 or later		
HA-LP702		MR-J4-700A(-RJ)	A8 or later		
		MR-J4-700B(-RJ)		D0 or later	
		MR-J4-700GF(-RJ)	A0 or later		
HA-LP11K2		MR-J4-11KA(-RJ)	D0 or later		
		MR-J4-11KB(-RJ)		D0 or later	
		MR-J4-11KGF(-RJ)	A0 or later		
HA-LP15K2		MR-J4-15KA(-RJ)	D0 or later		
		MR-J4-15KB(-RJ)		D0 or later	
		MR-J4-15KGF(-RJ)	A0 or later		
HA-LP22K2		MR-J4-22KA(-RJ)	D0 or later		
		MR-J4-22KB(-RJ)		D0 or later	
		MR-J4-22KGF(-RJ)	A0 or later		
HA-LP30K2		MR-J4-DU30KA(-RJ)	D0 or later		
		MR-J4-DU30KB(-RJ)		Unsupported	
HA-LP37K2		MR-J4-DU37KA(-RJ)	Unsupported	Unsupported	
		MR-J4-DU37KB(-RJ)			

Note. Not compatible with MR-J4-_B_-RJ020.

Part 8: Common Reference Material

Servo motor series	Servo motor model (Including servo motors with gear reducers/brakes)	Servo amplifier model (Note)	Servo amplifier software version	
			J4 mode	J3 compatibility mode
HC-UP series	HC-UP72	MR-J4-70A(-RJ)	A8 or later	D0 or later
		MR-J4-70B(-RJ)		
		MR-J4-70GF(-RJ)	A0 or later	
	HC-UP152	MR-J4-200A(-RJ)	A7 or later	D0 or later
		MR-J4-200B(-RJ)		
		MR-J4-200GF(-RJ)	A0 or later	
	HC-UP202	MR-J4-350A(-RJ)	A8 or later	D0 or later
		MR-J4-350B(-RJ)		
		MR-J4-350GF(-RJ)	A0 or later	
	HC-UP352	MR-J4-500A(-RJ)	A8 or later	D0 or later
		MR-J4-500B(-RJ)		
		MR-J4-500GF(-RJ)	A0 or later	
	HC-UP502	MR-J4-500A(-RJ)	A8 or later	D0 or later
		MR-J4-500B(-RJ)		
		MR-J4-500GF(-RJ)	A0 or later	
HC-LP series	HC-LP52	MR-J4-60A(-RJ)	A8 or later	D0 or later
		MR-J4-60B(-RJ)		
		MR-J4-60GF(-RJ)	A0 or later	
	HC-LP102	MR-J4-100A(-RJ)	A8 or later	D0 or later
		MR-J4-100B(-RJ)		
		MR-J4-100GF(-RJ)	A0 or later	
	HC-LP152	MR-J4-200A(-RJ)	A8 or later	D0 or later
		MR-J4-200B(-RJ)		
		MR-J4-200GF(-RJ)	A0 or later	
	HC-LP202	MR-J4-350A(-RJ)	A8 or later	D0 or later
		MR-J4-350B(-RJ)		
		MR-J4-350GF(-RJ)	A0 or later	
	HC-LP302	MR-J4-500A(-RJ)	A8 or later	D0 or later
		MR-J4-500B(-RJ)		
		MR-J4-500GF(-RJ)	A0 or later	
HC-RP series	HC-RP103	MR-J4-200A(-RJ)	A8 or later	D0 or later
		MR-J4-200B(-RJ)		
		MR-J4-200GF(-RJ)	A0 or later	
	HC-RP153	MR-J4-200A(-RJ)	A8 or later	D0 or later
		MR-J4-200B(-RJ)		
		MR-J4-200GF(-RJ)	A0 or later	
	HC-RP203	MR-J4-350A(-RJ)	A8 or later	D0 or later
		MR-J4-350B(-RJ)		
		MR-J4-350GF(-RJ)	A0 or later	
	HC-RP353	MR-J4-500A(-RJ)	A8 or later	D0 or later
		MR-J4-500B(-RJ)		
		MR-J4-500GF(-RJ)	A0 or later	
	HC-RP503	MR-J4-500A(-RJ)	A8 or later	D0 or later
		MR-J4-500B(-RJ)		
		MR-J4-500GF(-RJ)	A0 or later	

Note. Not compatible with MR-J4-_B_-RJ020.

Part 8: Common Reference Material

(2) 400 V class

The list for the servo motor/servo amplifier combination

Servo motor series	Servo motor model	Servo amplifier model (Note 1)	Servo amplifier software version		
			J4 mode	J3 compatibility mode	
HF-JP 1500 r/min series	HF-JP11K1M4	MR-J4-11KA4(-RJ)	D4 or later	D4 or later	
		MR-J4-11KB4(-RJ)			
		MR-J4-11KGF4(-RJ)	A0 or later		
	HF-JP15K1M4	HF-JP15K1M4	MR-J4-15KA4(-RJ)	D4 or later	D4 or later
			MR-J4-15KB4(-RJ)		
			MR-J4-15KGF4(-RJ)	A0 or later	
HF-JP 3000 r/min series	HF-JP534	MR-J4-60A4(-RJ)	D0 or later	D0 or later	
		MR-J4-60B4(-RJ)			
		MR-J4-60GF4(-RJ)	A0 or later		
		MR-J4-100A4(-RJ) (Note 2)	Unsupported	Unsupported	
		MR-J4-100B4(-RJ) (Note 2)			
		MR-J4-100GF4(-RJ) (Note 2)			
	HF-JP734	HF-JP734	MR-J4-100A4(-RJ)	D0 or later	D0 or later
			MR-J4-100B4(-RJ)		
			MR-J4-100GF4(-RJ)	A0 or later	
			MR-J4-200A4(-RJ) (Note 2)	Unsupported	Unsupported
			MR-J4-200B4(-RJ) (Note 2)		
			MR-J4-200GF4(-RJ) (Note 2)		
	HF-JP1034	HF-JP1034	MR-J4-100A4(-RJ)	D4 or later	D4 or later
			MR-J4-100B4(-RJ)		
			MR-J4-100GF4(-RJ)	A0 or later	
			MR-J4-200A4(-RJ) (Note 2)	Unsupported	Unsupported
			MR-J4-200B4(-RJ) (Note 2)		
			MR-J4-200GF4(-RJ) (Note 2)		
	HF-JP1534	HF-JP1534	MR-J4-200A4(-RJ)	D0 or later	D0 or later
			MR-J4-200B4(-RJ)		
			MR-J4-200GF4(-RJ)	A0 or later	
			MR-J4-350A4(-RJ) (Note 2)	Unsupported	Unsupported
			MR-J4-350B4(-RJ) (Note 2)		
			MR-J4-350GF4(-RJ) (Note 2)		
	HF-JP2034	HF-JP2034	MR-J4-200A4(-RJ)	D0 or later	D0 or later
			MR-J4-200B4(-RJ)		
			MR-J4-200GF4(-RJ)	A0 or later	
			MR-J4-350A4(-RJ) (Note 2)	Unsupported	Unsupported
			MR-J4-350B4(-RJ) (Note 2)		
			MR-J4-350GF4(-RJ) (Note 2)		
	HF-JP3534	HF-JP3534	MR-J4-350A4(-RJ)	D0 or later	D0 or later
			MR-J4-350B4(-RJ)		
			MR-J4-350GF4(-RJ)	A0 or later	
			MR-J4-500A4(-RJ) (Note 2)	Unsupported	Unsupported
			MR-J4-500B4(-RJ) (Note 2)		
			MR-J4-500GF4(-RJ) (Note 2)		
	HF-JP5034	HF-JP5034	MR-J4-500A4(-RJ)	D0 or later	D0 or later
			MR-J4-500B4(-RJ)		
			MR-J4-500GF4(-RJ)	A0 or later	
			MR-J4-700A4(-RJ) (Note 2)	Unsupported	Unsupported
			MR-J4-700B4(-RJ) (Note 2)		
			MR-J4-700GF4(-RJ) (Note 2)		
	HF-JP7034	HF-JP7034	MR-J4-700A4(-RJ)	D0 or later	D0 or later
			MR-J4-700B4(-RJ)		
			MR-J4-700GF4(-RJ)	A0 or later	
	HF-JP9034	HF-JP9034	MR-J4-11KA4(-RJ)	D4 or later	D4 or later
			MR-J4-11KB4(-RJ)		
			MR-J4-11KGF4(-RJ)	A0 or later	

Note 1. Not compatible with MR-J4-_B_(-RJ)020.

2. The combination when torque is increased.

Part 8: Common Reference Material

Servo motor series	Servo motor model	Servo amplifier model (Note)	Servo amplifier software version		
			J4 mode	J3 compatibility mode	
HF-SP 2000 r/min series	HF-SP524	MR-J4-60A4(-RJ)	D0 or later	D0 or later	
		MR-J4-60B4(-RJ)			
		MR-J4-60GF4(-RJ)	A0 or later		
	HF-SP1024	MR-J4-100A4(-RJ)	D0 or later	D0 or later	
		MR-J4-100B4(-RJ)			
		MR-J4-100GF4(-RJ)	A0 or later		
	HF-SP1524	MR-J4-200A4(-RJ)	D0 or later	D0 or later	
		MR-J4-200B4(-RJ)			
		MR-J4-200GF4(-RJ)	A0 or later		
	HF-SP2024	MR-J4-200A4(-RJ)	D0 or later	D0 or later	
		MR-J4-200B4(-RJ)			
		MR-J4-200GF4(-RJ)	A0 or later		
	HF-SP3524	MR-J4-350A4(-RJ)	D0 or later	D0 or later	
		MR-J4-350B4(-RJ)			
		MR-J4-350GF4(-RJ)	A0 or later		
	HF-SP5024	MR-J4-500A4(-RJ)	D0 or later	D0 or later	
		MR-J4-500B4(-RJ)			
		MR-J4-500GF4(-RJ)	A0 or later		
	HF-SP7024	MR-J4-700A4(-RJ)	D0 or later	D0 or later	
		MR-J4-700B4(-RJ)			
		MR-J4-700GF4(-RJ)	A0 or later		
	HA-LP 1000 r/min series	HA-LP6014	MR-J4-700A4(-RJ)	D0 or later	D0 or later
			MR-J4-700B4(-RJ)		
			MR-J4-700GF4(-RJ)	A0 or later	
HA-LP8014		MR-J4-11KA4(-RJ)	D4 or later	D4 or later	
		MR-J4-11KB4(-RJ)			
		MR-J4-11KGF4(-RJ)	A0 or later		
HA-LP12K14		MR-J4-11KA4(-RJ)	D4 or later	D4 or later	
		MR-J4-11KB4(-RJ)			
		MR-J4-11KGF4(-RJ)	A0 or later		
HA-LP15K14		MR-J4-15KA4(-RJ)	D0 or later	D0 or later	
		MR-J4-15KB4(-RJ)			
		MR-J4-15KGF4(-RJ)	A0 or later		
HA-LP20K14		MR-J4-22KA4(-RJ)	D4 or later	D4 or later	
		MR-J4-22KB4(-RJ)			
		MR-J4-22KGF4(-RJ)	A0 or later		
HA-LP25K14		MR-J4-DU30KA4(-RJ)	Unsupported	Unsupported	
		MR-J4-DU30KB4(-RJ)		Unsupported	
HA-LP30K14		MR-J4-DU30KA4(-RJ)	Unsupported	Unsupported	
		MR-J4-DU30KB4(-RJ)		Unsupported	
HA-LP37K14		MR-J4-DU37KA4(-RJ)	Unsupported	Unsupported	
		MR-J4-DU37KB4(-RJ)		Unsupported	

Note. Not compatible with MR-J4-_B_-RJ020.

Part 8: Common Reference Material

Servo motor series	Servo motor model	Servo amplifier model (Note)	Servo amplifier software version		
			J4 mode	J3 compatibility mode	
HA-LP 1500 r/min series	HA-LP701M4	MR-J4-700A4(-RJ)	D0 or later		
		MR-J4-700B4(-RJ)		D0 or later	
		MR-J4-700GF4(-RJ)	A0 or later		
	HA-LP11K1M4	MR-J4-11KA4(-RJ)	D0 or later		
		MR-J4-11KB4(-RJ)		D0 or later	
		MR-J4-11KGF4(-RJ)	A0 or later		
	HA-LP15K1M4	MR-J4-15KA4(-RJ)	D0 or later		
		MR-J4-15KB4(-RJ)		D0 or later	
		MR-J4-15KGF4(-RJ)	A0 or later		
	HA-LP22K1M4	MR-J4-22KA4(-RJ)	D0 or later		
		MR-J4-22KB4(-RJ)		D0 or later	
		MR-J4-22KGF4(-RJ)	A0 or later		
	HA-LP30K1M4	MR-J4-DU30KA4(-RJ)	Unsupported		
		MR-J4-DU30KB4(-RJ)		Unsupported	
	HA-LP37K1M4	MR-J4-DU37KA4(-RJ)			
		MR-J4-DU37KB4(-RJ)		Unsupported	
	HA-LP45K1M4	MR-J4-DU45KA4(-RJ)			
		MR-J4-DU45KB4(-RJ)		Unsupported	
HA-LP50K1M4	MR-J4-DU55KA4(-RJ)				
	MR-J4-DU55KB4(-RJ)	Unsupported			
HA-LP 2000 r/min series	HA-LP11K24	MR-J4-11KA4(-RJ)		D0 or later	
		MR-J4-11KB4(-RJ)			D0 or later
		MR-J4-11KGF4(-RJ)	A0 or later		
	HA-LP15K24	MR-J4-15KA4(-RJ)	D0 or later		
		MR-J4-15KB4(-RJ)		D0 or later	
		MR-J4-15KGF4(-RJ)	A0 or later		
	HA-LP22K24	MR-J4-22KA4(-RJ)	D0 or later		
		MR-J4-22KB4(-RJ)		D0 or later	
		MR-J4-22KGF4(-RJ)	A0 or later		
	HA-LP30K24	MR-J4-DU30KA4(-RJ)	D4 or later		
		MR-J4-DU30KB4(-RJ)		D4 or later	
	HA-LP37K24	MR-J4-DU37KA4(-RJ)			
		MR-J4-DU37KB4(-RJ)		D4 or later	
	HA-LP45K24	MR-J4-DU45KA4(-RJ)			
		MR-J4-DU45KB4(-RJ)		D4 or later	
	HA-LP55K24	MR-J4-DU55KA4(-RJ)			
		MR-J4-DU55KB4(-RJ)		D4 or later	

Note. Not compatible with MR-J4-_B_-RJ020.

Part 8: Common Reference Material

(3) 100 V class

The list for the servo motor/servo amplifier combination

Servo motor series	Servo motor model	Servo amplifier model (Note)	Servo amplifier software version	
			J4 mode	J3 compatibility mode
HF-KP series	HF-KP053	MR-J4-10A1(-RJ)	D0 or later	D0 or later
		MR-J4-10B1(-RJ)		
		MR-J4-10GF1(-RJ)		
	HF-KP13	MR-J4-10A1(-RJ)	D0 or later	D0 or later
		MR-J4-10B1(-RJ)		
		MR-J4-10GF1(-RJ)		
	HF-KP23	MR-J4-20A1(-RJ)	D0 or later	D0 or later
		MR-J4-20B1(-RJ)		
		MR-J4-20GF1(-RJ)		
	HF-KP43	MR-J4-40A1(-RJ)	D0 or later	D0 or later
		MR-J4-40B1(-RJ)		
		MR-J4-40GF1(-RJ)		
HF-MP series	HF-MP053	MR-J4-10A1(-RJ)	D0 or later	D0 or later
		MR-J4-10B1(-RJ)		
		MR-J4-10GF1(-RJ)		
	HF-MP13	MR-J4-10A1(-RJ)	D0 or later	D0 or later
		MR-J4-10B1(-RJ)		
		MR-J4-10GF1(-RJ)		
	HF-MP23	MR-J4-20A1(-RJ)	D0 or later	D0 or later
		MR-J4-20B1(-RJ)		
		MR-J4-20GF1(-RJ)		
	HF-MP43	MR-J4-40A1(-RJ)	D0 or later	D0 or later
		MR-J4-40B1(-RJ)		
		MR-J4-40GF1(-RJ)		

Note. Not compatible with MR-J4-_B_-RJ020.

Part 8: Common Reference Material

5.2 MR-J3 series servo motors which are available with MR-J4W_-_B

POINT
<ul style="list-style-type: none">● For the software version of the servo amplifier, refer to "3.1 Method for checking the software version".● When you use a servo motor which is not supported, please contact your local sales office.● When an MR-J4W_-_B servo amplifier is used to drive the MR-J3 series servo motor, a regenerative option of either the existing MR-J3W series or MR-J4 series can be used. However, it is recommended to replace the existing regenerative option with the MR-J4 series regenerative option prior to the replacement with MR-J4 series servo motors. For details of the combinations of servo amplifiers and regenerative options, refer to "Chapter 1: COMPARISON TABLE OF REGENERATIVE OPTION COMBINATIONS" in "Part 10: Review on Replacement of Optional Peripheral Equipment". The same applies when the MR-J4W_-_B servo amplifier is set to "J3 compatibility mode".● Even when driving the MR-J3 series servo motor with the MR-J4W_-_B servo amplifier, the detector resolution per rotation of the HF-_P/HC-_P/HA-_P servo motor is 18 bits (262144 pulses/rev).

Part 8: Common Reference Material

(1) 200 V class

The list for the servo motor/servo amplifier combination

Servo motor series	Servo motor model	Servo amplifier model	Servo amplifier software version	
			J4 mode	J3 compatibility mode
HF-KP series	HF-KP053	MR-J4W2-22B	D0 or later	D0 or later
		MR-J4W3-222B (Note)		
		MR-J4W2-44B		
		MR-J4W3-444B (Note)		
	HF-KP13	MR-J4W2-22B		
		MR-J4W3-222B (Note)		
		MR-J4W2-44B		
		MR-J4W3-444B (Note)		
	HF-KP23	MR-J4W2-22B		
		MR-J4W3-222B (Note)		
		MR-J4W2-44B		
		MR-J4W3-444B (Note)		
	HF-KP43	MR-J4W2-44B		
		MR-J4W3-444B (Note)		
		MR-J4W2-77B		
		MR-J4W2-1010B		
HF-KP73	MR-J4W2-77B			
	MR-J4W2-1010B			
HF-MP series	HF-MP053	MR-J4W2-22B	D0 or later	D0 or later
		MR-J4W3-222B (Note)		
		MR-J4W2-44B		
		MR-J4W3-444B (Note)		
	HF-MP13	MR-J4W2-22B		
		MR-J4W3-222B (Note)		
		MR-J4W2-44B		
		MR-J4W3-444B (Note)		
	HF-MP23	MR-J4W2-22B		
		MR-J4W3-222B (Note)		
		MR-J4W2-44B		
		MR-J4W3-444B (Note)		
	HF-MP43	MR-J4W2-44B		
		MR-J4W3-444B (Note)		
		MR-J4W2-77B		
		MR-J4W2-1010B		
HF-MP73	MR-J4W2-77B			
	MR-J4W2-1010B			
HF-JP 3000 r/min series	HF-JP53	MR-J4W2-77B	Unsupported	Unsupported
		MR-J4W2-1010B		
	HF-JP73	MR-J4W2-77B		
	HF-JP103	MR-J4W2-1010B		
HF-SP 1000 r/min series	HF-SP51	MR-J4W2-77B	D0 or later	D0 or later
		MR-J4W2-1010B		
	HF-SP81	MR-J4W2-1010B		
HF-SP 2000 r/min series	HF-SP52	MR-J4W2-77B	D0 or later	D0 or later
		MR-J4W2-1010B		
	HF-SP102	MR-J4W2-1010B		
HC-UP series	HC-UP72	MR-J4W2-77B	Unsupported	Unsupported
		MR-J4W2-1010B		
HC-LP series	HC-LP52	MR-J4W2-77B	Unsupported	Unsupported
		MR-J4W2-1010B		
	HC-LP102	MR-J4W2-1010B		

Note. One servo amplifier can drive three axis servo motors.

Part 8: Common Reference Material

6. APPLICATION OF FUNCTIONS

This chapter explains application of using servo amplifier functions.

POINT
<ul style="list-style-type: none"> ● The J3 compatibility mode is compatible only with MR-J4-_B_(-RJ) and MR-J4W2-_B_ servo amplifiers.

6.1 J3 compatibility mode

POINT
<ul style="list-style-type: none"> ● J3 series servo motor driving in the J3 compatibility mode will be sequentially available. For the target models and schedule, contact your local sales office. ● Specifications of the J3 compatibility mode of the servo amplifier with software version A4 or earlier differ from those with software version A5 or later. For details, refer to section 6.1.8. ● The J3 compatibility mode is not compatible with the master-slave operation function. ● The fully closed loop control in the J3 compatibility mode is available for the servo amplifiers with software version A3 or later.

6.1.1 J3 Outline of J3 compatibility mode

MR-J4-_B_(-RJ) servo amplifiers and MR-J4W2-_B_ have two operation modes. "J4 mode" is for using all functions with full performance and "J3 compatibility mode" is compatible with MR-J3-_B_ series for using the amplifiers as the conventional series.

When you connect an amplifier with SSCNET III/H communication for the first controller communication by factory setting, the operation mode will be fixed to "J4 mode". For SSCNET communication, it will be fixed to "J3 compatibility mode". When you set the mode back to the factory setting, use the application "MR Mode Change".

The application "MR Mode Change" is packed with MR Configurator2 of software version 1.12N or later. For the operating conditions of the application "MR Mode Change", use MR Configurator2.

6.1.2 Operation modes supported by J3 compatibility mode

The J3 compatibility mode supports the following operation modes.

Operation mode in J3 compatibility mode	Model of MR-J3-_B_	Model of MR-J3W-_B_
MR-J3-B standard control mode (rotary servo motor)	MR-J3-_B_	MR-J3W-_B_

Each operation mode has the same ordering as conventional MR-J3-B series servo amplifiers and is compatible with their settings.

In addition, the control response characteristic in the J3 compatibility mode will be the same as that of MR-J3 series. By enabling the J3 extension function, control response will be equal to MR-J4 series using a controller compatible with SSCNET III.

Part 8: Common Reference Material

6.1.3 J3 compatibility mode supported function list

The following shows functions which compatible with J4 mode and J3 compatibility mode. The letters such as "A0" described after ◎ and ○ mean servo amplifier software versions which compatible with each function. Each function is used with servo amplifiers with these software versions or later.

Function	Name	Compatibility (◎: J4 new, ○: Equivalent to J3, ×: Not available)		
		MR-J4 series		MR-J3/MR-J3W series (Note 8)
		J4 mode	J3 compatibility mode	
Basic specification	Speed frequency response	2.5 kHz	2.1 kHz	2.1 kHz
	Encoder resolution	22 bits (Note 1)	18 bits (Note 1)	18 bits
SSCNET III/H communication or SSCNET III communication	Communication baud rate	150 Mbps	50 Mbps	50 Mbps
	Maximum distance between stations	100 m	50 m	50 m
Basic function	Absolute position detection system	○ A0	○ A0	○
	Fully closed loop control (Note 9)	○ A3 (Two-wire type only) (Note 13)	○ A3 (Two-wire type only) (Note 13)	MR-J3-_B-RJ006 MR-J3-_S
	Linear servo motor driving	○ A0 (Two-wire type/ four-wire type only) (Note 13)	○ A0 (Two-wire type/ four-wire type only) (Note 13)	MR-J3-_B-RJ004 MR-J3W-_B
	Direct drive motor driving	○ A0	○ A0	MR-J3-_B-RJ080W MR-J3W-_B
	Motor-less operation	○ A0 (Note 2)	○ A0 (Note 2)	○
	Rotation direction selection/travel direction selection	○ A0	○ A0	○
Encoder output pulses	A/B-phase pulse output	○ A0 (Note 3)	○ A0 (Note 3)	○
	Z-phase pulse output	○ A0 (Note 4)	○ A0 (Note 4)	○ (Note 4)
Input/output	Analog monitor output	○ A0 (Note 5)	○ A0 (Note 5)	○
	Motor thermistor	○ A0	○ A0	MR-J3-_B-RJ004 MR-J3-_B-RJ080W MR-J3W-_B
Control mode	Position control mode	○ A0	○ A0	○
	Speed control mode	○ A0	○ A0	○
	Torque control mode	○ A0	○ A0	○
	Continuous operation to torque control mode	○ A0	○ A0	○
Auto tuning	Auto tuning mode 1	○ A0	○ A0	○
	Auto tuning mode 2	○ A0	○ A0	○
	2 gain adjustment mode 1 (interpolation mode)	○ A0	○ A0	○
	2 gain adjustment mode 2	◎ A0	×	×
	Manual mode	○ A0	○ A0	○
Filter function	Machine resonance suppression filter 1	○ A0	○ A0	○
	Machine resonance suppression filter 2	○ A0	○ A0	○
	Machine resonance suppression filter 3	◎ A0	◎ B0 (Note 15)	×
	Machine resonance suppression filter 4	◎ A0	◎ B0 (Note 15)	×
	Machine resonance suppression filter 5	◎ A0	◎ B0 (Note 15)	×
	Shaft resonance suppression filter	○ A0	◎ B0 (Note 15)	×
	Low-pass filter	○ A0	○ A0	○
	Robust disturbance compensation (Note 10)	×	○ A0	○
	Robust filter	◎ A0	◎ B0 (Note 15)	×

Part 8: Common Reference Material

Function	Name	Compatibility (◎: J4 new, ○: Equivalent to J3, ×: Not available)		
		MR-J4 series		MR-J3/MR-J3W series (Note 8)
		J4 mode	J3 compatibility mode	
Vibration suppression control	Standard mode/3 inertia mode	◎ A0	◎ B0 (Note 15)	×
	Vibration suppression control 1	○ A0	○ A0	○
	Vibration suppression control 2	◎ A0	◎ B0 (Note 15)	×
	Command notch filter	○ A0	○ A0	○
Applied control	Gain switching	○ A0	○ A0	○
	Slight vibration suppression control	○ A0	○ A0	○
	Overshoot amount compensation	○ A0	○ A0	○
	PI-PID switching control	○ A0	○ A0	○
	Feed forward	○ A0	○ A0	○
	Torque limit	○ A0	○ A0	○
	Master-slave operation function	○ A8 (Note 5)	×	○
	Scale measurement function	◎ A8 (Note 3)	×	×
	Model adaptive control disabled	○ B4	○ B4	×
	Lost motion compensation function	◎ B4 (Note 5)	◎ (Note 5, 15)	×
	Super trace control	◎ B4 (Note 5)	×	×
Adjustment function	One-touch tuning	◎ A0	◎ B0 (Note 15)	×
	Adaptive tuning	○ A0	○ A0	○
	Vibration suppression control 1 tuning	○ A0	○ A0	○
	Vibration suppression control 2 tuning	◎ A0	◎ B0 (Note 15)	×
Fully closed loop control	Fully closed loop electronic gear	○ A3	○ A3	MR-J3- S MR-J3- B-RJ006
	Dual feedback control	○ A3	○ A3	
	Semi closed/fully closed switching loop control	○ A3	○ A3	
	Fully closed loop control error detection function	○ A3	○ A3	
Linear compatible	Linear servo control error detection function	○ A0	○ A0	MR-J3- B-RJ004 MR-J3W- B
	Servo motor series/types setting function	○ A0	○ A0	
Magnetic pole detection	Direct current exciting method magnetic pole detection	○ A0	○ A0	MR-J3- B-RJ004 MR-J3- B-RJ080W MR-J3W- B
	Current detection method magnetic pole detection	× (Note 6)	○ A0	MR-J3- B-RJ004 MR-J3W- B
	Minute position detection method magnetic pole detection	○ A0	○ A0	MR-J3- B-RJ004 MR-J3- B-RJ080W MR-J3W- B
	Initial magnetic pole detection error detection function	○ A0	○ A0	MR-J3- B-RJ004 MR-J3- B-RJ080W MR-J3W- B
Encoder	Semi closed loop control two-wire type/four-wire type selection	○ A0	○ A0	○
	Serial interface compatible linear encoder	○ A0	○ A0	MR-J3- S MR-J3- B-RJ006 MR-J3- B-RJ004 MR-J3W- B
	Pulse train interface (A/B/Z-phase differential output type) compatible linear encoder	○ A5 (Note 14)	○ A5 (Note 14)	MR-J3- S MR-J3- B-RJ006 MR-J3- B-RJ004
Functional safety	STO function	○ A0	○ A0	MR-J3- S
	Forced stop deceleration function at alarm occurrence	○ A0	○ A0 (Note 12)	MR-J3- S
	Vertical axis freefall prevention function	○ A0	○ A0	MR-J3- S
Tough drive function	SEMI-F47 function	◎ A0	◎ B0 (Note 15, 16)	×
	Vibration tough drive	◎ A0	◎ B0 (Note 15)	×
	Instantaneous power failure tough drive	◎ A0	◎ B0 (Note 15)	×
Diagnosis function	3-digit alarm display	◎ A0	◎ A0	MR-J3W- B
	16 alarm histories supported	◎ A0	×	× (Note 7)
	Drive recorder function	◎ A0	◎ B0 (Note 15)	×
	Machine diagnosis function	◎ A0	◎ B0 (Note 15)	×

Part 8: Common Reference Material

Function	Name	Compatibility (◎: J4 new, ○: Equivalent to J3, ×: Not available)		
		MR-J4 series		MR-J3/MR-J3W series (Note 8)
		J4 mode	J3 compatibility mode	
Controller	SSCNET III	×	○ A0	○
	SSCNET III/H	◎ A0	×	×
	Home position return function	○ A0	○ A0	○
Others	J4 mode/J3 compatibility mode automatic identification (Note 11)	○ A0	○ A0	×
	Power monitoring function	◎ A0	◎ B0 (Note 15)	×

Note 1. The value is at the HG series servo motor driving.

2. The motor-less operation cannot be used in the fully closed loop control mode, linear servo motor control mode, or DD motor control mode.
3. It is not available with MR-J4W3-_B servo amplifiers.
4. It is not available with the MR-J3W-_B, MR-J4W2-_B, and MR-J4W3-_B servo amplifiers.
5. It is not available with the MR-J4W2-_B and MR-J4W3-_B servo amplifiers.
6. The minute position detection method is available instead.
7. Alarm history will be saved up to six times.
8. The functions of the product with modified parts (GA) in the MR-J3-_B servo amplifiers are all covered by the J3 compatibility mode of the MR-J4-_B servo amplifiers.
9. MR-J4W3-_B servo amplifiers do not support the fully closed loop control system.
10. For MR-J4 series, the robust filter and vibration tough drive are available instead.
11. The operation mode will be identified automatically at the first controller communication. You can change the operation mode with the application "MR-J4(W)-B mode selection".
12. When MR-J4 is used as a replacement of MR-J3-_S, "Servo forced stop selection" in [Pr. PA04] will be "Disabled (_ 1 _)" in the initial setting. Change the setting as necessary.
13. This is for MR-J4-_B servo amplifier. MR-J4-_B-RJ servo amplifier is compatible with two-wire type, four-wire type, and A/B/Zphase differential output method.
14. It is available with only MR-J4-_B-RJ servo amplifiers. It is not available with MR-J4-_B servo amplifiers.
15. This is available when the J3 extension function is enabled. Refer to section 17.1.9 for details.
16. For servo system controllers which are available with this, contact your local sales office.

Part 8: Common Reference Material

6.1.4 Distinguishing J3 compatibility mode

Following shows the status display of the servo amplifier axis of MR-J4-_B_ and MR-J4W2-_B_. In the states of "Waiting for servo system controller power to switch on (SSCNET III/H communication)" and "Servo system controller power off", the decimal point on the first digit LED turns off in J4 mode, and blinks in J3 compatibility mode. This function can be used with servo amplifiers with software version A5 or later.

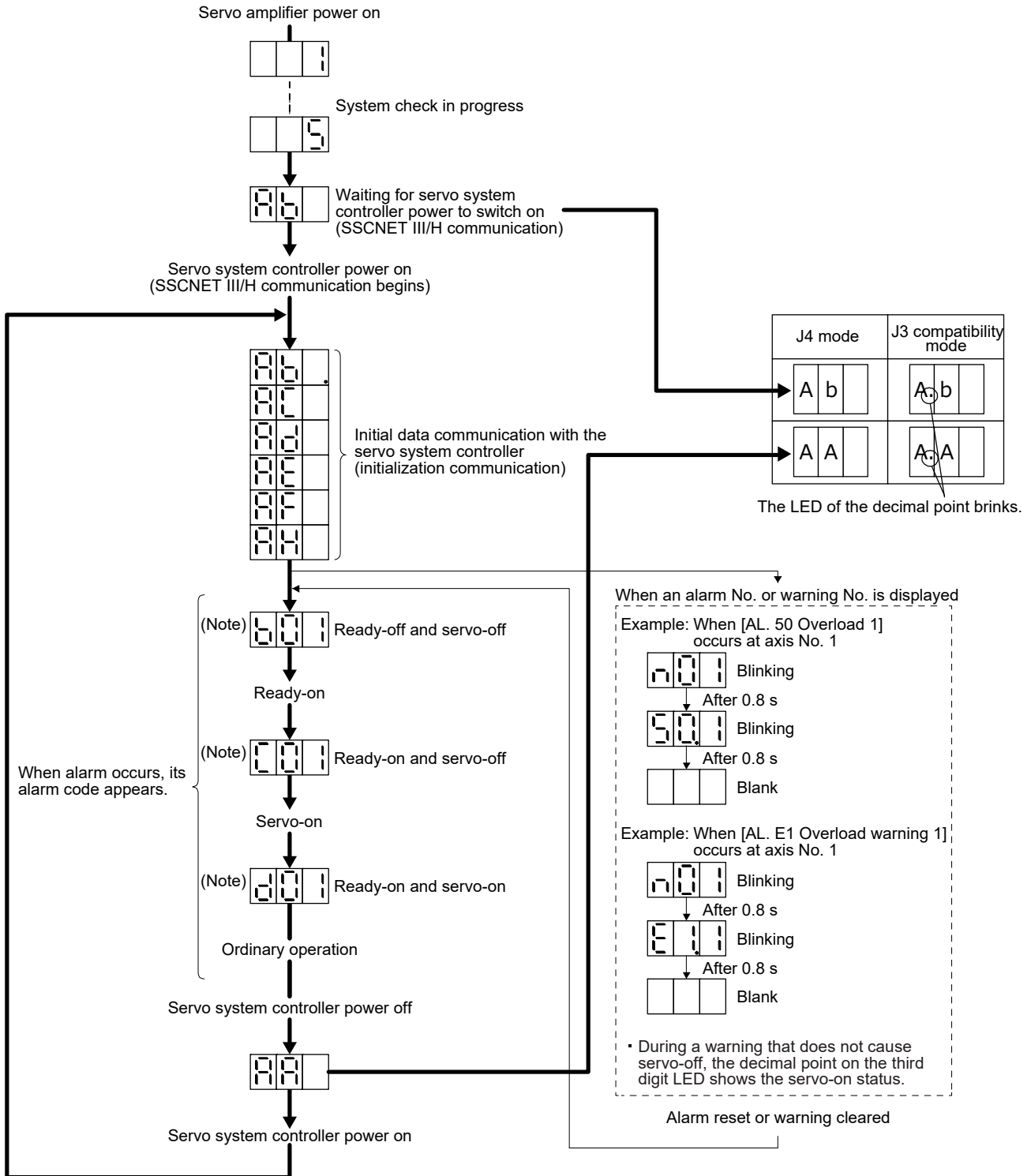

Note.

01	02	...	64
----	----	-----	----

 The segment of the last 2 digits shows the axis number.

Axis No. 1 Axis No. 2 Axis No. 64

Part 8: Common Reference Material

6.1.5 How to switch J4 mode/J3 compatibility mode

There are two ways to switch the J4 mode/J3 compatibility mode with the MR-J4-_B_(-RJ) servo amplifier and MR-J4W2-_B_ servo amplifier.

(1) Mode selection by the automatic identification of the servo amplifier

J4 mode/J3 compatibility mode is identified automatically depending on the connected controller.

When the controller makes a connection request with SSCNET III/H communication, the mode will be "J4 mode". For SSCNET communication, it will be "J3 compatibility mode".

For the J3 compatibility mode, standard control will be identified automatically with a motor (encoder) connected to the servo amplifier. For the J4 mode, the operation mode will be the setting of [Pr. PA01].

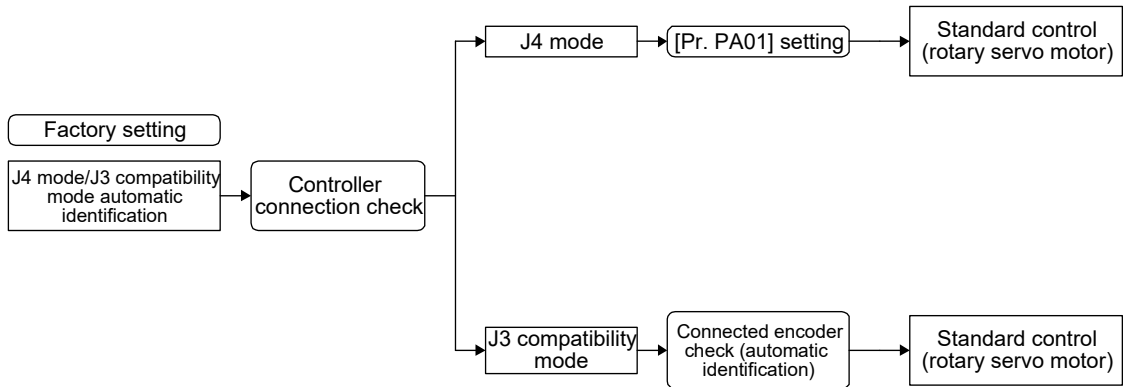

(2) Mode selection using the application software "MR Mode Change"

You can set the factory setting, J4 mode/J3 compatibility mode, and operation mode with the dedicated application.

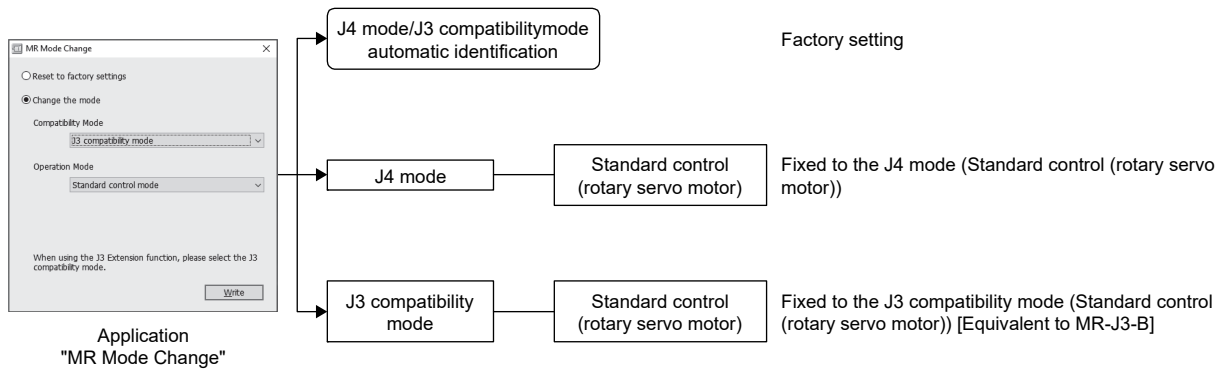

Part 8: Common Reference Material

6.1.6 How to use the J3 compatibility mode

(1) Setting of the controller

To use in the J3 compatibility mode, select MR-J3 series in the system setting window.

Operation mode in J3 compatibility mode	System setting
MR-J3-B standard control mode (rotary servo motor)	Select MR-J3-_B.

(2) Setting of setup software (SETUP221E)

To use in the J3 compatibility mode, make the system setting as follows.

Operation mode in J3 compatibility mode	System setting
MR-J3-B standard control mode (rotary servo motor)	Select MR-J3-_B.

Cautions for using setup software (SETUP221E)

- The gain search cannot be used. You can use the advanced gain search.

(3) Setting of MR Configurator2

To use in the J3 compatibility mode, make the system setting as follows.

Operation mode in J3 compatibility mode	System setting
MR-J3-B standard control mode (rotary servo motor)	Select MR-J3-_B.

Cautions for using MR Configurator2

- Use MR Configurator2 with software version 1.12N or later. Older version than 1.12N cannot be used.
- Information about existing models (MR-J3) cannot be updated with the parameter setting range update function. Register a new model to use.
- The alarm will be displayed by 3 digits.
- The robust disturbance compensation cannot be used.

Part 8: Common Reference Material

6.1.7 Cautions for switching J4 mode/J3 compatibility mode

The J3 compatibility mode of the operation mode is automatically identified by factory setting depending on a connected encoder. If a proper encoder is not connected at the first connection, the system will not start normally due to a mismatch with a set mode with the controller. (For the J4 mode, you can set the operation mode with [Pr. PA01].) When the operation mode mismatches, the servo amplifier will display [AL. 3E.1 Operation mode error]. Set the mode back to the factory setting or set correctly (J4 mode/J3 compatibility mode and operation mode) using the application "MR Mode Change".

6.1.8 Cautions for the J3 compatibility mode

The J3 compatibility mode is partly changed and has restrictions compared with MR-J3 series.

- (1) The alarm display was changed from 2 digits (_ _) to 3 digits (_ _ . _). The alarm detail number (. _) is displayed in addition to the alarm No (_ _). The alarm No. (_ _) is not changed.
- (2) When the power of the servo amplifier is cut or fiber-optic cable is disconnected, the same type communication can be cut regardless of connection order. When you power on/off the servo amplifier during operation, use the connect/disconnect function of the controller. Refer to the following manuals for detail.
 - MELSEC iQ-R Motion Controller Programming Manual (Common) (R16MTCPU/R32MTCPU) (IB-0300237) "5.3.1 Connect/disconnect function of SSCNET communication"
 - Motion controller Q series Programming Manual (COMMON) (Q173D(S)CPU/Q172D(S)CPU) (IB-0300134) "4.11.1 Connect/disconnect function of SSCNET communication"
 - MELSEC iQ-R Simple Motion Module User's Manual (Application) (RD77MS2/RD77MS4/RD77MS8/RD77MS16) (IB-0300247) "8.12 Connect/Disconnect Function of SSCNET Communication"
 - MELSEC-Q QD77MS Simple Motion Module User's Manual (IB-0300185) "14.12 Connect/disconnect function of SSCNET communication"
 - MELSEC-L LD77MH Simple Motion Module User's Manual (IB-0300172) "14.13 Connect/disconnect function of SSCNET communication"
 - MELSEC-L LD77MS Simple Motion Module User's Manual (Positioning Control) (IB-0300211) "14.13 Connect/disconnect function of SSCNET communication"
- (3) The J3 compatibility mode has a functional compatibility. However, the operation timing may differ. Check the operation timing on customer side to use.
- (4) The J3 compatibility mode is not compatible with high-response control set by [Pr. PA01 Operation mode]. Standard control is fixed.
- (5) In J3 compatibility mode, the 350 % maximum torque setting is disabled by default for the HF-KP servo motor. To enable the 350 % maximum torque setting for the HF-KP servo motor, set [Pr. PA01] to " _ 3 _ _ " (Enabled).

Part 8: Common Reference Material

- (6) The J3 compatibility mode of MR-J4W2-_B does not support [Pr. PC15 Station number selection]. Set to "0". To set the axis that communicates with MR Configurator2, open the "New Project" window from the "Project" menu of MR Configurator2, check "Multi-ax, unification", and select "A axis" or "B axis". The communication axis settings are supported by MR Configurator2 with version 1.12N or later.
- (7) The parameter specifications for assigning output devices to the CN3-11 pin and CN3-24 pin in the J3 compatibility mode of MR-J4W2-_B are different from those of MR-J3W-_B.
- MR-J3W-_B: [Pr. PD09]
 - MR-J4W2-_B J3 compatibility mode: [Pr. PD08], [Pr. PD09]
- The parameter specifications of the J3 compatibility mode of MR-J4W2-_B are the same as those of the J4 mode of MR-J4W2-_B.
- Refer to 5.2.4 of "MR-J4W2-_B/MR-J4W3-_B/MR-J4W2-0303B6 Servo Amplifier Instruction Manual" for settings.
- (8) In MR-J4W2-_B, the parameter number of the J3 compatibility mode has changed from "Target alarm selection of the other axis error warning (EB)" of [Pr. Po01] in MR-J3W-_B to "Target alarm selection of the other axis error warning" of [Pr. PF02].
- The parameter specifications of the J3 compatibility mode of MR-J4W2-_B are the same as those of the J4 mode of MR-J4W2-_B.
- Refer to 5.2.6 of "MR-J4W2-_B/MR-J4W3-_B/MR-J4W2-0303B6 Servo Amplifier Instruction Manual" for settings.
- (9) The J3 compatibility mode of MR-J4W2-_B does not support [Pr. Po02 Axis selection for graphing analog data (MR Configurator)] and [Pr. Po03 Axis selection for graphing digital data (MR Configurator)]. Set to "0000h".

Part 8: Common Reference Material

6.1.9 Change of specifications of "J3 compatibility mode" switching process

(1) Detailed explanation of "J3 compatibility mode" switching

(a) Operation when using a servo amplifier before change of specifications

For the controllers in which "Not required" is described to controller reset in table 8.3, the mode will be switched to "J3 compatibility mode" for all axes at the first connection. However, it takes about 10 s per axis for completing the connection.

For the controllers in which "Reset required" is described in table 8.3, the operation at the first connection is shown in table 8.4. The LED displays will be "Ab." for all axes at the first connection to the controller as shown in table 8.4. After that, resetting controller will change the 1-axis to "b01".

The 2-axis and later will not change from "Ab.". After that, one axis will be connected per two times of controller reset.

Table 8.3 Controller reset required/not required list (before change of specifications)

Controller	Model	Controller reset required/not required	
		Single-axis connection	Multi-axis connection
Motion controller	R_MTCPU	Not required	Not required
	Q17_DSCPU	Not required	Not required
	Q17_DCPU	Not required	Not required
	Q17_HCPU	Not required	Not required
	Q170MCP	Not required	Not required
Simple motion module Positioning module	RD77MS_	Not required	Not required
	QD77MS_	Not required	Not required
	LD77MS_	Not required	Not required
	QD75MH_	Not required	Not required
	QD74MH_	Reset required	Reset required
	LD77MH_	Not required	Not required
	FX3U-20SSC-H	Not required	Reset required

Table 8.4 Controller connection operation before change of specifications

	Before change of specifications (software version A4 or earlier)
First connection of controller	<p>Controller "Ab." is displayed and stops</p> <p>Axis No. 1: A b . Axis No. 2: A b . Axis No. 3: A b .</p>
After controller reset	<p>Controller "b01" is displayed on axis No. 1, "Ab." is displayed on axis No. 2 and later.</p> <p>Axis No. 1: b 0 1 Axis No. 2: A b . Axis No. 3: A b . One axis is connecter per reset.</p>

Part 8: Common Reference Material

(b) Operation when using a servo amplifier after change of specifications

For the controllers in which "Not required" is described to controller reset in table 8.5, the mode will be switched to "J3 compatibility mode" for all axes at the first connection. It takes about 10 s for completing the connection not depending on the number of axes.

For the controllers in which "Reset required" is described in table 8.5, the operation at the first connection is shown in table 8.6. The servo amplifier's mode will be "J3 compatibility mode" and the LED displays will be "rST" for all axes at the first connection to the controller as shown in table 8.6. At the status, resetting controller once will change the display to "b##" (## means axis No.) for all axes and all axes will be ready to connect.

(One controller reset enables to all-axis connection.)

Table 8.5 Controller reset required/not required list (after change of specifications)

Controller	Model	Controller reset required/not required	
		Single-axis connection	Multi-axis connection
Motion controller	R_MTCPU	Not required	Not required
	Q17_DSCPU	Not required	Not required
	Q17_DCPU	Not required	Not required
	Q17_HCPU	Not required	Not required
	Q170MCPUCPU	Not required	Not required
Simple motion module Positioning module	RD77MS_	Not required	Not required
	QD77MS_	Not required	Not required
	LD77MS_	Not required	Not required
	QD75MH_	Not required	Not required
	QD74MH_	Reset required	Reset required
	LD77MH_	Not required	Not required
	FX3U-20SSC-H	Reset required	Reset required

Table 8.6 Controller connection operation after change of specifications

	After change of specifications (software version A5 or above)
First connection of controller	<p>Controller "rST" is displayed only for the first connection</p>
After controller reset	<p>Controller All axes are connected by one reset</p>

(c) Using servo amplifiers before and after change of specifications simultaneously

When using servo amplifiers before change of specifications and after change of specifications simultaneously, controller reset is necessary for number of connecting axes of servo amplifiers.

Part 8: Common Reference Material

- (2) Changing the mode to "J3 compatibility mode" by using the application "MR Mode Change".
 You can switch the servo amplifier's mode to "J3 compatibility mode" beforehand with the built-in application software "MR Mode Change" of MR Configurator2. Use it for a solution when it is difficult to reset many times with your "Reset required" controller such as "QD74MH_".
 The application "MR Mode Change" has no expiration date.

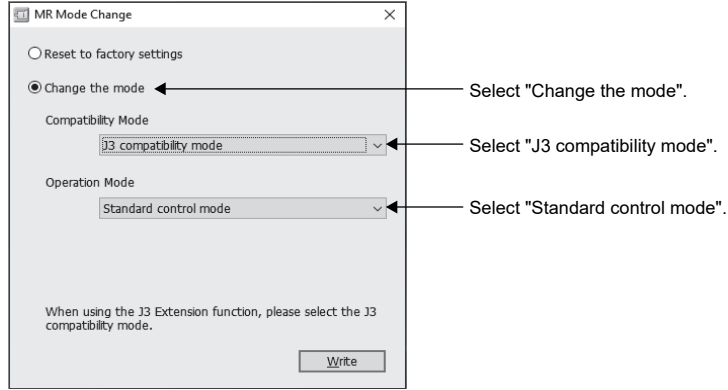

6.1.10 J3 extension function

POINT
<ul style="list-style-type: none"> ● The J3 extension function is used with servo amplifiers with software version B0 or later. ● To enable the J3 extension function, MR Configurator2 with software version 1.25B or later is necessary. ● The J3 extension function of the amplifier differs from MR-J3-B in motion. ● For details of the J3 extension function, refer to each servo amplifier instruction manual.

The J3 extension function is for using functions of J4 mode with J3 compatibility mode.
 By enabling the J3 extension function, control response will be equal to MR-J4 series using a controller compatible with SSCNET III.

J4 mode	J3 compatibility mode	
	J3 extension function enabled: [Pr. PX01] = "___1"	J3 extension function disabled: [Pr. PX01] = "___0"
<ul style="list-style-type: none"> • SSCNET III/H communication • MR-J4-B function 	<ul style="list-style-type: none"> • SSCNET III communication • The same parameter ordering as MR-J3-B • MR-J4-B control function • Parameter added 	<ul style="list-style-type: none"> • SSCNET III communication • The same parameter ordering as MR-J3-B

Part 8: Common Reference Material

The following shows functions used with the J3 extension function. Refer to each servo amplifier instruction manual for details.

Function	Description
Gain switching function (Vibration suppression control 2 and model loop gain)	You can switch gains during rotation/stop, and can use input devices to switch gains during operation.
Advanced vibration suppression control II	This function suppresses vibration at the arm end or residual vibration.
Machine resonance suppression filter 3 Machine resonance suppression filter 4 Machine resonance suppression filter 5	This is a filter function (notch filter) which decreases the gain of the specific frequency to suppress the resonance of the mechanical system.
Shaft resonance suppression filter	When a load is mounted to the servo motor shaft, resonance by shaft torsion during driving may generate a mechanical vibration at high frequency. The shaft resonance suppression filter suppresses the vibration.
Robust filter	This function provides better disturbance response in case low response level that load to motor inertia ratio is high for such as roll send axes.
One-touch tuning	Gain adjustment is performed just by one click on a certain button on MR Configurator2. MR Configurator2 is necessary for this function.
Tough drive function	This function makes the equipment continue operating even under the condition that an alarm occurs. The tough drive function includes two types: the vibration tough drive and the instantaneous power failure tough drive.
SEMI-F47 function (Note 1)	Enables to avoid triggering [AL. 10 Undervoltage] using the electrical energy charged in the capacitor in case that an instantaneous power failure occurs during operation. Use a 3-phase for the input power supply of the servo amplifier. Using a 1-phase 200 V AC for the input power supply will not comply with SEMI-F47 standard.
Drive recorder function	This function continuously monitors the servo status and records the status transition before and after an alarm for a fixed period of time. You can check the recorded data on the drive recorder window on MR Configurator2 by clicking the "Graph" button. However, the drive recorder will not operate on the following conditions. 1. You are using the graph function of MR Configurator2. 2. You are using the machine analyzer function. 3. [Pr. PX30] is set to "-1". 4. The controller is not connected (except the test operation mode). 5. An alarm related to the controller is occurring.
Power monitoring function	This function calculates the power running energy and the regenerative power from the data in the servo amplifier such as speed and current. Power consumption and others are displayed on MR Configurator2 in the system of SSCNET III/H. Since the servo amplifier sends data to a servo system controller, you can analyze the data and display the data on a display.
Machine diagnosis function	From the data in the servo amplifier, this function estimates the friction and vibrational component of the drive system in the equipment and recognizes an error in the machine parts, including a ball screw and bearing. MR Configurator2 is necessary for this function.
Lost motion compensation function (Note 2)	This function improves the response delay occurred when the machine moving direction is reversed. This is used with servo amplifiers with software version B4 or later. Check the software version of the servo amplifier using MR Configurator2.

- Note 1. For servo system controllers which are available with this, contact your local sales office.
2. It is not available with MR-J4W2-_B servo amplifiers.

6.2 Master-slave operation function



WARNING

- Configure the circuit so that all the master and slave axes for the same machine are stopped by the controller forced stop at the moment of a stop of a master or slave axis due to such as a servo alarm. When they are not stopped simultaneously by the controller forced stop, the servo motor may operate unexpectedly and the machine can be damaged.
- All the master and slave axes for the same machine should turn on/off EM1 (Forced stop 1) simultaneously. When EM1 (Forced stop 1) is not turned on/off simultaneously, the servo motor may operate unexpectedly and the machine can be damaged.

POINT

- The master-slave operation function works only when the forced stop deceleration function is disabled. When the forced stop deceleration function is enabled, [AL. 37 Parameter error] will occur.
- The master-slave operation function cannot be used with the continuous operation to torque control.
- Use the master-slave operation function with the following controllers. Refer to the manuals for each servo system controller for compatible software versions, and other details.
RD77MS/QD77MS_/LD77MS_
R_MTCPU/Q17_DSCPU
Q170MSCPU
- When the function is used in vertical axis system, set the same value to the parameters regarding the dynamic brake and electromagnetic brake to prevent a drop of axes.
- The servo-on command of the master axis and slave axis should be turned on/off simultaneously. If the servo-on command is turned on only for a slave axis, torque will not be generated. Therefore, an extreme load will be applied to the electromagnetic brake of the master axis for using in vertical axis system.
- The master-slave operation function is available for servo amplifier with software version A8 or later. All servo amplifiers used in the same system connected to a controller should be software version A8 or later.
- It is not available with MR-J4W2-_B servo amplifiers.

Part 8: Common Reference Material

(1) Summary

The master-slave operation function transmits a master axis torque to slave axes using driver communication and the torque as a command drives slave axes by torque control.

Transmission of torque data from the master axis to slave axes is via SSCNET III/H. Additional wiring is not required.

(2) System configuration

POINT				
	<p>● The control modes compatible with the master-slave operation function are as follows.</p>			
	<p>Master-slave operation function compatibility table</p>			
	Control mode	Forced stop deceleration function	Master axis (Note)	Slave axis (Note)
	Standard control mode	Enabled	/	/
		Disabled	○	○
			○: Available	
	<p>Note. When a setting for the master-slave operation is set to an axis which is not compatible with the master-slave operation function, [AL. 37 Parameter error] will occur.</p>			
	<p>● The master axis and slave axis are recommended to use for a linked condition on a mechanical constitution. When they are not linked, they can reach a speed limit level. Doing so may cause [AL. 31 Overspeed].</p>			
	<p>● The slave axes use the control command from the master axis. Therefore, the controller mainly controls parameter settings, servo-on command, acquisition of monitor information from a servo amplifier, etc. The commands regarding absolute positioning such as setting absolute position detection and requiring home position setting from the controller to slave axes must not be made.</p>			
	<p>● Configure the circuit so that all the master and slave axes are stopped at the moment of a stop of a master or slave axis due to such as a servo alarm.</p>			
	<p>● When the STO signal of a servo amplifier is used, the master axis and slave axis should be turned off simultaneously.</p>			

Part 8: Common Reference Material

Eight master axes can be set at most per one system of SSCNET III/H. The maximum number of slave axes to each master axis is not limited. However, the total number of the master and slave axes should be the maximum number of the servo amplifiers at most. In addition, when an SSCNET III/H communication shut-off occurs due to malfunction of a servo amplifier, the malfunctioning axis and later axis cannot be communicated. Therefore, the first amplifier from the controller via SSCNET III/H cable should be master axis.

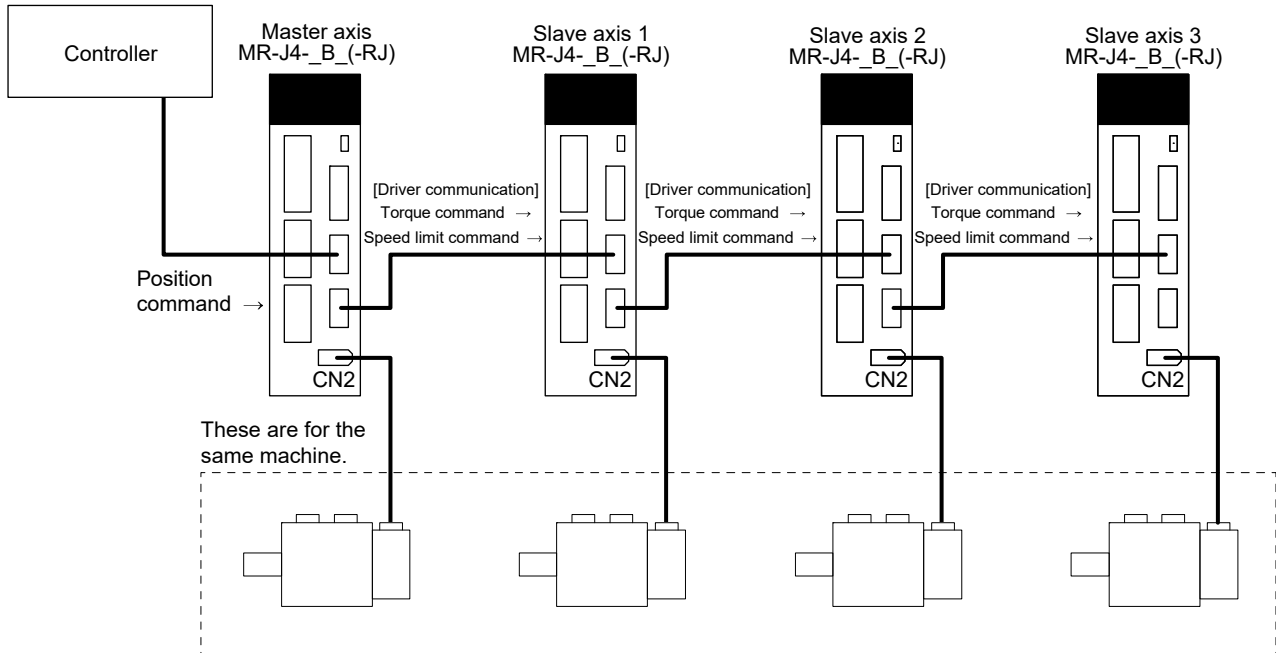

(3) Parameter setting for the master-slave operation function

To use the master-slave operation function, the following parameter settings are necessary. For details of the parameters, refer to "Part:3, section 3.6.3".

No.	Name	Initial value	Setting value		Setting
			Master axis	Slave axis	
PA04	Forced stop deceleration function selection	2000	0 ___	0 ___	Used to disable the forced stop deceleration function.
PA14	Rotation direction selection/travel direction selection	0	Refer to "Part:3, section 3.6.3".		Used to set a torque generation direction.
PD15 (Note)	Driver communication setting	0000	0001	0010	Master and slave setting
PD16 (Note)	Driver communication setting - Master - Transmit data selection 1	0000	0038	0000	Communication data from master to slave • Torque command • Speed limit value
PD17 (Note)	Driver communication setting - Master - Transmit data selection 2	0000	003A	0000	
PD20 (Note)	Master axis No. selection 1 for slave	0	0	Master axis No.	Master axis No. of transmitting data
PD30	Master-slave operation - Torque command coefficient on slave	0	0	Refer to "Part:3, section 3.6.3".	Ratio of torque command of slave axis, ratio of speed limit value, and setting of speed limit minimum value
PD31	Master-slave operation - Speed limit coefficient on slave	0	0		
PD32	Master-slave operation - Speed limit adjusted value on slave	0	0		

Note. Always set this with servo parameters of the controller. Incorrect setting will prevent a normal SSCNET III/H communication.

Part 8: Common Reference Material

(4) Rotation direction setting

Rotation directions can be different among a controller command, master axis, and slave axes. To align the directions, set [Pr. PA14] referring to (4) of this section. Not doing so can cause such as an overload due to a reverse direction torque against machine system rotation direction.

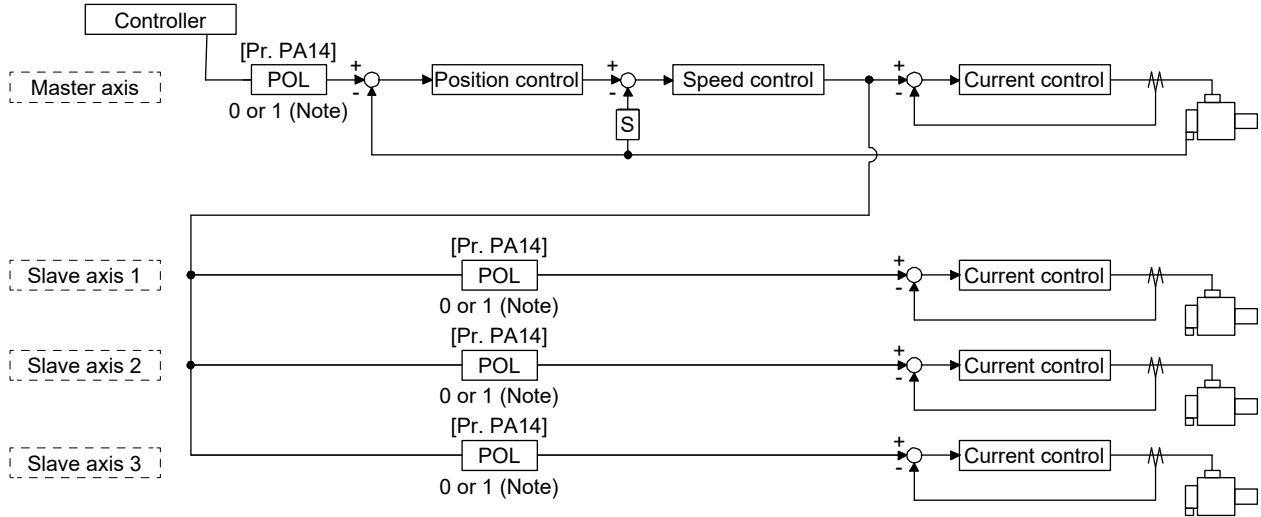

Note. Setting "1" will reverse the polarity.

Rotation direction setting of master and slave axes with torque command method for an example of one master axis and three slave axes

Table 8.7 Rotation direction setting parameter

No.	Symbol	Name and function
PA14	*POL	Rotation direction selection 1. For master axis Select a servo motor rotation direction of master axis to SSCNET controller command. 0: Servo motor CCW rotation in positioning address increase direction 1: Servo motor CW rotation in positioning address increase direction 2. For slave axis Select servo motor rotation direction to a command from master axis. 0: Torque command polarity from master axis 1: Reverse of torque command polarity from master axis

The following shows a setting example of rotation direction for a platform truck with one master axis and three slave axes.

To set a rotation direction of the servo motor according to the moving direction, set the torque command polarity to the slave axis 1 the same as that to the master axis, and set the opposite polarity to the slave axis 2 and slave axis 3 from the master axis.

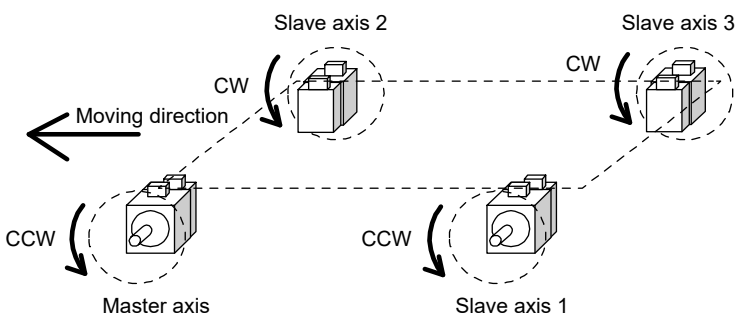

[Pr. PA14] setting

Axis	[Pr. PA14]
Master axis	0
Slave axis 1	0
Slave axis 2	1
Slave axis 3	1

Part 8: Common Reference Material

6.3 Scale measurement function

The scale measurement function transmits position information of a scale measurement encoder to the controller by connecting the scale measurement encoder in semi closed loop control.

POINT
<ul style="list-style-type: none"> ● The scale measurement function is available for the servo amplifiers of software version A8 or later. ● When the scale measurement function is used for MR-J4-_B_ or MR-J4W2-_B_ servo amplifiers, the following restrictions apply. However, these restrictions will not be applied for MR-J4-_B_-RJ servo amplifiers. <ul style="list-style-type: none"> ▪ A/B/Z-phase differential output type encoder cannot be used. ▪ The scale measurement encoder and servo motor encoder are compatible with only the two-wire type. The four-wire type scale measurement encoder and servo motor encoder cannot be used. ● When you use the HG-KR and HG-MR series for driving and scale measurement encoder, the optional four-wire type encoder cables (MR-EKCBL30M-L, MR-EKCBL30M-H, MR-EKCBL40M-H, and MR-EKCBL50M-H) cannot be used. When an encoder cable of 30 m to 50 m is needed, fabricate a two-wire type encoder cable according to "MR-J4-_B_-RJ)_ Servo Amplifier Instruction Manual" or "MR-J4W2-_B_/MR-J4W3-_B_/MR-J4W2-0303B6 Servo Amplifier Instruction Manual". ● The scale measurement function compatible servo amplifier can be used with any of the following controllers. <ul style="list-style-type: none"> ▪ Motion controller R_MTCPUI/Q17_DSCPU ▪ Simple motion module RD77MS/QD77MS_/LD77MS_ (The MR-J4W2-_B_ servo amplifiers are not available with simple Motion module.) <p>For settings and restrictions of controllers compatible with the scale measurement function, refer to user's manuals for each controller.</p> ● The MR-J4W2-0303B6 servo amplifier is not compatible with the scale measurement function.

6.3.1 Functions and configuration

(1) Function block diagram

The following shows a block diagram of the scale measurement function. The control will be performed per servo motor encoder unit for the scale measurement function.

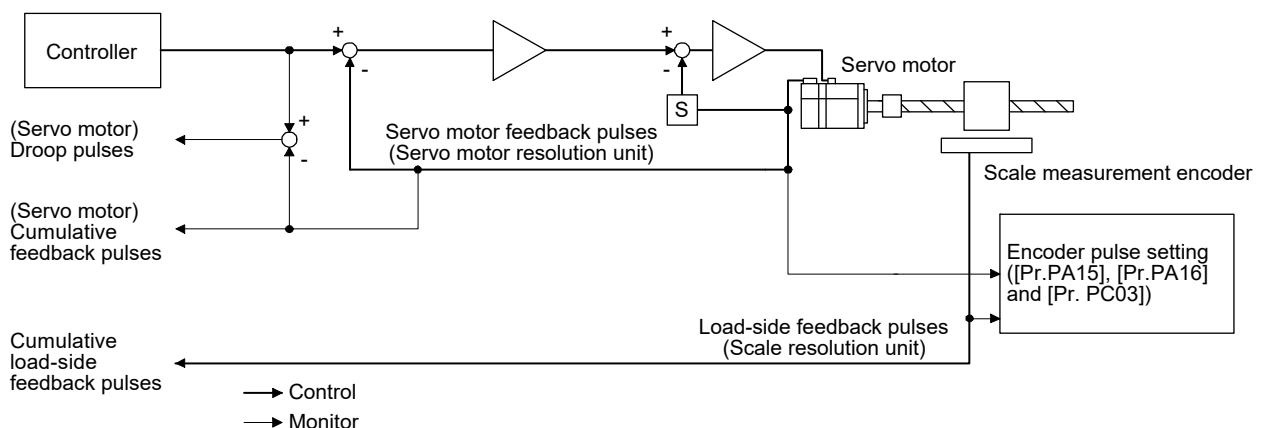

Part 8: Common Reference Material

- (2) System configuration
 - (a) For a rotary encoder
 - 1) MR-J4-_B_ servo amplifier

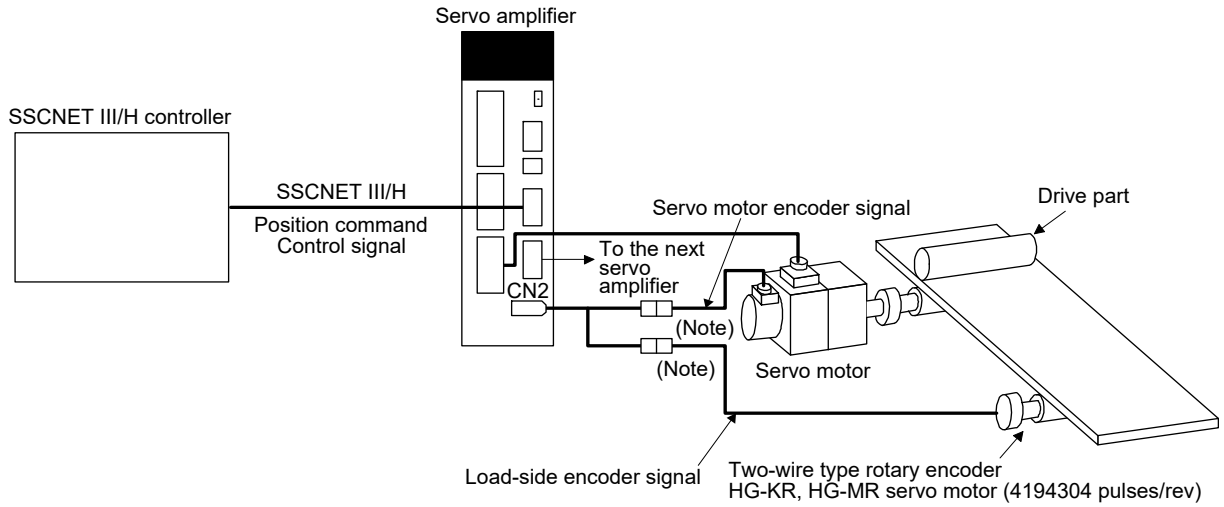

Note Use a two-wire type encoder cable. A four-wire type linear encoder cable cannot be used.

- 2) MR-J4W2-_B_ servo amplifier

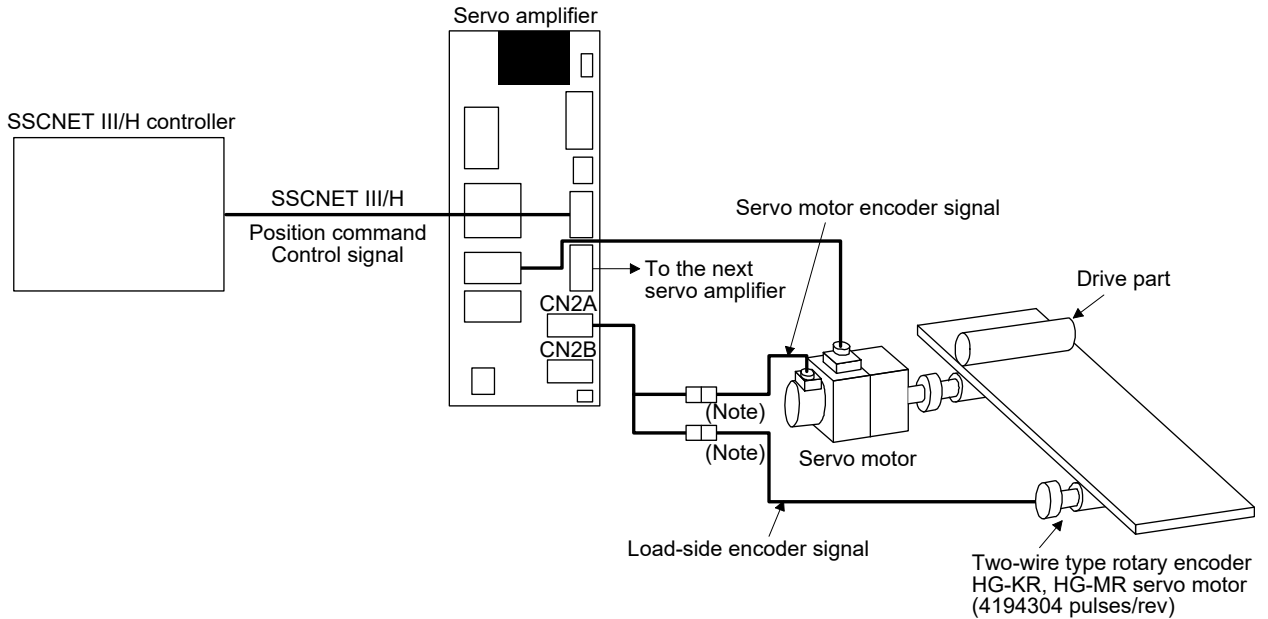

Note. Use a two-wire type encoder cable. A four-wire type linear encoder cable cannot be used.

Part 8: Common Reference Material

6.3.2 Scale measurement encoder

POINT
<ul style="list-style-type: none"> ● Always use the scale measurement encoder cable introduced in this section. Using other products may cause a malfunction. ● For details of the scale measurement encoder specifications, performance and assurance, contact each encoder manufacturer.

When a rotary encoder is used, an absolute position detection system can be configured by installing the encoder battery to the servo amplifier. In this case, the battery life will be shorter because the power consumption is increased as the power is supplied to the two encoders of motor side and load side.

(1) Rotary encoder

When a rotary encoder is used as a scale measurement encoder, use the following servo motor or synchronous encoder as the encoder.

Servo motor and synchronous encoder that can be used as encoder

	HG-KR	HG-MR
MR-J4-_B_	○	○

○: Available

Servo motors used as encoders

	HG-KR	HG-MR
MR-J4W2-_B	○	○

Use a two-wire type encoder cable. Do not use MR-EKCBL30M-L, MR-EKCBL30M-H, MR-EKCBL40M-H, or MR-EKCBL50M-H as they are four-wire type.

When an encoder cable of 30 m to 50 m is needed, fabricate a two-wire type encoder cable according to "MR-J4-_B_(-RJ) Servo Amplifier Instruction Manual" or "MR-J4W2-_B/MR-J4W3-_B/MR-J4W2-0303B6 Servo Amplifier Instruction Manual".

To use the scale measurement function in the absolute position detection system ([Pr. PA22] = 1__), the encoder battery must be installed to the servo amplifier for backing up the absolute position data of the load side. In this case, the battery life will be shorter because the power consumption is increased as the power is supplied to the two encoders of motor side and load side.

Part 8: Common Reference Material

(2) Configuration diagram of encoder cable

Configuration diagram for servo amplifier and scale measurement encoder is shown below. Cables vary depending on the scale measurement encoder.

(a) Rotary encoder

Refer to "HG-MR/HG-KR/HG-SR/HG-JR/HG-RR/HG-UR/HG-AK Servo Motor Instruction Manual (Vol. 3)" for encoder cables for rotary encoders.

1) MR-J4-_B_ servo amplifier

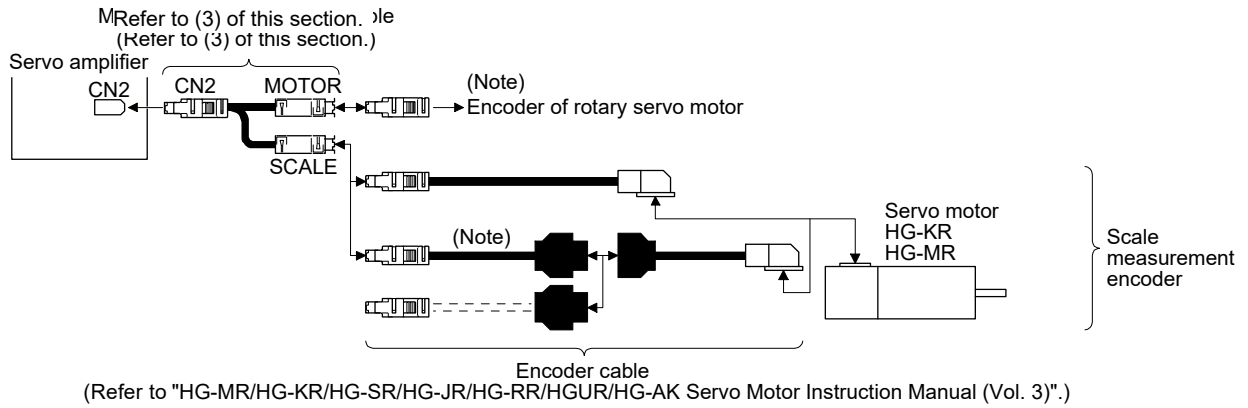

Note Use a two-wire type encoder cable. A four-wire type linear encoder cable cannot be used.

2) MR-J4W2-_B_ servo amplifier

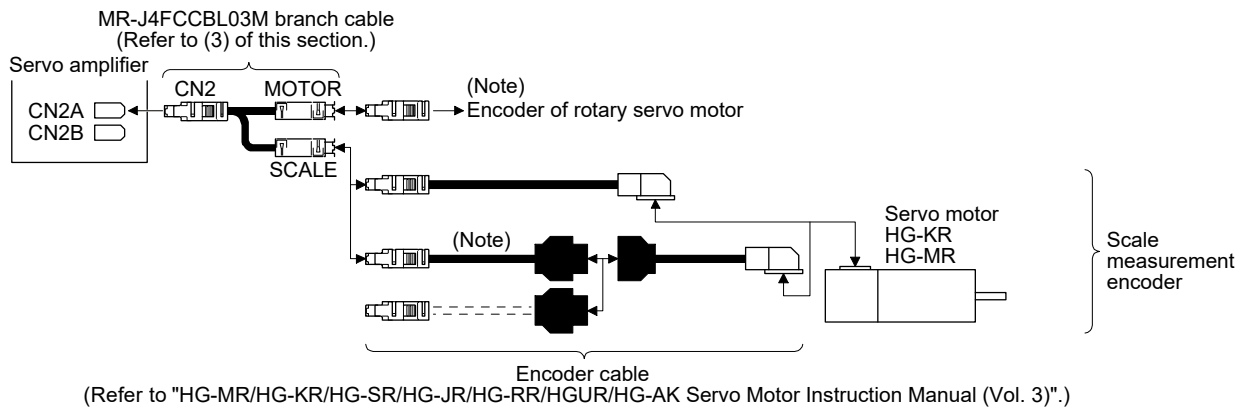

Note. Use a two-wire type encoder cable. A four-wire type linear encoder cable cannot be used.

Part 8: Common Reference Material

(3) MR-J4FCCBL03M branch cable

Use MR-J4FCCBL03M branch cable to connect the scale measurement encoder to CN2 connector. When fabricating the branch cable using MR-J3THMCN2 connector set, refer to "Linear Encoder Instruction Manual".

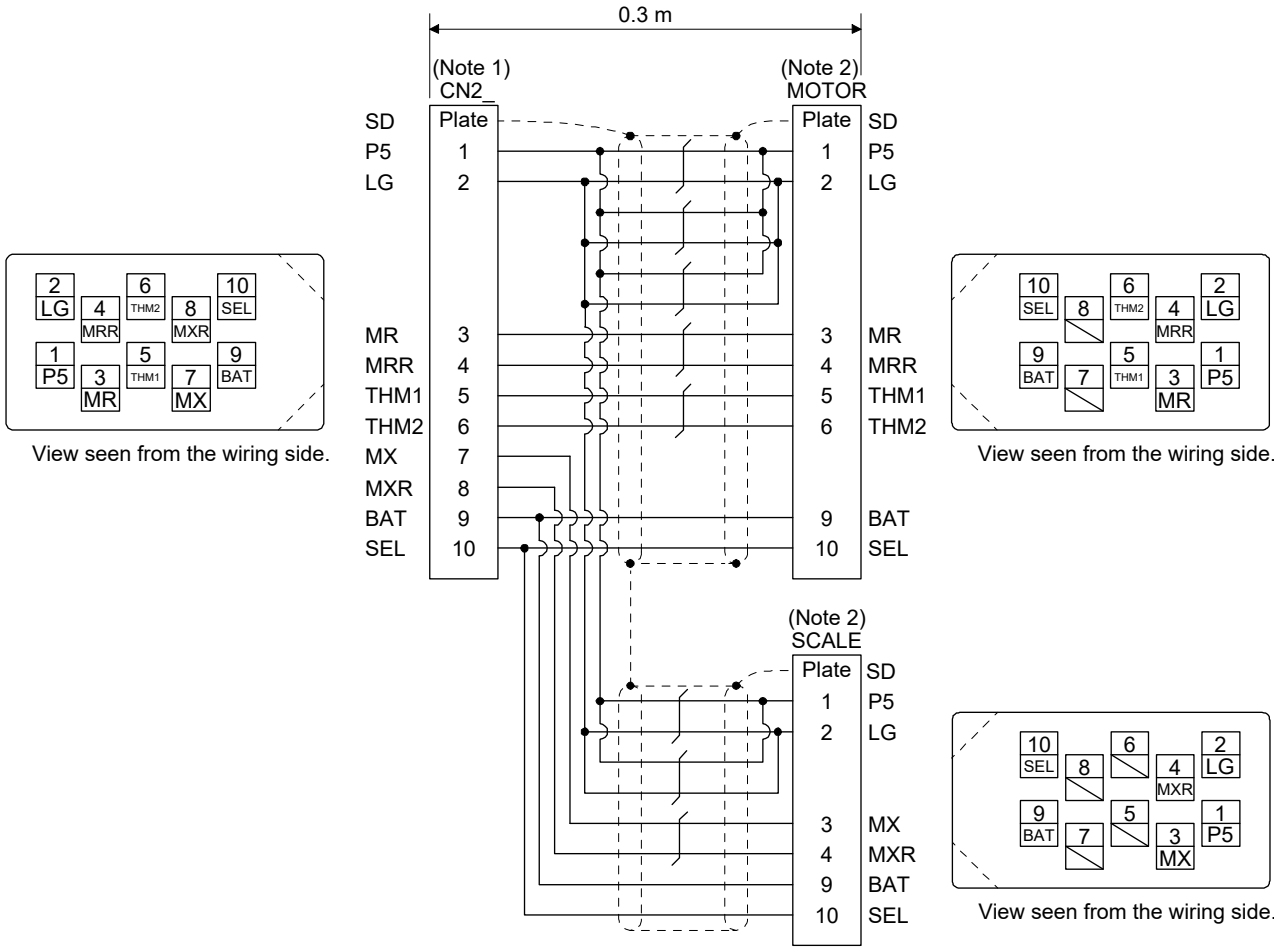

- Note 1. Receptacle: 36210-0100PL, shell kit: 36310-3200-008 (3M)
 Note 2. Plug: 36110-3000FD, shell kit: 36310-F200-008 (3M)

Part 8: Common Reference Material

6.3.3 How to use scale measurement function

(1) Selection of scale measurement function

The scale measurement function is set with the combination of basic setting parameters [Pr. PA01] and [Pr. PA22].

(a) Operation mode selection

The scale measurement function can be used during semi closed loop system (standard control mode). Set [Pr. PA01] to "_ _ 0 _".

[Pr. PA01]
1 0 0

Operation mode selection

Setting value	Operation mode	Control unit
0	Semi closed loop system (Standard control mode)	Servo motor-side resolution unit

(b) Scale measurement function selection

Select the scale measurement function. Select "1 _ _ _" (Used in absolute position detection system) or "2 _ _ _" (Used in incremental system) according to the encoder you use.

[Pr. PA22]
 0 0 0

Scale measurement function selection

0: Disabled

1: Used in absolute position detection system

2: Used in incremental system

(2) Selection of scale measurement encoder communication method and polarity.

For MR-J4-_B_-RJ servo amplifiers, set the following "Load-side encoder communication method selection" of [Pr. PC26] as necessary.

The communication method differs depending on the scale measurement encoder type. Select "Four-wire type" because there is only four-wire type for synchronous encoder.

Select the cable to be connected to CN2L connector in [Pr. PC26].

[Pr. PC26]
 0 0 0

Load-side encoder cable communication method selection

0: Two-wire type

1: Four-wire type

When using a load-side encoder of A/B/Z-phase differential output method, set "0".

Incorrect setting will trigger [AL. 70 Load-side encoder initial communication error 1] and [AL. 71 Load-side encoder normal communication error 1].

Setting "1" while using an MR-J4-_B_- servo amplifier will trigger [AL. 37 Parameter error].

Select a polarity of the scale measurement encoder with the following "Encoder pulse count polarity selection" and "Selection of A/B/Z-phase input interface encoder Z-phase connection judgement function" of [Pr. PC27] as necessary.

POINT
● "Encoder pulse count polarity selection" in [Pr. PC27] is not related to [Pr. PA14 Rotation direction selection]. Make sure to set the parameter according to the relationships between servo motor and linear encoder/rotary encoder.

Part 8: Common Reference Material

(a) Parameter setting method

1) Select an encoder pulse count polarity.

This parameter is used to set the load-side encoder polarity to be connected to CN2L connector in order to match the CCW direction of servo motor and the increasing direction of load-side encoder feedback. Set this as necessary.

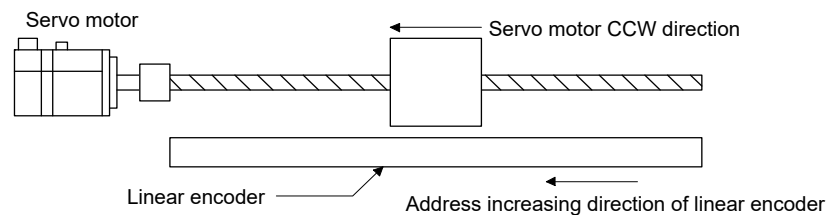
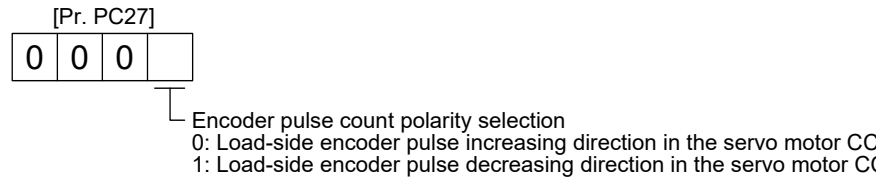

2) A/B/Z-phase input interface encoder Z-phase connection judgement function (It is not available with MR-J4W2-_B servo amplifiers.)

This function can trigger an alarm by detecting non-signal for Z phase.

The Z-phase connection judgement function is enabled by default. To disable the Z-phase connection judgement function, set [Pr. PC27].

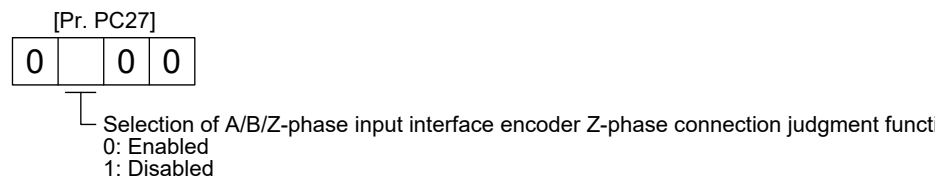

(b) How to confirm the scale measurement encoder feedback direction

You can confirm the directions of the cumulative feedback pulses of servo motor encoder and the load-side cumulative feedback pulses are matched by moving the device (scale measurement encoder) manually in the servo-off status. If mismatched, reverse the polarity.

(3) Confirmation of scale measurement encoder position data

Check the scale measurement encoder mounting and parameter settings for any problems.

Operate the device (scale measurement encoder) to check the data of the scale measurement encoder is renewed correctly. If the data is not renewed correctly, check the wiring and parameter settings.

Change the scale polarity as necessary.

Part 9
Review on Replacement
of Motor

Part 9: Review on Replacement of Motor

Part 9: Review on Replacement of Motor

1. SERVO MOTOR REPLACEMENT

1.1 Servo Motor Replacement Model and Compatibility

POINT																																		
<ul style="list-style-type: none"> ● For details about the compatibility of servo motor dimensions, reducer specifications, moment of inertia, connector specifications, and torque characteristics, refer to "Chapter 2 COMPARISON OF SERVO MOTOR SPECIFICATIONS". ● The symbols in the table mean as follows. (B): With brake (4): 400 V specifications (H): Foot-mounting ● When an "HA-LP motor" shown below is used, "simultaneous replacement with MR-J4-<u>A</u>-(-RJ)/MR-J4-<u>B</u> and an HG motor" is recommended. When an HG motor is adopted, the capacity of the servo amplifier needs to be changed. (Consider replacement, referring to "2.7 Comparison of Servo Motor Torque Characteristics".) 																																		
<table border="1" style="width: 100%; border-collapse: collapse;"> <thead> <tr> <th colspan="2" style="text-align: center;">Existing device models</th> <th colspan="2" style="text-align: center;">Replacement models for simultaneous replacement (example)</th> </tr> <tr> <th style="text-align: center;">Servo motor</th> <th style="text-align: center;">Servo amplifier</th> <th style="text-align: center;">Servo motor</th> <th style="text-align: center;">Servo amplifier</th> </tr> </thead> <tbody> <tr> <td rowspan="2" style="text-align: center;">HA-LP25K14</td> <td rowspan="2" style="text-align: center;">MR-J3-DU30K_4</td> <td style="text-align: center;">HG-JR25K14</td> <td rowspan="2" style="text-align: center;">MR-J4-22K_4(-RJ)</td> </tr> <tr> <td style="text-align: center;">HG-JR25K14R-S_ (Note)</td> </tr> <tr> <td rowspan="2" style="text-align: center;">HA-LP30K2(4)</td> <td rowspan="2" style="text-align: center;">MR-J3-DU30K_(4)</td> <td style="text-align: center;">HG-JR22K1M(4)</td> <td rowspan="2" style="text-align: center;">MR-J4-22K_(4)(-RJ)</td> </tr> <tr> <td style="text-align: center;">HG-JR22K1M(4)R-S_ (Note)</td> </tr> <tr> <td rowspan="2" style="text-align: center;">HA-LP37K2(4)</td> <td rowspan="2" style="text-align: center;">MR-J3-DU37K_(4)</td> <td style="text-align: center;">HG-JR30K1M(4)</td> <td rowspan="2" style="text-align: center;">MR-J4-DU30K_(4)</td> </tr> <tr> <td style="text-align: center;">HG-JR30K1M(4)R-S_ (Note)</td> </tr> <tr> <td rowspan="2" style="text-align: center;">HA-LP45K24</td> <td rowspan="2" style="text-align: center;">MR-J3-DU45K_4</td> <td style="text-align: center;">HG-JR37K1M4</td> <td rowspan="2" style="text-align: center;">MR-J4-DU37K_4</td> </tr> <tr> <td style="text-align: center;">HG-JR37K1M4R-S_ (Note)</td> </tr> <tr> <td rowspan="2" style="text-align: center;">HA-LP55K24</td> <td rowspan="2" style="text-align: center;">MR-J3-DU55K_4</td> <td style="text-align: center;">HG-JR45K1M4</td> <td rowspan="2" style="text-align: center;">MR-J4-DU45K_4</td> </tr> <tr> <td style="text-align: center;">HG-JR45K1M4R-S_ (Note)</td> </tr> </tbody> </table>		Existing device models		Replacement models for simultaneous replacement (example)		Servo motor	Servo amplifier	Servo motor	Servo amplifier	HA-LP25K14	MR-J3-DU30K_4	HG-JR25K14	MR-J4-22K_4(-RJ)	HG-JR25K14R-S_ (Note)	HA-LP30K2(4)	MR-J3-DU30K_(4)	HG-JR22K1M(4)	MR-J4-22K_(4)(-RJ)	HG-JR22K1M(4)R-S_ (Note)	HA-LP37K2(4)	MR-J3-DU37K_(4)	HG-JR30K1M(4)	MR-J4-DU30K_(4)	HG-JR30K1M(4)R-S_ (Note)	HA-LP45K24	MR-J3-DU45K_4	HG-JR37K1M4	MR-J4-DU37K_4	HG-JR37K1M4R-S_ (Note)	HA-LP55K24	MR-J3-DU55K_4	HG-JR45K1M4	MR-J4-DU45K_4	HG-JR45K1M4R-S_ (Note)
Existing device models		Replacement models for simultaneous replacement (example)																																
Servo motor	Servo amplifier	Servo motor	Servo amplifier																															
HA-LP25K14	MR-J3-DU30K_4	HG-JR25K14	MR-J4-22K_4(-RJ)																															
		HG-JR25K14R-S_ (Note)																																
HA-LP30K2(4)	MR-J3-DU30K_(4)	HG-JR22K1M(4)	MR-J4-22K_(4)(-RJ)																															
		HG-JR22K1M(4)R-S_ (Note)																																
HA-LP37K2(4)	MR-J3-DU37K_(4)	HG-JR30K1M(4)	MR-J4-DU30K_(4)																															
		HG-JR30K1M(4)R-S_ (Note)																																
HA-LP45K24	MR-J3-DU45K_4	HG-JR37K1M4	MR-J4-DU37K_4																															
		HG-JR37K1M4R-S_ (Note)																																
HA-LP55K24	MR-J3-DU55K_4	HG-JR45K1M4	MR-J4-DU45K_4																															
		HG-JR45K1M4R-S_ (Note)																																
<p>Note. Only flanges and shaft ends have compatibility in mounting. Please contact your local sales office regarding the motor model and its delivery, since it is developed upon receipt of order.</p>																																		

Part 9: Review on Replacement of Motor

(1) HF-KP series (With gears for general industrial machines with a reducer)

Series	Model	Example of replacement model	Compatibility (O: Compatible)	Note
Small capacity, low inertia HF-KP series Standard/With brake	HF-KP053(B)	HG-KR053(B)	O	
	HF-KP13(B)	HG-KR13(B)		
	HF-KP23(B)	HG-KR23(B)		
	HF-KP43(B)	HG-KR43(B)		
	HF-KP73(B)	HG-KR73(B)		
Small capacity, low inertia HF-KP series With gears for general industrial machines: G1	HF-KP053(B)G1 1/5	HG-KR053(B)G1 1/5	O	<ul style="list-style-type: none"> Because the reduction gears of models marked with ◆ are different from the actual reduction ratio, it is required that an electronic gear be set up. Refer to "2.4 Comparison of actual reduction ratios for geared servo motors" for the details.
	HF-KP053(B)G1 1/12	HG-KR053(B)G1 1/12		
	HF-KP053(B)G1 1/20	HG-KR053(B)G1 1/20		
	HF-KP13(B)G1 1/5	HG-KR13(B)G1 1/5		
	HF-KP13(B)G1 1/12	HG-KR13(B)G1 1/12		
	HF-KP13(B)G1 1/20	HG-KR13(B)G1 1/20		
	HF-KP23(B)G1 1/5	HG-KR23(B)G1 1/5		
	HF-KP23(B)G1 1/12	HG-KR23(B)G1 1/12 ◆		
	HF-KP23(B)G1 1/20	HG-KR23(B)G1 1/20 ◆		
	HF-KP43(B)G1 1/5	HG-KR43(B)G1 1/5		
	HF-KP43(B)G1 1/12	HG-KR43(B)G1 1/12 ◆		
	HF-KP43(B)G1 1/20	HG-KR43(B)G1 1/20 ◆		
	HF-KP73(B)G1 1/5	HG-KR73(B)G1 1/5		
	HF-KP73(B)G1 1/12	HG-KR73(B)G1 1/12 ◆		
HF-KP73(B)G1 1/20	HG-KR73(B)G1 1/20			

Part 9: Review on Replacement of Motor

(2) HF-KP series (With reduction gear for precision application compliant)

Series	Model	Example of replacement model	Compatibility (O: Compatible)	Note
Small capacity, low inertia HF-KP series Flange-mounting flange output type for precision application compliant: G5	HF-KP053(B)G5 1/5	HG-KR053(B)G5 1/5	O	
	HF-KP053(B)G5 1/11	HG-KR053(B)G5 1/11		
	HF-KP053(B)G5 1/21	HG-KR053(B)G5 1/21		
	HF-KP053(B)G5 1/33	HG-KR053(B)G5 1/33		
	HF-KP053(B)G5 1/45	HG-KR053(B)G5 1/45		
	HF-KP13(B)G5 1/5	HG-KR13(B)G5 1/5		
	HF-KP13(B)G5 1/11	HG-KR13(B)G5 1/11		
	HF-KP13(B)G5 1/21	HG-KR13(B)G5 1/21		
	HF-KP13(B)G5 1/33	HG-KR13(B)G5 1/33		
	HF-KP13(B)G5 1/45	HG-KR13(B)G5 1/45		
	HF-KP23(B)G5 1/5	HG-KR23(B)G5 1/5		
	HF-KP23(B)G5 1/11	HG-KR23(B)G5 1/11		
	HF-KP23(B)G5 1/21	HG-KR23(B)G5 1/21		
	HF-KP23(B)G5 1/33	HG-KR23(B)G5 1/33		
	HF-KP23(B)G5 1/45	HG-KR23(B)G5 1/45		
	HF-KP43(B)G5 1/5	HG-KR43(B)G5 1/5		
	HF-KP43(B)G5 1/11	HG-KR43(B)G5 1/11		
	HF-KP43(B)G5 1/21	HG-KR43(B)G5 1/21		
	HF-KP43(B)G5 1/33	HG-KR43(B)G5 1/33		
	HF-KP43(B)G5 1/45	HG-KR43(B)G5 1/45		
	HF-KP73(B)G5 1/5	HG-KR73(B)G5 1/5		
HF-KP73(B)G5 1/11	HG-KR73(B)G5 1/11			
HF-KP73(B)G5 1/21	HG-KR73(B)G5 1/21			
HF-KP73(B)G5 1/33	HG-KR73(B)G5 1/33			
HF-KP73(B)G5 1/45	HG-KR73(B)G5 1/45			
Small capacity, low inertia HF-KP series Flange-mounting shaft output type for precision application compliant: G7	HF-KP053(B)G7 1/5	HG-KR053(B)G7 1/5	O	
	HF-KP053(B)G7 1/11	HG-KR053(B)G7 1/11		
	HF-KP053(B)G7 1/21	HG-KR053(B)G7 1/21		
	HF-KP053(B)G7 1/33	HG-KR053(B)G7 1/33		
	HF-KP053(B)G7 1/45	HG-KR053(B)G7 1/45		
	HF-KP13(B)G7 1/5	HG-KR13(B)G7 1/5		
	HF-KP13(B)G7 1/11	HG-KR13(B)G7 1/11		
	HF-KP13(B)G7 1/21	HG-KR13(B)G7 1/21		
	HF-KP13(B)G7 1/33	HG-KR13(B)G7 1/33		
	HF-KP13(B)G7 1/45	HG-KR13(B)G7 1/45		
	HF-KP23(B)G7 1/5	HG-KR23(B)G7 1/5		
	HF-KP23(B)G7 1/11	HG-KR23(B)G7 1/11		
	HF-KP23(B)G7 1/21	HG-KR23(B)G7 1/21		
	HF-KP23(B)G7 1/33	HG-KR23(B)G7 1/33		
	HF-KP23(B)G7 1/45	HG-KR23(B)G7 1/45		
	HF-KP43(B)G7 1/5	HG-KR43(B)G7 1/5		
	HF-KP43(B)G7 1/11	HG-KR43(B)G7 1/11		
	HF-KP43(B)G7 1/21	HG-KR43(B)G7 1/21		
	HF-KP43(B)G7 1/33	HG-KR43(B)G7 1/33		
	HF-KP43(B)G7 1/45	HG-KR43(B)G7 1/45		
	HF-KP73(B)G7 1/5	HG-KR73(B)G7 1/5		
HF-KP73(B)G7 1/11	HG-KR73(B)G7 1/11			
HF-KP73(B)G7 1/21	HG-KR73(B)G7 1/21			
HF-KP73(B)G7 1/33	HG-KR73(B)G7 1/33			
HF-KP73(B)G7 1/45	HG-KR73(B)G7 1/45			

Part 9: Review on Replacement of Motor

(3) HF-MP series (With gears for general industrial machines)

Series	Model	Example of replacement model	Compatibility (O: Compatible)	Note
Small capacity, ultralow inertia HF-MP series Standard/With brake	HF-MP053(B)	HG-MR053(B)	○	
	HF-MP13(B)	HG-MR13(B)		
	HF-MP23(B)	HG-MR23(B)		
	HF-MP43(B)	HG-MR43(B)		
	HF-MP73(B)	HG-MR73(B)		
Small capacity, ultralow inertia HF-MP series With gears for general industrial machines: G1	HF-MP053(B)G1 1/5	HG-KR053(B)G1 1/5	○	<ul style="list-style-type: none"> • The HG-MR series does not support the geared model. The geared model is supported with the HG-KR series. • Because the reduction gears of models marked with ◆ are different from the actual reduction ratio, it is required that an electronic gear be set up. Refer to "2.4 Comparison of actual reduction ratios for geared servo motors" for the details.
	HF-MP053(B)G1 1/12	HG-KR053(B)G1 1/12		
	HF-MP053(B)G1 1/20	HG-KR053(B)G1 1/20		
	HF-MP13(B)G1 1/5	HG-KR13(B)G1 1/5		
	HF-MP13(B)G1 1/12	HG-KR13(B)G1 1/12		
	HF-MP13(B)G1 1/20	HG-KR13(B)G1 1/20		
	HF-MP23(B)G1 1/5	HG-KR23(B)G1 1/5		
	HF-MP23(B)G1 1/12	HG-KR23(B)G1 1/12 ◆		
	HF-MP23(B)G1 1/20	HG-KR23(B)G1 1/20 ◆		
	HF-MP43(B)G1 1/5	HG-KR43(B)G1 1/5		
	HF-MP43(B)G1 1/12	HG-KR43(B)G1 1/12 ◆		
	HF-MP43(B)G1 1/20	HG-KR43(B)G1 1/20 ◆		
	HF-MP73(B)G1 1/5	HG-KR73(B)G1 1/5		
	HF-MP73(B)G1 1/12	HG-KR73(B)G1 1/12 ◆		
HF-MP73(B)G1 1/20	HG-KR73(B)G1 1/20			

Part 9: Review on Replacement of Motor

(4) HF-MP series (With reduction gear for precision application compliant)

Series	Model	Example of replacement model	Compatibility (O: Compatible)	Note
Small capacity, ultralow inertia HF-MP series With flange-output type gear reducer for high precision applications, flange mounting: G5	HF-MP053(B)G5 1/5	HG-KR053(B)G5 1/5	O	<ul style="list-style-type: none"> The HG-MR series does not support the geared model. The geared model is supported with the HG-KR series.
	HF-MP053(B)G5 1/11	HG-KR053(B)G5 1/11		
	HF-MP053(B)G5 1/21	HG-KR053(B)G5 1/21		
	HF-MP053(B)G5 1/33	HG-KR053(B)G5 1/33		
	HF-MP053(B)G5 1/45	HG-KR053(B)G5 1/45		
	HF-MP13(B)G5 1/5	HG-KR13(B)G5 1/5		
	HF-MP13(B)G5 1/11	HG-KR13(B)G5 1/11		
	HF-MP13(B)G5 1/21	HG-KR13(B)G5 1/21		
	HF-MP13(B)G5 1/33	HG-KR13(B)G5 1/33		
	HF-MP13(B)G5 1/45	HG-KR13(B)G5 1/45		
	HF-MP23(B)G5 1/5	HG-KR23(B)G5 1/5		
	HF-MP23(B)G5 1/11	HG-KR23(B)G5 1/11		
	HF-MP23(B)G5 1/21	HG-KR23(B)G5 1/21		
	HF-MP23(B)G5 1/33	HG-KR23(B)G5 1/33		
	HF-MP23(B)G5 1/45	HG-KR23(B)G5 1/45		
	HF-MP43(B)G5 1/5	HG-KR43(B)G5 1/5		
	HF-MP43(B)G5 1/11	HG-KR43(B)G5 1/11		
	HF-MP43(B)G5 1/21	HG-KR43(B)G5 1/21		
	HF-MP43(B)G5 1/33	HG-KR43(B)G5 1/33		
	HF-MP43(B)G5 1/45	HG-KR43(B)G5 1/45		
HF-MP73(B)G5 1/5	HG-KR73(B)G5 1/5			
HF-MP73(B)G5 1/11	HG-KR73(B)G5 1/11			
HF-MP73(B)G5 1/21	HG-KR73(B)G5 1/21			
HF-MP73(B)G5 1/33	HG-KR73(B)G5 1/33			
HF-MP73(B)G5 1/45	HG-KR73(B)G5 1/45			
Small capacity, ultralow inertia HF-MP series With flange-output type gear reducer for high precision applications, flange mounting: G7	HF-MP053(B)G7 1/5	HG-KR053(B)G7 1/5	O	<ul style="list-style-type: none"> The HG-MR series does not support the geared model. The geared model is supported with the HG-KR series.
	HF-MP053(B)G7 1/11	HG-KR053(B)G7 1/11		
	HF-MP053(B)G7 1/21	HG-KR053(B)G7 1/21		
	HF-MP053(B)G7 1/33	HG-KR053(B)G7 1/33		
	HF-MP053(B)G7 1/45	HG-KR053(B)G7 1/45		
	HF-MP13(B)G7 1/5	HG-KR13(B)G7 1/5		
	HF-MP13(B)G7 1/11	HG-KR13(B)G7 1/11		
	HF-MP13(B)G7 1/21	HG-KR13(B)G7 1/21		
	HF-MP13(B)G7 1/33	HG-KR13(B)G7 1/33		
	HF-MP13(B)G7 1/45	HG-KR13(B)G7 1/45		
	HF-MP23(B)G7 1/5	HG-KR23(B)G7 1/5		
	HF-MP23(B)G7 1/11	HG-KR23(B)G7 1/11		
	HF-MP23(B)G7 1/21	HG-KR23(B)G7 1/21		
	HF-MP23(B)G7 1/33	HG-KR23(B)G7 1/33		
	HF-MP23(B)G7 1/45	HG-KR23(B)G7 1/45		
	HF-MP43(B)G7 1/5	HG-KR43(B)G7 1/5		
	HF-MP43(B)G7 1/11	HG-KR43(B)G7 1/11		
	HF-MP43(B)G7 1/21	HG-KR43(B)G7 1/21		
	HF-MP43(B)G7 1/33	HG-KR43(B)G7 1/33		
	HF-MP43(B)G7 1/45	HG-KR43(B)G7 1/45		
HF-MP73(B)G7 1/5	HG-KR73(B)G7 1/5			
HF-MP73(B)G7 1/11	HG-KR73(B)G7 1/11			
HF-MP73(B)G7 1/21	HG-KR73(B)G7 1/21			
HF-MP73(B)G7 1/33	HG-KR73(B)G7 1/33			
HF-MP73(B)G7 1/45	HG-KR73(B)G7 1/45			

Part 9: Review on Replacement of Motor

(5) HF-SP series (With gears for general industrial machines)

Series	Model	Example of replacement model	Compatibility (O: Compatible)	Note
Medium capacity, medium inertia HF-SP series Standard/With brake	HF-SP51(B)	HG-SR51(B)	O	
	HF-SP81(B)	HG-SR81(B)		
	HF-SP121(B)	HG-SR121(B)		
	HF-SP201(B)	HG-SR201(B)		
	HF-SP301(B)	HG-SR301(B)		
	HF-SP421(B)	HG-SR421(B)		
	HF-SP52(4)(B)	HG-SR52(4)(B)		
	HF-SP102(4)(B)	HG-SR102(4)(B)		
	HF-SP152(4)(B)	HG-SR152(4)(B)		
	HF-SP202(4)(B)	HG-SR202(4)(B)		
	HF-SP352(4)(B)	HG-SR352(4)(B)		
	HF-SP502(4)(B)	HG-SR502(4)(B)		
	HF-SP702(4)(B)	HG-SR702(4)(B)		
	Medium capacity, medium inertia HF-SP series With gears for general industrial machines: G1	HF-SP52(4)(B)G1(H) 1/6		
HF-SP52(4)(B)G1(H) 1/11		HG-SR52(4)(B)G1(H) 1/11		
HF-SP52(4)(B)G1(H) 1/17		HG-SR52(4)(B)G1(H) 1/17		
HF-SP52(4)(B)G1(H) 1/29		HG-SR52(4)(B)G1(H) 1/29		
HF-SP52(4)(B)G1(H) 1/35		HG-SR52(4)(B)G1(H) 1/35		
HF-SP52(4)(B)G1(H) 1/43		HG-SR52(4)(B)G1(H) 1/43		
HF-SP52(4)(B)G1(H) 1/59		HG-SR52(4)(B)G1(H) 1/59		
HF-SP102(4)(B)G1(H) 1/6		HG-SR102(4)(B)G1(H) 1/6		
HF-SP102(4)(B)G1(H) 1/11		HG-SR102(4)(B)G1(H) 1/11		
HF-SP102(4)(B)G1(H) 1/17		HG-SR102(4)(B)G1(H) 1/17		
HF-SP102(4)(B)G1(H) 1/29		HG-SR102(4)(B)G1(H) 1/29		
HF-SP102(4)(B)G1(H) 1/35		HG-SR102(4)(B)G1(H) 1/35		
HF-SP102(4)(B)G1(H) 1/43		HG-SR102(4)(B)G1(H) 1/43		
HF-SP102(4)(B)G1(H) 1/59		HG-SR102(4)(B)G1(H) 1/59		
HF-SP152(4)(B)G1(H) 1/6		HG-SR152(4)(B)G1(H) 1/6		
HF-SP152(4)(B)G1(H) 1/11		HG-SR152(4)(B)G1(H) 1/11		
HF-SP152(4)(B)G1(H) 1/17		HG-SR152(4)(B)G1(H) 1/17		
HF-SP152(4)(B)G1(H) 1/29		HG-SR152(4)(B)G1(H) 1/29		
HF-SP152(4)(B)G1(H) 1/35		HG-SR152(4)(B)G1(H) 1/35		
HF-SP152(4)(B)G1(H) 1/43		HG-SR152(4)(B)G1(H) 1/43		
HF-SP152(4)(B)G1(H) 1/59		HG-SR152(4)(B)G1(H) 1/59		
HF-SP202(4)(B)G1(H) 1/6		HG-SR202(4)(B)G1(H) 1/6		
HF-SP202(4)(B)G1(H) 1/11		HG-SR202(4)(B)G1(H) 1/11		
HF-SP202(4)(B)G1(H) 1/17		HG-SR202(4)(B)G1(H) 1/17		
HF-SP202(4)(B)G1(H) 1/29		HG-SR202(4)(B)G1(H) 1/29		
HF-SP202(4)(B)G1(H) 1/35		HG-SR202(4)(B)G1(H) 1/35		
HF-SP202(4)(B)G1(H) 1/43		HG-SR202(4)(B)G1(H) 1/43		
HF-SP202(4)(B)G1(H) 1/59		HG-SR202(4)(B)G1(H) 1/59		
HF-SP352(4)(B)G1(H) 1/6		HG-SR352(4)(B)G1(H) 1/6		
HF-SP352(4)(B)G1(H) 1/11		HG-SR352(4)(B)G1(H) 1/11		
HF-SP352(4)(B)G1(H) 1/17		HG-SR352(4)(B)G1(H) 1/17		
HF-SP352(4)(B)G1(H) 1/29		HG-SR352(4)(B)G1(H) 1/29		
HF-SP352(4)(B)G1(H) 1/35		HG-SR352(4)(B)G1(H) 1/35		
HF-SP352(4)(B)G1(H) 1/43		HG-SR352(4)(B)G1(H) 1/43		
HF-SP352(4)(B)G1(H) 1/59	HG-SR352(4)(B)G1(H) 1/59			

Part 9: Review on Replacement of Motor

(6) HF-SP series (With gears for general industrial machines/With flange-output type gear reducer for high precision applications, flange mounting)

Series	Model	Example of replacement model	Compatibility (O: Compatible)	Note
Medium capacity, medium inertia HF-SP series With gears for general industrial machines with a reducer G1	HF-SP502(4)(B)G1(H) 1/6	HG-SR502(4)(B)G1(H) 1/6	O	
	HF-SP502(4)(B)G1(H) 1/11	HG-SR502(4)(B)G1(H) 1/11		
	HF-SP502(4)(B)G1(H) 1/17	HG-SR502(4)(B)G1(H) 1/17		
	HF-SP502(4)(B)G1(H) 1/29	HG-SR502(4)(B)G1(H) 1/29		
	HF-SP502(4)(B)G1(H) 1/35	HG-SR502(4)(B)G1(H) 1/35		
	HF-SP502(4)(B)G1(H) 1/43	HG-SR502(4)(B)G1(H) 1/43		
	HF-SP502(4)(B)G1(H) 1/59	HG-SR502(4)(B)G1(H) 1/59		
	HF-SP702(4)(B)G1(H) 1/6	HG-SR702(4)(B)G1(H) 1/6		
	HF-SP702(4)(B)G1(H) 1/11	HG-SR702(4)(B)G1(H) 1/11		
	HF-SP702(4)(B)G1(H) 1/17	HG-SR702(4)(B)G1(H) 1/17		
	HF-SP702(4)(B)G1(H) 1/29	HG-SR702(4)(B)G1(H) 1/29		
	HF-SP702(4)(B)G1(H) 1/35	HG-SR702(4)(B)G1(H) 1/35		
	HF-SP702(4)(B)G1(H) 1/43	HG-SR702(4)(B)G1(H) 1/43		
	HF-SP702(4)(B)G1(H) 1/59	HG-SR702(4)(B)G1(H) 1/59		
Medium capacity, medium inertia HF-SP series With flange-output type gear reducer for high precision applications, flange mounting: G5	HF-SP52(4)(B)G5 1/5	HG-SR52(4)(B)G5 1/5	O	
	HF-SP52(4)(B)G5 1/11	HG-SR52(4)(B)G5 1/11		
	HF-SP52(4)(B)G5 1/21	HG-SR52(4)(B)G5 1/21		
	HF-SP52(4)(B)G5 1/33	HG-SR52(4)(B)G5 1/33		
	HF-SP52(4)(B)G5 1/45	HG-SR52(4)(B)G5 1/45		
	HF-SP102(4)(B)G5 1/5	HG-SR102(4)(B)G5 1/5		
	HF-SP102(4)(B)G5 1/11	HG-SR102(4)(B)G5 1/11		
	HF-SP102(4)(B)G5 1/21	HG-SR102(4)(B)G5 1/21		
	HF-SP102(4)(B)G5 1/33	HG-SR102(4)(B)G5 1/33		
	HF-SP102(4)(B)G5 1/45	HG-SR102(4)(B)G5 1/45		
	HF-SP152(4)(B)G5 1/5	HG-SR152(4)(B)G5 1/5		
	HF-SP152(4)(B)G5 1/11	HG-SR152(4)(B)G5 1/11		
	HF-SP152(4)(B)G5 1/21	HG-SR152(4)(B)G5 1/21		
	HF-SP152(4)(B)G5 1/33	HG-SR152(4)(B)G5 1/33		
	HF-SP152(4)(B)G5 1/45	HG-SR152(4)(B)G5 1/45		
	HF-SP202(4)(B)G5 1/5	HG-SR202(4)(B)G5 1/5		
	HF-SP202(4)(B)G5 1/11	HG-SR202(4)(B)G5 1/11		
	HF-SP202(4)(B)G5 1/21	HG-SR202(4)(B)G5 1/21		
	HF-SP202(4)(B)G5 1/33	HG-SR202(4)(B)G5 1/33		
	HF-SP202(4)(B)G5 1/45	HG-SR202(4)(B)G5 1/45		
HF-SP352(4)(B)G5 1/5	HG-SR352(4)(B)G5 1/5			
HF-SP352(4)(B)G5 1/11	HG-SR352(4)(B)G5 1/11			
HF-SP352(4)(B)G5 1/21	HG-SR352(4)(B)G5 1/21			
HF-SP502(4)(B)G5 1/5	HG-SR502(4)(B)G5 1/5			
HF-SP502(4)(B)G5 1/11	HG-SR502(4)(B)G5 1/11			
HF-SP702(4)(B)G5 1/5	HG-SR702(4)(B)G5 1/5			

• The total length of the motor will be shorter, so confirm that the motor connector does not interfere with the device side.

Part 9: Review on Replacement of Motor

(7) HF-SP series (With shaft-output type gear reducer for high precision applications)

Series	Model	Example of replacement model	Compatibility (O: Compatible)	Note
Medium capacity, medium inertia HF-SP series With shaft-output type gear reducer for high precision applications, flange mounting: G7	HF-SP52(4)(B)G7 1/5	HG-SR52(4)(B)G7 1/5	O	<ul style="list-style-type: none"> The total length of the motor will be shorter, so confirm that the motor connector does not interfere with the device side.
	HF-SP52(4)(B)G7 1/11	HG-SR52(4)(B)G7 1/11		
	HF-SP52(4)(B)G7 1/21	HG-SR52(4)(B)G7 1/21		
	HF-SP52(4)(B)G7 1/33	HG-SR52(4)(B)G7 1/33		
	HF-SP52(4)(B)G7 1/45	HG-SR52(4)(B)G7 1/45		
	HF-SP102(4)(B)G7 1/5	HG-SR102(4)(B)G7 1/5		
	HF-SP102(4)(B)G7 1/11	HG-SR102(4)(B)G7 1/11		
	HF-SP102(4)(B)G7 1/21	HG-SR102(4)(B)G7 1/21		
	HF-SP102(4)(B)G7 1/33	HG-SR102(4)(B)G7 1/33		
	HF-SP102(4)(B)G7 1/45	HG-SR102(4)(B)G7 1/45		
	HF-SP152(4)(B)G7 1/5	HG-SR152(4)(B)G7 1/5		
	HF-SP152(4)(B)G7 1/11	HG-SR152(4)(B)G7 1/11		
	HF-SP152(4)(B)G7 1/21	HG-SR152(4)(B)G7 1/21		
	HF-SP152(4)(B)G7 1/33	HG-SR152(4)(B)G7 1/33		
	HF-SP152(4)(B)G7 1/45	HG-SR152(4)(B)G7 1/45		
	HF-SP202(4)(B)G7 1/5	HG-SR202(4)(B)G7 1/5		
	HF-SP202(4)(B)G7 1/11	HG-SR202(4)(B)G7 1/11		
	HF-SP202(4)(B)G7 1/21	HG-SR202(4)(B)G7 1/21		
	HF-SP202(4)(B)G7 1/33	HG-SR202(4)(B)G7 1/33		
	HF-SP202(4)(B)G7 1/45	HG-SR202(4)(B)G7 1/45		
	HF-SP352(4)(B)G7 1/5	HG-SR352(4)(B)G7 1/5		
	HF-SP352(4)(B)G7 1/11	HG-SR352(4)(B)G7 1/11		
	HF-SP352(4)(B)G7 1/21	HG-SR352(4)(B)G7 1/21		
HF-SP502(4)(B)G7 1/5	HG-SR502(4)(B)G7 1/5			
HF-SP502(4)(B)G7 1/11	HG-SR502(4)(B)G7 1/11			
HF-SP702(4)(B)G7 1/5	HG-SR702(4)(B)G7 1/5			

Part 9: Review on Replacement of Motor

(8) HC-RP series

Series	model	Example of replacement model	Compatibility (O: Compatible)	Note
Medium capacity, ultra-low inertia HC-RP series	HC-RP103(B)	HG-RR103(B)	O	
	HC-RP153(B)	HG-RR153(B)		
	HC-RP203(B)	HG-RR203(B)		
	HC-RP353(B)	HG-RR353(B)		
	HC-RP503(B)	HG-RR503(B)		
Medium capacity, ultra-low inertia HC-RP series With flange-output type gear reducer for high precision applications, flange mounting: G5	HC-RP103(B)G5 1/5◇	HG-SR102(B)G5 1/5	(Note)	<ul style="list-style-type: none"> The HG-RR series does not support the geared model. The geared model is supported with the HG-SR series. Check the output torque because the reduction ratio of models marked with ◆ is greatly different. The capacity of the corresponding servo amplifier will be different if a model marked with ◇ is replaced. The corresponding servo amplifier for HG-SR102 is MR-J4-100_(-RJ), for HG-SR202 is MR-J4-200_(-RJ), and for HG-SR352 is MR-J4-350_(-RJ).
	HC-RP103(B)G5 1/11◇	HG-SR102(B)G5 1/11		
	HC-RP103(B)G5 1/21◇	HG-SR102(B)G5 1/21		
	HC-RP103(B)G5 1/33◇	HG-SR102(B)G5 1/33		
	HC-RP103(B)G5 1/45◇	HG-SR102(B)G5 1/45		
	HC-RP153(B)G5 1/5	HG-SR152(B)G5 1/5		
	HC-RP153(B)G5 1/11	HG-SR152(B)G5 1/11		
	HC-RP153(B)G5 1/21	HG-SR152(B)G5 1/21		
	HC-RP153(B)G5 1/33	HG-SR152(B)G5 1/33		
	HC-RP153(B)G5 1/45	HG-SR152(B)G5 1/45		
	HC-RP203(B)G5 1/5◇	HG-SR202(B)G5 1/5		
	HC-RP203(B)G5 1/11◇	HG-SR202(B)G5 1/11		
	HC-RP203(B)G5 1/21◇	HG-SR202(B)G5 1/21		
	HC-RP203(B)G5 1/33◇	HG-SR202(B)G5 1/33		
	HC-RP203(B)G5 1/45◇	HG-SR202(B)G5 1/45		
	HC-RP353(B)G5 1/5◇	HG-SR352(B)G5 1/5		
	HC-RP353(B)G5 1/11◇	HG-SR352(B)G5 1/11		
	HC-RP353(B)G5 1/21◇	HG-SR352(B)G5 1/21		
	HC-RP353(B)G5 1/33◇	HG-SR352(B)G5 1/21 ◆		
	HC-RP503(B)G5 1/5	HG-SR502(B)G5 1/5		
HC-RP503(B)G5 1/11	HG-SR502(B)G5 1/11			
HC-RP503(B)G5 1/21	HG-SR502(B)G5 1/11 ◆			
Medium capacity, ultra-low inertia HC-RP series With shaft-output type gear reducer for high precision applications, flange mounting: G7	HC-RP103(B)G7 1/5◇	HG-SR102(B)G7 1/5	(Note)	
	HC-RP103(B)G7 1/11◇	HG-SR102(B)G7 1/11		
	HC-RP103(B)G7 1/21◇	HG-SR102(B)G7 1/21		
	HC-RP103(B)G7 1/33◇	HG-SR102(B)G7 1/33		
	HC-RP103(B)G7 1/45◇	HG-SR102(B)G7 1/45		
	HC-RP153(B)G7 1/5	HG-SR152(B)G7 1/5		
	HC-RP153(B)G7 1/11	HG-SR152(B)G7 1/11		
	HC-RP153(B)G7 1/21	HG-SR152(B)G7 1/21		
	HC-RP153(B)G7 1/33	HG-SR152(B)G7 1/33		
	HC-RP153(B)G7 1/45	HG-SR152(B)G7 1/45		
	HC-RP203(B)G7 1/5◇	HG-SR202(B)G7 1/5		
	HC-RP203(B)G7 1/11◇	HG-SR202(B)G7 1/11		
	HC-RP203(B)G7 1/21◇	HG-SR202(B)G7 1/21		
	HC-RP203(B)G7 1/33◇	HG-SR202(B)G7 1/33		
	HC-RP203(B)G7 1/45◇	HG-SR202(B)G7 1/45		
	HC-RP353(B)G7 1/5◇	HG-SR352(B)G7 1/5		
	HC-RP353(B)G7 1/11◇	HG-SR352(B)G7 1/11		
	HC-RP353(B)G7 1/21◇	HG-SR352(B)G7 1/21		
	HC-RP353(B)G7 1/33◇	HG-SR352(B)G7 1/21 ◆		
	HC-RP503(B)G7 1/5	HG-SR502(B)G7 1/5		
HC-RP503(B)G7 1/11	HG-SR502(B)G7 1/11			
HC-RP503(B)G7 1/21	HG-SR502(B)G7 1/11 ◆			

Note. For mounting dimensions, refer to "2.3 Comparison of Mounting Dimensions for Geared Servo Motors".

Part 9: Review on Replacement of Motor

(9) HC-LP/HC-UP/HF-JP series

Series	model	Example of replacement model	Compatibility (O: Compatible)	Note
Medium capacity, low inertia HC-LP series	HC-LP52(B) ◇	HG-JR73(B)	(Note)	<ul style="list-style-type: none"> The capacity of the corresponding servo amplifier will be different if a model marked with ◇ is replaced. HG-JR73 is MR-J4-70_(-RJ), HG-JR153 is MR-J4-200_(-RJ), HG-JR353 is MR-J4-350_(-RJ). Check the dimensions and others of the servo amplifier (drive unit) since the capacity is changed. Models shown with "◆" do not have supporting multi-axis amplifiers. The power supply and electromagnetic brake connector differ. For further details, refer to "2.6 Comparison of Servo Motor Connector Specifications".
	HC-LP102(B) ◇	HG-JR153(B) ◆		
	HC-LP152(B) ◇	HG-JR353(B)		
	HC-LP202(B)	HG-JR353(B)		
	HC-LP302(B)	HG-JR503(B)		
Medium capacity, flat type HC-UP series	HC-UP72(B)	HG-UR72(B)	O	/
	HC-UP152(B)	HG-UR152(B)		
	HC-UP202(B)	HG-UR202(B)		
	HC-UP352(B)	HG-UR352(B)		
	HC-UP502(B)	HG-UR502(B)		
Large capacity, low inertia HF-JP series	HF-JP53(4)(B)	HG-JR53(4)(B)	O	/
	HF-JP73(4)(B)	HG-JR73(4)(B)		
	HF-JP103(4)(B)	HG-JR103(4)(B)		
	HF-JP153(4)(B)	HG-JR153(4)(B)		
	HF-JP203(4)(B)	HG-JR203(4)(B)		
	HF-JP353(4)(B)	HG-JR353(4)(B)		
	HF-JP503(4)(B)	HG-JR503(4)(B)		
	HF-JP703(4)(B)	HG-JR703(4)(B)		
	HF-JP903(4)(B)	HG-JR903(4)(B)		
	HF-JP11K1M(4)(B)	HG-JR11K1M(4)(B)		
	HF-JP15K1M(4)(B)	HG-JR15K1M(4)(B)		

Note. For mounting dimensions, Refer to "2.2 Detailed comparison of servo motor mounting dimensions."

Part 9: Review on Replacement of Motor

(10) HA-LP series

Series	Model	Example of replacement model	Compatibility (O: Compatible)	Note
Large capacity, low inertia HA-LP 1000 r/min series	HA-LP601(4)(B)	HG-JR601(4)(B)	(Note 1)	<ul style="list-style-type: none"> Replacement from a model marked with ◇ requires a new encoder cable wiring because the motor thermal wiring differs. The capacity of the corresponding drive unit will be different if a model marked with ◆ is replaced. HG-JR25K14 is MR-J4-22K_4(-RJ) or MR-J4-DU22KB4(-RJ), HG-JR22K1M(4) is MR-J4-22K_(4)(-RJ) or MR-J4-DU22KB(4), HG-JR30K1M(4) is MR-J4-DU30K_(4), HG-JR37K1M4 is MR-J4-DU37K_4, HG-JR45K1M4 is MR-J4-DU45K_4. When replacing to MR-J4-DU22KB(4), refer to the manufacturer catalog and instruction manual. Only MR-CV is available to MR-J4-DU22KB(4). Check the dimensions and others of the servo amplifier (drive unit) since the capacity is changed.
	HA-LP801(4)(B)	HG-JR801(4)(B)		
	HA-LP12K1(4)(B)	HG-JR12K1(4)(B)		
	HA-LP15K1(4) ◇	HG-JR15K1(4)		
	HA-LP20K1(4) ◇	HG-JR20K1(4)		
	HA-LP25K1(4) ◇ ◆	HG-JR25K1(4)		
	HA-LP30K1(4) ◇	HG-JR30K1(4)		
	HA-LP37K1(4) ◇	HG-JR37K1(4)	O (Note 2)	
	HA-LP601(4)(B)	HG-JR601(4)R(B)-S_		
	HA-LP801(4)(B)	HG-JR801(4)R(B)-S_		
	HA-LP12K1(4)(B)	HG-JR12K1(4)R(B)-S_		
	HA-LP15K1(4) ◇	HG-JR15K1(4)R-S_		
	HA-LP20K1(4) ◇	HG-JR20K1(4)R-S_		
	HA-LP25K1(4) ◇ ◆	HG-JR25K1(4)R-S_		
HA-LP30K1(4) ◇	HG-JR30K1(4)R-S_			
HA-LP37K1(4) ◇	HG-JR37K1(4)R-S_			
Large capacity, low inertia HA-LP 1500 r/min series	HA-LP701M(4)(B)	HG-JR701M(4)(B)	(Note 1)	
	HA-LP11K1M(4)(B)	HG-JR11K1M(4)(B)		
	HA-LP15K1M(4)(B)	HG-JR15K1M(4)(B)		
	HA-LP22K1M(4) ◇	HG-JR22K1M(4)		
	HA-LP30K1M(4) ◇	HG-JR30K1M(4)		
	HA-LP37K1M(4) ◇	HG-JR37K1M(4)		
	HA-LP45K1M4 ◇	HG-JR45K1M4		
	HA-LP50K1M4 ◇	HG-JR55K1M4	O (Note 2)	
	HA-LP701M(4)(B)	HG-JR701M(4)R(B)-S_		
	HA-LP11K1M(4)(B)	HG-JR11K1M(4)R(B)-S_(□250)		
	HA-LP15K1M(4)(B)	HG-JR15K1M(4)R(B)-S_		
	HA-LP22K1M(4) ◇	HG-JR22K1M(4)R-S_		
	HA-LP30K1M(4) ◇	HG-JR30K1M(4)R-S_		
	HA-LP37K1M(4) ◇	HG-JR37K1M(4)R-S_		
HA-LP45K1M4 ◇	HG-JR45K1M4R-S_			
HA-LP50K1M4 ◇	HG-JR55K1M4R-S_			
Large capacity, low inertia HA-LP 2000 r/min series	HA-LP502	HG-SR502	(Note 1)	
	HA-LP702	HG-SR702		
	HA-LP11K2(4)(B)	HG-JR11K1M(4)(B)		
	HA-LP15K2(4)(B)			
	HA-LP22K2(4)(B)	HG-JR15K1M(4)(B)		
	HA-LP30K2(4) ◇ ◆	HG-JR22K1M(4)		
	HA-LP37K2(4) ◇ ◆	HG-JR30K1M(4)		
	HA-LP45K24 ◇ ◆	HG-JR37K1M4		
	HA-LP55K24 ◇ ◆	HG-JR45K1M4	O (Note 2)	
	HA-LP502	HG-SR502R-S_		
	HA-LP702	HG-SR702R-S_		
	HA-LP11K2(4)(B)	HG-JR11K1M(4)R(B)-S_(□200)		
	HA-LP15K2(4)(B)	HG-JR11K1M(4)R(B)-S_(□250)		
	HA-LP22K2(4)(B)	HG-JR15K1M(4)R(B)-S_		
HA-LP30K2(4) ◇ ◆	HG-JR22K1M(4)R-S_			
HA-LP37K2(4) ◇ ◆	HG-JR30K1M(4)R-S_			
HA-LP45K24 ◇ ◆	HG-JR37K1M4R-S_			
HA-LP55K24 ◇ ◆	HG-JR45K1M4R-S_			

Note 1. For mounting dimensions, Refer to "2.2 Detailed comparison of servo motor mounting dimensions.

2. Only flanges and shaft ends have compatibility in mounting.

Please contact your local sales office regarding the servo motor model and its delivery, since it is developed upon receipt of order.

Part 9: Review on Replacement of Motor

2. COMPARISON OF SERVO MOTOR SPECIFICATIONS

2.1 Comparison of Servo Motor Mounting Dimensions

POINT
<ul style="list-style-type: none">● As for the dimensions not listed here, refer to the catalog or instruction manual.● The symbols in the table mean as follows. (B): With brake● The value in the parenthesis shows the value with brake.

Part 9: Review on Replacement of Motor

(1) HF-KP/HF-MP/HF-SP/HC-RP series

[Unit: mm]

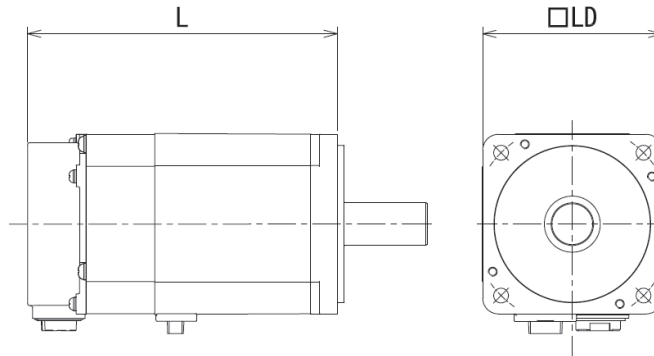

Target models			Replacement models			Note		
Model	L	LD	Example of replacement model	L	LD			
HF-KP053(B)	66.4 (107.5)	40	HG-KR053(B)	66.4 (107)	40			
HF-MP053(B)			HG-MR053(B)					
HF-KP13(B)	82.4 (123.5)		HG-KR13(B)	82.4 (123)				
HF-MP13(B)			HG-MR13(B)					
HF-KP23(B)	76.6 (116.1)	60	HG-KR23(B)	76.6 (113.4)	60		(Note)	
HF-MP23(B)			HG-MR23(B)					
HF-KP43(B)	98.5 (138)		HG-KR43(B)	98.3 (135.1)				
HF-MP43(B)			HG-MR43(B)					
HF-KP73(B)	113.8 (157)	80	HG-KR73(B)	112 (152.3)	80			
HF-MP73(B)			HG-MR73(B)					
HF-SP51(B)	140.5 (175)		130	HG-SR51(B)		132.5 (167)		130
HF-SP81(B)	162.5 (197)			HG-SR81(B)		146.5 (181)		
HF-SP121(B)	143.5 (193)	176	HG-SR121(B)	138.5 (188)	176			
HF-SP201(B)	183.5 (233)		HG-SR201(B)	162.5 (212)				
HF-SP301(B)	203.5 (253)		HG-SR301(B)	178.5 (228)				
HF-SP421(B)	263.5 (313)		HG-SR421(B)	218.5 (268)				
HF-SP52(B)	118.5 (153)	130	HG-SR52(B)	118.5 (153)	130			
HF-SP524(B)			HG-SR524(B)					
HF-SP102(B)	140.5 (175)		HG-SR102(B)	132.5 (167)				
HF-SP1024(B)			HG-SR1024(B)					
HF-SP152(B)	162.5 (197)	HG-SR152(B)	146.5 (181)					
HF-SP1524(B)		HG-SR1524(B)						
HF-SP202(B)	143.5 (193)	176	HG-SR202(B)	138.5 (188)	176			
HF-SP2024(B)			HG-SR2024(B)					
HF-SP352(B)	183.5 (233)		HG-SR352(B)	162.5 (212)				
HF-SP3524(B)			HG-SR3524(B)					
HF-SP502(B)	203.5 (253)	HG-SR502(B)	178.5 (228)					
HF-SP5024(B)		HG-SR5024(B)						
HF-SP702(B)	263.5 (313)	HG-SR702(B)	218.5 (268)					
HF-SP7024(B)		HG-SR7024(B)						
HC-RP103(B)	145.5 (183.5)	100	HG-RR103(B)	145.5 (183)	100			
HC-RP153(B)	170.5 (208.5)		HG-RR153(B)	170.5 (208)				
HC-RP203(B)	195.5 (233.5)		HG-RR203(B)	195.5 (233)				
HC-RP353(B)	215.5 (252.5)	130	HG-RR353(B)	215.5 (252)	130			
HC-RP503(B)	272.5 (309.5)		HG-RR503(B)	272.5 (309)				

Note. Some mounting dimensions have differences. Refer to "2.2 Detailed Comparison of Servo Motor Mounting Dimensions" for detailed dimensions.

Part 9: Review on Replacement of Motor

(2) HC-LP/HC-UP/HF-JP series

[Unit: mm]

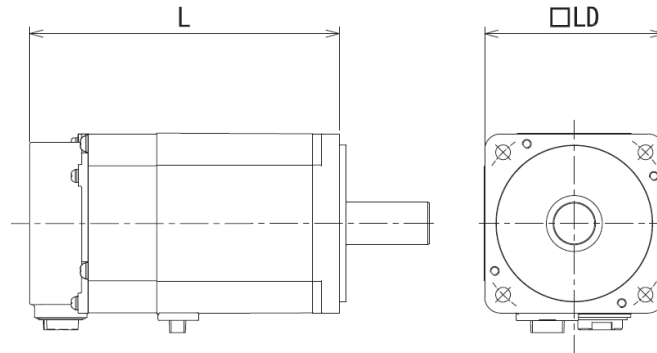

Target models			Replacement models			Note
Model	L	LD	Example of replacement model	L	LD	
HC-LP52(B)	144 (177)	130	HG-JR73(B)	145.5 (191)	90	(Note)
HC-LP102(B)	164 (197)		HG-JR153(B)	199.5 (245)		
HC-LP152(B)	191.5 (224.5)		HG-JR353(B)	213 (251.5)		
HC-LP202(B)	198.5 (246.5)	176	HG-JR353(B)	213 (251.5)	130	
HC-LP302(B)	248.5 (296.5)		HG-JR503(B)	267 (305.5)		
HC-UP72(B)	109 (142.5)	176	HG-UR72(B)	109 (142.5)	176	
HC-UP152(B)	118.5 (152)		HG-UR152(B)	118.5 (152)		
HC-UP202(B)	116.5 (159.5)	220	HG-UR202(B)	116.5 (159.5)	220	
HC-UP352(B)	140.5 (183.5)		HG-UR352(B)	140.5 (183.5)		
HC-UP502(B)	164.5 (207.5)		HG-UR502(B)	164.5 (207.5)		
HF-JP53(B)	127.5 (173)	90	HG-JR53(B)	127.5 (173)	90	
HF-JP534(B)			HG-JR534(B)			
HF-JP73(B)	145.5 (191)		HG-JR73(B)	145.5 (191)		
HF-JP734(B)			HG-JR734(B)			
HF-JP103(B)	163.5 (209)		HG-JR103(B)	163.5 (209)		
HF-JP1034(B)			HG-JR1034(B)			
HF-JP153(B)	199.5 (245)		HG-JR153(B)	199.5 (245)		
HF-JP1534(B)			HG-JR1534(B)			
HF-JP203(B)	235.5 (281)		HG-JR203(B)	235.5 (281)		
HF-JP2034(B)			HG-JR2034(B)			
HF-JP353(B)	213 (251.5)	130	HG-JR353(B)	213 (251.5)	130	
HF-JP3534(B)			HG-JR3534(B)			
HF-JP503(B)	267 (305.5)		HG-JR503(B)	267 (305.5)		
HF-JP5034(B)		HG-JR5034(B)				
HF-JP703(B)	263.5 (313)	176	HG-JR703(B)	263.5 (313)	176	
HF-JP7034(B)			HG-JR7034(B)			
HF-JP903	303.5 (353)	176	HG-JR903	303.5 (353)		
HF-JP9034(B)			HG-JR9034(B)			
HF-JP11K1M(B)	339.5 (412)	220	HG-JR11K1M(B)	339.5 (412)	220	
HF-JP11K1M4(B)			HG-JR11K1M4(B)			
HF-JP15K1M(B)	439.5 (512)	220	HG-JR15K1M(B)	439.5 (512)		
HF-JP15K1M4(B)			HG-JR15K1M4(B)			

Note. Without attachment compatibility. Refer to "2.2 Detailed Comparison of Servo Motor Mounting Dimensions" for detailed dimensions.

Part 9: Review on Replacement of Motor

(3) HA-LP 1000 r/min series

[Unit: mm]

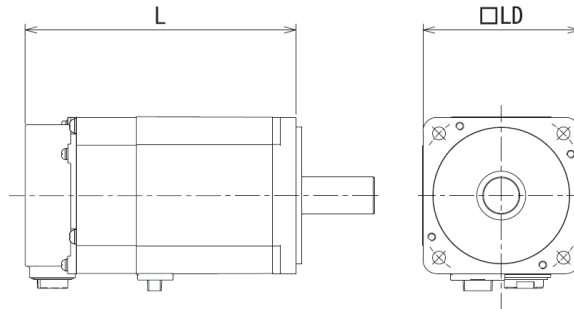

Target models			Replacement models			Note
Model	L	LD	Example of replacement model	L	LD	
HA-LP601(B) HA-LP6014(B)	480 (550)	200	HG-JR601(B) HG-JR6014(B)	299.5 (372)	220	(Note)
			HG-JR601R(B)-S_ HG-JR6014R(B)-S_	399 (472)	200	
HA-LP801(B) HA-LP8014(B)	495 (610)	250	HG-JR801(B) HG-JR8014(B)	339.5 (412)	220	(Note)
			HG-JR801R(B)-S_ HG-JR8014R(B)-S_	354 (427)	250	
HA-LP12K1(B) HA-LP12K14(B)	555 (670)	250	HG-JR12K1(B) HG-JR12K14(B)	439.5 (512)	220	(Note)
			HG-JR12K1R(B)-S_ HG-JR12K14R(B)-S_	454 (527)	250	
HA-LP15K1 HA-LP15K14	605	280	HG-JR15K1 HG-JR15K14	476	250	(Note)
			HG-JR15K1R-S_ HG-JR15K14R-S_	493	280	
HA-LP20K1 HA-LP20K14	650	280	HG-JR20K1 HG-JR20K14	538	250	(Note)
			HG-JR20K1R-S_ HG-JR20K14R-S_	555	280	
HA-LP25K1 HA-LP25K14	640	350	HG-JR25K1 HG-JR25K14	600	250	(Note)
			HG-JR25K1R-S_ HG-JR25K14R-S_	617	350	
HA-LP30K1 HA-LP30K14	685	350	HG-JR30K1 HG-JR30K14	600	280	(Note)
			HG-JR30K1R-S_ HG-JR30K14R-S_	610	350	
HA-LP37K1 HA-LP37K14	785	350	HG-JR37K1 HG-JR37K14	664	280	(Note)
			HG-JR37K1R-S_ HG-JR37K14R-S_	674	350	

Note. Without attachment compatibility. Refer to "2.2 Detailed Comparison of Servo Motor Mounting Dimensions" for detailed dimensions.

Part 9: Review on Replacement of Motor

(4) HA-LP 1500 r/min series

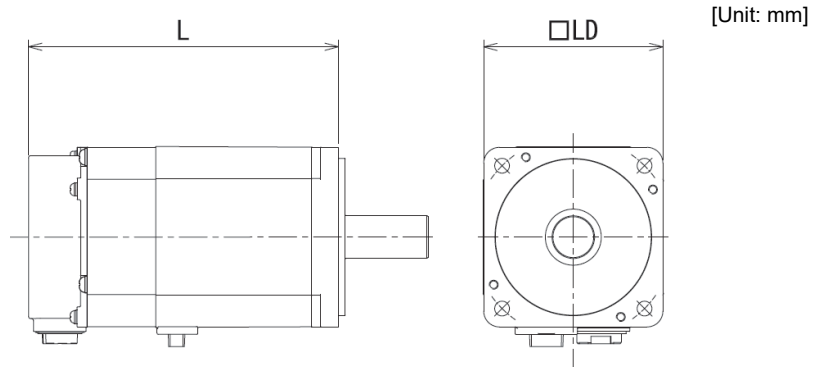

Target models			Replacement models			Note
Model	L	LD	Example of replacement model	L	LD	
HA-LP701M(B) HA-LP701M4(B)	480 (550)	200	HG-JR701M(B) HG-JR701M4(B)	299.5 (372)	220	(Note)
			HG-JR701MR(B)-S_ HG-JR701M4R(B)-S_	399 (472)	200	
HA-LP11K1M(B) HA-LP11K1M4(B)	495 (610)	250	HG-JR11K1M(B) HG-JR11K1M4(B)	339.5 (412)	220	(Note)
			HG-JR11K1MR(B)-S_(□250) HG-JR11K1M4R(B)-S_(□250)	354 (427)	250	
HA-LP15K1M(B) HA-LP15K1M4(B)	555 (670)	250	HG-JR15K1M(B) HG-JR15K1M4(B)	439.5 (512)	220	(Note)
			HG-JR15K1MR(B)-S_ HG-JR15K1M4R(B)-S_	454 (526.5)	250	
HA-LP22K1M HA-LP22K1M4	605	280	HG-JR22K1M HG-JR22K1M4	476	250	(Note)
			HG-JR22K1MR-S_ HG-JR22K1M4R-S_	493	280	
HA-LP30K1M	660	280	HG-JR30K1M	538	250	(Note)
			HG-JR30K1MR-S_	555	280	
HA-LP30K1M4	650	280	HG-JR30K1M4	538	250	(Note)
			HG-JR30K1M4R-S_	555	280	
HA-LP37K1M HA-LP37K1M4	640	350	HG-JR37K1M HG-JR37K1M4	600	250	(Note)
			HG-JR37K1MR-S_ HG-JR37K1M4R-S_	617	350	
HA-LP45K1M4	685	350	HG-JR45K1M4	600	280	(Note)
			HG-JR45K1M4R-S_	610	350	
HA-LP50K1M4	785	350	HG-JR55K1M4	664	280	(Note)
			HG-JR55K1M4R-S_	674	350	

Note. Without attachment compatibility. Refer to "2.2 Detailed Comparison of Servo Motor Mounting Dimensions" for detailed dimensions.

Part 9: Review on Replacement of Motor

(5) HA-LP 2000 r/min series

[Unit: mm]

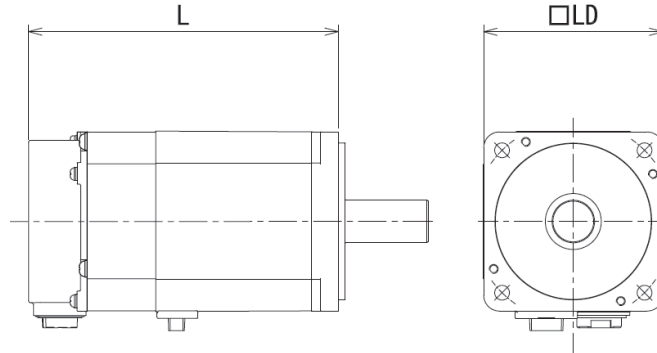

Target models			Replacement models			Note	
Model	L	LD	Example of replacement model	L	LD		
HA-LP502	298	200	HG-SR502	178.5	176	(Note)	
			HG-SR502R-S_	205	204		
HA-LP702	340		HG-SR702	218.5	176	(Note)	
			HG-SR702R-S_	245	204		
HA-LP11K2(B) HA-LP11K24(B)	480 (550)	250	HG-JR11K1M(B) HG-JR11K1M4(B)	339.5 (412)	220	(Note)	
			HG-JR11K1MR(B)-S_(□200) HG-JR11K1M4R(B)-S_(□200)	439 (512)	200		
HA-LP15K2(B) HA-LP15K24(B)	495 (610)		HG-JR11K1M(B) HG-JR11K1M4(B)	339.5 (412)	220	(Note)	
			HG-JR11K1MR(B)-S_(□250) HG-JR11K1M4R(B)-S_(□250)	354 (427)	250		
HA-LP22K2(B) HA-LP22K24(B)	555 (670)	250	HG-JR15K1M(B) HG-JR15K1M4(B)	439.5 (512)	220	(Note)	
			HG-JR15K1MR(B)-S_ HG-JR15K1M4R(B)-S_	454 (526.5)	250		
HA-LP30K2	615		280	HG-JR22K1M	476	250	(Note)
				HG-JR22K1MR-S_	493	280	
HA-LP30K24	605	HG-JR22K1M4		476	250	(Note)	
		HG-JR22K1M4R-S_		493	280		
HA-LP37K2	660	HG-JR30K1M		538	250	(Note)	
		HG-JR30K1MR-S_		555	280		
HA-LP37K24	650	HG-JR30K1M4		538	250	(Note)	
		HG-JR30K1M4R-S_		555	280		
HA-LP45K24	640	350	HG-JR37K1M4	600	250	(Note)	
			HG-JR37K1M4R-S_	617	350		
HA-LP55K24	685		HG-JR45K1M4	600	280	(Note)	
			HG-JR45K1M4R-S_	610	350		

Note. Without attachment compatibility. Refer to "2.2 Detailed Comparison of Servo Motor Mounting Dimensions" for detailed dimensions.

Part 9: Review on Replacement of Motor

2.2 Detailed Comparison of Servo Motor Mounting Dimensions

POINT
●As for the dimensions not listed here, refer to the catalog or Instruction Manual.
●Dimensions with differences are shown with shading.
●The symbols in the table mean as follows. (B): With brake

(1) HF-KP/HF-MP/HF-SP/HC-RP series

[Unit: mm]

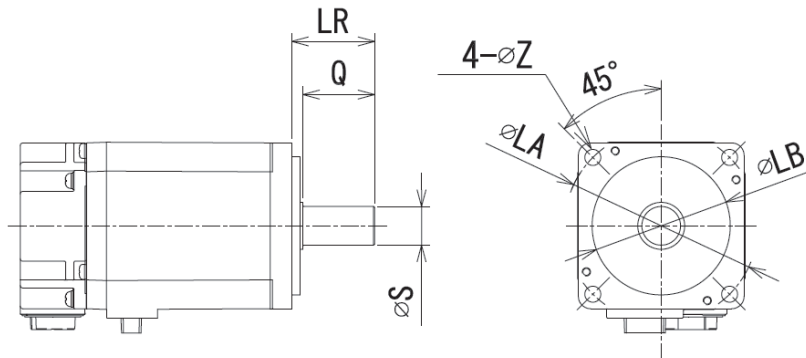

Model	Target models						Example of replacement model	Replacement models					
	LA	LB	LR	Q	S	Z		LA	LB	LR	Q	S	Z
HF-KP053(B) HF-MP053(B)	46	30	25	21.5	8	4.5	HG-KR053(B) HG-MR053(B)	46	30	25	21.5	8	4.5
HF-KP13(B) HF-MP13(B)	46	30	25	21.5	8	4.5	HG-KR13(B) HG-MR13(B)	46	30	25	21.5	8	4.5
HF-KP23(B) HF-MP23(B)	70	50	30	27	14	5.8	HG-KR23(B) HG-MR23(B)	70	50	30	26	14	5.8
HF-KP43(B) HF-MP43(B)	70	50	30	27	14	5.8	HG-KR43(B) HG-MR43(B)	70	50	30	26	14	5.8
HF-KP73(B) HF-MP73(B)	90	70	40	37	19	6.6	HG-KR73(B) HG-MR73(B)	90	70	40	36	19	6.6
HF-SP51(B)	145	110	55	50	24	9	HG-SR51(B)	145	110	55	50	24	9
HF-SP81(B)	145	110	55	50	24	9	HG-SR81(B)	145	110	55	50	24	9
HF-SP121(B)	200	114.3	79	75	35	13.5	HG-SR121(B)	200	114.3	79	75	35	13.5
HF-SP201(B)	200	114.3	79	75	35	13.5	HG-SR201(B)	200	114.3	79	75	35	13.5
HF-SP301(B)	200	114.3	79	75	35	13.5	HG-SR301(B)	200	114.3	79	75	35	13.5
HF-SP421(B)	200	114.3	79	75	35	13.5	HG-SR421(B)	200	114.3	79	75	35	13.5
HF-SP52(B) HF-SP524(B)	145	110	55	50	24	9	HG-SR52(B) HG-SR524(B)	145	110	55	50	24	9
HF-SP102(B) HF-SP1024(B)	145	110	55	50	24	9	HG-SR102(B) HG-SR1024(B)	145	110	55	50	24	9
HF-SP152(B) HF-SP1524(B)	145	110	55	50	24	9	HG-SR152(B) HG-SR1524(B)	145	110	55	50	24	9
HF-SP202(B) HF-SP2024(B)	200	114.3	79	75	35	13.5	HG-SR202(B) HG-SR2024(B)	200	114.3	79	75	35	13.5
HF-SP352(B) HF-SP3524(B)	200	114.3	79	75	35	13.5	HG-SR352(B) HG-SR3524(B)	200	114.3	79	75	35	13.5
HF-SP502(B) HF-SP5024(B)	200	114.3	79	75	35	13.5	HG-SR502(B) HG-SR5024(B)	200	114.3	79	75	35	13.5
HF-SP702(B) HF-SP7024(B)	200	114.3	79	75	35	13.5	HG-SR702(B) HG-SR7024(B)	200	114.3	79	75	35	13.5
HC-RP103(B)	115	95	45	40	24	9	HG-RR103(B)	115	95	45	40	24	9
HC-RP153(B)	115	95	45	40	24	9	HG-RR153(B)	115	95	45	40	24	9
HC-RP203(B)	115	95	45	40	24	9	HG-RR203(B)	115	95	45	40	24	9
HC-RP353(B)	145	110	63	58	28	9	HG-RR353(B)	145	110	63	58	28	9
HC-RP503(B)	145	110	63	58	28	9	HG-RR503(B)	145	110	63	58	28	9

Part 9: Review on Replacement of Motor

(2) HC-LP/HC-UP/HF-JP series

[Unit: mm]

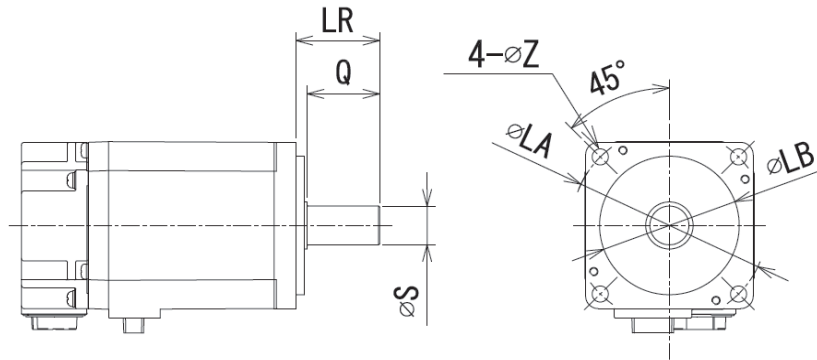

Target models							Replacement models						
Model	LA	LB	LR	Q	S	Z	Example of replacement model (Note)	LA	LB	LR	Q	S	Z
HC-LP52(B)	145	110	55	50	24	9	HG-JR73(B)	100	80	40	30	16	6.6
HC-LP102(B)	145	110	55	50	24	9	HG-JR153(B)	100	80	40	30	16	6.6
HC-LP152(B)	145	110	55	50	24	9	HG-JR353(B)	145	110	55	50	28	9
HC-LP202(B)	200	114.3	79	75	35	13.5	HG-JR353(B)	145	110	55	50	28	9
HC-LP302(B)	200	114.3	79	75	35	13.5	HG-JR503(B)	145	110	55	50	28	9
HC-UP72(B)	200	114.3	55	50	22	13.5	HG-UR72(B)	200	114.3	55	50	22	13.5
HC-UP152(B)	200	114.3	55	50	28	13.5	HG-UR152(B)	200	114.3	55	50	28	13.5
HC-UP202(B)	235	200	65	60	35	13.5	HG-UR202(B)	235	200	65	60	35	13.5
HC-UP352(B)	235	200	65	60	35	13.5	HG-UR352(B)	235	200	65	60	35	13.5
HC-UP502(B)	235	200	65	60	35	13.5	HG-UR502(B)	235	200	65	60	35	13.5
HF-JP53(B) HF-JP534(B)	100	80	40	30	16	6.6	HG-JR53(B) HG-JR534(B)	100	80	40	30	16	6.6
HF-JP73(B) HF-JP734(B)	100	80	40	30	16	6.6	HG-JR73(B) HG-JR734(B)	100	80	40	30	16	6.6
HF-JP103(B) HF-JP1034(B)	100	80	40	30	16	6.6	HG-JR103(B) HG-JR1034(B)	100	80	40	30	16	6.6
HF-JP153(B) HF-JP1534(B)	100	80	40	30	16	6.6	HG-JR153(B) HG-JR1534(B)	100	80	40	30	16	6.6
HF-JP203(B) HF-JP2034(B)	100	80	40	30	16	6.6	HG-JR203(B) HG-JR2034(B)	100	80	40	30	16	6.6
HF-JP353(B) HF-JP3534(B)	145	110	55	50	28	9	HG-JR353(B) HG-JR3534(B)	145	110	55	50	28	9
HF-JP503(B) HF-JP5034(B)	145	110	55	50	28	9	HG-JR503(B) HG-JR5034(B)	145	110	55	50	28	9
HF-JP703(B) HF-JP7034(B)	200	114.3	79	75	35	13.5	HG-JR703(B) HG-JR7034(B)	200	114.3	79	75	35	13.5
HF-JP903(B) HF-JP9034(B)	200	114.3	79	75	35	13.5	HG-JR903(B) HG-JR9034(B)	200	114.3	79	75	35	13.5
HF-JP11K1M(B) HF-JP11K1M4(B)	235	200	116	110	55	13.5	HG-JR11K1M(B) HG-JR11K1M4(B)	235	200	116	110	55	13.5
HF-JP15K1M(B) HF-JP15K1M4(B)	235	200	116	110	55	13.5	HG-JR15K1M(B) HG-JR15K1M4(B)	235	200	116	110	55	13.5

Note. Motor foot cannot be mounted to HG-JR series.

Part 9: Review on Replacement of Motor

(3) HA-LP series

[Unit: mm]

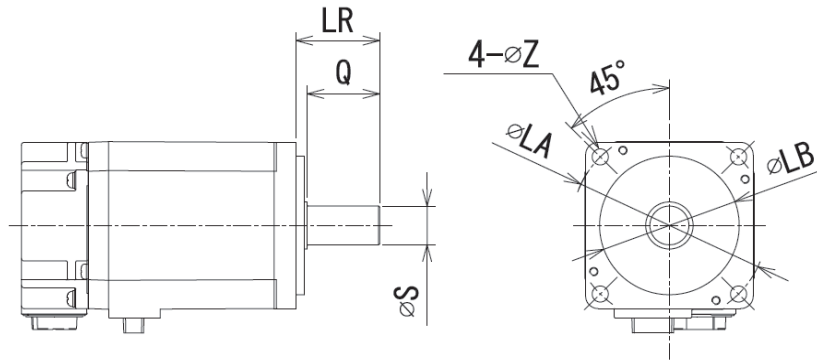

Target models							Replacement models						
Model	LA	LB	LR	Q	S	Z	Example of replacement model (Note)	LA	LB	LR	Q	S	Z
HA-LP601(B) HA-LP6014(B)	215	180	85	80	42	14.5	HG-JR601(B) HG-JR6014(B)	235	200	85	79	42	13.5
HA-LP801(B) HA-LP8014(B)	265	230	110	100	55	14.5	HG-JR801(B) HG-JR8014(B)	235	200	116	110	55	13.5
HA-LP12K1(B) HA-LP12K14(B)	265	230	110	100	55	14.5	HG-JR12K1(B) HG-JR12K14(B)	235	200	116	110	55	13.5
HA-LP15K1 HA-LP15K14	300	250	140	140	60	19	HG-JR15K1 HG-JR15K14	265	230	140	130	65	24
HA-LP20K1 HA-LP20K14	300	250	140	140	60	19	HG-JR20K1 HG-JR20K14	265	230	140	130	65	24
HA-LP25K1 HA-LP25K14	350	300	140	140	65	19	HG-JR25K1 HG-JR25K14	265	230	140	130	65	24
HA-LP30K1 HA-LP30K14	350	300	140	140	65	19	HG-JR30K1 HG-JR30K14	300	250	140	140	80	24
HA-LP37K1 HA-LP37K14	350	300	170	170	80	19	HG-JR37K1 HG-JR37K14	300	250	140	140	80	24
HA-LP701M(B) HA-LP701M4(B)	215	180	85	80	42	14.5	HG-JR701M(B) HG-JR701M4(B)	235	200	85	79	42	13.5
HA-LP11K1M(B) HA-LP11K1M4(B)	265	230	110	100	55	14.5	HG-JR11K1M(B) HG-JR11K1M4(B)	235	200	116	110	55	13.5
HA-LP15K1M(B) HA-LP15K1M4(B)	265	230	110	100	55	14.5	HG-JR15K1M(B) HG-JR15K1M4(B)	235	200	116	110	55	13.5
HA-LP22K1M HA-LP22K1M4	300	250	140	140	60	19	HG-JR22K1M HG-JR22K1M4	265	230	140	130	65	24
HA-LP30K1M HA-LP30K1M4	300	250	140	140	60	19	HG-JR30K1M HG-JR30K1M4	265	230	140	130	65	24
HA-LP37K1M HA-LP37K1M4	350	300	140	140	65	19	HG-JR37K1M HG-JR37K1M4	265	230	140	130	65	24
HA-LP45K1M4	350	300	140	140	65	19	HG-JR45K1M4	300	250	140	140	80	24
HA-LP50K1M4	350	300	170	170	80	19	HG-JR55K1M4	300	250	140	140	80	24
HA-LP502	215	180	85	80	42	14.5	HG-SR502	200	114.3	79	75	35	13.5
HA-LP702	215	180	85	80	42	14.5	HG-SR702	200	114.3	79	75	35	13.5
HA-LP11K2(B) HA-LP11K24(B)	215	180	85	80	42	14.5	HG-JR11K1M(B) HG-JR11K1M4(B)	235	200	116	110	55	13.5
HA-LP15K2(B) HA-LP15K24(B)	265	230	110	100	55	14.5	HG-JR11K1M(B) HG-JR11K1M4(B)	235	200	116	110	55	13.5
HA-LP22K2(B) HA-LP22K24(B)	265	230	110	100	55	14.5	HG-JR15K1M(B) HG-JR15K1M4(B)	235	200	116	110	55	13.5
HA-LP30K2 HA-LP30K24	300	250	140	140	60	19	HG-JR22K1M HG-JR22K1M4	265	230	140	130	65	24
HA-LP37K2 HA-LP37K24	300	250	140	140	60	19	HG-JR30K1M HG-JR30K1M4	265	230	140	130	65	24
HA-LP45K24	350	300	140	140	65	19	HG-JR37K1M4	265	230	140	130	65	24
HA-LP55K24	350	300	140	140	65	19	HG-JR45K1M4	300	250	140	140	80	24

Note. Motor foot cannot be mounted to HG-JR series.

Part 9: Review on Replacement of Motor

2.3 Comparison of Mounting Dimensions for Geared Servo Motors

Servo motor series whose mounting dimensions of the reducer are the same before and after the replacement is omitted.

POINT

- As for the dimensions not listed here, refer to the catalog or Instruction Manual.
- Dimensions with differences are shown with shading.
- The value in the parenthesis shows the value with brake.

Part 9: Review on Replacement of Motor

(1) HC-RP_G5 series (With reduction gear for precision application compliant)

[Unit: mm]

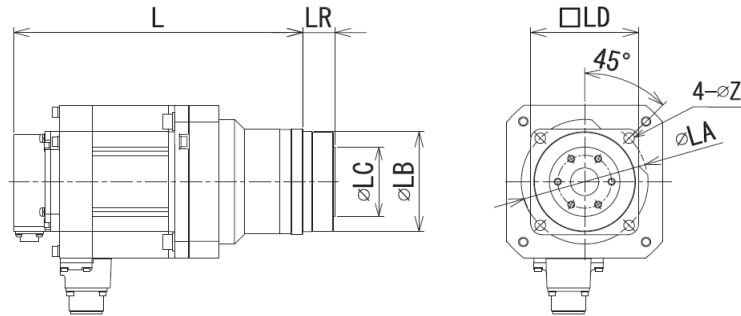

Output (kW)	HC-RP series (G5)								HG-SR series (G5)							
	Reduction ratio	L	LR	LA	LB	LC	LD	Z	Reduction ratio	L	LR	LA	LB	LC	LD	Z
1.0	1/5	227.5 (265.5)	27	105	85	59	90	9	1/5	227.5 (262)	27	105	85	59	90	9
	1/11	227.5 (265.5)	27	105	85	59	90	9	1/11	239.5 (274)	35	135	115	84	120	11
	1/21	255.5 (293.5)	35	135	115	84	120	11	1/21	239.5 (274)	35	135	115	84	120	11
	1/33	255.5 (293.5)	35	135	115	84	120	11	1/33	255.5 (290)	53	190	165	122	170	14
	1/45	268.5 (306.5)	53	190	165	122	170	14	1/45	255.5 (290)	53	190	165	122	170	14
1.5	1/5	252.5 (290)	27	105	85	59	90	9	1/5	241.5 (276)	27	105	85	59	90	9
	1/11	280.5 (318.5)	35	135	115	84	120	11	1/11	253.5 (288)	35	135	115	84	120	11
	1/21	280.5 (318.5)	35	135	115	84	120	11	1/21	269.5 (304)	53	190	165	122	170	14
	1/33	293.5 (331.5)	53	190	165	122	170	14	1/33	269.5 (304)	53	190	165	122	170	14
	1/45	293.5 (331.5)	53	190	165	122	170	14	1/45	269.5 (304)	53	190	165	122	170	14
2.0	1/5	277.5 (315.5)	27	105	85	59	90	9	1/5	267.5 (317)	35	135	115	84	120	11
	1/11	305.5 (343.5)	35	135	115	84	120	11	1/11	267.5 (317)	35	135	115	84	120	11
	1/21	318.5 (365.5)	53	190	165	122	170	14	1/21	287.5 (337)	53	190	165	122	170	14
	1/33	318.5 (365.5)	53	190	165	122	170	14	1/33	287.5 (337)	53	190	165	122	170	14
	1/45	318.5 (365.5)	53	190	165	122	170	14	1/45	287.5 (337)	53	190	165	122	170	14
3.5	1/5	344.5 (381.5)	35	135	115	84	120	11	1/5	291.5 (341)	35	135	115	84	120	11
	1/11	344.5 (381.5)	35	135	115	84	120	11	1/11	311.5 (361)	53	190	165	122	170	14
	1/21	364.5 (401.5)	53	190	165	122	170	14	1/21	311.5 (361)	53	190	165	122	170	14
	1/33	364.5 (401.5)	53	190	165	122	170	14	1/21	311.5 (361)	53	190	165	122	170	14
5.0	1/5	401.5 (438.5)	35	135	115	84	120	11	1/5	327.5 (377)	53	190	165	122	170	14
	1/11	421.5 (458.5)	53	190	165	122	170	14	1/11	327.5 (377)	53	190	165	122	170	14
	1/21	421.5 (458.5)	53	190	165	122	170	14	1/11	327.5 (377)	53	190	165	122	170	14

Part 9: Review on Replacement of Motor

(2) HC-RP_G7 series (With reduction gear for precision application compliant)

[Unit: mm]

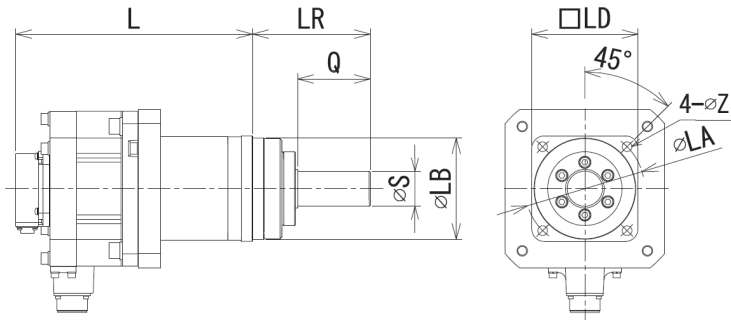

Output (kW)	HC-RP series (G7)									HG-SR series (G7)								
	Reduction ratio	L	LR	Q	S	LA	LB	LD	Z	Reduction ratio	L	LR	Q	S	LA	LB	LD	Z
1.0	1/5	227.5 (265.5)	80	42	25	105	85	90	9	1/5	227.5 (262)	80	42	25	105	85	90	9
	1/11	227.5 (265.5)	80	42	25	105	85	90	9	1/11	239.5 (274)	133	82	40	135	115	120	11
	1/21	255.5 (293.5)	133	82	40	135	115	120	11	1/21	239.5 (274)	133	82	40	135	115	120	11
	1/33	255.5 (293.5)	133	82	40	135	115	120	11	1/33	255.5 (290)	156	82	50	190	165	170	14
	1/45	268.5 (306.5)	156	82	50	190	165	170	14	1/45	255.5 (290)	156	82	50	190	165	170	14
1.5	1/5	252.5 (290.5)	80	42	25	105	85	90	9	1/5	241.5 (276)	80	42	25	105	85	90	9
	1/11	280.5 (318.5)	133	82	40	135	115	120	11	1/11	253.5 (288)	133	82	40	135	115	120	11
	1/21	280.5 (318.5)	133	82	40	135	115	120	11	1/21	269.5 (304)	156	82	50	190	165	170	14
	1/33	293.5 (331.5)	156	82	50	190	165	170	14	1/33	269.5 (304)	156	82	50	190	165	170	14
	1/45	293.5 (331.5)	156	82	50	190	165	170	14	1/45	269.5 (304)	156	82	50	190	165	170	14
2.0	1/5	277.5 (315.5)	80	42	25	105	85	90	9	1/5	267.5 (317)	133	82	40	135	115	120	11
	1/11	305.5 (343.5)	133	82	40	135	115	120	11	1/11	267.5 (317)	133	82	40	135	115	120	11
	1/21	318.5 (356.5)	156	82	50	190	165	170	14	1/21	287.5 (337)	156	82	50	190	165	170	14
	1/33	318.5 (356.5)	156	82	50	190	165	170	14	1/33	287.5 (337)	156	82	50	190	165	170	14
	1/45	318.5 (356.5)	156	82	50	190	165	170	14	1/45	287.5 (337)	156	82	50	190	165	170	14
3.5	1/5	344.5 (381.5)	133	82	40	135	115	120	11	1/5	291.5 (341)	133	82	40	135	115	120	11
	1/11	344.5 (381.5)	133	82	40	135	115	120	11	1/11	311.5 (361)	156	82	50	190	165	170	14
	1/21	364.5 (401.5)	156	82	50	190	165	170	14	1/21	311.5 (361)	156	82	50	190	165	170	14
	1/33	364.5 (401.5)	156	82	50	190	165	170	14	1/33	311.5 (361)	156	82	50	190	165	170	14
5.0	1/5	401.5 (438.5)	133	82	40	135	115	120	11	1/5	327.5 (377)	156	82	50	190	165	170	14
	1/11	421.5 (458.5)	156	82	50	190	165	170	14	1/11	327.5 (377)	156	82	50	190	165	170	14
	1/21	421.5 (458.5)	156	82	50	190	165	170	14	1/21	327.5 (377)	156	82	50	190	165	170	14

Part 9: Review on Replacement of Motor

2.4 Comparison of Actual Reduction Ratios for Geared Servo Motors

POINT
● The HG-MR series does not support the geared model. The geared model is supported with the HG-KR series.
● Actual reduction ratios with differences are shown with shading.

HF-KP_G1/HF-MP_G1(With gears for general industrial machines with a reducer) series

Because the actual reduction ratio for some models is different when replacing HF-KP_G1 or HF-MP_G1 with HG-KR_G1, it is required that an electronic gear be set up.

Output (W)	Reduction ratio	Actual reduction ratio	
		HF-KP/HF-MP series (G1)	HG-KR series (G1)
50	1/5	9/44	9/44
	1/12	49/576	49/576
	1/20	25/484	25/484
100	1/5	9/44	9/44
	1/12	49/576	49/576
	1/20	25/484	25/484
200	1/5	19/96	19/96
	1/12	25/288	961/11664
	1/20	253/5000	513/9984
400	1/5	19/96	19/96
	1/12	25/288	961/11664
	1/20	253/5000	7/135
750	1/5	1/5	1/5
	1/12	525/6048	7/87
	1/20	625/12544	625/12544

Part 9: Review on Replacement of Motor

2.5 Comparison of Moment of Inertia

POINT
● As for the motor specifications not listed here, refer to the catalog or Instruction Manual.
● If the load inertia moment ratio is exceeded, please ask the sales contact.
● The symbols in the table mean as follows. (B): With brake (4): 400 V specifications (H): Foot-mounting
● The value in the parenthesis shows the value with brake.

(1) HF-KP series (With gears for general industrial machines with a reducer)

Series	Target models			Replacement model		
	Model	Moment of inertia J × 10 ⁻⁴ kg·m ²	Load inertia moment ratio	Example of replacement model	Moment of inertia J × 10 ⁻⁴ kg·m ²	Load inertia moment ratio
Small capacity, low inertia HF-KP series	HF-KP053(B)	0.052 (0.054)	15 times or less	HG-KR053(B)	0.0450 (0.0472)	17 times or less
	HF-KP13(B)	0.088 (0.090)		HG-KR13(B)	0.0777 (0.0837)	
	HF-KP23(B)	0.24 (0.31)	24 times or less	HG-KR23(B)	0.221 (0.243)	26 times or less
	HF-KP43(B)	0.42 (0.50)	22 times or less	HG-KR43(B)	0.371 (0.393)	25 times or less
	HF-KP73(B)	1.43 (1.63)	15 times or less	HG-KR73(B)	1.26 (1.37)	17 times or less
Small capacity, low inertia HF-KP series For general industrial machine with a reducer: G1	HF-KP053(B)G1 1/5	0.089 (0.091)	5 times or less	HG-KR053(B)G1 1/5	0.0820 (0.0840)	5 times or less
	HF-KP053(B)G1 1/12	0.111 (0.113)		HG-KR053(B)G1 1/12	0.104 (0.106)	
	HF-KP053(B)G1 1/20	0.093 (0.095)		HG-KR053(B)G1 1/20	0.0860 (0.0880)	
	HF-KP13(B)G1 1/5	0.125 (0.127)		HG-KR13(B)G1 1/5	0.115 (0.121)	
	HF-KP13(B)G1 1/12	0.147 (0.149)		HG-KR13(B)G1 1/12	0.137 (0.143)	
	HF-KP13(B)G1 1/20	0.129 (0.131)	HG-KR13(B)G1 1/20	0.119 (0.125)		
	HF-KP23(B)G1 1/5	0.400 (0.470)	7 times or less	HG-KR23(B)G1 1/5	0.375 (0.397)	7 times or less
	HF-KP23(B)G1 1/12	0.450 (0.520)		HG-KR23(B)G1 1/12	0.418 (0.440)	
	HF-KP23(B)G1 1/20	0.420 (0.490)		HG-KR23(B)G1 1/20	0.391 (0.413)	
	HF-KP43(B)G1 1/5	0.570 (0.650)		HG-KR43(B)G1 1/5	0.525 (0.547)	
	HF-KP43(B)G1 1/12	0.620 (0.700)		HG-KR43(B)G1 1/12	0.568 (0.590)	
	HF-KP43(B)G1 1/20	0.930 (1.01)	HG-KR43(B)G1 1/20	0.881 (0.903)		
	HF-KP73(B)G1 1/5	1.85 (2.05)	5 times or less	HG-KR73(B)G1 1/5	1.68 (1.79)	5 times or less
	HF-KP73(B)G1 1/12	2.52 (2.72)		HG-KR73(B)G1 1/12	2.35 (2.46)	
	HF-KP73(B)G1 1/20	2.58 (2.78)		HG-KR73(B)G1 1/20	2.41 (2.52)	

Part 9: Review on Replacement of Motor

(2) HF-KP series (With reduction gear for precision application compliant)

Series	Target product			Replacement model			
	Model	Moment of inertia J $\times 10^{-4} \text{ kg}\cdot\text{m}^2$	Load inertia moment ratio	Example of replacement model	Moment of inertia J $\times 10^{-4} \text{ kg}\cdot\text{m}^2$	Load inertia moment ratio	
Small capacity, low inertia HF-KP series With flange-output type gear reducer for high precision applications, flange mounting: G5	HF-KP053(B)G5 1/5	0.120 (0.122)	10 times or less	HG-KR053(B)G5 1/5	0.113 (0.115)	10 times or less	
	HF-KP053(B)G5 1/11	0.112 (0.114)		HG-KR053(B)G5 1/11	0.105 (0.107)		
	HF-KP053(B)G5 1/21	0.103 (0.105)		HG-KR053(B)G5 1/21	0.0960 (0.0980)		
	HF-KP053(B)G5 1/33	0.097 (0.099)		HG-KR053(B)G5 1/33	0.0900 (0.0920)		
	HF-KP053(B)G5 1/45	0.097 (0.099)		HG-KR053(B)G5 1/45	0.0900 (0.0920)		
	HF-KP13(B)G5 1/5	0.156 (0.158)		HG-KR13(B)G5 1/5	0.146 (0.152)		
	HF-KP13(B)G5 1/11	0.148 (0.150)		HG-KR13(B)G5 1/11	0.138 (0.144)		
	HF-KP13(B)G5 1/21	0.139 (0.141)		HG-KR13(B)G5 1/21	0.129 (0.135)		
	HF-KP13(B)G5 1/33	0.150 (0.152)		HG-KR13(B)G5 1/33	0.140 (0.146)		
	HF-KP13(B)G5 1/45	0.149 (0.151)		HG-KR13(B)G5 1/45	0.139 (0.145)		
	HF-KP23(B)G5 1/5	0.441 (0.511)	14 times or less	HG-KR23(B)G5 1/5	0.422 (0.444)	14 times or less	
	HF-KP23(B)G5 1/11	0.443 (0.513)		HG-KR23(B)G5 1/11	0.424 (0.446)		
	HF-KP23(B)G5 1/21	0.738 (0.808)		HG-KR23(B)G5 1/21	0.719 (0.741)		
	HF-KP23(B)G5 1/33	0.692 (0.762)		HG-KR23(B)G5 1/33	0.673 (0.695)		
	HF-KP23(B)G5 1/45	0.691 (0.761)		HG-KR23(B)G5 1/45	0.672 (0.694)		
	HF-KP43(B)G5 1/5	0.621 (0.701)		HG-KR43(B)G5 1/5	0.572 (0.594)		
	HF-KP43(B)G5 1/11	0.996 (1.08)		HG-KR43(B)G5 1/11	0.947 (0.969)		
	HF-KP43(B)G5 1/21	0.918 (0.998)		HG-KR43(B)G5 1/21	0.869 (0.891)		
	HF-KP43(B)G5 1/33	0.970 (1.05)		HG-KR43(B)G5 1/33	0.921 (0.943)		
	HF-KP43(B)G5 1/45	0.964 (1.04)		HG-KR43(B)G5 1/45	0.915 (0.937)		
	HF-KP73(B)G5 1/5	2.08 (2.28)	10 times or less	HG-KR73(B)G5 1/5	1.91 (2.02)	10 times or less	
	HF-KP73(B)G5 1/11	1.99 (2.19)		HG-KR73(B)G5 1/11	1.82 (1.93)		
	HF-KP73(B)G5 1/21	2.18 (2.38)		HG-KR73(B)G5 1/21	2.01 (2.12)		
	HF-KP73(B)G5 1/33	1.96 (2.16)		HG-KR73(B)G5 1/33	1.79 (1.90)		
	HF-KP73(B)G5 1/45	1.96 (2.16)		HG-KR73(B)G5 1/45	1.79 (1.90)		
	Small capacity, low inertia HF-KP series With shaft-output type gear reducer for high precision applications, flange mounting :G7	HF-KP053(B)G7 1/5	0.126 (0.128)	10 times or less	HG-KR053(B)G7 1/5	0.119 (0.121)	10 times or less
		HF-KP053(B)G7 1/11	0.113 (0.115)		HG-KR053(B)G7 1/11	0.106 (0.108)	
		HF-KP053(B)G7 1/21	0.103 (0.105)		HG-KR053(B)G7 1/21	0.0960 (0.0980)	
HF-KP053(B)G7 1/33		0.097 (0.099)	HG-KR053(B)G7 1/33		0.0900 (0.0920)		
HF-KP053(B)G7 1/45		0.097 (0.099)	HG-KR053(B)G7 1/45		0.0900 (0.0920)		
HF-KP13(B)G7 1/5		0.162 (0.164)	HG-KR13(B)G7 1/5		0.152 (0.158)		
HF-KP13(B)G7 1/11		0.149 (0.151)	HG-KR13(B)G7 1/11		0.139 (0.145)		
HF-KP13(B)G7 1/21		0.139 (0.141)	HG-KR13(B)G7 1/21		0.129 (0.135)		
HF-KP13(B)G7 1/33		0.151 (0.153)	HG-KR13(B)G7 1/33		0.141 (0.147)		
HF-KP13(B)G7 1/45		0.149 (0.151)	HG-KR13(B)G7 1/45		0.139 (0.145)		
HF-KP23(B)G7 1/5		0.447 (0.517)	14 times or less	HG-KR23(B)G7 1/5	0.428 (0.450)	14 times or less	
HF-KP23(B)G7 1/11		0.443 (0.513)		HG-KR23(B)G7 1/11	0.424 (0.446)		
HF-KP23(B)G7 1/21		0.740 (0.810)		HG-KR23(B)G7 1/21	0.721 (0.743)		
HF-KP23(B)G7 1/33		0.693 (0.763)		HG-KR23(B)G7 1/33	0.674 (0.696)		
HF-KP23(B)G7 1/45		0.691 (0.761)		HG-KR23(B)G7 1/45	0.672 (0.694)		
HF-KP43(B)G7 1/5		0.627 (0.707)		HG-KR43(B)G7 1/5	0.578 (0.600)		
HF-KP43(B)G7 1/11		1.00 (1.08)		HG-KR43(B)G7 1/11	0.955 (0.977)		
HF-KP43(B)G7 1/21		0.920 (1.00)		HG-KR43(B)G7 1/21	0.871 (0.893)		
HF-KP43(B)G7 1/33		0.976 (1.06)		HG-KR43(B)G7 1/33	0.927 (0.949)		
HF-KP43(B)G7 1/45		0.967 (1.05)		HG-KR43(B)G7 1/45	0.918 (0.940)		
HF-KP73(B)G7 1/5		2.12 (2.32)	10 times or less	HG-KR73(B)G7 1/5	1.95 (2.06)	10 times or less	
HF-KP73(B)G7 1/11		2.00 (2.20)		HG-KR73(B)G7 1/11	1.83 (1.94)		
HF-KP73(B)G7 1/21		2.20 (2.40)		HG-KR73(B)G7 1/21	2.03 (2.14)		
HF-KP73(B)G7 1/33		1.97 (2.17)		HG-KR73(B)G7 1/33	1.80 (1.91)		
HF-KP73(B)G7 1/45		1.96 (2.16)		HG-KR73(B)G7 1/45	1.79 (1.90)		

Part 9: Review on Replacement of Motor

(3) HF-MP series (With gears for general industrial machines)

Series	Target models			Replacement models		
	Model	Moment of inertia J $\times 10^{-4} \text{ kg}\cdot\text{m}^2$	Load inertia moment ratio	Example of replacement model	Moment of inertia J $\times 10^{-4} \text{ kg}\cdot\text{m}^2$	Load inertia moment ratio
Small capacity, ultra-low inertia HF-MP series	HF-MP053(B)	0.019 (0.025)	30 times or less	HG-MR053(B)	0.0162 (0.0224)	35 times or less
	HF-MP13(B)	0.032 (0.039)		HG-MR13(B)	0.0300 (0.0362)	32 times or less
	HF-MP23(B)	0.088 (0.12)		HG-MR23(B)	0.0865 (0.109)	
	HF-MP43(B)	0.15 (0.18)		HG-MR43(B)	0.142 (0.164)	
	HF-MP73(B)	0.60 (0.70)		HG-MR73(B)	0.586 (0.694)	
Small capacity, ultra-low inertia HF-MP series With gears for general industrial machines: G1	HF-MP053(B)G1 1/5	0.056 (0.062)	25 times or less	HG-KR053(B)G1 1/5	0.0820 (0.0840)	5 times or less
	HF-MP053(B)G1 1/12	0.078 (0.084)		HG-KR053(B)G1 1/12	0.104 (0.106)	
	HF-MP053(B)G1 1/20	0.060 (0.066)		HG-KR053(B)G1 1/20	0.0860 (0.0880)	
	HF-MP13(B)G1 1/5	0.069 (0.076)		HG-KR13(B)G1 1/5	0.115 (0.121)	
	HF-MP13(B)G1 1/12	0.091 (0.089)		HG-KR13(B)G1 1/12	0.137 (0.143)	
	HF-MP13(B)G1 1/20	0.073 (0.080)		HG-KR13(B)G1 1/20	0.119 (0.125)	7 times or less
	HF-MP23(B)G1 1/5	0.248 (0.280)		HG-KR23(B)G1 1/5	0.375 (0.397)	
	HF-MP23(B)G1 1/12	0.298 (0.330)		HG-KR23(B)G1 1/12	0.418 (0.440)	
	HF-MP23(B)G1 1/20	0.268 (0.300)		HG-KR23(B)G1 1/20	0.391 (0.413)	
	HF-MP43(B)G1 1/5	0.300 (0.330)		HG-KR43(B)G1 1/5	0.525 (0.547)	
	HF-MP43(B)G1 1/12	0.350 (0.380)		HG-KR43(B)G1 1/12	0.568 (0.590)	5 times or less
	HF-MP43(B)G1 1/20	0.660 (0.690)		HG-KR43(B)G1 1/20	0.881 (0.903)	
	HF-MP73(B)G1 1/5	1.02 (1.12)		HG-KR73(B)G1 1/5	1.68 (1.79)	
	HF-MP73(B)G1 1/12	1.69 (1.79)		HG-KR73(B)G1 1/12	2.35 (2.46)	
	HF-MP73(B)G1 1/20	1.75 (1.85)		HG-KR73(B)G1 1/20	2.41 (2.52)	

Part 9: Review on Replacement of Motor

(4) HF-MP series (With reduction gear for precision application compliant)

Series	Target models			Replacement models		
	Model	Moment of inertia J $\times 10^{-4} \text{ kg}\cdot\text{m}^2$	Load inertia moment ratio	Example of replacement model	Moment of inertia J $\times 10^{-4} \text{ kg}\cdot\text{m}^2$	Load inertia moment ratio
Small capacity, ultra-low inertia HF-MP series With flange-output type gear reducer for high precision applications, flange mounting: G5	HF-MP053(B)G5 1/5	0.087 (0.093)	25 times or less	HG-KR053(B)G5 1/5	0.113 (0.115)	10 times or less
	HF-MP053(B)G5 1/11	0.079 (0.085)		HG-KR053(B)G5 1/11	0.105 (0.107)	
	HF-MP053(B)G5 1/21	0.070 (0.076)		HG-KR053(B)G5 1/21	0.0960 (0.0980)	
	HF-MP053(B)G5 1/33	0.064 (0.070)		HG-KR053(B)G5 1/33	0.0900 (0.0920)	
	HF-MP053(B)G5 1/45	0.064 (0.070)		HG-KR053(B)G5 1/45	0.0900 (0.0920)	
	HF-MP13(B)G5 1/5	0.100 (0.107)		HG-KR13(B)G5 1/5	0.146 (0.152)	
	HF-MP13(B)G5 1/11	0.092 (0.099)		HG-KR13(B)G5 1/11	0.138 (0.144)	
	HF-MP13(B)G5 1/21	0.083 (0.090)		HG-KR13(B)G5 1/21	0.129 (0.135)	
	HF-MP13(B)G5 1/33	0.094 (0.101)		HG-KR13(B)G5 1/33	0.140 (0.146)	
	HF-MP13(B)G5 1/45	0.093 (0.100)		HG-KR13(B)G5 1/45	0.139 (0.145)	
	HF-MP23(B)G5 1/5	0.289 (0.321)		HG-KR23(B)G5 1/5	0.422 (0.444)	14 times or less
	HF-MP23(B)G5 1/11	0.291 (0.323)		HG-KR23(B)G5 1/11	0.424 (0.446)	
	HF-MP23(B)G5 1/21	0.586 (0.618)		HG-KR23(B)G5 1/21	0.719 (0.741)	
	HF-MP23(B)G5 1/33	0.540 (0.572)		HG-KR23(B)G5 1/33	0.673 (0.695)	
	HF-MP23(B)G5 1/45	0.539 (0.571)		HG-KR23(B)G5 1/45	0.672 (0.694)	
	HF-MP43(B)G5 1/5	0.351 (0.381)		HG-KR43(B)G5 1/5	0.572 (0.594)	
	HF-MP43(B)G5 1/11	0.726 (0.756)		HG-KR43(B)G5 1/11	0.947 (0.969)	
	HF-MP43(B)G5 1/21	0.648 (0.678)		HG-KR43(B)G5 1/21	0.869 (0.891)	
	HF-MP43(B)G5 1/33	0.700 (0.730)		HG-KR43(B)G5 1/33	0.921 (0.943)	
	HF-MP43(B)G5 1/45	0.694 (0.724)		HG-KR43(B)G5 1/45	0.915 (0.937)	
	HF-MP73(B)G5 1/5	1.25 (1.35)		HG-KR73(B)G5 1/5	1.91 (2.02)	10 times or less
	HF-MP73(B)G5 1/11	1.16 (1.26)		HG-KR73(B)G5 1/11	1.82 (1.93)	
	HF-MP73(B)G5 1/21	1.35 (1.45)		HG-KR73(B)G5 1/21	2.01 (2.12)	
	HF-MP73(B)G5 1/33	1.13 (1.23)		HG-KR73(B)G5 1/33	1.79 (1.90)	
HF-MP73(B)G5 1/45	1.13 (1.23)	HG-KR73(B)G5 1/45	1.79 (1.90)			
Small capacity, ultra-low inertia HF-MP series With shaft-output type gear reducer for high precision applications, flange mounting: G7	HF-MP053(B)G7 1/5	0.093 (0.099)	25 times or less	HG-KR053(B)G7 1/5	0.119 (0.121)	10 times or less
	HF-MP053(B)G7 1/11	0.080 (0.086)		HG-KR053(B)G7 1/11	0.106 (0.108)	
	HF-MP053(B)G7 1/21	0.070 (0.076)		HG-KR053(B)G7 1/21	0.0960 (0.0980)	
	HF-MP053(B)G7 1/33	0.064 (0.070)		HG-KR053(B)G7 1/33	0.0900 (0.0920)	
	HF-MP053(B)G7 1/45	0.064 (0.070)		HG-KR053(B)G7 1/45	0.0900 (0.0920)	
	HF-MP13(B)G7 1/5	0.106 (0.113)		HG-KR13(B)G7 1/5	0.152 (0.158)	
	HF-MP13(B)G7 1/11	0.093 (0.100)		HG-KR13(B)G7 1/11	0.139 (0.145)	
	HF-MP13(B)G7 1/21	0.083 (0.090)		HG-KR13(B)G7 1/21	0.129 (0.135)	
	HF-MP13(B)G7 1/33	0.095 (0.102)		HG-KR13(B)G7 1/33	0.141 (0.147)	
	HF-MP13(B)G7 1/45	0.093 (0.100)		HG-KR13(B)G7 1/45	0.139 (0.145)	
	HF-MP23(B)G7 1/5	0.295 (0.327)		HG-KR23(B)G7 1/5	0.428 (0.450)	14 times or less
	HF-MP23(B)G7 1/11	0.291 (0.323)		HG-KR23(B)G7 1/11	0.424 (0.446)	
	HF-MP23(B)G7 1/21	0.588 (0.620)		HG-KR23(B)G7 1/21	0.721 (0.743)	
	HF-MP23(B)G7 1/33	0.541 (0.573)		HG-KR23(B)G7 1/33	0.674 (0.696)	
	HF-MP23(B)G7 1/45	0.539 (0.571)		HG-KR23(B)G7 1/45	0.672 (0.694)	
	HF-MP43(B)G7 1/5	0.357 (0.387)		HG-KR43(B)G7 1/5	0.578 (0.600)	
	HF-MP43(B)G7 1/11	0.734 (0.764)		HG-KR43(B)G7 1/11	0.955 (0.977)	
	HF-MP43(B)G7 1/21	0.650 (0.680)		HG-KR43(B)G7 1/21	0.871 (0.893)	
	HF-MP43(B)G7 1/33	0.706 (0.736)		HG-KR43(B)G7 1/33	0.927 (0.949)	
	HF-MP43(B)G7 1/45	0.697 (0.727)		HG-KR43(B)G7 1/45	0.918 (0.940)	
	HF-MP73(B)G7 1/5	1.29 (1.39)		HG-KR73(B)G7 1/5	1.95 (2.06)	10 times or less
	HF-MP73(B)G7 1/11	1.17 (1.27)		HG-KR73(B)G7 1/11	1.83 (1.94)	
	HF-MP73(B)G7 1/21	1.37 (1.47)		HG-KR73(B)G7 1/21	2.03 (2.14)	
	HF-MP73(B)G7 1/33	1.14 (1.24)		HG-KR73(B)G7 1/33	1.80 (1.91)	
HF-MP73(B)G7 1/45	1.13 (1.23)	HG-KR73(B)G7 1/45	1.79 (1.90)			

Part 9: Review on Replacement of Motor

(5) HF-SP series

Series	Target models			Replacement models		
	Model	Moment of inertia J $\times 10^{-4} \text{ kg}\cdot\text{m}^2$	Load inertia moment ratio	Example of replacement model	Moment of inertia J $\times 10^{-4} \text{ kg}\cdot\text{m}^2$	Load inertia moment ratio
Medium capacity, medium inertia HF-SP series	HF-SP51(B)	11.9 (14.0)	15 times or less	HG-SR51(B)	11.6 (13.8)	17 times or less
	HF-SP81(B)	17.8 (20.0)		HG-SR81(B)	16.0 (18.2)	
	HF-SP121(B)	38.3 (47.9)		HG-SR121(B)	46.8 (56.5)	15 times or less
	HF-SP201(B)	75.0 (84.7)		HG-SR201(B)	78.6 (88.2)	
	HF-SP301(B)	97.0 (107)		HG-SR301(B)	99.7 (109)	
	HF-SP421(B)	154 (164)		HG-SR421(B)	151 (161)	
	HF-SP52(B)	6.1 (8.3)		HG-SR52(B)	7.26 (9.48)	17 times or less
	HF-SP524(B)			HG-SR524(B)		
	HF-SP102(B)	11.9 (14.0)		HG-SR102(B)	11.6 (13.8)	17 times or less
	HF-SP1024(B)			HG-SR1024(B)		
	HF-SP152(B)	17.8 (20.0)		HG-SR152(B)	16.0 (18.2)	15 times or less
	HF-SP1524(B)			HG-SR1524(B)		
	HF-SP202(B)	38.3 (47.9)		HG-SR202(B)	46.8 (56.5)	15 times or less
	HF-SP2024(B)			HG-SR2024(B)		
	HF-SP352(B)	75.0 (84.7)		HG-SR352(B)	78.6 (88.2)	
	HF-SP3524(B)			HG-SR3524(B)		
	HF-SP502(B)	97.0 (107)		HG-SR502(B)	99.7 (109)	15 times or less
	HF-SP5024(B)			HG-SR5024(B)		
HF-SP702(B)	154 (164)	HG-SR702(B)	151 (161)	15 times or less		
HF-SP7024(B)		HG-SR7024(B)				

Part 9: Review on Replacement of Motor

(6) HF-SP series (For general industrial machine with a reducer)

Series	Target models			Replacement models		
	Model	Moment of inertia J $\times 10^{-4} \text{ kg}\cdot\text{m}^2$	Load inertia moment ratio	Example of replacement model	Moment of inertia J $\times 10^{-4} \text{ kg}\cdot\text{m}^2$	Load inertia moment ratio
Medium capacity, medium inertia HF-SP series With gears for general industrial machines: G1	HF-SP52(4)(B)G1(H) 1/6	7.10 (9.30)	4 times or less	HG-SR52(4)(B)G1(H) 1/6	8.08 (10.3)	4 times or less
	HF-SP52(4)(B)G1(H) 1/11	6.70 (8.80)		HG-SR52(4)(B)G1(H) 1/11	7.65 (9.85)	
	HF-SP52(4)(B)G1(H) 1/17	6.60 (8.70)		HG-SR52(4)(B)G1(H) 1/17	7.53 (9.73)	
	HF-SP52(4)(B)G1(H) 1/29	6.50 (8.70)		HG-SR52(4)(B)G1(H) 1/29	7.47 (9.67)	
	HF-SP52(4)(B)G1(H) 1/35	7.30 (9.40)		HG-SR52(4)(B)G1(H) 1/35	8.26 (10.5)	
	HF-SP52(4)(B)G1(H) 1/43	7.30 (9.40)		HG-SR52(4)(B)G1(H) 1/43	8.22 (10.4)	
	HF-SP52(4)(B)G1(H) 1/59	7.20 (9.40)		HG-SR52(4)(B)G1(H) 1/59	8.18 (10.4)	
	HF-SP102(4)(B)G1(H) 1/6	15.4 (17.5)		HG-SR102(4)(B)G1(H) 1/6	14.8 (17.0)	
	HF-SP102(4)(B)G1(H) 1/11	13.9 (16.0)		HG-SR102(4)(B)G1(H) 1/11	13.3 (15.5)	
	HF-SP102(4)(B)G1(H) 1/17	13.5 (15.6)		HG-SR102(4)(B)G1(H) 1/17	12.9 (15.1)	
	HF-SP102(4)(B)G1(H) 1/29	13.2 (15.3)		HG-SR102(4)(B)G1(H) 1/29	12.6 (14.8)	
	HF-SP102(4)(B)G1(H) 1/35	13.2 (15.3)		HG-SR102(4)(B)G1(H) 1/35	12.6 (14.8)	
	HF-SP102(4)(B)G1(H) 1/43	14.3 (16.5)		HG-SR102(4)(B)G1(H) 1/43	13.8 (16.0)	
	HF-SP102(4)(B)G1(H) 1/59	20.3 (22.4)		HG-SR102(4)(B)G1(H) 1/59	19.1 (21.3)	
	HF-SP152(4)(B)G1(H) 1/6	21.3 (23.4)		HG-SR152(4)(B)G1(H) 1/6	19.2 (21.4)	
	HF-SP152(4)(B)G1(H) 1/11	19.8 (21.9)		HG-SR152(4)(B)G1(H) 1/11	17.7 (19.9)	
	HF-SP152(4)(B)G1(H) 1/17	19.4 (21.6)		HG-SR152(4)(B)G1(H) 1/17	17.3 (19.5)	
	HF-SP152(4)(B)G1(H) 1/29	20.4 (22.6)		HG-SR152(4)(B)G1(H) 1/29	18.4 (20.6)	
	HF-SP152(4)(B)G1(H) 1/35	20.4 (22.5)		HG-SR152(4)(B)G1(H) 1/35	18.3 (20.5)	
	HF-SP152(4)(B)G1(H) 1/43	26.3 (28.4)		HG-SR152(4)(B)G1(H) 1/43	23.6 (25.8)	
	HF-SP152(4)(B)G1(H) 1/59	26.2 (28.3)		HG-SR152(4)(B)G1(H) 1/59	23.5 (25.7)	
	HF-SP202(4)(B)G1(H) 1/6	42.1 (51.7)		HG-SR202(4)(B)G1(H) 1/6	50.0 (59.4)	
	HF-SP202(4)(B)G1(H) 1/11	40.5 (50.2)		HG-SR202(4)(B)G1(H) 1/11	48.4 (57.8)	
	HF-SP202(4)(B)G1(H) 1/17	40.2 (49.8)		HG-SR202(4)(B)G1(H) 1/17	48.1 (57.5)	
	HF-SP202(4)(B)G1(H) 1/29	46.9 (56.6)		HG-SR202(4)(B)G1(H) 1/29	54.8 (64.2)	
	HF-SP202(4)(B)G1(H) 1/35	46.7 (56.4)		HG-SR202(4)(B)G1(H) 1/35	54.5 (63.9)	
	HF-SP202(4)(B)G1(H) 1/43	46.4 (56.1)		HG-SR202(4)(B)G1(H) 1/43	54.3 (63.7)	
	HF-SP202(4)(B)G1(H) 1/59	46.4 (56.0)		HG-SR202(4)(B)G1(H) 1/59	54.2 (63.6)	
	HF-SP352(4)(B)G1(H) 1/6	84.4 (94.0)		HG-SR352(4)(B)G1(H) 1/6	87.1 (96.5)	
	HF-SP352(4)(B)G1(H) 1/11	80.1 (89.8)		HG-SR352(4)(B)G1(H) 1/11	82.8 (92.2)	
	HF-SP352(4)(B)G1(H) 1/17	78.8 (88.5)		HG-SR352(4)(B)G1(H) 1/17	81.5 (90.9)	
	HF-SP352(4)(B)G1(H) 1/29	83.9 (93.6)		HG-SR352(4)(B)G1(H) 1/29	86.6 (96.0)	
	HF-SP352(4)(B)G1(H) 1/35	83.7 (93.3)		HG-SR352(4)(B)G1(H) 1/35	86.3 (95.7)	
	HF-SP352(4)(B)G1(H) 1/43	101.9 (111.5)		HG-SR352(4)(B)G1(H) 1/43	105 (114)	
	HF-SP352(4)(B)G1(H) 1/59	101.3 (110.9)		HG-SR352(4)(B)G1(H) 1/59	104 (113)	
	HF-SP502(4)(B)G1(H) 1/6	121.2 (130.8)		HG-SR502(4)(B)G1(H) 1/6	126 (135)	
	HF-SP502(4)(B)G1(H) 1/11	108.9 (118.5)		HG-SR502(4)(B)G1(H) 1/11	114 (123)	
	HF-SP502(4)(B)G1(H) 1/17	104.8 (114.5)		HG-SR502(4)(B)G1(H) 1/17	110 (119)	
	HF-SP502(4)(B)G1(H) 1/29	135.6 (145.3)		HG-SR502(4)(B)G1(H) 1/29	141 (150)	
	HF-SP502(4)(B)G1(H) 1/35	135.1 (144.8)		HG-SR502(4)(B)G1(H) 1/35	140 (150)	
	HF-SP502(4)(B)G1(H) 1/43	134.1 (143.8)		HG-SR502(4)(B)G1(H) 1/43	139 (149)	
	HF-SP502(4)(B)G1(H) 1/59	132.9 (142.6)		HG-SR502(4)(B)G1(H) 1/59	138 (147)	
	HF-SP702(4)(B)G1(H) 1/6	177.4 (187.0)		HG-SR702(4)(B)G1(H) 1/6	177 (187)	
	HF-SP702(4)(B)G1(H) 1/11	190.2 (199.9)		HG-SR702(4)(B)G1(H) 1/11	190 (199)	
	HF-SP702(4)(B)G1(H) 1/17	182.7 (192.4)		HG-SR702(4)(B)G1(H) 1/17	182 (192)	
	HF-SP702(4)(B)G1(H) 1/29	192.3 (202.0)		HG-SR702(4)(B)G1(H) 1/29	192 (202)	
	HF-SP702(4)(B)G1(H) 1/35	191.8 (201.5)		HG-SR702(4)(B)G1(H) 1/35	192 (201)	
	HF-SP702(4)(B)G1(H) 1/43	269.8 (278.3)		HG-SR702(4)(B)G1(H) 1/43	267 (277)	
HF-SP702(4)(B)G1(H) 1/59	268.0 (276.5)	HG-SR702(4)(B)G1(H) 1/59	266 (275)			

Part 9: Review on Replacement of Motor

(7) HF-SP series (With reduction gear for precision application compliant)

Series	Target models			Replacement models		
	Model	Moment of inertia J × 10 ⁻⁴ kg·m ²	Load inertia moment ratio	Example of replacement model	Moment of inertia J × 10 ⁻⁴ kg·m ²	Load inertia moment ratio
Medium capacity, medium inertia HF-SP series With flange-output type gear reducer for high precision applications, flange mounting: G5	HF-SP52(4)(B)G5 1/5	6.75 (8.95)	10 times or less	HG-SR52(4)(B)G5 1/5	7.91 (10.1)	10 times or less
	HF-SP52(4)(B)G5 1/11	6.66 (8.86)		HG-SR52(4)(B)G5 1/11	7.82 (10.0)	
	HF-SP52(4)(B)G5 1/21	9.00 (11.2)		HG-SR52(4)(B)G5 1/21	10.2 (12.4)	
	HF-SP52(4)(B)G5 1/33	8.80 (11.0)		HG-SR52(4)(B)G5 1/33	9.96 (12.2)	
	HF-SP52(4)(B)G5 1/45	8.80 (11.0)		HG-SR52(4)(B)G5 1/45	9.96 (12.2)	
	HF-SP102(4)(B)G5 1/5	12.6 (14.7)		HG-SR102(4)(B)G5 1/5	12.3 (14.5)	
	HF-SP102(4)(B)G5 1/11	15.2 (17.3)		HG-SR102(4)(B)G5 1/11	14.9 (17.1)	
	HF-SP102(4)(B)G5 1/21	14.8 (16.9)		HG-SR102(4)(B)G5 1/21	14.5 (16.7)	
	HF-SP102(4)(B)G5 1/33	16.6 (18.7)		HG-SR102(4)(B)G5 1/33	16.3 (18.5)	
	HF-SP102(4)(B)G5 1/45	16.5 (18.6)		HG-SR102(4)(B)G5 1/45	16.2 (18.4)	
	HF-SP152(4)(B)G5 1/5	18.5 (20.7)		HG-SR152(4)(B)G5 1/5	16.7 (18.9)	
	HF-SP152(4)(B)G5 1/11	21.1 (23.3)		HG-SR152(4)(B)G5 1/11	19.3 (21.5)	
	HF-SP152(4)(B)G5 1/21	23.5 (25.7)		HG-SR152(4)(B)G5 1/21	21.7 (23.9)	
	HF-SP152(4)(B)G5 1/33	22.5 (24.7)		HG-SR152(4)(B)G5 1/33	20.7 (22.9)	
	HF-SP152(4)(B)G5 1/45	22.4 (24.6)		HG-SR152(4)(B)G5 1/45	20.6 (22.8)	
	HF-SP202(4)(B)G5 1/5	42.9 (52.5)		HG-SR202(4)(B)G5 1/5	51.4 (61.1)	
	HF-SP202(4)(B)G5 1/11	42.7 (52.3)		HG-SR202(4)(B)G5 1/11	51.2 (60.9)	
	HF-SP202(4)(B)G5 1/21	44.7 (54.3)		HG-SR202(4)(B)G5 1/21	53.2 (62.9)	
	HF-SP202(4)(B)G5 1/33	43.7 (53.3)		HG-SR202(4)(B)G5 1/33	52.2 (61.9)	
	HF-SP202(4)(B)G5 1/45	43.7 (53.3)		HG-SR202(4)(B)G5 1/45	52.2 (61.9)	
	HF-SP352(4)(B)G5 1/5	79.6 (89.3)		HG-SR352(4)(B)G5 1/5	83.2 (92.8)	
	HF-SP352(4)(B)G5 1/11	83.1 (92.8)		HG-SR352(4)(B)G5 1/11	86.7 (96.3)	
	HF-SP352(4)(B)G5 1/21	81.4 (91.1)		HG-SR352(4)(B)G5 1/21	85.0 (94.6)	
	HF-SP502(4)(B)G5 1/5	107.1 (117.1)		HG-SR502(4)(B)G5 1/5	110 (119)	
HF-SP502(4)(B)G5 1/11	105.1 (115.1)	HG-SR502(4)(B)G5 1/11	108 (117)			
HF-SP702(4)(B)G5 1/5	164.1 (174.1)	HG-SR702(4)(B)G5 1/5	161 (171)			
Medium capacity, medium inertia HF-SP series With shaft-output type gear reducer for high precision applications, flange mounting: G7	HF-SP52(4)(B)G7 1/5	6.79 (8.99)	10 times or less	HG-SR52(4)(B)G7 1/5	7.95 (10.2)	10 times or less
	HF-SP52(4)(B)G7 1/11	6.66 (8.86)		HG-SR52(4)(B)G7 1/11	7.82 (10.0)	
	HF-SP52(4)(B)G7 1/21	9.00 (11.2)		HG-SR52(4)(B)G7 1/21	10.2 (12.4)	
	HF-SP52(4)(B)G7 1/33	8.80 (11.0)		HG-SR52(4)(B)G7 1/33	9.96 (12.2)	
	HF-SP52(4)(B)G7 1/45	8.80 (11.0)		HG-SR52(4)(B)G7 1/45	9.96 (12.2)	
	HF-SP102(4)(B)G7 1/5	12.6 (14.7)		HG-SR102(4)(B)G7 1/5	12.3 (14.5)	
	HF-SP102(4)(B)G7 1/11	15.3 (17.4)		HG-SR102(4)(B)G7 1/11	15.0 (17.2)	
	HF-SP102(4)(B)G7 1/21	14.8 (16.9)		HG-SR102(4)(B)G7 1/21	14.5 (16.7)	
	HF-SP102(4)(B)G7 1/33	16.6 (18.7)		HG-SR102(4)(B)G7 1/33	16.3 (18.5)	
	HF-SP102(4)(B)G7 1/45	16.6 (18.7)		HG-SR102(4)(B)G7 1/45	16.3 (18.5)	
	HF-SP152(4)(B)G7 1/5	18.5 (20.7)		HG-SR152(4)(B)G7 1/5	16.7 (18.9)	
	HF-SP152(4)(B)G7 1/11	21.2 (23.4)		HG-SR152(4)(B)G7 1/11	19.4 (21.6)	
	HF-SP152(4)(B)G7 1/21	23.5 (25.7)		HG-SR152(4)(B)G7 1/21	21.7 (23.9)	
	HF-SP152(4)(B)G7 1/33	22.5 (24.7)		HG-SR152(4)(B)G7 1/33	20.7 (22.9)	
	HF-SP152(4)(B)G7 1/45	22.5 (24.7)		HG-SR152(4)(B)G7 1/45	20.7 (22.9)	
	HF-SP202(4)(B)G7 1/5	43.2 (52.8)		HG-SR202(4)(B)G7 1/5	51.7 (61.4)	
	HF-SP202(4)(B)G7 1/11	42.8 (52.4)		HG-SR202(4)(B)G7 1/11	51.3 (61.0)	
	HF-SP202(4)(B)G7 1/21	44.8 (54.4)		HG-SR202(4)(B)G7 1/21	53.3 (63.0)	
	HF-SP202(4)(B)G7 1/33	43.7 (53.3)		HG-SR202(4)(B)G7 1/33	52.2 (61.9)	
	HF-SP202(4)(B)G7 1/45	43.7 (53.3)		HG-SR202(4)(B)G7 1/45	52.2 (61.9)	
	HF-SP352(4)(B)G7 1/5	79.9 (89.6)		HG-SR352(4)(B)G7 1/5	83.5 (93.1)	
	HF-SP352(4)(B)G7 1/11	83.4 (93.1)		HG-SR352(4)(B)G7 1/11	87.0 (96.6)	
	HF-SP352(4)(B)G7 1/21	81.5 (91.2)		HG-SR352(4)(B)G7 1/21	85.1 (94.7)	
	HF-SP502(4)(B)G7 1/5	108.5 (118.5)		HG-SR502(4)(B)G7 1/5	111 (121)	
HF-SP502(4)(B)G7 1/11	105.4 (115.4)	HG-SR502(4)(B)G7 1/11	108 (117)			
HF-SP702(4)(B)G7 1/5	165.5 (175.5)	HG-SR702(4)(B)G7 1/5	163 (173)			

Part 9: Review on Replacement of Motor

(8) HC-RP series

Series	Target models			Replacement models		
	Model	Moment of inertia J × 10 ⁻⁴ kg·m ²	Load inertia moment ratio	Example of replacement model	Moment of inertia J × 10 ⁻⁴ kg·m ²	Load inertia moment ratio
Medium capacity, ultra-low inertia HC-RP series	HC-RP103(B)	1.50 (1.85)	5 times or less	HG-RR103(B)	1.50 (1.85)	5 times or less
	HC-RP153(B)	1.90 (2.25)		HG-RR153(B)	1.90 (2.25)	
	HC-RP203(B)	2.30 (2.65)		HG-RR203(B)	2.30 (2.65)	
	HC-RP353(B)	8.30 (11.8)		HG-RR353(B)	8.30 (11.8)	
	HC-RP503(B)	12.0 (15.5)		HG-RR503(B)	12.0 (15.5)	
Medium capacity, ultra-low inertia HC-RP series With flange-output type gear reducer for high precision applications, flange mounting:G5	HC-RP103(B)G5 1/5	2.33 (2.68)	5 times or less	HG-SR102(B)G5 1/5	12.3 (14.5)	10 times or less
	HC-RP103(B)G5 1/11	2.25 (2.60)		HG-SR102(B)G5 1/11	14.9 (17.1)	
	HC-RP103(B)G5 1/21	4.40 (4.75)		HG-SR102(B)G5 1/21	14.5 (16.7)	
	HC-RP103(B)G5 1/33	4.20 (4.55)		HG-SR102(B)G5 1/33	16.3 (18.5)	
	HC-RP103(B)G5 1/45	6.10 (6.45)		HG-SR102(B)G5 1/45	16.2 (18.4)	
	HC-RP153(B)G5 1/5	2.73 (3.08)		HG-SR152(B)G5 1/5	16.7 (18.9)	
	HC-RP153(B)G5 1/11	5.20 (5.55)		HG-SR152(B)G5 1/11	19.3 (21.5)	
	HC-RP153(B)G5 1/21	4.80 (5.15)		HG-SR152(B)G5 1/21	21.7 (23.9)	
	HC-RP153(B)G5 1/33	6.60 (6.95)		HG-SR152(B)G5 1/33	20.7 (22.9)	
	HC-RP153(B)G5 1/45	6.50 (6.85)		HG-SR152(B)G5 1/45	20.6 (22.8)	
	HC-RP203(B)G5 1/5	3.13 (3.48)		HG-SR202(B)G5 1/5	51.4 (61.1)	
	HC-RP203(B)G5 1/11	5.60 (5.95)		HG-SR202(B)G5 1/11	51.2 (60.9)	
	HC-RP203(B)G5 1/21	8.00 (8.35)		HG-SR202(B)G5 1/21	53.2 (62.9)	
	HC-RP203(B)G5 1/33	7.00 (7.35)		HG-SR202(B)G5 1/33	52.2 (61.9)	
	HC-RP203(B)G5 1/45	6.90 (7.25)		HG-SR202(B)G5 1/45	52.2 (61.9)	
	HC-RP353(B)G5 1/5	13.2 (16.7)		HG-SR352(B)G5 1/5	83.2 (92.8)	
	HC-RP353(B)G5 1/11	13.0 (16.5)		HG-SR352(B)G5 1/11	86.7 (96.3)	
	HC-RP353(B)G5 1/21	15.0 (18.5)		HG-SR352(B)G5 1/21	85.0 (94.6)	
	HC-RP353(B)G5 1/33	14.1 (17.6)		HG-SR352(B)G5 1/33	85.0 (94.6)	
	HC-RP503(B)G5 1/5	16.9 (20.4)		HG-SR502(B)G5 1/5	110 (119)	
HC-RP503(B)G5 1/11	20.5 (24.0)	HG-SR502(B)G5 1/11	108 (117)			
HC-RP503(B)G5 1/21	18.7 (22.2)	HG-SR502(B)G5 1/21	108 (117)			
Medium capacity, ultra-low inertia HC-RP series With shaft-output type gear reducer for high precision applications, flange mounting: G7	HC-RP103(B)G7 1/5	2.37 (2.72)	5 times or less	HG-SR102(B)G7 1/5	12.3 (14.5)	10 times or less
	HC-RP103(B)G7 1/11	2.25 (2.60)		HG-SR102(B)G7 1/11	15.0 (17.2)	
	HC-RP103(B)G7 1/21	4.40 (4.75)		HG-SR102(B)G7 1/21	14.5 (16.7)	
	HC-RP103(B)G7 1/33	4.20 (4.55)		HG-SR102(B)G7 1/33	16.3 (18.5)	
	HC-RP103(B)G7 1/45	6.20 (6.55)		HG-SR102(B)G7 1/45	16.3 (18.5)	
	HC-RP153(B)G7 1/5	2.77 (3.12)		HG-SR152(B)G7 1/5	16.7 (18.9)	
	HC-RP153(B)G7 1/11	5.30 (5.65)		HG-SR152(B)G7 1/11	19.4 (21.6)	
	HC-RP153(B)G7 1/21	4.80 (5.15)		HG-SR152(B)G7 1/21	21.7 (23.9)	
	HC-RP153(B)G7 1/33	6.60 (6.95)		HG-SR152(B)G7 1/33	20.7 (22.9)	
	HC-RP153(B)G7 1/45	6.60 (6.95)		HG-SR152(B)G7 1/45	20.7 (22.9)	
	HC-RP203(B)G7 1/5	3.17 (3.52)		HG-SR202(B)G7 1/5	51.7 (61.4)	
	HC-RP203(B)G7 1/11	5.70 (6.05)		HG-SR202(B)G7 1/11	51.3 (61.0)	
	HC-RP203(B)G7 1/21	8.00 (8.35)		HG-SR202(B)G7 1/21	53.3 (63.0)	
	HC-RP203(B)G7 1/33	7.00 (7.35)		HG-SR202(B)G7 1/33	52.2 (61.9)	
	HC-RP203(B)G7 1/45	7.00 (7.35)		HG-SR202(B)G7 1/45	52.2 (61.9)	
	HC-RP353(B)G7 1/5	13.5 (17.0)		HG-SR352(B)G7 1/5	83.5 (93.1)	
	HC-RP353(B)G7 1/11	13.1 (16.6)		HG-SR352(B)G7 1/11	87.0 (96.6)	
	HC-RP353(B)G7 1/21	15.1 (18.6)		HG-SR352(B)G7 1/21	85.1 (94.7)	
	HC-RP353(B)G7 1/33	14.1 (17.6)		HG-SR352(B)G7 1/33	85.1 (94.7)	
	HC-RP503(B)G7 1/5	17.2 (20.7)		HG-SR502(B)G7 1/5	111 (121)	
HC-RP503(B)G7 1/11	20.7 (24.2)	HG-SR502(B)G7 1/11	108 (117)			
HC-RP503(B)G7 1/21	18.8 (22.3)	HG-SR502(B)G7 1/21	108 (117)			

Part 9: Review on Replacement of Motor

(9) HC-LP/HC-UP/HF-JP series

Series	Target models			Replacement models		
	Model	Moment of inertia J $\times 10^{-4} \text{ kg}\cdot\text{m}^2$	Load inertia moment ratio	Example of replacement model	Moment of inertia J $\times 10^{-4} \text{ kg}\cdot\text{m}^2$	Load inertia moment ratio
Medium capacity, low inertia HC-LP series	HC-LP52(B)	3.10 (5.20)	10 times or less	HG-JR73(B)	2.09 (2.59)	10 times or less
	HC-LP102(B)	4.62 (6.72)		HG-JR153(B)	3.79 (4.29)	
	HC-LP152(B)	6.42 (8.52)		HG-JR353(B)	13.2 (15.4)	
	HC-LP202(B)	22.0 (32.0)		HG-JR503(B)	19.0 (21.2)	
	HC-LP302(B)	36.0 (46.0)				
Medium capacity, flat type HC-UP series	HC-UP72(B)	10.4 (12.5)	15 times or less	HG-UR72(B)	10.4 (12.5)	15 times or less
	HC-UP152(B)	22.1 (24.2)		HG-UR152(B)	22.1 (24.2)	
	HC-UP202(B)	38.2 (46.8)		HG-UR202(B)	38.2 (46.8)	
	HC-UP352(B)	76.5 (85.1)		HG-UR352(B)	76.5 (85.1)	
	HC-UP502(B)	115 (124)		HG-UR502(B)	115 (124)	
Large capacity, low inertia HF-JP series	HF-JP53(B)	1.52 (2.02)	10 times or less	HG-JR53(B)	1.52 (2.02)	10 times or less
	HF-JP534(B)			HG-JR534(B)		
	HF-JP73(B)	2.09 (2.59)		HG-JR73(B)	2.09 (2.59)	
	HF-JP734(B)			HG-JR734(B)		
	HF-JP103(B)	2.65 (3.15)		HG-JR103(B)	2.65 (3.15)	
	HF-JP1034(B)			HG-JR1034(B)		
	HF-JP153(B)	3.79 (4.29)		HG-JR153(B)	3.79 (4.29)	
	HF-JP1534(B)			HG-JR1534(B)		
	HF-JP203(B)	4.92 (5.42)		HG-JR203(B)	4.92 (5.42)	
	HF-JP2034(B)			HG-JR2034(B)		
	HF-JP353(B)	13.2 (15.4)		HG-JR353(B)	13.2 (15.4)	
	HF-JP3534(B)			HG-JR3534(B)		
	HF-JP503(B)	19.0 (21.2)		HG-JR503(B)	19.0 (21.2)	
HF-JP5034(B)	HG-JR5034(B)					
HF-JP703(B)	43.3 (52.9)	HG-JR703(B)	43.3 (52.9)			
HF-JP7034(B)		HG-JR7034(B)				
HF-JP903(B)	55.8 (65.4)	HG-JR903(B)	55.8 (65.4)			
HF-JP9034(B)		HG-JR9034(B)				
HF-JP11K1M(B)	220 (240)	HG-JR11K1M(B)	220 (240)			
HF-JP11K1M4(B)		HG-JR11K1M4(B)				
HF-JP15K1M(B)	315 (336)	HG-JR15K1M(B)	315 (336)			
HF-JP15K1M4(B)		HG-JR15K1M4(B)				

Part 9: Review on Replacement of Motor

(10) HA-LP series

Series	Target models			Replacement models		
	Model	Moment of inertia J $\times 10^{-4} \text{ kg}\cdot\text{m}^2$	Load inertia moment ratio	Example of replacement model	Moment of inertia J $\times 10^{-4} \text{ kg}\cdot\text{m}^2$	Load inertia moment ratio
Large capacity, low inertia HA-LP 1000 r/min series	HA-LP601(B) HA-LP6014(B)	105 (113)	10 times or less	HG-JR601(B) HG-JR6014(B)	176 (196)	10 times or less
	HA-LP801(B) HA-LP8014(B)	220 (293)		HG-JR801(B) HG-JR8014(B)	220 (240)	
	HA-LP12K1(B) HA-LP12K14(B)	295 (369)		HG-JR12K1(B) HG-JR12K14(B)	315 (336)	
	HA-LP15K1 HA-LP15K14	550		HG-JR15K1 HG-JR15K14	489	
	HA-LP20K1 HA-LP20K14	650		HG-JR20K1 HG-JR20K14	627	
	HA-LP25K1 HA-LP25K14	1080		HG-JR25K1 HG-JR25K14	764	
	HA-LP30K1 HA-LP30K14	1310		HG-JR30K1 HG-JR30K14	1377	
	HA-LP37K1 HA-LP37K14	1870		HG-JR37K1 HG-JR37K14	1637	
Large capacity, low inertia HA-LP 1500 r/min series	HA-LP701M(B) HA-LP701M4(B)	105 (113)	10 times or less	HG-JR701M(B) HG-JR701M4(B)	176 (196)	10 times or less
	HA-LP11K1M(B) HA-LP11K1M4(B)	220 (293)		HG-JR11K1M(B) HG-JR11K1M4(B)	220 (240)	
	HA-LP15K1M(B) HA-LP15K1M4(B)	295 (369)		HG-JR15K1M(B) HG-JR15K1M4(B)	315 (336)	
	HA-LP22K1M HA-LP22K1M4	550		HG-JR22K1M HG-JR22K1M4	489	
	HA-LP30K1M HA-LP30K1M4	650		HG-JR30K1M HG-JR30K1M4	627	
	HA-LP37K1M HA-LP37K1M4	1080		HG-JR37K1M HG-JR37K1M4	764	
	HA-LP45K1M4	1310		HG-JR45K1M4	1377	
	HA-LP50K1M4	1870		HG-JR55K1M4	1637	
Large capacity, low inertia HA-LP 2000 r/min series	HA-LP502	74.0	15 times or less	HG-SR502	99.7	15 times or less
	HA-LP702	94.2		HG-SR702	151	
	HA-LP11K2(B) HA-LP11K24(B)	105 (113)	10 times or less	HG-JR11K1M(B) HG-JR11K1M4(B)	220 (240)	10 times or less
	HA-LP15K2(B) HA-LP15K24(B)	220 (293)		HG-JR15K1M(B) HG-JR15K1M4(B)	315 (336)	
	HA-LP22K2(B) HA-LP22K24(B)	295 (369)		HG-JR22K1M HG-JR22K1M4	489	
	HA-LP30K2 HA-LP30K24	550		HG-JR30K1M HG-JR30K1M4	627	
	HA-LP37K2 HA-LP37K24	650		HG-JR37K1M4	764	
	HA-LP45K24	1080		HG-JR45K1M4	1377	
	HA-LP55K24	1310				

Part 9: Review on Replacement of Motor

(11) HA-LP series (compatible product)

Only flanges and shaft ends have compatibility in mounting. Please contact your local sales office regarding the servo motor model and its delivery, since it is developed upon receipt of order.

Series	Target product			Replacement product		
	Model	Moment of inertia J × 10 ⁻⁴ kg•m ²	Load moment inertia ratio	Model	Moment of inertia J × 10 ⁻⁴ kg•m ²	Load moment inertia ratio
Large capacity, low inertia HA-LP 1000 r/min series	HA-LP601(B) HA-LP6014(B)	105 (113)	10 times or less	HG-JR601R(B)-S_ HG-JR6014R(B) -S_	198 (218)	10 times or less
	HA-LP801(B) HA-LP8014(B)	220 (293)		HG-JR801R(B)-S_ HG-JR8014R(B)-S_	228 (248)	
	HA-LP12K1(B) HA-LP12K14(B)	295 (369)		HG-JR12K1R(B)-S_ HG-JR12K14R(B)-S_	323 (344)	
	HA-LP15K1 HA-LP15K14	550		HG-JR15K1R-S_ HG-JR15K14R-S_	487	
	HA-LP20K1 HA-LP20K14	650		HG-JR20K1R-S_ HG-JR20K14R-S_	625	
	HA-LP25K1 HA-LP25K14	1080		HG-JR25K1R-S_ HG-JR25K14R-S_	767	
	HA-LP30K1 HA-LP30K14	1310		HG-JR30K1R-S_ HG-JR30K14R-S_	1356	
	HA-LP37K1 HA-LP37K14	1870		HG-JR37K1R-S_ HG-JR37K14R-S_	1650	
Large capacity, low inertia HA-LP 1500 r/min series	HA-LP701M(B) HA-LP701M4(B)	105 (113)	10 times or less	HG-JR701MR(B)-S_ HG-JR701M4R(B)-S_	198 (218)	10 times or less
	HA-LP11K1M(B) HA-LP11K1M4(B)	220 (293)		HG-JR11K1MR(B)-S_ (□250) HG-JR11K1M4R(B)-S_ (□250)	228 (248)	
	HA-LP15K1M(B) HA-LP15K1M4(B)	295 (369)		HG-JR15K1MR(B)-S_ HG-JR15K1M4R(B)-S_	323 (344)	
	HA-LP22K1M HA-LP22K1M4	550		HG-JR22K1MR-S_ HG-JR22K1M4R-S_	487	
	HA-LP30K1M HA-LP30K1M4	650		HG-JR30K1MR-S_ HG-JR30K1M4R-S_	625	
	HA-LP37K1M HA-LP37K1M4	1080		HG-JR37K1MR-S_ HG-JR37K1M4R-S_	767	
	HA-LP45K1M4 HA-LP50K1M4	1310 1870		HG-JR45K1M4R-S_ HG-JR55K1M4R-S_	1356 1651	
	Large capacity, low inertia HA-LP 2000 r/min series	HA-LP502 HA-LP702		74.0 94.2	15 times or less	
HA-LP11K2(B) HA-LP11K24(B)		105 (113)	HG-JR11K1MR(B)-S_ (□200) HG-JR11K1M4R(B)-S_ (□200)	236 (256)		
Large capacity, low inertia HA-LP 2000 r/min series	HA-LP15K2(B) HA-LP15K24(B)	220 (293)	10 times or less	HG-JR11K1MR(B)-S_ (□250) HG-JR11K1M4R(B)-S_ (□250)	228 (248)	10 times or less
	HA-LP22K2(B) HA-LP22K24(B)	295 (369)		HG-JR15K1MR(B)-S_ HG-JR15K1M4R(B)-S_	323 (344)	
	HA-LP30K2 HA-LP30K24	550		HG-JR22K1MR-S_ HG-JR22K1M4R-S_	487	
	HA-LP37K2 HA-LP37K24	650		HG-JR30K1MR-S_ HG-JR30K1M4R-S_	625	
	HA-LP45K24 HA-LP55K24	1080 1310		HG-JR37K1M4R-S_ HG-JR45K1M4R-S_	767 1356	

Part 9: Review on Replacement of Motor

2.6 Comparison of Servo Motor Connector Specifications

(1) HF-KP/HF-MP series

Servo amplifier series	MR-J3 series	MR-J4 series																																												
Servo motor series	HF-KP/HF-MP	HG-KR/HG-MR																																												
Motor appearance																																														
Power connector	<table border="1"> <thead> <tr> <th colspan="2">Power connector Pin assignment</th> </tr> <tr> <th>Pin No.</th> <th>Signal name</th> </tr> </thead> <tbody> <tr> <td>1</td> <td>Earth</td> </tr> <tr> <td>2</td> <td>U</td> </tr> <tr> <td>3</td> <td>V</td> </tr> <tr> <td>4</td> <td>W</td> </tr> </tbody> </table>	Power connector Pin assignment		Pin No.	Signal name	1	Earth	2	U	3	V	4	W	<table border="1"> <thead> <tr> <th colspan="2">Power connector Pin assignment</th> </tr> <tr> <th>Pin No.</th> <th>Signal name</th> </tr> </thead> <tbody> <tr> <td>1</td> <td>Earth</td> </tr> <tr> <td>2</td> <td>U</td> </tr> <tr> <td>3</td> <td>V</td> </tr> <tr> <td>4</td> <td>W</td> </tr> </tbody> </table>	Power connector Pin assignment		Pin No.	Signal name	1	Earth	2	U	3	V	4	W																				
Power connector Pin assignment																																														
Pin No.	Signal name																																													
1	Earth																																													
2	U																																													
3	V																																													
4	W																																													
Power connector Pin assignment																																														
Pin No.	Signal name																																													
1	Earth																																													
2	U																																													
3	V																																													
4	W																																													
Encoder connector	<table border="1"> <thead> <tr> <th colspan="2">Encoder connector Pin assignment</th> </tr> <tr> <th>Pin No.</th> <th>Signal name</th> </tr> </thead> <tbody> <tr> <td>1</td> <td></td> </tr> <tr> <td>2</td> <td>BAT</td> </tr> <tr> <td>3</td> <td>P5</td> </tr> <tr> <td>4</td> <td>MRR</td> </tr> <tr> <td>5</td> <td>MR</td> </tr> <tr> <td>6</td> <td>LG</td> </tr> <tr> <td>7</td> <td></td> </tr> <tr> <td>8</td> <td></td> </tr> <tr> <td>9</td> <td>SHD</td> </tr> </tbody> </table>	Encoder connector Pin assignment		Pin No.	Signal name	1		2	BAT	3	P5	4	MRR	5	MR	6	LG	7		8		9	SHD	<table border="1"> <thead> <tr> <th colspan="2">Encoder connector Pin assignment</th> </tr> <tr> <th>Pin No.</th> <th>Signal name</th> </tr> </thead> <tbody> <tr> <td>1</td> <td></td> </tr> <tr> <td>2</td> <td>BAT</td> </tr> <tr> <td>3</td> <td>P5</td> </tr> <tr> <td>4</td> <td>MRR</td> </tr> <tr> <td>5</td> <td>MR</td> </tr> <tr> <td>6</td> <td>LG</td> </tr> <tr> <td>7</td> <td></td> </tr> <tr> <td>8</td> <td></td> </tr> <tr> <td>9</td> <td>SHD</td> </tr> </tbody> </table>	Encoder connector Pin assignment		Pin No.	Signal name	1		2	BAT	3	P5	4	MRR	5	MR	6	LG	7		8		9	SHD
Encoder connector Pin assignment																																														
Pin No.	Signal name																																													
1																																														
2	BAT																																													
3	P5																																													
4	MRR																																													
5	MR																																													
6	LG																																													
7																																														
8																																														
9	SHD																																													
Encoder connector Pin assignment																																														
Pin No.	Signal name																																													
1																																														
2	BAT																																													
3	P5																																													
4	MRR																																													
5	MR																																													
6	LG																																													
7																																														
8																																														
9	SHD																																													
Electromagnetic brake connector (Power connector)	<table border="1"> <thead> <tr> <th colspan="2">Electromagnetic brake connector Pin assignment</th> </tr> <tr> <th>Pin No.</th> <th>Signal name</th> </tr> </thead> <tbody> <tr> <td>1</td> <td>B1</td> </tr> <tr> <td>2</td> <td>B2</td> </tr> </tbody> </table>	Electromagnetic brake connector Pin assignment		Pin No.	Signal name	1	B1	2	B2	<table border="1"> <thead> <tr> <th colspan="2">Electromagnetic brake connector Pin assignment</th> </tr> <tr> <th>Pin No.</th> <th>Signal name</th> </tr> </thead> <tbody> <tr> <td>1</td> <td>B1</td> </tr> <tr> <td>2</td> <td>B2</td> </tr> </tbody> </table>	Electromagnetic brake connector Pin assignment		Pin No.	Signal name	1	B1	2	B2																												
Electromagnetic brake connector Pin assignment																																														
Pin No.	Signal name																																													
1	B1																																													
2	B2																																													
Electromagnetic brake connector Pin assignment																																														
Pin No.	Signal name																																													
1	B1																																													
2	B2																																													

Part 9: Review on Replacement of Motor

(2) HF-SP series

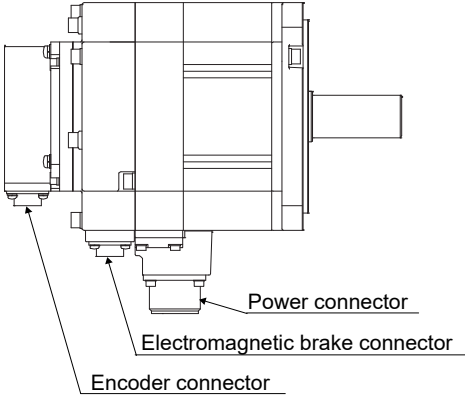
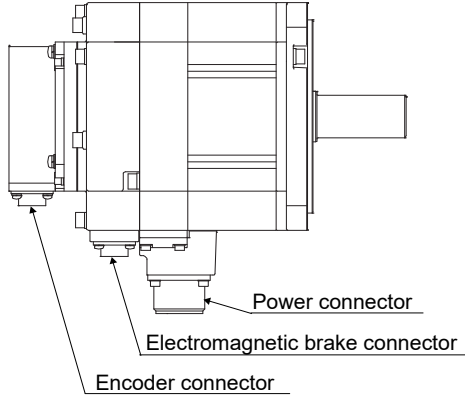
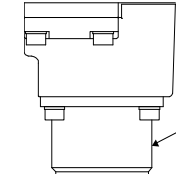
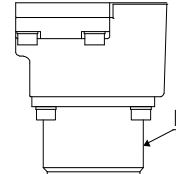
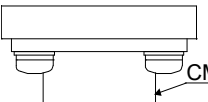
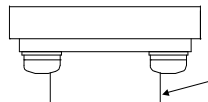
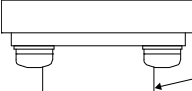
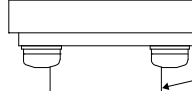
Servo amplifier series	MR-J3 series	MR-J4 series																																																
Servo motor series	HF-SP	HG-SR																																																
Target models	HF-SP51(B)/HF-SP81(B)/ HF-SP52(4)(B) to HF-SP152(4)(B)	HG-SR51(B)/HG-SR81(B)/ HG-SR52(4)(B) to HG-SR152(4)(B)																																																
Motor appearance																																																		
Power connector	 <table border="1" data-bbox="667 1048 912 1227"> <thead> <tr> <th colspan="2">Power connector Pin assignment</th> </tr> <tr> <th>Pin No.</th> <th>Signal name</th> </tr> </thead> <tbody> <tr> <td>A</td> <td>U</td> </tr> <tr> <td>B</td> <td>V</td> </tr> <tr> <td>C</td> <td>W</td> </tr> <tr> <td>D</td> <td>Earth</td> </tr> </tbody> </table>	Power connector Pin assignment		Pin No.	Signal name	A	U	B	V	C	W	D	Earth	 <table border="1" data-bbox="1184 1048 1430 1227"> <thead> <tr> <th colspan="2">Power connector Pin assignment</th> </tr> <tr> <th>Pin No.</th> <th>Signal name</th> </tr> </thead> <tbody> <tr> <td>A</td> <td>U</td> </tr> <tr> <td>B</td> <td>V</td> </tr> <tr> <td>C</td> <td>W</td> </tr> <tr> <td>D</td> <td>Earth</td> </tr> </tbody> </table>	Power connector Pin assignment		Pin No.	Signal name	A	U	B	V	C	W	D	Earth																								
Power connector Pin assignment																																																		
Pin No.	Signal name																																																	
A	U																																																	
B	V																																																	
C	W																																																	
D	Earth																																																	
Power connector Pin assignment																																																		
Pin No.	Signal name																																																	
A	U																																																	
B	V																																																	
C	W																																																	
D	Earth																																																	
Encoder connector (Note)	 <table border="1" data-bbox="667 1361 912 1706"> <thead> <tr> <th colspan="2">Encoder connector Pin assignment</th> </tr> <tr> <th>Pin No.</th> <th>Signal name</th> </tr> </thead> <tbody> <tr> <td>1</td> <td>MR</td> </tr> <tr> <td>2</td> <td>MRR</td> </tr> <tr> <td>3</td> <td></td> </tr> <tr> <td>4</td> <td>BAT</td> </tr> <tr> <td>5</td> <td>LG</td> </tr> <tr> <td>6</td> <td></td> </tr> <tr> <td>7</td> <td></td> </tr> <tr> <td>8</td> <td>P5</td> </tr> <tr> <td>9</td> <td></td> </tr> <tr> <td>10</td> <td>SHD</td> </tr> </tbody> </table>	Encoder connector Pin assignment		Pin No.	Signal name	1	MR	2	MRR	3		4	BAT	5	LG	6		7		8	P5	9		10	SHD	 <table border="1" data-bbox="1184 1361 1430 1706"> <thead> <tr> <th colspan="2">Encoder connector Pin assignment</th> </tr> <tr> <th>Pin No.</th> <th>Signal name</th> </tr> </thead> <tbody> <tr> <td>1</td> <td>MR</td> </tr> <tr> <td>2</td> <td>MRR</td> </tr> <tr> <td>3</td> <td></td> </tr> <tr> <td>4</td> <td>BAT</td> </tr> <tr> <td>5</td> <td>LG</td> </tr> <tr> <td>6</td> <td></td> </tr> <tr> <td>7</td> <td></td> </tr> <tr> <td>8</td> <td>P5</td> </tr> <tr> <td>9</td> <td></td> </tr> <tr> <td>10</td> <td>SHD</td> </tr> </tbody> </table>	Encoder connector Pin assignment		Pin No.	Signal name	1	MR	2	MRR	3		4	BAT	5	LG	6		7		8	P5	9		10	SHD
Encoder connector Pin assignment																																																		
Pin No.	Signal name																																																	
1	MR																																																	
2	MRR																																																	
3																																																		
4	BAT																																																	
5	LG																																																	
6																																																		
7																																																		
8	P5																																																	
9																																																		
10	SHD																																																	
Encoder connector Pin assignment																																																		
Pin No.	Signal name																																																	
1	MR																																																	
2	MRR																																																	
3																																																		
4	BAT																																																	
5	LG																																																	
6																																																		
7																																																		
8	P5																																																	
9																																																		
10	SHD																																																	
Electromagnetic brake connector (Note)	 <table border="1" data-bbox="641 1843 912 1975"> <thead> <tr> <th colspan="2">Power connector (with brake) Pin assignment</th> </tr> <tr> <th>Pin No.</th> <th>Signal name</th> </tr> </thead> <tbody> <tr> <td>1</td> <td>B1</td> </tr> <tr> <td>2</td> <td>B2</td> </tr> </tbody> </table>	Power connector (with brake) Pin assignment		Pin No.	Signal name	1	B1	2	B2	 <table border="1" data-bbox="1161 1843 1433 1975"> <thead> <tr> <th colspan="2">Power connector (with brake) Pin assignment</th> </tr> <tr> <th>Pin No.</th> <th>Signal name</th> </tr> </thead> <tbody> <tr> <td>1</td> <td>B1</td> </tr> <tr> <td>2</td> <td>B2</td> </tr> </tbody> </table>	Power connector (with brake) Pin assignment		Pin No.	Signal name	1	B1	2	B2																																
Power connector (with brake) Pin assignment																																																		
Pin No.	Signal name																																																	
1	B1																																																	
2	B2																																																	
Power connector (with brake) Pin assignment																																																		
Pin No.	Signal name																																																	
1	B1																																																	
2	B2																																																	

Note. Although the types of encoder and electromagnetic brake connector differ, they can be wired with the existing cables because the connector specifications have compatibility in wiring.

Part 9: Review on Replacement of Motor

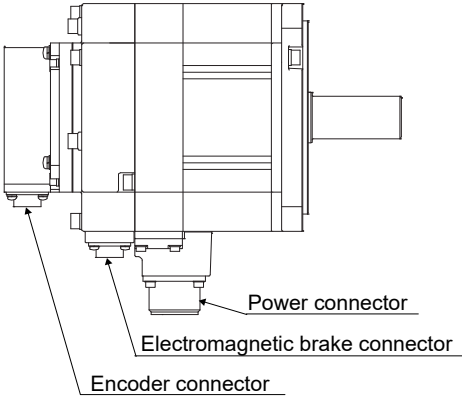
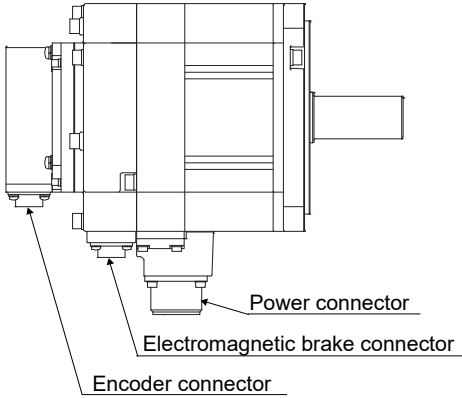
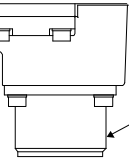
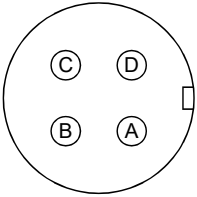
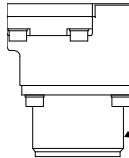
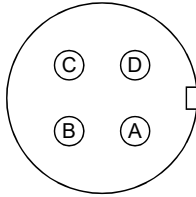
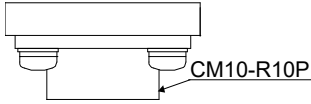
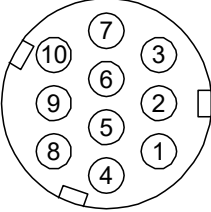
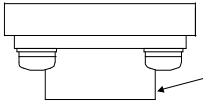
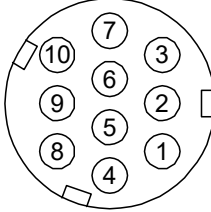
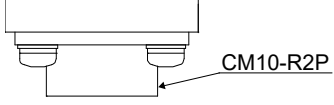
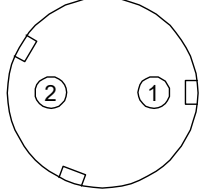
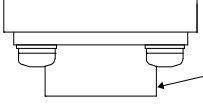
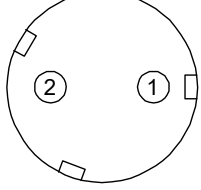
Servo amplifier series	MR-J3 series	MR-J4 series																																																
Servo motor series	HF-SP	HG-SR																																																
Target models	HF-SP121(B) to HF-SP421(B)/ HF-SP202(4)(B) to HF-SP702(4)(B)	HG-SR121(B) to HG-SR421(B)/ HG-SR202(4)(B) to HG-SR702(4)(B)																																																
Motor appearance																																																		
Power connector	 <p>MS3102A22-22P (3.5 kW or less, 5 kW) MS3102A32-17P (4.2 kW, 7 kW)</p>  <table border="1"> <thead> <tr> <th colspan="2">Power connector Pin assignment</th> </tr> <tr> <th>Pin No.</th> <th>Signal name</th> </tr> </thead> <tbody> <tr> <td>A</td> <td>U</td> </tr> <tr> <td>B</td> <td>V</td> </tr> <tr> <td>C</td> <td>W</td> </tr> <tr> <td>D</td> <td>Earth</td> </tr> </tbody> </table>	Power connector Pin assignment		Pin No.	Signal name	A	U	B	V	C	W	D	Earth	 <p>MS3102A22-22P (3.5 kW or less, 5 kW) MS3102A32-17P (4.2 kW, 7 kW)</p>  <table border="1"> <thead> <tr> <th colspan="2">Power connector Pin assignment</th> </tr> <tr> <th>Pin No.</th> <th>Signal name</th> </tr> </thead> <tbody> <tr> <td>A</td> <td>U</td> </tr> <tr> <td>B</td> <td>V</td> </tr> <tr> <td>C</td> <td>W</td> </tr> <tr> <td>D</td> <td>Earth</td> </tr> </tbody> </table>	Power connector Pin assignment		Pin No.	Signal name	A	U	B	V	C	W	D	Earth																								
Power connector Pin assignment																																																		
Pin No.	Signal name																																																	
A	U																																																	
B	V																																																	
C	W																																																	
D	Earth																																																	
Power connector Pin assignment																																																		
Pin No.	Signal name																																																	
A	U																																																	
B	V																																																	
C	W																																																	
D	Earth																																																	
Encoder connector (Note)	 <p>CM10-R10P</p>  <table border="1"> <thead> <tr> <th colspan="2">Encoder connector Pin assignment</th> </tr> <tr> <th>Pin No.</th> <th>Signal name</th> </tr> </thead> <tbody> <tr> <td>1</td> <td>MR</td> </tr> <tr> <td>2</td> <td>MRR</td> </tr> <tr> <td>3</td> <td></td> </tr> <tr> <td>4</td> <td>BAT</td> </tr> <tr> <td>5</td> <td>LG</td> </tr> <tr> <td>6</td> <td></td> </tr> <tr> <td>7</td> <td></td> </tr> <tr> <td>8</td> <td>P5</td> </tr> <tr> <td>9</td> <td></td> </tr> <tr> <td>10</td> <td>SHD</td> </tr> </tbody> </table>	Encoder connector Pin assignment		Pin No.	Signal name	1	MR	2	MRR	3		4	BAT	5	LG	6		7		8	P5	9		10	SHD	 <p>CMV1-R10P</p>  <table border="1"> <thead> <tr> <th colspan="2">Encoder connector Pin assignment</th> </tr> <tr> <th>Pin No.</th> <th>Signal name</th> </tr> </thead> <tbody> <tr> <td>1</td> <td>MR</td> </tr> <tr> <td>2</td> <td>MRR</td> </tr> <tr> <td>3</td> <td></td> </tr> <tr> <td>4</td> <td>BAT</td> </tr> <tr> <td>5</td> <td>LG</td> </tr> <tr> <td>6</td> <td></td> </tr> <tr> <td>7</td> <td></td> </tr> <tr> <td>8</td> <td>P5</td> </tr> <tr> <td>9</td> <td></td> </tr> <tr> <td>10</td> <td>SHD</td> </tr> </tbody> </table>	Encoder connector Pin assignment		Pin No.	Signal name	1	MR	2	MRR	3		4	BAT	5	LG	6		7		8	P5	9		10	SHD
Encoder connector Pin assignment																																																		
Pin No.	Signal name																																																	
1	MR																																																	
2	MRR																																																	
3																																																		
4	BAT																																																	
5	LG																																																	
6																																																		
7																																																		
8	P5																																																	
9																																																		
10	SHD																																																	
Encoder connector Pin assignment																																																		
Pin No.	Signal name																																																	
1	MR																																																	
2	MRR																																																	
3																																																		
4	BAT																																																	
5	LG																																																	
6																																																		
7																																																		
8	P5																																																	
9																																																		
10	SHD																																																	
Electromagnetic brake connector (Note)	 <p>CM10-R2P</p>  <table border="1"> <thead> <tr> <th colspan="2">Electromagnetic brake connector Pin assignment</th> </tr> <tr> <th>Pin No.</th> <th>Signal name</th> </tr> </thead> <tbody> <tr> <td>1</td> <td>B1</td> </tr> <tr> <td>2</td> <td>B2</td> </tr> </tbody> </table>	Electromagnetic brake connector Pin assignment		Pin No.	Signal name	1	B1	2	B2	 <p>CMV1-R2P</p>  <table border="1"> <thead> <tr> <th colspan="2">Electromagnetic brake connector Pin assignment</th> </tr> <tr> <th>Pin No.</th> <th>Signal name</th> </tr> </thead> <tbody> <tr> <td>1</td> <td>B1</td> </tr> <tr> <td>2</td> <td>B2</td> </tr> </tbody> </table>	Electromagnetic brake connector Pin assignment		Pin No.	Signal name	1	B1	2	B2																																
Electromagnetic brake connector Pin assignment																																																		
Pin No.	Signal name																																																	
1	B1																																																	
2	B2																																																	
Electromagnetic brake connector Pin assignment																																																		
Pin No.	Signal name																																																	
1	B1																																																	
2	B2																																																	

Note. Although the types of encoder and electromagnetic brake connector differ, they can be wired with the existing cables because the connector specifications have compatibility in wiring.

Part 9: Review on Replacement of Motor

(3) HC-RP series

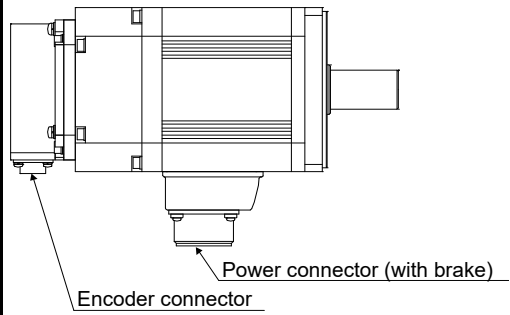
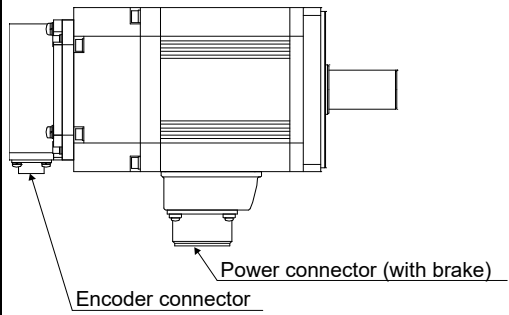
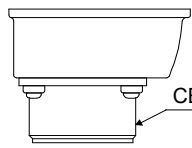
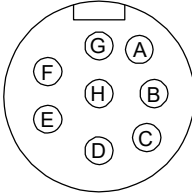
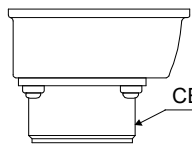
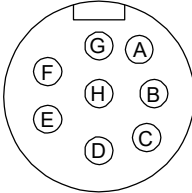
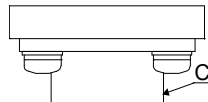
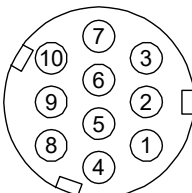
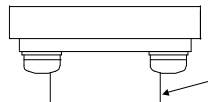
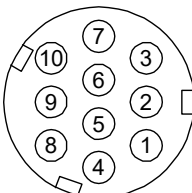
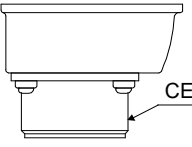
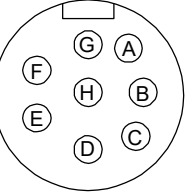
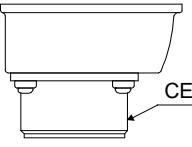
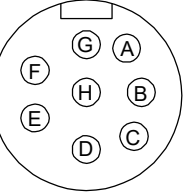
Servo amplifier series	MR-J3 series	MR-J4 series																																																
Servo motor series	HC-RP	HG-RR																																																
Target models	HC-RP103(B) to HC-RP203(B)	HG-RR103(B) to HG-RR203(B)																																																
Motor appearance	 <p>Encoder connector</p> <p>Power connector (with brake)</p>	 <p>Encoder connector</p> <p>Power connector (with brake)</p>																																																
Power connector	 <p>CE05-2A22-23P</p>  <table border="1"> <thead> <tr> <th colspan="2">Power connector Pin assignment</th> </tr> <tr> <th>Pin No.</th> <th>Signal name</th> </tr> </thead> <tbody> <tr><td>A</td><td>U</td></tr> <tr><td>B</td><td>V</td></tr> <tr><td>C</td><td>W</td></tr> <tr><td>D</td><td>Earth</td></tr> <tr><td>E</td><td></td></tr> <tr><td>F</td><td></td></tr> <tr><td>G</td><td></td></tr> <tr><td>H</td><td></td></tr> </tbody> </table>	Power connector Pin assignment		Pin No.	Signal name	A	U	B	V	C	W	D	Earth	E		F		G		H		 <p>CE05-2A22-23P</p>  <table border="1"> <thead> <tr> <th colspan="2">Power connector Pin assignment</th> </tr> <tr> <th>Pin No.</th> <th>Signal name</th> </tr> </thead> <tbody> <tr><td>A</td><td>U</td></tr> <tr><td>B</td><td>V</td></tr> <tr><td>C</td><td>W</td></tr> <tr><td>D</td><td>Earth</td></tr> <tr><td>E</td><td></td></tr> <tr><td>F</td><td></td></tr> <tr><td>G</td><td></td></tr> <tr><td>H</td><td></td></tr> </tbody> </table>	Power connector Pin assignment		Pin No.	Signal name	A	U	B	V	C	W	D	Earth	E		F		G		H									
Power connector Pin assignment																																																		
Pin No.	Signal name																																																	
A	U																																																	
B	V																																																	
C	W																																																	
D	Earth																																																	
E																																																		
F																																																		
G																																																		
H																																																		
Power connector Pin assignment																																																		
Pin No.	Signal name																																																	
A	U																																																	
B	V																																																	
C	W																																																	
D	Earth																																																	
E																																																		
F																																																		
G																																																		
H																																																		
Encoder connector (Note)	 <p>CM10-R10P</p>  <table border="1"> <thead> <tr> <th colspan="2">Encoder connector Pin assignment</th> </tr> <tr> <th>Pin No.</th> <th>Signal name</th> </tr> </thead> <tbody> <tr><td>1</td><td>MR</td></tr> <tr><td>2</td><td>MRR</td></tr> <tr><td>3</td><td></td></tr> <tr><td>4</td><td>BAT</td></tr> <tr><td>5</td><td>LG</td></tr> <tr><td>6</td><td></td></tr> <tr><td>7</td><td></td></tr> <tr><td>8</td><td>P5</td></tr> <tr><td>9</td><td></td></tr> <tr><td>10</td><td>SHD</td></tr> </tbody> </table>	Encoder connector Pin assignment		Pin No.	Signal name	1	MR	2	MRR	3		4	BAT	5	LG	6		7		8	P5	9		10	SHD	 <p>CMV1-R10P</p>  <table border="1"> <thead> <tr> <th colspan="2">Encoder connector Pin assignment</th> </tr> <tr> <th>Pin No.</th> <th>Signal name</th> </tr> </thead> <tbody> <tr><td>1</td><td>MR</td></tr> <tr><td>2</td><td>MRR</td></tr> <tr><td>3</td><td></td></tr> <tr><td>4</td><td>BAT</td></tr> <tr><td>5</td><td>LG</td></tr> <tr><td>6</td><td></td></tr> <tr><td>7</td><td></td></tr> <tr><td>8</td><td>P5</td></tr> <tr><td>9</td><td></td></tr> <tr><td>10</td><td>SHD</td></tr> </tbody> </table>	Encoder connector Pin assignment		Pin No.	Signal name	1	MR	2	MRR	3		4	BAT	5	LG	6		7		8	P5	9		10	SHD
Encoder connector Pin assignment																																																		
Pin No.	Signal name																																																	
1	MR																																																	
2	MRR																																																	
3																																																		
4	BAT																																																	
5	LG																																																	
6																																																		
7																																																		
8	P5																																																	
9																																																		
10	SHD																																																	
Encoder connector Pin assignment																																																		
Pin No.	Signal name																																																	
1	MR																																																	
2	MRR																																																	
3																																																		
4	BAT																																																	
5	LG																																																	
6																																																		
7																																																		
8	P5																																																	
9																																																		
10	SHD																																																	
Electromagnetic brake connector (Power connector)	 <p>CE05-2A22-23P</p>  <table border="1"> <thead> <tr> <th colspan="2">Power connector (with brake) Pin assignment</th> </tr> <tr> <th>Pin No.</th> <th>Signal name</th> </tr> </thead> <tbody> <tr><td>A</td><td>U</td></tr> <tr><td>B</td><td>V</td></tr> <tr><td>C</td><td>W</td></tr> <tr><td>D</td><td>Earth</td></tr> <tr><td>E</td><td></td></tr> <tr><td>F</td><td></td></tr> <tr><td>G</td><td>B1</td></tr> <tr><td>H</td><td>B2</td></tr> </tbody> </table>	Power connector (with brake) Pin assignment		Pin No.	Signal name	A	U	B	V	C	W	D	Earth	E		F		G	B1	H	B2	 <p>CE05-2A22-23P</p>  <table border="1"> <thead> <tr> <th colspan="2">Power connector (with brake) Pin assignment</th> </tr> <tr> <th>Pin No.</th> <th>Signal name</th> </tr> </thead> <tbody> <tr><td>A</td><td>U</td></tr> <tr><td>B</td><td>V</td></tr> <tr><td>C</td><td>W</td></tr> <tr><td>D</td><td>Earth</td></tr> <tr><td>E</td><td></td></tr> <tr><td>F</td><td></td></tr> <tr><td>G</td><td>B1</td></tr> <tr><td>H</td><td>B2</td></tr> </tbody> </table>	Power connector (with brake) Pin assignment		Pin No.	Signal name	A	U	B	V	C	W	D	Earth	E		F		G	B1	H	B2								
Power connector (with brake) Pin assignment																																																		
Pin No.	Signal name																																																	
A	U																																																	
B	V																																																	
C	W																																																	
D	Earth																																																	
E																																																		
F																																																		
G	B1																																																	
H	B2																																																	
Power connector (with brake) Pin assignment																																																		
Pin No.	Signal name																																																	
A	U																																																	
B	V																																																	
C	W																																																	
D	Earth																																																	
E																																																		
F																																																		
G	B1																																																	
H	B2																																																	

Note. Although the encoder connector type differs, it can be wired with the existing cables because the connector specifications have compatibility in wiring.

Part 9: Review on Replacement of Motor

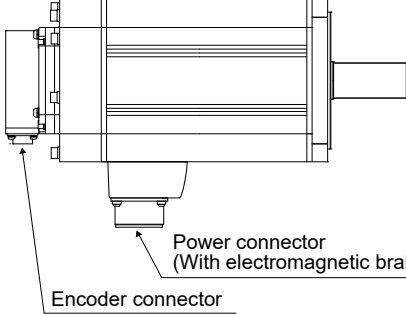
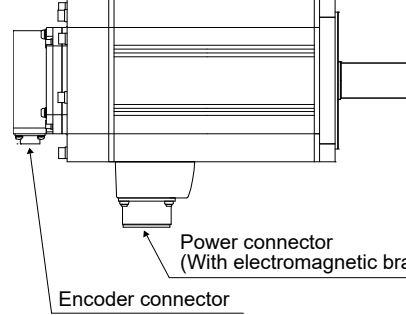
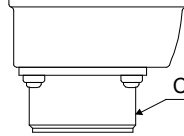
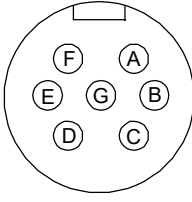
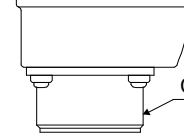
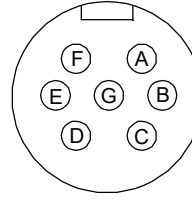
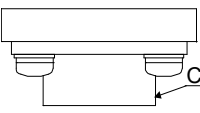
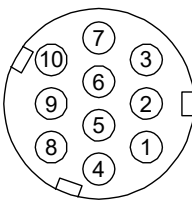
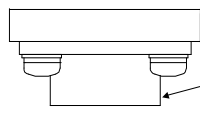
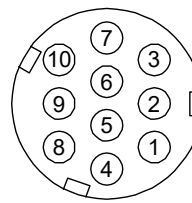
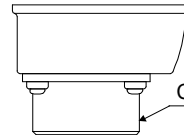
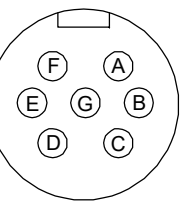
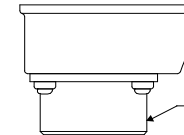
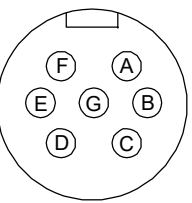
Servo amplifier series	MR-J3 series	MR-J4 series																																																
Servo motor series	HC-RP	HG-RR																																																
Target models	HC-RP353(B)/HC-RP503(B)	HG-RR353(B)/HG-RR503(B)																																																
Motor appearance	 <p>Encoder connector</p> <p>Power connector (With electromagnetic brake)</p>	 <p>Encoder connector</p> <p>Power connector (With electromagnetic brake)</p>																																																
Power connector	 <p>CE05-2A24-10P</p>  <table border="1"> <thead> <tr> <th colspan="2">Power connector Pin assignment</th> </tr> <tr> <th>Pin No.</th> <th>Signal name</th> </tr> </thead> <tbody> <tr><td>A</td><td>U</td></tr> <tr><td>B</td><td>V</td></tr> <tr><td>C</td><td>W</td></tr> <tr><td>D</td><td>Earth</td></tr> <tr><td>E</td><td></td></tr> <tr><td>F</td><td></td></tr> <tr><td>G</td><td></td></tr> </tbody> </table>	Power connector Pin assignment		Pin No.	Signal name	A	U	B	V	C	W	D	Earth	E		F		G		 <p>CE05-2A24-10P</p>  <table border="1"> <thead> <tr> <th colspan="2">Power connector Pin assignment</th> </tr> <tr> <th>Pin No.</th> <th>Signal name</th> </tr> </thead> <tbody> <tr><td>A</td><td>U</td></tr> <tr><td>B</td><td>V</td></tr> <tr><td>C</td><td>W</td></tr> <tr><td>D</td><td>Earth</td></tr> <tr><td>E</td><td></td></tr> <tr><td>F</td><td></td></tr> <tr><td>G</td><td></td></tr> </tbody> </table>	Power connector Pin assignment		Pin No.	Signal name	A	U	B	V	C	W	D	Earth	E		F		G													
Power connector Pin assignment																																																		
Pin No.	Signal name																																																	
A	U																																																	
B	V																																																	
C	W																																																	
D	Earth																																																	
E																																																		
F																																																		
G																																																		
Power connector Pin assignment																																																		
Pin No.	Signal name																																																	
A	U																																																	
B	V																																																	
C	W																																																	
D	Earth																																																	
E																																																		
F																																																		
G																																																		
Encoder connector (Note)	 <p>CM10-R10P</p>  <table border="1"> <thead> <tr> <th colspan="2">Encoder connector Pin assignment</th> </tr> <tr> <th>Pin No.</th> <th>Signal name</th> </tr> </thead> <tbody> <tr><td>1</td><td>MR</td></tr> <tr><td>2</td><td>MRR</td></tr> <tr><td>3</td><td></td></tr> <tr><td>4</td><td>BAT</td></tr> <tr><td>5</td><td>LG</td></tr> <tr><td>6</td><td></td></tr> <tr><td>7</td><td></td></tr> <tr><td>8</td><td>P5</td></tr> <tr><td>9</td><td></td></tr> <tr><td>10</td><td>SHD</td></tr> </tbody> </table>	Encoder connector Pin assignment		Pin No.	Signal name	1	MR	2	MRR	3		4	BAT	5	LG	6		7		8	P5	9		10	SHD	 <p>CMV1-R10P</p>  <table border="1"> <thead> <tr> <th colspan="2">Encoder connector Pin assignment</th> </tr> <tr> <th>Pin No.</th> <th>Signal name</th> </tr> </thead> <tbody> <tr><td>1</td><td>MR</td></tr> <tr><td>2</td><td>MRR</td></tr> <tr><td>3</td><td></td></tr> <tr><td>4</td><td>BAT</td></tr> <tr><td>5</td><td>LG</td></tr> <tr><td>6</td><td></td></tr> <tr><td>7</td><td></td></tr> <tr><td>8</td><td>P5</td></tr> <tr><td>9</td><td></td></tr> <tr><td>10</td><td>SHD</td></tr> </tbody> </table>	Encoder connector Pin assignment		Pin No.	Signal name	1	MR	2	MRR	3		4	BAT	5	LG	6		7		8	P5	9		10	SHD
Encoder connector Pin assignment																																																		
Pin No.	Signal name																																																	
1	MR																																																	
2	MRR																																																	
3																																																		
4	BAT																																																	
5	LG																																																	
6																																																		
7																																																		
8	P5																																																	
9																																																		
10	SHD																																																	
Encoder connector Pin assignment																																																		
Pin No.	Signal name																																																	
1	MR																																																	
2	MRR																																																	
3																																																		
4	BAT																																																	
5	LG																																																	
6																																																		
7																																																		
8	P5																																																	
9																																																		
10	SHD																																																	
Electromagnetic brake connector (Power connector)	 <p>CE05-2A24-10P</p>  <table border="1"> <thead> <tr> <th colspan="2">Power connector (with brake) Pin assignment</th> </tr> <tr> <th>Pin No.</th> <th>Signal name</th> </tr> </thead> <tbody> <tr><td>A</td><td>U</td></tr> <tr><td>B</td><td>V</td></tr> <tr><td>C</td><td>W</td></tr> <tr><td>D</td><td>Earth</td></tr> <tr><td>E</td><td>B1</td></tr> <tr><td>F</td><td>B2</td></tr> <tr><td>G</td><td></td></tr> </tbody> </table>	Power connector (with brake) Pin assignment		Pin No.	Signal name	A	U	B	V	C	W	D	Earth	E	B1	F	B2	G		 <p>CE05-2A24-10P</p>  <table border="1"> <thead> <tr> <th colspan="2">Power connector (with brake) Pin assignment</th> </tr> <tr> <th>Pin No.</th> <th>Signal name</th> </tr> </thead> <tbody> <tr><td>A</td><td>U</td></tr> <tr><td>B</td><td>V</td></tr> <tr><td>C</td><td>W</td></tr> <tr><td>D</td><td>Earth</td></tr> <tr><td>E</td><td>B1</td></tr> <tr><td>F</td><td>B2</td></tr> <tr><td>G</td><td></td></tr> </tbody> </table>	Power connector (with brake) Pin assignment		Pin No.	Signal name	A	U	B	V	C	W	D	Earth	E	B1	F	B2	G													
Power connector (with brake) Pin assignment																																																		
Pin No.	Signal name																																																	
A	U																																																	
B	V																																																	
C	W																																																	
D	Earth																																																	
E	B1																																																	
F	B2																																																	
G																																																		
Power connector (with brake) Pin assignment																																																		
Pin No.	Signal name																																																	
A	U																																																	
B	V																																																	
C	W																																																	
D	Earth																																																	
E	B1																																																	
F	B2																																																	
G																																																		

Note. Although the encoder connector type differs, it can be wired with the existing cables because the connector specifications have compatibility in wiring.

Part 9: Review on Replacement of Motor

(4) HC-LP series

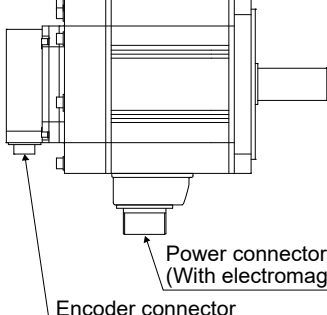
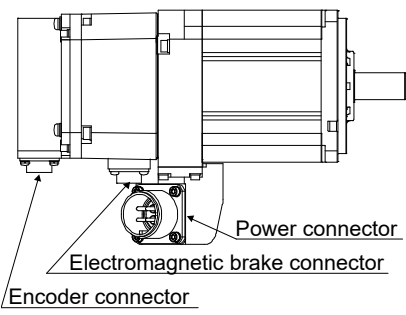
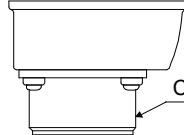
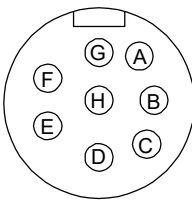
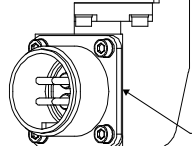
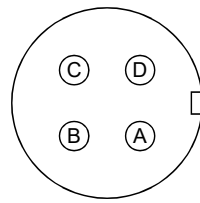
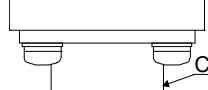
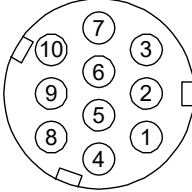
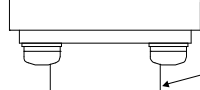
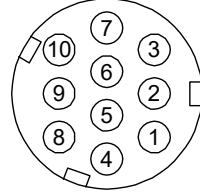
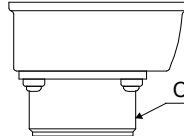
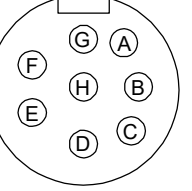
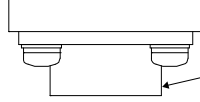
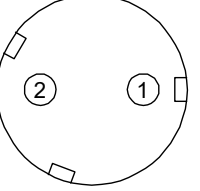
Servo amplifier series	MR-J3 series	MR-J4 series																																																
Servo motor series	HC-LP	HG-JR																																																
Target models	HC-LP52(B)/HC-LP102(B)	HG-JR73(B)/HG-JR153(B)																																																
Motor appearance	 <p>Power connector (With electromagnetic brake) Encoder connector</p>	 <p>Power connector Electromagnetic brake connector Encoder connector</p>																																																
Power connector (Note 1)	 <p>CE05-2A22-23P</p>  <table border="1"> <thead> <tr> <th colspan="2">Power connector Pin assignment</th> </tr> <tr> <th>Pin No.</th> <th>Signal name</th> </tr> </thead> <tbody> <tr><td>A</td><td>U</td></tr> <tr><td>B</td><td>V</td></tr> <tr><td>C</td><td>W</td></tr> <tr><td>D</td><td>Earth</td></tr> <tr><td>E</td><td></td></tr> <tr><td>F</td><td></td></tr> <tr><td>G</td><td></td></tr> <tr><td>H</td><td></td></tr> </tbody> </table>	Power connector Pin assignment		Pin No.	Signal name	A	U	B	V	C	W	D	Earth	E		F		G		H		 <p>MS3102A18-10I</p>  <table border="1"> <thead> <tr> <th colspan="2">Power connector Pin assignment</th> </tr> <tr> <th>Pin No.</th> <th>Signal name</th> </tr> </thead> <tbody> <tr><td>A</td><td>U</td></tr> <tr><td>B</td><td>V</td></tr> <tr><td>C</td><td>W</td></tr> <tr><td>D</td><td>Earth</td></tr> </tbody> </table>	Power connector Pin assignment		Pin No.	Signal name	A	U	B	V	C	W	D	Earth																
Power connector Pin assignment																																																		
Pin No.	Signal name																																																	
A	U																																																	
B	V																																																	
C	W																																																	
D	Earth																																																	
E																																																		
F																																																		
G																																																		
H																																																		
Power connector Pin assignment																																																		
Pin No.	Signal name																																																	
A	U																																																	
B	V																																																	
C	W																																																	
D	Earth																																																	
Encoder connector (Note 2)	 <p>CM10-R10P</p>  <table border="1"> <thead> <tr> <th colspan="2">Encoder connector Pin assignment</th> </tr> <tr> <th>Pin No.</th> <th>Signal name</th> </tr> </thead> <tbody> <tr><td>1</td><td>MR</td></tr> <tr><td>2</td><td>MRR</td></tr> <tr><td>3</td><td></td></tr> <tr><td>4</td><td>BAT</td></tr> <tr><td>5</td><td>LG</td></tr> <tr><td>6</td><td></td></tr> <tr><td>7</td><td></td></tr> <tr><td>8</td><td>P5</td></tr> <tr><td>9</td><td></td></tr> <tr><td>10</td><td>SHD</td></tr> </tbody> </table>	Encoder connector Pin assignment		Pin No.	Signal name	1	MR	2	MRR	3		4	BAT	5	LG	6		7		8	P5	9		10	SHD	 <p>CMV1-R10P</p>  <table border="1"> <thead> <tr> <th colspan="2">Encoder connector Pin assignment</th> </tr> <tr> <th>Pin No.</th> <th>Signal name</th> </tr> </thead> <tbody> <tr><td>1</td><td>MR</td></tr> <tr><td>2</td><td>MRR</td></tr> <tr><td>3</td><td></td></tr> <tr><td>4</td><td>BAT</td></tr> <tr><td>5</td><td>LG</td></tr> <tr><td>6</td><td></td></tr> <tr><td>7</td><td></td></tr> <tr><td>8</td><td>P5</td></tr> <tr><td>9</td><td></td></tr> <tr><td>10</td><td>SHD</td></tr> </tbody> </table>	Encoder connector Pin assignment		Pin No.	Signal name	1	MR	2	MRR	3		4	BAT	5	LG	6		7		8	P5	9		10	SHD
Encoder connector Pin assignment																																																		
Pin No.	Signal name																																																	
1	MR																																																	
2	MRR																																																	
3																																																		
4	BAT																																																	
5	LG																																																	
6																																																		
7																																																		
8	P5																																																	
9																																																		
10	SHD																																																	
Encoder connector Pin assignment																																																		
Pin No.	Signal name																																																	
1	MR																																																	
2	MRR																																																	
3																																																		
4	BAT																																																	
5	LG																																																	
6																																																		
7																																																		
8	P5																																																	
9																																																		
10	SHD																																																	
Electromagnetic brake connector (Power connector)	 <p>CE05-2A22-23P</p>  <table border="1"> <thead> <tr> <th colspan="2">Power connector (with brake) Pin assignment</th> </tr> <tr> <th>Pin No.</th> <th>Signal name</th> </tr> </thead> <tbody> <tr><td>A</td><td>U</td></tr> <tr><td>B</td><td>V</td></tr> <tr><td>C</td><td>W</td></tr> <tr><td>D</td><td>Earth</td></tr> <tr><td>E</td><td></td></tr> <tr><td>F</td><td></td></tr> <tr><td>G</td><td>B1</td></tr> <tr><td>H</td><td>B2</td></tr> </tbody> </table>	Power connector (with brake) Pin assignment		Pin No.	Signal name	A	U	B	V	C	W	D	Earth	E		F		G	B1	H	B2	 <p>CMV1-R2P</p>  <table border="1"> <thead> <tr> <th colspan="2">Electromagnetic brake connector Pin assignment</th> </tr> <tr> <th>Pin No.</th> <th>Signal name</th> </tr> </thead> <tbody> <tr><td>1</td><td>B1</td></tr> <tr><td>2</td><td>B2</td></tr> </tbody> </table>	Electromagnetic brake connector Pin assignment		Pin No.	Signal name	1	B1	2	B2																				
Power connector (with brake) Pin assignment																																																		
Pin No.	Signal name																																																	
A	U																																																	
B	V																																																	
C	W																																																	
D	Earth																																																	
E																																																		
F																																																		
G	B1																																																	
H	B2																																																	
Electromagnetic brake connector Pin assignment																																																		
Pin No.	Signal name																																																	
1	B1																																																	
2	B2																																																	

- Note 1. The capacity of the servo amplifier is changed. Another power cable is required.
 Note 2. Although the encoder connector type differs, it can be wired with the existing cables because the connector specifications have compatibility in wiring.

Part 9: Review on Replacement of Motor

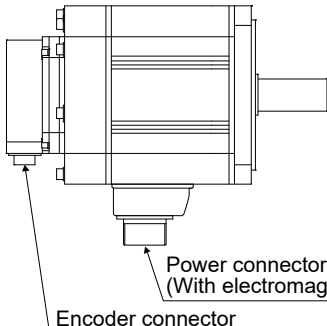
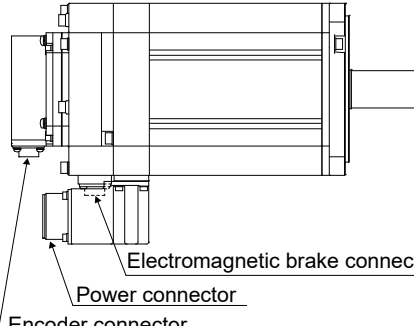
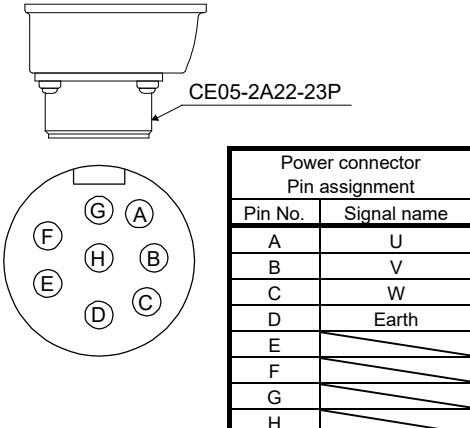
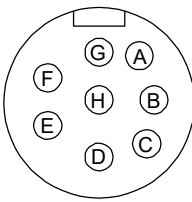
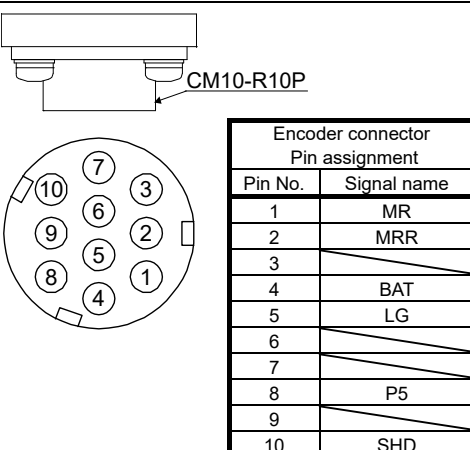
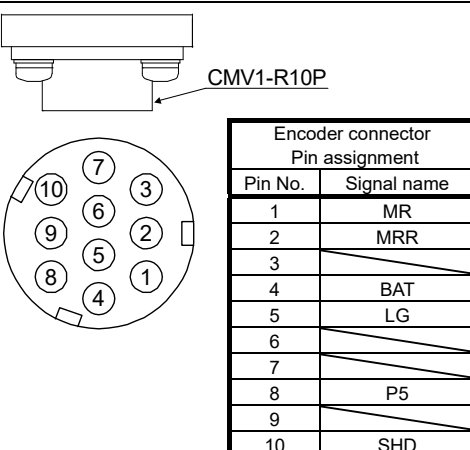
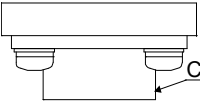
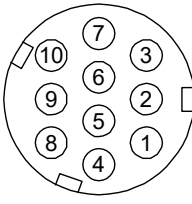
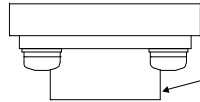
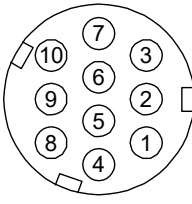
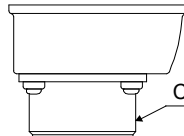
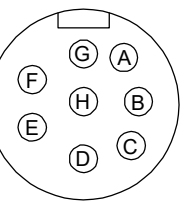
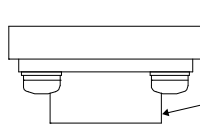
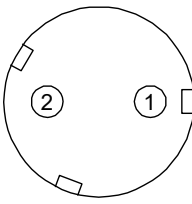
Servo amplifier series	MR-J3 series	MR-J4 series																																																
Servo motor series	HC-LP	HG-JR																																																
Target models	HC-LP152(B)	HG-JR353(B)																																																
Motor appearance	 <p>Power connector (With electromagnetic brake)</p> <p>Encoder connector</p>	 <p>Electromagnetic brake connector</p> <p>Power connector</p> <p>Encoder connector</p>																																																
Power connector (Note 1)	 <p>CE05-2A22-23P</p>  <table border="1"> <thead> <tr> <th colspan="2">Power connector Pin assignment</th> </tr> <tr> <th>Pin No.</th> <th>Signal name</th> </tr> </thead> <tbody> <tr><td>A</td><td>U</td></tr> <tr><td>B</td><td>V</td></tr> <tr><td>C</td><td>W</td></tr> <tr><td>D</td><td>Earth</td></tr> <tr><td>E</td><td></td></tr> <tr><td>F</td><td></td></tr> <tr><td>G</td><td></td></tr> <tr><td>H</td><td></td></tr> </tbody> </table>	Power connector Pin assignment		Pin No.	Signal name	A	U	B	V	C	W	D	Earth	E		F		G		H		 <p>MS3102A22-22P</p>  <table border="1"> <thead> <tr> <th colspan="2">Power connector Pin assignment</th> </tr> <tr> <th>Pin No.</th> <th>Signal name</th> </tr> </thead> <tbody> <tr><td>A</td><td>U</td></tr> <tr><td>B</td><td>V</td></tr> <tr><td>C</td><td>W</td></tr> <tr><td>D</td><td>Earth</td></tr> </tbody> </table>	Power connector Pin assignment		Pin No.	Signal name	A	U	B	V	C	W	D	Earth																
Power connector Pin assignment																																																		
Pin No.	Signal name																																																	
A	U																																																	
B	V																																																	
C	W																																																	
D	Earth																																																	
E																																																		
F																																																		
G																																																		
H																																																		
Power connector Pin assignment																																																		
Pin No.	Signal name																																																	
A	U																																																	
B	V																																																	
C	W																																																	
D	Earth																																																	
Encoder connector (Note 2)	 <p>CM10-R10P</p>  <table border="1"> <thead> <tr> <th colspan="2">Encoder connector Pin assignment</th> </tr> <tr> <th>Pin No.</th> <th>Signal name</th> </tr> </thead> <tbody> <tr><td>1</td><td>MR</td></tr> <tr><td>2</td><td>MRR</td></tr> <tr><td>3</td><td></td></tr> <tr><td>4</td><td>BAT</td></tr> <tr><td>5</td><td>LG</td></tr> <tr><td>6</td><td></td></tr> <tr><td>7</td><td></td></tr> <tr><td>8</td><td>P5</td></tr> <tr><td>9</td><td></td></tr> <tr><td>10</td><td>SHD</td></tr> </tbody> </table>	Encoder connector Pin assignment		Pin No.	Signal name	1	MR	2	MRR	3		4	BAT	5	LG	6		7		8	P5	9		10	SHD	 <p>CMV1-R10P</p>  <table border="1"> <thead> <tr> <th colspan="2">Encoder connector Pin assignment</th> </tr> <tr> <th>Pin No.</th> <th>Signal name</th> </tr> </thead> <tbody> <tr><td>1</td><td>MR</td></tr> <tr><td>2</td><td>MRR</td></tr> <tr><td>3</td><td></td></tr> <tr><td>4</td><td>BAT</td></tr> <tr><td>5</td><td>LG</td></tr> <tr><td>6</td><td></td></tr> <tr><td>7</td><td></td></tr> <tr><td>8</td><td>P5</td></tr> <tr><td>9</td><td></td></tr> <tr><td>10</td><td>SHD</td></tr> </tbody> </table>	Encoder connector Pin assignment		Pin No.	Signal name	1	MR	2	MRR	3		4	BAT	5	LG	6		7		8	P5	9		10	SHD
Encoder connector Pin assignment																																																		
Pin No.	Signal name																																																	
1	MR																																																	
2	MRR																																																	
3																																																		
4	BAT																																																	
5	LG																																																	
6																																																		
7																																																		
8	P5																																																	
9																																																		
10	SHD																																																	
Encoder connector Pin assignment																																																		
Pin No.	Signal name																																																	
1	MR																																																	
2	MRR																																																	
3																																																		
4	BAT																																																	
5	LG																																																	
6																																																		
7																																																		
8	P5																																																	
9																																																		
10	SHD																																																	
Electromagnetic brake connector (Power connector)	 <p>CE05-2A22-23P</p>  <table border="1"> <thead> <tr> <th colspan="2">Power connector (with brake) Pin assignment</th> </tr> <tr> <th>Pin No.</th> <th>Signal name</th> </tr> </thead> <tbody> <tr><td>A</td><td>U</td></tr> <tr><td>B</td><td>V</td></tr> <tr><td>C</td><td>W</td></tr> <tr><td>D</td><td>Earth</td></tr> <tr><td>E</td><td></td></tr> <tr><td>F</td><td></td></tr> <tr><td>G</td><td>B1</td></tr> <tr><td>H</td><td>B2</td></tr> </tbody> </table>	Power connector (with brake) Pin assignment		Pin No.	Signal name	A	U	B	V	C	W	D	Earth	E		F		G	B1	H	B2	 <p>CMV1-R2P</p>  <table border="1"> <thead> <tr> <th colspan="2">Electromagnetic brake connector Pin assignment</th> </tr> <tr> <th>Pin No.</th> <th>Signal name</th> </tr> </thead> <tbody> <tr><td>1</td><td>B1</td></tr> <tr><td>2</td><td>B2</td></tr> </tbody> </table>	Electromagnetic brake connector Pin assignment		Pin No.	Signal name	1	B1	2	B2																				
Power connector (with brake) Pin assignment																																																		
Pin No.	Signal name																																																	
A	U																																																	
B	V																																																	
C	W																																																	
D	Earth																																																	
E																																																		
F																																																		
G	B1																																																	
H	B2																																																	
Electromagnetic brake connector Pin assignment																																																		
Pin No.	Signal name																																																	
1	B1																																																	
2	B2																																																	

- Note 1. The capacity of the servo amplifier is changed. Another power cable is required.
- Note 2. Although the encoder connector type differs, it can be wired with the existing cables because the connector specifications have compatibility in wiring.

Part 9: Review on Replacement of Motor

Servo amplifier series	MR-J3 series	MR-J4 series																																																
Servo motor series	HC-LP	HG-JR																																																
Target models	HC-LP202(B)/HC-LP302(B)	HG-JR353(B)/HG-JR503(B)																																																
Motor appearance																																																		
Power connector	<table border="1"> <thead> <tr> <th colspan="2">Power connector Pin assignment</th> </tr> <tr> <th>Pin No.</th> <th>Signal name</th> </tr> </thead> <tbody> <tr><td>A</td><td>U</td></tr> <tr><td>B</td><td>V</td></tr> <tr><td>C</td><td>W</td></tr> <tr><td>D</td><td>Earth</td></tr> <tr><td>E</td><td></td></tr> <tr><td>F</td><td></td></tr> <tr><td>G</td><td></td></tr> </tbody> </table>	Power connector Pin assignment		Pin No.	Signal name	A	U	B	V	C	W	D	Earth	E		F		G		<table border="1"> <thead> <tr> <th colspan="2">Power connector Pin assignment</th> </tr> <tr> <th>Pin No.</th> <th>Signal name</th> </tr> </thead> <tbody> <tr><td>A</td><td>U</td></tr> <tr><td>B</td><td>V</td></tr> <tr><td>C</td><td>W</td></tr> <tr><td>D</td><td>Earth</td></tr> </tbody> </table>	Power connector Pin assignment		Pin No.	Signal name	A	U	B	V	C	W	D	Earth																		
Power connector Pin assignment																																																		
Pin No.	Signal name																																																	
A	U																																																	
B	V																																																	
C	W																																																	
D	Earth																																																	
E																																																		
F																																																		
G																																																		
Power connector Pin assignment																																																		
Pin No.	Signal name																																																	
A	U																																																	
B	V																																																	
C	W																																																	
D	Earth																																																	
Encoder connector (Note)	<table border="1"> <thead> <tr> <th colspan="2">Encoder connector Pin assignment</th> </tr> <tr> <th>Pin No.</th> <th>Signal name</th> </tr> </thead> <tbody> <tr><td>1</td><td>MR</td></tr> <tr><td>2</td><td>MRR</td></tr> <tr><td>3</td><td></td></tr> <tr><td>4</td><td>BAT</td></tr> <tr><td>5</td><td>LG</td></tr> <tr><td>6</td><td></td></tr> <tr><td>7</td><td></td></tr> <tr><td>8</td><td>P5</td></tr> <tr><td>9</td><td></td></tr> <tr><td>10</td><td>SHD</td></tr> </tbody> </table>	Encoder connector Pin assignment		Pin No.	Signal name	1	MR	2	MRR	3		4	BAT	5	LG	6		7		8	P5	9		10	SHD	<table border="1"> <thead> <tr> <th colspan="2">Encoder connector Pin assignment</th> </tr> <tr> <th>Pin No.</th> <th>Signal name</th> </tr> </thead> <tbody> <tr><td>1</td><td>MR</td></tr> <tr><td>2</td><td>MRR</td></tr> <tr><td>3</td><td></td></tr> <tr><td>4</td><td>BAT</td></tr> <tr><td>5</td><td>LG</td></tr> <tr><td>6</td><td></td></tr> <tr><td>7</td><td></td></tr> <tr><td>8</td><td>P5</td></tr> <tr><td>9</td><td></td></tr> <tr><td>10</td><td>SHD</td></tr> </tbody> </table>	Encoder connector Pin assignment		Pin No.	Signal name	1	MR	2	MRR	3		4	BAT	5	LG	6		7		8	P5	9		10	SHD
Encoder connector Pin assignment																																																		
Pin No.	Signal name																																																	
1	MR																																																	
2	MRR																																																	
3																																																		
4	BAT																																																	
5	LG																																																	
6																																																		
7																																																		
8	P5																																																	
9																																																		
10	SHD																																																	
Encoder connector Pin assignment																																																		
Pin No.	Signal name																																																	
1	MR																																																	
2	MRR																																																	
3																																																		
4	BAT																																																	
5	LG																																																	
6																																																		
7																																																		
8	P5																																																	
9																																																		
10	SHD																																																	
Electromagnetic brake connector	<table border="1"> <thead> <tr> <th colspan="2">Electromagnetic brake connector Pin assignment</th> </tr> <tr> <th>Pin No.</th> <th>Signal name</th> </tr> </thead> <tbody> <tr><td>A</td><td>B1</td></tr> <tr><td>B</td><td>B2</td></tr> </tbody> </table>	Electromagnetic brake connector Pin assignment		Pin No.	Signal name	A	B1	B	B2	<table border="1"> <thead> <tr> <th colspan="2">Electromagnetic brake connector Pin assignment</th> </tr> <tr> <th>Pin No.</th> <th>Signal name</th> </tr> </thead> <tbody> <tr><td>1</td><td>B1</td></tr> <tr><td>2</td><td>B2</td></tr> </tbody> </table>	Electromagnetic brake connector Pin assignment		Pin No.	Signal name	1	B1	2	B2																																
Electromagnetic brake connector Pin assignment																																																		
Pin No.	Signal name																																																	
A	B1																																																	
B	B2																																																	
Electromagnetic brake connector Pin assignment																																																		
Pin No.	Signal name																																																	
1	B1																																																	
2	B2																																																	

Note. Although the encoder connector type differs, it can be wired with the existing cables because the connector specifications have compatibility in wiring.

Part 9: Review on Replacement of Motor

(5) HC-UP series

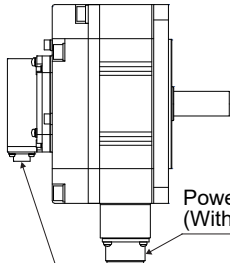
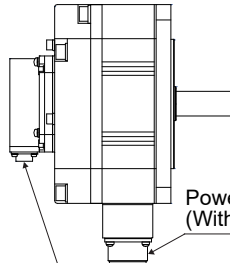
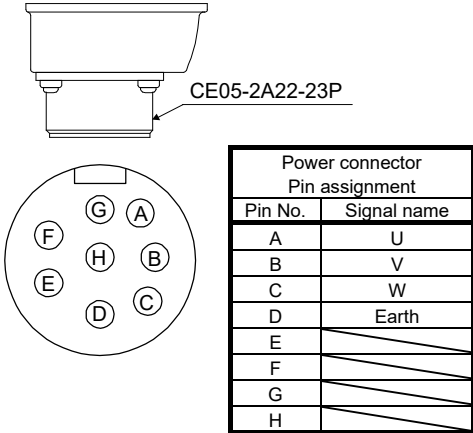
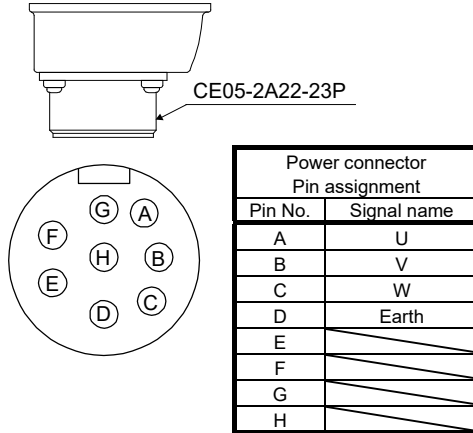
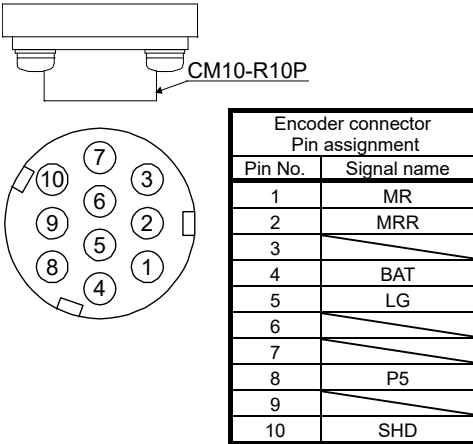
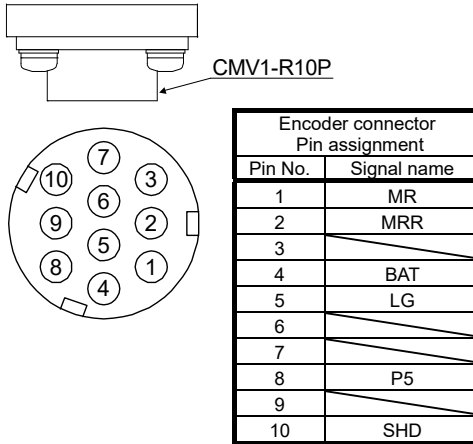
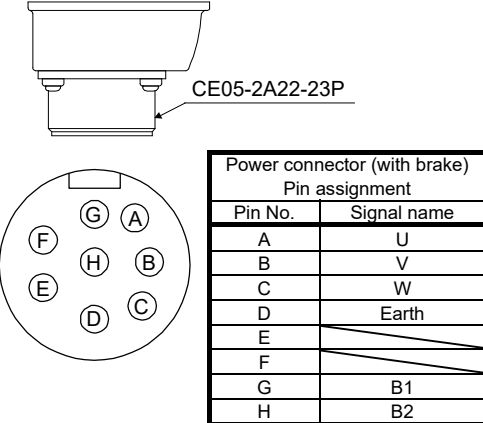
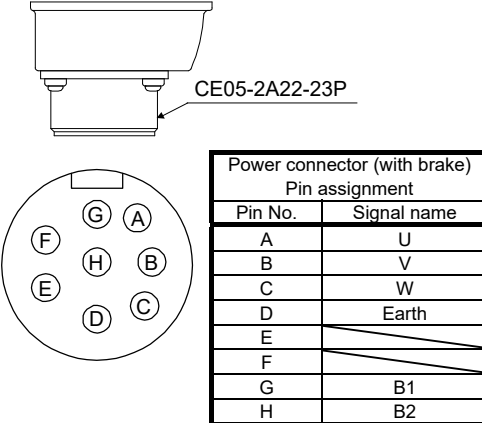
Servo amplifier series	MR-J3 series	MR-J4 series																																																
Servo motor series	HC-UP	HG-UR																																																
Target models	HC-UP72(B)/HC-UP152(B)	HG-UR72(B)/HG-UR152(B)																																																
Motor appearance	 <p>Power connector (With electromagnetic brake)</p> <p>Encoder connector</p>	 <p>Power connector (With electromagnetic brake)</p> <p>Encoder connector</p>																																																
Power connector	 <p>CE05-2A22-23P</p> <table border="1"> <thead> <tr> <th colspan="2">Power connector Pin assignment</th> </tr> <tr> <th>Pin No.</th> <th>Signal name</th> </tr> </thead> <tbody> <tr><td>A</td><td>U</td></tr> <tr><td>B</td><td>V</td></tr> <tr><td>C</td><td>W</td></tr> <tr><td>D</td><td>Earth</td></tr> <tr><td>E</td><td></td></tr> <tr><td>F</td><td></td></tr> <tr><td>G</td><td></td></tr> <tr><td>H</td><td></td></tr> </tbody> </table>	Power connector Pin assignment		Pin No.	Signal name	A	U	B	V	C	W	D	Earth	E		F		G		H		 <p>CE05-2A22-23P</p> <table border="1"> <thead> <tr> <th colspan="2">Power connector Pin assignment</th> </tr> <tr> <th>Pin No.</th> <th>Signal name</th> </tr> </thead> <tbody> <tr><td>A</td><td>U</td></tr> <tr><td>B</td><td>V</td></tr> <tr><td>C</td><td>W</td></tr> <tr><td>D</td><td>Earth</td></tr> <tr><td>E</td><td></td></tr> <tr><td>F</td><td></td></tr> <tr><td>G</td><td></td></tr> <tr><td>H</td><td></td></tr> </tbody> </table>	Power connector Pin assignment		Pin No.	Signal name	A	U	B	V	C	W	D	Earth	E		F		G		H									
Power connector Pin assignment																																																		
Pin No.	Signal name																																																	
A	U																																																	
B	V																																																	
C	W																																																	
D	Earth																																																	
E																																																		
F																																																		
G																																																		
H																																																		
Power connector Pin assignment																																																		
Pin No.	Signal name																																																	
A	U																																																	
B	V																																																	
C	W																																																	
D	Earth																																																	
E																																																		
F																																																		
G																																																		
H																																																		
Encoder connector (Note)	 <p>CM10-R10P</p> <table border="1"> <thead> <tr> <th colspan="2">Encoder connector Pin assignment</th> </tr> <tr> <th>Pin No.</th> <th>Signal name</th> </tr> </thead> <tbody> <tr><td>1</td><td>MR</td></tr> <tr><td>2</td><td>MRR</td></tr> <tr><td>3</td><td></td></tr> <tr><td>4</td><td>BAT</td></tr> <tr><td>5</td><td>LG</td></tr> <tr><td>6</td><td></td></tr> <tr><td>7</td><td></td></tr> <tr><td>8</td><td>P5</td></tr> <tr><td>9</td><td></td></tr> <tr><td>10</td><td>SHD</td></tr> </tbody> </table>	Encoder connector Pin assignment		Pin No.	Signal name	1	MR	2	MRR	3		4	BAT	5	LG	6		7		8	P5	9		10	SHD	 <p>CMV1-R10P</p> <table border="1"> <thead> <tr> <th colspan="2">Encoder connector Pin assignment</th> </tr> <tr> <th>Pin No.</th> <th>Signal name</th> </tr> </thead> <tbody> <tr><td>1</td><td>MR</td></tr> <tr><td>2</td><td>MRR</td></tr> <tr><td>3</td><td></td></tr> <tr><td>4</td><td>BAT</td></tr> <tr><td>5</td><td>LG</td></tr> <tr><td>6</td><td></td></tr> <tr><td>7</td><td></td></tr> <tr><td>8</td><td>P5</td></tr> <tr><td>9</td><td></td></tr> <tr><td>10</td><td>SHD</td></tr> </tbody> </table>	Encoder connector Pin assignment		Pin No.	Signal name	1	MR	2	MRR	3		4	BAT	5	LG	6		7		8	P5	9		10	SHD
Encoder connector Pin assignment																																																		
Pin No.	Signal name																																																	
1	MR																																																	
2	MRR																																																	
3																																																		
4	BAT																																																	
5	LG																																																	
6																																																		
7																																																		
8	P5																																																	
9																																																		
10	SHD																																																	
Encoder connector Pin assignment																																																		
Pin No.	Signal name																																																	
1	MR																																																	
2	MRR																																																	
3																																																		
4	BAT																																																	
5	LG																																																	
6																																																		
7																																																		
8	P5																																																	
9																																																		
10	SHD																																																	
Electromagnetic brake connector (Power connector)	 <p>CE05-2A22-23P</p> <table border="1"> <thead> <tr> <th colspan="2">Power connector (with brake) Pin assignment</th> </tr> <tr> <th>Pin No.</th> <th>Signal name</th> </tr> </thead> <tbody> <tr><td>A</td><td>U</td></tr> <tr><td>B</td><td>V</td></tr> <tr><td>C</td><td>W</td></tr> <tr><td>D</td><td>Earth</td></tr> <tr><td>E</td><td></td></tr> <tr><td>F</td><td></td></tr> <tr><td>G</td><td>B1</td></tr> <tr><td>H</td><td>B2</td></tr> </tbody> </table>	Power connector (with brake) Pin assignment		Pin No.	Signal name	A	U	B	V	C	W	D	Earth	E		F		G	B1	H	B2	 <p>CE05-2A22-23P</p> <table border="1"> <thead> <tr> <th colspan="2">Power connector (with brake) Pin assignment</th> </tr> <tr> <th>Pin No.</th> <th>Signal name</th> </tr> </thead> <tbody> <tr><td>A</td><td>U</td></tr> <tr><td>B</td><td>V</td></tr> <tr><td>C</td><td>W</td></tr> <tr><td>D</td><td>Earth</td></tr> <tr><td>E</td><td></td></tr> <tr><td>F</td><td></td></tr> <tr><td>G</td><td>B1</td></tr> <tr><td>H</td><td>B2</td></tr> </tbody> </table>	Power connector (with brake) Pin assignment		Pin No.	Signal name	A	U	B	V	C	W	D	Earth	E		F		G	B1	H	B2								
Power connector (with brake) Pin assignment																																																		
Pin No.	Signal name																																																	
A	U																																																	
B	V																																																	
C	W																																																	
D	Earth																																																	
E																																																		
F																																																		
G	B1																																																	
H	B2																																																	
Power connector (with brake) Pin assignment																																																		
Pin No.	Signal name																																																	
A	U																																																	
B	V																																																	
C	W																																																	
D	Earth																																																	
E																																																		
F																																																		
G	B1																																																	
H	B2																																																	

Note. Although the encoder connector type differs, it can be wired with the existing cables because the connector specifications have compatibility in wiring.

Part 9: Review on Replacement of Motor

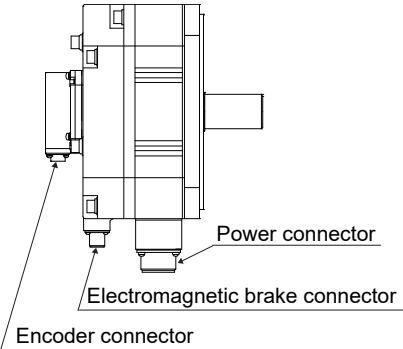
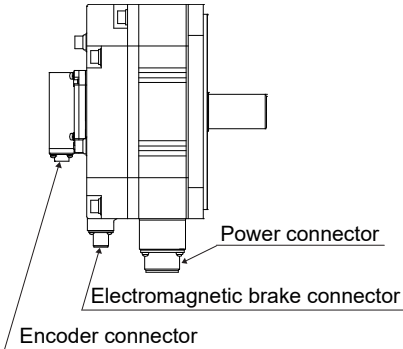
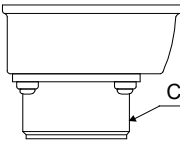
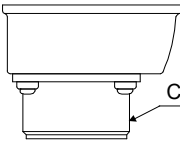
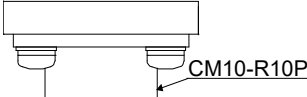
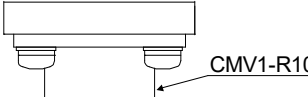
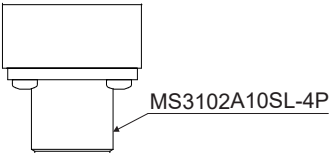
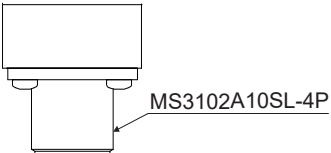
Servo amplifier series	MR-J3 series	MR-J4 series																																																
Servo motor series	HC-UP	HG-UR																																																
Target models	HC-UP202(B) to HC-UP502(B)	HG-UR202(B) to HG-UR502(B)																																																
Motor appearance																																																		
Power connector	 <table border="1" data-bbox="663 869 911 1133"> <thead> <tr> <th colspan="2">Power connector Pin assignment</th> </tr> <tr> <th>Pin No.</th> <th>Signal name</th> </tr> </thead> <tbody> <tr><td>A</td><td>U</td></tr> <tr><td>B</td><td>V</td></tr> <tr><td>C</td><td>W</td></tr> <tr><td>D</td><td>Earth</td></tr> <tr><td>E</td><td></td></tr> <tr><td>F</td><td></td></tr> <tr><td>G</td><td></td></tr> </tbody> </table>	Power connector Pin assignment		Pin No.	Signal name	A	U	B	V	C	W	D	Earth	E		F		G		 <table border="1" data-bbox="1182 869 1430 1133"> <thead> <tr> <th colspan="2">Power connector Pin assignment</th> </tr> <tr> <th>Pin No.</th> <th>Signal name</th> </tr> </thead> <tbody> <tr><td>A</td><td>U</td></tr> <tr><td>B</td><td>V</td></tr> <tr><td>C</td><td>W</td></tr> <tr><td>D</td><td>Earth</td></tr> <tr><td>E</td><td></td></tr> <tr><td>F</td><td></td></tr> <tr><td>G</td><td></td></tr> </tbody> </table>	Power connector Pin assignment		Pin No.	Signal name	A	U	B	V	C	W	D	Earth	E		F		G													
Power connector Pin assignment																																																		
Pin No.	Signal name																																																	
A	U																																																	
B	V																																																	
C	W																																																	
D	Earth																																																	
E																																																		
F																																																		
G																																																		
Power connector Pin assignment																																																		
Pin No.	Signal name																																																	
A	U																																																	
B	V																																																	
C	W																																																	
D	Earth																																																	
E																																																		
F																																																		
G																																																		
Encoder connector (Note)	 <table border="1" data-bbox="663 1267 911 1599"> <thead> <tr> <th colspan="2">Encoder connector Pin assignment</th> </tr> <tr> <th>Pin No.</th> <th>Signal name</th> </tr> </thead> <tbody> <tr><td>1</td><td>MR</td></tr> <tr><td>2</td><td>MRR</td></tr> <tr><td>3</td><td></td></tr> <tr><td>4</td><td>BAT</td></tr> <tr><td>5</td><td>LG</td></tr> <tr><td>6</td><td></td></tr> <tr><td>7</td><td></td></tr> <tr><td>8</td><td>P5</td></tr> <tr><td>9</td><td></td></tr> <tr><td>10</td><td>SHD</td></tr> </tbody> </table>	Encoder connector Pin assignment		Pin No.	Signal name	1	MR	2	MRR	3		4	BAT	5	LG	6		7		8	P5	9		10	SHD	 <table border="1" data-bbox="1182 1267 1430 1599"> <thead> <tr> <th colspan="2">Encoder connector Pin assignment</th> </tr> <tr> <th>Pin No.</th> <th>Signal name</th> </tr> </thead> <tbody> <tr><td>1</td><td>MR</td></tr> <tr><td>2</td><td>MRR</td></tr> <tr><td>3</td><td></td></tr> <tr><td>4</td><td>BAT</td></tr> <tr><td>5</td><td>LG</td></tr> <tr><td>6</td><td></td></tr> <tr><td>7</td><td></td></tr> <tr><td>8</td><td>P5</td></tr> <tr><td>9</td><td></td></tr> <tr><td>10</td><td>SHD</td></tr> </tbody> </table>	Encoder connector Pin assignment		Pin No.	Signal name	1	MR	2	MRR	3		4	BAT	5	LG	6		7		8	P5	9		10	SHD
Encoder connector Pin assignment																																																		
Pin No.	Signal name																																																	
1	MR																																																	
2	MRR																																																	
3																																																		
4	BAT																																																	
5	LG																																																	
6																																																		
7																																																		
8	P5																																																	
9																																																		
10	SHD																																																	
Encoder connector Pin assignment																																																		
Pin No.	Signal name																																																	
1	MR																																																	
2	MRR																																																	
3																																																		
4	BAT																																																	
5	LG																																																	
6																																																		
7																																																		
8	P5																																																	
9																																																		
10	SHD																																																	
Electromagnetic brake connector (Note)	 <table border="1" data-bbox="632 1783 890 1912"> <thead> <tr> <th colspan="2">Electromagnetic brake connector Pin assignment</th> </tr> <tr> <th>Pin No.</th> <th>Signal name</th> </tr> </thead> <tbody> <tr><td>A</td><td>B1</td></tr> <tr><td>B</td><td>B2</td></tr> </tbody> </table>	Electromagnetic brake connector Pin assignment		Pin No.	Signal name	A	B1	B	B2	 <table border="1" data-bbox="1150 1783 1409 1912"> <thead> <tr> <th colspan="2">Electromagnetic brake connector Pin assignment</th> </tr> <tr> <th>Pin No.</th> <th>Signal name</th> </tr> </thead> <tbody> <tr><td>A</td><td>B1</td></tr> <tr><td>B</td><td>B2</td></tr> </tbody> </table>	Electromagnetic brake connector Pin assignment		Pin No.	Signal name	A	B1	B	B2																																
Electromagnetic brake connector Pin assignment																																																		
Pin No.	Signal name																																																	
A	B1																																																	
B	B2																																																	
Electromagnetic brake connector Pin assignment																																																		
Pin No.	Signal name																																																	
A	B1																																																	
B	B2																																																	

Note. Although the encoder connector type differs, it can be wired with the existing cables because the connector specifications have compatibility in wiring.

Part 9: Review on Replacement of Motor

(6) HF-JP series

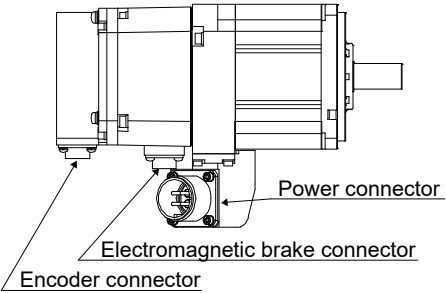
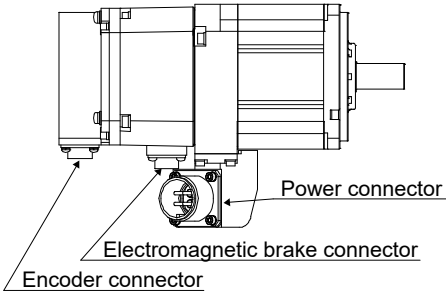
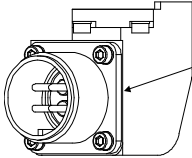
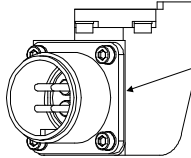
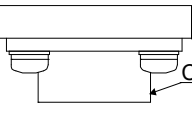
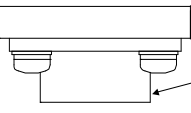
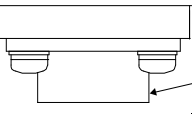
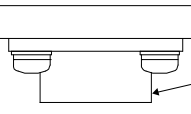
Servo amplifier series	MR-J3 series	MR-J4 series																																																
Servo motor series	HF-JP	HG-JR																																																
Target models	HF-JP53(4)(B) to HF-JP203(4)(B)	HG-JR53(4)(B) to HG-JR203(4)(B)																																																
Motor appearance																																																		
Power connector	 <table border="1"> <thead> <tr> <th colspan="2">Power connector Pin assignment</th> </tr> <tr> <th>Pin No.</th> <th>Signal name</th> </tr> </thead> <tbody> <tr> <td>A</td> <td>U</td> </tr> <tr> <td>B</td> <td>V</td> </tr> <tr> <td>C</td> <td>W</td> </tr> <tr> <td>D</td> <td>Earth</td> </tr> </tbody> </table>	Power connector Pin assignment		Pin No.	Signal name	A	U	B	V	C	W	D	Earth	 <table border="1"> <thead> <tr> <th colspan="2">Power connector Pin assignment</th> </tr> <tr> <th>Pin No.</th> <th>Signal name</th> </tr> </thead> <tbody> <tr> <td>A</td> <td>U</td> </tr> <tr> <td>B</td> <td>V</td> </tr> <tr> <td>C</td> <td>W</td> </tr> <tr> <td>D</td> <td>Earth</td> </tr> </tbody> </table>	Power connector Pin assignment		Pin No.	Signal name	A	U	B	V	C	W	D	Earth																								
Power connector Pin assignment																																																		
Pin No.	Signal name																																																	
A	U																																																	
B	V																																																	
C	W																																																	
D	Earth																																																	
Power connector Pin assignment																																																		
Pin No.	Signal name																																																	
A	U																																																	
B	V																																																	
C	W																																																	
D	Earth																																																	
Encoder connector (Note)	 <table border="1"> <thead> <tr> <th colspan="2">Encoder connector Pin assignment</th> </tr> <tr> <th>Pin No.</th> <th>Signal name</th> </tr> </thead> <tbody> <tr> <td>1</td> <td>MR</td> </tr> <tr> <td>2</td> <td>MRR</td> </tr> <tr> <td>3</td> <td></td> </tr> <tr> <td>4</td> <td>BAT</td> </tr> <tr> <td>5</td> <td>LG</td> </tr> <tr> <td>6</td> <td></td> </tr> <tr> <td>7</td> <td></td> </tr> <tr> <td>8</td> <td>P5</td> </tr> <tr> <td>9</td> <td></td> </tr> <tr> <td>10</td> <td>SHD</td> </tr> </tbody> </table>	Encoder connector Pin assignment		Pin No.	Signal name	1	MR	2	MRR	3		4	BAT	5	LG	6		7		8	P5	9		10	SHD	 <table border="1"> <thead> <tr> <th colspan="2">Encoder connector Pin assignment</th> </tr> <tr> <th>Pin No.</th> <th>Signal name</th> </tr> </thead> <tbody> <tr> <td>1</td> <td>MR</td> </tr> <tr> <td>2</td> <td>MRR</td> </tr> <tr> <td>3</td> <td></td> </tr> <tr> <td>4</td> <td>BAT</td> </tr> <tr> <td>5</td> <td>LG</td> </tr> <tr> <td>6</td> <td></td> </tr> <tr> <td>7</td> <td></td> </tr> <tr> <td>8</td> <td>P5</td> </tr> <tr> <td>9</td> <td></td> </tr> <tr> <td>10</td> <td>SHD</td> </tr> </tbody> </table>	Encoder connector Pin assignment		Pin No.	Signal name	1	MR	2	MRR	3		4	BAT	5	LG	6		7		8	P5	9		10	SHD
Encoder connector Pin assignment																																																		
Pin No.	Signal name																																																	
1	MR																																																	
2	MRR																																																	
3																																																		
4	BAT																																																	
5	LG																																																	
6																																																		
7																																																		
8	P5																																																	
9																																																		
10	SHD																																																	
Encoder connector Pin assignment																																																		
Pin No.	Signal name																																																	
1	MR																																																	
2	MRR																																																	
3																																																		
4	BAT																																																	
5	LG																																																	
6																																																		
7																																																		
8	P5																																																	
9																																																		
10	SHD																																																	
Electromagnetic brake connector (Note)	 <table border="1"> <thead> <tr> <th colspan="2">Electromagnetic brake connector Pin assignment</th> </tr> <tr> <th>Pin No.</th> <th>Signal name</th> </tr> </thead> <tbody> <tr> <td>1</td> <td>B1</td> </tr> <tr> <td>2</td> <td>B2</td> </tr> </tbody> </table>	Electromagnetic brake connector Pin assignment		Pin No.	Signal name	1	B1	2	B2	 <table border="1"> <thead> <tr> <th colspan="2">Electromagnetic brake connector Pin assignment</th> </tr> <tr> <th>Pin No.</th> <th>Signal name</th> </tr> </thead> <tbody> <tr> <td>1</td> <td>B1</td> </tr> <tr> <td>2</td> <td>B2</td> </tr> </tbody> </table>	Electromagnetic brake connector Pin assignment		Pin No.	Signal name	1	B1	2	B2																																
Electromagnetic brake connector Pin assignment																																																		
Pin No.	Signal name																																																	
1	B1																																																	
2	B2																																																	
Electromagnetic brake connector Pin assignment																																																		
Pin No.	Signal name																																																	
1	B1																																																	
2	B2																																																	

Note. Although the types of encoder and electromagnetic brake connector differ, they can be wired with the existing cables because the connector specifications have compatibility in wiring.

Part 9: Review on Replacement of Motor

Servo amplifier series	MR-J3 series	MR-J4 series																																																
Servo motor series	HF-JP	HG-JR																																																
Target models	HF-JP353(B)/HF-JP503(B)	HG-JR353(B)/HG-JR503(B)																																																
Motor appearance																																																		
Power connector	<table border="1"> <thead> <tr> <th colspan="2">Power connector Pin assignment</th> </tr> <tr> <th>Pin No.</th> <th>Signal name</th> </tr> </thead> <tbody> <tr> <td>A</td> <td>U</td> </tr> <tr> <td>B</td> <td>V</td> </tr> <tr> <td>C</td> <td>W</td> </tr> <tr> <td>D</td> <td>Earth</td> </tr> </tbody> </table>	Power connector Pin assignment		Pin No.	Signal name	A	U	B	V	C	W	D	Earth	<table border="1"> <thead> <tr> <th colspan="2">Power connector Pin assignment</th> </tr> <tr> <th>Pin No.</th> <th>Signal name</th> </tr> </thead> <tbody> <tr> <td>A</td> <td>U</td> </tr> <tr> <td>B</td> <td>V</td> </tr> <tr> <td>C</td> <td>W</td> </tr> <tr> <td>D</td> <td>Earth</td> </tr> </tbody> </table>	Power connector Pin assignment		Pin No.	Signal name	A	U	B	V	C	W	D	Earth																								
Power connector Pin assignment																																																		
Pin No.	Signal name																																																	
A	U																																																	
B	V																																																	
C	W																																																	
D	Earth																																																	
Power connector Pin assignment																																																		
Pin No.	Signal name																																																	
A	U																																																	
B	V																																																	
C	W																																																	
D	Earth																																																	
Encoder connector (Note)	<table border="1"> <thead> <tr> <th colspan="2">Encoder connector Pin assignment</th> </tr> <tr> <th>Pin No.</th> <th>Signal name</th> </tr> </thead> <tbody> <tr> <td>1</td> <td>MR</td> </tr> <tr> <td>2</td> <td>MRR</td> </tr> <tr> <td>3</td> <td></td> </tr> <tr> <td>4</td> <td>BAT</td> </tr> <tr> <td>5</td> <td>LG</td> </tr> <tr> <td>6</td> <td></td> </tr> <tr> <td>7</td> <td></td> </tr> <tr> <td>8</td> <td>P5</td> </tr> <tr> <td>9</td> <td></td> </tr> <tr> <td>10</td> <td>SHD</td> </tr> </tbody> </table>	Encoder connector Pin assignment		Pin No.	Signal name	1	MR	2	MRR	3		4	BAT	5	LG	6		7		8	P5	9		10	SHD	<table border="1"> <thead> <tr> <th colspan="2">Encoder connector Pin assignment</th> </tr> <tr> <th>Pin No.</th> <th>Signal name</th> </tr> </thead> <tbody> <tr> <td>1</td> <td>MR</td> </tr> <tr> <td>2</td> <td>MRR</td> </tr> <tr> <td>3</td> <td></td> </tr> <tr> <td>4</td> <td>BAT</td> </tr> <tr> <td>5</td> <td>LG</td> </tr> <tr> <td>6</td> <td></td> </tr> <tr> <td>7</td> <td></td> </tr> <tr> <td>8</td> <td>P5</td> </tr> <tr> <td>9</td> <td></td> </tr> <tr> <td>10</td> <td>SHD</td> </tr> </tbody> </table>	Encoder connector Pin assignment		Pin No.	Signal name	1	MR	2	MRR	3		4	BAT	5	LG	6		7		8	P5	9		10	SHD
Encoder connector Pin assignment																																																		
Pin No.	Signal name																																																	
1	MR																																																	
2	MRR																																																	
3																																																		
4	BAT																																																	
5	LG																																																	
6																																																		
7																																																		
8	P5																																																	
9																																																		
10	SHD																																																	
Encoder connector Pin assignment																																																		
Pin No.	Signal name																																																	
1	MR																																																	
2	MRR																																																	
3																																																		
4	BAT																																																	
5	LG																																																	
6																																																		
7																																																		
8	P5																																																	
9																																																		
10	SHD																																																	
Electromagnetic brake connector (Note)	<table border="1"> <thead> <tr> <th colspan="2">Electromagnetic brake connector Pin assignment</th> </tr> <tr> <th>Pin No.</th> <th>Signal name</th> </tr> </thead> <tbody> <tr> <td>1</td> <td>B1</td> </tr> <tr> <td>2</td> <td>B2</td> </tr> </tbody> </table>	Electromagnetic brake connector Pin assignment		Pin No.	Signal name	1	B1	2	B2	<table border="1"> <thead> <tr> <th colspan="2">Electromagnetic brake connector Pin assignment</th> </tr> <tr> <th>Pin No.</th> <th>Signal name</th> </tr> </thead> <tbody> <tr> <td>1</td> <td>B1</td> </tr> <tr> <td>2</td> <td>B2</td> </tr> </tbody> </table>	Electromagnetic brake connector Pin assignment		Pin No.	Signal name	1	B1	2	B2																																
Electromagnetic brake connector Pin assignment																																																		
Pin No.	Signal name																																																	
1	B1																																																	
2	B2																																																	
Electromagnetic brake connector Pin assignment																																																		
Pin No.	Signal name																																																	
1	B1																																																	
2	B2																																																	

Note. Although the types of encoder and electromagnetic brake connector differ, they can be wired with the existing cables because the connector specifications have compatibility in wiring.

Part 9: Review on Replacement of Motor

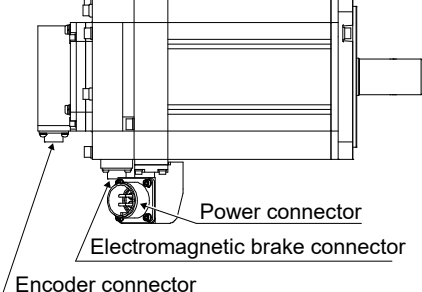
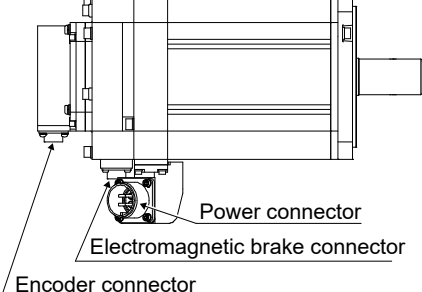
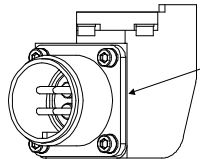
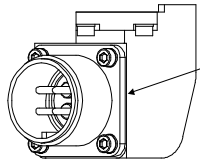
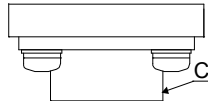
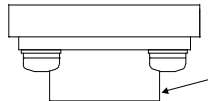
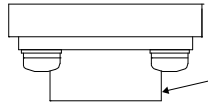
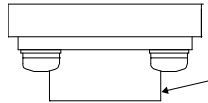
Servo amplifier series	MR-J3 series	MR-J4 series																																																
Servo motor series	HF-JP	HG-JR																																																
Target models	HF-JP3534(B)/HF-JP5034(B)	HG-JR3534(B)/HG-JR5034(B)																																																
Motor appearance																																																		
Power connector	 <table border="1" data-bbox="662 828 909 1019"> <thead> <tr> <th colspan="2">Power connector Pin assignment</th> </tr> <tr> <th>Pin No.</th> <th>Signal name</th> </tr> </thead> <tbody> <tr> <td>A</td> <td>U</td> </tr> <tr> <td>B</td> <td>V</td> </tr> <tr> <td>C</td> <td>W</td> </tr> <tr> <td>D</td> <td>Earth</td> </tr> </tbody> </table>	Power connector Pin assignment		Pin No.	Signal name	A	U	B	V	C	W	D	Earth	 <table border="1" data-bbox="1181 828 1428 1019"> <thead> <tr> <th colspan="2">Power connector Pin assignment</th> </tr> <tr> <th>Pin No.</th> <th>Signal name</th> </tr> </thead> <tbody> <tr> <td>A</td> <td>U</td> </tr> <tr> <td>B</td> <td>V</td> </tr> <tr> <td>C</td> <td>W</td> </tr> <tr> <td>D</td> <td>Earth</td> </tr> </tbody> </table>	Power connector Pin assignment		Pin No.	Signal name	A	U	B	V	C	W	D	Earth																								
Power connector Pin assignment																																																		
Pin No.	Signal name																																																	
A	U																																																	
B	V																																																	
C	W																																																	
D	Earth																																																	
Power connector Pin assignment																																																		
Pin No.	Signal name																																																	
A	U																																																	
B	V																																																	
C	W																																																	
D	Earth																																																	
Encoder connector (Note)	 <table border="1" data-bbox="662 1187 909 1523"> <thead> <tr> <th colspan="2">Encoder connector Pin assignment</th> </tr> <tr> <th>Pin No.</th> <th>Signal name</th> </tr> </thead> <tbody> <tr> <td>1</td> <td>MR</td> </tr> <tr> <td>2</td> <td>MRR</td> </tr> <tr> <td>3</td> <td></td> </tr> <tr> <td>4</td> <td>BAT</td> </tr> <tr> <td>5</td> <td>LG</td> </tr> <tr> <td>6</td> <td></td> </tr> <tr> <td>7</td> <td></td> </tr> <tr> <td>8</td> <td>P5</td> </tr> <tr> <td>9</td> <td></td> </tr> <tr> <td>10</td> <td>SHD</td> </tr> </tbody> </table>	Encoder connector Pin assignment		Pin No.	Signal name	1	MR	2	MRR	3		4	BAT	5	LG	6		7		8	P5	9		10	SHD	 <table border="1" data-bbox="1181 1187 1428 1523"> <thead> <tr> <th colspan="2">Encoder connector Pin assignment</th> </tr> <tr> <th>Pin No.</th> <th>Signal name</th> </tr> </thead> <tbody> <tr> <td>1</td> <td>MR</td> </tr> <tr> <td>2</td> <td>MRR</td> </tr> <tr> <td>3</td> <td></td> </tr> <tr> <td>4</td> <td>BAT</td> </tr> <tr> <td>5</td> <td>LG</td> </tr> <tr> <td>6</td> <td></td> </tr> <tr> <td>7</td> <td></td> </tr> <tr> <td>8</td> <td>P5</td> </tr> <tr> <td>9</td> <td></td> </tr> <tr> <td>10</td> <td>SHD</td> </tr> </tbody> </table>	Encoder connector Pin assignment		Pin No.	Signal name	1	MR	2	MRR	3		4	BAT	5	LG	6		7		8	P5	9		10	SHD
Encoder connector Pin assignment																																																		
Pin No.	Signal name																																																	
1	MR																																																	
2	MRR																																																	
3																																																		
4	BAT																																																	
5	LG																																																	
6																																																		
7																																																		
8	P5																																																	
9																																																		
10	SHD																																																	
Encoder connector Pin assignment																																																		
Pin No.	Signal name																																																	
1	MR																																																	
2	MRR																																																	
3																																																		
4	BAT																																																	
5	LG																																																	
6																																																		
7																																																		
8	P5																																																	
9																																																		
10	SHD																																																	
Electromagnetic brake connector (Note)	 <table border="1" data-bbox="630 1668 901 1803"> <thead> <tr> <th colspan="2">Electromagnetic brake connector Pin assignment</th> </tr> <tr> <th>Pin No.</th> <th>Signal name</th> </tr> </thead> <tbody> <tr> <td>1</td> <td>B1</td> </tr> <tr> <td>2</td> <td>B2</td> </tr> </tbody> </table>	Electromagnetic brake connector Pin assignment		Pin No.	Signal name	1	B1	2	B2	 <table border="1" data-bbox="1149 1668 1420 1803"> <thead> <tr> <th colspan="2">Electromagnetic brake connector Pin assignment</th> </tr> <tr> <th>Pin No.</th> <th>Signal name</th> </tr> </thead> <tbody> <tr> <td>1</td> <td>B1</td> </tr> <tr> <td>2</td> <td>B2</td> </tr> </tbody> </table>	Electromagnetic brake connector Pin assignment		Pin No.	Signal name	1	B1	2	B2																																
Electromagnetic brake connector Pin assignment																																																		
Pin No.	Signal name																																																	
1	B1																																																	
2	B2																																																	
Electromagnetic brake connector Pin assignment																																																		
Pin No.	Signal name																																																	
1	B1																																																	
2	B2																																																	

Note. Although the types of encoder and electromagnetic brake connector differ, they can be wired with the existing cables because the connector specifications have compatibility in wiring.

Part 9: Review on Replacement of Motor

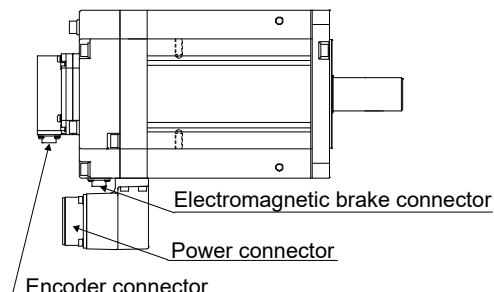
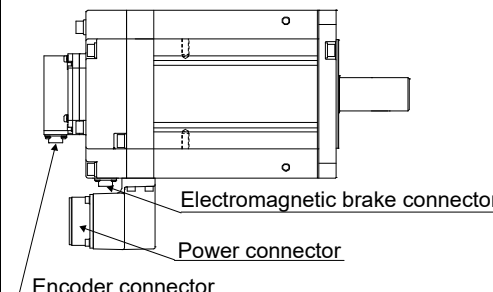
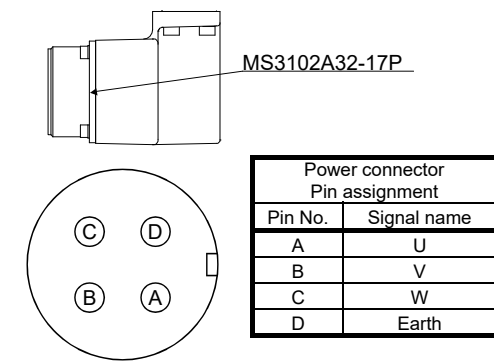
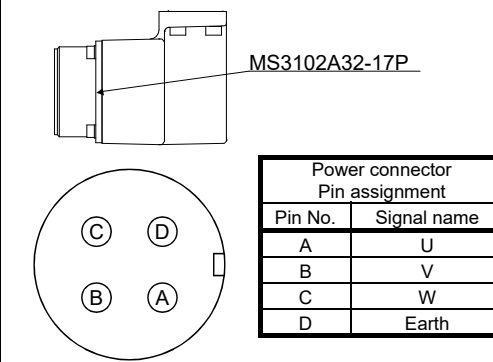
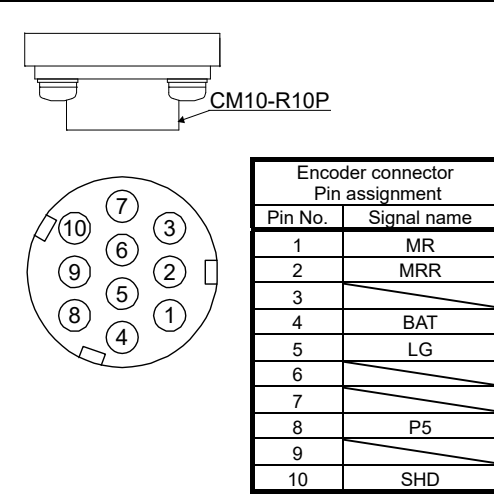
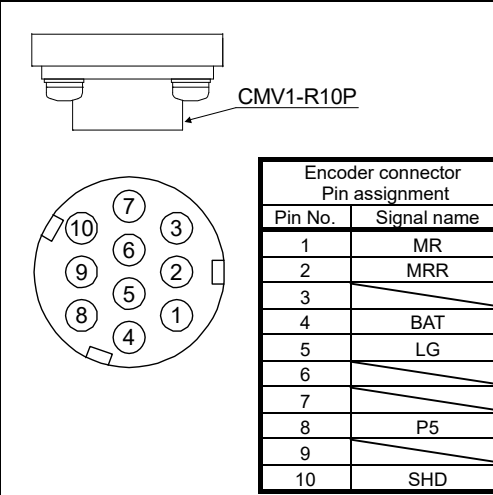
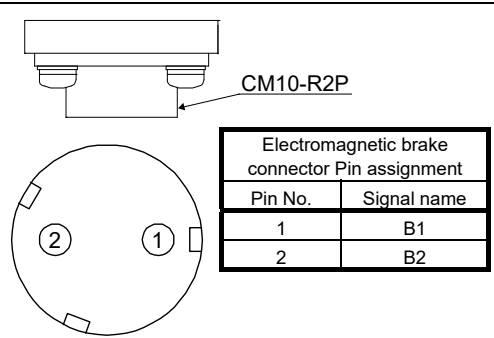
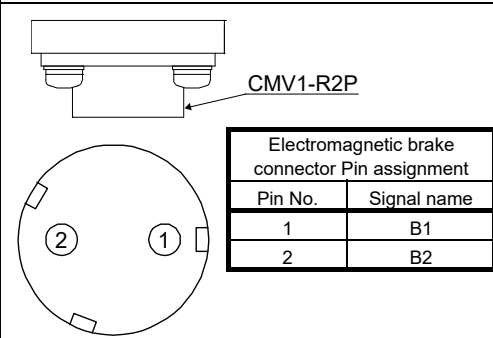
Servo amplifier series	MR-J3 series	MR-J4 series																																																
Servo motor series	HF-JP	HG-JR																																																
Target models	HF-JP703(4)(B)/HF-JP903(4)(B)	HG-JR703(4)(B)/HG-JR903(4)(B)																																																
Motor appearance																																																		
Power connector	 <table border="1" data-bbox="662 795 909 985"> <thead> <tr> <th colspan="2">Power connector Pin assignment</th> </tr> <tr> <th>Pin No.</th> <th>Signal name</th> </tr> </thead> <tbody> <tr> <td>A</td> <td>U</td> </tr> <tr> <td>B</td> <td>V</td> </tr> <tr> <td>C</td> <td>W</td> </tr> <tr> <td>D</td> <td>Earth</td> </tr> </tbody> </table>	Power connector Pin assignment		Pin No.	Signal name	A	U	B	V	C	W	D	Earth	 <table border="1" data-bbox="1173 795 1420 985"> <thead> <tr> <th colspan="2">Power connector Pin assignment</th> </tr> <tr> <th>Pin No.</th> <th>Signal name</th> </tr> </thead> <tbody> <tr> <td>A</td> <td>U</td> </tr> <tr> <td>B</td> <td>V</td> </tr> <tr> <td>C</td> <td>W</td> </tr> <tr> <td>D</td> <td>Earth</td> </tr> </tbody> </table>	Power connector Pin assignment		Pin No.	Signal name	A	U	B	V	C	W	D	Earth																								
Power connector Pin assignment																																																		
Pin No.	Signal name																																																	
A	U																																																	
B	V																																																	
C	W																																																	
D	Earth																																																	
Power connector Pin assignment																																																		
Pin No.	Signal name																																																	
A	U																																																	
B	V																																																	
C	W																																																	
D	Earth																																																	
Encoder connector (Note)	 <table border="1" data-bbox="662 1176 909 1523"> <thead> <tr> <th colspan="2">Encoder connector Pin assignment</th> </tr> <tr> <th>Pin No.</th> <th>Signal name</th> </tr> </thead> <tbody> <tr> <td>1</td> <td>MR</td> </tr> <tr> <td>2</td> <td>MRR</td> </tr> <tr> <td>3</td> <td></td> </tr> <tr> <td>4</td> <td>BAT</td> </tr> <tr> <td>5</td> <td>LG</td> </tr> <tr> <td>6</td> <td></td> </tr> <tr> <td>7</td> <td></td> </tr> <tr> <td>8</td> <td>P5</td> </tr> <tr> <td>9</td> <td></td> </tr> <tr> <td>10</td> <td>SHD</td> </tr> </tbody> </table>	Encoder connector Pin assignment		Pin No.	Signal name	1	MR	2	MRR	3		4	BAT	5	LG	6		7		8	P5	9		10	SHD	 <table border="1" data-bbox="1173 1176 1420 1523"> <thead> <tr> <th colspan="2">Encoder connector Pin assignment</th> </tr> <tr> <th>Pin No.</th> <th>Signal name</th> </tr> </thead> <tbody> <tr> <td>1</td> <td>MR</td> </tr> <tr> <td>2</td> <td>MRR</td> </tr> <tr> <td>3</td> <td></td> </tr> <tr> <td>4</td> <td>BAT</td> </tr> <tr> <td>5</td> <td>LG</td> </tr> <tr> <td>6</td> <td></td> </tr> <tr> <td>7</td> <td></td> </tr> <tr> <td>8</td> <td>P5</td> </tr> <tr> <td>9</td> <td></td> </tr> <tr> <td>10</td> <td>SHD</td> </tr> </tbody> </table>	Encoder connector Pin assignment		Pin No.	Signal name	1	MR	2	MRR	3		4	BAT	5	LG	6		7		8	P5	9		10	SHD
Encoder connector Pin assignment																																																		
Pin No.	Signal name																																																	
1	MR																																																	
2	MRR																																																	
3																																																		
4	BAT																																																	
5	LG																																																	
6																																																		
7																																																		
8	P5																																																	
9																																																		
10	SHD																																																	
Encoder connector Pin assignment																																																		
Pin No.	Signal name																																																	
1	MR																																																	
2	MRR																																																	
3																																																		
4	BAT																																																	
5	LG																																																	
6																																																		
7																																																		
8	P5																																																	
9																																																		
10	SHD																																																	
Electromagnetic brake connector (Note)	 <table border="1" data-bbox="630 1668 901 1814"> <thead> <tr> <th colspan="2">Electromagnetic brake connector Pin assignment</th> </tr> <tr> <th>Pin No.</th> <th>Signal name</th> </tr> </thead> <tbody> <tr> <td>1</td> <td>B1</td> </tr> <tr> <td>2</td> <td>B2</td> </tr> </tbody> </table>	Electromagnetic brake connector Pin assignment		Pin No.	Signal name	1	B1	2	B2	 <table border="1" data-bbox="1141 1668 1412 1814"> <thead> <tr> <th colspan="2">Electromagnetic brake connector Pin assignment</th> </tr> <tr> <th>Pin No.</th> <th>Signal name</th> </tr> </thead> <tbody> <tr> <td>1</td> <td>B1</td> </tr> <tr> <td>2</td> <td>B2</td> </tr> </tbody> </table>	Electromagnetic brake connector Pin assignment		Pin No.	Signal name	1	B1	2	B2																																
Electromagnetic brake connector Pin assignment																																																		
Pin No.	Signal name																																																	
1	B1																																																	
2	B2																																																	
Electromagnetic brake connector Pin assignment																																																		
Pin No.	Signal name																																																	
1	B1																																																	
2	B2																																																	

Note. Although the types of encoder and electromagnetic brake connector differ, they can be wired with the existing cables because the connector specifications have compatibility in wiring.

Part 9: Review on Replacement of Motor

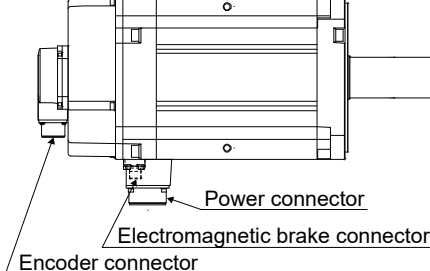
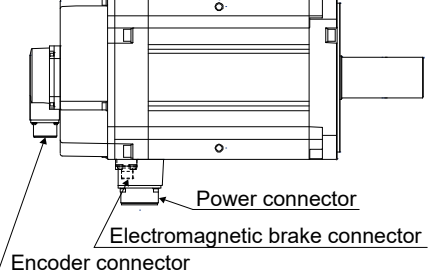
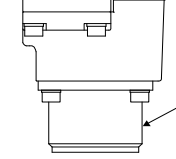
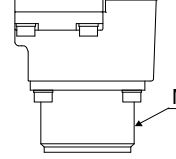
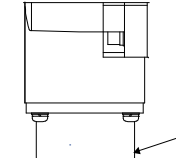
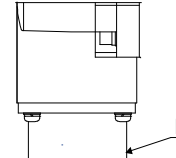
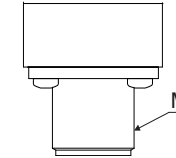
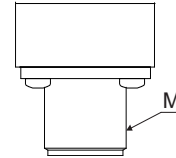
Servo amplifier series	MR-J3 series	MR-J4 series																																																																												
Servo motor series	HF-JP	HG-JR																																																																												
Target models	HF-JP11K1M(4)(B)/HF-JP15K1M(4)(B)	HG-JR11K1M(4)(B)/HG-JR15K1M(4)(B)																																																																												
Motor appearance																																																																														
Power connector	 <table border="1" data-bbox="662 795 909 974"> <thead> <tr> <th colspan="2">Power connector Pin assignment</th> </tr> <tr> <th>Pin No.</th> <th>Signal name</th> </tr> </thead> <tbody> <tr> <td>A</td> <td>U</td> </tr> <tr> <td>B</td> <td>V</td> </tr> <tr> <td>C</td> <td>W</td> </tr> <tr> <td>D</td> <td>Earth</td> </tr> </tbody> </table>	Power connector Pin assignment		Pin No.	Signal name	A	U	B	V	C	W	D	Earth	 <table border="1" data-bbox="1181 795 1428 974"> <thead> <tr> <th colspan="2">Power connector Pin assignment</th> </tr> <tr> <th>Pin No.</th> <th>Signal name</th> </tr> </thead> <tbody> <tr> <td>A</td> <td>U</td> </tr> <tr> <td>B</td> <td>V</td> </tr> <tr> <td>C</td> <td>W</td> </tr> <tr> <td>D</td> <td>Earth</td> </tr> </tbody> </table>	Power connector Pin assignment		Pin No.	Signal name	A	U	B	V	C	W	D	Earth																																																				
Power connector Pin assignment																																																																														
Pin No.	Signal name																																																																													
A	U																																																																													
B	V																																																																													
C	W																																																																													
D	Earth																																																																													
Power connector Pin assignment																																																																														
Pin No.	Signal name																																																																													
A	U																																																																													
B	V																																																																													
C	W																																																																													
D	Earth																																																																													
Encoder connector	 <table border="1" data-bbox="662 1187 909 1657"> <thead> <tr> <th colspan="2">Encoder connector Pin assignment</th> </tr> <tr> <th>Pin No.</th> <th>Signal name</th> </tr> </thead> <tbody> <tr> <td>A</td> <td></td> </tr> <tr> <td>B</td> <td></td> </tr> <tr> <td>C</td> <td>MR</td> </tr> <tr> <td>D</td> <td>MRR</td> </tr> <tr> <td>E</td> <td></td> </tr> <tr> <td>F</td> <td>BAT</td> </tr> <tr> <td>G</td> <td>LG</td> </tr> <tr> <td>H</td> <td></td> </tr> <tr> <td>J</td> <td></td> </tr> <tr> <td>K</td> <td></td> </tr> <tr> <td>L</td> <td></td> </tr> <tr> <td>M</td> <td></td> </tr> <tr> <td>N</td> <td>SHD</td> </tr> <tr> <td>P</td> <td></td> </tr> <tr> <td>R</td> <td>LG</td> </tr> <tr> <td>S</td> <td>P5</td> </tr> <tr> <td>T</td> <td></td> </tr> </tbody> </table>	Encoder connector Pin assignment		Pin No.	Signal name	A		B		C	MR	D	MRR	E		F	BAT	G	LG	H		J		K		L		M		N	SHD	P		R	LG	S	P5	T		 <table border="1" data-bbox="1181 1187 1428 1657"> <thead> <tr> <th colspan="2">Encoder connector Pin assignment</th> </tr> <tr> <th>Pin No.</th> <th>Signal name</th> </tr> </thead> <tbody> <tr> <td>A</td> <td></td> </tr> <tr> <td>B</td> <td></td> </tr> <tr> <td>C</td> <td>MR</td> </tr> <tr> <td>D</td> <td>MRR</td> </tr> <tr> <td>E</td> <td></td> </tr> <tr> <td>F</td> <td>BAT</td> </tr> <tr> <td>G</td> <td>LG</td> </tr> <tr> <td>H</td> <td></td> </tr> <tr> <td>J</td> <td></td> </tr> <tr> <td>K</td> <td></td> </tr> <tr> <td>L</td> <td></td> </tr> <tr> <td>M</td> <td></td> </tr> <tr> <td>N</td> <td>SHD</td> </tr> <tr> <td>P</td> <td></td> </tr> <tr> <td>R</td> <td>LG</td> </tr> <tr> <td>S</td> <td>P5</td> </tr> <tr> <td>T</td> <td></td> </tr> </tbody> </table>	Encoder connector Pin assignment		Pin No.	Signal name	A		B		C	MR	D	MRR	E		F	BAT	G	LG	H		J		K		L		M		N	SHD	P		R	LG	S	P5	T	
Encoder connector Pin assignment																																																																														
Pin No.	Signal name																																																																													
A																																																																														
B																																																																														
C	MR																																																																													
D	MRR																																																																													
E																																																																														
F	BAT																																																																													
G	LG																																																																													
H																																																																														
J																																																																														
K																																																																														
L																																																																														
M																																																																														
N	SHD																																																																													
P																																																																														
R	LG																																																																													
S	P5																																																																													
T																																																																														
Encoder connector Pin assignment																																																																														
Pin No.	Signal name																																																																													
A																																																																														
B																																																																														
C	MR																																																																													
D	MRR																																																																													
E																																																																														
F	BAT																																																																													
G	LG																																																																													
H																																																																														
J																																																																														
K																																																																														
L																																																																														
M																																																																														
N	SHD																																																																													
P																																																																														
R	LG																																																																													
S	P5																																																																													
T																																																																														
Electromagnetic brake connector (Note)	 <table border="1" data-bbox="630 1836 885 1971"> <thead> <tr> <th colspan="2">Electromagnetic brake connector Pin assignment</th> </tr> <tr> <th>Pin No.</th> <th>Signal name</th> </tr> </thead> <tbody> <tr> <td>A</td> <td>B1</td> </tr> <tr> <td>B</td> <td>B2</td> </tr> </tbody> </table>	Electromagnetic brake connector Pin assignment		Pin No.	Signal name	A	B1	B	B2	 <table border="1" data-bbox="1149 1836 1404 1971"> <thead> <tr> <th colspan="2">Electromagnetic brake connector Pin assignment</th> </tr> <tr> <th>Pin No.</th> <th>Signal name</th> </tr> </thead> <tbody> <tr> <td>A</td> <td>B1</td> </tr> <tr> <td>B</td> <td>B2</td> </tr> </tbody> </table>	Electromagnetic brake connector Pin assignment		Pin No.	Signal name	A	B1	B	B2																																																												
Electromagnetic brake connector Pin assignment																																																																														
Pin No.	Signal name																																																																													
A	B1																																																																													
B	B2																																																																													
Electromagnetic brake connector Pin assignment																																																																														
Pin No.	Signal name																																																																													
A	B1																																																																													
B	B2																																																																													

Note. Although the types of encoder and electromagnetic brake connector differ, they can be wired with the existing cables because the connector specifications have compatibility in wiring.

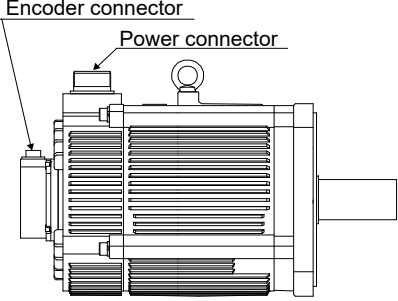
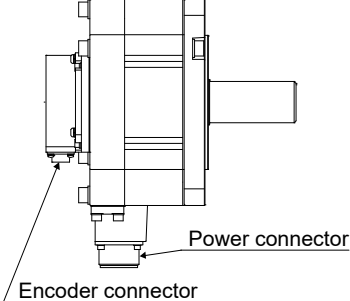
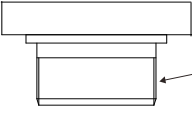
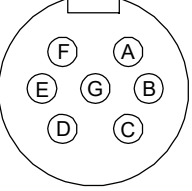
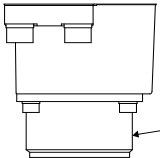
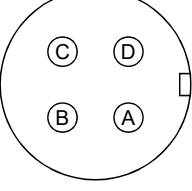
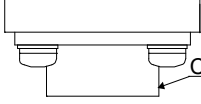
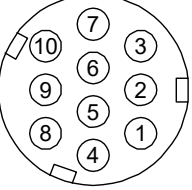
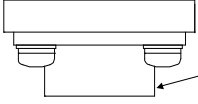
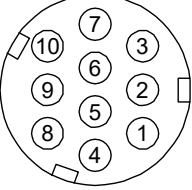

Part 9: Review on Replacement of Motor

(7) HA-LP series

Servo amplifier series	MR-J3 series	MR-J4 series																																																
Servo motor series	HA-LP	HG-SR																																																
Target models	HA-LP502	HG-SR502																																																
Motor appearance	 <p>Encoder connector</p> <p>Power connector</p>	 <p>Encoder connector</p> <p>Power connector</p>																																																
Power connector	 <p>CE05-2A24-10P</p>  <table border="1"> <thead> <tr> <th colspan="2">Power connector Pin assignment</th> </tr> <tr> <th>Pin No.</th> <th>Signal name</th> </tr> </thead> <tbody> <tr><td>A</td><td>U</td></tr> <tr><td>B</td><td>V</td></tr> <tr><td>C</td><td>W</td></tr> <tr><td>D</td><td>Earth</td></tr> <tr><td>E</td><td></td></tr> <tr><td>F</td><td></td></tr> <tr><td>G</td><td></td></tr> </tbody> </table>	Power connector Pin assignment		Pin No.	Signal name	A	U	B	V	C	W	D	Earth	E		F		G		 <p>MS3102A22-22P</p>  <table border="1"> <thead> <tr> <th colspan="2">Power connector Pin assignment</th> </tr> <tr> <th>Pin No.</th> <th>Signal name</th> </tr> </thead> <tbody> <tr><td>A</td><td>U</td></tr> <tr><td>B</td><td>V</td></tr> <tr><td>C</td><td>W</td></tr> <tr><td>D</td><td>Earth</td></tr> </tbody> </table>	Power connector Pin assignment		Pin No.	Signal name	A	U	B	V	C	W	D	Earth																		
Power connector Pin assignment																																																		
Pin No.	Signal name																																																	
A	U																																																	
B	V																																																	
C	W																																																	
D	Earth																																																	
E																																																		
F																																																		
G																																																		
Power connector Pin assignment																																																		
Pin No.	Signal name																																																	
A	U																																																	
B	V																																																	
C	W																																																	
D	Earth																																																	
Encoder connector (Note)	 <p>CM10-R10P</p>  <table border="1"> <thead> <tr> <th colspan="2">Encoder connector Pin assignment</th> </tr> <tr> <th>Pin No.</th> <th>Signal name</th> </tr> </thead> <tbody> <tr><td>1</td><td>MR</td></tr> <tr><td>2</td><td>MRR</td></tr> <tr><td>3</td><td></td></tr> <tr><td>4</td><td>BAT</td></tr> <tr><td>5</td><td>LG</td></tr> <tr><td>6</td><td></td></tr> <tr><td>7</td><td></td></tr> <tr><td>8</td><td>P5</td></tr> <tr><td>9</td><td></td></tr> <tr><td>10</td><td>SHD</td></tr> </tbody> </table>	Encoder connector Pin assignment		Pin No.	Signal name	1	MR	2	MRR	3		4	BAT	5	LG	6		7		8	P5	9		10	SHD	 <p>CMV1-R10P</p>  <table border="1"> <thead> <tr> <th colspan="2">Encoder connector Pin assignment</th> </tr> <tr> <th>Pin No.</th> <th>Signal name</th> </tr> </thead> <tbody> <tr><td>1</td><td>MR</td></tr> <tr><td>2</td><td>MRR</td></tr> <tr><td>3</td><td></td></tr> <tr><td>4</td><td>BAT</td></tr> <tr><td>5</td><td>LG</td></tr> <tr><td>6</td><td></td></tr> <tr><td>7</td><td></td></tr> <tr><td>8</td><td>P5</td></tr> <tr><td>9</td><td></td></tr> <tr><td>10</td><td>SHD</td></tr> </tbody> </table>	Encoder connector Pin assignment		Pin No.	Signal name	1	MR	2	MRR	3		4	BAT	5	LG	6		7		8	P5	9		10	SHD
Encoder connector Pin assignment																																																		
Pin No.	Signal name																																																	
1	MR																																																	
2	MRR																																																	
3																																																		
4	BAT																																																	
5	LG																																																	
6																																																		
7																																																		
8	P5																																																	
9																																																		
10	SHD																																																	
Encoder connector Pin assignment																																																		
Pin No.	Signal name																																																	
1	MR																																																	
2	MRR																																																	
3																																																		
4	BAT																																																	
5	LG																																																	
6																																																		
7																																																		
8	P5																																																	
9																																																		
10	SHD																																																	

Note. Although the encoder connector type differs, it can be wired with the existing cables because the connector specifications have compatibility in wiring.

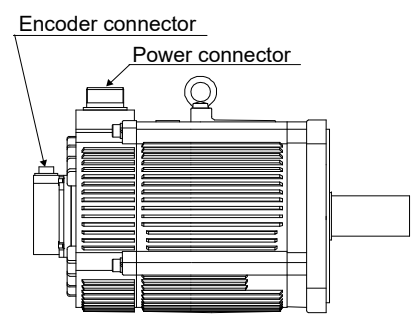
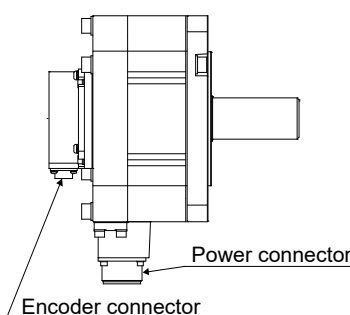
Part 9: Review on Replacement of Motor

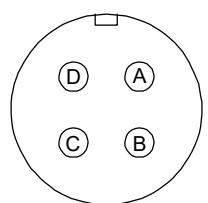
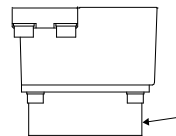
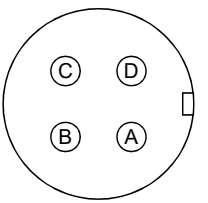
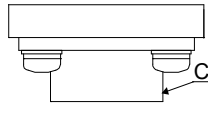
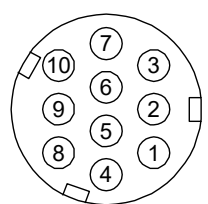
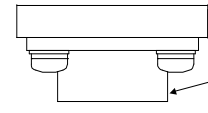
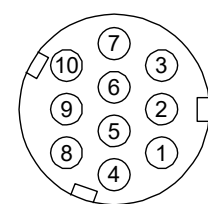
Servo amplifier series	MR-J3 series	MR-J4 series																																																
Servo motor series	HA-LP	HG-SR																																																
Target models	HA-LP702	HG-SR702																																																
Motor appearance	 <p>Encoder connector</p> <p>Power connector</p>	 <p>Power connector</p> <p>Encoder connector</p>																																																
Power connector	 <p>CE05-2A32-17P</p>  <table border="1"> <thead> <tr> <th colspan="2">Power connector Pin assignment</th> </tr> <tr> <th>Pin No.</th> <th>Signal name</th> </tr> </thead> <tbody> <tr> <td>A</td> <td>U</td> </tr> <tr> <td>B</td> <td>V</td> </tr> <tr> <td>C</td> <td>W</td> </tr> <tr> <td>D</td> <td>Earth</td> </tr> </tbody> </table>	Power connector Pin assignment		Pin No.	Signal name	A	U	B	V	C	W	D	Earth	 <p>MS3102A32-17P</p>  <table border="1"> <thead> <tr> <th colspan="2">Power connector Pin assignment</th> </tr> <tr> <th>Pin No.</th> <th>Signal name</th> </tr> </thead> <tbody> <tr> <td>A</td> <td>U</td> </tr> <tr> <td>B</td> <td>V</td> </tr> <tr> <td>C</td> <td>W</td> </tr> <tr> <td>D</td> <td>Earth</td> </tr> </tbody> </table>	Power connector Pin assignment		Pin No.	Signal name	A	U	B	V	C	W	D	Earth																								
Power connector Pin assignment																																																		
Pin No.	Signal name																																																	
A	U																																																	
B	V																																																	
C	W																																																	
D	Earth																																																	
Power connector Pin assignment																																																		
Pin No.	Signal name																																																	
A	U																																																	
B	V																																																	
C	W																																																	
D	Earth																																																	
Encoder connector (Note)	 <p>CM10-R10P</p>  <table border="1"> <thead> <tr> <th colspan="2">Encoder connector Pin assignment</th> </tr> <tr> <th>Pin No.</th> <th>Signal name</th> </tr> </thead> <tbody> <tr> <td>1</td> <td>MR</td> </tr> <tr> <td>2</td> <td>MRR</td> </tr> <tr> <td>3</td> <td></td> </tr> <tr> <td>4</td> <td>BAT</td> </tr> <tr> <td>5</td> <td>LG</td> </tr> <tr> <td>6</td> <td></td> </tr> <tr> <td>7</td> <td></td> </tr> <tr> <td>8</td> <td>P5</td> </tr> <tr> <td>9</td> <td></td> </tr> <tr> <td>10</td> <td>SHD</td> </tr> </tbody> </table>	Encoder connector Pin assignment		Pin No.	Signal name	1	MR	2	MRR	3		4	BAT	5	LG	6		7		8	P5	9		10	SHD	 <p>CMV1-R10P</p>  <table border="1"> <thead> <tr> <th colspan="2">Encoder connector Pin assignment</th> </tr> <tr> <th>Pin No.</th> <th>Signal name</th> </tr> </thead> <tbody> <tr> <td>1</td> <td>MR</td> </tr> <tr> <td>2</td> <td>MRR</td> </tr> <tr> <td>3</td> <td></td> </tr> <tr> <td>4</td> <td>BAT</td> </tr> <tr> <td>5</td> <td>LG</td> </tr> <tr> <td>6</td> <td></td> </tr> <tr> <td>7</td> <td></td> </tr> <tr> <td>8</td> <td>P5</td> </tr> <tr> <td>9</td> <td></td> </tr> <tr> <td>10</td> <td>SHD</td> </tr> </tbody> </table>	Encoder connector Pin assignment		Pin No.	Signal name	1	MR	2	MRR	3		4	BAT	5	LG	6		7		8	P5	9		10	SHD
Encoder connector Pin assignment																																																		
Pin No.	Signal name																																																	
1	MR																																																	
2	MRR																																																	
3																																																		
4	BAT																																																	
5	LG																																																	
6																																																		
7																																																		
8	P5																																																	
9																																																		
10	SHD																																																	
Encoder connector Pin assignment																																																		
Pin No.	Signal name																																																	
1	MR																																																	
2	MRR																																																	
3																																																		
4	BAT																																																	
5	LG																																																	
6																																																		
7																																																		
8	P5																																																	
9																																																		
10	SHD																																																	

Note. Although the encoder connector type differs, it can be wired with the existing cables because the connector specifications have compatibility in wiring.

Part 9: Review on Replacement of Motor

Servo amplifier series	MR-J3 series	MR-J4 series																																																										
Servo motor series	HA-LP	HG-JR																																																										
Target models	HA-LP601(4)(B)/HA-LP701M(4)(B)/ HA-LP11K2(4)(B)	HG-JR601(4)(B)/HG-JR701M(4)(B)/ HG-JR11K1M(4)(B)																																																										
Motor appearance																																																												
Power connector (Enlarged view of terminal box)		<table border="1"> <caption>Power connector Pin assignment</caption> <thead> <tr> <th>Pin No.</th> <th>Signal name</th> </tr> </thead> <tbody> <tr> <td>A</td> <td>U</td> </tr> <tr> <td>B</td> <td>V</td> </tr> <tr> <td>C</td> <td>W</td> </tr> <tr> <td>D</td> <td>Earth</td> </tr> </tbody> </table>	Pin No.	Signal name	A	U	B	V	C	W	D	Earth																																																
Pin No.	Signal name																																																											
A	U																																																											
B	V																																																											
C	W																																																											
D	Earth																																																											
Encoder connector	<table border="1"> <caption>Encoder connector Pin assignment</caption> <thead> <tr> <th>Pin No.</th> <th>Signal name</th> </tr> </thead> <tbody> <tr> <td>1</td> <td>MR</td> </tr> <tr> <td>2</td> <td>MRR</td> </tr> <tr> <td>3</td> <td></td> </tr> <tr> <td>4</td> <td>BAT</td> </tr> <tr> <td>5</td> <td>LG</td> </tr> <tr> <td>6</td> <td></td> </tr> <tr> <td>7</td> <td></td> </tr> <tr> <td>8</td> <td>P5</td> </tr> <tr> <td>9</td> <td></td> </tr> <tr> <td>10</td> <td>SHD</td> </tr> </tbody> </table>	Pin No.	Signal name	1	MR	2	MRR	3		4	BAT	5	LG	6		7		8	P5	9		10	SHD	<table border="1"> <caption>Encoder connector Pin assignment</caption> <thead> <tr> <th>Pin No.</th> <th>Signal name</th> </tr> </thead> <tbody> <tr> <td>A</td> <td></td> </tr> <tr> <td>B</td> <td></td> </tr> <tr> <td>C</td> <td>MR</td> </tr> <tr> <td>D</td> <td>MRR</td> </tr> <tr> <td>E</td> <td></td> </tr> <tr> <td>F</td> <td>BAT</td> </tr> <tr> <td>G</td> <td>LG</td> </tr> <tr> <td>H</td> <td></td> </tr> <tr> <td>J</td> <td></td> </tr> <tr> <td>K</td> <td></td> </tr> <tr> <td>L</td> <td></td> </tr> <tr> <td>M</td> <td></td> </tr> <tr> <td>N</td> <td>SHD</td> </tr> <tr> <td>P</td> <td></td> </tr> <tr> <td>R</td> <td>LG</td> </tr> <tr> <td>S</td> <td>P5</td> </tr> <tr> <td>T</td> <td></td> </tr> </tbody> </table>	Pin No.	Signal name	A		B		C	MR	D	MRR	E		F	BAT	G	LG	H		J		K		L		M		N	SHD	P		R	LG	S	P5	T	
Pin No.	Signal name																																																											
1	MR																																																											
2	MRR																																																											
3																																																												
4	BAT																																																											
5	LG																																																											
6																																																												
7																																																												
8	P5																																																											
9																																																												
10	SHD																																																											
Pin No.	Signal name																																																											
A																																																												
B																																																												
C	MR																																																											
D	MRR																																																											
E																																																												
F	BAT																																																											
G	LG																																																											
H																																																												
J																																																												
K																																																												
L																																																												
M																																																												
N	SHD																																																											
P																																																												
R	LG																																																											
S	P5																																																											
T																																																												
Electromagnetic brake connector (Note)	<table border="1"> <caption>Electromagnetic brake connector Pin assignment</caption> <thead> <tr> <th>Pin No.</th> <th>Signal name</th> </tr> </thead> <tbody> <tr> <td>A</td> <td>B1</td> </tr> <tr> <td>B</td> <td>B2</td> </tr> </tbody> </table>	Pin No.	Signal name	A	B1	B	B2	<table border="1"> <caption>Electromagnetic brake connector Pin assignment</caption> <thead> <tr> <th>Pin No.</th> <th>Signal name</th> </tr> </thead> <tbody> <tr> <td>A</td> <td>B1</td> </tr> <tr> <td>B</td> <td>B2</td> </tr> </tbody> </table>	Pin No.	Signal name	A	B1	B	B2																																														
Pin No.	Signal name																																																											
A	B1																																																											
B	B2																																																											
Pin No.	Signal name																																																											
A	B1																																																											
B	B2																																																											

Part 9: Review on Replacement of Motor

Servo amplifier series	MR-J3 series	MR-J4 series																																																										
Servo motor series	HA-LP	HG-JR																																																										
Target models	HA-LP801(4)(B)/HA-LP12K1(4)(B)/ HA-LP11K1M(4)(B)/HA-LP15K1M(4)(B)/ HA-LP15K2(4)(B)/HA-LP22K2(4)(B)	HG-JR801(4)(B)/HG-JR12K1(4)(B)/ HG-JR11K1M(4)(B)/HG-JR15K1M(4)(B)																																																										
Motor appearance																																																												
Power connector (Enlarged view of terminal box)		<table border="1"> <caption>電源コネクタピン配列</caption> <thead> <tr> <th>ピン番号</th> <th>信号名</th> </tr> </thead> <tbody> <tr> <td>A</td> <td>U</td> </tr> <tr> <td>B</td> <td>V</td> </tr> <tr> <td>C</td> <td>W</td> </tr> <tr> <td>D</td> <td>アース</td> </tr> </tbody> </table>	ピン番号	信号名	A	U	B	V	C	W	D	アース																																																
ピン番号	信号名																																																											
A	U																																																											
B	V																																																											
C	W																																																											
D	アース																																																											
Encoder connector	<table border="1"> <caption>Encoder connector Pin assignment</caption> <thead> <tr> <th>Pin No.</th> <th>Signal name</th> </tr> </thead> <tbody> <tr> <td>1</td> <td>MR</td> </tr> <tr> <td>2</td> <td>MRR</td> </tr> <tr> <td>3</td> <td></td> </tr> <tr> <td>4</td> <td>BAT</td> </tr> <tr> <td>5</td> <td>LG</td> </tr> <tr> <td>6</td> <td></td> </tr> <tr> <td>7</td> <td></td> </tr> <tr> <td>8</td> <td>P5</td> </tr> <tr> <td>9</td> <td></td> </tr> <tr> <td>10</td> <td>SHD</td> </tr> </tbody> </table>	Pin No.	Signal name	1	MR	2	MRR	3		4	BAT	5	LG	6		7		8	P5	9		10	SHD	<table border="1"> <caption>Encoder connector Pin assignment</caption> <thead> <tr> <th>Pin No.</th> <th>Signal name</th> </tr> </thead> <tbody> <tr> <td>A</td> <td></td> </tr> <tr> <td>B</td> <td></td> </tr> <tr> <td>C</td> <td>MR</td> </tr> <tr> <td>D</td> <td>MRR</td> </tr> <tr> <td>E</td> <td></td> </tr> <tr> <td>F</td> <td>BAT</td> </tr> <tr> <td>G</td> <td>LG</td> </tr> <tr> <td>H</td> <td></td> </tr> <tr> <td>J</td> <td></td> </tr> <tr> <td>K</td> <td></td> </tr> <tr> <td>L</td> <td></td> </tr> <tr> <td>M</td> <td></td> </tr> <tr> <td>N</td> <td>SHD</td> </tr> <tr> <td>P</td> <td></td> </tr> <tr> <td>R</td> <td>LG</td> </tr> <tr> <td>S</td> <td>P5</td> </tr> <tr> <td>T</td> <td></td> </tr> </tbody> </table>	Pin No.	Signal name	A		B		C	MR	D	MRR	E		F	BAT	G	LG	H		J		K		L		M		N	SHD	P		R	LG	S	P5	T	
Pin No.	Signal name																																																											
1	MR																																																											
2	MRR																																																											
3																																																												
4	BAT																																																											
5	LG																																																											
6																																																												
7																																																												
8	P5																																																											
9																																																												
10	SHD																																																											
Pin No.	Signal name																																																											
A																																																												
B																																																												
C	MR																																																											
D	MRR																																																											
E																																																												
F	BAT																																																											
G	LG																																																											
H																																																												
J																																																												
K																																																												
L																																																												
M																																																												
N	SHD																																																											
P																																																												
R	LG																																																											
S	P5																																																											
T																																																												
Electromagnetic brake connector (Note)	<table border="1"> <caption>Electromagnetic brake connector Pin assignment</caption> <thead> <tr> <th>Pin No.</th> <th>Signal name</th> </tr> </thead> <tbody> <tr> <td>A</td> <td>B1</td> </tr> <tr> <td>B</td> <td>B2</td> </tr> </tbody> </table>	Pin No.	Signal name	A	B1	B	B2	<table border="1"> <caption>Electromagnetic brake connector Pin assignment</caption> <thead> <tr> <th>Pin No.</th> <th>Signal name</th> </tr> </thead> <tbody> <tr> <td>A</td> <td>B1</td> </tr> <tr> <td>B</td> <td>B2</td> </tr> </tbody> </table>	Pin No.	Signal name	A	B1	B	B2																																														
Pin No.	Signal name																																																											
A	B1																																																											
B	B2																																																											
Pin No.	Signal name																																																											
A	B1																																																											
B	B2																																																											

Part 9: Review on Replacement of Motor

Servo amplifier series	MR-J3 series	MR-J4 series																																																														
Servo motor series	HA-LP	HG-JR																																																														
Target models	HA-LP15K1(4)/HA-LP20K1(4)/HA-LP22K1M(4)/ HA-LP30K1M4/HA-LP30K24/HA-LP37K24	HG-JR15K1(4)/HG-JR20K1(4)/ HG-JR22K1M(4)/HG-JR30K1M4																																																														
Motor appearance	<p>Power supply terminal block</p> <p>Encoder connector</p>	<p>Cooling fan connector</p> <p>Power supply terminal block</p> <p>Encoder connector</p>																																																														
Power connector (Enlarged view of terminal box)	<p>Power supply terminal block U/V/W terminals, M8 screw</p> <p>Earth terminal M6 screw</p> <p>Terminal block for thermal OHS1/OHS2, M4 screw</p> <p>Terminal block for cooling fan BU/BV terminal, M4 screw</p>	<p>Power supply terminal block U/V/W terminals, M10 screw</p> <p>Earth terminal M10 screw</p>																																																														
Encoder connector	<p>CM10-R10P</p> <table border="1"> <thead> <tr> <th colspan="2">Encoder connector Pin assignment</th> </tr> <tr> <th>Pin No.</th> <th>Signal name</th> </tr> </thead> <tbody> <tr><td>1</td><td>MR</td></tr> <tr><td>2</td><td>MRR</td></tr> <tr><td>3</td><td></td></tr> <tr><td>4</td><td>BAT</td></tr> <tr><td>5</td><td>LG</td></tr> <tr><td>6</td><td></td></tr> <tr><td>7</td><td></td></tr> <tr><td>8</td><td>P5</td></tr> <tr><td>9</td><td></td></tr> <tr><td>10</td><td>SHD</td></tr> </tbody> </table>	Encoder connector Pin assignment		Pin No.	Signal name	1	MR	2	MRR	3		4	BAT	5	LG	6		7		8	P5	9		10	SHD	<p>MS3102A20-29P</p> <table border="1"> <thead> <tr> <th colspan="2">Encoder connector Pin assignment</th> </tr> <tr> <th>Pin No.</th> <th>Signal name</th> </tr> </thead> <tbody> <tr><td>A</td><td></td></tr> <tr><td>B</td><td></td></tr> <tr><td>C</td><td>MR</td></tr> <tr><td>D</td><td>MRR</td></tr> <tr><td>E</td><td></td></tr> <tr><td>F</td><td>BAT</td></tr> <tr><td>G</td><td>LG</td></tr> <tr><td>H</td><td></td></tr> <tr><td>J</td><td></td></tr> <tr><td>K</td><td></td></tr> <tr><td>L</td><td></td></tr> <tr><td>M</td><td></td></tr> <tr><td>N</td><td>SHD</td></tr> <tr><td>P</td><td></td></tr> <tr><td>R</td><td>LG</td></tr> <tr><td>S</td><td>P5</td></tr> <tr><td>T</td><td></td></tr> </tbody> </table>	Encoder connector Pin assignment		Pin No.	Signal name	A		B		C	MR	D	MRR	E		F	BAT	G	LG	H		J		K		L		M		N	SHD	P		R	LG	S	P5	T	
Encoder connector Pin assignment																																																																
Pin No.	Signal name																																																															
1	MR																																																															
2	MRR																																																															
3																																																																
4	BAT																																																															
5	LG																																																															
6																																																																
7																																																																
8	P5																																																															
9																																																																
10	SHD																																																															
Encoder connector Pin assignment																																																																
Pin No.	Signal name																																																															
A																																																																
B																																																																
C	MR																																																															
D	MRR																																																															
E																																																																
F	BAT																																																															
G	LG																																																															
H																																																																
J																																																																
K																																																																
L																																																																
M																																																																
N	SHD																																																															
P																																																																
R	LG																																																															
S	P5																																																															
T																																																																
Electromagnetic brake connector (Note)		<p>CE05-2A14S-2P</p> <table border="1"> <thead> <tr> <th colspan="2">Cooling fan connector Pin assignment</th> </tr> <tr> <th>Pin No.</th> <th>Signal name</th> </tr> </thead> <tbody> <tr><td>A</td><td>BU</td></tr> <tr><td>B</td><td>BV</td></tr> <tr><td>C</td><td>BW</td></tr> <tr><td>D</td><td></td></tr> </tbody> </table>	Cooling fan connector Pin assignment		Pin No.	Signal name	A	BU	B	BV	C	BW	D																																																			
Cooling fan connector Pin assignment																																																																
Pin No.	Signal name																																																															
A	BU																																																															
B	BV																																																															
C	BW																																																															
D																																																																

Note. The new setting of a encoder cable is required since the thermistor is added to the encoder-side connector.

Part 9: Review on Replacement of Motor

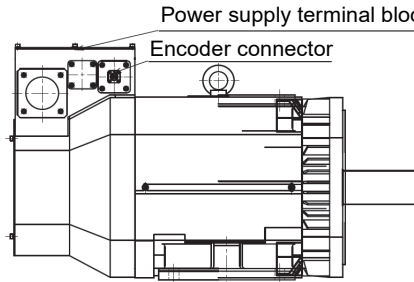
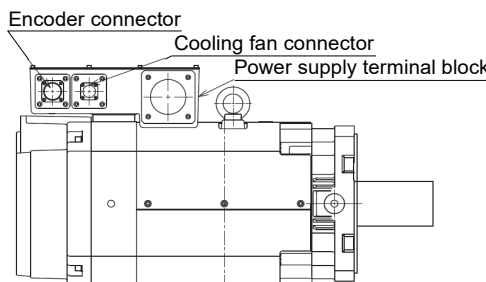
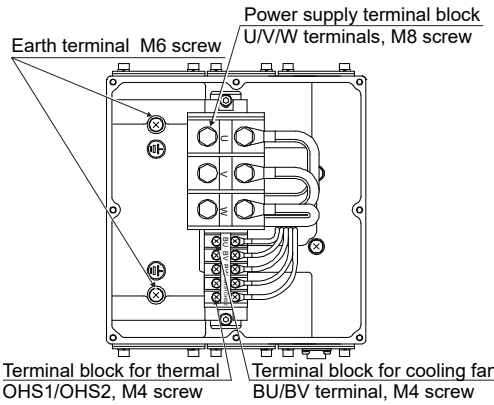
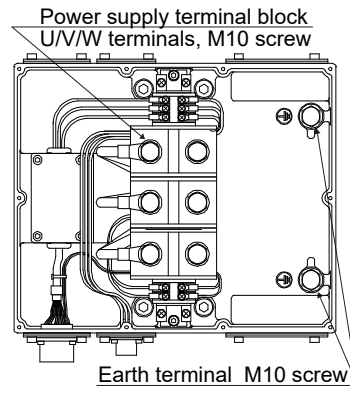
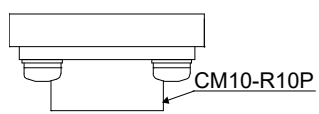
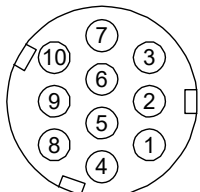
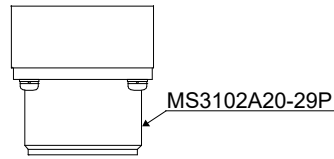
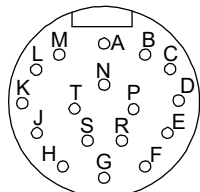
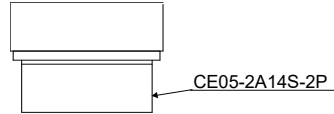
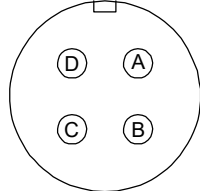
Servo amplifier series	MR-J3 series	MR-J4 series																																																														
Servo motor series	HA-LP	HG-JR																																																														
Target models	HA-LP25K1(4) to HA-LP37K1(4)/ HA-LP30K1M/ HA-LP37K1M(4)/HA-LP45K1M4/HA-LP50K1M4/ HA-LP30K2/HA-LP37K2/HA-LP45K24/HA-LP55K24	HG-JR25K1(4) to HG-JR 37K1(4)/HG-JR22K1M/ HG-JR 30K1M/HG-JR 37K1M(4)/HG-JR45K1M4/ HG-JR55K1M4																																																														
Motor appearance	 <p>Power supply terminal block Encoder connector</p>	 <p>Encoder connector Cooling fan connector Power supply terminal block</p>																																																														
Power connector (Enlarged view of terminal box)	 <p>Power supply terminal block U/V/W terminals, M8 screw Earth terminal M6 screw Terminal block for thermal OHS1/OHS2, M4 screw Terminal block for cooling fan BU/BV terminal, M4 screw</p>	 <p>Power supply terminal block U/V/W terminals, M10 screw Earth terminal M10 screw</p>																																																														
Encoder connector	 <p>CM10-R10P</p> <table border="1" data-bbox="662 1265 909 1601"> <thead> <tr> <th colspan="2">Encoder connector Pin assignment</th> </tr> <tr> <th>Pin No.</th> <th>Signal name</th> </tr> </thead> <tbody> <tr><td>1</td><td>MR</td></tr> <tr><td>2</td><td>MRR</td></tr> <tr><td>3</td><td></td></tr> <tr><td>4</td><td>BAT</td></tr> <tr><td>5</td><td>LG</td></tr> <tr><td>6</td><td></td></tr> <tr><td>7</td><td></td></tr> <tr><td>8</td><td>P5</td></tr> <tr><td>9</td><td></td></tr> <tr><td>10</td><td>SHD</td></tr> </tbody> </table> 	Encoder connector Pin assignment		Pin No.	Signal name	1	MR	2	MRR	3		4	BAT	5	LG	6		7		8	P5	9		10	SHD	 <p>MS3102A20-29P</p> <table border="1" data-bbox="1181 1265 1428 1736"> <thead> <tr> <th colspan="2">Encoder connector Pin assignment</th> </tr> <tr> <th>Pin No.</th> <th>Signal name</th> </tr> </thead> <tbody> <tr><td>A</td><td></td></tr> <tr><td>B</td><td></td></tr> <tr><td>C</td><td>MR</td></tr> <tr><td>D</td><td>MRR</td></tr> <tr><td>E</td><td></td></tr> <tr><td>F</td><td>BAT</td></tr> <tr><td>G</td><td>LG</td></tr> <tr><td>H</td><td></td></tr> <tr><td>J</td><td></td></tr> <tr><td>K</td><td></td></tr> <tr><td>L</td><td></td></tr> <tr><td>M</td><td></td></tr> <tr><td>N</td><td>SHD</td></tr> <tr><td>P</td><td></td></tr> <tr><td>R</td><td>LG</td></tr> <tr><td>S</td><td>P5</td></tr> <tr><td>T</td><td></td></tr> </tbody> </table> 	Encoder connector Pin assignment		Pin No.	Signal name	A		B		C	MR	D	MRR	E		F	BAT	G	LG	H		J		K		L		M		N	SHD	P		R	LG	S	P5	T	
Encoder connector Pin assignment																																																																
Pin No.	Signal name																																																															
1	MR																																																															
2	MRR																																																															
3																																																																
4	BAT																																																															
5	LG																																																															
6																																																																
7																																																																
8	P5																																																															
9																																																																
10	SHD																																																															
Encoder connector Pin assignment																																																																
Pin No.	Signal name																																																															
A																																																																
B																																																																
C	MR																																																															
D	MRR																																																															
E																																																																
F	BAT																																																															
G	LG																																																															
H																																																																
J																																																																
K																																																																
L																																																																
M																																																																
N	SHD																																																															
P																																																																
R	LG																																																															
S	P5																																																															
T																																																																
Electromagnetic brake connector (Note)		 <p>CE05-2A14S-2P</p> <table border="1" data-bbox="1149 1892 1412 2083"> <thead> <tr> <th colspan="2">Cooling fan connector Pin assignment</th> </tr> <tr> <th>Pin No.</th> <th>Signal name</th> </tr> </thead> <tbody> <tr><td>A</td><td>BU</td></tr> <tr><td>B</td><td>BV</td></tr> <tr><td>C</td><td>BW</td></tr> <tr><td>D</td><td></td></tr> </tbody> </table> 	Cooling fan connector Pin assignment		Pin No.	Signal name	A	BU	B	BV	C	BW	D																																																			
Cooling fan connector Pin assignment																																																																
Pin No.	Signal name																																																															
A	BU																																																															
B	BV																																																															
C	BW																																																															
D																																																																

Part 9: Review on Replacement of Motor

2.7 Comparison of Servo Motor Torque Characteristics

(1) HF-KP series

Same torque characteristics

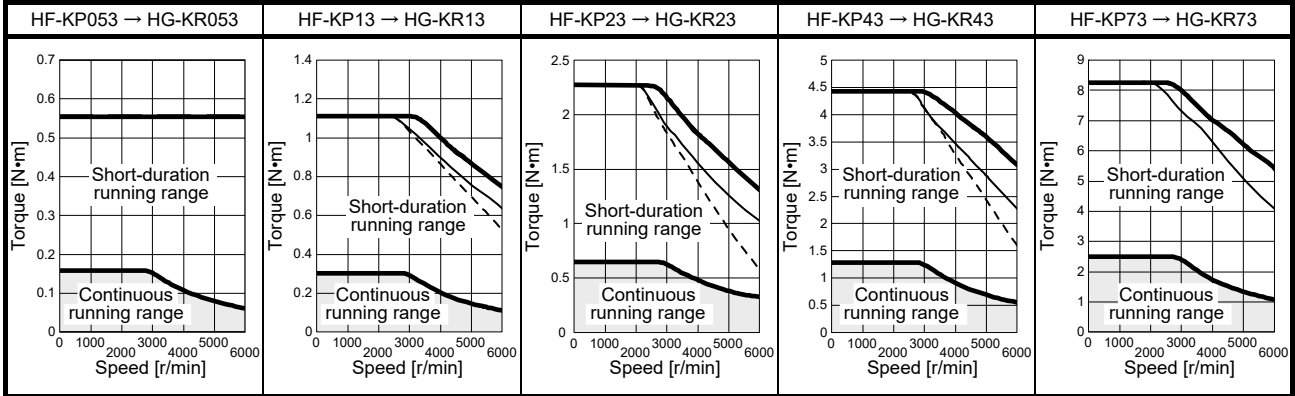

- Note
1. For the 3-phase 200 V AC and 1-phase 230 V AC power supplies, the torque characteristic is indicated by the heavy lines.
 2. For the 1-phase 200 V AC power supply, part of the torque characteristic is indicated by the thin line.
 3. For the 1-phase 100 V AC power supply, part of the torque characteristic is indicated by the broken line.
 4. The torque characteristics of the HF-KP series are the value of the maximally increased torque.

(2) HF-MP series

Same torque characteristics

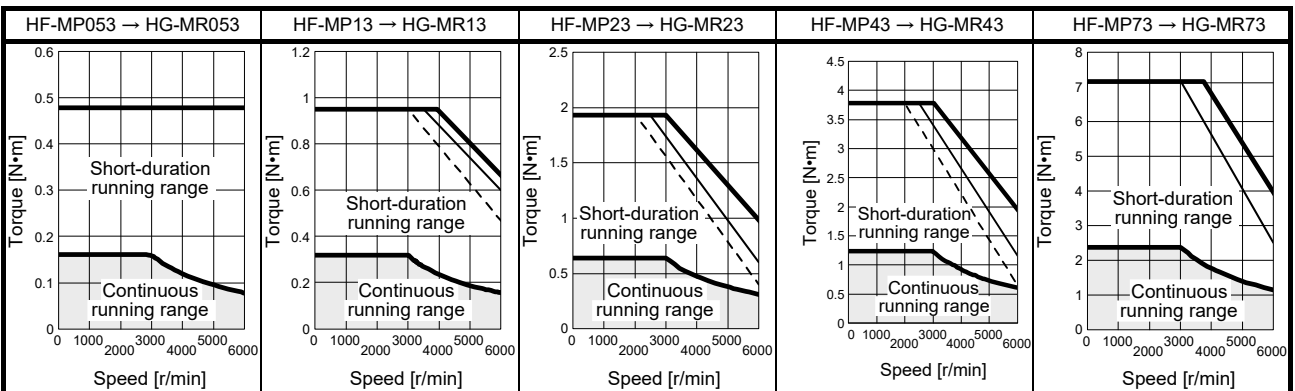

- Note
1. For the 3-phase 200 V AC and 1-phase 230 V AC power supplies, the torque characteristic is indicated by the heavy lines.
 2. For the 1-phase 200 V AC power supply, part of the torque characteristic is indicated by the thin line.
 3. For the 1-phase 100 V AC power supply, part of the torque characteristic is indicated by the broken line.

Part 9: Review on Replacement of Motor

(3) HF-SP series 200 V class

Same torque characteristics

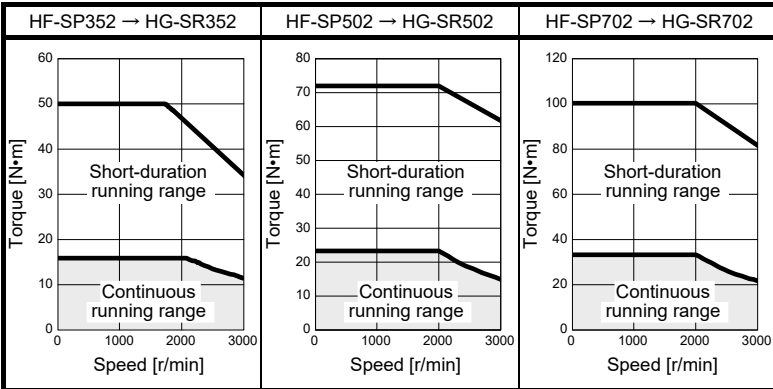
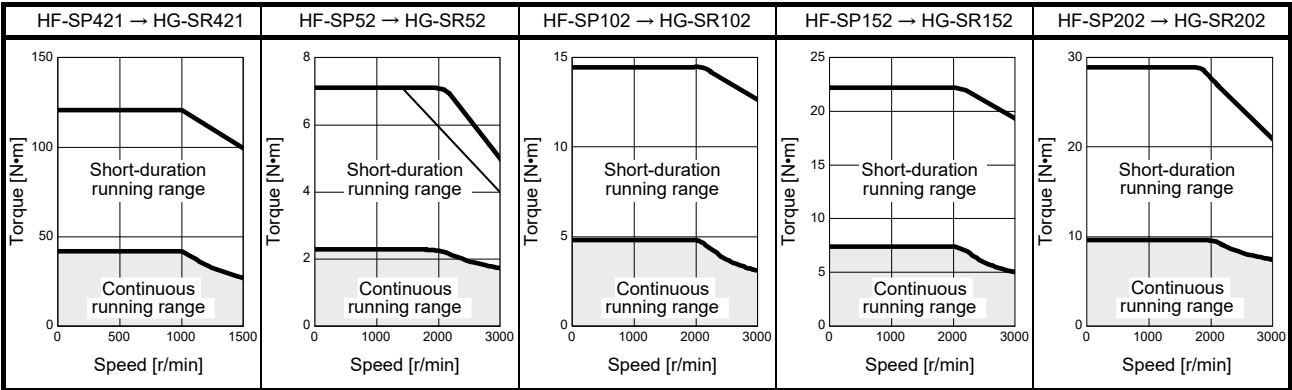
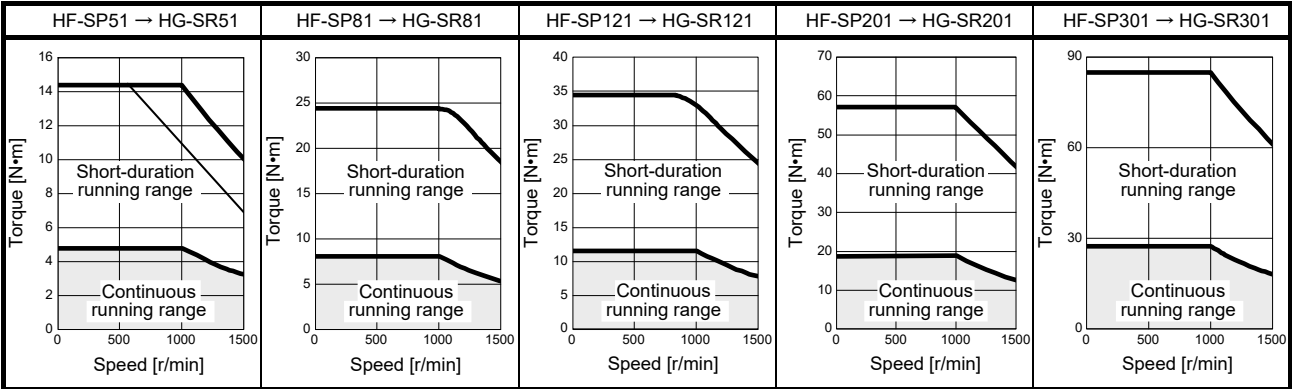

Note 1. For the 3-phase 200 V AC and 1-phase 230 V AC power supplies, the torque characteristic is indicated by the heavy lines.
 2. For the 1-phase 200 V AC power supply, part of the torque characteristic is indicated by the thin line.

Part 9: Review on Replacement of Motor

(4) HF-SP series 400 V class

Same torque characteristics

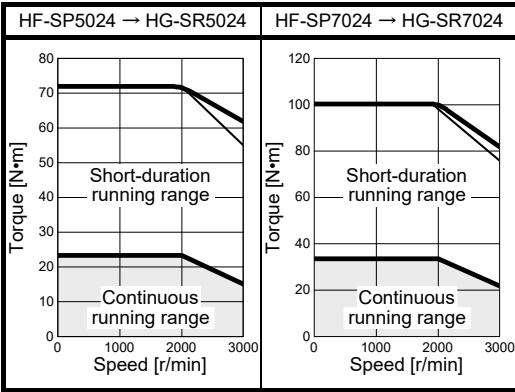
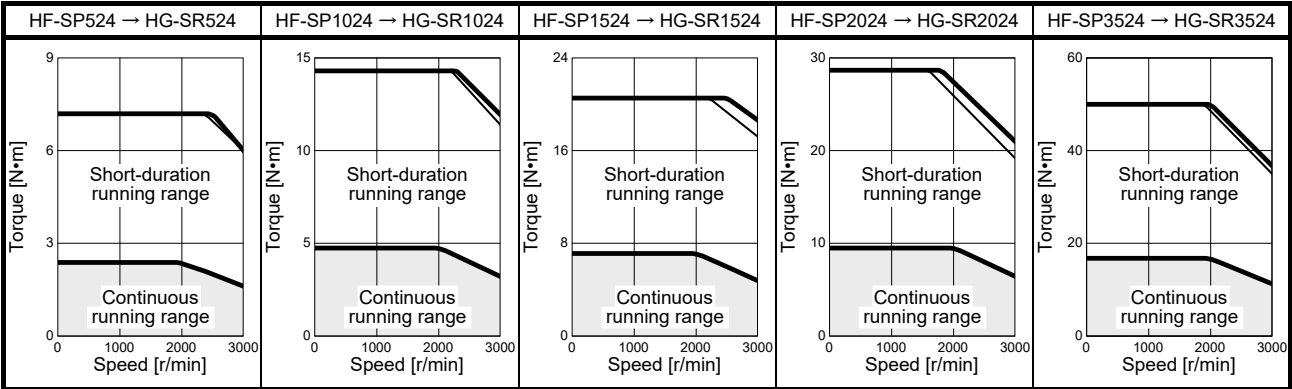

Note 1. For the 3-phase 400 V AC power supply, the torque characteristic is indicated by the heavy line.
 2. For the 1-phase 380 V AC power supply, part of the torque characteristic is indicated by the thin line.

(5) HC-RP series

Same torque characteristics

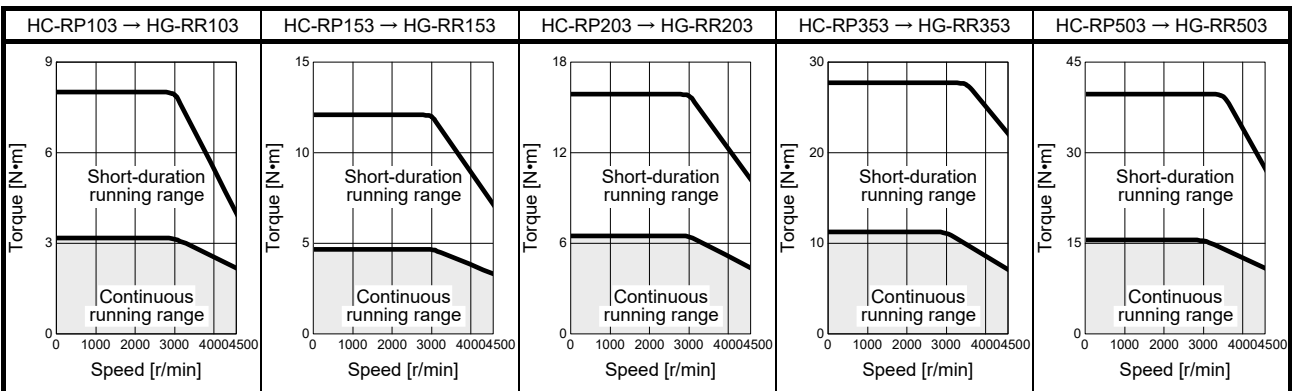

Note. The above torque characteristics are for 3-phase 200 V AC.

Part 9: Review on Replacement of Motor

(6) HC-LP series (— : HG-JR, - - - : HC-LP)

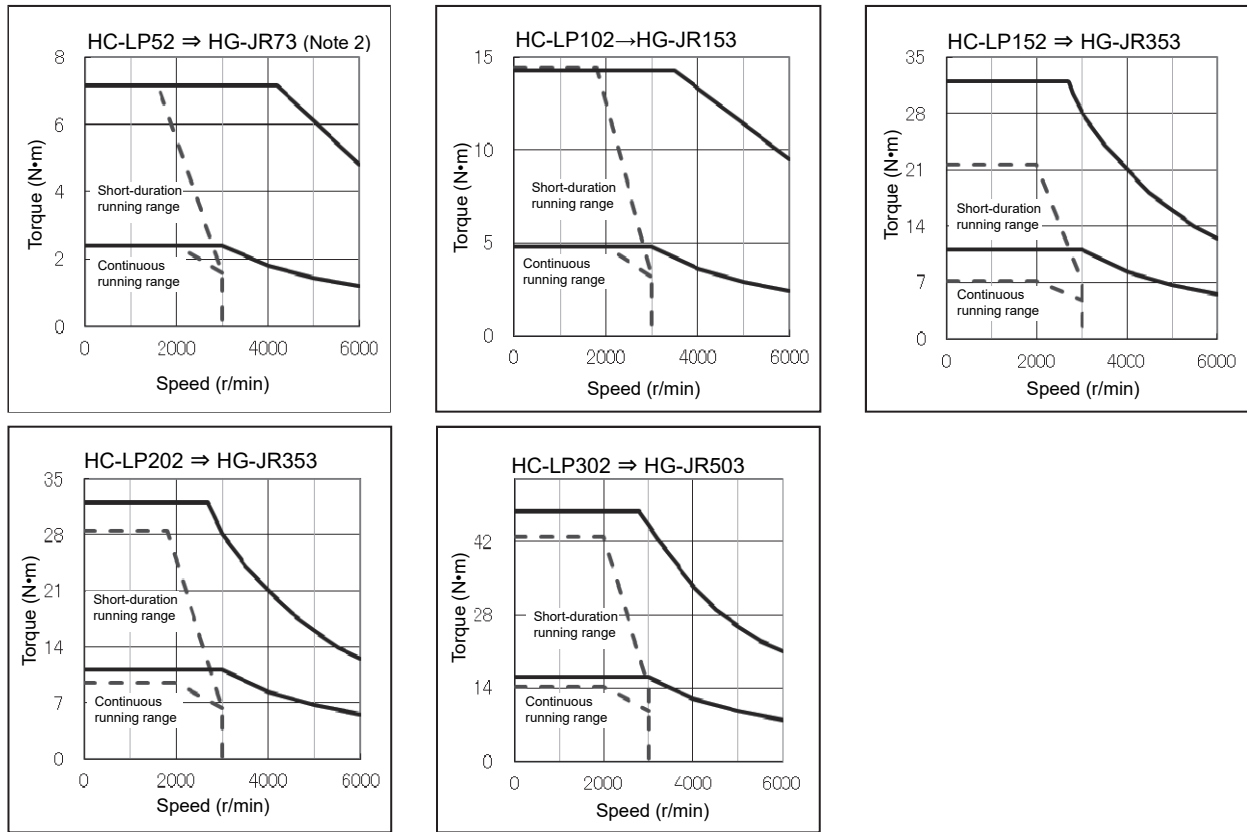

- Note 1. The above torque characteristics are for 3-phase 200 V AC.
 2. For the 1-phase 230 V AC power supply, please contact your local sales office.

(7) HC-UP series

Same torque characteristics

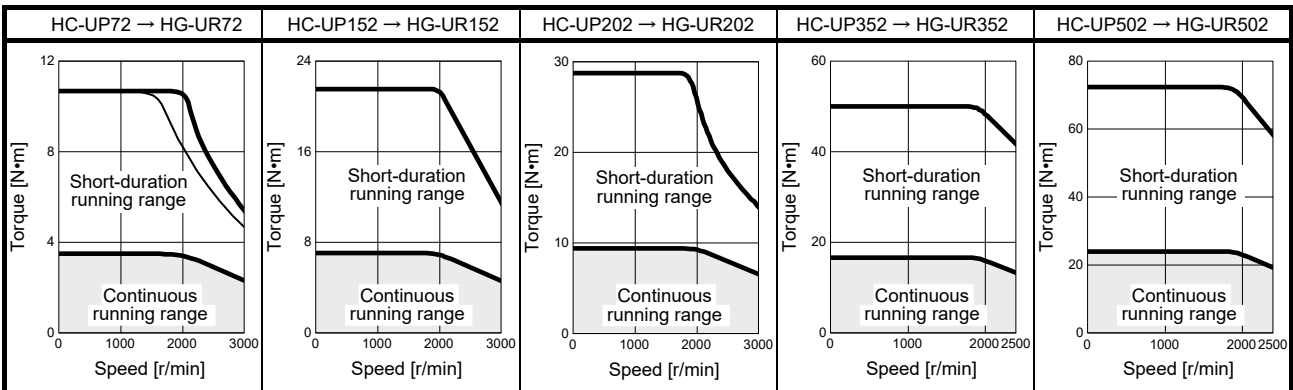

- Note 1. The above torque characteristics are for 3-phase 200 V AC.
 2. For the 1-phase 200 V AC power supply, part of the torque characteristic is indicated by the thin line.

Part 9: Review on Replacement of Motor

(8) HF-JP series

Same torque characteristics

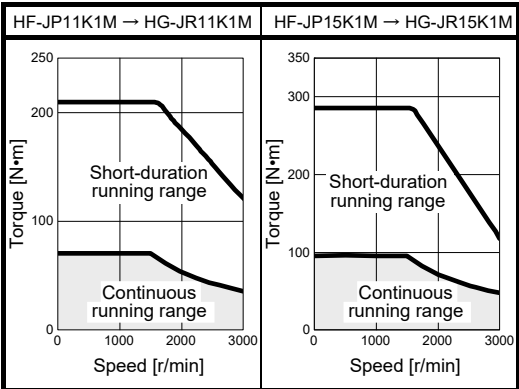
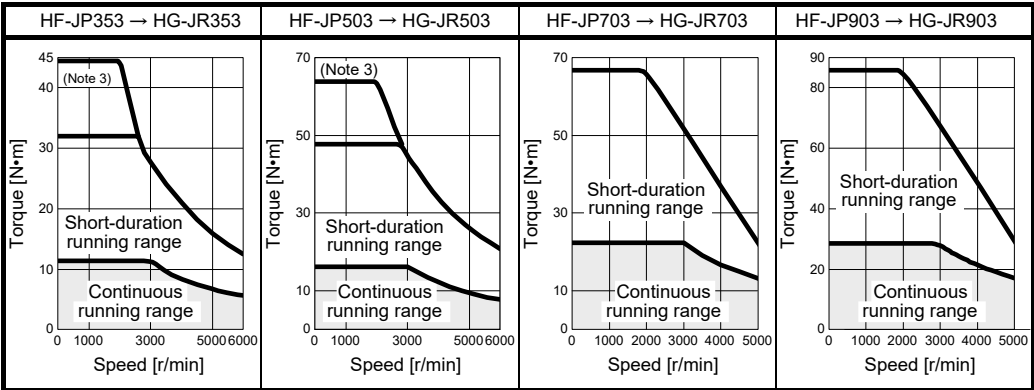
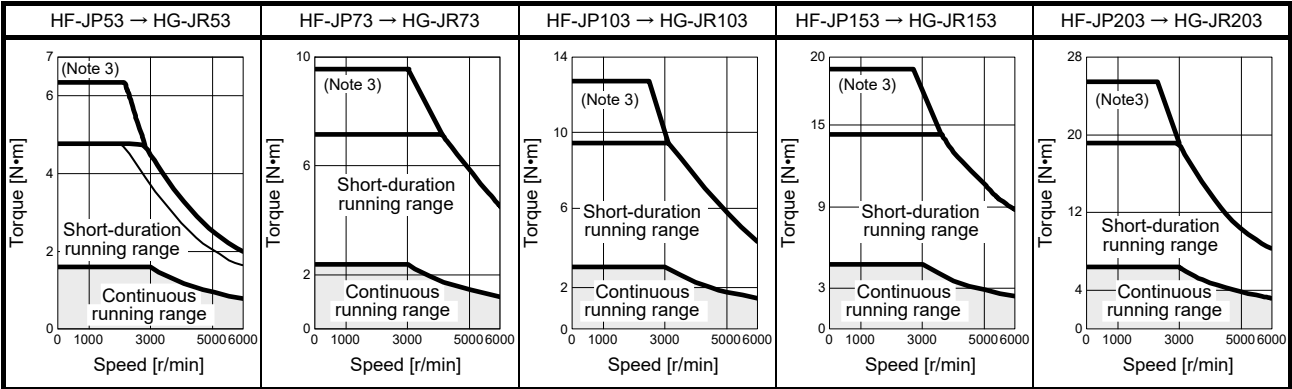

Note 1. For the 3-phase 200 V AC and 1-phase 230 V AC power supplies, the torque characteristic is indicated by the heavy lines.
 Note 2. For the 1-phase 200 V AC power supply, part of the torque characteristic is indicated by the thin line.
 Note 3. Value at the maximum torque 400%.

Part 9: Review on Replacement of Motor

(9) HA-LP series (— : HG-JR/HG-SR, - - - : HA-LP)

POINT

● When servo motors are replaced with HG-JR_R_-S_ motors (compatible product), the torque characteristics differ. Please contact your local sales office.

(a) HA-LP 1000 r/min series 200 V class

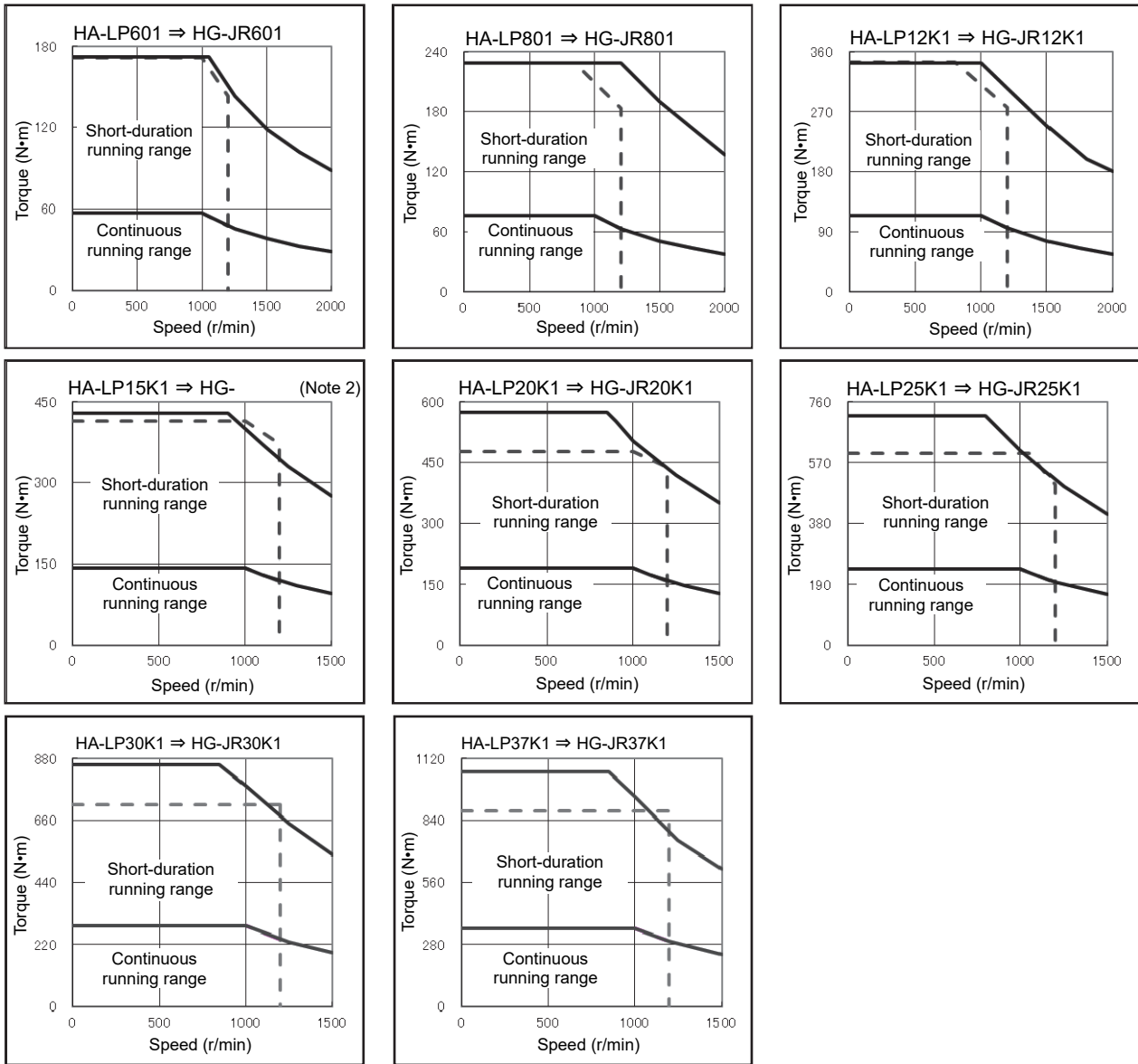

- Note 1. The above torque characteristics are for 3-phase 200 V AC.
 Note 2. Please contact your local sales office if the compatibility of torque characteristics is required.

Part 9: Review on Replacement of Motor

(b) HA-LP 1000 r/min series 400 Vclass

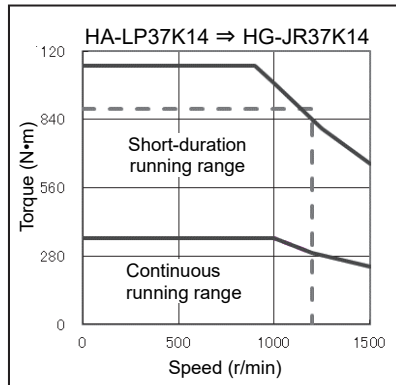
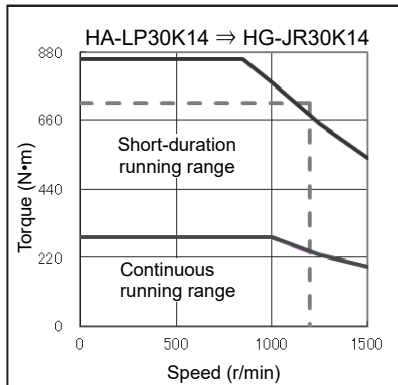
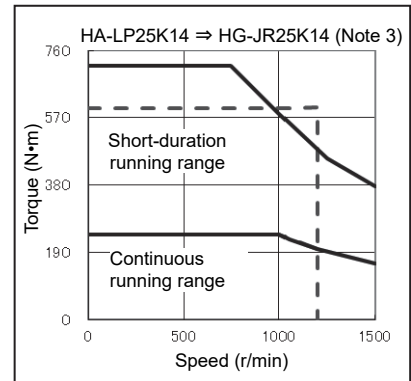
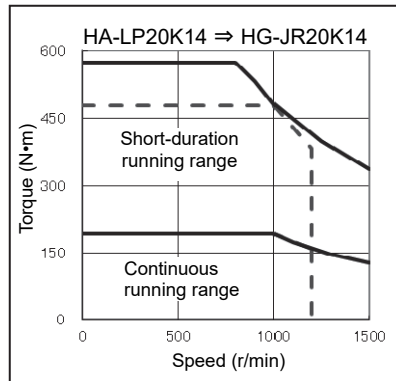
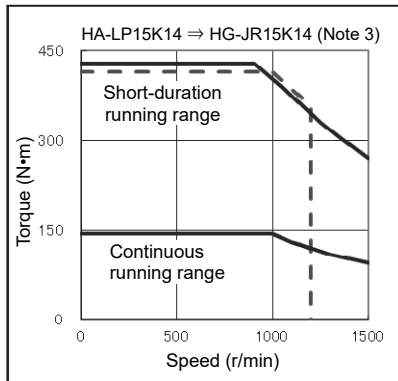
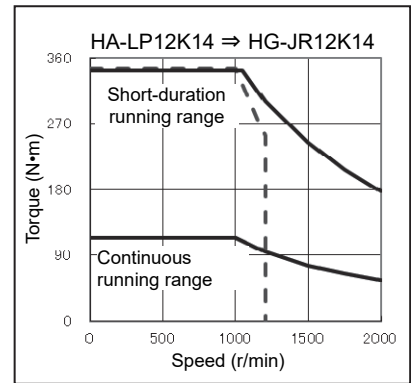
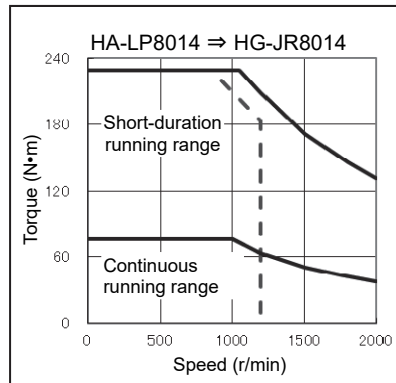
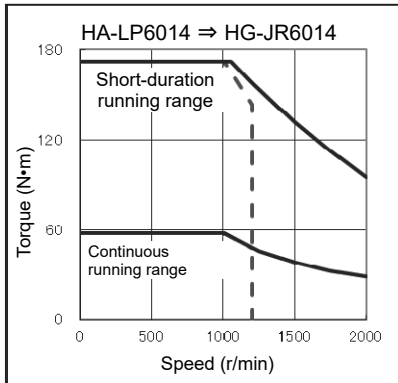

- Note
1. The above torque characteristics are for 3-phase 400 V AC.
 2. As for 3-phase 380 V AC, refer to the catalog or instruction manual.
 3. Please contact your local sales office if the compatibility of torque characteristics is required.

Part 9: Review on Replacement of Motor

(c) HA-LP 1500 r/min series 200 V class

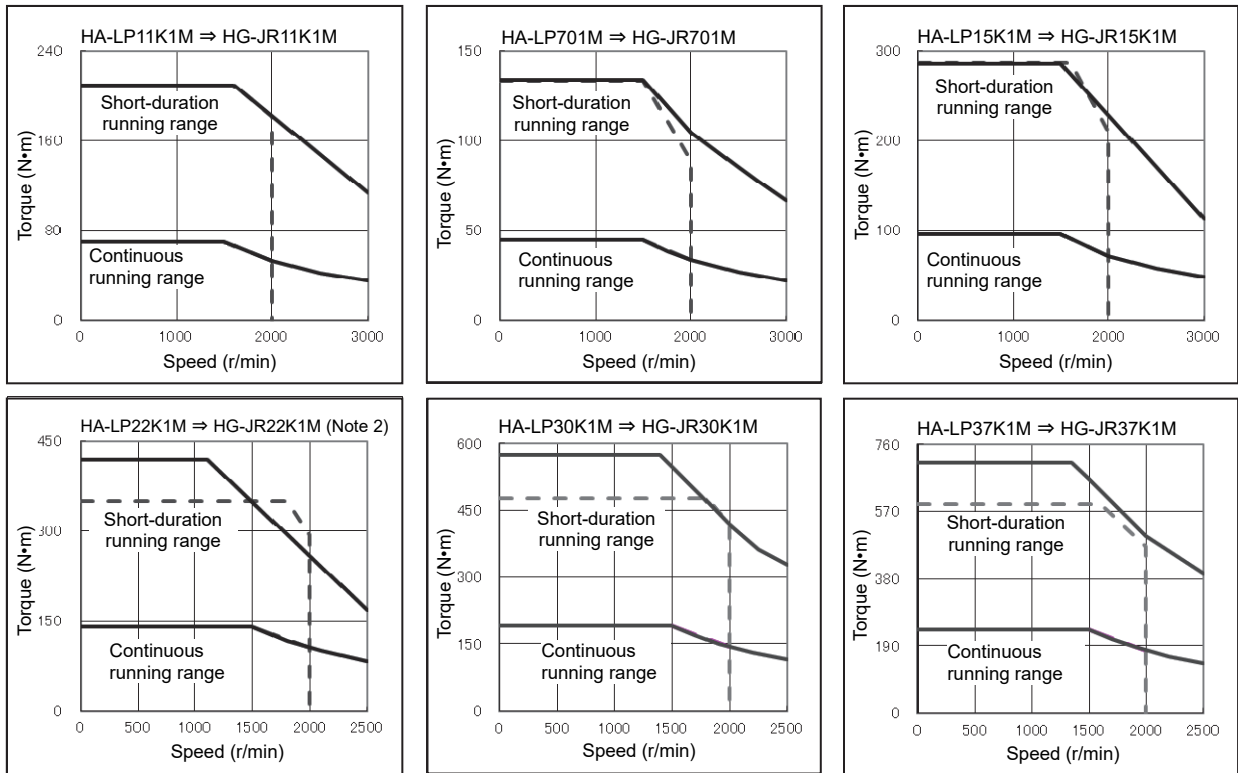

- Note 1. The above torque characteristics are for 3-phase 200 V AC.
 Note 2. Please contact your local sales office if the compatibility of torque characteristics is required.

Part 9: Review on Replacement of Motor

(d) HA-LP 1500 r/min series 400 V class

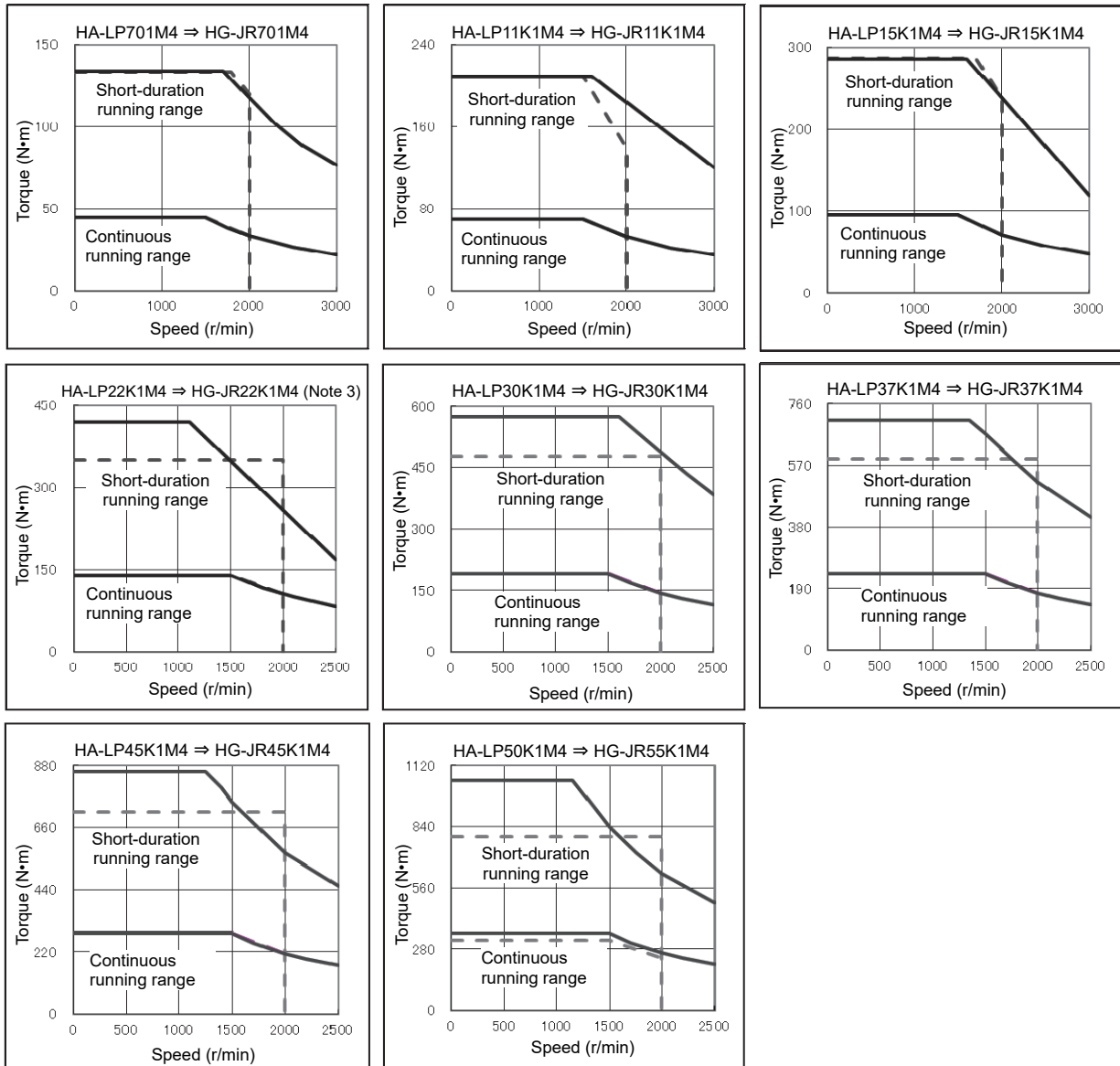

- Note
1. The above torque characteristics are for 3-phase 400 V AC.
 2. As for 3-phase 380V AC, refer to the catalog or Instruction Manual.
 3. Please contact your local sales office if the compatibility of torque characteristics is required.

Part 9: Review on Replacement of Motor

(e) HA-LP 2000 r/min series 200 V class

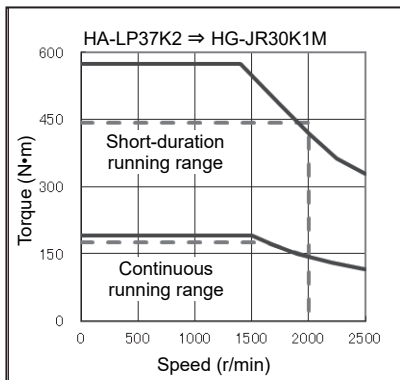
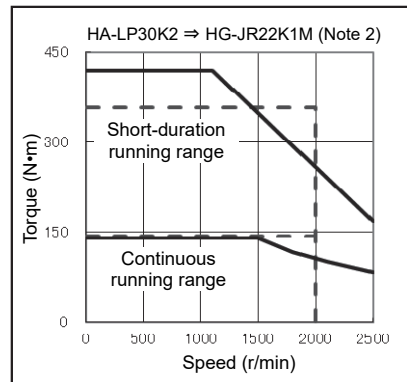
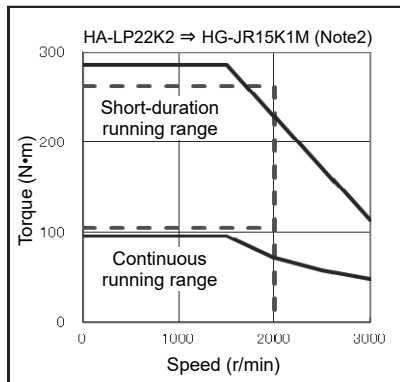
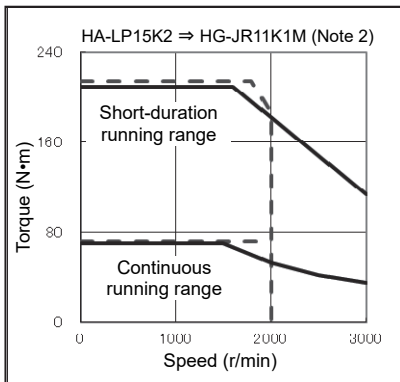
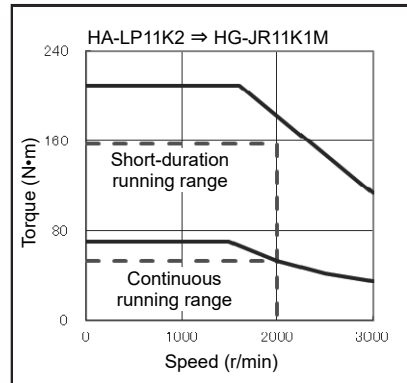
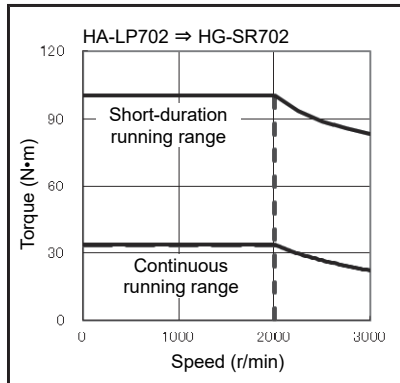
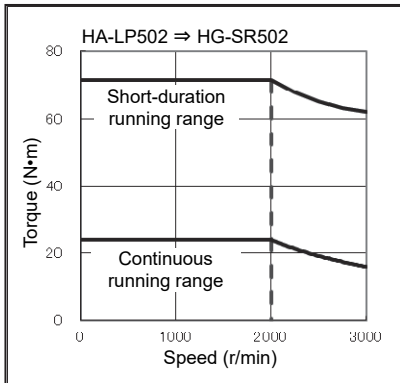

- Note 1. The above torque characteristics are for 3-phase 200 V AC.
 Note 2. Please contact your local sales office if the compatibility of torque characteristics is required.

Part 9: Review on Replacement of Motor

(f) HA-LP 2000 r/min series 400 V class

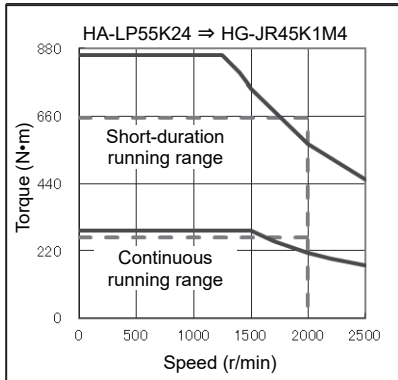
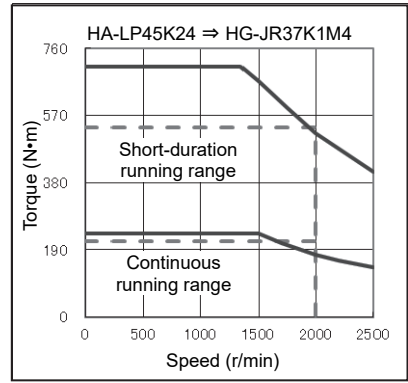
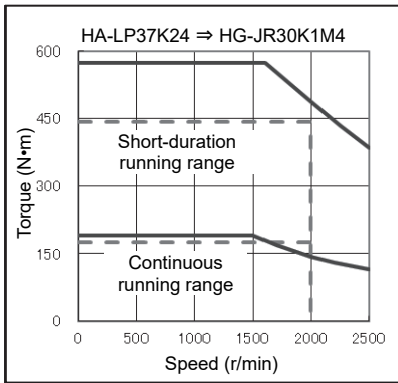
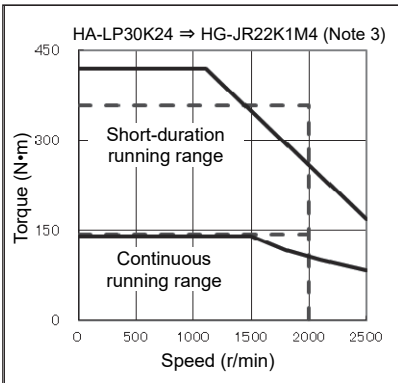
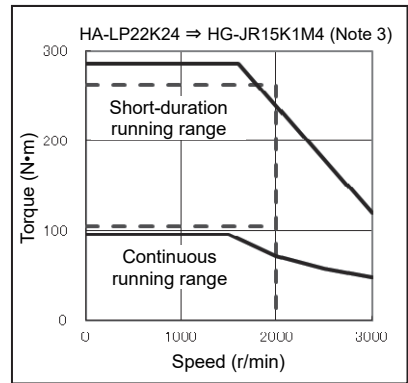
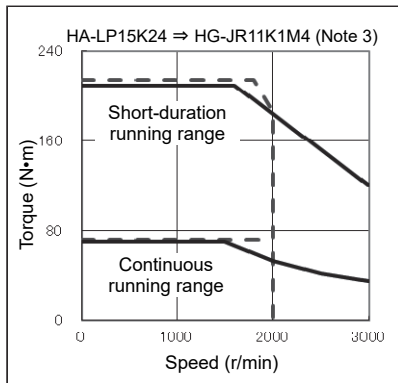
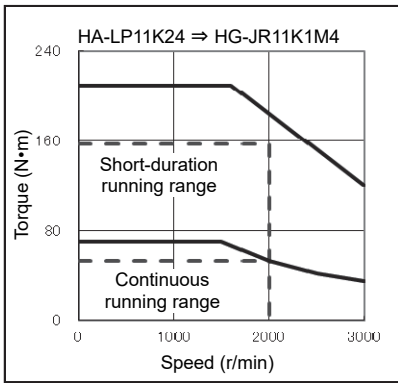

- Note
1. The above torque characteristics are for 3-phase 400V AC.
 2. As for 3-phase 380V AC, refer to the catalog or instruction manual.
 3. Please contact your local sales office if the compatibility of torque characteristics is required.

Part 10
Review on Replacement of
Optional Peripheral
Equipment

Part 10: Review on Replacement of Optional Peripheral Equipment

Part 10: Review on Replacement of Optional Peripheral Equipment

1. COMPARISON TABLE OF REGENERATIVE OPTION COMBINATIONS

POINT
<ul style="list-style-type: none"> ● The MR-J4 series provides the new regenerative options shown in the table below. ● When an MR-J3/MR-J3W series regenerative resistor is used as it is with a motor combined, an alarm may occur. Use the MR-J4 series in combination with the regenerative resistor for MR-J4 series. ● Do not use regenerative options newly provided by the MR-J4 series with the MR-J3/MR-J3W series because use of them causes a servo amplifier malfunction.

List of new regenerative options

Servo amplifier model	Regenerative option MR-RB		Accessory regenerative resistor
MR-J4-350_(-RJ)	3N	5N	
MR-J4-11K_(-RJ)	5R		GRZG400-0.8Ω × 4
MR-J4-15K_(-RJ)	9F		GRZG400-0.6Ω × 5
MR-J4-22K_(-RJ)	9T		GRZG400-0.5Ω × 5
MR-J4-700_4(-RJ)	3U-4	5U-4	
MR-J4-11K_4(-RJ)	5K-4		GRZG400-2.5Ω × 4
MR-J4-15K_4(-RJ)	6K-4		GRZG400-2Ω × 5
MR-J4-DU30K_4 MR-J4-DU37K_4 MR-J4-DU45K_4 MR-J4-DU55K_4	137-4	13V-4	
MR-J4W2-77B MR-J4W2-1010B	3N		

Part 10: Review on Replacement of Optional Peripheral Equipment

1.1 Regenerative Options 200 V class /100 V class

1.1.1 Combination and regenerative power for the MR-J3/MR-J3W series

List of regenerative options

Servo amplifier model	Built-in regenerative resistor [W]	Permissible regenerative power of regenerative option [W] MR-RB								
		032 [40 Ω]	12 [40 Ω]	30 [13 Ω]	3N [9 Ω]	31 [6.7 Ω]	32 [40 Ω]	(Note 1) 50 [13 Ω]	(Note 1) 5N [9 Ω]	(Note 1) 51 [6.7 Ω]
MR-J3-10_(1)		30								
MR-J3-20_(1)	10	30	100							
MR-J3-40_(1)	10	30	100							
MR-J3-60_	10	30	100							
MR-J3-70_	20	30	100				300			
MR-J3-100_	20	30	100				300			
MR-J3-200_(N)(-RT)	100			300				500		
MR-J3-350_	100			300				500		
MR-J3-500_	130					300				500
MR-J3-700_	170					300				500

Servo amplifier model	Built-in regenerative resistor [W]	(Note 2) Standard accessories [External]	Permissible regenerative power of regenerative option [W] MR-RB							139 [1.3 Ω]	(Note 3) 137 [1.3 Ω]
			(Note 2) 5E [6 Ω]	(Note 2) 5R [3.2 Ω]	(Note 2) 9P [4.5 Ω]	(Note 2) 9F [3 Ω]	(Note 2) 9T [2.5 Ω]				
MR-J3-11K_		GRZG400-1.5Ω × 4 500 (800)	500 (800)								
MR-J3-11K_-LR		GRZG400-0.8Ω × 4 500 (800)		500 (800)							
MR-J3-15K_		GRZG400-0.9Ω × 5 850 (1300)			850 (1300)						
MR-J3-15K_-LR		GRZG400-0.6Ω × 5 850 (1300)				850 (1300)					
MR-J3-22K_						850 (1300)					
MR-J3-DU30K_									1300	3900	
MR-J3-DU37K_									1300	3900	

Note 1. Always install a cooling fan.

2. The values in the parentheses are applied to when a cooling fan is installed.

3. This values are the resultant resistance of three MR-RB137.

Servo amplifier model	Built-in regenerative resistor [W]	Permissible regenerative power of regenerative option [W] MR-RB		
		14 [26 Ω]	34 [26 Ω]	3B [20 Ω]
MR-J3W-22B	10	100		
MR-J3W-44B		100		
MR-J3W-77B	100		300	
MR-J3W-1010B				300
MR-J3W-0303BN6 (Note)	1.3			

Note. MR-J3W-0303BN6 servo amplifier is not compatible with regenerative option.

Part 10: Review on Replacement of Optional Peripheral Equipment

1.1.2 Combination and regenerative power for MR-J4 series (replacement model)

POINT
● Changed items are shown with shading.
● Parameter settings may be required depending on the regenerative option model.

List of regenerative options

Servo amplifier model	Built-in regenerative resistor [W]	Permissible regenerative power of regenerative option [W] MR-RB								
		032 [40 Ω]	12 [40 Ω]	30 [13 Ω]	3N [9 Ω]	31 [6.7 Ω]	32 [40 Ω]	(Note 1) 50 [13 Ω]	(Note 1) 5N [9 Ω]	(Note 1) 51 [6.7 Ω]
MR-J4-10_(1)(-RJ)		30								
MR-J4-20_(1)(-RJ)	10	30	100							
MR-J4-40_(1)(-RJ)	10	30	100							
MR-J4-60_(-RJ)	10	30	100							
MR-J4-70_(-RJ)	20	30	100				300			
MR-J4-100_(-RJ)	20	30	100				300			
MR-J4-200_(-RJ)	100			300				500		
MR-J4-350_(-RJ)	100				300				500	
MR-J4-500_(-RJ)	130					300				500
MR-J4-700_(-RJ)	170					300				500

Servo amplifier model	Built-in regenerative resistor [W]	(Note 2) Standard accessories [External]	Permissible regenerative power of regenerative option [W] MR-RB							
			(Note 2) 5E [6 Ω]	(Note 2) 5R [3.2 Ω]	(Note 2) 9P [4.5 Ω]	(Note 2) 9F [3 Ω]	(Note 2) 9T [2.5 Ω]	139 [1.3 Ω]	(Note 3) 137 [1.3 Ω]	
MR-J4-11K_(-RJ)		GRZG400-0.8Ω × 4 500 (800)		500 (800)						
MR-J4-15K_(-RJ)		GRZG400-0.6Ω × 5 850 (1300)				850 (1300)				
MR-J4-22K_(-RJ)		GRZG400-0.5Ω × 5 850 (1300)					850 (1300)			
MR-J4-DU30K_									1300	3900
MR-J4-DU37K_									1300	3900

Note 1. Always install a cooling fan.

Note 2. The values in the parentheses are applied to when a cooling fan is installed.

Note 3. This values are the resultant resistance of three MR-RB137.

Servo amplifier model	Built-in regenerative resistor [W]	Permissible regenerative power of regenerative option [W] MR-RB	
		14 [26 Ω]	3N [9 Ω]
MR-J4W2-22B	20	100	
MR-J4W2-44B		100	
MR-J4W2-77B	100		300
MR-J4W2-1010B			300
MR-J4W2-0303B6 (Note)	1.3		

Note. MR-J4W2-0303B6 servo amplifier is not compatible with regenerative option.

Part 10: Review on Replacement of Optional Peripheral Equipment

1.1.3 External Form Comparison

	MR-J3/MR-J3W series	MR-J4 series
350_	<p>MR-RB30/MR-RB31/MR-RB34/MR-RB3B</p> <p>Cooling fan mounting screw (2-M4 screw)</p> <p>Air intake</p>	<p>MR-RB30/MR-RB31/MR-RB34/MR-RB3N</p> <p>Cooling fan mounting screw (2-M4 screw)</p> <p>Intake</p>
350_	<p>MR-RB50/MR-RB51</p> <p>Cooling fan mounting screw (2-M3 screw) On opposite side</p> <p>7×14 slot</p> <p>Air intake</p>	<p>MR-RB50/MR-RB51/MR-RB5N</p> <p>Cooling fan mounting screw (2-M3 screw) On opposite side</p> <p>7 × 14 slotted hole</p> <p>Intake</p>
11K_ 15K_ 22K_	<p>MR-RB5E/MR-RB9P/MR-RB9F</p> <p>2-φ10 mounting hole</p> <p>Cooling fan mounting screw 4-M3 screw</p>	<p>MR-RB5R/MR-RB9F/MR-RB9T</p> <p>2-φ10 mounting hole</p> <p>Screw for mounting cooling fan 4-M3 screw</p>

Part 10: Review on Replacement of Optional Peripheral Equipment

1.2 Regenerative Options 400 V class

1.2.1 Combination and regenerative power for the MR-J3 series

List of regenerative options

Servo amplifier model	Built-in regenerative resistor [W]	Permissible regenerative power of regenerative option [W] MR-RB							
		1H-4 [82 Ω]	(Note 1) 3M-4 [120 Ω]	(Note 1) 3G-4 [47 Ω]	(Note 1) 34-4 [26 Ω]	(Note 1) 3U-4 [22 Ω]	(Note 1) 5G-4 [47 Ω]	(Note 1) 54-4 [26 Ω]	(Note 1) 5U-4 [22 Ω]
MR-J3-60_4	15	100	300						
MR-J3-100_4	15	100	300						
MR-J3-200_4	100			300			500		
MR-J3-350_4	100			300			500		
MR-J3-500_4	130				300			500	
MR-J3-700_4	170				300			500	

Servo amplifier model	Built-in regenerative resistor [W]	(Note 2) Standard accessories [External]	Permissible regenerative power of regenerative option [W] MR-RB						
			(Note 2) 5K-4 [10 Ω]	(Note 2) 6B-4 [20 Ω]	(Note 2) 60-4 [12.5 Ω]	(Note 2) 6K-4 [10 Ω]	136-4 [5 Ω]	(Note3) 138-4 [5 Ω]	
MR-J3-11K_4		GRZG400-5Ω × 4 500(800)		500 (800)					
MR-J3-11K_4-LR		GRZG400-2.5Ω × 4 500 (800)		500 (800)					
MR-J3-15K_4		GRZG400-2.5Ω × 5 850 (1300)			850 (1300)				
MR-J3-15K_4-LR		GRZG400-2Ω × 5 850 (1300)				850 (1300)			
MR-J3-22K_4						850 (1300)			
MR-J3-DU30K_4							1300	3900	
MR-J3-DU37K_4							1300	3900	
MR-J3-DU45K_4							1300	3900	
MR-J3-DU55K_4							1300	3900	

Note 1. Always install a cooling fan.

2. The values in the parentheses are applied to when a cooling fan is installed.

3. The composite resistor value of three options is 5 Ω. The resistor value of one option is 15 Ω.

Part 10: Review on Replacement of Optional Peripheral Equipment

1.2.2 Combination and regenerative power for MR-J4 series (replacement model)

POINT
● Changed items are shown with shading.
● Parameter settings may be required depending on the regenerative option model.

List of regenerative options

Servo amplifier model	Built-in regenerative resistor [W]	Permissible regenerative power of regenerative option [W] MR-RB							
		1H-4 [82 Ω]	(Note 1) 3M-4 [120 Ω]	(Note 1) 3G-4 [47 Ω]	(Note 1) 34-4 [26 Ω]	(Note 1) 3U-4 [22 Ω]	(Note 1) 5G-4 [47 Ω]	(Note 1) 54-4 [26 Ω]	(Note 1) 5U-4 [22 Ω]
MR-J4-60_4(-RJ)	15	100	300						
MR-J4-100_4(-RJ)	15	100	300						
MR-J4-200_4(-RJ)	100			300			500		
MR-J4-350_4(-RJ)	100			300			500		
MR-J4-500_4(-RJ)	130				300			500	
MR-J4-700_4(-RJ)	170					300			500

Servo amplifier model	Built-in regenerative resistor [W]	(Note 2) Standard accessories [External]	Permissible regenerative power of regenerative option [W] MR-RB						
			(Note 2) 5K-4 [10 Ω]	(Note 2) 6B-4 [20 Ω]	(Note 2) 60-4 [12.5 Ω]	(Note 2) 6K-4 [10 Ω]	137-4 [4 Ω]	(Note 3) 13V-4 [4 Ω]	
MR-J4-11K_4(-RJ)		GRZG400-2.5Ω × 4 500 (800)	500 (800)						
MR-J4-15K_4(-RJ)		GRZG400-2.0Ω × 5 850 (1300)				850 (1300)			
MR-J4-22K_4(-RJ)		GRZG400-2.0Ω × 5 850 (1300)				850 (1300)			
MR-J4-DU30K_4							1300	3900	
MR-J4-DU37K_4							1300	3900	
MR-J4-DU45K_4							1300	3900	
MR-J4-DU55K_4							1300	3900	

Note 1. Always install a cooling fan.

2. The values in the parentheses are applied to when a cooling fan is installed.

3. The composite resistor value of three options is 4 Ω. The resistor value of one option is 12 Ω.

Part 10: Review on Replacement of Optional Peripheral Equipment

1.2.3 External Form Comparison

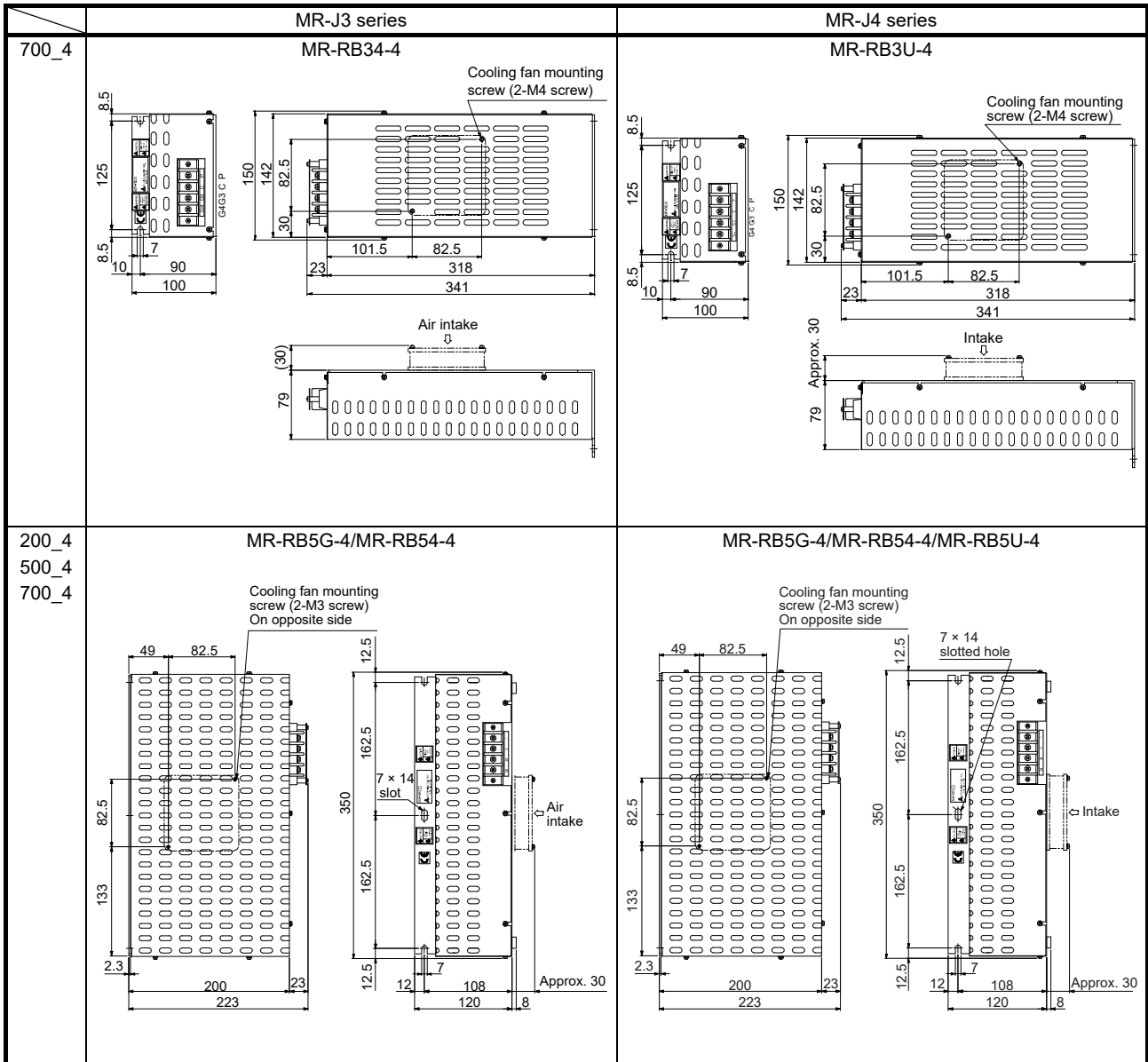

Part 10: Review on Replacement of Optional Peripheral Equipment

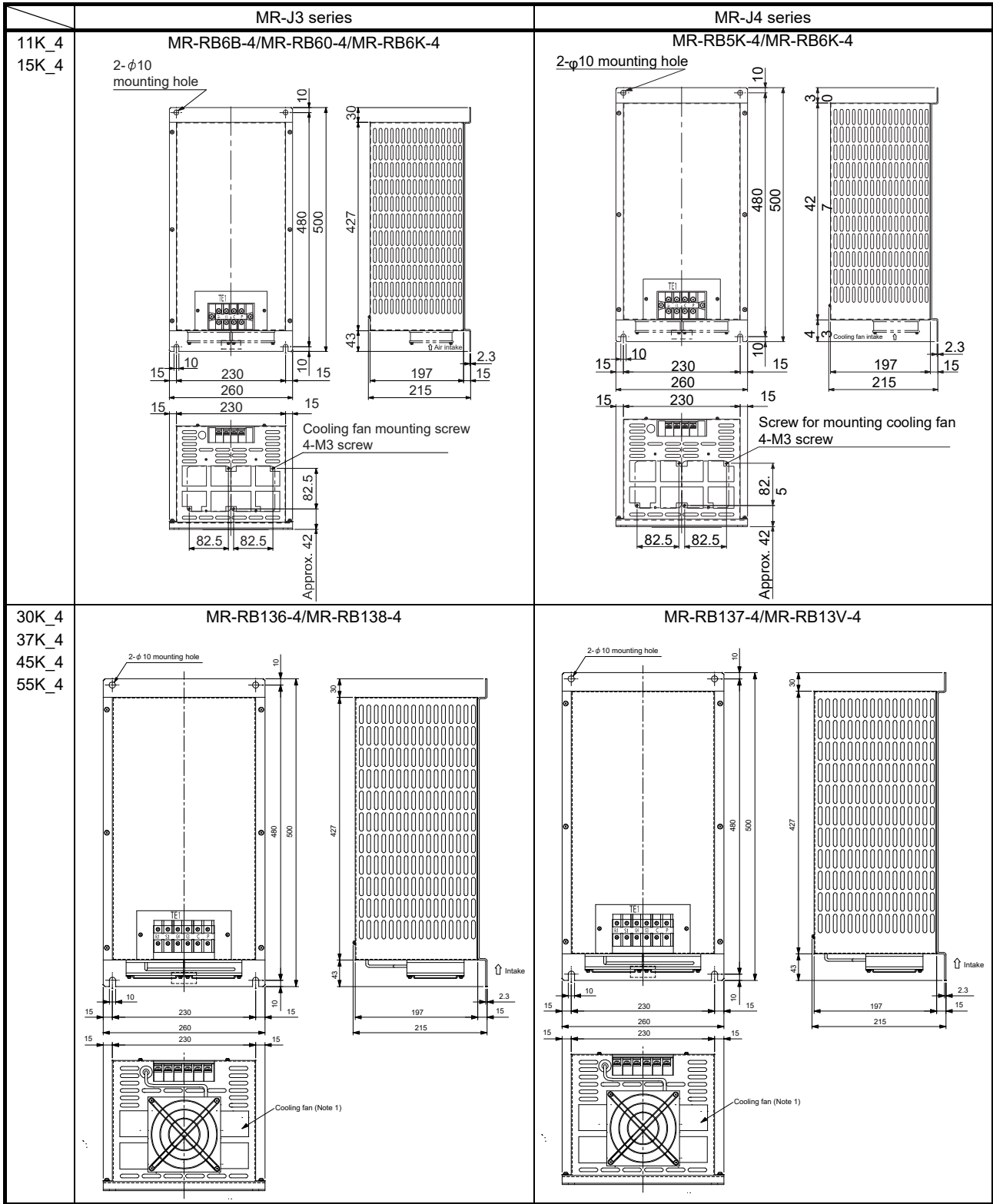

Note 1. One cooling fan for MR-RB136-4/MR-RB138-4/MR-RB137-4/MR-RB13V-4.

Part 10: Review on Replacement of Optional Peripheral Equipment

2. COMPARISON TABLE OF DYNAMIC BRAKE OPTION COMBINATIONS

POINT
<ul style="list-style-type: none"> ● When an MR-J4-22K(-RJ) servo amplifier and an HG-JR22K1M servo motor are combined, the coasting distance will be longer. Therefore, use a dynamic brake option, DBU-22K-R1. ● Changed items are shown with shading.

Dynamic brake option combination

Model	Applicable servo amplifier	
DBU-11K	MR-J3-11K_	MR-J4-11K_(-RJ)
DBU-15K	MR-J3-15K_	MR-J4-15K_(-RJ)
DBU-22K	MR-J3-22K_	
DBU-22K-R1		MR-J4-22K_(-RJ)
DBU-37K	MR-J3-DU30K_ MR-J3-DU37K	
DBU-37K-R1		MR-J4-DU30K_ MR-J4-DU37K_
DBU-11K-4	MR-J3-11K_4	MR-J4-11K_4(-RJ)
DBU-22K-4	MR-J3-15K_4 MR-J3-22K_4	MR-J4-15K_4(-RJ) MR-J4-22K_4(-RJ)
DBU-55K-4	MR-J3-DU30K_4 MR-J3-DU37K_4 MR-J3-DU45K_4 MR-J3-DU55K_4	
DBU-55K-4-R5		MR-J4-DU30K_4 MR-J4-DU37K_4 MR-J4-DU45K_4 MR-J4-DU55K_4

Part 10: Review on Replacement of Optional Peripheral Equipment

2.1 External Form Comparison

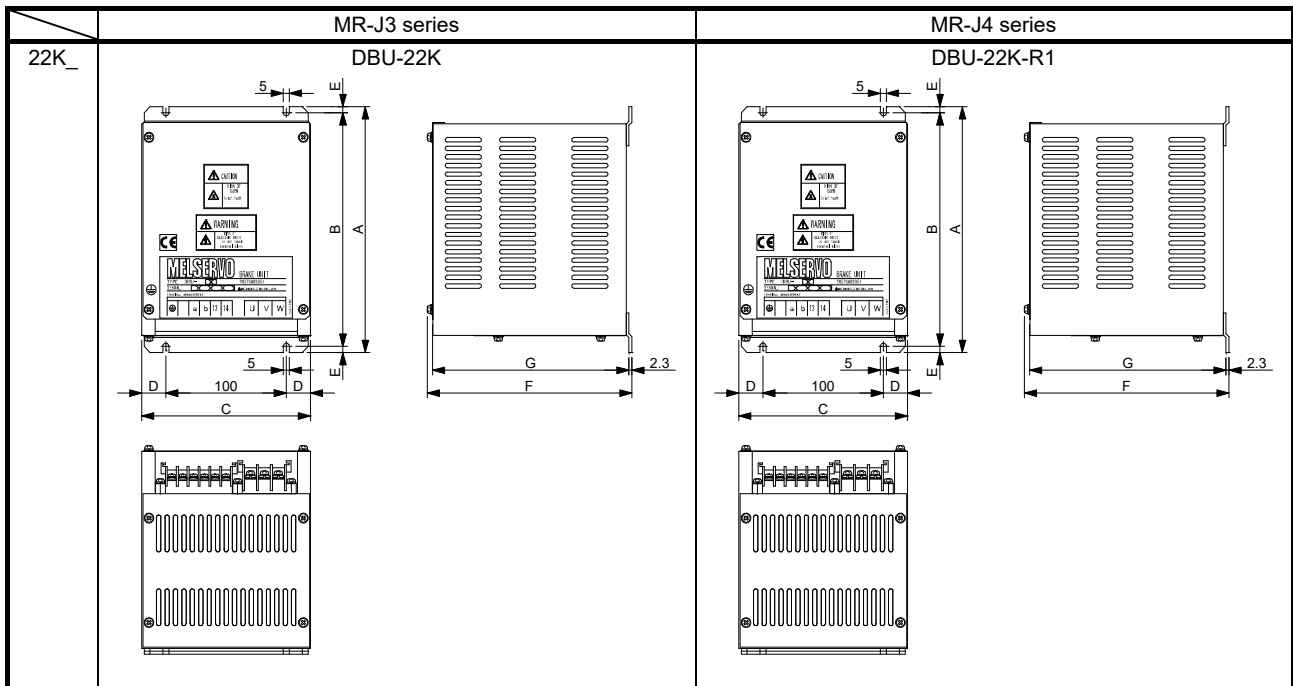

External dynamic brake	A	B	C	D	E	F	G	Mass [kg]
DBU-22K	250	238	150	25	6	235	228	6
DBU-22K-R1	250	238	150	25	6	235	228	6

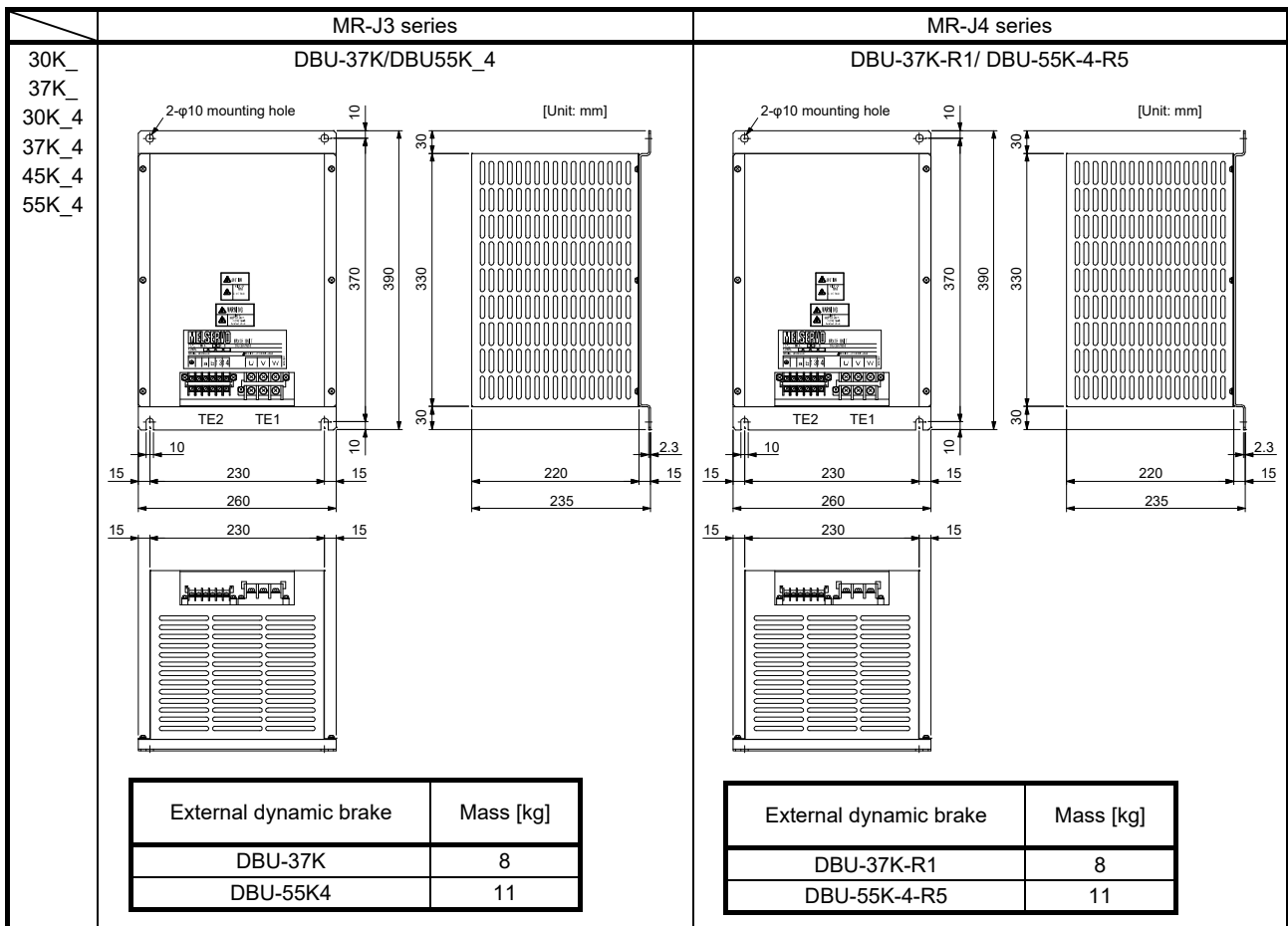

External dynamic brake	Mass [kg]
DBU-37K	8
DBU-55K4	11

External dynamic brake	Mass [kg]
DBU-37K-R1	8
DBU-55K-4-R5	11

Part 10: Review on Replacement of Optional Peripheral Equipment

3. COMPARISON TABLE OF CABLE OPTION COMBINATIONS

3.1 Changes from MR-J3 series to MR-J4 series

Cable option combinations

Application		MR-J3 series	MR-J4 series	Compatibility (Note 6)	Note
Encoder cable		MR-J3ENCBL_M-A_-		○	Use the same combination. _M: Cable length A_: Leading direction -_: Bending life
		MR-J3JCBL03M-A_-L		○	
		MR-EKCBL_M-		○	
		MR-J3JSCBL03M-A_-L		○	
		MR-J3ENSCBL_M-		○	
Encoder cable		MR-ENECBL_M-H	MR-ENECBL_M-H	(Note 1)	Use the same cables for the models other than the ones shown below. It is required when using 15 kW or more HG-JR 1000 r/min series or 22 kW or more HG-JR 1500 r/min series. _: Cable length
			MR-ENECBL_M-H-MTH		
Encoder connector set		MR-ECNM		○	Use the same combination.
		MR-J3SCNS	MR-J3SCNS	(Note 1)	Use the same cables for the models other than the ones shown below.
			MR-ENECNS	(Note 1)	It is required when using 15 kW or more HG-JR 1000 r/min series or 22 kW or more HG-JR 1500 r/min series.
			MR-ENCNS2	○	The screw-type is added.
		MR-J3SCNSA	MR-J3SCNSA	○	Use the same combination.
			MR-ENCNS2A	○	The screw-type is added.
		MR-ENECNS	○	Use the same combination.	
SSCNET optical communication cable		MR-J3BUS_M		○	Use the same combination.
		MR-J3BUS_M_-		○	_M: Cable length -_: Bending life
Connector set for SSCNET optical communication		MR-J3BCN1		○	Use the same combination.
Junction terminal block cable	General-Purpose interface CN1	MR-J2M-CN1TBL_M		○	Use the same combination. _: Cable length
connector set		MR-J3CN1		○	Use the same combination.
Junction terminal block		MR-TB50		○	Use the same combination.
Junction terminal block cable	SSCNET interface CN3	MR-J2HBUS_M		○	Use the same combination. _: Cable length
connector set		MR-CCN1		○	Use the same combination.
Junction terminal block cable	DIO command / Serial communication operation CN6	MR-TBNATBL_M	MR-J2M-CN1TBL_M	×	Newly required. For CN1 of MR-J4-_A_-RJ _: Cable length
connector set		MR-J2CMP2	MR-J3CN1	×	
Junction terminal block		MR-TB26A	MR-TB50	×	
Junction terminal block cable	CC-Link communication operation CN6		MR-J2HBUS_M	×	Newly required. For CN3 of MR-J4-_GF_- _: Cable length
connector set		MR-J2CMP2	MR-CCN1	×	
Junction terminal block			PS7DW-20V14B-F (Recommended product)	×	
Servo motor power supply cable		MR-PWS1CBL_M-A_-		○	Use the same combination.
		MR-PWS2CBL03M-A_-L		○	_M: Cable length A_: Leading direction -_: Bending life

Part 10: Review on Replacement of Optional Peripheral Equipment

Application	MR-J3 series	MR-J4 series	Compatibility (Note 6)	Note	
Power connector set (Servo motor side power connector)	MR-PWCNS4		○	Use the same combination.	
	MR-PWCNS5		○		
	MR-PWCNS3		○		
	MR-PWCNS1		○		
	MR-PWCNS2		○		
Electromagnetic brake cable	MR-BKS1CBL_M-A_-		○	Use the same combination. _M: Cable length _A_: Leading direction -_ : Bending life	
	MR-BKS2CBL03M-A_-L		○		
Electromagnetic brake connector set	MR-BKCNS1	MR-BKCNS1	○	Use the same combination.	
		MR-BKCNS2	○	The screw-type is added.	
	MR-BKCNS1A	MR-BKCNS1A	○	Use the same combination.	
		MR-BKCNS2A	○	The screw-type is added.	
	MR-BKCN		○	Use the same combination.	
Servo amplifier power connector (1 kW or less)	CNP1	54928-0670	06JFAT-SAXGDK-H7.5	(Note 2)	Connector shape is changed because the manufacturer is changed. () is for MR-J3-200_(-RT).
	CNP2	54927-0520	05JFAT-SAXGDK-H5.0	(Note 2)	
	CNP3	54928-0370	03JFAT-SAXGDK-H7.5	(Note 2)	
Servo amplifier power connector (2 kW)	CNP1	721-207/026-000 (PC4/6-STF-7.62-CRWH)	06JFAT-SAXGFK-XL	(Note 2)	
	CNP2	721-205/026-000 (54927-0520)	05JFAT-SAXGDK-H5.0	(Note 2)	
	CNP3	721-203/026-000 (PC4/3-STF-7.62-CRWH)	03JFAT-SAXGFK-XL	(Note 2)	
Servo amplifier power connector (3.5 kW)	CNP1	PC4/6-STF-7.62-CRWH	06JFAT-SAXGFK-XL	(Note 2)	
	CNP2	54927-0520	05JFAT-SAXGDK-H5.0	(Note 2)	
	CNP3	PC4/3-STF-7.62-CRWH	03JFAT-SAXGFK-XL	(Note 2)	
CN5 communication cable	MR-J3USBCBL3M		○	Use the same combination.	
Battery for junction battery cable	MR-J3BTCBL03M	MR-BT6VCBL03M	(Note 3)	Use the dedicated battery of each series.	
Monitor cable	MR-J3CN6CBL1M		○	Use the same combination. When MR-J3-_T_ is replaced, prepare a new one.	
Protection coordination cable (30 kW or more)	MR-J3CDL05M		○	Use the same combination.	
CN40/CN40A connector set	MR-J2CN1-A		○	Use the same combination.	
Termination connector	MR-J3-TM		○	Not required	
Magnetic contactor wiring connector	(Note 4)		○	Use the same combination. Socket: GFKC 2.5/2-STF-7.62	
Digital I/O connector			○	Use the same combination. connector: 17JE23090-02(D8A)K11-CG	
STO cable		MR-D05UDL3M-B	(Note 5)	When not using the STO function, attach the short-circuit connector came with the servo amplifier to CN8.	

- Note 1. When using 15 kW or more HG-JR 1000 r/min series or 22 kW or more HG-JR 1500 r/min series, replace with the MR-ENECBL_M-H-MTH cable or MR-ENECNS connector set.
2. These replacement models do not have compatibility in mounting. The power connector is supplied with a servo amplifier for MR-J4 series. Replace the existing connectors with the ones supplied with the servo amplifier.
3. Use the dedicated battery of each series.
4. Supplied with converter unit.
5. MR-D05UDL3M-B is in production.
6. ○: Compatible, △: Compatible with condition, ×: Not compatible

Part 10: Review on Replacement of Optional Peripheral Equipment

3.2 Changes from MR-J3W series to MR-J4W2-_B Servo amplifier

Cable option combinations

Application		MR-J3W series	MR-J4W2-B Servo amplifier	Compatibility (Note 3)	Note
Encoder cable		MR-J3ENCBL_M-A_-		○	Use the same combination. _M: Cable length _A_: Leading direction -_ : Bending life
		MR-J3JCBL03M-A_-L		○	
		MR-EKCBL_M_-		○	
		MR-J3JSCBL03M-A_-L		○	
		MR-J3ENSCBL_M_-		○	
Encoder connector set		MR-ECNM		○	Use the same combination
		MR-J3SCNS		○	Use the same combination
		MR-J3SCNSA		○	Use the same combination
SSCNET optical communication cable		MR-J3BUS_M		○	Use the same combination _M: Cable length -_ : Bending life
		MR-J3BUS_M_-		○	
Connector set for SSCNET optical communication		MR-J3BCN1		○	Use the same combination
Junction terminal block cable	SSCNET III/H interface CN3	MR-TBNATBL_M		○	Use the same combination _M: Cable length
connector set		MR-J2CMP2		○	
		MR-ECN1		○	
Servo motor power supply cable		MR-PWS1CBL_M-A_-		○	Use the same combination _M: Cable length _A_: Leading direction -_ : Bending life
		MR-PWS2CBL03M-A_-L		○	
Power connector set (Servo motor side power connector)		MR-PWCNS1		○	Use the same combination
		MR-PWCNS4		○	
		MR-PWCNS5		○	
Electromagnetic brake cable		MR-BKS1CBL_M-A_-		○	Use the same combination _M: Cable length _A_: Leading direction -_ : Bending life
		MR-BKS2CBL03M-A_-L		○	
Electromagnetic brake connector set		MR-BKCNS1		○	Use the same combination
		MR-BKCNS1A		○	Use the same combination
Servo amplifier power connector	CNP1	For MR-J3WCNP123- SP connector set CNP1 : 03JFAT-AXGFK-43 CNP2 : 06JFAT-SAXYGG-F-KK CNP3A/3B : 04JFAT-SAGG-G-KK	03JFAT-SAXGFK-43 (Note 1)	△	Replace the existing connectors with the ones supplied with the servo amplifier.
	CNP2		06JFAT-SAXYGG-F-KK (Note 1)	△	
	CNP3A/CNP3B		04JFAT-SAGG-G-KK (Note 1)	△	
CN5 communication cable		MR-J3USBCBL3M		○	Use the same combination
Encoder cable		MR-J3W03ENCBL_M-A-H		○	<DC 48 V/24 V model> Use the same combination. _M: Cable length
Encoder connector set		MR-J3W03CN2-2P		○	<DC 48 V/24 V model>
		MR-J3W03CN2-20P		○	Use the same combination.
Servo motor power cable	MR-J3W03PWCBL_M-A-H	MR-J4W03PWCBL_M-A-H	(Note2)	<DC 48 V/24 V model>	
	MR-J3W03PWBCBL_M-A-H	MR-J4W03PWBCBL_M-A-H	(Note2)	_M: Cable length -_ : Bending life	
Power connector set	MR-J3W03CNP2-2P	MR-J4W03CNP2-2P	(Note2)	<DC 48 V/24 V model>	
	MR-J3W03CNP2-20P	MR-J4W03CNP2-20P	(Note2)		

Note 1. These replacement models do not have compatibility in mounting. The power connector is supplied with a servo amplifier for MR-J4W2-_B servo amplifier.

2. These replacement models do not have compatibility in mounting. The power connector is supplied with a servo amplifier for MR-J4 series.

3. ○: Compatible, △: Compatible with condition, ×: Not compatible

Part 10: Review on Replacement of Optional Peripheral Equipment

4. POWER SUPPLY WIRE SIZE

4.1 Selection of Power Supply Wire Size (Example)

4.1.1 MR-J3 series power supply wire size

POINT
<ul style="list-style-type: none">● Wires indicated in this section are separated wires. When using a cable for power line (U/V//W) between the servo amplifier and servo motor, use a 600 V grade EP rubber insulated chloroprene sheath cab-tire cable (2PNCT). For selection of cables, refer to each servo amplifier instruction manual.● To comply with the UL/C-UL (CSA) Standard, use the wires shown in the servo amplifier for wiring. To comply with other standards, use a wire that is complied with each standard.● Selection condition of wire size is as follows. Construction condition: One wire is constructed in the air Wire length: 30 m or less

Part 10: Review on Replacement of Optional Peripheral Equipment

(1) Wires for power supply wiring

POINT
<p>● Use 600 V Grade heat-resistant polyvinyl chloride insulated wires (HIV wires) for HF-JP series servo motor.</p>

The following diagram shows the wires used for wiring. Use the wires given in this section or equivalent.

In this case, the power supply wire used is a 600 V plastic one and the wiring distance is 30 m or less. When the wiring distance exceeds 30 m, select another wire size in consideration of the voltage drop. The alphabet letters (a/b/c) on the table correspond to crimp terminals used when wiring a servo amplifier.

The method of wiring a servo motor differs depending on the type and capacity of the servo motor. To comply with the UL/cUL (CSA) standard, use UL-approved copper wires rated at 60°C or higher for wiring.

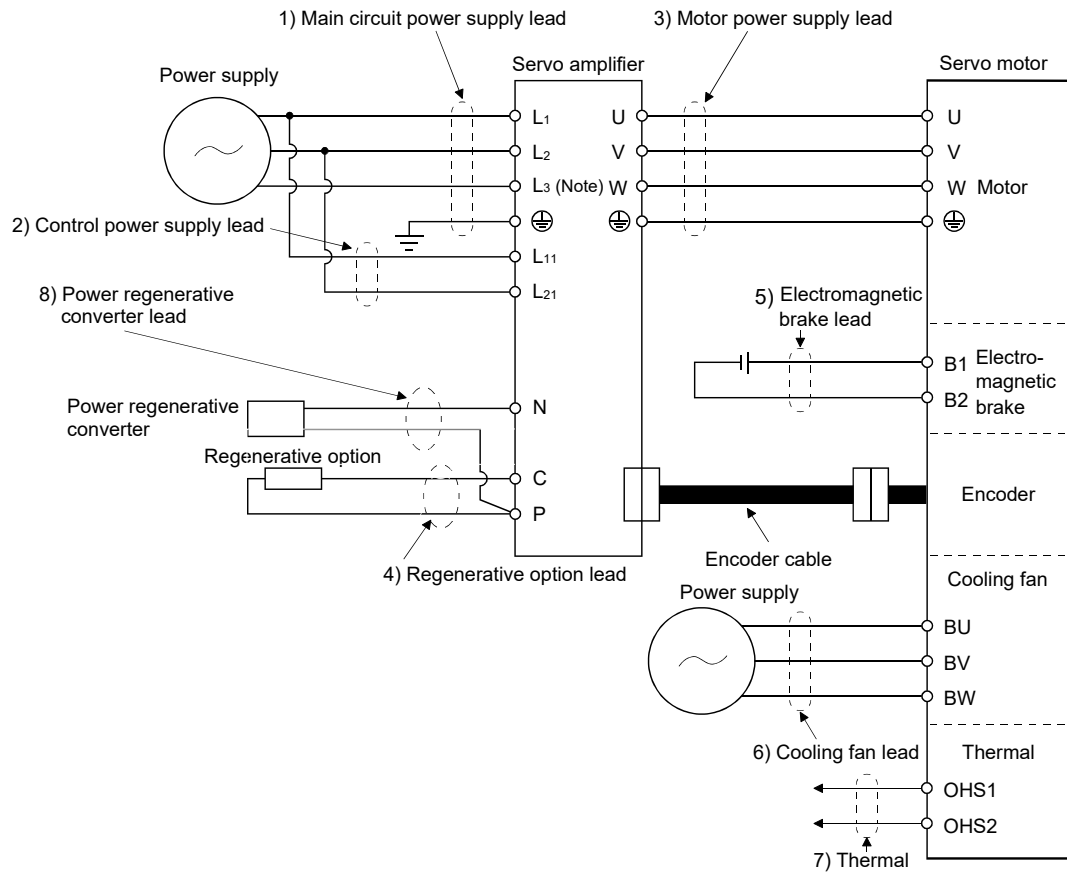

Note There is no L₃ for 1-phase 100 to 120 V AC power supply.

Part 10: Review on Replacement of Optional Peripheral Equipment

Wire size selection example 1 (IV wire) Recommended wire

Servo amplifier	Power supply wire [mm ²] (Note 1, 4)														
	1) L1/L2/L3/⊕	2) L11/L21	3) U/V/W/⊕	4) P/C	5) B1/B2	6) BU/BV/BW	7) OHS1/OHS2								
MR-J3-10_(1)	2 (AWG14)	1.25 (AWG16)	1.25 (AWG16)	2 (AWG14)	1.25 (AWG16)	/	/								
MR-J3-20_(1)															
MR-J3-40_(1)															
MR-J3-60_			2 (AWG14)												
MR-J3-70_															
MR-J3-100_															
MR-J3-200_			3.5 (AWG12)												
MR-J3-350_															
MR-J3-500_ (Note 2)	1.25 (AWG16): h	5.5 (AWG10): a		2 (AWG14): g											
MR-J3-700_ (Note 2)		8 (AWG8): b	8 (AWG8): b	3.5 (AWG12): a		2 (AWG14) (Note 3)	1.25 (AWG16) (Note 3)								
MR-J3-11K_ (Note 2)	14 (AWG6): c	1.25 (AWG16): g	22 (AWG4): d	5.5 (AWG10): j		1.25 (AWG16)	/	/							
MR-J3-15K_ (Note 2)	22 (AWG4): d		30 (AWG2): e						5.5 (AWG10): k	2 (AWG14)	1.25 (AWG16)				
MR-J3-22K_ (Note 2)	50 (AWG1/0): f		60 (AWG2/0): f	5.5 (AWG10): k								2 (AWG14)	1.25 (AWG16)		
MR-J3-60_4	2 (AWG14)	1.25 (AWG16)	1.25 (AWG16)				2 (AWG14)	1.25 (AWG16)	/	/					
MR-J3-100_4			2 (AWG14)												
MR-J3-200_4															
MR-J3-350_4	2 (AWG14): g	1.25 (AWG16): h	2 (AWG14): g	2 (AWG14): g			1.25 (AWG16)		/	/					
MR-J3-500_4 (Note 2)											5.5 (AWG10): a	5.5 (AWG10): a	2 (AWG14): g	2 (AWG14) (Note 3)	1.25 (AWG16) (Note 3)
MR-J3-700_4 (Note 2)															
MR-J3-11K_4 (Note 2)	8 (AWG8): l	1.25 (AWG16): g	8 (AWG8): l	3.5 (AWG12): j					1.25 (AWG16)	/	/				
MR-J3-15K_4 (Note 2)	14 (AWG6): c		22 (AWG4): d	5.5 (AWG10): j	2 (AWG14)							1.25 (AWG16)			
MR-J3-22K_4 (Note 2)	14 (AWG6): m		22 (AWG4): n	5.5 (AWG10): k											

Note 1. Alphabets in the table indicate crimping tools. For crimping terminals and applicable tools, refer to Section 4.2.1 of this document.

2. When connecting to the terminal block, be sure to use the screws which are provided with the terminal block.
3. For the servo motor with a cooling fan.
4. Wires are selected based on the highest rated current among combining servo motors.

Part 10: Review on Replacement of Optional Peripheral Equipment

Wire size selection example (HIV wire)

Servo amplifier	Power supply wire [mm ²] (Note 1, 4)							
	1) L1/L2/L3/⊕	2) L11/L21	3) U/V/W/⊕	4) P/C	5) B1/B2	6) BU/BV/BW	7) OHS1/OHS2	
MR-J3-10_(1)	2 (AWG14)	1.25 (AWG16)	1.25 (AWG16)	2 (AWG14)	1.25 (AWG16)			
MR-J3-20_(1)								
MR-J3-40_(1)								
MR-J3-60_			1.25 (AWG16)					
MR-J3-70_								
MR-J3-100_								
MR-J3-200_			2 (AWG14)					
MR-J3-350_	3.5 (AWG12)	3.5 (AWG12)						
MR-J3-500_ (Note 2)	5.5 (AWG10): a	1.25 (AWG16): h	5.5 (AWG10): a	2 (AWG14): g				
MR-J3-700_ (Note 2)	8 (AWG8): b		8 (AWG8): b	2 (AWG14): g		1.25 (AWG16) (Note 3)	1.25 (AWG16) (Note 3)	
MR-J3-11K_ (Note 2)	14 (AWG6): c	1.25 (AWG16): g	14 (AWG6): c	3.5 (AWG12): j		1.25 (AWG16)	1.25 (AWG16)	1.25 (AWG16)
MR-J3-15K_ (Note 2)	22 (AWG4): d		22 (AWG4): d					
MR-J3-22K_ (Note 2)	38 (AWG1): p		38 (AWG1): p	5.5 (AWG10): k				
MR-J3-60_4	2 (AWG14)	1.25 (AWG16)	1.25 (AWG16)	2 (AWG14)				
MR-J3-100_4			2 (AWG14)					
MR-J3-200_4								
MR-J3-350_4	2 (AWG14): g	1.25 (AWG16): h	2 (AWG14): g	2 (AWG14): g				
MR-J3-500_4 (Note 2)			3.5 (AWG12): a					
MR-J3-700_4 (Note 2)			5.5 (AWG10): a			1.25 (AWG16) (Note 3)	1.25 (AWG16) (Note 3)	
MR-J3-11K_4 (Note 2)	5.5 (AWG10): j	1.25 (AWG16): g	8 (AWG8): l	2 (AWG14): q	1.25 (AWG16)	1.25 (AWG16)		
MR-J3-15K_4 (Note 2)	8 (AWG8): l		14 (AWG6): c	3.5 (AWG12): j				
MR-J3-22K_4 (Note 2)	14 (AWG6): m		14 (AWG6): m	3.5 (AWG12): k				

Note 1. Alphabets in the table indicate crimping tools. For crimping terminals and applicable tools, refer to Section 4.2.1 of this document.

2. To connect these models to a terminal block, make sure to use the screws that come with the terminal block.

3. For the servo motor with a cooling fan.

4. Wires are selected based on the highest rated current among combining servo motors.

Part 10: Review on Replacement of Optional Peripheral Equipment

4.1.2 MR-J4 series power supply wire size

POINT
● To comply with the IEC/EN/UL/CSA standard, use the wires shown in the instruction manuals of the servo amplifier in use for wiring. To comply with other standards, use a wire that is complied with each standard.
● Selection conditions of wire size are as follows. Construction condition: Single wire set in midair Wire length: 30 m or less

The following diagram shows the wires used for wiring. Use the wires given in this section or equivalent.

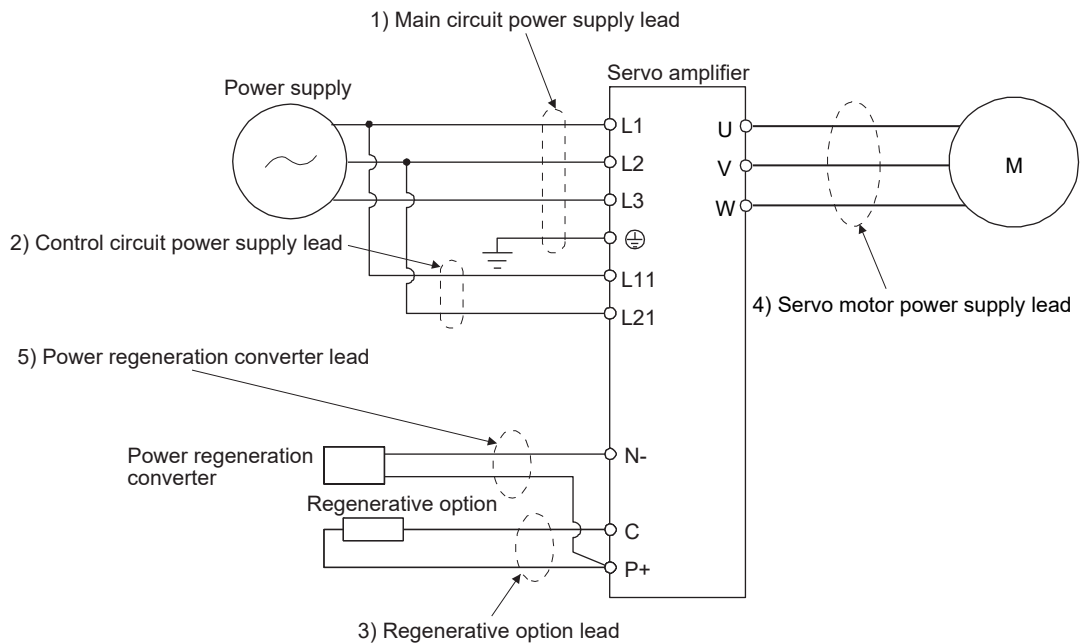

Part 10: Review on Replacement of Optional Peripheral Equipment

(1) Example of selecting the wire sizes

POINT
● Use the HIV wire for the replacement with MR-J4.

For the power supply wire, use a 600 V grade heat-resistant polyvinyl chloride insulated wire (HIV wire). The table below shows selection examples of power supply wire sizes.

Wire size selection example (HIV wire)
Recommended wire

Servo amplifier	Power supply wire [mm ²] (Note 1)			
	1) L1/L2/L3/⊕	2) L11/L21	3) P+/C	4) U/V/W/⊕ (Note 3)
MR-J4-10_(1) (-RJ)	2 (AWG 14)	1.25 to 2 (AWG 16 to 14) (Note 4)	2 (AWG 14)	AWG 18 to 14 (Note 4)
MR-J4-20_(1) (-RJ)				
MR-J4-40_(1) (-RJ)				
MR-J4-60_(-RJ)				
MR-J4-70_(-RJ)				
MR-J4-100_(-RJ)				
MR-J4-200_(-RJ)				
MR-J4-350_(-RJ)	3.5 (AWG 12)			AWG 16 to 10
MR-J4-500_(-RJ) (Note 2)	5.5 (AWG 10): a	1.25 (AWG 16): a 2 (AWG 14): d (Note 4)	2 (AWG 14): c	2 (AWG 14): c 3.5 (AWG 12): a 5.5 (AWG 10): a
MR-J4-700_(-RJ) (Note 2)	8 (AWG 8): b			2 (AWG 14): c 3.5 (AWG 12): a 5.5 (AWG 10): a 8 (AWG 8): b
MR-J4-11K_(-RJ) (Note 2)	14 (AWG 6): f	1.25 (AWG 16): c 2 (AWG 14): c	3.5 (AWG 12): g	14 (AWG 6): f 5.5 (AWG 10): g 8 (AWG 8): k
MR-J4-15K_(-RJ) (Note 2)	22 (AWG 4): h		5.5 (AWG 10): g	22 (AWG 4): h 8 (AWG 8): k
MR-J4-22K_(-RJ) (Note 2)	38 (AWG 2): i		5.5 (AWG 10): j	38 (AWG 2): i
MR-J4-60_4(-RJ)/ MR-J4-100_4(-RJ)	2 (AWG 14)	1.25 to 2 (AWG 16 to 14) (Note 4)	2 (AWG 14)	AWG 16 to 14
MR-J4-200_4(-RJ)				
MR-J4-350_4(-RJ)				
MR-J4-500_4(-RJ) (Note 2)	2 (AWG 14): b	1.25 (AWG 16): a 2 (AWG 14): c (Note 4)	2 (AWG 14): b	3.5 (AWG 12): a
MR-J4-700_4(-RJ) (Note 2)	3.5 (AWG 12): a			5.5 (AWG 10): a
MR-J4-11K_4(-RJ) (Note 2)	5.5 (AWG 10): d	1.25 (AWG 16): b 2 (AWG 14): b (Note 4)	2 (AWG 14): f	8 (AWG 8): g
MR-J4-15K_4(-RJ) (Note 2)	8 (AWG 8): g		3.5 (AWG 12): d	
MR-J4-22K_4(-RJ) (Note 2)	14 (AWG 6): i		3.5 (AWG 12): e	5.5 (AWG 10): e 8 (AWG 8): h 14 (AWG 6): i

- Note 1. Alphabets in the table indicate crimping tools. For crimp terminals and applicable tools, refer to 4.2.2 (1), (2) of this document.
2. To connect these models to a terminal block, make sure to use the screws that come with the terminal block.
3. This wire size is applicable to the servo amplifier connector and terminal block. For wires connecting to the servo motor, refer to "HG-MR/HG-KR/HG-SR/HG-JR/HG-RR/HG-UR/HG-AK Servo Motor Instruction Manual (Vol. 3)".
4. To comply with the IEC/EN/UL/CSA standard, use a wire of 2 mm².

Part 10: Review on Replacement of Optional Peripheral Equipment

4.1.3 MR-J3W series power supply wire size

POINT
● Wires indicated in this section are separated wires.
● To comply with the UL/CSA Standard, use the wires shown in appendix 4 for wiring. To comply with other standards, use a wire that is complied with each standard.
● Selection condition of wire size is as follows. Construction condition: One wire is constructed in the air Wire length: 30 m or less

(1) 200 V class wires for power supply wiring

The following diagram shows the wires used for wiring. Use the wires given in this section or equivalent.

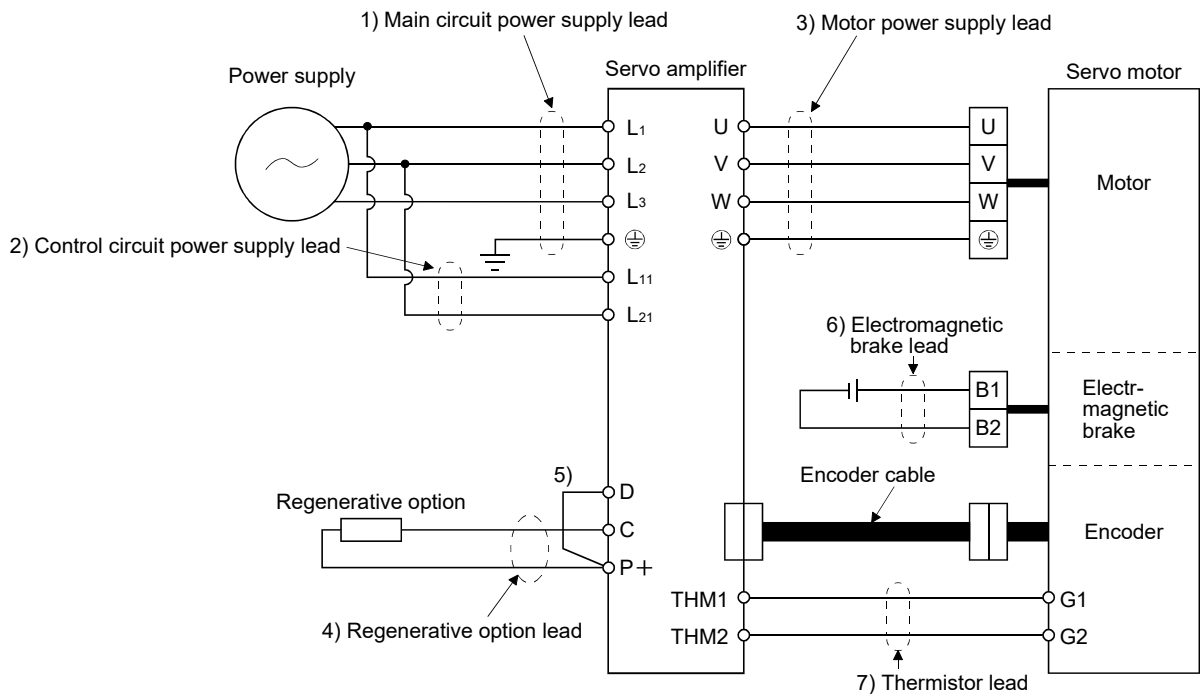

The following table shows selection examples of cable sizes. These sizes are common for the 600V Polyvinyl chloride insulated wire (IV wire) and for the 600V Grade heat-resistant polyvinyl chloride insulated wire (HIV wire).

Wire size selection example 1 (IV/HIV wire)

Servo amplifier	Wires [mm ²] (Note 1)						
	1) L ₁ /L ₂ /L ₃ /⊕ (Note 3)	2) L ₁₁ /L ₂₁	3) U/V/W/ ⊕ (Note 2, 3)	4) P+/C	5) P+/D	6) B ₁ /B ₂ (Note 2)	7) THM1/THM2
MR-J3W-22B	2 (AWG14)					1.25 (AWG16)	0.2 (AWG24)
MR-J3W-44B	2 (AWG14)					1.25 (AWG16)	0.2 (AWG24)
MR-J3W-77B	2 (AWG14)					1.25 (AWG16)	0.2 (AWG24)
MR-J3W-1010B	2 (AWG14)					1.25 (AWG16)	0.2 (AWG24)

- Note
1. Wires are selected based on the highest rated current among combining servo motors.
 2. This wire size indicates the size of cable extension which is used when the wiring length exceeds 10 m.
 3. Use the crimping terminal specified as below for the PE terminal of the servo amplifier.
Crimping terminal : FVD2-4
Tool (body) : YNT-1614
Manufacturer : JST (J.S.T. Mfg. Co.,Ltd.)
Tightening torque : 1.2 [N·m]

Part 10: Review on Replacement of Optional Peripheral Equipment

(2) DC 48 V/24 V class wires for power supply wiring

The following diagram shows the wires used for wiring. Use the wires or equivalent given in this section. These sizes are common for the 600V Polyvinyl chloride insulated wire (IV wire) and for the 600V Grade heat-resistant polyvinyl chloride insulated wire (HIV wire).

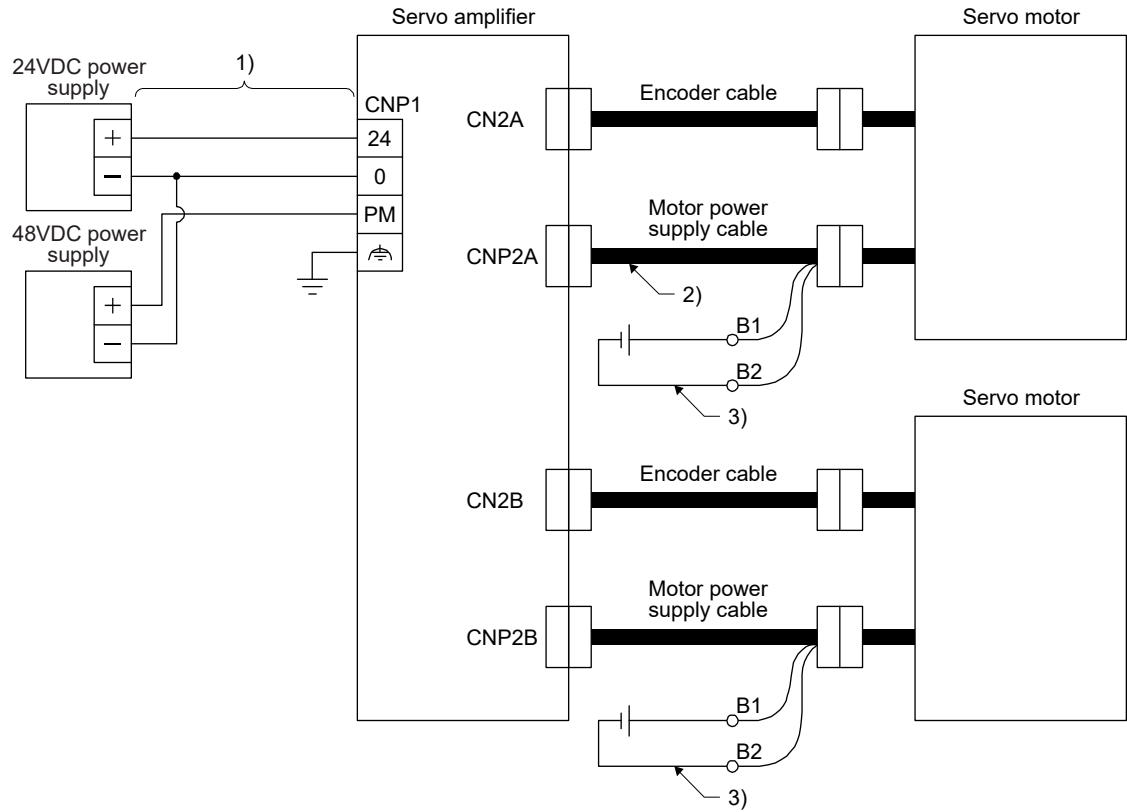

Wire size selection example (IV/HIV wire)

Servo amplifier	Wire (Note 1)		
	1) 24/0/PM/⏏	2) U/V/W/⏏	3) B1/B2
MR-J3W-0303BN6	AWG16 (Note 2, 3)	AWG19	1.25 mm ² (AWG16)

- Note
1. This is a selection example when HG-AK0336(B) are used for two axes.
 2. Insulator OD: 2.9 mm
 3. Voltage drop will occur according to line impedance and current supplied to the servo amplifier. Be sure to use this wire.

Part 10: Review on Replacement of Optional Peripheral Equipment

4.1.4 MR-J4W2-_B servo amplifier, power supply wire size

POINT
<ul style="list-style-type: none"> ● To comply with the IEC/EN/UL/CSA standard, use the wires shown in servo amplifier instruction manual for wiring. To comply with other standards, use a wire that is complied with each standard. ● Selection conditions of wire size are as follows. Construction condition: One wire is constructed in the air Wire length: 30 m or less

(1) 200 V class wires for power supply wiring

The following diagram shows the wires used for wiring. Use the wires given in this section or equivalent.

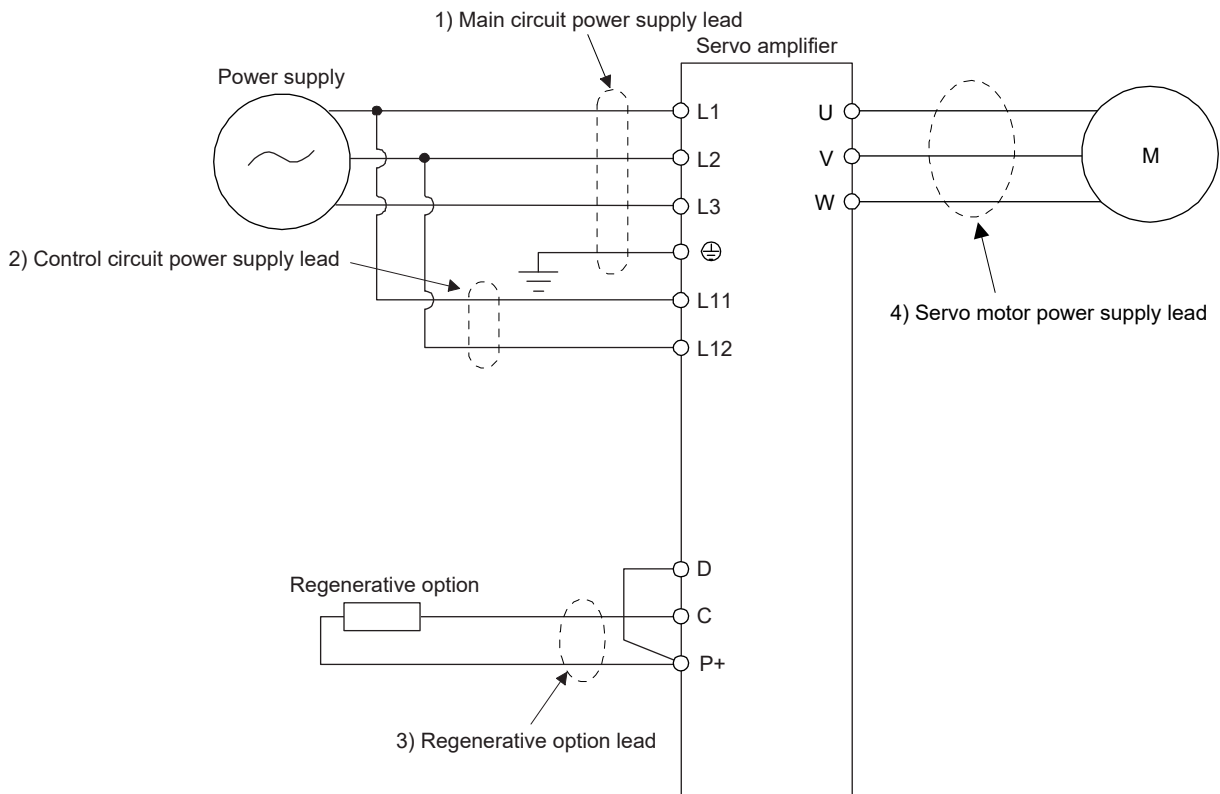

The following table shows the wire size selection example.

Wire size selection example (HIV wire)

Servo amplifier	Wires [mm ²]			
	1) L1/L2/L3/⊕ (Note 1)	2) L11/L21	3) P+/C/D	4) U/V/W/⊕ (Note 2)
MR-J4W2-22B	2 (AWG 14)			AWG 18 to 14
MR-J4W2-44B				
MR-J4W2-77B				
MR-J4W2-1010B				

Note 1. Use the crimp terminal specified as below for the PE terminal of the servo amplifier.

Crimp terminal: FVD2-4

Tool: YNT-1614

Manufacturer: JST (J.S.T. Mfg. Co.,Ltd.)

Tightening torque: 1.2 [N•m]

2. The wire size shows applicable size of the servo amplifier connector. For wires connecting to the servo motor, refer to "HG-MR/HG-KR/HG-SR/HG-JR/HG-RR/HG-UR/HG-AK Servo Motor Instruction Manual (Vol. 3)".

Part 10: Review on Replacement of Optional Peripheral Equipment

(2) DC 48 V/24 V class wires for power supply wiring

The following diagram shows the wires used for wiring. Use the wires or equivalent given in this section.

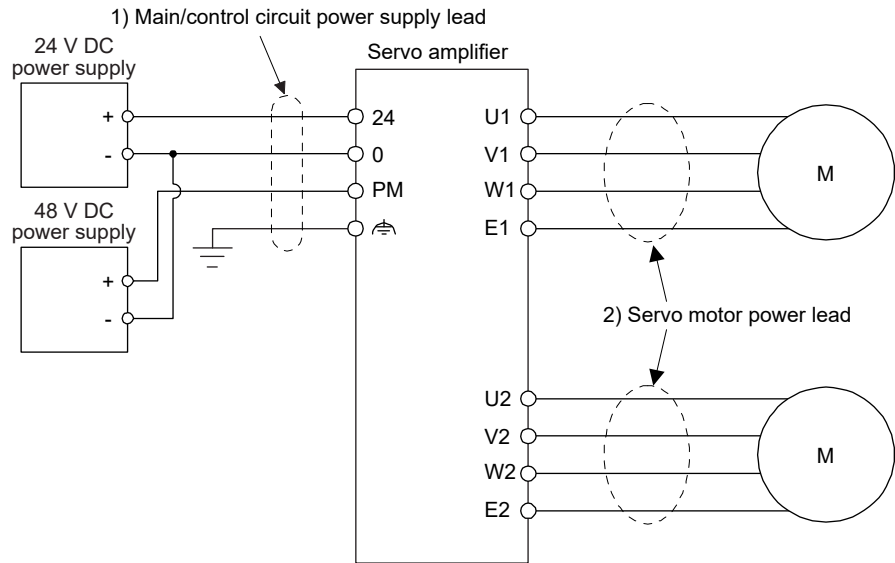

The following shows the wire size selection example.

Wire size selection example (HIV wire)

Servo amplifier	Wire [mm ²]	
	1) 24/0/PM/⏏	2) U1/V1/W1/E1/U2/V2/W2/E2 (Note)
MR-J4W2-0303B6	AWG 16	AWG 19

Note. The wire size shows applicable size of the servo amplifier connector. For wires connecting to the servo motor, refer to "HG-MR/HG-KR/HG-SR/HG-JR/HG-RR/HG-UR/HG-AK Servo Motor Instruction Manual (Vol. 3)".

Part 10: Review on Replacement of Optional Peripheral Equipment

4.2 Selection Example of Crimp Terminals

4.2.1 MR-J3 series crimp terminal

Recommended crimp terminals

Symbol	Servo amplifier-side crimp terminals				Manufacturer
	Crimp terminal (Note 2)	Applicable tool			
		Body	Head	Dice	
a	FVD5.5-4	YNT-1210S			JST (J.S.T. Mfg. Co., Ltd.)
b (Note 1)	8-4NS	YHT-8S			
c	FVD14-6	YF-1	YNE-38	DH-122 DH-112	
d	FVD22-6	E-4		DH-123 DH-113	
e (Note 1)	38-6	YPT-60-21	YET-60-1	TD-124 TD-112	
		YF-1 E-4			
f (Note 1)	R60-8	YPT-60-21	YET-60-1	TD-125 TD-113	
		YF-1 E-4			
g	FVD2-4	YNT-1614			
h	FVD2-M3				
j	FVD5.5-6				
k	FVD5.5-8	YNT-1210S			
l	FVD8-6	YF-1 E-4	YNE-38	DH-121 DH-111	
m	FVD14-8			DH-122 DH-112	
n	FVD22-8			DH-123 DH-113	
p (Note 1)	R38-8	YPT-60-21	YET-60-1	TD-124 TD-112	
		YF-1 E-4			
q	FVD2-6	YNT-1614			

- Note 1. Coat the crimping part with an insulation tube.
 Note 2. Some crimp terminals may not be mounted depending on the size. Make sure to use the recommended ones or equivalent ones.

Part 10: Review on Replacement of Optional Peripheral Equipment

4.2.2 MR-J4 series crimp terminal

(1) Selection example of crimp terminals 200 V class/100 V class

The table below shows selection examples of a crimp terminal for a servo amplifier terminal block.

Recommended crimp terminals

Symbol	Servo amplifier-side crimp terminals				Manufacturer
	Crimp terminal (Note 2)	Applicable tool			
		Body	Head	Dice	
a	FVD5.5-4	YNT-1210S			JST (J.S.T. Mfg. Co., Ltd.)
b (Note 1)	8-4NS	YHT-8S			
c	FVD2-4	YNT-1614			
d	FVD2-M3				
e	FVD1.25-M3	YNT-2216			
f	FVD14-6	YF-1	YNE-38	DH-122 DH-112	
g	FVD5.5-6	YNT-1210S			
h	FVD22-6	YF-1	YNE-38	DH-123 DH-113	
i	FVD38-8	YF-1	YNE-38	DH-124 DH-114	
j	FVD5.5-8	YNT-1210S			
k	FVD8-6	YF-1 E-4	YNE-38	DH-121 DH-111	

Note 1. Cover the crimped portion with an insulating tape.

2. Installation of a crimp terminal may be impossible depending on the size, so make sure to use the recommended crimp terminal or one equivalent to it.

(2) Selection example of crimp terminals 400 V class

The table below shows selection examples of a crimp terminal for a servo amplifier terminal block.

Recommended crimp terminals

Symbol	Servo amplifier-side crimp terminals				Manufacturer	
	Crimp terminal (Note)	Applicable tool				
		Body	Head	Dice		
a	FVD5.5-4	YNT-1210S			JST (J.S.T. Mfg. Co., Ltd.)	
b	FVD2-4	YNT-1614				
c	FVD2-M3					
d	FVD5.5-6	YNT-1210S				
e	FVD5.5-8	YNT-1210S				
f	FVD2-6	YNT-1614				
g	FVD8-6	YF-1	YNE-38	DH-121 DH-111		
h	FVD8-8					
i	FVD14-8					DH-122 DH-112

Note. Installation of a crimp terminal may be impossible depending on the size, so make sure to use the recommended crimp terminal or one equivalent to it.

Part 10: Review on Replacement of Optional Peripheral Equipment

4.3 Selection of Molded-Case Circuit Breaker, Fuse, and Magnetic Contactor (Example)

4.3.1 MR-J3 series, molded-case circuit breakers, fuses, and magnetic contactors



CAUTION

- Select a molded-case circuit breaker with a short shut-off time to prevent smoking and fire from the servo amplifier.
- Always use one molded-case circuit breaker and one magnetic contactor with one servo amplifier.

When using a fuse instead of the molded-case circuit breaker, use the one having the specifications given in this section.

Molded-case circuit breakers, fuses, and magnetic contactors

Servo amplifier	Molded-case circuit breaker (Note 3)		Voltage AC	Fuse			Magnetic contactor (Note 2)
	Current			Class (Note 1)	Current	Voltage AC	
	Not using power factor improving reactor	Using power factor improving reactor					
MR-J3-10_(1)	30 A frame 5 A	30 A frame 5 A	240 V	T	10 A	300 V	S-N10
MR-J3-20_	30 A frame 5 A	30 A frame 5 A			10 A		
MR-J3-20_1	30 A frame 10 A	30 A frame 10 A			15 A		
MR-J3-40_	30 A frame 10 A	30 A frame 5 A			15 A		
MR-J3-60_/70_/100_/40_1	30 A frame 15 A	30 A frame 10 A			20 A		
MR-J3-200_	30 A frame 20 A	30 A frame 15 A			40 A		
MR-J3-350_	30 A frame 30 A	30 A frame 30 A			70 A		
MR-J3-500_	50 A frame 50 A	50 A frame 40 A			125 A		
MR-J3-700_	100 A frame 75 A	50 A frame 50 A			150 A		
MR-J3-11K_	100 A frame 100 A	100 A frame 75 A			200 A		
MR-J3-15K_	225 A frame 125 A	100 A frame 100 A			250 A		
MR-J3-22K_	225 A frame 175 A	225 A frame 150 A			350 A		
MR-J3-60_4	30 A frame 5 A	30 A frame 5 A	600 Y/347 V	T	10 A	600 V	S-N10
MR-J3-100_4	30 A frame 10 A	30 A frame 10 A			15 A		
MR-J3-200_4	30 A frame 15 A	30 A frame 15 A			25 A		
MR-J3-350_4	30 A frame 20 A	30 A frame 20 A			35 A		
MR-J3-500_4	30 A frame 30 A	30 A frame 30 A			50 A		
MR-J3-700_4	50 A frame 40 A	50 A frame 30 A			65 A		
MR-J3-11K_4	60 A frame 60 A	50 A frame 50 A			100 A		
MR-J3-15K_4	100 A frame 75 A	60 A frame 60 A			150 A		
MR-J3-22K_4	225 A frame 125 A	100 A frame 100 A			175 A		
MR-J3-22K_4	225 A frame 125 A	100 A frame 100 A			175 A		

- Note
1. When not using the servo amplifier as a UL/CSA Standard compliant product, K5 class fuse can be used.
 2. Be sure to use a magnetic contactor with an operation delay time of 80 ms or less.
 3. Use a molded-case circuit breaker which has the same or more operation characteristics than our lineup.

Part 10: Review on Replacement of Optional Peripheral Equipment

4.3.2 MR-J4 series, molded-case circuit breakers, fuses, and magnetic contactors (recommended)

(1) For main circuit power supply

 CAUTION	<ul style="list-style-type: none"> ● Select a molded-case circuit breaker with a short shut-off time to prevent smoking and fire from the servo amplifier.
	<ul style="list-style-type: none"> ● Always use one molded-case circuit breaker and one magnetic contactor with one servo amplifier.
	<ul style="list-style-type: none"> ● Since recommended products vary between MR-J3 and MR-J4, use the recommended products of MR-J4-__.

When using a fuse instead of the molded-case circuit breaker, use the one having the specifications given in this section.

Molded-case circuit breakers, fuses, and magnetic contactors

Servo amplifier	Molded-case circuit breaker (Note 1)			Fuse			Magnetic contactor (Note 2)
	Frame, rated current		Voltage AC [V]	Class	Current [A]	Voltage AC [V]	
	Power factor improving reactor is not used	Power factor improving reactor is used					
MR-J4-10_(-RJ)	30 A frame 5 A	30 A frame 5 A	240	T	10	300	S-N10 S-T10
MR-J4-20_(-RJ)							
MR-J4-20_1(-RJ)	30 A frame 10 A	30 A frame 10 A			15		
MR-J4-40_(-RJ)	30 A frame 10 A	30 A frame 5 A					
MR-J4-60_(-RJ)	30 A frame 15 A	30 A frame 10 A			20		
MR-J4-70_(-RJ)							
MR-J4-40_1(-RJ)							
MR-J4-100_(-RJ) (3-phase power supply input)							
MR-J4-100_(-RJ) (1-phase power supply input)	30 A frame 15 A	30 A frame 15 A			30		
MR-J4-200_(-RJ)	30 A frame 20 A	30 A frame 20 A			40		
MR-J4-350_(-RJ)	30 A frame 30 A	30 A frame 30 A			70		S-N20 S-T21
MR-J4-500_(-RJ)	50 A frame 50 A	50 A frame 50 A			125		S-N35
MR-J4-700_(-RJ)	100 A frame 75 A	60 A frame 60 A			150		S-N50
MR-J4-11K_(-RJ)	100 A frame 100 A	100 A frame 100 A			200		
MR-J4-15K_(-RJ)	125 A frame 125 A	125 A frame 125 A			250		S-N65
MR-J4-22K_(-RJ)	225 A frame 175 A	225 A frame 175 A			350		S-N95
MR-J4-60_4(-RJ)	30 A frame 5 A	30 A frame 5 A	480	T	600	S-N10 S-T10	
MR-J4-100_4(-RJ)	30 A frame 10 A	30 A frame 5 A					10
MR-J4-200_4(-RJ)	30 A frame 15 A	30 A frame 10 A					15
MR-J4-350_4(-RJ)	30 A frame 20 A	30 A frame 15 A					25
MR-J4-500_4(-RJ)	30 A frame 20 A	30 A frame 20 A				35	S-N20 (Note 3) S-T21
MR-J4-700_4(-RJ)	30 A frame 30 A	30 A frame 30 A				50	S-N20 S-T21
MR-J4-11K_4(-RJ)	50 A frame 50 A	50 A frame 50 A				65	S-N25
MR-J4-15K_4(-RJ)	60 A frame 60 A	60 A frame 60 A				100	S-N35
MR-J4-22K_4(-RJ)	100 A frame 100 A	100 A frame 100 A				150	S-N50
						175	

- Note 1. In order for the servo amplifier to comply with the UL/CSA standard, refer to the applicable "Servo amplifier instruction manual".
2. Use a magnetic contactor with an operation delay time (interval between current being applied to the coil until closure of contacts) of 80 ms or less.
3. S-N18 can be used when auxiliary contact is not required.

Part 10: Review on Replacement of Optional Peripheral Equipment

(2) For control circuit power supply

When the wiring for the control circuit power supply (L11, L21) is thinner than that for the main circuit power supply (L1, L2, L3), install an overcurrent protection device (molded-case circuit breaker or fuse) to protect the branch circuit.

Molded-case circuit breaker, fuse

Servo amplifier	Molded-case circuit breaker (Note)		Fuse (Class T)		Fuse (Class K5)	
	Frame, rated current	Voltage AC [V]	Current [A]	Voltage AC [V]	Current [A]	Voltage AC [V]
MR-J4-10_(-RJ)	30 A frame 5 A	240	1	300	1	250
MR-J4-20_(-RJ)						
MR-J4-40_(-RJ)						
MR-J4-60_(-RJ)						
MR-J4-70_(-RJ)						
MR-J4-100_(-RJ)						
MR-J4-200_(-RJ)						
MR-J4-350_(-RJ)						
MR-J4-500_(-RJ)						
MR-J4-700_(-RJ)						
MR-J4-11K_(-RJ)						
MR-J4-15K_(-RJ)						
MR-J4-22K_(-RJ)						
MR-J4-60_4(-RJ)	30 A frame 5 A	480	1	600	1	600
MR-J4-100_4(-RJ)						
MR-J4-200_4(-RJ)						
MR-J4-350_4(-RJ)						
MR-J4-500_4(-RJ)						
MR-J4-700_4(-RJ)						
MR-J4-11K_4(-RJ)						
MR-J4-15K_4(-RJ)						
MR-J4-22K_4(-RJ)						
MR-J4-10_1(-RJ)	30 A frame 5 A	240	1	300	1	250
MR-J4-20_1(-RJ)						
MR-J4-40_1(-RJ)						

Note. In order for the servo amplifier to comply with the UL/CSA standard, refer to each servo amplifier instruction manual.

Part 10: Review on Replacement of Optional Peripheral Equipment

4.3.3 MR-J3W series, no-fuse breakers, fuses, magnetic contactors

Always use one molded-case circuit breaker and one magnetic contactor with one servo amplifier. When using a fuse instead of the molded-case circuit breaker, use the one having the specifications given in this section.

When using two different types of motors in combination from a rotary servo motor, a select a molded-case circuit breaker, a fuse or a magnetic contactor temporarily assuming that the same type of the motors are used for both axes. After selecting for the two types, use the larger molded-case circuit breaker, fuse or magnetic contactor.

Total output of rotary servo motor	Molded-case circuit breaker		Voltage AC [V]	Fuse			Magnetic contactor (Note 2)
	Current			Class (Note 1)	Current [A]	Voltage AC [V]	
	Not using power factor improving AC reactor	Using power factor improving AC reactor					
300 W or less	30 A frame 5 A	30 A frame 5 A	240	K5	15	300	S-N10
From over 300 W to 600 W	30 A frame 10 A	30 A frame 10 A			20		
From over 600 W to 1 kW	30 A frame 15 A	30 A frame 10 A			20		
From over 1 kW to 2 kW	30 A frame 20 A	30 A frame 15 A			30		
							S-N18

- Note 1. In order for the servo amplifier to comply with the UL/CSA standard, refer to the applicable "Servo amplifier instruction manual".
- Note 2. Use a magnetic contactor with an operation delay time (interval between current being applied to the coil until closure of contacts) of 80 ms or less.

Servo amplifier	Power supply specification	Circuit protector (Note)
MR-J3W-0303BN6	Control circuit power supply (24 V DC)	CP30-BA 1P 1-M 1A
	Main circuit power supply (48 V DC)	CP30-BA 1P 1-M 5A
	Control circuit power supply/main circuit power supply (24 V DC)	CP30-BA 1P 1-M 10A

Note. For operation characteristics, use an intermediate speed type.

Part 10: Review on Replacement of Optional Peripheral Equipment

4.3.4 MR-J4W2-_B servo amplifier, no-fuse breakers, fuses, magnetic contactors

Always use one molded-case circuit breaker and one magnetic contactor with one servo amplifier. When using a fuse instead of the molded-case circuit breaker, use the one having the specifications given in this section.

When using a combination of the rotary servo motor select a molded-case circuit breaker, a fuse or a magnetic contactor tentatively, assuming one type of the servo motors are used for two axes. After the tentative selections are made for all types of the servo motors, use the largest among all molded-case circuit breakers, fuses, or magnetic contactors.

(1) For main circuit power supply

CAUTION

- To prevent the servo amplifier from smoke and a fire, select a molded-case circuit breaker which shuts off with high speed.
- Always use one molded-case circuit breaker and one magnetic contactor with one servo amplifier.

(a) For MR-J4W2-_B

Total output of rotary servo motors	Molded-case circuit breaker (Note 5, 6)		Fuse			Magnetic Contactor (Note 2)
	Frame, rated current	Voltage AC [V]	Class (Note 1)	Current [A]	Voltage AC [V]	
300 W or less	50 A frame 5 A (Note 3)	240	T	15	300	S-N10 S-T10
From over 300 W to 600 W	50 A frame 10 A (Note 3)			20		
From over 600 W to 1 kW	50 A frame 15 A (Note 3)			20		
From over 1 kW to 2 kW	50 A frame 20 A (Note 3)			30		S-N20 (Note 4) S-T21

- Note
1. In order for the servo amplifier to comply with the UL/CSA standard, refer to the applicable "Servo amplifier instruction manual".
 2. Use a magnetic contactor with an operation delay time (interval between current being applied to the coil until closure of contacts) of 80 ms or less.
 3. When not using the servo amplifier as an EC/EN/UL/CSA standard compliant product, molded-case circuit breaker of 30 A frame can be used.
 4. S-N18 can be used when auxiliary contact is not required.
 5. A molded-case circuit breaker will not change to select regardless of use of a power factor improving AC reactor.
 6. Use a molded-case circuit breaker having the operation characteristics equal to or higher than Mitsubishi Electric general-purpose products.

(2) For control circuit power supply

When the wiring for the control circuit power supply (L11/L21) is thinner than that for the main circuit power supply (L1/L2/L3), install an overcurrent protection device (molded-case circuit breaker or fuse) to protect the branch circuit.

Servo amplifier	Molded-case circuit breaker		Fuse (Class T)		Fuse (Class K5)	
	Frame, rated current	Voltage AC [V]	Current [A]	Voltage AC [V]	Current [A]	Voltage AC [V]
MR-J4W2-22B	50 A frame 5 A (Note)	240	1	300	1	250
MR-J4W2-44B						
MR-J4W2-77B						
MR-J4W2-1010B						

Note. When not using the servo amplifier as an EC/EN/UL/CSA standard compliant product, molded-case circuit breaker of 30 A frame can be used.

Part 10: Review on Replacement of Optional Peripheral Equipment

(3) DC 24 V/DC 48 V class servo amplifier

Servo amplifier	Power supply specification	Circuit protector (Note)
MR-J4W2-0303BN6	Control circuit power supply (24 V DC)	CP30-BA 1P 1-M 1A
	Main circuit power supply (48 V DC)	CP30-BA 1P 1-M 5A
	Main circuit power supply (24 V DC)	CP30-BA 1P 1-M 10A

Note. For operation characteristics, use an intermediate speed type.

Part 10: Review on Replacement of Optional Peripheral Equipment

5. BATTERY

POINT	
	<ul style="list-style-type: none"> ● Refer to each servo amplifier instruction manual for the replacement procedure of the battery. ● Disconnecting the encoder cable will erase the absolute position data. After disconnecting the encoder cable, always execute home position setting and then positioning operation. ● The battery MR-J3BAT for MR-J3 series is unavailable because the voltage specification of the battery differs from that for MR-J4 series. ● The battery MR-BAT for MR-J3W series is unavailable because the voltage specification of the battery differs from that for MR-J4 series. ● The internal circuits of the servo amplifier may be damaged by static electricity. Always take the following precautions. <ul style="list-style-type: none"> ▪ Ground human body and work bench. ▪ Do not touch the conductive areas, such as connector pins and electrical parts, directly by hand.



WARNING

- Before replacing a battery, turn off the main circuit power and wait for 15 minutes or longer (when 30 kW or more is used, 20 minutes or more) until the charge lamp turns off. Then, check the voltage between P+ and N- with a voltage tester or others. Otherwise, an electric shock may occur. In addition, when confirming whether the charge lamp is off or not, always confirm it from the front of the servo amplifier.
- If [AL. 25 Absolute position erased] or [AL. E3 Absolute position counter warning] has occurred, always perform home position setting again. Otherwise, it may cause an unexpected operation.

5.1 Combinations of batteries and the servo amplifier

Model	Name	Built-in battery	MR-J3 series	MR-J4 series		MR-J3W series	MR-J4W2 servo amplifier
				MR-J4- _A_	MR-J4- _GF_		
MR-J3BAT	Battery		○			(Note 2)	
MR-BAT6V1SET	Battery	MR-BAT6V1		○			
MR-BAT6V1SET-A	Battery				○		(Note 3)
MR-BAT6V1BJ	Battery Battery for junction battery cable			○	○ (Note 5)		
MR-BT6VCASE	Battery case	MR-BAT6V1 (Note 1)		○	○		○ (Note 4)
MR-BTCASE	Battery case	MR-BAT (Note 1)				○	

- Note
1. Please purchase the battery separately.
 2. It is available with MR-J3W-0303BN6.
 3. It is available with MR-J4W2-0303B6.
 4. MR-BT6VCASE cannot be used for MR-J4W2-0303B6 servo amplifiers.
 5. For support with MR-J4-350GF4 (-RJ), contact your local sales office.

Part 10: Review on Replacement of Optional Peripheral Equipment

5.2 MR-J3 series Battery

(1) Purpose of use for MR-J3BAT

This battery is used to construct an absolute position detection system. Refer to each servo amplifier instruction manual for the fitting method, etc..

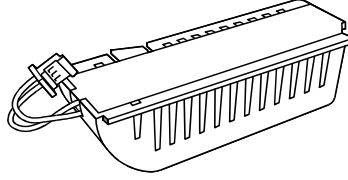

(2) Year and month when MR-J3BAT is manufactured

Production year and month of the MR-J3BAT are indicated in a serial number on the rating plate of the battery back face.

The year and month of manufacture are indicated by the last one digit of the year and 1 to 9, X (10), Y (11), Z (12).

For October 2004, the Serial No. is like, "SERIAL_4X_ _ _ _ _".

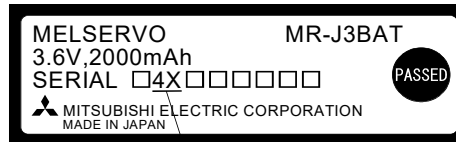

The year and month of manufacture

Part 10: Review on Replacement of Optional Peripheral Equipment

5.3 MR-J4 series Battery

5.3.1 Battery replacement procedure

Model: MR-BAT6V1SET, MR-BAT6V1SET-A, MR-BAT6V1BJ, MR-BT6VCASE

WARNING

- Before replacing a battery, turn off the main circuit power and wait for 15 minutes or longer until the charge lamp turns off. Then, check the voltage between P+ and N- with a voltage tester or others. Otherwise, an electric shock may occur. In addition, when confirming whether the charge lamp is off or not, always confirm it from the front of the servo amplifier.

CAUTION

- The internal circuits of the servo amplifier may be damaged by static electricity. Always take the following precautions.
 - Ground your body and the work bench.
 - Do not touch the conductive areas, such as connector pins and electrical parts, directly by hand.
- The built-in battery for the MR-BAT6V1BJ battery for junction battery cable cannot be replaced. Therefore, do not disassemble the MR-BAT6V1BJ battery for junction battery cable. Doing so may cause a malfunction.

POINT

- When using the BAT6V1SET battery, the MR-BAT6V1SET-A and the MR-BT6VCASE battery case are used
Replacing a battery with the control circuit power supply turned off will erase the absolute position data.
When using the MR-BAT6V1BJ battery for junction battery cable
In order to prevent the absolute position data from being erased, replace the MR-BAT6V1BJ battery for junction battery cable according to the procedure described in each instruction manual.
- Verify that the battery for replacement is within its service life.
- Refer to each instruction manual for battery transportation and the new EU Battery Directive.

Replace the old battery with only the control circuit power supply turned on. Replacing a battery with the control circuit power supply turned on will cause [AL.9F.1 low battery] but will not erase the absolute position data.

Refer to each servo amplifier instruction manual for the procedure for mounting the battery on the servo amplifier.

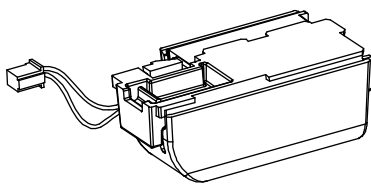

MR-BAT6V1SET

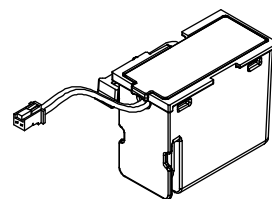

MR-BAT6V1SET-A

Part 10: Review on Replacement of Optional Peripheral Equipment

POINT
<ul style="list-style-type: none"> ● Four types of batteries are used to construct the absolute position detection system: MR-BAT6V1SET battery, MR-BAT6V1SET-A battery, MR-BAT6V1BJ battery for junction battery cable, and MR-BT6VCASE battery case. The use of the MR-BAT6V1BJ battery for junction battery cable has the following characteristics distinctive from other batteries. <ul style="list-style-type: none"> ▪ The encoder cable can be removed from the servo amplifier. ▪ A battery can be replaced with the control circuit power supply turned off. ● If the encoder lost the absolute position data, always perform home position setting before operation. The encoder will lose the absolute position data in the following cases. In addition, the absolute position data may be erased if the battery is used outside of the specification. <p>When using the MR-BAT6V1SET battery, the MR-BAT6V1SET-A battery and the MR-BT6VCASE battery case</p> <ul style="list-style-type: none"> ▪ Encoder cable is removed. ▪ A battery is replaced with the control circuit power supply turned off. <p>When using the MR-BAT6V1BJ battery for junction battery cable</p> <ul style="list-style-type: none"> ▪ The connector and the cable are removed between the servo motor and the battery. ▪ A battery is replaced in a procedure different from the procedure described in each instruction manual. ● A single MR-BT6VCASE battery case can retain the absolute position data of up to eight axes of servo motors.

5.3.2 When using the MR-BAT6V1SET battery and the MR-BAT6V1SET-A battery

(a) Battery connection

Connect according to the following figure.

The figure shows the case where the MR-BAT6V1SET battery is used.

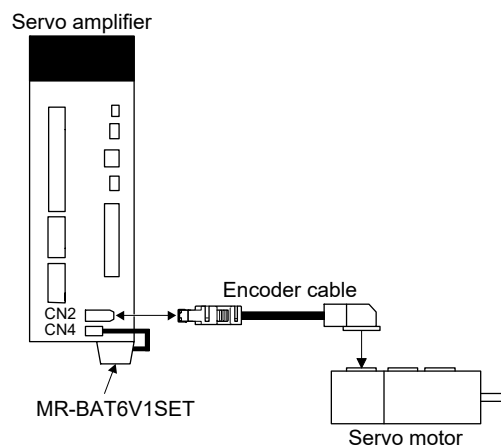

(b) Year and month of manufacture of battery

The manufacture date of an MR-BAT6V1 battery installed in MR-BAT6V1SET and MR-BAT6V1SET-A is written on the name plate attached to the MR-BAT6V1 battery.

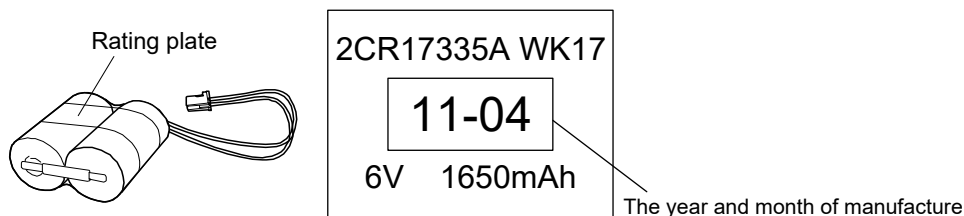

Part 10: Review on Replacement of Optional Peripheral Equipment

5.3.3 When using MR-BAT6V1BJ battery for junction battery cable

(a) Battery mounting

Connect the MR-BAT6V1BJ using the MR-BT6VCBL03M junction battery cable as follows.

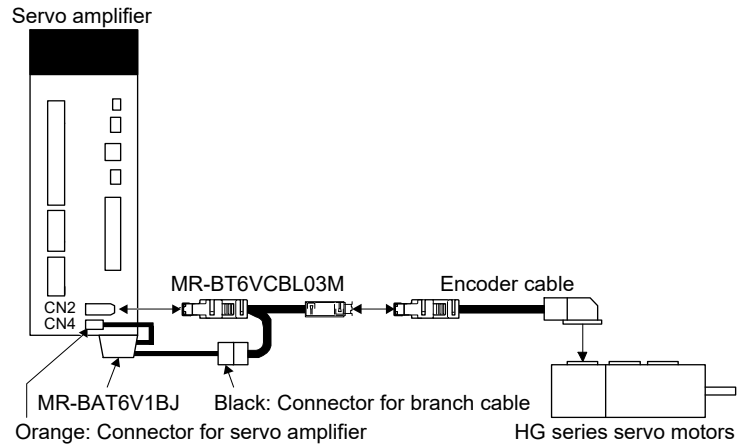

(b) Battery manufacture year and month

The manufacture year and month are described in the manufacturer's (SERIAL) number marked on the rating name plate. The second digit of the manufacturer's number indicates the first digit of the Christian Era and the third digit indicates the manufacture month (X for October, Y for November, and Z for December). For example, November 2013 is indicated as "SERIAL: _3Y_____".

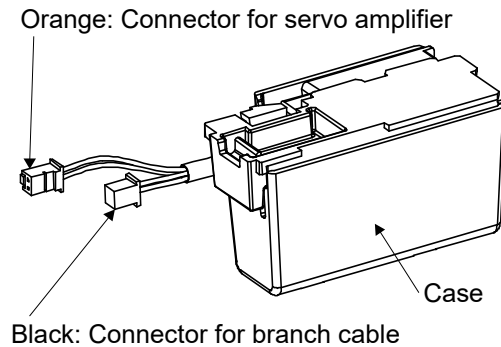

Part 10: Review on Replacement of Optional Peripheral Equipment

5.3.4 When using MR-BT6VCASE battery case

(a) Battery connection

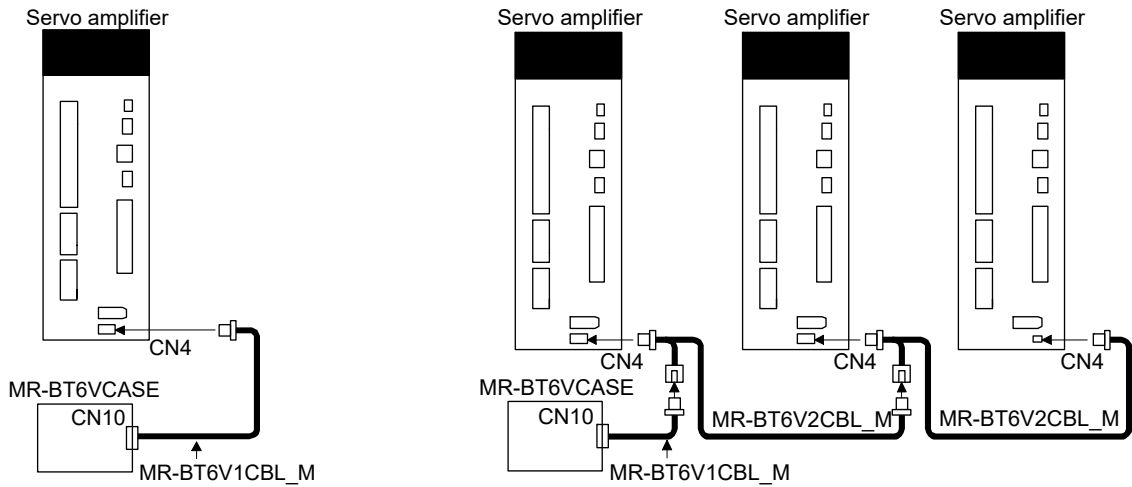

Connection to a single unit of servo amplifier

Connection to eight axes of servo amplifiers

A single MR-BT6VCASE battery case can retain the absolute position data of up to eight axes of servo motors. Servo motors in the incremental system are included in the number of axes. Refer to the following table for the number of connectable axes of each servo motor.

Servo motor	Number of axes									
Rotary servo motor	0	1	2	3	4	5	6	7	8	

The battery case accommodates five connected batteries. The battery case contains no batteries. Batteries need to be prepared separately.

(b) Battery manufacture year and month

The manufacture year and month of a MR-BAT6V1 to be housed in the MR-BT6VCASE battery case is written on the name plate attached to the MR-BAT6V1 battery.

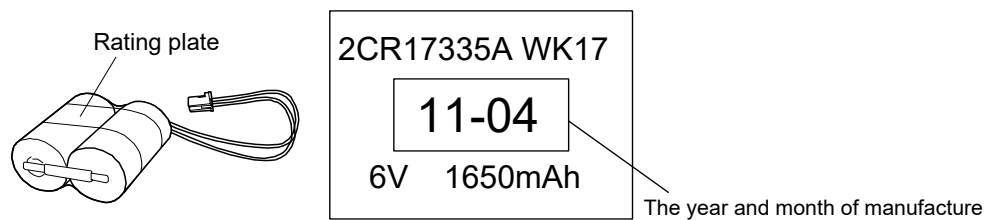

Part 10: Review on Replacement of Optional Peripheral Equipment

5.4 MR-J3W series Battery

5.4.1 MR-BTCASE battery case and MR-BAT battery

POINT
<ul style="list-style-type: none"> ● Refer to "Servo amplifier instruction manual" for battery transportation and the new EU Battery Directive. ● Always install eight MR-BAT batteries to an MR-BTCASE battery case.

These are used to configure an absolute position detection system. An MR-BTCASE battery case is a case that stores eight MR-BAT batteries by connector connections. An MR-BTCASE battery case can be used by four MR-J3W-B servo amplifiers (eight axes) at maximum. To connect an MR-BTCASE battery case to a servo amplifier, the MR-J3BT1CBL_M battery cable is required. To connect multiple servo amplifiers to an MR-BTCASE battery case, use the MR-J3BT2CBL_M junction battery cable. When using an MR-J3W-B servo amplifier in the incremental system, MR-BTCASE and MR-BAT are not required.

Battery backup time (battery life without charging) is 30,000 hours for one servo amplifier (two axes) and 10,000 hours for four servo amplifiers (eight axes). Refer to servo amplifier instruction manual for the usage.

[Unit: mm]

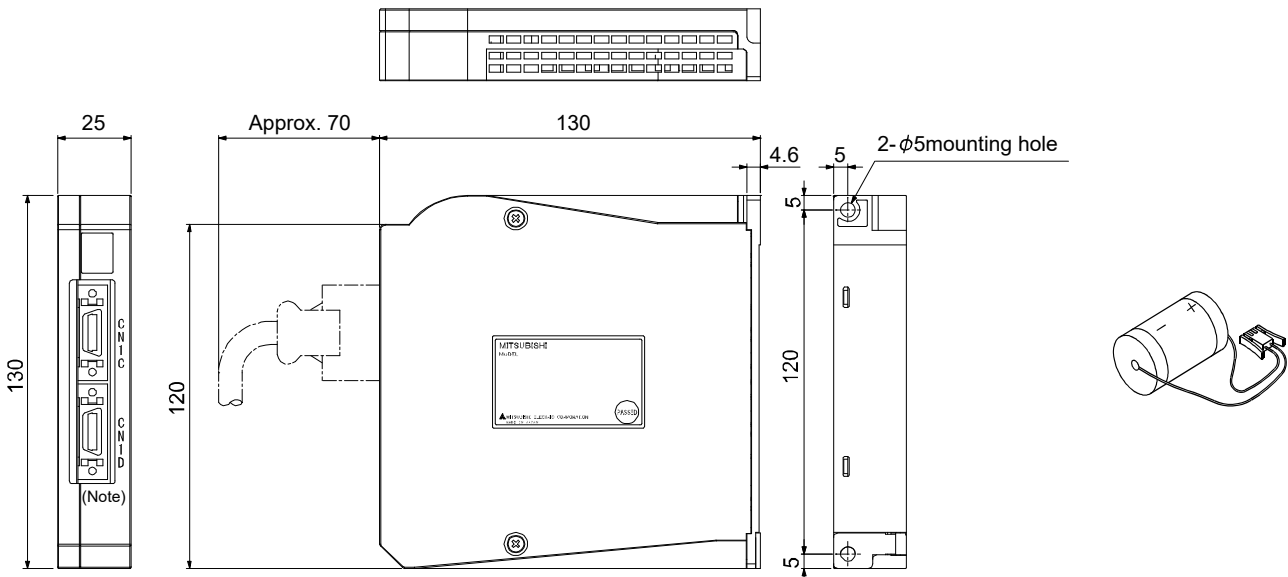

Note. Leave this open.

Mass: 0.3 [kg]

Outline dimension drawing of MR-BTCASE

Appearance of MR-BAT

The next table shows model names of battery cables. The numbers in the Cable length column in the table go into "_" of the cable model names.

Cable model	Cable length		Fix life	Application / Remark
	0.3 m	1 m		
MR-J3BT1CBL_M	03	1	Standard	
MR-J3BT2CBL_M	03	1	Standard	For junction

Part 10: Review on Replacement of Optional Peripheral Equipment

5.5 MR-J4W2-_B servo amplifier, battery

POINT
<ul style="list-style-type: none"> ● Refer to "Servo amplifier instruction manual" for battery transportation and the new EU Battery Directive.

This battery is used to construct an absolute position detection system. Refer to "Servo amplifier instruction manual" for construction of the absolute position detection system.

5.5.1 MR-BT6VCASE battery case

POINT
<ul style="list-style-type: none"> ● Use an MR-BT6VCASE for 200 W or more MR-J4W _ _ B servo amplifiers. MR-BT6VCASE cannot be used for MR-J4W2-0303B6 servo amplifiers. ● The battery unit consists of an MR-BT6VCASE battery case and five MR-BAT6V1 batteries. ● For the specifications and year and month of manufacture of MR-BAT6V1 battery, refer to "Servo amplifier instruction manual".

MR-BT6VCASE is a case used for connecting and mounting five MR-BAT6V1 batteries. A battery case does not have any batteries. Please prepare MR-BAT6V1 batteries separately.

(1) The number of connected servo motors

One MR-BT6VCASE holds absolute position data up to eight axes servo motors.

Servo motors in the incremental system are included as the axis Nos. Refer to the following table. for the number of connectable axes of each servo motor.

(2) Dimensions

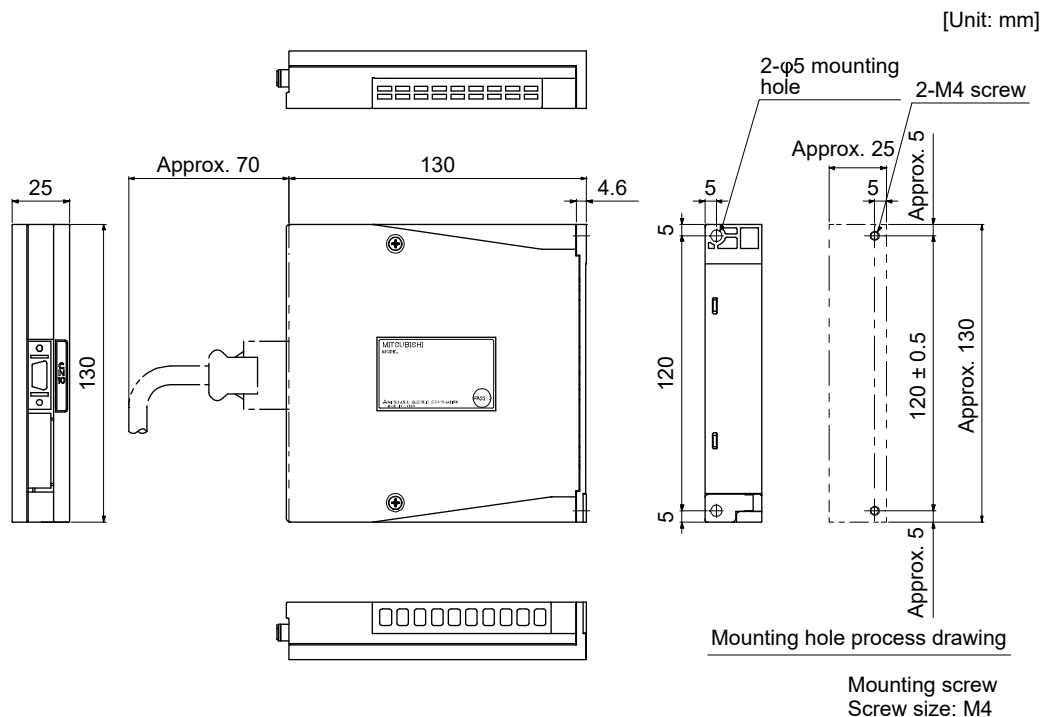

[Mass: 0.18 kg]

Part 10: Review on Replacement of Optional Peripheral Equipment

(3) Battery mounting

POINT
<ul style="list-style-type: none"> ● One battery unit can be connected to up to 8-axis servo motors. Servo motors in the incremental system are included as the axis Nos. ● The MR-J4W_-_B servo amplifiers can be combined with MR-J4-_B_(-RJ) servo amplifiers.

(a) When using 1-axis servo amplifier

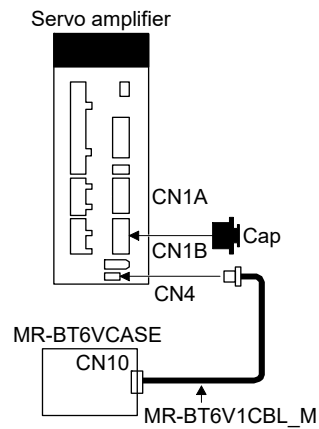

(b) When using up to 8-axis servo amplifiers

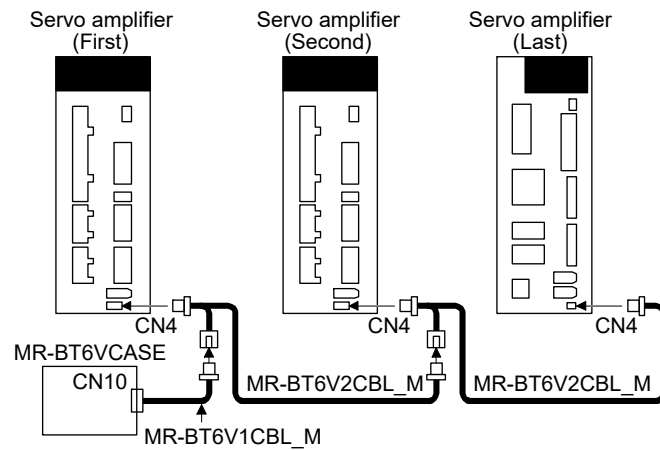

Part 10: Review on Replacement of Optional Peripheral Equipment

(4) Battery replacement procedure



WARNING

- Before replacing a battery, turn off the main circuit power and wait for 15 minutes or longer until the charge lamp turns off. Then, check the voltage between P+ and N- with a voltage tester or others. Otherwise, an electric shock may occur. In addition, when confirming whether the charge lamp is off or not, always confirm it from the front of the servo amplifier.



CAUTION

- The internal circuits of the servo amplifier may be damaged by static electricity. Always take the following precautions.
 - Ground human body and work bench.
 - Do not touch the conductive areas, such as connector pins and electrical parts, directly by hand.

POINT

- Replacing battery with the control circuit power off will erase the absolute position data.
- Before replacing batteries, check that the new battery is within battery life.

Replace the battery while only control circuit power is on. Replacing battery with the control circuit power on triggers [AL. 9F.1 Low battery]. However, the absolute position data will not be erased.

Part 10: Review on Replacement of Optional Peripheral Equipment

(a) Assembling a battery unit

CAUTION	<ul style="list-style-type: none"> ● Do not mount new and old batteries together. ● When you replace a battery, replace all batteries at the same time.
----------------	---

POINT	<ul style="list-style-type: none"> ● Always install five MR-BAT6V1 batteries to an MR-BT6VCASE battery case.
--------------	---

1) Required items

Product name	Model	Quantity	Remark
Battery case	MR-BT6VCASE	1	MR-BT6VCASE is a case used for connecting and mounting five MR-BAT6V1 batteries.
Battery	MR-BAT6V1	5	Lithium battery (primary battery, nominal + 6 V)

2) Disassembly and assembly of the battery case MR-BT6VCASE

a) Disassembly of the case

MR-BT6VCASE is shipped assembled. To mount MR-BAT6V1 batteries, the case needs to be disassembled.

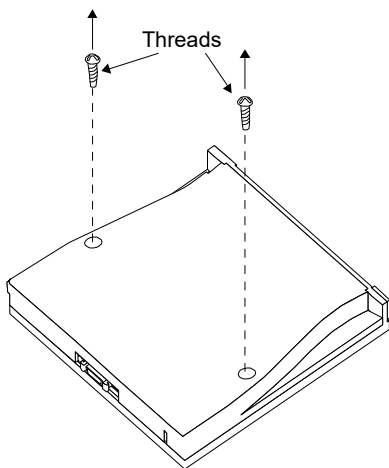

Remove the two screws using a Phillips screwdriver.

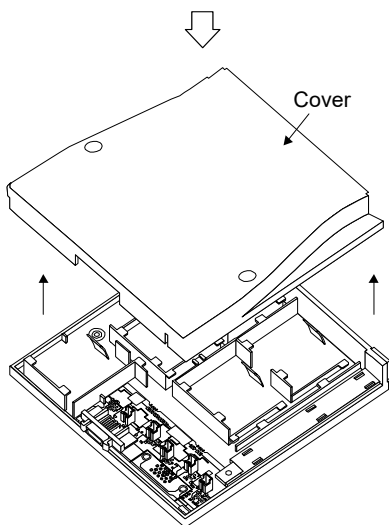

Remove the cover.

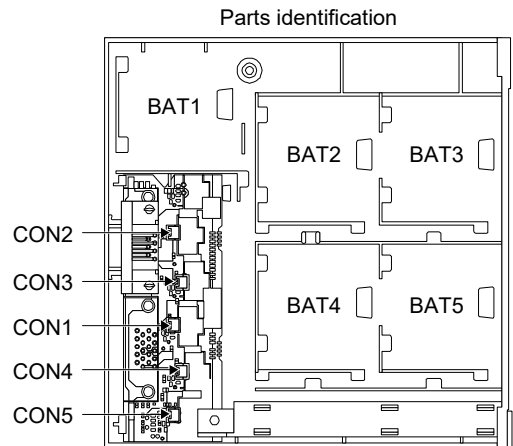

Part 10: Review on Replacement of Optional Peripheral Equipment

b) Mounting MR-BAT6V1

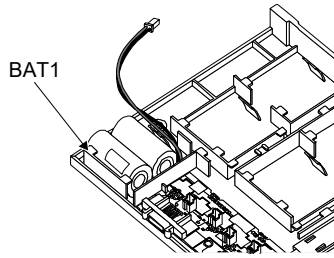

Securely mount an MR-BAT6V1 to the BAT1 holder.

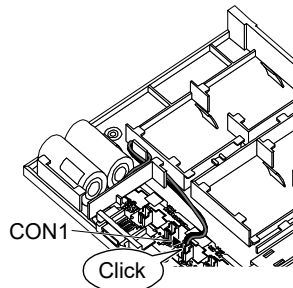

Insert the MR-BAT6V1 connector mounted on BAT1 holder to CON1.

Confirm the click sound at this point.

The connector has to be connected in the right direction.

If the connector is pushed forcefully in the incorrect direction, the connector will break.

Place the MR-BAT6V1 lead wire to the duct designed to store lead wires.

Insert MR-BAT6V1 to the holder in the same procedure in the order from BAT2 to BAT5.

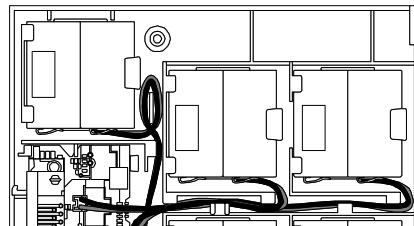

Bring out the lead wire from the space between the ribs, and bend it as shown above to store it in the duct. Connect the lead wire to the connector. Be careful not to get the lead wire caught in the case or other parts.

When the lead wire is damaged, external short circuit may occur, and the battery can become hot.

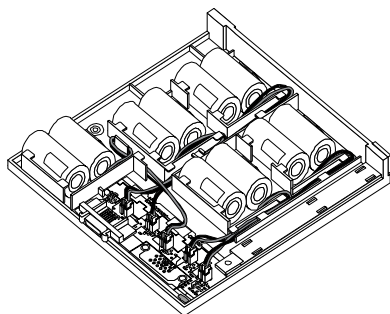

Part 10: Review on Replacement of Optional Peripheral Equipment

c) Assembly of the case

After all MR-BAT6V1 batteries are mounted, fit the cover and insert screws into the two holes and tighten them. Tightening torque is 0.71 N·m.

POINT

- When assembling the case, be careful not to get the lead wires caught in the fitting parts or the screwing parts.

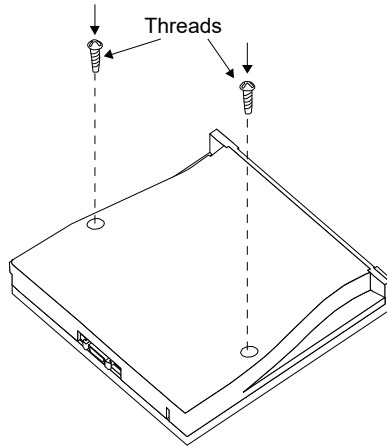

d) Precautions for removal of battery

The connector attached to the MR-BAT6V1 battery has the lock release lever. When removing the connector, pull out the connector while pressing the lock release lever.

3) Battery cable removal

CAUTION

- Pulling out the connector of the MR-BT6V1CBL and the MR-BT6V2CBL without the lock release lever pressed may damage the CN4 connector of the servo amplifier or the connector of the MR-BT6V1CBL or MR-BT6V2CBL.

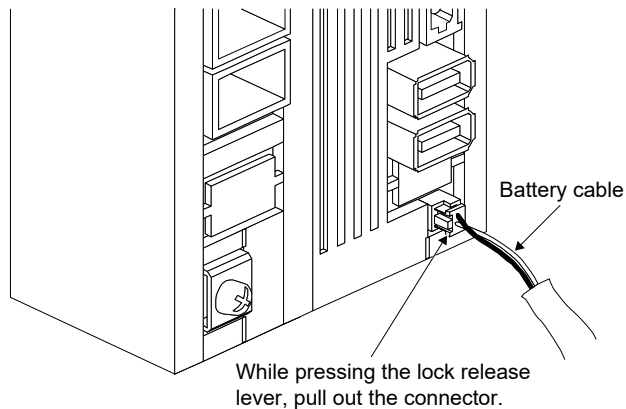

Part 10: Review on Replacement of Optional Peripheral Equipment

5.5.2 MR-BAT6V1 battery

The MR-BAT6V1 battery is a primary lithium battery for replacing MR-BAT6V1SET-A and MR-BAT6V1SET and a primary lithium battery built-in MR-BT6VCASE. Store the MR-BAT6V1 in the case to use.

The year and month of manufacture of MR-BAT6V1 battery have been described to the rating plate put on an MR-BAT6V1 battery.

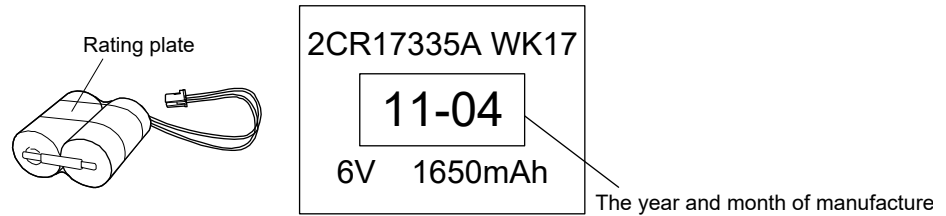

Item	Description
Battery pack	2CR17335A (CR17335A × 2 pcs. in series)
Nominal voltage [V]	6
Nominal capacity [mAh]	1650
Storage temperature [°C]	0 to 55
Operating temperature [°C]	0 to 55
Lithium content [g]	1.2
Mercury content	Less than 1 ppm
Dangerous goods class	Not subject to the dangerous goods (Class 9) Refer to app. 2 for details.
Operating humidity and storage humidity	5 %RH to 90 %RH (non-condensing)
Battery life (Note)	5 years from date of manufacture
Mass [g]	34

Note. Quality of the batteries degrades by the storage condition. The battery life is 5 years from the production date regardless of the connection status.

Part 10: Review on Replacement of Optional Peripheral Equipment

5.5.3 MR-BAT6V1SET-A battery (MR-J4W2-0303B6 only)

POINT
● Use MR-BAT6V1SET-A for MR-J4W2-0303B6 servo amplifier. The MR-BAT6V1SET-A cannot be used for MR-J4W_-B servo amplifiers other than MR-J4W2-0303B6.

(1) Parts identification and dimensions

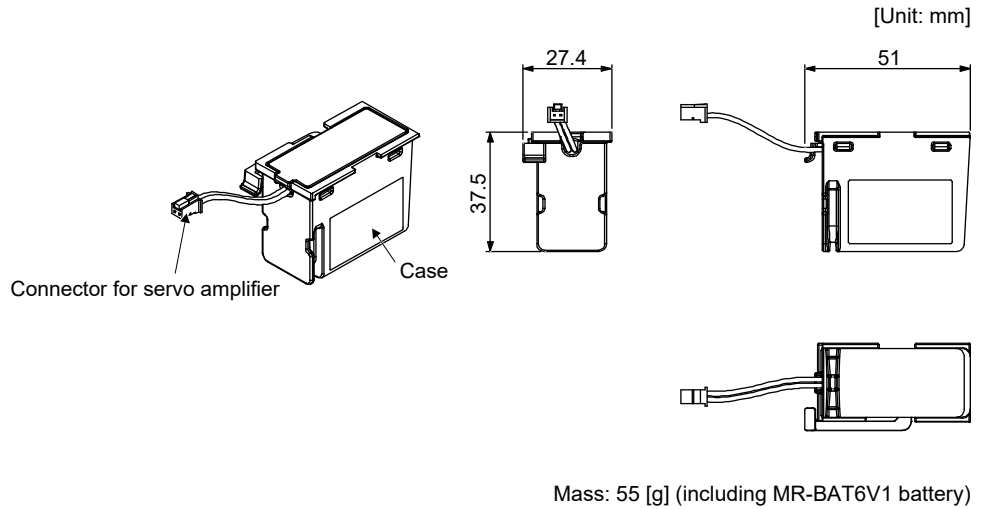

(2) Battery mounting Connect as follows.

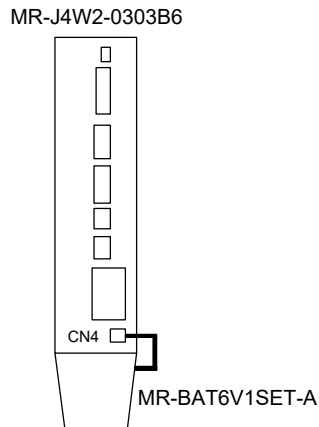

Part 10: Review on Replacement of Optional Peripheral Equipment

(3) Battery replacement procedure

(a) Installation procedure

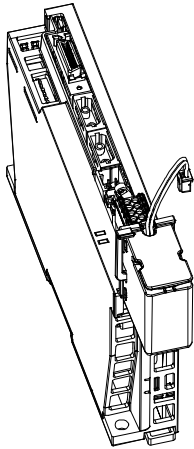

Insert the battery along the rails.

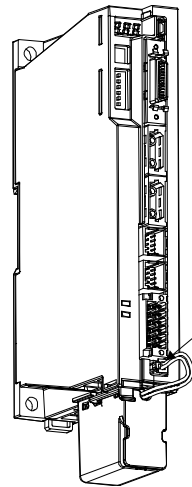

Insert the connector of the battery into CN4.

(b) Removal procedure



● Pulling out the connector of the battery without the lock release lever pressed may damage the CN4 connector of the servo amplifier or the connector of the battery.

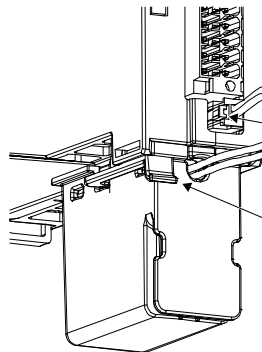

While pressing the lock release lever, pull out the connector.

While pressing the lock release lever, slide the battery case toward you.

Part 10: Review on Replacement of Optional Peripheral Equipment

(4) Replacement procedure of the built-in battery

When the MR-BAT6V1SET-A reaches the end of its life, replace the built-in MR-BAT6V1 battery.

1) While pressing the locking part, open the cover.

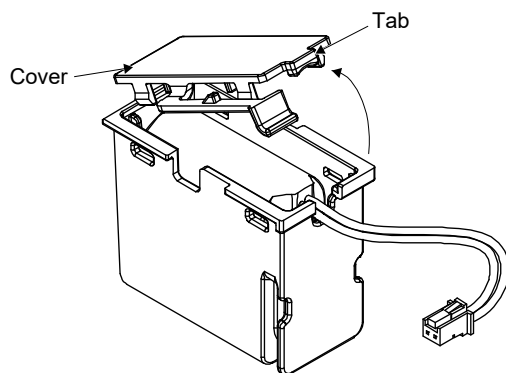

2) Replace the battery with a new MR-BAT6V1 battery.

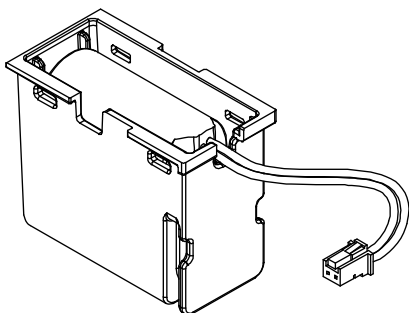

3) Press the cover until it is fixed with the projection of the locking part to close the cover.

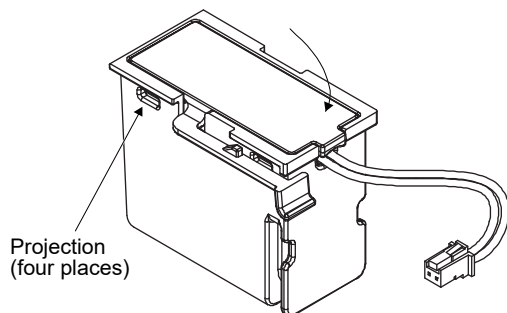

Part 10: Review on Replacement of Optional Peripheral Equipment

6. EMC FILTER (RECOMMENDED)

6.1 MR-J3/MR-J3W/MR-J4 series EMC Filter (recommended) (100 V/200 V/400 V class)

It is recommended that one of the following filters be used to comply with EN EMC directive. Some EMC filters have large in leakage current.

When using an EMC filter, always use one for each servo amplifier.

Combination with the servo amplifier

Servo amplifier	Recommended filter (Soshin Electric)				Mass [kg]			
	Model	Rated current [A]	Rated voltage [V AC]	Leakage current [mA]				
MR-J3-10_ to MR-J3-100_ MR-J3-10_1 to MR-J3-40_1 MR-J4-10_(-RJ) to MR-J4-100_(-RJ) MR-J4-10_1(-RJ) to MR-J4-40_1(-RJ) MR-J3W-22B/MR-J3W-44B MR-J4W2-22B	HF3010A-UN (Note)	10	Max. 250	5	3.5			
MR-J4W2-44B	HF3010A-UN2 (Note)							
MR-J3-200_N/MR-J3-350_ MR-J4-200_(-RJ) MR-J4-350_(-RJ) MR-J3W-77B MR-J3W-1010B MR-J4W2-77B MR-J4W2-1010B	HF3030A-UN (Note)	30				5.5		
MR-J3-500_ MR-J3-700_ MR-J4-500_(-RJ) MR-J4-700_(-RJ)	HF3040A-UN (Note)	40						
MR-J3-11K_ to MR-J3-22K_ MR-J4-11K_(-RJ) to MR-J4-22K_(-RJ)	HF3100A-UN (Note)	100					6.5	6
MR-J3-DU30K_ MR-J3-DU37K_ MR-J4-DU30K_ MR-J4-DU37K_	HF3200A-UN (Note)	200					9	12
MR-J3-60_4 MR-J3-100_4 MR-J4-60_4(-RJ) MR-J4-100_4(-RJ)	TF3005C-TX	5		Max. 500	5.5		6	
MR-J3-200_4 to MR-J3-700_4 MR-J4-200_4(-RJ) to MR-J4-700_4(-RJ)	TF3020C-TX	20						
MR-J3-11K_4 MR-J4-11K_4(-RJ)	TF3030C-TX	30						
MR-J3-15K_4 MR-J4-15K_4(-RJ)	TF3040C-TX	40						
MR-J3-22K_4 MR-J4-22K_4(-RJ)	TF3060C-TX	60				7.5		
MR-J3-DU30K_4 to MR-J3-DU55K_4 MR-J4-DU30K_4 to MR-J4-DU55K_4	TF3150C-TX	150				12.5		
			31					

Note. This surge protector is separately required to use any of these EMC filters.

Part 10: Review on Replacement of Optional Peripheral Equipment

6.1.1 Connection example

(1) MR-J3/MR-J3W series

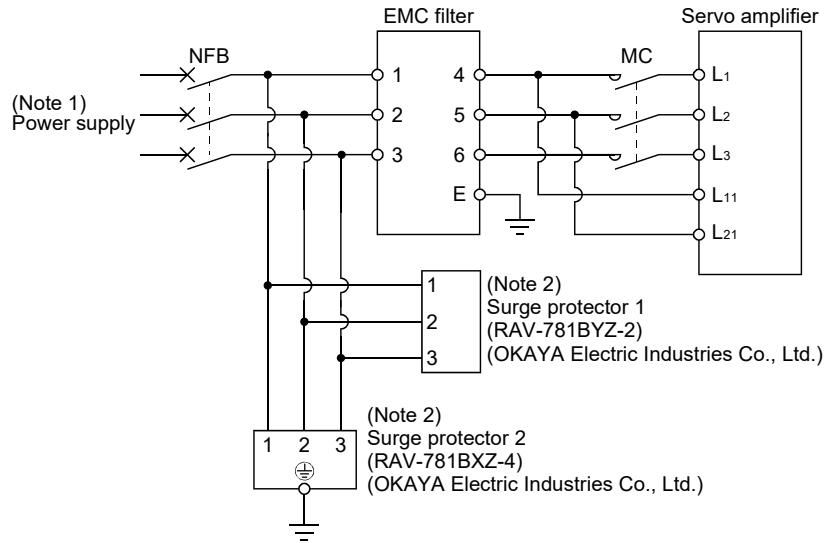

- Note 1. For 1-phase 200 to 230V AC power supply, connect the power supply to L1, L2 and leave L3 open.
There is no L3 for 1-phase 100 to 120 V AC power supply.
2. The example is when a surge protector is connected.

(2) MR-J4 series 200 V/100 V class

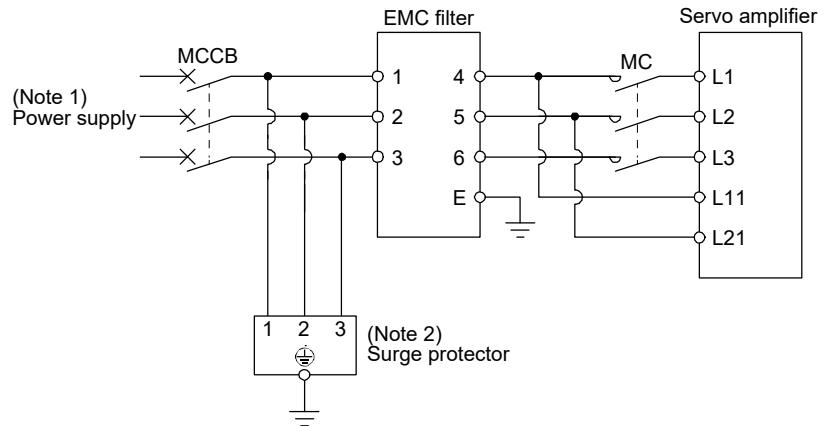

- Note 1. For 1-phase 200 to 240V AC power supply, connect the power supply to L1, L3 and leave L2 open.
There is no L2 for 1-phase 100 to 120 V AC power supply.
2. The example is when a surge protector is connected.

(3) MR-J4 series 400 V class

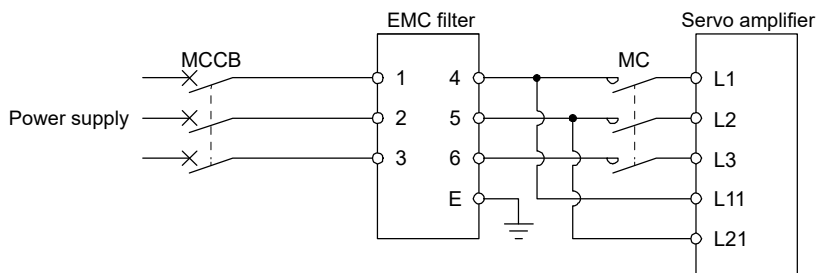

Part 10: Review on Replacement of Optional Peripheral Equipment

6.1.2 Dimensions

(1) EMC filter
 HF3010A-UN/HF3010A-UN2

[Unit: mm]

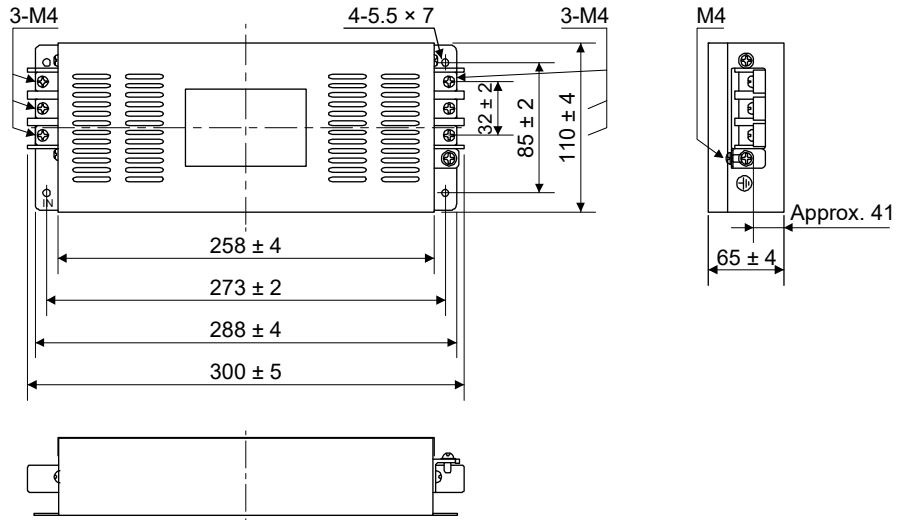

HF3030A-UN/HF3040A-UN

[Unit: mm]

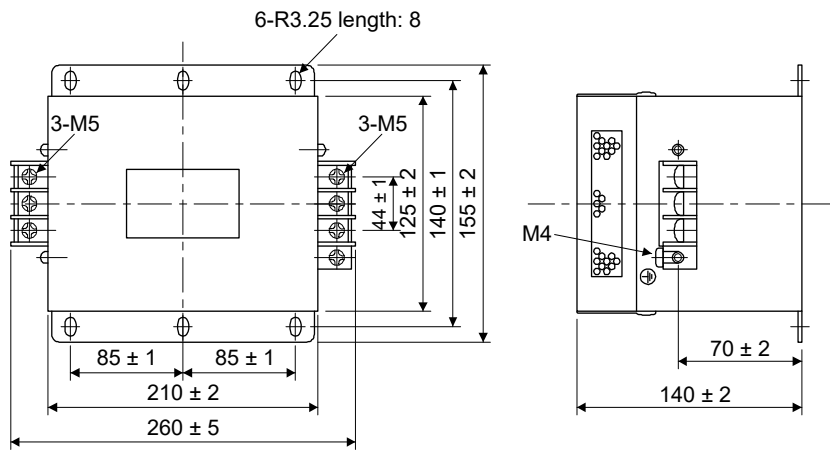

Part 10: Review on Replacement of Optional Peripheral Equipment

HF3100A-UN

[Unit: mm]

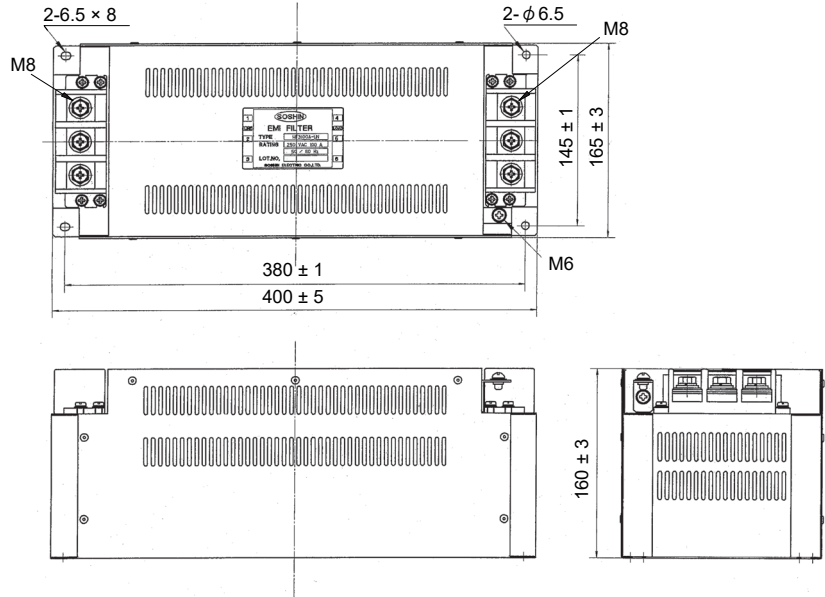

TF3005C-TX/TF3020C-TX/TF3030C-TX

[Unit: mm]

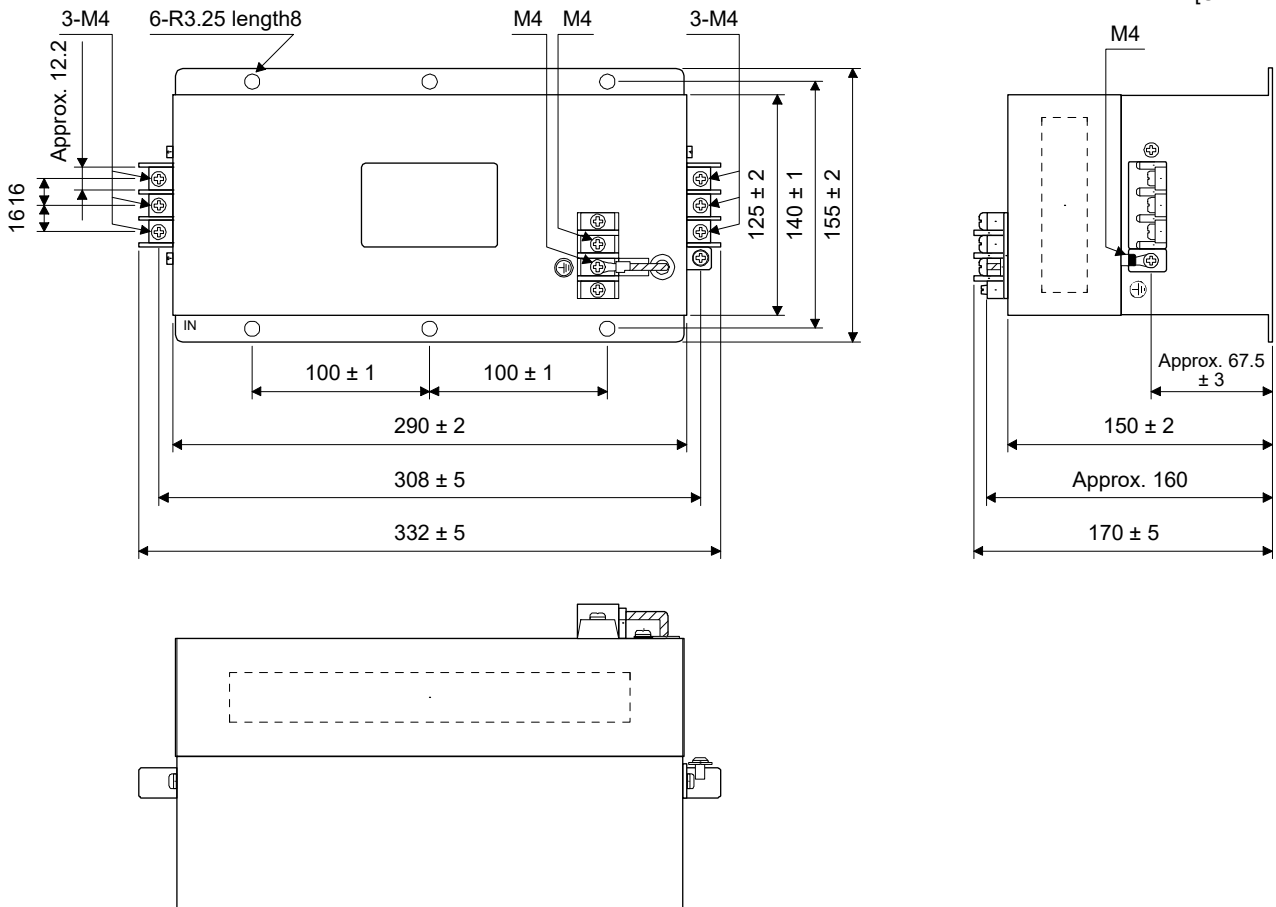

Part 10: Review on Replacement of Optional Peripheral Equipment

TF3040C-TX/TF3060C-TX

[Unit: mm]

8-R3.25 Length 8 (for M6)

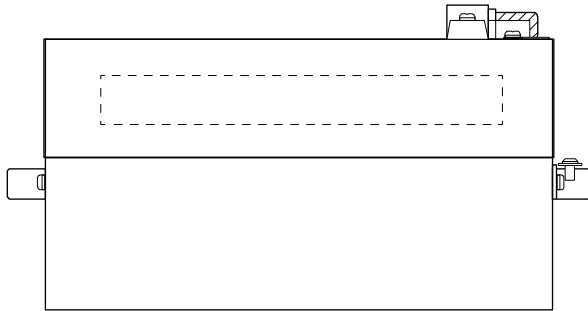
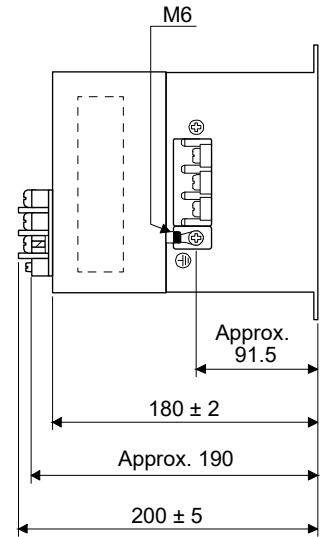
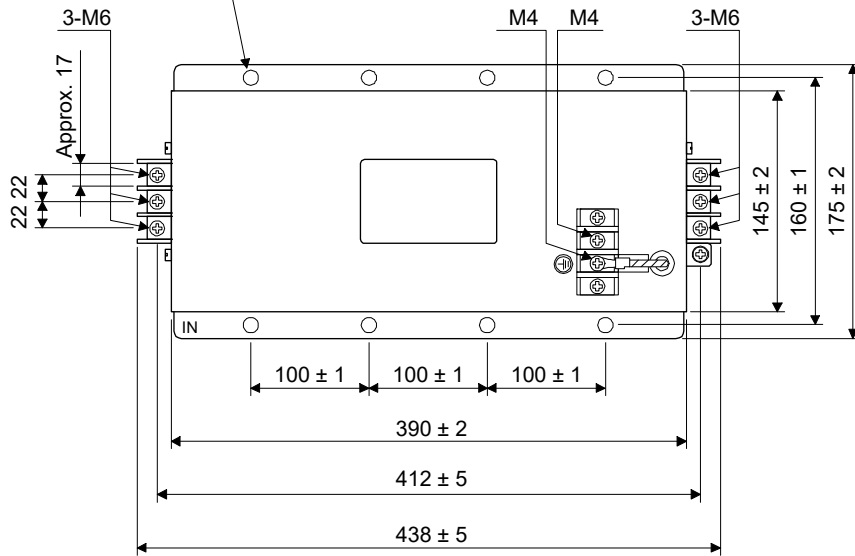

Part 10: Review on Replacement of Optional Peripheral Equipment

(2) Surge protector

<p style="text-align: center;">RAV-781BYZ-2</p>	<p style="text-align: center;">[Unit: mm]</p>
<p style="text-align: center;">RAV-781BXZ-4</p>	<p style="text-align: center;">[Unit: mm]</p>
<p style="text-align: center;">RSPD-250-U4</p>	<p style="text-align: center;">[Unit: mm]</p>

Part 10: Review on Replacement of Optional Peripheral Equipment

7. POWER FACTOR IMPROVING DC REACTOR/POWER FACTOR IMPROVING AC REACTOR

7.1 MR-J3 series Power Factor Improving DC Reactor

POINT
● For the 100V AC power supply type (MR-J3-_A1) and MR-J3W series, the power factor improving DC reactor cannot be used.

The power factor improving DC reactor increases the form factor of the servo amplifier's input current to improve the power factor. It can decrease the power supply capacity. As compared to the power factor improving AC reactor (FR-BAL-(H)), it can decrease the loss. The input power factor is improved to about 95%. It is also effective to reduce the input side harmonics.

When connecting the power factor improving DC reactor to the servo amplifier, always disconnect P₁ and P₂ (For 11k to 22kW, disconnect P₁ and P). If it remains connected, the effect of the power factor improving DC reactor is not produced.

When used, the power factor improving DC reactor generates heat. To release heat, therefore, leave a 10 cm or more clearance at each of the top and bottom, and a 5 cm or more clearance on each side.

Part 10: Review on Replacement of Optional Peripheral Equipment

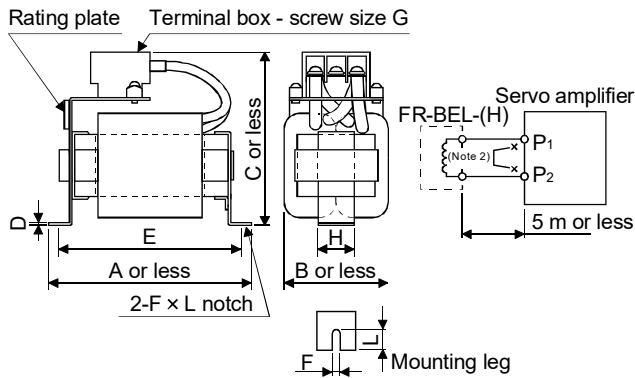

Fig. 10.1

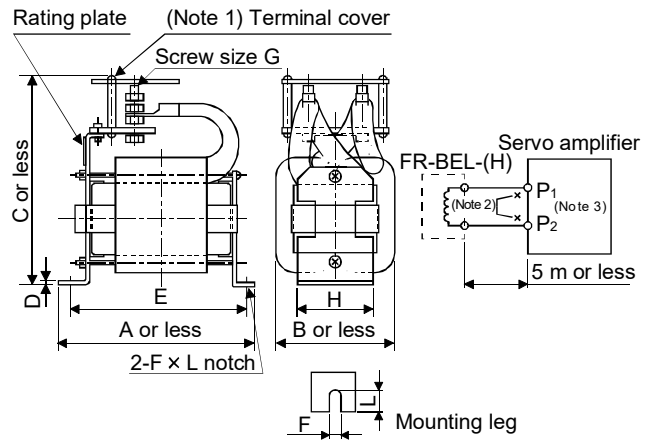

Fig. 10.2

- Note 1. Since the terminal cover is supplied, attach it after connecting a wire.
 Note 2. When using power factor improving DC reactor, disconnect P1 and P2.
 Note 3. When 11k to 22kW, "P2" becomes "P", respectively.

Servo amplifier	Power factor improving DC reactor	Outline drawing	Dimensions [mm]									Mounting screw size	Mass [kg (lb)]	Wire [mm ²] (Note)	
			A	B	C	D	E	F	L	G	H				
MR-J3-10_	FR-BEL-0.4K	Fug. 10.1	110	50	94	1.6	95	6	12	M3.5	25	M5	0.5	2 (AWG14)	
MR-J3-20_			120	53	102	1.6	105	6	12	M4	25	M5	0.7		
MR-J3-40_	FR-BEL-0.75K		130	65	110	1.6	115	6	12	M4	30	M5	1.1		
MR-J3-60_			130	65	110	1.6	115	6	12	M4	30	M5	1.2		
MR-J3-100_	FR-BEL-2.2K		150	75	102	2.0	135	6	12	M4	40	M5	1.7		
MR-J3-200_	FR-BEL-3.7K		150	75	126	2.0	135	6	12	M5	40	M5	2.3		3.5 (AWG12)
MR-J3-350_	FR-BEL-7.5K		170	93	132	2.3	155	6	14	M5	50	M5	3.1		5.5 (AWG10)
MR-J3-500_	FR-BEL-11K	Fug. 10.2	170	93	170	2.3	155	6	14	M8	56	M5	3.8	8 (AWG8)	
MR-J3-700_	FR-BEL-15K		185	119	182	2.6	165	7	15	M8	70	M6	5.4	22 (AWG4)	
MR-J3-11K_			185	119	201	2.6	165	7	15	M8	70	M6	6.7	30 (AWG2)	
MR-J3-22K_	FR-BEL-30K		185	119	201	2.6	165	7	15	M8	70	M6	6.7	60 (AWG2/0)	
MR-J3-60_4	FR-BEL-H1.5K	Fug. 10.1	130	63	89	1.6	115	6	12	M3.5	32	M5	0.9	2 (AWG14)	
MR-J3-100_4	FR-BEL-H2.2K		130	63	101	1.6	115	6	12	M3.5	32	M5	1.1		
MR-J3-200_4	FR-BEL-H3.7K		150	75	102	2	135	6	12	M4	40	M5	1.7		
MR-J3-350_4	FR-BEL-H7.5K		150	75	124	2	135	6	12	M4	40	M5	2.3		
MR-J3-500_4	FR-BEL-H11K		170	93	132	2.3	155	6	14	M5	50	M5	3.1		5.5 (AWG10)
MR-J3-700_4	FR-BEL-H15K	Fug. 10.2	170	93	160	2.3	155	6	14	M6	56	M5	3.7	8 (AWG8)	
MR-J3-11K_4			185	119	171	2.6	165	7	15	M6	70	M6	5.0	22 (AWG4)	
MR-J3-15K_4			FR-BEL-H22K	185	119	189	2.6	165	7	15	M6	70	M6		6.7
MR-J3-22K_4	FR-BEL-H30K		185	119	189	2.6	165	7	15	M6	70	M6	6.7		

Note. Selection condition of wire size is as follows.

Wire type: 600 V Polyvinyl chloride insulated wire (IV wire)

Construction condition: One wire is constructed in the air

Part 10: Review on Replacement of Optional Peripheral Equipment

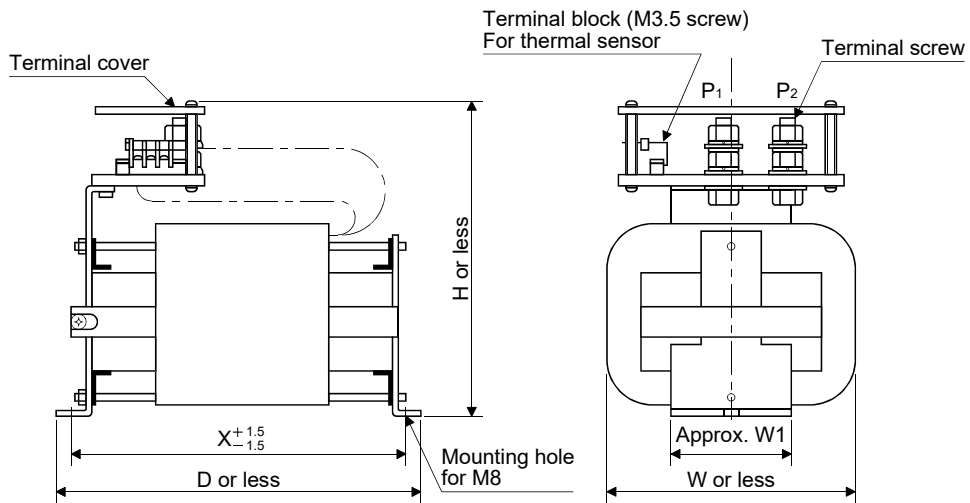

Drive unit	Power factor improving DC reactor	Dimensions [mm]					Terminal screw	Mass [kg (lb)]
		W	D	H	W1	X		
MR-J3-DU30K_	MR-DCL30K	135	255	215	80	232	M12	9.5 (20.94)
MR-J3-DU37K_	MR-DCL37K		205	200	75	175	M8	6.5 (14.33)
MR-J3-DU30K_4	MR-DCL30K-4		225		197	7		
MR-J3-DU37K_4	MR-DCL37K-4		240		212	7.5 (16.54)		
MR-J3-DU45K_4	MR-DCL45K-4		260		232	9.5 (20.94)		
MR-J3-DU55K_4	MR-DCL55K-4							

Part 10: Review on Replacement of Optional Peripheral Equipment

7.2 MR-J3/MR-J3W series Power Factor Improving AC Reactor

The power factor improving reactors improve the phase factor by increasing the form factor of servo amplifier's input current.

It can reduce the power capacity.

The input power factor is improved to be about 90%. For use with a 1-phase power supply, it may be slightly lower than 90%.

In addition, it reduces the higher harmonic of input side.

When using power factor improving AC reactors for two or more servo amplifiers, be sure to connect a power factor improving AC reactor to each servo amplifier.

If using only one power factor improving AC reactor, enough improvement effect of phase factor cannot be obtained unless all servo amplifiers are operated.

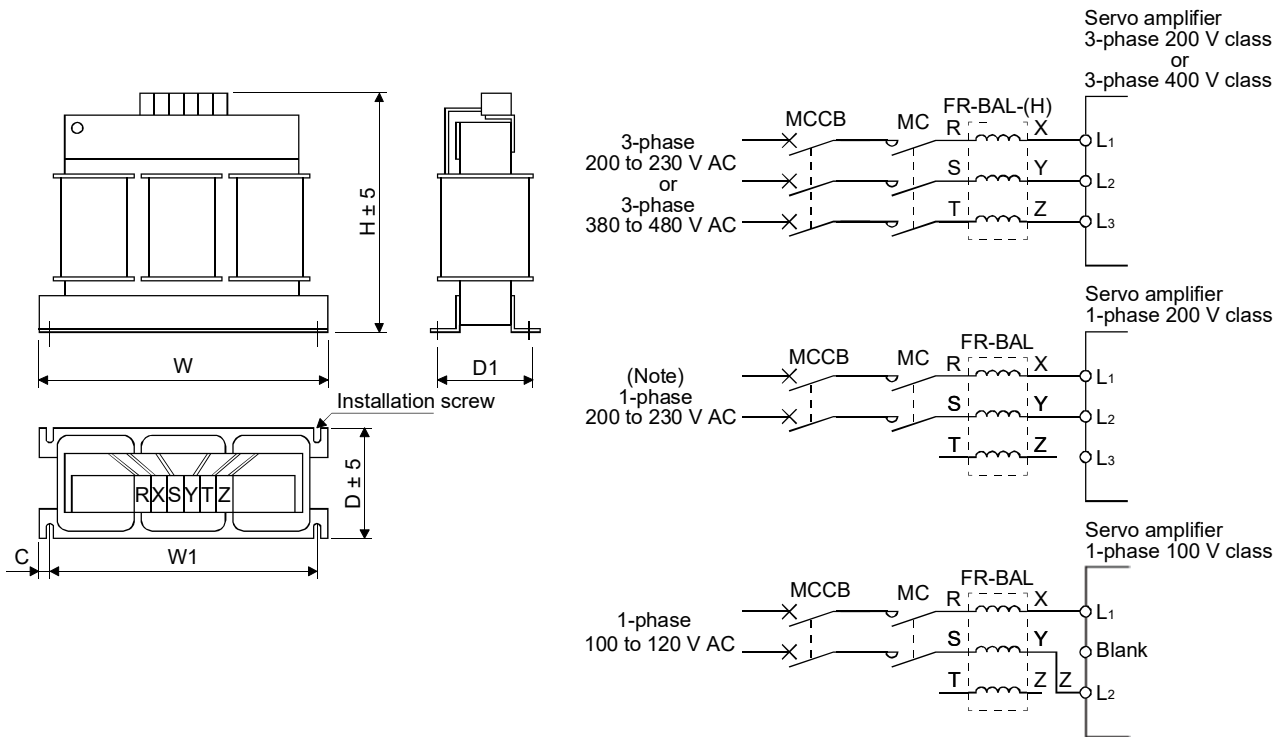

Note. For the 1-phase 200 to 230 V AC power supply, Connect the power supply to L1, L2 and leave L3 open.

Part 10: Review on Replacement of Optional Peripheral Equipment

MR-J3 series

Servo amplifier	Power factor improving AC reactor	Dimensions [mm]						Mounting screw size	Terminal screw size	Mass [kg (lb)]
		W	W1	H	D	D1	C			
MR-J3-10_	FR-BAL-0.4K	135	120	115	59	45 ⁰ _{-2.5}	7.5	M4	M3.5	2.0
MR-J3-10_1										
MR-J3-20_										
MR-J3-20_1	FR-BAL-0.75K	135	120	115	69	57 ⁰ _{-2.5}	7.5	M4	M3.5	2.8
MR-J3-40_										
MR-J3-40_1										
MR-J3-60_	FR-BAL-1.5K	160	145	140	71	55 ⁰ _{-2.5}	7.5	M4	M3.5	3.7
MR-J3-70_										
MR-J3-100_										
MR-J3-200_	FR-BAL-2.2K	160	145	140	91	75 ⁰ _{-2.5}	7.5	M4	M3.5	5.6
MR-J3-350_	FR-BAL-3.7K	220	200	192	90	70 ⁰ _{-2.5}	10	M5	M4	8.5
MR-J3-500_	FR-BAL-7.5K	220	200	194	120	100 ⁰ _{-2.5}	10	M5	M5	14.5
MR-J3-700_	FR-BAL-11K	280	255	220	135	100 ⁰ _{-2.5}	12.5	M6	M6	19
MR-J3-11K_										
MR-J3-15K_										
MR-J3-22K_	FR-BAL-22K	290	240	301	199	170±5	25	M8	M8	35
MR-J3-30K_	FR-BAL-30K	290	240	301	219	190±5	25	M8	M8	43
MR-J3-60_4	FR-BAL-H1.5K	160	145	140	87	70 ⁰ _{-2.5}	7.5	M4	M3.5	5.3
MR-J3-100_4	FR-BAL-H2.2K	160	145	140	91	75 ⁰ _{-2.5}	7.5	M4	M3.5	5.9
MR-J3-200_4	FR-BAL-H3.7K	220	200	190	90	70 ⁰ _{-2.5}	10	M5	M3.5	8.5
MR-J3-350_4	FR-BAL-H7.5K	220	200	192	120	100±5	10	M5	M4	14
MR-J3-500_4	FR-BAL-H11K	280	255	226	130	100±5	12.5	M6	M5	18.5
MR-J3-700_4	FR-BAL-H15K	295	270	244	130	110±5	12.5	M6	M5	27
MR-J3-11K_4										
MR-J3-15K_4										
MR-J3-22K_4	FR-BAL-H22K	290	240	269	199	170±5	25	M8	M8	Approx. 35
	FR-BAL-H30K	290	240	290	219	190±5	25	M8	M8	Approx. 43

MR-J3W series

Total output of rotary servo motor	Power factor improving AC reactor	Dimensions [mm]						Mounting screw size	Terminal screw size	Mass [kg (lb)]
		W	W1	H	D	D1	C			
300 W or less	FR-BAL-0.4K	135	120	115	59	45	7.5	M4	M3.5	2.0 (4.41)
From over 300 W to 450 W	FR-BAL-0.75K	135	120	115	69	57	7.5	M4	M3.5	2.8 (6.17)
From over 450 W to 600 W	FR-BAL-1.5K	160	145	140	71	55	7.5	M4	M3.5	3.7 (8.16)
From over 600 W to 1 kW	FR-BAL-2.2K	160	145	140	91	75	7.5	M4	M3.5	5.6 (12.35)
From over 1 kW to 2.0 kW	FR-BAL-3.7K	220	200	192	90	70 [±] _{2.5}	10	M5	M4	8.5 (18.74)

Part 10: Review on Replacement of Optional Peripheral Equipment

7.3 MR-J4 series Power factor improving DC reactors 200 V class

POINT
● For the 100 V AC power supply type (MR-J4-_A1(-RJ)) and MR-J4W2 series, the power factor improving DC reactor cannot be used.

The following shows the advantages of using power factor improving DC reactor.

- It improves the power factor by increasing the form factor of the servo amplifier's input current.
- It decreases the power supply capacity.
- The input power factor is improved to be about 85%.
- As compared to the power factor improving AC reactor (FR-HAL-(H)), it decreases the loss.

When connecting the power factor improving DC reactor to the servo amplifier, always disconnect P3 and P4. If it remains connected, the effect of the power factor improving DC reactor is not produced.

When used, the power factor improving DC reactor generates heat. To release heat, therefore, leave a 10 cm or more clearance at each of the top and bottom, and a 5 cm or more clearance on each side.

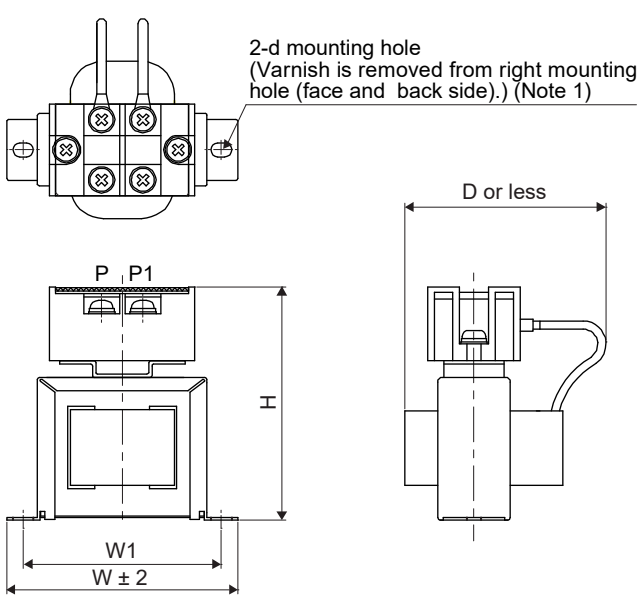

Fig. 10.3

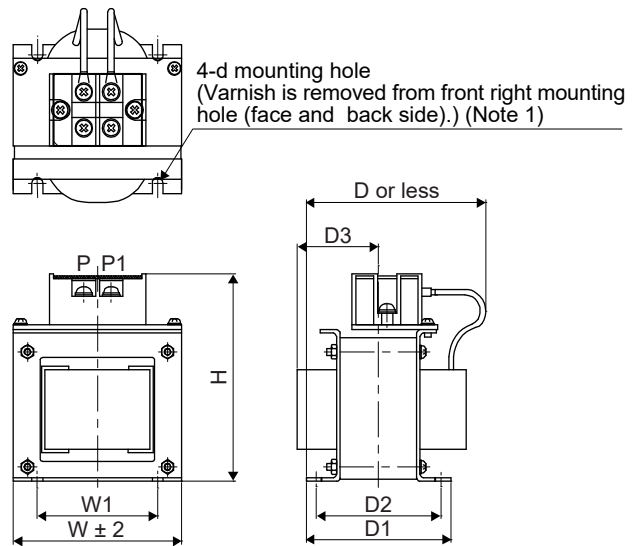

Fig. 10.4

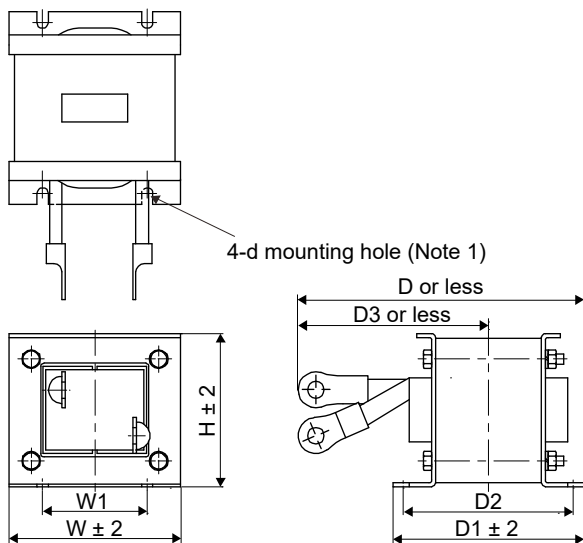
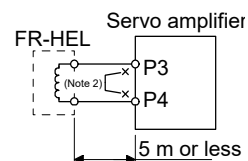

Fig. 10.5



Note 1. Use this for grounding.

Note 2. When using the Power factor improving DC reactor, remove the short bar across P3-P4.

Part 10: Review on Replacement of Optional Peripheral Equipment

Servo amplifier	Power factor improving DC reactor	Outline drawing	Dimensions [mm]							Terminal size	Mass [kg]	Wire [mm ²] (Note 2)			
			W	W1	H	D (Note 1)	D1	D2	D3				d		
MR-J4-10_(-RJ)	FR-HEL-0.4K	Fig. 10.3	70	60	71	61	/	21	/	M4	M4	0.4	2 (AWG 14)		
MR-J4-20_(-RJ)			85	74	81	61		21		M4	M4	0.5			
MR-J4-40_(-RJ)	FR-HEL-0.75K		85	74	81	70		30		M4	M4	0.8			
MR-J4-60_(-RJ)			FR-HEL-1.5K	85	74	81		70		30	M4	M4		0.9	
MR-J4-70_(-RJ)	FR-HEL-2.2K			77	55	92		82		66	57	37		M4	M4
MR-J4-100_(-RJ)			FR-HEL-3.7K	86	60	113		98		81	72	43		M4	M5
MR-J4-200_(-RJ)	Fig. 10.4	105		64	133	112	92	79	47	M6	M6	3.3	5.5 (AWG 10)		
MR-J4-350_(-RJ)		105	64	133	115	97	84	48.5	M6	M6	4.1	8 (AWG 8)			
MR-J4-500_(-RJ)		105	64	133	115	97	84	48.5	M6	M6	4.1	14 (AWG 6)			
MR-J4-700_(-RJ)		105	64	93	175	117	104	115 (Note 1)	M6	M10	5.6	22 (AWG 4)			
MR-J4-11K_(-RJ)	FR-HEL-15K	Fig. 10.5	114	72	100	200	125	101	135 (Note 1)	M6	M10	7.8	38 (AWG 2)		
MR-J4-15K_(-RJ)	FR-HEL-22K		114	72	100	200	125	101	135 (Note 1)	M6	M10	7.8	38 (AWG 2)		
MR-J4-22K_(-RJ)	FR-HEL-30K		114	72	100	200	125	101	135 (Note 1)	M6	M10	7.8	38 (AWG 2)		

- Note 1. Maximum dimensions. The dimension varies depending on the input/output lines.
 Note 2. Selection conditions of wire size are as follows.
 Wire type: 600 V grade heat-resistant polyvinyl chloride insulated wire (HIV wire)
 Construction condition: Single wire set in midair

Part 10: Review on Replacement of Optional Peripheral Equipment

7.4 MR-J4 series Power factor improving DC reactors 400 V class

The following shows the advantages of using power factor improving DC reactor.

- It improves the power factor by increasing the form factor of the servo amplifier's input current.
- It decreases the power supply capacity.
- The input power factor is improved to be about 85%.
- As compared to the power factor improving AC reactor (FR-HAL-(H)), it decreases the loss.

When connecting the power factor improving DC reactor to the servo amplifier, always disconnect P3 and P4. If it remains connected, the effect of the power factor improving DC reactor is not produced.

When used, the power factor improving DC reactor generates heat. To release heat, therefore, leave a 10 cm or more clearance at each of the top and bottom, and a 5 cm or more clearance on each side.

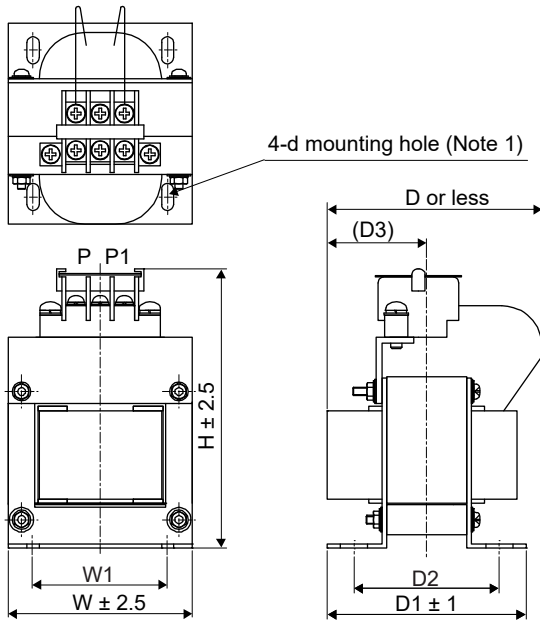

Fig. 10.6

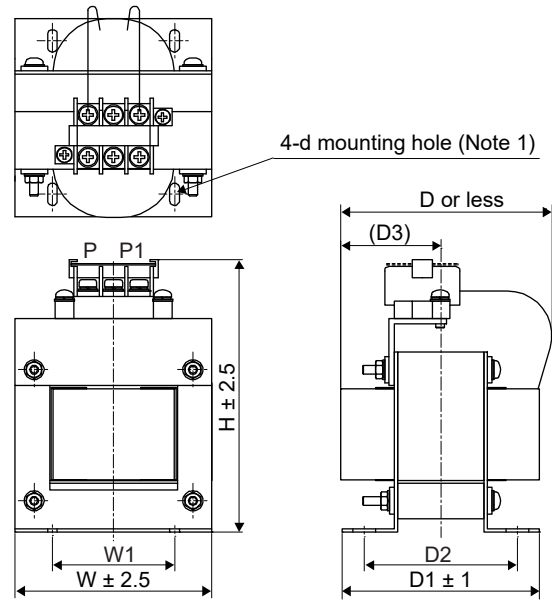

Fig. 10.7

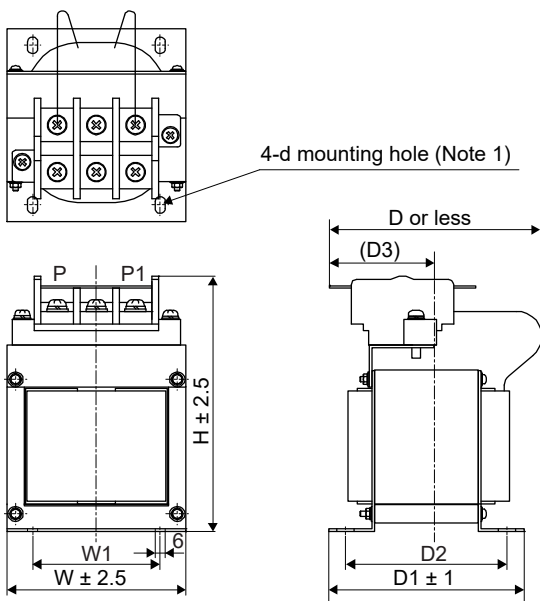
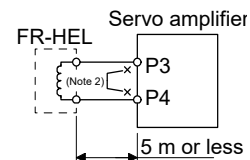

Fig. 10.8



Note 1. Use this for grounding.

Note 2. When using the power factor improving DC reactor, remove the short bar across P3 and P4.

Part 10: Review on Replacement of Optional Peripheral Equipment

Servo amplifier	Power factor improving DC reactor	Outline drawing	Dimensions [mm]								Terminal size	Mass [kg]	Wire [mm ²] (Note)
			W	W1	H	D	D1	D2	D3	d			
MR-J4-60_4(-RJ)	FR-HEL-H1.5K	Fig. 10.6	66	50	100	80	74	54	37	M4	M3.5	1.0	2 (AWG 14)
MR-J4-100_4(-RJ)	FR-HEL-H2.2K		76	50	110	80	74	54	37	M4	M3.5	1.3	2 (AWG 14)
MR-J4-200_4(-RJ)	FR-HEL-H3.7K	Fig. 10.7	86	55	120	95	89	69	45	M4	M4	2.3	2 (AWG 14)
MR-J4-350_4(-RJ)	FR-HEL-H7.5K		96	60	128	105	100	80	50	M5	M4	3.5	2 (AWG 14)
MR-J4-500_4(-RJ)	FR-HEL-H11K	Fig. 10.8	105	75	137	110	105	85	53	M5	M5	4.5	3.5 (AWG 12)
MR-J4-700_4(-RJ)	FR-HEL-H15K		105	75	152	125	115	95	62	M5	M6	5.0	5.5 (AWG 10)
MR-J4-11K_4(-RJ)			8 (AWG 8)										
MR-J4-15K_4(-RJ)	FR-HEL-H22K		133	90	178	120	95	75	53	M5	M6	6.0	8 (AWG 8)
MR-J4-22K_4(-RJ)	FR-HEL-H30K	133	90	178	120	100	80	56	M5	M6	6.5	14 (AWG 6)	

Note. Selection conditions of wire size are as follows.

Wire type: 600 V grade heat-resistant polyvinyl chloride insulated wire (HIV wire)

Construction condition: Single wire set in midair

Part 10: Review on Replacement of Optional Peripheral Equipment

7.5 MR-J4 series Power factor improving AC reactors 200 V/100 V class

The following shows the advantages of using power factor improving AC reactor.

- It improves the power factor by increasing the form factor of the servo amplifier's input current.
- It decreases the power supply capacity.
- The input power factor is improved to be about 80%.

When using power factor improving reactors for two servo amplifiers or more, be sure to connect a power factor improving reactor to each servo amplifier. If using only one power factor improving reactor, enough improvement effect of phase factor cannot be obtained unless all servo amplifiers are operated.

When using the MR-J4W2-_B servo amplifier together with the rotary servo motor, select a power factor improving AC reactor tentatively, assuming one type of the servo motors are used for 2 axes. After the tentative selections are made for all types of the servo motors, use the largest among all power factor improving AC reactors.

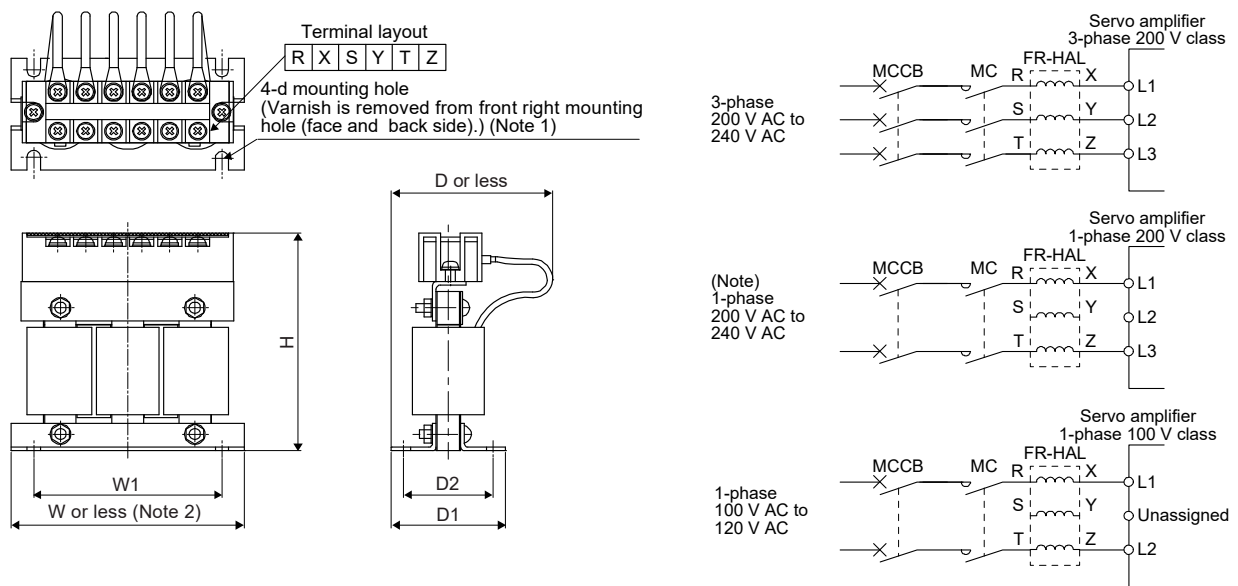

Fig. 10.9

- Note 1. Use this hole for grounding.
 Note 2. $W \pm 2$ is applicable for FR-HAL-0.4K to FR-HAL-1.5K.

Note. For 1-phase 200 V AC to 240 V AC, connect the power supply to L1 and L3. Leave L2 open.

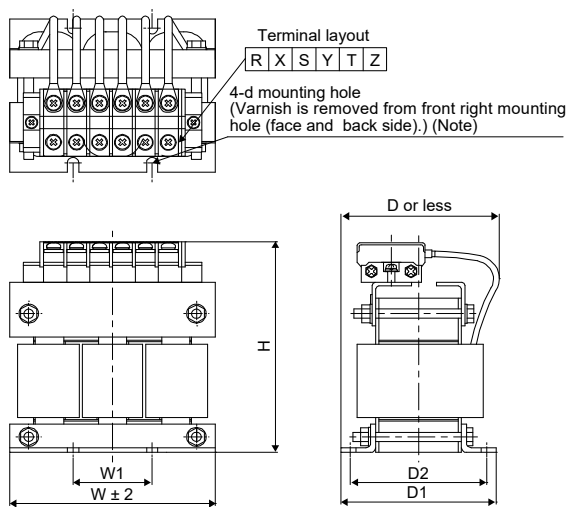

Fig. 10.10

Note. Use this hole for grounding.

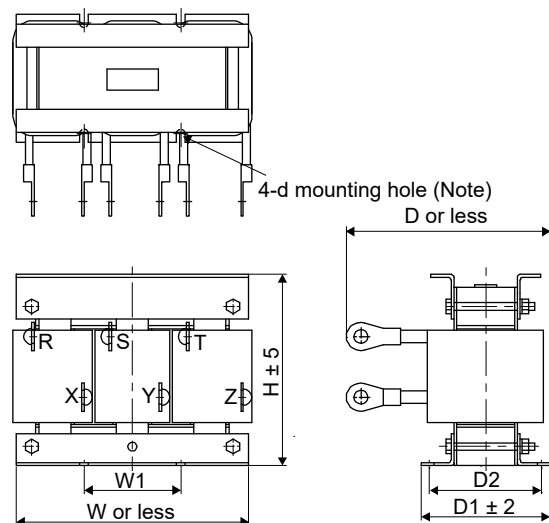

Fig. 10.11

Note. Use this for grounding.

Part 10: Review on Replacement of Optional Peripheral Equipment

Servo amplifier	Power factor improving AC reactor	Outline drawing	Dimensions [mm]							Terminal size	Mass [kg]
			W	W1	H	D (Note)	D1	D2	d		
MR-J4-10_(-RJ) MR-J4-20_(-RJ) MR-J4-10_1(-RJ)	FR-HAL-0.4K	Fig. 10.9	104	84	99	72	51	40	M5	M4	0.6
MR-J4-40_(-RJ) MR-J4-20_1(-RJ)	FR-HAL-0.75K		104	84	99	74	56	44	M5	M4	0.8
MR-J4-60_(-RJ) MR-J4-70_(-RJ) MR-J4-40_1(-RJ)	FR-HAL-1.5K		104	84	99	77	61	50	M5	M4	1.1
MR-J4-100_(-RJ)	FR-HAL-2.2K		115 (Note)	40	115	77	71	57	M6	M4	1.5
MR-J4-200_(-RJ)	FR-HAL-3.7K		115 (Note)	40	115	83	81	67	M6	M4	2.2
MR-J4-350_(-RJ)	FR-HAL-7.5K		Fig. 10.10	130	50	135	100	98	86	M6	M5
MR-J4-500_(-RJ)	FR-HAL-11K	160		75	164	111	109	92	M6	M6	5.2
MR-J4-700_(-RJ)	FR-HAL-15K	160		75	167	126	124	107	M6	M6	7.0
MR-J4-11K_(-RJ)	FR-HAL-15K	160		75	167	126	124	107	M6	M6	7.0
MR-J4-15K_(-RJ)	FR-HAL-22K	185 (Note)		75	150	158	100	87	M6	M8	9.0
MR-J4-22K_(-RJ)	FR-HAL-30K	Fig. 10.11	185 (Note)	75	150	168	100	87	M6	M10	9.7

Note. Maximum dimensions. The dimension varies depending on the input/output lines.

(1) For MR-J4W2-_B servo amplifier

Total output of rotary servo motors	Power factor improving AC reactor
450 W or less	FR-HAL-0.75K
From over 450 W to 600 W	FR-HAL-1.5K
From over 600 W to 1 kW	FR-HAL-2.2K
From over 1 kW to 2.0 kW	FR-HAL-3.7K

Part 10: Review on Replacement of Optional Peripheral Equipment

7.6 MR-J4 series Power factor improving AC reactors 400 V class

The following shows the advantages of using power factor improving AC reactor.

- It improves the power factor by increasing the form factor of the servo amplifier's input current.
- It decreases the power supply capacity.
- The input power factor is improved to be about 80%.

When using power factor improving reactors for two servo amplifiers or more, be sure to connect a power factor improving reactor to each servo amplifier. If using only one power factor improving reactor, enough improvement effect of phase factor cannot be obtained unless all servo amplifiers are operated.

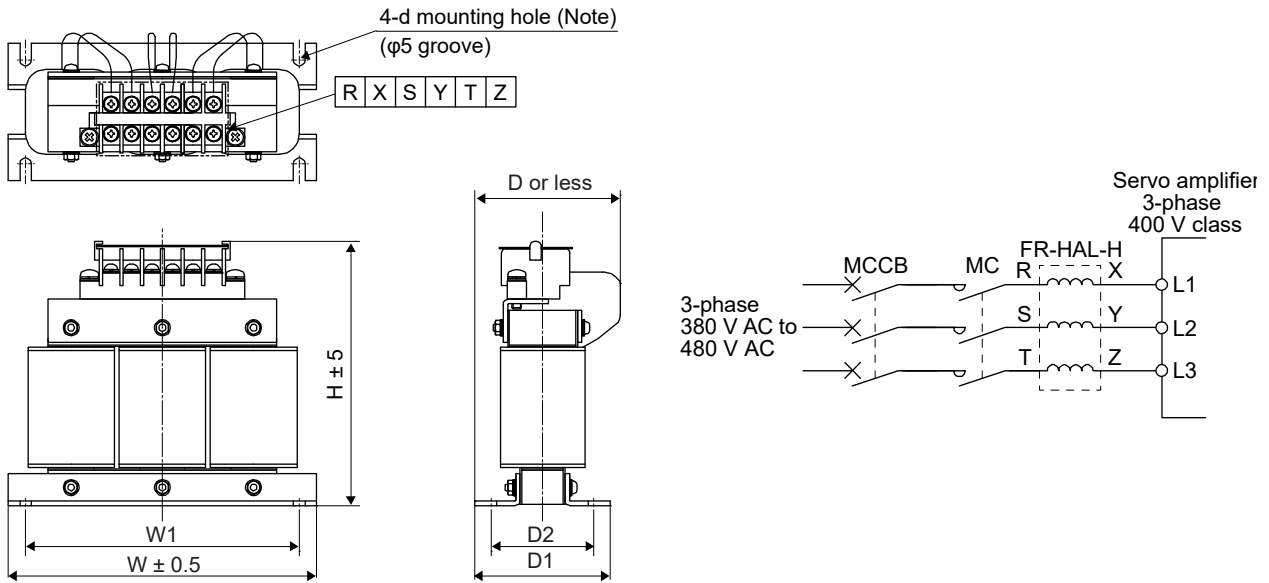

Fig. 10.15

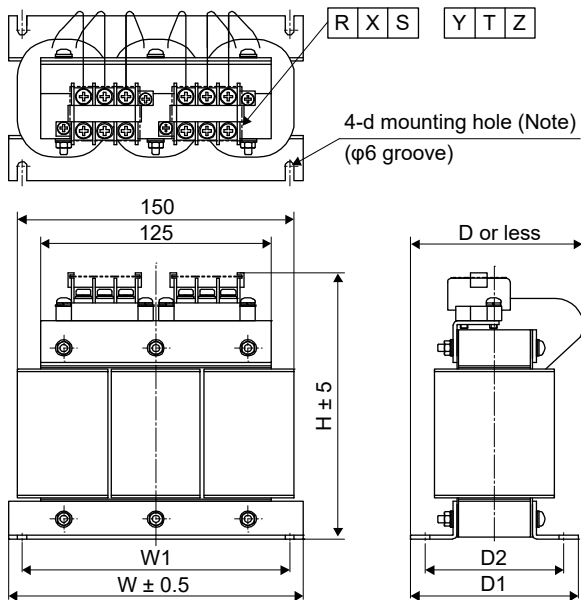

Fig. 10.16

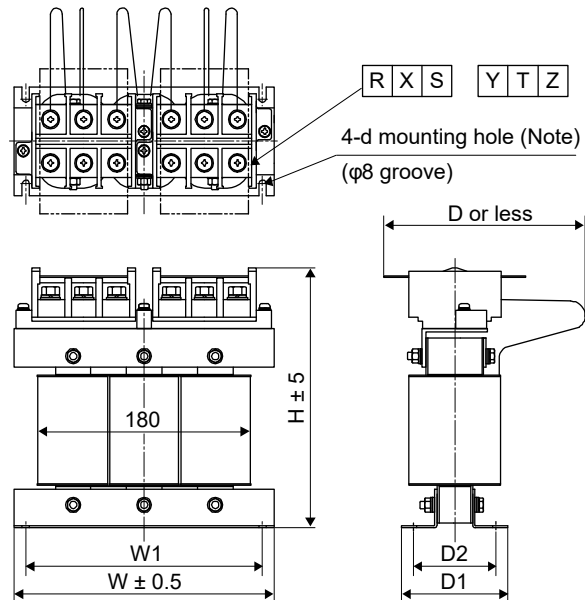

Fig. 10.17

Note. Use this for grounding.

Part 10: Review on Replacement of Optional Peripheral Equipment

Servo amplifier	Power factor improving AC reactor	Outline drawing	Dimensions [mm]							Terminal size	Mass [kg]
			W	W1	H	D (Note)	D1	D2	d		
MR-J4-60_4(-RJ)	FR-HAL-H1.5K	Fig. 10.15	135	120	115	59	59.6	45	M4	M3.5	1.5
MR-J4-100_4(-RJ)	FR-HAL-H2.2K		135	120	115	59	59.6	45	M4	M3.5	1.5
MR-J4-200_4(-RJ)	FR-HAL-H3.7K		135	120	115	69	70.6	57	M4	M3.5	2.5
MR-J4-350_4(-RJ)	FR-HAL-H7.5K	Fig. 10.16	160	145	142	91	91	75	M4	M4	5.0
MR-J4-500_4(-RJ)	FR-HAL-H11K		160	145	146	91	91	75	M4	M5	6.0
MR-J4-700_4(-RJ)	FR-HAL-H15K		220	200	195	105	90	70	M5	M5	9.0
MR-J4-11K_4(-RJ)											
MR-J4-15K_4(-RJ)	FR-HAL-H22K	Fig. 10.17	220	200	215	170	90	70	M5	M8	9.5
MR-J4-22K_4(-RJ)	FR-HAL-H30K		220	200	215	170	96	75	M5	M8	11

Note. Maximum dimensions. The dimension varies depending on the input/output lines.

Part 10: Review on Replacement of Optional Peripheral Equipment

8. SETUP SOFTWARE (SETUP221E)

8.1 MR-J3/MR-J3W series Setup Software (SETUP221E)

The Setup Software (MRZJW3-SETUP221E) uses the communication function of the servo amplifier to perform parameter setting changes, graph display, test operation, etc. on a personal computer.

* MR Configurator2 (SW1DNC-MRC2-E) is available for the MR-J3/MR-J3W series.

8.1.1 Specifications

Item	Description																																																						
Compatibility with a servo amplifier	The following table shows Setup Software (SETUP221E) software version for each servo amplifier.																																																						
	<table border="1"> <thead> <tr> <th rowspan="3">Version</th> <th colspan="6">Compatible servo amplifier (Drive unit)</th> </tr> <tr> <th colspan="3">200 V class</th> <th colspan="3">400 V class</th> </tr> <tr> <th>7 kW or less</th> <th>11 to 22 kW</th> <th>30 to 37 kW</th> <th>7 kW or less</th> <th>11 to 22 kW</th> <th>30 to 55 kW</th> </tr> </thead> <tbody> <tr> <td>B0 to B2</td> <td style="text-align: center;">○</td> <td style="text-align: center;">/</td> <td style="text-align: center;">/</td> <td style="text-align: center;">/</td> <td style="text-align: center;">/</td> <td style="text-align: center;">/</td> </tr> <tr> <td>B3</td> <td style="text-align: center;">○</td> <td style="text-align: center;">/</td> <td style="text-align: center;">/</td> <td style="text-align: center;">/</td> <td style="text-align: center;">/</td> <td style="text-align: center;">/</td> </tr> <tr> <td>B4</td> <td style="text-align: center;">○</td> <td style="text-align: center;">○</td> <td style="text-align: center;">/</td> <td style="text-align: center;">/</td> <td style="text-align: center;">○</td> <td style="text-align: center;">/</td> </tr> <tr> <td>B5</td> <td style="text-align: center;">○</td> <td style="text-align: center;">○</td> <td style="text-align: center;">○</td> <td style="text-align: center;">/</td> <td style="text-align: center;">○</td> <td style="text-align: center;">○</td> </tr> <tr> <td>B8 or later</td> <td style="text-align: center;">○</td> <td style="text-align: center;">○</td> <td style="text-align: center;">○</td> <td style="text-align: center;">○</td> <td style="text-align: center;">○</td> <td style="text-align: center;">○</td> </tr> </tbody> </table> <p style="text-align: right;">○: Enabled</p>	Version	Compatible servo amplifier (Drive unit)						200 V class			400 V class			7 kW or less	11 to 22 kW	30 to 37 kW	7 kW or less	11 to 22 kW	30 to 55 kW	B0 to B2	○	/	/	/	/	/	B3	○	/	/	/	/	/	B4	○	○	/	/	○	/	B5	○	○	○	/	○	○	B8 or later	○	○	○	○	○	○
	Version		Compatible servo amplifier (Drive unit)																																																				
200 V class			400 V class																																																				
7 kW or less		11 to 22 kW	30 to 37 kW	7 kW or less	11 to 22 kW	30 to 55 kW																																																	
B0 to B2	○	/	/	/	/	/																																																	
B3	○	/	/	/	/	/																																																	
B4	○	○	/	/	○	/																																																	
B5	○	○	○	/	○	○																																																	
B8 or later	○	○	○	○	○	○																																																	
	<table border="1"> <thead> <tr> <th>Version</th> <th>MR-J3W series servo amplifier</th> </tr> </thead> <tbody> <tr> <td>CO or later (Note1)</td> <td style="text-align: center;">○</td> </tr> </tbody> </table>	Version	MR-J3W series servo amplifier	CO or later (Note1)	○																																																		
Version	MR-J3W series servo amplifier																																																						
CO or later (Note1)	○																																																						
Baud rate [bps]	115200/57600/38400/19200/9600																																																						
Monitor	Display all, high-speed display, graph display (Minimum resolution changes with the processing speed of the personal computer.)																																																						
Alarm	Display, history, amplifier data																																																						
Diagnosis	DI/DO display, display of the reason for no rotation, power ON cumulative display, software No. display, motor information display, tuning data display, ABS data display, VC automatic offset display, axis name setting																																																						
Parameter	Parameter list, turning, change list, detailed information																																																						
Test operation	JOG operation, positioning operation, motor-less operation, DO forced output, and program operation																																																						
Advanced function (Note2)	Machine analyzer, gain search, machine simulation, robust disturbance compensation, advanced Gain search																																																						
File operation	Data read, save, delete, print																																																						
Others	Automatic demo, help display																																																						

Note 1. C3 or later software version is recommended.

2. The advanced gain search is supported by MR Configurator with software version C2 or later.

Part 10: Review on Replacement of Optional Peripheral Equipment

8.2 MR-J4 series MR Configurator2

MR Configurator2 (SW1DNC-MRC2-E) uses the communication function of the servo amplifier to perform parameter setting changes, graph display, test operation, etc. on a personal computer.

8.2.1 Specifications

Item	Description
Project	Create/read/save/delete project, system setting, and print
Parameter	Parameter setting, axis name setting, parameter converter
Monitor	Display all, I/O monitor, graph, and ABS data display
Diagnosis	Alarm display, alarm onset data, drive recorder, no motor rotation, system configuration, life diagnosis, machine diagnosis
Test operation	Positioning operation, motor-less operation (Note), DO forced output, and program operation, test mode information
Adjustment	One-touch tuning, tuning, and machine analyzer
Others	Servo assistant, parameter setting range update, help display

Note. This is available only in the standard control mode.

Part 10: Review on Replacement of Optional Peripheral Equipment

8.3 System configuration

8.3.1 Components

MR Configurator2 (SW1DNC-MRC2-E) the following components are required in addition to the servo amplifier and servo motor.

Equipment		Description (Note 1)
Personal computer (Note 2, 3, 4, 5)	OS	Microsoft® Windows® 10 Home Operating System Microsoft® Windows® 10 Pro Operating System Microsoft® Windows® 10 Enterprise Operating System Microsoft® Windows® 10 Education Operating System Microsoft® Windows® 8.1 Operating System Microsoft® Windows® 8.1 Pro, Operating System Microsoft® Windows® 8.1 Enterprise Operating System Microsoft® Windows® 8 Operating System Microsoft® Windows® 8 Pro Operating System Microsoft® Windows® 8 Enterprise Operating System Microsoft® Windows® 7 Starter Operating System Microsoft® Windows® 7 Home Premium Operating System Microsoft® Windows® 7 Professional Operating System Microsoft® Windows® 7 Ultimate Operating System Microsoft® Windows® 7 Enterprise Operating System
	CPU	Desktop personal computer: Intel® Celeron® processor, 2.8 GHz or more recommended Laptop personal computer: Intel® Pentium® M processor, 1.7 GHz or more recommended
	Memory	1 GB or more (for 32-bit OS) and 2 GB or more (for 64-bit OS)
	Hard Disk	1.5 GB or more of free space
	Communication interface	USB port (Note 6).
Browser	Windows® Internet Explorer® 4.0 or later (Note 1)	
Display	One whose resolution is 1024 × 768 or more and that can provide a high color (16 bit) display. Connectable with the above personal computer.	
Keyboard	Connectable with the above personal computer.	
Mouse	Connectable with the above personal computers.	
Printer	Connectable with the above personal computer.	
USB cable	MR-J3USBCBL3M	

Note 1. Microsoft, Windows and Internet Explorer are registered trademarks or trademarks of Microsoft Corporation in the United States and other countries.

Celeron, Pentium is the registered trademarks of Intel Corporation.

2. When Windows® 7 or later is used, NET Framework 3.5 (including .NET2.0 and 3.0) must be enabled.
3. When the following functions are used, this product may not operate correctly.
 - Windows® Program Compatibility mode
 - Remote Desktop
 - Windows touch or touch
 - Client Hyper-V
 - Virtual desktop
 - Fast User Switching
 - Windows XP Mode
 - Modern UI
 - Tablet mode
4. In the following cases, the display of this product may not operate correctly.
 - The size of the text or other items on the screen is set to other than the prescribed value (96DPI, 100%. 9pt, etc.).
 - Resolution of the screen is changed during operation.
 - The screen is set as multi display.
5. When using this software with Windows® 7 or later, log in as "Standard user" or "Administrator".
6. 64-bit Windows is not supported.

Part 10: Review on Replacement of Optional Peripheral Equipment

8.3.2 Connection with servo amplifier

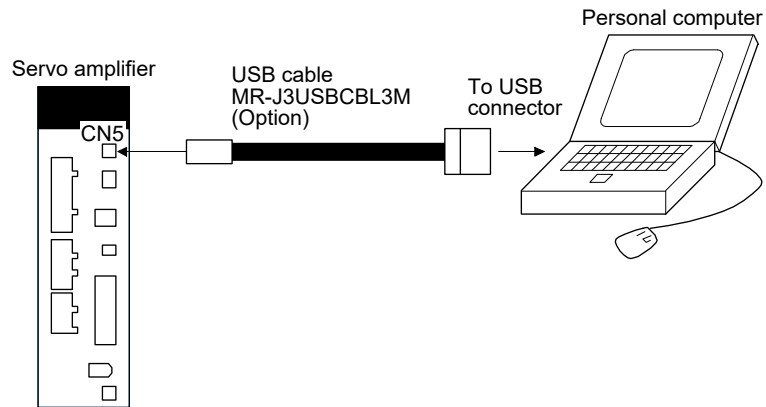

8.3.3 Precautions for using USB communication function

Note the following to prevent an electric shock and malfunction of the servo amplifier.

(1) Power connection of personal computers

Connect your personal computer with the following procedures.

(a) When you use a personal computer with AC power supply

- 1) When using a personal computer with a three-core power plug or power plug with grounding wire, use a three-pin socket or ground the grounding wire.
- 2) When your personal computer has two-core plug and has no grounding wire, connect the personal computer to the servo amplifier with the following procedures.
 - a) Disconnect the power plug of the personal computer from an AC power socket.
 - b) Check that the power plug was disconnected and connect the device to the servo amplifier.
 - c) Connect the power plug of the personal computer to the AC power socket.

(b) When you use a personal computer with battery

You can use as it is.

(2) Connection with other devices using servo amplifier communication function

When the servo amplifier is charged with electricity due to connection with a personal computer and the charged servo amplifier is connected with other devices, the servo amplifier or the connected devices may malfunction. Connect the servo amplifier and other devices with the following procedures.

- (a) Shut off the power of the device for connecting with the servo amplifier.
- (b) Shut off the power of the servo amplifier which was connected with the personal computer and check the charge lamp is off.
- (c) Connect the device with the servo amplifier.
- (d) Turn on the power of the servo amplifier and the device.

Part 10: Review on Replacement of Optional Peripheral Equipment

9. PANEL THROUGH ATTACHMENT

POINT		
●MR-J3ACN can be used only for MR-J4-22K_(4).		
Panel through attachment	MR-J3 series	MR-J4 series
MR-J4ACN15K		MR-J4-11K_(4)(-RJ) MR-J4-15K_(4)(-RJ)
MR-J3ACN	MR-J3-11K_(4) to MR-J3-22K_(4)	MR-J4-22K_(4)(-RJ)

9.1 MR-J3 series (MR-J3ACN)

Use the Panel through attachment to mount the heat generation area of the servo amplifier in the outside of the control box to dissipate servo amplifier-generated heat to the outside of the box and reduce the amount of heat generated in the box, thereby allowing a compact control box to be designed.

In the control box, machine a hole having the panel cut dimensions, fit the panel through attachment to the servo amplifier with the fitting screws (4 screws supplied), and install the servo amplifier to the control box. The environment outside the control box when using the panel through attachment should be within the range of the servo amplifier operating environment conditions.

(1) Panel cut dimensions

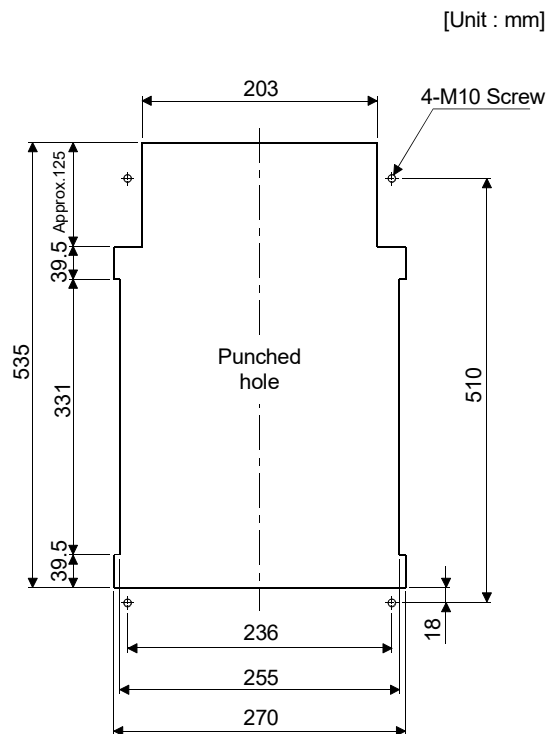

(2) How to assemble the attachment for a panel through attachment

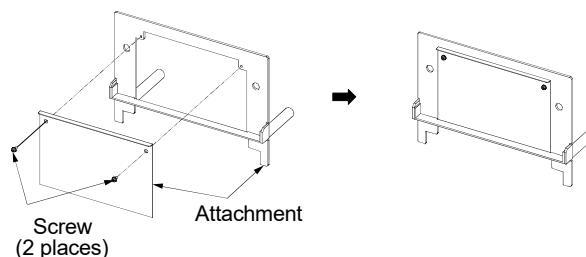

Part 10: Review on Replacement of Optional Peripheral Equipment

(3) Fitting method

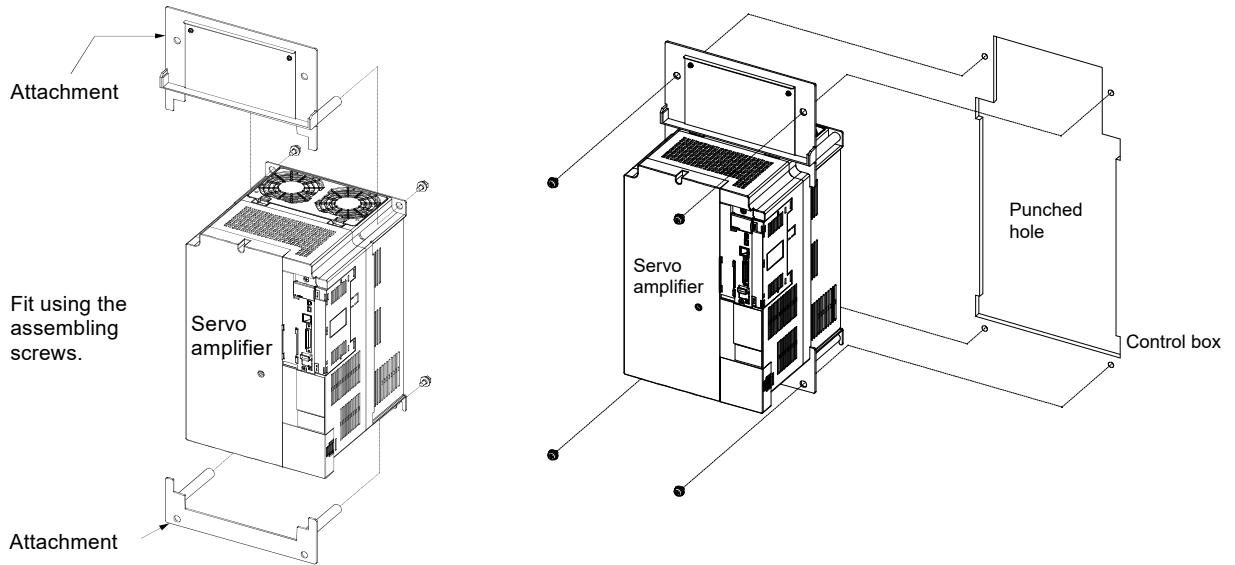

a. Assembling the panel through attachment

b. Installation to the control box

(4) Outline dimension drawing

[Unit: mm]

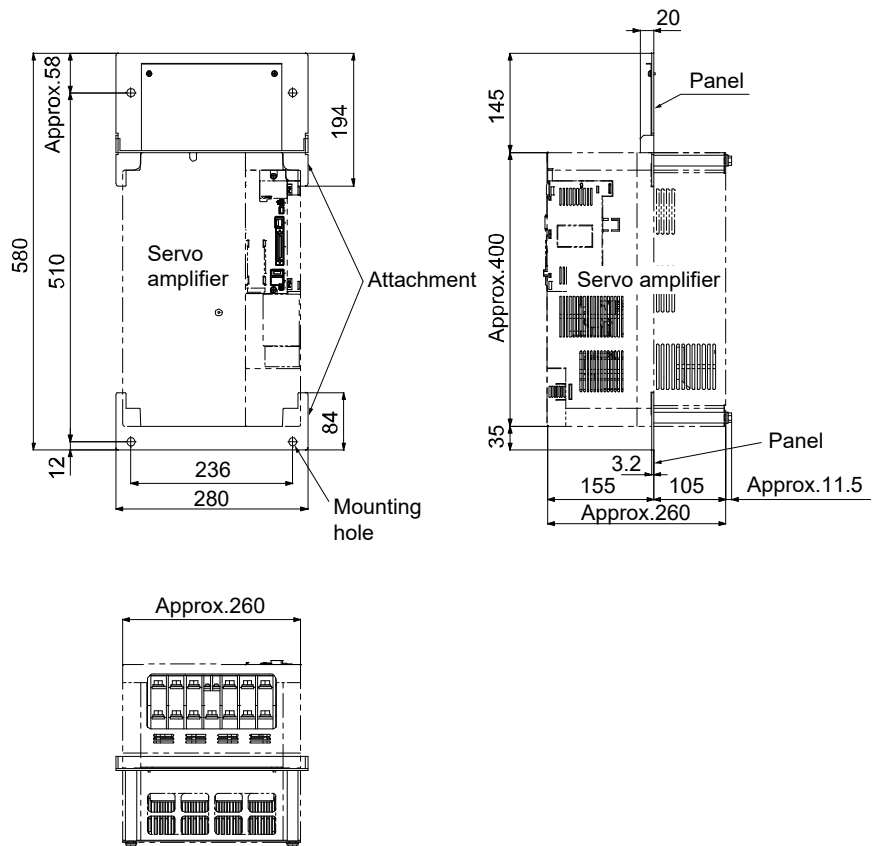

Part 10: Review on Replacement of Optional Peripheral Equipment

9.2 MR-J4 series (MR-J4ACN15K/MR-J3ACN)

Use the panel through attachment to mount the heat generation area of the servo amplifier in the outside of the cabinet to dissipate servo amplifier-generated heat to the outside of the cabinet and reduce the amount of heat generated in the cabinet. In addition, designing a compact cabinet is allowed.

In the cabinet, machine a hole having the panel cut dimensions, fit the panel through attachment to the servo amplifier with the fitting screws (4 screws supplied), and install the servo amplifier to the cabinet.

Please prepare screws for mounting. They do not come with.

The environment outside the cabinet when using the panel through attachment should be within the range of the servo amplifier operating environment.

The panel through attachments are used for MR-J4-11K_(-RJ) to MR-J4-22K_(-RJ) and MR-J4-11K_4(-RJ) to MR-J4-22K_4(-RJ).

The following shows the combinations.

Servo amplifier	Panel through attachment
MR-J4-11K_(-RJ) MR-J4-15K_(-RJ)	MR-J4ACN15K
MR-J4-22K_(-RJ)	MR-J3ACN
MR-J4-11K_4(-RJ) MR-J4-15K_4(-RJ)	MR-J4ACN15K
MR-J4-22K_4(-RJ)	MR-J3ACN

(1) MR-J4ACN15K

(a) Panel cut dimensions

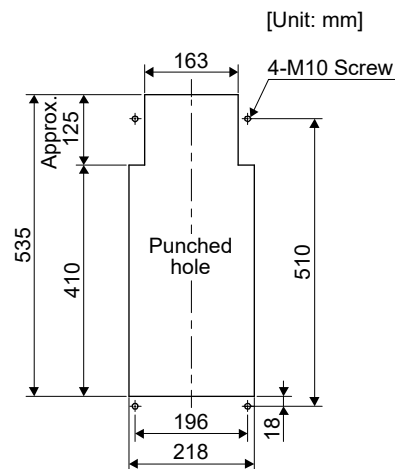

(b) How to assemble the attachment for panel through attachments

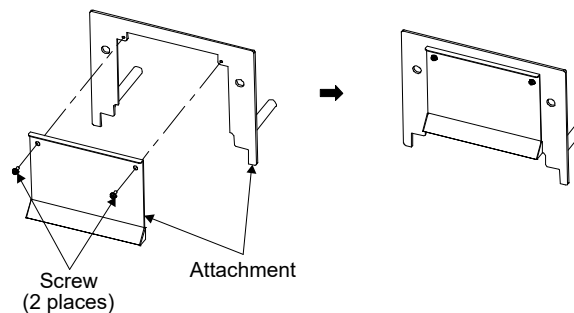

Part 10: Review on Replacement of Optional Peripheral Equipment

(c) Mounting method

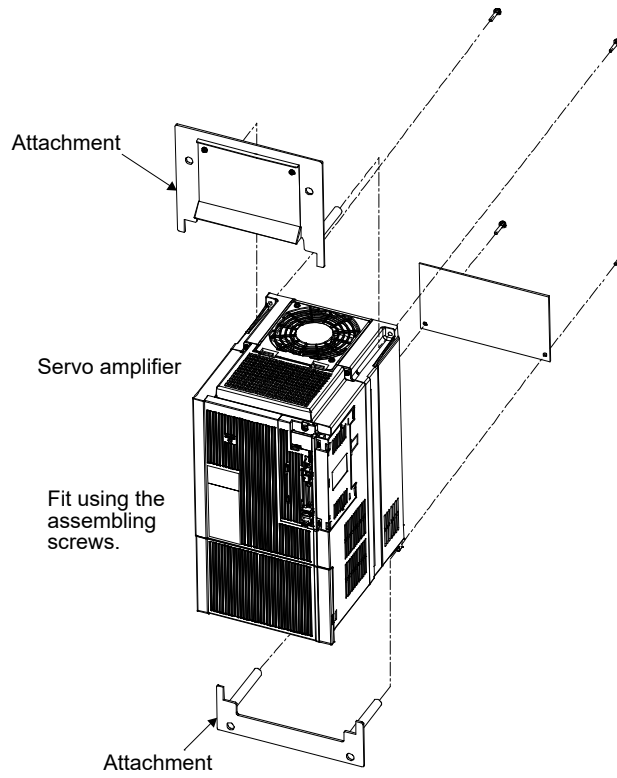

a. Assembling the panel through attachment

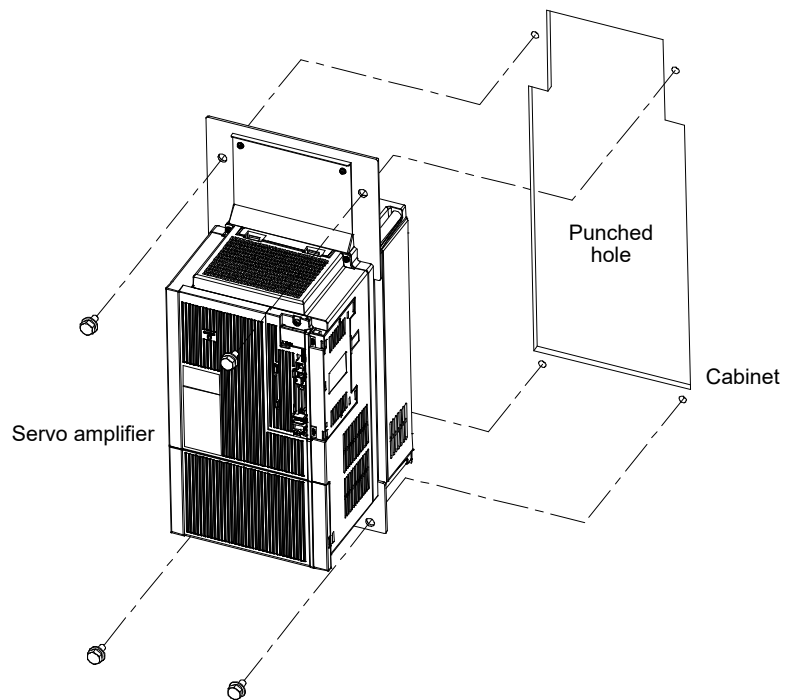

b. Mounting it to inside cabinet

Part 10: Review on Replacement of Optional Peripheral Equipment

(d) Mounting dimensional diagram

[Unit: mm]

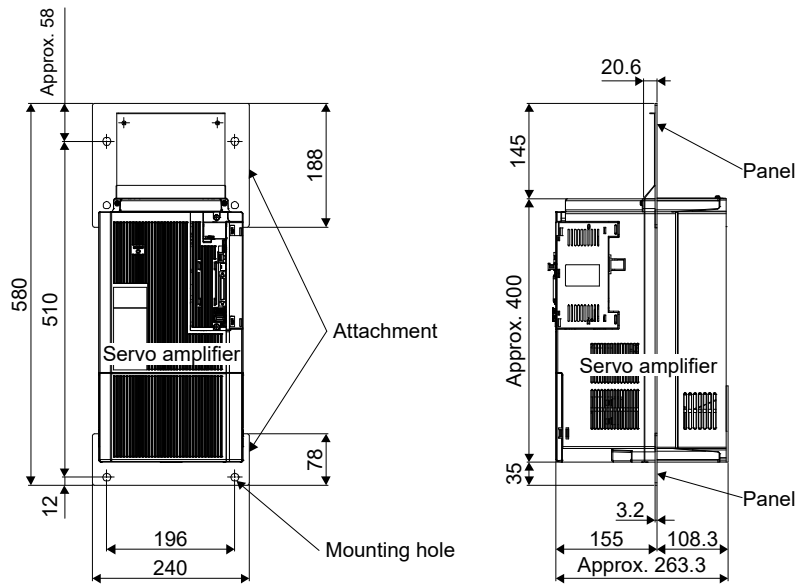

(2) MR-J3ACN

(a) Panel cut dimensions

[Unit : mm]

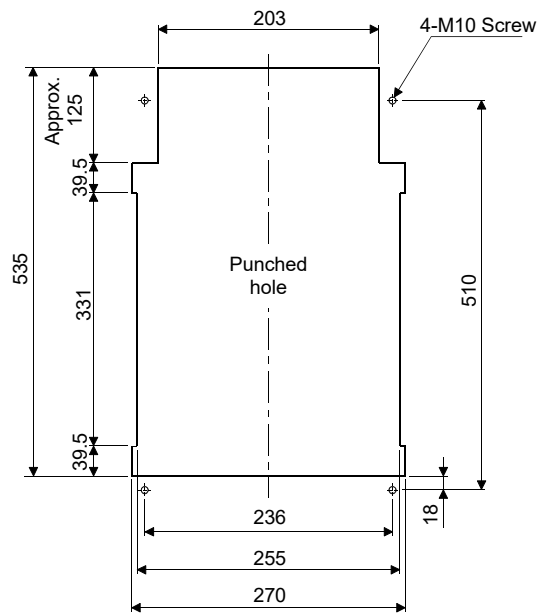

(b) How to assemble the attachment for panel through attachment

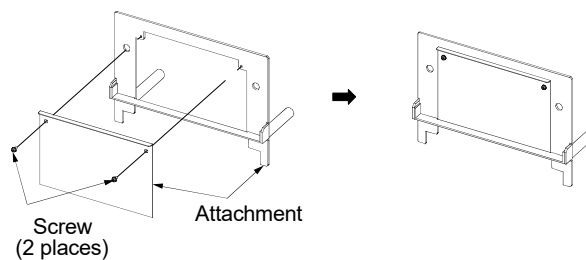

Part 10: Review on Replacement of Optional Peripheral Equipment

(c) Mounting method

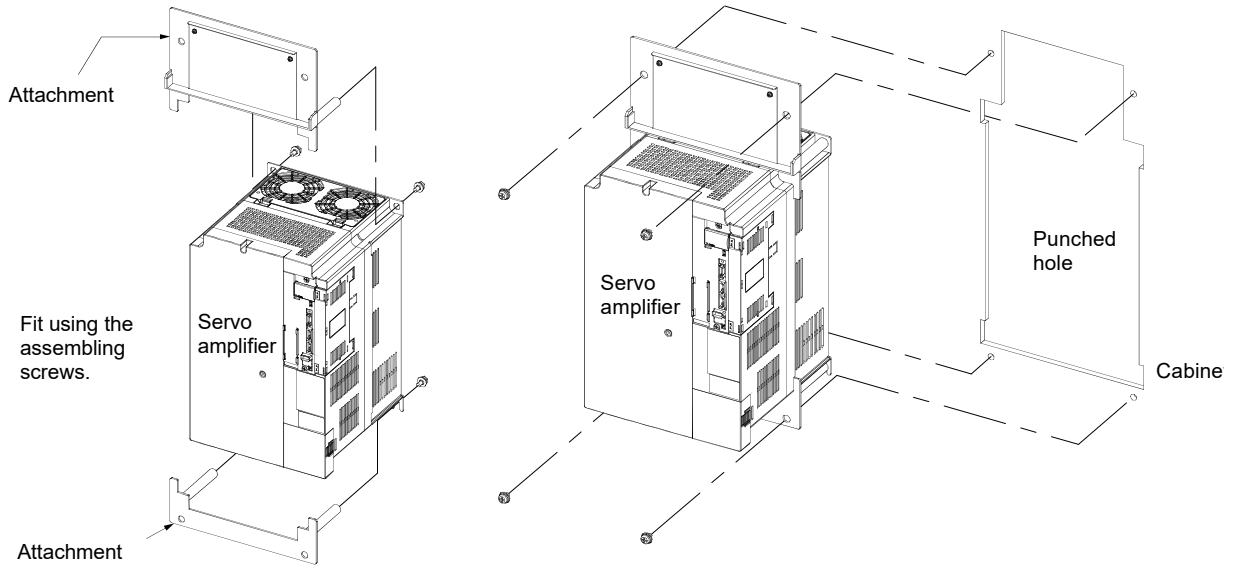

a. Assembling the panel through attachment

b. Mounting it to inside cabinet

(d) Mounting dimensional diagram

[Unit: mm]

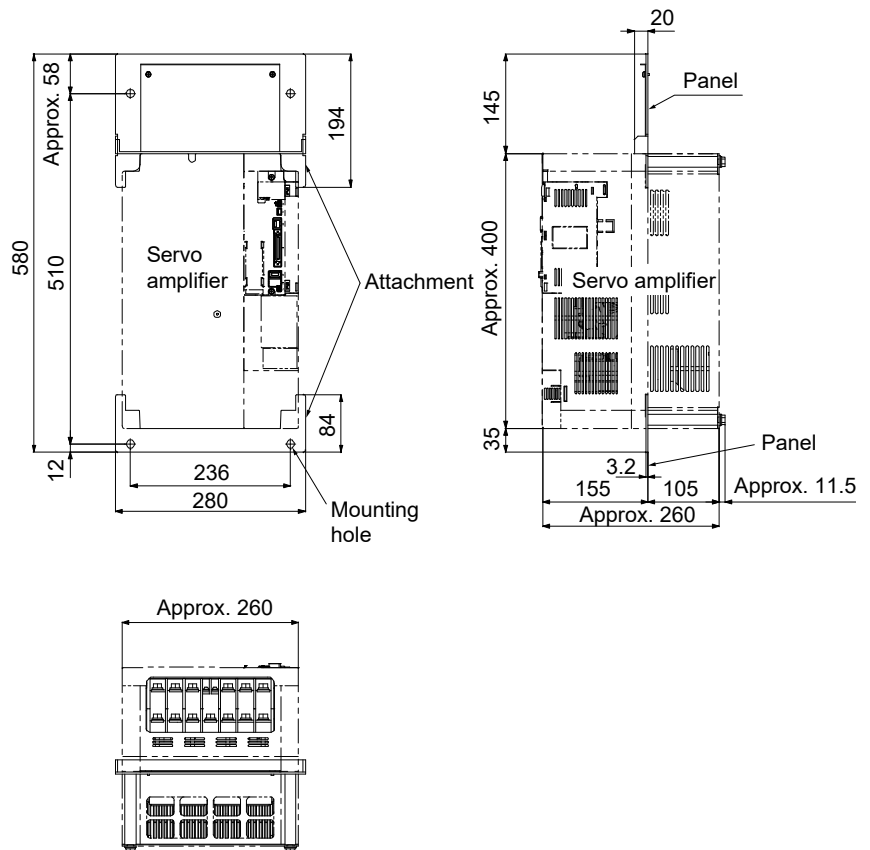

Part 11

Startup Procedure Manual

Part 11: Startup Procedure Manual

1. STARTUP



WARNING

- When executing a test run, follow the notice and procedures in this instruction manual. Otherwise, it may cause a malfunction, damage to the machine, or injury.
- Do not operate the switches with wet hands. Otherwise, it may cause an electric shock.



CAUTION

- Before starting operation, check the parameters. Improper settings may cause some machines to operate unexpectedly.
- The servo amplifier heat sink, regenerative resistor, servo motor, etc., may be hot while power is on or for some time after power-off. Take safety measures, example, provide covers to avoid accidentally touching the parts (cables, etc.) by hand. Otherwise, it may cause a burn injury and parts damaged.
- During operation, never touch the rotor of the servo motor. Otherwise, it may cause injury.
- Before wiring, switch operation, etc., eliminate static electricity. Otherwise, it may cause a malfunction.

Part 11: Startup Procedure Manual

1.1 Switching power on for the first time

When switching power on for the first time, follow this section to make a startup.

1.1.1 Startup procedure

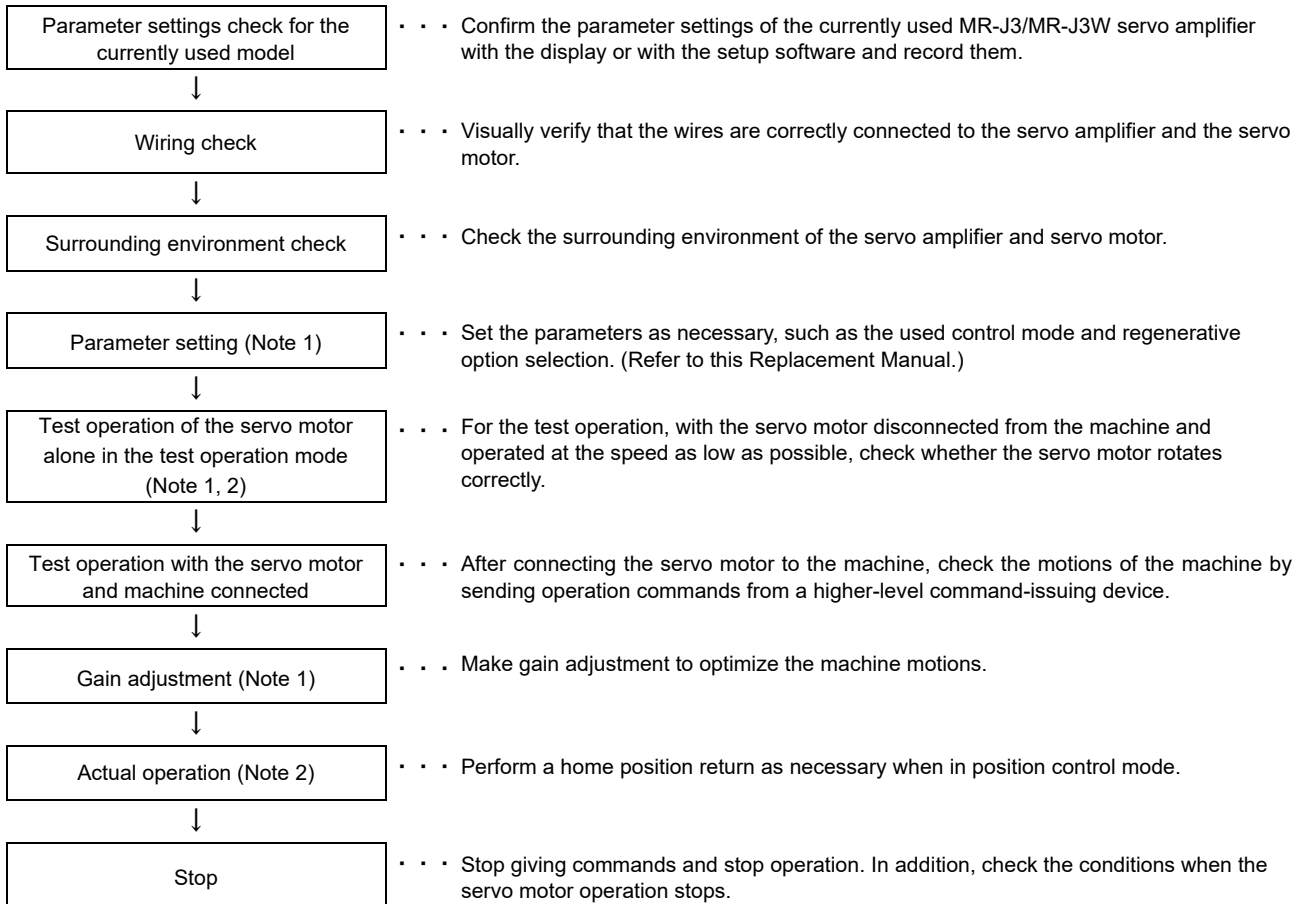

Note 1. For details about the settings for each servo amplifier and its test operation, refer to the applicable servo amplifier instruction manual. If the gain of the existing servo amplifier is extremely high, there may be slight differences in characteristics upon primary replacement. Make sure to set the gain again.

2. When turning on the power supply, also turn on the 24V DC power supply for the external interface. Otherwise, [AL. E6.1 Forced stop warning] occurs.

[Appendix 1] Introduction to Renewal Tool

Mitsubishi Electric System & Service Co., Ltd. provides the related services.
For details, please refer to the following address.

 **Mitsubishi Electric System & Service Co., Ltd.**

<http://www.melsc.co.jp/business/>

OVERSEAS SERVICE SUPPORT SECTION

Email: osb.webmaster@melsc.jp

【Appendix 1】 Introduction to Renewal Tool

[Appendix 1] Introduction to Renewal Tool

POINT
<ul style="list-style-type: none"> ● For details and the latest version of the tool and compatible models, check the website of Mitsubishi Electric System & Service Co., Ltd. ● This appendix lists only products that can be replaced using the renewal tool released by Mitsubishi Electric System & Service Co., Ltd. For products not listed, refer to this chapter in this replacement guide.

1. SUMMARY

The MR-J3 renewal tool is a tool to replace the presently used "MR-J3 series", "MR-J3W series" servo amplifier with the "MR-J4 series" servo amplifier. We are prepared to provide mounting attachments compatible with the existing mounting dimensions and conversion cables compatible with the existing cables.

1.1 Servo amplifier replacement model

Type	Former model	Replacement (Note 1)
General-purpose interface	MR-J3- _A_	MR-J4- _A_
SSCNETIII interface	MR-J3- _B_	MR-J4- _B_
	MR-J3W- _B	MR-J4W2- _B
DIO command with built-in positioning function (Note 2, 3)	MR-J3- _T_ + MR-J3-D01	MR-J4- _A_ -RJ + MR-J3-D01 (Note 4, 5)

- Note
1. For servo amplifiers of 3.5 kW or less, it is necessary to change the power connectors CNP1, CNP2, and CNP3 to the MR-J4 servo amplifier accessories. (Except for MR-J4W2- _B)
 2. If using serial communication operation with the MR-J3- _T_ series, refer to "Part 6: Review on Replacement of MR-J3- _T_ (DIO Command/Serial Communication Operation) with MR-J4- _A_ -RJ".
 3. If using the CC-Link function with the MR-J3- _T_ series, refer to "Part 7: Review on Replacement of MR-J3- _T_ (CC-Link communication operation) with MR-J4- _GF_".
 4. MR-J3-D01 used in the MR-J3- _T_ series can also be used with MR-J4- _A_ -RJ.
 5. If using the DIO command with the MR-J3- _T_ series, contact your branch/local office listed in Appendix 1-1.

1.2 Features

- Wiring work can be shortened because the existing cables can be connected as they are. (except for some models)
- The renewal kit can be mounted using the existing mounting holes.

【Appendix 1】 Introduction to Renewal Tool

2. IMPORTANT POINTS TO NOTE WHEN REPLACING

- (1) Depending on the condition of the existing setup, sometimes noise reduction techniques are necessary when replacing.
- (2) When using the existing cables, please consider the remaining life of the cables. If deterioration is significant, replacing with a new cable is recommended.
- (3) Because the conversion cable does not have a long bending life, fix the cable when using.
- (4) When using the control signal conversion cable "SC-J3WJ4WCTC03M", refer to the cable connection diagram in section 6.2.5.
- (5) Contact a Mitsubishi Electric. if the existing MR-J3 servo amplifier or servo motor is a special product.
- (6) When replacing the servo motor (secondary replacement) after replacing only the servo amplifier (primary replacement), there are some combinations by which the capacity of the servo amplifier changes. In that case, batch replacement (simultaneous replacement of the servo amplifier and servo motor) is recommended.

【Appendix 1】 Introduction to Renewal Tool

3. REPLACEMENT COMBINATION LIST

3.1 Servo amplifier replacement combination list

POINT
<ul style="list-style-type: none"> ● Check the website of Mitsubishi Electric System & Service Co., Ltd. for the latest details and models. ● For servo amplifier models not listed in the table, refer to "Part 1: 3.2.2 Determining the basic replacement model". ● Refer to Appendix 1-5 for notes. ● The capacity of the servo amplifier may change depending on the servo motor to be replaced, thereby being unable to mount the servo motor using the mounting attachment and other instructions specified below. For the target combinations, refer to the servo amplifier capacity compatibility column in "3.2 Servo Motor Substitute Model and Compatibility" in this appendix.

(1) MR-J3 series to MR-J4 series replacement models and renewal tools

(a) General-purpose interface/SSCNET interface 200 V class

Model	Replacement model example	Connector compatibility		Mounting compatibility	Conversion cable	Mounting attachment
		Power supply	Command			
MR-J3-500_	MR-J4-500_	(Note 1)	○	(Note 2)	/	SC-J2SJ4BS04
MR-J3-11K_	MR-J4-11K_	○	○	(Note 2)		SC-J2SJ4BS06
MR-J3-11K_-LR						
MR-J3-15K_	MR-J4-15K_	○	○	(Note 2)		
MR-J3-15K_-LR						

(b) DIO command/serial communication 200 V class

Model (Note 3)	Replacement model example (Note 4)	Connector compatibility		Mounting compatibility	Conversion cable	Mounting attachment	
		Power supply	Command				
MR-J3-10T	MR-J4-10A-RJ	(Note 5)	(Note 6)	○	(Note 6)	/	
MR-J3-20T	MR-J4-20A-RJ	(Note 5)	(Note 6)	○			
MR-J3-40T	MR-J4-40A-RJ	(Note 5)	(Note 6)	○			
MR-J3-60T	MR-J4-60A-RJ	(Note 5)	(Note 6)	○			
MR-J3-70T	MR-J4-70A-RJ	(Note 5)	(Note 6)	○			
MR-J3-100T	MR-J4-100A-RJ	(Note 5)	(Note 6)	○			
MR-J3-200TN	MR-J4-200A-RJ	(Note 5)	(Note 6)	○			
MR-J3-350T	MR-J4-350A-RJ	(Note 5)	(Note 6)	○			
MR-J3-500T	MR-J4-500A-RJ	(Note 1)	(Note 6)	(Note 2)			SC-J2SJ4BS04
MR-J3-700T	MR-J4-700A-RJ	○	(Note 6)	○			/
MR-J3-11KT	MR-J4-11KA-RJ	○	(Note 6)	(Note 2)			
MR-J3-15KT	MR-J4-15KA-RJ	○	(Note 6)	(Note 2)			
MR-J3-22KT	MR-J4-22KA-RJ	○	(Note 6)	○		SC-J2SJ4BS06	

(c) General-purpose interface/SSCNET interface 400 V class

Model	Replacement model example	Connector compatibility		Mounting compatibility	Conversion cable	Mounting attachment
		Power supply	Command			
MR-J3-350_4	MR-J4-350_4	(Note 5)	○	(Note 2)	/	SC-J2SJ4BS04
MR-J3-11K_4	MR-J4-11K_4	○	○	(Note 2)		SC-J2SJ4BS06
MR-J3-11K_4-LR						
MR-J3-15K_4	MR-J4-15K_4	○	○	(Note 2)		
MR-J3-15K_4-LR						

【Appendix 1】 Introduction to Renewal Tool

(d) DIO command/serial communication 400 V class

Model (Note 3)	Replacement model example (Note 4)	Connector compatibility		Mounting compatibility	Conversion cable	Mounting attachment
		Power supply	Command			
MR-J3-60T4	MR-J4-60A4-RJ	(Note 5)	(Note 6)	○	(Note 6)	
MR-J3-100T4	MR-J4-100A4-RJ	(Note 5)	(Note 6)	○		
MR-J3-200T4	MR-J4-200A4-RJ	(Note 5)	(Note 6)	○		
MR-J3-350T4	MR-J4-350A4-RJ	(Note 5)	(Note 6)	(Note 2)		
MR-J3-500T4	MR-J4-500A4-RJ	○	(Note 6)	○		SC-J2SJ4BS06
MR-J3-700T4	MR-J4-700A4-RJ	○	(Note 6)	○		
MR-J3-11KT4	MR-J4-11KA4-RJ	○	(Note 6)	(Note 2)		
MR-J3-15KT4	MR-J4-15KA4-RJ	○	(Note 6)	(Note 2)		
MR-J3-22KT4	MR-J4-22KA4-RJ	○	(Note 6)	○		

(e) DIO command/serial communication 100 V class

Model (Note 3)	Replacement model example (Note 4)	Connector compatibility		Mounting compatibility	Conversion cable	Mounting attachment
		Power supply	Command			
MR-J3-10T1	MR-J4-10A1-RJ	(Note 5)	(Note 6)	○	(Note 6)	
MR-J3-20T1	MR-J4-20A1-RJ	(Note 5)	(Note 6)	○		
MR-J3-40T1	MR-J4-40A1-RJ	(Note 5)	(Note 6)	○		

(2) MR-J3W series to MR-J4 series replacement models and renewal tools

(a) SSCNET interface 200 V class

Model	Replacement model example	Connector compatibility		Mounting compatibility	Conversion cable	Mounting attachment
		Power supply	Command			
MR-J3W-22B	MR-J4W2-22B	○	(Note 7)	(Note 8)	SC-J3WJ4WCTC03M	
MR-J3W-44B	MR-J4W2-44B	○	(Note 7)	(Note 8)		
MR-J3W-77B	MR-J4W2-77B	○	(Note 7)	(Note 2)		SC-J3WJ4WBS02
MR-J3W-1010B	MR-J4W2-1010B	○	(Note 7)	(Note 2)		

- Note
1. The position of the power supply terminal block is different. Extend the wire length if it is insufficient.
 2. By using the mounting attachment, it can be mounted using the existing mounting holes.
 3. When using the DIO command, the MR-J3-D01 extension I/O unit is connected.
 4. When using the DIO command, the MR-J3-D01 extension I/O unit can be used for MR-J4.
 5. For servo amplifiers of 3.5 kW or less, it is necessary to change the power connectors CNP1, CNP2, and CNP3 to the MR-J4 servo amplifier accessories.
 6. Since the connectors are different, a conversion cable is required if using an existing cable.
Contact Mitsubishi Electric System & Service Co., Ltd. for the specifications of the conversion cable.
 7. The control signal connectors are the same, but a conversion cable is still required because the pin arrangement is different.
 8. The dimensions are the same, but the number of mounting screws is different.

【Appendix 1】 Introduction to Renewal Tool

3.2 Servo Motor Substitute Model and Compatibility

POINT
<ul style="list-style-type: none"> ● Check the website of Mitsubishi Electric System & Service Co., Ltd. for the latest details and models. ● The meaning of the following two symbols used in the table is as follows. (B): With a brake (4): 400 V specification ● For servo motor models not listed in the table, refer to "Part 9: 1.1 Servo Motor Replacement Model and Compatibility". ● When replacing a servo motor, some replacement models do not have compatible connectors and there are some combinations in which a new cable installation is required. ● When replacing a servo motor, there are some combinations by which the capacity of the servo amplifier changes. Refer to Notes 1, 2, 3, and 5. ● Refer to Appendix 1-7 for notes.

(1) Medium capacity/ultra-low inertia, with gear reducer for high precision applications, flange mounting

Model	Replacement model example	Servo amplifier capacity compatibility	Servo motor side conversion cable								
			Power cable	Electromagnetic brake cable	Encoder cable	Cooling fan cable					
HC-RP103(B)G5 1/5	HG-SR102(B)G5 1/5	(Note 1)	SC-SAJ3PW2KC1M-S2	A new brake cable layout is required.	The existing cable can be used.	/					
HC-RP103(B)G5 1/11	HG-SR102(B)G5 1/11										
HC-RP103(B)G5 1/21	HG-SR102(B)G5 1/21										
HC-RP103(B)G5 1/33	HG-SR102(B)G5 1/33										
HC-RP103(B)G5 1/45	HG-SR102(B)G5 1/45										
HC-RP153(B)G5 1/5	HG-SR152(B)G5 1/5	○	SC-SAJ3PW2KC1M-S2	A new brake cable layout is required.	The existing cable can be used.	/					
HC-RP153(B)G5 1/11	HG-SR152(B)G5 1/11										
HC-RP153(B)G5 1/21	HG-SR152(B)G5 1/21										
HC-RP153(B)G5 1/33	HG-SR152(B)G5 1/33										
HC-RP153(B)G5 1/45	HG-SR152(B)G5 1/45										
HC-RP203(B)G5 1/5	HG-SR202(B)G5 1/5	(Note 2)	SC-J2SJ4PW2C1M	A new brake cable layout is required.	The existing cable can be used.	/					
HC-RP203(B)G5 1/11	HG-SR202(B)G5 1/11										
HC-RP203(B)G5 1/21	HG-SR202(B)G5 1/21										
HC-RP203(B)G5 1/33	HG-SR202(B)G5 1/33										
HC-RP203(B)G5 1/45	HG-SR202(B)G5 1/45										
HC-RP353(B)G5 1/5	HG-SR352(B)G5 1/5	(Note 1)	SC-HAJ3PW1C1M	A new brake cable layout is required.	The existing cable can be used.	/					
HC-RP353(B)G5 1/11	HG-SR352(B)G5 1/11										
HC-RP353(B)G5 1/21	HG-SR352(B)G5 1/21										
HC-RP353(B)G5 1/33	HG-SR352(B)G5 1/21										
HC-RP353(B)G5 1/45	HG-SR352(B)G5 1/21										
HC-RP503(B)G5 1/5	HG-SR502(B)G5 1/5	(Note 3)	SC-HAJ3PW1C1M	A new brake cable layout is required.	The existing cable can be used.	/					
HC-RP503(B)G5 1/11	HG-SR502(B)G5 1/11										
HC-RP503(B)G5 1/21	HG-SR502(B)G5 1/11										
HC-RP103(B)G7 1/5	HG-SR102(B)G7 1/5						(Note 1)	SC-SAJ3PW2KC1M-S2	A new brake cable layout is required.	The existing cable can be used.	/
HC-RP103(B)G7 1/11	HG-SR102(B)G7 1/11										
HC-RP103(B)G7 1/21	HG-SR102(B)G7 1/21										
HC-RP103(B)G7 1/33	HG-SR102(B)G7 1/33										
HC-RP103(B)G7 1/45	HG-SR102(B)G7 1/45										
HC-RP153(B)G7 1/5	HG-SR152(B)G7 1/5	○	SC-SAJ3PW2KC1M-S2	A new brake cable layout is required.	The existing cable can be used.	/					
HC-RP153(B)G7 1/11	HG-SR152(B)G7 1/11										
HC-RP153(B)G7 1/21	HG-SR152(B)G7 1/21										
HC-RP153(B)G7 1/33	HG-SR152(B)G7 1/33										
HC-RP153(B)G7 1/45	HG-SR152(B)G7 1/45										
HC-RP203(B)G7 1/5	HG-SR202(B)G7 1/5	(Note 2)	SC-J2SJ4PW2C1M	A new brake cable layout is required.	The existing cable can be used.	/					
HC-RP203(B)G7 1/11	HG-SR202(B)G7 1/11										
HC-RP203(B)G7 1/21	HG-SR202(B)G7 1/21										
HC-RP203(B)G7 1/33	HG-SR202(B)G7 1/33										
HC-RP203(B)G7 1/45	HG-SR202(B)G7 1/45										
HC-RP353(B)G7 1/5	HG-SR352(B)G7 1/5	(Note 1)	SC-HAJ3PW1C1M	A new brake cable layout is required.	The existing cable can be used.	/					
HC-RP353(B)G7 1/11	HG-SR352(B)G7 1/11										
HC-RP353(B)G7 1/21	HG-SR352(B)G7 1/21										
HC-RP353(B)G7 1/33	HG-SR352(B)G7 1/21										
HC-RP353(B)G7 1/45	HG-SR352(B)G7 1/21										
HC-RP503(B)G7 1/5	HG-SR502(B)G7 1/5	(Note 3)	SC-HAJ3PW1C1M	A new brake cable layout is required.	The existing cable can be used.	/					
HC-RP503(B)G7 1/11	HG-SR502(B)G7 1/11										
HC-RP503(B)G7 1/21	HG-SR502(B)G7 1/11										

【Appendix 1】 Introduction to Renewal Tool

(3) Medium capacity/low inertia HC-LP series

Model	Replacement model example	Servo amplifier capacity compatibility	Servo motor side conversion cable			
			Power cable	Electromagnetic brake cable	Encoder cable	Cooling fan cable
HC-LP52(B)	HG-JR73(B)	(Note 1)	SC-SAJ3PW2KC1M-S2	A new brake cable layout is required.	The existing cable can be used.	/
HC-LP102(B)	HG-JR153(B)					
HC-LP152(B)	HG-JR353(B)	(Note 2)	(Note 4)			
HC-LP202(B)	HG-JR353(B)	○	SC-HAJ3PW1C1M			
HC-LP302(B)	HG-JR503(B)	(Note 3)				

(4) Medium/large capacity/low inertia HA-LP series

Model	Replacement model example	Servo amplifier capacity compatibility	Servo motor side conversion cable				
			Power cable	Electromagnetic brake cable	Encoder cable	Cooling fan cable	
HA-LP601(4)(B)	HG-JR601(4)(B)	○	SC-SAJ3PW7KC1M-A	The existing cable can be used.	SC-J3J4ENM1C1M or SC-J3J4ENM1C1M-A	(Note 6)	
HA-LP801(4)(B)	HG-JR801(4)(B)		SC-J2SJ4PW3C1M-A_				
HA-LP12K1(4)(B)	HG-JR12K1(4)(B)		The existing cable can be used. (Note 7)	/	A new encoder cable layout is required.	SC-J2SJ4FAN1C1M	
HA-LP15K1(4)	HG-JR15K1(4)						
HA-LP20K1(4)	HG-JR20K1(4)						
HA-LP25K1(4)	HG-JR25K1(4)						
HA-LP30K1(4)	HG-JR30K1(4)		The existing cable can be used.	SC-SAJ3PW7KC1M-A	The existing cable can be used.	SC-J3J4ENM1C1M or SC-J3J4ENM1C1M-A	(Note 6)
HA-LP37K1(4)	HG-JR37K1(4)						
HA-LP601(4)(B)	HG-JR601(4)(R)(B)-S		○	SC-SAJ3PW7KC1M-A	The existing cable can be used.	SC-J3J4ENM1C1M or SC-J3J4ENM1C1M-A	(Note 6)
HA-LP801(4)(B)	HG-JR801(4)(R)(B)-S			SC-J2SJ4PW3C1M-A_			
HA-LP12K1(4)(B)	HG-JR12K1(4)(R)(B)-S			The existing cable can be used. (Note 7)	/	A new encoder cable layout is required.	SC-J2SJ4FAN1C1M
HA-LP15K1(4)	HG-JR15K1(4)(R)-S						
HA-LP20K1(4)	HG-JR20K1(4)(R)-S_						
HA-LP25K1(4)	HG-JR25K1(4)(R)-S						
HA-LP30K1(4)	HG-JR30K1(4)(R)-S	The existing cable can be used.		SC-SAJ3PW7KC1M-A_	The existing cable can be used.	SC-J3J4ENM1C1M or SC-J3J4ENM1C1M-A_	(Note 6)
HA-LP37K1(4)	HG-JR37K1(4)(R)-S						
HA-LP701M(4)(B)	HG-JR701M(4)(B)	○		SC-SAJ3PW7KC1M-A	The existing cable can be used.	SC-J3J4ENM1C1M or SC-J3J4ENM1C1M-A_	(Note 6)
HA-LP11K1M(4)(B)	HG-JR11K1M(4)(B)			SC-J2SJ4PW3C1M-A			
HA-LP15K1M(B)	HG-JR15K1M(B)			The existing cable can be used. (Note 7)	/	A new encoder cable layout is required.	SC-J2SJ4FAN1C1M
HA-LP15K1M4(B)	HG-JR15K1M4(B)						
HA-LP22K1M(4)	HG-JR22K1M(4)						
HA-LP30K1M(4)	HG-JR30K1M(4)						
HA-LP37K1M(4)	HG-JR37K1M(4)		The existing cable can be used.	SC-SAJ3PW7KC1M-A_	The existing cable can be used.	SC-J3J4ENM1C1M or SC-J3J4ENM1C1M-A_	(Note 6)
HA-LP45K1M4	HG-JR45K1M4						
HA-LP50K1M4	HG-JR55K1M4		The existing cable can be used. (Note 7)	SC-J2SJ4PW3C1M-A	The existing cable can be used.	SC-J3J4PW1C1M-A	(Note 6)
HA-LP701M(4)(B)	HG-JR701M(4)(R)(B)-S_ (□250)						
HA-LP11K1M(4)(B)	HG-JR11K1M(4)(R)(B)-S_ (□250)		○	SC-J3J4PW1C1M-A	The existing cable can be used.	SC-J3J4ENM1C1M or SC-J3J4ENM1C1M-A_	(Note 6)
HA-LP15K1M(B)	HG-JR15K1MR(B)-S			SC-J2SJ4PW3C1M-A			
HA-LP15K1M4(B)	HG-JR15K1M4R(B)-S			The existing cable can be used. (Note 7)	/	A new encoder cable layout is required.	SC-J2SJ4FAN1C1M
HA-LP22K1M(4)	HG-JR22K1M(4)(R)-S_						
HA-LP30K1M(4)	HG-JR30K1M(4)(R)-S						
HA-LP37K1M(4)	HG-JR37K1M(4)(R)-S						
HA-LP45K1M4	HG-JR45K1M4R-S	The existing cable can be used.		SC-J2SJ4PW3C1M-A	The existing cable can be used.	SC-J3J4PW1C1M-A	(Note 6)
HA-LP50K1M4	HG-JR55K1M4R-S						
HA-LP502	HG-SR502	○		SC-HAJ3PW1C1M	The existing cable can be used.	The existing cable can be used.	(Note 6)
HA-LP702	HG-SR702			The existing cable can be used.			
HA-LP11K2(4)(B)	HG-JR11K1M(4)(B)			The existing cable can be used.	/	A new encoder cable layout is required.	SC-J2SJ4FAN1C1M
HA-LP15K2(4)(B)	HG-JR11K1M(4)(B)						
HA-LP22K2(B)	HG-JR15K1M(B)						
HA-LP22K24(B)	HG-JR15K1M4(B)						
HA-LP30K2(4)	HG-JR22K1M(4)		(Note 5)	The existing cable can be used.	The existing cable can be used.	SC-J3J4ENM1C1M or SC-J3J4ENM1C1M-A_	
HA-LP37K2(4)	HG-JR30K1M(4)						
HA-LP45K24	HG-JR37K1M4						
HA-LP55K24	HG-JR45K1M4						

【Appendix 1】 Introduction to Renewal Tool

Model	Replacement model example	Servo amplifier capacity compatibility	Servo motor side conversion cable			
			Power cable	Electromagnetic brake cable	Encoder cable	Cooling fan cable
HA-LP502	HG-SR502R-S	○	SC-HAJ3PW1C1M		The existing cable can be used.	
HA-LP702	HG-SR702R-S_		The existing cable can be used.			
HA-LP11K2(4)(B)	HG-JR11K1M(4)R(B)-S_(□200)	(Note 5)	SC-J2SJ4PW3C1M-A_	The existing cable can be used.	SC-J3J4ENM1C1M or SC-J3J4ENM1C1M-A_	(Note 6)
HA-LP15K2(B)	HG-JR11K1MR(B)-S_(□250)					
HA-LP15K24(B)	HG-JR11K1M4R(B)-S_(□250)					
HA-LP22K2(B)	HG-JR15K1MR(B)-S					
HA-LP22K24(B)	HG-JR15K1M4R(B)-S					
HA-LP30K2(4)	HG-JR22K1M(4)R-S_	(Note 5)	The existing cable can be used.		A new encoder cable layout is required.	SC-J2SJ4FAN1C1M
HA-LP37K2(4)	HG-JR30K1M(4)R-S		The existing cable can be used.		A new encoder cable layout is required.	SC-J2SJ4FAN1C1M
HA-LP45K24	HG-JR37K1M4R-S					
HA-LP55K24	HG-JR45K1M4R-S					

- Note
1. The capacity of the servo amplifier has changed, and the mounting holes of the servo amplifier are not compatible.
 2. The capacity of the servo amplifier will change, but the mounting holes of the servo amplifier are compatible.
 3. The position of the power supply terminal block of the servo amplifier is different. Extend the wire length if it is insufficient.
 4. The wire thickness of the servo motor power cable is different, so a new servo motor power cable is required.
 5. When replacing the servo motor (secondary replacement) after replacing only the servo amplifier (primary replacement), the capacity of the servo amplifier will change and the servo amplifier is to be replaced again. Simultaneous replacement (batch replacement) of the servo amplifier and servo motor is recommended.
 6. The existing cooling fan cable is not used. Remove or insulate the cable.
 7. The terminal size of the servo motor power supply (U, V, W) cable needs to be changed from M8 to M10.

【Appendix 1】 Introduction to Renewal Tool

4. RENEWAL TOOL PRODUCT LIST

(1) Mounting attachment

No.	Model	Application	Replacement method
1	SC-J2SJ4BS04	MR-J4- _A_ servo amplifier capacity: 5 kW (200 V), 3.5 kW (400 V)	Used for primary Replacement and Simultaneous replacement
2	SC-J2SJ4BS06	MR-J4- _A_ servo amplifier capacity: 11 kW, 15 kW	
3	SC-J3WJ4WBS02	MR-J4W2-77B/MR-J4W2-1010B	

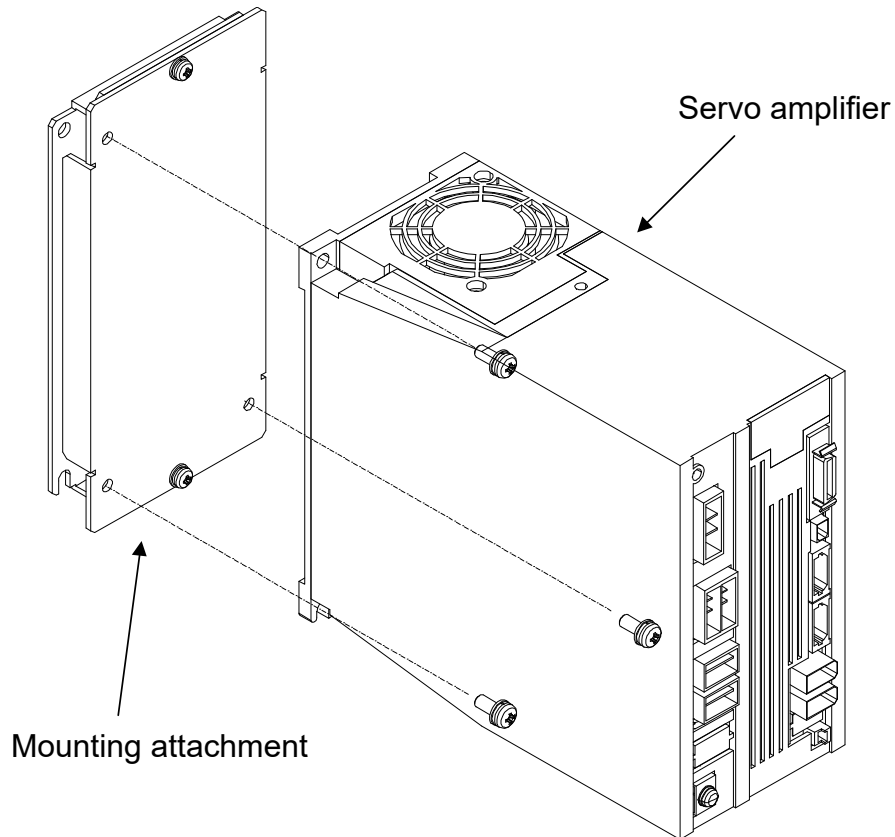

(example SC-J3WJ4WBS02)

【Appendix 1】 Introduction to Renewal Tool

(2) Servo motor side conversion cable (For compatibility of servo motor connectors)

No.	Product name	Model	Replacement servo motor model	Replacement method	
1	Encoder conversion cable (Note)	(Straight connector) SC-J3J4ENM1C1M	For the target servo motor, check the replacement combination table in section 3.2 (4) "Medium/large capacity/low inertia HA-LP series" in this appendix.	Used at the time of secondary replacement and batch replacement	
2		(Angle connector) SC-J3J4ENM1C1M-A_			
3	Power supply conversion cable	SC-J2SJ4PW2C1M	HC-RP203(B)G5/G7 → HG-SR202(B)G5/G7		
4		SC-SAJ3PW2KC1M-S2	HC-LP52(B) → HG-JR73(B)		
5		SC-HAJ3PW1C1M	HC-LP202(B)		HG-JR353(B)
			HC-LP302(B) HA-LP502		→ HG-JR503(B) HG-SR502
6		SC-J2SJ4PW3C1M-A_	HA-LP601(4)(B)		HG-JR601(4)(B)
			HA-LP701M(4)(B)		HG-JR701M(4)(B)
			HA-LP11K2(4)(B)		HG-JR11K1M(4)(B)
			HA-LP801(4)(B)	→ HG-JR801(4)(B)	
	HA-LP12K1(4)(B)		HG-JR12K1(4)(B)		
	HA-LP11K1M(4)(B)		HG-JR11K1M(4)(B)		
7	SC-J3J4PW1C1M-A_	HA-LP15K1M(B)	→ HG-JR15K1M(B)		
		HA-LP22K2(B)			
8	SC-SAJ3PW7K1M-A_	HA-LP601(4)(B) HA-LP701M(4)(B)	→ HG-JR601(4)(B) → HG-JR701M(4)(B)		
9	Cooling fan conversion cable	SC-J2SJ4FAN1C1M	For the target servo motor, check the replacement combination table in section 3.2 (4) "Medium/large capacity/low inertia HA-LP series" in this appendix.		

Note. Both the two-wire type and four-wire type are supported.

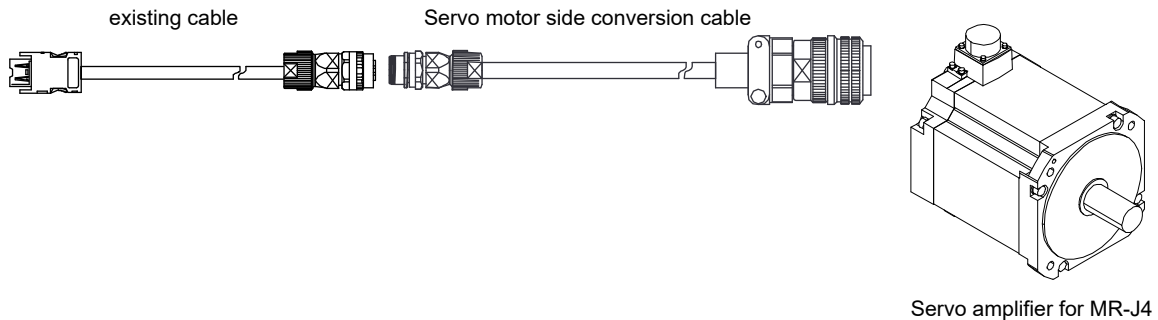

(example SC-J3J4ENM1C1M)

【Appendix 1】 Introduction to Renewal Tool

(3) Servo amplifier side conversion cable

No.	Name	Model	Application	Replacement method
1	Servo amplifier side conversion cable	SC-J3WJ4WCTC03M	For changing MR-J4W2-_B input/output signals	Used for primary replacement and simultaneous replacement.

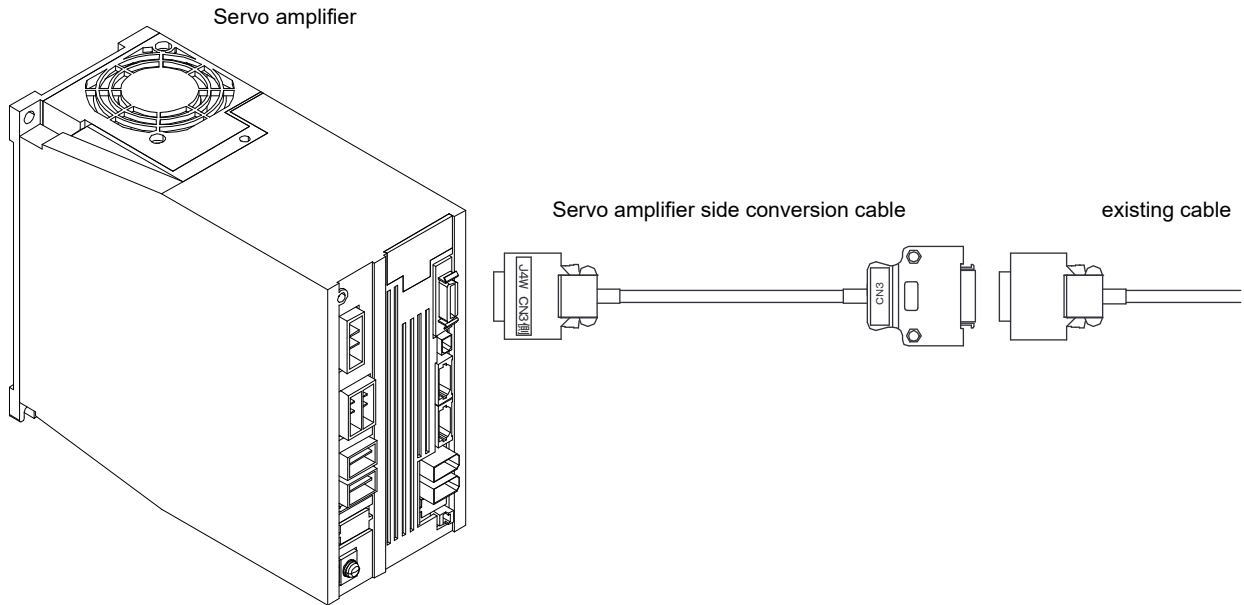

【Appendix 1】 Introduction to Renewal Tool

5. SPECIFICATIONS

5.1 Standard Specifications

(1) Mounting attachment specifications

Item		Specifications
Environment	Usage ambient temperature	0°C to +55°C (non-freezing).
	Storage ambient temperature	-20°C to +65°C (non-freezing).
	Usage ambient humidity	90 %RH or less (non-condensing).
	Storage ambient humidity	
	Ambience	Indoors (no direct sunlight), free from corrosive gas, flammable gas, oil mist, dust, and dirt
	Altitude	Max. 2000 m
	Vibration resistance	5.9 m/s ² at 10 Hz to 55 Hz (directions of X, Y, and Z axes)
Material	SPCC (Cold rolled steel plate)	
Surface treatment	Trivalent chromate	
Mass	About 750 g	

(2) Conversion cable specifications (For both servo amplifier side and servo motor side)

Item		Specifications
Environment	Usage ambient temperature	0°C to +55°C (non-freezing).
	Storage ambient temperature	-20°C to +65°C (non-freezing).
	Usage ambient humidity	90 %RH or less (non-condensing).
	Storage ambient humidity	
	Ambience	Indoors (no direct sunlight), free from corrosive gas, flammable gas, oil mist, dust, and dirt
	Altitude	Max. 2000 m
	Vibration resistance	5.9 m/s ² at 10 Hz to 55 Hz (directions of X, Y, and Z axes)
Minimum bend radius	6 times or more of the cable outer diameter	

【Appendix 1】 Introduction to Renewal Tool

6. DIMENSIONS

6.1 Mounting attachment

The dimensions are the same for all models listed in section 3.1 of this appendix.

(1) SC-J2SJ4BS04

(a) Mounting attachment alone

Unit [mm]

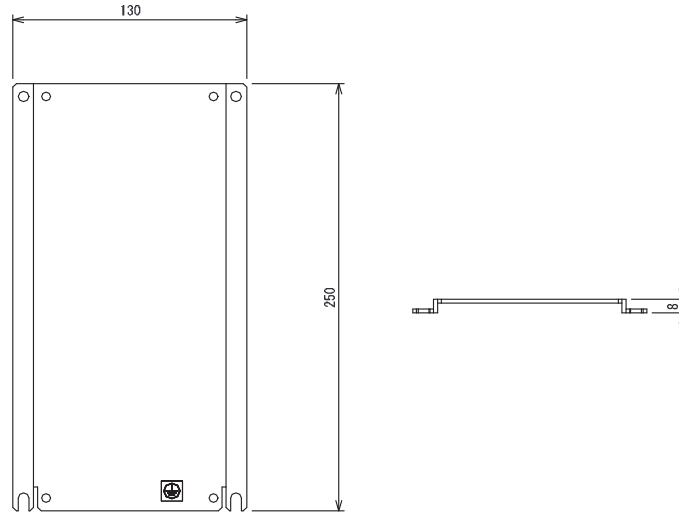

(b) Mounting attachment + Combination with servo amplifier

Unit [mm]

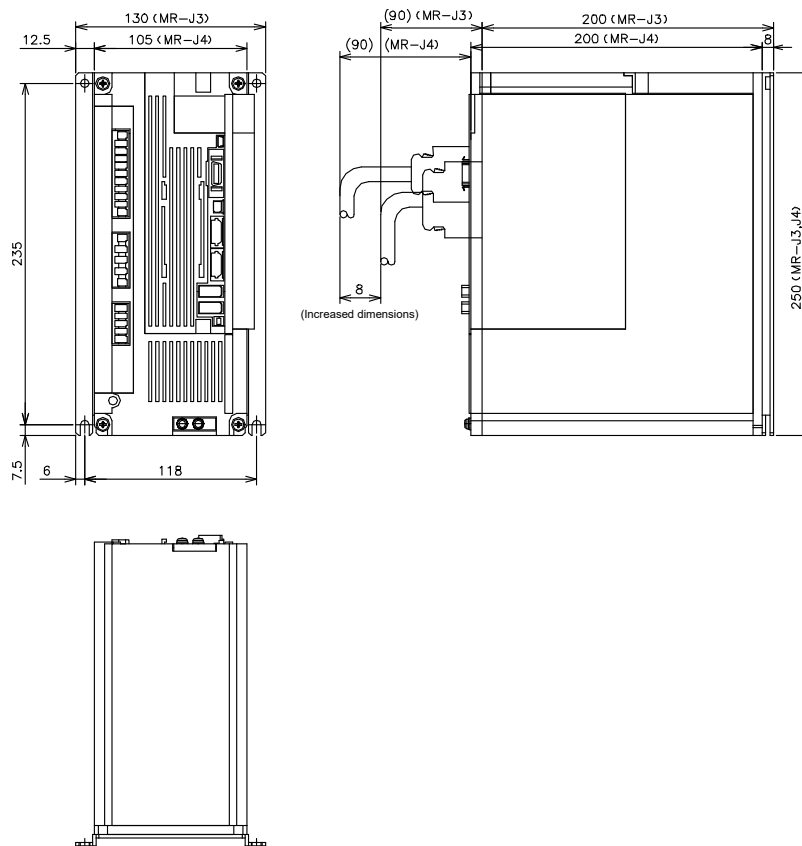

【Appendix 1】 Introduction to Renewal Tool

(2) SC-J2SJ4BS06

(a) Mounting attachment alone

Unit [mm]

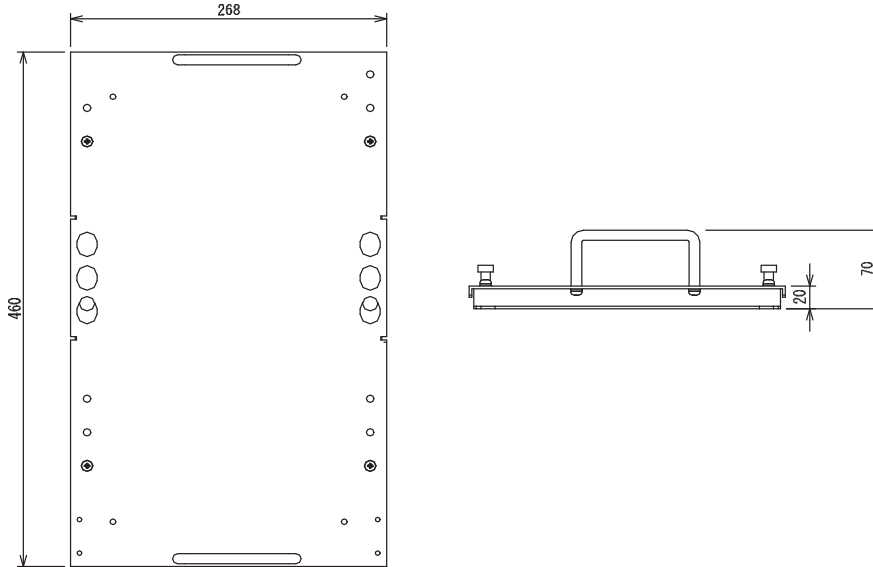

(b) Mounting attachment + Combination with servo amplifier

Unit [mm]

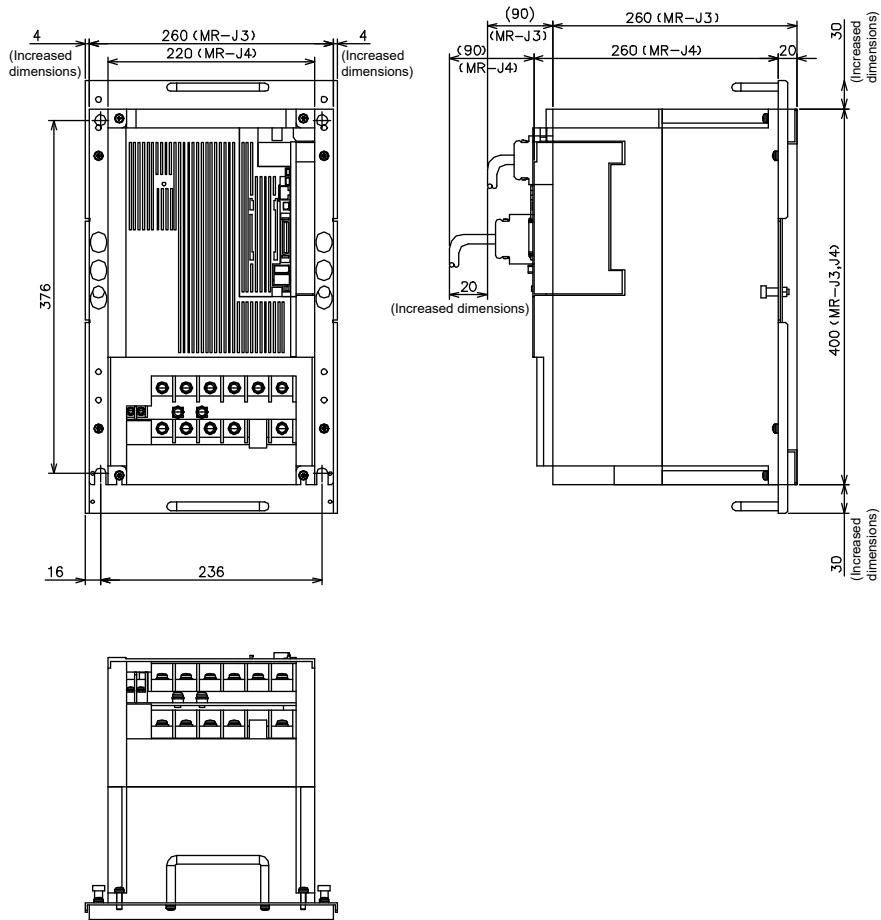

Note. The mounting attachment cannot be used for mounting panel through attachments of MR-J3 servo amplifier.

【Appendix 1】 Introduction to Renewal Tool

(3) SC-J3WJ4WBS02

(a) Mounting attachment alone

Unit [mm]

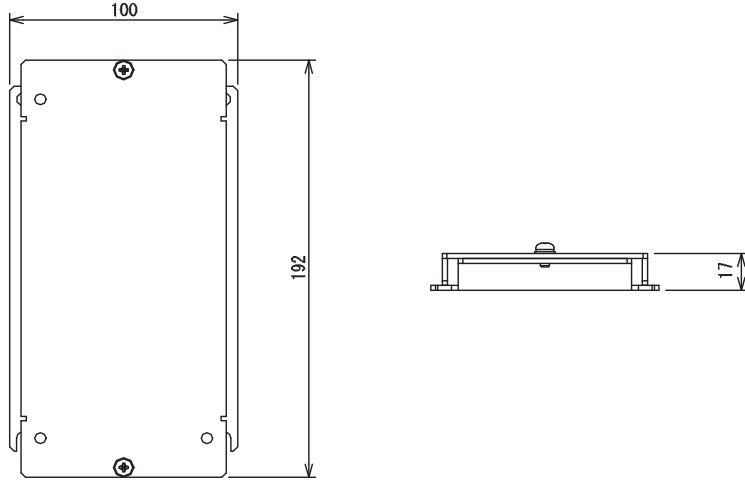

(b) Mounting attachment + Combination with servo amplifier

Unit [mm]

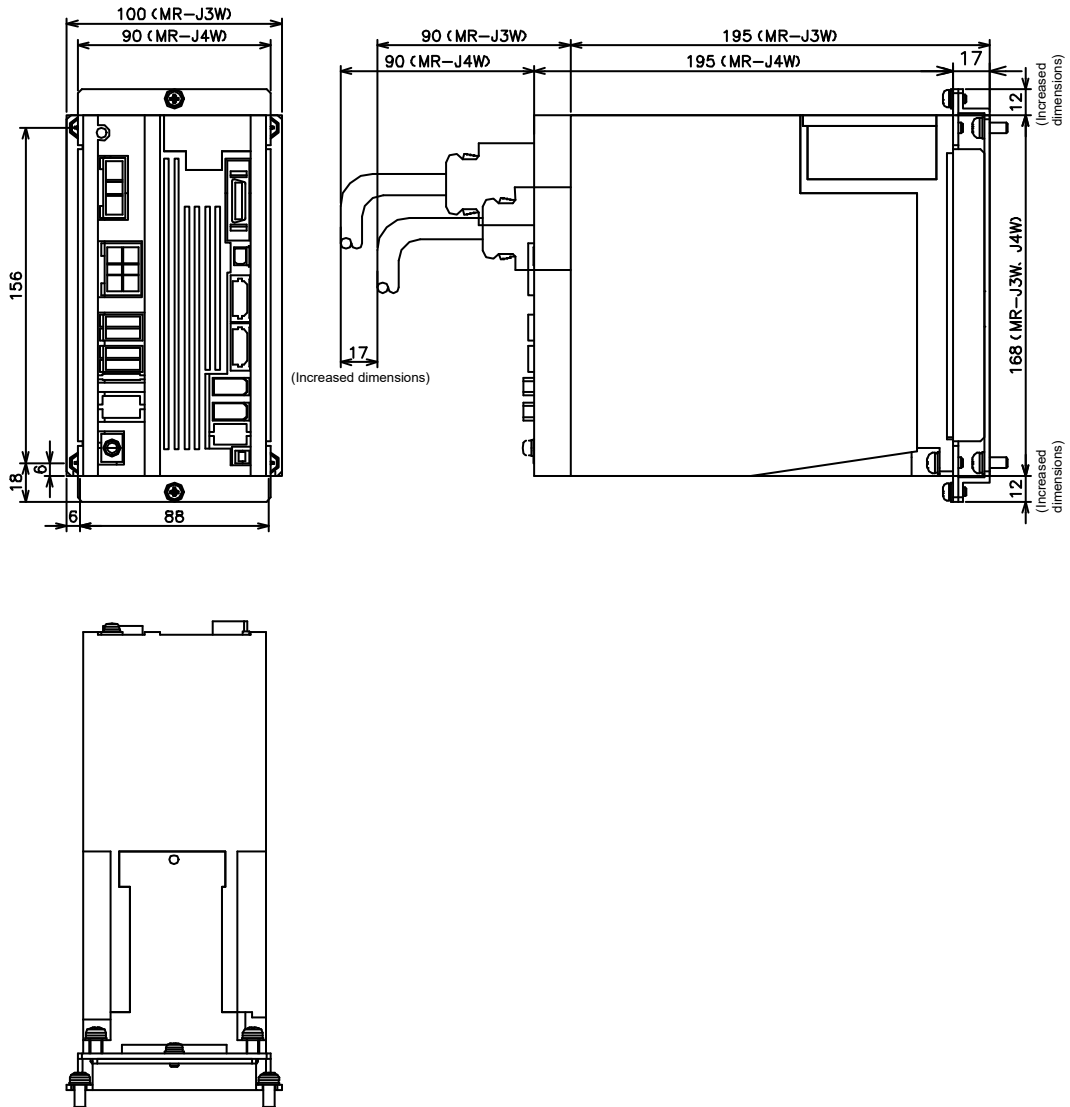

【Appendix 1】 Introduction to Renewal Tool

6.2 Conversion cable

6.2.1 Servo motor side power supply conversion cable

(1) SC-J3J4PW1C1M-

— Cable pulling direction: A1, A2 (Note)

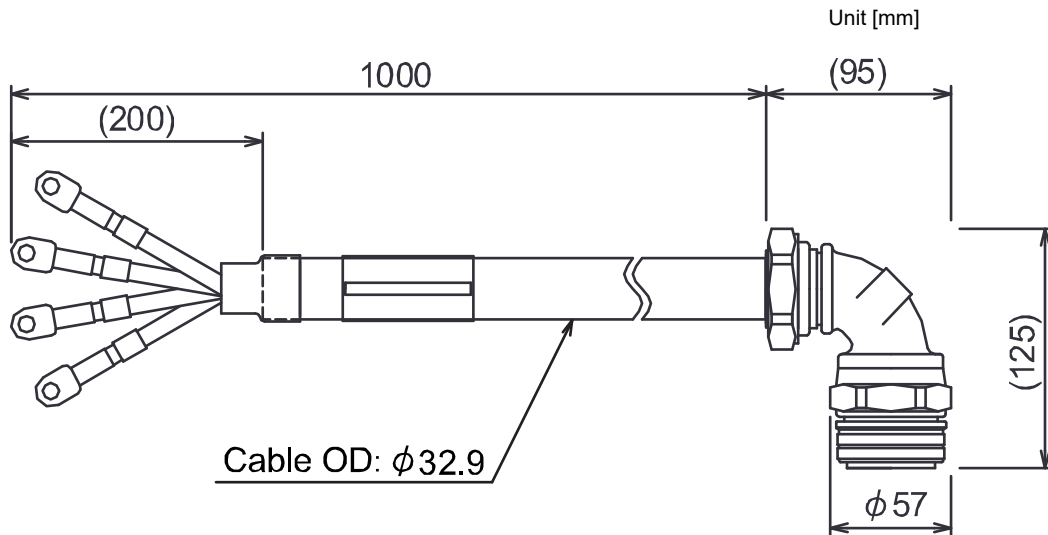

Note. For the cable pulling directions, refer to section 6.2.3.

(2) SC-SAJ3PW2KC1M-S2/SC-HAJ3PW1C1M/SC-J2SJ4PW2C1M

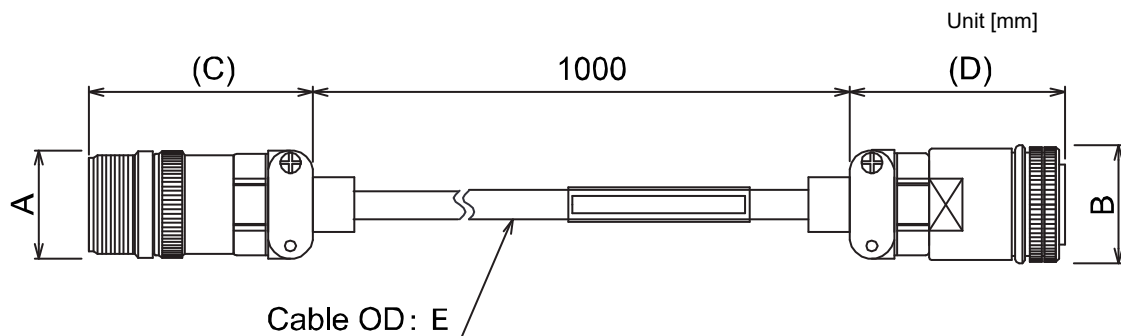

Item	Specifications		
Model	SC-SAJ3PW2KC1M-S2	SC-HAJ3PW1C1M	SC-J2SJ4PW2C1M
Connector dimensions	A	$\phi 35$	$\phi 39$
	B	$\phi 35$	$\phi 41$
	C	68	74
	D	78	77
Cable shape	E	$\phi 12.0$	$\phi 14$

【Appendix 1】 Introduction to Renewal Tool

(3) SC-J2SJ4PW3C1M-
 Cable pulling direction: A1, A2 (Note)

SC-J2SJ4PW3C1M-
 Cable pulling direction: A1, A2 (Note)

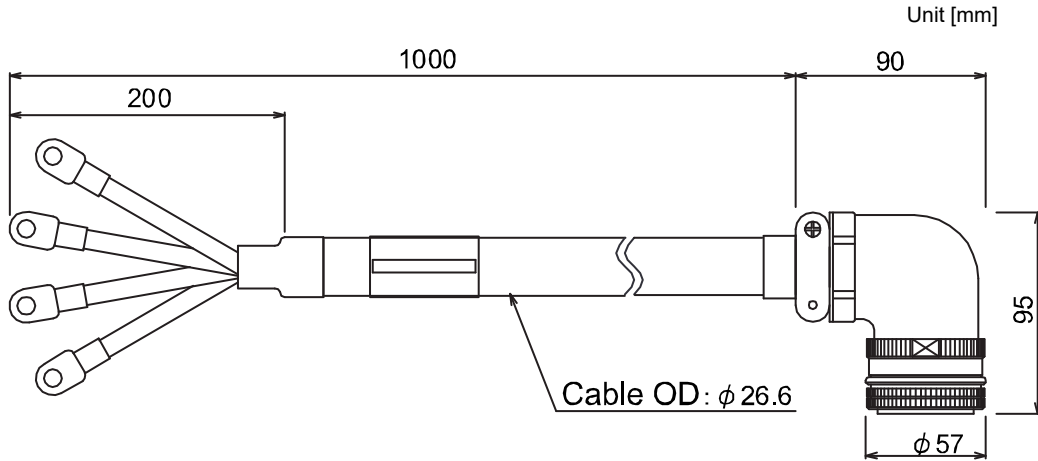

Note. For the cable pulling directions, refer to section 6.2.3.

Item		Specifications	
Model		SC-J2SJ4PW3C1M- <u> </u>	SC-SAJ3PW7KC1M- <u> </u>
Cable shape	A	φ 25.6	φ 21.3
crimp terminal	B	R14-8	R8-6

【Appendix 1】 Introduction to Renewal Tool

6.2.2 Servo motor side encoder conversion cable

(1) SC-J3J4ENM1C1M

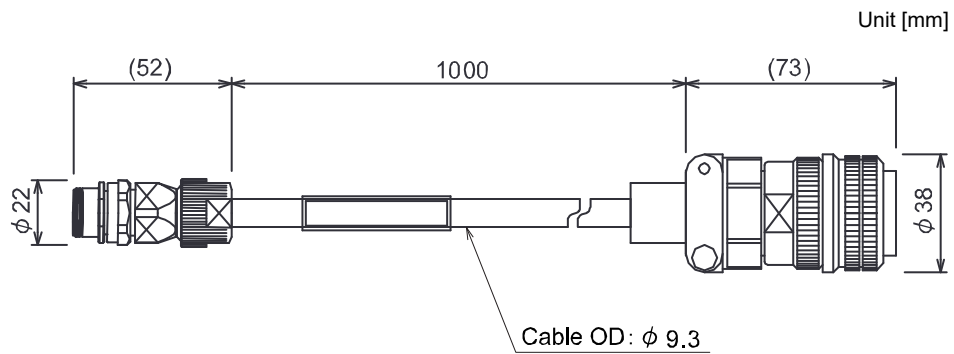

(2) SC-J3J4ENM1C1M-

Cable pulling direction: A2, A3, A4 (Note)

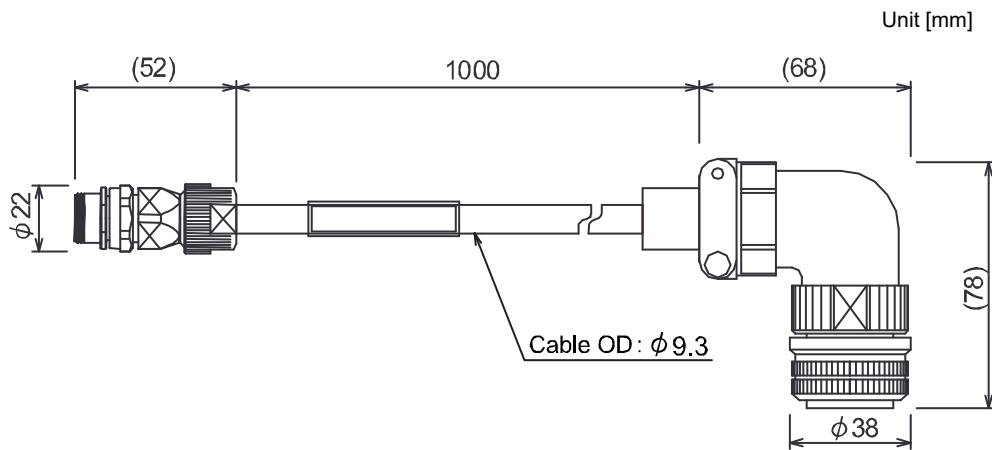

Note. For the cable pulling directions, refer to section 6.2.3.

【Appendix 1】 Introduction to Renewal Tool

6.2.3 Cable pulling direction

(1) Pulling direction of the servo motor side power supply conversion cable

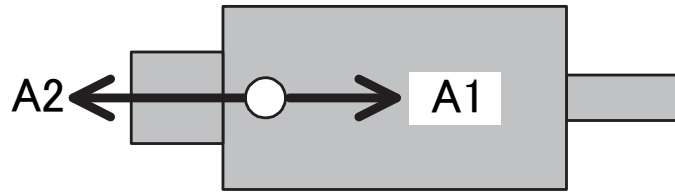

Cable pulling direction
(Diagram viewed from the front of the cable insertion hole)

(2) Pulling direction of the servo motor side encoder conversion cable

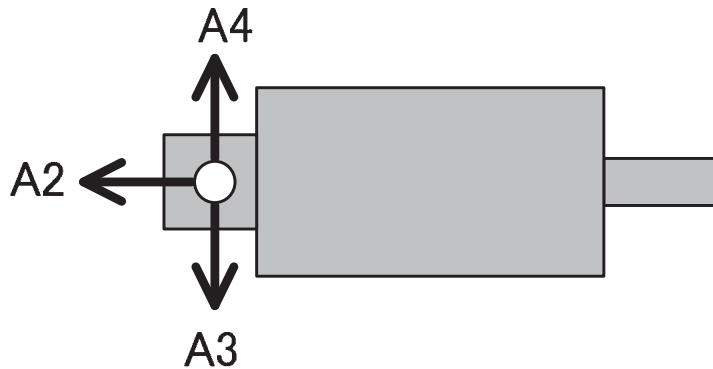

Cable pulling direction
(Diagram viewed from the front of the cable insertion hole)

6.2.4 Servo motor side conversion cable for the cooling fan

(1) SC-J2SJ4FAN1C1M

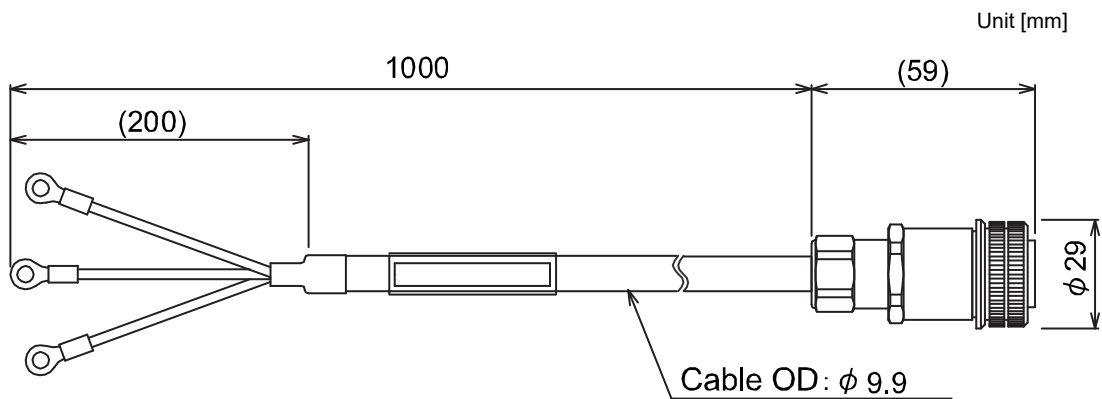

【Appendix 1】 Introduction to Renewal Tool

6.2.5 The control signal conversion cable for the servo amplifier side

POINT
● The following shows the names of the cable connection diagram signals. Servo amplifier side: MR-J4W2_B pin assignment Existing control signal cable side: MR-J3W-_B pin assignment After checking the cable connection diagrams and "Part 4: Replacement of MR-J3W-_B with MR-J4W2-_B", use the product according to your specification.

(1) SC-J3WJ4WCTC03M

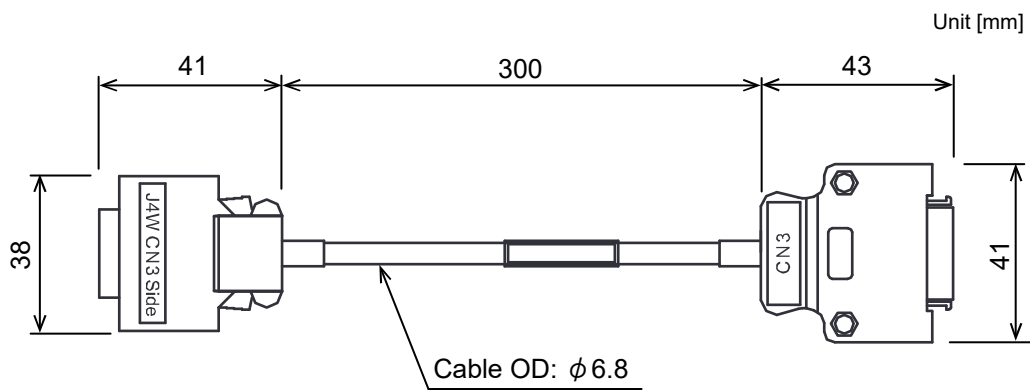

【Appendix 1】 Introduction to Renewal Tool

Connection diagrams

Servo amplifier side
(J4W CN3 side)

Existing control signal cable side
(CN3 side)

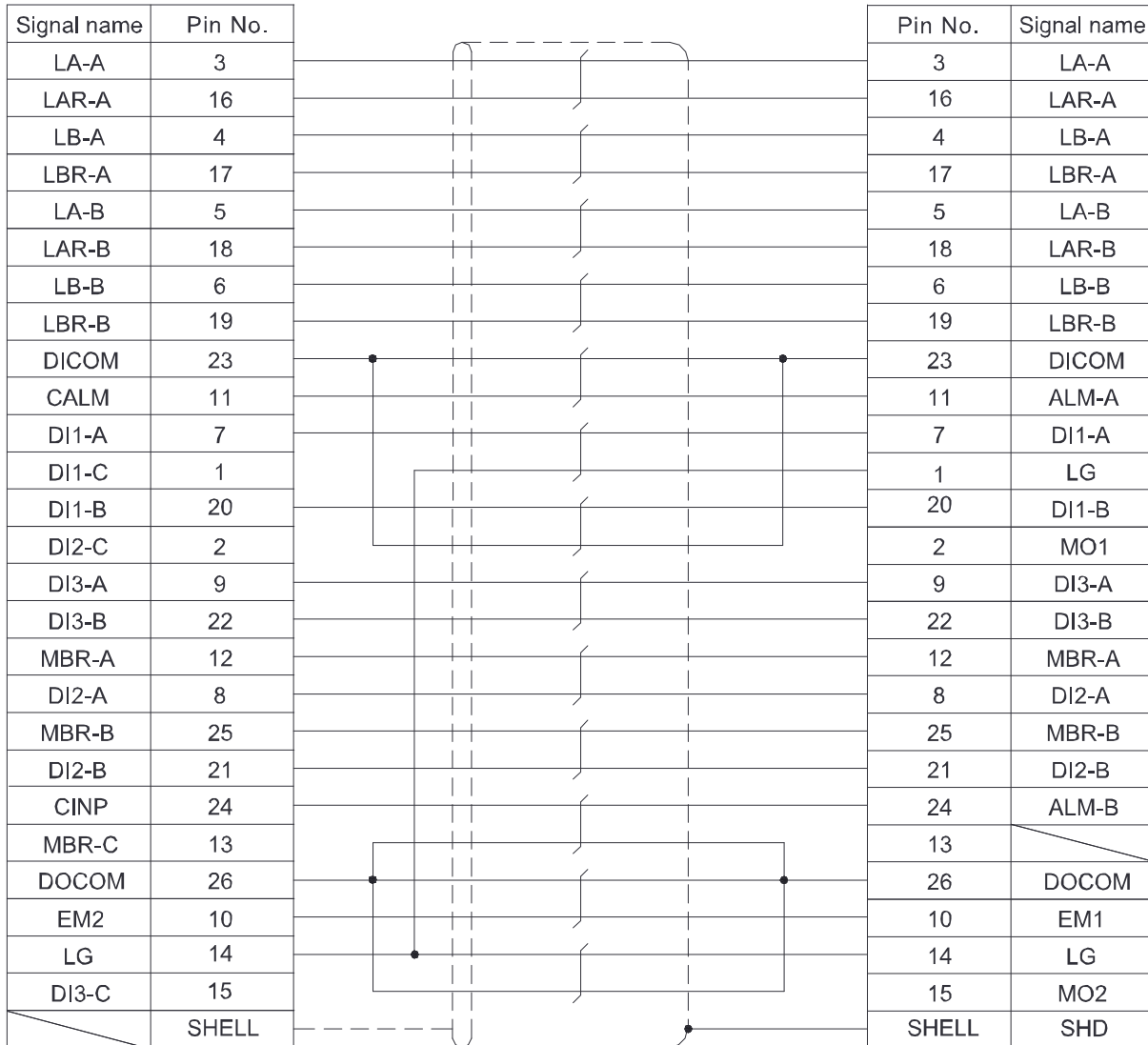

Note. After checking the cable connection diagrams, use the product according to your specification.

REVISIONS

*The installation guide number is given on the bottom left of the back cover.

Print date	*Installation guide number	Revision description
Nov. 2016	L(NA)03127ENG-A	First edition
Aug. 2017	L(NA)03127ENG-B	<p>MR-J3W series is added.</p> <p>Safety Instructions Partially changed.</p> <p>Part 1 MR-J3W series/MR-J4W2-_B servo amplifier are added.</p> <p>Part 1 Chapter 1 Partially changed.</p> <p>Part 1 Section 2.1 The table is partially changed.</p> <p>Part 1 Section 3.1.1 The diagram is partially changed.</p> <p>Part 1 Section 3.1.4 The table is added.</p> <p>Part 1 Section 3.2.1 The table is partially changed.</p> <p>Part 1 Section 3.2.2 (2) The table is added.</p> <p>Part 1 Section 3.2.2 (3) The table is partially changed.</p> <p>Part 1 Section 3.2.4 Partially changed.</p> <p>Part 1 Section 4.2 Partially changed.</p> <p>Part 1 Section 4.3 Partially changed.</p> <p>Part 2 Section 2.2 (2) The diagram is partially changed.</p> <p>Part 2 Section 3.5.3 The table is partially changed.</p> <p>Part 3 Section 2.1 The diagram is partially changed.</p> <p>Part 3 Section 2.2 The diagram is partially changed.</p> <p>Part 3 Section 3.2 POINT is added.</p> <p>Part 3 Section 3.6.3 The table is partially changed.</p> <p>Part 3 Chapter 4 POINT is added.</p> <p>Part 4 Newly added.</p> <p>Part 5 MR-J3W series/MR-J4W2-_B servo amplifier is added.</p> <p>Part 5 Section 1.1 (1) The table is partially changed.</p> <p>Part 5 Section 1.2.2 The table is partially changed.</p> <p>Part 5 Section 1.2.3 (1) Table (b) is newly added.</p> <p>Part 5 Section 1.2.3 (3) The table is partially changed.</p> <p>Part 5 Section 1.2.4 (1) The table is partially changed.</p> <p>Part 5 Section 1.2.6 Partially changed.</p> <p>Part 5 Section 1.2.7 The table is partially changed.</p> <p>Part 5 Section 1.3 Newly added.</p> <p>Part 5 Section 2.3 Partially changed.</p> <p>Part 5 Section 2.3.4 (2) Newly added.</p> <p>Part 5 Chapter 5 Newly added.</p> <p>Part 5 Chapter 6 Moved from Part 2.</p> <p>Part 5 Section 6.1.2 The table is partially changed.</p> <p>Part 5 Section 6.1.3 The table is partially changed.</p> <p>Part 5 Section 6.1.9 The table is partially changed.</p> <p>Part 7 MR-J3W series/MR-J4W2-_B servo amplifier is added.</p> <p>Part 7 Chapter 1 The table is partially changed.</p> <p>Part 7 Section 1.1.1 The table is partially changed.</p> <p>Part 7 Section 1.1.2 The table is partially changed.</p> <p>Part 7 Chapter 3 The table is partially changed.</p> <p>Part 7 Section 4.1.3 Newly added.</p> <p>Part 7 Section 4.1.4 Newly added.</p> <p>Part 7 Section 4.3.3 Newly added.</p> <p>Part 7 Section 4.3.4 Newly added.</p> <p>Part 7 Section 5.1 Newly added.</p>

Print date	*Installation guide number	Revision description	
Aug. 2017	L(NA)03127ENG-B	Part 7 Section 5.4	Newly added.
		Part 7 Section 5.5	Newly added.
		Part 7 Section 6.1	The table is partially changed.
		Part 7 Chapter 7	Partially changed.
		Part 7 Section 8.3.1	The table is partially changed.
		Part 8 Section 1.1	The diagram is partially changed.
May 2018	L(NA)03127ENG-C	MR-J3-DU_/MR-J4-DU_ servo amplifier	are added.
		MR-J3W-0303BN6/MR-J4W2-0303B6 servo amplifier	are added.
		Introduction to Renewal Tool	are added.
		Part 1 Section 3.1.3	POINT is added.
		Part 1 Section 3.1.4	The table is partially changed.
		Part 1 Section 3.2.1	The table is partially changed.
		Part 1 Section 3.2.2 (1)	The table (c) (d) (g) (h) newly added.
		Part 1 Section 3.2.2 (2)	The table (b) is newly added.
		Part 1 Section 3.2.2 (3)	Table (a) (b) are partially changed.
		Part 1 Section 3.2.2 (3)	Table (c) is newly added.
		Part 1 Section 3.2.4	Partially changed.
		Part 1 Section 4.2	Partially changed.
		Part 2 Section 3.1	POINT is added.
		Part 2 Section 3.1	The table is partially changed.
		Part 2 Section 3.6	POINT is added.
		Part 3 Section 3.1	POINT is added.
		Part 3 Section 3.1	The table is partially changed.
		Part 4	MR-J3W-0303BN6/MR-J4W2-0303B6 servo amplifier are newly added.
		Part 4 Section 2.2	The table is partially changed.
		Part 4 Section 3.1 (1)	The table is partially changed.
		Part 4 Section 3.1 (2)	Newly added.
		Part 4 Section 3.2 (3)	Newly added.
		Part 4 Section 3.2 (4)	Newly added.
		Part 4 Section 3.5.2	Newly added.
		Part 4 Section 3.7.1	The table is partially changed.
		Part 4 Section 3.7.2	The table is partially changed.
		Part 4 Section 3.7.3	The table is partially changed.
		Part 5	MR-J3-DU_/MR-J4-DU_ servo amplifier servo amplifier are newly added.
		Part 6	Part number is changed from 5
		Part 6 Section 1.1	POINT is added.
		Part 6 Section 1.2.1	The table is partially changed.
		Part 6 Section 1.2.3	The table is partially changed.
		Part 6 Section 1.2.6 (3)	Newly added.
		Part 6 Section 1.2.6 (4)	Newly added.
		Part 6 Section 1.2.6 (5)	Newly added.
		Part 6 Section 1.3	Newly added.
		Part 6 Section 2.1	POINT is added.
		Part 6 Section 2.1.3	Newly added.
		Part 6 Section 2.1.4	Newly added.
		Part 6 Section 5.1	The table is partially added.
		Part 6 Section 5.2	Newly added.

Print date	*Installation guide number	Revision description	
May 2019	L(NA)03127ENG-D	Part 2 Section 3.1 (1)(2) Part 2 Section 3.1 (3) Part 2 Section 3.3 Part 2 Section 3.5.1 Part 2 Section 3.5.2 Part 2 Section 3.5.3 Part 2 Section 3.6 Part 3 Section 2.1 Part 3 Section 2.2 Part 3 Section 3.1 (1)(2) Part 3 Section 3.1 (3) Part 3 Section 3.4 Part 3 Section 3.6.2 Part 3 Section 3.6.3 Part 4 Section 2.1 Part 4 Section 2.3 Part 4 Section 3.1 Part 4 Section 3.2 (2) Part 4 Section 3.3 Part 4 Section 3.5.1 (2) Part 4 Section 3.5.2 (2) Part 4 Section 3.7 Part 4 Section 3.7.3 Part 4 Chapter 4 Part 5 Section 2.2 Part 5 Section 2.3 (2) Part 5 Section 4.1.1 Part 5 Section 4.1.2 Part 5 Section 4.2 (3)(c) Part 5 Section 4.3 (2)(3) Part 5 Chapter 5 Part 5 Section 5.1.2 Part 5 Section 5.2.1 Part 5 Section 6.1 Part 5 Section 6.2 Part 5 Section 6.1 Part 5 Section 7.1 Part 5 Section 7.1.1 Part 5 Section 7.2 Part 5 Section 7.1.1 Part 5 Section 7.2.2 Part 5 Section 7.3 Part 5 Section 7.4.3 Part 5 Section 7.7 Part 6 Part 7 Part 7 Section 1.1 Part 7 Section 1.2.1 Part 7 Section 1.2.2	The table is partially changed. 100 V class are added. The table is partially changed. The table is partially changed. The table is partially changed. The table is partially changed. The table is partially changed. The table is partially changed. Partially changed. Partially changed. 100 V class are added. Partially changed. Partially changed. The table is partially changed. Partially changed. Partially changed. Partially changed. The table is partially changed. The table is partially changed. Partially changed. The table is partially changed. Partially changed. Partially changed. The diagram is partially changed. The diagram is partially changed. The diagram is partially changed. Partially changed. The table is partially changed. Partially changed. Partially changed. Partially changed. The table is partially added. Partially changed. Partially changed. Partially changed. The diagram is partially changed. Partially changed. Partially changed. Deleted. MR-J3-_T_(DIO command/Serial communication operation) with MR-J4-_A_-RJ_ servo amplifier are added. Part number is changed from 6 Partially added. Partially changed. Partially changed.

Print date	*Installation guide number	Revision description	
May 2019	L(NA)03127ENG-D	Part 7 Section 1.2.3 Part 7 Section 1.2.6 (1)(2) Part 7 Section 1.2.6 (6)(7) Part 7 Section 1.3 Part 7 Section 2.1 Part 7 Section 2.1.1 Part 7 Section 2.1.2 Part 7 Section 2.1.3 Part 7 Section 2.2.1 Part 7 Section 2.2.2 Part 7 Section 2.2.3 Part 7 Section 2.2.4 Part 7 Section 2.2.4 (4) Part 7 Section 2.2.5 Part 7 Section 2.2.5 Part 7 Section 2.2.6 Part 7 Section 2.2.7 Part 7 Section 2.2.8 Part 7 Section 2.3.2 Part 7 Section 2.3.2 (4) Part 7 Section 2.3.3 Part 7 Section 2.3.3 Part 7 Section 2.3.4 Part 7 Chapter 4 Part 7 Section 4.4.1 Part 7 Section 4.5.4 Part 7 Section 4.5.5 Part 7 Section 4.5.7 Part 7 Section 5.1 Part 7 Section 5.1 (1)(2) Part 7 Section 5.2 Part 7 Section 5.2 (1) Part 7 Section 6.1.9 Part 8 Section Part 8 Section 1.1 Part 8 Section 1.1 Part 8 Section 2.6 Part 8 Section 2.7 (3)(9) Part 9 Section Part 9 Chapter 1 Part 9 Section 1.1.2 Part 9 Section 1.1.3 Part 9 Section 1.2.2 Part 9 Chapter 2 Part 9 Section 3.1 Part 9 Section 4.3.2 Part 9 Section 5.3.1 Part 9 Section 6.1 Part 9 Section 7.1 Part 9 Section 7.2	Partially changed. Partially changed. Newly added. Partially added. POINT is added. The table is partially added. The table is partially added. Newly added. Partially added. Partially added. Partially added. Partially added. The diagram is partially changed. POINT is added. The table is partially changed. The table is partially added. Newly added. Newly added. POINT is added. Partially added. POINT is partially added. The table is partially added. The table is partially changed. POINT is partially added. The table is partially changed. The table is partially changed. The table is partially changed. The table is partially changed. POINT is partially added. The table is partially changed. POINT is partially added. The table is partially changed. Partially changed. Part number is changed from 7 POINT is partially added. The table is partially added. The table is partially changed. The table is partially changed. The table is partially changed. POINT is partially added. The table is partially added. The table is partially changed. The table is partially added. The table is partially changed. The table is partially changed. The table is partially changed. POINT is partially changed. The table is partially added. The table is partially changed. The table is partially changed.

Print date	*Installation guide number	Revision description
May 2019	L(NA)03127ENG-D	Part 9 Section 7.3 The table is partially added. Part 9 Section 7.4 The table is partially added. Part 9 Section 7.5 The table is partially added. Part 9 Section 7.6 The table is partially added. Part 10 Section Part number is changed from 9
Oct. 2021	L(NA)03127ENG-E	MR-J3-_T_(CC-Link communication operation) with MR-J4-_GF_ servo amplifier are added. SAFETY INSTRUCTIONS Partially changed. Part 1 Section 2.1 The table is partially changed. Part 1 Section 2.2 Partially changed. Part 1 Section 3.1.1 The table is partially changed. Part 1 Section 3.1.3 POINT is partially changed. Part 1 Section 3.1.3 The table is partially changed. Part 1 Section 3.1.4 POINT is partially changed. Part 1 Section 3.1.4 The table is partially changed. Part 1 Section 3.2.1 The table is partially changed. Part 1 Section 3.2.1 (1) The table is partially changed. Part 1 Section 3.2.1 (1) The table (d) (i) (q) added. Part 1 Section 3.2.1 (2) The table is partially changed. Part 1 Section 3.2.1 (3) The table is partially changed. Part 1 Section 3.2.3 (3) Partially changed. Part 1 Section 3.2.4 Partially changed. Partially add. Part 1 Section 3.2.5 Partially changed. Part 1 Section 3.2.6 Partially changed. Part 1 Section 4.6 Partially changed. Partially add. Part 1 Section 4.4 Partially changed. Part 2 Section 2.2 The diagram is partially changed. Part 2 Section 2.2 (1) Partially changed. Part 2 Section 2.2 (2) POINT is partially changed. Part 2 Section 3.1 (1) The table is partially changed. Part 2 Section 3.3 (2) The table is partially changed. Part 2 Section 3.4 POINT is partially changed. Part 2 Section 3.5 POINT is partially changed. Part 2 Section 3.5.1 The table is partially changed. Part 2 Section 3.5.2 The table is partially changed. Part 2 Section 3.5.3 The table is partially changed. Part 2 Section 3.6.2 (2) Partially changed. Part 2 Section 3.6 (2) Partially changed. Part 3 Section 2.1 Partially changed. Part 3 Section 2.2 Partially changed. Part 3 Section 3.1 Partially changed. Part 3 Section 3.2 POINT is partially changed. Part 3 Section 3.4 Partially changed. Part 3 Section 3.5 POINT is partially changed. Part 3 Section 3.6 POINT is partially changed. Part 3 Section 3.6.1 The table is partially changed. Part 3 Section 3.6.3 The table is partially changed. Part 4 Section 2.1 The diagram is partially changed. Part 4 Section 2.2 Partially changed.

Print date	*Installation guide number	Revision description	
Oct. 2021	L(NA)03127ENG-E	Part 8 Section 1.1	Partially changed.
		Part 8 Section 1.2.2	Partially changed.
		Part 8 Section 1.2.3	Partially changed.
		Part 8 Section 1.2.4	Partially changed.
		Part 8 Section 1.2.4	POINT is partially changed.
		Part 8 Section 1.2.5	Partially changed.
		Part 8 Section 1.2.6	Partially changed.
		Part 8 Section 1.2.7	The diagram is partially changed.
		Part 8 Section 1.3	Partially changed.
		Part 8 Section 2.1	POINT is partially changed.
		Part 8 Section 2.1.1	Partially changed.
		Part 8 Section 2.1.2	Partially changed.
		Part 8 Section 2.1.5	Partially changed.
		Part 8 Section 2.2.1	POINT is partially changed.
		Part 8 Section 2.2.1	Partially changed.
		Part 8 Section 2.2.2	POINT is partially changed.
		Part 8 Section 2.2.2	The diagram is partially changed.
		Part 8 Section 2.2.3	Partially deleted.
		Part 8 Section 2.2.4	Partially changed.
		Part 8 Section 2.2.5	POINT is partially changed.
		Part 8 Section 2.2.6	The table is partially changed.
		Part 8 Section 2.2.7	POINT is partially added and changed.
		Part 8 Section 2.2.7	The table is partially changed.
		Part 8 Section 2.2.8	The table is partially changed.
		Part 8 Section 2.2.9	Newly added.
		Part 8 Section 2.2.10	Newly added.
		Part 8 Section 2.3	POINT is partially changed.
		Part 8 Section 2.3.1	The diagram is partially changed.
		Part 8 Section 2.3.2	POINT is partially changed.
		Part 8 Section 2.3.4	The table is partially changed.
		Part 8 Chapter 4	POINT is partially changed.
		Part 8 Section 4.4.1	The table is partially changed.
		Part 8 Section 5.1	POINT is partially changed.
		Part 8 Section 5.1	The table is partially added and changed.
		Part 8 Section 5.2	POINT is partially changed.
		Part 8 Section 6.1.1	Partially changed.
		Part 8 Section 6.1.7	Partially added.
		Part 8 Section 6.1.8	Partially added.
		Part 8 Section 6.1.9	Partially changed.
		Part 8 Section 6.3	POINT is partially changed.
		Part 8 Section 6.3.2	Partially changed.
		Part 9	Part number is changed from 8
		Part 9 Section 1.1	POINT is partially changed.
		Part 9 Section 1.1	The table is partially changed.
		Part 9 Section 2.1	POINT is partially changed.
		Part 9 Section 2.1	The table is partially changed.
		Part 9 Section 2.2	POINT is partially changed.
		Part 9 Section 2.2	The table is partially changed.

Print date	*Installation guide number	Revision description	
Oct. 2021	L(NA)03127ENG-E	Part 9 Section 2.3 Part 9 Section 2.4 Part 9 Section 2.5 Part 9 Section 2.5 Part 9 Section 2.7 Part 10 Part 10 Chapter 1 Part 10 Section 1.1.1 Part 10 Section 1.1.2 Part 10 Section 3.1 Part 10 Section 4.1.1 Part 10 Section 4.1.2 Part 10 Section 4.1.2 Part 10 Section 4.1.3 Part 10 Section 4.1.4 Part 10 Section 4.1.4 Part 10 Section 4.3.1 Part 10 Section 4.3.2 Part 10 Section 4.3.3 Part 10 Section 4.3.4 Part 10 Section 5.1 Part 10 Section 5.2 Part 10 Section 5.3.1 Part 10 Section 5.3.1 Part 10 Section 5.3.1 Part 10 Section 5.3.2 Part 10 Section 5.4.1 Part 10 Section 5.5 Part 10 Section 7.5 Part 10 Section 7.6 Part 10 Section 7.6 Part 10 Section 8.3.1 Part 11 Part 10 Chapter 1 Part 11 Section 1.1 Appendix 1	POINT is partially changed. POINT is partially changed. POINT is partially changed. The table is partially changed. Partially changed. Part number is changed from 9 POINT is partially changed. Partially changed. Partially changed. The table is partially added. POINT is partially changed. POINT is partially changed. The table is partially changed. Partially changed. POINT is partially changed. Partially changed. Partially changed. Partially changed. Partially changed. Partially changed. Partially changed. Partially added. POINT is partially added and changed. The diagram is partially added and changed. Partially added and changed. Partially changed. POINT is partially changed. The table is partially changed. The diagram is partially changed. The table is partially changed. The table is partially changed. Part number is changed from 10 CAUTION is partially changed. Partially changed. Complete changed.

This installation guide guarantees no industrial rights or implementation of any rights of any other kind, nor does it grant any licenses. Mitsubishi Electric Corporation cannot be held responsible for any problems involving industrial rights which may occur as a result of using the contents noted in this installation guide.

Service Network

Global FA Centers

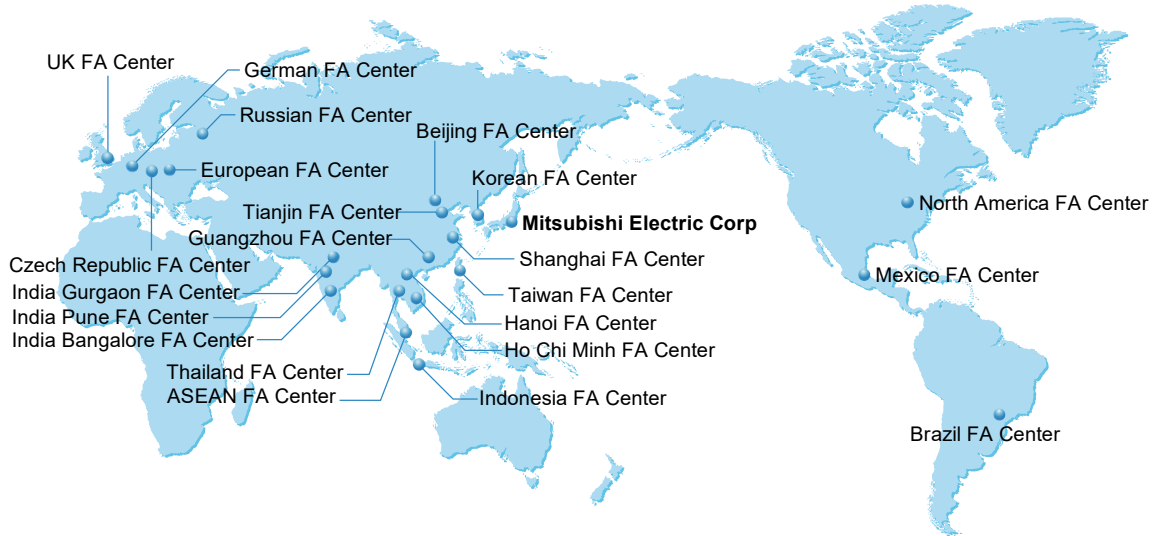

China

Shanghai FA Center
MITSUBISHI ELECTRIC AUTOMATION (CHINA) LTD.
 10F, Mitsubishi Electric Automation Center, No.1386 Hongqiao Road, Changning District, Shanghai, China
 Tel: 86-21-2322-3030 Fax: 86-21-2322-3000 (9611#)

Beijing FA Center
MITSUBISHI ELECTRIC AUTOMATION (CHINA) LTD. Beijing Office
 Unit 908, Office Tower 1, Henderson Centre, 18 Jianguomennei Avenue, Dongcheng District, Beijing, China
 Tel: 86-10-6518-8830 Fax: 86-10-6518-3907

Tianjin FA Center
MITSUBISHI ELECTRIC AUTOMATION (CHINA) LTD. Tianjin Office
 Room 2003 City Tower, No.35, Youyi Road, Hexi District, Tianjin, China
 Tel: 86-22-2813-1015 Fax: 86-22-2813-1017

Guangzhou FA Center
MITSUBISHI ELECTRIC AUTOMATION (CHINA) LTD. Guangzhou Office
 Room 1609, North Tower, The Hub Center, No.1068, Xingang East Road, Haizhu District, Guangzhou, China
 Tel: 86-20-8923-6730 Fax: 86-20-8923-6715

Taiwan

Taiwan FA Center
SETSUYO ENTERPRISE CO., LTD.
 3F, No.105, Wugong 3rd Road, Wugu District, New Taipei City 24889, Taiwan, R.O.C.
 Tel: 886-2-2299-9917 Fax: 886-2-2299-9963

Korea

Korean FA Center
MITSUBISHI ELECTRIC AUTOMATION KOREA CO., LTD.
 B1F, 2F, 1480-6, Gayang-Dong, Gangseo-Gu, Seoul, 157-200, Korea
 Tel: 82-2-3660-9630 Fax: 82-2-3663-0475

Thailand

Thailand FA Center
MITSUBISHI ELECTRIC FACTORY AUTOMATION (THAILAND) CO., LTD.
 12th Floor, SV.City Building, Office Tower 1, No. 896/19 and 20 Rama 3 Road, Kwaeng Bangpompang, Khet Yannawa, Bangkok 10120, Thailand
 Tel: 66-2682-6522 to 6531 Fax: 66-2682-6020

ASEAN

ASEAN FA Center
MITSUBISHI ELECTRIC ASIA PTE. LTD.
 307, Alexandra Road, Mitsubishi Electric Building, Singapore 159943
 Tel: 65-6470-2480 Fax: 65-6476-7439

Indonesia

Indonesia FA Center
PT. MITSUBISHI ELECTRIC INDONESIA
 Gedung Jaya 11th Floor, JL MH. Thamrin No.12, Jakarta, Pusat 10340, Indonesia
 Tel: 62-21-3192-6461 Fax: 62-21-3192-3942

Vietnam

Hanoi FA Center
MITSUBISHI ELECTRIC VIETNAM COMPANY LIMITED Hanoi Branch
 Unit 9-05, 9th Floor, Hanoi Central Office Building, 44B Ly Thuong Kiet Street, Hoan Kiem District, Hanoi City, Vietnam
 Tel: 84-4-3937-8075 Fax: 84-4-3937-8076

Ho Chi Minh FA Center
MITSUBISHI ELECTRIC VIETNAM COMPANY LIMITED
 Unit 01-04, 10th Floor, Vincom Center, 72 Le Thanh Ton Street, District 1, Ho Chi Minh City, Vietnam
 Tel: 84-8-3910-5945 Fax: 84-8-3910-5947

India

India Pune FA Center
MITSUBISHI ELECTRIC INDIA PVT. LTD. Pune Branch
 Emerald House, EL-3, J Block, M.I.D.C., Bhosari, Pune, 411026, Maharashtra State, India
 Tel: 91-20-2710-2000 Fax: 91-20-2710-2100

India Gurgaon FA Center
MITSUBISHI ELECTRIC INDIA PVT. LTD. Gurgaon Head Office
 2nd Floor, Tower A & B, Cyber Greens, DLF Cyber City, DLF Phase - III, Gurgaon - 122002 Haryana, India
 Tel: 91-124-463-0300 Fax: 91-124-463-0399

India Bangalore FA Center
MITSUBISHI ELECTRIC INDIA PVT. LTD. Bangalore Branch
 Prestige Emerald, 6th Floor, Municipal No.2, Madras Bank Road, Bangalore 560001, India
 Tel: 91-80-4020-1600 Fax: 91-80-4020-1699

America

North America FA Center
MITSUBISHI ELECTRIC AUTOMATION, INC.
 500 Corporate Woods Parkway, Vernon Hills, IL 60061, U.S.A.
 Tel: 1-847-478-2100 Fax: 1-847-478-2253

Mexico

Mexico FA Center
MITSUBISHI ELECTRIC AUTOMATION, INC. Mexico Branch
 Mariano Escobedo #69, Col.Zona Industrial, Tlalnepantla Edb, C.P.54030, México
 Tel: 52-55-3067-7511

Brazil

Brazil FA Center
MITSUBISHI ELECTRIC DO BRASIL COMÉRCIO E SERVIÇOS LTDA.
 Rua Jussara, 1750- Bloco B Anexo, Jardim Santa Cecilia, CEP 06465-070, Barueri - SP, Brasil
 Tel: 55-11-4689-3000 Fax: 55-11-4689-3016

Europe

European FA Center
MITSUBISHI ELECTRIC EUROPE B.V. Polish Branch
 32-083 Balice ul. Krakowska 50, Poland
 Tel: 48-12-630-47-00 Fax: 48-12-630-47-01

German FA Center
MITSUBISHI ELECTRIC EUROPE B.V. German Branch
 Gothaer Strasse 8, D-40880 Ratingen, Germany
 Tel: 49-2102-486-0 Fax: 49-2102-486-1120

UK FA Center
MITSUBISHI ELECTRIC EUROPE B.V. UK Branch
 Travellers Lane, Hatfield, Hertfordshire, AL10 8XB, U.K.
 Tel: 44-1707-28-8780 Fax: 44-1707-27-8695

Czech Republic FA Center
MITSUBISHI ELECTRIC EUROPE B.V. Czech Branch
 Avenir Business Park, Radicka 751/113e, 158 00 Praha5, Czech Republic
 Tel: 420-251-551-470 Fax: 420-251-551-471

Russian FA Center
MITSUBISHI ELECTRIC EUROPE B.V. Russian Branch St. Petersburg office
 Piskarevsky pr. 2, bld 2, lit "Sch", BC "Benua", office 720; 195027, St. Petersburg, Russia
 Tel: 7-812-633-3497 Fax: 7-812-633-3499

Transition from MELSERVO-J3/J3W Series to J4 Series Handbook

Country/Region Sales office

USA	Mitsubishi Electric Automation, Inc. 500 Corporate Woods Parkway, Vernon Hills, IL 60061, U.S.A.	Tel : +1-847-478-2100
Mexico	Mitsubishi Electric Automation, Inc. Mexico Branch Boulevard Miguel de Cervantes Saavedra 301, Torre Norte Piso 5, Ampliacion Granada, Miguel Hidalgo, Ciudad de Mexico, Mexico, C.P.11520	Tel : +52-55-3067-7512
Brazil	Mitsubishi Electric do Brasil Comercio e Servicos Ltda. Avenida Adelino Cardana, 293, 21 andar, Bethaville, Barueri SP, Brazil	Tel : +55-11-4689-3000
Germany	Mitsubishi Electric Europe B.V. German Branch Mitsubishi-Electric-Platz 1, 40882 Ratingen, Germany	Tel : +49-2102-486-0
UK	Mitsubishi Electric Europe B.V. UK Branch Travellers Lane, UK-Hatfield, Hertfordshire, AL10 8XB, U.K.	Tel : +44-1707-28-8780
Italy	Mitsubishi Electric Europe B.V. Italian Branch Centro Direzionale Colleoni - Palazzo Sirio, Viale Colleoni 7, 20864 Agrate Brianza (MB), Italy	Tel : +39-039-60531
Spain	Mitsubishi Electric Europe B.V. Spanish Branch Carretera de Rubi, 76-80-Apdo. 420, E-08174 Sant Cugat del Valles (Barcelona), Spain	Tel : +34-935-65-3131
France	Mitsubishi Electric Europe B.V. French Branch 25, Boulevard des Bouvets, 92741 Nanterre Cedex, France	Tel : +33-1-55-68-55-68
Czech Republic	Mitsubishi Electric Europe B.V. Czech Branch, Prague Office Pekarska 621/7, 155 00 Praha 5, Czech Republic	Tel : +420-255-719-200
Poland	Mitsubishi Electric Europe B.V. Polish Branch ul. Krakowska 48, 32-083 Balice, Poland	Tel : +48-12-347-65-00
Russia	Mitsubishi Electric (Russia) LLC St. Petersburg Branch Startovaya street, 8, BC "Aeroplaza", office 607; 196210, St. Petersburg, Russia	Tel : +7-812-449-51-34
Sweden	Mitsubishi Electric Europe B.V. (Scandinavia) Hedvig Mollersgata 6, 223 55 Lund, Sweden	Tel : +46-8-625-10-00
Turkey	Mitsubishi Electric Turkey A.S. Umraniye Branch Serifali Mah. Kale Sok. No:41 34775 Umraniye - Istanbul, Turkey	Tel : +90-216-969-2500
UAE	Mitsubishi Electric Europe B.V. Dubai Branch Dubai Silicon Oasis, P.O.BOX 341241, Dubai, U.A.E.	Tel : +971-4-3724716
South Africa	Adroit Technologies 20 Waterford Office Park, 189 Witkoppen Road, Fourways, South Africa	Tel : +27-11-658-8100
China	Mitsubishi Electric Automation (China) Ltd. Mitsubishi Electric Automation Center, No.1386 Hongqiao Road, Shanghai, China	Tel : +86-21-2322-3030
Taiwan	SETSUYO ENTERPRISE CO., LTD. 6F, No.105, Wugong 3rd Road, Wugu District, New Taipei City 24889, Taiwan	Tel : +886-2-2299-2499
Korea	Mitsubishi Electric Automation Korea Co., Ltd. 7F to 9F, Gangseo Hangang Xi-tower A, 401, Yangcheon-ro, Gangseo-Gu, Seoul 07528, Korea	Tel : +82-2-3660-9529
Singapore	Mitsubishi Electric Asia Pte. Ltd. 307 Alexandra Road, Mitsubishi Electric Building, Singapore 159943	Tel : +65-6473-2486
Thailand	Mitsubishi Electric Factory Automation (Thailand) Co., Ltd. True Digital Park Building Sukhumvit 101 Sukhumvit Road, Bang Chak, Prakanong, Bangkok, Thailand	Tel : +66-2092-8600
Indonesia	PT. Mitsubishi Electric Indonesia Gedung Jaya 8th Floor, JL. MH. Thamrin No.12, Jakarta Pusat 10340, Indonesia	Tel : +62-21-3192-6461
Vietnam	Mitsubishi Electric Vietnam Company Limited 11th & 12th Floor, Viettel Tower B, 285 Cach Mang Thang 8 Street, Ward 12, District 10, Ho Chi Minh City, Vietnam	Tel : +84-28-3910-5945
India	Mitsubishi Electric India Pvt. Ltd. Pune Branch Emerald House, EL-3, J Block, M.I.D.C., Bhosari, Pune - 411026, Maharashtra, India	Tel : +91-20-2710-2000
Australia	Mitsubishi Electric Australia Pty. Ltd. 348 Victoria Road, P.O. Box 11, Rydalmere, N.S.W 2116, Australia	Tel : +61-2-9684-7777

MITSUBISHI ELECTRIC CORPORATION

HEAD OFFICE: TOKYO BUILDING, 2-7-3, MARUNOUCHI, CHIYODA-KU, TOKYO 100-8310, JAPAN
NAGOYA WORKS: 1-14, YADA-MINAMI 5, HIGASHI-KU, NAGOYA, JAPAN