

## Programmable Controller

# CC-Link IE Field Network Waterproof/Dustproof Remote I/O Module (With Safety Functions) User's Manual

---

-NZ2GFS12A2-16DTE  
-NZ2GFS12A2-14DT

**Powered by**  
**molex**

This product was jointly developed and manufactured by Mitsubishi Electric and Molex.  
\*Note that the warranty on this product differs from that on other programmable controller products.  
(Refer to "WARRANTY" in this manual.)

'ORIGINAL INSTRUCTION'



# COPYRIGHT

---

This document is protected by the law of copyright, whereby all rights established therein remain with the company Mitsubishi Electric Corporation. Reproduction of this document or parts of this document is only permissible within the limits of the legal determination of Copyright Law. Alteration or abridgement of the document is not permitted without the explicit written approval of the company Mitsubishi Electric Corporation.

# PRECAUTIONS REGARDING WARRANTY

---

This product is jointly developed and manufactured with Molex. Thus, warranty information is different from that of other MELSEC products. Check the restrictions described below and purchase the product.

■ **Gratis Warranty Term**

Warranty period is one year after delivery. (Maximum of 18 months after produced)

■ **Repair and Analysis**

Please note that repairs and failure analysis are refused due to the structure of this product. Therefore, free replacement is arranged for the failure of our responsibility during the warranty period.

# SAFETY PRECAUTIONS

---

(Read these precautions before using this product.)

Before using this product, please read this manual and the relevant manuals carefully and pay full attention to safety to handle the product correctly.

The precautions given in this manual are concerned with this product only. For the safety precautions of the programmable controller system, refer to the user's manual for the CPU module used.

In this manual, the safety precautions are classified into two levels: "⚠️ WARNING" and "⚠️ CAUTION".

---

## **WARNING**

Indicates that incorrect handling may cause hazardous conditions, resulting in death or severe injury.

---

## **CAUTION**

Indicates that incorrect handling may cause hazardous conditions, resulting in minor or moderate injury or property damage.

---

Under some circumstances, failure to observe the precautions given under "⚠️ CAUTION" may lead to serious consequences.

Observe the precautions of both levels because they are important for personal and system safety.

Make sure that the end users read this manual and then keep the manual in a safe place for future reference.

## [Design Precautions]

---

### **WARNING**

---

- When the safety remote I/O module detects an error in an external power supply or a failure in the module, it turns off the outputs. Configure an external circuit to ensure that the power source of a hazard is shut off by turning off the outputs. Failure to do so may result in an accident due to an incorrect output or malfunction.
  - When a load current exceeding the rated current or an overcurrent caused by a load short-circuit flows, the safety remote I/O module defines it as a fault and turns off the outputs. Note that if the overcurrent state continues for a long time, it may cause smoke and fire. To prevent this, configure an external safety circuit, such as a fuse.
  - At the start-up of the system, if the load power supply is short-circuited by the output wiring of the safety remote I/O module, a load may turn on just after the power-on. Configure an interlock circuit to ensure that the entire system will always operate safely.
  - When a communication failure occurs in the network, data in the master module are held. Check Data link status (each station) (SW00B0 to SW00B7) and configure an interlock circuit in the program to ensure that the entire system will operate safely.
  - When a communication failure occurs in the network, the failed station becomes the following status. Check the communication status information and configure an interlock circuit in the program to ensure that the entire system will operate safely. Failure to do so may result in an accident due to an incorrect output or malfunction.
    - (1) All inputs from remote I/O stations are turned off.
    - (2) All outputs from remote I/O stations are turned off.
  - Do not use any "use prohibited" signals as a safety remote I/O signal and a remote control/monitor signal since they are used by the system. If any of the "use prohibited" signals are used (turned on or off), the correct operation of the module cannot be guaranteed.
  - Do not read/write data from/to the remote register since all areas of the remote register are "use prohibited" areas. If data is read or written from/to the remote register, correct operation of the module cannot be guaranteed.
-

## [Design Precautions]

---

### **CAUTION**

- Do not install the control lines or communication cables together with the main circuit lines or power cables. Keep a distance of 100mm or more between them. Failure to do so may result in malfunction due to noise.
  - Select the external devices to be connected to the module by referring to the performance specifications in this manual and considering the maximum inrush current. Connecting a device exceeding the maximum inrush current may cause malfunction or failure of the module.
  - During control of an inductive load such as a lamp, heater, or solenoid valve, a large current (approximately ten times greater than normal) may flow when the output is turned from off to on. Therefore, use a module that has a sufficient current rating.
- 

## [Security Precautions]

---

### **WARNING**

- To maintain the security (confidentiality, integrity, and availability) of the programmable controller and the system against unauthorized access, denial-of-service (DoS) attacks, computer viruses, and other cyberattacks from external devices via the network, take appropriate measures such as firewalls, virtual private networks (VPNs), and antivirus solutions.
- 

## [Installation Precautions]

---

### **WARNING**

- Shut off the load power supply (all phases) used in the system before mounting or removing a module. Failure to do so may result in electric shock or cause the module to fail or malfunction.
- 

## [Installation Precautions]

---

### **CAUTION**

- Use the module in an environment that meets the general specifications in this manual. Failure to do so may result in electric shock, fire, malfunction, or damage to or deterioration of the product.
  - Do not directly touch any conductive parts and electronic components of the module. Doing so can cause malfunction or failure of the module.
  - Securely fix the module with mounting screws. Failure to do so may cause the module to fail due to increasing effects of vibrations.
  - Securely connect the cable connectors. Poor contact may cause malfunction.
  - After the first use of the product, do not connect/remove the connectors more than 50 times (IEC 61131-2/JIS B 3502 compliant). Exceeding the limit may cause malfunction.
- 

## [Wiring Precautions]

---

### **WARNING**

- Shut off the load power supply (all phases) used in the system before wiring. Failure to do so may result in electric shock or cause the module to fail or malfunction.
-

## [Wiring Precautions]

---

### CAUTION

- Individually ground the FG metal fitting of the programmable controller with a ground resistance of 100 ohms or less. Failure to do so may result in electric shock or malfunction.
  - Check the rated voltage and terminal layout before wiring to the module, and connect the cables correctly. Connecting a power supply with a different voltage rating or incorrect wiring may cause a fire or failure.
  - Tighten the waterproof caps within the specified torque range. Undertightening can cause short circuit, fire, or malfunction. Overtightening can damage the waterproof cap, resulting in short circuit or malfunction.
  - The module meets IP67 only when all of the waterproof plugs and waterproof caps are attached and the cover of the station number setting switch is securely fixed with a screw.
  - Prevent foreign matter such as dust or wire chips from entering the module. Such foreign matter can cause a fire, failure, or malfunction.
  - Place the cables in a duct or clamp them. If not, dangling cable may swing or inadvertently be pulled, resulting in damage to the module or cables or malfunction due to poor contact.
  - Use UL listed cables in the categories "CYJV" and "PVVA", with the suitable voltage, current, and temperature rating (the operating temperature range of the cables: 75°C or higher) for system installation.
  - Do not install the control lines or communication cables together with the main circuit lines or power cables. Keep a distance of 100mm or more between them. Failure to do so may result in malfunction due to noise.
  - When disconnecting the cable from the module, do not pull the cable by the cable part. For the cable with connector, hold the connector part of the cable. Pulling the cable connected to the module may result in malfunction or damage to the module or cable.
  - When an overcurrent caused by an error of an external device or a failure of the programmable controller flows for a long time, it may cause smoke and fire. To prevent this, configure an external safety circuit, such as a fuse.
  - Wiring and replacement of a module must be performed by qualified maintenance personnel with knowledge of protection against electric shock. For wiring methods, refer to "INSTALLATION AND WIRING" in this manual.
- 

## [Startup and Maintenance Precautions]

---

### WARNING

- Do not touch any connector while power is on. Doing so will cause electric shock or malfunction.
  - Shut off the load power supply (all phases) used in the system before cleaning the module or retightening screws or connector screws. Failure to do so may cause the module to fail or malfunction.
-

## [Startup and Maintenance Precautions]

---

### **CAUTION**

- Do not disassemble or modify the module. Doing so may cause failure, malfunction, injury, or a fire.
  - Do not drop or apply strong shock to the module. Doing so may damage the module.
  - Shut off the load power supply (all phases) used in the system before mounting or removing a module. Failure to do so may cause the module to fail or malfunction.
  - After the first use of the product, do not connect/remove the connectors more than 50 times (IEC 61131-2/JIS B 3502 compliant). Exceeding the limit may cause malfunction.
  - Before handling the module or connection cables, touch a conducting object such as a grounded metal to discharge the static electricity from the human body. Failure to do so may cause the module to fail or malfunction.
  - Startup and maintenance of a control panel must be performed by qualified maintenance personnel with knowledge of protection against electric shock. Lock the control panel so that only qualified maintenance personnel can operate it.
- 

## [Disposal Precautions]

---

### **CAUTION**

- When disposing of this product, treat it as industrial waste.
- 

## [Transportation Precautions]

---

### **CAUTION**

- For shipping, always use the original packaging.
-

# CONDITIONS OF USE FOR THE PRODUCT

---

- (1) Although Mitsubishi Electric has obtained the certification for Product's compliance to the international safety standards IEC61508, ISO13849-1 from TUV Rheinland, this fact does not guarantee that Product will be free from any malfunction or failure. The user of this Product shall comply with any and all applicable safety standard, regulation or law and take appropriate safety measures for the system in which the Product is installed or used and shall take the second or third safety measures other than the Product. Mitsubishi Electric is not liable for damages that could have been prevented by compliance with any applicable safety standard, regulation or law.
- (2) Mitsubishi Electric prohibits the use of Products with or in any application involving, and Mitsubishi Electric shall not be liable for a default, a liability for defect warranty, a quality assurance, negligence or other tort and a product liability in these applications.
  - (a) power plants,
  - (b) trains, railway systems, airplanes, airline operations, other transportation systems,
  - (c) hospitals, medical care, dialysis and life support facilities or equipment,
  - (d) amusement equipments,
  - (e) incineration and fuel devices,
  - (f) handling of nuclear or hazardous materials or chemicals,
  - (g) mining and drilling,
  - (h) and other applications where the level of risk to human life, health or property are elevated.
- (3) Mitsubishi Electric shall have no responsibility or liability for any problems involving programmable controller trouble and system trouble caused by DoS attacks, unauthorized access, computer viruses, and other cyberattacks.

## INTRODUCTION

---

Thank you for purchasing the CC-Link IE Field Network waterproof/dustproof remote I/O module (with safety functions) (hereafter abbreviated as safety remote I/O module).

This manual describes the specifications, procedures before operation, installation and wiring, functions, parameter settings, maintenance and inspection, and troubleshooting of the safety remote I/O module.

Before using this product, please read this manual and the relevant manuals carefully and develop familiarity with the functions and performance of the safety remote I/O module to handle the product correctly. When applying the program and circuit examples provided in this manual to an actual system, ensure the applicability and confirm that it will not cause system control problems.

Please make sure that the end users read this manual.

### Point

Unless otherwise specified, this manual describes the examples in which the safety remote I/O signals and remote I/O signals of the safety remote I/O module are assigned as follows.

- Safety remote input: SA1X0 to SA1X1B
- Safety remote output: SA1Y0 to SA1Y3
- Remote input signal: RX0 to RX4F
- Remote output signal: RY0 to RY4F
- Remote register: RWr0 to RWrB, RWw0 to RWwB

For how to assign remote I/O signals and remote register, refer to the following.

 User's manual for the master/local module used

---



# CONTENTS

COPYRIGHT .....	1
PRECAUTIONS REGARDING WARRANTY .....	1
SAFETY PRECAUTIONS .....	2
CONDITIONS OF USE FOR THE PRODUCT .....	6
INTRODUCTION .....	6
RELEVANT MANUALS .....	10
TERMS .....	11
<b>CHAPTER 1 PRODUCT LINEUP</b> .....	<b>13</b>
1.1 Safety Remote I/O Module .....	13
1.2 Recommended Connector List .....	14
<b>CHAPTER 2 PART NAMES</b> .....	<b>16</b>
<b>CHAPTER 3 SPECIFICATIONS</b> .....	<b>19</b>
3.1 General Specifications .....	19
3.2 Performance Specifications .....	20
3.3 Function List .....	28
<b>CHAPTER 4 PROCEDURES BEFORE OPERATION</b> .....	<b>31</b>
<b>CHAPTER 5 SYSTEM CONFIGURATION</b> .....	<b>33</b>
5.1 Applicable Systems .....	33
5.2 Safety Standards .....	34
5.3 Safety Parameters .....	34
<b>CHAPTER 6 INSTALLATION AND WIRING</b> .....	<b>35</b>
6.1 Setting the Station Number .....	35
Setting the station number with the station number setting switch .....	35
6.2 Installation Environment and Installation Position .....	37
Installation environment .....	37
Installation position .....	38
Installation direction .....	38
6.3 Installation .....	39
Fixing the safety remote I/O module .....	39
6.4 Wiring .....	40
Wiring the power supply .....	40
Wiring of Ethernet cable .....	41
Attaching waterproof caps .....	43
Precautions for wiring the safety remote I/O module to safety devices .....	44
<b>CHAPTER 7 FUNCTIONS</b> .....	<b>45</b>
7.1 Input Function .....	45
Input wiring selection function .....	45
Input ON delay, input OFF delay functions .....	49
7.2 Output Function .....	50
Output wiring selection function .....	50
7.3 Input Diagnostic Function .....	53

Double input discrepancy detection function . . . . .	53
Input dark test function . . . . .	55
<b>7.4 Output Diagnostic Function . . . . .</b>	<b>57</b>
Output dark test function . . . . .	57
Output read-back function . . . . .	59
<b>7.5 User Authentication Function . . . . .</b>	<b>60</b>
<b>7.6 Protection Functions. . . . .</b>	<b>61</b>
<b>CHAPTER 8 PARAMETER SETTINGS . . . . .</b>	<b>62</b>
<hr/>	
<b>8.1 Module Parameter Setting of the Master Station . . . . .</b>	<b>64</b>
Module parameter setting procedure. . . . .	65
<b>8.2 Module Parameter Setting . . . . .</b>	<b>67</b>
Module parameter setting procedure. . . . .	67
Module parameter list . . . . .	72
<b>CHAPTER 9 MAINTENANCE AND INSPECTION . . . . .</b>	<b>77</b>
<hr/>	
<b>9.1 Daily Inspection. . . . .</b>	<b>77</b>
<b>9.2 Periodic Inspection . . . . .</b>	<b>78</b>
<b>CHAPTER 10 TROUBLESHOOTING . . . . .</b>	<b>79</b>
<hr/>	
<b>10.1 Checking the LEDs . . . . .</b>	<b>79</b>
<b>10.2 Checking Module Status. . . . .</b>	<b>83</b>
Checking with the engineering tool . . . . .	83
<b>10.3 Checking Network Status . . . . .</b>	<b>86</b>
<b>10.4 Unit Test . . . . .</b>	<b>88</b>
<b>10.5 Troubleshooting by Symptom . . . . .</b>	<b>89</b>
<b>10.6 Fault Examples with the Safety Remote I/O Module . . . . .</b>	<b>91</b>
Troubleshooting for input circuit . . . . .	91
Troubleshooting for output circuit . . . . .	93
<b>10.7 Error Code List . . . . .</b>	<b>95</b>
Error codes related to the safety remote I/O module. . . . .	95
Error codes related to CC-Link IE Field Network. . . . .	100
Error codes related to safety communication . . . . .	102
<b>APPENDICES . . . . .</b>	<b>104</b>
<hr/>	
<b>Appendix 1 Safety Remote I/O Signals . . . . .</b>	<b>104</b>
Lists of safety remote I/O signals . . . . .	105
Details of safety remote I/O signals. . . . .	107
<b>Appendix 2 Remote I/O Signals . . . . .</b>	<b>108</b>
List of remote I/O signals. . . . .	108
Details of remote I/O signals . . . . .	109
<b>Appendix 3 Remote Register . . . . .</b>	<b>112</b>
<b>Appendix 4 Remote Buffer Memory . . . . .</b>	<b>113</b>
Lists of remote buffer memory areas. . . . .	114
Details of remote buffer memory areas . . . . .	118
<b>Appendix 5 EMC, Low Voltage, and Machinery Directives. . . . .</b>	<b>126</b>
Measures to comply with the EMC Directive . . . . .	126
Requirements to compliance with the Low Voltage Directive . . . . .	129
Measures to comply with the Machinery Directive . . . . .	129
<b>Appendix 6 How to Check Serial Number and Function Version . . . . .</b>	<b>130</b>

Appendix 7 External Dimensions .....	131
<b>INDEX</b>	<b>133</b>
<hr/>	
REVISIONS .....	135
WARRANTY .....	136
TRADEMARKS .....	138

# RELEVANT MANUALS





## Manuals relevant to CC-Link IE Field Network

When using CC-Link IE Field Network for the first time, refer to the CC-Link IE Field Network master/local module user's manuals first. The CC-Link IE Field Network manuals are organized as follows.

Manual name [manual number]	Description	Available form
CC-Link IE Field Network Waterproof/Dustproof Remote I/O Module (With Safety Functions) User's Manual [SH-082076ENG] (this manual)	Specifications, procedures before operation, installation and wiring, functions, parameter settings, maintenance and inspection, and troubleshooting of the safety remote I/O module	Print book e-Manual PDF
MELSEC iQ-R Ethernet/CC-Link IE User's Manual (Startup) [SH-081256ENG]	Specifications, procedures before operation, system configuration, wiring, and communication examples of Ethernet, CC-Link IE Controller Network, and CC-Link IE Field Network	Print book e-Manual PDF
MELSEC iQ-R CC-Link IE Field Network User's Manual (Application) [SH-081259ENG]	Functions, parameter settings, programming, troubleshooting, I/O signals, and buffer memory of CC-Link IE Field Network	Print book e-Manual PDF
MELSEC iQ-R Programming Manual (Module Dedicated Instructions) [SH-081976ENG]	Dedicated instructions for the intelligent function modules	e-Manual PDF
MELSEC iQ-R Simple Motion Module User's Manual (Network) [IB-0300307ENG]	Functions, parameter settings, troubleshooting, and buffer memory of CC-Link IE Field Network	Print book e-Manual PDF
MELSEC iQ-R Simple Motion Module User's Manual (Application) [IB-0300247ENG]	Functions, parameter settings, I/O signals, buffer memory, programming, and troubleshooting of the Simple Motion module	Print book e-Manual PDF
MELSEC iQ-R Simple Motion Module User's Manual (Advanced Synchronous Control) [IB-0300249ENG]	Functions related to the synchronous control, and programming of the Simple Motion module	Print book e-Manual PDF

# TERMS

Unless otherwise specified, this manual uses the following terms.

Term	Description
Buffer memory	A memory in an intelligent function module, where data (such as setting values and monitoring values) exchanged with a Safety CPU are stored
CC-Link IE Field Network	A high-speed and large-capacity open field network that is based on Ethernet (1000BASE-T)
Cyclic transmission	A function by which data are periodically exchanged among stations on the same network using link devices (RX, RY, RWw, and RWr)
Dark test	A function that diagnoses contacts including external devices using OFF pulses
Data link	A generic term for cyclic transmission and transient transmission
Dedicated instruction	An instruction that simplifies programming for using functions of intelligent function modules
Disconnection	A process of stopping data link if a data link error occurs
Engineering tool	The product name of the software package for the MELSEC programmable controllers
Initial processing state	The state of having set the minimum required parameters on the module, so that data communication with external devices is possible
Link special register (SW)	Word data that indicates the operating status and data link status of a module on CC-Link IE Field Network
Link special relay (SB)	Bit data that indicates the operating status and data link status of a module on CC-Link IE Field Network
Local station	A station that performs cyclic transmission and transient transmission with the master station and other local stations. The station is controlled by programs in the Safety CPU or other equivalent modules on the station.
Loopback	A function that, upon occurrence of an error, disconnects only the station where the error occurred, and maintains data links only with the normally operating stations. Data links can be maintained even with normally operating stations connected past the faulty station whose line was disconnected.
Master station	A station that controls the entire network. This station can perform cyclic transmission and transient transmission with all stations. Only one master station can be used in a network.
Master/local module	An abbreviation for the CC-Link IE Field Network master/local module
NC	An abbreviation for a normally closed contact. The contact opens with an operation (such as switch operation).
NO	An abbreviation for a normally open contact. The contact closes with an operation (such as switch operation).
REMFR	An abbreviation for ZP.REMFR.
Remote buffer memory	Buffer memory in a remote device station and intelligent device station
Remote device station	A station that exchanges I/O signals (bit data) and I/O data (word data) with another station by cyclic transmission. This station responds to a transient transmission request from another station.
Remote input (RX)	Bit data input from a slave station to the master station (For some areas in a local station, data are input in the opposite direction.)  User's manual for the master/local module used
Remote output (RY)	Bit data output from the master station to a slave station (For some areas in a local station, data are output in the opposite direction.)  User's manual for the master/local module used
Remote register (RWr)	Word data input from a slave station to the master station (For some areas in a local station, data are input in the opposite direction.)  User's manual for the master/local module used
Remote register (RWw)	Word data output from the master station to a slave station (For some areas in a local station, data are output in the opposite direction.)  User's manual for the master/local module used
REMTO	An abbreviation for ZP.REMTO.
Reserved station	A station reserved for future use. This station is not actually connected, but counted as a connected station
Safety category	A safety level specified in EN954-1 The safety level is divided into 5 levels (B, 1 to 4).
Safety device	A device that can be used in safety programs
Safety function	A function provided to protect a person from the hazards of machines
Safety remote I/O module	A generic term for the NZ2GFS12A2-16DTE and the NZ2GFS12A2-14DT
Safety remote input (SAIX)	A safety device (safety input) that can be used in safety programs
Safety remote output (SAIY)	A safety device (safety output) that can be used in safety programs
Safety remote station	A remote station to perform safety communications
Sink output	A output in which a current flows from the load into the output terminal when the output transistor turns on
Slave station	A generic term for stations other than a master station: local station, remote I/O station, remote device station, and intelligent device station
Source output	A output in which a current flows out from the output terminal to the load when the output transistor turns on

<b>Term</b>	<b>Description</b>
Transient transmission	A function of communication with another station, which is used when requested by a dedicated instruction or an engineering tool

# 1 PRODUCT LINEUP

## 1.1 Safety Remote I/O Module

### Safety remote I/O module

The following table lists the safety remote I/O module product lineup.

Type		Specifications	Module power supply current	Weight	Model	Reference
Input part	Negative common type	Waterproof connector 24VDC, 12 points	190mA	0.89kg	NZ2GFS12A2-16DTE	Page 20 NZ2GFS12A2-16DTE safety remote I/O module
Output part	Source + source type	Waterproof connector 24VDC, 1.0A/1 point, 4 points				
Input part	Negative common type	Waterproof connector 24VDC, 12 points	190mA	0.89kg	NZ2GFS12A2-14DT	Page 24 NZ2GFS12A2-14DT safety remote I/O module
Output part	Source + sink type	Waterproof connector 24VDC, 2.0A/1 point, 2 points				

## 1.2 Recommended Connector List

The following table lists applicable waterproof connectors.

□ of a model name indicates a numerical value representing the length of each cable.

For details on applicable waterproof connectors, refer to the website of each manufacturer.

### For power supply

The following table lists applicable waterproof connectors for power supply.

Type		Model	Connection cable diameter	Manufacturer
Connector	Cable			
7/8" 5 pins Male (OUT)	—	1A5006-34	φ5.08 to 11.43mm	Molex, LLC
7/8" 5 pins Female (IN)		1A5000-34		
7/8" 5 pins Male (OUT)		105006K13M□	—	
7/8" 5 pins Female (IN)		105000K13M□		
7/8" 5 pins Male (OUT)-Female (IN)		115030K13M□		

### For I/O

The following table lists applicable waterproof connectors for I/O.

Type		Model	Connection cable diameter	Manufacturer
Connector	Cable			
M12 5 pins Male (one-touch)	A code	WA5006-31	φ3.3 to 6.6mm	Molex, LLC
		WA5006-32	φ4.1 to 8.1mm	
		W05006E03M□	—	
M12 5 pins Male (one-touch)-Female (screw)		8W5030E03M□	—	
		M12 5 pins Male (screw)	8A5006-31	
8A5006-32			φ4.1 to 8.1mm	
805006J06M□	—			
M12 5 pins Male (screw)-Female (screw)	885030J06M□	—		



## Y-branch connector for I/O

The following table lists applicable Y-branch connectors for I/O.

Type		Model	Connection cable diameter	Manufacturer
Connector	Cable			
M12 5 pins Male	A code	0812-05EMF-00001	—	Molex, LLC

## For communications

The following table lists applicable waterproof connectors for communications.

Type		Model	Connection cable diameter	Manufacturer
Connector	Cable			
M12 8 pins Male	X code-X code	E22E06020M□	—	Molex, LLC
M12 8 pins Male	X code-RJ45	E26E06020M□		
M12 8 pins Male	X code	J80026A0100	φ5.5 to 9.0mm	Telegartner Karl Gartner GmbH
M12 8 pins Male	X code	IE-PS-M12X-P-AWG22/27FH	φ5.5 to 9.0mm	Weidmueller Interface GmbH & Co. KG
—	Cable only	SC-E5EW-□M	—	Mitsubishi Electric System & Service Co., Ltd.

## Waterproof cap

The following table lists applicable waterproof caps.

Type		Model	Connection cable diameter	Manufacturer
Connector	Cable			
M12	—	120358-0007	—	Molex, LLC
7/8" Male (OUT)	—	65-0085	—	
7/8" Female (IN)		65-0086		

# 2 PART NAMES

## Part names of the safety remote I/O module

This section describes the part names of the safety remote I/O module.

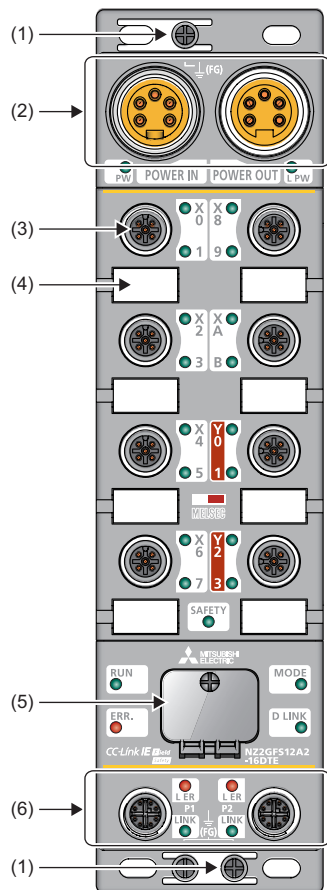

No.	Name	Application
(1)	FG metal fitting	Metal fitting for connecting FG For the tightening torque of screws for the FG metal fitting, refer to the following. ☞ Page 39 Fixing the safety remote I/O module
(2)	Power supply connectors	Connectors for the module power supply (24VDC) and load power supply (24VDC)
(3)	I/O connector	Connector for I/O signals
(4)	Signal label	Label for describing signal names
(5)	Station number setting switch	Rotary switch for setting a station number or tests ☞ Page 35 Setting the Station Number ☞ Page 88 Unit Test
(6)	Communication connectors	P1 PORT1 connector for CC-Link IE Field Network Connect an Ethernet cable. ☞ Page 41 Wiring of Ethernet cable
		P2 PORT2 connector for CC-Link IE Field Network Connect an Ethernet cable. ☞ Page 41 Wiring of Ethernet cable

## Names of the LEDs of the safety remote I/O module

This section describes the names of the LEDs of the safety remote I/O module.

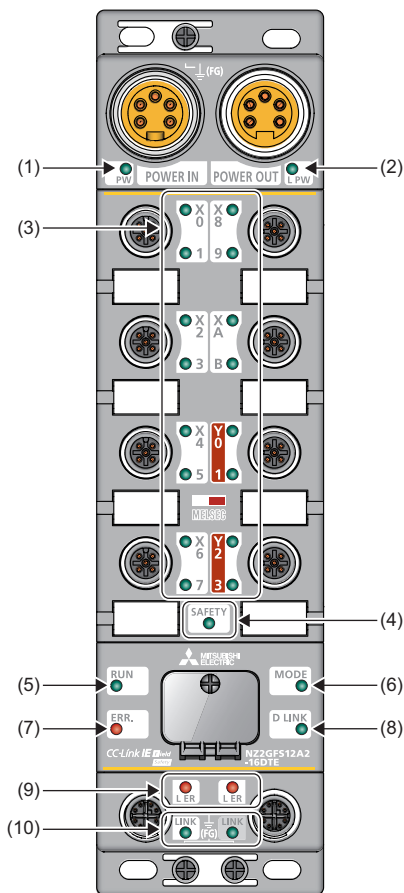

No.	Name	Description
(1)	PW LED	Indicates the voltage status of the module power supply. Green: The module power supply has no voltage error. Red: The module power supply has a voltage error. Off: The module power supply is off or has a voltage error.
(2)	L PW LED	Indicates the voltage status of the load power supply. Green: The load power supply has no voltage error. Red: The load power supply has a voltage error. Off: The load power supply is off or has a voltage error.
(3)	I/O LED	Indicates the on/off state of I/Os. Green: I/O signals are on. Red: An I/O circuit error or double wiring discrepancy was detected. Red (flashing): An error occurred at one terminal of double wiring, or an error common to all I/O circuits except the terminal flashing red occurred. Off: I/O signals are off.
(4)	SAFETY LED	Indicates the safety communication status of the safety remote I/O module. On: Safety communication is established. Off: Safety communication is not established.
(5)	RUN LED	Indicates the operating status of the safety remote I/O module. On: Operating normally. Off: A major error occurred.
(6)	MODE LED	Indicates the mode of the safety remote I/O module. On: The unit test is completed. (online) Flashing: In unit test mode Off: Error occurred, Offline

No.	Name	Description
(7)	ERR. LED	Indicates the error status of the safety remote I/O module. On: A module error occurred. Flashing: A minor error occurred. Off: Operating normally.
(8)	D LINK LED	Indicates the data link status of the safety remote I/O module. On: Communications are normal. Flashing: Communications are interrupted. Off: Disconnected
(9)	L ER LED	Indicates the port status. On: Module received abnormal data, or module performing loopback. Off: Module received normal data, or module not performing loopback.
(10)	LINK LED*1	Indicates the link status. On: Link-up in progress Off: Link-down in progress

\*1 The LINK LED may be on at power-on, but this does not indicate an error.

## Safety remote I/O module status and LED status

This section describes the correspondence between the safety remote I/O module status and the LED status.

Safety remote I/O module status*4		Data link status	LED status					
			PW LED	RUN LED	MODE LED	ERR. LED	D LINK LED	SAFETY LED
Initial processing state		Disconnection	On	Off	Off	Off	Off	Off
Standby mode	Disconnected	Disconnection	On	On	On	Off	Off	Off
	Data link in operation	Data link in operation	On	On	On	Off	On	Off
	Reserved station setting in progress	Cyclic stop	On	On	On	Off	Flashing	Off
	Link stop	Cyclic stop	On	On	On	Off	Flashing	Off
	Checking the position of the setting target module	Data link in operation/ cyclic stop	On	On	On	Off	*5	Flashing
Safety drive mode		Data link in operation	On	On	On	Off	On	On
Unit test	In progress	—	On	On	Flashing	Off	Off	Off
	Normal completion	—	On	On	Off	Off	Off	Off
	Abnormal completion	—	On	On	Off	On	Off	Off
Communication error		Cyclic stop	On	On	On	Off	Flashing	Off
Error	Major error	—	On	Off	*1	On*3	*2	*6
	Moderate error	—	On	On	*1	On	*2	*6
Warning	Minor error	—	On	On	*1	Flashing	*2	*2

\*1 Either On or Off.

\*2 Either On, Flashing, or Off.

\*3 When the module is failed, the LED may not turn on.

\*4 For the status of the module, refer to the following.

 Page 83 Checking Module Status

\*5 Either On or Flashing.

\*6 Either Flashing or Off.

# 3 SPECIFICATIONS

This chapter describes the specifications of the safety remote I/O module.

## 3.1 General Specifications

Item	Specifications					
Operating ambient temperature	0 to 55°C					
Storage ambient temperature	-25 to 75°C					
Operating ambient humidity	Conforming to IP67*1					
Storage ambient humidity	5 to 95%RH, non-condensing					
Vibration resistance	Compliant with JIS B 3502 and IEC 61131-2	—	Frequency	Constant acceleration	Half amplitude	Number of sweeps
		Under intermittent vibration	5 to 8.4Hz	—	3.5mm	10 times each in X, Y, and Z directions
			8.4 to 150Hz	9.8m/s <sup>2</sup>	—	
		Under continuous vibration	5 to 8.4Hz	—	1.75mm	—
8.4 to 150Hz	4.9m/s <sup>2</sup>		—			
Shock resistance	Compliant with JIS B 3502 and IEC 61131-2 (147m/s <sup>2</sup> , 3 times each in X, Y, and Z directions)					
Operating atmosphere	No corrosive gases					
Operating altitude*2	0 to 2000m					
Installation location	Inside/outside a control panel					
Overvoltage category*3	II or less					
Pollution degree*4	2 or less					
Equipment class	Class III					
Safety element	HFT=1, SIL3 PLe, SC 3, Type B					

\*1 Only when all necessary waterproof connectors and caps have been installed and the station number setting switch cover has been properly tightened with a screw, the module conforms to IP67. For the tightening torque range of the screw for the station number setting switch cover, refer to the following.

☞ Page 36 Tightening torque

\*2 Do not use or store the safety remote I/O module under pressure higher than the atmospheric pressure of altitude 0m. Doing so may cause malfunction. When using the safety remote I/O module under pressure, please consult your local Mitsubishi representative.

\*3 This indicates the section of the power supply to which the equipment is assumed to be connected between the public electrical power distribution network and the machinery within premises.

Category II applies to equipment for which electrical power is supplied from fixed facilities. The surge voltage withstand level for the equipment with the rated voltage of 300V or less is 2500V.

\*4 This index indicates the degree to which conductive material is generated in terms of the environment in which the equipment is used. Pollution degree 2 is when only non-conductive pollution occurs. A temporary conductivity caused by condensing must be expected occasionally.

### Point

When complying with the EMC Directive, refer to the following.

☞ Page 126 EMC, Low Voltage, and Machinery Directives

## 3.2 Performance Specifications

### NZ2GFS12A2-16DTE safety remote I/O module

Item	NZ2GFS12A2-16DTE		
	Input specifications	Output specifications	
Station type	Remote device station		
Number of input points	Single wiring: 12 points Double wiring: 6 points	—	
Rated input voltage	24VDC (ripple ratio: 5% or less) (allowable voltage range: 20.4 to 28.8VDC)		
Rated input current	6mA TYP. (24VDC)		
Max. number of simultaneous input points	100%		
ON voltage/ON current	11VDC or higher / 2mA or higher (compliant with IEC 61131-2 Standard digital input type 3)		
OFF voltage/OFF current	5VDC or lower / 1.5mA or lower (compliant with IEC 61131-2 Standard digital input type 3)		
Input type	Negative common		
Input resistance	Approx. 4kΩ		
Input circuit response time	OFF → ON		0.5ms or less (24VDC)
	ON → OFF		1.5ms or less (24VDC)
Safety remote station input response time	Input circuit response time + Input ON/OFF delay setting (0 to 1000ms in 1ms steps) (Initial setting: 5ms)		
Safety refresh response processing time	10ms		
Power supply current for input device <sup>*1</sup>	0.4A/1 terminal		
Number of output points	—		Single wiring: 4 points Double wiring: 2 points
Rated load voltage	24VDC (ripple ratio: 5% or less) (allowable voltage range: 20.4 to 28.8VDC)		
Load power supply	Protection function	Load power supply overvoltage protection function, load power supply overcurrent protection function	
	Max. current	8A	
Max. load current	1.0A/point		
Max. inrush current	Current is limited by the overload protection function.		
Leakage current at OFF	0.1mA or less		
Max. voltage drop at ON	1.0VDC or lower		
Protection function	Output overload short circuit protection		
Double output type	Source + Source type		
Output circuit response time	OFF → ON	10ms	
	ON → OFF	10ms	
Safety remote station output response time	Output circuit response time		
Surge suppressor	Zener diode		
Isolation method	Non-isolation	Photocoupler isolation	
Withstand voltage	500VAC for 1 minute between all DC external terminals and the ground		
Isolation resistance	10MΩ or higher between all DC external terminals and the ground (500VDC isolation resistance tester)		
Protection degree	IP67		
Wiring method for common	Input 12 points/common	Output 4 points/common	
Interval of the input diagnostic function execution	12ms maximum		
Interval of the output diagnostic function execution	2s maximum		

Item		NZ2GFS12A2-16DTE	
		Input specifications	Output specifications
External interface	Module power supply part	7/8" waterproof connector, 5 pins, male (IN)/female (OUT)	
	I/O part	M12 waterproof connector, 5 pins, female, A-code	
	Communication part	M12 waterproof connector, 8 pins, female, X-code	
Applicable waterproof connector	For power supply	☞ Page 14 Recommended Connector List	
	For I/O		
	Y-branch connector for I/O		
	For communications		
Cyclic transmission	RX/RX points	80 points	
	RWr/RWw points	16 points	
	SAIX / SAIY points	SAIX: 28 points SAIY: 4 points	
Communication cable		An Ethernet cable that meets the 1000BASE-T standard: Category 5e or higher (double shielded, STP), straight cable	
Module power supply	Voltage	24VDC (ripple ratio: 5% or less) (allowable voltage range: 20.4 to 28.8VDC)	
	Current (current consumption)	190mA	
	Protection function	Module power supply overvoltage protection function, module power supply overcurrent protection function	
	Max. current	8A	
Weight		0.89kg	

\*1 When using the test pulse output for the power supply for input device, use double insulation cables depending on applications used and the safety category (SIL/CAT) required.

## External connection

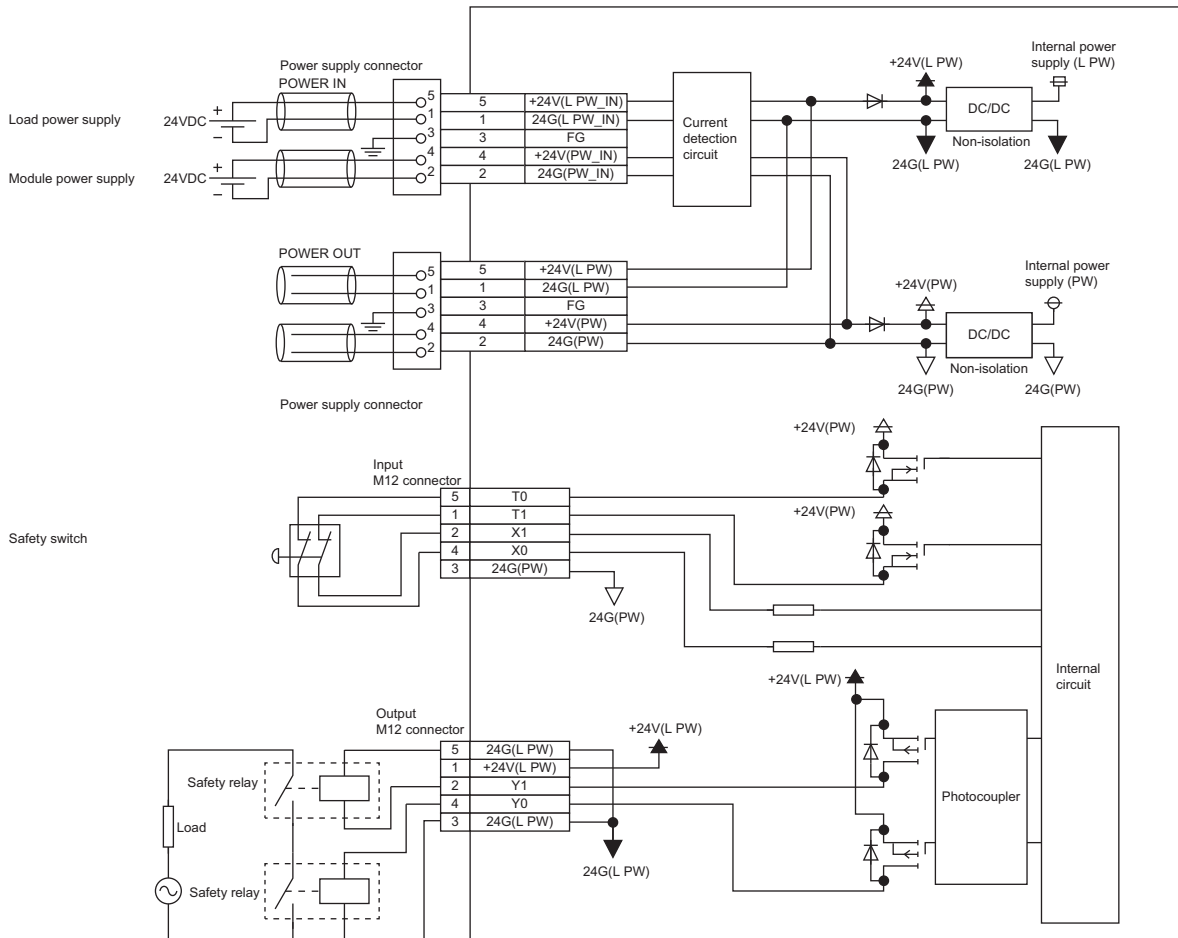

## Power supply connectors

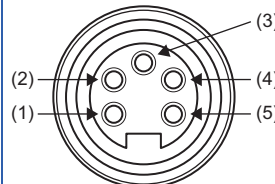
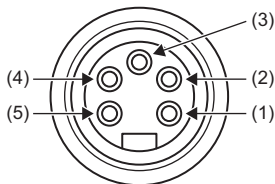

Pin number	Signal name	Pin number	Signal name		
7/8" connector Male (IN)	(1)	24G (L PW_IN)	7/8" connector Female (OUT)	(1)	24G (L PW)
	(2)	24G (PW_IN)		(2)	24G (PW)
	(3)	FG		(3)	FG
	(4)	+24V (PW_IN)		(4)	+24V (PW)
	(5)	+24V (L PW_IN)		(5)	+24V (L PW)



I/O connector

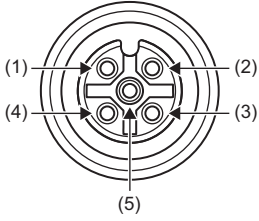

Pin number		Signal name	Pin number		Signal name
X0 X1	(1)	T1	X8 X9	(1)	T9
	(2)	X1		(2)	X9
	(3)	24G (PW)		(3)	24G (PW)
	(4)	X0		(4)	X8
	(5)	T0		(5)	T8
X2 X3	(1)	T3	XA XB	(1)	TB
	(2)	X3		(2)	XB
	(3)	24G (PW)		(3)	24G (PW)
	(4)	X2		(4)	XA
	(5)	T2		(5)	TA
X4 X5	(1)	T5	Y0 Y1	(1)	+24V (L PW)
	(2)	X5		(2)	Y1
	(3)	24G (PW)		(3)	24G (L PW)
	(4)	X4		(4)	Y0
	(5)	T4		(5)	24G (L PW)
X6 X7	(1)	T7	Y2 Y3	(1)	+24V (L PW)
	(2)	X7		(2)	Y3
	(3)	24G (PW)		(3)	24G (L PW)
	(4)	X6		(4)	Y2
	(5)	T6		(5)	24G (L PW)

## NZ2GFS12A2-14DT safety remote I/O module

Item		NZ2GFS12A2-14DT	
		Input specifications	Output specifications
Station type		Remote device station	
Number of input points		Single wiring: 12 points Double wiring: 6 points	
Rated input voltage		24VDC (ripple ratio: 5% or less) (allowable voltage range: 20.4 to 28.8VDC)	
Rated input current		6mA TYP. (24VDC)	
Max. number of simultaneous input points		100%	
ON voltage/ON current		11VDC or higher / 2mA or higher (compliant with IEC 61131-2 Standard digital input type 3)	
OFF voltage/OFF current		5VDC or lower / 1.5mA or lower (compliant with IEC 61131-2 Standard digital input type 3)	
Input type		Negative common	
Input resistance		Approx. 4kΩ	
Input circuit response time	OFF → ON	0.5ms or less (24VDC)	
	ON → OFF	1.5ms or less (24VDC)	
Safety remote station input response time		Input circuit response time + Input ON/OFF delay setting (0 to 1000ms in 1ms steps) (Initial setting: 5ms)	
Safety refresh response processing time		10ms	
Power supply current for input device*1		0.4A/1 terminal	
Number of output points		—	
Rated load voltage		24VDC (ripple ratio: 5% or less) (allowable voltage range: 20.4 to 28.8VDC)	
Load power supply	Protection function	Load power supply overvoltage protection function, load power supply overcurrent protection function	
	Max. current	8A	
Max. load current		2.0A/point	
Max. inrush current		Current is limited by the overload protection function.	
Leakage current at OFF		0.1mA or less	
Max. voltage drop at ON		1.0VDC or lower	
Protection function		Output overload short circuit protection	
Double output type		Source + sink type	
Output circuit response time	OFF → ON	10ms	
	ON → OFF	10ms	
Safety remote station output response time		Output circuit response time	
Surge suppressor		Zener diode	
Isolation method		Non-isolation	Photocoupler isolation
Withstand voltage		500VAC for 1 minute between all DC external terminals and the ground	
Isolation resistance		10MΩ or higher between all DC external terminals and the ground (500VDC isolation resistance tester)	
Protection degree		IP67	
Wiring method for common		Input 12 points/common	Output 4 points/common
Interval of the input diagnostic function execution		12ms maximum	
Interval of the output diagnostic function execution		2s maximum	
External interface	Module power supply part	7/8" waterproof connector, 5 pins, male (IN)/female (OUT)	
	I/O part	M12 waterproof connector, 5 pins, female, A-code	
	Communication part	M12 waterproof connector, 8 pins, female, X-code	

Item		NZ2GFS12A2-14DT	
		Input specifications	Output specifications
Applicable waterproof connector	For power supply	☞ Page 14 Recommended Connector List	
	For I/O		
	Y-branch connector for I/O		
	For communications		
Cyclic transmission	RX/RY points	80 points	
	RWr/RWw points	16 points	
	SA\X / SA\Y points	SA\X: 28 points SA\Y: 4 points	
Communication cable		An Ethernet cable that meets the 1000BASE-T standard: Category 5e or higher (double shielded, STP), straight cable	
Module power supply	Voltage	24VDC (ripple ratio: 5% or less) (allowable voltage range: 20.4 to 28.8VDC)	
	Current (current consumption)	190mA	
	Protection function	Module power supply overvoltage protection function, module power supply overcurrent protection function	
	Max. current	8A	
Weight		0.89kg	

\*1 When using the test pulse output for the power supply for input device, use double insulation cables depending on applications used and the safety category (SIL/CAT) required.

## External connection

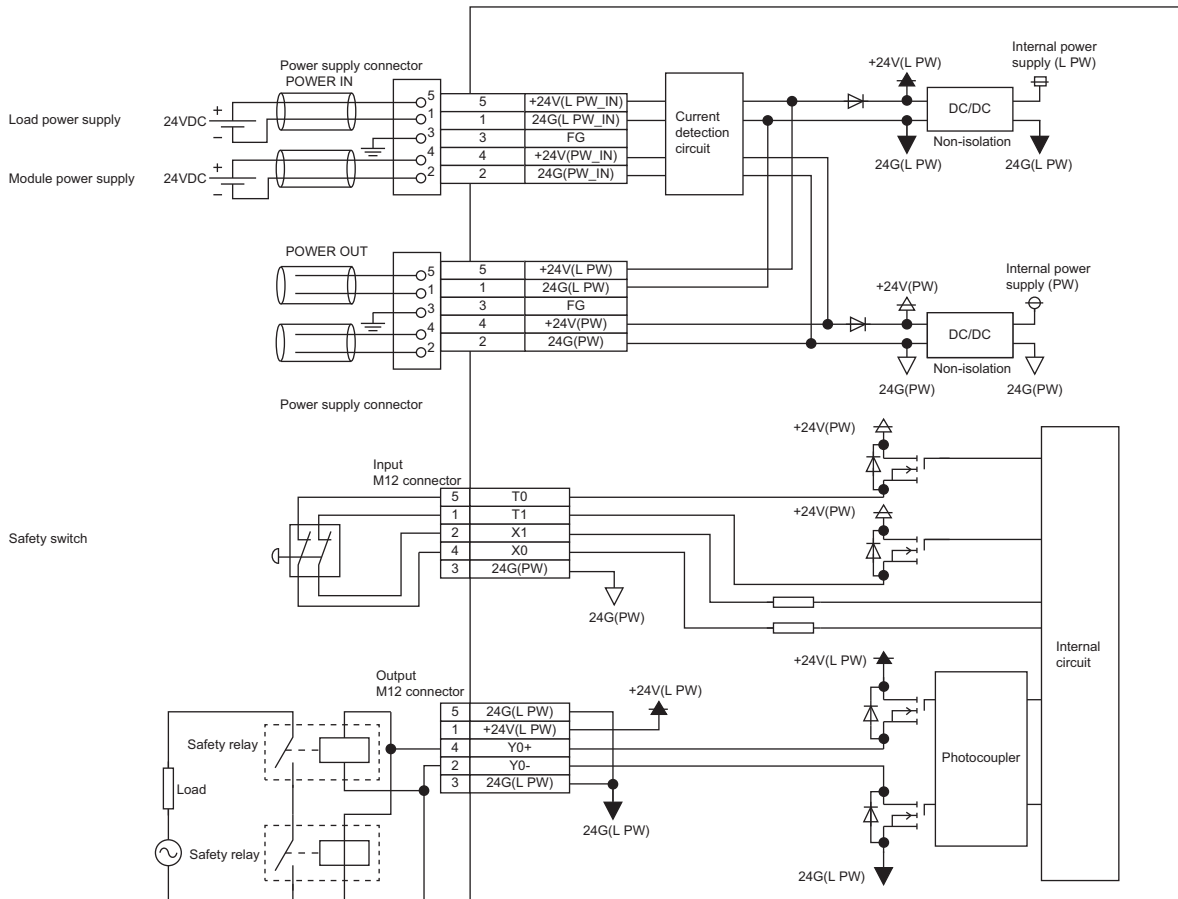

## Power supply connectors

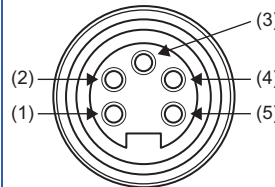
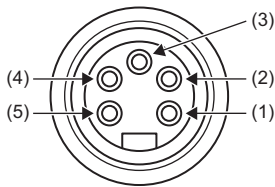

Pin number	Signal name	Pin number	Signal name		
7/8" connector Male (IN)	(1)	24G (L PW_IN)	7/8" connector Female (OUT)	(1)	24G (L PW)
	(2)	24G (PW_IN)		(2)	24G (PW)
	(3)	FG		(3)	FG
	(4)	+24V (PW_IN)		(4)	+24V (PW)
	(5)	+24V (L PW_IN)		(5)	+24V (L PW)

## I/O connector

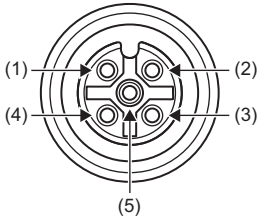

Pin number		Signal name	Pin number		Signal name
X0 X1	(1)	T1	X8 X9	(1)	T9
	(2)	X1		(2)	X9
	(3)	24G (PW)		(3)	24G (PW)
	(4)	X0		(4)	X8
	(5)	T0		(5)	T8
X2 X3	(1)	T3	XA XB	(1)	TB
	(2)	X3		(2)	XB
	(3)	24G (PW)		(3)	24G (PW)
	(4)	X2		(4)	XA
	(5)	T2		(5)	TA
X4 X5	(1)	T5	Y0	(1)	+24V (L PW)
	(2)	X5		(2)	Y0-
	(3)	24G (PW)		(3)	24G (L PW)
	(4)	X4		(4)	Y0+
	(5)	T4		(5)	24G (L PW)
X6 X7	(1)	T7	Y1	(1)	+24V (L PW)
	(2)	X7		(2)	Y1-
	(3)	24G (PW)		(3)	24G (L PW)
	(4)	X6		(4)	Y1+
	(5)	T6		(5)	24G (L PW)

### Safety remote I/O module safety response time

The safety response time of the safety remote I/O module is shown below.

For the response time including the network delay time, refer to the following.

Mitsubishi Electric Safety Programmable Controller MELSEC iQ-R Series Machinery Directive (2006/42/EC) Compliance

#### ■Input

Transmission interval monitoring time × 2 + Safety remote station input response time

#### ■Output

Transmission interval monitoring time × 2 + Safety remote station output response time

## 3.3 Function List

This section describes the function list, operation modes, and state transition.

### Function list

#### ■I/O functions

Function name		Description	Reference
Input function	Input wiring selection function	This function selects double wiring or single wiring of the input wiring.	Page 45 Input wiring selection function
	Input ON delay, input OFF delay functions	This function changes an input signal when a predetermined time has passed after an actual input change. A delay time can be set for each input change pattern, OFF to ON or ON to OFF. In addition, the function prevents incorrect inputs caused by noise since a pulse of a certain time length is not taken in a module.	Page 49 Input ON delay, input OFF delay functions
Output function	Output wiring selection function	This function selects double wiring or single wiring of the output wiring.	Page 50 Output wiring selection function

#### ■Safety functions

Function name		Description	Reference
Input diagnostic function	Double input discrepancy detection function	This function discriminates failures by monitoring the discrepancy state of doubled safety remote inputs (SAIX). When the discrepancy state is detected, a minor error occurs. The module will recover from the error by eliminating its cause.	Page 53 Double input discrepancy detection function
	Input dark test function	This function outputs test pulses to turn off the external input signals (X0 to XB) that are on for a short time and diagnoses contacts including external devices for failure. When failure is detected, a minor error occurs. The module will recover from the error by eliminating its cause.*1 To use this function, settings of "Input mode setting" and "Input test pulse setting" are required.	Page 55 Input dark test function
Output diagnostic function	Output dark test function	This function outputs test pulses to turn off the external output signals (NZ2GFS12A2-16DTE: Y0 to Y3, NZ2GFS12A2-14DT: Y0 to Y1) that are on for a short time and diagnoses the internal circuit for failure. When failure is detected, a minor error occurs. The module will recover from the error by eliminating its cause.*1	Page 57 Output dark test function
	Output read-back function	This function reads back output results and diagnoses whether the external output signals (NZ2GFS12A2-16DTE: Y0 to Y3, NZ2GFS12A2-14DT: Y0 to Y1) are correctly output. When an incorrect output is detected, a minor error occurs. The module will recover from the error by eliminating its cause.*1	Page 59 Output read-back function

\*1 This operation differs from the operation of CC-Link IE Field Network remote I/O module (with safety functions). For the system, configure an external interlock circuit or an interlock circuit using a ladder program. Do not use a stop of safety remote I/O module as an interlock condition.

For the operation of CC-Link IE Field Network remote I/O module (with safety functions), refer to the following.

 CC-Link IE Field Network Remote I/O Module (With Safety Functions) User's Manual

## ■Network function

Function name	Description	Reference
User authentication function	This function limits the users who can access the Safety CPU or safety remote I/O module.	Page 60 User Authentication Function

## ■Module function

Function name	Description	Reference
Protection function	This function protects the internal circuit from overvoltage or overcurrent.	Page 61 Protection Functions

### Point

The safety remote I/O module does not support the CC-Link IE Field Network synchronous communication function.

## Operation mode and state transition

The following describes the state transition and transition conditions of the safety remote I/O module.

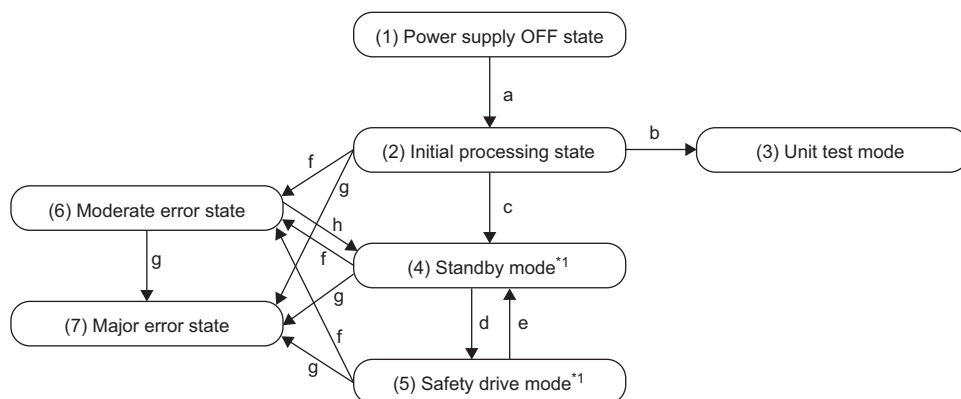

\*1 When a moderate error or major error has occurred, the state is changed into an error state.

### Operation mode/state

No.	Mode/state	Description
(1)	Power supply OFF state	The power supply is not turned on. Change the station number using the station number setting switch or wire the module at this state. ☞ Page 35 INSTALLATION AND WIRING
(2)	Initial processing state	The initial processing is performed at this state.
(3)	Unit test mode	The unit test is performed at this state. ☞ Page 88 Unit Test
(4)	Standby mode	The safety functions of the safety remote I/O module do not operate at this state. Set parameters in this mode. ☞ Page 62 PARAMETER SETTINGS
(5)	Safety drive mode	The safety functions of the safety remote I/O module operate at this state.
(6)	Moderate error state	A moderate error has occurred.
(7)	Major error state	A major error has occurred.

### Transition condition

Symbol	Transition condition
a	When the module is powered on
b	When the station number setting switch ×10 is set to TEST and the station number setting switch ×1 is set to 0 in the power supply OFF state
c	When the initial processing is completed successfully
d	When Safety module enabled flag (address: 1005H) is on and the safety communication with the master station is established For Safety module enabled flag (address: 1005H), refer to the following. ☞ Page 125 Safety module enabled flag (address: 1005H)
e	When the safety communication is disconnected
f	When a moderate error has occurred
g	When a major error has occurred
h	When a parameter data error is eliminated. For parameter data errors, refer to the following. ☞ Page 95 Error Code List

#### Point

To switch the operation mode/state from the unit test mode, moderate error state, or major error state, power off and on the module.



# 4 PROCEDURES BEFORE OPERATION

## Consideration of system configuration

Complete the following items prior to the module installation.

1. Determine a safety category required for configuring the safety system.
2. Determine function wiring required for configuring the safety system.
3. Determine the network number and station number of the safety remote I/O module.

## Module mounting, wiring, and parameter setting

### 1. Mounting the module

Fix the safety remote I/O module with screws.

☞ Page 37 Installation Environment and Installation Position

### 2. Wiring to the power supply module

Connect the safety remote I/O module to the power supply.

☞ Page 40 Wiring the power supply

### 3. Station number setting

Set station numbers of the safety remote I/O module using the station number setting switch.

☞ Page 35 Setting the station number with the station number setting switch

### 4. Wiring

Connect the Ethernet cable and external devices to the safety remote I/O module.

☞ Page 41 Wiring of Ethernet cable

### 5. Powering on the safety remote I/O module

Stop the Safety CPU, and power on the safety remote I/O module.

### 6. Parameter setting

Set the module parameters of the master station module and the safety remote I/O module in the engineering tool.

☞ Page 62 PARAMETER SETTINGS

☞ Page 64 Module Parameter Setting of the Master Station

☞ Page 67 Module Parameter Setting

### 7. Checking the entire system

According to the manuals of the Safety CPU and the master station module, check the entire system for wiring, the station number setting switch, and so on.

### 8. Validating the safety remote I/O module

Enable the module parameters of the safety remote I/O module.

☞ Page 67 Module parameter setting procedure

### 9. Starting the system

Change the status of the Safety CPU to RUN.

### 10. Starting the system operation



To replace the module, follow the procedure described below:

- Turn off the module power supply and remove the safety remote I/O module.
- Prepare a new safety remote I/O module and perform the procedure above from "Mounting the module" to "Parameter setting". (The network parameter of the master station does not need to be set again.)
- After checking the operation, restart the control.

# MEMO

---

# 5 SYSTEM CONFIGURATION

This chapter describes the system configuration using a safety remote I/O module.  
For CC-Link IE Field Network configuration, refer to the following.

 User's manual for the master/local module used

## 5.1 Applicable Systems

### Applicable products

When using a safety remote I/O module, use the following products.

For the model of the Safety CPU and safety function module, refer to the following.

 MELSEC iQ-R Module Configuration Manual

Module	Firmware version
Safety CPU (RnSFCPU)	01 or later
Safety function module (R6SFM)	01 or later
Master station (RJ71GF11-T2)	09 or later
Master station (RD77GF4, RD77GF8, RD77GF16, RD77GF32)	05 or later

Information on "Master station" described above is the ones at the point when this manual was issued.

For latest information, please visit the website of CC-Link Partner Association.

[www.cc-link.org](http://www.cc-link.org)

#### Point

The safety remote I/O module cannot be used with a CPU module other than the Safety CPU.

### Ethernet cable

For the specifications of the Ethernet cable, refer to the following.

 MELSEC iQ-R Ethernet/CC-Link IE User's Manual (Startup)

### Software package

The following engineering tool is required for the safety remote I/O module setting and CC-Link IE Field Network diagnostics.

Product name	Version
GX Works3	1.050C or later

#### Point

When the latest profile of the safety remote I/O module is necessary, please consult your local Mitsubishi representative.

The profile is a setting file that stores information required for the start-up, operation, and maintenance of devices supporting the CC-Link family. A module is added to "Module List" of "CC IE Field Configuration" window by profile registration to an engineering tool. For the profile registration, refer to the following.

 GX Works3 Operating Manual

## 5.2 Safety Standards

Observe the following safety standards.

Region	Standard
Global	IEC 61508: 2010, IEC 62061: 2012, ISO 13849-1 IEC 61131-2 IEC 61000-6-2, IEC 61000-6-4 IEC 61784-3 IEC 60204-1 IEC 61326-3-1
Europe	EN ISO13849-1 EN 61131-2 EN 61000-6-2, EN 61000-6-4
North America	UL 61010-1, UL 61010-2-201

## 5.3 Safety Parameters

The following table lists safety parameters of the safety remote I/O module.

Item	NZ2GFS12A2-16DTE	NZ2GFS12A2-14DT
PFDavg <sup>*1</sup>	$4.07 \times 10^{-4}$	$4.07 \times 10^{-4}$
PFH <sup>*1</sup>	$4.70 \times 10^{-9}$	$4.69 \times 10^{-9}$
DCavg	96.28%	96.24%
MTTFd	108 years	109 years
MTBF	195.7 years (40°C)	207.4 years (40°C)

\*1 Proof test interval is 20 years (module exchange interval).

# 6 INSTALLATION AND WIRING

This chapter describes the installation and wiring of the safety remote I/O module.

## 6.1 Setting the Station Number

### Setting the station number with the station number setting switch

#### Setting procedure

Set a station number with the station number setting switch on the front of the module. The setting value of the station number becomes valid when the module is powered on. Thus, set the station number when the module is powered off.

1. Loosen the screw for the station number setting switch cover with a screwdriver and open the cover.

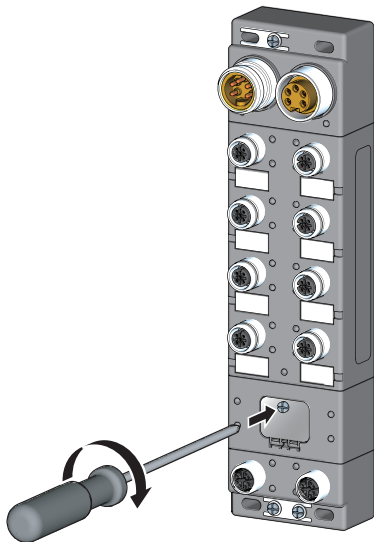
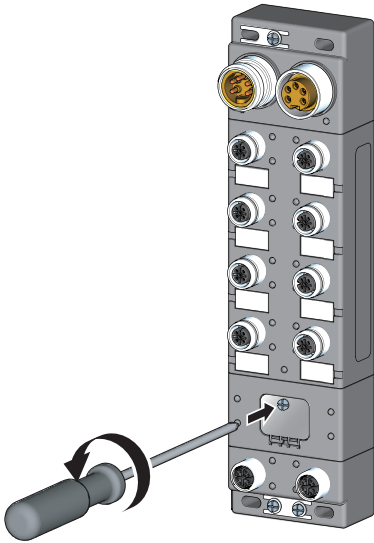

2. Set a station number.\*<sup>1</sup>
  - The hundreds and tens places of the station number are set with x10.
  - The ones place of the station number is set with x1.
3. After setting the station number with the station number setting switch, always close the station number setting switch cover and tighten the screw for the cover with a screwdriver.\*<sup>2</sup> When the cover is open or the screw has not been tightened properly, waterproof performance is lost.

\*<sup>1</sup> When operating the station number setting switch, use a flathead screwdriver with 3.5mm or less width of the tip.

\*<sup>2</sup> For the tightening torque range of the screw for the station number setting switch cover, refer to the following.

☞ Page 36 Tightening torque

Ex.

To set the station to 115, set the switch as shown below.

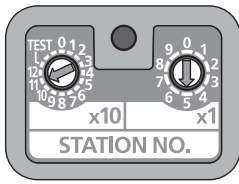

## Setting range

Set the station number from 1 to 120. Setting the value other than 1 to 120 causes a communication error and the D LINK LED flashes.

### Point

- Do not change the station number setting switch while the module power supply is on. Changing the station number setting switch causes a minor error and the ERR. LED flashes. Returning the station number setting switch to the previous setting eliminates the error five seconds later and the ERR. LED turns off.
- Do not set a same station number as another station number. If a duplicate station number is used, a communication error occurs and the D LINK LED does not turn on.

## Tightening torque

Tighten the screw for the station number setting switch cover within the following tightening torque range.

Screw type	Tightening torque range
Station number setting switch cover (M3 screw)	0.43 to 0.57N·m

### Point

- Do not put oil on the screw. Failure to do so may damage the screw.
- Tighten the screw with an applicable screwdriver. Tightening it with an inapplicable screwdriver may damage the screw.

## 6.2 Installation Environment and Installation Position

### Installation environment

#### Installation location

Do not install the safety remote I/O module to a place where:

- Ambient temperature is outside the range of 0 to 55°C;
- IP67 is not satisfied;
- Condensation occurs due to rapid temperature change;
- Corrosive gas or combustible gas is present;
- Conductive powder such as iron powder, oil mist, salinity, or organic solvent is filled;
- The safety remote I/O module is exposed to direct sunlight;
- A strong electric field or strong magnetic field is generated; and
- The safety remote I/O module is subject to vibration and shock.

#### Installation surface

Install the safety remote I/O module on a flat surface. When the installation surface is uneven, excessive force is applied to the printed-circuit board and may cause a defect.

## Installation position

When installing the safety remote I/O module, provide a clearance between the module and the sides of neighboring structures or parts to ensure good ventilation, avoid interference, and avoid stress on waterproof connectors.

To insert or remove a communication connector, provide a clearance sufficient to use a screwdriver.

When using a right-angle, waterproof connector or a Y branch connector, provide a clearance to avoid stress on cables.

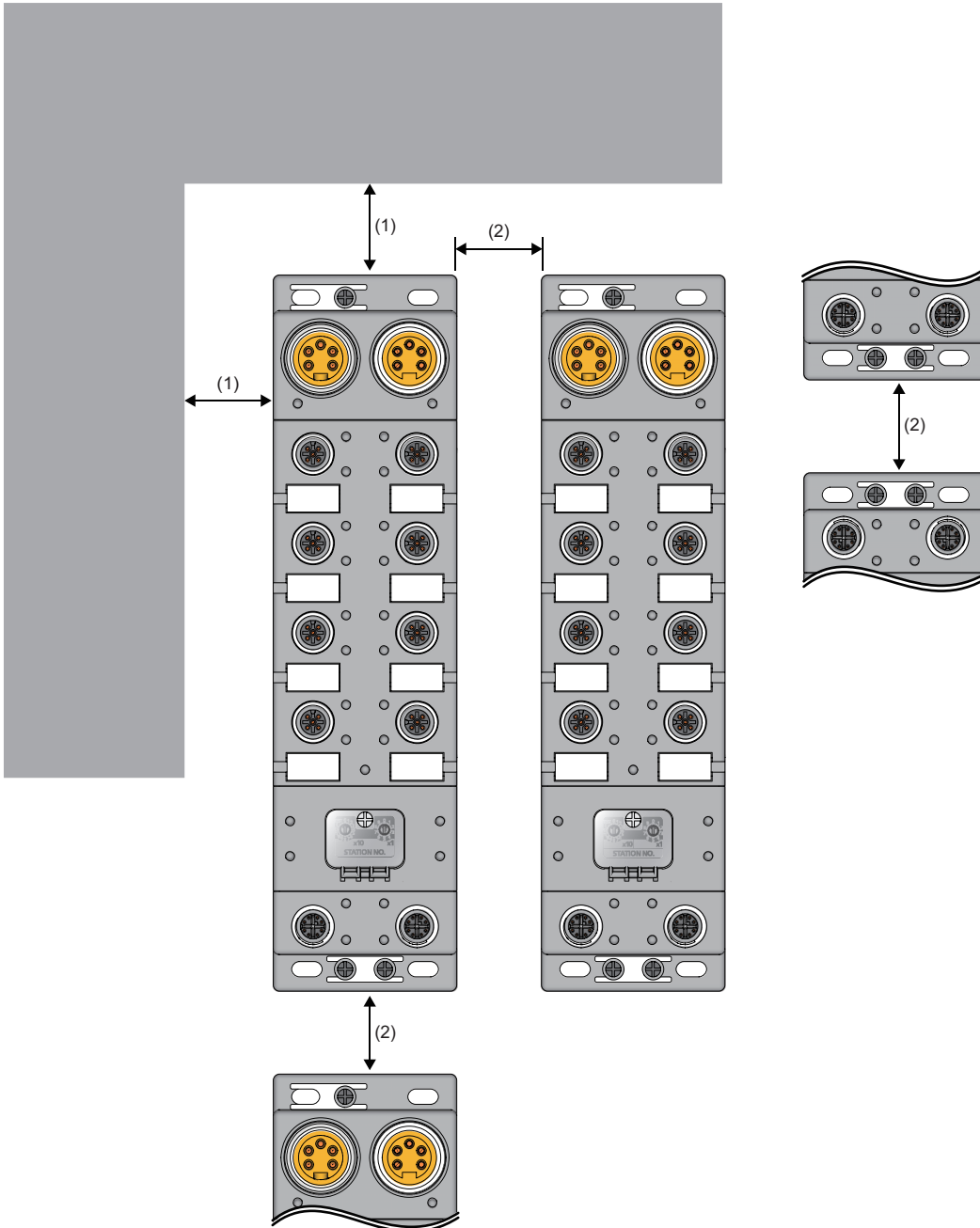

- (1) 0mm or longer
- (2) 50mm or longer

## Installation direction

The safety remote I/O module can be installed in six directions.

Fix the module with screws.



## 6.3 Installation

### Fixing the safety remote I/O module

When fixing the safety remote I/O module, tighten all of four screws.

Otherwise, the module will be greatly affected by vibration, causing failure of the module.

When installing the module, tighten screws within the following torque range.

Screw type	Tightening torque range
Module mounting screw (M4 screw)	0.824 to 1.11N·m
Screw for an FG metal fitting (M3 screw)	0.425 to 0.575N·m

#### Point

- Do not put oil on the screw. Failure to do so may damage the screw.
- Tighten the screw with an applicable screwdriver. Tightening it with an inapplicable screwdriver may damage the screw.

# 6.4 Wiring

## Wiring the power supply

When wiring the power supply, connect it to the POWER IN terminal of the power supply connector of the safety remote I/O module.

### Transition wiring of the power supply

When installing multiple safety remote I/O modules, the power can be supplied to the modules through transition wiring. For transition wiring, connect wires between the POWER OUT terminal of the safety remote I/O module that will be the power supplier and the POWER IN terminal of another safety remote I/O module that will be a power supply destination.

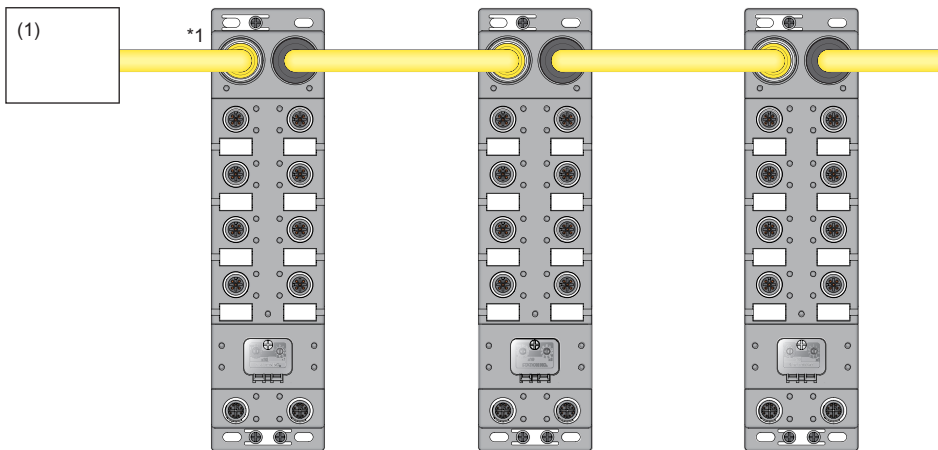

\*1 The largest current flows from the power supplier to the power supply connector of the first safety remote I/O module. Make sure that the current does not exceed the current capacity (8A/pin) of the power supply connector. For a power supply to supply 24VDC, use a power supply (SELV power supply) that does not exceed 30VAC (effective value), 42.4V (peak value), or 60VDC. Also, use a power supply which is applied to "limited-energy circuit" defined in IEC61010-1.

(1) Power supply



For transition wiring, check the current consumption of each of the wired safety remote I/O modules.

For the current consumption of a safety remote I/O module, refer to the following.

➔ Page 20 Performance Specifications

# Wiring of Ethernet cable

## Connecting the Ethernet cable

### ■Connecting

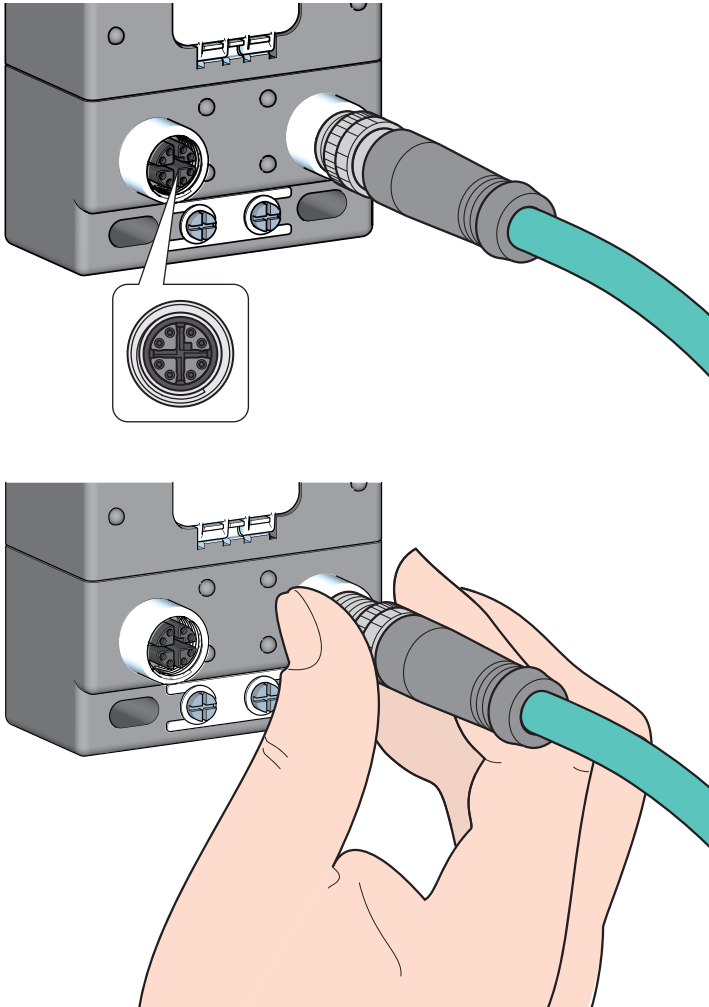

1. Power off the module power supply of the safety remote I/O module and the power supply of the external device.
2. Push the Ethernet cable connector into the safety remote I/O module, paying attention to the connector's direction.

3. Tighten the screw of the Ethernet cable.

4. Power on the module power supply.
5. Power on the power supply of the external device.
6. Check that the LINK LED on the port into which the Ethernet cable is connected is on.\*1

\*1 The time taken for the LINK LED to turn on after connection of the cable may vary. The LINK LED normally turns on in a few second. However, if link-up processing is repeated due to a condition of a device on the line, the longer time may be required. If the LINK LED does not turn on, refer to the following and take a corrective action.

☞ Page 82 When the LINK LED turns off

- PORT1 and PORT2 need not be distinguished. When only one connector is used in star topology, either PORT1 or PORT2 can be connected.
- When two connectors are used in line topology or ring topology, an Ethernet cable can be connected to the connectors in any combination. For example, the cable can be connected between PORT1s and between PORT1 and PORT2.
- Connection between PORT1 and PORT1 or between PORT2 and PORT2

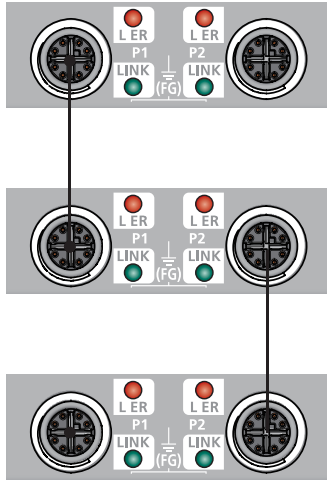

- Connection between PORT1 and PORT2

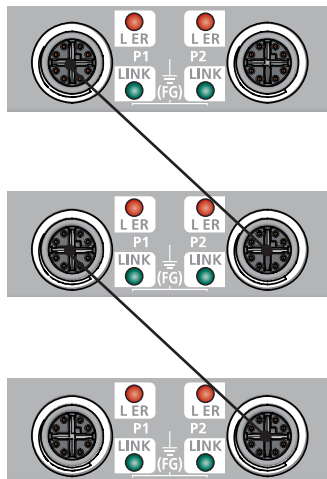

## ■ Disconnecting

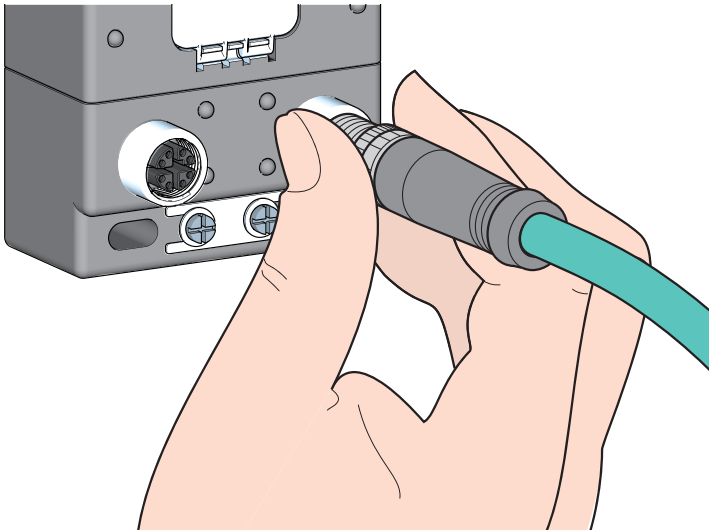

1. Power off the module power supply.
2. Loosen the screw of the Ethernet cable and remove the Ethernet cable.

## Precautions

### ■ Laying Ethernet cables

- Place the Ethernet cables in a duct or clamp them. If not, dangling cable may swing or inadvertently be pulled, resulting in damage to the module or cables or malfunction due to poor contact.
- Do not touch the core of the connector of the cable or the module, and protect it from dirt and dust. If any oil from your hand, or any dirt or dust sticks to the core, it can increase transmission loss, causing data link to fail.
- Check that any Ethernet cable is not disconnected or shorted, or that the connectors are securely connected.

### ■ Connecting and disconnecting the Ethernet cable

Hold the connector part when connecting and disconnecting the Ethernet cable. Pulling the cable connected to the module may result in damage to the module or cable or malfunction due to poor contact.

### ■ Connectors without Ethernet cable

To prevent dust from entering the module, attach the provided waterproof caps.

### ■ Maximum station-to-station distance (Maximum Ethernet cable length)

The maximum station-to-station distance is 100m. However, the distance may be shorter depending on the operating environment of the cable. For details, contact the manufacturer of the cables used.

### ■ Bending radius of the Ethernet cable

There are restrictions on the bending radius of the Ethernet cable. Check the bending radius in the specifications of the Ethernet cables used.

## Attaching waterproof caps

Tighten the waterproof caps within the following torque range.

Screw type	Tightening torque range
Waterproof cap	0.30 to 0.34N·m

## Precautions for wiring the safety remote I/O module to safety devices



---

This section describes the precautions for the wiring. To wire the safety remote I/O module to each safety device according to Category 4, perform both of the following for the safety remote I/O module.

- Double wiring inputs
  - ☞ Page 45 Double wiring function
- Double wiring outputs
  - ☞ Page 50 Double wiring function
- Executing the self-diagnostic function (dark test)
  - ☞ Page 55 Input dark test function
  - ☞ Page 57 Output dark test function

# 7 FUNCTIONS

This chapter describes the functions available in the safety remote I/O module, and the setting procedures for those functions. For details on safety remote I/O signals, remote I/O signals, and remote buffer memory, refer to the following.

- Safety remote I/O signals (  Page 104 Safety Remote I/O Signals)
- Remote I/O signals (  Page 108 Remote I/O Signals)
- Remote buffer memory (  Page 113 Remote Buffer Memory)

## 7.1 Input Function

This function safely inputs external signals. This function cannot be used in any modes other than the safety drive mode. All the safety remote inputs (SAIX) are off in any modes other than the safety drive mode.

### Input wiring selection function

This function selects double wiring or single wiring of the input wiring.

#### Double wiring function

The double wiring function supports double input wiring.

By verifying input signals of double wiring, safety inputs can be turned off even though one of the signals has an error.

The following two are the double wiring methods for safety remote input (SAIX).

- Double wiring example for input (NC/NC)

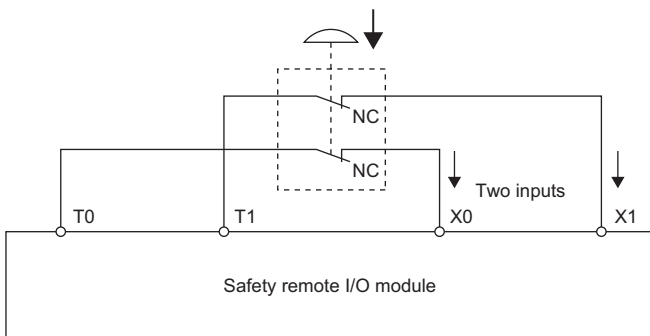

- Double wiring example for input (NC/NO)

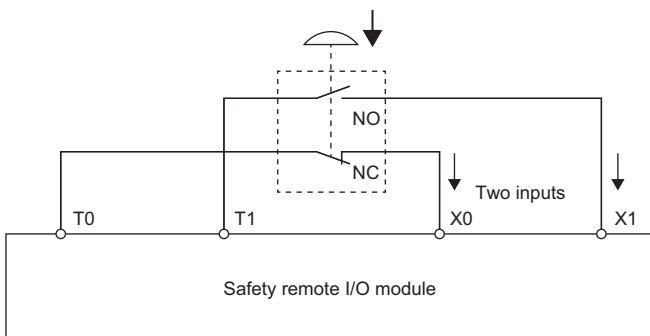

## ■Combination for double wiring

Use the following combinations of input terminals for double wiring to the safety remote I/O module.

Combination of input terminals					
X0, X1	X2, X3	X4, X5	X6, X7	X8, X9	XA, XB

The following table lists the relation of input terminals (X) and safety remote inputs (SAIX).

Safety remote input (SAIX)	Input terminal (X)
SAIX0	X0
SAIX1	X1
to	to
SAIXA	XA
SAIXB	XB

## Single wiring function

This function can connect input devices with single wiring.

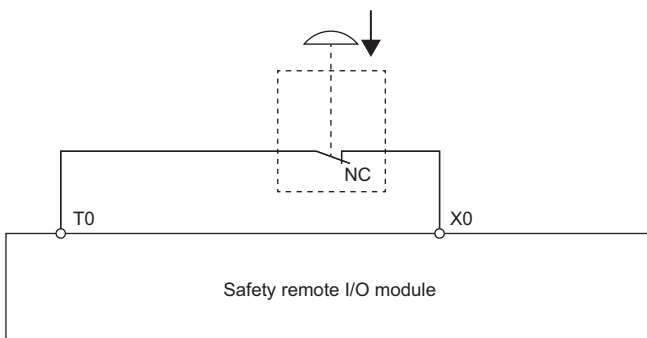

### Point

Connecting input devices with single wiring brings the safety category to SIL2/CAT2 PLd.

## Diagnostic functions to detect input errors

Input errors can be detected by using the following diagnostic functions.

Diagnostic function	Description	Reference
Double input discrepancy detection function	Detects the discrepancy of double input signals.	☞ Page 53 Double input discrepancy detection function
Input dark test function	Outputs test pulses to turn off the external input signals (X0 to XB) that are on for a short time and diagnoses contacts including external devices for failure.	☞ Page 55 Input dark test function



## Combination of double inputs

The safety remote I/O module evaluates the logic of input signals and reflects the results to safety remote inputs (SAIX). When the double input signals differ, the double input discrepancy detection state is applied. The following tables list the correspondence between each double input signal state and safety remote input (SAIX).

### ■Combination of double inputs (NC/NC)

Input terminal state		Safety remote input (SAIX0 to SAIXB)		Safety input status (SAIXC to SAIX17)		I/O LED status		Evaluation result of double inputs
Xn <sup>*1</sup>	Xn+1 <sup>*1</sup>	SAIXm <sup>*2</sup>	SAIXm+1 <sup>*2</sup>	SAIXC+m <sup>*2</sup>	SAIXC+m+1 <sup>*2</sup>	Xn <sup>*1</sup>	Xn+1 <sup>*1</sup>	
OFF	OFF	OFF	OFF	ON	ON	Off	Off	OFF (Normal)
OFF	ON	OFF	OFF	OFF <sup>*3</sup>	OFF <sup>*3</sup>	Red <sup>*3</sup>	Red <sup>*3</sup>	OFF (Discrepancy)
ON	OFF	OFF	OFF	OFF <sup>*3</sup>	OFF <sup>*3</sup>	Red <sup>*3</sup>	Red <sup>*3</sup>	OFF (Discrepancy)
ON	ON	ON	ON	ON	ON	Green	Green	ON (Normal)

\*1 n: Even number from 0 to A

\*2 m: Safety device address (even number from 0 to A) assigned to the master station

\*3 After the double input discrepancy time has elapsed, the status changes to the listed status.

### ■Combination of double inputs (NC/NO)

Input terminal state		Safety remote input (SAIX0 to SAIXB)		Safety input status (SAIXC to SAIX17)		I/O LED status		Evaluation result of double inputs
Xn <sup>*1</sup>	Xn+1 <sup>*1</sup>	SAIXm <sup>*2</sup>	SAIXm+1 <sup>*2</sup>	SAIXC+m <sup>*2</sup>	SAIXC+m+1 <sup>*2</sup>	Xn <sup>*1</sup>	Xn+1 <sup>*1</sup>	
OFF	OFF	OFF	ON	OFF	OFF	Red <sup>*3</sup>	Red <sup>*3</sup>	OFF (Discrepancy)
OFF	ON	OFF	ON	ON	ON	Off	Green	OFF (Normal)
ON	OFF	ON	OFF	ON	ON	Green	Off	ON (Normal)
ON	ON	OFF	ON	OFF	OFF	Red <sup>*3</sup>	Red <sup>*3</sup>	ON (Discrepancy)

\*1 n: Even number from 0 to A

\*2 m: Safety device address (even number from 0 to A) assigned to the master station

\*3 After the double input discrepancy time has elapsed, the status changes to the listed status.

### ■States of safety remote inputs (SAIX0, SAIX1) for X0 and X1 (double wiring (NC/NC))

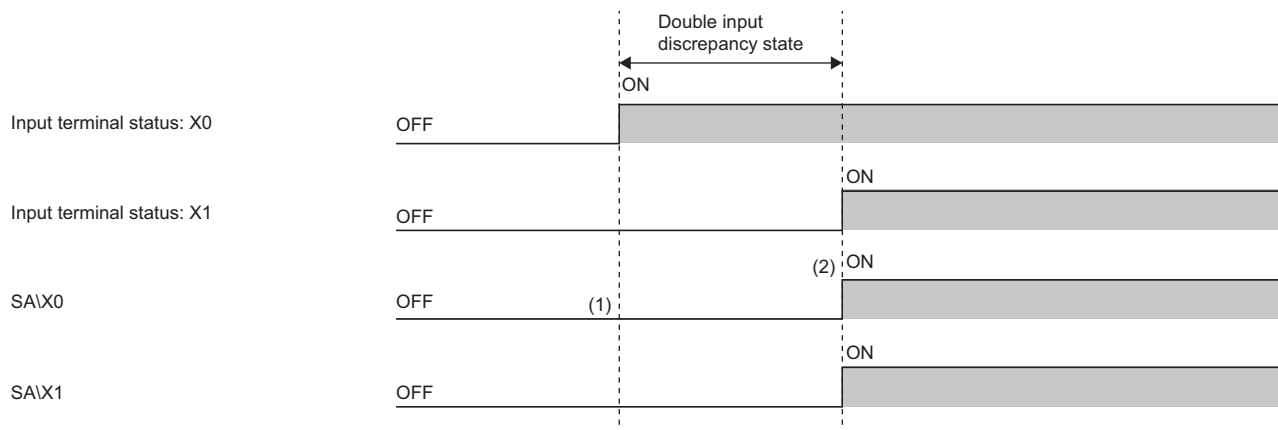

(1) Even when the input terminal X0 turns on, SAIX0 does not turn on because X1 is off.

(2) When the double inputs are on (X0 and X1 are on), SAIX0 and SAIX1 turn on.

Even when SAIX0 and SAIX1 are off, the time when X0 and X1 are in double input discrepancy state is measured and if the measured time exceeds a set detection time, a double input discrepancy detection error occurs.

## ■ States of safety remote inputs (SA\X0, SA\X1) for X0 and X1 (double wiring (NC/NO))

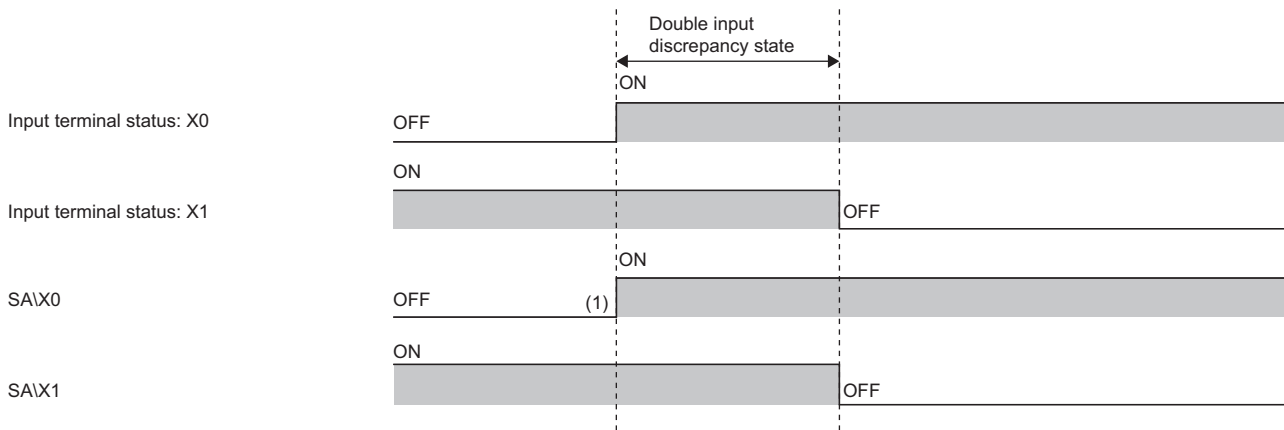

(1) The same value as the input terminal is reflected.

Even when SA\X0 and SA\X1 are off, the time when X0 and X1 are in double input discrepancy state is measured and if the measured time exceeds a set detection time, a double input discrepancy detection error occurs.

## Setting procedure

Set the input wiring selection in "Wiring selection of input" from the "Parameter Processing of Slave Station" window of the engineering tool.

For the procedure to display the "Parameter Processing of Slave Station" window, refer to the following.

Page 67 Module parameter setting procedure

Item	Setting range
Wiring selection of input X0/X1 to XA/XB	1: Double wiring (NC/NC) (default) 2: Double wiring (NC/NO) 3: Single wiring

### Point

When "Wiring selection of input" is set to "3: Single wiring", both X<sub>n</sub> and X<sub>n+1</sub> are single wiring.

## External input signal monitor function

The state of input terminals can be monitored. This function facilitates the investigation for the cause of a double input discrepancy error. For details, refer to the following.

Page 111 External input monitor (RX30 to RX3F)

### Point

External input monitors (RX30 to RX3F) are the remote control/monitor signals to investigate the cause of a double input discrepancy error. Do not use them in a safety program.

## Input ON delay, input OFF delay functions

This function changes an input signal when a predetermined time has passed after an actual input change. A delay time can be set for each input change pattern, OFF to ON or ON to OFF. In addition, the function prevents incorrect inputs caused by noise since a pulse of a certain time length is not taken in a module.

### Input ON delay

The ON delay is the minimum ON time of the actual input signal required before the safety input signal changes from OFF to ON.

**Ex.**

When 5ms is set, the safety input signal turns to ON after the actual input signal is ON for at least 5ms.

### Input OFF delay

The OFF delay is the minimum OFF time of the actual input signal required before the safety input signal changes from ON to OFF.

**Ex.**

When 5ms is set, the safety input signal turns to OFF after the actual input signal is OFF for at least 5ms.

### Setting procedure

The "Input ON delay" and "Input OFF delay" times can be set from the "Parameter Processing of Slave Station" window of the engineering tool.

The setting range is 0 to 1000ms (in 1ms steps)

The default value is 5ms.

#### **Point**

- When "Wiring selection of input" is set to "1: Double wiring (NC/NC)" or "2: Double wiring (NC/NO)", set the same value as  $X_{n+1}$  for  $X_n$  ( $n$ : even number).
- When "Input mode setting" is set to "1: Not used", this parameter will be ignored.
- In addition to this setting value, the safety refresh response processing time and the hardware response time are also added as delay time for safety input signal switching. (Safety refresh response processing time: 10ms, hardware response time: OFF→ON (0.5ms), ON→OFF (1.5ms))

# 7.2 Output Function

This function safely outputs signals. This function cannot be used in any modes other than the safety drive mode. All the safety remote outputs (SA\Y) are off in any modes other than the safety drive mode.

## Output wiring selection function

This function selects double wiring or single wiring of the output wiring.

### Double wiring function

The double wiring function supports double outputs. By multiplying output signals using double wiring, safety outputs can be turned off even though one of the signals has an error.

The following two are the double wiring methods for safety remote output (SA\Y).

#### ■Double wiring for output (source + source connection)

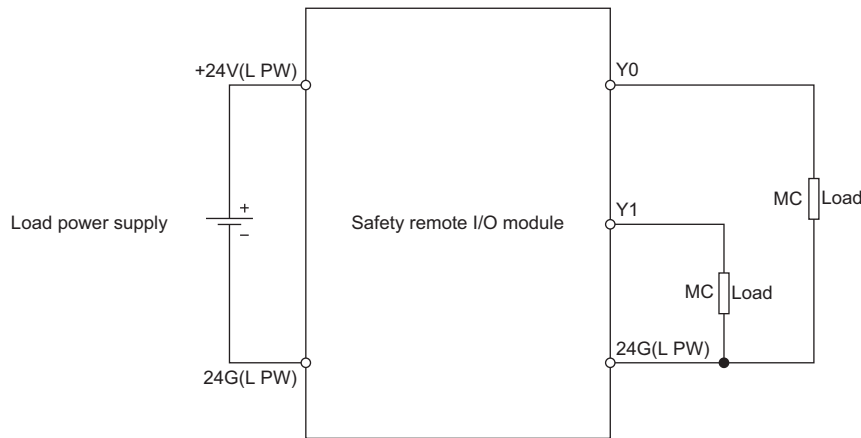

#### ■Double wiring for output (source + sink connection)

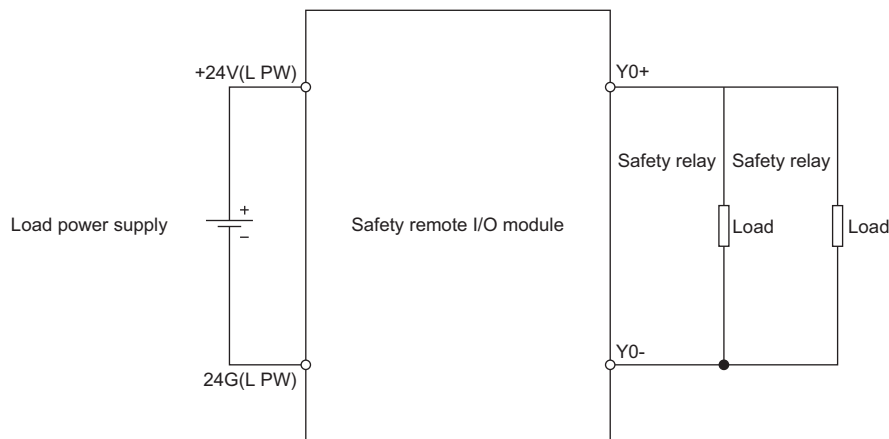

#### ■Combination for double wiring

Use the following combinations of output terminals for double wiring to the safety remote I/O module.

Combination of output terminals			
Double wiring (source + source connection)		Double wiring (source + sink connection)	
Y0, Y1	Y2, Y3	Y0+, Y0-	Y1+, Y1-

## Single wiring function (NZ2GFS12A2-16DTE)

This function can connect output devices with single wiring.

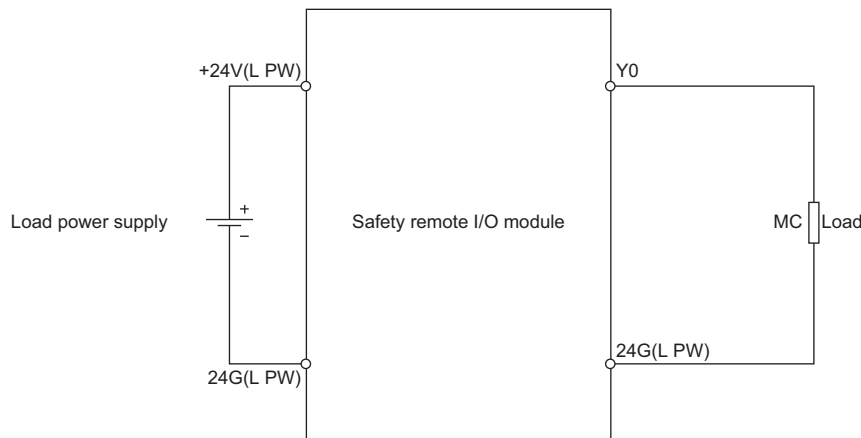

Connecting output devices with single wiring brings the safety category to SIL2/CAT2 PLd.

## Diagnostic functions to detect output errors

Output errors can be detected by using the following diagnostic functions.

Diagnostic function	Description	Reference
Output dark test function	Outputs test pulses to turn off the outputs that are on for a short time and diagnoses the internal circuit for failure.	Page 57 Output dark test function
Output read-back function	Reads back output results and diagnoses whether the outputs are correctly on or off.	Page 59 Output read-back function

## Combination of double outputs

Both terminals of double outputs are turned on only when both safety remote outputs (SA\Y) are on. The safety remote I/O module evaluates the logic of safety remote outputs (SA\Y) and determines the state of the output terminals. The following tables list the correspondence between each state of safety remote output (SA\Y) and output terminal for double outputs.

### ■Combination of double outputs (source + source connection)

Safety remote output (SA\Y0 to SA\Y3)		Output terminal state		Safety output status (SA\X18 to SA\X1B)		I/O LED status	
SA\Y <sup>*1</sup>	SA\Y <sub>m+1</sub> <sup>*1</sup>	Y <sub>n</sub> <sup>*2</sup>	Y <sub>n+1</sub> <sup>*2</sup>	SA\X <sub>18+m</sub> <sup>*1</sup>	SA\X <sub>18+m+1</sub> <sup>*1</sup>	Y <sub>n</sub> <sup>*2</sup>	Y <sub>n+1</sub> <sup>*2</sup>
OFF	OFF	OFF	OFF	ON	ON	Off	Off
OFF	ON	OFF	OFF	OFF	OFF	Red	Red
ON	OFF	OFF	OFF	OFF	OFF	Red	Red
ON	ON	ON	ON	ON	ON	Green	Green

\*1 m: Safety device address (even number from 0 to 3) assigned to the master station

\*2 n: Even number from 0 to 3

## ■Combination of double outputs (source + sink connection)

Safety remote output (SAI\Y0 to SAI\Y3)		Output terminal state		Safety output status (SAI\X18 to SAI\X1B)		I/O LED status	
SAI\Ym <sup>*1</sup>	SAI\Ym+1 <sup>*1</sup>	Yp <sup>+*2</sup>	Yp <sup>-*2</sup>	SAI\X18+m <sup>*1</sup>	SAI\X18+m+1 <sup>*1</sup>	Yp <sup>+*2</sup>	Yp <sup>-*2</sup>
OFF	OFF	OFF	OFF	ON	ON	Off	Off
OFF	ON	OFF	OFF	OFF	OFF	Red	Red
ON	OFF	OFF	OFF	OFF	OFF	Red	Red
ON	ON	ON	ON	ON	ON	Green	Green

\*1 m: Safety device address (even number from 0 to 1) assigned to the master station

\*2 p: 0, 1

## ■States of safety remote outputs (SAI\Y0, SAI\Y1) for Y0 and Y1 (double wiring (source + source connection))

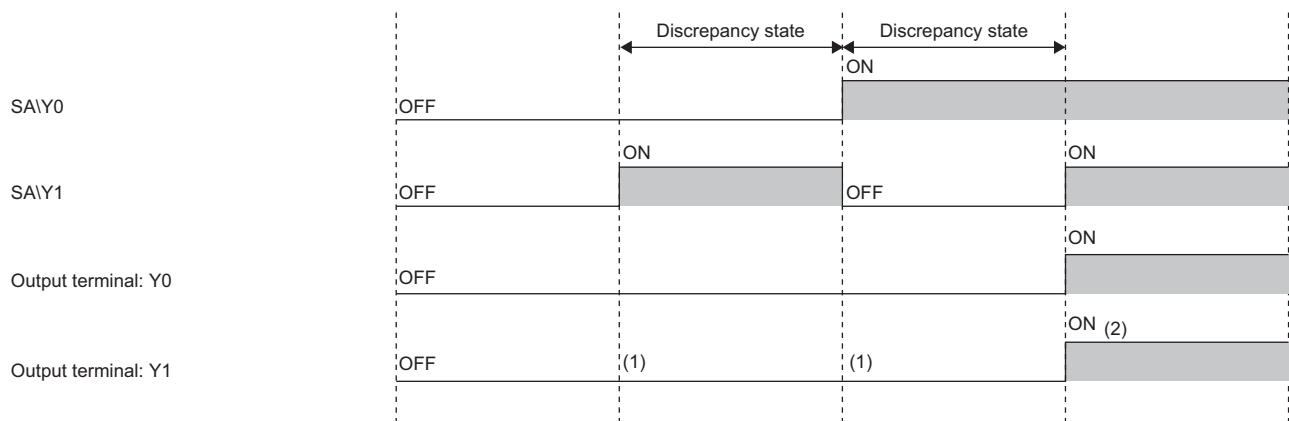

(1) When double outputs (source + source) are in the discrepancy state (SAI\Y0 and SAI\Y1 are different), Y0 and Y1 are off.

(2) When double outputs (source + source) are on (SAI\Y0 and SAI\Y1 are on), Y0 and Y1 are on.



If double outputs are in discrepancy state, a minor error (0207H: I/O data error) occurs.

## Setting procedure

Set the output wiring selection in "Wiring selection of output" from the "Parameter Processing of Slave Station" window of the engineering tool.

For the procedure to display the "Parameter Processing of Slave Station" window, refer to the following.

☞ Page 67 Module parameter setting procedure

## ■Wiring selection of output (NZ2GFS12A2-16DTE)

Item	Setting range
Wiring selection of output Yn/Yn+1 (n: 0, 2)	1: Double wiring (default) 2: Single wiring

## ■Wiring selection of output (NZ2GFS12A2-14DT)

Item	Setting range
Wiring selection of output Yn (n: 0, 1)	1: Double wiring (default)



When "Wiring selection of output" is set to "2: Single wiring", both Yn and Yn+1 are single wiring.

# 7.3 Input Diagnostic Function

## Double input discrepancy detection function

This function discriminates failures by monitoring the discrepancy state of doubled safety remote inputs (SAIX). When the discrepancy state is detected, a minor error occurs. The module will recover from the error by eliminating its cause.

### Double input discrepancy detection

When the discrepancy state of double inputs continues for the set time or longer, a double input discrepancy detection error occurs as an input error. For the double input discrepancy detection time, refer to the following.

☞ Page 54 Double input discrepancy detection time

The following shows the operation details of the double input discrepancy detection for double wiring inputs (NC/NC connection), X0 and X1.

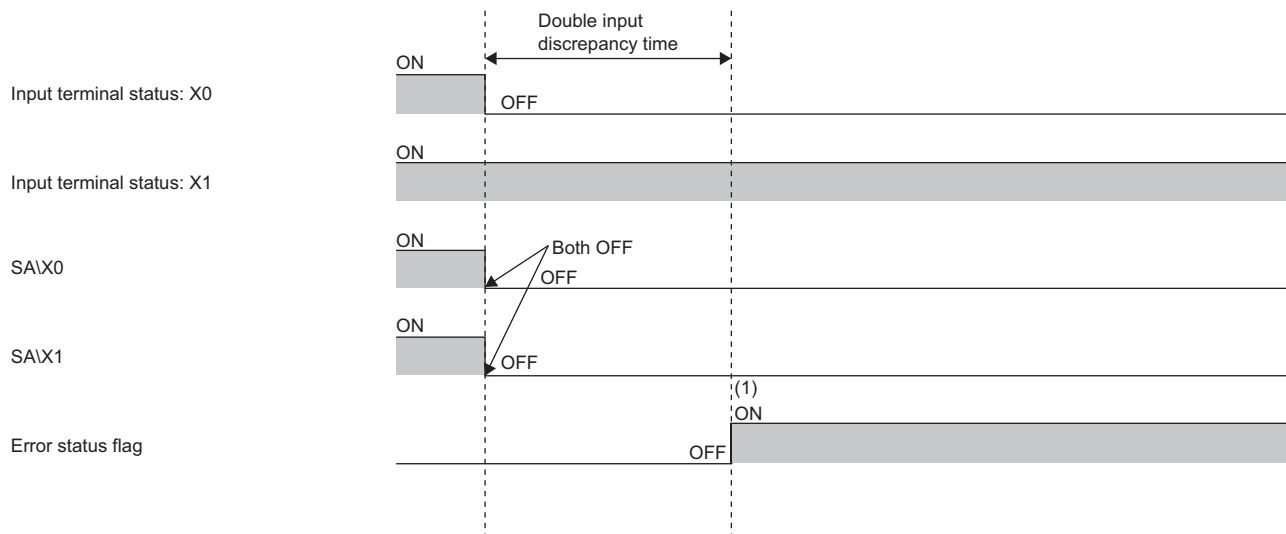

(1) After the double input discrepancy detection time elapses, a double input discrepancy detection error occurs.

### ■ Operation at error detection

When the discrepancy state of double inputs continues for the set time or longer, the minor error (double input discrepancy detection error) state is applied to the safety remote I/O module. For the minor error state, refer to the following.

☞ Page 95 Error Code List

The corresponding input points are turned off when the discrepancy state of inputs occurs.

## Double input discrepancy detection time

Even if double input discrepancy is detected, an error does not occur during the set detection time. The logic of input signals is evaluated and is reflected to the safety remote inputs (SAIX).

The following tables list the relation of each double input evaluation result and the double input discrepancy detection time. The relation varies depending on a combination of double inputs.

### ■Combination of double inputs (NC/NC)

Input terminal state		Time passed after the discrepancy state is applied	Safety remote input		Evaluation result of double inputs
Xn <sup>*1</sup>	Xn+1 <sup>*1</sup>		SAIXm <sup>*2</sup>	SAIXm+1 <sup>*2</sup>	
OFF	OFF	—	OFF	OFF	OFF (Normal)
OFF	ON	< Double input discrepancy detection time	OFF	OFF	OFF (Discrepancy) <sup>*3</sup>
OFF	ON	≥ Double input discrepancy detection time	OFF	OFF	Double input discrepancy detection error
ON	OFF	< Double input discrepancy detection time	OFF	OFF	OFF (Discrepancy) <sup>*3</sup>
ON	OFF	≥ Double input discrepancy detection time	OFF	OFF	Double input discrepancy detection error
ON	ON	—	ON	ON	ON (Normal)

\*1 n: Even number from 0 to A

\*2 m: Safety device address (even number from 0 to A) assigned to the master station

\*3 When the double input discrepancy detection time has not elapsed, the input is OFF and the safety input status is ON.

### ■Combination of double inputs (NC/NO)

Input terminal state		Time passed after the discrepancy state is applied	Safety remote input		Evaluation result of double inputs
Xn <sup>*1</sup>	Xn+1 <sup>*1</sup>		SAIXm <sup>*2</sup>	SAIXm+1 <sup>*2</sup>	
OFF	OFF	< Double input discrepancy detection time	OFF	ON	OFF (Discrepancy) <sup>*3</sup>
OFF	OFF	≥ Double input discrepancy detection time	OFF	ON	Double input discrepancy detection error
OFF	ON	—	OFF	ON	OFF (Normal)
ON	OFF	—	ON	OFF	ON (Normal)
ON	ON	< Double input discrepancy detection time	OFF	ON	OFF (Discrepancy) <sup>*3</sup>
ON	ON	≥ Double input discrepancy detection time	OFF	ON	Double input discrepancy detection error

\*1 n: Even number from 0 to A

\*2 m: Safety device address (even number from 0 to A) assigned to the master station

\*3 When the double input discrepancy detection time has not elapsed, the input is OFF and the safety input status is ON.

## Setting procedure

Set the double input discrepancy detection time in "Double input discrepancy detection time" from the "Parameter Processing of Slave Station" window of the engineering tool.

For the procedure to display the "Parameter Processing of Slave Station" window, refer to the following.

 Page 67 Module parameter setting procedure



## Double input discrepancy detection time

Item	Setting range
Double input discrepancy detection time Xn/Xn+1 (n: even number from 0 to A)	10 to 30000 (ms) (default value: 10)

### Point

- A double input discrepancy error is detected in signals after the input response time has passed. Therefore, the time taken from when actual signals are in the discrepancy state until when a double input discrepancy detection error occurs is equal to the input ON delay, input OFF delay time + double input discrepancy detection time.
- Set the double input discrepancy detection time based on the following values: 100ms for mechanical switches and 20ms for sensor inputs.

## Input dark test function

This function outputs test pulses to turn off the external input signals (X0 to XB) that are on for a short time and diagnoses contacts including external devices for failure.

When failure is detected, a minor error occurs. The module will recover from the error by eliminating its cause.

To use this function, settings of "Input mode setting" and "Input test pulse setting" are required.

The function detects internal circuit fixing, a short circuit caused by another safety input in one M12 connector as well as a short circuit on 24G in the same M12 connector, on the condition that contacts of external devices are closed.

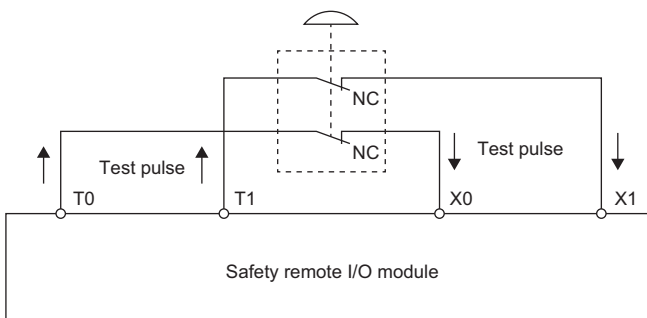

To use the input dark test function, use the test pulse output terminals (T0 to TB) and connect input devices.

To use the input dark test function, use the input terminals and test pulse output terminals (T0 to TB) of the safety remote I/O module in the following combinations. An incorrect combination is regarded as a disconnection, and a minor error (input dark test error) may occur.

The input dark test function can be used only when "Input mode setting" is set to "2: Input dark test execution".

Test pulse output terminal	Input terminal	Test pulse output terminal	Input terminal
T0	X0	T6	X6
T1	X1	T7	X7
T2	X2	T8	X8
T3	X3	T9	X9
T4	X4	TA	XA
T5	X5	TB	XB

### Point

The test pulse is output every 100ms, and the pulse width is fixed at 2ms.

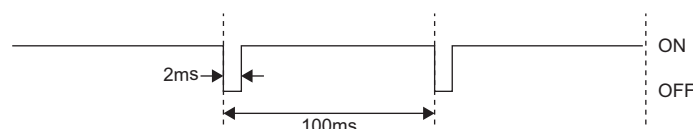

## Operation at error detection

When an error is detected in a diagnostic of the input dark test function, the minor error (input dark test error) state is applied. For details on the minor error state, refer to the following.

 Page 95 Error Code List

## Setting procedure

### ■ Input mode setting

Set whether to perform the input dark test function or not in "Input mode setting" from the "Parameter Processing of Slave Station" window of the engineering tool.

For the procedure to display the "Parameter Processing of Slave Station" window, refer to the following.

 Page 67 Module parameter setting procedure

Item	Setting range
Input mode setting X0 to XB	1: Not used (default) 2: Input dark test execution 3: Input dark test non-execution

### Point

- When "Input mode setting" is set to "1: Not used", the input value is always 0, and the safety input status is always ON.
- When "Input mode setting" is set to "2: Input dark test execution", set "Input test pulse setting" to "1: With test pulse".

### ■ Input test pulse setting

To perform the input dark test function, set "Input test pulse setting" from the "Parameter Processing of Slave Station" window of the engineering tool.

For the procedure to display the "Parameter Processing of Slave Station" window, refer to the following.

 Page 67 Module parameter setting procedure

Item	Setting range
Input test pulse setting X0 to XB	1: With test pulse 2: Without test pulse (default)

# 7.4 Output Diagnostic Function

## Output dark test function

This function outputs test pulses to turn off the external output signals (NZ2GFS12A2-16DTE: Y0 to Y3, NZ2GFS12A2-14DT: Y0 to Y1) that are on for a short time and diagnoses the internal circuit for failure.

When failure is detected, a minor error occurs. The module will recover from the error by eliminating its cause.

For NZ2GF12A2-16DTE, the following can be detected: Internal circuit fixing, a short circuit on the power supply caused by an external output signal, and a short circuit caused by another safety output in one M12 connector.

For NZ2GF12A2-14DT, the following can be detected: Internal circuit fixing, a short circuit on +24V caused by a source output signal, a short circuit on 24G caused by a sink output signal, and disconnection of an output signal.

In addition, the OFF time for test pulses can be set depending on the usage environment.

- NZ2GFS12A2-16DTE

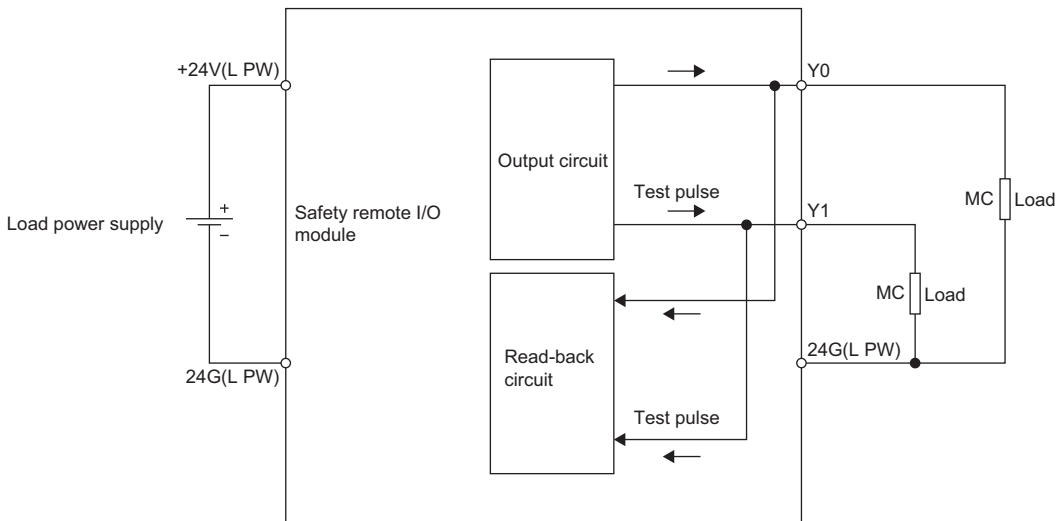

- NZ2GFS12A2-14DT

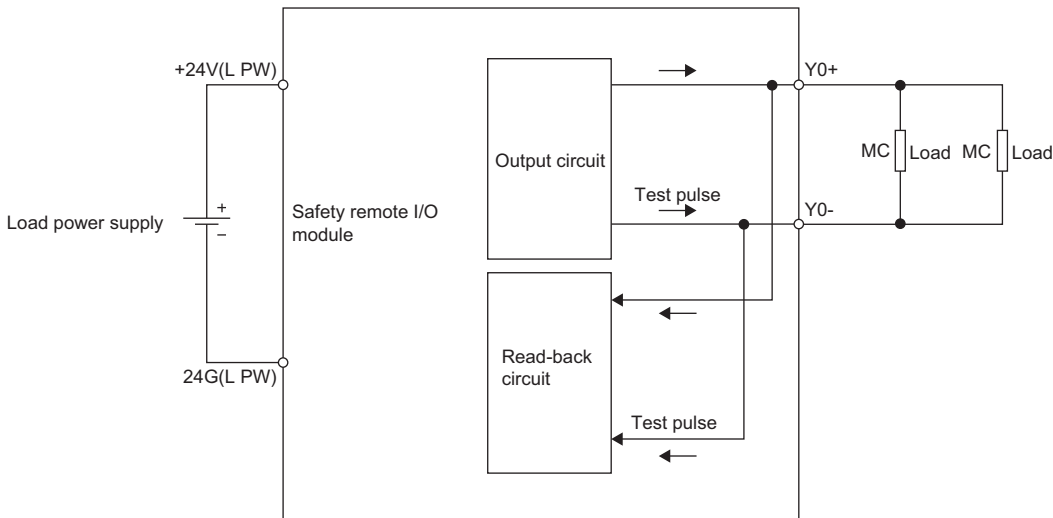

Depending on a timing, the output dark test pulse width may be shorter than the time set in "Output dark test pulse time".

## Operation at error detection

When the module detects an error in a diagnostic of the output dark test function, the minor error (output dark test error) state is applied and all output points are turned off. For details on the minor error state, refer to the following.

 Page 95 Error Code List

## Setting procedure

Set the following parameters for the output dark test function.

### ■Output mode setting

Set whether to perform the output dark test function or not in "Output mode setting" from the "Parameter Processing of Slave Station" window of the engineering tool.

For the procedure to display the "Parameter Processing of Slave Station" window, refer to the following.

 Page 67 Module parameter setting procedure

Model	Item	Setting range
NZ2GFS12A2-16DTE	Output mode setting Y0 to Y3	1: Not used (default)
NZ2GFS12A2-14DT	Output mode setting Y0+/Y0-/Y1+/Y1-	2: Output dark test execution 3: Output dark test non-execution

### Point

- For the NZ2GFS12A2-16DTE, when "Wiring selection of output" is set to "1: Double wiring", set the same value for both Y<sub>n</sub> and Y<sub>n+1</sub>.
- When "Output mode setting" is set to "1: Not used", the output value is always OFF.
- Set the same value to both "Output mode setting" (Y<sub>n</sub>) and "Output mode setting" (Y<sub>n+1</sub>) regardless of the setting of "Wiring selection of output" (Y<sub>n</sub>/Y<sub>n+1</sub>).

### ■Output dark test pulse time

Set the output dark test pulse time in "Output dark test pulse time" from the "Parameter Processing of Slave Station" window of the engineering tool.

For the procedure to display the "Parameter Processing of Slave Station" window, refer to the following.

 Page 67 Module parameter setting procedure

Model	Item	Setting range
NZ2GFS12A2-16DTE	Output dark test pulse time Y0 to Y3	3 to 100 (×100μs) (default value: 7)
NZ2GFS12A2-14DT	Output dark test pulse time Y0 to Y1	

### Point

- Adjust the output dark test pulse time depending on the installation environment or wiring length.
- For "Output dark test pulse time", using the default value is recommended because almost any applications can operate with "Output dark test pulse time" set to the default value.

# Output read-back function

This function reads back output results and diagnoses whether the external output signals (NZ2GFS12A2-16DTE: Y0 to Y3, NZ2GFS12A2-14DT: Y0 to Y1) are correctly output.

When an incorrect output is detected, a minor error occurs. The module will recover from the error by eliminating its cause. By diagnosing whether the status of output terminals matches with the output data of the safety device, this function detects output operation errors in the module. To use this function, setting parameters is not required.

- NZ2GFS12A2-16DTE

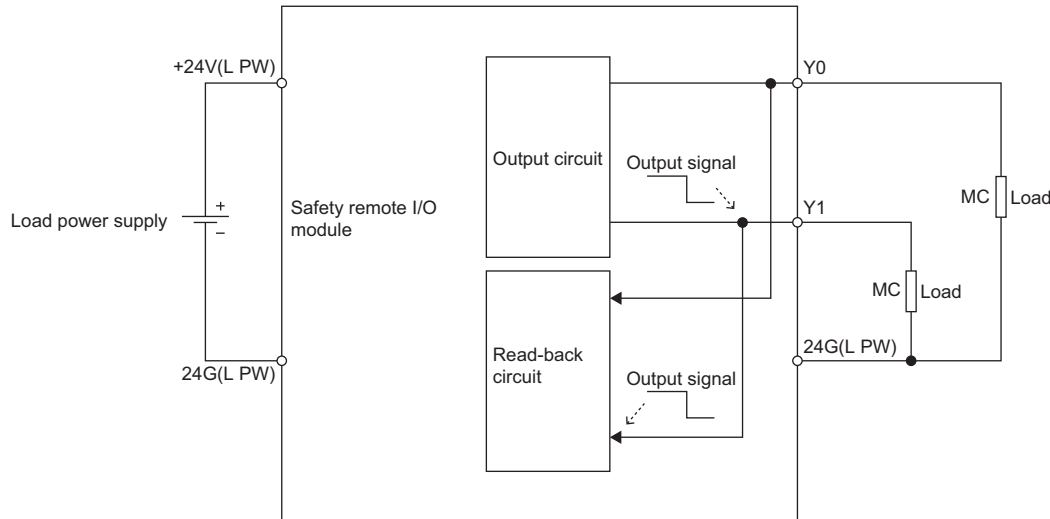

- NZ2GFS12A2-14DT

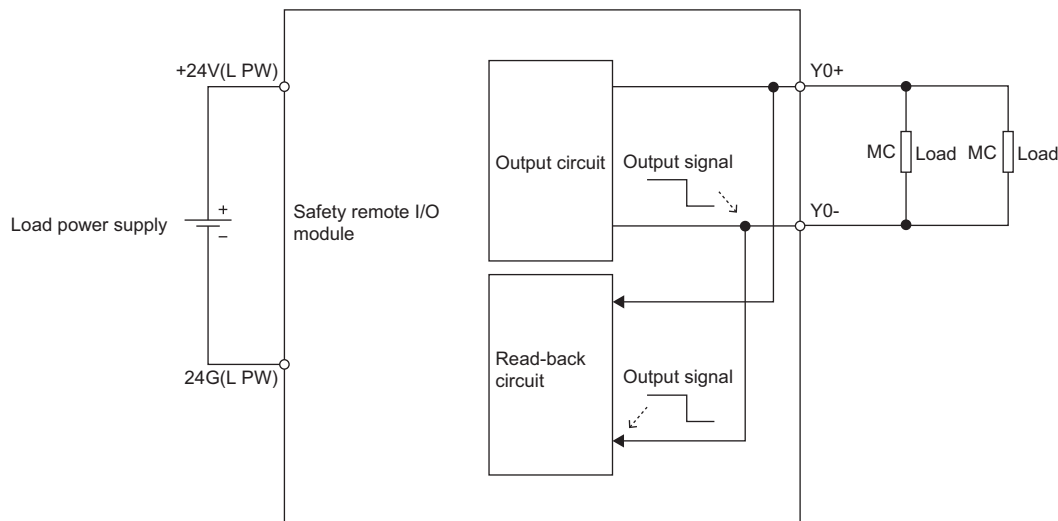

## Operation at error detection

When the safety remote I/O module detects an error in an output read-back function diagnostic, the minor error (output read-back error) state is applied and all output points are turned off. For details on the minor error state, refer to the following.

📖 Page 95 Error Code List

### Point

- When an error is detected in the input dark test and input internal dark test, the minor error state is applied to the module.
- The maximum output voltage in the output OFF state is 1.2V. However, even though the voltage exceeds 1.2V due to a short circuit or failure of the hardware, no error is detected until the voltage exceeds 7V. Thus, connected devices may turn on although the output of the module is in the OFF state.

# 7.5 User Authentication Function

This function limits the users who can access the Safety CPU or safety remote I/O module.

Using this function permits only the specified users to access the Safety CPU or safety remote I/O module.

This function is implemented in the Safety CPU used. For details on the user authentication function, refer to the following.

 MELSEC iQ-R CPU Module User's Manual (Application)

## Online operations that require user authentication

The following table lists the online operations that require user authentication. No limitation is applied to the access levels of the user authentication function. With any access level of "Administrators", "Developers", "AssistantDevelopers", and "Users", the operations can be performed after the user authentication.

Operation name	Necessity of user authentication	Online operation
"Parameter read"	Necessary*1	"Parameter Processing of Slave Station"
"Parameter write"	Necessary*1	
"Error history read"	Necessary*1	"Command Execution of Slave Station"
"Start of checking the module position"	Necessary	
"Stop of checking the module position"	Necessary	
"Error history clear request"	Necessary*1	
"Safety module validation"	Necessary	
"CC-Link IE Field Diagnostics"	Not necessary	"CC-Link IE Field Diagnostics"
"Remote Operation"	Not necessary	

\*1 To access the remote buffer memory using a program and perform the operations, the user authentication is not necessary.

## 7.6 Protection Functions

This function protects the internal circuit from overvoltage or overcurrent.

The following table lists protection functions.

○: Available, —: Not available

Function name	Purpose	Description	Target module	
			NZ2GFS12A2-16DTE	NZ2GFS12A2-14DT
Module power supply overvoltage protection	Prevents ignition or burnouts from/of the safety remote I/O module due to overvoltage on the module power supply.	This function operates when the module power supply is in the overvoltage state. After a voltage of 36VDC or higher applied for 2 seconds or longer activates the overvoltage protection, the safety state is ensured and thus the function is disabled.	○	○
Module power supply overcurrent protection	Prevents ignition or burnouts from/of the safety remote I/O module due to overcurrent on the module power supply.	This function operates when the module power supply is in the overcurrent state.	○	○
Load power supply overvoltage protection	Prevents ignition or burnouts from/of the safety remote I/O module and load circuits due to overvoltage on the load power supply.	This function operates when the load power supply is in the overvoltage state. After a voltage of 36VDC or higher applied for 2 seconds or longer activates the overvoltage protection, the safety state is ensured and thus the function is disabled.	○	○
Load power supply overcurrent protection	Prevents ignition or burnouts from/of the safety remote I/O module and load circuits due to overcurrent on the load power supply.	This function operates when the load power supply is in the overcurrent state.	○	○
Output overload/short circuit protection	Prevents ignition or burnouts from/of the safety remote I/O module due to overcurrent or overheat resulting from short-circuits of the output circuit.	This function operates when overcurrent flows. The safety remote I/O module recovers by eliminating the cause.	○	○

7

### Point

- The protection functions are intended to protect the internal circuit of a module, not to protect external devices.
- An overload may cause the internal temperature of the module to rise, resulting in deterioration in output elements and discoloration on the case and the printed-circuit board. When an abnormal load is found, turn off the corresponding output immediately and eliminate the cause.

# 8 PARAMETER SETTINGS

Configure the following parameter settings.

- Module parameter setting of the master station  
☞ Page 64 Module Parameter Setting of the Master Station
- Module parameter setting (safety remote I/O module)  
☞ Page 67 Module Parameter Setting

## Overview of the parameter setting procedure

The overview of the parameter setting procedure is shown below.

### 1. Preparation

Perform the following before parameter settings.

- Configure the system.
- Start the engineering tool.
- Set the Safety CPU to the TEST MODE.

For details on the TEST MODE of the Safety CPU, refer to the following.

📖 MELSEC iQ-R CPU Module User's Manual (Application)

### 2. Network Configuration Settings

Write the network configuration settings to the Safety CPU.

☞ Page 65 Module parameter setting procedure

### 3. Parameter Processing of Slave Station<sup>\*1</sup>

Perform the parameter processing of slave station.

☞ Page 67 Module parameter setting procedure

Step 1 to 7

### 4. Safety Communication Setting

Write the safety communication setting of the master station to the Safety CPU.

☞ Page 67 Module parameter setting procedure

Step 8 to 12

### 5. Checking the position of the setting target module<sup>\*1</sup>

Perform the checking of the position of the safety remote I/O module where the parameters are set.

☞ Page 67 Module parameter setting procedure

Step 13 to 18

### 6. Safety module validation<sup>\*1</sup>

Switch the safety remote I/O module to the state where safety communications are enabled (safety drive mode).

☞ Page 67 Module parameter setting procedure

Step 19 to 23

<sup>\*1</sup> Perform the operations to all safety remote I/O modules connected.



- 
- Write the safety communication setting to the Safety CPU after completing "Parameter write" to all safety remote I/O modules connected. Failure to do so may cause an error (parameter mismatch of Safety CPU and safety remote I/O module) in the Safety CPU at the restart of the safety remote I/O module.
  - No restrictions are provided on the access level for writing parameters to the safety remote I/O module. However, when the access level is "Users", even though parameters have been set to the safety remote I/O module, safety communications are disabled because the safety communication setting cannot be set in the Safety CPU. To perform the safety communications, set the setting with "Developers" or a higher access level. For details on the access levels, refer to the following.

 GX Works3 Operating Manual

- If the safety remote I/O module is left with "Safety module validation" not being performed for 10 minutes or longer, a minor error (safety module validation not performed) occurs.
-

# 8.1 Module Parameter Setting of the Master Station

The following parameters are required to use the safety remote I/O module. The parameters are automatically set when a safety remote I/O module is added in the "Network Configuration Settings". Change the start number and end number of the RX/Ry Setting or RWw/RWr Setting as necessary.

Item	Description
STA#	Set the station number of the safety remote I/O module.
Station Type	Set "Remote Device Station".
RX/Ry Setting	Points 80 points
RWw/RWr Setting	Points 16 points



- When using the safety remote I/O module, always enable "Station-based Block Data Assurance" of the master station. When it is disabled, correct operation of the safety remote I/O module cannot be guaranteed. For the station-based block data assurance, refer to the following.

MELSEC iQ-R CC-Link IE Field Network User's Manual (Application)

MELSEC iQ-R Simple Motion Module User's Manual (Network)

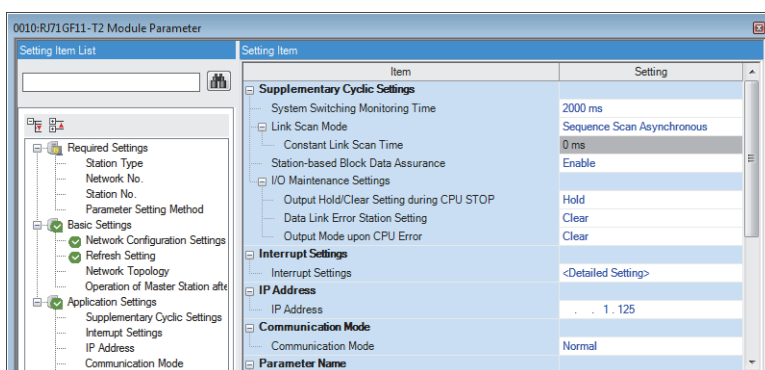

- Do not set the module parameters using the CCPASET instruction in the master station. Correct operation of the safety remote I/O module cannot be guaranteed because the module operates with the Station-based Block Data Assurance disabled when the CCPASET instruction is executed.
- Even though the number of points in the RX/Ry Setting or RWw/RWr Setting and that in a safety remote I/O module differ, an error does not occur on the module. For example, when the number of points in the RX/Ry Setting is set to 16 in a configuration with a safety remote I/O module, only the first 16 points are refreshed.

# Module parameter setting procedure

The following shows the procedure to set module parameters of the master station from the "Network Configuration Settings" window.

## Point

- When the user authentication function of the Safety CPU is enabled, perform the logon of the user authentication function in advance. For the user authentication function, refer to the following.  
 [Page 60 User Authentication Function]
- Connect the module power supply and the load power supply to set parameters. If the power supplies are not connected, parameters cannot be written.

**1.** For preparation before setting module parameters, follow the steps below.

- Connect the safety remote I/O module to a network and power on the module.
- Connect the engineering tool to the Safety CPU of the master station.
- Build the module configuration in the engineering tool. For details on the setting, refer to the following.

[GX Works3 Operating Manual]

- Set the Safety CPU to the TEST MODE. For details on the setting, refer to the following.

[GX Works3 Operating Manual]

**2.** Display the "CC IE Field Configuration" window.

[Navigation window] ⇒ [Parameter] ⇒ [Module Information] ⇒ Target module ⇒ [Module Parameter] ⇒ [Basic Settings] ⇒ [Network Configuration Settings] ⇒ "CC IE Field Configuration" window

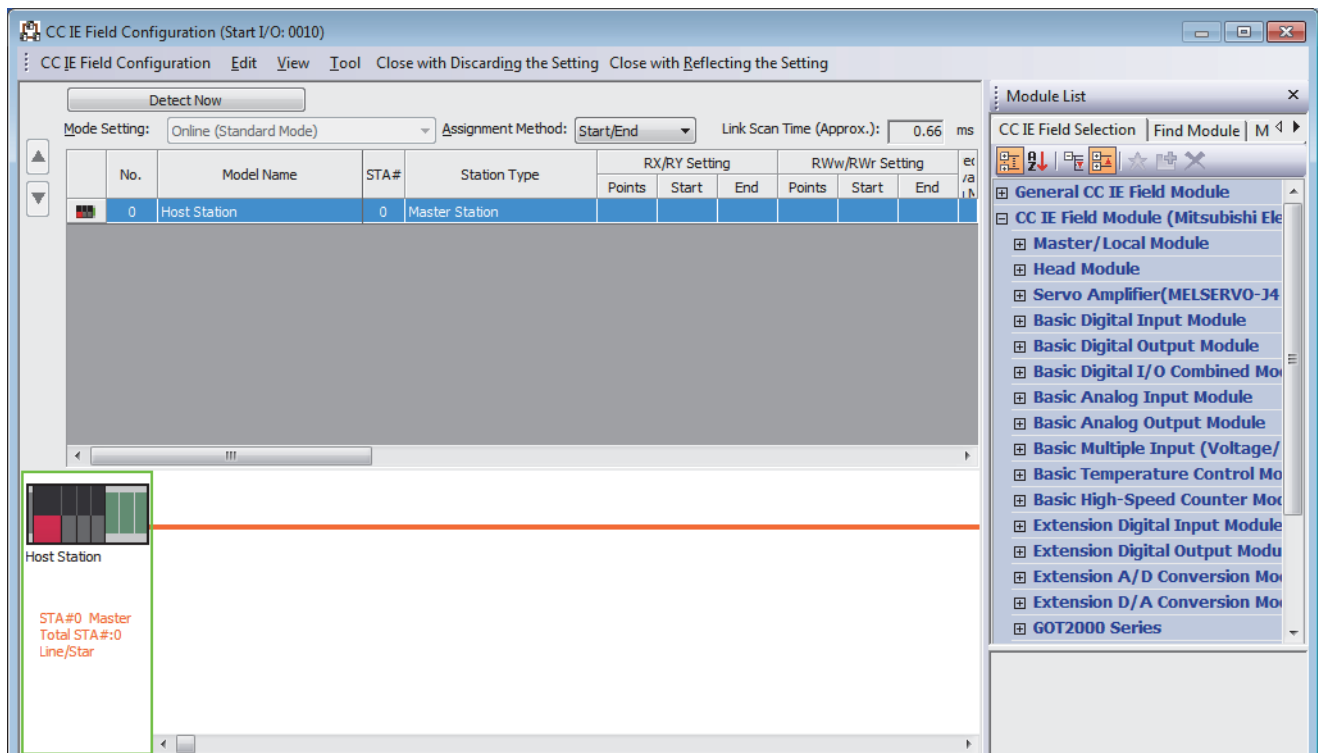

3. Drag and drop the icon of the safety remote I/O module from "Module List" to the lower window. At this time, "STA#", "Station Type", "RX/Ry Setting", and "RWw/RWr Setting" are automatically input. Change a value as necessary.

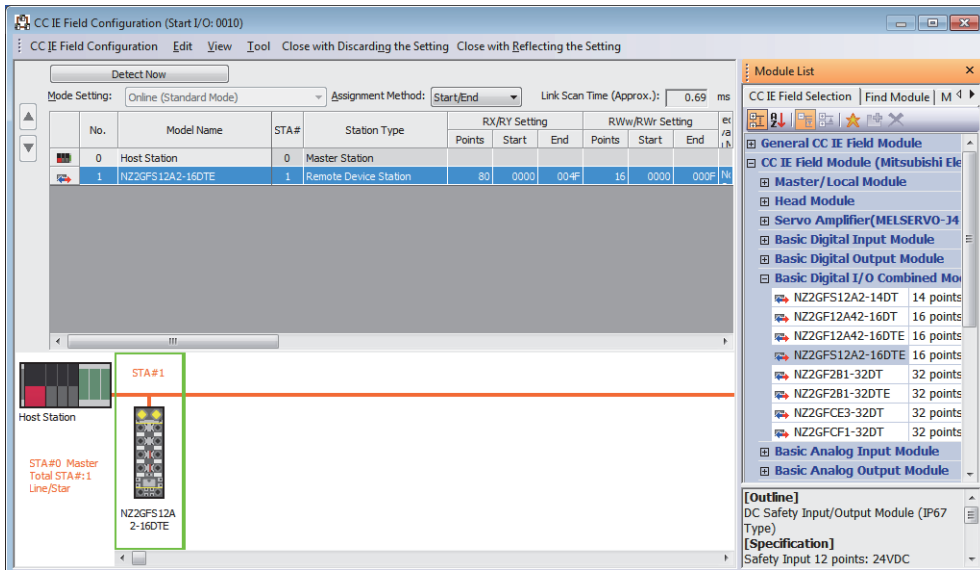

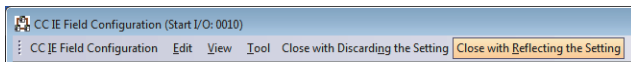

4. Close the "CC IE Field Configuration" window.

 [Close with Reflecting the Setting]



5. After applying the module parameter setting of the master station, write the setting to the programmable controller. For the module parameter setting of the master station, refer to the following.

-  MELSEC iQ-R CC-Link IE Field Network User's Manual (Application)
-  MELSEC iQ-R Simple Motion Module User's Manual (Application)

# 8.2 Module Parameter Setting

## Module parameter setting procedure

The following shows the procedure to set module parameters of the safety remote I/O module from the "Network Configuration Settings" window.

### Point

When the user authentication function of the Safety CPU is enabled, perform the logon of the user authentication function in advance. For the user authentication function, refer to the following.

Page 60 User Authentication Function

1. Display the "CC IE Field Configuration" window.  
 [Navigation window] ⇒ [Parameter] ⇒ [Module Information] ⇒ Target module ⇒ [Module Parameter] ⇒ [Basic Settings] ⇒ [Network Configuration Settings] ⇒ "CC IE Field Configuration" window
2. Display the "Parameter Processing of Slave Station" window.  
 Select the target safety remote I/O module. ⇒ [CC IE Field Configuration] ⇒ [Online] ⇒ [Parameter Processing of Slave Station]

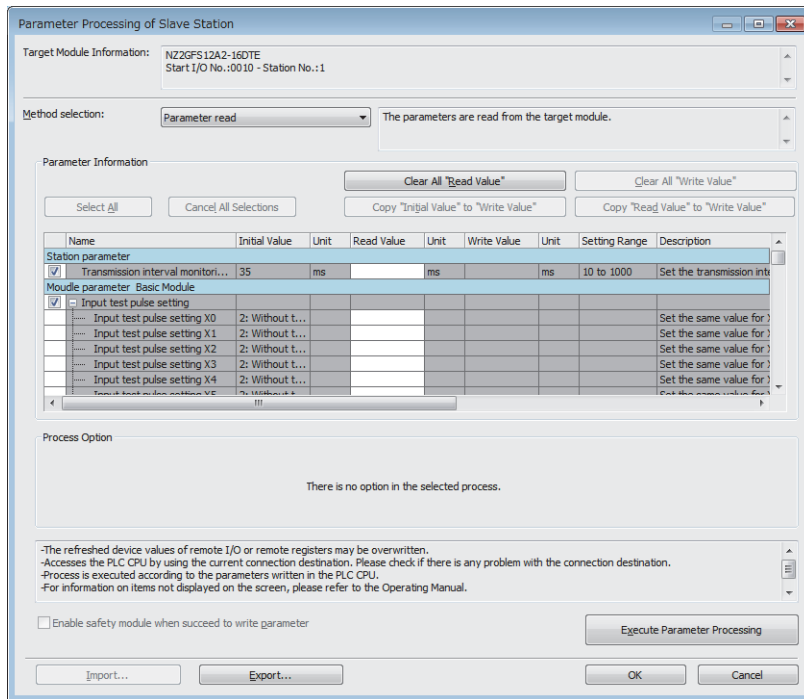

- Set "Method selection" to "Parameter write" so that a value can be set in an item of "Write Value". Set values in all the items of "Write Value". If an item where a value is not set exists, the parameters cannot be written. For the module parameter list for the safety remote I/O module, refer to the following.

☞ Page 72 Module parameter list

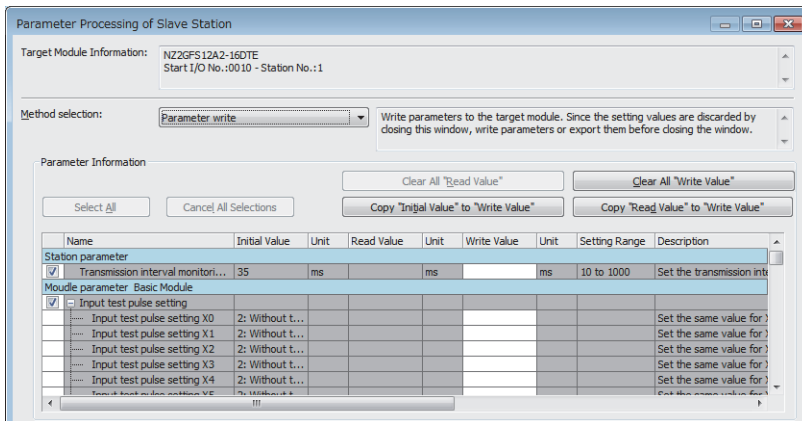

- Click the [Execute] button and a confirmation window is displayed. Check the contents and click the [Yes] button to write the parameters.
- After the parameters are written, a confirmation dialog box is displayed.

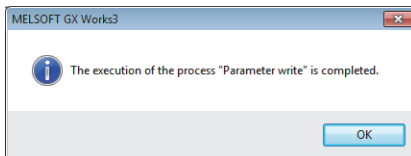

### Point

- When writing parameters has failed, the following window is displayed.

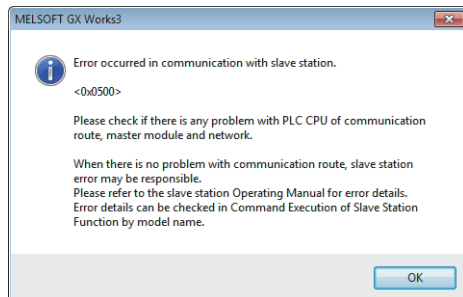

For error codes, refer to the following and take corrective actions.

☞ Page 95 Error Code List

📖 MELSEC iQ-R CC-Link IE Field Network User's Manual (Application)

- When "Parameter write" is executed with the Safety CPU set in SAFETY MODE, an error window is displayed and the parameter writing is stopped. For details on SAFETY MODE, refer to the following.

📖 MELSEC iQ-R CPU Module User's Manual (Application)

- After writing parameters is completed, visually check that the module parameters have been normally written to the module. To check the module parameters, refer to the following.

📖 GX Works3 Operating Manual

- Perform the operations from "Parameter write" to the visual check of the module parameters for all safety remote I/O modules connected.

8. Set the module parameter of the master station "To Use or Not to Use the Safety Communication Setting" to "Use".

[Module Parameter] ⇒ [Application Settings] ⇒ [Safety Communication Setting] ⇒ [To Use of Not to Use the Safety Communication Setting]

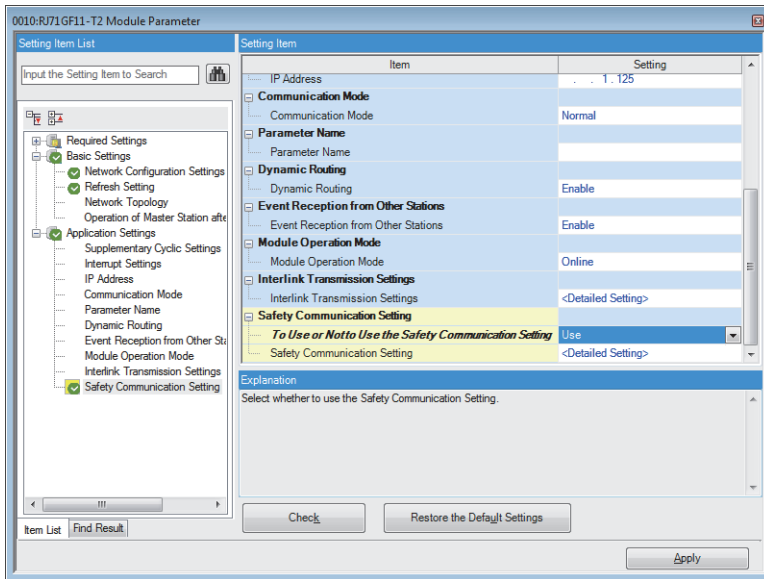

9. Select "Detailed Setting" of the module parameter of the master station "Safety Communication Setting" and the "Safety Communication Setting" window is displayed.

[Module Parameter] ⇒ [Application Settings] ⇒ [Safety Communication Setting] ⇒ [Safety Communication Setting]

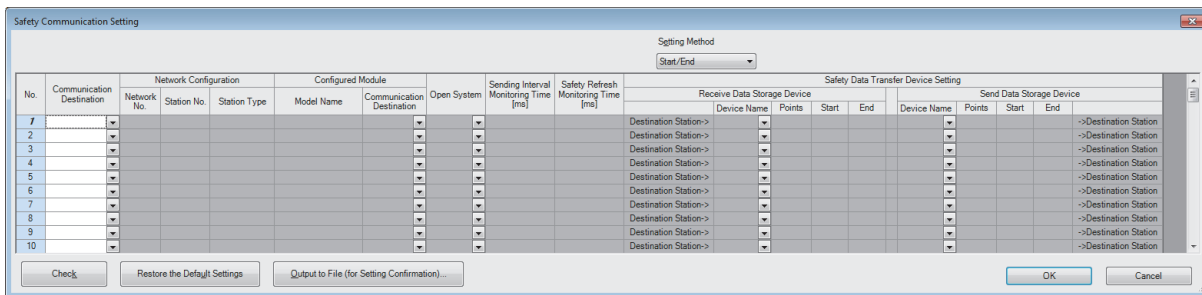

10. Select "Local Network" in "Communication Destination" and the "Select the target module for the Safety Communication Setting" window is displayed. Select the target safety remote I/O module and click the [Add] button.

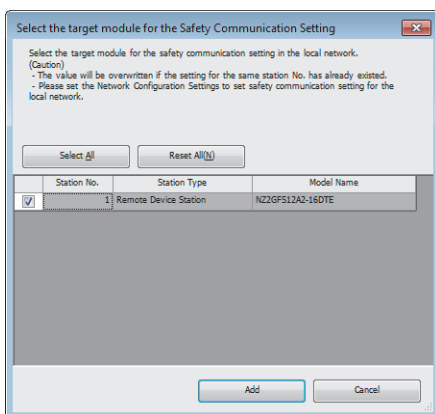

- 11.** The parameters of the safety remote I/O module selected on the "Select the target module for the Safety Communication Setting" window are imported into the safety communication setting. Set "Sending Interval Monitoring Time", "Safety Refresh Monitoring Time", "Safety Data Transfer Device Setting" and click the [OK] button.

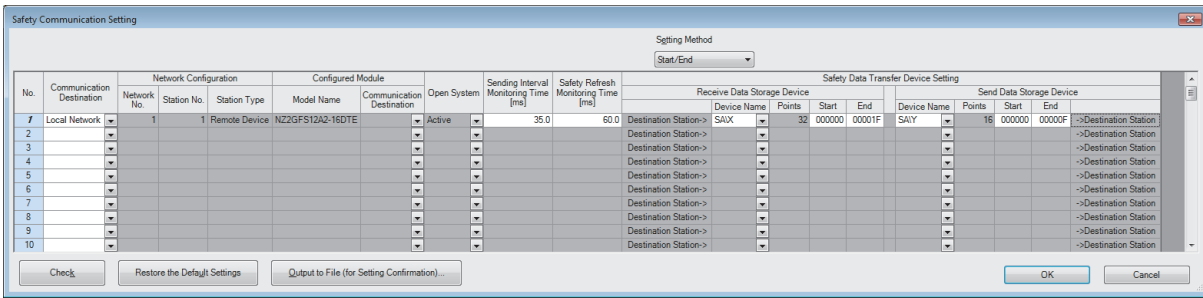

**Point**

For the setting values of "Sending Interval Monitoring Time" and "Safety Refresh Monitoring Time" for the master station, refer to the following.

- 📖 MELSEC iQ-R CC-Link IE Field Network User's Manual (Application)
- 📖 MELSEC iQ-R Simple Motion Module User's Manual (Network)

- 12.** Write the parameters to the programmable controller again.

**Point**

- When newly setting the module parameters of the safety remote I/O module, be sure to set "Safety Communication Setting" and write the parameters to the programmable controller after that.
- When changing the station number or network configuration, be sure to set "Safety Communication Setting" and write the parameters to the programmable controller as well.
- When changing only the module parameters of the safety remote I/O module without changing the station number or network configuration, setting "Safety Communication Setting" is not required. However, be sure to write the parameters to the programmable controller after that.

- 13.** When parameter writing to the programmable controller is completed, select the target safety remote I/O module in the "Network Configuration Settings" and display the "Command Execution of Slave Station" window.

🖱️ [Network Configuration Settings] ⇒ Select the target safety remote I/O module. ⇒ [CC IE Field Configuration] ⇒ [Online] ⇒ [Command Execution of Slave Station]

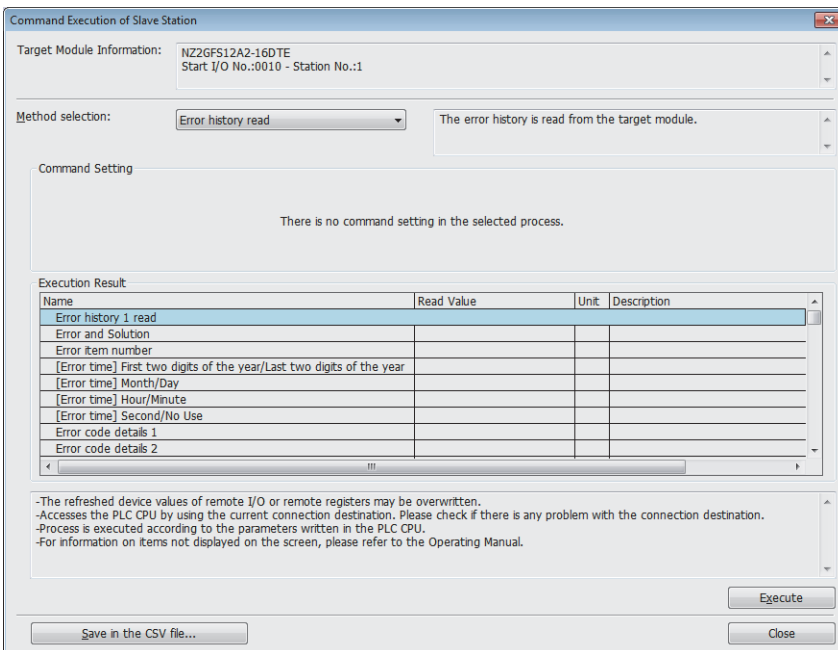



14. Select "Start of checking the module position" in "Method selection" and click the [Execute] button.

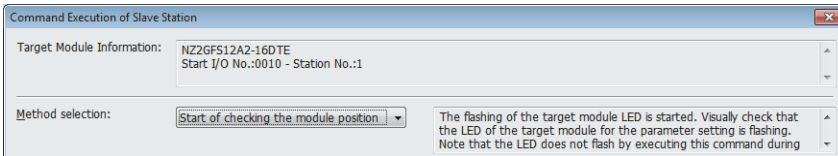

15. Clicking the [Execute] button displays a confirmation window. Check the contents and click the [Yes] button. The SAFETY LED of the selected safety remote I/O module starts flashing. Visually check that the safety remote I/O module on which the SAFETY LED is flashing is installed on the desired position. At the same time, visually check that the SAFETY LEDs of other safety remote I/O modules not targeted for the position checking are not flashing.

16. After checking the module position is completed, select "Stop of checking the module position" in "Method selection" on the "Command Execution of Slave Station" window and click the [Execute] button.

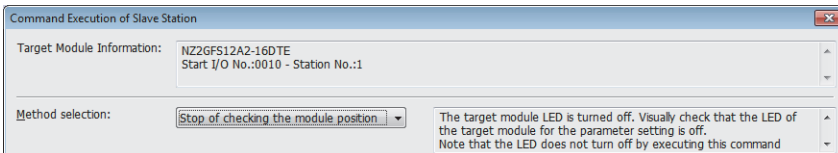

17. Clicking the [Execute] button displays a confirmation window. Check the contents and click the [Yes] button. The SAFETY LED of the safety remote I/O module turns off.

18. Perform the operations from "Start of checking the module position" to "Stop of checking the module position" for all safety remote I/O modules connected.

19. Select "Safety module validation" in "Method selection" and click the [Execute] button.

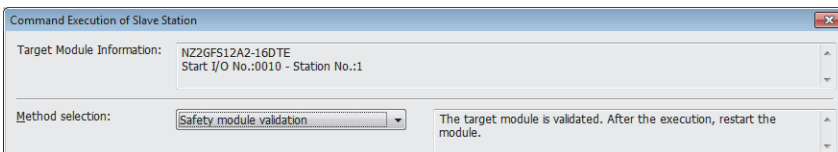

20. Clicking the [Execute] button displays the following confirmation window. Check the contents, and if the operations mentioned on the window are completed, click the [Yes] button. When the operations are not completed, click the [No] button. After performing the operations of "[Confirm 1]" and "[Confirm 2]", perform "Safety module validation" again.

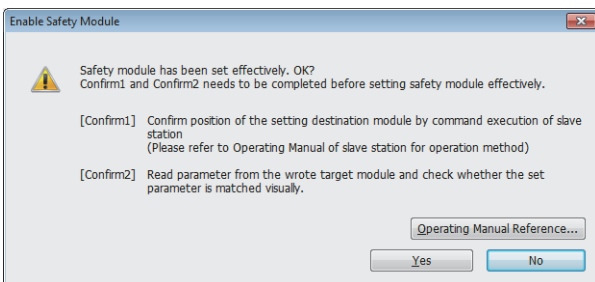

21. Clicking the [Yes] button displays a confirmation window. Check the contents and click the [Yes] button. The following window is displayed and the parameters set to the safety remote I/O module are validated.

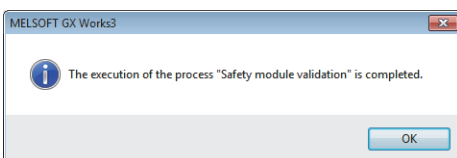

**Point**

When "Safety module validation" is executed with the Safety CPU set in SAFETY MODE, an error window is displayed and the Safety module validation is stopped. For details on SAFETY MODE, refer to the following.  
 📖 MELSEC iQ-R CPU Module User's Manual (Application)

22. Restart the safety remote I/O module. The SAFETY LED turns on and the mode shifts to the safety drive mode.
23. Perform the operations from "Safety module validation" to the restart of the safety remote I/O module for all safety remote I/O modules connected.

### Point

"Safety module validation" is cancelled if the following situations arise after the validation performance.

- The parameters have been set again.
- A parameter data error has occurred.

When the safety remote I/O module where "Safety module validation" has been performed is connected to the different system, the SAFETY LED turns off even though the validation of the safety remote I/O module is not cancelled. Therefore, perform again "Parameter write" and "Safety module validation".

## Module parameter list

This section shows lists of the module parameters of the safety remote I/O module. The following parameters cannot be set from a program.

- Items to input from the pull-down list

Select a setting value from the pull-down list.

- Items to input in the text box

Input a numerical value within "Setting Range" as a setting value.

Parameter Processing of Slave Station

Target Module Information: N22GFS12A2-16DTE  
Start I/O No.:0010 - Station No.:1

Method selection: Parameter write  
Write parameters to the target module. Since the setting values are discarded by closing this window, write parameters or export them before closing the window.

Parameter Information

Select All Cancel All Selections Clear All "Read Value" Clear All "Write Value"  
Copy "Initial Value" to "Write Value" Copy "Read Value" to "Write Value"

Name	Initial Value	Unit	Read Value	Unit	Write Value	Unit	Setting Range	Description
Station parameter								
Transmission interval monitori...	35	ms		ms	35	ms	10 to 1000	Set the transmission int...
Module parameter Basic Module								
Input test pulse setting								
Input test pulse setting X0	2: Without t...				2: Without t...			Set the same value for ...
Input test pulse setting X1	2: Without t...				2: Without t...			Set the same value for ...
Input test pulse setting X2	2: Without t...				2: Without t...			Set the same value for ...
Input test pulse setting X3	2: Without t...				2: Without t...			Set the same value for ...
Input test pulse setting X4	2: Without t...				2: Without t...			Set the same value for ...

Process Option

There is no option in the selected process.

-The refreshed device values of remote I/O or remote registers may be overwritten.  
-Accesses the PLC CPU by using the current connection destination. Please check if there is any problem with the connection destination.  
-Process is executed according to the parameters written in the PLC CPU.  
-For information on items not displayed on the screen, please refer to the Operating Manual.

Enable safety module when succeed to write parameter

Execute Parameter Processing

Import... Export... OK Cancel

## Module parameter (NZ2GFS12A2-16DTE)

### ■ Station parameter

Item	Setting range	Reference
Transmission interval monitoring time	10 to 1000 (ms) (default value: 35)	Page 118 Transmission interval monitoring time

### ■ Parameters per module

Item	Setting range	Reference	
Input test pulse setting	Input test pulse setting X0	1: With test pulse 2: Without test pulse (default)	Page 118 Input test pulse setting
	Input test pulse setting X1		
	Input test pulse setting X2		
	Input test pulse setting X3		
	Input test pulse setting X4		
	Input test pulse setting X5		
	Input test pulse setting X6		
	Input test pulse setting X7		
	Input test pulse setting X8		
	Input test pulse setting X9		
	Input test pulse setting XA		
	Input test pulse setting XB		
Output setting	Output mode setting Y0	1: Not used (default) 2: Output dark test execution 3: Output dark test non-execution	Page 119 Output mode setting/ Output dark test pulse time
	Output mode setting Y1		
	Output mode setting Y2		
	Output mode setting Y3		
	Output dark test pulse time Y0	3 to 100 ( $\times 100\mu\text{s}$ ) (default value: 7)	Page 119 Output mode setting/ Output dark test pulse time
	Output dark test pulse time Y1		
	Output dark test pulse time Y2		
	Output dark test pulse time Y3		
Wiring selection of output	Wiring selection of output Y0/Y1	1: Double wiring (default) 2: Single wiring	Page 119 Wiring selection of output
	Wiring selection of output Y2/Y3		
Input setting	Input ON delay X0	0 to 1000 (ms) (default value: 5)	Page 120 Input ON delay
	Input ON delay X1		
	Input ON delay X2		
	Input ON delay X3		
	Input ON delay X4		
	Input ON delay X5		
	Input ON delay X6		
	Input ON delay X7		
	Input ON delay X8		
	Input ON delay X9		
	Input ON delay XA		
	Input ON delay XB		

Item		Setting range	Reference		
Input setting	Input OFF delay X0	0 to 1000 (ms) (default value: 5)	Page 120 Input OFF delay		
	Input OFF delay X1				
	Input OFF delay X2				
	Input OFF delay X3				
	Input OFF delay X4				
	Input OFF delay X5				
	Input OFF delay X6				
	Input OFF delay X7				
	Input OFF delay X8				
	Input OFF delay X9				
	Input OFF delay XA				
	Input OFF delay XB				
	Input mode setting X0			1: Not used (default) 2: Input dark test execution 3: Input dark test non-execution	Page 120 Input mode setting
	Input mode setting X1				
	Input mode setting X2				
	Input mode setting X3				
	Input mode setting X4				
	Input mode setting X5				
	Input mode setting X6				
	Input mode setting X7				
	Input mode setting X8				
	Input mode setting X9				
	Input mode setting XA				
	Input mode setting XB				
Wiring selection of input	Wiring selection of input X0/X1	1: Double wiring (NC/NC) (default) 2: Double wiring (NC/NO) 3: Single wiring	Page 121 Wiring selection of input		
	Wiring selection of input X2/X3				
	Wiring selection of input X4/X5				
	Wiring selection of input X6/X7				
	Wiring selection of input X8/X9				
	Wiring selection of input XA/XB				
	Double input discrepancy detection time X0/X1	10 to 30000 (ms) (default value: 10)	Page 121 Double input discrepancy detection time		
	Double input discrepancy detection time X2/X3				
	Double input discrepancy detection time X4/X5				
	Double input discrepancy detection time X6/X7				
	Double input discrepancy detection time X8/X9				
	Double input discrepancy detection time XA/XB				

**Point** 

Set all the items of the parameters displayed. If any item is left blank, the parameters cannot be written to the safety remote I/O module.

## Module parameter (NZ2GFS12A2-14DT)

### ■ Station parameter

Item	Setting range	Reference
Transmission interval monitoring time	10 to 1000 (ms) (default value: 35)	Page 118 Transmission interval monitoring time

### ■ Parameters per module

Item	Setting range	Reference	
Input test pulse setting	Input test pulse setting X0	1: With test pulse 2: Without test pulse (default)	Page 118 Input test pulse setting
	Input test pulse setting X1		
	Input test pulse setting X2		
	Input test pulse setting X3		
	Input test pulse setting X4		
	Input test pulse setting X5		
	Input test pulse setting X6		
	Input test pulse setting X7		
	Input test pulse setting X8		
	Input test pulse setting X9		
	Input test pulse setting XA		
	Input test pulse setting XB		
Output setting	Output mode setting Y0+	1: Not used (default) 2: Output dark test execution 3: Output dark test non-execution	Page 119 Output mode setting/ Output dark test pulse time
	Output mode setting Y0-		
	Output mode setting Y1+		
	Output mode setting Y1-		
	Output dark test pulse time Y0	3 to 100 ( $\times 100\mu\text{s}$ ) (default value: 7)	Page 119 Output mode setting/ Output dark test pulse time
	Output dark test pulse time Y1		
Wiring selection of output	Wiring selection of output Y0	1: Double wiring (default)	Page 119 Wiring selection of output
	Wiring selection of output Y1		
Input setting	Input ON delay X0	0 to 1000 (ms) (default value: 5)	Page 120 Input ON delay
	Input ON delay X1		
	Input ON delay X2		
	Input ON delay X3		
	Input ON delay X4		
	Input ON delay X5		
	Input ON delay X6		
	Input ON delay X7		
	Input ON delay X8		
	Input ON delay X9		
	Input ON delay XA		
	Input ON delay XB		
	Input OFF delay X0	0 to 1000 (ms) (default value: 5)	Page 120 Input OFF delay
	Input OFF delay X1		
	Input OFF delay X2		
	Input OFF delay X3		
	Input OFF delay X4		
	Input OFF delay X5		
	Input OFF delay X6		
	Input OFF delay X7		
	Input OFF delay X8		
	Input OFF delay X9		
	Input OFF delay XA		
	Input OFF delay XB		

Item		Setting range	Reference
Input setting	Input mode setting X0	1: Not used (default) 2: Input dark test execution 3: Input dark test non-execution	Page 120 Input mode setting
	Input mode setting X1		
	Input mode setting X2		
	Input mode setting X3		
	Input mode setting X4		
	Input mode setting X5		
	Input mode setting X6		
	Input mode setting X7		
	Input mode setting X8		
	Input mode setting X9		
	Input mode setting XA		
Input mode setting XB			
Wiring selection of input	Wiring selection of input X0/X1	1: Double wiring (NC/NC) (default) 2: Double wiring (NC/NO) 3: Single wiring	Page 121 Wiring selection of input
	Wiring selection of input X2/X3		
	Wiring selection of input X4/X5		
	Wiring selection of input X6/X7		
	Wiring selection of input X8/X9		
	Wiring selection of input XA/XB		
	Double input discrepancy detection time X0/X1	10 to 30000 (ms) (default value: 10)	Page 121 Double input discrepancy detection time
	Double input discrepancy detection time X2/X3		
	Double input discrepancy detection time X4/X5		
	Double input discrepancy detection time X6/X7		
	Double input discrepancy detection time X8/X9		
Double input discrepancy detection time XA/XB			

**Point** 

Set all the items of the parameters displayed. If any item is left blank, the parameters cannot be written to the safety remote I/O module.

# 9 MAINTENANCE AND INSPECTION

This chapter describes the maintenance and inspection of the safety remote I/O module.



Read [Startup and Maintenance Precautions] in the safety precautions carefully before performing the inspection, and observe the precautions.

## 9.1 Daily Inspection

The following table lists the items that must be inspected on a daily basis.

Item	Inspection item	Inspection method	Judgment criterion	Action	
1	Connection status	Check for the looseness of connecting plugs.	The connecting plugs must not be loose.	Make sure that the plugs are securely connected.	
2	LED status in operation	PW LED	Check that the LED is on.	Green (The LED's off indicates an error.)	Refer to the following and take actions. Page 79 Checking the LEDs
		RUN LED	Check that the LED is on.	Green (The LED's off indicates an error.)	
		MODE LED	Check that the LED is on.	Green (The LED's flashing or off indicates an error.)	
		ERR. LED	Check that the LED is off.	Off (The LED's on (red) or flashing (red) indicates an error.)	
		D LINK LED	Check that the LED is on.	Green (The LED's off indicates an error.)	
		SAFETY LED	Check that the LED is on.	Green (The LED's off indicates an error.)	
		I/O LED	Check whether the LED is on, flashing, or off.	Green: Input/output ON Off: Input/output OFF (The LED's flashing indicates the point where an error has occurred.)	
		L PW LED	Check that the LED is on.	Green (The LED's on (red) or off indicates an error.)	
		L ER LED	Check that the LED is off.	Off (The LED's on indicates an error.)	
LINK LED	Check whether the LED is on or off.	The LED's on (green) indicates link-up performed. The LED's off indicates link-up not performed.			

## 9.2 Periodic Inspection

The following table lists the items that must be inspected periodically.

Item	Inspection item		Inspection method	Judgment criterion	Action
1	Environment	Ambient temperature *1	Measure the temperature by using a thermometer.	0 to 55°C	Create the environment that satisfies the judgment criterion.
		Ambient humidity	Measure the humidity by using a hygrometer.	5 to 95%RH	
		Atmosphere	Measure corrosive gases.	No corrosive gases	
2	Power supply voltage check		Measure the voltage across 24VDC terminals.	20.4 to 28.8VDC	Change the supply power.
3	Installation status	Looseness and rattling	Check for looseness or rattling by shaking the module lightly.	The module must be installed securely.	Retighten screws securely.
4	Connection status	Looseness of connecting plugs	Check for looseness by shaking connecting plugs lightly.	The connecting plugs must not be loose.	Make sure that the plugs are securely connected.

\*1 The ambient temperature is a temperature in the control panel when the safety remote I/O module is installed in a control panel.

### Warning

Shut off the power supply externally before cleaning. Failure to do so may cause the module to fail or malfunction.

### Precautions

- Do not disassemble or modify the module. Doing so may cause failure, malfunction, injury, or a fire.
- Shut off the power supply externally (all phases) before mounting or removing the module. Failure to do so may cause the module to fail or malfunction.
- Do not touch any conductive parts and electronic components of the module. Doing so can cause malfunction or failure of the module.



# 10 TROUBLESHOOTING

This chapter describes the errors that may occur while the safety remote I/O module is used and their troubleshooting.

## 10.1 Checking the LEDs

10

This section describes how to troubleshoot the system by the LEDs.

### When the PW LED is on in red

Check item	Action
Is the voltage of the module power supply within the specified range?	Set the voltage value within the range of performance specifications.
Is the operating ambient temperature within the specified range?	Set the operating ambient temperature within the range of general specifications.

### When the PW LED does not turn on

Check item	Action
Is any LED other than the PW LED turned on?	When any LED other than the PW LED turns on, the possible cause is a hardware failure. Please consult your local Mitsubishi representative.
Is the module power supply wired?	Wire the module power supply.
Is the module power supply turned on?	Turn on the module power supply.
Is the voltage of the module power supply within the specified range?	Set the voltage value within the range of performance specifications.

### When the L PW LED is on in red

Check item	Action
Is the voltage of the load power supply within the specified range?	Set the voltage value within the range of performance specifications.
Is the operating ambient temperature within the specified range?	Set the operating ambient temperature within the range of general specifications.

### When the L PW LED does not turn on

Check item	Action
Is the load power supply wired?	Wire the load power supply.
Is the load power supply on?	Turn on the load power supply.
Is the voltage of the load power supply within the specified range?	Set the voltage value within the range of performance specifications.

### When the I/O LED is on in red

Check item	Action
Is the voltage of the load power supply within the specified range?	Set the voltage value within the range of performance specifications.
Is the supply current to the module power supply or the output current whose I/O LED is on in red within the specified range?	Set the current value within the range of performance specifications.
Is the operating ambient temperature within the specified range?	Set the operating ambient temperature within the range of general specifications.
Is any input or output where the LED is on in red short-circuited?	Check the wiring of the input or output and remove the short-circuit.

## When the I/O LEDs flash in red for all points

Check item	Action
Does the voltage of the module power supplied externally reach the voltage of the specifications?	Check that module power supply voltage is within the range of specifications.
Are the device connection and wiring correct?	Check that the device connection and wiring are correct.
Is the operating ambient temperature within the specified range?	Set the operating ambient temperature within the range of general specifications.
Has any hardware failure occurred?	If the same error occurs again even after performing the above actions and turning off and on the module power supply, the module may be in failure. Please consult your local Mitsubishi representative.

The above error is a module stop state (hardware failure), and thus other LEDs may not operate or the error history may not be saved.

## When the RUN LED does not turn on

Check item	Action
Does the voltage of the module power supplied externally reach the voltage of the specifications?	Check that the module power supply voltage is within the range of performance specifications.
Has any hardware failure occurred?	<p>☞ Page 20 Performance Specifications</p> <p>After the check, turn off and on the module power supply.</p> <p>If the RUN LED does not turn on even after the module power supply is turned off and on, the module may be in failure. Please consult your local Mitsubishi representative.</p>

## When the RUN LED flashes

Check item	Action
Does the voltage of the module power supplied externally reach the voltage of the specifications?	Check that module power supply voltage is within the range of specifications.
Are the device connection and wiring correct?	Check that the device connection and wiring are correct.
Has any hardware failure occurred?	If the same error occurs again even after performing the above actions and turning off and on the module power supply, the module may be in failure. Please consult your local Mitsubishi representative.

## When the MODE LED flashes

Check item	Action
Is the safety remote I/O module in execution of the unit test?	<p>When the safety remote I/O module is in execution of the unit test, the MODE LED turns off after the unit test is completed. Take corrective action according to the result of the unit test.</p> <p>☞ Page 88 Unit Test</p>

## When the ERR. LED flashes or turns on

Check item	Action
Has any error occurred?	<p>Identify the error factor of the safety remote I/O module with the engineering tool and take corrective actions.</p> <p>☞ Page 85 Checking error codes and warning codes</p>

### When the D LINK LED turns off

Check item	Action
Does the own station in network operate normally?	Connect the engineering tool to the master station, and then check that a data link is established in the own station by using CC IE Field diagnostics. ☞ User's manual for the master/local module used
Are 1000BASE-T-compliant Ethernet cables used?	Replace the cable with a 1000BASE-T-compliant Ethernet cable. ☞ User's manual for the master/local module used
Is the station-to-station distance 100m or less?	Change the station-to-station distance to 100m or less.
Does the cabling condition (bending radius) meet the specifications?	Refer to the manual for the Ethernet cable used, and correct the bending radius.
Is any Ethernet cable disconnected?	Replace the Ethernet cable.
Are other stations connected to the safety remote I/O module normally operating?	Check that the power supplies of the other stations are turned on.
Does the switching hub normally operate?	<ul style="list-style-type: none"> <li>• Check that a 1000BASE-T-compliant switching hub is used.</li> </ul> ☞ User's manual for the master/local module used <ul style="list-style-type: none"> <li>• Check that the power supply of the switching hub is turned on.</li> </ul>
Is a same station number set to both the safety remote I/O module and any of other stations?	Two or more stations use a same station number. Change the setting so that all the station numbers are different.

### When the D LINK LED flashes

Check item	Action
Does the station number setting of the safety remote I/O module match the station number of the safety remote I/O module specified in the network configuration settings of the master station or in the CC IE Field Configuration?	Match the station number of the safety remote I/O module with the station number specified in the network configuration settings of the master station or in the CC IE Field Configuration.
Does the station type match?	Match the station type of the safety remote I/O module with the station type specified in the network configuration settings of the master station or in the CC IE Field Configuration.
Is the safety remote I/O module a reserved station?	Change the setting of reserved/error invalid station to other than the reserved station in the network configuration settings of the master station.
Is the station number setting switch set to other than 1 to 120?	Change the setting within the range from 1 to 120.
Is stop of the data link checked through CC-Link IE Field Network diagnostics?	Check the link status through CC-Link IE Field Network diagnostics and start the link when the data link is stopped.
Has the connection been changed to the other master station with a different network number?	<ul style="list-style-type: none"> <li>• Correct the connection to the previous master station.</li> <li>• To communicate with the master station with a different network number, switch the power supply of the safety remote I/O module off and on.</li> </ul>

### When the L ER LED turns on

Check item	Action
Are Ethernet cables normal?	<ul style="list-style-type: none"> <li>• Check that 1000BASE-T-compliant Ethernet cables are used.</li> </ul> ☞ User's manual for the master/local module used <ul style="list-style-type: none"> <li>• Check that the station-to-station distance is 100m or less.</li> <li>• Check that the Ethernet cables are not disconnected.</li> </ul>
Does the switching hub in the system normally operate?	<ul style="list-style-type: none"> <li>• Check that a 1000BASE-T-compliant switching hub is used.</li> </ul> ☞ User's manual for the master/local module used <ul style="list-style-type: none"> <li>• Check that the power supply of the switching hub is turned on.</li> </ul>
Are other stations connected to the safety remote I/O module normally operating?	Check that the power supplies of the other stations are turned on.
Is the mode of the module on the master station set to other than Online?	Change the mode of the module to Online.
Is there any noise affecting the system?	<ul style="list-style-type: none"> <li>• Check the status of wiring.</li> <li>• Ground the control panel or the steel shelf where a safety remote I/O module is installed.*1</li> </ul>
Is the loopback function enabled for the master station?	When the loopback function is enabled, check that the ring topology is correctly configured for the PORT where the L ER LED is on. ☞ User's manual for the master/local module used

\*1 When the safety remote I/O module is installed in the control panel or steel shelf, the FG metal fitting of the safety remote I/O module can be connected electrically with them. Thus, if the control panel or steel shelf is not properly grounded, the noise may enter the FG through the control panel or steel shelf.

## When the LINK LED turns off

Check item	Action
Are Ethernet cables normal?	<ul style="list-style-type: none"> <li>• Check that 1000BASE-T-compliant Ethernet cables are used.</li> <li>📖 User's manual for the master/local module used</li> <li>• Check that the station-to-station distance is 100m or less.</li> <li>• Check that the Ethernet cables are not disconnected.</li> </ul>
Do the switching hub and other stations in the system normally operate?	<ul style="list-style-type: none"> <li>• Check that a 1000BASE-T-compliant switching hub is used.</li> <li>📖 User's manual for the master/local module used</li> <li>• Check that the power supplies of the switching hub and other stations are turned on.</li> </ul>

### Point

If link-up processing is repeated due to a condition of a device on the line, it may take a longer time for the LINK LED to turn on.

This phenomenon may be eliminated by changing the module PORT into which the Ethernet cable is connected (example: PORT1 → PORT2).

## When the SAFETY LED turns off

Check item	Action
Have parameters been set to the safety remote I/O module?	Set the parameters of the safety remote I/O module. 📖 Page 67 Module parameter setting procedure
Has the safety communication setting been configured?	Configure the safety communication setting. Then, write the parameters to the programmable controller. For the safety communication setting, refer to the following. 📖 User's manual for the CPU module used
Has the safety module validation been performed?	Perform the safety module validation using the engineering tool.
Has the safety station interlock of the Safety CPU been canceled?	Fully check the wiring and connection, and cancel the safety station interlock of the Safety CPU. For the safety station interlock, refer to the following. 📖 User's manual for the CPU module used
Has any error occurred?	Identify the error factor with the engineering tool and take corrective actions.
Is the operating ambient temperature within the specified range?	Set the operating ambient temperature within the range of general specifications. 📖 Page 19 General Specifications

# 10.2 Checking Module Status

## Checking with the engineering tool

When the data link is established between the safety remote I/O module and the master station, errors can be checked on the engineering tool.

- Page 83 Checking with "Command Execution of Slave Station"
- Page 85 Checking error codes and warning codes

### Point

When the user authentication function of the Safety CPU is enabled, perform the logon of the user authentication function in advance. For the user authentication function, refer to the following.

- Page 60 User Authentication Function

## Checking with "Command Execution of Slave Station"

The following describes how to check errors with "Command Execution of Slave Station" in the "Network Configuration Settings".

1. Select the safety remote I/O module in "List of stations" on the "CC IE Field Configuration" window.

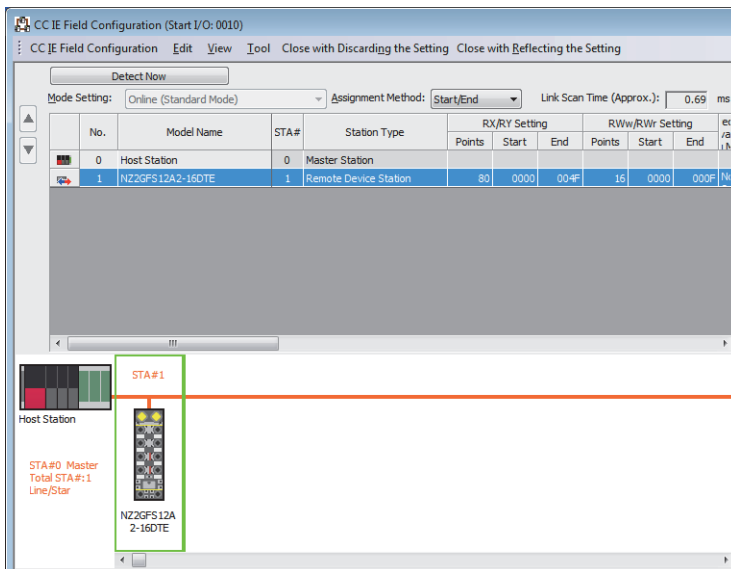

2. Open the "Command Execution of Slave Station" window.

[CC IE Field Configuration] ⇒ [Online] ⇒ [Command Execution of Slave Station]

3. Set "Method selection" to "Error history read" and click the [Execute] button.

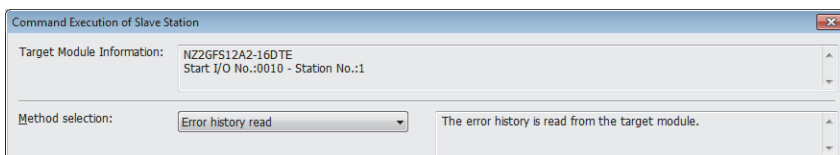

4. Clicking the [Execute] button displays a confirmation window. Check the contents and click the [Yes] button to read the error history data.

5. When the following window is displayed, click the [OK] button.

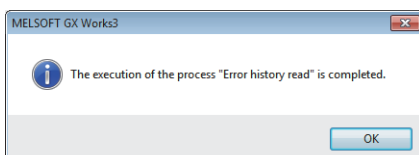

6. The error history of the safety remote I/O module is displayed in "Execution Result".

Execution Result			
Name	Read Value	Unit	Description
Error history 1 read			
Error and Solution	0201H Safety module valid...		
Order of occurrence No.	18		
[Error time] First two digits of the year/Last two digits of the year	2018		
[Error time] Month/Day	1122		
[Error time] Hour/Minute	1109		
[Error time] Second/No Use	2700		
Error code details 1	0x0002		
Error code details 2	0x0000		

Item	Contents	Storage example*1
Error and Solution	Error codes and error details of the errors that have occurred are displayed.	—
Order of occurrence No.	The order of error occurrence is displayed. (A value between 0 and 65535 is stored.)	—
[Error time] First two digits of the year/Last two digits of the year*2	The date and hour of error occurrence is displayed. (When the tens place of Month, Hour, and Second is "0", "0" is omitted.)	2015
[Error time] Month/Day*2		829
[Error time] Hour/Minute*2		1035
[Error time] Second/No Use*2		4000
Error code details 1 to Error code details 8	The detailed information of some errors is stored. The data to be stored depends on the error.  Page 98 Error code details	—

\*1 Values of when an error occurs at 10:35:40, August 29th, 2015

\*2 The clock information of the error that occurred is based on the clock information acquired from the Safety CPU of the master station. When an error has occurred before the clock information is acquired from the Safety CPU, the error time is not recorded.

**Point** 

- The error history registers 15 errors at a maximum. If 16 or more errors occur, errors are deleted from the oldest.
- If the same error occurs continuously, only the error that occurred latest is stored to the error history. Thus, "Order of occurrence No." and "Error time" of the error history are updated at the timing an error occurs.
- Even after the module power supply is turned off and on, the error history remains.
- The clock information of the error that occurred is based on the clock information acquired from the Safety CPU of the master station. To obtain the exact occurrence time of an error, set the clock information of the Safety CPU to the actual time.
- To initialize the error history, set "Method selection" to "Error history clear request" on the "Command Execution of Slave Station" window and click the [Execute] button.

## Checking error codes and warning codes

The latest error code and warning code of the safety remote I/O module can be checked with the remote register of the master station.

### ■Checking the Error code (RX10 to RX1F)

Check the error codes with the remote register of the master station.

 [Online] ⇒ [Monitor] ⇒ [Device/Buffer Memory Batch Monitor]

**Ex.**

When the refresh target device for Error code (RX10 to RX1F) is W101

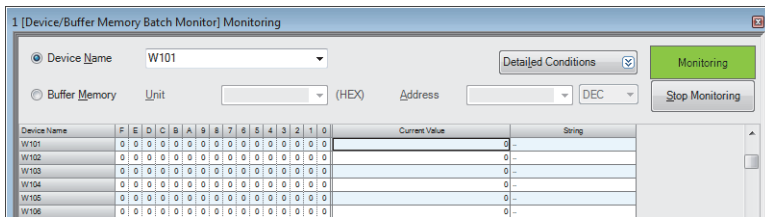

### ■Checking the Warning code (RX20 to RX2F)

Check the warning codes with the remote register of the master station.

 [Online] ⇒ [Monitor] ⇒ [Device/Buffer Memory Batch Monitor]

**Ex.**

When the refresh target device for Warning code (RX20 to RX2F) is W102

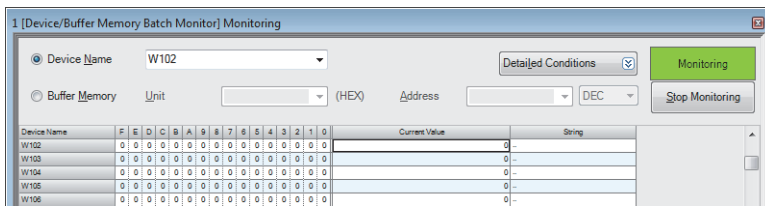

# 10.3 Checking Network Status

With CC-Link IE Field Network diagnostics, whether any network error has occurred or not can be checked through the engineering tool connected to the Safety CPU.

## How to use

1. Connect the engineering tool to the Safety CPU.
2. Start the CC-Link IE Field Network diagnostics from the menu of the engineering tool.

 [Diagnostics] ⇒ [CC-Link IE Field Diagnostics]

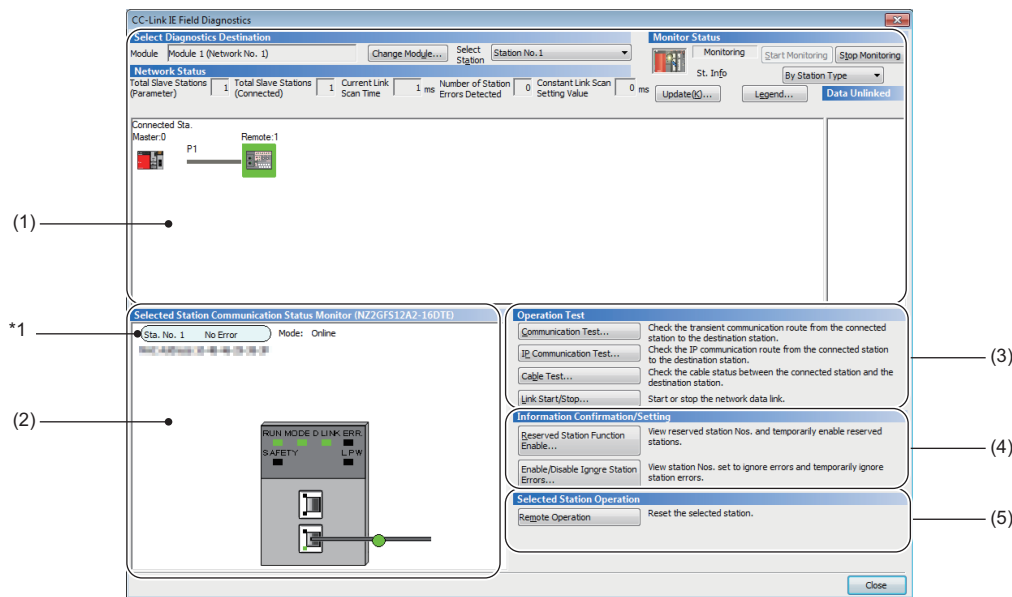

Item to be diagnosed	Description	Reference
(1)	<ul style="list-style-type: none"> <li>Display of network configuration diagram and error status</li> <li>Display of cable disconnection and disconnected station</li> </ul>	<ul style="list-style-type: none"> <li>MELSEC iQ-R CC-Link IE Field Network User's Manual (Application)</li> <li>MELSEC iQ-R Simple Motion Module User's Manual (Network)</li> </ul>
(2)	<ul style="list-style-type: none"> <li>Display of selected-station status and error details</li> <li>Station number setting of slave stations</li> </ul>	
(3)	<ul style="list-style-type: none"> <li>Communication Test</li> <li>IP Communication Test</li> <li>Cable Test</li> <li>Link Start/Stop</li> </ul>	<ul style="list-style-type: none"> <li>The transient communication route and whether the communication is established from the connected station to the destination station can be checked.</li> <li>The reaching time and the route of the IP communication from the connected station to the target station can be checked. This function cannot be used for the safety remote I/O module.</li> <li>The cable status between the connected station and the destination station can be checked.</li> <li>The network data link can be started or stopped.</li> </ul>
(4)	<ul style="list-style-type: none"> <li>Reserved Station Function Enable</li> <li>Enable/Disable Ignore Station Errors</li> </ul>	<ul style="list-style-type: none"> <li>A reservation for a station can be temporarily cleared, and the clearing can be canceled. Also, the station numbers for the modules set as reserved stations can be checked on a list.</li> <li>A station not set as an error invalid station can be temporarily set as an error invalid station, and the error invalid station setting can be canceled. Also, the station numbers for the modules set as (temporary) error invalid stations can be checked on a list.</li> </ul>
(5)	Remote Operation	<ul style="list-style-type: none"> <li>Page 87 Remote operation</li> </ul>



\*1 The information displayed on the upper left of "Selected Station Communication Status Monitor" indicates the communication status of the safety remote I/O module and does not indicate the error status of the selected module. For the error status of the module, refer to the following.

☞ Page 83 Checking Module Status

## Remote operation

1. Select a slave station to be reset and click the [Remote Operation] button.

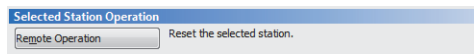

2. Clicking the [Yes] button starts the remote reset.

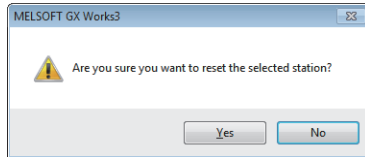

3. Click the [OK] button.

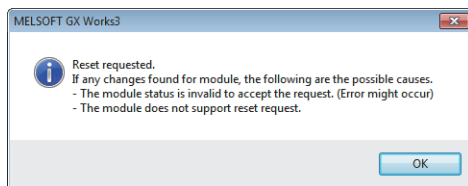

## 10.4 Unit Test

Run a unit test to check if there is any hardware failure in the safety remote I/O module.

1. Turn off the module power supply.
2. Connect the PORT1 and PORT2 connectors of the safety remote I/O module with an Ethernet cable.

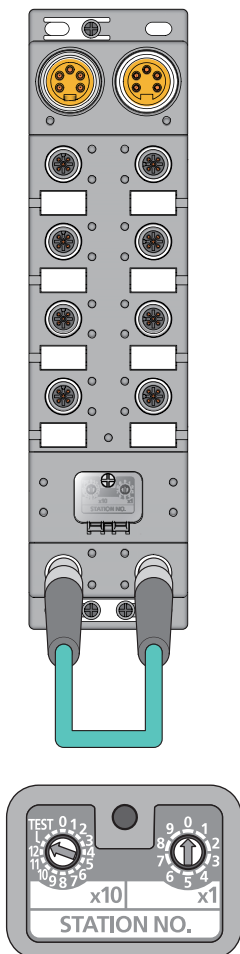

3. Set the station number setting switch as follows.
  - x10: TEST
  - x1: 0

For the setting procedure of the station number setting switch, refer to the following.

☞ Page 35 Setting procedure

4. Turn on the module power supply.
5. Unit test begins.

The MODE LED flashes while the unit test is being executed.

6. The MODE LED turns off when the unit test is completed.
  - If the test is completed normally, the ERR. LED does not turn on, but remains off.
  - If the test fails, the ERR. LED turns on. If the test fails, replace the Ethernet cable and run the test again. If the test fails again, it may be due to a hardware failure in the safety remote I/O module. Please consult your local Mitsubishi representative.

# 10.5 Troubleshooting by Symptom

This section describes troubleshooting for each phenomenon.

Perform the troubleshooting by symptom when the safety remote I/O module does not operate properly with no error. If an error occurs in the safety remote I/O module, identify the cause of the error using the engineering tool.

Check the following items in the order from the top.

## When the ON/OFF status of an external input cannot be read

Check item	Action
Is the SAFETY LED on?	When the SAFETY LED is not on, the safety module validation has not been performed or the Safety CPU is in the safety station interlock status. Take the following actions. <ul style="list-style-type: none"> <li>• Perform the safety module validation. For the safety module validation, refer to the following.               <ul style="list-style-type: none"> <li>☞ Page 67 Module parameter setting procedure</li> </ul> </li> <li>• Fully check the wiring and connection, and cancel the safety station interlock of the Safety CPU. For the safety station interlock, refer to the following.               <ul style="list-style-type: none"> <li>📖 MELSEC iQ-R CPU Module User's Manual (Application)</li> </ul> </li> </ul>
Is the corresponding I/O LED of the safety remote I/O module on when an external input device is on?	If the LED does not turn on, there is a problem on the input wiring. Check the wiring confirming that the input wiring is not disconnected or short-circuited, or the voltage of the input signal is correct. For the rated input voltage range, refer to the following. <ul style="list-style-type: none"> <li>☞ Page 20 Performance Specifications</li> </ul> Refer to the following as well. <ul style="list-style-type: none"> <li>☞ Page 91 Troubleshooting for input circuit</li> </ul>
Is the setting of the refresh device correct?	Check and correct the device setting of the safety communication setting so that the setting of the refresh device matches the setting in the program. For details on the device setting of the safety communication setting, refer to the following. <ul style="list-style-type: none"> <li>📖 MELSEC iQ-R CC-Link IE Field Network User's Manual (Application)</li> <li>📖 MELSEC iQ-R Simple Motion Module User's Manual (Network)</li> </ul>
Is there any incorrect setting in the wiring selection of input?	Review the settings in the wiring selection of input. <ul style="list-style-type: none"> <li>☞ Page 45 Input wiring selection function</li> </ul>





## When the ON/OFF status of an external output cannot be changed

Check item	Action
Is the SAFETY LED on?	When the SAFETY LED is not on, the safety module validation has not been performed or the Safety CPU is in the safety station interlock status. Take the following actions. <ul style="list-style-type: none"> <li>• Perform the safety module validation. For the safety module validation, refer to the following.               <ul style="list-style-type: none"> <li>☞ Page 67 Module parameter setting procedure</li> </ul> </li> <li>• Fully check the wiring and connection, and cancel the safety station interlock of the Safety CPU. For the safety station interlock, refer to the following.               <ul style="list-style-type: none"> <li>📖 MELSEC iQ-R CPU Module User's Manual (Application)</li> </ul> </li> </ul>
Is the corresponding I/O LED of the safety remote I/O module on?	If the LED turns on, there is a problem on the output wiring. Check the wiring confirming that the output wiring is not disconnected or short-circuited. Refer to the following as well. <ul style="list-style-type: none"> <li>☞ Page 93 Troubleshooting for output circuit</li> </ul>
Is the setting of the refresh device correct?	Check and correct the refresh parameter so that the setting of the refresh device matches the setting in the program. For the setting of the refresh parameter, refer to the following. <ul style="list-style-type: none"> <li>📖 MELSEC iQ-R CC-Link IE Field Network User's Manual (Application)</li> <li>📖 MELSEC iQ-R Simple Motion Module User's Manual (Network)</li> </ul>
Is there any incorrect setting in the wiring selection of output?	Review the settings in the wiring selection of output. <ul style="list-style-type: none"> <li>☞ Page 50 Output wiring selection function</li> </ul>

## When External output ON signal intermittently turns off

Check item	Action
Is an output dark test being executed?	Check the specifications of the safety devices used, and review the setting of the output dark test pulse OFF time. <ul style="list-style-type: none"> <li>☞ Page 57 Output dark test function</li> </ul>

## When the safety remote I/O module cannot be accessed using the engineering tool

Check item	Action
Is the D LINK LED on?	<p>Check the D LINK LED. When the LED is not on, refer to the following to perform troubleshooting.</p> <ul style="list-style-type: none"> <li>•  Page 81 When the D LINK LED turns off</li> <li>•  Page 81 When the D LINK LED flashes</li> </ul> <p>Refer to the following to check other LEDs.</p> <ul style="list-style-type: none"> <li>•  Page 79 Checking the LEDs</li> </ul>
Is the version of the module on the master station correct?	<p>Check the firmware version of the module on the master station, and if the version is not the applicable one, replace the module with a module of the applicable version or later. For the applicable version, refer to the following.</p> <ul style="list-style-type: none"> <li>•  Page 33 Applicable products</li> </ul>
Is the version of the engineering tool supported?	<p>Check the version of the engineering tool, and if the version is not the applicable one, update the engineering tool. For the applicable version, refer to the following.</p> <ul style="list-style-type: none"> <li>•  Page 33 Software package</li> </ul>
Do the network parameter settings of the master station and those of the Safety CPU match?	<p>Perform "Verify with PLC" on the network parameters to check that those settings match. When they do not match, execute "Write to PLC" and "Read from PLC" to match the network parameter settings, and write the module parameters of the slave station.</p>

# 10.6 Fault Examples with the Safety Remote I/O Module

## Troubleshooting for input circuit

This section describes the troubleshooting for input circuit.

### An input signal does not turn off.

#### ■Cause

- Drive by a switch with LED indicator (test pulse not used)

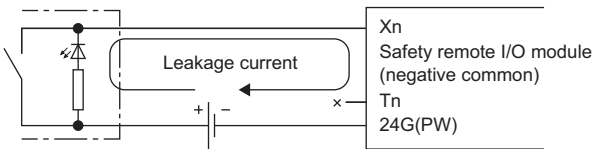

- Drive by a switch with LED indicator (test pulse used)

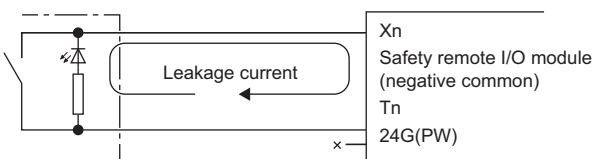

#### ■Action

Connect an appropriate resistor as shown below so that a current through the safety remote I/O module may become lower than the OFF current.

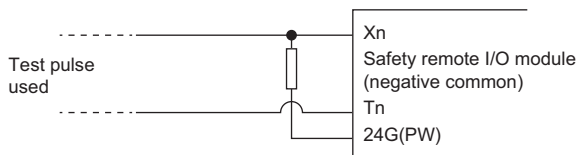
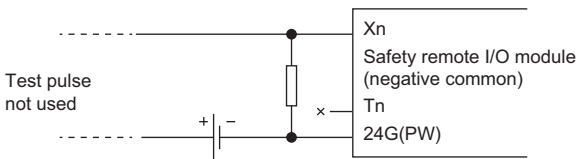

For the calculation example of a resistor to be connected, refer to the following.

☞ Page 91 Calculation example

#### ■Calculation example

When the module power supply of the safety remote I/O module is on and a switch with LED indicator that has a leakage current of 2mA at a maximum is connected

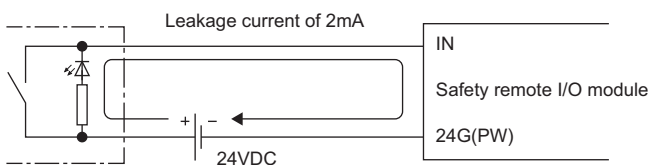

1. The OFF current through the safety remote I/O module is more than 1.5mA. Therefore, connect a resistor as shown below.

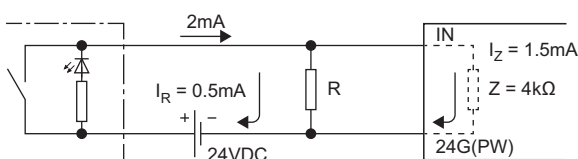

Z: Input impedance

2. To ensure that the OFF current of the safety remote I/O module is 1.5mA or lower, the current through the connected resistor should be 0.5mA or more, so that the value of the connected resistor is lower than 12 kΩ.

$$I_R: I_Z = Z: R$$

$$R \leq \frac{I_Z}{I_R} \times Z = \frac{1.5}{0.5} \times 4 = 12[\text{k}\Omega]$$

3. When the resistor (R) is 5.6 kΩ, the power capacity (W) of the resistor (R) becomes 0.125W.

$$W = V^2 \div R = 26.4^2 \div 5600 = 0.125[\text{W}]$$

V: Input voltage

4. Because the resistor requires the power capacity of 3 to 5 times as large as the actual current consumption, the resistor connected to the terminal should be 5.6 kΩ, and 0.5 to 0.75W.
5. OFF voltage when the resistor (R) is connected becomes 4.67V. This satisfies the condition that the OFF voltage of the safety remote I/O module must be 5V or lower.

$$\frac{1}{\frac{1}{5.6[\text{k}\Omega]} + \frac{1}{4[\text{k}\Omega]}} \times 2[\text{mA}] = 4.67[\text{V}]$$

## A signal incorrectly inputs data

### ■Cause

Noise is taken as input data.

### ■Action

- Set a long input ON/OFF delay.

**Ex.**

1ms → 5ms

For the setting procedure, refer to the following.

☞ Page 49 Input ON delay, input OFF delay functions

If the above change has no effect, take the following two measures:

- To prevent excessive noise, avoid installing power cables together with I/O cables.
- Connect surge absorbers to noise-generating devices such as relays and conductors using the same power supply or take other noise reduction measures.

# Troubleshooting for output circuit

This section describes the troubleshooting for output circuit.

## A load momentarily turns on when the load power supply is powered on

### ■Cause

When an inductive load is connected, the load [2] in the off state may turn on due to a sneak current from the back EMF at the shutoff [1].

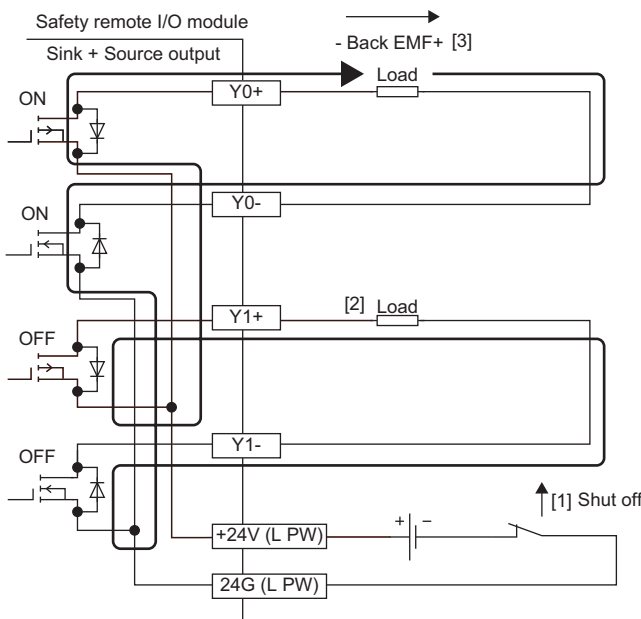
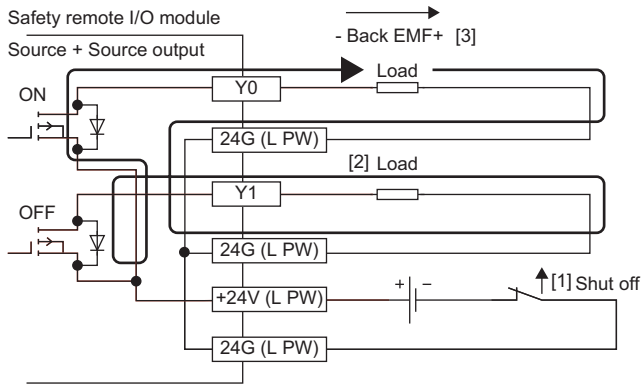

### ■Action

Take the action 1 or action 2 shown below.

1. To suppress the back EMF, connect a diode parallel to the load where the back EMF has been generated.

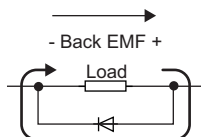

2. Provide another current path by connecting a diode across positive and negative of the load power supply. When taking the action described in Example 1 at a time, connect a diode parallel to C1 and R1.

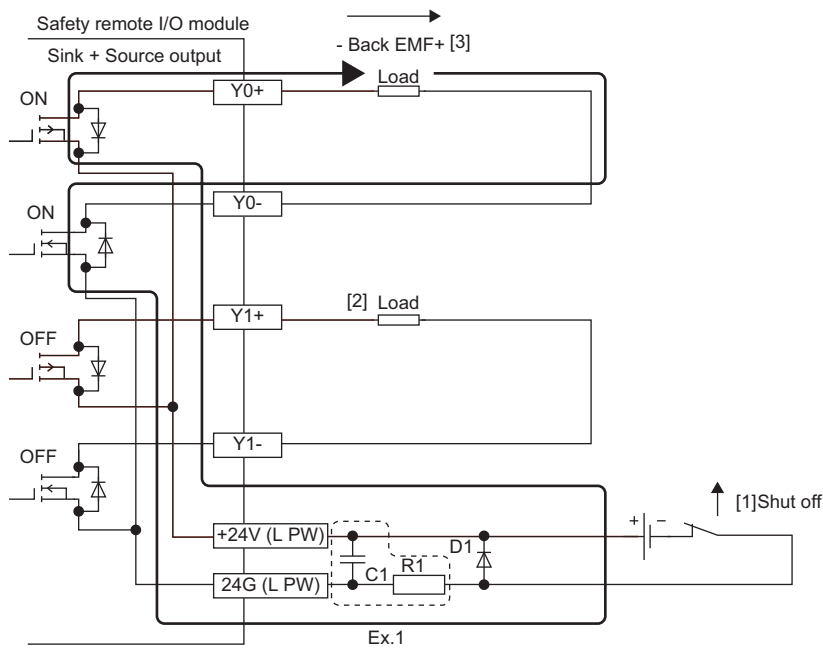
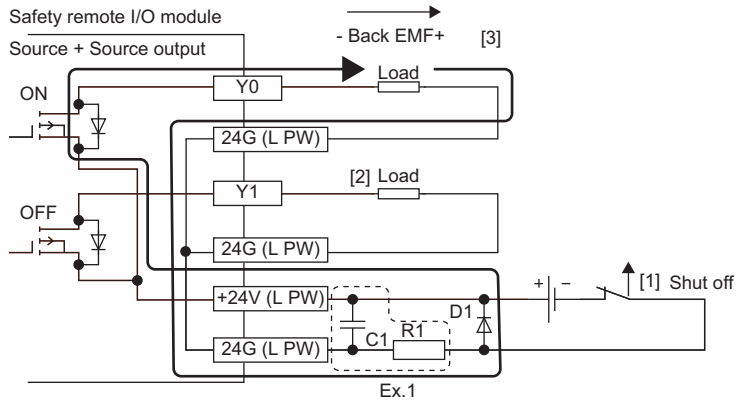

D1:

Reverse voltage VR (VRM)<sup>\*1</sup>

Forward current IF (IFM)<sup>\*2</sup>

\*1 Approximately 10 times as large as the rated voltage in the specifications  
Example: 24VDC → Approximately 200V

\*2 Twice as much as the maximum load current in the specifications or more  
Example: 8A → 16A or higher



# 10.7 Error Code List

## Error codes related to the safety remote I/O module

Errors of the safety remote I/O module are classified into the following three types.

Error status <sup>*1</sup>	Description
Major error	Error because of which the module stops, such as hardware failure. The safety functions (safety I/O, safety diagnostics, and safety communications) stop.
Moderate error	Error because of which the module stops, such as a parameter error related to module operation. The safety functions (safety I/O, safety diagnostics, and safety communications) stop.
Minor error	Error after which the module continues its operation, such as double input discrepancy detection. The safety functions keep operating.

\*1 When multiple errors have occurred, the error statuses are displayed in the order of error severity (Major error > Moderate error > Minor error).

### List of error codes

Error code (hexadecimal)	Classification	Error name	Description and cause	Action
0001H	Major error	Hardware failure	A hardware failure was detected.	Set the operating ambient temperature within the range of general specifications. If the operating ambient temperature is within the range of general specifications, there may be an influence from noise or a hardware failure. If the same error occurs again even after measures have been taken against noise, the module may be in failure. Please consult your local Mitsubishi representative.
0101H	Moderate error	Self-diagnostic error	An error was detected by the self-diagnostics.	
0102H <sup>*1</sup>	Moderate error	Overload error	Overcurrent was detected in the input power supply or output power supply.	<ul style="list-style-type: none"> <li>Review the connected devices, wiring, and voltage.</li> <li>Power on the load power supply at the same timing of power-on of the module power supply.</li> <li>If the same error occurs again, the module may be in failure. Please consult your local Mitsubishi representative.</li> </ul>
0103H	Moderate error Restoration possible <sup>*2</sup>	Power supply voltage error	An error was detected in the module power supply or load power supply.	<ul style="list-style-type: none"> <li>Review the connected devices, wiring, and voltage.</li> <li>Power on the load power supply at the same timing of power-on of the module power supply.</li> <li>There may be an influence from noise of external wiring (such as power supply part and I/O signal part). Review the connected devices and wiring.</li> <li>If the same error occurs again, the module may be in failure. Please consult your local Mitsubishi representative.</li> </ul>
0105H	Moderate error	Date out of range error	Incorrect clock data was received from the CPU module.	There may be an influence from noise or a hardware failure. If the same error occurs again even after measures have been taken against noise, the module may be in failure. Please consult your local Mitsubishi representative.
0107H	Moderate error	Restart not performed after safety module validation	The module has not been restarted after the safety module validation.	<ul style="list-style-type: none"> <li>Restart the safety remote I/O module. After the safety remote I/O module validation, safety communications can be established by restarting the module.</li> <li>If the same error occurs again even after the safety remote I/O module has been restarted in no error state, the module may be in failure. Please consult your local Mitsubishi representative.</li> </ul>
0201H	Minor error Restoration possible	Safety module validation not performed	The safety module validation has not been performed.	<ul style="list-style-type: none"> <li>Perform the safety module validation. After the safety module validation, safety communications can be established by restarting the module.</li> <li>If the same error occurs again even after "Safety module validation" is executed in no error state, the module may be in failure. Please consult your local Mitsubishi representative.</li> </ul>

Error code (hexadecimal)	Classification	Error name	Description and cause	Action
0202H	Minor error Restoration possible	Non-volatile memory data error (error history)	The error history data stored in the non-volatile memory is incorrect.	<ul style="list-style-type: none"> <li>The module will automatically recover immediately after the error occurs. Note that the error history of the errors that have occurred will be lost.</li> <li>If the same error occurs again, the module may be in failure. Please consult your local Mitsubishi representative.</li> </ul>
0203H <sup>1</sup>	Minor error Restoration possible	Remote buffer memory access error	An area outside the range of the remote buffer memory areas has been accessed using the REMFR/REMTO instructions.	<ul style="list-style-type: none"> <li>The module will automatically recover immediately after the error occurs.</li> <li>Correct the setting data of the REMFR/REMTO instruction to access the remote buffer memory.</li> </ul>
0204H	Minor error Restoration possible	Station number switch changed error	The station number setting switches have been changed with the module power-on.	The module will recover from this error by setting the switches to the previous station number that was set when the module power supply was powered on.
0205H <sup>1</sup>	Minor error Restoration possible	Double input discrepancy detection error	A double input discrepancy was detected in a pair of inputs (X0 and X1, X2 and X3, ...).	<ul style="list-style-type: none"> <li>Review the connected devices and wiring.</li> <li>When the connected devices and wiring have no errors, there may be an influence from noise or a hardware failure. Take measures to reduce noise.</li> <li>Power on the load power supply at the same timing of power-on of the module power supply.</li> <li>If the same error occurs again even after the measures have been taken, the module may be in failure. Please consult your local Mitsubishi representative.</li> <li>The module will recover from this error after the double input discrepancy is eliminated.</li> </ul>
0206H <sup>1</sup>	Minor error Restoration possible	Input dark test error	During an input dark test, test pulses were not detected.	<ul style="list-style-type: none"> <li>Review the connected devices and wiring.</li> <li>When the connected devices and wiring have no errors, there may be an influence from noise or a hardware failure. Take measures to reduce noise.</li> <li>Power on the load power supply at the same timing of power-on of the module power supply.</li> <li>If the same error occurs again even after the measures have been taken, the module may be in failure. Please consult your local Mitsubishi representative.</li> </ul>
0207H	Minor error Restoration possible	I/O data error	An error was detected by the I/O diagnostic.	<ul style="list-style-type: none"> <li>If double outputs are in discrepancy state, eliminate the error factor.</li> <li>Review the connected devices and wiring.</li> <li>When the connected devices and wiring have no errors, there may be an influence from noise or a hardware failure. Take measures to reduce noise.</li> <li>Power on the load power supply at the same timing of power-on of the module power supply.</li> <li>If the same error occurs again even after the measures have been taken, the module may be in failure. Please consult your local Mitsubishi representative.</li> </ul>
0208H <sup>1</sup>	Minor error Restoration possible	Output read-back error	A discrepancy of an output read-back value and an output value was detected.	<ul style="list-style-type: none"> <li>Review the connected devices and wiring.</li> <li>Check that 24V is supplied to the load power supply using a tester.</li> </ul>
0209H <sup>1</sup>	Minor error Restoration possible	Output dark test error	During an output dark test, test pulses were not detected.	<ul style="list-style-type: none"> <li>Check that the external connection is not overloaded.</li> <li>When the connected devices and wiring have no errors, there may be an influence from noise or a hardware failure. Take measures to reduce noise.</li> <li>Power on the load power supply at the same timing of power-on of the module power supply.</li> <li>If the same error occurs again even after the measures have been taken, the module may be in failure. Please consult your local Mitsubishi representative.</li> </ul>
020AH	Minor error	Access error when network parameters are invalid	An access error has occurred when network parameters are invalid.	Correctly set module parameters of the master station.

Error code (hexadecimal)	Classification	Error name	Description and cause	Action
020BH	Minor error	Safety module validation failure	The safety module validation failed.	<ul style="list-style-type: none"> <li>The module will automatically recover immediately after the error occurs.</li> <li>Check that no moderate error caused by the parameter setting has occurred on the module using the ERR. LED of the module and the error history. If an error has occurred, eliminate the cause.</li> <li>If the same error occurs again even after "Safety module validation" is executed in no error state, the module may be in failure. Please consult your local Mitsubishi representative.</li> </ul>
0500H	Moderate error Restoration possible	Parameter data error	An incorrect value or parameter data out of the range is set.	<ul style="list-style-type: none"> <li>Review the connected devices, wiring, and voltage.</li> <li>Correct the module parameter settings and module configuration.</li> <li>When the parameters are set again and the parameter setting has succeeded, the module will recover from this error.</li> </ul>

\*1 Detailed information of the error is stored in Error code details in Error history data. For Error code details, refer to the following.

 Page 98 Error code details

\*2 Restoration is possible only when the load power supply has a low-voltage error.

**Point** 

When multiple errors have occurred, only the latest error code is stored in Error code (RX10 to RX1F). The errors that occurred before can be checked by executing "Error history read" from the "Network Configuration Settings" in the engineering tool. For the error history, refer to the following.

 Page 83 Checking with "Command Execution of Slave Station"

## Error code details

Error details of the following error codes are stored in Error code details in Error history data.

### ■ Overload error (error code: 0102H)

A place where overcurrent was detected (in the module power supply or load power supply) is stored in Error code details 1.

b15	b14	b13	b12	b11	b10	b9	b8	b7	b6	b5	b4	b3	b2	b1	b0
0 (fixed)													(1)	(2)	

(1) 0: No error, 1: Overcurrent detected in the load power supply

(2) 0: No error, 1: Overcurrent detected in the module power supply

### ■ Power supply voltage error (error code: 0103H)

Information on the voltage error (whether the error has occurred in the module power supply or load power supply, whether it is an upper limit error or a lower limit error) is stored in Error code details 1.

b15	b14	b13	b12	b11	b10	b9	b8	b7	b6	b5	b4	b3	b2	b1	b0
0 (fixed)											(1)	(2)	(3)	(4)	

(1) 0: No error, 1: Load power supply voltage upper limit error

(2) 0: No error, 1: Load power supply voltage lower limit error

(3) 0: No error, 1: Module power supply voltage upper limit error

(4) 0: No error, 1: Module power supply voltage lower limit error

### ■ Remote buffer memory access error (error code: 0203H)

The start address of a remote buffer memory area that was accessed using the REMFR/REMT0 instruction is stored in Error code details 1. For details on the remote buffer memory addresses, refer to the following.

☞ Page 113 Remote Buffer Memory

- Error code details 1

b15	b14	b13	b12	b11	b10	b9	b8	b7	b6	b5	b4	b3	b2	b1	b0
Remote buffer memory address (16-bits)															

### ■ Double input discrepancy detection error (error code: 0205H)

When a double input discrepancy has occurred, a number corresponding to a pair of double input terminals with discrepancy is stored in Error code details 1.

- Error code details 1

b15	b14	b13	b12	b11	b10	b9	b8	b7	b6	b5	b4	b3	b2	b1	b0
0 (fixed)													(1)		

(1) 000: Discrepancy of X0 and X1, 001: Discrepancy of X2 and X3, 010: Discrepancy of X4 and X5, 011: Discrepancy of X6 and X7, 100: Discrepancy of X8 and X9, 101: Discrepancy of XA and XB

### ■ Input dark test error (error code: 0206H)

A number corresponding to an input terminal with the diagnostic error of input dark test is stored in Error code details 1.

- Error code details 1

b15	b14	b13	b12	b11	b10	b9	b8	b7	b6	b5	b4	b3	b2	b1	b0
0 (fixed)												(1)			

(1) A number corresponding to an input terminal with the error is stored.

0000: X0

0001: X1

0010: X2

0011: X3

0100: X4

0101: X5

0110: X6

0111: X7

1000: X8

1001: X9

1010: XA

1011: XB

### ■ I/O data error (error code: 0207H)

A number corresponding to an I/O terminal with the error is stored in Error code details 1.

- Error code details 1

b15	b14	b13	b12	b11	b10	b9	b8	b7	b6	b5	b4	b3	b2	b1	b0
0 (fixed)												(1)			

(1) A number corresponding to an I/O terminal with the error is stored.

0000: X0  
 0001: X1  
 0010: X2  
 0011: X3  
 0100: X4  
 0101: X5  
 0110: X6  
 0111: X7  
 1000: X8  
 1001: X9  
 1010: XA  
 1011: XB  
 1100: Y0 or Y0+  
 1101: Y1 or Y0-  
 1110: Y2 or Y1+  
 1111: Y3 or Y1-

### ■ Output read-back error (error code: 0208H)

A number corresponding to an output terminal with the output read-back error is stored in Error code details 1.

- Error code details 1

b15	b14	b13	b12	b11	b10	b9	b8	b7	b6	b5	b4	b3	b2	b1	b0
0 (fixed)												(1)			

(1) A number corresponding to an output terminal with the error is stored.

1100: Y0 or Y0+  
 1101: Y1 or Y0-  
 1110: Y2 or Y1+  
 1111: Y3 or Y1-

### ■ Output dark test error (error code: 0209H)

A number corresponding to an output terminal with the diagnostic error of output dark test is stored in Error code details 1.

- Error code details 1

b15	b14	b13	b12	b11	b10	b9	b8	b7	b6	b5	b4	b3	b2	b1	b0
0 (fixed)												(1)			

(1) A number corresponding to an output terminal with the error is stored.

1100: Y0 or Y0+  
 1101: Y1 or Y0-  
 1110: Y2 or Y1+  
 1111: Y3 or Y1-

### ■ Parameter data area (error code: 0500H)

The start address of the remote buffer memory of the parameter where an error was detected is stored in Error code details 1.

For details on the remote buffer memory addresses, refer to the following.

 Page 113 Remote Buffer Memory



- Error code details 1

b15	b14	b13	b12	b11	b10	b9	b8	b7	b6	b5	b4	b3	b2	b1	b0
Remote buffer memory address (16-bits)															

## Error codes related to CC-Link IE Field Network

This section describes CC-Link IE Field Network error codes. Communication errors refer to CC-Link IE Field Network communication related errors and safety communication related errors. The ERR. LED does not turn on when a communication error occurs.

Communication errors of CC-Link IE Field Network are classified into the following two error types depending on the operation of the D LINK LED performed at an error, and troubleshooting differs for each error type.

-  Page 100 Communication errors where the D LINK LED flashes or turns off
-  Page 101 Communication errors where the D LINK LED does not change

### Communication errors where the D LINK LED flashes or turns off

The following table lists the communication errors of CC-Link IE Field Network where the D LINK LED flashes or turns off at an error. Troubleshoot these errors with the CC-Link IE Field Network diagnostics of the engineering tool.

Error code (hexadecimal)	Classification	Error name	Description and cause	Action
D0E0H	Communication error	Station type mismatch	The module parameter of the master station is incorrect or outside the range.	Change the station type of the module to the remote device station in the "Network Configuration Settings" of the master station.
D0E1H	Communication error	Own station reserved	The module parameter of the master station is incorrect or outside the range.	<ul style="list-style-type: none"><li>• In the "Network Configuration Settings" of the master station, cancel the reserved station specification.</li><li>• Change the station number of the module to a station number that is not reserved.</li></ul>
D0E2H	Communication error	Station No. already in use (own station)	The station number setting switch is incorrect.	<ul style="list-style-type: none"><li>• Set a unique station number.</li><li>• After taking the above action, power off and on or reset all the stations where this error was detected.</li></ul>
D0E3H	Communication error	Own station No. out of range	The module parameter of the master station is incorrect or outside the range.	Add the station information of the module in the "Network Configuration Settings" of the master station.
D72AH	Communication error	Station number switch out of range	A station number out of range (a value other than 1 to 120) has been set.	Set the station number within the allowable range.

## Communication errors where the D LINK LED does not change

The following table lists the communication errors of CC-Link IE Field Network where the D LINK LED does not change at an error. These errors are automatically eliminated after occurrence of an error. Therefore, they are not displayed in the CC-Link IE Field Network diagnostics of the engineering tool. Troubleshoot these errors by executing "Error history read" from the "Network Configuration Settings".

Error code (hexadecimal)	Classification	Error name	Description and cause	Action
D217H	Communication error	Transient data command error	The transient data request command is incorrect.	Correct the request command at the request source, and send the data again.
D2A0H	Communication error	Receive buffer full	The target station is overloaded and cannot receive transient data.	<ul style="list-style-type: none"> <li>• Check the network status using CC-Link IE Field Network diagnostics of the engineering tool to take the appropriate action.</li> <li>• When the target station is overloaded and cannot receive transient data, send the data to the target station after a while.</li> </ul>
D2A3H	Communication error	Transient data length error	The received transient data is incorrect.	Correct the number of data (frame length) at the request source, and send the data again.
DF01H	Communication error	Transient data divided error	The divided transient data have been received.	Send the transient data that is not divided.

### Point

- When multiple errors have occurred, only the latest error code is stored in Error code (RX10 to RX1F). The errors that occurred before can be checked by executing "Error history read" from the "Network Configuration Settings". For the error history, refer to the following.

 Page 83 Checking with "Command Execution of Slave Station"

- Error code details 1 to Error code details 10 for communication errors are fixed to 0.

## Error codes related to safety communication

The following table lists safety communication error codes.

The ERR. LED does not turn on when a communication error related to the safety communication occurs, the same as a case when a communication error of CC-Link IE Field Network occurs. When an error occurs, the SAFETY LED turns off and the D LINK LED does not change.

Error code (hexadecimal)	Classification	Error name	Description and cause	Action
8400H	Communication error	Safety communication error	An error was detected in the safety communication with the master station.	<ul style="list-style-type: none"> <li>Refer to the following and set module parameters and perform the safety module validation according to the parameter setting procedure. <ul style="list-style-type: none"> <li>Page 67 Module parameter setting procedure</li> </ul> </li> <li>When the parameter setting has no errors, there may be an influence from noise or a hardware failure. If the same error occurs again even after measures have been taken against noise, the module may be in failure. Please consult your local Mitsubishi representative.</li> </ul>
8401H	Communication error	Safety communication disabled due to a communication interrupt	A communication interrupt has occurred on CC-Link IE Field Network and the safety communication is stopped.	<ul style="list-style-type: none"> <li>Check the network status using the CC-Link IE Field Network diagnostics of the engineering tool for errors.</li> <li>When no error has occurred on the network, there may be an influence from noise or a hardware failure. If the same error occurs again even after measures have been taken against noise, the module may be in failure. Please consult your local Mitsubishi representative.</li> </ul>
8402H	Communication error	Safety communication connection being established Response monitoring timeout	Response monitoring timeout was detected while the safety connection was being established in the safety communication with the master station.	<ul style="list-style-type: none"> <li>Correct "Transmission interval monitoring time" of the module parameter as well as "Safety Communication Setting" of the master station. After that, refer to the following and set module parameters and perform the safety module validation according to the parameter setting procedure. <ul style="list-style-type: none"> <li>Page 67 Module parameter setting procedure</li> </ul> </li> <li>When the parameter setting has no errors, there may be an influence from noise or a hardware failure. If the same error occurs again even after measures have been taken against noise, the module may be in failure. Please consult your local Mitsubishi representative.</li> </ul>
8403H	Communication error	Safety communication being refreshed Response monitoring timeout	Response monitoring timeout was detected while the safety communication was being refreshed in the safety communication with the master station.	<ul style="list-style-type: none"> <li>Correct "Transmission interval monitoring time" of the module parameter as well as "Safety Communication Setting" of the master station. After that, refer to the following and set module parameters and perform the safety module validation according to the parameter setting procedure. <ul style="list-style-type: none"> <li>Page 67 Module parameter setting procedure</li> </ul> </li> <li>When the parameter setting has no errors, there may be an influence from noise or a hardware failure. If the same error occurs again even after measures have been taken against noise, the module may be in failure. Please consult your local Mitsubishi representative.</li> </ul>
8404H	Communication error	Safety communication error in processing Response monitoring timeout	Response monitoring timeout was detected while a safety communication error was being processed in the safety communication with the master station.	<ul style="list-style-type: none"> <li>Correct "Transmission interval monitoring time" of the module parameter as well as "Safety Communication Setting" of the master station. After that, refer to the following and set module parameters and perform the safety module validation according to the parameter setting procedure. <ul style="list-style-type: none"> <li>Page 67 Module parameter setting procedure</li> </ul> </li> <li>When the parameter setting has no errors, there may be an influence from noise or a hardware failure. If the same error occurs again even after measures have been taken against noise, the module may be in failure. Please consult your local Mitsubishi representative.</li> </ul>



Error code (hexadecimal)	Classification	Error name	Description and cause	Action
8405H	Communication error	Safety communication receiving interval monitoring timeout	Receiving interval monitoring timeout was detected in the safety communication with the master station.	<ul style="list-style-type: none"> <li>Correct "Transmission interval monitoring time" of the module parameter as well as "Safety Communication Setting" of the master station. After that, refer to the following and set module parameters and perform the safety module validation according to the parameter setting procedure.</li> <li>☞ Page 67 Module parameter setting procedure</li> <li>Check that the Ethernet cables are not disconnected or cables are not cut off during safety communication.</li> <li>When the parameter setting has no errors, there may be an influence from noise or a hardware failure. If the same error occurs again even after measures have been taken against noise, the module may be in failure. Please consult your local Mitsubishi representative.</li> </ul>
8406H	Communication error	Safety communication receive data delay detection	Unacceptable delay was detected in the analysis of the data received from the master station.	<ul style="list-style-type: none"> <li>Correct "Transmission interval monitoring time" of the module parameter as well as "Safety Communication Setting" of the master station. After that, refer to the following and set module parameters and perform the safety module validation according to the parameter setting procedure.</li> <li>☞ Page 67 Module parameter setting procedure</li> <li>When the parameter setting has no errors, there may be an influence from noise or a hardware failure. If the same error occurs again even after measures have been taken against noise, the module may be in failure. Please consult your local Mitsubishi representative.</li> </ul>
8407H	Communication error	Safety communication receive data loss detection	A loss was detected in the analysis of the data received from the master station.	

# APPENDICES

## Appendix 1 Safety Remote I/O Signals

Safety remote I/O signals are dedicated for safety control and are assigned to the safety device of the master station. This appendix lists the safety remote I/O signals for a Safety CPU.

Item	Description
Safety remote input (SAIX)	Safety input signals from the safety remote I/O module to the Safety CPU
Safety remote output (SAIY)	Safety output signals from the Safety CPU to the safety remote I/O module



For details on the safety device, refer to the following.

MELSEC iQ-R CPU Module User's Manual (Application)

### Assignment of safety remote I/O signals

Safety remote input (SAIX)	Description	Safety remote output (SAIY)	Description
SAIX0 to SAIXB	Safety input signal	SAIY0 to SAIY3	Safety output signal
SAIXC to SAIX17	Safety input status		
SAIX18 to SAIX1B	Safety output status		

# Lists of safety remote I/O signals

## List of NZ2GFS12A2-16DTE safety remote I/O module signals

Safety remote input (SAIX)		Safety remote output (SAIY)	
Signal direction: Safety remote I/O module → Master/local module		Signal direction: Master/local module → Safety remote I/O module	
Device No.	Name	Device No.	Name
SAIX0	Safety input signal X0	SAIY0	Safety output signal Y0
SAIX1	Safety input signal X1	SAIY1	Safety output signal Y1
SAIX2	Safety input signal X2	SAIY2	Safety output signal Y2
SAIX3	Safety input signal X3	SAIY3	Safety output signal Y3
SAIX4	Safety input signal X4	—	
SAIX5	Safety input signal X5		
SAIX6	Safety input signal X6		
SAIX7	Safety input signal X7		
SAIX8	Safety input signal X8		
SAIX9	Safety input signal X9		
SAIXA	Safety input signal XA		
SAIXB	Safety input signal XB		
SAIXC	Safety input status X0		
SAIXD	Safety input status X1		
SAIXE	Safety input status X2		
SAIXF	Safety input status X3		
SAIX10	Safety input status X4		
SAIX11	Safety input status X5		
SAIX12	Safety input status X6		
SAIX13	Safety input status X7		
SAIX14	Safety input status X8		
SAIX15	Safety input status X9		
SAIX16	Safety input status XA		
SAIX17	Safety input status XB		
SAIX18	Safety output status Y0		
SAIX19	Safety output status Y1		
SAIX1A	Safety output status Y2		
SAIX1B	Safety output status Y3		



## List of NZ2GFS12A2-14DT safety remote I/O module signals

Safety remote input (SAIX)		Safety remote output (SAIY)	
Signal direction: Safety remote I/O module → Master/local module		Signal direction: Master/local module → Safety remote I/O module	
Device No.	Name	Device No.	Name
SAIX0	Safety input signal X0	SAIY0	Safety output signal Y0+
SAIX1	Safety input signal X1	SAIY1	Safety output signal Y0-
SAIX2	Safety input signal X2	SAIY2	Safety output signal Y1+
SAIX3	Safety input signal X3	SAIY3	Safety output signal Y1-
SAIX4	Safety input signal X4	—	
SAIX5	Safety input signal X5		
SAIX6	Safety input signal X6		
SAIX7	Safety input signal X7		
SAIX8	Safety input signal X8		
SAIX9	Safety input signal X9		
SAIXA	Safety input signal XA		
SAIXB	Safety input signal XB		
SAIXC	Safety input status X0		
SAIXD	Safety input status X1		
SAIXE	Safety input status X2		
SAIXF	Safety input status X3		
SAIX10	Safety input status X4		
SAIX11	Safety input status X5		
SAIX12	Safety input status X6		
SAIX13	Safety input status X7		
SAIX14	Safety input status X8		
SAIX15	Safety input status X9		
SAIX16	Safety input status XA		
SAIX17	Safety input status XB		
SAIX18	Safety output status Y0+		
SAIX19	Safety output status Y0-		
SAIX1A	Safety output status Y1+		
SAIX1B	Safety output status Y1-		



For details on safety remote I/O signals, refer to the following.

Page 107 Safety Remote I/O Signals

# Details of safety remote I/O signals

## Safety input signals

### ■ Safety input signal X□ (SAIX0 to SAIXB)

These signals indicate the ON/OFF state of safety remote input (SAIX) due to the external input signals (X0 to XB) of the safety remote I/O module.

However, when the double wiring function and the noise removal filter function are enabled, the ON/OFF state of the safety input signals X□ (SAIX0 to SAIXB) and that of the actual external input signals (X0 to XB) may differ. For details on the safety I/O function, refer to the following.

☞ Page 28 I/O functions

## Safety input status

### ■ Safety input status X□ (SAIXC to SAIX17)

These signals store the safety input status. The safety input status is ON when the corresponding input signal is operating normally. The safety input status is OFF when an error was detected in the corresponding input signal. For details on the safety input status, refer to the following.

☞ Page 47 Combination of double inputs

## Safety output status

### ■ Safety output status Y□ (SAIX18 to SAIX1B)

These signals indicate the ON/OFF state of the external output terminals.

They can be used to monitor the actual signals of the external output. For details on the safety output status, refer to the following.

☞ Page 51 Combination of double outputs

## Safety output signal

### ■ Safety output signal Y□ (SAIY0 to SAIY3)

These signals turn on or off each of the external outputs (Y0 to Y3) of the safety remote I/O module.

When the double wiring function is enabled, the ON/OFF state of the safety output signals Y□ (SAIY0 to SAIY3) and that of the actual external outputs (Y0 to Y3) may differ. For details on the safety I/O function, refer to the following.

☞ Page 28 I/O functions

# Appendix 2 Remote I/O Signals

This appendix lists the remote I/O signals for a master/local module.

The following shows an assignment example of I/O signals with the remote I/O signals of the safety remote I/O module assigned to the I/O numbers of RX0 to RX4F and RY0 to RY4F.

Remote input (RX) are input signals from the safety remote I/O module to the master/local module.

Remote output (RY) are output signals from the master/local module to the safety remote I/O module.

The remote I/O signals of the safety remote I/O module are assigned as shown below.

Module	Remote input (RX)	Remote output (RY)
Safety remote I/O module	RX0 to RX4F	RY0 to RY4F

**Point** 

- These signals (RX/RX) are used to control and monitor functions other than the safety functions of the safety remote I/O module.
- The external I/O signals of the safety remote I/O module are communicated to the master/local module using the "safety remote I/O signals (SA\X and SA\Y)".
- Do not use these signals in a program that operates the safety functions. If any of the signals is used, the correct operation of the safety functions of the module cannot be guaranteed.
- When "Link Stop" is performed using the CC-Link IE Field diagnostics and the cyclic transmission is stopped from the link special relay (SB) or link special register, the input status of RX is held, and thus the status may differ from the actual status of the module.

## List of remote I/O signals

The remote I/O signals of the safety remote I/O module are assigned as shown below.

Remote input		Remote output	
Signal direction: Safety remote I/O module → Master/local module		Signal direction: Master/local module → Safety remote I/O module	
Device No.	Description	Device No.	Description
RX0 to RXF	Module status area	RY0 to RYF	Use prohibited
RX10 to RX1F	Error code	RY10 to RY1F	
RX20 to RX2F	Warning code	RY20 to RY2F	
RX30 to RX3B	External input monitor	RY30 to RY3B	
RX3C to RX3F	Use prohibited	RY3C to RY3F	
RX40 to RX45	Power supply monitor	RY40 to RY45	
RX46 to RX4F	Use prohibited	RY46 to RY4F	

**Point** 

Do not use any "Use prohibited" remote I/O signals. Doing so may cause an accident due to incorrect output or malfunction.

# Details of remote I/O signals

## Module status area (RX0 to RXF)

These areas display the status of modules, each as a remote device station.

Module operation is not possible from these areas.

The module status areas are assigned as follows.

Module status area	
Device No.	Description
RX0	Use prohibited
RX1	
RX2	
RX3	
RX4	
RX5	
RX6	
RX7	Warning status flag
RX8	Use prohibited
RX9	
RXA	Error status flag
RXB	Remote READY
RXC	Use prohibited
RXD	
RXE	
RXF	

## Warning status flag (RX7)

Warning status flag (RX7) turns on when a minor error occurs.

Five seconds after the cause of the minor error is eliminated, 0000H is automatically stored in Warning code (RX20 to RX2F), and simultaneously Warning status flag (RX7) turns off.

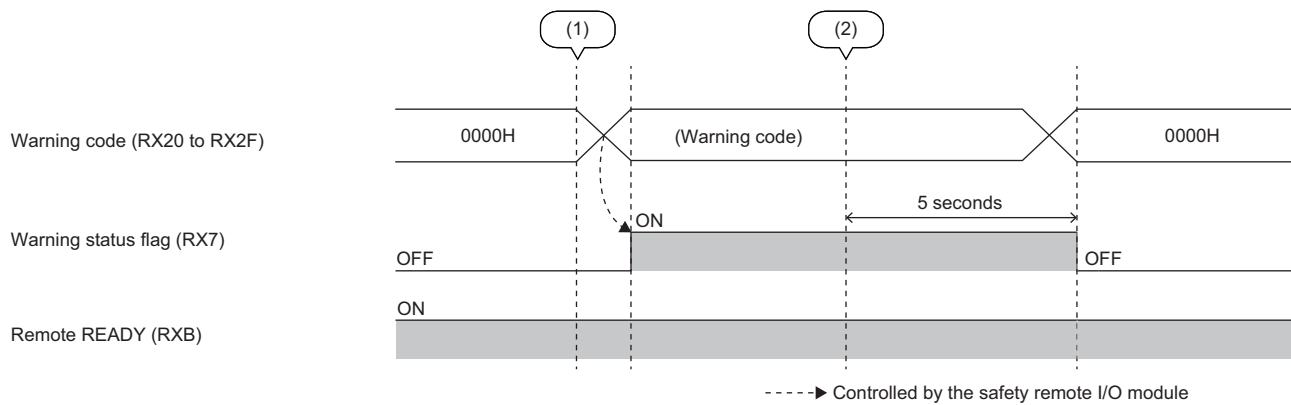

(1) A minor error occurs.

(2) The minor error is cleared.

A

## Error status flag (RXA)

Error status flag (RXA) turns on when a moderate error or major error occurs.

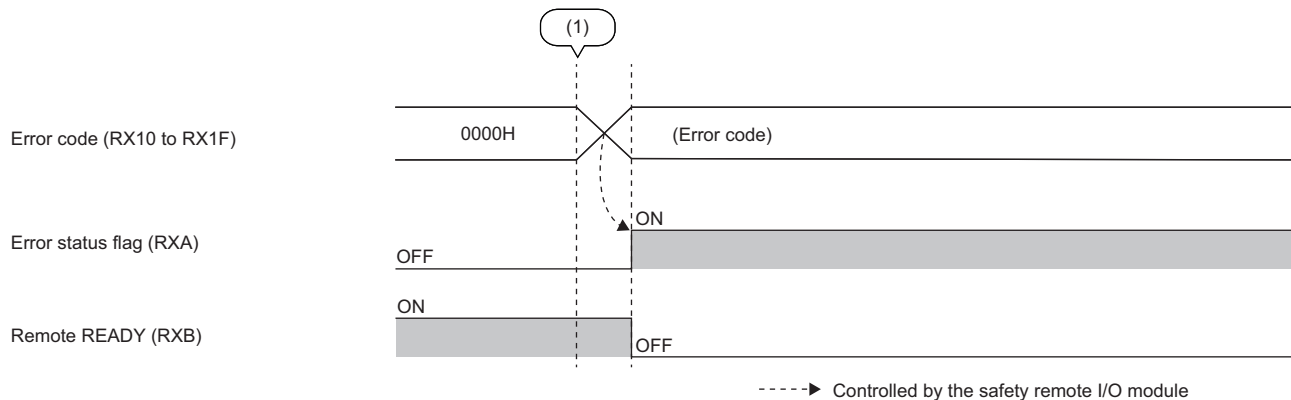

(1) An error occurs.

### Point

When a moderate error or major error occurs, the error cannot be cleared until the cause of the error is eliminated and the safety remote I/O module is restarted (by powering off and on the module or performing remote reset).

## Remote READY (RXB)

This signal is used as an interlock condition when the master station reads/writes data from/to the remote I/O signals or remote buffer memory areas of the safety remote I/O module.

The module operating status is listed in the following table.

Remote READY (RXB) status	Module operating status
OFF	Module operation disabled (The external I/O cannot be updated.)
ON	Module operation enabled (The external I/O can be updated.)

When the initial processing is completed after the module power supply is powered on, Remote READY (RXB) turns on. When Error status flag (RXA) turns on, Remote READY (RXB) turns off.

## Error code (RX10 to RX1F)

An error code is stored when a moderate error or major error occurs.

Errors that occurred in the past can be checked with Error history area (address: 0A00H to 0FFFH).

For details on the error history, refer to the following.

☞ Page 122 Error history data

## Warning code (RX20 to RX2F)

The error code is stored when a minor error occurs.

Errors that occurred in the past can be checked with Error history area (address: 0A00H to 0FFFH).

For details on the error history, refer to the following.

☞ Page 122 Error history data



## External input monitor (RX30 to RX3F)

These signals indicate the ON/OFF state of the external input terminals. By monitoring the actual signals of the external input, a double input discrepancy detection error can be troubleshooted easily when it occurs. All the input signals turn off in the modes other than the safety drive mode, so all the signal statuses also turn OFF.

This area is assigned as follows.

Device No.	Name
RX30	External input monitor X0
RX31	External input monitor X1
RX32	External input monitor X2
RX33	External input monitor X3
RX34	External input monitor X4
RX35	External input monitor X5
RX36	External input monitor X6
RX37	External input monitor X7
RX38	External input monitor X8
RX39	External input monitor X9
RX3A	External input monitor XA
RX3B	External input monitor XB
RX3C to RX3F	Use prohibited

## Power supply monitor (RX40 to RX45)

These signals turn on when overvoltage or overcurrent has occurred in the module power supply or load power supply.

This area is assigned as follows.

Device No.	Name
RX40	Lower limit of Module/Input power supply
RX41	Over limit of Module/Input power supply
RX42	Lower limit of Load/Output power supply
RX43	Over limit of Load/Output power supply
RX44	Over current indication of Module/Input power supply
RX45	Over current indication of Load/Output power supply

A

# Appendix 3 Remote Register

---





The safety remote I/O modules use the remote register areas for the safety communication. Therefore, always assign the following points.

Item	Description
RWr/RWw points	16 points

All areas of the remote register (RWr/RWw) are use-prohibited areas. Do not read or write data from/to the use-prohibited areas. If data is read or written from/to any of the use-prohibited areas, the correct operation of the module cannot be guaranteed.

# Appendix 4 Remote Buffer Memory

The remote buffer memory areas are classified into the following four area types.

- Parameter area: Sets the parameters of the module.  
 Page 114 Parameter area (address: 0000H to 04FFH)
- Monitoring area: Stores the current module status.  
 Page 115 Monitoring area (address: 0500H to 09FFH)
- Error history area: Stores the history of errors detected by the module.  
 Page 116 Error history area (address: 0A00H to 0FFFH)
- Module control data area: Used for controlling the module.  
 Page 117 Module control data area (address: 1000H to 14FFH)

## Assignment of remote buffer memory areas

○: Available, ×: Not available

Address		Area	Type		Access method				
Decimal	Hexadecimal				CC IE Field configuration of the engineering tool	REMFR instruction, REMTO instruction <sup>*1</sup>			
0 to 255	0000H to 00FFH	Parameter area	Parameter data per station		○	○			
256 to 511	0100H to 01FFH		Parameter data per module	Safety remote I/O module					
512 to 767	0200H to 02FFH			System area			×	×	
768 to 1023	0300H to 03FFH			System area					
1024 to 1279	0400H to 04FFH			System area					
1280 to 1535	0500H to 05FFH	Monitoring area	Monitor data per station		×	×			
1536 to 1791	0600H to 06FFH		Monitor data per module	Safety remote I/O module					
1792 to 2047	0700H to 07FFH			System area					
2048 to 2303	0800H to 08FFH			System area					
2304 to 2559	0900H to 09FFH			System area					
2560 to 4095	0A00H to 0FFFH	Error history area	Error history data		○ <sup>*2</sup>	○			
4096 to 4351	1000H to 10FFH	Module control data area	Control data per station		×	○			
4352 to 4607	1100H to 11FFH		Control data per module	Safety remote I/O module					
4608 to 4863	1200H to 12FFH			System area			×		
4864 to 5119	1300H to 13FFH			System area					
5120 to 5375	1400H to 14FFH			System area					
5376 to 65535	1500H to FFFFH	System area			×	×			

\*1 For the REMFR and REMTO instructions, refer to the following.  
 MELSEC iQ-R Programming Manual (Module Dedicated Instructions)

\*2 For the access method, refer to the following.  
 Page 83 Checking with "Command Execution of Slave Station"

### Point

- Do not write to the system area. Doing so may cause an accident due to incorrect output or malfunction.
- Do not access the system area by using the REMFR or REMTO instruction.



# Lists of remote buffer memory areas

## Parameter area (address: 0000H to 04FFH)

### ■ Safety remote I/O module

R: Can be read from a program, W: Can be written from a program

Address		Safety remote I/O module		Read/Write
Decimal	Hexadecimal	Name		
		NZ2GFS12A2-16DTE	NZ2GFS12A2-14DT	
0	0H	Transmission interval monitoring time		R
1 to 255	0001H to 00FFH	System area		—
256	0100H	Input test pulse setting X0/X1		R
257	0101H	Input test pulse setting X2/X3		R
258	0102H	Input test pulse setting X4/X5		R
259	0103H	Input test pulse setting X6/X7		R
260	0104H	Input test pulse setting X8/X9		R
261	0105H	Input test pulse setting XA/XB		R
262	0106H	Output mode setting Y0/Output dark test pulse time Y0	Output mode setting Y0+/Output dark test pulse time Y0	R
263	0107H	Output mode setting Y1/Output dark test pulse time Y1	Output mode setting Y0-/System area	R
264	0108H	Output mode setting Y2/Output dark test pulse time Y2	Output mode setting Y1+/Output dark test pulse time Y1	R
265	0109H	Output mode setting Y3/Output dark test pulse time Y3	Output mode setting Y1-/System area	R
266	010AH	Wiring selection of output	System area	R
267	010BH	Input ON delay X0		R
268	010CH	Input OFF delay X0		R
269	010DH	Input mode setting X0		R
270	010EH	Input ON delay X1		R
271	010FH	Input OFF delay X1		R
272	0110H	Input mode setting X1		R
273	0111H	Input ON delay X2		R
274	0112H	Input OFF delay X2		R
275	0113H	Input mode setting X2		R
276	0114H	Input ON delay X3		R
277	0115H	Input OFF delay X3		R
278	0116H	Input mode setting X3		R
279	0117H	Input ON delay X4		R
280	0118H	Input OFF delay X4		R
281	0119H	Input mode setting X4		R
282	011AH	Input ON delay X5		R
283	011BH	Input OFF delay X5		R
284	011CH	Input mode setting X5		R
285	011DH	Input ON delay X6		R
286	011EH	Input OFF delay X6		R
287	011FH	Input mode setting X6		R
288	0120H	Input ON delay X7		R
289	0121H	Input OFF delay X7		R
290	0122H	Input mode setting X7		R
291	0123H	Input ON delay X8		R
292	0124H	Input OFF delay X8		R
293	0125H	Input mode setting X8		R
294	0126H	Input ON delay X9		R

Address		Safety remote I/O module		Read/Write
Decimal	Hexadecimal	Name		
		NZ2GFS12A2-16DTE	NZ2GFS12A2-14DT	
295	0127H	Input OFF delay X9		R
296	0128H	Input mode setting X9		R
297	0129H	Input ON delay XA		R
298	012AH	Input OFF delay XA		R
299	012BH	Input mode setting XA		R
300	012CH	Input ON delay XB		R
301	012DH	Input OFF delay XB		R
302	012EH	Input mode setting XB		R
303	012FH	Wiring selection of input X0/X1		R
304	0130H	Double input discrepancy detection time X0/X1		R
305	0131H	Wiring selection of input X2/X3		R
306	0132H	Double input discrepancy detection time X2/X3		R
307	0133H	Wiring selection of input X4/X5		R
308	0134H	Double input discrepancy detection time X4/X5		R
309	0135H	Wiring selection of input X6/X7		R
310	0136H	Double input discrepancy detection time X6/X7		R
311	0137H	Wiring selection of input X8/X9		R
312	0138H	Double input discrepancy detection time X8/X9		R
313	0139H	Wiring selection of input XA/XB		R
314	013AH	Double input discrepancy detection time XA/XB		R
315 to 1279	013BH to 04FFH	System area		—



Set the parameter areas from the "Parameter Processing of Slave Station" window of the engineering tool. The parameter areas cannot be set from a program.

A

## Monitoring area (address: 0500H to 09FFH)

### ■ Safety remote I/O module

R: Can be read from a program, W: Can be written from a program

Type	Address		Safety remote I/O module	Read/Write
	Decimal	Hexadecimal	Name	
Monitor data per station	1280 to 1535	0500H to 05FFH	System area	—
Monitor data per module	1536 to 1791	0600H to 06FFH	System area	—
System area	1792 to 2559	0700H to 09FFH	System area	—



Default values are not determined in the monitoring areas.

## Error history area (address: 0A00H to 0FFFH)

### ■ Safety remote I/O module

R: Can be read from a program, W: Can be written from a program

Address		Safety remote I/O module		Default value <sup>*1</sup>	Read/Write
Decimal	Hexadecimal	Name			
2560	0A00H	Error history data 1	Error code	0000H	R
2561	0A01H		Order of generation	0000H	R
2562	0A02H		[Error time] First two digits of the year/Last two digits of the year	0000H	R
2563	0A03H		[Error time] Month/Day	0000H	R
2564	0A04H		[Error time] Hour/Minute	0000H	R
2565	0A05H		[Error time] Second/00H (Fixed)	0000H	R
2566	0A06H		Error code details 1	0000H	R
2567	0A07H		Error code details 2	0000H	R
2568	0A08H		Error code details 3	0000H	R
2569	0A09H		Error code details 4	0000H	R
2570	0A0AH		Error code details 5	0000H	R
2571	0A0BH		Error code details 6	0000H	R
2572	0A0CH		Error code details 7	0000H	R
2573	0A0DH		Error code details 8	0000H	R
2574	0A0EH		Error code details 9	0000H	R
2575	0A0FH	Error code details 10	0000H	R	
2576 to 2591	0A10H to 0A1FH	Error history data 2	Same as Error history data 1.		
2592 to 2607	0A20H to 0A2FH	Error history data 3	Same as Error history data 1.		
2608 to 2623	0A30H to 0A3FH	Error history data 4	Same as Error history data 1.		
2624 to 2639	0A40H to 0A4FH	Error history data 5	Same as Error history data 1.		
2640 to 2655	0A50H to 0A5FH	Error history data 6	Same as Error history data 1.		
2656 to 2671	0A60H to 0A6FH	Error history data 7	Same as Error history data 1.		
2672 to 2687	0A70H to 0A7FH	Error history data 8	Same as Error history data 1.		
2688 to 2703	0A80H to 0A8FH	Error history data 9	Same as Error history data 1.		
2704 to 2719	0A90H to 0A9FH	Error history data 10	Same as Error history data 1.		
2720 to 2735	0AA0H to 0AAFH	Error history data 11	Same as Error history data 1.		
2736 to 2751	0AB0H to 0ABFH	Error history data 12	Same as Error history data 1.		
2752 to 2767	0AC0H to 0ACFH	Error history data 13	Same as Error history data 1.		
2768 to 2783	0AD0H to 0ADFH	Error history data 14	Same as Error history data 1.		
2784 to 2799	0AE0H to 0AEFH	Error history data 15	Same as Error history data 1.		
2800 to 4095	0AF0H to 0FFFH	System area		—	—

\*1 The factory default value or the value initialized by using Error history clear command (address: 1000H)

## Module control data area (address: 1000H to 14FFH)

### ■ Safety remote I/O module

R: Can be read from a program, W: Can be written from a program

Type	Address		Safety remote I/O module	Default value <sup>*1</sup>	Read/Write
	Decimal	Hexadecimal	Name		
Control data per station	4096	1000H	Error history clear command	0000H	R/W
	4097	1001H	Error history clear completed	0000H	R
	4098	1002H	Parameter area initialization command	0000H	R/W
	4099	1003H	Parameter area initialization completed	0000H	R
	4100	1004H	System area	—	—
	4101	1005H	Safety module enabled flag	0000H	R
	4102 to 4351	1006H to 10FFH	System area	—	—
Control data per module	4352 to 5375	1100H to 14FFH	System area	—	—

\*1 This is the value for when the module power supply is turned off and on or at the remote reset.

## Details of remote buffer memory areas

This section describes the details of remote buffer memory areas of the safety remote I/O module.

### Transmission interval monitoring time

Set the safety input data transmission interval time of the safety remote I/O module for each module. This time is to be monitored by the master station. Settings are done in units of words.

#### ■Setting specifications

Address	Name	Setting range
0000H	Transmission interval monitoring time	10 to 1000 (ms) (default value: 35)



Set the transmission interval monitoring time in the safety remote I/O module to a value (unit: ms) that satisfies all of the following conditions.

- $TM \geq SRref \times 2$
- $TM \geq SCmst \times 2 + LS \times 2$

SRref: Safety remote station refresh response processing time

TM: Transmission interval monitoring time

SCmst: Safety cycle time of the master station

LS: Link scan time

For the setting values of "Sending Interval Monitoring Time" and "Safety Refresh Monitoring Time" for the master module, refer to the following.

User's manual for the master/local module used

### Input test pulse setting

Set the output setting for the test pulse terminals (T0 to TB) of the safety remote I/O module in increments of one point. To execute the input dark test, set "Input test pulse setting" to "1: With test pulse".

Address	Name (H)	Name (L)	Setting range												
0100H	Input test pulse setting X1	Input test pulse setting X0	1: With test pulse 2: Without test pulse (default)												
0101H	Input test pulse setting X3	Input test pulse setting X2													
0102H	Input test pulse setting X5	Input test pulse setting X4													
0103H	Input test pulse setting X7	Input test pulse setting X6													
0104H	Input test pulse setting X9	Input test pulse setting X8													
0105H	Input test pulse setting XB	Input test pulse setting XA													
<b>b15</b>	<b>b14</b>	<b>b13</b>	<b>b12</b>	<b>b11</b>	<b>b10</b>	<b>b9</b>	<b>b8</b>	<b>b7</b>	<b>b6</b>	<b>b5</b>	<b>b4</b>	<b>b3</b>	<b>b2</b>	<b>b1</b>	<b>b0</b>
Input test pulse setting X1/X3/X5/X7/X9/XB								Input test pulse setting X0/X2/X4/X6/X8/XA							



- When "Wiring selection of input" is set to "1: Double wiring (NC/NC)" or "2: Double wiring (NC/NO)", set the same value as  $X_{n+1}$  for  $X_n$  ( $n$ : even number).
- When "Input mode setting" is set to "2: Input dark test execution", set "Input test pulse setting" to "1: With test pulse".



## Output mode setting/Output dark test pulse time

Set the output setting of the safety remote I/O module in increments of one point. Also, when performing the output dark test, set the pulse time for the output dark test. When "Output mode setting" is set to a value other than "2: Output dark test execution", the setting value of the output dark test pulse time is ignored.

### ■Setting specifications (NZ2GFS12A2-16DTE)

Address	Name (H)	Name (L)	Setting range												
0106H	Output dark test pulse time Y0	Output mode setting Y0	<ul style="list-style-type: none"> <li>Output mode setting</li> <li>1: Not used (default)</li> <li>2: Output dark test execution</li> <li>3: Output dark test non-execution</li> <li>Output dark test pulse time</li> <li>3 to 100 (<math>\times 100\mu\text{s}</math>) (default value: 7)</li> </ul>												
0107H	Output dark test pulse time Y1	Output mode setting Y1													
0108H	Output dark test pulse time Y2	Output mode setting Y2													
0109H	Output dark test pulse time Y3	Output mode setting Y3													
<b>b15</b>	<b>b14</b>	<b>b13</b>	<b>b12</b>	<b>b11</b>	<b>b10</b>	<b>b9</b>	<b>b8</b>	<b>b7</b>	<b>b6</b>	<b>b5</b>	<b>b4</b>	<b>b3</b>	<b>b2</b>	<b>b1</b>	<b>b0</b>
Output dark test pulse time Y0/Y1/Y2/Y3								Output mode setting Y0/Y1/Y2/Y3							

### ■Setting specifications (NZ2GFS12A2-14DT)

Address	Name (H)	Name (L)	Setting range												
0106H	Output dark test pulse time Y0	Output mode setting Y0+	<ul style="list-style-type: none"> <li>Output mode setting</li> <li>1: Not used (default)</li> <li>2: Output dark test execution</li> <li>3: Output dark test non-execution</li> <li>Output dark test pulse time</li> <li>3 to 100 (<math>\times 100\mu\text{s}</math>) (default value: 7)</li> </ul>												
0107H	—	Output mode setting Y0-													
0108H	Output dark test pulse time Y1	Output mode setting Y1+													
0109H	—	Output mode setting Y1-													
<b>b15</b>	<b>b14</b>	<b>b13</b>	<b>b12</b>	<b>b11</b>	<b>b10</b>	<b>b9</b>	<b>b8</b>	<b>b7</b>	<b>b6</b>	<b>b5</b>	<b>b4</b>	<b>b3</b>	<b>b2</b>	<b>b1</b>	<b>b0</b>
Output dark test pulse time Y0/Y1								Output mode setting Y0+/Y0-/Y1+/Y1-							

#### Point

- When "Wiring selection of output" is set to "1: Double wiring", the setting value for  $Y_{n+1}$  ( $n$ : even number) is ignored.
- For unused output terminals, set "Output mode setting" to "1: Not used".
- When a setting other than "2: Output dark test execution" is selected, the setting value of the output dark test pulse time is ignored.

## Wiring selection of output

Set the wiring selection of output in increments of one point.

### ■Setting specifications (NZ2GFS12A2-16DTE)

Address	Name (H)	Name (L)	Setting range												
010AH	Wiring selection of output Y2/Y3	Wiring selection of output Y0/Y1	1: Double wiring (default) 2: Single wiring												
<b>b15</b>	<b>b14</b>	<b>b13</b>	<b>b12</b>	<b>b11</b>	<b>b10</b>	<b>b9</b>	<b>b8</b>	<b>b7</b>	<b>b6</b>	<b>b5</b>	<b>b4</b>	<b>b3</b>	<b>b2</b>	<b>b1</b>	<b>b0</b>
Wiring selection of output Y2/Y3								Wiring selection of output Y0/Y1							

### ■Setting specifications (NZ2GFS12A2-14DT)

Address	Name	Setting range													
010AH	Wiring selection of output Y0 to Y1	1: Double wiring (default)													
<b>b15</b>	<b>b14</b>	<b>b13</b>	<b>b12</b>	<b>b11</b>	<b>b10</b>	<b>b9</b>	<b>b8</b>	<b>b7</b>	<b>b6</b>	<b>b5</b>	<b>b4</b>	<b>b3</b>	<b>b2</b>	<b>b1</b>	<b>b0</b>
Wiring selection of output Y1								Wiring selection of output Y0							

#### Point

When "1: Double wiring" is set, outputting on of a pair of outputs turns on the output signal.

## Input ON delay

Set the delay time of input OFF→ON.

### ■Setting specifications

Address	Name	Setting range
010BH+3×n (n: 0 to 11)	Input ON delay X0 to XB	0 to 1000 (ms) (default value: 5)

#### Point

- When "Wiring selection of input" is set to "1: Double wiring (NC/NC)" or "2: Double wiring (NC/NO)", set the same value as Xn for Xn+1, the partner of Xn.
- When "Input mode setting" is set to "1: Not used", this parameter will be ignored.

## Input OFF delay

Set the delay time of input ON→OFF.

### ■Setting specifications

Address	Name	Setting range
010CH+3×n (n: 0 to 11)	Input OFF delay X0 to XB	0 to 1000 (ms) (default value: 5)

#### Point

- When "Wiring selection of input" is set to "1: Double wiring (NC/NC)" or "2: Double wiring (NC/NO)", set the same value as Xn for Xn+1, the partner of Xn.
- When "Input mode setting" is set to "1: Not used", this parameter will be ignored.

## Input mode setting

Set the input setting of the safety remote I/O module in increments of one point. Also set whether or not to execute the input dark test.

### ■Setting specifications

Address	Name	Setting range
010DH+3×n (n: 0 to 11)	Input mode setting X0 to XB	1: Not used (default) 2: Input dark test execution 3: Input dark test non-execution

#### Point

- For unused input terminals, set "Input mode setting" to "1: Not used".
- When "Wiring selection of input" is set to "1: Double wiring (NC/NC)" or "2: Double wiring (NC/NO)", set the same value as Xn for Xn+1, the partner of Xn.

## Wiring selection of input

Set the input wiring method in increments of one point.

### ■Setting specifications

Address	Name	Setting range
012FH+2×n (n: 0 to 5)	Wiring selection of input X0/X1 to XA/XB	1: Double wiring (NC/NC) (default) 2: Double wiring (NC/NO) 3: Single wiring
<b>b15</b> <b>b14</b> <b>b13</b> <b>b12</b> <b>b11</b> <b>b10</b> <b>b9</b> <b>b8</b> <b>b7</b> <b>b6</b> <b>b5</b> <b>b4</b> <b>b3</b> <b>b2</b> <b>b1</b> <b>b0</b>	Wiring selection of input X1/X3/X5/X7/X9/XB	Wiring selection of input X0/X2/X4/X6/X8/XA

#### Point

Values for both X<sub>n</sub> (n: even number) and X<sub>n+1</sub> are set at the same time.

## Double input discrepancy detection time

Set the double input discrepancy detection time in increments of two points. Note that settings are done in units of words.

### ■Setting specifications

Address	Name	Setting range
0130H+2×n (n: 0 to 5)	Double input discrepancy detection time X0/X1 to XA/XB	10 to 30000 (ms) (default value: 10)

#### Point

When "Wiring selection of input" is set to "3: Single wiring" and "Input mode setting" is set to "1: Not used", this parameter will be ignored.

## Error history data

Up to 15 errors generated in the module are recorded.

The following table shows the storage data for Error history data 1 (address: 0A00H to 0A0FH).

### ■ Error history data 1 (address: 0A00H to 0A0FH)

Address	b15	b14	b13	b12	b11	b10	b9	b8	b7	b6	b5	b4	b3	b2	b1	b0
0A00H	Error code															
0A01H	Order of generation															
0A02H	First two digits of the year								Last two digits of the year							
0A03H	Month								Day							
0A04H	Hour								Minute							
0A05H	Second								00H (fixed)							
0A06H	Error code details 1															
0A07H	Error code details 2															
0A08H	Error code details 3															
0A09H	Error code details 4															
0A0AH	Error code details 5															
0A0BH	Error code details 6															
0A0CH	Error code details 7															
0A0DH	Error code details 8															
0A0EH	System area															
0A0FH																

#### Ex.

The following table lists data to be stored and storage examples of each item of error history data.

Item	Description	Storage example <sup>*1</sup>
Error code	The code of an error that has occurred is stored.	—
Order of generation	The order of error occurrence is stored. (The value of 0H to FFFFH is stored.)	0001H
First two digits of the year/Last two digits of the year <sup>*2</sup>	The items on the left are stored in BCD code.	2012H
Month/Day <sup>*2</sup>		0901H
Hour/Minute <sup>*2</sup>		1330H
Second <sup>*2</sup>		5000H
Error code details 1 to Error code details 8	The detailed information of some errors is stored. The data to be stored depend on the error.  Page 98 Error code details	—

\*1 Those values are for when the second error occurs at 13:30:50, September 1st, 2012.

\*2 The clock information of the error that occurred is based on the clock information acquired from the Safety CPU of the master station.  
When an error has occurred before the clock information is acquired from the Safety CPU, the error time is not recorded.

## Error history clear command

The error history stored in the module is cleared.

b15	b14	b13	b12	b11	b10	b9	b8	b7	b6	b5	b4	b3	b2	b1	b0
0 (fixed)															(1)

(1) 0: Not commanded, 1: Commanded

### Remote buffer memory address

Name	Address
Error history clear command	1000H

### Operation of error history clear

When Error history clear command (address: 1000H) is set to Commanded (1), an error history is cleared.

-----▶ Controlled by the safety remote I/O module  
 ———▶ Controlled by the program

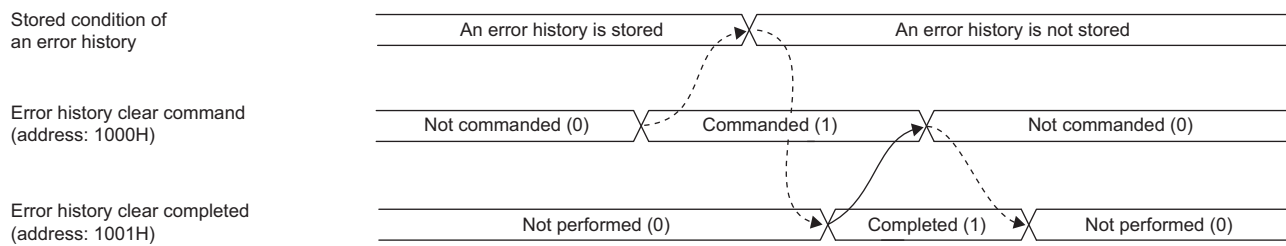

### Default value

The default value is Not commanded (0).

## Error history clear completed

This remote buffer memory area shows whether the error history stored in the module is cleared or not.

b15	b14	b13	b12	b11	b10	b9	b8	b7	b6	b5	b4	b3	b2	b1	b0
0 (fixed)															(1)

(1) 0: Not performed, 1: Completed

### Remote buffer memory address

Name	Address
Error history clear completed	1001H

### Operation of error history clear

When the error history clear is completed, Error history clear completed (address: 1001H) is turned to Completed (1).

For the timing when the bit turns to Not performed (0) → Completed (1) → Not performed (0), refer to the following.

☞ Page 123 Error history clear command

### Default value

The default value is Not performed (0).

## Parameter area initialization command

Set the parameters stored in a remote buffer memory and nonvolatile memory to the default value.

b15	b14	b13	b12	b11	b10	b9	b8	b7	b6	b5	b4	b3	b2	b1	b0
0 (fixed)															(1)

(1) 0: Not commanded, 1: Commanded

### Remote buffer memory address

Name	Address
Parameter area initialization command	1002H

### Operation of the parameter area initialization

When Parameter area initialization command (address: 1002H) is set to Commanded (1), the parameters stored in a nonvolatile memory are set to the default value.

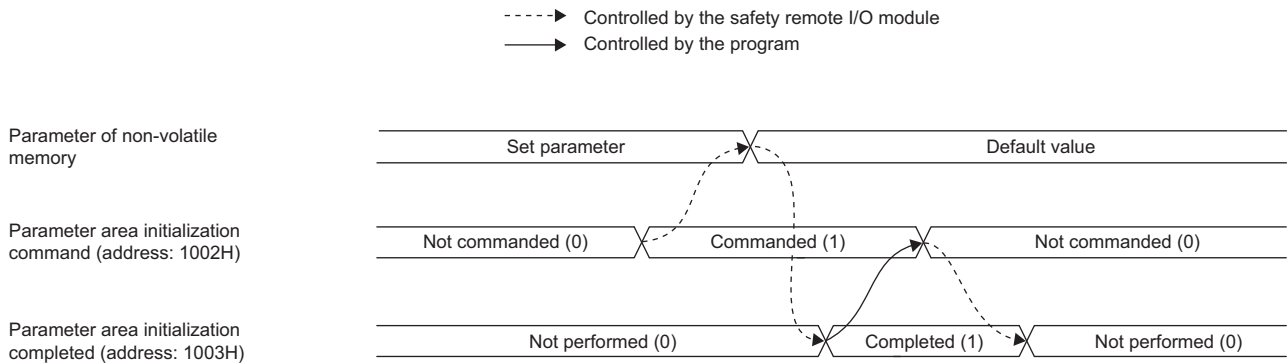

### Default value

The default value is Not commanded (0).

#### Point

After the parameters in a nonvolatile memory are set to the default value, the safety remote I/O module operates with the parameters of the default value.

## Parameter area initialization completed

This remote buffer memory area shows whether initialization of the parameters stored in a nonvolatile memory is completed or not.

b15	b14	b13	b12	b11	b10	b9	b8	b7	b6	b5	b4	b3	b2	b1	b0
0 (fixed)															(1)

(1) 0: Not performed, 1: Completed

### Remote buffer memory address

Name	Address
Parameter area initialization completed	1003H

### Operation of the parameter area initialization

When the initialization of the parameters stored in a nonvolatile memory is completed, Parameter area initialization completed (address: 1003H) is turned Completed (1).

For the timing when the bit turns to Not performed (0) → Completed (1) → Not performed (0), refer to the following.

☞ Page 124 Parameter area initialization command

### Default value

The default value is Not performed (0).

## Safety module enabled flag (address: 1005H)

Safety module enabled flag (address: 1005H) turns on when the set parameters can be used in the safety drive mode. When Safety module enabled flag (address: 1005H) is off, the mode cannot be switched to the safety drive mode. For details on the safety drive mode, refer to the following.

 Page 67 Module parameter setting procedure

b15	b14	b13	b12	b11	b10	b9	b8	b7	b6	b5	b4	b3	b2	b1	b0
0 (fixed)															(1)

(1) 0: Disable, 1: Enable

### Point

ON → OFF condition

- When setting or changing parameters in the engineering tool
- When the module detects a parameter error

OFF → ON condition

- When safety module validation is performed after the parameters have been set in the engineering tool

# Appendix 5 EMC, Low Voltage, and Machinery Directives

---

In each country, laws and regulations concerning electromagnetic compatibility (EMC) and electrical safety are enacted. For the products sold in the European countries, compliance with the EU's EMC Directive has been a legal obligation as EMC regulation since 1996, as well as the EU's Low Voltage Directive as electrical safety regulation since 1997.

Also, compliance with the EU's Machinery Directive has been a legal obligation since 1995.

Manufacturers who recognize their products are compliant with the EMC and Low Voltage Directives are required to attach a "CE marking" on their products in European countries.

In some other countries and regions, manufacturers are required to make their products compliant with applicable laws or regulations and attach a certification mark on the products as well (such as UK Conformity Assessed (UKCA) marking in the UK, and Korea Certification (KC) marking in South Korea).

Each country works to make their regulatory requirements consistent across countries based on international standards.

When the requirements are consistent, measures to comply with the EMC and electrical safety regulations become common across countries.

The UK and South Korea have enacted EMC regulations whose requirements are consistent with those of the EMC Directive. The UK has also enacted electrical safety regulations whose requirements are consistent with those of the Low Voltage Directive. In this section, the requirements of the EMC and Low Voltage Directives are described as examples of those of the EMC and electrical safety regulations.

## Measures to comply with the EMC Directive

---

The EMC Directive specifies that "products placed on the market must be so constructed that they do not cause excessive electromagnetic interference (emissions) and are not unduly affected by electromagnetic interference (immunity)".

This section summarizes the precautions on compliance with the EMC Directive of the machinery constructed with the module.

These precautions are based on the requirements and the standards of the regulation, however, it does not guarantee that the entire machinery constructed according to the descriptions will comply with abovementioned directives.

The method and judgment for complying with the EMC Directive must be determined by the person who constructs the entire machinery.



## EMC Directive related standards

### ■ Emission requirements

Standard	Test item	Test details	Value specified in standard
EN61131-2: 2007	CISPR16-2-3 Radiated emission	Radio waves from the product are measured.	<ul style="list-style-type: none"> <li>• 30 to 230MHz QP: 40dB<math>\mu</math>V/m (measured at 10m distance)<sup>*1</sup></li> <li>• 230 to 1000MHz QP: 47dB<math>\mu</math>V/m (measured at 10m distance)</li> </ul>
	CISPR16-2-1, CISPR16-1-2 Conducted emission	Noise from the product to the power line is measured.	<ul style="list-style-type: none"> <li>• 0.15 to 0.5MHz QP: 79dB, Mean: 66dB<sup>*1</sup></li> <li>• 0.5 to 30MHz QP: 73dB, Mean: 60dB</li> </ul>

\*1 QP: Quasi-peak value, Mean: Average value

### ■ Immunity requirements

Standard	Test item	Test details	Value specified in standard
EN61131-2: 2007	EN61000-4-2 Electrostatic discharge immunity	Immunity test in which electrostatic is applied to the cabinet of the equipment.	<ul style="list-style-type: none"> <li>• 8kV: Air discharge</li> <li>• 4kV: Contact discharge</li> </ul>
	EN61000-4-3 Radiated, radio-frequency, electromagnetic field immunity	Immunity test in which electric fields are irradiated to the product.	<ul style="list-style-type: none"> <li>• 80% AM modulation @1kHz</li> <li>• 80 to 1000MHz: 10V/m</li> <li>• 1.4 to 2.0GHz: 3V/m</li> <li>• 2.0 to 2.7GHz: 1V/m</li> </ul>
	EN61000-4-4 Electrical fast transient/ burst immunity	Immunity test in which burst noise is applied to the power line and signal line.	<ul style="list-style-type: none"> <li>• AC/DC main power, I/O power, AC I/O (unshielded) lines: 2kV</li> <li>• DC I/O, analog, communication lines: 1kV</li> </ul>
	EN61000-4-5 Surge immunity	Immunity test in which lightning surge is applied to the power line and signal line.	<ul style="list-style-type: none"> <li>• AC power, AC I/O power, AC I/O (unshielded) lines: 2kV CM, 1kV DM</li> <li>• DC power, DC I/O power lines: 0.5kV CM, 0.5kV DM</li> <li>• DC I/O, AC I/O (shielded), analog<sup>*1</sup>, communication lines: 1kV CM</li> </ul>
	EN61000-4-6 Immunity to conducted disturbances, induced by radio-frequency fields	Immunity test in which high frequency noise is applied to the power line and signal line	<ul style="list-style-type: none"> <li>• 0.15 to 80MHz,</li> <li>• 80% AM modulation @1kHz, 10Vrms</li> </ul>
	EN61000-4-8 Power-frequency magnetic field immunity	Immunity test in which the product is installed in inductive magnetic field	50/60Hz, 30A/m
	EN61000-4-11 Voltage dips and interruption immunity	Immunity test in which power supply voltage is momentarily interrupted	<ul style="list-style-type: none"> <li>• Apply at 0%, 0.5 cycles and zero-cross point</li> <li>• 0%, 250/300 cycles (50/60Hz)</li> <li>• 40%, 10/12 cycles (50/60Hz)</li> <li>• 70%, 25/30 cycles (50/60Hz)</li> </ul>

\*1 The accuracy of an analog-digital converter module may temporarily vary within  $\pm 10\%$ .

## External power supply

- Use a CE-marked product for an external power supply and always ground the FG metal fitting.
- Use a power cable of 10m or shorter when connecting it to the module power supply terminal.
- Use a power cable of 30m or shorter when connecting it to the load power supply.

## Others

### ■ Ferrite core

A ferrite core has the effect of reducing radiated noise in the 30MHz to 100MHz band.

It is recommended to attach ferrite cores if shielded cables coming out of the control panel do not provide sufficient shielding effects.

Note that the ferrite cores must be attached at the position closest to the cable hole inside the control panel. If attached at an improper position, the ferrite core will not produce any effect.

For the FG metal fitting that is connected to the load power supply of a safety remote I/O module and CC-Link IE Field Network cables, attach a ferrite core 4cm away from the module.

**Ex.**

Attaching a ferrite core

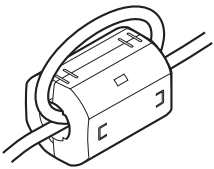

### ■ Noise filter (power supply line filter)

A noise filter is a component which has an effect on conducted noise. Attaching the filter can suppress more noise. (The noise filter has the effect of reducing conducted noise of 10MHz or less.)

Connect a noise filter to the load power supply of a safety remote I/O module. Use a noise filter with the damping characteristics equivalent to those of MA1206 (manufactured by TDK-Lambda Corporation). Note that a noise filter is not required if the module is used in Zone A defined in EN61131-2.

The precautions for attaching a noise filter are described below.

- Do not bundle the cables on the input side and output side of the noise filter. If bundled, the output side noise will be induced into the input side cables from which the noise was filtered.

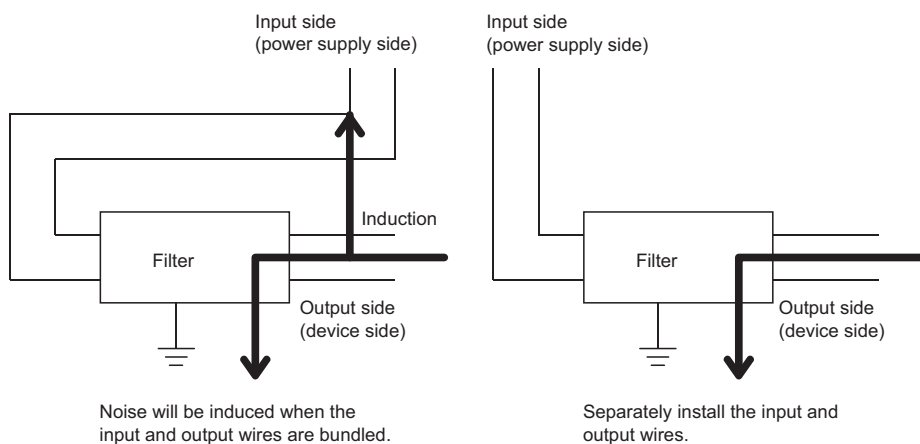

- Ground the noise filter grounding terminal to the control panel with the shortest cable possible (approx. 10cm).

## Requirements to compliance with the Low Voltage Directive

---

The module operates at the rated voltage of 24VDC.

The Low Voltage Directive does not apply to the modules that operate at the rated voltage of less than 50VAC and 75VDC.

## Measures to comply with the Machinery Directive

---

The Machinery Directive (2006/42/EC) requires that machinery satisfy the three pillars of safety: mechanical safety, electrical safety, and worker safety.

This product complies with the Machinery Directive (2006/42/EC). Before using this product, please read this manual, the relevant manuals, the manuals for standard programmable controller, and the safety standards carefully and pay full attention to safety to handle the product correctly.

The descriptions are based on the requirements of the Machinery Directive and the harmonized standards. However, they do not guarantee that the entire machinery constructed according to the descriptions complies with the Machinery Directive. The manufacturer of the machinery must determine the testing method for compliance and declare conformity to the Machinery Directive.

# Appendix 6 How to Check Serial Number and Function Version

The serial number and function version of the safety remote I/O module can be checked on the rating plate.

## Checking on the rating plate

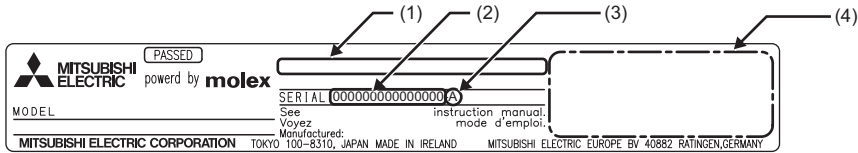

- (1) MAC address
- (2) Serial number
- (3) Function version
- (4) Relevant regulation standards

# Appendix 7 External Dimensions

The following figure shows the external dimensions of the safety remote I/O module.

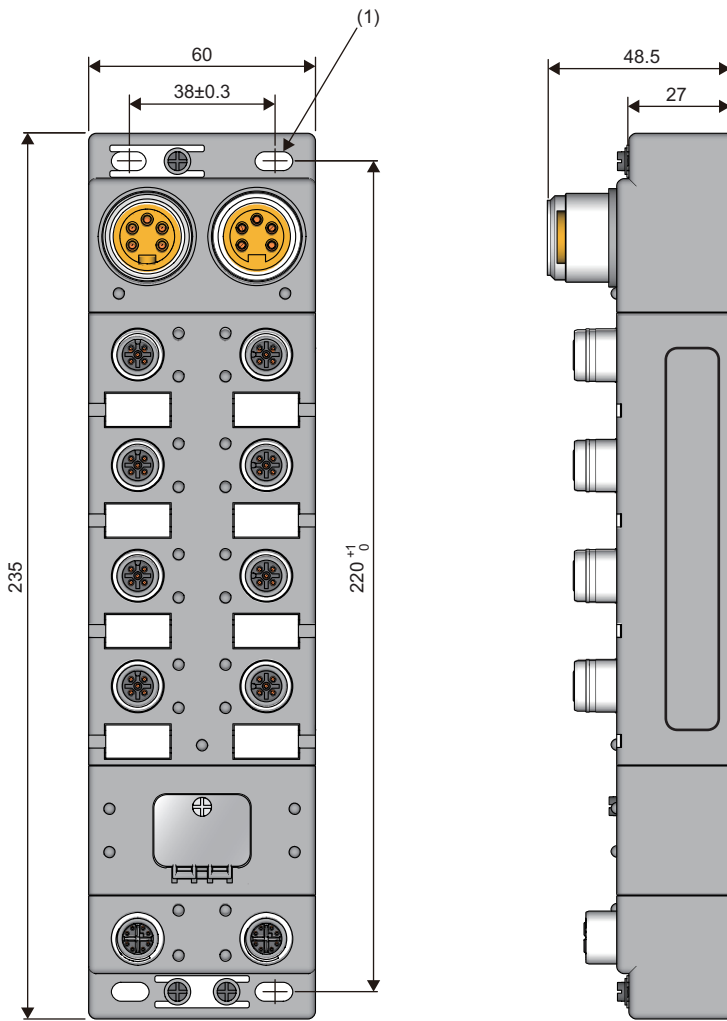

(Unit: mm)

(1) 4-5 × 10 slotted hole (M4 mounting screw)

A

# MEMO

---

# INDEX

## A

Applicable systems . . . . .	33
Attaching waterproof caps . . . . .	43

## C

Checking error codes and warning codes . . . . .	85
Checking module status . . . . .	83
Checking network status . . . . .	86
Checking the LEDs . . . . .	79
Checking with "Command Execution of Slave Station" . . . . .	83

## D

D LINK LED . . . . .	18
Daily inspection . . . . .	77
Double input discrepancy detection function . . . . .	53
Double input discrepancy detection time . . . . .	121

## E

ERR. LED . . . . .	18
Error code (RX10 to RX1F) . . . . .	110
Error code list . . . . .	95
Error codes related to CC-Link IE Field Network . . . . .	100
Error codes related to safety communication . . . . .	102
Error codes related to the safety remote I/O module . . . . .	95
Error history area (address: 0A00H to 0FFFH) . . . . .	116
Error history clear command . . . . .	123
Error history clear completed . . . . .	123
Error history data . . . . .	122
Error status flag (RXA) . . . . .	110
External dimensions . . . . .	131
External input monitor (RX30 to RX3F) . . . . .	111
External input signal monitor function . . . . .	48

## F

Fixing the safety remote I/O module . . . . .	39
Function list . . . . .	28

## H

How to check serial number and function version . . . . .	130
--	-----

## I

I/O LED . . . . .	17
Input dark test function . . . . .	55
Input diagnostic function . . . . .	53
Input function . . . . .	45
Input mode setting . . . . .	120
Input OFF delay . . . . .	120
Input ON delay . . . . .	120
Input ON delay, input OFF delay functions . . . . .	49
Input wiring selection function . . . . .	45
Installation direction . . . . .	38

Installation environment . . . . .	37
Installation environment and installation position . . . . .	37
Installation position . . . . .	38

## L

L ER LED . . . . .	18
L PW LED . . . . .	17
LINK LED . . . . .	18

## M

Maintenance and inspection . . . . .	77
Major error . . . . .	95
Measures to comply with the EMC Directive . . . . .	126
Measures to comply with the EMC Directive (EMC Directive related standards) . . . . .	127
Measures to comply with the EMC Directive (External power supply) . . . . .	128
Measures to comply with the EMC Directive (Others) . . . . .	128
Measures to comply with the Machinery Directive . . . . .	129
Minor error . . . . .	95
MODE LED . . . . .	17
Moderate error . . . . .	95
Module control data area (address: 1000H to 14FFH) . . . . .	117
Module parameter list . . . . .	72
Module parameter setting . . . . .	67
Module parameter setting of the master station . . . . .	64
Module status area (RX0 to RXF) . . . . .	109
Monitoring area (address: 0500H to 09FFH) . . . . .	115

## O

Operation mode and state transition . . . . .	30
Output dark test function . . . . .	57
Output dark test pulse time . . . . .	119
Output diagnostic function . . . . .	57
Output function . . . . .	50
Output mode setting . . . . .	119
Output read-back function . . . . .	59
Output wiring selection function . . . . .	50

## P

Parameter area initialization command . . . . .	124
Parameter area initialization completed . . . . .	124
Parameter settings . . . . .	62
Performance specifications . . . . .	20
Periodic inspection . . . . .	78
Power supply monitor (RX40 to RX45) . . . . .	111
Precautions for wiring the safety remote I/O module to safety devices . . . . .	44
Procedures before operation . . . . .	31
Product lineup . . . . .	13
PW LED . . . . .	17

## R

Remote buffer memory . . . . .	113
--------------------------------	-----

Remote I/O signals . . . . .	108
Remote READY (RXB) . . . . .	110
Remote register . . . . .	112
Replacing the module . . . . .	31
Requirements to compliance with the Low Voltage Directive . . . . .	129
RUN LED . . . . .	17

## S

---

Safety input signals . . . . .	107
Safety input status . . . . .	107
SAFETY LED . . . . .	17
Safety module enabled flag (address: 1005H) . . . . .	125
Safety output signal. . . . .	107
Safety output status . . . . .	107
Safety remote I/O module . . . . .	13
Safety remote I/O module safety response time . . . . .	27
Safety remote I/O signals. . . . .	104
Safety standards. . . . .	34
Setting the station number . . . . .	35
Setting the station number with the station number setting switch . . . . .	35
System configuration. . . . .	33

## T

---

Tightening torque . . . . .	36
Transmission interval monitoring time . . . . .	118
Troubleshooting . . . . .	79
Troubleshooting by symptom . . . . .	89
Troubleshooting for input circuit . . . . .	91
Troubleshooting for output circuit . . . . .	93

## U

---

Unit test . . . . .	88
User authentication function. . . . .	60

## W

---

Warning code (RX20 to RX2F) . . . . .	110
Warning status flag (RX7) . . . . .	109
Wiring . . . . .	40
Wiring of Ethernet cable. . . . .	41
Wiring selection of input. . . . .	121
Wiring selection of output. . . . .	119
Wiring the power supply. . . . .	40



# REVISIONS

\*The manual number is given on the bottom left of the back cover.

Revision date	*Manual number	Description
March 2019	SH(NA)-082076ENG-A	First edition
August 2019	SH(NA)-082076ENG-B	■Added or modified parts SAFETY PRECAUTIONS, Section 6.4, Appendix 2
March 2021	SH(NA)-082076ENG-C	■Added or modified parts SAFETY PRECAUTIONS, CONDITIONS OF USE FOR THE PRODUCT
November 2022	SH(NA)-082076ENG-D	■Added or modified part Appendix 5

Japanese manual number: SH-082075-D

This manual confers no industrial property rights or any rights of any other kind, nor does it confer any patent licenses. Mitsubishi Electric Corporation cannot be held responsible for any problems involving industrial property rights which may occur as a result of using the contents noted in this manual.

© 2019 MITSUBISHI ELECTRIC CORPORATION

# WARRANTY

---

Please confirm the following product warranty details before using this product.

## **1. Limited Warranty and Product Support.**

- a. Mitsubishi Electric Company ("MELCO") warrants that for a period of eighteen (18) months after date of delivery from the point of manufacture or one year from date of Customer's purchase, whichever is less, Mitsubishi MELSEC Safety programmable logic controllers (the "Products") will be free from defects in material and workmanship.
- b. At MELCO's option, for those Products MELCO determines are not as warranted, MELCO shall either replace them or issue a credit or return the purchase price paid for them.
- c. For this warranty to apply:
  - (1) Customer shall give MELCO (i) notice of a warranty claim to MELCO and the authorized dealer or distributor from whom the Products were purchased, (ii) the notice shall describe in reasonable details the warranty problem, (iii) the notice shall be provided promptly and in no event later than thirty (30) days after the Customer knows or has reason to believe that Products are not as warranted, and (iv) in any event, the notice must be given within the warranty period;
  - (2) Customer shall cooperate with MELCO and MELCO's representatives in MELCO's investigation of the warranty claim, including preserving evidence of the claim and its causes, meaningfully responding to MELCO's questions and investigation of the problem, grant MELCO access to witnesses, personnel, documents, physical evidence and records concerning the warranty problem, and allow MELCO to examine and test the Products in question offsite or at the premises where they are installed or used; and
  - (3) If MELCO requests, Customer shall remove Products it claims are defective and ship them to MELCO or MELCO's authorized representative for examination and, if found defective, for replacement. The costs of removal, shipment to and from MELCO's designated examination point, and reinstallation of replaced Products shall be at Customer's expense.
  - (4) If Customer requests and MELCO agrees to effect Product replacements onsite at any domestic or overseas location, the Customer will pay for the costs of sending personnel and shipping Products. MELCO is not responsible for any re-commissioning, maintenance, or testing on-site that involves replacing of the Products.

## **2. Limits of Warranties.**

- a. MELCO does not warrant or guarantee the design, specify, manufacture, construction or installation of the materials, construction criteria, functionality, use, properties or other characteristics of the equipment, systems, or production lines into which the Products may be incorporated, including any safety, fail-safe and shut down systems using the Products.
- b. MELCO is not responsible for determining the suitability of the Products for their intended purpose and use, including determining if the Products provide appropriate safety margins and redundancies for the applications, equipment or systems into which they are incorporated.
- c. Customer acknowledges that qualified and experienced personnel are required to determine the suitability, application, design, construction and proper installation and integration of the Products. MELCO does not supply such personnel.
- d. MELCO is not responsible for designing and conducting tests to determine that the Product functions appropriately and meets application standards and requirements as installed or incorporated into the end-user's equipment, production lines or systems.
- e. MELCO does not warrant any Product:
  - (1) altered by Customer;
  - (2) subjected to negligence, carelessness, accident, misuse, or damage;
  - (3) improperly stored, handled, installed or maintained;
  - (4) integrated or used in connection with improperly designed, incompatible or defective hardware or software;
  - (5) that fails because consumable parts such as batteries, backlights, or fuses were not tested, serviced or replaced;
  - (6) operated or used with equipment, production lines or systems that do not meet applicable and commensurate legal, safety and industry-accepted standards;
  - (7) operated or used in abnormal applications;
  - (8) installed, operated or used in contravention of instructions, precautions or warnings contained in MELCO's user, instruction and/or safety manuals, technical bulletins and guidelines for the Products;
  - (9) used with obsolete technologies or technologies not fully tested and widely accepted and in use at the time of the Product's manufacture;
  - (10) subjected to excessive heat or moisture, abnormal voltages, shock, excessive vibration, physical damage or other improper environment; or
  - (11) damaged or malfunctioning due to Acts of God, fires, acts of vandals, criminals or terrorists, communication or power failures, or any other cause or failure that results from circumstances beyond MELCO's control.
- f. All Product information and specifications contained on MELCO's website and in catalogs, manuals, or technical information materials provided by MELCO are subject to change without prior notice.
- g. The Product information and statements contained on MELCO's website and in catalogs, manuals, technical bulletins or other materials provided by MELCO are provided as a guide for Customer's use. They do not constitute warranties and are not incorporated in the contract of sale for the Products.
- h. These terms and conditions constitute the entire agreement between Customer and MELCO with respect to warranties, remedies and damages and supersede any other understandings, whether written or oral, between the parties. Customer expressly acknowledges that any representations or statements made by MELCO or others concerning the Products outside these terms are not part of the basis of the bargain between the parties and are not factored into the pricing of the Products.
- i. THE WARRANTIES AND REMEDIES SET FORTH IN THESE TERMS ARE THE EXCLUSIVE AND ONLY WARRANTIES AND REMEDIES THAT APPLY TO THE PRODUCTS.
- j. MELCO DISCLAIMS THE IMPLIED WARRANTIES OF MERCHANTABILITY AND FITNESS FOR A PARTICULAR PURPOSE.

### **3. Limits on Damages.**

- a. MELCO'S MAXIMUM CUMULATIVE LIABILITY BASED ON ANY CLAIMS FOR BREACH OF WARRANTY OR CONTRACT, NEGLIGENCE, STRICT TORT LIABILITY OR OTHER THEORIES OF RECOVERY REGARDING THE SALE, REPLACEMENT, DELIVERY, PERFORMANCE, CONDITION, SUITABILITY, COMPLIANCE, OR OTHER ASPECTS OF THE PRODUCTS OR THEIR SALE, INSTALLATION OR USE SHALL BE LIMITED TO THE PRICE PAID FOR PRODUCTS NOT AS WARRANTED.
- b. Although MELCO has obtained the certification for Product's compliance to the international safety standards IEC61508 and EN954-1/ISO13849-1 from TUV Rheinland, this fact does not guarantee that Product will be free from any malfunction or failure. The user of this Product shall comply with any and all applicable safety standard, regulation or law and take appropriate safety measures for the system in which the Product is installed or used and shall take the second or third safety measures other than the Product. MELCO is not liable for damages that could have been prevented by compliance with any applicable safety standard, regulation or law.
- c. MELCO prohibits the use of Products with or in any application involving power plants, trains, railway systems, airplanes, airline operations, other transportation systems, amusement equipments, hospitals, medical care, dialysis and life support facilities or equipment, incineration and fuel devices, handling of nuclear or hazardous materials or chemicals, mining and drilling, and other applications where the level of risk to human life, health or property are elevated.
- d. MELCO SHALL NOT BE LIABLE FOR SPECIAL, INCIDENTAL, CONSEQUENTIAL, INDIRECT OR PUNITIVE DAMAGES, FOR LOSS OF PROFITS, SALES, OR REVENUE, FOR INCREASED LABOR OR OVERHEAD COSTS, FOR DOWNTIME OR LOSS OF PRODUCTION, FOR COST OVERRUNS, OR FOR ENVIRONMENTAL OR POLLUTION DAMAGES OR CLEAN-UP COSTS, WHETHER THE LOSS IS BASED ON CLAIMS FOR BREACH OF CONTRACT OR WARRANTY, VIOLATION OF STATUTE, NEGLIGENCE OR OTHER TORT, STRICT LIABILITY OR OTHERWISE.
- e. In the event that any damages which are asserted against MELCO arising out of or relating to the Products or defects in them, consist of personal injury, wrongful death and/or physical property damages as well as damages of a pecuniary nature, the disclaimers and limitations contained in these terms shall apply to all three types of damages to the fullest extent permitted by law. If, however, the personal injury, wrongful death and/or physical property damages cannot be disclaimed or limited by law or public policy to the extent provided by these terms, then in any such event the disclaimer of and limitations on pecuniary or economic consequential and incidental damages shall nevertheless be enforceable to the fullest extent allowed by law.
- f. In no event shall any cause of action arising out of breach of warranty or otherwise concerning the Products be brought by Customer more than one year after the cause of action accrues.
- g. Each of the limitations on remedies and damages set forth in these terms is separate and independently enforceable, notwithstanding the unenforceability or failure of essential purpose of any warranty, undertaking, damage limitation, other provision of these terms or other terms comprising the contract of sale between Customer and MELCO.

### **4. Repair and Analysis**

Please note that repairs and failure analysis are refused due to the structure of this product.

### **5. Discontinuation of Production**

- a. Discontinuation of production shall be notified with Mitsubishi Technical Bulletins, etc.
- b. Product supply (including repair parts) is not available after production is discontinued.

### **6. Overseas Service**

Overseas, please contact Mitsubishi's local overseas FA Center.

### **7. Delivery/Force Majeure.**

- a. Any delivery date for the Products acknowledged by MELCO is an estimated and not a promised date. MELCO will make all reasonable efforts to meet the delivery schedule set forth in Customer's order or the purchase contract but shall not be liable for failure to do so.
- b. Products stored at the request of Customer or because Customer refuses or delays shipment shall be at the risk and expense of Customer.
- c. MELCO shall not be liable for any damage to or loss of the Products or any delay in or failure to deliver, service, or replace the Products arising from shortage of raw materials, failure of suppliers to make timely delivery, labor difficulties of any kind, earthquake, fire, windstorm, flood, theft, criminal or terrorist acts, war, embargoes, governmental acts or rulings, loss or damage or delays in carriage, acts of God, vandals or any other circumstances reasonably beyond MELCO's control.

### **8. Choice of Law/Jurisdiction.**

These terms and any agreement or contract between Customer and MELCO shall be governed by the laws of the State of New York without regard to conflicts of laws. To the extent any action or dispute is not arbitrated, the parties consent to the exclusive jurisdiction and venue of the federal and state courts located in the Southern District of the State of New York. Any judgment there obtained may be enforced in any court of competent jurisdiction.

### **9. Arbitration.**

Any controversy or claim arising out of, or relating to or in connection with the Products, their sale or use or these terms, shall be settled by arbitration conducted in accordance with the Center for Public Resources (CPR) Rules for Non-Administered Arbitration of International Disputes, by a sole arbitrator chosen from the CPR's panels of distinguished neutrals. Judgment upon the award rendered by the Arbitrator shall be final and binding and may be entered by any court having jurisdiction thereof. The place of the arbitration shall be New York City, New York. The language of the arbitration shall be English. The neutral organization designated to perform the functions specified in Rule 6 and Rules 7.7(b), 7.8 and 7.9 shall be the CPR.

# TRADEMARKS

---

The company names, system names and product names mentioned in this manual are either registered trademarks or trademarks of their respective companies.

In some cases, trademark symbols such as <sup>™</sup> or <sup>®</sup> are not specified in this manual.



**molex** Molex, LLC [www.molex.com](http://www.molex.com)

SH(NA)-082076ENG-D(2211)MEE

MODEL: CCIEF-WDSFIO-U-E

MODEL CODE: 13JX0B

## **mitsubishi electric corporation**

HEAD OFFICE : TOKYO BUILDING, 2-7-3 MARUNOUCHI, CHIYODA-KU, TOKYO 100-8310, JAPAN  
NAGOYA WORKS : 1-14, YADA-MINAMI 5-CHOME, HIGASHI-KU, NAGOYA, JAPAN

When exported from Japan, this manual does not require application to the  
Ministry of Economy, Trade and Industry for service transaction permission.

Specifications subject to change without notice.