

MELSOFT

Visual Inspection Software

MELSOFT VIXIO User's Manual

-SW1DND-AIVILE-M
-SW1DND-AIVIIN-M



SAFETY PRECAUTIONS

(Read these precautions before using this product.)

Before using this product, please read this manual and the relevant manuals carefully and pay full attention to safety to handle the product correctly. If the equipment is used in a manner not specified by the manufacturer, the protection provided by the equipment may be impaired.

The precautions given in this manual are concerned with this product only. For the safety precautions of the programmable controller system, refer to MELSEC iQ-R Module Configuration Manual.

In this manual, the safety precautions are classified into two levels: "⚠️ WARNING" and "⚠️ CAUTION".

 WARNING	Indicates that incorrect handling may cause hazardous conditions, resulting in death or severe injury.
 CAUTION	Indicates that incorrect handling may cause hazardous conditions, resulting in minor or moderate injury or property damage.

Under some circumstances, failure to observe the precautions given under "⚠️ CAUTION" may lead to serious consequences.

Observe the precautions of both levels because they are important for personal and system safety.

Make sure that the end users read this manual and then keep the manual in a safe place for future reference.

[Design Precautions]

WARNING

- To perform an operation, such as data change or operating status change, to running devices, such as a programmable controller, servo, robot, or server, from the learning machine or inspection machine, configure an interlock circuit outside of the devices so that the entire system always operates to the safety side. Additionally, read this manual carefully and ensure the safety before operations. Especially, in the above mentioned operations that are performed from external devices through network, any problems on devices may not be dealt with promptly due to an abnormal data communication.
 - Configure a safety circuit outside of the learning machine or inspection machine equipped with this product so that the entire system operates to the safely side even when a fault occurs in the learning machine or inspection machine.
Failure to do so may result in an accident due to an incorrect output or malfunction.
-

[Design Precautions]

CAUTION

- Do not perform the operation that forcibly turns the learning machine or inspection machine OFF. Otherwise, the data will be undefined and resetting and re-registering data will be required. Additionally, doing so may cause the malfunction of this product.
-

[Security Precautions]

WARNING

- To maintain the security (confidentiality, integrity, and availability) of access target devices and the system against unauthorized access, denial-of-service (DoS) attacks, computer viruses, and other cyberattacks from external devices via the network, take appropriate measures such as firewalls, virtual private networks (VPNs), and antivirus solutions.
-

[Learning Precautions]

CAUTION

- Using incorrect image data and labels may significantly lower the accuracy of an AI model. Additionally, due to the mechanism of an AI, the accuracy of inspection cannot be guaranteed even when using correct learning data. Therefore, for devices (such as safety control devices) that can cause serious consequences, do not use the output of this product as a control signal. In other systems, it is recommended to take multiple measures against any risks (such as false-positives and over-detection) by using and operating non-AI functions.
 - Learning results may not match between the generated AI models even if performing learning for multiple times using the same data sets under the same conditions.
 - The accuracy displayed in the evaluation screen during learning is just an index which is determined when performing inspection for learning images; therefore, it is not guaranteed to have the same accuracy during operation.
-

[Precautions when using this product in China]

CAUTION

- Some characters defined in GB 18030-2022 cannot be used.

[Precautions for installation]

- Use only alphanumeric characters for a customer name and company name at the installation of this product. In addition, use only the default folder as the installation folder.

If any operation other than that described above is performed, this product may not run properly. For example, characters are not displayed on this product.

[Precautions for a project file saving destination]

- Use only alphanumeric characters for the name of a folder and file in the destination to which project files of this product are imported or exported. The same is true for changing a saved file name.

If any other character is used, this product may not run properly. For example, saving processing is canceled.

CONDITIONS OF USE FOR THE PRODUCT

- (1) This software shall be used under the following conditions;
 - i) that any failure occurred in this software, if any, shall not lead to any serious accident.
 - ii) that the backup and/or fail-safe functions are systematically performed outside the devices in the cases of any failure occurred in this software.
- (2) Mitsubishi Electric assumes no responsibility and liability (including but not limited to, default liability, defect liability, quality assurance responsibility, tort liability, product liability) for the quality, performance, and safety of both this software and products using this software.
- (3) Mitsubishi Electric shall have no responsibility or liability for any problems involving this software and system trouble caused by DoS attacks, unauthorized access, computer viruses, and other cyberattacks.

INTRODUCTION

Thank you for purchasing the visual inspection software, MELSOFT VIXIO.

This manual describes the procedures before operation, operation methods, and troubleshooting of MELSOFT VIXIO.

Before using MELSOFT VIXIO, please read this manual and the relevant manuals carefully, and develop familiarity with the functions and performance of this product to handle correctly.

Note that the menu names and operating procedures may differ depending on an operating system in use and its version.

When reading this manual, replace the names and procedures with the applicable ones as necessary.

Please make sure that the end users read this manual.

Model names of supported products

The product model names described in this manual are omitted.

A symbol or number indicating a license form may be in the omitted part.

CONTENTS

SAFETY PRECAUTIONS	1
CONDITIONS OF USE FOR THE PRODUCT	3
INTRODUCTION	4
RELEVANT MANUALS	8
TERMS	8
CHAPTER 1 MELSOFT VIXIO	9
CHAPTER 2 SYSTEM CONFIGURATION	11
2.1 System Configuration	11
Components	11
Operating environment	14
Overall system configuration	16
Considerations for a system configuration	18
2.2 Licenses	19
CHAPTER 3 SPECIFICATIONS	20
3.1 Software Specifications	20
3.2 Image Data Specifications	20
CHAPTER 4 PROCEDURE BEFORE OPERATION	22
4.1 Starting Using this Product with the Development License	23
4.2 Starting Using this Product with the Run-time License	25
CHAPTER 5 BASIC OPERATIONS	26
5.1 Registration Procedure for a License	26
5.2 Startup Procedure for this Product	28
Changing operation status	28
5.3 Procedure for Opening the Operation Screen	29
Displaying a web browser	29
Signing up	31
Signing in	32
5.4 Screen Configuration	33
Startup tool	33
License Manager	35
Operation screen	38
CHAPTER 6 USER ACCOUNT	43
6.1 Creation Procedure for a User Account	44
Creating a new user account	44
Setting access authority for a user account	45
6.2 User Management Screen	47
CHAPTER 7 PROJECT	49
7.1 Creation Procedure for a Project	49
Creating a new project	49
Setting Members	50
7.2 Exporting and Importing Procedure for a Project	51

Export	52
Import	53
7.3 Project Management Screen	55

CHAPTER 8 DATA SET 58

8.1 Data Set	58
8.2 Creation Procedure for a Data Set	59
Creating a new data set.	59
Setting a data set.	60
8.3 Data Set Management Screen	65
8.4 Data Set Setting Screen	68
Enlarged image display.	70
Pixel marking settings	71

CHAPTER 9 AI MODEL 73

9.1 AI Model	73
AI engine	73
Preprocessing	74
AI model status	75
9.2 Creation Procedure for an AI Model	76
Creating an AI model.	76
Setting an AI model	77
Validating an AI model.	79
9.3 Deployment Procedure for an AI Model	80
9.4 AI Model Management Screen	83
9.5 AI Model Setting Screen	86
Data set selection screen	87
Preprocessing selection screen.	89
AI engine setting screen	93
9.6 AI Model Validation Screen.	98

CHAPTER 10 TASK 102

10.1 Task.	102
Task status.	103
Execution order of a processing block.	104
10.2 Creation Procedure for a Task	107
Creating a new task.	107
Setting a task.	109
10.3 Deployment Procedure for a Task	115
10.4 Task Management Screen.	118
Auto start setting	121
10.5 Task Flow Setting Screen	122
Changing a block name.	124

CHAPTER 11 PROCESSING BLOCK 125

11.1 Processing Block List.	125
11.2 Machine Integration Category	126
PLC data reading block.	126
PLC data writing block.	139
Imaging block	145

Image import block	152
11.3 AI Model Inspection Category	155
AI model execution blocks	155
11.4 Utility Category	159
Conditional branch block	159
Monitor input waiting block	162
CHAPTER 12 TASK OPERATION	163
12.1 Operation Procedure for a Task	163
Starting a task	163
Checking a task status	164
Checking an inspection result history	165
12.2 Improvement of AI Models	166
12.3 Task Monitor Screen	167
12.4 Inspection Result History Check Screen	171
CHAPTER 13 EVENT/ERROR HISTORY CHECK	173
CHAPTER 14 PERSONAL SETTINGS	176
CHAPTER 15 TROUBLESHOOTING BY SYMPTOM	178
APPENDIX	186
Appendix 1 Unusable Characters for this Product	186
Appendix 2 Folder Configuration	187
Inspection result history	187
Image data downloaded in the inspection result history check screen	188
Appendix 3 Software Licenses	189
INDEX	191
REVISIONS	193
INFORMATION AND SERVICES	194
TRADEMARKS	194
COPYRIGHTS	194

RELEVANT MANUALS

Manual name [manual number]	Description	Available form
MELSOFT VIXIO User's Manual [SH-082628ENG] (this manual)	System configuration, procedure before operation, operation methods, and troubleshooting of MELSOFT VIXIO	PDF

TERMS

Unless otherwise specified, this manual uses the following terms.

Term	Description
Data stream	A flow of data (input and output of a processing block) in a task flow. The output data of each processing block is transmitted along the data stream to the next connected processing block(s).
Deploy	A function that places AI models and tasks from the learning machine into the inspection machine or another learning machine via a network
Inspection	Processing to determine non-defective and defective products using an AI model.
Processing block	Execution processing in a task. There are several types of processing blocks such as the PLC data reading block and imaging block.
Task flow	A connection of processing blocks that represents a data flow and the execution order of the blocks

1 MELSOFT VIXIO

This product is software that performs visual inspection by linking with external devices such as cameras. The following functions that are required for a visual inspection system can be easily built without a program.

- Capturing images with cameras
- Generating and executing an AI model
- Linking to a programmable controller
- Monitoring

In addition, the results of visual inspection can be linked to various data, such as input images, and saved. Therefore, the inspection data of each process can be used for traceability.

MEMO

2 SYSTEM CONFIGURATION

This chapter shows the system configuration and licenses of this product.

2.1 System Configuration

2

This section shows the system configuration of this product.

Components

This product requires devices such as an operation terminal, learning machine, inspection machine, and cameras.

Device	Description
Learning machine (personal computer, industrial PC, or server)	An environment to generate an AI model by performing learning and execute a task. Use an installer of this product to build this environment.
Inspection machine (personal computer, industrial PC, or server)	An environment to deploy or import an AI model generated with the learning machine and execute a task. Use an installer of this product to build this environment.
Operation terminal (personal computer or tablet ^{*1})	An environment to access the operation screen of this product on the web browser and operate this product. (It is not required when accessing an operation screen on the learning machine or inspection machine.)
GigE Vision camera (GenICam standard compatible camera)	It is used for capturing images of a learning target and inspection target. Use an Ethernet cable (category 5e or higher) to connect a camera to a personal computer. When supplying power through an Ethernet cable, connect a camera to a personal computer via a PoE compatible switching hub or PoE compatible Ethernet board.
Programmable controller	It is used for controlling a capturing timing and linking work information (a lot number and work ID) with this product. In addition, it is used for getting feedback on inspection results from this product. Use an Ethernet cable to connect the device to a personal computer. For available CPU module types and access routes, refer to the following:  Page 12 Accessible CPU modules, Page 13 Accessible routes
PoE switching hub	It is used for connecting a camera to a personal computer and supplying power to the camera.
PoE compatible Ethernet board	It is used for connecting a camera to a personal computer directly and supplying power to the camera.
File server	A server for storing execution results of tasks. (It is not required when storing the results in an inspection machine.) Image files for learning can be saved and also can be read at each learning.

*1 A tablet can only be used for browsing the task monitor screen.

For details on external devices for which operation has been confirmed, refer to the following technical bulletin:

 Applicable Industrial Cameras for MELSOFT VIXIO (FA-A-0419)

Precautions

Do not use a USB-Ethernet conversion adapter in a connection route between a camera and a personal computer. Otherwise, the camera operation may become unstable due to a communication delay or noise in the captured images.

Accessible CPU modules

The following shows the list of accessible CPU modules.

For accessible devices, refer to the following:

 Page 133 Accessible devices

Series	Type	Model name	Remarks	
RCPU	RnCPU	R00	—	
		R01		
		R02		
		R04		
		R08		
		R16		
		R32		
		R120		
	RnPCPU	R08P	The redundant mode is not available.	
		R16P		
		R32P		
		R120P		
	RnENCPU	R04EN	—	
		R08EN		
		R16EN		
		R32EN		
		R120EN		
	Rsafety	RnSF CPU	R08SF	
			R16SF	
R32SF				
R120SF				
FX5CPU	FX5CPU	FX5U	Select "FX5U/FX5UC" to use these modules.	
		FX5UC		
QCPU	QnU(J)CPU QnUD(E)H CPU	Q00U	—	
		Q00UJ		
		Q01U		
		Q02U		
		Q03UD		
		Q04UDH		
		Q06UDH		
		Q10UDH		
		Q13UDH		
		Q20UDH		
		Q26UDH		
		Q03UDE		
		Q04UDEH		
		Q06UDEH		
		Q10UDEH		
		Q13UDEH		
		Q20UDEH		
		Q26UDEH		
		Q50UDEH		
		Q100UDEH		

Series	Type	Model name	Remarks
QCPU	QnUDPVCPU	Q04UDPV	—
		Q06UDPV	
		Q13UDPV	
		Q26UDPV	
	QnUDVCPU	Q03UDV	
		Q04UDV	
		Q06UDV	
		Q13UDV	
		Q26UDV	
LCPUCPU	LnCPU	L02S	Select "L02S/L02S-P" to use this module.
		L02S-P	
		L02	Select "L02/L02-P" to use these modules.
		L02-P	
		L06	Select "L06/L06-P" to use this module.
		L06-P	
		L26	Select "L26/L26-P" to use this module.
		L26-P	
		L26-BT	Select "L26-BT/L26-PBT" to use this module.
		L26-PBT	

Accessible routes

The following shows the accessible routes to a CPU module.

Accessible routes differ depending on the type of an access target CPU module.

■ When the personal computer side I/F is Ethernet Board

○: Accessible, △: Partially accessible, ×: Not accessible

Access target CPU module	Device I/F ^{*1}						
	RJ71EN71 (Direct)	RJ71EN71 (Specify IP Address)	QJ71E71 (Specify IP Address)	LJ71E71 (Specify IP Address)	Ethernet Port (Direct)	Ethernet Port (Specify IP Address)	RJ71GN11-T2 (Specify IP Address)
RCPUCPU	○	○	×	×	○	○	△ ^{*2}
Rsafety	○	○	×	×	○	○	○
FX5CPU	×	×	×	×	○	○	×
QCPU	×	×	○	×	△ ^{*3}	△ ^{*3}	×
LCPUCPU	×	×	×	○	△ ^{*4}	△ ^{*4}	×

*1 The meaning of 'Direct' and 'Specify IP Address' is as follows:

- Direct: When connecting a device directly
- Specify IP Address: When connecting a device by specifying the IP address

*2 Not accessible for the following models:

- R08P
- R16P
- R32P
- R120P

*3 Not accessible for the following models:

- Q01U
- Q02U
- Q03UD
- Q04UDH
- Q06UDH
- Q10UDH
- Q13UDH
- Q20UDH
- Q26UDH

*4 Not accessible for the following models:

- L02S
- L02S-P

Operating environment

The following shows the operating environment required for each device.

Learning machine and inspection machine

For the operating environment of the learning machine and inspection machine, refer to the following:

📖 MELSOFT VIXIO Installation Instructions

Operation terminal

The following table shows the operating environment of an operation terminal.

Item	Description	
Personal computer	—	Personal computer or tablet*1
	CPU	Recommended: Intel® Core-i5 9th generation (October 2018) or higher Required*2: Intel Core-i3 (2018) or higher
	Required memory	Recommended: 8 GB or more Required*2: 4 GB or more
Web browser	Microsoft Edge® (Version: 102 or later) Google Chrome® (Version: 102 or later)	
OS (64-bit version) (Japanese version, English version, Simplified Chinese version)	Windows® 11 Version 22H2 or later (Pro, Enterprise) Windows 10 Version 21H2 or later (Pro, Enterprise)	
Monitor	Resolution 1920 × 1080 dots or more	
Free storage space	Recommended: 64 GB or more Required*2: 32 GB or more	

*1 A tablet can only be used for browsing the task monitor screen.

*2 Available to monitor inspection results for one task when other tools on the personal computer are not running.

Precautions

- When the following functions are used, this product may not run properly.
 - Application start-up in Windows compatibility mode
 - Fast user switching
 - Touch function
 - Virtual environment such as Client Hyper-V and execution environment on the cloud
 - Virtual desktop
 - Tablet mode
 - Windows hibernate or standby
 - Unified Write Filter
 - Fast startup
 - Multiboot
 - Modes other than normal mode such as secret mode on the browser, InPrivate Browsing, and Internet Explorer mode
- In the following cases, the screen of this product may not work properly.
 - The size of the text and other items in the screen is other than 100% (96 DPI, 9 pt etc.).^{*3}
 - The resolution of the screen is changed in operation.
 - The multi-display is set.
 - A tablet (including a mouse operation) is used for a purpose other than browsing the task monitor screen.

*3 When setting 100%, contents in the screen are displayed properly with the display resolution of 1920 × 1080 px. If the size of the text and other items in the screen is other than 100% and the display resolution is other than 1920 × 1080 px, contents in the screen may not be displayed properly depending on the zoom level of a web browser. The following shows the recommended zoom level for each display resolution:

- Display resolution: 1024 × 768 px or more, zoom: 75%
 - Display resolution: 1280 × 800 px or more, zoom: 75%
 - Display resolution: 1280 × 1024 px or more, zoom: 75%
 - Display resolution: 1920 × 1080 px or more (recommended), zoom: 100%
- Use this product with the authority of a 'Standard user' or 'Administrator'.
 - When remote desktop is used, the following cases may occur.
 - Screen update is slow during monitoring or operation due to the network environment (such as speed or load).
 - Some texts or a part of a window get cut due to the screen settings of remote desktop.

Overall system configuration

The following shows the overall system configuration.

There are the following phases when using this product:

- Learning phase: A phase to generate an AI model
- Inspection phase: A phase to perform inspection using the generated AI model

Learning phase

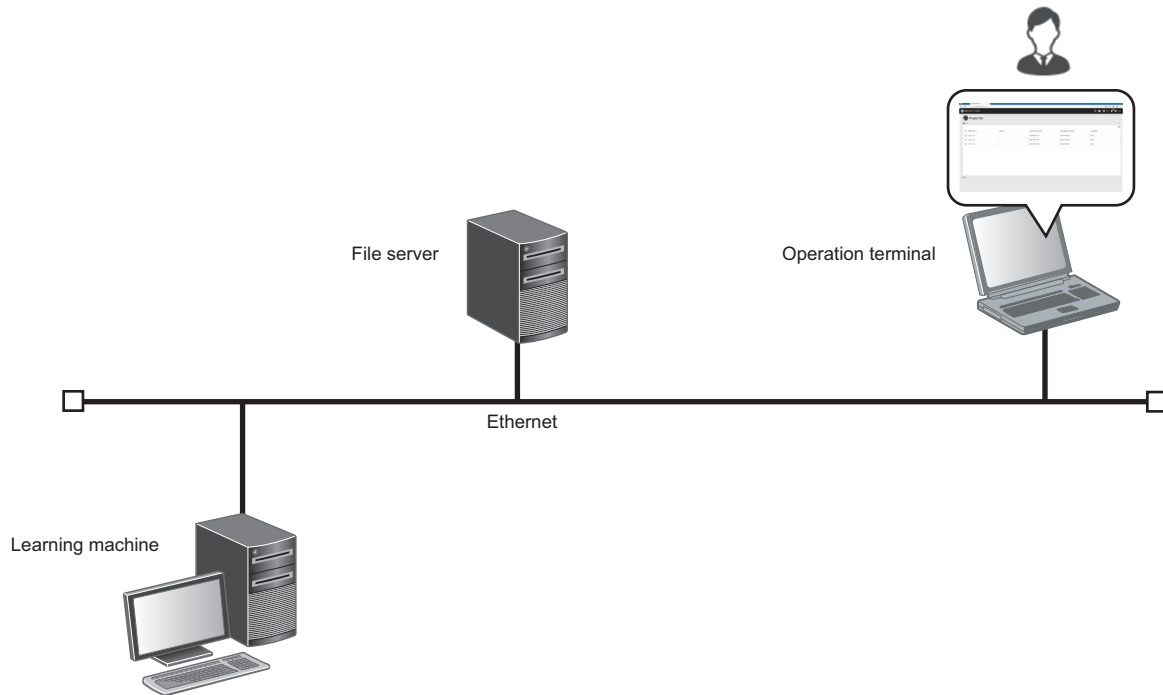

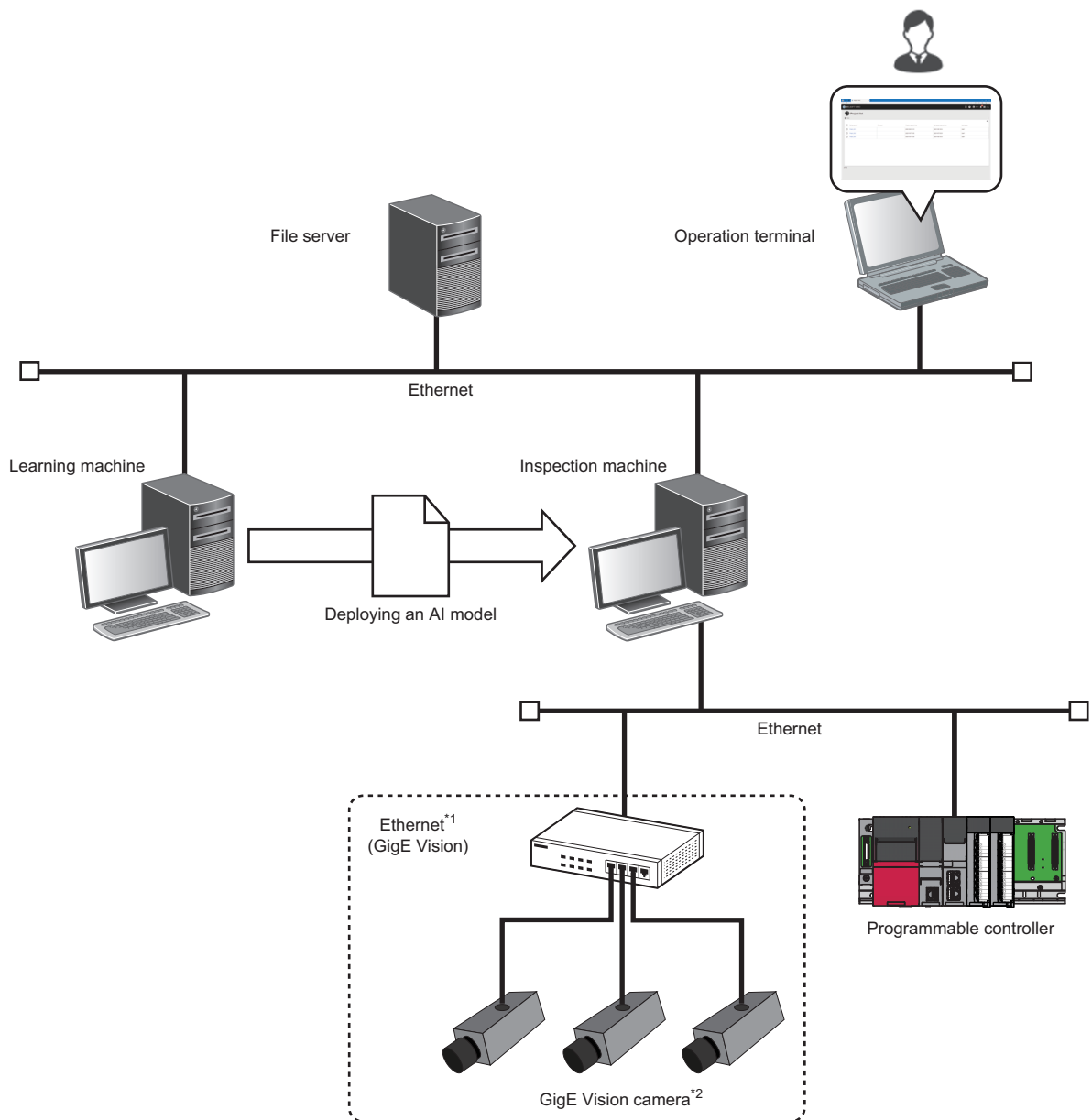

*1 When supplying power through an Ethernet cable, connect the camera to the computer via a PoE compatible switching hub or PoE compatible Ethernet board.

*2 Do not use a USB-Ethernet conversion adapter in a connection route between a camera and a personal computer. Otherwise, the camera operation may become unstable due to a communication delay or noise in the captured images.

Considerations for a system configuration

Operations are not guaranteed in the system configuration in which a VPN client is started in the learning machine and inspection machine.

This product may not be started properly depending on the setting environment of a VPN client.

Recommendations

The following shows recommendations for capturing stable images.

- Use a PoE compatible Ethernet board and connect a camera to the LAN port on a 1:1 basis.
Connecting multiple cameras to the LAN port via a PoE switching hub may cause noise in the captured images, depending on the line load.
- Enable the jumbo packet (jumbo frame) setting for the Ethernet board of a personal computer and set the maximum packet size allowed for the Ethernet board. Disabling the jumbo packet setting may cause noise in the captured images.
- Use a screw-lock cable to connect to a GigE Vision camera to prevent the cable from being unplugged.

2.2 Licenses

This section shows the license types of this product.

License	Description	Validity period
Development license	A node-locked license to perform AI model learning and to perform inspection with a task, which uses a generated AI model. The license can be obtained by applying for it after purchasing this product.	One year after the license is issued (For renewing the license: The remaining period of the current license + one year)
Run-time license	A node-locked license to deploy or import AI models generated with the development license and then to set tasks and perform inspection with the imported AI models. The license can be obtained by applying for it after purchasing this product.	Indefinite period
Temporary license	A license to be provided when purchasing this product. The license can be used temporarily instead of the development license.	30 days after registration (Available to use only once per personal computer)

Registration and management method

License Manager is used to register and manage licenses.

For details on License Manager, refer to the following:

 Page 35 License Manager

Operations available for each license

■ Development license and temporary license

All operations of each function are available.

■ Run-time license

Available operations for each function are as follows:

The menus of unavailable operations are not displayed. In addition, the following menus are not displayed when using the run-time license.

- AI model validation
- Properties (AI model management screen)

○: Available, ×: Not available, —: Not applicable

Function	Operation of each function								
	List display	Browsing a setting screen* ¹	New	Duplicate	Delete	Execute	Deploy	Import	Export
Project	○	○	○	○	○	—	—	○	○
Data set	×	×	×	×	×	—	—	×	×
AI model	○	×	×	×	○	—	×	○	×
Task	○	○	○	○	○	○	×	○	○

*1 The following shows the corresponding screen for each function.
 Project: Task management screen
 Data set: Data set setting screen
 AI model: AI model setting screen and AI model validation screen
 Task: Task setting screen

Precautions

When changing to the run-time license on a computer where the development license was used, settings created with the development license cannot be used.

3 SPECIFICATIONS

This chapter shows the performance specifications of this product.

3.1 Software Specifications

This section shows the maximum number of each item.

—: N/A

Function	Item	Maximum number	
		Learning machine	Inspection machine
User account	Number of user account settings (per license)	16 ^{*1}	16 ^{*1}
Project	Number of project settings (per license)	16	16
	Number of member settings (per project)	16	16
Data set	Number of data set settings (per project)	16	—
	Number of label settings (per data set)	16	—
	Number of label settings (per image)	1	—
	Number of images for which pixel marking is set (per data set)	100	—
	Number of images that can be registered (per server)	2,560,000	—
	Number of images that can be registered (per project)	160,000	—
	Number of images that can be registered (per data set)	10,000	—
AI model	Number of images that can be registered (per label)	10,000	—
	Number of AI model settings (per project)	16	—
	Number of images for learning (per AI model)	10,000 ^{*2}	—
Task	Number of AI models that can be learned simultaneously (per learning machine)	8 ^{*3*4}	—
	Number of task settings (per project)	16	16
	Number of tasks that can be executed simultaneously (per learning machine or inspection machine)	4	4
	Number of cameras that can be connected simultaneously (per learning machine or inspection machine)	8	8
	Number of programmable controllers that can be connected simultaneously (per learning machine or inspection machine)	8	8

*1 It is the total number of administrative users and standard users.

*2 The following conditions need to be satisfied:

- Available memory capacity is 4 GB or more when using an AI model for anomaly detection.
- Image size is 2.5 MB or less.

*3 Includes the turn ON of the trial mode.

*4 Learning can be performed up to four times simultaneously using the same AI engine type.

3.2 Image Data Specifications

This section shows the specifications of an image that can be used in each function.

—: N/A

Function	Item	Specification	
		Learning machine	Inspection machine
Data set	Format of images data that can be registered	jpg, jpeg, png, bmp	—
AI model	Format of image data for learning	jpg, jpeg, png, bmp	—
Task	Format of available image data	jpg, jpeg, png, bmp	—

4 PROCEDURE BEFORE OPERATION

This chapter shows the procedure from start-up to operation of this product.

Exclusion setting with antivirus software

Antivirus software may affect the operation of this product. Therefore, exclude the following folders from monitoring targets in the antivirus software setting:

For the setting method, refer to the manual for each antivirus software.

- Installation folder of this product
- C:\ProgramData\MELSOFT\AIVI

4.1 Starting Using this Product with the Development License

This section shows the procedure for starting using this product by registering the development license.

When a temporary license included in the installer is registered, steps 4 and later can be performed even before obtaining or registering the development license. For details on licenses, refer to the following:

☞ Page 19 Licenses

—: No operation required

Step	Learning machine	Operation terminal
1	Install this product with an installer. ☞ MELSOFT VIXIO Installation Instructions	—
2	Fill in the required information in the license application form to apply for the development license. ☞ Page 26 Registration Procedure for a License ☞ MELSOFT VIXIO License Application Instructions	
3	Register the development license in License Manager. ☞ Page 35 License Manager	
4	Start this product using the startup tool. ☞ Page 28 Startup Procedure for this Product	
5	—	Open the operation screen of this product. ☞ Page 29 Procedure for Opening the Operation Screen
6		Register (sign up) the administrative user. ☞ Page 31 Signing up
7		Create a project. ☞ Page 49 Creation Procedure for a Project
8		Create user accounts as necessary. ☞ Page 44 Creation Procedure for a User Account
9		Prepare image data for learning. For available image data formats, refer to the following: ☞ Page 20 Image Data Specifications Image data can also be prepared by creating a task for image data collection and collecting image data. ☞ Page 24 Collecting image data
10		Create a data set by registering image data and adding labels. In addition, perform pixel marking on images as necessary to specify defect locations on the images. ☞ Page 59 Creation Procedure for a Data Set
11		Set learning contents (such as a data set, preprocessing, and an AI engine) of an AI model and generate the AI model. ☞ Page 76 Creation Procedure for an AI Model
12		Set a threshold while checking the validation result of the AI model. ☞ Page 79 Validating an AI model
13		Create a task by setting processing blocks, a task flow, etc. ☞ Page 107 Creation Procedure for a Task
14		Start the created task. ☞ Page 163 Operation Procedure for a Task
15		Check the execution status of the task and inspection results. ☞ Page 167 Task Monitor Screen ☞ Page 171 Inspection Result History Check Screen

Collecting image data

The following shows the procedure for preparing image data using a task.

1. Creating a task for data collection

Set a camera for capturing images and an inspection result history (such as the saving destination of image data). (☞ Page 107 Creation Procedure for a Task)

Ex.

Example of a task for data collection (selecting the imaging block in the inspection result history setting)

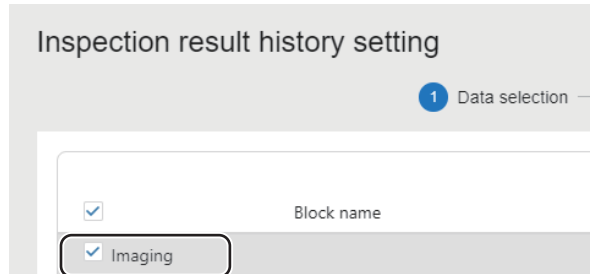
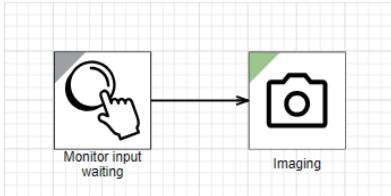

2. Executing the task

Start the created task and save image data. (☞ Page 163 Starting a task)

Ex.

Clearing the pause state of the task flow in the task monitor screen at the timing of capturing an image (☞ Page 164 Checking a task status)

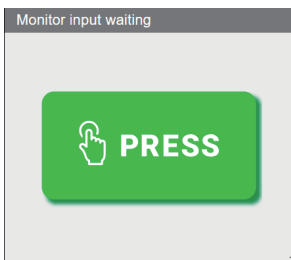

3. Downloading image data

Download image data, which is saved by the imaging block, from an inspection result history. (☞ Page 171 Inspection Result History Check Screen)

The screenshot shows a table titled 'History list' with a date range of '2023/09/20 13:20:42 to 2023/09/20 13:21:23'. The table has four columns: 'Index', 'StartTime', 'imaging_ImportedImage', and 'TotalImageSize(KB)'. There are three rows of data, each with a checked checkbox in the 'Index' column.

Index	StartTime	imaging_ImportedImage	TotalImageSize(KB)
0000	2023/09/20 13:20:42.081		13669
0001	2023/09/20 13:21:12.378		13669
0002	2023/09/20 13:21:14.774		13669

4.2 Starting Using this Product with the Run-time License

This section shows the procedure for starting using this product by registering the run-time license.

When a temporary license included in the installer is registered, steps 4 and later can be performed even before obtaining or registering the run-time license. For details on licenses, refer to the following:

☞ Page 19 Licenses

—: No operation required

Step	Inspection machine	Operation terminal
1	Install this product with an installer. ☞ MELSOFT VIXIO Installation Instructions	—
2	Fill in the required information in the license application form to apply for the run-time license. ☞ Page 26 Registration Procedure for a License ☞ MELSOFT VIXIO License Application Instructions	
3	Register the run-time license in License Manager. ☞ Page 35 License Manager	
4	Start this product using the startup tool. ☞ Page 28 Startup Procedure for this Product	
5	—	Open the operation screen of this product. ☞ Page 29 Procedure for Opening the Operation Screen
6		Register (sign up) the administrative user. ☞ Page 31 Signing up
7		Create a project. ☞ Page 49 Creation Procedure for a Project
8		Create user accounts as necessary. ☞ Page 44 Creation Procedure for a User Account
9		Perform any of the following operations to create a task. <ul style="list-style-type: none"> • Deploying an AI model generated with the development license and then setting processing blocks, a task flow, etc. (☞ Page 80 Deployment Procedure for an AI Model, Page 107 Creation Procedure for a Task) • Deploying a created task (☞ Page 115 Deployment Procedure for a Task)
10		Start the created task. ☞ Page 163 Operation Procedure for a Task
11		Check the execution status of the task and inspection results. ☞ Page 167 Task Monitor Screen ☞ Page 171 Inspection Result History Check Screen

5 BASIC OPERATIONS

This chapter shows the basic operations of this product.

5.1 Registration Procedure for a License

The following shows the procedure for registering a license.

Procedure for registering a temporary license

The following shows the procedure for registering a temporary license.

Operating procedure

1. Start License Manager from the startup tool. (☞ Page 33 Startup tool)
2. Click the [Register] button in the [License List] tab of License Manager. (☞ Page 35 License Manager)
3. Select 'learn_trial.elic' stored in the 'TempLicense' folder in the installation folder of this product, and click the [Open] button.

Procedure for registering a license other than a temporary license

The following shows the procedure for registering a license other than a temporary license.

Operating procedure

1. Check the entitlement ID shown in the Entitlement ID Notification.

When renewing the development license, check also the entitlement ID in use which is displayed in "Entitlement ID" in the [License List] tab of License Manager.

2. Start License Manager from the startup tool. (☞ Page 33 Startup tool)
3. Check the hardware code displayed in "Hardware code" in the [Activation information] tab of License Manager. (☞ Page 35 License Manager)

This step is not required for a renewal application.

4. Access the web form for issuing licenses, then enter the following information and apply for the license.
 - Entitlement ID
 - Entitlement ID in use (for a renewal application)
 - Hardware code (for a new application)
 - User information (company name, customer name, phone number, address, e-mail address, and others)

For details on the web form for issuing licenses, refer to MELSOFT VIXIO License Application Instructions.

5. Save the license file sent to the entered e-mail address into the folder of a registration destination (learning machine or inspection machine).
6. Click the [Register] button in the [License List] tab of License Manager.

Point

When a temporary license is in use, delete the license before registering the development or run-time license.

7. Select the license file saved in step 5, and click the [Open] button.

Precautions

- Be sure to enter the correct e-mail address carefully to receive a license file without fail.
- Do not change the license file extension (.elic).
- Use this product with a temporary license while waiting for a license issuance after the application. If a temporary license expires before obtaining a license, contact your local Mitsubishi Electric sales office or representative to reissue a temporary license.
- Make sure that the clock setting on Windows is correct before registering a license file for the first time. If the time on Windows is shifted forward or backward for 24 hours or more after a license file is registered, the license authentication will fail.

5.2 Startup Procedure for this Product

This section shows the procedure for starting this product.

Operating procedure

1. Start the startup tool. (📖 Page 33 Startup tool)
2. Click  (Start operation) to switch the operation status to "RUN."



Point

- The display language of the startup tool follows the language setting of the operating system.
- The operation status of this product can be checked with the icon on the task tray.

: RUN

: STOP

Changing operation status

The operation status of this product can be switched with  (Start operation) or  (Stop operation).

If a server certificate does not exist when changing the status to "RUN," the certificate will be generated. After the certificate is generated, the following message appears. Click the [Yes] button to install it.

If the server certificate is expired (365 days after it is generated), the certificate is generated again even when it already exists. When using an operation terminal in a different environment with the learning or inspection machine, copy the folder in which the server certificate is stored into the operation terminal and install the certificate. (📖 Page 30 Installing a server certificate)



Point

Note that the server certificate must be generated again when the IP address of the server is changed. Click  (Start operation) to generate the certificate again.

5.3 Procedure for Opening the Operation Screen

This section shows the procedures for opening the operation screen of this product.

Considerations

The following shows the considerations for opening the operation screen.

- If the operation status of this product is "STOP," the operation screen cannot be opened. In this case, switch the status to "RUN" in the startup tool, then open the operation screen.
- If the port number for this product is used by another application, the operation status of this product is switched to "STOP" and the operation screen cannot be opened. In this case, change the port number and switch the operation status to "RUN" in the startup tool, then open the operation screen. (Another application may be using the port number that is set by default for this product after installation.)

☞ Page 33 Startup tool

- Depending on a web browser, its translation function may be displayed when the operation screen is opened. To switch the display language, do not use the translation function but use the personal setting screen.

☞ Page 176 PERSONAL SETTINGS

Displaying a web browser

This product accesses the operation screen from a web browser.

In the same environment as the learning machine or inspection machine

A web browser can be displayed by either of the methods shown below:

- Displaying from the task tray (☞ Page 29 Displaying from the task tray)
- Displaying from the startup tool (☞ Page 29 Displaying from the startup tool)

Point

The default web browser on Windows is used.

■ Displaying from the task tray

Right-click the icon of this product from the task tray, and select [Open].

■ Displaying from the startup tool

1. Start the startup tool. (☞ Page 33 Startup tool)
2. Click  (Open in browser).

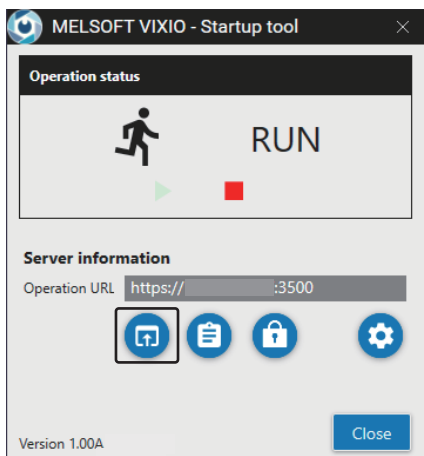

In a different environment from the learning machine or inspection machine

A web browser can be displayed by the method shown below:

1. Install a server certificate on an operation terminal. (👉 Page 30 Installing a server certificate)

When the server certificate is already installed, this step is not required.

Point

The server certificate must be installed on an operation terminal to connect it to the learning machine or inspection machine in secured communication.

Even without the server certificate, operations can be performed in unsecured communication; however, the communication may be disturbed or information may be stolen by a malicious user.

To install the server certificate on an operation terminal with Android or iOS, contact its sales agency for the installation method.

2. Start the startup tool in the learning machine or inspection machine. (👉 Page 33 Startup tool)
3. Enter an operation URL, which is shown in the startup tool, in the address bar of a web browser on the operation terminal.

Point

An operation URL can be copied to the clipboard by clicking  (Copy to clipboard).

■ Installing a server certificate

The following shows the procedure for installing a server certificate on an operation terminal.

Operating procedure

1. Copy the server certificate folder of the learning machine or inspection machine to the operation terminal.
 - Server certificate folder: (Installation destination of this product)\AIVICert
2. Execute 'install_cert.bat' in the 'AIVICert' folder with the administrator authority on the operation terminal.

Signing up

The following shows the screen displayed when starting this product for the first time.

This is the screen for registering (signing up) the administrative user*1 who uses this product by entering a user ID and password.

*1 For details on the administrative user, refer to the following:

☞ Page 43 User types

After sign-up, the project management screen is displayed with the screen for creating a new project.

☞ Page 49 Creating a new project

☞ Page 55 Project Management Screen

Window

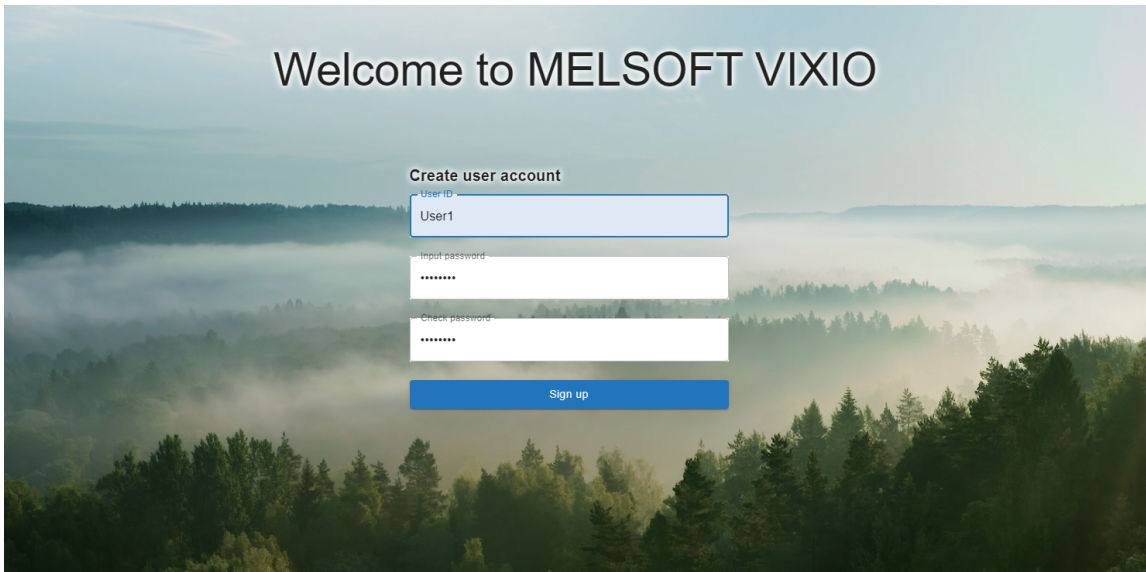

5

Displayed items

Item	Description
User ID	Enter a user ID (1 to 32 characters). ^{*2}
Input password	Enter a password (8 to 64 characters). ^{*2}
Check password	Enter the password again for verification. ^{*2}
[Sign up] button	Click this to sign up for this product as the administrative user who uses this product with the entered user ID and password.

*2 Alphabetical characters are case-sensitive.

Point

- This screen is displayed when starting this product for the first time (when the administrative user is not registered). From the next time (after the administrative user is registered), the sign-in screen is displayed. (☞ Page 32 Signing in)
- When user information is signed up, a user is signed in to this product. A user remains signed in until the set auto sign-out time elapses. (☞ Page 176 PERSONAL SETTINGS)
- To add more users, create user accounts in the user management screen after sign-in. (☞ Page 44 Creation Procedure for a User Account)

Signing in

The following shows the screen displayed when starting this product (after the administrative user is registered). This is the screen for signing in to this product by entering a user ID and password. After sign-in, the project management screen is displayed.

 Page 55 Project Management Screen

Window

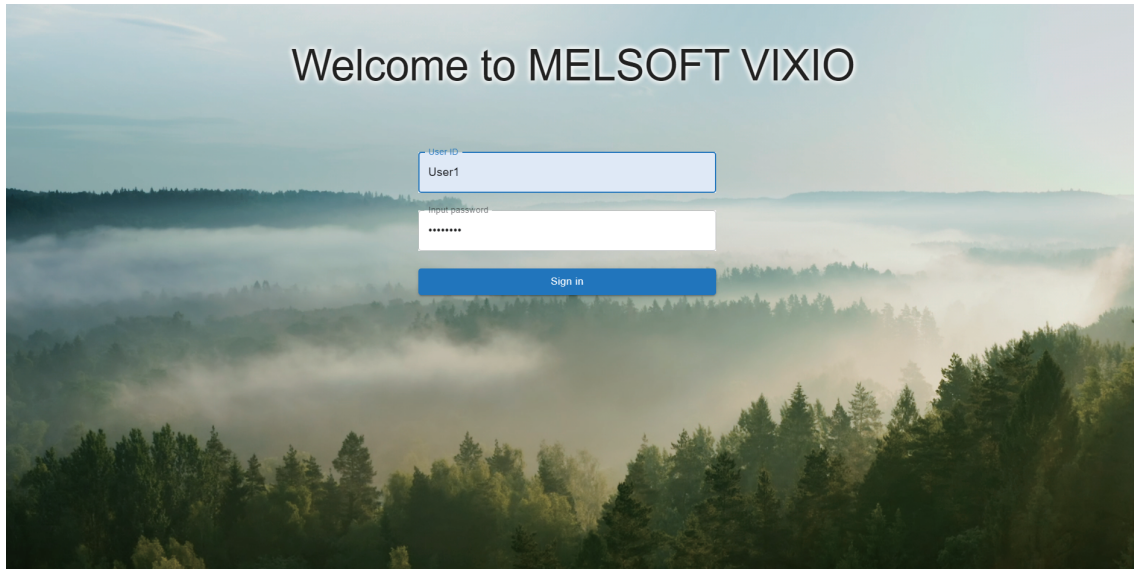

Displayed items

Item	Description
User ID	Enter a user ID (1 to 32 characters). ^{*1}
Input password	Enter a password (8 to 64 characters). ^{*1}
[Sign in] button	Click this to sign in to this product with the entered user ID and password.

^{*1} Alphabetical characters are case-sensitive.

Point

- A user remains signed in until the set auto sign-out time elapses. ( Page 176 PERSONAL SETTINGS)
- When a signed-in user is already signed in in another environment (another personal computer or another web browser), sign-in in a new environment is enabled and the user is signed out in another environment.
- When another user is already signed in on another tab or window of the same browser, the sign-in of the newly signed in user is enabled and the already signed in user is signed out. Note that the sign-in information of the already signed in user remains displayed until the browser is refreshed.

5.4 Screen Configuration

Startup tool

The following shows the tool that controls the start or stop of this product.

It can perform the following operations: changing the operation status of this product, configuring the auto start setting, and configuring settings for connecting to the operation screen.

License Manager can also be started from this tool.

Window

Right-click the icon of this product from the task tray, and select [Setting].

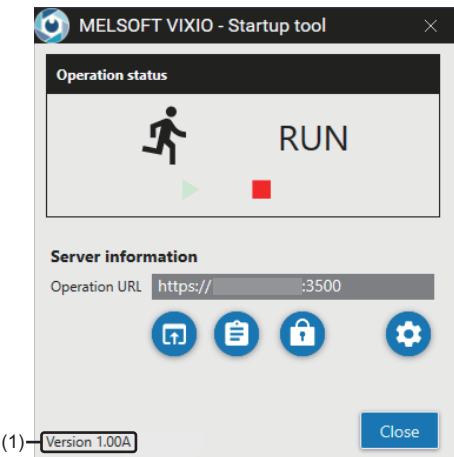

Displayed items

Item	Description	
Operation status	The operation status of this product is displayed. (☞ Page 28 Changing operation status) <ul style="list-style-type: none"> • RUN: This product is running. • STOP: This product is stopped. 	
Server information	Operation URL	A URL to open the operation screen of this product is displayed.
	(Open in browser)*1	Click this to open the operation screen of this product in the default web browser on Windows.
	(Copy to clipboard)	Click this to copy the operation URL to the clipboard.
	(Start license manager)	Click this to start License Manager. (☞ Page 35 License Manager)
	(Connection Setting)	Click this to configure connection settings and the auto start setting. (☞ Page 34 Setting) is displayed if a set value is not available.
(1) Product version	The version of this product is displayed.	

*1 Can be clicked when the operation status is "RUN."

Precautions

The operation screen of this product opens by right-clicking the icon of this product from the task tray and selecting [Open].

(☞ Page 31 Signing up, Page 32 Signing in)

However, [Open] cannot be selected when the operation status of this product is 'STOP.'

Setting

The following shows the screen for configuring connection settings and the auto start setting.

Window

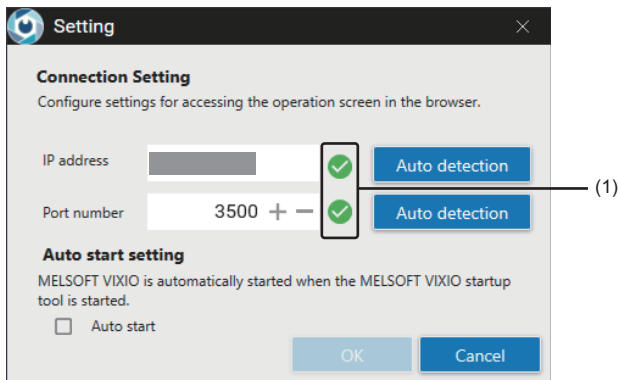

Displayed items

Item		Description
Connection Setting* ¹	—	To configure settings for accessing the operation screen from a web browser
	IP address	Set an IP address (0.0.0.0 to 255.255.255.255). To access from another operation terminal, an IP address that is accessible from the operation terminal must be set.
	Port number	Set a port number (0 to 65535).
	(1) Availability	Whether the set IP address or port number is available is displayed. <ul style="list-style-type: none"> • : Usable • : Unusable
	[Auto detection] button	<p>■ IP address Click this to set the default IP address linked to a computer name. When the default IP address cannot be acquired, set '127.0.0.1.'</p> <p>■ Port number Click this to detect unused port numbers in the range of 1024 to 65535 and set the minimum port number among the detected ones.</p>
Auto start setting* ¹	Auto start	Select the checkbox to change the operation status of this product automatically while the product is running. (Page 34 Auto start)

*1 The settings can be configured only when the operation status of this product is "STOP."

■ Auto start

When the auto start setting is enabled, the startup tool is started at Windows logon*¹ and the operation status of this product is automatically changed to "RUN."

To perform the auto start by turning ON the power of a personal computer, the automatic logon must be enabled in Windows.

*1 Depending on the sign-in option settings of Windows, this product is started and the auto start is performed on the Windows lock screen. Therefore, in some cases, the sign-in screen can be accessed from the operation screen at when the Windows lock screen is displayed.

License Manager

The following shows License Manager used to register and delete licenses of this product or check their status.

For the procedure for registering a license, refer to the following:

☞ Page 26 Registration Procedure for a License

To use this product immediately before obtaining the development or run-time license, register a temporary license.

To keep using this product after the temporary license has expired, obtain and register the development or run-time license.

For the license types, refer to the following:

☞ Page 19 Licenses

Precautions

- Make sure that the clock setting on Windows is correct before registering a license file for the first time. If the time on Windows is shifted forward or backward for 24 hours or more after a license file is registered, the license authentication will fail.
- The license expires on the expiration date. The expiration date is displayed in local time according to the time zone. The license expiration is checked by using UTC time as a standard. Therefore, it is not affected by daylight saving time. (For a temporary license, it will expire on the next day of the date when the license expiration date becomes less than one day (at 0:00:00 in local time).)

Window

Click  (Start license manager) in the startup tool. (☞ Page 33 Startup tool)

Point

The display language of License Manager follows the language setting of the operating system.

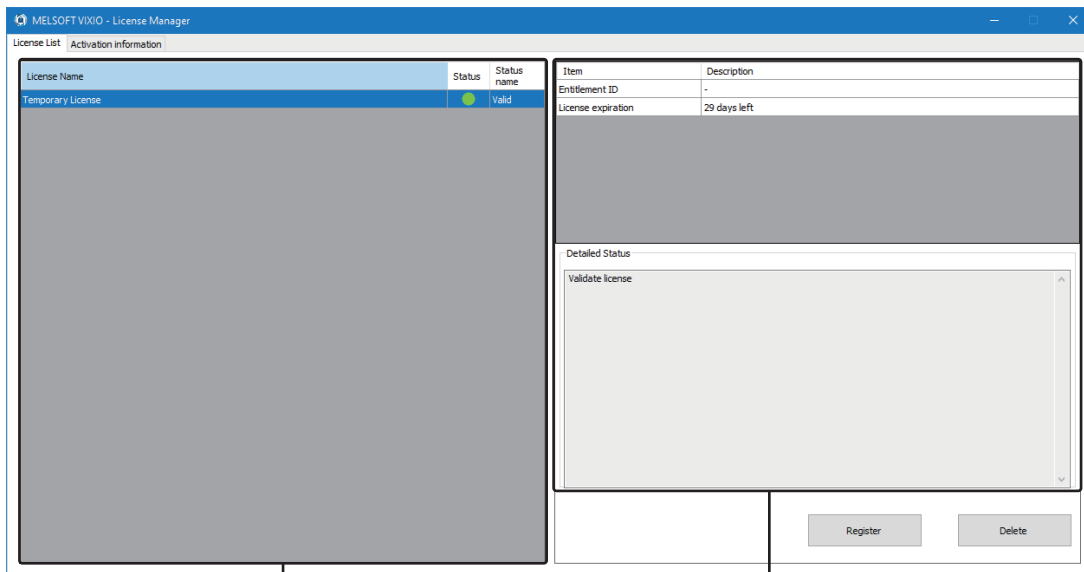

- (1) License list
- (2) Detailed information

Displayed items

Item		Description
[License List] tab	(1) License list	Registered licenses and their statuses are displayed. Only one license can be registered. ■License name The name of a license is displayed. ■Status/Status name The status of a license is displayed. <ul style="list-style-type: none"> • "Valid": License is valid. • "Invalid": License is invalid.
	(2) Detailed information	The detailed information of a license is displayed. ■Entitlement ID The entitlement ID of a license is displayed. "-" is displayed in either of the following cases: <ul style="list-style-type: none"> • A temporary license is used. • The entitlement ID cannot be read from a license file. ■License expiration The expiration date of a license is displayed. <ul style="list-style-type: none"> • Temporary license When more than one day remains, "XX days left" (XX: Remaining days - 1) is displayed. When less than one day remains, "Less than one day left" is displayed. Otherwise, "-" is displayed. • Development license The expiration date (local time) is displayed in the "YYYY/MM/DD hh:mm" format. If the expiration date cannot be read from the license file, "-" is displayed. • Run-time license "None" is displayed. ■Detailed status An error description is displayed when "Status name" is "Invalid." (Page 37 Error description) "Validate license" is displayed when "Status name" is "Valid." Otherwise, "-" is displayed.
	[Register] button	Click this to register a license file or renew a registered license file. For the procedure for obtaining and registering a license, refer to the following: Page 26 Registration Procedure for a License
	[Delete] button	Click this to delete the selected license.*1
[Activation information] tab	Hardware code	The code created based on the hardware-specific information necessary for application of a license file is displayed.
	[Copy] button	Click this to copy a hardware code to the clipboard.

*1 A license needs to be deleted when moving its registered license file to another personal computer.

Error description

The following table shows the error descriptions displayed in "Detailed status" and the corrective actions when "State name" is "Invalid."

Error code	Error description	Cause	Corrective action
210018	There is a problem in the registered license file.	A license file issued for another personal computer is specified.	Register the correct license file issued for the personal computer in use.
		After registering a license file for the first time to the personal computer in use, the date and time was changed and the time on Windows was shifted before the license issue date and time.	Change the time on Windows to the time after the license issue date and time.
210026	The time of Windows has been changed.	<ul style="list-style-type: none"> After registering a license file for the first time to the personal computer in use, the date and time was changed and the time on Windows was shifted forward or backward for 24 hours or more. Antivirus software locks a license file temporarily. 	Exclude the installation folder of this product from monitoring targets in the antivirus software setting. For the setting method, refer to the manual for each antivirus software. If the symptom cannot be solved by the above corrective action, contact your local Mitsubishi Electric sales office or representative.
210037	The license has been expired.	The temporary license expired.	Contact your local Mitsubishi Electric sales office or representative to obtain a new license, and register the license.
214109		The development license expired.	
Other error codes	A system error occurred.	Errors that seem not to occur in actual operation occurred due to an internal operation of the software.	Contact your local Mitsubishi Electric sales office or representative to obtain a new license, and register the license.

Operation screen

This chapter shows the operation screen of this product.

Window

For the procedure for opening the operation screen, refer to the following:

☞ Page 29 Procedure for Opening the Operation Screen

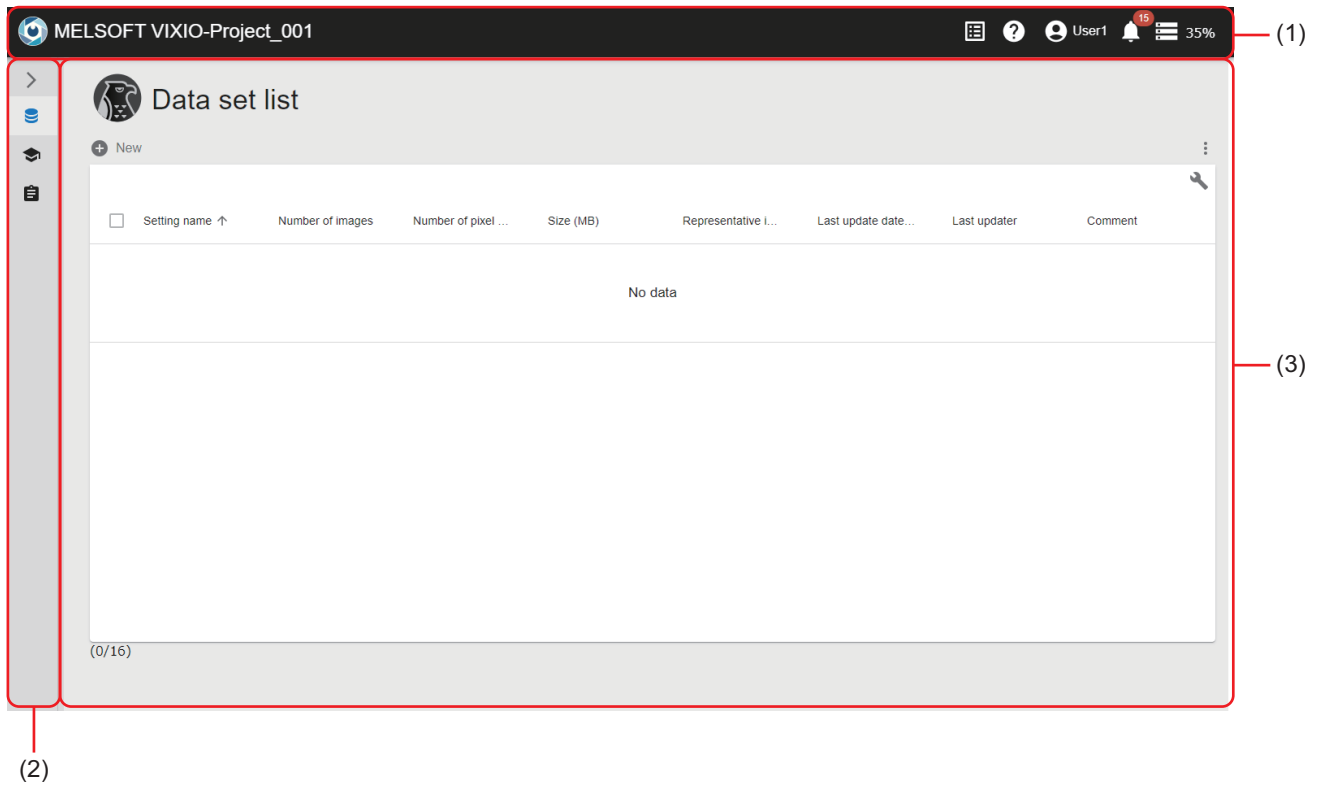

- (1) Main bar (☞ Page 39 Main bar)
- (2) Side bar (☞ Page 40 Side bar)
- (3) Content area (☞ Page 41 Content area)

Main bar

This is an area displayed at the top of the following screens:

- User management screen
- Personal setting screen
- Project management screen
- Data set management screen/Data set setting screen
- AI model management screen/AI model setting screen/AI model validation screen
- Task management screen/Task setting screen

Point

The following screens can be displayed from the main bar: Project management screen, user management screen, personal setting screen, and event/error history screen.

Displayed items



Item	Description
(Product logo)	Click this to open the project management screen. ☞ Page 55 Project Management Screen
(1) Product name-project name	"MELSOFT VIXIO" and the name of an open project are displayed. Click this to open the project management screen. ☞ Page 55 Project Management Screen
(Project)	Click this to open the project management screen. ☞ Page 55 Project Management Screen
(Help)	Click this to display the help menu. <ul style="list-style-type: none"> • Open manual: To display the manual for this product in another tab • Open MITSUBISHI ELECTRIC FA Global Website: To display the MITSUBISHI ELECTRIC FA Global website in another tab.*1 • Open version information: To display the version information.
(2) User ID	The ID of a signed-in user is displayed. The following menus are displayed by clicking the ID. <ul style="list-style-type: none"> • Personal setting: To open the personal setting screen. (☞ Page 176 PERSONAL SETTINGS) • User management: To open the user management screen. (☞ Page 47 User Management Screen) • Sign out: To sign out from this product.
(Notify)	Among events or errors that occurred in a project to which a signed-in user is allowed access, the events or errors that are not checked by the user are notified. (Maximum 1,000 notifications) The number of notifications is displayed on the upper right of the icon. (If there are 100 or more notifications, "99+" is displayed.) ☞ Page 40 Notification list
(3) Storage usage rate	The storage usage rate of the learning machine or inspection machine being accessed is displayed.*2 An icon and a usage rate are displayed as follows according to the storage usage rate: <ul style="list-style-type: none"> 76% : 0% to 79% 80% : 80% to 89% 90% : 90% to 100% In addition, the storage information and the resource information of CPU/GPU can be checked with a tooltip.*3

*1 When setting a language other than Japanese for a display language, the MITSUBISHI ELECTRIC FA Global website is displayed in English.

*2 The information of a drive where this product is installed is displayed.



*3 The GPU memory information is displayed when a command line utility for managing NVIDIA GPU devices is available. When the utility is not available, "-" is displayed for the GPU memory information.

■ Notification list

Among events or errors that occurred in a project to which a signed-in user is allowed access, the events or errors that are not checked by the user are notified. (Maximum 1,000 notifications)





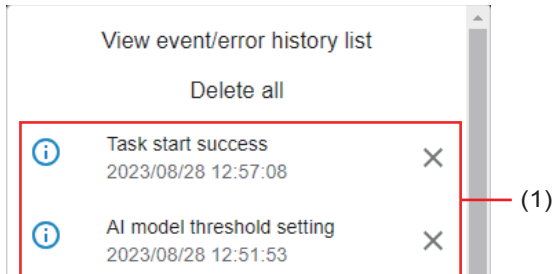

When the number of notifications exceeds 1,000, up to 1,000 notifications are displayed from the newest one.

Window

Click  (Notify) on the main bar. ( Page 39 Main bar)



Displayed items

Item	Description
[View event/error history list] button	Click this to display the event/error history screen in another tab.  Page 173 EVENT/ERROR HISTORY CHECK
(1) Notification list	Events or errors that are not checked by the user are displayed. <ul style="list-style-type: none"> • : Information • : Warning • : Error By clicking a notification, the event/error history screen which displays the details of a corresponding event or error is displayed in another tab.*1  Page 173 EVENT/ERROR HISTORY CHECK A notification is deleted from the list by clicking  (Delete).
[Delete all] button	Click this to delete all notifications.

*1 The clicked notification will be deleted from the notification list.









Side bar

This is an area displayed in the left part of the following screens when a project is open.

Icons for transitioning to respective management screens (data sets, AI models, tasks) are displayed.

- Data set management screen/Data set setting screen
- AI model management screen/AI model setting screen/AI model validation screen
- Task management screen/Task setting screen

Displayed items

Item	Description
 (Expand)/  (Collapse)	Click this to expand or collapse the side bar.
 (Data set)	Click this to open the data set management screen.  Page 65 Data Set Management Screen
 (AI model)	Click this to open the AI model management screen.  Page 83 AI Model Management Screen
 (Task)	Click this to open the task management screen.  Page 118 Task Management Screen

Content area

This is an area where contents of a screen are displayed.

■ Expanding the header

The following operations can be performed by clicking  (Expand) for expanding the header.

- Searching
- Switching to show or hide
- Filtering

Searching

Lines including an entered character string can be searched for. (Characters are not case-sensitive.)

Data in all columns is searched including hidden columns.

Ex.

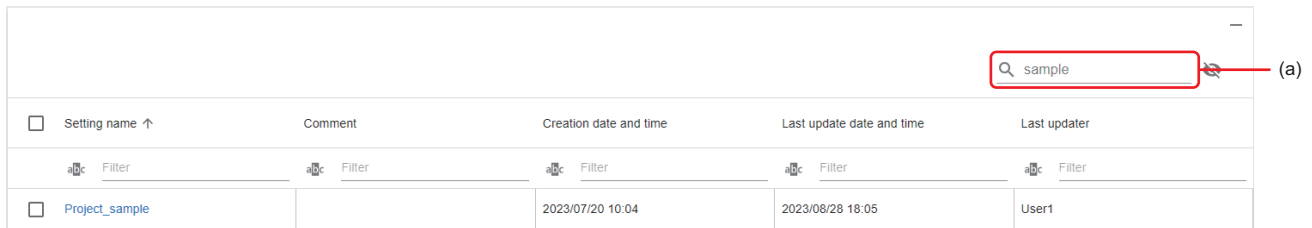

The screenshot shows a table with a search bar at the top right containing the text "sample". A red box highlights the search bar, and a red arrow labeled "(a)" points to the expand icon to its right. The table has five columns: "Setting name", "Comment", "Creation date and time", "Last update date and time", and "Last updater". Each column has a "Filter" button below its header. The first row of data is "Project_sample" with a creation date of "2023/07/20 10:04", an update date of "2023/08/28 18:05", and the updater "User1".

<input type="checkbox"/> Setting name ↑	Comment	Creation date and time	Last update date and time	Last updater
<input type="checkbox"/> Project_sample		2023/07/20 10:04	2023/08/28 18:05	User1

(a) Enter a character string.

Switching to show or hide

A column can be shown or hidden.

Select the checkboxes of columns to be shown, and unselect the ones to be hidden.

Ex.

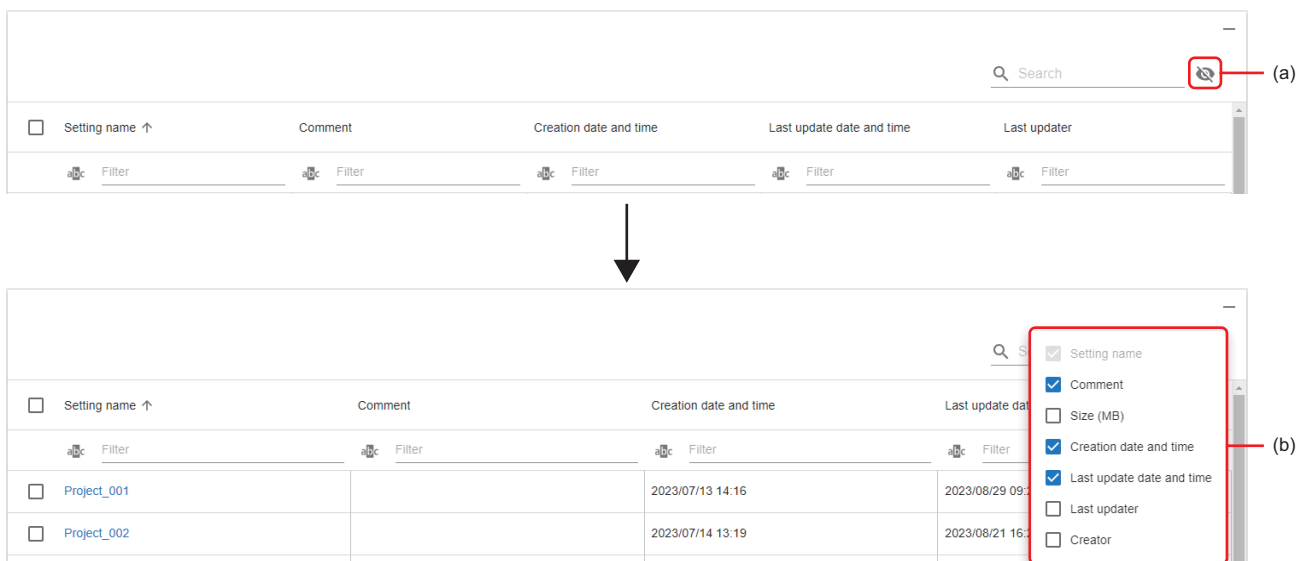

The top screenshot shows the same table as above, but with a red box around the expand icon and a red arrow labeled "(a)" pointing to it. A downward arrow indicates the next step. The bottom screenshot shows the table with a dropdown menu open on the right side. The dropdown menu has a red box around it and a red arrow labeled "(b)" pointing to it. The dropdown menu contains the following items: "Setting name" (unchecked), "Comment" (checked), "Size (MB)" (unchecked), "Creation date and time" (checked), "Last update date and time" (checked), "Last updater" (unchecked), and "Creator" (unchecked). The table data is now: "Project_001" (2023/07/13 14:16, 2023/08/29 09:30) and "Project_002" (2023/07/14 13:19, 2023/08/21 16:30).

<input type="checkbox"/> Setting name ↑	Comment	Creation date and time	Last update date and time	Last updater
<input type="checkbox"/> Project_001		2023/07/13 14:16	2023/08/29 09:30	
<input type="checkbox"/> Project_002		2023/07/14 13:19	2023/08/21 16:30	

(a) Click .

(b) Select the checkbox of a column to be shown, and unselect the one to be hidden.

Filtering

Lines can be filtered by setting a condition and character string. (Characters are not case-sensitive.)

Ex.

Setting name	Comment	Creation date and time	Last update date and time	Last updater
Filter	Filter	2023/07/13 14:16	2023/08/29 09:20	User1
Filter	Filter	2023/07/14 13:19	2023/08/21 16:29	User1
Filter	Filter	2023/08/01 14:54	2023/08/28 12:51	User1
Filter	Filter	2023/08/28 18:43	2023/08/29 09:20	User1

Setting name	Comment	Creation date and time	Last update date and time	Last updater
Project_sample	Filter	2023/07/20 10:04	2023/08/28 18:05	User1

- (a) Click the filter icon.
- (b) Specify a condition.
- (c) Enter a character string.

Closing the operation screen

The operation screen can be closed by closing the browser or tab where the operation screen is opened.

Considerations

■ When a network failure occurs

When a network failure occurs between an operation terminal and the learning machine or inspection machine, the request that is sent just before the failure (such as starting learning and starting a task) continues to be processed without interruption. After the failure is recovered, acquire the latest information of the learning machine or inspection machine by refreshing the browser on the operation terminal, and restart the operation.

■ When operating screens

This product does not support to operate screens using multiple tabs on a web browser to be used. The operation is not guaranteed when operating screens with multiple tabs open (excluding a tab that is opened when executing a function such as task monitor).

■ When terminating an operation screen

When learning is being performed or any tasks is running, the processing continues in the background even after the operation screen is closed.

To prevent processing from continuing in the background, stop learning or the task before closing the operation screen.

6 USER ACCOUNT

This chapter explains user accounts.

User types

The following table shows the type of user accounts.

Type	Description	Maximum number of settings
Administrative user	A user account that can access all projects and has the administrator authority. The following operations can be performed in the user management screen: adding and deleting a user account, changing ^{*1} a user type, and setting access authority for a standard user.	16 (The total number of administrative users and standard users)
Standard user	A user account that can access specific projects. Only browsing is allowed in the user management screen.	

*1 The user type of the user itself cannot be changed.

Precautions

Data cannot be restored if all users forget a password.

It is recommended to backup data frequently by using the export function.

 Page 51 Exporting and Importing Procedure for a Project

6.1 Creation Procedure for a User Account

This section shows the procedure for creating a user account.

1. Create a new user account. ( Page 44 Creating a new user account)
2. Set access authority for a user account ( Page 45 Setting access authority for a user account)

Creating a new user account

The following shows the procedure for creating a new user account.

Operating procedure

1. Click the [New] button in the user management screen. ( Page 47 User Management Screen)

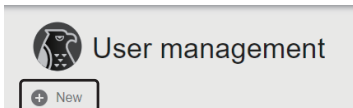

2. Set the user account information, and click the [OK] button.

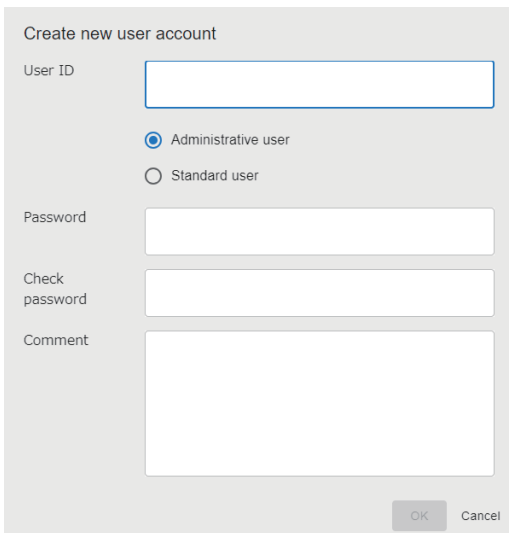
A screenshot of a dialog box titled "Create new user account". It contains several input fields: "User ID" (a text box), "Administrative user" (selected radio button), "Standard user" (unselected radio button), "Password" (a text box), "Check password" (a text box), and "Comment" (a larger text area). At the bottom right, there are "OK" and "Cancel" buttons.

Item	Description
User ID	Set a user ID (1 to 32 characters).
Administrative user/Standard user	Select a user type.
Password	Set a password (8 to 64 characters).
Check password	Enter the password again for verification.
Comment	Set a comment (0 to 1024 characters).

Setting access authority for a user account

The following shows the procedure for setting the access authority of a standard user to each project.

For details on access authority, refer to the following:

Page 46 Access authority

Operating procedure

1. Select a standard user in the user management screen, and click the [Authority setting] button. (Page 47 User Management Screen)

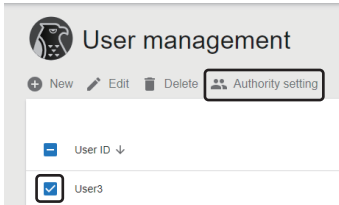

2. Select a project to which the user is allowed access, and turn ON the access authority setting switch as indicated in (1).

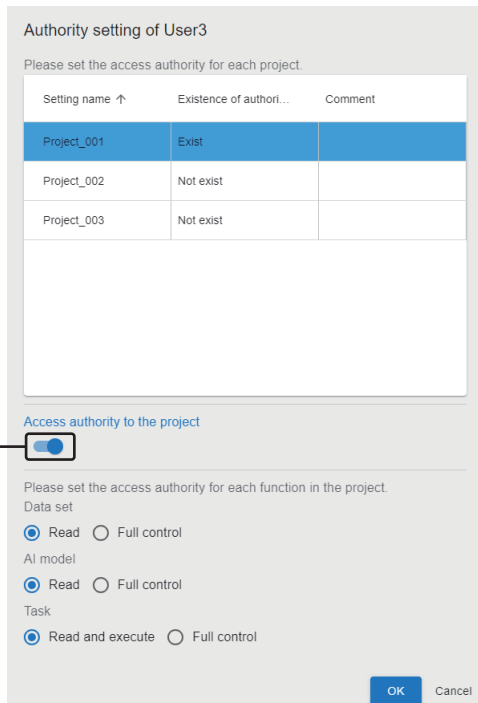

3. Set access authority for each setting (data sets, AI models, and tasks), and click the [OK] button.*1

*1 For the run-time license, access authority cannot be set to data sets and AI models.



Access authority can also be set for a project from member settings. (Page 50 Setting Members)

Access authority

The following shows the types of access authority.

Access authority to project	Access authority to each setting	Description
Authorized	Full control (Data set, AI model, and task)	All contents of a project can be browsed and any operations can be performed in the project.* ¹
	Read (Data set and AI model)	A partial content of a project can be browsed.* ²
	Read and execute (Task)	A partial content of a project can be browsed and some operations can be performed for the project.* ^{2*3}
Not authorized		A project cannot be browsed.

*¹ For a standard user, some items cannot be browsed and operated. ( Page 46 Menu display for access authority)

*² The following screens can be browsed:

For data sets: Management screen and property

For AI models: Management screen, property, and AI model validation screen

For tasks: Management screen, property, task monitor screen, inspection result history check screen, and auto start setting screen.

*³ The following operations can be performed: starting and stopping tasks.

■ Menu display for access authority

Menu items displayed in each management screen (data sets, AI models, and tasks) differ depending on the type of access authority and a user.

—: Not displayed, ○: Displayed

Item	Access authority		
	Read/Read and execute	Full control (standard user)	Full control (administrative user)
New	—	○	○
Edit	—	○	○
Duplicate	—	○	○
Delete	—	○	○
AI model validation	○	○	○
Start	○	○	○
Stop	○	○	○
Task monitor	○	○	○
Auto start setting	○	○	○
Inspection result history	○	○	○
Import	—	—	○
Export	—	—	○
Deploy	—	○	○
Property	○	○	○

Point

Some settings and items cannot be browsed and operated depending on the license type. For details, refer to the following:

 Page 19 Operations available for each license

6.2 User Management Screen

This section shows the screen for creating and managing user accounts.

Window

Click a user ID on the main bar, and select [User management]. (📖 Page 39 Main bar)

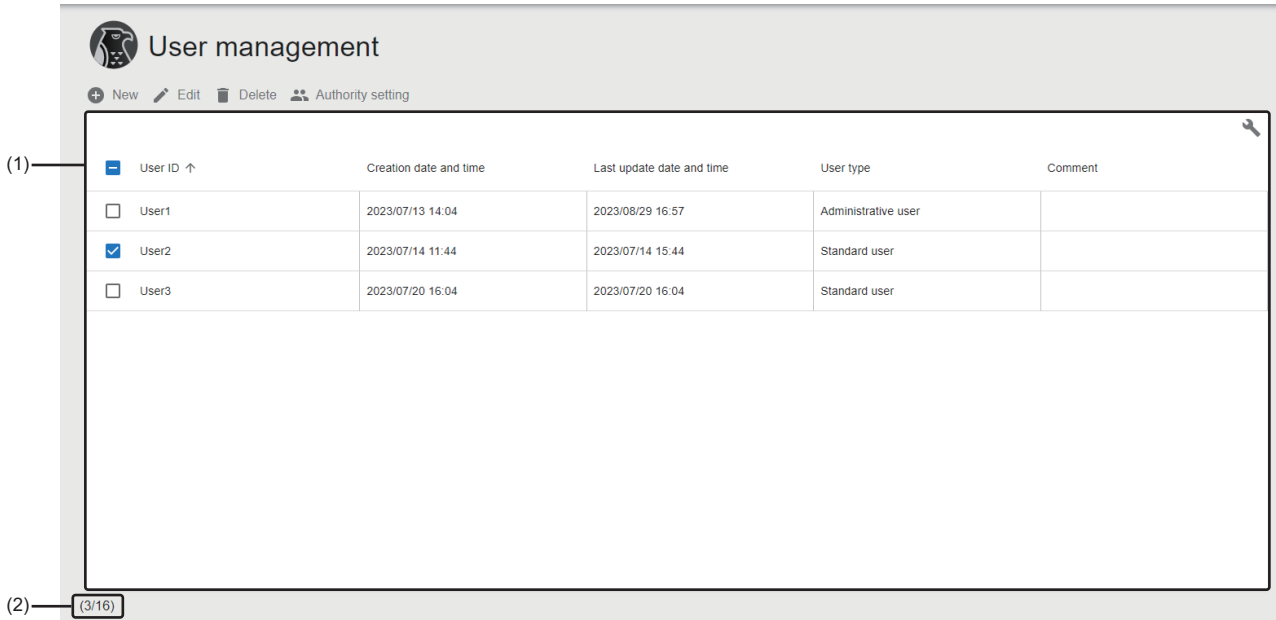

Displayed items

Item	Description	
New	Click this to create a new user account. 📖 Page 44 Creating a new user account	
Edit	Click this to edit the information of the selected user account. 📖 Page 48 Editing a user account	
Delete	Click this to delete the selected user account.	
Authority setting	Click this to set access authority for the selected user account (a standard user). 📖 Page 45 Setting access authority for a user account	
(1) User account list	User ID	A user ID is displayed.
	Creation date and time	The date and time when a user account was created is displayed.
	Last update date and time	The date and time when user account information was last updated is displayed.
	User type	A user type is displayed. (📖 Page 43 User types)
	Comment	A set comment is displayed.
(2) Number of settings	The number of created user accounts and the maximum number of user accounts that can be created are displayed.	

Editing a user account

The following shows the procedure for editing the user account information.

Window

Select a user account in the user management screen, and click the [Edit] button. (☞ Page 47 User Management Screen)

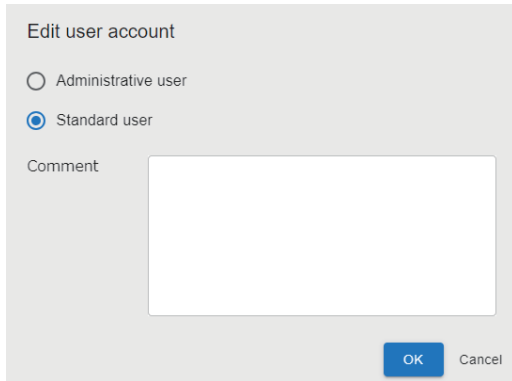

Edit user account

Administrative user

Standard user

Comment

OK Cancel

Displayed items

Item	Description
Administrative user/Standard user	Select a user type.*1
Comment	Set a comment (0 to 1024 characters).

*1 The user type of the user itself cannot be changed.

7 PROJECT

This chapter explains projects.

A series of data required for learning and inspection is managed in each 'project.'

Users who can access a project can be set by configuring member settings. In addition, authority to access each setting (data sets, AI models, and tasks) can be set for a user. (👉 Page 50 Setting Members)

Projects are managed individually in both of the learning machine and inspection machine. However, editing learning-related functions is restricted in the inspection machine.

Multiple users can operate a project and each setting of the project at the same time. A message appears if the project and its settings become inoperative while the operation conflicts with another operation.

7.1 Creation Procedure for a Project

This section shows the procedure for creating a project.

1. Create a new project. (👉 Page 49 Creating a new project)
2. Set project members. (👉 Page 50 Setting Members)

Creating a new project

The following shows the procedure for creating a new project.

A created project can be accessed only by the administrative user and a user who created the project.

7

Point

- A created project can also be duplicated.
👉 Page 55 Project Management Screen
- Users to be allowed to access a project can be added in member settings.
👉 Page 50 Setting Members

Operating procedure

1. Click the [New] button in the project management screen. (👉 Page 55 Project Management Screen)

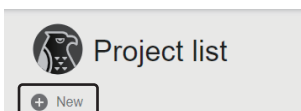

2. Set the project information, and click the [OK] button.

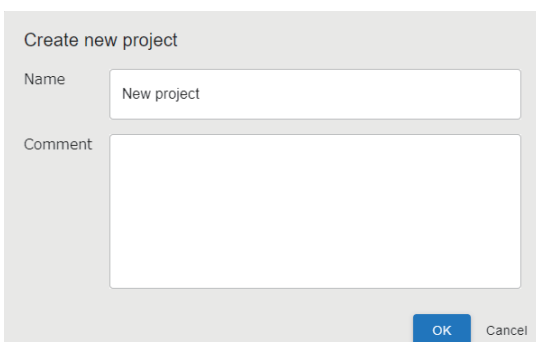
A screenshot of a "Create new project" dialog box. It has a title bar "Create new project". Below the title bar, there are two input fields: "Name" with the text "New project" and "Comment" with a large empty text area. At the bottom right, there are two buttons: "OK" and "Cancel".

Item	Description
Name	Set a project name (1 to 32 characters).
Comment	Set a comment (0 to 1024 characters).

Setting Members

This section shows the procedure for setting users who can access a project.

Only the administrative user can set members. (📖 Page 43 User types)

In addition, the administrative user can set the access authority of a member for each project setting (data sets, AI models, and tasks).

For details on access authority, refer to the following:

📖 Page 46 Access authority

Operating procedure

1. Select a project in the project management screen, and click the [Member] button. (📖 Page 55 Project Management Screen)

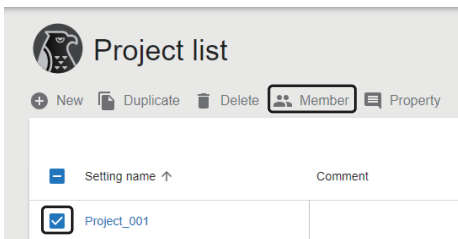

2. Select a user who is allowed to access the project and turn ON the access authority setting switch as indicated in (1).

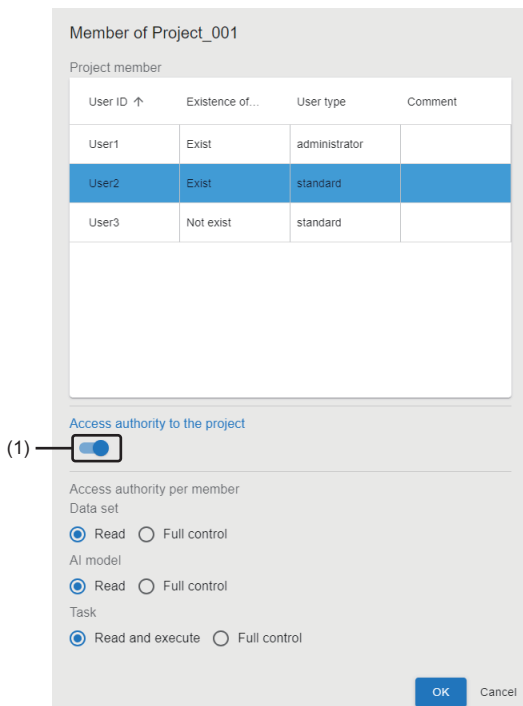

3. Set access authority for each setting (data sets, AI models, and tasks), and click the [OK] button. *1*2

*1 The access authority of the administrative user cannot be changed from "Full control."

*2 For the run-time license, access authority cannot be set to data sets and AI models.

Point

Access authority can also be set for a project from the user management screen. (📖 Page 45 Setting access authority for a user account)

7.2 Exporting and Importing Procedure for a Project

This section shows the procedure for using a created project in another environment by exporting and importing the project. A project can be exported and imported into another environment as a new project or as settings of an existing project. Only the administrative user can export or import projects using any of the following screens:

- Project management screen
- Data set management screen
- AI model management screen
- Task management screen

Point

- Data must be exported or imported in a project unit even when exporting or importing only a setting (data sets, AI models, or tasks).
 - A project file is not protected by a password when exporting it. Project files can be imported without limitation in the environment where this product can be used. Therefore, the files must be handled carefully.
-

Export

The following shows the procedure for exporting a project by using the project management screen as an example.

Operating procedure

1. Select a project in the project management screen, click  (Other options), and select [Export]. ( Page 55 Project Management Screen)

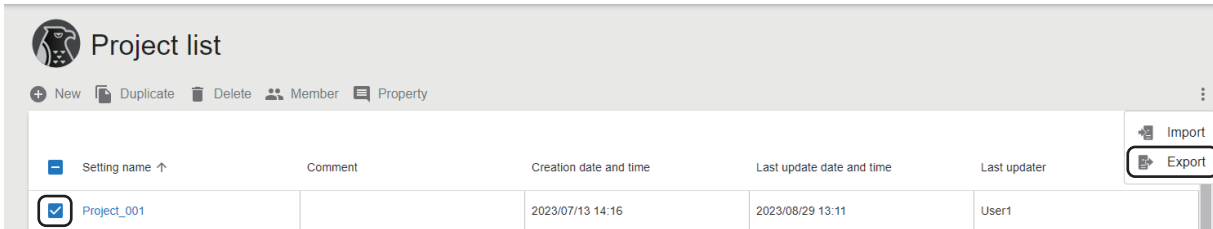

2. Select the checkbox of data to be exported, and click the [OK] button.

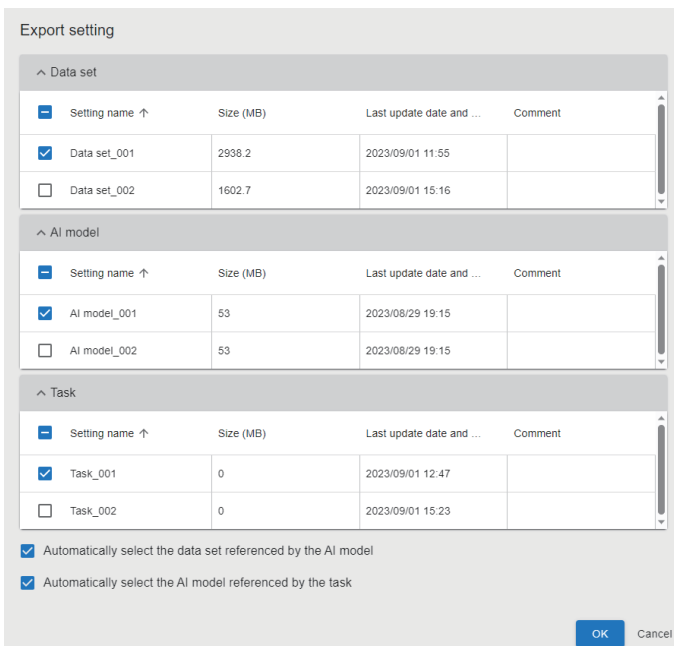

3. Click the [OK] button.

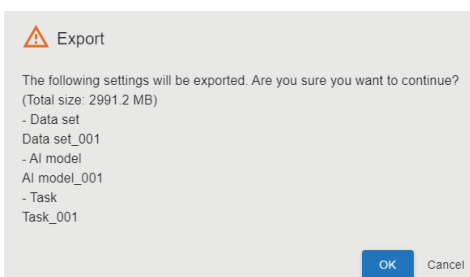

A project file with the name '((project name).avi)' is exported.



Point

- A project file is output by the download function of a web browser.
- Windows has a limit of the path length; therefore, a file name is shortened by a web browser. In addition, when a shortened file name is duplicate, the name is also changed according to the specifications of the web browser function.

Import

The following shows the procedure for importing a project by using the project management screen as an example.

Operating procedure

1. Click  (Other options), and select [Import] in the project management screen. ( Page 55 Project Management Screen)

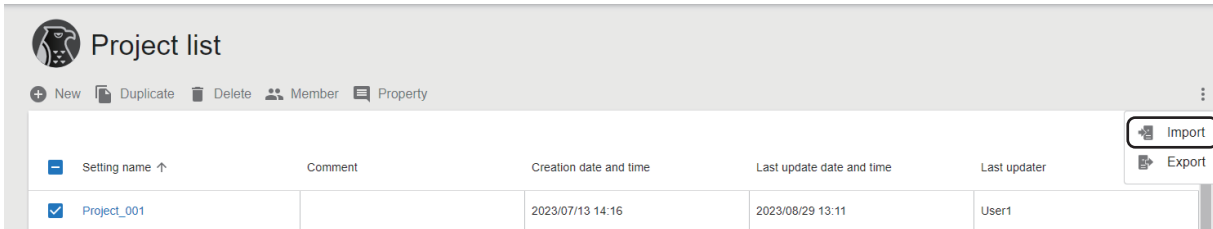

2. Select a project file ((project name).aivi) to be imported, and click the [Open] button.
3. Select the method for importing the project file, and click the [OK] button.

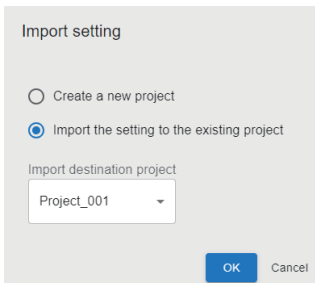

Item	Description
Create a new project* ¹	Select this to create a new project which includes settings of an import target.
Import the setting to the existing project	Select this to create settings of an import target as new settings in a project selected in "Import destination project."* ²

*1 Cannot be selected when the number of projects in the project management screen reaches the maximum.

*2 When importing settings from a screen other than the project management screen, an open project is set for "Import destination project."

Point

After importing a project, it is recommended to change its task name to the name which is unique to the import source project and import destination project.

The inspection result history of a task is saved into a folder with the name of the task. Therefore, the inspection result history of a corresponding task can be easily identified from its folder name even when using settings including the inspection result history setting as they are (except for the task name).

Precautions

■ When importing a project file exported without including settings which are referenced by each setting (data sets, AI models, and tasks)

When a data set referenced by an AI model is not included

- The status of the imported AI model becomes the same as that of when the model is exported.
- Reference to the data set is deleted in the imported AI model. (It is not referenced even when a data set with the same name exists in the import destination.)
- The following information related to the data set is deleted:
 - AI model management screen: "Data set name" and "Data at AI model generation"
 - AI model validation screen: "Data set" in 'Detailed information' and "File name" and "Label name" in 'Inference result.'

When an AI model referenced by a task is not included

- The status of the imported task becomes 'Editing' regardless of the status when the task is exported.
- Reference to the AI model is deleted in the imported task. (It is not referenced even when an AI model with the same name exists in the import destination.)
- The AI model setting of the AI model execution block is changed to an unconfigured state.

■ When importing a project file including settings referenced by each setting (data sets, AI models, and tasks)

- To import a project file including the referenced settings, these settings must also be selected together with the project file when exporting the file. Note that the settings are not referenced on import when exporting each of the settings individually.
- When a data set referenced by an AI model is imported to the import destination where the same data set name exists, the imported data set name is renamed. The imported AI model refers to the renamed data set.
- When an AI model referenced by a task is imported to the import destination where the same AI model name exists, the imported AI model name is renamed. The imported task refers to the renamed AI model.



■ When closing the browser while importing a file

Importing an import target file fails if reading the file is not completed.

7.3 Project Management Screen





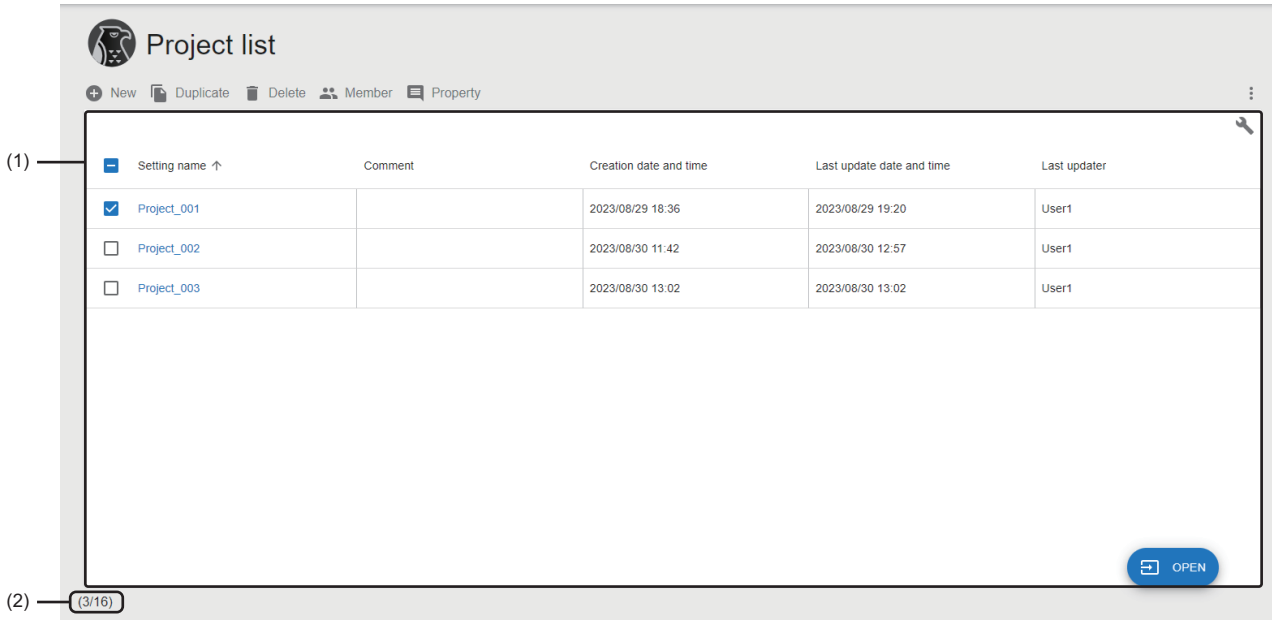

This section shows the screen for creating and managing projects.

Window

Click a product name (-project name) on the main bar or  (Project). ( Page 39 Main bar)



Displayed items

Item	Description
New	Click this to create a new project.  Page 49 Creating a new project
Duplicate	Click this to duplicate a selected project. For the contents of the duplicated project, refer to the following:  Page 56 Behavior when duplicating a project If the duplication fails when multiple projects are selected, the duplication of a project which failed to be duplicated and subsequent projects will be canceled. (If the number of projects after duplication exceeds the maximum number, the duplication of all projects will be canceled.)
Delete	Click this to delete a selected project. Even if the deletion fails when multiple projects are selected, the projects will be deleted except the failed ones.
Member	Click this to set members of a selected project. ( Page 50 Setting Members)
Property	Click this to check or change the properties of a selected project.  Page 57 Project properties
 (Other options)	Import Click this to import a project created in another personal computer. Settings that are already created in a project will not be deleted even if the import fails during the process.  Page 53 Import
	Export Click this to export a project so that it can be utilized in other personal computers.  Page 52 Export

Item	Description	
(1) Project list* ¹	Setting name	A project name is displayed. The following screen appears by clicking a project name. <ul style="list-style-type: none"> Development license: Data set management screen (☞ Page 65 Data Set Management Screen) Run-time license: Task management screen (☞ Page 118 Task Management Screen)
	Comment	A set comment is displayed.
	Size* ²	The file size* ³ of a project is displayed.
	Creation date and time	The date and time when a project was created is displayed.
	Last update date and time	The last date and time when a project was updated is displayed. The latest one among the following dates and times is displayed: <ul style="list-style-type: none"> Time when a project was newly created The latest one among the update time of a user account*⁴, data set, AI model, or task (including that of when a project was imported) Time when a user account, data set, AI model or task was deleted This item is not updated by the following operations: <ul style="list-style-type: none"> Editing the name or comment for a project Exporting a project Editing the name or comment of a data set, AI model, and task When duplicating a project, the last update date and time is inherited from the duplicate source project. (After that, the date and time is updated according to the update status of the duplicated project.)
	Last updater	The ID of a user who last updated a project is displayed.
	Creator* ²	The ID of a user who created a project is displayed.
[Open] button	<ul style="list-style-type: none"> For the development license: Click this to open the data set management screen of the selected project. (☞ Page 65 Data Set Management Screen) Run-time license: Click this to open the task management screen of the selected project. (☞ Page 118 Task Management Screen) 	
(2) Number of settings	The number of created projects and the maximum number of projects that can be created are displayed.	

*¹ Projects to which the user is not authorized to access are grayed out.

*² Displayed by expanding the header.

☞ Page 41 Expanding the header

*³ This is the sum of data size of settings (data sets, AI models, and tasks) included in a project.

*⁴ Time when either of the following operations is performed is displayed:

-Adding or deleting a member

-Changing settings of a user in a member group

Behavior when duplicating a project

Contents of a duplicated project are changed as follows:

Item	Description
Setting name	A three-digit number with zero padding is added to the end of the setting name of the duplicate source. The initial value '(001)' is added to the end of the setting name and it is incremented to prevent the name from being duplicated with other projects.* ¹ If the setting name exceeds the maximum number of characters (32 characters) after duplication, characters after the first 27 characters are deleted from the name and the number is added.
Creation date and time	It is changed to the date and time when the project is duplicated.
Others	They are not changed from the duplicate source.

*¹ Characters are not case-sensitive when checking duplication of names.

Project properties

The following operations can be performed: changing the name and comment of a project and checking the property information.

Window

Select a project in the project management screen, and click the [Property] button. (☞ Page 55 Project Management Screen)

Property of Project_001	
Name	Project_001
Comment	
Creation date and time	2023/07/13 02:16
Last update date and time	2023/08/29 01:11
Size (MB)	6103.6
Last updater	User1
Creator	User1

Displayed items

Item	Description
Name	Set a project name (1 to 32 characters).
Comment	Set a comment (0 to 1024 characters).
(1) Property information	The property information of a project is displayed.

8 DATA SET

This chapter explains data sets.

Data sets can be used only with the development license.

8.1 Data Set

A data set is a group of image data (and information) required for generating an AI model.

It is created by registering image data, adding labels, and setting pixel marking according to the intended use of an AI model to be generated.

Labels

Image data can be managed by adding labels to the data to categorize it into groups (learning or validation) and to distinguish defective or non-defective products according to the inspection purpose.

Adding labels is required regardless of an AI engine^{*1} to be used.

*1 An AI engine is a system that learns image data to generate an AI model. For details, refer to the following:

☞ Page 73 AI engine

Inspection purpose	Example of a label to be set
Determining defective products	Add labels such as 'Non-defective product' and 'Normal product' for the image data of the prepared non-defective products. For the image data of defective products, add labels such as 'Defective product' and 'Abnormal product.'
Identifying error locations	Add labels such as 'Scar' and 'Dirt' according to an error type. (After adding labels, set pixel marking for each piece of image data.)

Pixel marking

Pixel marking is used for distinguishing between normal and error locations on images of defective products.

It is required when using an AI engine for 'Defective point detection.'

8.2 Creation Procedure for a Data Set

This section shows the procedure for creating a data set.

1. Create a new data set. (👉 Page 59 Creating a new data set)
2. Set a data set. (👉 Page 60 Setting a data set)

Creating a new data set

The following shows the procedure for creating a new data set.



A data set can also be created by duplicating a created data set.
👉 Page 65 Data Set Management Screen

Operating procedure

1. Click the [New] button in the data set management screen. (👉 Page 65 Data Set Management Screen)

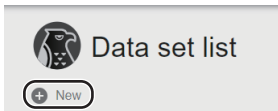

2. Set the data set information, and click the [OK] button.

Create new data set

Name

Comment

Item	Description
Name	Set a data set name (1 to 32 characters).
Comment	Set a comment (0 to 1024 characters).

Setting a data set

Registering image data to be used for generating an AI model, adding labels, and setting pixel marking (as necessary) are required.

The following shows the procedure for setting a data set.

Operating procedure

1. Select a target data set in the data set management screen, and click the [Edit] button. (☞ Page 65 Data Set Management Screen)

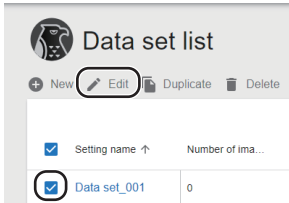

2. Register image data. (☞ Page 61 Registering image data)
3. Add labels. (☞ Page 62 Adding labels)
4. Set pixel marking. (☞ Page 63 Setting pixel marking)

Registering image data

The following shows the procedure for registering image data to be used for a data set when generating an AI model.

Operating procedure

1. Select a label to be added to image data in "Label" of the data set setting screen. (☞ Page 68 Data Set Setting Screen)

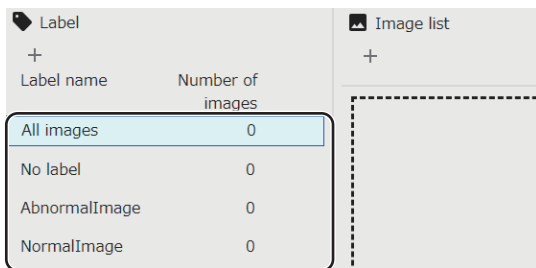

2. Click + (Add) in "Image list," and select [Select folder] or [Select file] to import an image file(s).

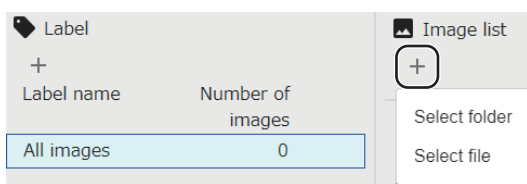

Point

An image file(s) or a folder can be imported by dragging and dropping it (them).

3. When selecting "All images" in the label list, select whether to add labels to the image data, and click the [Add] button.

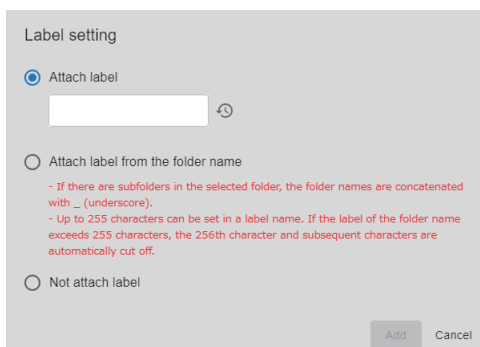

Item	Description
Attach label	Select this to add a label to the imported image data. Click 🔄 and select a label to be added to the image data. A new label can be added by entering a label name (1 to 255 characters) in the text box.
Attach label from the folder name ^{*1}	Select this to add the selected folder name as the label name of the imported image data.
Not attach label	Select this to add labels to the imported image data later.

*1 Can be selected when a folder is to be imported.

Precautions

When image data with the same name is already registered, the four-digit numbers which are not duplicated with others are added to the end of the file name to be registered.

Adding labels

The following shows the procedure for adding labels to the registered image data.

It is not required when labels were already added at the time when the image data is registered.

Operating procedure

■ Adding a label

The following shows the procedure for adding labels to be added to image data.

1. Click **+** (Add) in "Label" of the data set setting screen. (☞ Page 68 Data Set Setting Screen)

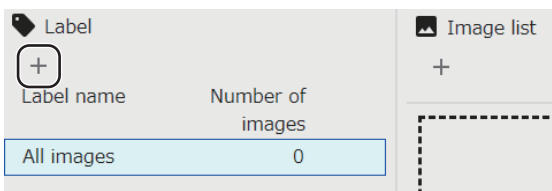

2. Set a label name (1 to 255 characters), and click the [Add] button.

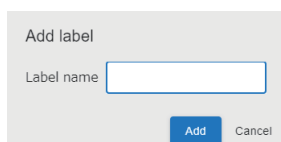

■ Selecting a label

The following shows the procedure for adding the added labels to image data.

1. Click **🕒** in the data set setting screen and select a label to be added. (☞ Page 68 Data Set Setting Screen)

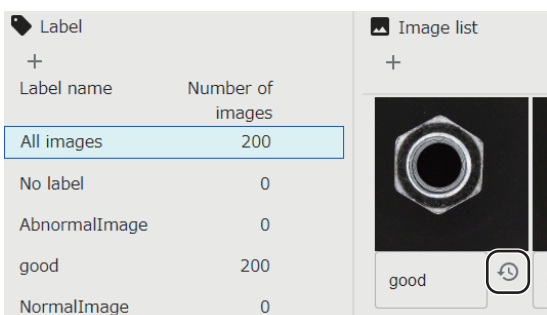

Setting pixel marking

The following shows the procedure for setting normal and error locations by drawing dots on image data. This is to detect error locations using AI.

Error locations can be detected by marking only a few pixels on the normal and error locations of image data.

Operating procedure

1. Click image data for which pixel marking is to be set in "Image list" of the data set setting screen. (☞ Page 68 Data Set Setting Screen)

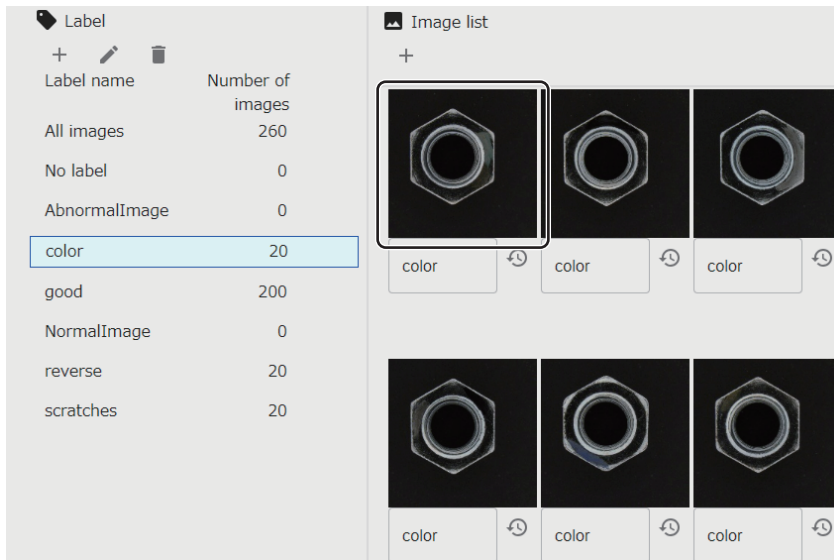

2. Turn ON "Pixel marking mode."

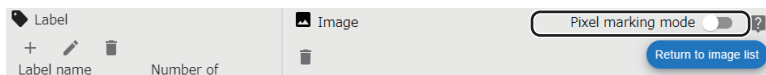

3. Select the type of pixel marking (normal location or error location).

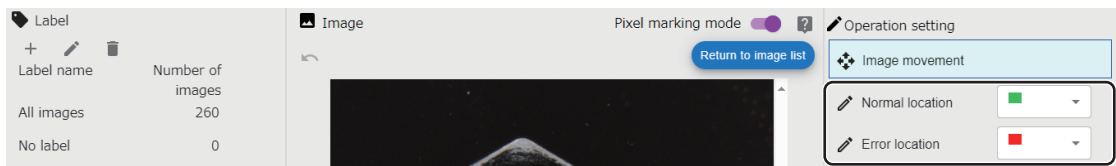

4. Draw dots on the image data by clicking or dragging on the image.

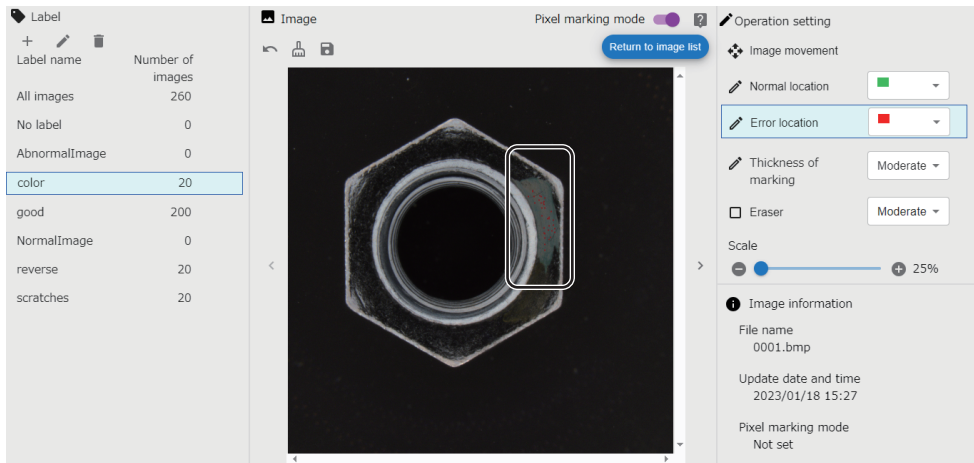

Point

Up to 5,000 dots can be drawn on each piece of image data.



5. Click  (Save).



8.3 Data Set Management Screen





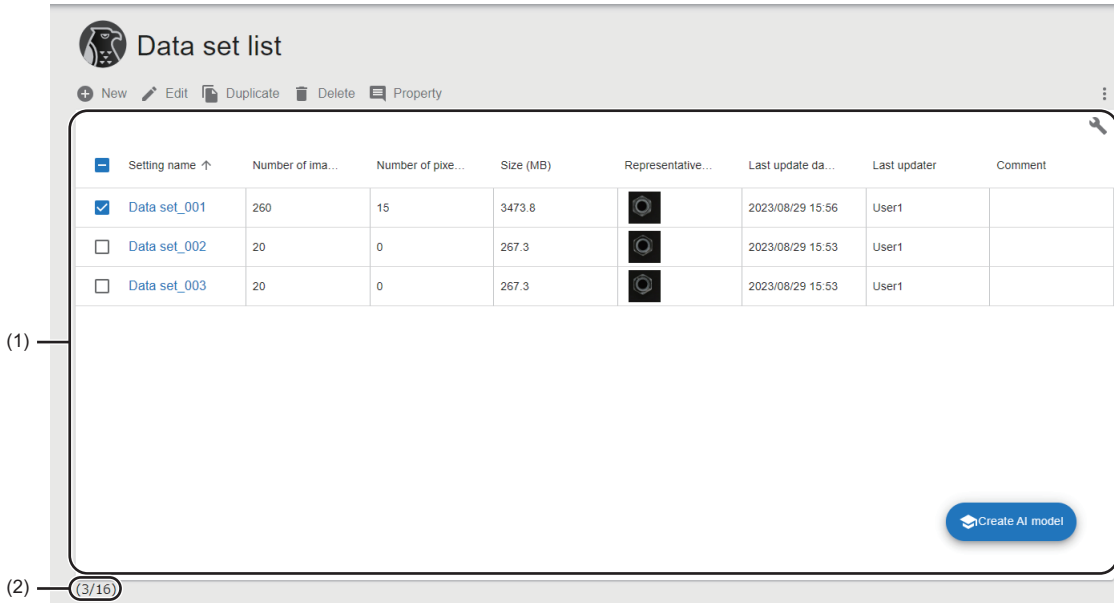

This section shows the screen for creating and managing data sets.

Window

Click  (Data set) on the side bar. ( Page 40 Side bar)



Displayed items

Item	Description
New	Click this to create a new data set.  Page 59 Creating a new data set
Edit	Click this to edit the selected data set.  Page 68 Data Set Setting Screen
Duplicate	Click this to duplicate the selected data set. For the contents of the duplicated data set, refer to the following:  Page 66 Behavior when duplicating a data set If the duplication fails when multiple data sets are selected, the duplication of a data set which failed to be duplicated and subsequent data sets will be canceled. (If the number of data sets after duplication exceeds the maximum number, the duplication of all data sets will be canceled.)
Delete	Click this to delete the selected data set. Even if the deletion fails when multiple data sets are selected, the data sets will be deleted except the failed ones.
Property	Select this to check or change the properties of the selected data set.  Page 67 Data set properties
⋮ (Other options)	Import Select this to import a data set created in another personal computer. Settings that are already created in a project will not be deleted even if the import fails during the process.  Page 53 Import
	Export Select this to export a data set so that it can be utilized in other personal computers.  Page 52 Export

Item	Description
(1) Data set list	
Setting name	A data set name is displayed. The data set setting screen appears by clicking the data set name.  Page 68 Data Set Setting Screen
Number of images	The number of images which have been registered in a data set is displayed.
Number of pixel marking settings	The number of images for which pixel marking is set in a data set is displayed.
Size (MB)	The file size ^{*1} of a data set is displayed.
Representative image	Among image data registered in a data set, the image data which has the latest update date and time is displayed.
Label name ^{*2}	A label name set in a data set is displayed.
Number of labels ^{*2}	The number of labels set in a data set is displayed.
Creation date and time ^{*2}	The date and time when a data set was created is displayed.
Creator ^{*2}	The ID of a user who created a data set is displayed.
Last update date and time	The last update date and time ^{*3} of a data set is displayed.
Last updater	The ID of a user who last updated a data set is displayed.
Comment	A set comment is displayed.
[Create AI model] button ^{*4}	Click this to create an AI model for which the selected data set is used.
(2) Number of settings	The number of created data sets and the maximum number of data sets that can be created are displayed.

*1 The file size is the same as that of a data set setting in a project file for export.

*2 Displayed by expanding the header.

 Page 41 Expanding the header

*3 It is not changed even when changing the properties.

*4 Displayed when one piece of image data or more is registered in the selected data set.

Behavior when duplicating a data set

Contents of a duplicated data set are changed as follows:

Item	Description
Setting name	A three-digit number with zero padding is added to the end of the setting name of the duplicate source. The initial value '(001)' is added to the end of the setting name and it is incremented to prevent the name from being duplicated with other data sets. If the setting name exceeds the maximum number of characters (32 characters) after duplication, characters after the first 27 characters are deleted from the name and the number is added.
Creation date and time	It is changed to the date and time when the data set is duplicated.
Others	They are not changed from the duplicate source.

Data set properties

The following operations can be performed: changing the name and comments of a data set and checking the property information.

Window

Select a data set in the data set management screen, and click the [Property] button. (☞ Page 65 Data Set Management Screen)

Property of Data set_001

Name : Data set_001

Comment :

(1)

Creation date and time : 2023/08/29 15:39
Update date and time : 2023/08/29 15:56
Size (MB) : 3473.8(MB)
Number of images : 260(Pieces)
Number of pixel marking settings : 15(Pieces)
Last updater : User1
Creator : User1

OK Cancel

Displayed items

Item	Description
Name	Set a data set name (1 to 32 characters).
Comment	Set a comment (0 to 1024 characters).
(1) Property information	The property information of a data set is displayed.

Point

The last update date and time of a data set is not changed even when changing a name and comment.

8.4 Data Set Setting Screen

This section shows the screen for registering, editing, or visualizing image data.





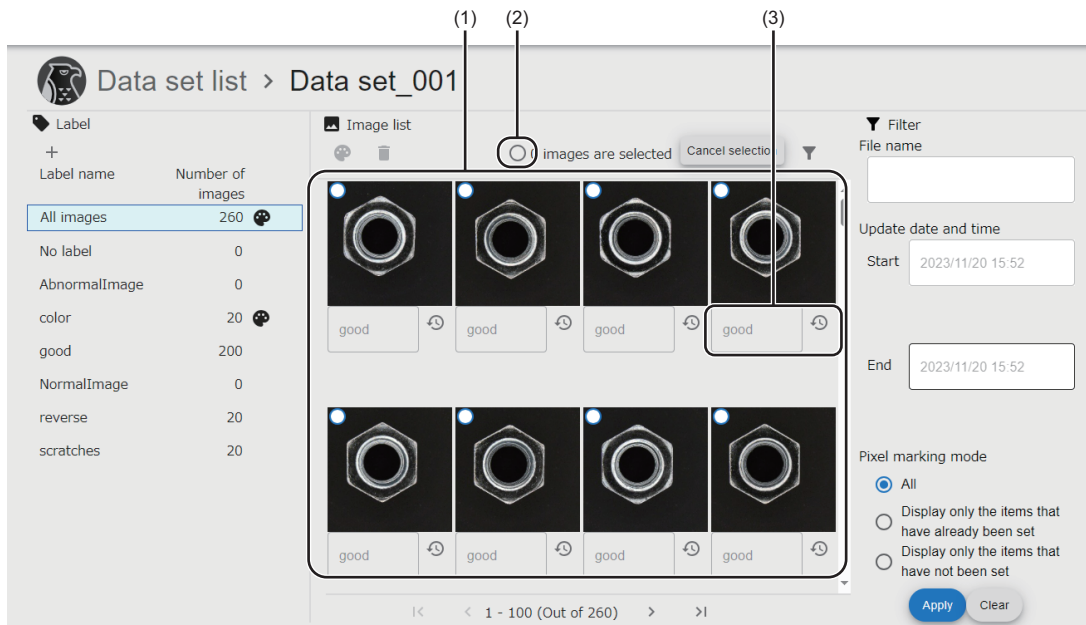





Window

Select a data set to be set in the data set management screen, and click the [Edit] button. (☞ Page 65 Data Set Management Screen)



Displayed items

Item	Description
Label	Image data displayed in the image list is switched by selecting a label name. An icon is displayed together according to the following cases: <ul style="list-style-type: none"> • 🟡: When image data for which pixel marking is set is included • 🔄: When image data is being registered or deleted
+	Click this to add a label(s) to be added to image data. (Up to 16 labels) ☞ Page 62 Adding a label
✎	Click this to edit the selected label name (1 to 255 characters).
🗑	Click this to delete the selected label.
⏹	Click this to cancel registering or deleting image data.

Item	Description	
Image list	 (Add) ^{*1}	Click this to register image data.  Page 61 Registering image data
	 (Pixel marking mode) ^{*2}	Click this to set pixel marking for the selected image data.  Page 63 Setting pixel marking
	 (Delete) ^{*2}	Click this to delete the selected image data.
	(2) Select all button ^{*2}	Select this to switch the selection status (all selected or not selected) of image data in all pages.
	[Select] button [Cancel selection] button	Click either of these buttons to enable or disable the selection of image data in the image list indicated in (1). <ul style="list-style-type: none"> • Select: To enable the image selection mode (a state where image data can be selected). • Cancel selection: To unselect image data in all pages and disable the image selection mode.
	 (Filter)	Click this to switch the display status of the input field for filtering conditions.
	(1) Image list	Image data is displayed in a list.  is displayed for image data for which pixel marking is set. By clicking a piece of image data when the image selection mode is disabled, the display is switched to the enlarged image display.  Page 70 Enlarged image display In the image selection mode, multiple pieces of image data can be selected by clicking each piece of the data with  held down.
(3) Label selection	Click  and select a label to be added to the image data. A new label can be added by entering a label name (1 to 255 characters) in the text box. When selecting multiple pieces of image data and adding a label with the text box, the label is added to all the selected image data.	
Filter	File name	Specify the file name of image data to be filtered.
	Update date and time	Specify the update date and time of image data. <ul style="list-style-type: none"> • Start: Specify an update date and time to search from. • End: Specify an update date and time to search to.
	Pixel marking mode	Specify the setting status of pixel marking. <ul style="list-style-type: none"> • All: All image data is displayed regardless of the setting status of pixel marking. • Display only the items that have already been set: Only image data with pixel marking settings is displayed. • Display only the items that have not been set: Only image data without pixel marking settings is displayed.
	[Apply] button	Click this to filter images by set conditions.
	[Clear] button	Click this to clear set conditions.

*1 Displayed when the image selection mode is disabled and when image data is not being registered or deleted.

*2 Displayed when the image selection mode is enabled.

Enlarged image display

The following shows the screen for displaying an enlarged image.

Window

Click image data in "Image list" when the image selection mode is disabled in the data set setting screen.

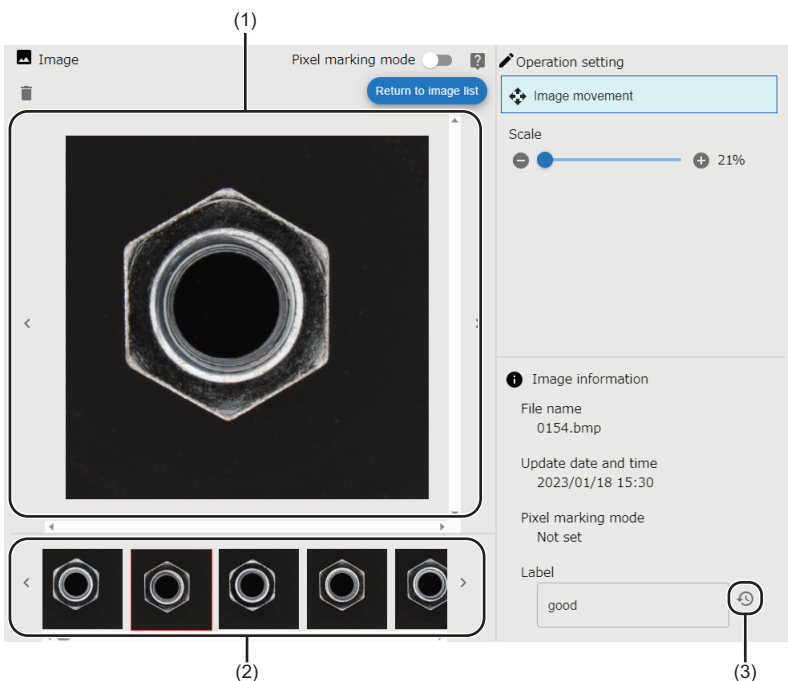

Displayed items

Item		Description
Image	Pixel marking mode	Turn ON or OFF the switch to change the display. <ul style="list-style-type: none"> • ON: Pixel marking mode (☞ Page 71 Pixel marking settings) • OFF: Enlarged image display (this screen)
	(Delete)	Click this to delete image data displayed in the image (1).
	[Return to image list] button	Click this to return to the image list. ☞ Page 68 Data Set Setting Screen
	(1) Image	Image data is displayed enlarged.
	(2) Thumbnail list	Image data to be displayed in the image (1) can be selected. Image data displayed in the list is as follows: <ul style="list-style-type: none"> • When switching to the enlarged image display from the image list, all image data in the image list is displayed. • When switching to the enlarged image display from the pixel marking setting display, all image data in the thumbnail list of the pixel marking setting display is displayed.
Operation setting	Image movement	Select this to move image data by dragging the data.
	Scale	Image data is enlarged or reduced.
Image information		The information of image data is displayed. Select a label to be attached to image data from the label selection list indicated in (3). A new label can be added by entering a label name (1 to 255 characters) in the text box.

Pixel marking settings

The following shows the procedure for setting pixel marking for image data.
 Image data with pixel marking settings can be used for generating an AI model for defective point detection.

Window

Turn ON "Pixel marking mode" in the enlarged image display of the data set setting screen.

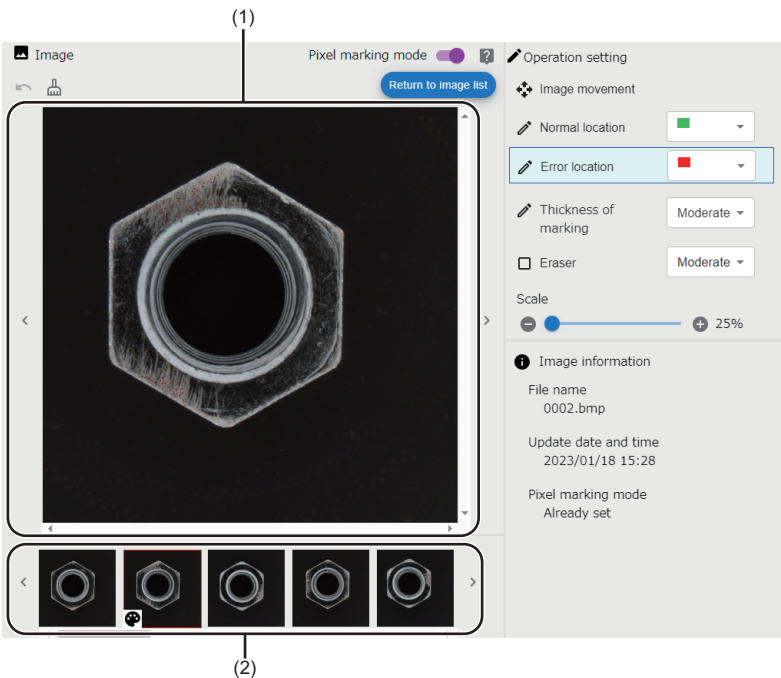

Displayed items

Item	Description
Image	Pixel marking mode Turn ON or OFF the switch to change the display. <ul style="list-style-type: none"> • ON: Pixel marking mode (this screen) • OFF: Enlarged image display (Page 70 Enlarged image display)
	[Return to image list] button Click this to return to the image list.*1 Page 68 Data Set Setting Screen
	(Return) Click this to return to the previous state of an operation when any of the following operations is performed: <ul style="list-style-type: none"> • Setting dots on normal locations • Setting dots on error locations • Eraser • Clear
	(Clear) Click this to clear all pixel marking settings configured for image data being displayed.
	(Save) Click this to save pixel marking settings.
	(1) Pixel marking setting area Pixel marking can be set for image data being displayed. Page 63 Setting pixel marking
	(2) Thumbnail list Image data to be displayed in the pixel marking setting area (1) can be selected.*1 Image data displayed in the list is as follows: <ul style="list-style-type: none"> • When switching to the pixel marking setting display from the image list, image data selected in the image list is displayed. • When switching to the pixel marking setting display from the enlarged image display, all image data in the thumbnail list of the enlarged image display is displayed.

Item		Description
Operation setting	Image movement	Select this to move image data by dragging the data.
	Normal location ^{*2}	Select this to set pixel marking, which represents a normal location, for image data. The color of marking can be changed from the list.
	Error location ^{*2}	Select this to set pixel marking, which represents an error location, for image data. The color of marking can be changed from the list.
	Thickness of marking	Select this to set the thickness of a dot for marking pixels.
	Eraser	Select this to remove pixel marking by dragging the eraser. The width of the eraser can be selected from the list.
	Scale	Image data is enlarged or reduced.
Image information		The information of image data is displayed.

*1 The pixel marking setting is saved when it is not saved.

*2 Cannot be set if 5,000 or more dots are set for the image data.

9 AI MODEL

This chapter explains AI models.

An AI model is generated by performing learning after creating and setting the model. The generated AI model can be used from a task.

The AI model can be created, set, and generated only with the development license.

9.1 AI Model

AI model is a machine learning model that can perform various kinds of automatic inspection for an inspection target. The model is generated by learning the image data of the target defective or non-defective products based on the settings of the following items:

Setting item	Description
Data set	Specify a data set in which the target image data is registered to use it as input data for generating an AI model.
Preprocessing	Set preprocessing to process input data before learning or inference is performed.
AI engine setting	Specify the labels of a data set for images to enable the AI engine to identify images for learning or validation and determine non-defective or defective products.

AI engine

In this product, a system that performs image data learning is called an AI engine.

There are two types of AI engines as shown below. An AI engine can be selected depending on the availability of obtaining image data to be learned, types of a work to be inspected, and types of a defect to be detected.

AI engine	When learning	When inspecting
Anomaly detection	To learn the image data of non-defective products	To determine 'error level' according to the difference between the learned non-defective product images and an inspection image*1
Defective point detection	To learn the error and normal locations of defective product image data for which pixel marking is set	To detect locations similar to the learned error locations from inspection images and determine a non-defective or defective product based on the degree of error in the images*1

*1 For details on the determination, refer to the following:
☞ Page 158 Processing block execution (executing)

Anomaly detection

Anomaly detection is an unsupervised AI engine that learns non-defective product image data. A non-defective or defective product is determined based on the difference (error level) between the learned non-defective product images and the input images for inference. It is also determined based on a threshold determined by a user.

An AI model can be generated easily by specifying only the labels of 'non-defective product' or 'defective product.' Detailed labels such as classification and defect types are not required to be specified.

Defective point detection

Defective point detection is a supervised AI engine that learns defective product image data for which pixel marking is set in advance. A non-defective or defective product is determined based on the degree of errors detected according to pixel marking and based on a threshold determined by a user.

The accuracy of an AI model changes depending on pixel marking even when the same image data is used for learning.

Point

- If a location near the boundary of an inspection target (the outline of a target work) is mistakenly determined as an error location, the judgment result may be improved by setting pixel marking (as a normal location) near the boundary.
- Defects on the edges of image data (areas equivalent to one percent of vertical and horizontal resolution from each side of the image data) are not detected in defective point detection. Therefore, it is recommended to capture images within the angle of view of a camera.
- When performing mask processing for preprocessing, the accuracy of an AI model may be improved by also setting pixels marking (as a normal location) on a location to be masked.

Precautions

- Pixel marking must be set for image data in advance because only image data for which pixel marking is set is used for defective point detection.
- A GPU is used for defective point detection and approximately 2.4 GB of GPU memory is occupied for each AI model during learning or inference (including when waiting for user verification). Therefore, the presence of a GPU and the available capacity of GPU memory must be checked.

Preprocessing

The following shows preprocessing which modifies image data before learning to improve inspection accuracy.

Preprocessing	Description
Trimming	To extract a specified trimming area
Mask	To fill and a specified mask area

Trimming

A specified trimming area is extracted.

Function	Effect
Removing the background outside of an inspection target (except for the area of an inspection target)	To prevent an erroneous determination caused by the background during learning and inspection
Deleting unnecessary areas	<ul style="list-style-type: none">• To improve processing performance• To reduce a file size

Mask

A specified mask area is filled.

Function	Effect
Removing the background inside of an inspection target (except for the area of an inspection target)	To prevent an erroneous determination caused by the background during learning and inspection

AI model status

The following shows the status of an AI model.

Status	Description
Editing	A status where an AI model is not generated or AI model settings are being edited. A newly created AI model will initially be in this status.
Generating	— A status where an AI model is being generated. A status is changed to this status when learning is started after an AI model is set.
	Learning A status where an AI model is learning during the process of generating the AI model. When learning is started, the learning of preprocessing and an AI engine is performed. It continues until there is no more learning data.
	Inferring A status where an AI model is making an inference during the process of generating the AI model. When learning is completed, the inference of preprocessing and an AI engine is performed. It continues until there is no more validation data.
Validating (Waiting for user validation)	A status where an AI model is generated and a threshold is determined.* ¹ Determine a threshold, which helps an AI model to determine inspection images, while checking the inference result* ² .
Generation failure	A status where an AI model fails to be generated.* ³ This status changes to 'Editing' after closing the AI model validation screen.
Complete	A status where an AI model is generated and a threshold is determined. An AI model can be used from a task.

*¹ AI model settings can be edited even when the status is 'Validating' so that the AI model can be improved repeatedly. However, an AI model is generated according to the AI model settings at the time of when learning is started. Therefore, learning must be performed again to apply the settings changed while the status is 'Validating.'

*² Inference can be performed and checked by using other validation data in the trial mode.

 Page 98 AI Model Validation Screen

*³ This is a temporary status after an AI model is generated.

The following table shows the availability of browsing each screen according to an AI model status.

○: Can be browsed, ×: Cannot be browsed

Screen	Editing	Generating	Generation failure	Validating	Complete
AI model setting	○ (Settings can be changed)	○ (Settings cannot be changed)	○ (Settings cannot be changed)	○ (Settings can be changed)	○ (Settings cannot be changed)
AI model validation	×	○	○	○	○

9.2 Creation Procedure for an AI Model

This section shows the procedure for creating an AI model.

1. Create a new AI model. (🔗 Page 76 Creating an AI model)
2. Set an AI model. (🔗 Page 77 Setting an AI model)
3. Check the accuracy of the AI model and determine a threshold. (🔗 Page 79 Validating an AI model)

Creating an AI model

The following shows the procedure for creating a new AI model.

Point

An AI model can also be created by duplicating a created AI model.

🔗 Page 83 AI Model Management Screen

Operating procedure

1. Click the [New] button in the AI model management screen. (🔗 Page 83 AI Model Management Screen)

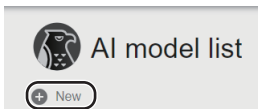

Point

An AI model can also be created by specifying a data set.

🔗 Page 65 Data Set Management Screen

2. Set the AI model information and click the [OK] button.

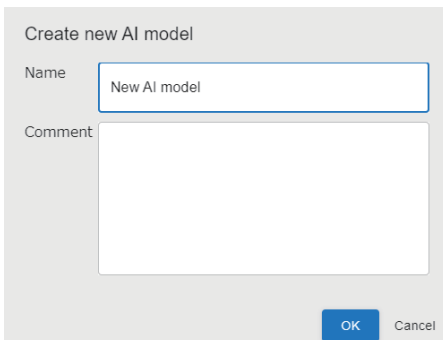
A screenshot of a dialog box titled 'Create new AI model'. It contains two input fields: 'Name' with the text 'New AI model' and 'Comment' which is empty. At the bottom right, there are two buttons: 'OK' and 'Cancel'.

Item	Description
Name	Set an AI model name (1 to 32 characters).
Comment	Set a comment (0 to 1024 characters).

Setting an AI model

The following shows the procedure for setting learning contents of an AI model and generating the AI model.

Operating procedure

1. Select an AI model to be set in the AI model management screen, and click the [Edit] button. (☞ Page 83 AI Model Management Screen)

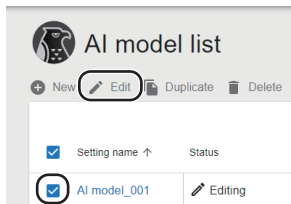

Point

When selecting an AI model whose status is 'Complete,' the AI model can be edited by the following methods:

- Duplicate and edit
- Overwrite edit

2. Select a data set to create an AI model, and click the [NEXT] button. (☞ Page 87 Data set selection screen)

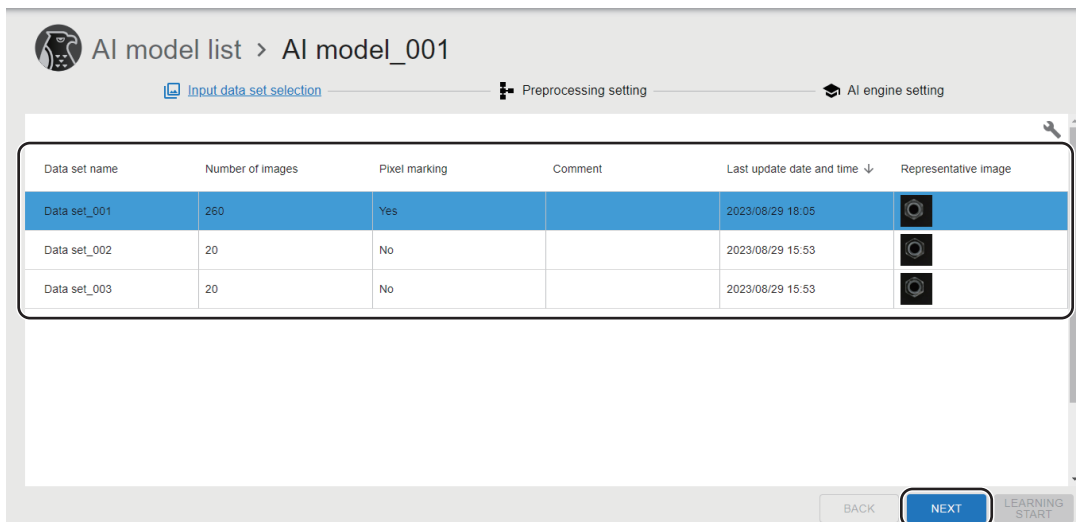

3. Set any preprocessing, and click the [NEXT] button. (👉 Page 89 Preprocessing selection screen)

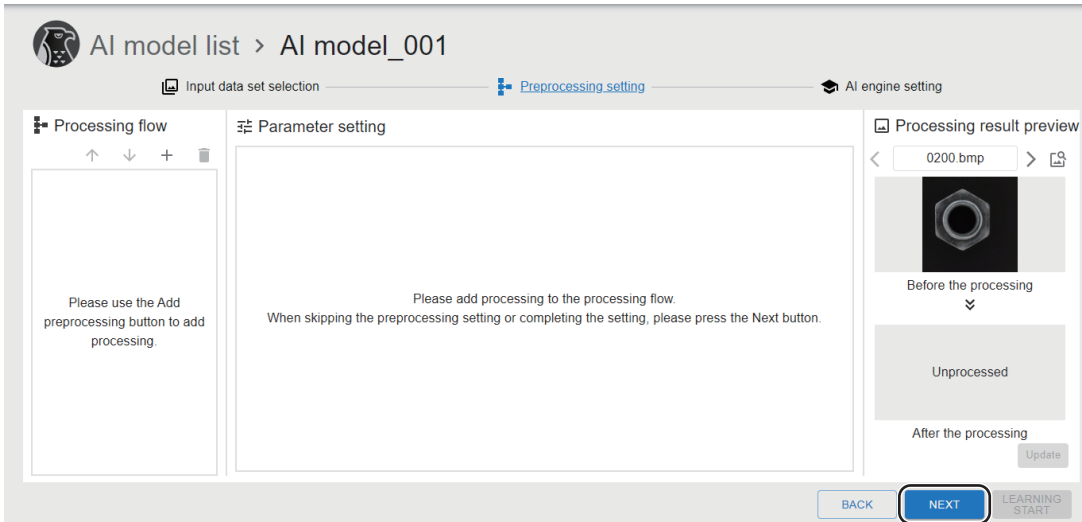

Point

Preprocessing can be skipped.

It is recommended to skip preprocessing when creating a new AI model and use it for improving the accuracy of an AI model.

4. Select an AI engine and specify labels for learning or validation. After that, click the [LEARNING START] button. (👉 Page 93 AI engine setting screen)

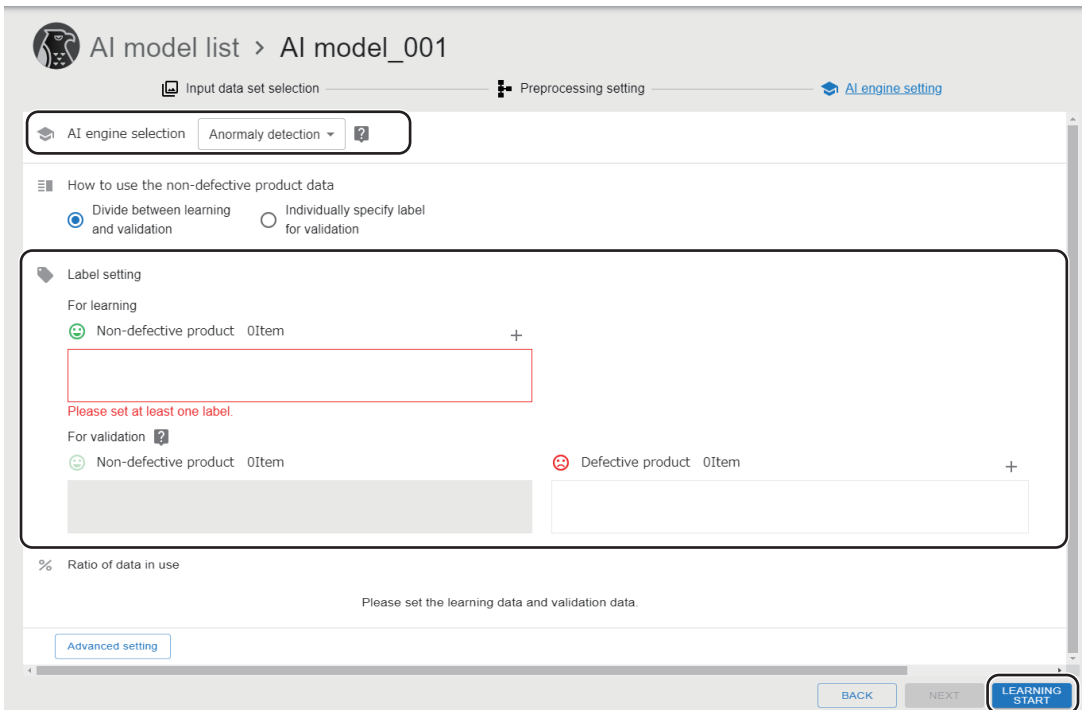

Point

It is recommended to specify labels for validation even if the process can be skipped so that the inference result can be checked at AI model validation.

Validating an AI model

The following shows the procedure for checking the accuracy of an AI model and determining a threshold.

Operating procedure

1. Select an AI model in the AI model management screen, and click the [AI model validation] button. ([Page 83 AI Model Management Screen](#))

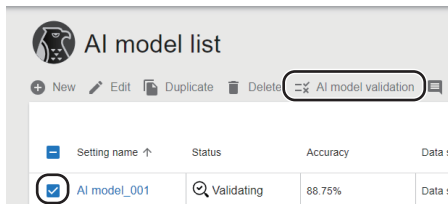

2. Check the inference result and determine a threshold that helps an AI model to determine inspection images. ([Page 98 AI Model Validation Screen](#))

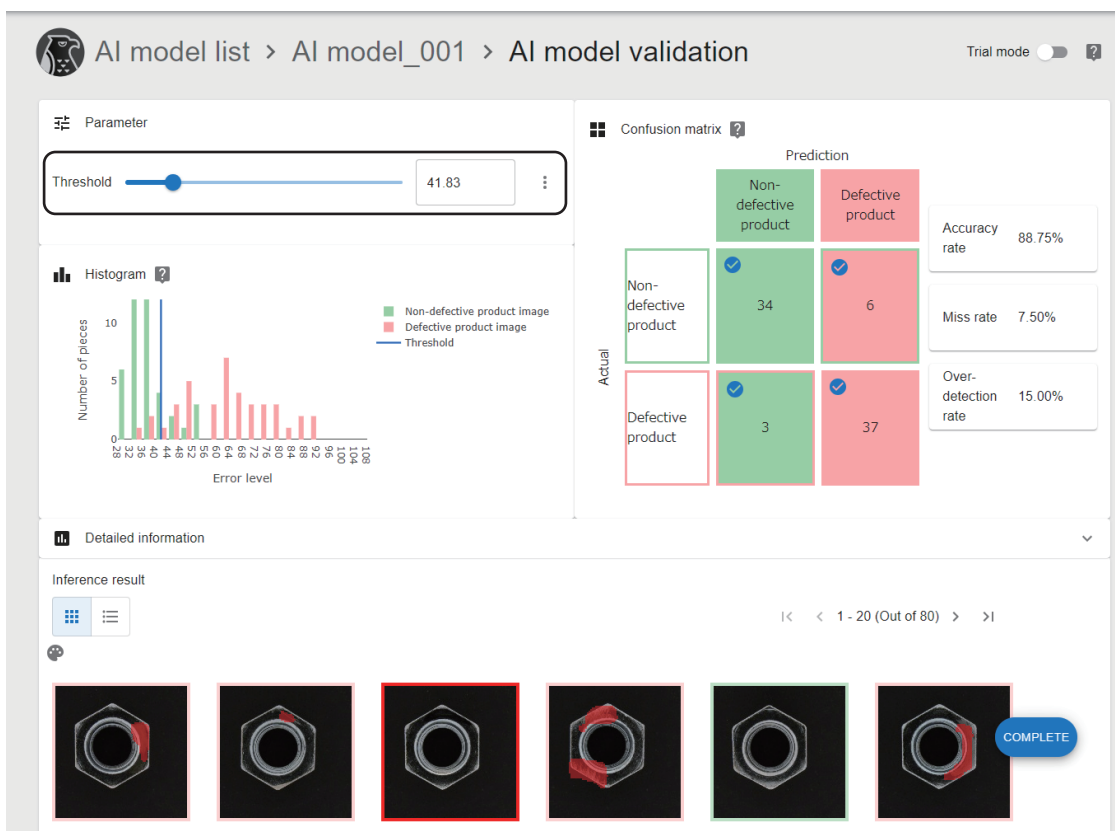

Point

- By turning ON the trial mode, the generated AI model can be tested using other validation data.
- If the accuracy of an AI model is low, improve the AI model by referring to the following: ([Page 166 Improvement of AI Models](#))

3. Click the [COMPLETE] button.

9.3 Deployment Procedure for an AI Model

This section shows the procedure for connecting to another personal computer and duplicating the generated AI model.

An AI model is deployed for the following purpose:



- Learning an AI model again in the learning machine and duplicating the model to the inspection machine to update an AI model used in the task of the inspection machine

Precautions

- An AI model to be deployed must be in 'Complete' status.
- To deploy an AI model, the operation status of this product installed on a personal computer of a deployment destination must be in the running status.

(☞ Page 33 Startup tool)

Operating procedure

1. Select an AI model to be deployed in the AI model management screen, click  (Other options), and then select [Deploy]. ( Page 83 AI Model Management Screen)

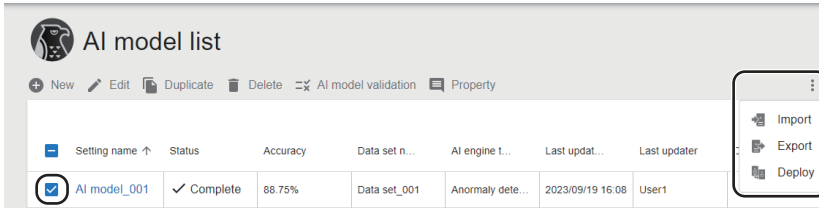

2. Enter the information of a deployment destination in the connection destination setting screen, and click [Connect] button.

Connection destination setting
Please input the information on the deployment destination.

IP address 
Please input a value.

Port number
Please input a value.

User ID

Input password
Please input a value.

Item	Description
	Click this to display the information of up to 10 connection destination settings ^{*1} which have been used in the past. By selecting a setting from the history, information other than the password is applied.
IP address	Enter the IP address of a connection destination.
Port number	Enter the port number of a connection destination.
User ID	Enter a user ID to be signed in.
Input password	Enter the password of a user ID to be signed in.

*1 If the number of pieces of past information exceeds 10, the information will be deleted in chronological order.

3. Select a project of a deployment destination in the deployment setting screen, and click the [Deploy] button.

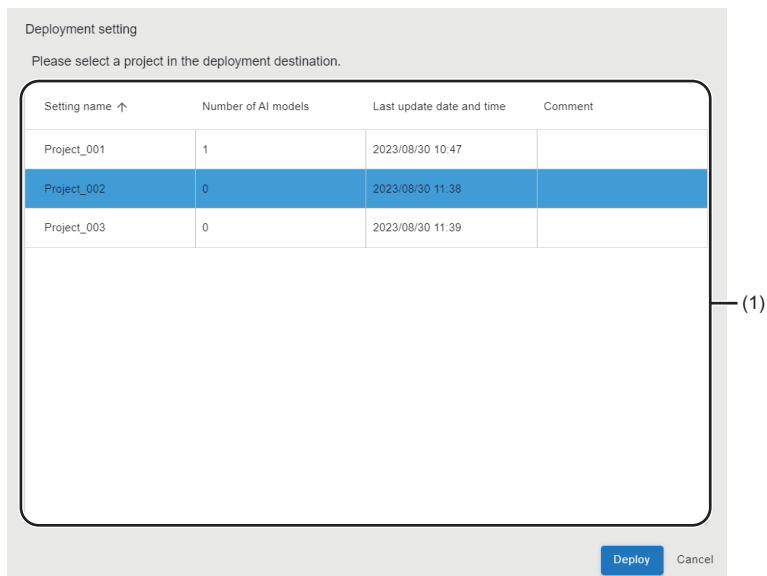

Item	Description	
(1) Project list*1	Setting name	A project name is displayed.
	Number of AI models	The number of AI models set for a project is displayed.
	Last update date and time	The last date and time when a project was updated is displayed.
	Comment	A comment set for a project is displayed.

*1 The following project cannot be selected: A project that a user who is signed in from the connection destination setting screen does not have access authority or does not have the full control authority for its AI models.

Precautions



- If an AI model name is duplicated with the one in the deployment destination, a serial number is attached to the name in the same way as when duplicating an AI model. (📖 Page 84 Behavior when duplicating an AI model)
- Even if the deployment fails when multiple AI models are selected in the AI model management screen, the AI models will be deployed except the failed ones.

9.4 AI Model Management Screen

This section shows the screen for creating and managing AI models.







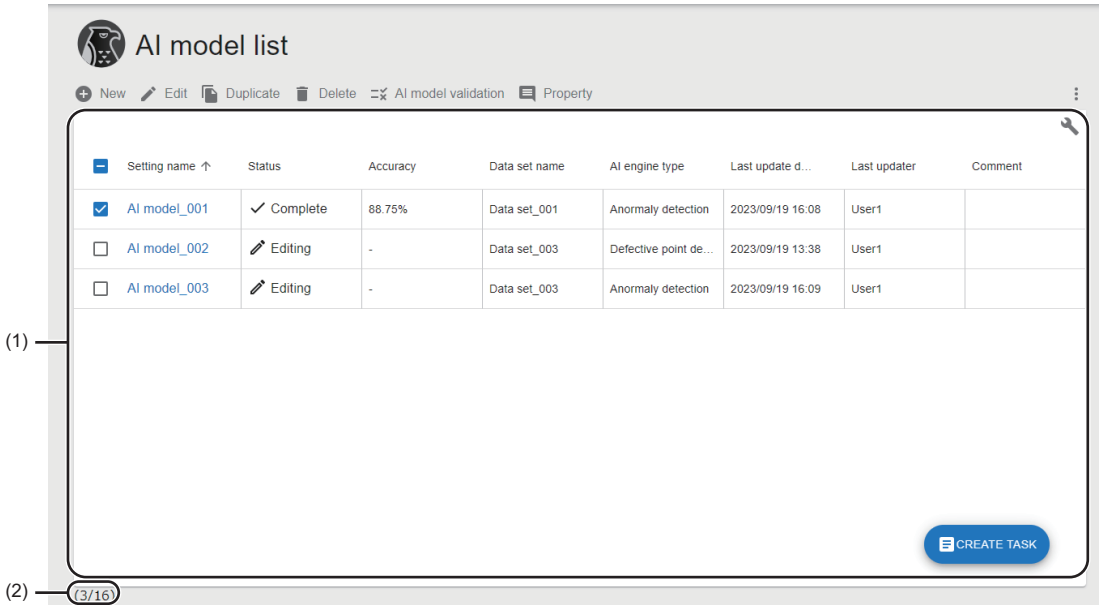

AI model information including the progress of generating an AI model can also be checked.



Window

Click  (AI model) on the side bar. ( Page 40 Side bar)



Displayed items

Item	Description	
New	Click this to create a new AI model.  Page 76 Creating an AI model	
Edit	Click this to edit a selected AI model setting.  Page 86 AI Model Setting Screen	
Duplicate	Click this to duplicate a selected AI model. For the contents of the duplicated AI model, refer to the following:  Page 84 Behavior when duplicating an AI model If the duplication fails when multiple AI models are selected, the duplication of an AI model which failed to be duplicated and subsequent AI models will be canceled. (If the number of AI models after duplication exceeds the maximum number, the duplication of all AI models will be canceled.)	
Delete	Click this to delete a selected AI model. Even if the deletion fails when multiple AI models are selected, the AI models will be deleted except the failed ones.	
AI model validation ^{*1}	Click this to validate a selected AI model.  Page 79 Validating an AI model	
Property	Click this to check or change the properties of a selected AI model.  Page 85 AI model properties	
 (Other options)	Import	Click this to import an AI model created in another personal computer. Settings that are already created in a project will not be deleted even if the import fails during the process.  Page 53 Import
	Export	Click this to export an AI model so that it can be utilized in other personal computers.  Page 52 Export
	Deploy	Click this to connect to another personal computer and duplicate a created AI model.  Page 80 Deployment Procedure for an AI Model

Item	Description
(1) AI model list	Setting name The name of an AI model is displayed. The AI model setting screen appears by clicking an AI model name.* ²  Page 86 AI Model Setting Screen
	Status The status of an AI model is displayed.  Page 75 AI model status
	Accuracy The learning performance (accuracy rate) of an AI model is displayed.
	Miss rate* ³ The learning performance (miss rate) of an AI model is displayed.
	Over-detection rate* ³ The learning performance (over-detection rate) of an AI model is displayed.
	Threshold* ³ The threshold of an AI model is displayed.
	Data set name A data set name set for an AI model is displayed.
	AI engine type The type of an AI engine is displayed.
	Size* ³ The file size* ⁴ of an AI model setting is displayed.
	Data at AI model generation* ³ The representative image of a data set that is set for an AI model is displayed.
	Creation date and time* ³ The date and time when an AI model was created is displayed.
	Creator* ³ The ID of a user who created an AI model is displayed.
	Last update date and time The last update date and time* ⁵ of an AI model is displayed.
	Last updater The ID of a user who last updated an AI model is displayed.
	Comment A set comment is displayed.
[CREATE TASK] button* ⁶	Click this to create a task using a selected AI model.
(2) Number of settings	The number of created AI models and the maximum number of AI models that can be created are displayed.

*1 Can be selected when the selected AI model is in any of the following statuses: 'Generating,' 'Validating,' 'Generation failure,' or 'Complete.'

*2 When the selected AI model is in the 'Complete' status, the AI model setting screen opens in a state where the AI model cannot be edited.

*3 Displayed by expanding the header.
 Page 41 Expanding the header

*4 The file size is the same as that of an AI model for deployment and that of an AI model setting in a project file for export.

*5 It is not changed even when changing the properties.

*6 Displayed when the selected AI model is in the 'Complete' status.

Behavior when duplicating an AI model

Contents of a duplicated AI model are changed as follows:

Item	Description
Setting name	A three-digit number with zero padding is added to the end of the setting name of the duplicate source. The initial value '(001)' is added to the end of the setting name and it is incremented to prevent the name from being duplicated with other AI models. If the setting name exceeds the maximum number of characters (32 characters) after duplication, characters after the first 27 characters are deleted from the name and the number is added.
Status	It is changed to 'Editing' when the status of the duplicate source is other than 'Complete.'
Creation date and time	It is changed to the date and time when the AI model is duplicated.
Others	They are not changed from the duplicate source. However, when the status of the duplicate source is other than 'Complete,' the status of the duplicate destination is changed to 'Editing.' Therefore, the following items will be displayed with '-': <ul style="list-style-type: none"> • Accuracy • Miss rate • Over-detection rate • Threshold

AI model properties

The following operations can be performed: changing the name and comments of an AI model and checking the property information.

Window

Select an AI model in the AI model management screen, and click the [Property] button. (☞ Page 83 AI Model Management Screen)

Property of AI model_001

Name: AI model_001

Comment:

Creation date and time : 2023/08/29 18:09
 Update date and time : 2023/08/29 19:44
 Size (MB) : 73.5(MB)
 Status : Complete
 Data set name : Data set_001
 Accuracy : 92.5
 Model type : Anomaly detection
 Last updater : User1
 Creator : User1

(1)

OK Cancel

Displayed items

Item	Description
Name	Set an AI model name (1 to 32 characters).
Comment	Set a comment (0 to 1024 characters).
(1) Property information	The property information of an AI model is displayed.

Point

The last update date and time of an AI model is not changed even when changing a name and comment.

9.5 AI Model Setting Screen

This section shows the screen for setting learning contents of an AI model and generating the AI model.

Window

Select an AI model to be set in the AI model management screen, and click the [Edit] button. (☞ Page 83 AI Model Management Screen)

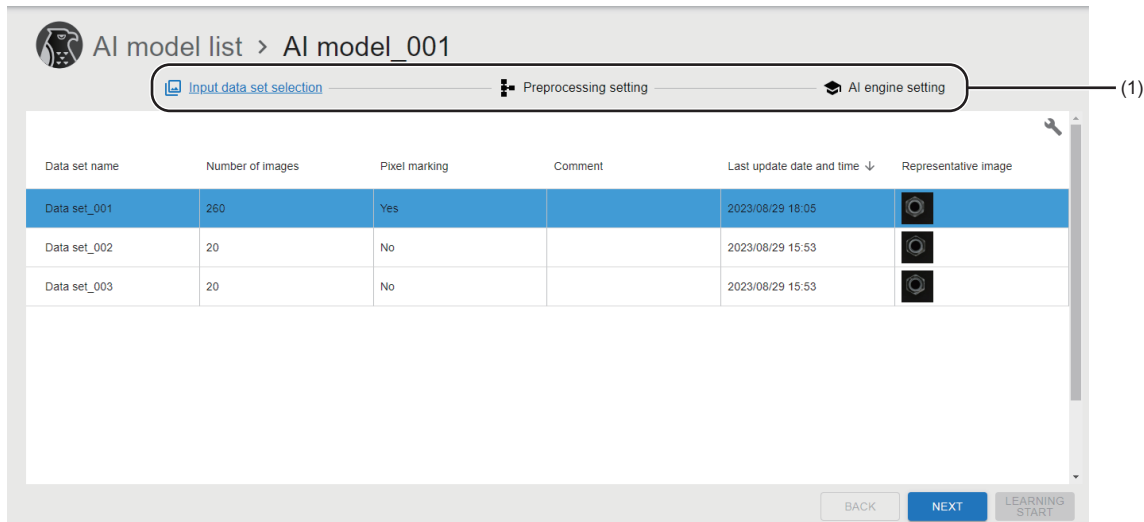

Displayed items

Item	Description
(1) Step	Steps for setting an AI model are displayed. ☞ Page 87 Data set selection screen ☞ Page 89 Preprocessing selection screen ☞ Page 93 AI engine setting screen
[Edit] button* ¹	Click this to edit an AI model setting.
[LEARNING START] button* ²	Click this to start AI model learning.
[LEARNING RESULT] button* ³	Click this to check the learning result of an AI model. ☞ Page 98 AI Model Validation Screen

*1 Displayed when the status of the AI model is 'Complete.'

*2 Can be clicked when setting at the "AI engine setting" step.

Displayed when the status of the AI model is other than 'Complete.'

*3 Displayed when setting at the "AI engine setting" step and when the AI model status is 'Complete.'

Data set selection screen

The following shows the screen for selecting a data set to be used for the input data of an AI model.

Window

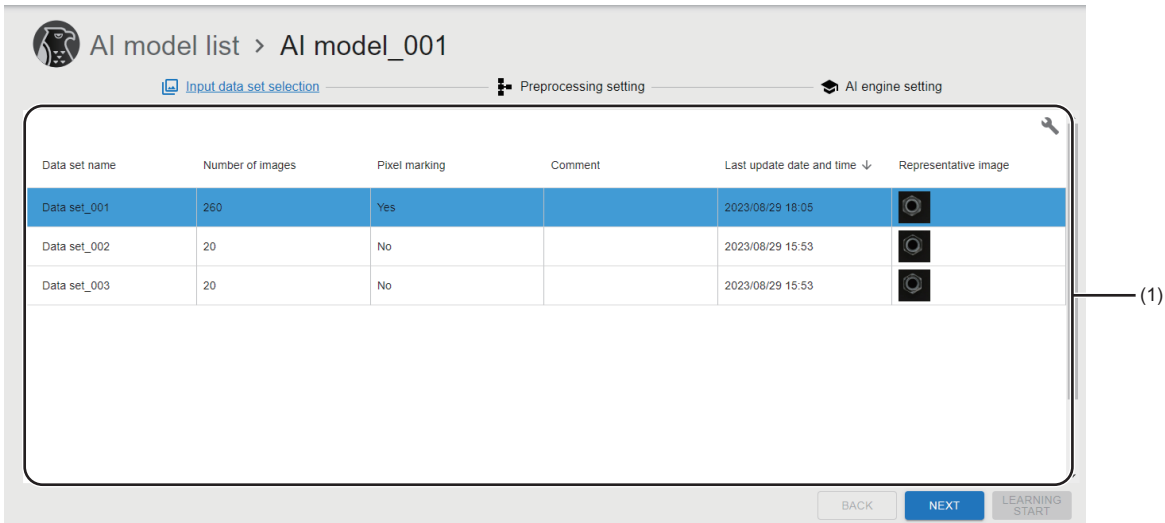

Displayed items

Item	Description	
(1) Data set list	Data set name	A data set name is displayed.
	Number of images	The number of images in a data set is displayed.
	Pixel marking	The presence of pixel marking is displayed.
	Comment	A data set comment is displayed.
	Last update date and time	The last date and time when a data set was updated is displayed.
	Representative image	Among images registered in a data set, the image data that has the latest update date and time is displayed. Image data registered in a data set can be checked by clicking the image data. Page 88 Check data set image screen

Check data set image screen

The following shows the screen for checking image data registered in a data set.

Window

Click a representative image in the data set selection screen. (☞ Page 87 Data set selection screen)

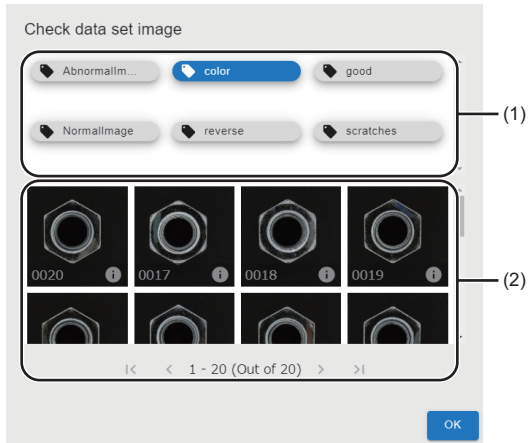

Displayed items

Item	Description
(1) Label list	Labels registered in a data set are displayed. By selecting a label, the corresponding image data is displayed in the image list (2).
(2) Image list	Image data of a label selected in the label list (1) is displayed.

Preprocessing selection screen

The following shows the screen for configuring settings for processing input data before the learning or inference of an AI model.

Point

Preprocessing can be skipped.

It is recommended to skip preprocessing when creating a new AI model and use it for improving the accuracy of an AI model.

Precautions

When setting multiple preprocessing steps and changing the processing order, the effect of preprocessing may be changed.

Window

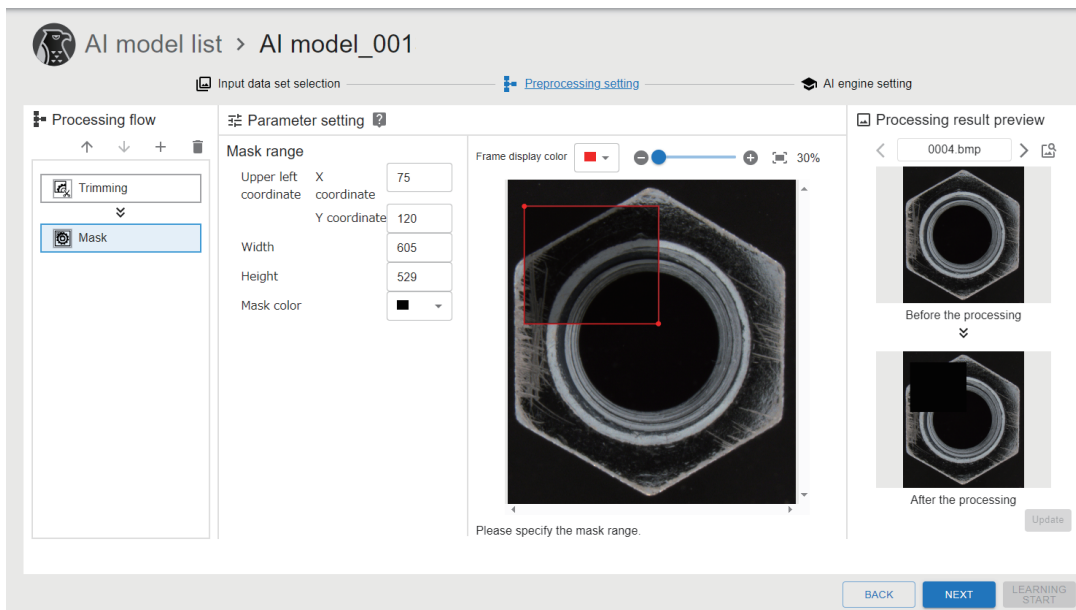

Displayed items

Item	Description	
Processing flow	—	A series of preprocessing flow can be set. ❗ is displayed for preprocessing that failed to execute.
	↑/↓	Click either of these to change the order of the selected preprocessing.
	+ (Add preprocessing)	Click this to add preprocessing to a process flow.
	🗑️ (Delete preprocessing)	Click this to delete preprocessing from a process flow.
Parameter setting	Set parameters of preprocessing being selected in a process flow. 📖 Page 90 Trimming 📖 Page 91 Mask	
Processing result preview	—	The processing result of preprocessing being selected in a process flow can be checked. When selecting the second or any subsequent preprocessing, the processing result of the selected preprocessing and of all preprocessing before the selected one is displayed.
	🖼️ (Image selection)	Click this to select image data to be displayed in the processing result preview. 📖 Page 92 Selecting images
	[Update] button	Click this to display the processed image data.

Trimming

The following shows the screen for setting the behavior of the trimming processing.

Window

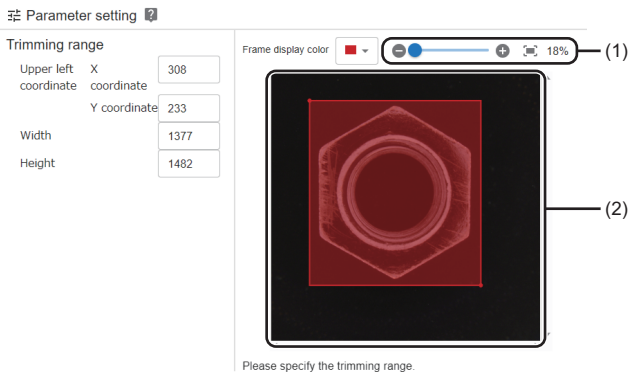

Displayed items

Item		Description
Trimming range	Upper left coordinate	Set the upper left coordinates (X coordinate and Y coordinate) of a trimming range.
	Width	Set the width of a trimming range.
	Height	Set the height of a trimming range.
Frame display color		Select the display color of a trimming range frame.
(1) Image scaling		Image data is enlarged or reduced. By clicking  (Fit display), an image size can be adjusted to fit within the frame setting area.
(2) Frame setting area		Set a trimming range frame on the displayed image data using a mouse.

Mask

The following shows the screen for setting the behavior of the mask processing.

Window

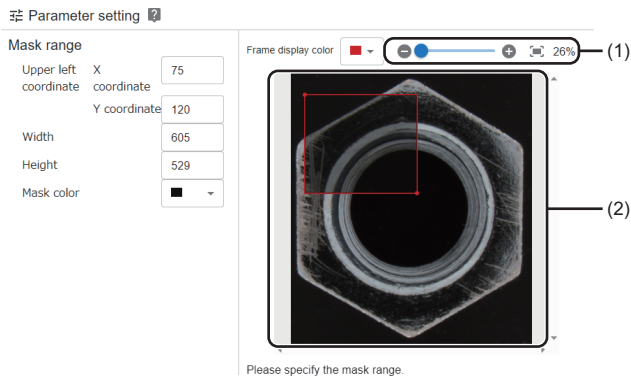

Displayed items

Item		Description
Mask range	Upper left coordinate	Set the upper left coordinates (X coordinate and Y coordinate) of a mask range.
	Width	Set the width of a mask range.
	Height	Set the height of a mask range.
	Mask color	Select a mask color.
Frame display color		Select the display color of a mask range frame.
(1) Image scaling		Image data is enlarged or reduced. By clicking  (Fit display), an image size can be adjusted to fit within the frame setting area.
(2) Frame setting area		Set a mask range frame on the displayed image data using a mouse.

Selecting images

The following shows the screen for selecting image data to be displayed in the processing result preview.

Window

Click  (Image selection) in the preprocessing selection screen. ([Page 89 Preprocessing selection screen](#))

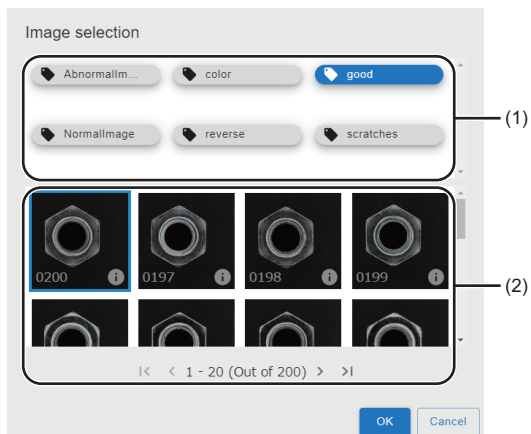

Displayed items

Item	Description
(1) Label list	Labels registered in a data set are displayed. By selecting a label, the corresponding image data is displayed in the image list (2).
(2) Image list	Select image data to be displayed in the processing result preview from the image data of a label selected in the label list (1).

AI engine setting screen

The following shows the screen for selecting an AI engine to generate an AI model and specifying image data for learning and inference with labels.

Point 

It is recommended to specify labels for validation even if the process can be skipped so that the inference result can be checked at AI model validation.

Anomaly detection

The following shows the screen for specifying labels for anomaly detection.

Window

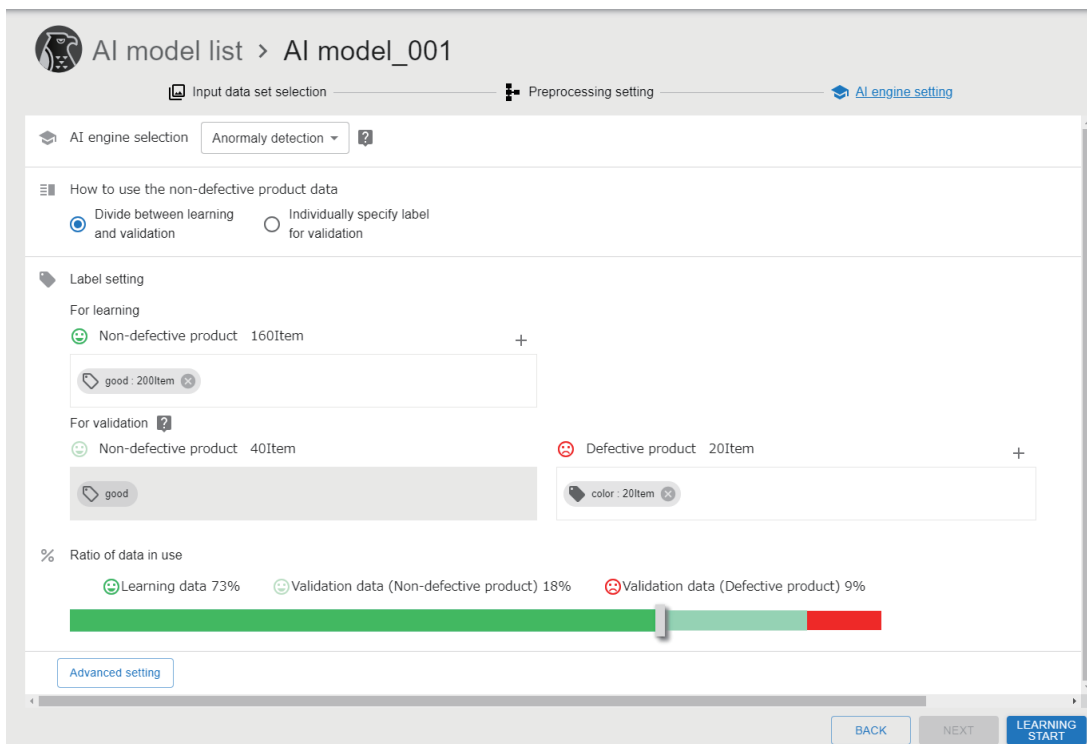

Displayed items

Item	Description	
AI engine selection	Select "Anomaly detection."	
How to use the non-defective product data	Divide between learning and validation	Select this to use the image data of the specified label by dividing the data between learning and inference categories. It can be set with less effort because image data is sorted automatically. However, which image data to use for learning or validation cannot be specified individually.
	Individually specify label for validation	Select this to specify labels of non-defective product data to be used for validation individually. It can be selected when specifying image data to be used for learning or validation clearly.
Label setting ^{*1}	For learning	Non-defective product Select labels of non-defective product data to be used for learning by clicking + (Add label). 📖 Page 96 Selecting labels
	For validation	Non-defective product When selecting "Individually specify label for validation" for "How to use the non-defective product data," click + (Add label) and select a label for non-defective product data to be used for validation.
		Defective product Select labels of defective product data to be used for validation by clicking + (Add label). 📖 Page 96 Selecting labels
Ratio of data in use	A ratio between learning data and validation data is displayed. When selecting "Divide between learning and validation" for "How to use the non-defective product data," the ratio for using learning data and validation data is required to be set with the slider.	
[Advanced setting] button	Click this to configure the advanced setting. 📖 Page 97 Configuring the advanced setting	

*1 The icon of a label to be displayed differs depending on the pixel marking setting status.

📄: Without pixel marking

📄: With pixel marking

Defective point detection

The following shows the screen for specifying labels for defective point detection.

Window

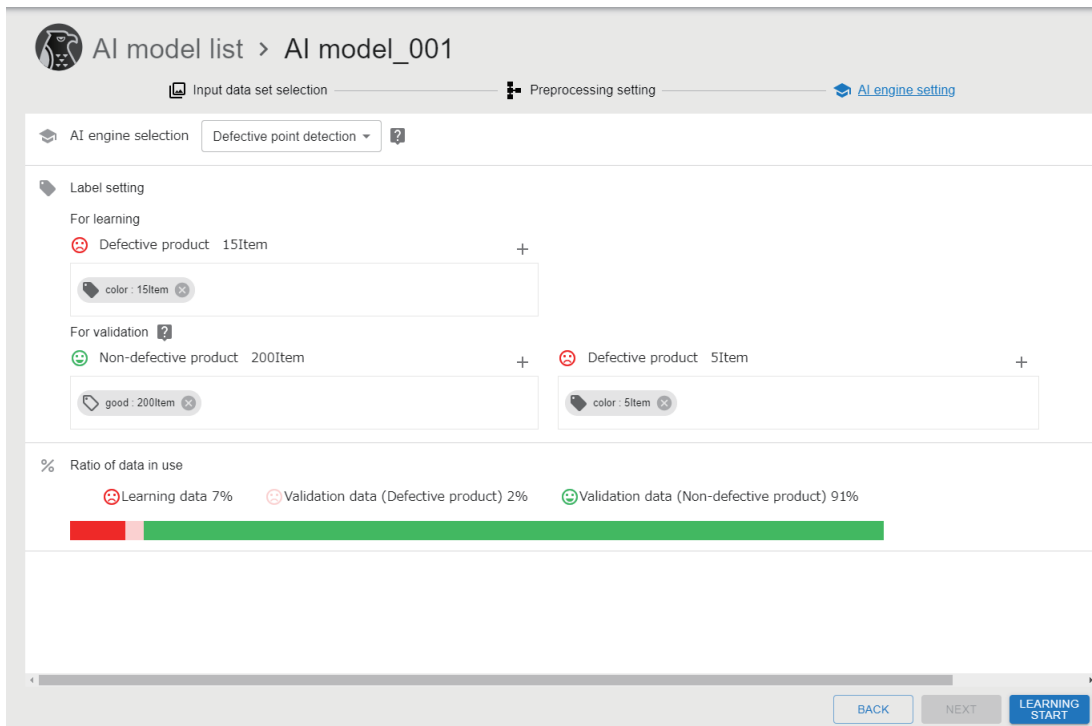

Displayed items

Item			Description
AI engine selection			Select "Defective point detection."
Label setting ^{*1}	For learning	Defective product	Select labels of defective product data to be used for learning by clicking + (Add label). 👉 Page 96 Selecting labels
	For validation	Non-defective product	Select labels of non-defective product data to be used for validation by clicking + (Add label). 👉 Page 96 Selecting labels
		Defective product	Same labels as those used for learning are displayed ^{*2} . To add validation data, select labels of defective product data by clicking + (Add label). 👉 Page 96 Selecting labels
Ratio of data in use			A ratio between learning data and validation data is displayed.

*1 The icon of a label to be displayed differs depending on the pixel marking setting status.

👉: Without pixel marking

👉: With pixel marking

*2 The number of pieces of image data without pixel marking settings is displayed.

Selecting labels

The following shows the screen for selecting the labels of data to be used for learning and validation.

When selecting defective product data for learning to use for defective point detection, only labels which include pixel marking settings are displayed.

Window

Click **+** (Add label) in the AI engine setting screen. (☞ Page 93 AI engine setting screen)

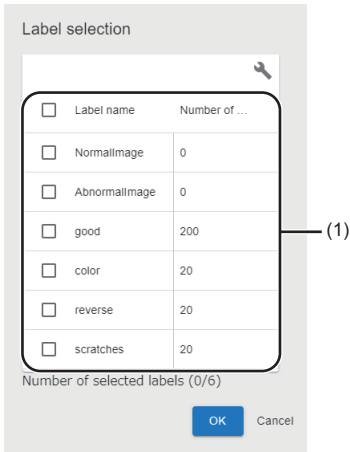

Displayed items

Item		Description
(1) Label list	Label name	Label names registered to a data set are displayed.
	Number of pieces	The number of pieces of image data corresponded to a label is displayed. <ul style="list-style-type: none"> Defective product data (for learning) for defective point detection: The number of pieces of image data with pixel marking settings. Other than above: The number of pieces of image data without pixel marking settings.

Configuring the advanced setting

The following shows the screen for setting the items below to improve the accuracy of an AI model for anomaly detection.

Item	Description
Data extension	When only a little learning data is available, learning data can be increased by converting the image data of a selected label.*1 The number of images to be newly generated and a method for converting images can be set. The image data conversion processing is performed using a random value within the set value range.
Model parameter	The high resolution mode can be enabled. When the range of a defective area to be detected during inspection is small, the accuracy of an AI model may be improved by enabling the high resolution mode. However, note that the memory usage and computational effort are increased by enabling the high resolution mode.

*1 Generated image data is only temporary and is deleted at the timing when learning for the AI model is completed.

Window

Click the [Advanced setting] button in the AI engine setting screen (at anomaly detection). ( Page 94 Anomaly detection)



Displayed items

Item	Description	
Data extension	Rotation	Turn this ON to rotate image data. Set the range of rotation on the left or right side (-180 to 180). The text box on the left side indicates a counter-clockwise rotation and the text box on the right side indicates a clockwise rotation.
	Horizontal shift	Turn this ON to move image data horizontally. Set the range of horizontal movement (-25 to 25). The text box on the left side indicates a shift to the left and the text box on the right side indicates a shift to the right.
	Vertical shift	Turn this ON to move image data vertically. Set the range of vertical movement (-25 to 25). The text box on the left side indicates a shift downward and the text box on the right side indicates a shift upward.
	Brightness	Turn this ON to change the brightness of image data. Set the range of contrast (-25 to 25). The text box on the left side indicates darkness and the text box on the right side indicates brightness.
	Number of extended pieces	Set the number of pieces of image data to be increased (1 to 10,000).
Model parameter	High resolution mode	Turn this ON to enable the high resolution mode.

9.6 AI Model Validation Screen

This section shows the screen for checking the learning status of an AI model, validating the generated AI model, and determining the threshold of the model.

Point

- is displayed on the right side of the screen title during learning or inference. By clicking , the progress status of the learning or inference can be checked.
- By turning ON the trial mode, the generated AI model can be tested using other validation data.





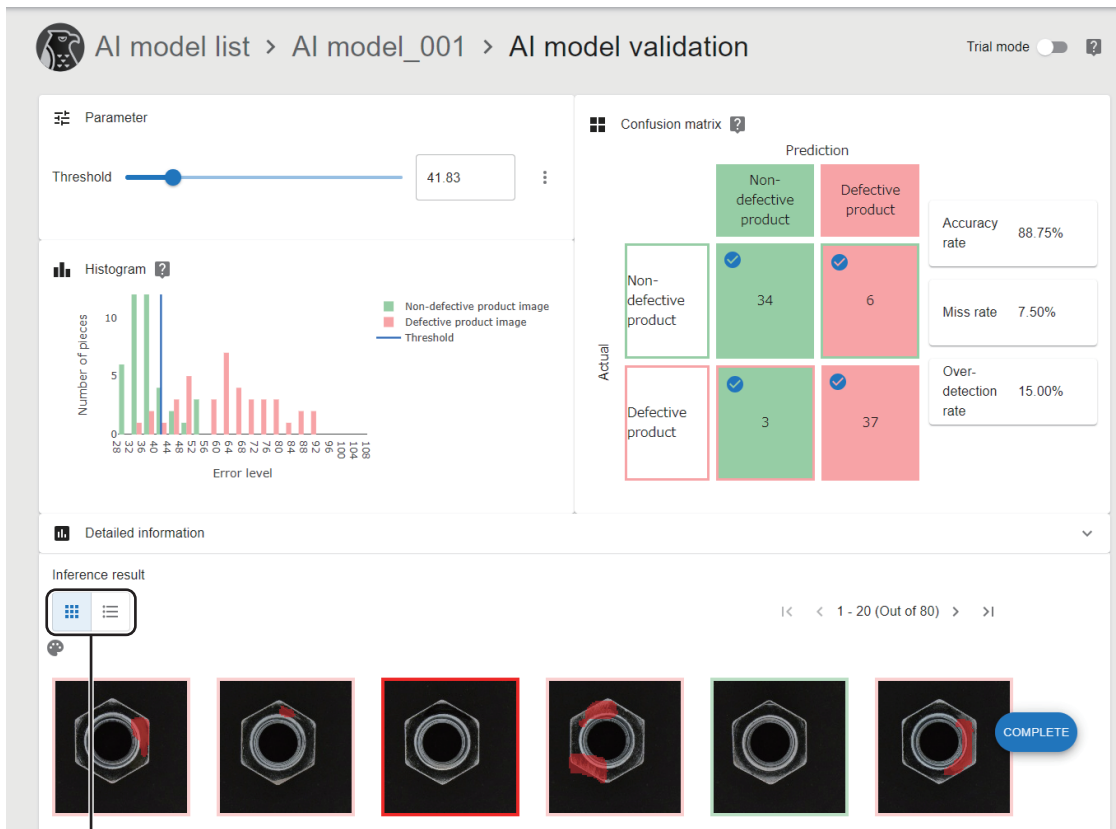

Window

Select an AI model in the AI model management screen, and click the [AI model validation] button. (Page 83 AI Model Management Screen)



Displayed items

Item	Description
Trial mode	Turn this ON to test an AI model using other validation data. When the mode is turned OFF, the result of validation performed using validation data, which is set at learning, is displayed.
Validation data selection	Add to non-defective product Inference is performed by dragging and dropping non-defective product data to be used for a trial. The data can be added by clicking the [Select image file] button.
	Add to defective product Inference is performed by dragging and dropping defective product data to be used for a trial. The data can be added by clicking the [Select image file] button.
	[Validation data clear] button Click this to clear validation data added in the trial mode.
Parameter	Judgment method Select a determination method for defective point detection.
	Threshold ^{*1} Set a threshold. It can also be set with the slider. By clicking , a threshold can be adjusted to set the maximum accuracy rate or minimum miss rate.

Item		Description
Histogram		<p>A histogram of validation data is displayed.</p> <p>For anomaly detection, adjust a threshold to determine non-defective products using the slider of "Threshold." The value can be adjusted while checking the positional relationship between the error level distribution and the threshold on a graph.</p> <p>For defective point detection, adjust a threshold to determine non-defective products with the slider of "Threshold." The value can be adjusted while checking the positional relationship between the error level distribution and the threshold on a graph.</p>
Confusion matrix		A matrix of actual and predicted non-defective and defective products can be displayed to check the accuracy rate, miss rate, and over-detection rate for the validation data of the generated AI model. The inference results can be filtered by selecting  in a cell.
Detailed information		<p>The detailed information of the following items are displayed by clicking .</p> <ul style="list-style-type: none"> • Processing time • AI model information • Supplemental information
Inference result	(1) Display switch button	Click either of these to switch the inference result display to a heat map or result list.
	Heat map	Heat map images of validation data are displayed in a list. The frame color depends on a color corresponding to the position of "Confusion matrix." ( Page 99 A frame of a heat map image) Detailed information can be checked by clicking an image. ( Page 100 Details) A color can be adjusted by clicking  (Color adjustment). ( Page 101 Color adjustment)
		Result list
	Judgment result	Whether the actual and predicted data match is displayed.
	File name	A file name of target image data is displayed. Detailed information can be checked by clicking the name.  Page 100 Details
	Actual	Actual non-defective and defective products are displayed.
	Prediction	Predicted non-defective and defective products are displayed.
	Error level	The error level of anomaly detection is displayed.
	Error location (total)	The sum of error locations in an image detected during defective point detection is displayed.
	Error location (maximum)	The largest error location area of an image detected during defective point detection is displayed.
Label name ^{*2}	A label name of target image data is displayed.	
[Complete] button		Click this to determine the set threshold and change the status of an AI model to 'Complete.'
[EDIT AGAIN] button		Click this to change the status of an AI model to 'Validating' and enable the threshold to be changed.

*1 A confusion matrix, histogram, and inference result are also changed by changing a threshold.

*2 Displayed by expanding the header.

 Page 41 Expanding the header

A frame of a heat map image

A frame color depends on a color corresponding to the position of "Confusion matrix."

Actual	Prediction	
	Non-defective product	Defective product
Non-defective product		
Defective product		

Details

The following shows the screen for checking the detailed information of a heat map image.

Window

Click a heat map image in the AI model validation screen. (☞ Page 98 AI Model Validation Screen)

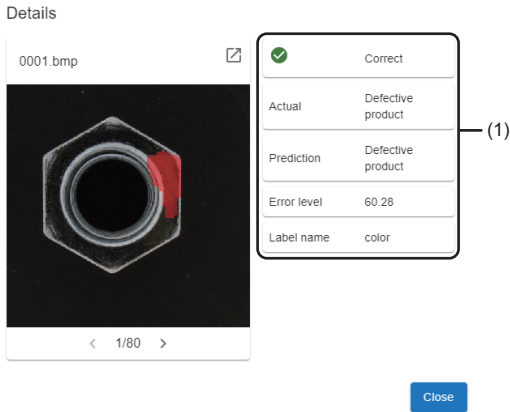

Displayed items

Item	Description
	Click this to display the heat map image in another tab.
(1) Inference result	The inference result of validation data is displayed.

Precautions

If the error location of image data is small, the error location actually detected may not be displayed correctly on the heat map image of the detail screen and of the AI model validation screen.



To check the actual error location, display the heat map image in another tab from the detail screen.

Color adjustment

The following shows the screen for changing a color to be used for a heat map.

A highlighted area can be displayed clearly by changing the color if the color of the original image data is similar to the color of a heat map image.

Window

Click  (Color adjustment) in the AI model validation screen. ( Page 98 AI Model Validation Screen)

Color adjustment

Color

Transmittance 50 %

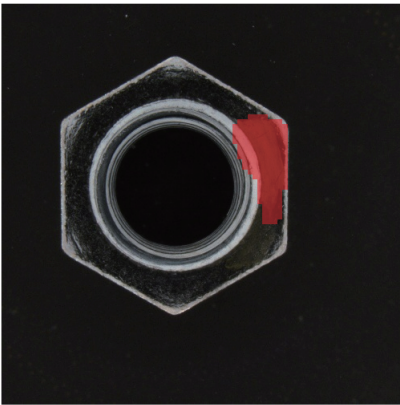

OK Cancel

Displayed items

Item	Description
Color	Select a heat map color.
Transmittance	Set the transmittance of a heat map (0 to 100). It can also be set with the slider.

10 TASK

This chapter explains tasks.

Tasks can be created and executed regardless of license types. However, AI models can be generated only by using the development license. To use a task, which performs inspection with an AI model, by using the run-time license, an AI model to be used must be prepared in advance.

10.1 Task

A task is a function that performs the following:

- Saving image data captured by a camera by linking with the camera and a programmable controller
- Performing inspection on image data with an AI model
- Providing a feedback on inspection results to a programmable controller

Point

When not controlling a camera from a task (such as using an existing camera and controlling a camera in detail), saved image data can be used by linking with a file server.

Executing a task

Processing that is executed by a task is called task processing. It is executed repeatedly once a task is executed.

Task processing consists of processing blocks which perform processing for each function and a task flow which represents a processing flow.

A task flow can be set on the canvas in a flow format (a format that connects a contact (2) between the placed processing blocks (1) using a connector (3)). (☞ Page 122 Task Flow Setting Screen)

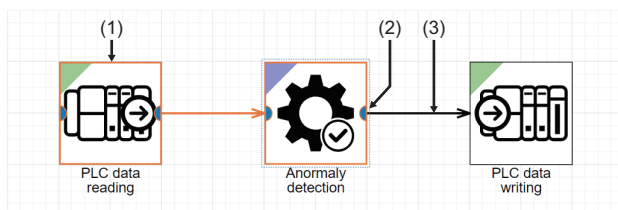

Inspection result history

At the end of task processing, the information of each unit of task processing (such as the start time of task processing, image data captured by a camera, device values of a programmable controller, and the inspection result of an AI model) can be saved as an inspection result history.

The saved inspection result history can be used for traceability.

Additionally, the image data of an inspection result history can be downloaded and it can be utilized for improving an AI model and checking for degradation.

Task status

The following shows the status of a task.

Status	Description
Editing	A status where the task is being edited. The task cannot be started because the task setting is not completed. The newly created task will be in this status until the setting is completed. In addition, a status will be changed to this status when editing a task which has already been set.
Stopped	A status where the task is stopped. The task can be started because the task setting is completed. A task will be in this status when the setting is completed. In addition, a status will be changed to this status when the running task is stopped and the stopping process is completed normally.
RUN	Preparing A status where the task is running and is preparing for executing processing blocks. A task will be in this status when the task is started. The start processing for preparing each processing block is executed. (Preparation for executing a processing block, such as securing CPU resources and loading an AI model, is performed.)
	Executing A status where the task is running and executing processing blocks. A task will be in this status when the task is started and the preparation process is completed normally. Executing task processing and saving an inspection result history are performed repeatedly.
	Transitioning to stop A status where the task is running and transitioning to the "Stopped" status. A status will be changed to this status when the running task is stopped or an error occurs. The stop processing is performed for each processing block. (Resources secured in the start processing are released and the execution of process in each processing block is canceled at the appropriate timing.)
Stopped due to error	A status where the task cannot be run due to an error. A status will be changed to this status when an error occurs in the running task.

The following table shows the availability of operating a task in each task status.

○: Can be executed, ×: Cannot be executed

Operation	Editing	Stopped	Preparing	Executing	Transitioning to stop	Stopped due to error
Edit	○	○	×	×	×	○
Start	×	○	×	×	×	○ ^{*1}
Stop	×	×	○	○	×	×
Task monitor	○	○	○	○	○	○
Delete	○	○	×	×	×	○
Duplicate	○	○	○	○	○	○
Exporting a project	○	○	○	○	○	○
Deploying an AI model	○	○	×	×	×	×
Deploying a task	×	○	×	×	×	×

*1 If the cause of the error is not resolved, the status will be changed to "Stopped due to error" again.

*2 An error does not occur even when the operation is performed.

*3 The operation may be performed after the task status is changed to 'Stopped' or 'Stopped due to error.'

Execution order of a processing block

The execution order of a processing block placed on the canvas is determined depending on the connection of connectors (order), the placement of processing blocks (priority), and the execution timing of a processing block.

When all processing blocks^{*1} are executed, each block is executed again in the execution order.

*1 Excluding processing blocks placed in the route which does not match a condition using the conditional branch block.

Order of processing blocks

The order of processing blocks depends on the connection of connectors.

When a connector is connected from the output of the processing block A to the input of the processing block B, the block A is executed first, and then the block B is executed.

The order number of a processing block starts from '0.' '0' indicates the processing block where the input is not connected with a connector.

For the order number of processing blocks connected with connectors, the number is incremented by one from a processing block on the input side.

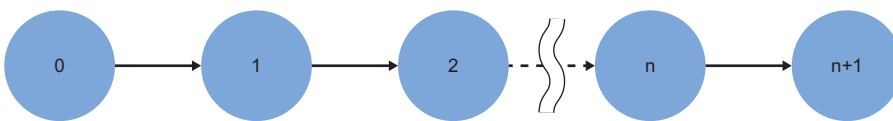

Multiple connectors can be connected to the input and output of a processing block.

■ Connecting the output of the processing block A to the input of multiple processing blocks of B and C

A is executed first, and then B and C are executed.

In this case, the order of B and C is the same; therefore, the execution order of B and C is determined according to their priority.

☞ Page 105 Priority of processing blocks

■ Connecting the output of multiple processing blocks of A and B to the input of the processing block C

A and B are executed first, and then C is executed.

When there are multiple processing blocks on the input side, the order number of C is 'the largest number of A or B + 1.'

Ex.

When connecting from the processing block number 3,5,and 7, the order number of C will be 8.

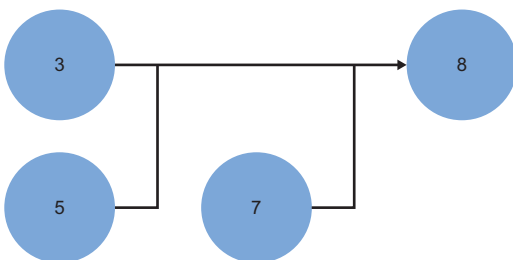

Priority of processing blocks

The priority of processing blocks is determined by the placement of the blocks on the canvas.

If there are processing blocks with the same order number, the blocks placed on the upper side of the canvas will be prioritized first, and then the blocks placed on the left side of the canvas.

Ex.

This example shows the execution order and priority determined from the following flow chart.

Numbers are placed on the upper right of each processing block. The number on the left side indicates the order number, and on the right side indicates priority.

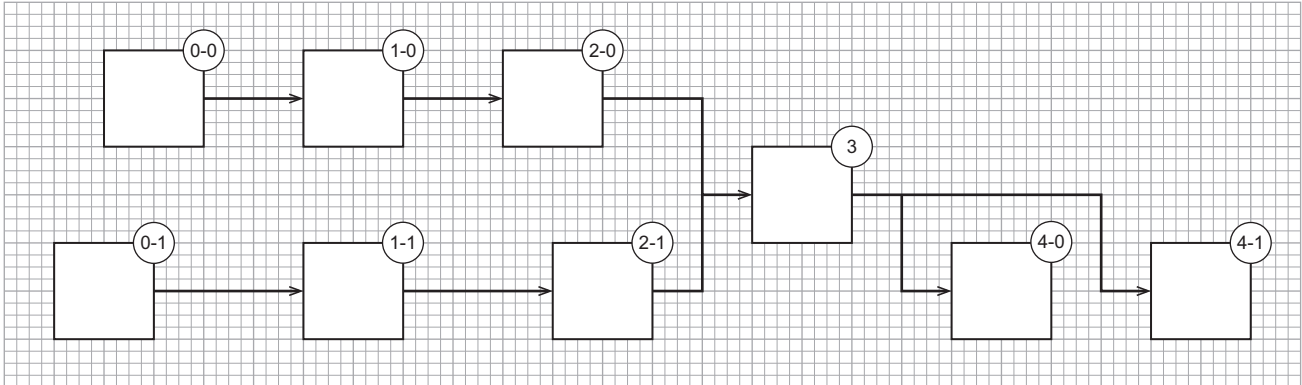

If the execution of some processing blocks is not completed

The execution of the following processing blocks is not completed until the execution condition is satisfied.

- PLC data reading block (for detecting a trigger)
- Image import block
- Monitor input waiting block

If the execution of a processing block is not completed, the execution of the next block will be determined depending on a positional relationship with the block which is not completed.

- For blocks placed in series:

The next processing block is not executed until the input-side processing block is completed.

- For blocks placed in parallel:

A processing block with low priority is executed if the execution of the processing block with high priority is not completed.

To execute a processing block that has multiple inputs, the execution of the previous blocks must be completed.

Ex.

This example shows the execution order of blocks when the trigger condition of the processing block A (PLC data reading block) is not satisfied.

- 1 A is not completed; therefore, B which is placed in parallel to A is executed.
- 2 A is executed again but the execution is not completed because the trigger condition is not satisfied.
- 3 C that is placed in series to A is not executed because the execution of A is not completed. Therefore, D is executed.
- 4 The execution of A is completed because the trigger condition is satisfied.
- 5 C is executed and the next block is executed according to the execution order and priority.
- 6 The execution of E and F which are the input of G is completed; therefore, G is executed. (To execute G, the execution of the previous processing blocks must be completed.)

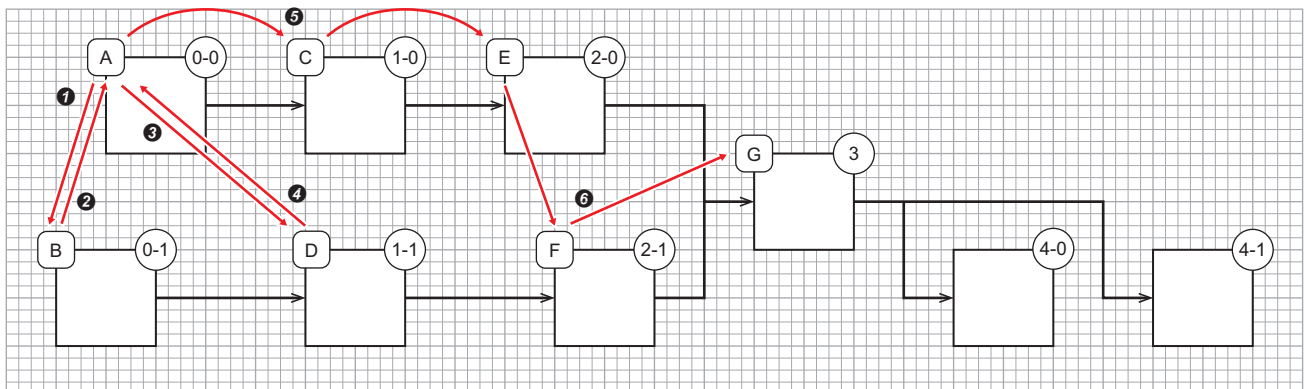

10.2 Creation Procedure for a Task

This section shows the procedure for creating a task.

10

Point

- The procedure for creating a task which uses an AI model differs depending on system configurations.

When using the learning machine and inspection machine in the same personal computer

When the steps from generating an AI model to creating a task will be performed in series or when an AI model to be used for a task is already determined, a task can be created by using an AI model selected in the AI model management screen.



 Page 83 AI Model Management Screen

When using the learning machine and inspection machine in different personal computers

A task can be created by using an AI model deployed from the learning machine to the inspection machine. Alternatively, a task can be created by creating a task, which uses an AI model, in the learning machine, and then by deploying it to the inspection machine.

 Page 80 Deployment Procedure for an AI Model

 Page 115 Deployment Procedure for a Task

1. Create a new task. ( Page 107 Creating a new task)
2. Set the task. ( Page 109 Setting a task)

Creating a new task

The following shows the procedure for creating a new task.

Point

- A task can also be created by duplicating a created task.

 Page 118 Task Management Screen

Operating procedure

1. Click the [New] button in the task management screen. ( Page 118 Task Management Screen)

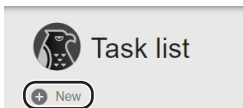

Point

A task can also be created by specifying an AI model.

 Page 83 AI Model Management Screen

2. Set the task information and click the [OK] button.

New task creation

Name

Comment

Item	Description
Name	Set a task name (1 to 32 characters).
Comment	Set a comment (0 to 1024 characters).

3. Select a task template to be used, and click the [OK] button.

By using a task template, basic processing blocks already connected to each other are placed on the canvas in the task setting screen. Therefore, a task flow can be set by only setting the processing blocks.

Task template selection
Please select the task template to be used.

Not use

Imaging (Imaging instruction by PLC data reading) ?

Imaging (Imaging instruction by manual operation) ?

Import captured image ?

Point

Only the AI model for anomaly detection can be placed for the anomaly detection block which is set in a task template.

When using an AI model for defective point detection, place the defective point detection block after selecting a task template.

Setting a task

The following shows the procedure for setting each processing block which runs on a task, a task flow, and an inspection result history.

In the task setting, processing blocks and a task flow are represented in a flow format (a format that connects a contact (2) between the placed processing blocks (1) using a connector (3)). By doing so, the behavior of a task can be set with an intuitive operation.

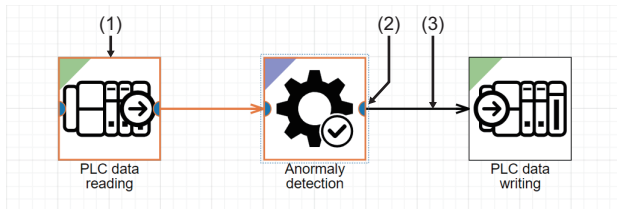

The setting procedure of a task is as follows:

Operating procedure

1. Select a task to be set in the task management screen, and click the [Edit] button. (☞ Page 118 Task Management Screen)

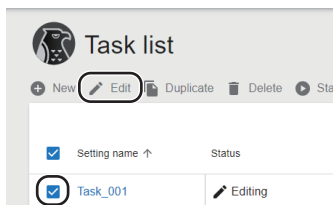

2. Add processing blocks. (☞ Page 110 Placing a processing block)
3. Set the processing blocks. (☞ Page 111 Setting a processing block)
4. Set an inspection result history. (☞ Page 112 Setting the inspection result history)
5. Click the [Complete] button.

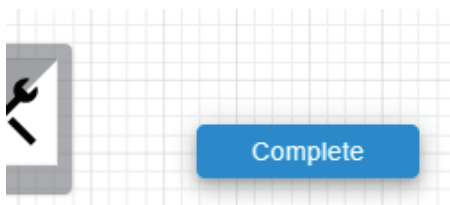

When task settings are completed, the task status becomes 'Stopped.'

When a task status is other than 'Editing,' the task setting screen is read-only. The read-only can be cleared by clicking the [Edit] button in the task setting screen.

Point

When using a processing block which links with any of the following devices, the availability of linking the device can be checked in a task setting by preparing the device in advance.

- Camera: ☞ Page 145 Imaging block
- Programmable controller: ☞ Page 126 PLC data reading block, Page 139 PLC data writing block
- File server: ☞ Page 112 Setting the inspection result history, Page 152 Image import block

Placing a processing block

The following shows the procedure for placing a processing block in the task setting screen. (☞ Page 122 Task Flow Setting Screen)

1. Select a processing block to be placed from a dock.

For available processing blocks, refer to the following:

☞ Page 125 Processing Block List

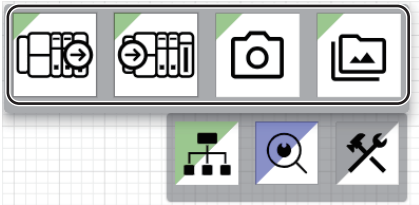

The processing block is placed on the canvas.

2. Connect processing blocks with a connector.

Drag the contact (1) of the processing block and drop it to the contact (2) of a processing block to be connected.

When the blocks are connected with the connector, the line is changed from a dashed line to a solid line.

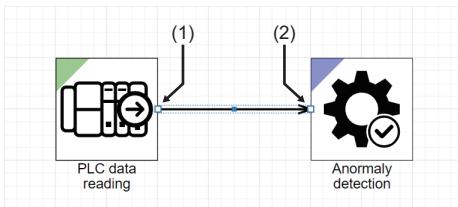

The connection target of a connector can be changed by selecting a connector and then dragging and dropping the contact (3) of the connector.

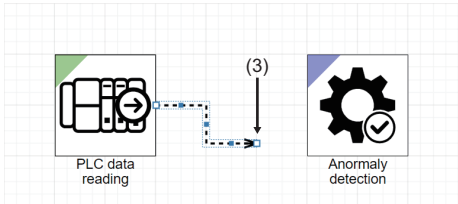

The route of a connector can be changed by selecting a connector and then dragging and dropping the moving point (4) of the connector.

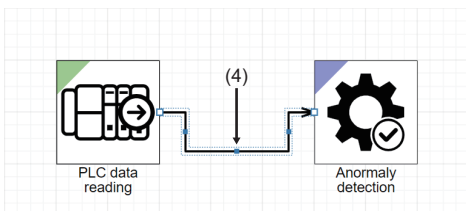

Point

For the execution order of processing blocks placed on the canvas, refer to the following:

☞ Page 104 Execution order of a processing block

Precautions

- Connecting blocks to loop a task flow is not available.
- Multiple connection from the same connection source processing block to the same connection destination block is not available.
- Multiple task flows cannot be set for one task.

Setting a processing block

The following shows the procedure for setting the behavior of a placed processing block.

1. Right-click a placed processing block and select [Edit].

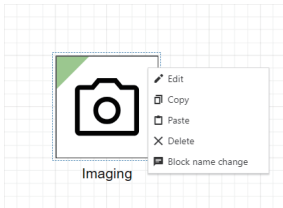

2. Set the behavior of the processing block.

For setting contents of each processing block, refer to the following:

📖 Page 125 PROCESSING BLOCK

Setting the inspection result history

The following shows the procedure for setting the saving action of an inspection result history.

1. Click the [Inspection result history] button in the task setting screen. (☞ Page 122 Task Flow Setting Screen)

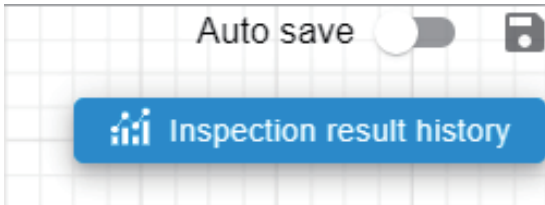

2. Select data to be saved, and click the [NEXT] button.

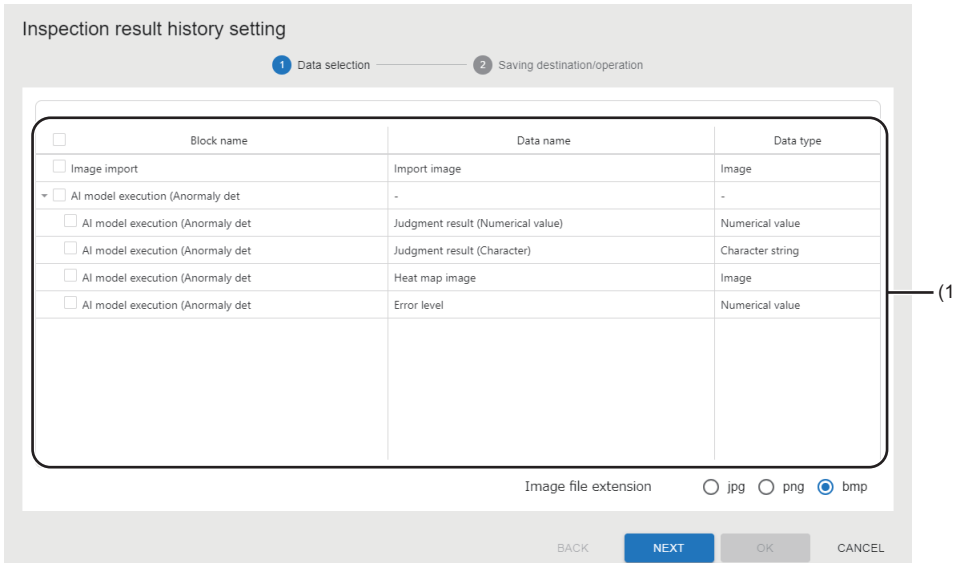

Item	Description	
(1) Data list	Block name	The names of the following processing blocks used in a task flow are displayed. <ul style="list-style-type: none"> • PLC data reading • Imaging • Image import • Anomaly detection • Defective point detection
	Data name	The data name of output data is displayed.*1
	Data type	The data type of output data is displayed.
Image file extension	Select an extension of an image to be saved. To keep the save size down, select an extension other than bmp.	

*1 If the processing block is "PLC data reading," "Comment" set in the device/trigger setting is also displayed. (☞ Page 129 PLC data reading screen (device/trigger setting))

Point

If there is no output data of the save target due to conditional branch or an error occurred in a processing block, saving the corresponding output data is skipped and available data is saved.

Additionally, only the start date and time is saved as the inspection result history in the following cases:

- No data is selected.
- Saving data process is skipped for all output data.

3. Set a saving destination and the behavior of saving data, and click the [OK] button.

Item	Description	
History saving	Turn ON the switch to save an inspection result history.	
Saving destination	Specify the saving destination path (up to 100 characters) of an inspection result history. By clicking the button, up to 10 saving destinations*1 which were set in the project in the past are displayed. Click the [SAVING TEST] button to perform a saving test for the specified saving destination. (Page 114 Saving test)	
Operation at failure	Stop the task	Select this to treat a saving failure as an error and stop the task operation.
	Continue the task	Select this to treat a saving failure as a warning and continue the task operation.
Saving period	Specification of the number of days*2	Select this to specify the saving period of inspection result histories in days (1 to 365).
	Specification of the number of items*2	Select this to specify the saving period of inspection result histories by setting the number of the result histories to be saved (10,000 to 10,000,000). When a task is executed every three seconds, the number of inspection result histories reaches 10,000,000 in approximately 12 months. When the save size of each inspection result history is 2 MB, the maximum 20 TB of capacity is required.
	No specification	Select this to not specify the saving period of inspection result histories. Inspection result histories are not deleted automatically; therefore, they are saved until the free storage space of the saving destination becomes full. Delete the histories manually as necessary.

*1 If the number of pieces of past information exceeds 10, the information will be deleted in chronological order.

*2 If the period exceeds the set saving period, inspection result histories will be deleted in chronological order.

To prevent the histories to be deleted, perform a measure described in the following:

Page 114 Methods for preventing an inspection result history to be deleted

Point

- The available capacity for a saving destination can be verified with the formula stated below. The formula uses a save size which can be checked in the inspection result history check screen, saving frequencies (the average value of a saving cycle calculated from the date and time column), and a saving period set in this screen. (Page 171 Inspection Result History Check Screen)
Save size × (Saving period/saving frequencies) < Available capacity for a saving destination
- For the folder configuration of a inspection result history, refer to the following:
(Page 187 Inspection result history)

Precautions

- Saving and deleting inspection result histories and performing saving test for the histories are performed by a Windows logon user on the accessing learning or inspection machine. Therefore, write and delete permissions for a specified saving destination folder must be granted to the user.
- When saving inspection result histories from several learning or inspection machines to the same file server, specify different saving destination folders. When saving the histories to the same saving destination, make sure that project and task names are not duplicated. (If saving destinations are the same and project and task names are duplicated, a folder named in the form of 'task name_IP Address' is created and the histories are saved in the folder.)
- Do not edit, move, or delete a folder or file in the saving destination of an inspection result history. Otherwise, this product may not run properly.
- Task processing is performed simultaneously with saving the inspection result history. The next task processing and saving the inspection result history are not started until the previous inspection result history is saved. Therefore, if saving an inspection result history takes time, the start of the next task processing may be delayed.

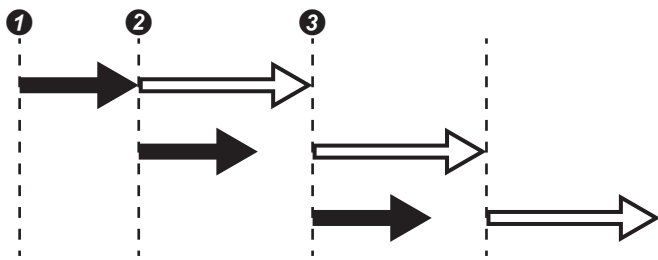

→: Task processing, ⇨: Saving an inspection result history

- 1 The first task processing starts.
 - 2 The second task processing is executed and the inspection result history for the first task processing is saved when the first task processing is completed.
 - 3 The third task processing is executed and the inspection result history for the second task processing is saved when saving the inspection result history for the first task processing is completed.
- REAL type (single-precision real type) data that is read by the PLC data reading block is converted into the double-precision real type data. Therefore, the numerical value of a read target on the programmable controller side may differ from the one saved in the inspection result history.

■ Saving test

The availability for executing a series of processing required for saving an inspection result history can be checked.

Processing	Test content
Connecting to a saving destination	To connect to a saving destination.
Checking a saving destination folder	To check the presence of a saving destination folder.
Creating a file	To create a test folder in the saving destination folder and create a test file in the test folder.
Deleting a file	To delete the test folder.

■ Methods for preventing an inspection result history to be deleted

An inspection result history will not be deleted by either of the following methods:

- Moving a specified saving destination folder to another place
Note that saving an inspection result history may fail if moving the folder while the saving is in progress. It is recommended to move the folder after stopping the task.
- Changing a saving destination folder
Note that the task must be stopped to change the task setting.

10.3 Deployment Procedure for a Task

This section shows the procedure for connecting to another personal computer and duplicating the created task. When using an AI model in the task, the AI model is also duplicated at the same time.

A task is deployed for the following purpose:

- Duplicating a task created in the learning machine to the inspection machine and setting external link devices (such as a programmable controller, camera, and an image saving destination) again on the inspection machine side.
- Duplicating a task being used in the inspection machine to another one for utilizing the task to another inspection machine on a manufacturing line, which manufactures the same product.



10

Precautions

To deploy a task, the operation status of this product on the personal computer of a deployment destination must be in the running status.

 Page 33 Startup tool

Operating procedure

1. Select a task to be deployed in the task management screen, click  (Other options), and then select [Deploy].
( Page 118 Task Management Screen)

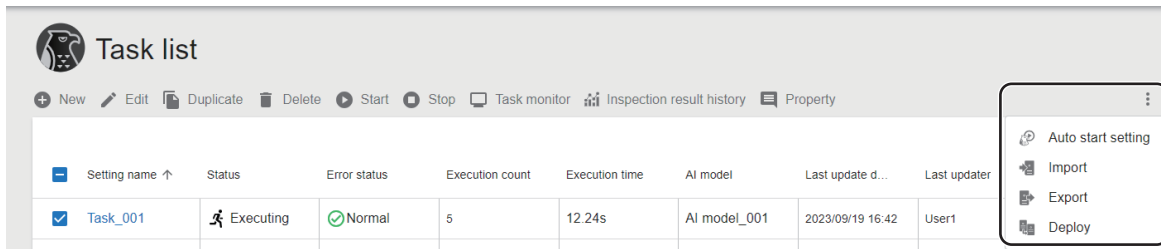

2. Enter the information of a deployment destination in the connection destination setting screen, and click [Connect] button.

Connection destination setting
Please input the information on the deployment destination.

IP address 
Please input a value.

Port number
Please input a value.

User ID

Input password
Please input a value.

Item	Description
	Click this to display the information of up to 10 connection destination settings ^{*1} which have been used in the past. By selecting a setting from the history, information other than the password is applied.
IP address	Enter the IP address of a connection destination.
Port number	Enter the port number of a connection destination.
User ID	Enter a user ID to be signed in.
Input password	Enter the password of a user ID to be signed in.

*1 If the number of pieces of past information exceeds 10, the information will be deleted in chronological order.

3. Select a project of a deployment destination in the deployment setting screen, and click the [Deploy] button.

Deployment setting

Please select a project in the deployment destination.

Setting name ↑	Number of AI mo...	Number of tasks	Last update date ...	Comment
Project_001	3	1	2023/09/01 12:02	
Project_002	1	0	2023/08/30 17:14	
Project_003	0	0	2023/08/30 11:39	

(1)

Deploy Cancel

Item	Description	
(1) Project list*1	Setting name	A project name is displayed.
	Number of AI models	The number of AI models set for a project is displayed.
	Number of tasks	The number of tasks set for a project is displayed.
	Last update date and time	The last date and time when a project was updated is displayed.
	Comment	A comment set for a project is displayed.

*1 The following project cannot be selected: A project that a user who is signed in from the connection destination setting screen does not have access authority or does not have the full control authority for its tasks.

Point

After deploying a project, it is recommended to change its task name to one which is unique in the deployment source project and deployment destination project.

The inspection result history of a task is saved into a folder with the name of the task. Therefore, the inspection result history of a corresponding task can be easily identified from its folder name even when using settings including the inspection result history setting as they are (except for the task name).

Precautions

- If a task name is duplicated with the one in the deployment destination, a serial number is attached to the name in the same way as the setting name described below.
(☞ Page 119 Behavior when a task is duplicated)
- If the deployment fails when multiple tasks are selected in the task list screen, the tasks will be deployed except the failed ones.

10.4 Task Management Screen

This section shows the screen for setting, stating or stopping, and monitoring tasks.

Window

Click (Task) on the side bar. (Page 40 Side bar)

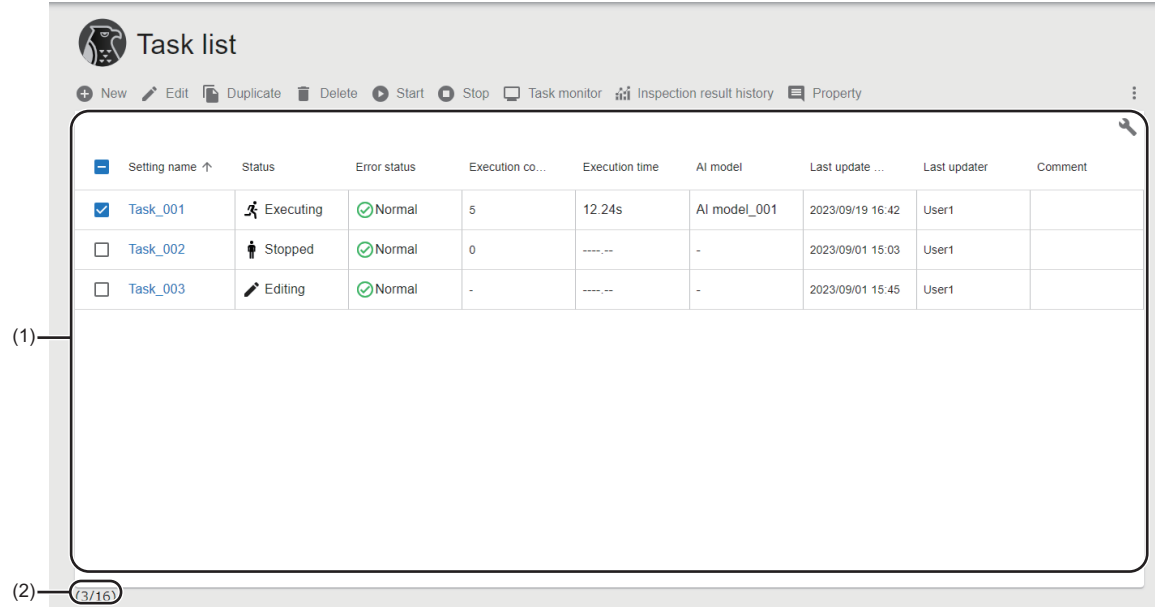

Displayed items

Item	Description	
New	Click this to create a new task. Page 107 Creating a new task	
Edit	Click this to edit a selected task. Page 122 Task Flow Setting Screen	
Duplicate	Click this to duplicate a selected task. For the contents of the duplicated task, refer to the following: Page 119 Behavior when a task is duplicated If the duplication fails when multiple tasks are selected, the duplication of a task which failed to be duplicated and subsequent tasks will be canceled. (If the number of tasks after duplication exceeds the maximum number, the duplication of all tasks will be canceled.)	
Delete	Click this to delete a selected task. If the deletion fails when multiple tasks are selected, the tasks will be deleted except the failed ones.	
Start	Click this to execute a selected task. Page 163 Operation Procedure for a Task	
Stop	Click this to stop a selected task.	
Task monitor	Click this to monitor a selected task. Page 164 Checking a task status	
Inspection result history	Click this to check the inspection result history of a selected task. Page 165 Checking an inspection result history	
Property	Click this to check or change the properties of a selected task. Page 120 Task properties	
(Other options)	Auto start setting	Click this to configure the auto start setting for a selected task. Page 121 Auto start setting
	Import	Click this to import a task created in another personal computer. Settings that are already created in a project will not be deleted even if the import fails during the process. Page 53 Import
	Export	Click this to export a task so that it can be utilized in other personal computers. Page 52 Export
	Deploy	Click this to connect to another personal computer and duplicate a created task. Page 115 Deployment Procedure for a Task

Item	Description	
(1) Task list	Setting name	A task name is displayed. The task flow setting screen appears by clicking the task name. ☞ Page 122 Task Flow Setting Screen
	Status	The status of a task is displayed. ☞ Page 103 Task status
	Error status	The error status of a task is displayed. When an error occurs, the error code is displayed on the tooltip of the icon.
	Execution count	The number of times a task is executed (a cumulative total since the start of the task) is displayed. When a task is in 'Stopped' status, the execution count of the previous task processing is displayed.
	Execution time	The execution time (the time taken for executing a task once) is displayed.
	AI model	An AI model set in a task is displayed.
	Number of AI models ^{*1}	The number of AI models set in a task is displayed.
	Auto start setting ^{*1}	Whether the auto start setting is enabled or disabled is displayed.
	Size (MB) ^{*1}	The file size ^{*2} of a task setting is displayed.
	Creation date and time ^{*1}	The date and time when a task was created is displayed.
	Creator ^{*1}	The ID of a user who created a task is displayed.
	Last update date and time	The last date and time ^{*3} when a task was updated is displayed.
	Last updater	The ID of a user who last updated a task is displayed.
Comment	A set comment is displayed.	
(2) Number of settings	The number of created tasks and the maximum number of tasks that can be created are displayed.	

*1 Displayed by expanding the header.

☞ Page 41 Expanding the header

*2 The file size is the same as that of a task for deployment and that of a task setting in a project file for export.

*3 It is not changed even when changing the properties.

Behavior when a task is duplicated

Contents of a duplicated task are changed as follows

Item	Description
Setting name	A three-digit number with zero padding is added to the end of the setting name of the duplicate source. The initial value '(001)' is added to the end of the setting name and it is incremented to prevent the name from being duplicated with other tasks. ^{*1} If the setting name exceeds the maximum number of characters (32 characters) after duplication, characters after the first 27 characters are deleted from the name and the number is added.
Status	It is changed to 'Stopped' when the status of the duplicate source is other than 'Editing.'
Creation date and time	It is changed to the date and time when the task is duplicated.
Others	They are not changed from the duplicate source.

*1 Characters are not case-sensitive when checking duplication of names.

Task properties

The following operations can be performed: changing the name and comment of a task and checking the property information.

Window

Select a task in the task management screen, and click the [Property] button. (☞ Page 118 Task Management Screen)

Property of Task_001

Name: Task_001

Comment:

(1)

Creation date and time : 2023/08/31 18:53
Last update date and time : 2023/09/01 15:34
Size (MB) : 0.1(MB)
Status : Stopped
Execution time : 0s
AI model : AI model_001
Number of AI models : 1
Execution count : 0
Last updater : User1
Creator : User1

OK Cancel

Displayed items

Item	Description
Name	Set a task name (1 to 32 characters).
Comment	Set a comment (0 to 1024 characters).
(1) Property information	The property information of a task is displayed.

Point

The last update date and time of a task is not changed even when changing a name and comment.

Auto start setting

The following shows the screen for enabling or disabling for the auto-start of a task.

By enabling the setting, a task can be started automatically at the same timing when the operating status of this product changes to "RUN."

Point

- By also setting the auto start of the start up tool, a task can be run automatically at Windows logon after the personal computer starts. (☞ Page 34 Auto start)
- A user ID for events and errors related to the auto-started tasks will be '@system.'

Window

1. Select a task in the task management screen. (☞ Page 118 Task Management Screen)
2. Click ☰ (Other options), and select [Auto start setting].

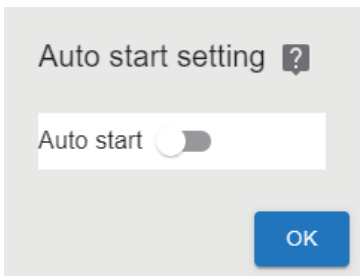

Displayed items

Item	Description
Auto start	Turn ON the switch to enable a task to be started automatically.

10.5 Task Flow Setting Screen

This section shows the screen for setting each processing block which runs on a task, a task flow, and the inspection result history of a task.

Window

Select a task to be set in the task management screen, and click the [Edit] button. (☞ Page 118 Task Management Screen)

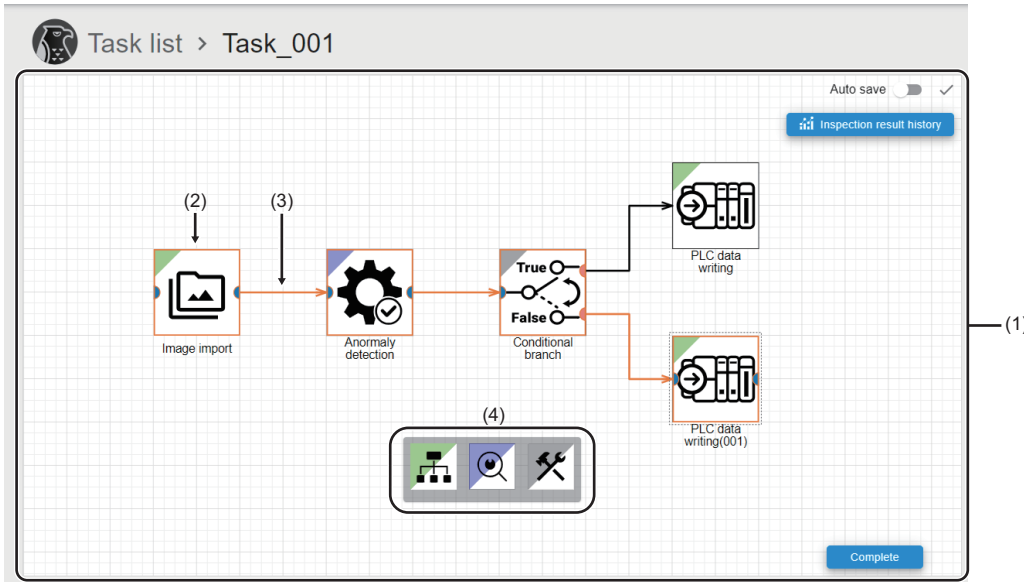





Displayed items

Item	Description
Auto save	Turn ON the switch to save the canvas automatically when layout is changed in the canvas.
(Save)	Click this to save a layout and its contents in the canvas. <input checked="" type="checkbox"/> is displayed if no layout is changed.
(1) Canvas	An area for placing processing blocks and connectors. ☞ Page 110 Placing a processing block The canvas area is extended by placing a processing block or connector outside the area.
[Inspection result history] button	Click this to set an inspection result history. ☞ Page 112 Setting the inspection result history
(2) Processing block	A block which represents each processing of a task. The setting screen of a processing block appears by double-clicking it. For setting contents of each processing block, refer to the following: ☞ Page 125 PROCESSING BLOCK For the status and menus of processing blocks, refer to the following: ☞ Page 123 Processing block status, Page 123 Menus of processing blocks
(3) Connector	A connector which represents a data flow between processing blocks. <ul style="list-style-type: none"> Solid line: Processing blocks are connected. Dashed line: Processing blocks are not connected. For the menus of connectors, refer to the following: ☞ Page 123 Menus of connectors
(4) Dock	Select a processing block to be added. For available processing blocks, refer to the following: ☞ Page 125 Processing Block List
[Complete] button	Click this to complete a task setting so that the task can be started.
[Edit] button	Click this to edit a task

Processing block status

The following shows the status of a processing block.

Status	Icon	Description
Normal		A status where the processing block can be edited
Error		A status where an error occurs in the processing block. The error details are displayed by clicking  .
Read-only		A status where the processing block is read-only

Menus of processing blocks

The following table shows the menus displayed when right-clicking a processing block.

Menu	Description
Edit	To open the setting screen of a processing block.
Copy	To copy the selected processing block.
Paste	To paste a copied processing block.
Delete	To delete the selected processing block.
Block name change	To open the block name change screen of the selected processing block.  Page 124 Changing a block name

Menus of connectors

The following table shows the menus displayed when right-clicking a connector.

Menu	Description
Copy	To copy the selected connector.
Paste	To paste a copied connector.
Delete	To delete the selected connector.

Changing a block name

The following shows the screen for changing a processing block name.

Point

By changing the name of a processing block to a unique name, a target processing block can be easily identified in the monitor or an inspection result history.

Window

Right-click a processing block in the task setting screen, and select [Block name change]. ( Page 122 Task Flow Setting Screen)

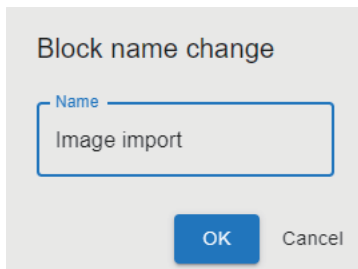

Block name change

Name

Image import

OK Cancel

Displayed items

Item	Description
Name	Set a processing block name (1 to 32 characters).











11 PROCESSING BLOCK

This chapter shows the types and specifications of processing blocks.

11.1 Processing Block List

This section shows the list of processing blocks.

○: Available, ×: Not available

Category	Processing block	Placement		Feature and purpose	Maximum number of settings* ¹ per task	Reference
		Beginning	End			
Machine integration 	PLC data reading 	○		To read device values from a programmable controller. The trigger condition of the next processing block can be specified based on the read device values.	8	Page 126 PLC data reading block
	PLC data writing 	○		To write device values to a programmable controller. The information of a processing block on the task flow is used for device values to be written.	8	Page 139 PLC data writing block
	Imaging 	○		To capture an image with a camera	8	Page 145 Imaging block
	Image import 	○		To import image files in a folder from a file server	8	Page 152 Image import block
AI model inspection 	Anomaly detection 	× ^{*2}	○	To specify an AI model generated with the learning machine, to perform preprocessing for an input image, and to perform inference using an AI model	8	Page 155 AI model execution blocks
	Defective point detection 	× ^{*2}	○		8	
Utility 	Conditional branch 	× ^{*3}	○	To specify conditions and branch a task flow. The information of a processing block on the task flow is used for branch conditions.	8	Page 159 Conditional branch block
	Monitor input waiting 	○ ^{*4}		To pause a task flow. A task flow can be restarted from the task monitor screen.	8	Page 162 Monitor input waiting block

*1 Each total number of processing blocks and connectors that can be set per task is as follows:

- Processing block: 1 to 32
- Connector: 0 to 40

*2 Place the imaging block or image import block in the previous block.

*3 Place the PLC data reading block or AI model execution block in the previous processing block.

*4 Cannot connect to the same processing block.

11.2 Machine Integration Category

This section explains processing blocks in the machine integration category. These blocks communicate with another device (a programmable controller, camera, or file server) and execute processing.

PLC data reading block

The PLC data reading block reads device values from a programmable controller. The device values that are read by this block can be used for executing a task.

For example, when the information of an inspection target (such as a manufacturing number) is held in a programmable controller, reading its device value allows the information to be saved as an inspection result history with other pieces of data (such as captured images and the inspection result), which are acquired at task execution.

Additionally, this block can perform trigger detection for the read device values to monitor whether or not a specified condition is satisfied. By performing trigger detection, the execution start timing of the next block can be controlled by a programmable controller. (For example, a capturing timing can be controlled by a programmable controller by placing the imaging block next to this block.)

Input/output specifications

The following shows the input and output specifications of this block.

■ Input

None

■ Output

Data name	Data type	Description
Read device value	Numerical value	When the data type to be read is other than 'STRING' or 'WSTRING'
	Character string	When the data type to be read is 'STRING' or 'WSTRING'

PLC data reading screen (programmable controller connection setting)

The following shows the screen for setting the information of a programmable controller to be connected.

Window

The screenshot displays the 'PLC data reading' window with two tabs: '1 Programmable controller connection setting' (active) and '2 Device/trigger setting'. The 'General setting' section includes 'CPU series' and 'CPU type' dropdown menus, both with red error messages 'Please input a value.' and a blue 'OPERATION DETAIL SETTING' button. The 'PC-side interface setting' section includes a 'PC-side interface' dropdown, an 'IP address' input field with a red error message, and 'Network number' and 'Station number' input fields, both set to '1'. The 'Machine-side interface setting' section includes a 'Machine-side interface' dropdown, a 'Protocol type' dropdown set to 'TCP', and 'IP address', 'Network number', and 'Station number' input fields, with 'Network number' and 'Station number' set to '1'. A 'COMMUNICATION TEST' button is located at the bottom left. At the bottom right, there are 'BACK', 'NEXT', 'OK', and 'CANCEL' buttons.

11

Displayed items

Item	Description	
General setting	CPU series	Select CPU series to be connected.
	CPU type	Select a CPU type to be connected.
	[OPERATION DETAIL SETTING] button	Click this to configure the detailed settings for communication with the CPU. (Page 128 Operation detail setting screen)
		Click this to display up to 10 programmable controller connection settings*1 which have been set for the project in the past. (Page 128 Connection destination setting history screen)
PC-side interface setting	PC-side interface	Select the interface of a personal computer to be connected.
	IP address	Specify the IP address of a personal computer side interface to be connected.
	Network number	Specify the network number of a personal computer side interface to be connected.
	Station number	Specify the station number of a personal computer side interface to be connected.
Machine-side interface setting	Machine-side interface	Select a machine side interface type.
	Protocol type	Select a protocol type.
	IP address	Specify the IP address of a CPU or machine side interface to be connected.
	Network number	Specify the network number of a CPU to be connected.
	Station number	Specify the station number of a CPU to be connected.
[COMMUNICATION TEST] button	Click this to perform a communication test with a programmable controller.	

*1 If the number of pieces of past information exceeds 10, the information will be deleted in chronological order.

■ Operation detail setting screen

Window

Operation detail setting

Timeout time s

Number of retries

Displayed items

Item	Description
Timeout time	Set a communication timeout time. (1 to 90 [s])
Number of retries	Set the number of retries (0 to 9) due to communication failure.

■ Connection destination setting history screen

Window

Connection destination setting history

Please select the programmable controller connection destination setting to be used.

(1)

Displayed items

Item	Description
(1) History list	Programmable controller connection settings which have been set in the past are displayed.

PLC data reading screen (device/trigger setting)

The following shows the screen for setting a read target.

Window

- Device

PLC data reading

✓ Programmable controller connection setting — 2 Device/trigger setting

DEVICE TRIGGER

Please set the device to be read.

	Device	Data type	Number of characters	Comment
<input type="checkbox"/>	<input type="text" value=""/>	BOOL	<input type="text" value=""/>	<input type="text" value=""/>

Please input a value.

BACK NEXT OK CANCEL

- Trigger

PLC data reading

✓ Programmable controller connection setting — 2 Device/trigger setting

DEVICE TRIGGER

Detect trigger

Trigger condition setting

Value change

Monitoring target: Establishment condition:

Value comparison

Monitoring target: Comparison condition:

Comparison target selection: Comparison target (Fixed value):

Monitoring cycle setting

ms

BACK NEXT OK CANCEL

Displayed items

Item		Description	
[Device] tab	+ (Add)	Click this to create the setting of a device to be read. (Up to 20 settings)	
	☒ (Delete)	Click this to delete the selected setting.	
	Device	Set the type and device number of a read target device.	
	Data type	Select a data type to be read.	
	Number of characters	Specify the number of characters to be read. This must be set when selecting "STRING" or "WSTRING" for a data type. <ul style="list-style-type: none"> • STRING: 1 to 32 • WSTRING: 1 to 16 	
	Comment	Enter a comment (0 to 64 characters). The entered comment can be checked from the task monitor screen and an inspection result history.	
[Trigger] tab	Detect trigger	Turn ON the switch to use the trigger detection function.	
	Trigger condition setting	Value change	A trigger is satisfied when a monitoring target device value (BOOL type) matches with the set condition. <ul style="list-style-type: none"> • Monitoring target: Select a device (BOOL type) to be used as a trigger.*1 • Establishment condition: Select a value change condition to satisfy a trigger.
		Value comparison	A trigger is satisfied when a monitoring target device value matches with the set comparison condition. <ul style="list-style-type: none"> • Monitoring target: Select a device to be used as a trigger.*1 • Comparison condition: Select a condition for comparing values. • Comparison target selection: Select a target to compare with the monitoring target. • Comparison target (Fixed value)²: Enter the fixed value³ of a comparison target. • Comparison target device selection⁴: Select a device to be compared.*5
	Monitoring cycle setting	Set the monitoring cycle (300 to 86400 [ms]) of a device to be used for trigger detection.	

*1 Can be selected from devices set in the [Device] tab.

*2 Displayed when selecting "Fixed value" for "Comparison target selection."

*3 When the data type of "Monitoring target" is a character string, the following number of characters can be entered:
 STRING: 1 to 32 characters
 WSTRING: 1 to 16 characters

*4 Displayed when selecting "Device" for "Comparison target selection."

*5 Select a device which satisfies the following conditions from devices set in the [Device] tab.
 - The device is not selected for "Monitoring target."
 - The data type (a numerical value or character string) is the same as the one selected for "Monitoring target."

Precautions

- When a single-precision real number is compared with a double-precision real number in "Value comparison," conditions may be satisfied or not satisfied unintentionally due to the differences in accuracy.
- Processing to read data from a programmable controller may take time due to an operation environment or a communication route. In this case, a trigger monitoring cycle does not depend on the set value but depends on the processing time of reading data from a programmable controller.

Operational specifications (while editing a task)

This block sets a read target and the connection destination of a programmable controller.

Additionally, the block can perform a communication test with a programmable controller. If no response is returned from the programmable controller until the timeout time elapses, it disconnects communication without retry and ends the communication test.

Operational specifications (while a task is running)

This block reads the device values of a programmable controller and outputs them to a data stream. Additionally, the block performs a trigger conditional judgment based on the read device values and controls a task flow.

The block connects to a programmable controller during the start processing (preparing) and maintains the connection to the programmable controller while a task is running. The block also reads data from the programmable controller and performs a trigger conditional judgment at each execution of the block.

If the connection to the programmable controller is disconnected while a task is running, the block connects to the programmable controller again at the timing of when data is read from the programmable controller.

Behavior when a response timeout error occurs

If an abnormal response (due to disconnection or communication timeout) is received from a connection destination device after a communication request is sent to the device, the request is retried. An error event is registered if the request is retried up to the set number of times but an abnormal response is received after the last retry is attempted. (Once communication processing is successful, the number of retries is reset when the processing is successful.)

Ex.

The following figure shows the timing that an error event is registered when the number of retries is set to two.

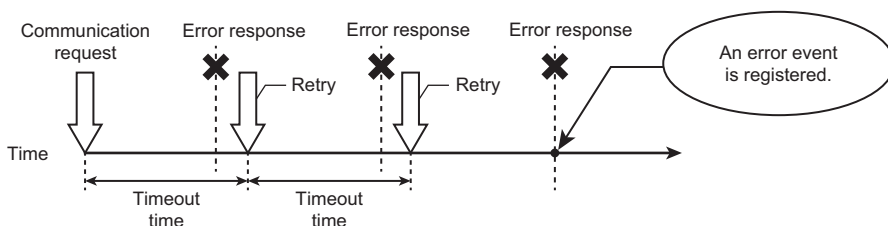

Start processing (preparing)

The block connects to a programmable controller set in the programmable controller connection setting. (If the connection between the block and a programmable controller is already established, the connection processing is not performed.)

Processing block execution (executing)

The block reads device values and outputs the values to a data stream.

When performing trigger detection, the block reads data from a programmable controller and performs a trigger conditional judgment repeatedly in the set monitoring cycle until a trigger is detected. (The block outputs the read values to a data stream after a trigger is detected.)

- PLC data reading

The block reads a device specified in the device/trigger setting in the specified data type. ^{*1}

The read data is used in a trigger conditional judgment or the processing of other blocks with the read data type.

*1 When a trigger detection is turned ON, the data that is read at when a trigger condition is satisfied is treated as output data.

• Trigger conditional judgment

The block determines whether or not a trigger condition is satisfied according to the condition set in the device/trigger setting.

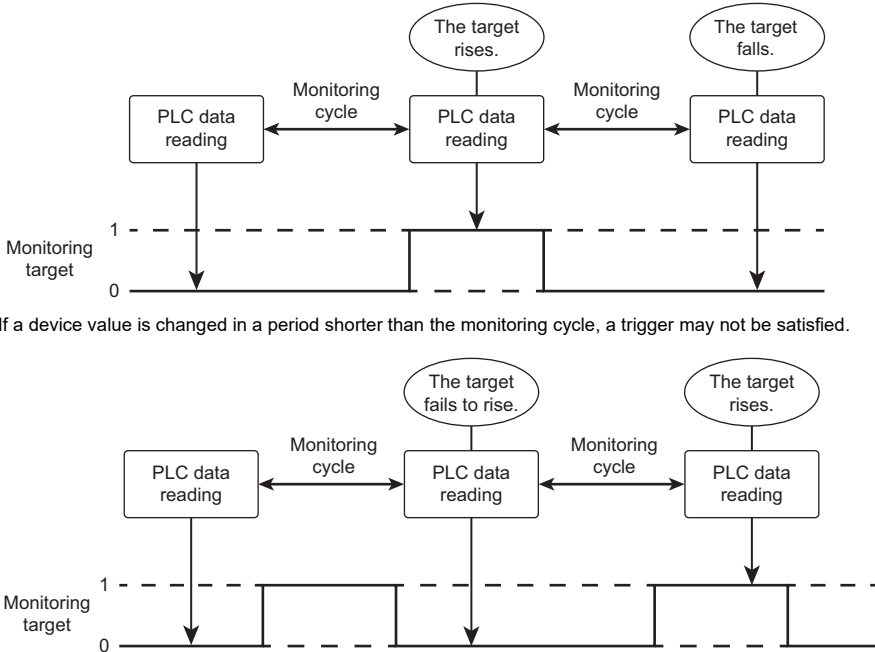
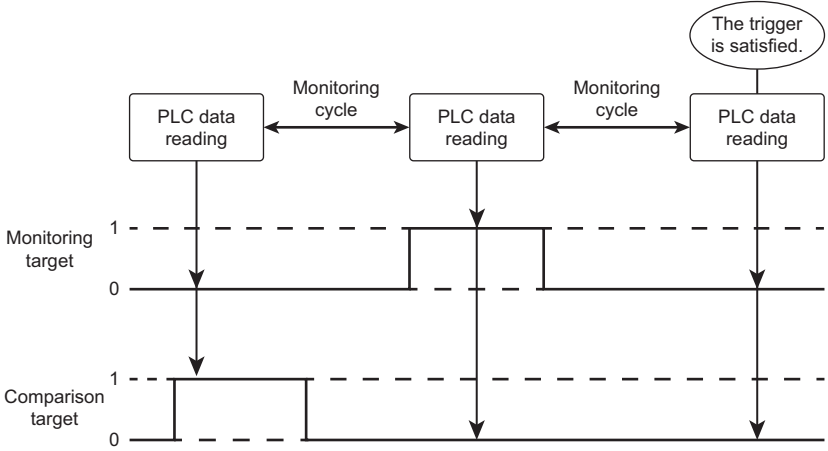
Item	Description
Value change	<p>A trigger is satisfied when this block detects a value change (rising or falling) in a device to be monitored. (After reading data from a programmable controller, the block detects the rise or fall of the device value at the next read.) The block acquires the device value at when a trigger is satisfied and transitions to the next operation.</p>  <p>If a device value is changed in a period shorter than the monitoring cycle, a trigger may not be satisfied.</p>
Value comparison	<p>A condition and target to be compared with the device value of a monitoring target are set and a trigger is satisfied at the timing when the device value of the monitoring target matches with the set comparison condition. (Example) Behavior when a bit device is set both for a monitoring target and a comparison target and '=' (equal)' is set for a comparison condition</p>  <p>To create a task flow with multiple trigger establishment conditions, use multiple PLC data reading blocks and connect their connectors to the same block. This enables the processing block, which is placed next to the PLC data reading blocks, to be executed after all triggers are satisfied. However, the execution of the PLC data reading blocks is completed once their triggers are satisfied; therefore, the triggers may not always be satisfied at the execution timing of the next processing block.</p>

• Output

The block converts the read device values into the data type for output and outputs the values to a data stream.

Item	Description
Numerical value	A value is converted to a numerical value by referring only to the bit range of a data type.
Characters	<p>A value is converted to a character by referring to the range according to the specified data type and the number of characters. ■For control codes NUL is considered as a termination character. Other control codes (0x01 to 0x1F, and 0x7F) are output by replacing them with asterisks (0x2A).</p>

■ Stop processing (transitioning to stop)

The start processing (preparing) is canceled when it is in progress. Additionally, the connection with a programmable controller is disconnected.

When the processing block execution is in progress, the stop processing is executed as follows:

- PLC data reading: The stop processing is executed after the processing block execution is completed. Additionally, the connection with a programmable controller is disconnected.
- Conditional judgment: Conditional judgment processing is canceled. Additionally, the connection with a programmable controller is disconnected.

Accessible devices

The following shows the list of accessible devices.

Accessible devices differ depending on the type of an access target CPU module. (📖 Page 12 Accessible CPU modules)

Precautions

Note that bit-specified devices, digit-specified devices, indirect-specified devices, and index-modified devices cannot be specified.

■ RCPU

Device name	Device type	Data type	Start address	End address	Address representation
X	Bit	BOOL	0	2FFF	Hexadecimal
Y	Bit	BOOL	0	2FFF	Hexadecimal
B	Bit	BOOL	0	9A61FFF	Hexadecimal
CC	Bit	BOOL	0	8993439	Decimal
CN	Word	WORD	0	8993439	Decimal
CS	Bit	BOOL	0	8993439	Decimal
D	Word	WORD	0	10117631	Decimal
F	Bit	BOOL	0	32767	Decimal
JnB ^{*1}	Bit	BOOL	0	9FFFF	Hexadecimal
JnSB ^{*1}	Bit	BOOL	0	13FF	Hexadecimal
JnSW ^{*1}	Word	WORD	0	13FF	Hexadecimal
JnW ^{*1}	Word	WORD	0	27FFFF	Hexadecimal
JnX ^{*1}	Bit	BOOL	0	27FFF	Hexadecimal
JnY ^{*1}	Bit	BOOL	0	27FFF	Hexadecimal
L	Bit	BOOL	0	32767	Decimal
LCC	Bit	BOOL	0	4761215	Decimal
LCN	Word	DWORD	0	4761215	Decimal
LCS	Bit	BOOL	0	4761215	Decimal
LSTC	Bit	BOOL	0	2529407	Decimal
LSTN	Word	DWORD	0	2529407	Decimal
LSTS	Bit	BOOL	0	2529407	Decimal
LTC	Bit	BOOL	0	2529407	Decimal
LTN	Word	DWORD	0	2529407	Decimal
LTS	Bit	BOOL	0	2529407	Decimal
M	Bit	BOOL	0	161882111	Decimal
R	Word	WORD	0	32767	Decimal
SB	Bit	BOOL	0	9A61FFF	Hexadecimal
SD	Word	WORD	0	4095	Decimal
SM	Bit	BOOL	0	4095	Decimal
STC	Bit	BOOL	0	8993439	Decimal
STN	Word	WORD	0	8993439	Decimal
STS	Bit	BOOL	0	8993439	Decimal
SW	Word	WORD	0	9A61FF	Hexadecimal

Device name	Device type	Data type	Start address	End address	Address representation
TC	Bit	BOOL	0	8993439	Decimal
TN	Word	WORD	0	8993439	Decimal
TS	Bit	BOOL	0	8993439	Decimal
Un\G ²	Word	WORD	0	268435455	Decimal
U3En\G ³	Word	WORD	0	268435455	Decimal
U3En\HG ³	Word	WORD	0	268435455	Decimal
W	Word	WORD	0	9A61FF	Hexadecimal
ZR	Word	WORD	0	10027007	Decimal

*1 For a link direct device (Jn\), specify a network number (1 to 239) for 'n.'

*2 For a module access device (Un\G), specify the first two digits (0 to FF) of the start input/output number in three-digits representation for 'n.'

*3 For a CPU buffer memory access device (U3En\G or U3En\HG), specify the input/output number of the CPU module (0 to 3) for 'n.'

■ Rsafty

Device name	Device type	Data type	Start address	End address	Address representation
X	Bit	BOOL	0	2FFF	Hexadecimal
Y	Bit	BOOL	0	2FFF	Hexadecimal
B	Bit	BOOL	0	5A49FFF	Hexadecimal
CC	Bit	BOOL	0	5259711	Decimal
CN	Word	WORD	0	5259711	Decimal
CS	Bit	BOOL	0	5259711	Decimal
D	Word	WORD	0	5917183	Decimal
F	Bit	BOOL	0	32767	Decimal
Jn\B ¹	Bit	BOOL	0	9FFFF	Hexadecimal
Jn\SB ¹	Bit	BOOL	0	13FF	Hexadecimal
Jn\SW ¹	Word	WORD	0	13FF	Hexadecimal
Jn\W ¹	Word	WORD	0	27FFFF	Hexadecimal
Jn\X ¹	Bit	BOOL	0	27FFF	Hexadecimal
Jn\Y ¹	Bit	BOOL	0	27FFF	Hexadecimal
L	Bit	BOOL	0	32767	Decimal
LCC	Bit	BOOL	0	2784543	Decimal
LCN	Word	DWORD	0	2784543	Decimal
LCS	Bit	BOOL	0	2784543	Decimal
LSTC	Bit	BOOL	0	1479295	Decimal
LSTN	Word	DWORD	0	1479295	Decimal
LSTS	Bit	BOOL	0	1479295	Decimal
LTC	Bit	BOOL	0	1479295	Decimal
LTN	Word	DWORD	0	1479295	Decimal
LTS	Bit	BOOL	0	1479295	Decimal
M	Bit	BOOL	0	94674943	Decimal
R	Word	WORD	0	32767	Decimal
SAIB ²	Bit	BOOL	0	9BFFF	Hexadecimal
SAICC ²	Bit	BOOL	0	35487	Decimal
SAICN ²	Word	WORD	0	35487	Decimal
SAICS ²	Bit	BOOL	0	35487	Decimal
SAID ²	Word	WORD	0	39935	Decimal
SAIM ²	Bit	BOOL	0	638975	Decimal
SAISD ²	Word	WORD	0	4095	Decimal
SAISM ²	Bit	BOOL	0	4095	Decimal
SAISTC ²	Bit	BOOL	0	35487	Decimal
SAISTN ²	Word	WORD	0	35487	Decimal
SAISTS ²	Bit	BOOL	0	35487	Decimal

Device name	Device type	Data type	Start address	End address	Address representation
SA\TC ^{*2}	Bit	BOOL	0	35487	Decimal
SA\TN ^{*2}	Word	WORD	0	35487	Decimal
SA\TS ^{*2}	Bit	BOOL	0	35487	Decimal
SA\W ^{*2}	Word	WORD	0	9BFF	Hexadecimal
SA\X ^{*2}	Bit	BOOL	0	2FFF	Hexadecimal
SA\Y ^{*2}	Bit	BOOL	0	2FFF	Hexadecimal
SB	Bit	BOOL	0	5A49FFF	Hexadecimal
SD	Word	WORD	0	4095	Decimal
SM	Bit	BOOL	0	4095	Decimal
STC	Bit	BOOL	0	5259711	Decimal
STN	Word	WORD	0	5259711	Decimal
STS	Bit	BOOL	0	5259711	Decimal
SW	Word	WORD	0	5A49FF	Hexadecimal
TC	Bit	BOOL	0	5259711	Decimal
TN	Word	WORD	0	5259711	Decimal
TS	Bit	BOOL	0	5259711	Decimal
Un\G ^{*3}	Word	WORD	0	268435455	Decimal
U3En\G ^{*4}	Word	WORD	0	268435455	Decimal
U3En\HG ^{*4}	Word	WORD	0	268435455	Decimal
W	Word	WORD	0	5A49FF	Hexadecimal
ZR	Word	WORD	0	5832703	Decimal

*1 For a link direct device (Jn\), specify a network number (1 to 239) for 'n.'

*2 For a safety device, its value is read-only.

*3 For a module access device (Un\G), specify the first two digits (0 to FF) of the start input/output number in three-digits representation for 'n.'

*4 For a CPU buffer memory access device (U3En\G or U3En\HG), specify the input/output number of the CPU module (0 to 3) for 'n.'

■ FX5CPU

Device name	Device type	Data type	Start address	End address	Address representation
X	Bit	BOOL	0	1777	Octal
Y	Bit	BOOL	0	1777	Octal
B	Bit	BOOL	0	7FFF	Hexadecimal
CC	Bit	BOOL	0	1023	Decimal
CN	Word	WORD	0	1023	Decimal
CS	Bit	BOOL	0	1023	Decimal
D	Word	WORD	0	7999	Decimal
F	Bit	BOOL	0	32767	Decimal
L	Bit	BOOL	0	32767	Decimal
LCC	Bit	BOOL	0	1023	Decimal
LCS	Bit	BOOL	0	1023	Decimal
M	Bit	BOOL	0	32767	Decimal
R	Word	WORD	0	32767	Decimal
SB	Bit	BOOL	0	7FFF	Hexadecimal
SD	Word	WORD	0	11999	Decimal
SM	Bit	BOOL	0	9999	Decimal
STC	Bit	BOOL	0	1023	Decimal
STN	Word	WORD	0	1023	Decimal
STS	Bit	BOOL	0	1023	Decimal
SW	Word	WORD	0	7FFF	Hexadecimal
TC	Bit	BOOL	0	1023	Decimal
TN	Word	WORD	0	1023	Decimal
TS	Bit	BOOL	0	1023	Decimal
Un\G ^{*1}	Word	WORD	0	262143	Decimal
W	Word	WORD	0	7FFF	Hexadecimal

*1 For a module access device (Un\G), specify the first two digits (0 to FF) of the start input/output number in three-digits representation for 'n.'

■ QCPU

Device name	Device type	Data type	Start address	End address	Address representation
X	Bit	BOOL	0	1FFF	Hexadecimal
Y	Bit	BOOL	0	1FFF	Hexadecimal
B	Bit	BOOL	0	FFFF	Hexadecimal
CC	Bit	BOOL	0	32767	Decimal
CN	Bit	WORD	0	32767	Decimal
CS	Bit	BOOL	0	32767	Decimal
D	Word	WORD	0	4849663	Decimal
F	Bit	BOOL	0	2047	Decimal
Jn\B	Bit	BOOL	0	7FFF	Hexadecimal
Jn\SB	Bit	BOOL	0	1FF	Hexadecimal
Jn\SW	Word	WORD	0	1FF	Hexadecimal
Jn\W	Word	WORD	0	1FFFF	Hexadecimal
Jn\X	Bit	BOOL	0	3FFF	Hexadecimal
Jn\Y	Bit	BOOL	0	3FFF	Hexadecimal
L	Bit	BOOL	0	32767	Decimal
M	Bit	BOOL	0	61439	Decimal
R	Word	WORD	0	4849663	Decimal
SB	Bit	BOOL	0	7FFF	Hexadecimal
SD	Word	WORD	0	2047	Decimal
SM	Bit	BOOL	0	2047	Decimal
STC	Bit	BOOL	0	32767	Decimal
STN	Word	WORD	0	32767	Decimal
STS	Bit	BOOL	0	32767	Decimal
SW	Word	WORD	0	7FFF	Hexadecimal
TC	Bit	BOOL	0	32767	Decimal
TN	Word	WORD	0	32767	Decimal
TS	Bit	BOOL	0	32767	Decimal
Un\G	Word	WORD	0	65535	Decimal
U3En\G	Word	WORD	0	24335	Decimal
W	Word	WORD	0	4AEBFF	Hexadecimal
ZR	Word	WORD	0	4849663	Decimal

■ LCPU

Device name	Device type	Data type	Start address	End address	Address representation
X	Bit	BOOL	0	1FFF	Hexadecimal
Y	Bit	BOOL	0	1FFF	Hexadecimal
B	Bit	BOOL	0	FFFF	Hexadecimal
CC	Bit	BOOL	0	32767	Decimal
CN	Word	WORD	0	32767	Decimal
CS	Bit	BOOL	0	32767	Decimal
D	Word	WORD	0	421887	Decimal
F	Bit	BOOL	0	32767	Decimal
Jn\SB	Bit	BOOL	0	1FF	Hexadecimal
Jn\SW	Word	WORD	0	1FF	Hexadecimal
Jn\W	Word	WORD	0	3FFF	Hexadecimal
Jn\X	Bit	BOOL	0	3FFF	Hexadecimal
Jn\Y	Bit	BOOL	0	3FFF	Hexadecimal
L	Bit	BOOL	0	32767	Decimal
M	Bit	BOOL	0	61439	Decimal
SB	Bit	BOOL	0	7FFF	Hexadecimal
SD	Word	WORD	0	2047	Decimal
SM	Bit	BOOL	0	2047	Decimal
STC	Bit	BOOL	0	32767	Decimal
STN	Word	WORD	0	32767	Decimal
STS	Bit	BOOL	0	32767	Decimal
SW	Word	WORD	0	6FFFF	Hexadecimal
TC	Bit	BOOL	0	32767	Decimal
TN	Word	WORD	0	32767	Decimal
TS	Bit	BOOL	0	32767	Decimal
Un\G	Word	WORD	0	65535	Decimal
W	Word	WORD	0	66FFF	Hexadecimal
ZR	Word	WORD	0	393215	Decimal

PLC data writing block

The PLC data writing block writes a user-specified fixed value and the output data of the previous block, which is stored in a data stream, to the device of a programmable controller.

By using this block, a programmable controller can get a feedback on the result of task execution (such as the inspection result) from this product.



This block can also be used to confirm that a task is executed in a fixed cycle. (Programming a programmable controller is required.)

The following shows the setting example of a task flow and the programming example of a programmable controller to confirm that a task is executed in a fixed cycle. Use devices and time described in the example as a reference. Make sure to verify the operation before operating a system.

Example

Controlling the task processing timer (T0: 10 seconds) via the task processing END notification (M0) and detecting a failure to execute a task in a fixed cycle using the timeout notification (M1)

- Task flow setting
 - Add 'PLC data writing' to the beginning of a task flow, and turn OFF (clear) the task processing END notification.
 - Add 'PLC data writing' to the end of the task flow, and turn ON the task processing END notification.
- If a task flow branches, add the same processing to each branch.
- Programming of a programmable controller
 - Stop (reset) the task processing timer when the task processing END notification turns OFF (↓).
 - Start the task processing timer when the task processing END notification turns ON (↑).
 - Turn ON the timeout notification when the task processing timer times out.

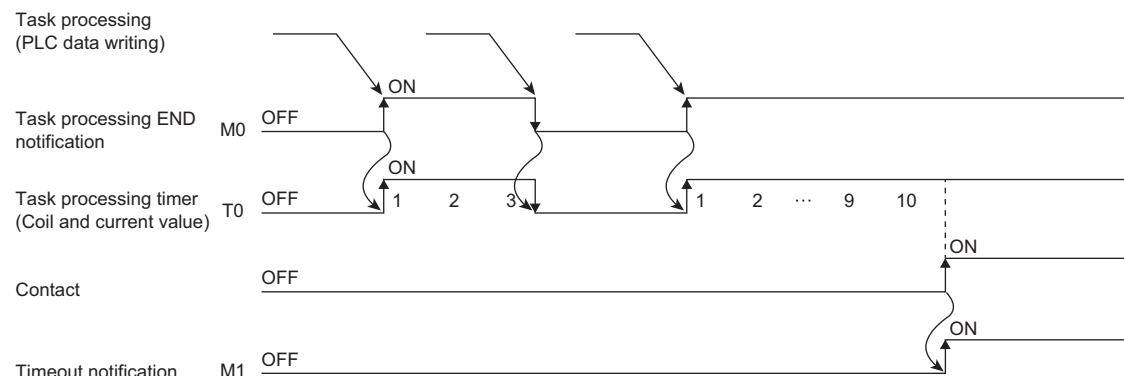

Input/output specifications

The following shows the input and output specifications of this block.

Input

- When using the output data of the previous block

Data name	Data type	Description
Block output data	<ul style="list-style-type: none"> • Image • Numerical value • Character string 	Output data of the previous block

- Other than above

None

Output

None

PLC data writing screen (programmable controller connection setting)

The following shows the screen for setting the information of a programmable controller to be connected.

Window

The screenshot displays the 'PLC data writing' window with the following sections and controls:

- General setting:** CPU series (dropdown, 'Please input a value.'), CPU type (dropdown, 'Please input a value.'), and an 'OPERATION DETAIL SETTING' button.
- PC-side interface setting:** PC-side interface (dropdown), IP address (text input, 'Please input a value.'), Network number (input: 1), and Station number (input: 1).
- Machine-side interface setting:** Machine-side interface (dropdown), Protocol type (dropdown: TCP), IP address (text input), Network number (input: 1), and Station number (input: 1).
- COMMUNICATION TEST** button.
- Navigation buttons: BACK, NEXT, OK, CANCEL.

Displayed items

Item	Description	
General setting	CPU series	Select CPU series to be connected.
	CPU type	Select a CPU type to be connected.
	[OPERATION DETAIL SETTING] button	Click this to configure the detailed settings for communication with the CPU. (Page 141 Operation detail setting screen)
		Click this to display up to 10 programmable controller connection settings*1 which have been set for the project in the past. (Page 141 Connection destination setting history screen)
PC-side interface setting	PC-side interface	Select the interface of a personal computer to be connected.
	IP address	Specify the IP address of a personal computer side interface to be connected.
	Network number	Specify the network number of a personal computer side interface to be connected.
	Station number	Specify the station number of a personal computer side interface to be connected.
Machine-side interface setting	Machine-side interface	Select a machine side interface type.
	Protocol type	Select a protocol type.
	IP address	Specify the IP address of a CPU or machine side interface to be connected.
	Network number	Specify the network number of a CPU to be connected.
	Station number	Specify the station number of a CPU to be connected.
[COMMUNICATION TEST] button	Click this to perform a communication test with a programmable controller.	

*1 If the number of pieces of past information exceeds 10, the information will be deleted in chronological order.

■ Operation detail setting screen

Window

Operation detail setting

Timeout time s

Number of retries

Displayed items

Item	Description
Timeout time	Set a communication timeout time. (1 to 90 [s])
Number of retries	Set the number of retries (0 to 9) due to communication failure.

■ Connection destination setting history screen

Window

Connection destination setting history

Please select the programmable controller connection destination setting to be used. ?

(1)

Task_001	
R08CPU	2023/09/21 18:11:50.914

Displayed items

Item	Description
(1) History list	Programmable controller connection settings which have been set in the past are displayed.

PLC data writing screen (writing setting)

The following shows the screen for setting a write target.

Window

Displayed items

Item	Description
+ (Add)	Click this to create the setting of a device to be written. (Up to 20 settings)
☒ (Delete)	Click this to delete the selected setting.
↑/↓	Click either of these to change the order of the selecting setting.
Device	Set the type and device number of a write target device.
Fixed value type/block name	Select a fixed value type or block to be written.
Fixed value (Character string) ^{*1}	Set a character string to be written. <ul style="list-style-type: none"> • When the data type is STRING: 1 to 32 characters. • When the data type is WSTRING: 1 to 16 characters • When the data type is BOOL: Set a character string that represents BOOL. For the output contents, refer to the following: (📖 Page 143 Processing block execution (executing))
Fixed value (Numerical value) ^{*2}	Set a numerical value to be written. The value range differs depending on the data type. For details, refer to the following: (📖 Page 143 Processing block execution (executing))
Output data ^{*3}	Select data to be written.
Data type	Select a data type.
Number of characters	Specify the number of characters to be written. This must be specified when selecting "STRING" or "WSTRING" for a data type. <ul style="list-style-type: none"> • STRING: 1 to 32 • WSTRING: 1 to 16
Comment	Enter a comment (0 to 64 characters).

*1 Displayed when selecting "Fixed value(Character string)" for "Fixed value type/block name."

*2 Displayed when selecting "Fixed value (Numerical value)" for "Fixed value type/block name."

*3 Displayed when selecting a block for "Fixed value type/block name."

Operational specifications (while editing a task)

This block sets a write target and the connection destination of a programmable controller.

Additionally, it can perform a communication test with a programmable controller.

Operational specifications (while a task is running)

This block writes the output data of the previous block and a user-specified fixed value to devices of a programmable controller.

■ Behavior when a response timeout error occurs

Refer to the following:

☞ Page 131 Behavior when a response timeout error occurs

■ Start processing (preparing)

The block connects to a programmable controller set in the programmable controller connection setting. (If the connection between the block and a programmable controller is already established, the connection processing is not performed.)

■ Processing block execution (executing)

The block acquires data from a data stream, converts the data into the specified data type, and then writes it to a device.

- PLC data writing

When data (a fixed value or the output data of a block) to be written does not match with the range of the specified data type, the block writes the data according to the specifications of the specified data type. If a write data value is equal to or more than the maximum value of the specified data type, it will be rounded off to the maximum value of the specified data type. On the other hand, if a write data value is equal to or less than the minimum value of the specified data type, it will be rounded up to the minimum value of the specified data type.

(An incorrect data type error occurs when the data type is 'REAL' or 'LREAL' and data to be written is '+Inf,' '-Inf,' or 'NaN'.)

Specified data type	Description	Conversion example
BOOL	<ul style="list-style-type: none"> ■Data to be written is a character string that represents a BOOL value *1 • 'True': '1' is output. • 'False': '0' is output. ■Data to be written is '0' • '0' is output. ■Data to be written is other than described above • '1' is output. 	<ul style="list-style-type: none"> • When data to be written is '0.123,' '1' will be written. • When data to be written is 'AB,' '1' will be written.
WORD, INT, UINT, DWORD, DINT, UDINT	Data to be written is converted into the specified data type, then output. (The value after the decimal point is rounded off.)	When data to be written is '12.34,' '12' will be written.
REAL, LREAL	When data to be written is an integer, it will be output as real number data.	When data to be written is '12,' '12.0' will be written.
STRING, WSTRING	Data to be written is not converted.	—

*1 "True" or "False" (Characters are not case-sensitive.)

The following table shows the value range of data types.

Data type		Value range
BOOL	Binary (0 or 1)	0, 1
WORD	Unsigned 16-bit integer	0 to 65535
INT	Signed 16-bit integer	-32768 to 32767
UINT	Unsigned 16-bit integer	0 to 65535
DWORD	Unsigned 32-bit integer	0 to 4294967295
DINT	Signed 32-bit integer	-2147483648 to 2147483647
UDINT	Unsigned 32-bit integer	0 to 4294967295
REAL	32-bit real number	-3.402823E+38 to 3.402823E+38
LREAL	64-bit real number	-1.79769313486231E+308 to 1.79769313486231E+308
STRING	Character string (ASCII)	—
WSTRING	Character string (Unicode®(UTF-16))	—

The set devices are sorted in order from the top and written in a batch. The maximum number of data points that can be written in a batch depends on the type of a programmable controller and a data writing route. For the maximum number of data points, refer to the manual for a programmable controller and a network used.

Exceeding the maximum number of data points may cause data inconsistency because the time of writing data is extended across scan intervals.

■ Stop processing (transitioning to stop)

The start processing (preparing) is canceled when it is in progress. Additionally, the connection with a programmable controller is disconnected.

When the processing block execution is in progress, the stop processing is performed after the processing block execution is completed. Additionally the connection with a programmable controller is disconnected.

Accessible devices

Refer to the following:

 Page 133 Accessible devices

Imaging block

The imaging block instructs a camera to capture an image and acquires the image.

Camera parameters can be set while checking the actually captured image. Parameters that have been set on the camera side are applied for parameters that have not been set.

When a task is running, this block connects to a camera and writes parameters to it at the start of the task. The block also maintains a connection with the camera.

Point

It is recommended to configure the imaging setting after connecting a camera to the learning machine or inspection machine in advance.

11

Precautions

- Cameras that have the same IP address within a task are operated by sharing the same parameters.
- Multiple connections to a camera are not available. Therefore, if a task uses the camera that is already used in another running task, the task cannot be started.

Input/output specifications

The following shows the input and output specifications of this block.

■ Input

None

■ Output

Data name	Data type	Description
Captured image	Image	Image data captured with a camera

Imaging screen (camera connection destination setting)

The following shows the screen for setting the information of a camera to be connected.

Window

Displayed items

Item		Description
Specify with the IP address	IP address	Select this to specify a camera with an IP address.
		Click this to display up to 10 IP addresses ^{*1} which have been set for the project in the past.
Specify with the connected camera	Camera model name	Select a camera to be connected. Cameras being connected to this product are displayed in a list (up to eight cameras). (Page 150 Acquiring camera information) <ul style="list-style-type: none"> Serial number: The serial number of the selected camera is displayed. IP address to be set: Enter the IP address to be set for the selected camera. ^{*2}
		Click this to display up to 10 cameras ^{*1} which have been set for the project in the past.
	(The information of the connected camera will be reacquired.)	Click this to re-acquire the information of a camera being connected.
[OPERATION DETAIL SETTING] button		Click this to configure the detailed settings for communication with the camera. (Page 147 Operation detail setting screen)

*1 If the number of pieces of past information exceeds 10, the information will be deleted in chronological order.

*2 When selecting a camera, the IP address set for the camera is displayed.

■ Operation detail setting screen

Window

Operation detail setting

Timeout time s

Number of retries

11

Displayed items

Item	Description
Timeout time	Set a communication timeout time. (1 to 90 [s])
Number of retries	Set the number of retries (0 to 9) due to communication failure.

Imaging screen (parameter setting)

The following shows the screen for setting parameters.

Window

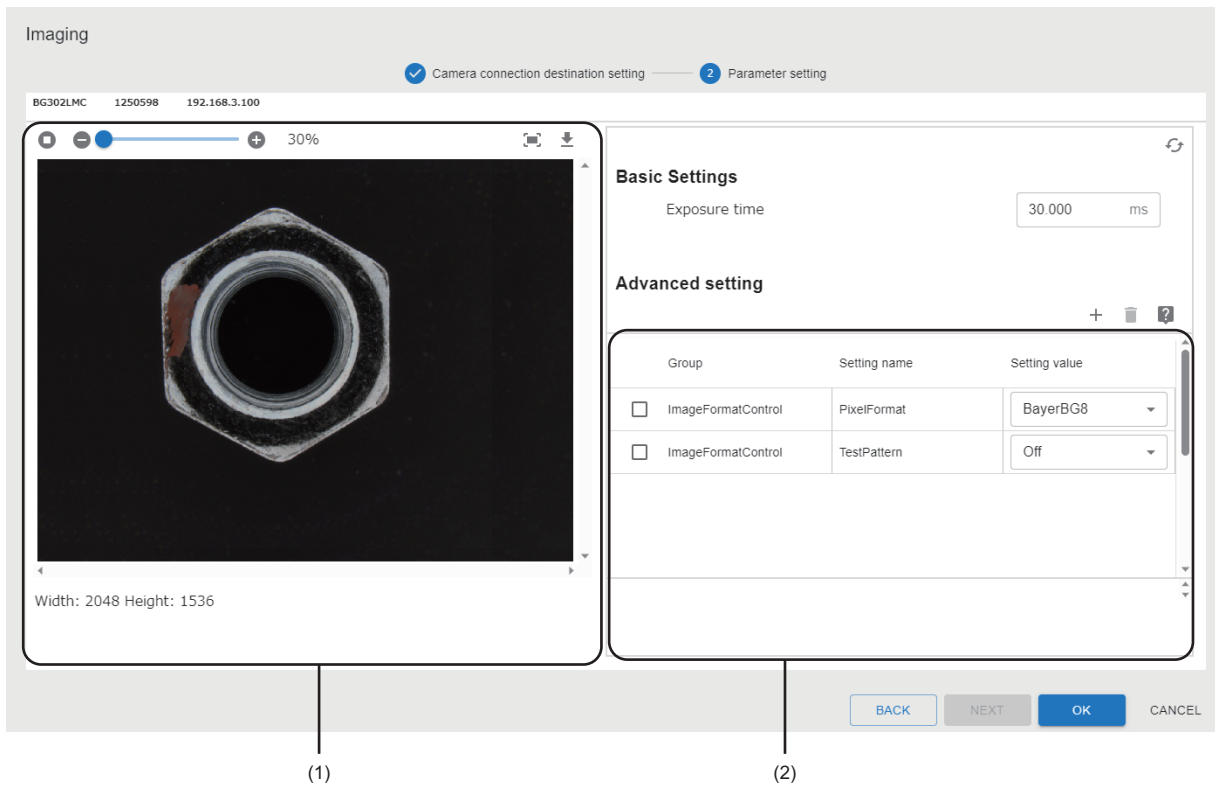

Displayed items

Item		Description
(1) Captured image information display area	(Imaging start)/(Imaging stop)	Click either of these to start or stop capturing images.*1
	(Shrink)/(Enlarge)	Click either of these to enlarge or reduce the size of the displayed image (in units of 10 percent). The image size can also be enlarged or reduced with a slider.
	(Fit display)	Click this to display an image which is resized to fit within the preview image display area.
	(Download)	Click this to download the displayed image to a personal computer.*2
	Width	The width of a preview image is displayed.
	Height	The height of a preview image is displayed.
(Update)*3		Click this to apply the settings of parameters to a camera.
Basic Settings	Exposure time	Set an exposure time.
Advanced setting	(Add camera parameter)	Click this to add camera parameters. (Page 149 Camera parameter selection screen)
	(Delete camera parameter)	Click this to delete the selected camera parameter.
	(2) Camera parameter setting area	Add a parameter to be used by clicking (Add camera parameter) to set the parameter.

*1 The settings of parameters are applied to a camera at the start of image capture.

*2 If a saving destination path exceeds the maximum number of characters, any of the following operations will be performed:

- The image is saved to the default download destination set on the web browser.
- Download fails.

*3 Cannot be clicked when image capture is stopped.

■ Camera parameter selection screen

Select parameters to be used. The parameters to be displayed differ depending on a camera being connected.

For details on parameter settings, refer to the following:

📖 Page 150 Parameter settings

Window

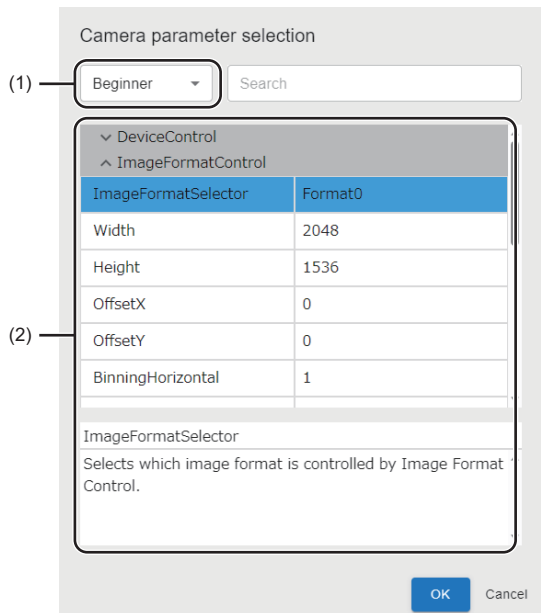

Displayed items

Item	Description
(1) User level selection	Select a parameter level to be displayed.
(2) Parameter display area	Parameters that can be set are displayed according to the selected user level.*1

*1 Parameters are not displayed if there are no parameters that can be displayed.

Precautions

Some parameters may be read-only depending on a camera to be used. Read-only parameters cannot be added to the advanced setting.

Operational specifications (while editing a task)

This block configures the camera connection destination setting and parameter setting.

■ Acquiring camera information

The information of a camera being connected is acquired. (Up to eight cameras)

When eight or more cameras are connected, some of the cameras may not be displayed in the imaging screen.

Point

Cameras being connected are listed in the order in which this product recognizes the connection of the cameras. Therefore, when re-displaying the list of cameras being connected, the display order may be changed.

Up to 10 camera connection destination settings set in the project can be retained as a history. If the number of settings exceeds the maximum number, the setting information will be deleted in chronological order.

■ Parameter settings

By connecting to a camera, the environment of capturing images and parameters can be adjusted while checking the actually captured images. There are two types of camera parameters: "Basic Settings" and "Advanced setting."

Item	Description
Basic Settings	Parameters that are frequently used among camera parameters can be set. This setting can be configured even when a camera is not connected.
Advanced setting	The advanced setting can be configured by acquiring a list of settable parameters from the connected camera.*1 Select parameters to be used by clicking  (Add camera parameter) because no advanced setting parameters are set in the default status. The setting can be configured only when a camera is connected. The camera is connected when the imaging screen (parameter setting) is displayed.

*1 Parameters that can be set differ depending on a camera to be connected. Applying parameters for which a camera does not support causes an error when writing parameter to the camera. For settable parameters, refer to the manual of a camera used.

For details on external devices for which operation has been confirmed, refer to the following technical bulletin:

 Applicable Industrial Cameras for MELSOFT VIXIO (FA-A-0419)

Point

It is recommended to set parameters required for image capture in the advanced setting even if they have already been set on the camera side.

Depending on the camera to be used, some parameters set on the camera side may be reset when the power of the camera is turned OFF and ON. This block overwrites only the parameters set in the imaging block to parameters being set on the camera side. Therefore, without setting the required parameters in the advanced setting, the camera behavior may be changed from when a task was started if parameters on the camera side are reset.

Operational specifications (while a task is running)

The block instructs a camera to capture an image according to parameter settings of the camera and acquires the image data. A camera is connected when a task in which the imaging block is placed starts running (preparing). The camera is disconnected when a task stops running (transitioning to stop).

■ Behavior when a response timeout error occurs

If an abnormal response (due to disconnection or communication timeout) is received from a connection destination device after a communication request is sent, the request is retried and a warning event is registered. An error event is registered if the request is retried up to the set number of times but an abnormal response is received after the last retry is attempted. (Once communication processing is successful, the number of retries is reset when the processing is successful.)

Ex.

The following figure shows the timing that an error event is registered when the number of retries is set to two.

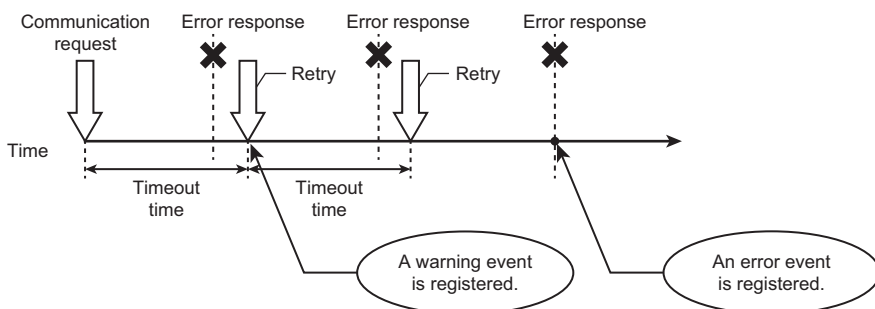

■ Start processing (preparing)

The block secures a memory area, connects to a camera, and updates camera parameters.

Precautions

When sharing a camera among multiple imaging blocks in a task, parameters set in each block are overwritten by parameters executed later.

Ex.

If imaging blocks that are set with the following parameters are run in the order of A, B, and C, the camera works with the camera parameters of Width = 1,500 and Height = 1,300.

Imaging block A: Width = 1,000

Imaging block B: Width = 1,500 and Height = 1,000

Imaging block C: Height = 1,300

■ Processing block execution (executing)

The block captures images with a camera, acquires the captured images, and outputs the images to a data stream.

If a connection to a camera fails, the block attempts to reconnect to the camera.

Precautions

When a camera is reconnected, images are captured after camera parameters are updated. The imaging block overwrites only the parameters set in the block to parameters on the camera side, which are set at the time when the camera is reconnected. Therefore, the camera behavior may be changed from when a task was started. For example, the camera behavior may be changed when parameters set on the camera side are overwritten after the parameters are reset because the power of the camera is turned OFF and ON while the task is running.

■ Stop processing (transitioning to stop)

When the processing block execution is in progress, the stop processing is performed after the processing block execution is completed.

When the block is in other statuses, the connection with a camera is disconnected and the memory is released.

Image import block

The image import block imports an image file from a specified folder.

This block can import an image file captured by a camera, which is not controlled by this product. The block can be used in the following cases:

- Using an existing camera
- Controlling a camera in detail
- Using a camera which is not supported by this product

Not only the folder of the learning machine or inspection machine where a task is running, but also the folder of a file server can be specified as an import source folder.

If there is no image file in the import source folder, the block will be in the wait state and checks the folder in the specified monitoring cycle until it imports an image file.

Input/output specifications

The following shows the input and output specifications of this block.

■ Input

None

■ Output

Data name	Data type	Description
Import image	Image	Imported image data

Image import screen

The following shows the screen for setting the import source of an image file.

Window

11

Displayed items

Item	Description
Import source	Specify the image import source folder with an absolute path.
	Click this to display up to 10 import source folders ^{*1} which have been set for the project in the past.
[COMMUNICATION TEST] button	Click this to perform a communication test with an import source folder.
Delete imported file	<ul style="list-style-type: none"> • Delete: To delete the imported file from an import source folder • Not delete (Move to the saving folder): To create the save folder (\$savi_imported\$) in the import source folder and move the imported file to the folder. (By moving the imported file to the save folder, importing multiple images can be prevented.)
Keyword (Partial match)	Set the keyword (0 to 64 characters) of the name of an image file to be imported. ^{*2}
Monitoring cycle	Set the cycle (100 to 10,000 [ms]) for monitoring an import source folder.

*1 If the number of pieces of past information exceeds 10, the information will be deleted in chronological order.

*2 Characters are case-sensitive.

Operational specifications (while editing a task)

This block sets the import source of an image file.

Additionally, it can perform a communication test with an import source folder.

Operational specifications (while a task is running)

This block imports an image file from the import source at each execution of this block according to the image import setting. If there is no image file to be imported, the block checks the import source folder in the monitoring cycle until it imports an image file.

Point

The following operations are performed by a Windows logon user on the accessing learning or inspection machine: performing import processing of this block, moving or deleting a file, and performing a communication test.

■ Start processing (preparing)

The block secures a memory area and performs a communication test with an import source folder. If any of these fails, the block stops a task.

■ Processing block execution (executing)

The block imports an image file by connecting to an import source folder. After importing the image file, the block deletes or moves the file to the save folder according to the setting of "Delete imported file."

If importing an image and moving or deleting the imported file fail, the behavior of this block is as follows:

Item	Description
Importing an image file fails.	If importing the image file of an import source folder fails, the file will be skipped, and the next image file will be imported. The skipped file will be imported when the import source folder is connected again.
There is no image file to be imported.	The image file is imported again after the cycle time set in "Monitoring cycle" elapses. (This process is repeated until an image file is successfully imported.)
Deleting and moving an image file according to the setting of "Delete imported file" fails.	A target image file is registered in the exclusion list and the file is excluded from the import. The exclusion list is cleared when a task is stopped. Image files that were in the list are imported when a task is started next time.

• Searching for image files

From image files saved in the folder specified in "Import source," the block searches for files that satisfy the following conditions: The file has the extension of jpg, jpeg, png, or bmp and the file name (including an extension) contains character strings specified in "Keyword (Partial match)." (If no keyword is specified in "Keyword (Partial match)," all files will be searched.)

• Importing an image file

The block imports an image file that has the oldest creation date and time. If several files have the same creation date and time, a file is imported in ascending order of their names.

If there is no image file to be imported, a file search is performed in the specified monitoring cycle and a file is imported when an available file is found.

• Deleting an image file

The block deletes image files imported from an import source folder when selecting "Delete" for "Delete imported file."

• Moving an image file

The block creates the save folder (\$aiivi_imported\$) in an import source folder and moves the imported file to the folder when "Not delete (Move to the saving folder)" is selected for "Delete imported file."

If a file with the same name already exists in the save folder, a four-digit number with zero padding is added to the end of the file name. The initial value '_0000' is added to the end of the file name and is incremented so that the name is not duplicated with other files.*¹

*¹ Even if the number exceeds 10,000, the number is incremented (such as 10,001 and 10,002) without changing the number of digits.

■ Stop processing (transitioning to stop)

The start processing (preparing) is canceled when it is in progress.

When the processing block execution is in progress, the stop processing is executed as follows:

- Searching for image files: The searching operation is canceled.
- Importing, deleting, or moving an image file: The stop processing is performed after the processing block execution is completed.

11.3 AI Model Inspection Category

This section explains processing blocks in the AI model inspection category. These blocks execute the processing of an AI model.

AI model execution blocks

AI model execution blocks specify an AI model generated in the learning machine and perform inference for input images. It also outputs the judgment result to the next block in numerical values or character strings.

The blocks are divided into blocks for each AI engine. Use a block for an AI engine type used for an AI model.

Block	Input	Output
Anomaly detection	Image	<ul style="list-style-type: none">• Judgment result (Numerical value)• Judgment result (Character string)• Heat map image• Error level
Defective point detection		<ul style="list-style-type: none">• Judgment result (Numerical value)• Judgment result (Character string)• Heat map image• Error location (maximum)• Error location (total)

Point

When using the defective point detection block, GPU is required.

Approximately 2.4 GB of GPU memory is occupied for each task which uses the defective point detection block.

Input/output specifications

The following shows the input and output specifications of this block.

■ Input

Data name	Data type	Description
Captured image or import image	Image	Either of the following images is acquired from data which is output from the previous block. <ul style="list-style-type: none">• An image captured using the imaging block• An image imported using the image import block

■ Output

- AI model execution (common for anomaly detection and defective point detection)

Data name	Data type	Description
Judgment result (Numerical value)	Numerical value	A numerical value corresponding to the judgment result <ul style="list-style-type: none"> • 0: Non-defective product • 1: Defective product • 900: No judgment result
Judgment result (Character)	Character string	A character string corresponding to the judgment result <ul style="list-style-type: none"> • Pass: Non-defective product • Fail: Defective product • None: No judgment result
Heat map image ^{*1}	Image	An image where the output map ^{*2} of an AI model is overlaid on an input image <ul style="list-style-type: none"> • Maximum size: 640 [px] × 480 [px] A heat map image will not be output if the judgment result is other than a non-defective product or defective product.

*1 Cannot be used for the input data of the AI model execution block.

*2 During inspection, an AI model creates an output map which indicates the error location of an input image.

An output map is an image where the size of an error in the whole area of an input image is depicted by color.

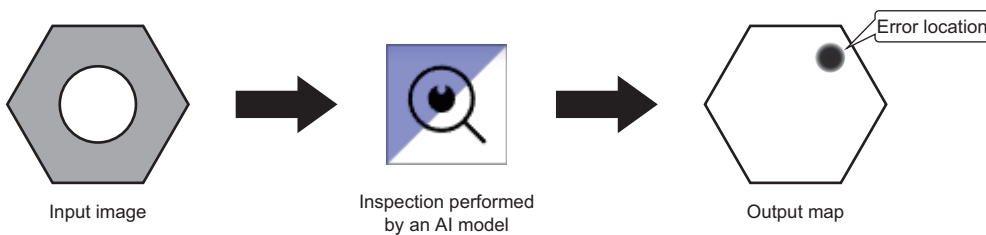

- Anomaly detection

Data name	Data type	Description
Error level	Numerical value	An error level calculated from the output map of an AI model <ul style="list-style-type: none"> • 0.00 to 255.00 (Rounded up to two decimal places) If the judgment result is other than 'non-defective product' or 'defective product,' the value will be '0.'

- Defective point detection

Data name	Data type	Description
Error location (maximum)	Numerical value	The maximum area of an error location calculated from the output map <ul style="list-style-type: none"> • 0 to the area of an input image If the judgment result is other than 'non-defective product' or 'defective product,' the value will be '0.'
Error location (total)		The total area of error locations calculated from the output map <ul style="list-style-type: none"> • 0 to the area of an input image If the judgment result is other than 'non-defective product' or 'defective product,' the value will be '0.'

Point

If the judgment result is 'no judgment result,' the value of 'Error level,' 'Error location (maximum),' and 'Error location (total)' will be '0.' When using the value of 'Error level,' 'Error location (maximum),' and 'Error location (total)' in the next processing block, use them together with the value of the judgment result so that the result can be distinguished from the normal judgment result which is output when there is no error location detected.

AI model execution screen (input block setting)

The following shows the screen for setting an input block.

Window

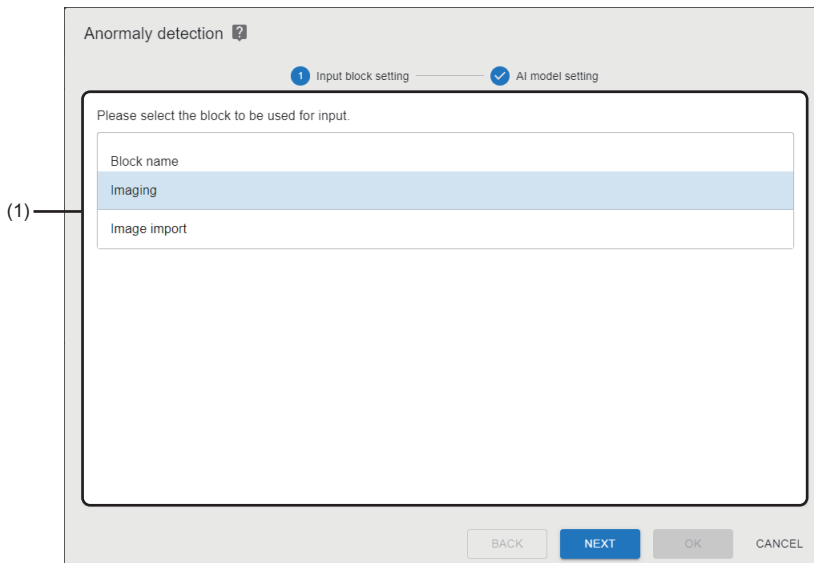

Displayed items

Item	Description
(1) Input block list	Select a block to be used for an input.

AI model execution screen (AI model setting)

The following shows the screen for selecting an AI model to be executed.

Window

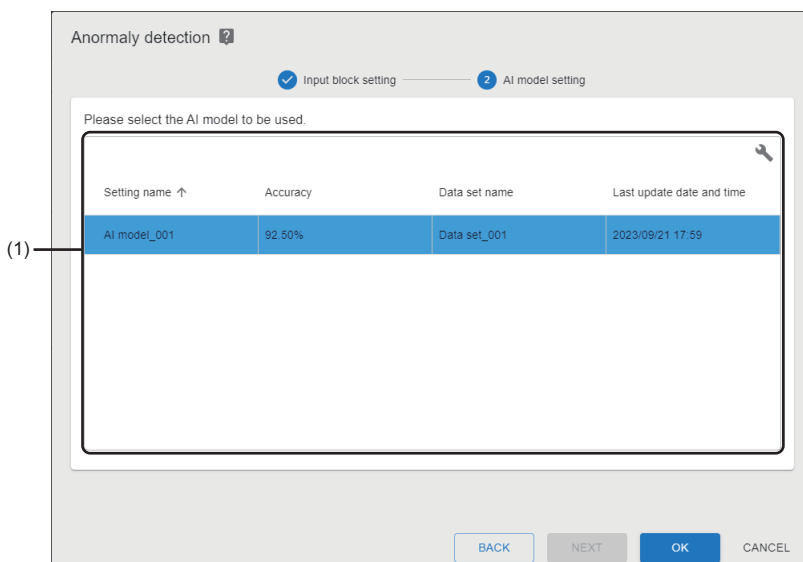

Displayed items

Item	Description
(1) AI model list	Select an AI model to be used.

Operational specifications (while editing a task)

This block selects an input block to be used and an AI model.

Operational specifications (while a task is running)

This block performs preprocessing and inference for the input image.

Precautions

To use the defective point detection block, approximately 2.4 GB of GPU memory must be secured per task, which uses the block.

■ Start processing (preparing)

The following start processing is executed.

Processing	Description
AI model	The block executes the start processing of an AI model in the following order: <ol style="list-style-type: none"> ① Checking an AI model ② Checking a GPU (only for defective point detection) ③ Securing resources for a CPU and GPU ④ Reading the AI model

■ Processing block execution (executing)

The block performs the inference of an AI model for an input image and outputs the result.

No.	Processing	Description
1	Acquiring input data	Image data that is input in a block is acquired.
2	Executing preprocessing	Preprocessing is executed for the acquired image data.
3	Performing inference	The inference of an AI model is performed by inputting image data to an AI model.
4	Processing the inference result	The inference result is output.

Processing of the inference result for each AI model is as follows:

- Common for AI models

Inspection result	Method for acquiring the inspection result
Acquiring the judgment result	The judgment result for a threshold set in the AI model validation screen is as follows: <ul style="list-style-type: none"> • Non-defective product: Less than the threshold • Defective product: Equal to or more than the threshold
Generating a heat map image	An image where the output map of an AI model is overlaid on an input image is created <ul style="list-style-type: none"> • Heat map color: A heat map color displayed in the AI model validation screen. • Aspect ratio: The size of input image data • Maximum size: 640 [px] × 480 [px]^{*1}

*1 When the input image size exceeds the maximum size, reduce the image size to fit into the maximum size with the aspect ratio being maintained.

- Anomaly detection

Inspection result	Method for acquiring the inspection result
Calculating an error level	The maximum value of an error level in an output map

- Defective point detection

Inspection result	Method for acquiring the inspection result
Calculating the error location (maximum)	The number of pixels of the blob that has the largest area among blobs detected by blob detection for the output map
Calculating the error location (total)	The total number of pixels determined as error in an output map

■ Stop processing (transitioning to stop)

When the processing block execution is in progress, the stop processing is performed after the processing block execution is completed. Additionally, the block releases an AI model.

11.4 Utility Category

This section explains processing blocks in the utility category. These blocks execute processing to control the behavior of tasks.

Conditional branch block

The conditional branch block initially determines whether or not the output data of the previous block matches with a condition created for the output data. The block branches a task flow by joining the judgment results to each other and determining these results using the condition convergence method (AND or OR).

Using this block allows multiple inspection results to be determined comprehensively and a task flow to be branched. Therefore, feedback corresponding to the inspection results can be provided.

Input/output specifications

The following shows the input and output specifications of this block.

Input

The block outputs blocks whose data types are either of the following types:

- Numerical value
- Character string

Output

None

Conditional branch screen

The following shows the screen for setting the conditional branch of a task flow.

Window

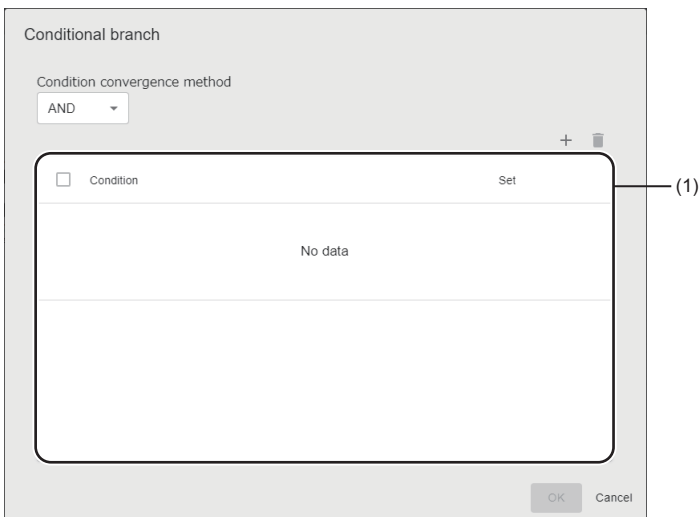

Displayed items

Item	Description	
Condition convergence method	Select a method for combining conditions.	
+ (Add)	Click this to add a condition. (Maximum eight conditions)	
- (Delete)	Click this to delete the selected condition.	
(1) Condition list	Condition	Created conditions are displayed in a list.
	Set	Set a condition. (Page 160 Condition settings)

■ Condition settings

The following shows the screen for setting a method for determining the output data of the previous block.

Window

Condition setting

Judgment target: Anomaly detection_Error le...
Operator: <
Comparison target type: Fixed value
Comparison target value:
Please input a value.

OK Cancel

Displayed items

Item	Description
Judgment target	Select a judgment target from the output data of the previous block.
Operator	Select a comparison operator. The available operators differ depending on the type of data selected in "Judgment target."
Comparison target type	Select a comparison target type.
Comparison target ^{*1}	Select a comparison target.
Comparison target value ^{*2}	Select or specify a comparison target value.
Comparison target character ^{*3}	Select or specify comparison target characters (1 to 32 characters ^{*4}).

*1 Displayed when selecting "Block" for "Comparison target type."

*2 Displayed when the data type of "Judgment target" is a numerical value and when selecting "Fixed value" for "Comparison target type."

*3 Displayed when the data type of "Judgment target" is a character string and when selecting "Fixed value" for "Comparison target type."

*4 When the data type of "Judgment target" is WSTRING, 1 to 16 characters can be specified.

Point

A real number is output when outputting a numerical value at the AI model execution. Therefore, it is recommended to use an inequality sign (<, ≤, ≥, or >) for an operator.

Precautions

When a single-precision real number is compared with a double-precision real number, conditions may be satisfied or not satisfied unintentionally due to the differences in accuracy.

Operational specifications (while editing a task)

The block sets the conditional branch of a task flow.

Operational specifications (while a task is running)

The block branches a task flow according to the result determined by condition settings and a condition convergence method.

■ Start processing (preparing)

None

■ Processing block execution (executing)

Processing is executed in the following order:

1. Determining conditions

All created conditions are determined.

2. Joining conditions

The judgment result of each condition is joined to each other and the results are determined by a condition convergence method.

- AND: To check if all conditions are true in the determination result
- OR: To check if one or more conditions is (are) true in the determination result

3. Branching a task flow

A task flow is branched according to the result of determination by the condition convergence method.

- When the judgment result is true, a block which is connected to the contact (upper side) of 'True' is executed.
- When the judgment result is false, a block which is connected to the contact (lower side) of 'False' is executed.

■ Stop processing (transitioning to stop)

When the processing block execution is in progress, the stop processing is performed after the processing block execution is completed.

Monitor input waiting block

The monitor input waiting block pauses the running of a task flow.

This block is used for controlling the execution timing of processing blocks manually, such as when running a task for a trial or when capturing images for learning by using a task.

A task flow can be restarted manually from the task monitor screen. ( Page 167 Task Monitor Screen)

Input/output specifications

The following shows the input and output specifications of this block.

■ Input

None

■ Output

None

Operational specifications (while editing a task)

None

Operational specifications (while a task is running)

The block pauses a task flow.

■ Start processing (preparing)

None

■ Processing block execution (executing)

The block continues to pause the task flow from when the block is executed.

A task flow is restarted by clicking "Monitor input waiting" in the task monitor screen.

■ Stop processing (transitioning to stop)

When the processing block execution is in progress, the processing of this block is canceled and the operation is terminated.

12 TASK OPERATION

This chapter explains the operation of created tasks.

12.1 Operation Procedure for a Task

This section explains the procedure for operating a task.

1. Start a task. (☞ Page 163 Starting a task)
2. Check a task status. (☞ Page 164 Checking a task status)
3. Check an inspection result history. (☞ Page 165 Checking an inspection result history)

12

Starting a task

The following shows the procedure for starting a task.

Operating procedure

Select a target task in the task management screen, and click the [Start] button. (☞ Page 118 Task Management Screen)
Once the task is started, task processing is executed repeatedly until it stops.

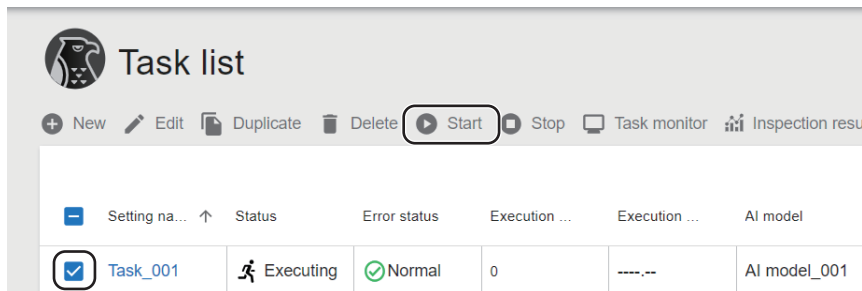

Point

A task can be run automatically at the same timing as when the operation status of this product is changed to "RUN." (☞ Page 121 Auto start setting)

By also setting the auto start of the start up tool, a task can be run automatically at Windows logon after the personal computer starts. (☞ Page 34 Auto start)

Checking a task status

The following shows the procedure for checking a task.

Operating procedure

1. Select a target task in the task management screen, and click the [Task monitor] button. (Page 118 Task Management Screen)

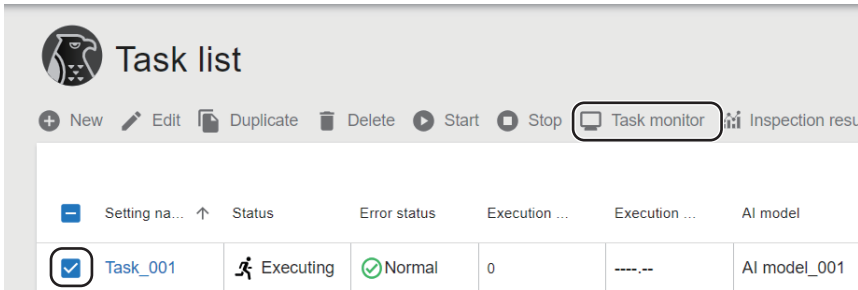

2. Select a target processing block in the custom monitor part selection area as indicated in (1). For details on the task monitor screen, refer to the following:

Page 167 Task Monitor Screen

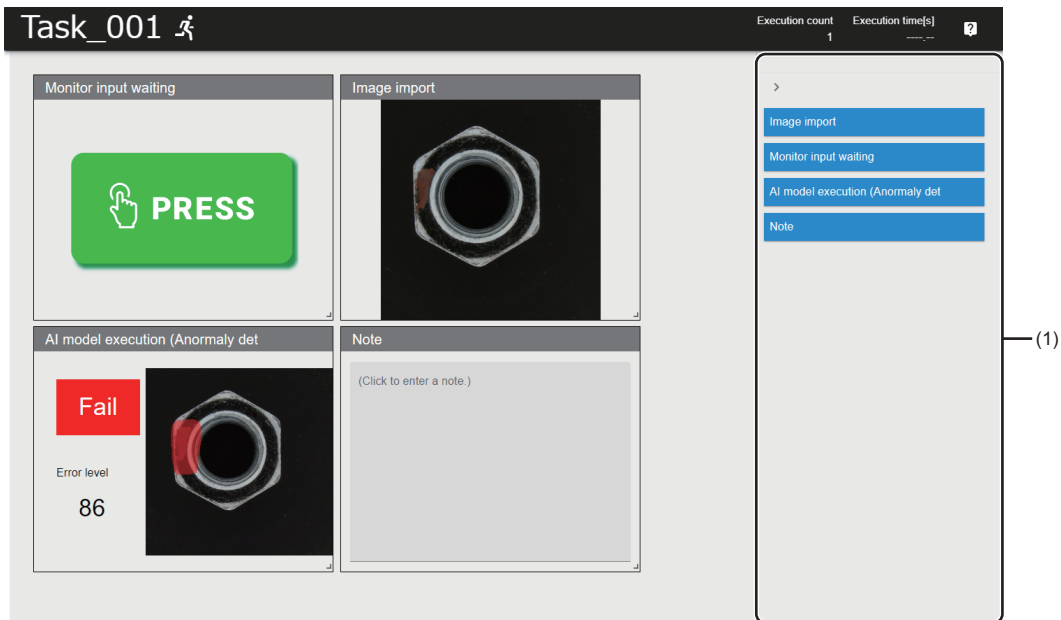

Point

- When performing inspection for image data using an AI model, the inspection result for each task processing can be checked in the task monitor screen.
- When using the monitor input waiting block, a paused task can be restarted from the task monitor screen.

Checking an inspection result history

The following shows the procedure for checking an inspection result history.

Point

An inspection result history is displayed when the inspection result history setting has been set.

☞ Page 112 Setting the inspection result history

Operating procedure

1. Select a target task in the task management screen, and click the [Inspection result history] button. (☞ Page 118 Task Management Screen)

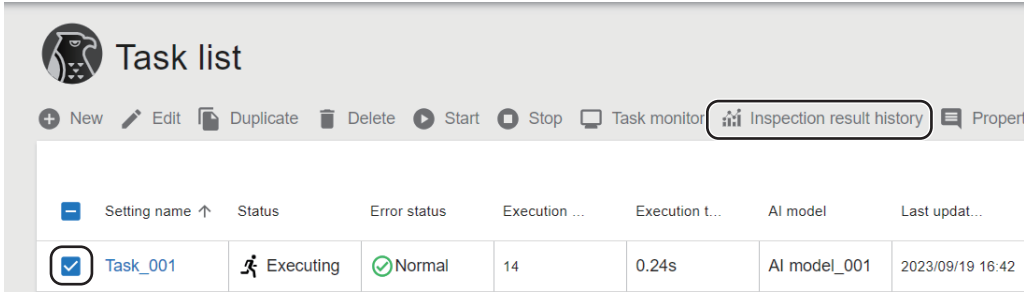

2. Select the update date and time (indicated in (1)) and data (indicated in (2)) of a task to be displayed. For details on the inspection result history check screen, refer to the following:

☞ Page 171 Inspection Result History Check Screen

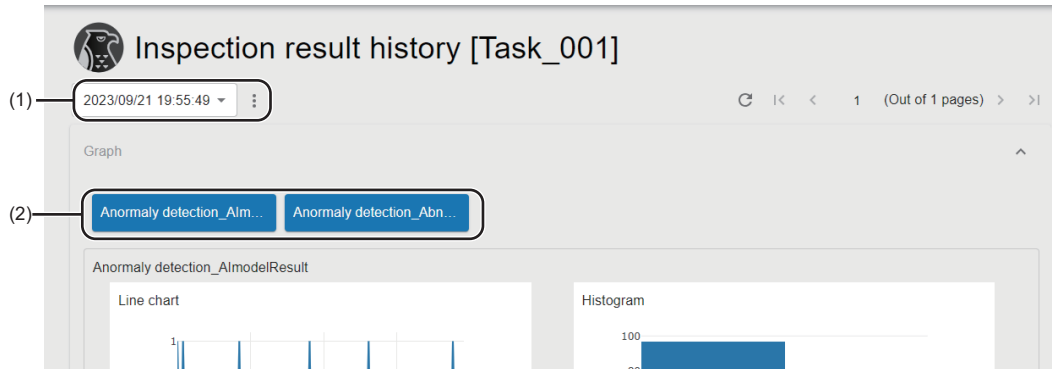

12.2 Improvement of AI Models

If the accuracy of an AI model is low, it may be improved by reviewing the following settings:

Setting	Description	Reference
Data set setting	Registering or deleting image data	Page 68 Data Set Setting Screen
	Reviewing labels	Page 68 Data Set Setting Screen
	Reviewing pixel marking (only for defective point detection)	Page 71 Pixel marking settings
AI model setting	Setting preprocessing	Page 89 Preprocessing selection screen
	Reviewing labels of the data set specified for learning in the AI engine setting	Page 93 AI engine setting screen
	Configuring the advanced setting in the AI engine setting	Page 97 Configuring the advanced setting
	Changing an AI engine	Page 93 AI engine setting screen

Point

- Learning must be performed again to apply the reviewed settings to an AI model. To keep the original AI model, duplicate it because the original one is deleted when learning is performed again.
- Image files saved as the inspection result history of a task can be registered to a data set.
( Page 171 Inspection Result History Check Screen)

12.3 Task Monitor Screen

This section shows the screen for checking the running status of a task and the latest execution result.

Processing blocks displayed on the screen can be freely customized to display only the required information.

The task monitor screen is updated at the following timings:

- At the completion of task processing
- At the execution of the monitor input waiting block
- At the status transition from 'Executing' to 'Transitioning to stop'

Point

- When performing inspection for image data using an AI model, the inspection result for each task processing can be checked in the task monitor screen.
 - When using the monitor input waiting block, a paused task can be restarted from the task monitor screen.
-

12

Precautions

If the task monitor screen of the same task is also displayed in another screen (such as another operation terminal, browser, and tab) and if contents to be displayed in the custom monitor display area are changed in either one of the screens, the information of some processing blocks will not be updated in the other screen until the task monitoring screen is opened again.

Window

Select a target task in the task management screen and click the [Task monitor] button. (☞ Page 118 Task Management Screen)

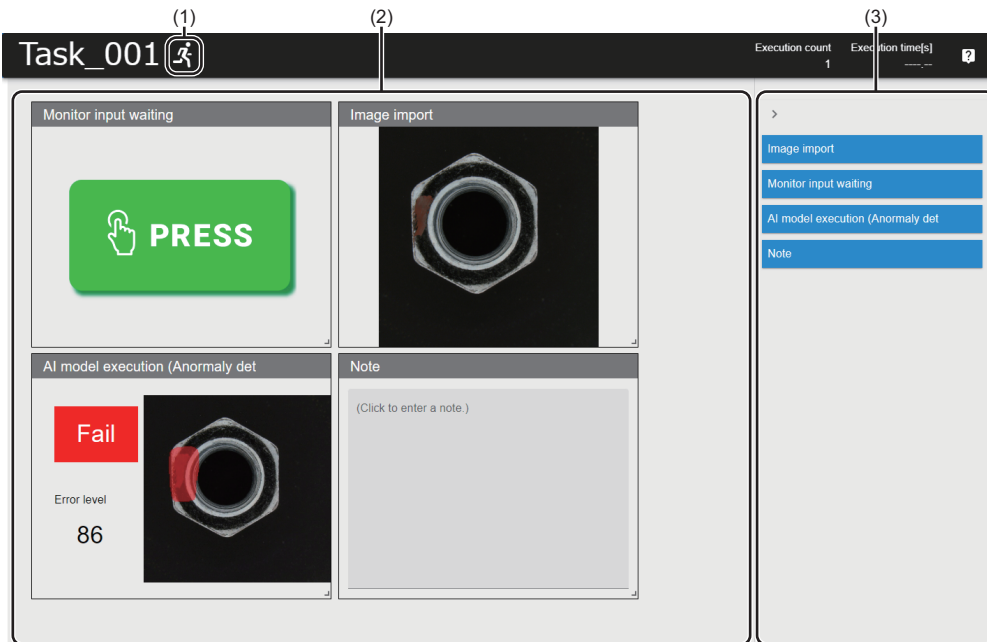

Displayed items

Item	Description
(1) Task status	The current task status is displayed. ☞ Page 103 Task status
Execution count	The number of times task processing is executed is displayed.
Execution time	The execution time of the last executed task processing is displayed.
(2) Custom monitor display area	Processing blocks selected in the custom monitor part selection area are displayed.*1 Processing blocks can be moved around and their size can be changed. For display contents of each processing block, refer to the following: ☞ Page 169 AI model execution block ☞ Page 169 Imaging block ☞ Page 169 Image import block ☞ Page 170 PLC data reading block ☞ Page 170 Monitor input waiting block ☞ Page 170 Memo block
(3) Custom monitor part selection area*2	Select a processing block to be displayed in the custom monitor display area. The following processing blocks cannot be selected: <ul style="list-style-type: none"> • PLC data writing block • Conditional branch block

*1 The monitor input waiting block is always displayed in the area when the block is included in a task.

*2 Displayed by clicking ☞.

AI model execution block

The execution result of the AI model execution block can be checked.

- Judgment result
- Error level (at anomaly detection)
- Error location (maximum/total) (at defective point detection)
- Heat map image

Window

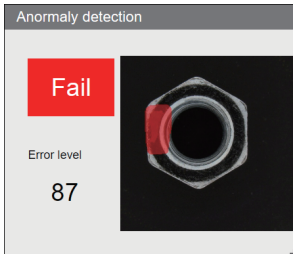

12

Imaging block

An image captured by a camera can be checked.

Window

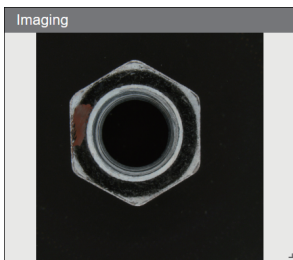
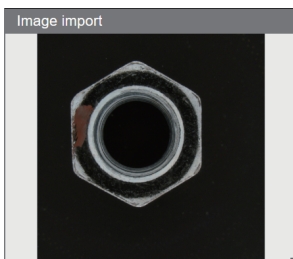

Image import block

An image imported by this block can be checked.

Window



PLC data reading block

The following information of a device read by this block can be checked:

- Device name
- Device value
- Comment

Window

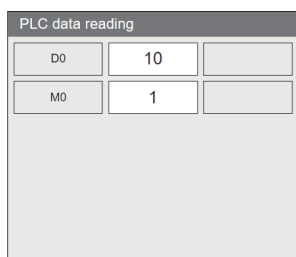

Monitor input waiting block

Task processing can be restarted by clicking the switch in the display while this block is executing.

Window

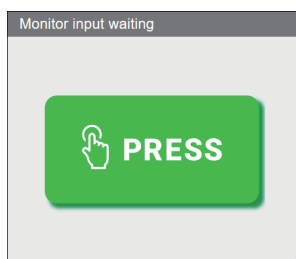

Memo block

A memo (0 to 1024 characters) can be set.

Window

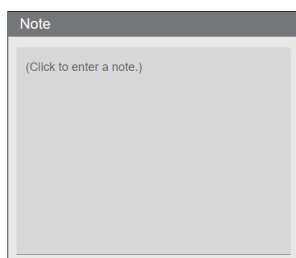

12.4 Inspection Result History Check Screen

This section shows the screen for checking the execution result of tasks executed in the past.

An inspection result history saved according to the inspection result history setting is read and graphs (a line chart and a histogram) and a list of saved data are displayed. (👉 Page 112 Setting the inspection result history)

Since inspection result histories of tasks with the same setting contents are displayed, the update date and time must be specified for the target period.

Point

This screen can be used not only for checking the saved data, but also for downloading the saved image file. The downloaded image file can be utilized as data to improve the accuracy of an AI model.

👉 Page 166 Improvement of AI Models

12

Precautions

- Do not edit, move, or delete a folder or file in the saving destination of an inspection result history. Otherwise, this product may not run properly.
- When opening this screen while a task is running, reading an inspection result history may fail.

Window

Select a target task in the task management screen, and click the [Inspection result history] button. (☞ Page 118 Task Management Screen)

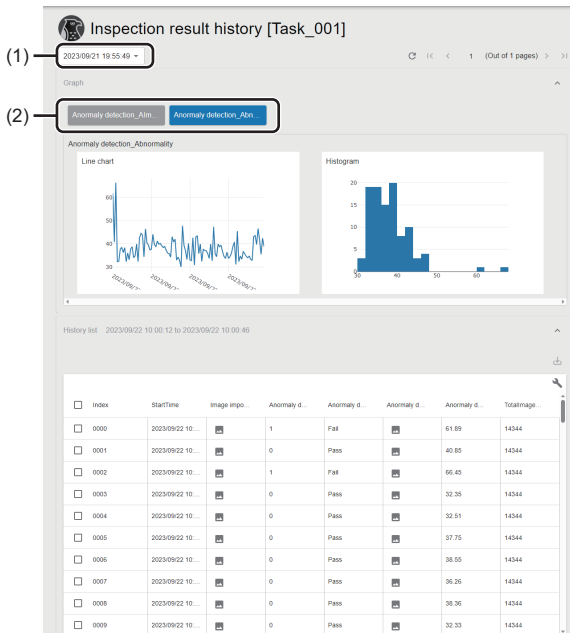

Displayed items

Item	Description	
(1) Target period	Select the update date and time of a task to be displayed.	
☰ (Menu for the target period)	Any of the following operations is performed for the target period: ■Export task setting The settings of tasks corresponding to the selected update date and time are saved in a format of the project file (.mscpp). Importing this file can restore the corresponding task. ■Delete history in the target period The inspection result histories of tasks corresponding to the selected update date and time are deleted. It is recommended to backup histories with "Export task setting" in advance because the deleted histories cannot be restored. ■Delete all task histories All inspection result histories of tasks are deleted. It is recommended to backup histories with "Export task setting" in advance because the deleted histories cannot be restored.	
🔄 (History update)	Click this to reload the display target data of an inspection result history.	
Graph	(2) Graph display data	Select data to be displayed on graphs.
	Line chart	The line chart of data selected for graph display data is displayed. The whole data is displayed as default and detailed value change can be checked by enlarging the graph.
	Histogram	The histogram of data selected for graph display data is displayed. The whole data is displayed as default and detailed value change can be checked by enlarging the graph.
History list	—	The output data of the read inspection result history is displayed. When the output data is an image file, the file can be displayed in another tab by clicking .
	(Image download)	Click this to download the image file of data selected in the history list. The accuracy of an AI model may be improved by registering the downloaded image file to a data set and generating the AI model again. ☞ Page 166 Improvement of AI Models For the downloaded folder configuration, refer to the following: ☞ Page 188 Image data downloaded in the inspection result history check screen



13 EVENT/ERROR HISTORY CHECK

This chapter shows the method for checking an event or error history that occurs while this product is running. Event or error histories are saved up to 10,000 histories. If the number of histories exceeds 10,000, histories are deleted in chronological order.

Precautions







This screen cannot be switched to another screen even by clicking a product logo or product name on the main bar. To switch this screen to another screen, perform an operation in the display source screen.

Window

Click  (Notify) on the main bar, and select [View event/error history list]. ( Page 39 Main bar)

No.	Date and time of occurrence	Latest date and time of occurrence	Number of occurrences	Project name	Function name	Function type	User ID	Severity	Event/error code	Overview
1	2023/08/29 17:40:46	2023/08/29 17:40:46	1	Project_002	Project_002	Project	User1	Information	21020003	Project import complete
2	2023/08/29 17:40:42	2023/08/29 17:40:42	1	Project_002	Project_002	Project	User1	Information	21020007	Project import start
3	2023/08/29 17:40:02	2023/08/29 17:40:02	1	Project_001	Project_001	Project	User1	Information	21020004	Project export complete
4	2023/08/29 17:39:54	2023/08/29 17:39:54	1	Project_001	Project_001	Project	User1	Information	21020008	Project export start
5	2023/08/29 17:39:30	2023/08/29 17:39:30	1	Project_001	AI model_003	AI	User1	Information	23050000	AI model threshold s...
6	2023/08/29 17:39:10	2023/08/29 17:39:10	1	Project_001	AI model_002	AI	User1	Information	23050000	AI model threshold s...
7	2023/08/29 17:38:12	2023/08/29 17:38:12	1	Project_001	Project_001	Project	User1	Warning	21020006	Project export failure

Displayed items

Item	Description	
 (Update)	Click this to update the event/error history list.	
 (Delete all)* ¹	Click this to delete all event/error history lists.	
(1) Event/error history list* ²	 (csv output)* ³	Click this to output the event/error history list to a CSV file.
	Date and time of occurrence	The data and time when an event or error occurred for the first time is displayed.
	Latest date and time of occurrence	The data and time when an event or error occurred the last time is displayed.
	Number of occurrences	The number of times an event or error has occurred is displayed. '1' is displayed when an event or error occurred for the first time. The value is incremented every time when the event or error with the same code occurs during the inspection which is performed continuously from the start to the end of task execution.
	Project name	A project name is displayed. "-" is displayed when the function is not managed by a project.
	Function name	The name of a function where an event or error occurred is displayed. "-" is displayed when a function name does not exist.
	Function type	The type of a function where an event or error occurred is displayed.
	User ID	The ID of a user who used a function where an event or error occurred is displayed. "-" is displayed when the user ID does not exist.
	Severity	The severity of an event or error is displayed. <ul style="list-style-type: none"> : Information : Warning : Error
	Event/error code	An event or error code is displayed.
Overview	The overview of an event or error is displayed.	

Item	Description
Event/error code	An event or error code of the selected event or error history is displayed.
Cause	The cause, corrective action, and contact information of the selected event or error history are displayed. "." is displayed in either of the following cases: <ul style="list-style-type: none"> When there is no cause, corrective action, or contact information When the severity of the event or error is "Information"
Corrective action	
Contact information	

- *1 Displayed when signing in as the administrative user. (📄 Page 43 User types)
- *2 An event/error to be displayed differs depending on a signed-in user.
 - Administrative user: All events/errors are displayed.
 - Standard user: Events/errors caused by the operation of the user are displayed. Events/errors of a project in which the user is set as a member at the time this screen is displayed are also displayed.
- *3 Displayed when expanding the header.

Precautions

If an event/error with the same event/error code occurs twice or more in the continuous diagnoses from when a task is started until when it is stopped, the second and later events/errors are not added but the latest occurrence time of the first event or error is updated instead, and the number of occurrences is also updated. (An event/error with the same code is added if it does not occur in the continuous diagnoses or it occurs after a task is stopped once then restarted.)

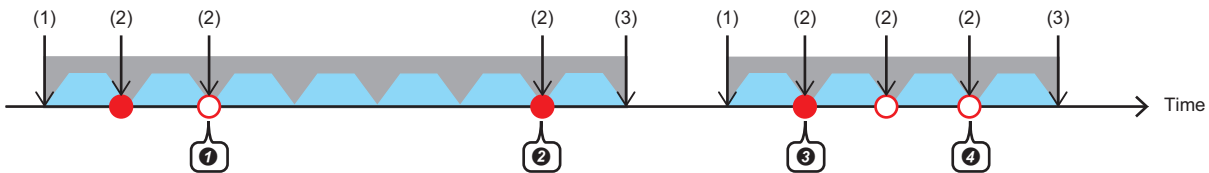

No.	Date and time of occurrence	Latest date and time of occurrence	Number of occurrences
1	2023/05/01 13:30:00.111	2023/05/01 13:50:00.111	3
2	2023/05/01 12:50:00.111	2023/05/01 12:50:00.111	1
3	2023/05/01 12:00:00.111	2023/05/01 12:10:00.111	2

- : An event that is added to an event/error history
- : An event that is not added to an event/error history but updates the latest occurrence time

- ▲ : One diagnosis
- : Task execution time

- (1) A task is executed.
- (2) Event 1 occurs.
- (3) The task is stopped.
- ① The event occurs in the continuous diagnoses; therefore, the latest occurrence time and number of occurrences are updated.
- ② The event does not occur in continuous diagnoses; therefore, it is newly added.
- ③ The event occurs after the task is stopped once then restarted; therefore, it is newly added.
- ④ The event occurs in the continuous diagnoses; therefore, the latest occurrence time and number of occurrences are updated.

CSV output

The event/error history list can be output as a CSV file.



A CSV file is output by the download function of a web browser.

■ File name

- eventlog_YYYYMMDD (date at CSV output).csv^{*1}

*1 Windows has a limit of the path length; therefore, a file name is shortened by a web browser. In addition, when a shortened file name is duplicated, the name is also changed according to the specifications of the web browser function.

■ Format specification

Item	Description
Delimiter	Comma (,)
Character code	UTF-8 (with BOM)
Maximum number of characters	<ul style="list-style-type: none">• No.: Five characters• Date and time of occurrence: 23 characters• Latest date and time of occurrence: 23 characters• Number of occurrences: Five characters• Project name: 32 characters• Function name: 10 characters• Function type: 6 characters (Data set)• User ID: 32 characters• Severity: 3 characters• Event/error code: 10 characters• Overview: 64 characters

■ Output contents

All of the saved event and error histories are output to a CSV file.

Item	Description
First line	A column name in the event/error history list is output with delimited by commas in order.
Second line	The information of one event or error history is output to fit on one line. (The icon in the severity column is not output.)

Ex.

```
No.,Date and time of occurrence,Latest date and time of occurrence,Number of occurrences,Project name,Function name,Function type,...  
1,2023/06/07 19:44:57.886,2023/06/07 19:44:57.886,1,Project_001,Task_001,Task,User1,Information,24010007,Task start success  
2,2023/06/07 19:42:14.422,2023/06/07 19:42:14.422,1,Project_001,Task_001,Task,User1,Information,24010009,Task stop success  
3,2023/06/07 19:41:22.305,2023/06/07 19:41:22.305,1,Project_001,Task_001,Task,User1,Information,24010007,Task start success  
4,2023/06/07 19:31:02.068,2023/06/07 19:31:02.068,1,Project_001,Task_001,Task,User1,Information,24010009,Task stop success  
5,2023/06/07 19:26:05.651,2023/06/07 19:26:05.651,1,Project_001,Task_001,Task,User1,Information,24010007,Task start success
```

14 PERSONAL SETTINGS

This chapter shows the screen for setting personal settings for a signed-in user (such as a display language and auto sign-out time).

Window

Click the user ID on the main bar and select [Personal setting]. (📖 Page 39 Main bar)

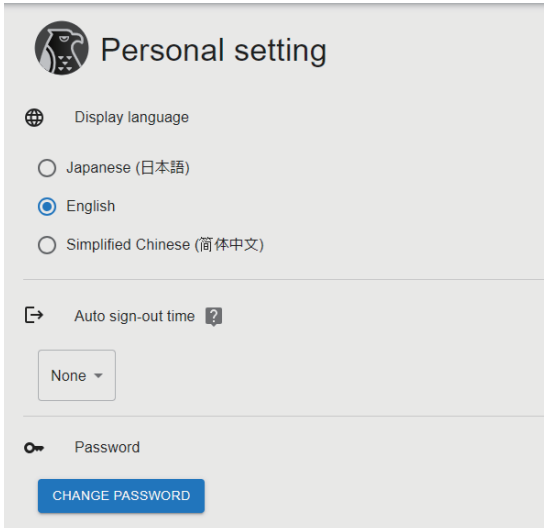

Displayed items

Item	Description
Display language	Switch a display language. The language of a web browser used when a user was signed in is set by default. (English is set when a language of the web browser was not Japanese, English, or Chinese.) The change of the display language is applied immediately. However, in a screen that is opened in a tab different from the one where the personal setting screen is opened, the change is not applied until reloading the screen or signing in to this product again.
Auto sign-out time	Set the amount of time before the user is signed out automatically.
Password	Click the [CHANGE PASSWORD] button to change a password. 📖 Page 177 Changing a password

Changing a password

The following shows the screen for changing a password.

Window

Change password

Current password

New password

Check new password

OK Cancel

Displayed items

Item	Description
Current password	Enter the current password.
New password	Set a new password (8 to 64 characters).
Check new password	Enter the password again for verification.



15 TROUBLESHOOTING BY SYMPTOM

If this product does not run properly, check the applicable items in the following and troubleshoot the error.

Common

Symptom	Check item	Corrective action
Unable to access a file/folder.	Is the network highly loaded?	Refer to the manual for the personal computer and reduce the load on the network.
	Is it written on the Windows system drive?	Change the writing destination drive.
	Does the file path exceed 259 characters?	Set the file path to save, export, read, or import data within 259 characters.
	Is the path of the access target an external folder such as a shared folder?	Check whether the external folder is accessible.
	Is there sufficient free space on the drive?	Secure free space on the drive.
The time is not displayed correctly in "Creation date and time" or "Last update date and time."	Is "time zone" changed in Windows settings?	<ul style="list-style-type: none"> • Refresh the screen. • Restart the browser.
	Is the setting of "Adjust for daylight saving time automatically" changed in Windows settings?	

Installation of this product

Symptom	Check item	Corrective action
Fails to install this product.	Is the operating system of a personal computer attempting the installation supported?	Install this product on a personal computer with a supported operating system.  MELSOFT VIXIO Installation Instructions
	Is there sufficient free space on the installation destination drive?	Delete files on the drive to secure free space required for installation.  MELSOFT VIXIO Installation Instructions
	Is another installer running?	Wait for the installation to be completed, then install this product again.

Registration of a license





Symptom	Check item	Corrective action
Unable to register a license.	Is the license file for another personal computer specified?	Register the correct license file that is issued for the personal computer in use.
	After registering the license file for the first time to the personal computer in use, is the date and time changed and is the time on Windows shifted before the license issue date and time?	Change the time on Windows to the time after the license issue date and time.
	After registering the license file for the first time to the personal computer in use, is the date and time changed and is the time on Windows shifted forward or backward for 24 hours or more?	Contact your local Mitsubishi Electric sales office or representative to acquire a new license, and register the license.

Operation start of this product

Symptom	Check item	Corrective action
The operation status does not switch to "RUN."	Is the server certificate valid?	Execute 'install_cert.bat' in the 'AIVICert' folder, which is in the installation destination of this product, with the administrator authority to install the server certificate in the operating environment. Then, start the operation of this product.
	Does the server certificate match with that in the connection destination?	Test the operation by changing the IP address to '127.0.0.1' in the connection settings of the startup tool, and then set an IP address again. ☞ Page 34 Setting
	Is the port number used by another application?	Review the port number in the connection settings of the startup tool. ☞ Page 34 Setting
	Is the set IP address correct?	Set the IP address that exists on the operating environment in the connection settings of the startup tool. ☞ Page 34 Setting
	Is the set IP address available?	Contact the network administrator to check whether the IP address is available. When using this product as a standalone product, change the IP address to '127.0.0.1' in the connection settings, then try again. ☞ Page 34 Setting
	Is a proxy server used? Alternatively, are multiple network adapters used?	When a proxy server is not required for the IP address set in the connection settings of the startup tool, exclude it from the proxy settings in the internet options. • Select [Internet Options] ⇒ [Connections] tab ⇒ [LAN settings] ⇒ [Advanced] in the control panel of Windows, and specify the IP address set in the connection settings of the startup tool as an exception.
	Is the load on the personal computer high?	• Reduce the load by closing other applications. • Install this product on a personal computer that satisfies requirements and recommendations for the operating environment. 📖 IMELSOFT VIXIO Installation Instructions
	Is a non-ASCII character used in the name of the folder where the installer is stored?	Move the installer to a folder of which the name consists of ASCII characters only, then install this product again.
	Is Windows Defender enabled?	Exclude the folder where this product is installed from the monitoring targets in the setting of Windows Defender. If the problem cannot be solved, install antivirus software, then disable Windows Defender.
Is a VPN client started in the learning machine or inspection machine to be run?	Stop the VPN client.	



Display in a web browser

Symptom	Check item	Corrective action
An error indicating that a URL cannot be found or reached is displayed in a web browser when attempting to display the operation screen.	Is the URL for displaying this product correct?	Acquire the correct URL in the startup tool. ☞ Page 33 Startup tool
	Is the operating status of the startup tool "STOP"?	Click  (Start operation), and display the operation screen after the operating status is changed to "RUN." ☞ Page 33 Startup tool
	Is this product started?	Start this product. ☞ Page 28 Startup Procedure for this Product
	Is the port number used by another application?	Review the port number in the connection settings of the startup tool. ☞ Page 34 Setting
	Is a proxy server used? Alternatively, are multiple network adapters used?	When a proxy server is not required for the IP address set in the connection settings of the startup tool, exclude it from the proxy settings in the internet options. • Select [Internet Options] ⇒ [Connections] tab ⇒ [LAN settings] ⇒ [Advanced] in the control panel of Windows, and specify the IP address set in the connection settings of the startup tool as an exception.
A message indicating that communication is not secure, such as 'privacy is not secured' or 'connection is not private,' is displayed.	Is the server certificate installed in the environment where operations are currently performed?	Install the server certificate in the environment where operations are currently performed. ☞ Page 30 Installing a server certificate
	Is the IP address of the learning machine or inspection machine changed?	Install the server certificate of the learning machine or inspection machine created after the IP address was changed in the environment where operations are currently performed. ☞ Page 30 Installing a server certificate
A screen turns white and nothing is displayed.	Does it take time to display the screen?	Wait for a while. If it is still not displayed, reload the page by using the web browser function.
	Is the web browser supported?	Use a supported web browser. ☞ Page 14 Operation terminal
A screen is not refreshed with the set or created contents.	Does it take time to display the screen?	Wait for a while. If it is still not displayed, reload the page by using the web browser function.
	Is the network in use switched during operation?	Wait for a while. If it is still not displayed, reload the page by using the web browser function. If the same symptom often occurs, operate this product in the stable communication environment where the network is not switched frequently.
	Is the communication environment stable?	
The project management screen is displayed with a specified URL.	Is the URL specified directly in a web browser?	Open a target data set or AI model from the management screen for each function.
	Is a page other than the sign-in screen specified for a shortcut or the favorites function?	☞ Page 65 Data Set Management Screen ☞ Page 83 AI Model Management Screen
The display language is different from the one displayed used when installing this product.	Is this product used for the first time after the installation?	Sign in to this product, then change the display language in the personal settings. ☞ Page 176 PERSONAL SETTINGS
The sign-in information is not retained.	Is the web browser set to not use Cookie?	Enable Cookie in the web browser settings.
	Was Cookie deleted in the web browser settings while using this product?	Sign in again. In addition, do not delete Cookie while using this product.
Contents in the screen are not displayed properly.	Is the screen of a web browser smaller than width 1500 px and height 822 px?	Change the screen size to width 1500 px and height 822 px or larger.
	Is a value other than 100% set for "Change the size of text, apps, and other items" in Windows?	Change the value to 100%.
	Is the zoom level set to a value other than 100% in the web browser?	Set an appropriate zoom level. ☞ Page 14 Operation terminal
Displayed screens or items are different from the ones shown in this manual.	Is old browsing data cached in the web browser?	Delete browsing data cached in the web browser, and display the screen again.

Symptom	Check item	Corrective action
The screen is not displayed properly (for example, an unexpected error occurs).	Can operations proceed in the screen?	<ul style="list-style-type: none"> Reload the page by using the web browser function. Alternatively, restart the web browser. Delete browsing data cached in the web browser, and display the screen again.
	Are there any problems with communication of the learning machine?	<ul style="list-style-type: none"> Check that this product is running. Review the route to the learning machine.
	Is there sufficient free space on the drive of the learning machine?	Delete unnecessary files to secure free space on the drive.  MELSOFT VIXIO Installation Instructions
	Is there sufficient free space on the memory of the learning station?	Close other applications.
	Is antivirus software interfering with this product?	Change settings of the antivirus software to exclude the following folder from the virus search targets: <ul style="list-style-type: none"> Installation folder of this product C:\ProgramData\MELSOFT\AIVI
	Is the error cleared after taking the above corrective actions?	If the error is not solved, contact your local Mitsubishi Electric sales office or representative.
An error message indicating that memory in a web browser is insufficient is displayed.	Are multiple tabs opened?	Close unnecessary tabs.
	Is there sufficient free space on the memory of the operation terminal?	Reduce the load by closing other applications.
		Close other tabs and windows in the web browser. Use a personal computer with 4 GB or more memory. For details on the required and recommended memory on the operation terminal, refer to the following:  Page 14 Operation terminal
Unable to sign in because a sign-in password is forgotten.		<p>■When there is another administrative user Sign in to this product as an administrative user, delete the target user account, and then create an account again.  Page 47 User Management Screen</p> <p>■When there is no other administrative users Uninstall this product from the learning machine or inspection machine, then reinstall it. When uninstalling this product, select "Delete all data" in the "Select deletion target" screen. Then, sign up with a new administrative account.*1  MELSOFT VIXIO Installation Instructions</p>
A message that the license is invalid is displayed.	Is the license registered in License Manager invalid?	<p>■When the license is valid Start the startup tool with the administrator authority and click  (Start operation) again.</p> <p>■When the license is invalid Update the license as it is expired.</p>

*1 By exporting projects, settings can be reproduced even after reinstalling this product.



Project

Symptom	Check item	Corrective action
Fails to create, import, or export a project.	Is there sufficient free space on the drive of the learning machine or inspection machine?	Secure free space on the drive.  MELSOFT VIXIO Installation Instructions
	Is the network highly loaded?	Refer to the manual for the personal computer and reduce the load on the network.
A created project is not displayed in the management screen.	Does a signed-in user have access authority to the project?	Sign in to this product as the administrative user, and set users that can access the project in the project management screen.  Page 50 Setting Members





Data set

Symptom	Check item	Corrective action
Fails to register image data.	Is there sufficient free space on the drive of the learning machine?	Secure free space on the drive.  MELSOFT VIXIO Installation Instructions

AI model

Symptom	Check item	Corrective action
Learning stops due to an error.	Is an error output in the event/error history?	Check "Corrective action" in the event/error history, and clear the error.
	Is the AI model setting in the generation failure state?	Open the "AI model validation" screen to check the description, and clear the error.
	Is the load on the personal computer high?	<ul style="list-style-type: none"> Reduce the load by closing other applications. Install this product on a personal computer that satisfies requirements and recommendations for the operating environment.  MELSOFT VIXIO Installation Instructions
Fails to save an AI model setting.	Is the setting screen for the same AI model displayed in multiple windows?	Close all the windows, and open the setting screen again in one window only.
	Is the learning machine offline?	Connect the terminals to display a web browser on the same network as the learning machine.
The operation is slow while learning.	Is the load on the personal computer high?	<ul style="list-style-type: none"> Reduce the load by closing other applications. Install this product on a personal computer that satisfies requirements and recommendations for the operating environment.  MELSOFT VIXIO Installation Instructions
Fails to deploy an AI model.	Is there sufficient free space on the drive of the learning machine or inspection machine?	Secure free space on the drive.  MELSOFT VIXIO Installation Instructions

Task

Symptom	Check item	Corrective action
Fails to create a task.	Is there sufficient free space on the drive of the learning machine or inspection machine?	Secure free space on the drive.  MELSOFT VIXIO Installation Instructions
Unable to execute a task.	Is an error output in the event/error history?	Check "Corrective action" in the event/error history, and clear the error.  Page 173 EVENT/ERROR HISTORY CHECK
	Is any of the blocks in the error state?	Click the error icon on the block to check the description, and clear the error.
	Is the load on the personal computer high?	<ul style="list-style-type: none"> Reduce the load by closing other applications. Install this product on a personal computer that satisfies requirements and recommendations for the operating environment.  MELSOFT VIXIO Installation Instructions
Fails to save a task setting.	Is the setting screen for the same task displayed in multiple windows?	Close all the windows, and open the setting screen again in one window only.
	Is the learning machine or inspection machine offline?	Connect the terminals to display a web browser on the same network as the learning machine or inspection machine.
The operation is slow while executing a task.	Is the load on the personal computer high?	<ul style="list-style-type: none"> Reduce the load by closing other applications. Install this product on a personal computer that satisfies requirements and recommendations for the operating environment.  MELSOFT VIXIO Installation Instructions
A task stops.	Are applications that consume a large amount of virtual memory used around the time when the task is stopped?	Specify the applications in the event viewer of Windows and stop unnecessary applications while this product is running.
Fails to deploy a task.	Is there sufficient free space on the drive of the learning machine or inspection machine?	Secure free space on the drive.  MELSOFT VIXIO Installation Instructions

Symptom	Check item	Corrective action
Starting or stopping a task takes time.	Does it take time to connect to the programmable controller and camera? Are there any errors in the status and connection route of the programmable controller and camera?	Check the status and connection route of the programmable controller and camera.
	Is the load on the network or CPU resource high?	Review the system configuration to reduce the load on the network and CPU resource, and try again.

Processing block

■ PLC data reading/PLC data writing

Symptom	Check item	Corrective action
An unintended value is read.	Is a file register address that does not exist in a connection destination device specified?	Review the address of the file register. (If the address is not in the connection destination device, an invalid value (such as 'FFFFH' or '-1') may be read.)
	Is a device number that does not exist in a connection destination device specified?	Check the device number range of the connection destination device, and specify a number within the range. (If the device number is not in the connection destination device, an invalid value (such as 'FFFFH' or '-1') may be read.)
An unintended value is written to a connection destination device.	Does another device write a value to the device set as the output destination?	Change the device.
	Does a program write a value to the device set as the output destination?	
A trigger does not occur in the intended cycle when reading data from a programmable controller.	Is the trigger monitoring cycle the intended setting?	Review the trigger monitoring cycle. ☞ Page 129 PLC data reading screen (device/trigger setting)
	Does it take time to connect to the programmable controller? Are there any errors in the status and connection route of the programmable controller?	Check the status and communication route of the programmable controller.
	Is the load on the network or CPU resource high?	Review the system configuration to reduce the load on the network and CPU resource, and try again.
Unable to read and write data.	Is a remote password set in a connection destination device?	Unlock the remote password for the connection destination device.
	Does a set device range match with the one for a connection destination device?	<ul style="list-style-type: none"> • Check the device range setting for the connection destination device, and set devices within the range. • Change the device range for a connection destination device.
	Are any packets lost in UDP communication?	<ul style="list-style-type: none"> • Change the communication to TCP communication. • Review the connection destination device or communication route. • Reduce the communication data amount or the frequency to connect to the connection destination device. • Divide the communication route to this product and other software. • Reduce simultaneous communications for one connection destination device.
No response is returned from a connection destination device.	Has a timeout occurred?	<ul style="list-style-type: none"> • Review the monitoring cycle setting of the PLC data reading block. (☞ Page 129 PLC data reading screen (device/trigger setting)) • Reduce the processing load on the connection destination device.
An unexpected error occurs.	Is a device number that is not supported by a connection destination device specified?	Check the device number range of the connection destination device, and specify a number within the range.
	Is antivirus software interfering with this product?	Change settings of the antivirus software to exclude the following folder from the virus search targets: <ul style="list-style-type: none"> • Installation folder of this product • C:\ProgramData\MELSOFT\AIVI

■ Imaging

At the processing block setting

Symptom	Check item	Corrective action
Noise is present in the captured image.	Is the frame rate set in "Advanced setting" high?	Set the frame rate low. ☞ Page 148 Imaging screen (parameter setting)
	Is the network highly loaded?	Reduce the load on the network.
	Are multiple cameras connected to the same LAN port using a switching hub?	<ul style="list-style-type: none"> • Reduce the number of cameras connected to the LAN port. • Review the configuration to use an Ethernet board so that a camera is connected to the LAN port on a 1:1 basis.
	Is the camera connected via a USB-Ethernet conversion adapter?	Connect the camera via an Ethernet board.
	Is the jumbo packet setting set?	Set a jumbo packet (jumbo frame) value in the network adapter settings. ❶ Right-click on a network adapter to be set and select [Properties] from the shortcut menu in Windows Device Manager. ❷ Change the jumbo packet (jumbo frame) setting in the [Details] tab.
	Are devices that are compatible with 100Base-T used in a connection route between a camera and a personal computer?	Use devices that are compatible with Gigabit Ethernet.
A camera is not recognized.	Is the power supplied to the camera?	Check the connection of the camera. After supplying power to the camera, refresh the browser and try again.
	Is the camera connected to the learning machine or inspection machine on a network?	After connecting the camera to the learning machine or inspection machine on a network, refresh the browser and try again.
	Are there any problems on the connection route?	<ul style="list-style-type: none"> • Reduce the load on the network. • Review the connection route.
	Has the connection to the camera been confirmed by this product?	Use a camera that has been confirmed for connection. 📖 Applicable Industrial Cameras for MELSOFT VIXIO (FA-A-0419) Alternatively, import image data from a file server using the image import block. ☞ Page 152 Image import block
	Is the camera available to communicate?	Refer to the manual for a camera to take corrective action. Alternatively, contact the manufacturer of the camera.
	Is Wi-Fi used for the personal computer?	A conflict may be occurred between the wired LAN port and Wi-Fi in the personal computer. Disconnect Wi-Fi and try again.
	Is the IP address that is the same as that of another network device used?	Check the IP address setting and try again.
	Is the IP address that is the same as that of the learning machine or inspection machine used?	
Communication with the camera cannot be started.	Is the connection destination of the camera correct?	Check the settings in the imaging screen (camera connection destination setting). ☞ Page 146 Imaging screen (camera connection destination setting)
A captured image is changed while a task is running.	Is this product or another application accessing the camera in use?	Stop and start the task again.
Another camera is connected.	Is the same IP address specified for multiple cameras?	Check the IP address setting of the cameras.
A connection to a camera is disconnected.	Are devices that are compatible with 100Base-T used in a connection route between a camera and a personal computer?	Use devices that are compatible with Gigabit Ethernet.

At a camera setting

Symptom	Check item and corrective action
The speed for capturing an image is slow.	<p>Check the frame rate setting.</p> <p>Shorten the exposure time. (☞ Page 148 Imaging screen (parameter setting))</p> <p>Check that devices which are compatible with 100Base-T are not used in a connection route between a camera and a personal computer.</p>
The camera cannot be connected.	Check the troubleshooting for "A camera is not recognized" under 'At the processing block setting.'
The captured image is not refreshed.	Click  (Update) in the imaging screen (parameter setting) and check if the camera is recognized. (☞ Page 148 Imaging screen (parameter setting))
An image cannot be captured.	<p>Check the firewall and proxy server settings.</p> <p>The packet size is too large for the network setting. Check the jumbo packet (jumbo frame) setting.</p> <p>❶ Right-click on a network adapter to be set and select [Properties] from the shortcut menu in Windows Device Manager.</p> <p>❷ Change the jumbo packet (jumbo frame) setting in the [Details] tab.</p>
Pitch-dark images are displayed.	<p>Check that a lens is attached to the camera.</p> <p>When a lens is attached, adjust the aperture of the lens.</p>
Black-and-white images are displayed even when using a color camera.	Check that a monochrome image format (such as "Mono8") is not set for "PixelFormat." (☞ Page 148 Imaging screen (parameter setting))

Image import

Symptom	Check item	Corrective action
Images are not imported when a file server is set as an import source.	Is the access authority to read folders or files on the file server granted?	Grant the access authority.

Task monitor

Symptom	Check item	Corrective action
The screen is not refreshed in real time.	Is the network highly loaded?	Refer to the manual for the personal computer and reduce the load on the network.

Error page

Symptom	Check item	Corrective action
A page showing 'Error404 Not Found' is displayed.	Is the page displayed directly by the favorites function of a web browser or a URL saved in the past?	<ul style="list-style-type: none"> • Check whether the address is correct. • Check whether the administrative user has changed the access authority of the project. • Check whether the target data such as project, data set, AI model, or task is not deleted. If it is deleted, the target page is not displayed.

APPENDIX

Appendix 1 Unusable Characters for this Product

This section shows the characters that cannot be used in this product.

- Control character codes (U+0000 to U+001F, U+007F to U+00A0, U+00AD, U+2028 to U+2029)
- Surrogate pair characters (U+D800 to U+DBFF, U+DC00 to U+DFFF)

In addition, there are some specific characters that are not allowed to be used in each screen. If any of the unusable characters is entered, an error will be notified.

Appendix 2 Folder Configuration

This section shows the configuration of folders used in this product.

Inspection result history

The following shows the folder configuration of an inspection result history. (☞ Page 112 Setting the inspection result history)

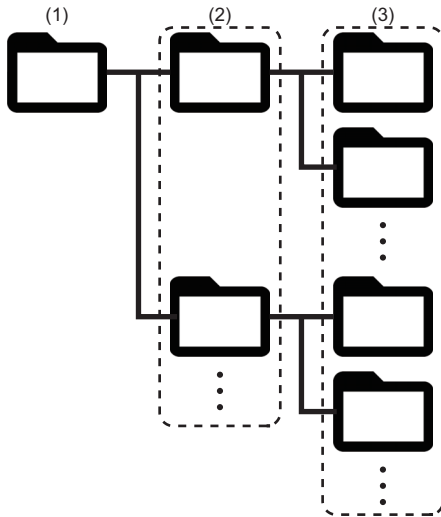

Item	Folder name, File name
(1) Saving destination folder	Any folder name specified in "Saving destination" of the inspection result history setting ☞ Page 112 Setting the inspection result history
(2) Project folder	'Project name of a target task' + '\$'
(3) Task folder	'Task name of a target task ^{*1} ' + '\$'

*1 '_IP address' is added to the folder name when the following conditions are satisfied: The saving destination specified in the inspection result history setting is same as the one specified in other learning machines or inspection machines, the project name and task name are same, and a task folder that has the same name already exists.

IP address is represented in eight-digit hexadecimal number 'X1X2X3X4,' and Xn indicates the nth octet.



Image data downloaded in the inspection result history check screen

The following shows the folder configuration of image data downloaded in the inspection result history check screen.

(☞ Page 171 Inspection Result History Check Screen)

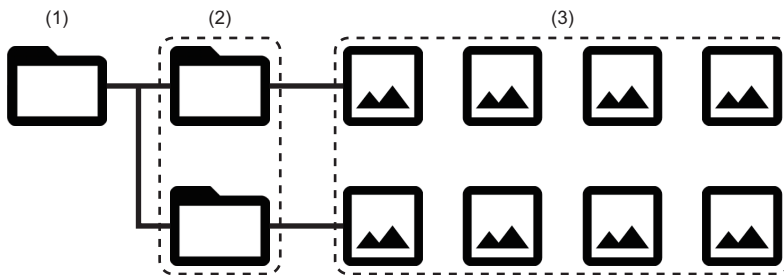

Item	Folder name, File name
(1) Folder for downloading	'The date and time when the folder for downloading was created' ^{*1} + '.zip'
(2) Block output folder	A block output folder name saved as an inspection result history 'Block name' + '_' + 'Data name'
(3) Image file	A file name of an image file saved as an inspection result history 'The value in the "Index" column' + 'Extension'

*1 The folder for download is named according to the date and time of when the folder was created.
The date and time of the learning machine or inspection machine where this product operates is used, and its format is 'YYYYMMDDhhmmss.'
YYYY, MM, DD, hh, mm, and ss indicate year, month, day, hour, minute, and second respectively. The number of digits corresponds with each number of characters.

Appendix 3 Software Licenses

This software consists of multiple software components. Each of them is copyrighted by Mitsubishi Electric and/or third parties.

Open source software used in this software and its conditions are described in a file in the installation folder.

Ex.

File location for the default installation folder

- C:\Program Files\MELSOFT\VIXIO\Doc\Info.txt

Source codes are not distributed for the software of Mitsubishi Electric and/or third parties.

Please refrain from inquiring about the source codes of this open source.

MEMO

INDEX

A

Access authority	46
Administrative user	43
Anomaly detection	73
Auto start	34,121

C

CSV output.	175
---------------------	-----

D

Defective point detection	74
Deploy	80,115

F

Full control	46
------------------------	----

I

Inspection result history	102
-------------------------------------	-----

L

Label	58
License Manager	35

P

Pixel marking	58
Processing block.	102

S

Standard user.	43
Startup tool.	33

T

Task flow	102
---------------------	-----



MEMO

REVISIONS

*The manual number is given on the bottom left of the back cover.

Revision date	*Manual number	Description
November 2023	SH(NA)-082628ENG-A	First edition

Japanese manual number: SH-082627-A

This manual confers no industrial property rights or any rights of any other kind, nor does it confer any patent licenses. Mitsubishi Electric Corporation cannot be held responsible for any problems involving industrial property rights which may occur as a result of using the contents noted in this manual.

© 2023 MITSUBISHI ELECTRIC CORPORATION

INFORMATION AND SERVICES

For further information and services, please contact your local Mitsubishi Electric sales office or representative.
Visit our website to find our locations worldwide.

MITSUBISHI ELECTRIC Factory Automation Global Website
Locations Worldwide
www.MitsubishiElectric.com/fa/about-us/overseas/

TRADEMARKS

Google Chrome is either a registered trademark or a trademark of Google LLC.

Intel is either a registered trademark or a trademark of Intel Corporation in the United States and/or other countries.

Microsoft, Microsoft Edge, and Windows are trademarks of the Microsoft group of companies.

Unicode is either a registered trademark or a trademark of Unicode, Inc. in the United States and other countries.

The company names, system names and product names mentioned in this manual are either registered trademarks or trademarks of their respective companies.

In some cases, trademark symbols such as [™] or [®] are not specified in this manual.

COPYRIGHTS

The screens (screenshots) are used in accordance with the Microsoft Corporation guideline.

For the open source software used in this product, refer to the following:

 Page 189 Software Licenses

SH(NA)-082628ENG-A(2311)

MODEL:SW1DND-AIVI-U-E

MITSUBISHI ELECTRIC CORPORATION

HEAD OFFICE: TOKYO BLDG., 2-7-3, MARUNOUCHI, CHIYODA-KU, TOKYO 100-8310, JAPAN
NAGOYA WORKS: 1-14, YADA-MINAMI 5-CHOME, HIGASHI-KU, NAGOYA 461-8670, JAPAN

When exported from Japan, this manual does not require application to the
Ministry of Economy, Trade and Industry for service transaction permission.

Specifications subject to change without notice.