

**A/B/Z-PHASE DIFFERENTIAL INPUT INTERFACE UNIT**

**MODEL**  
**MR-J2S-CLP01**  
**INSTRUCTION MANUAL**

C

● **Safety Instructions** ●

(Always read these instructions before using the equipment.)

Do not attempt to install, operate, maintain or inspect the servo amplifier and servo motor until you have read through this Installation Guide, corresponding instruction manuals and appended documents carefully and can use the equipment correctly. Do not use the servo amplifier and servo motor until you have a full knowledge of the equipment, safety information and instructions.

In this Installation Guide, the safety instruction levels are classified into "WARNING" and "CAUTION".

	Indicates that incorrect handling may cause hazardous conditions, resulting in death or severe injury.
	Indicates that incorrect handling may cause hazardous conditions, resulting in medium or slight injury to personnel or may cause physical damage.

Note that the CAUTION level may lead to a serious consequence according to conditions. Please follow the instructions of both levels because they are important to personnel safety. What must not be done and what must be done are indicated by the following diagrammatic symbols:

	Indicates what must not be done. For example, "No Fire" is indicated by .
	Indicates what must be done. For example, grounding is indicated by .

In this Installation Guide, instructions at a lower level than the above, instructions for other functions, and so on are classified into "POINT". After reading this installation guide, always keep it accessible to the operator.

1. To prevent electric shock, note the following:

WARNING	
<ul style="list-style-type: none"> <li>Before wiring or inspection, switch power off and wait for more than 10 minutes. After the charge lamp of the servo amplifier has turned off, confirm the voltage is safe with voltage tester. Otherwise, you may get an electric shock.</li> <li>Connect the interface unit and servo amplifier and servo motor to ground.</li> <li>Any person who is involved in wiring and inspection should be fully competent to do the work.</li> <li>Do not attempt to wire the interface unit until they have been installed. Otherwise, you may get an electric shock.</li> <li>Operate the switches with dry hand to prevent an electric shock.</li> <li>The cables should not be damaged, stressed, loaded, or pinched. Otherwise, you may get an electric shock.</li> </ul>	

2. To prevent fire, note the following:

CAUTION	
<ul style="list-style-type: none"> <li>Do not install the interface unit on or near combustibles. Otherwise a fire may cause.</li> </ul>	

3. To prevent injury, note the follow

CAUTION	
<ul style="list-style-type: none"> <li>Only the voltage specified in the Instruction Manual should be applied to each terminal. Otherwise, a burst, damage, etc. may occur.</li> <li>Connect the terminals correctly to prevent a burst, damage, etc.</li> <li>Ensure that polarity (+, -) is correct. Otherwise, a burst, damage, etc. may occur.</li> </ul>	

4. Additional instructions

The following instructions should also be fully noted. Incorrect handling may cause a fault, injury, electric shock, etc.

(1) Transportation and installation

CAUTION	
<ul style="list-style-type: none"> <li>Transport the products correctly according to their weights.</li> <li>Stacking in excess of the specified number of products is not allowed.</li> <li>Install the interface unit in a load-bearing place in accordance with the Instruction Manual.</li> <li>Do not climb or stand on servo equipment. Do not put heavy objects on equipment.</li> <li>The interface unit must be installed in the specified direction.</li> <li>Do not install or operate the interface unit which has been damaged or has any parts missing.</li> <li>Provide adequate protection to prevent screws and other conductive matter, oil and other combustible matter from entering the interface unit.</li> <li>Do not drop or strike interface unit. Isolate from all impact loads.</li> <li>Use the interface unit under the following environmental conditions:</li> </ul>	
Environment	Conditions
Ambient temperature	0 to +55 [°C] (non-freezing) 32 to 131 [°F] (non-freezing)
Ambient humidity	90%RH or less (non-condensing)
Storage temperature	-20 to +65 [°C] (non-freezing) -4 to 149 [°F] (non-freezing)
Storage humidity	90%RH or less (non-condensing)
Ambience	Indoors (no direct sunlight) Free from corrosive gas, flammable gas, oil mist, dust and dirt
Altitude	Max. 1000m (3280 ft) above sea level
Vibration	[m/s <sup>2</sup> ] 5.9 or less [ft/s <sup>2</sup> ] 19.4 or less
<ul style="list-style-type: none"> <li>When the equipment has been stored for an extended period of time, consult Mitsubishi.</li> </ul>	

(2) Usage

CAUTION	
<ul style="list-style-type: none"> <li>Any person who is involved in disassembly and repair should be fully competent to do the work.</li> <li>Do not modify the equipment.</li> <li>Use a noise filter, etc. to minimize the influence of electromagnetic interference.</li> <li>Before switching power on, confirm that the internal setting switch (SW1) is set correctly.</li> </ul>	

(3) Disposal

CAUTION	
<ul style="list-style-type: none"> <li>Dispose of the product as general industrial waste.</li> </ul>	

**1 INTRODUCTION**

POINT	
<ul style="list-style-type: none"> <li>A dedicated servo amplifier is needed to use this interface unit. Consult us for details of the servo amplifier.</li> </ul>	

1.1 Introduction

The MR-J2S-CLP01 A/B/Z-phase differential input interface unit is designed to convert the A/B/Z-phase differential driver signals into signals that can be input to the servo amplifier.

1.2 Contents of packing

Contents	Quantity
A/B/Z-phase differential input interface unit	1
A/B/Z-phase differential input interface unit installation guide	1

1.3 Model code definition

<b>MITSUBISHI</b>	
MODEL	MR-J2S-CLP01
INPUT	0.3A DC4.85-5.25V
SERIAL	SAMPLE001 TC350A065G51
PASSED	

Model  
Applicable power supply  
Serial number

**2 SPECIFICATION**

2.1 Specification list

Item	Description	
Type	MR-J2S-CLP01	
Power supply	Permissible voltage fluctuation	4.85 to 5.25VDC
	Current consumption	200mA (when power is supplied from servo amplifier) 250mA (when power is supplied from external power supply) (Note)
Input signal	A/B/Z-phase differential input signal	
Minimum phase difference	500ns	
Output signal	Fast serial communication	
Structure	Open(IP00)	
Environment	Ambient temperature	0 to +55[°C] (non-freezing) 32 to +131[°F] (non-freezing)
	Ambient humidity	90%RH or less (non-condensing)
	Storage temperature	-20 to +65[°C] (non-freezing) -4 to +149[°F] (non-freezing)
	Storage humidity	90%RH or less (non-condensing)
	Ambient	Indoors (no direct sunlight) Free from corrosive gas, oil mist, dust and dirt
	Altitude	Max. 1000m(3280ft) above sea level
	Vibration	5.9 [m/s <sup>2</sup> ] 19.4 [ft/s <sup>2</sup> ]
Mass	[kg]	0.4
	[lb]	0.88

(Note) Power for a linear scale is not included. When an external power supply is used, a linear scale of up to 350mA can be used.

2.2 Outline dimension drawings

Terminal arrangement

TE1	PSL	Model	Mass
	PSG		
	PE	MR-J2S-CLP01	0.4 (0.88)

**3 SIGNAL EXPLANATION**

3.1 Terminal block

POINT	
<ul style="list-style-type: none"> <li>Connection with the incorrect polarity of the connected power supply causes the interface unit to fail.</li> </ul>	

Signal name	Symbol	Terminal	Function/Application
Stabilized power supply	P5L	TE1	Connect to the stabilized power supply 5VDC(+).
	P5G	TE1	Connect to the stabilized power supply 5VDC(-). Connected with LG.
Grounding	PE	Chassis	Connect to the PE terminal of the servo amplifier.

3.2 Connector

3.2.1 Applications of connectors

Connector name	Plugged Connector	Function/Application
CN1A	Connector 10114-3000VE(3M) Shell kit 10314-52F0-008	For A/B/Z-phase differential input (For connection of linear scale)
CN1B	Connector 10120-3000VE(3M) Shell kit 10320-52F0-008	For connection of servo motor
CN2	Connector 10120-3000VE(3M) Shell kit 10320-52F0-008	For connection of servo motor
CN3		Not used.

3.2.2 Input signal

(1) CN1A

Signal name	Symbol	Connector pin	Function/Application
A-phase pulse (Differential line driver)	LA	2	A-phase pulse input
	LAR	3	
B-phase pulse (Differential line driver)	LB	4	B-phase pulse input
	LBR	5	
Z-phase pulse (Differential line driver)	LZ	6	Z-phase pulse input
	LZR	7	
Alarm pulse (Differential line driver)	LAL	8	Alarm signal of encoder is entered. Do not connect when encoder has no alarm output.
	LALR	9	
Power supply (5V)	P5L	14	5VDC power supply terminal
Power supply (0V)	LG	1	Common terminal for P5L
Shield	SD	Plate	Connect external conductor of shielded cable.

(2) CN1B

Signal name	Symbol	Connector pin	Function/Application
Serial communication	MR	7	Communication signal with servo motor
	MRR	17	
Serial communication	P5	18,19,20	For supplying 5VDC power to servo motor
	LG	1,2,11,12	Common terminal for P5
	SD	Plate	Connect external conductor of shielded cable.

(3) CN2

Signal name	Symbol	Connector pin	Function/Application
Serial communication	MR	7	Communication signal with servo motor
	MRR	17	
Serial communication	P5	18,19,20	For supplying 5VDC power to servo motor
	LG	1,2,11,12	Common terminal for P5
	SD	Plate	Connect external conductor of shielded cable.

### 3.3 Input signal specifications

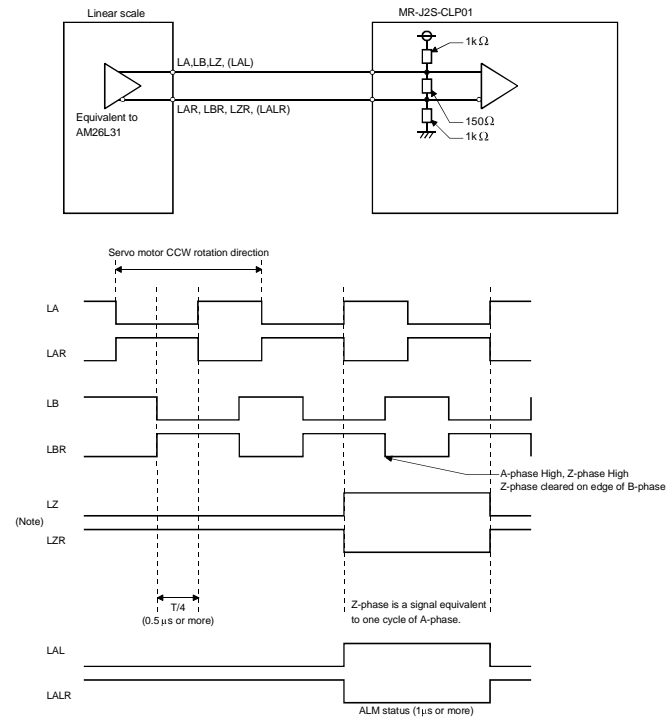

Note: The linear scale that does not include Z-phase is inapplicable.

## 4 FULLY CLOSED CONTROL SYSTEM

### 4.1 Setting of internal setting switch (SW1)

When using the interface unit as the converter of the encoder in the fully closed control system, always set SW1 to the "CLOSE" position.

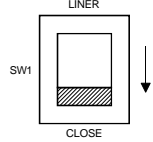

### 4.2 Connection diagram

#### 4.2.1 When supplying power to the linear scale directly

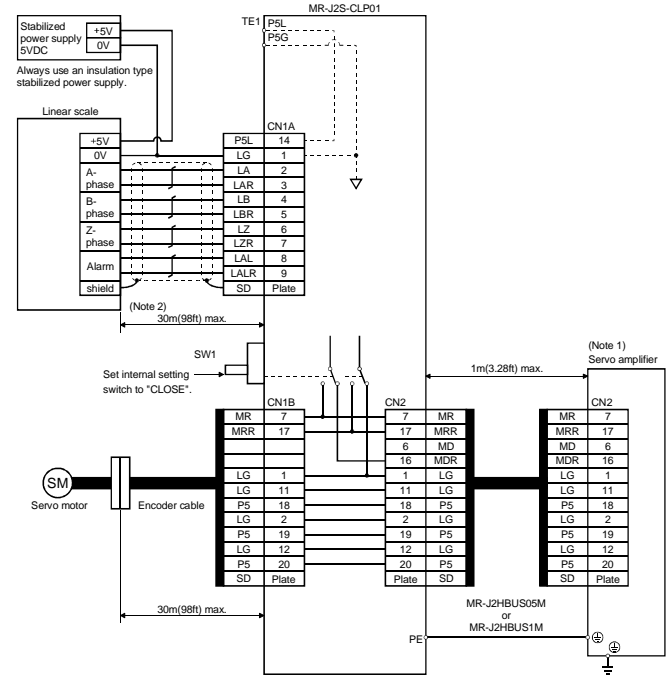

Note 1. For servo amplifier wiring, refer to the servo amplifier specifications guide.  
2. 30m(98ft) max. depending on the linear scale specifications.  
Also consider that there is no influence of voltage drop when wiring.

### 4.2.2 When supplying power to the linear scale via the interface unit

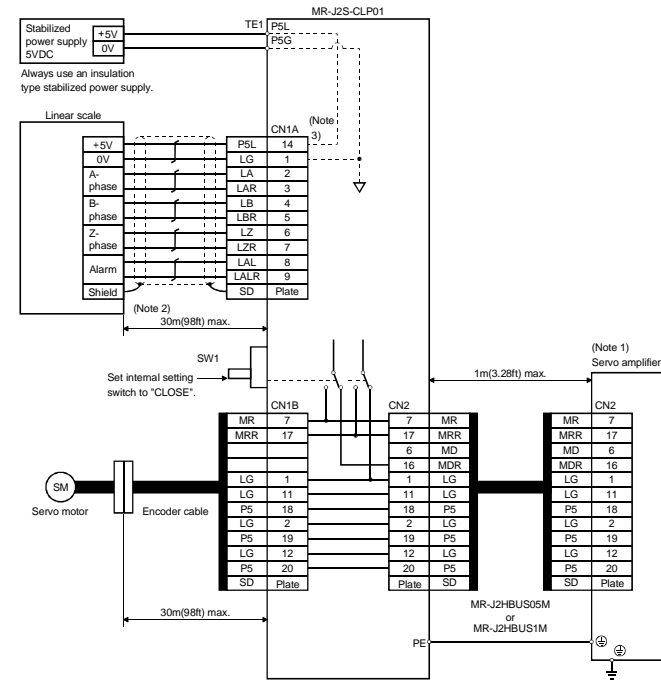

Note 1. For servo amplifier wiring, refer to the servo amplifier specifications guide.  
2. 30m(98ft) max. depending on the linear scale specifications.  
Also consider that there is no influence of voltage drop when wiring.  
3. When supplying power from P5L to the linear scale, the voltage is 50mV lower than that when power is supplied directly to the linear scale because of a voltage drop within the MR-J2S-CLP01.

## 5 LINEAR SERVO MOTOR CONTROL SYSTEM

### 5.1 Setting of Internal setting switch (SW1)

When using the interface unit as the converter of the encoder in the linear servo motor control system, always set SW1 to the "LINEAR" position.

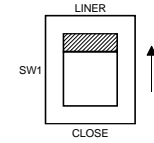

### 5.2 Connection diagram

#### 5.2.1 When the current consumption of the linear scale is 150mA or more

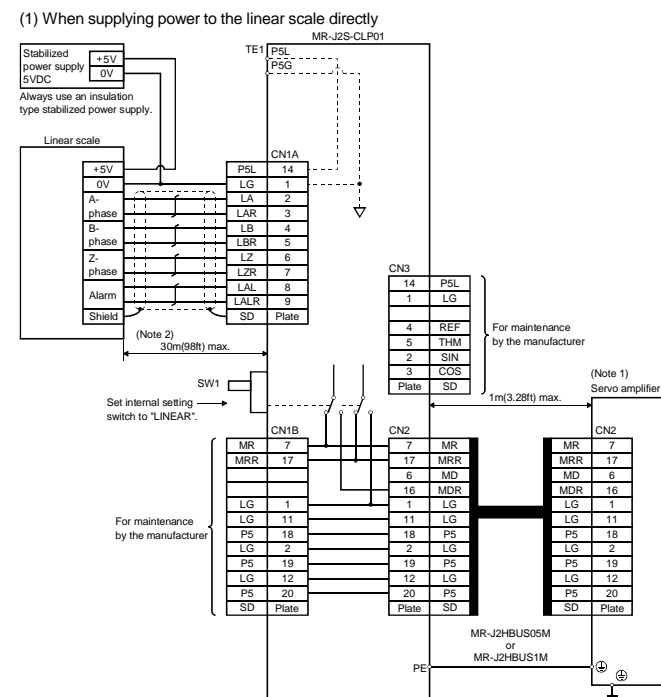

Note 1. For servo amplifier wiring, refer to the servo amplifier specifications guide.  
2. 30m(98ft) max. depending on the linear scale specifications.  
Also consider that there is no influence of voltage drop when wiring.

### (2) When supplying power to the linear scale via the interface unit

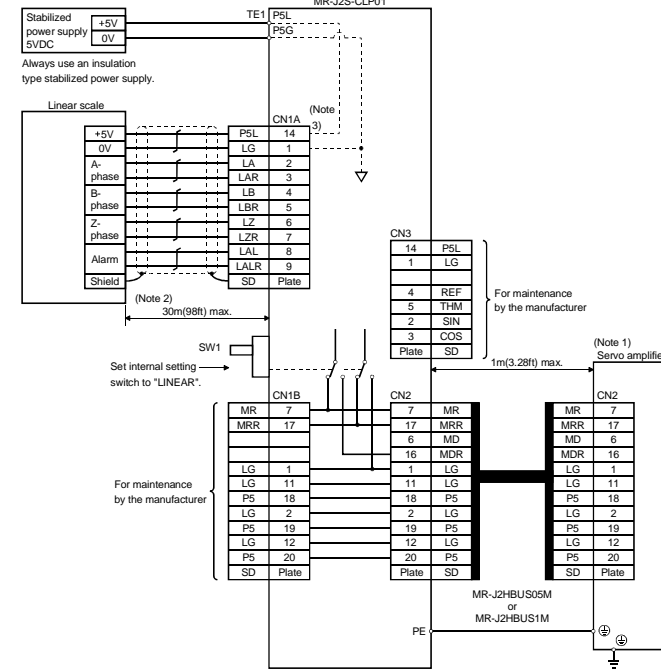

Note 1. For servo amplifier wiring, refer to the servo amplifier specifications guide.  
2. 30m(98ft) max. depending on the linear scale specifications.  
Also consider that there is no influence of voltage drop when wiring.  
3. When supplying power from P5L to the linear scale, the voltage is 50mV lower than that when power is supplied directly to the linear scale because of a voltage drop within the MR-J2S-CLP01.

#### 5.2.2 When the current consumption of the linear scale is less than 150mA

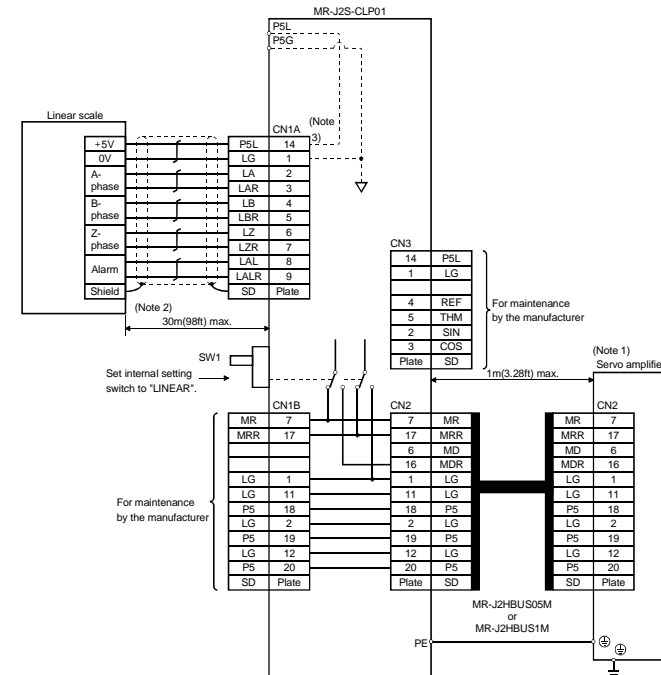

Note 1. For servo amplifier wiring, refer to the servo amplifier specifications guide.  
2. 30m(98ft) max. depending on the linear scale specifications.  
Also consider that there is no influence of voltage drop when wiring.  
3. When the external power supply is not used, 4.85 to 5.25VDC (150mA) can be supplied from the servo amplifier.

When supplying 5V power to the linear scale through an external power supply, make sure to power ON as described in the following sequence.

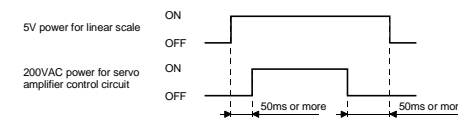

## 6 NOISE REDUCTION TECHNIQUUS

Providing a data line filter in the wiring section of the linear scale side has an effect to prevent noise entry. For example, the ZCAT3035-1330 of TDK make and the ESD-SR-25 of Tokin make are available as data line filters. As reference example, the impedance specifications of the ZCAT3035-1330(TDK make) are indicated below. This impedance are reference values and not guaranteed values.

