

MITSUBISHI CNC

MELDAS M600 Series

MAINTENANCE MANUAL

Precautions for Safety

Always read the specifications issued by the machine maker, this manual, related manuals and attached documents before installation, operation, programming, maintenance or inspection to ensure correct use. Understand this numerical controller, safety items and cautions before using the unit.

This manual ranks the safety precautions into "Danger", "Warning" and "Caution".



DANGER

When the user may be subject to imminent fatalities or major injuries if handling is mistaken.



WARNING

When the user may be subject to fatalities or major injuries if handling is mistaken.



CAUTION

When the user may be subject to injuries or when physical damage may occur if handling is mistaken.



Note that even items ranked as " **CAUTION**" may lead to major results depending on the situation. In any case, important information that must always be observed is described.

DANGER

There are no "Danger" items in this manual.



WARNING

1. Items related to prevention of electric shocks







-  Do not operate the switches with wet hands, as this may lead to electric shocks.
-  Do not damage, apply excessive stress, place heavy things on or sandwich the cables, as this may lead to electric shocks.

CAUTION

1. Items related to noise

-  Always treat the shield cables indicated in this manual with grounding measures such as cable clamps.
-  Separate the signal wire from the drive line/power line when wiring.







2. Items related to installation

-  Install each unit on noncombustible material. Installation directly on or near combustible material may lead to fires.
-  Always observe the installation direction.
-  Do not install or operate units that are damaged or that have missing parts.
-  Do not allow conductive foreign matter such as screw or metal chips or combustible foreign matter such as oil enter each unit.
-  Each unit is a precision device so do not drop or apply strong impacts on the device.
-  Install at a position where cutting oil will not get on the NC Card.



(Continued on next page)

 **CAUTION**

3. Items related to connection

-  Do not apply voltages other than those indicated in this manual on the conductor. Doing so may lead to destruction or damage.
-  Incorrect connections may damage the devices, so connect the cables to the specified connectors.
-  When using an inductive load such as relays, always connect a diode in parallel to the load as a noise measure.
-  When using a capacitive load such as a lamp, always connect a protective resistor serially to the load to suppress rush currents.
-  Do not connect or disconnect the connection cables between each unit while the power is ON.
-  Do not connect or disconnect the PCBs while the power is ON.

4. Items related to battery

-  If the battery low warning is issued, save the machining programs, tool data and parameters in the input/output device, and then replace the battery.
-  Do not short circuit, charge overheat, incinerate or disassemble the battery.
-  Dispose of spent batteries according to local laws.

CONTENTS

1. OUTLINE	1
1.1 System Configuration	1
1.1.1 Outline drawing	1
1.1.2 System outline drawing	2
1.1.3 Configuration	3
2. EXPLANATION OF MODULE FUNCTIONS	6
2.1 HR111 Card	6
2.2 HR121 Card	8
2.3 HR081 Card	10
2.4 HR841 Card	12
2.5 HR273 Card	13
2.6 HR371 Card	14
2.7 HR325, 327, 335, 337 Cards	15
2.8 Floppy Disk	17
3. TROUBLESHOOTING	18
3.1 List of Unit LEDs	18
3.2 Troubleshooting	20
3.2.1 Confirmation of trouble state	20
3.2.2 When in trouble	21
4. DAILY MAINTENANCE AND PERIODIC INSPECTION AND MAINTENANCE	27
4.1 Maintenance Tools	27
4.2 Maintenance Items	28
4.3 Replacement Methods	29
4.3.1 Cable	29
4.3.2 Durable parts	31
(1) Battery	31
(2) Backlight	32
(3) Cooling fan	33
(4) Hard disk (HDD)	34
(5) Floppy disk (FDD)	37
4.3.3 Unit	38
(1) Control unit	38
(2) Control section	39
(3) Display section (LCD panel)	40
(4) Base I/O unit	41
(5) External power supply unit (PD25)	42
(6) PCMCIA card	43
(7) Keyboard	44
4.3.4 Control PCB	45
(1) Control section power supply PCB (HR081)	45
(2) PCMCIA interface PCB (HR841)	46
(3) Backlight power supply PCB	47
(4) LCD signal interface PCB (HR273)	48
(5) Expansion PCB	49
(6) Cassette memory	50
(7) Card-sized I/O (HR361, HR371)	51
4.4 Cleaning and Handling	52
4.4.1 Escutcheon	52
4.4.2 Floppy disk drive	52
4.4.3 Hard disk	55
4.4.4 LCD panel	55
4.4.5 PCMCIA card	56

1. OUTLINE

1.1 System Configuration

1. OUTLINE

1.1 System Configuration

1.1.1 Outline drawing

The basic configuration of the M600 system is that with the control section attached to the LCD display section.

(1) Front view

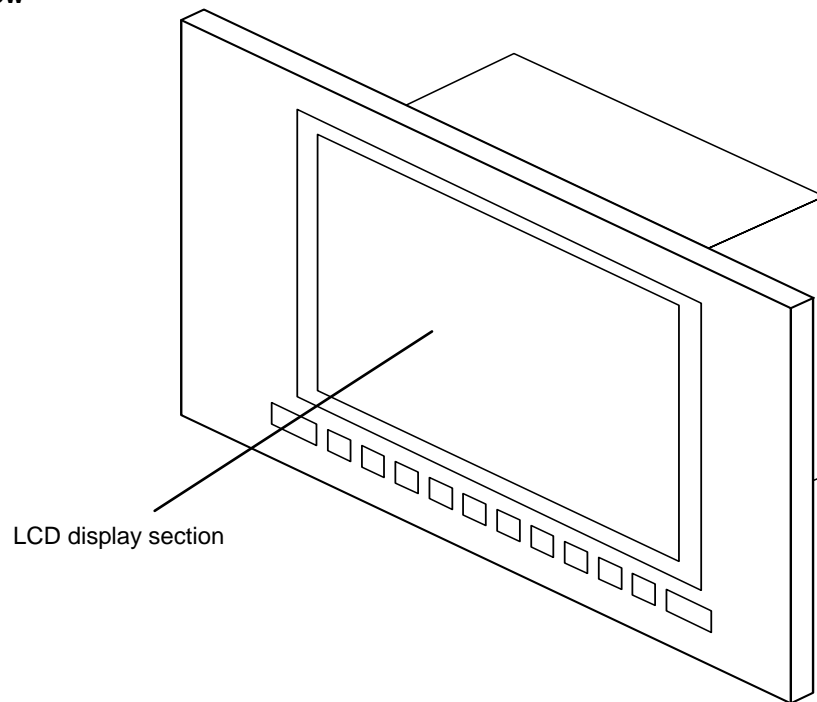

(2) Rear view

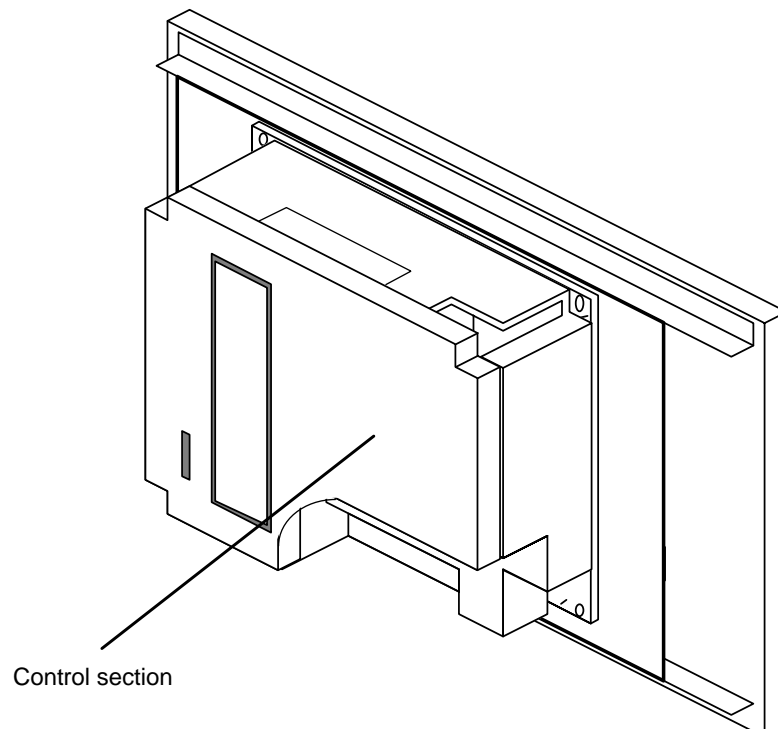

1. OUTLINE

1.1 System Configuration

1.1.2 System outline drawing

With the M600 system, connections are made with the drive section through a remote I/O separated from the control section as shown below.

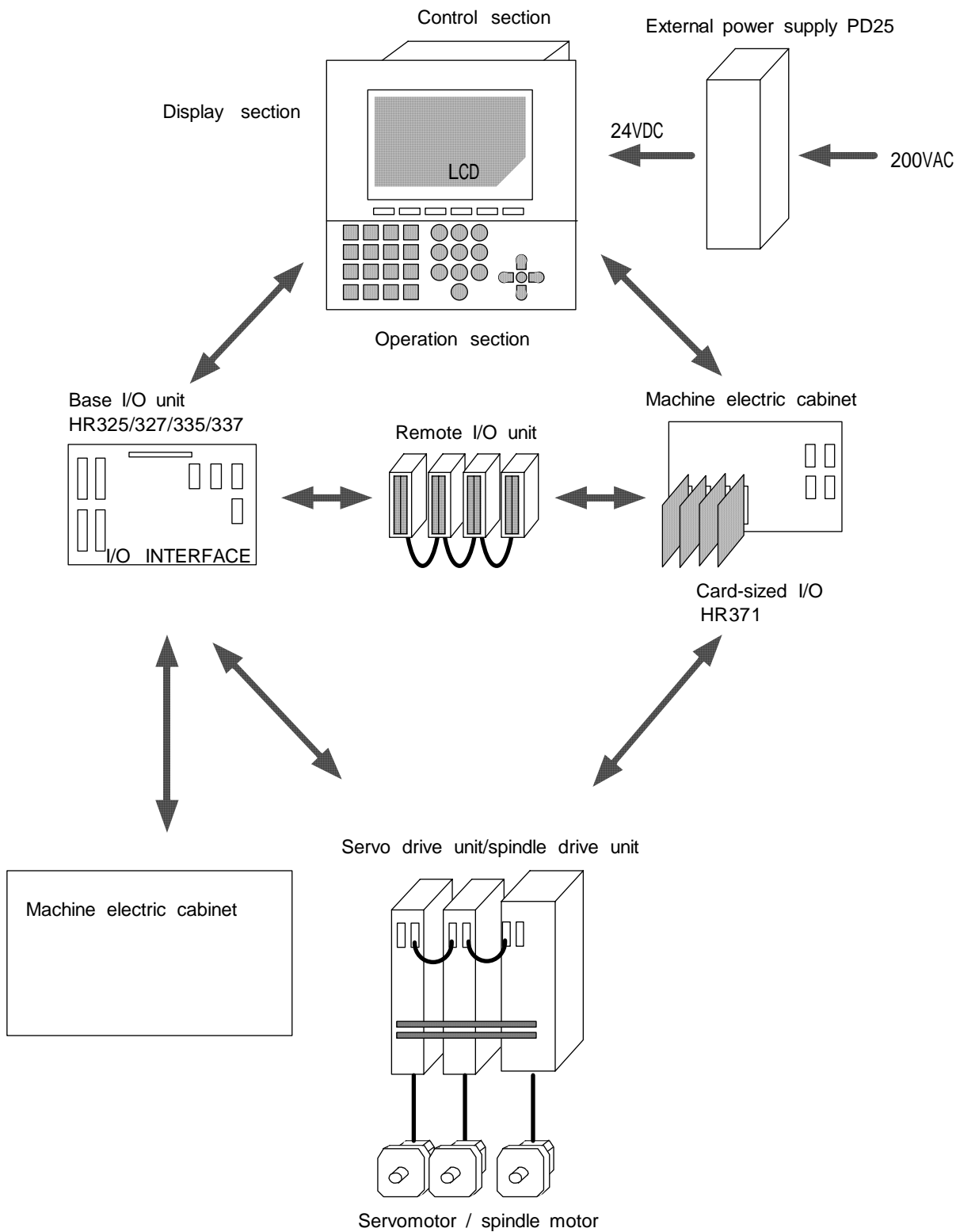

1. OUTLINE
1.1 System Configuration

1.1.3 Configuration

(1) Module configuration table

The M600 system is configured of the modules shown below.

No.	Type	Configuration module type	Function	Remarks
1	Control section 6MU001	HR111 card	Main CPU card	
		HR121 card	Man-machine interface card	
		HR081 card	Control power supply card	
		CARD PC	Man-machine	Mounted on HR121
		ER6 BKO-NC2157H01	Battery	Mounted on HR081
		MMF-04B05DM-R	DC fan	Mounted on HR111
		Chassis		Aluminum die cast
		Frame		Molded resin part
	Cover		Molded resin part	
2	Display section 6MB201	KCS6448HSTT-X3	LCD STN display	
		HR273 card	STN signal relay PCB	
		KCI-04	Backlight power supply	
		F082 cable	HR081- backlight power supply	
		F090 cable	HR121-HR273	
		F091 cable	HR273-LCD	
		F092 cable	HR273-LCD	
	KS-6MB201A-P	Menu keys		
	Escutcheon			
3	PCMCIA I/F 6PCM01	HR841 card	PCMCIA I/F	Built-in control section
		F150 cable	HR121-HR841	

1. OUTLINE
1.1 System Configuration

No.	Type	Configuration module type	Function		Remarks
4	HDD external unit FCU6-HD101 -1	MK1924FCV	Hard disk		
		F140 cable	HR121-HDD		
		External HDD installation fitting & cover	With heater		
	Damping rubber			4 pieces	
5	Single supply parts	PD25	External power supply		
		HR371 card	Card-sized I/O	Source method	Di: 16 points Do: 16 points
		HR325 card	Base I/O unit	Sink method	Di: 48 points Do: 48 points
		HR335 card		Sink method	Di: 64 points Do: 64 points
		HR327 card		Source method	Di: 48 points Do: 48 points
		HR337 card		Source method	Di: 64 points Do: 64 points
		FD-235HG-7332	Floppy disk		
	F130 cable	HR121-FDD			

1. OUTLINE
1.1 System Configuration

(2) Control section module configuration

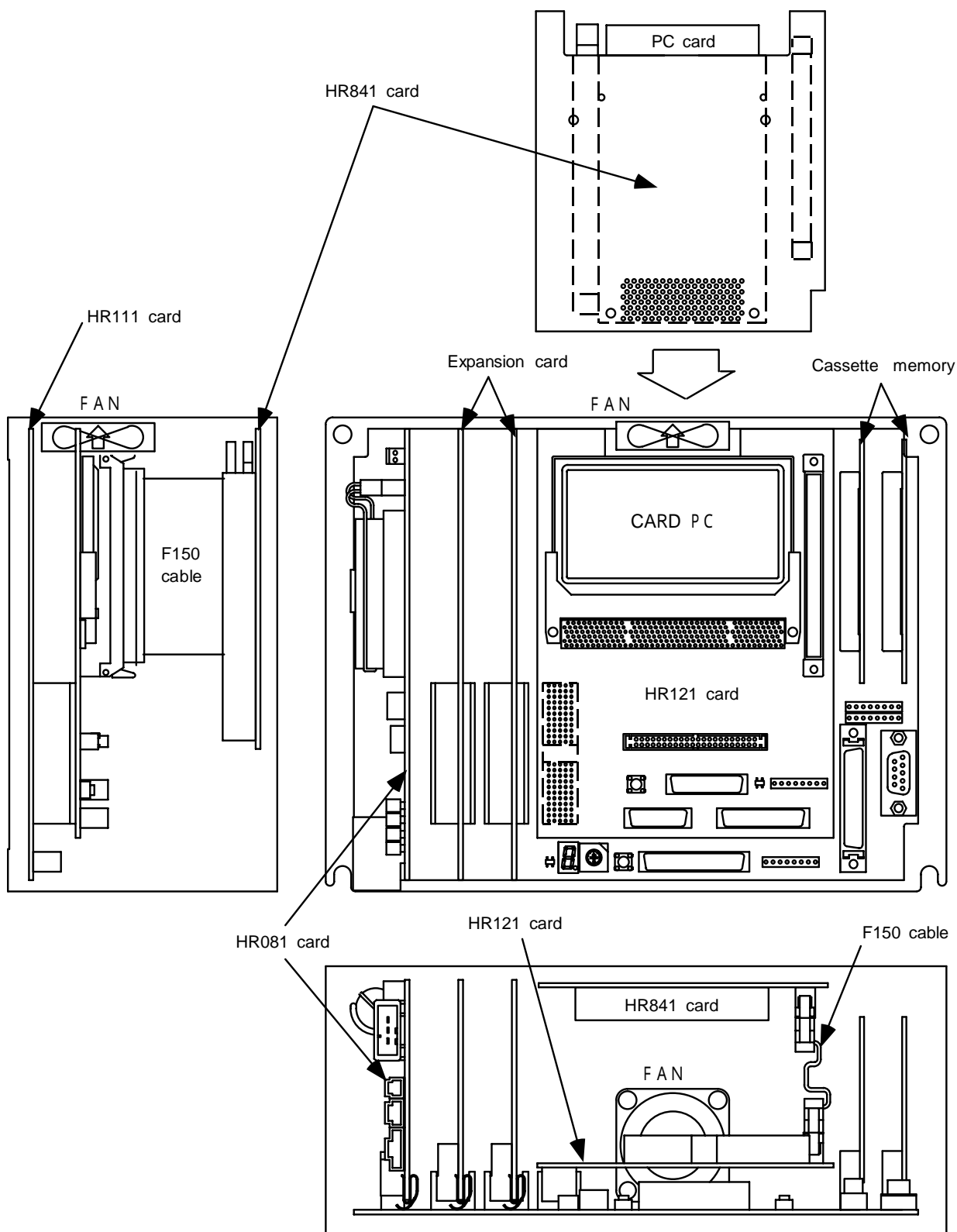

2. EXPLANATION OF MODULE FUNCTIONS
2.1 HR111 Card

2. EXPLANATION OF MODULE FUNCTIONS

2.1 HR111 Card

[Block diagram]

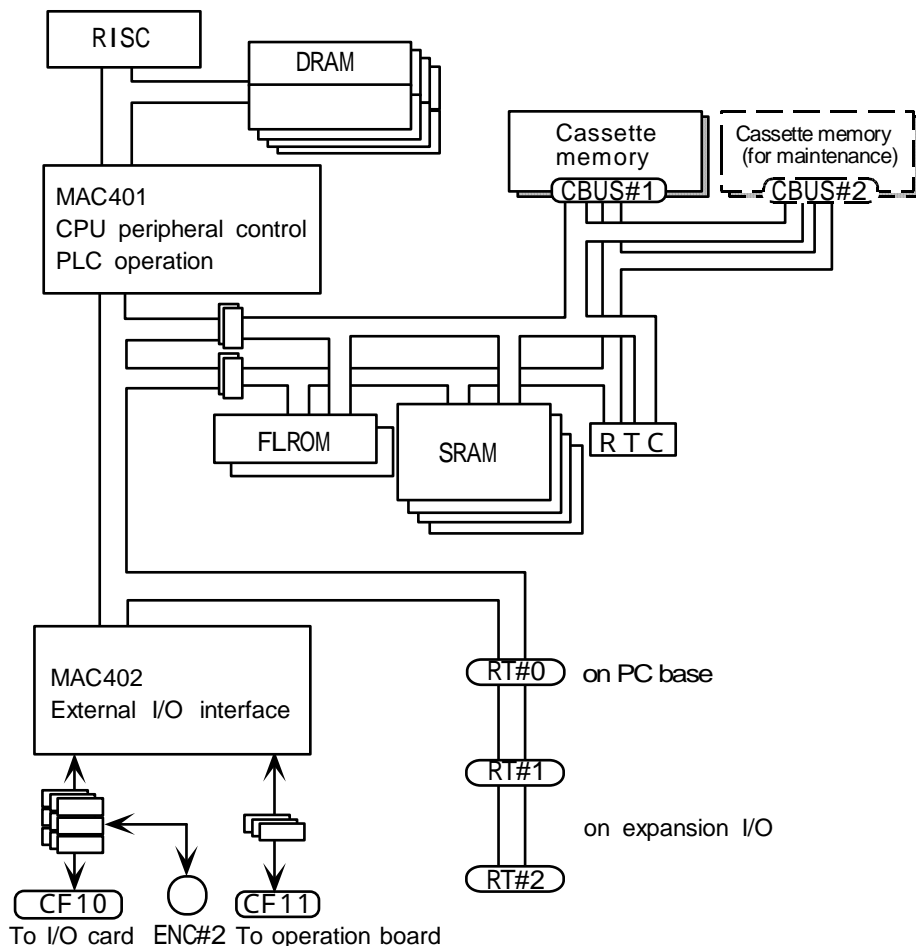

[Explanation of functions]

The HR111 card is the main CPU of the M600 system, and has the following functions.

CPU	64-bit RISC chip	
ASIC	CPU peripheral control & PLC operation (MAC401)	
	External I/O interface (MAC402)	
Memory	DRAM	For system working
	FLROM	For system ROM & boot ROM
	SRAM	For machining program and parameter backup
Cassette I/F	CBUS #1 connector	For cassette memory
	CBUS #2 connector	For cassette memory (for maintenance)
RT bus	RT #0 connector	For man-machine interface card (HR121)
	RT #1/#2 connector	For expansion card
I/O interface	CF10 connector	RIO 2ch, servo 2ch, encoder 1ch, skip 8 points
Power supply interface	AVR connector	For control power supply (HR081)
Operation board interface	CF11 connector	Key scan, RIO, handle 3ch, RS-232-C 2ch

2. EXPLANATION OF MODULE FUNCTIONS

2.1 HR111 Card

[Connector layout diagram]

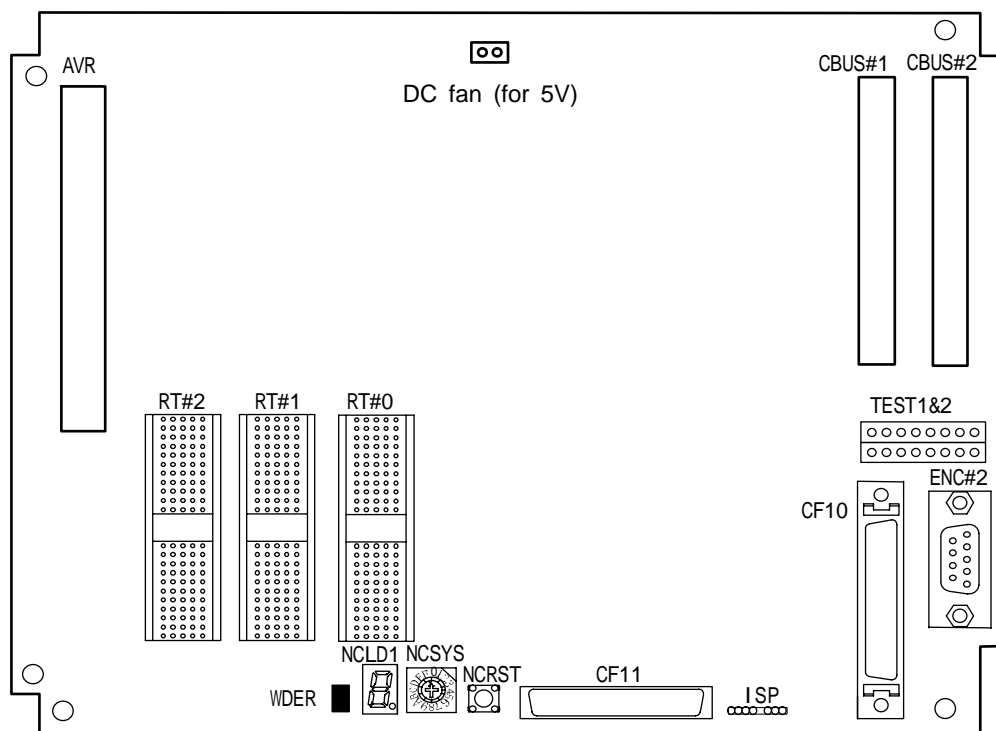

TEST 1 & 2 : Test pins for maintenance and service
 NCREST : NC reset (do not press during normal system operation)

[Explanation of settings]

NCSYS: System mode selection rotary switch

Switch	Mode	Details
0	Standard mode	Operation of system 1
1	PLC stop	The system is started while the PLC is stopped.
2	Maintenance mode	
3		
4		
5		
6		
7	SRAM mode	The system parameter area is cleared.
8	Maintenance mode (The cassette memory must be connected to the CBUS #2 connector.)	
9		
A		
B		
C		
D		
F		

[Explanation of LEDs]

NCLD1: 7-segment system status display LED
 WDER : Watch dog error LED (red) Refer to section 3.1 for details.

2. EXPLANATION OF MODULE FUNCTIONS
2.2 HR121 Card

2.2 HR121 Card

[Block diagram]

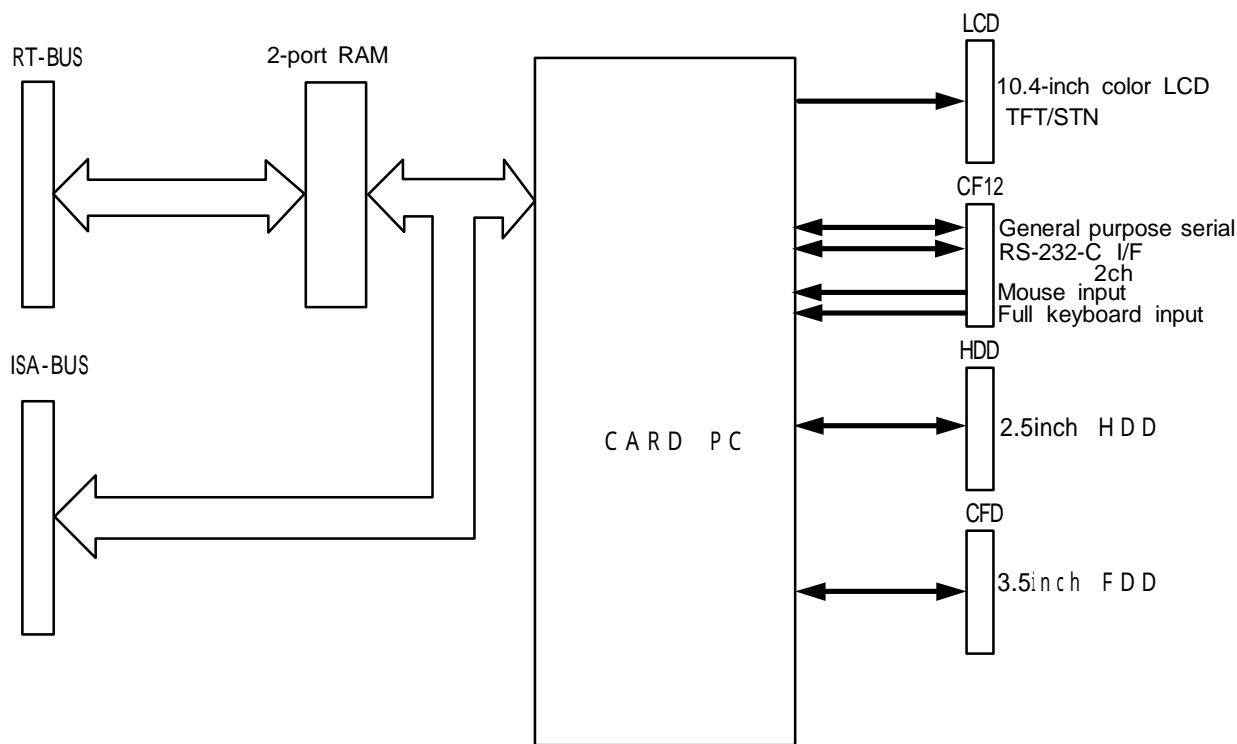

[Explanation of functions]

The HR121 card is the man-machine interface for the M635/M655 system, and has the following functions.

2-port RAM		For data transmission/reception
Card PC I/F	CARDPC connector	For the card PC
ISA bus I/F	ISA connector	For PCMIA card HR841 connection
Floppy disk I/F	CFD connector	For 3.5-inch FDD connection
Hard disk I/F	HDD connector	For 2.5-inch HDD connection
General purpose serial I/F	CF12 connector	RS-232-C specifications: 2ch
Mouse input I/F	CF12 connector	PS/2 compatible
Full keyboard I/F	CF12 connector	PS/2 compatible
Display output I/F	LCD connector	For 10.4-inch color LCD TFT/STN
RTBUS I/F	RTBUS connector	For HR111 card connection

2. EXPLANATION OF MODULE FUNCTIONS

2.2 HR121 Card

[Connector layout diagram]

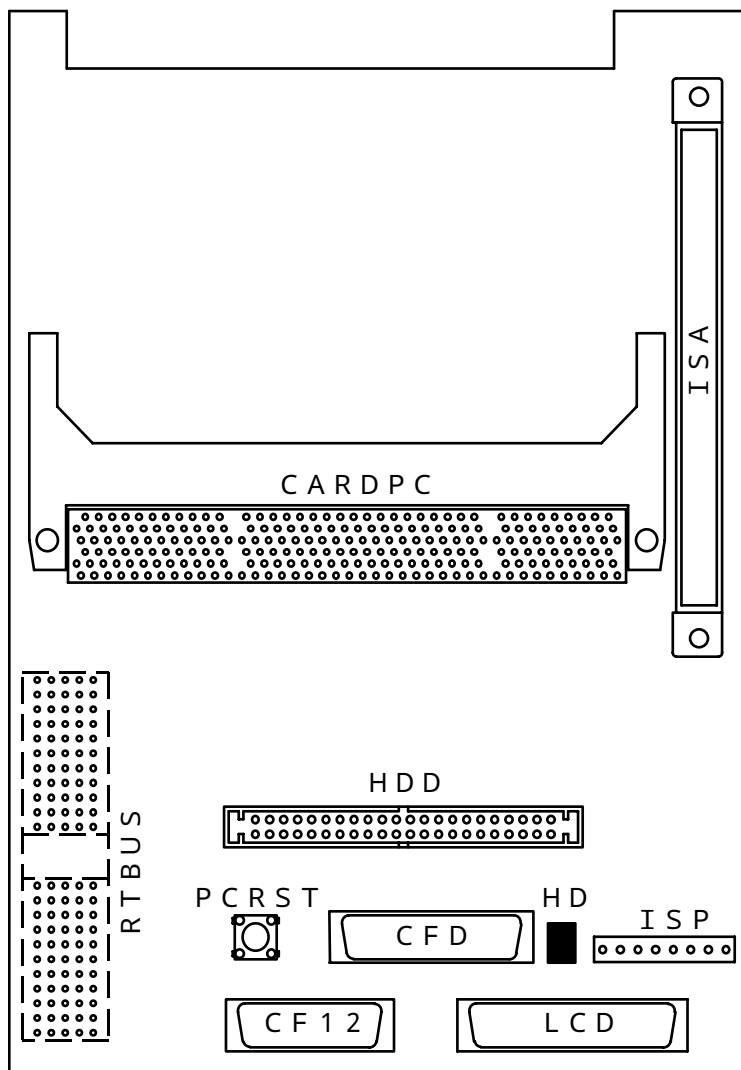

PCRST: Personal computer reset push-button switch

[Explanation of LEDs]

HD: Accessing hard disk LED (green) Refer to section 3.1 for details.

2. EXPLANATION OF MODULE FUNCTIONS

2.3 HR081 Card

2.3 HR081 Card

[Block diagram]

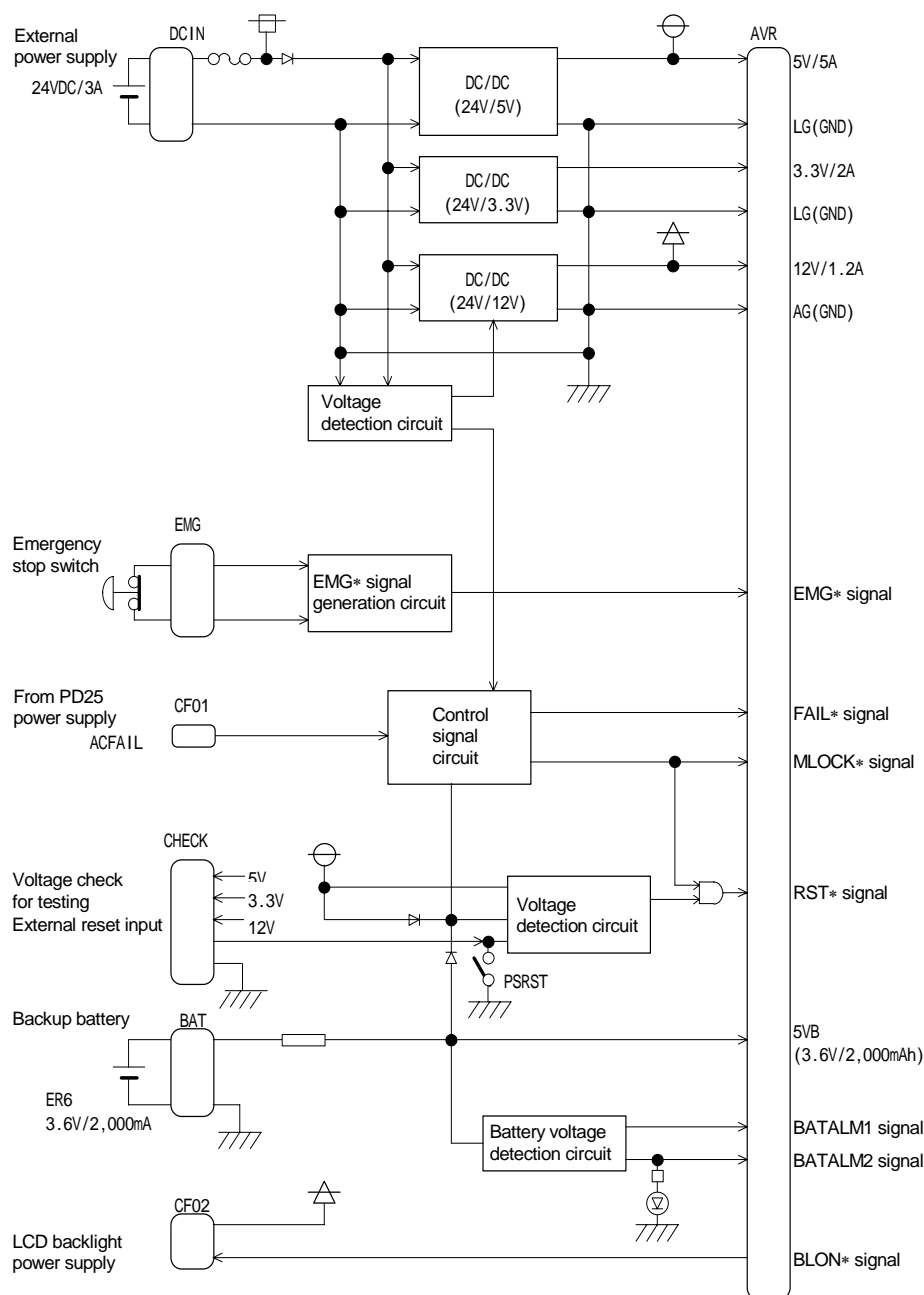

[Explanation of functions]

The HR081 card is the multi-power supply for the M600 system, and has the following specifications.

Input voltage/current	24VDC \pm 5% : 3A	DCIN connector
Output voltage/current	3.3VDC:2A/5VDC:5A/12VDC:1.2A	AVR connector
Input control signal	Emergency stop switch signal	EMG connector
	ACFAIL signal	CF01 connector
	Backup battery (lithium battery 3.6VDC: 2000mAh)	BAT connector
	External reset signal	CHECK connector
Output control signal	Backlight ON/OFF, backlight power supply, brightness	CF02 connector
	Fan power supply (24VDC: 120mA)	FAN connector (not used)
	Output voltage monitor	CHECK connector

2. EXPLANATION OF MODULE FUNCTIONS

2.3 HR081 Card

[Connector layout diagram]

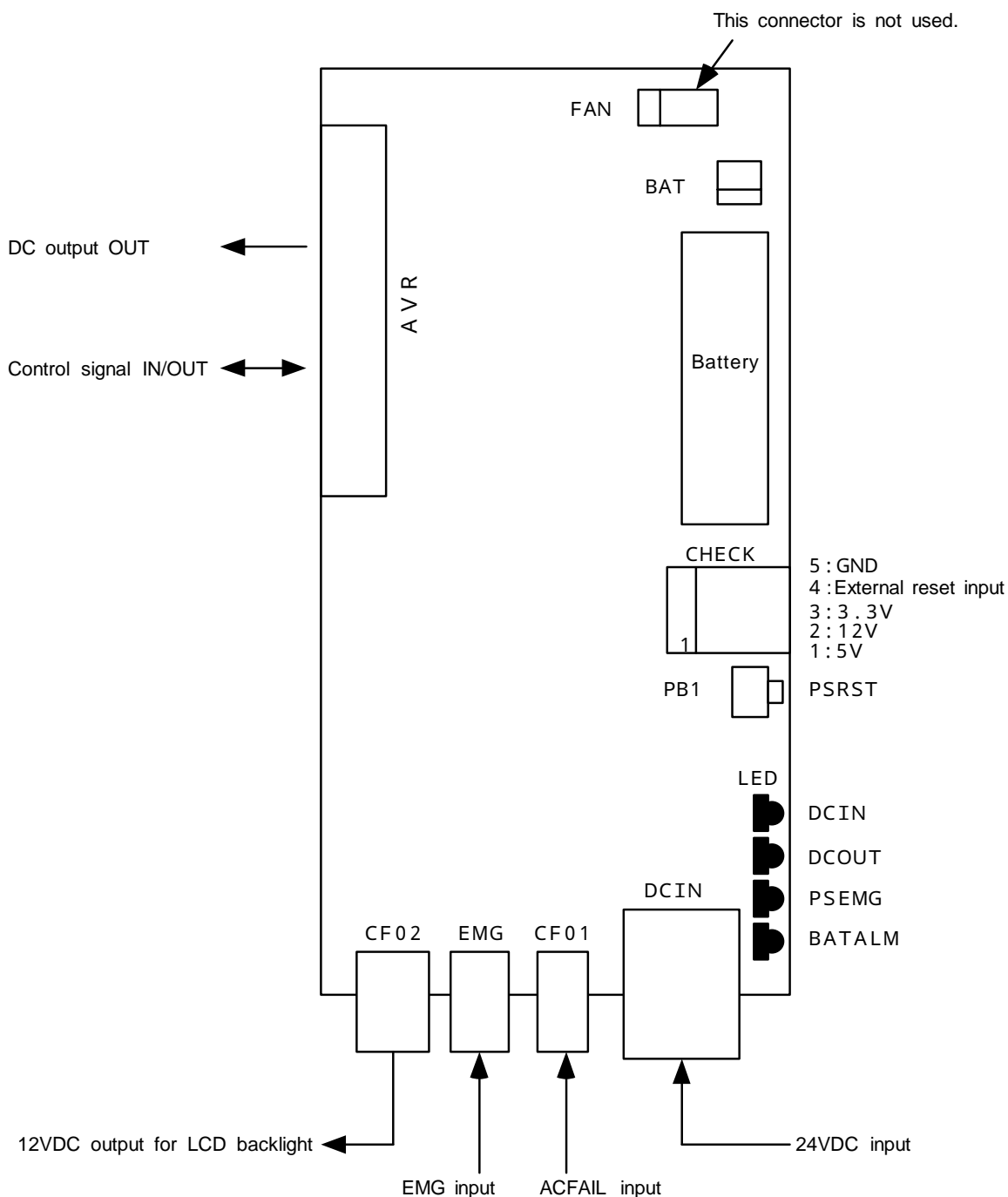

PSRST: System reset (do not press during normal system operation)

[Explanation of LEDs]

- DCIN : LED lit during 24VDC supply (green)
 - DCOUT : LED lit during internal power supply output (green)
 - PSEMG : Power supply emergency stop (red)
 - BATALM : Battery drop warning (red)
- } Refer to section 3.1 for details.

2. EXPLANATION OF MODULE FUNCTIONS
2.4 HR841 Card

2.4 HR841 Card

[Block diagram]

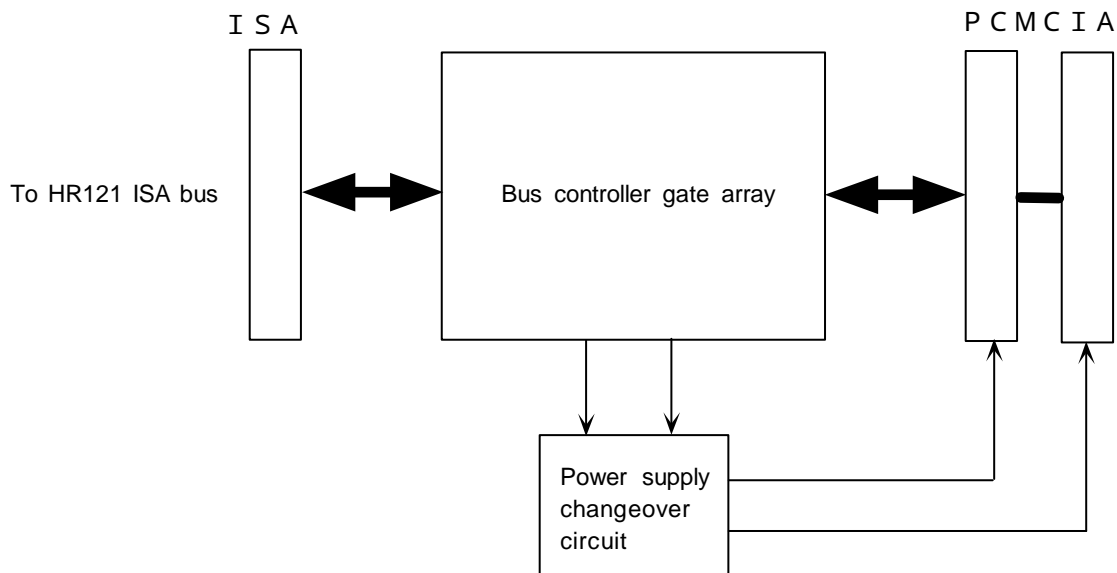

[Explanation of functions]

The HR841 card is an interface with the M635 /M655 system's IC memory card, I/O card and ISA bus that comply with the PCMCIA (Personal Computer Memory Card International Association) 2.1 and JEIDA 4.2 standards.

ISA bus → PCMCIA conversion : bus controller gate array
 IC card slot : 2 slots

[Connector layout diagram]

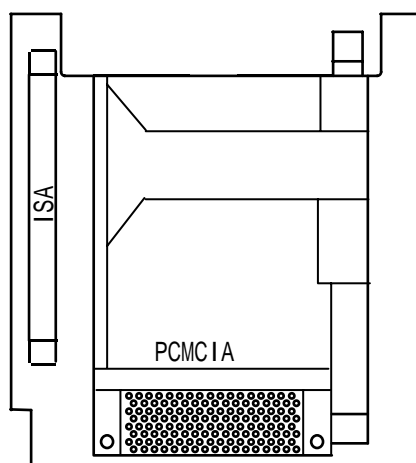

<Specifications of card corresponding with PCMCIA slot>

- 1) Limited to 5V specification products. (3.3V specifications cannot be used.)
- 2) The max. current consumption is limited to 1A/slot.
- 3) Mitsubishi Electric recommended IC card

2. EXPLANATION OF MODULE FUNCTIONS
2.5 HR273 Card

2.5 HR273 Card

[Block diagram]

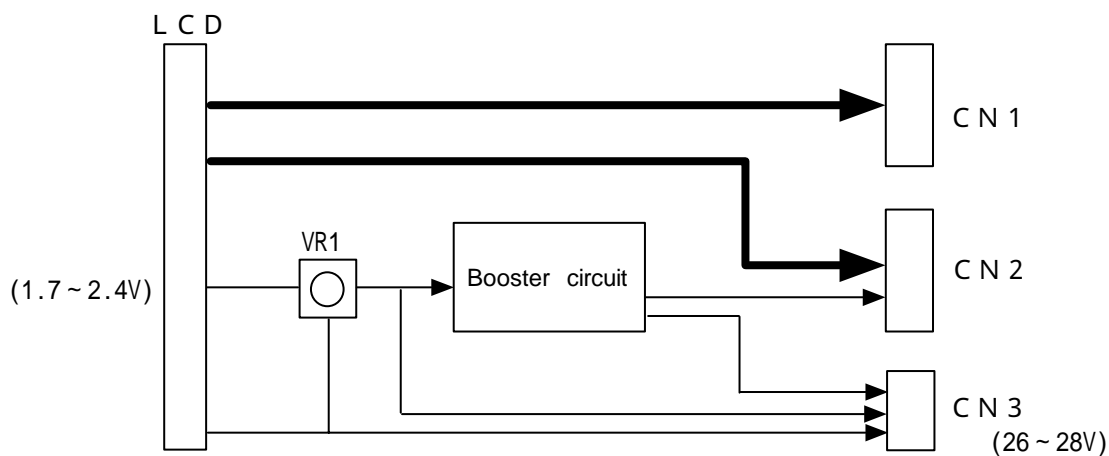

[Explanation of functions]

The HR273 card is the interface for the STN-LCD signals of the M600 system, and has the following specifications.

Voltage booster circuit
STN-LCD signal

Contrast voltage
LCD connector
CN1/CN2 connector
CN3 connector
VR1

Input: 1.7 to 2.4V, Output: 26 to 28V
HR121 side
STN-LCD side

Contrast voltage output
Contrast voltage fine
adjustment potentiometer

The contrast voltage has been set before shipment, and thus does not require adjustment.

The contrast can be adjusted from the keyboard on the display screen. If the display does not appear, turn the potentiometer to the left and right to confirm the screen.

[Connector layout diagram]

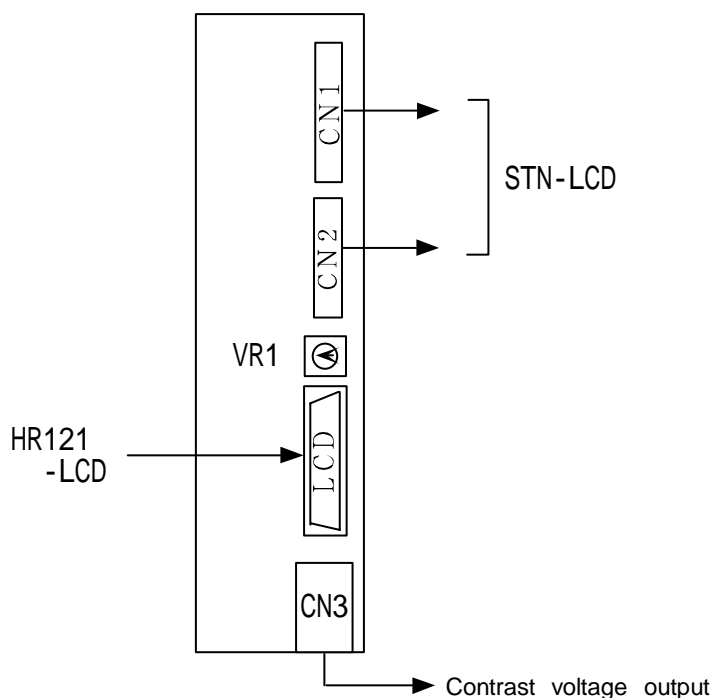

2. EXPLANATION OF MODULE FUNCTIONS
2.6 HR371 Card

2.6 HR371 Card

[Block diagram]

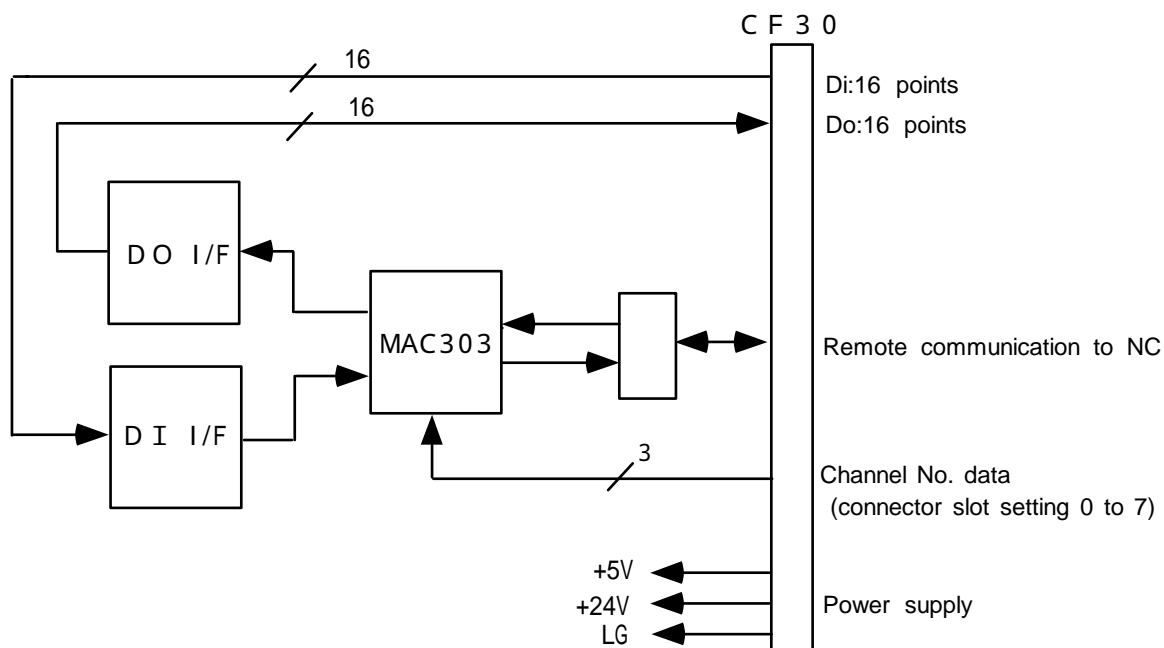

[Explanation of functions]

The HR371 card is the source specification card-sized I/O for the M600 system. This card is used while connected to the machine electric cabinet.

Up to eight remote cards can be connected per system. The functions for each card are as follow.

MAC303	Remote I/O controller	} CF30 connector
Channel No. data	The channel No. can be set between 0 and 8 with the level information of the three pins from the connection designation.	
Machine input interface	16-point insulated type	
Machine output interface	16-point non-insulated type	
Power supply	24VDC±5%/5VDC±5%	

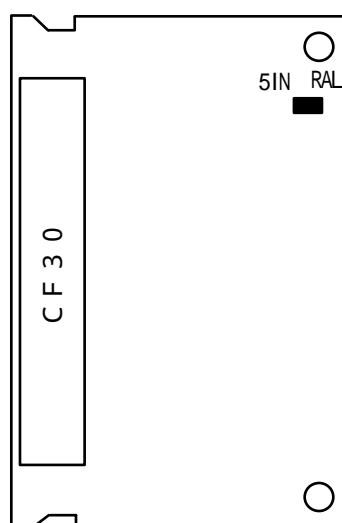

[Explanation of LEDs]

5IN (left side) : LED lit during 5VDC circuit power supply (green)

RAL (right side) : Remote communication alarm (red) Refer to section 3.1 for details.

2. EXPLANATION OF MODULE FUNCTIONS
2.7 HR325, 327, 335, 337 Cards

2.7 HR325, 327, 335, 337 Cards

[Block diagram]

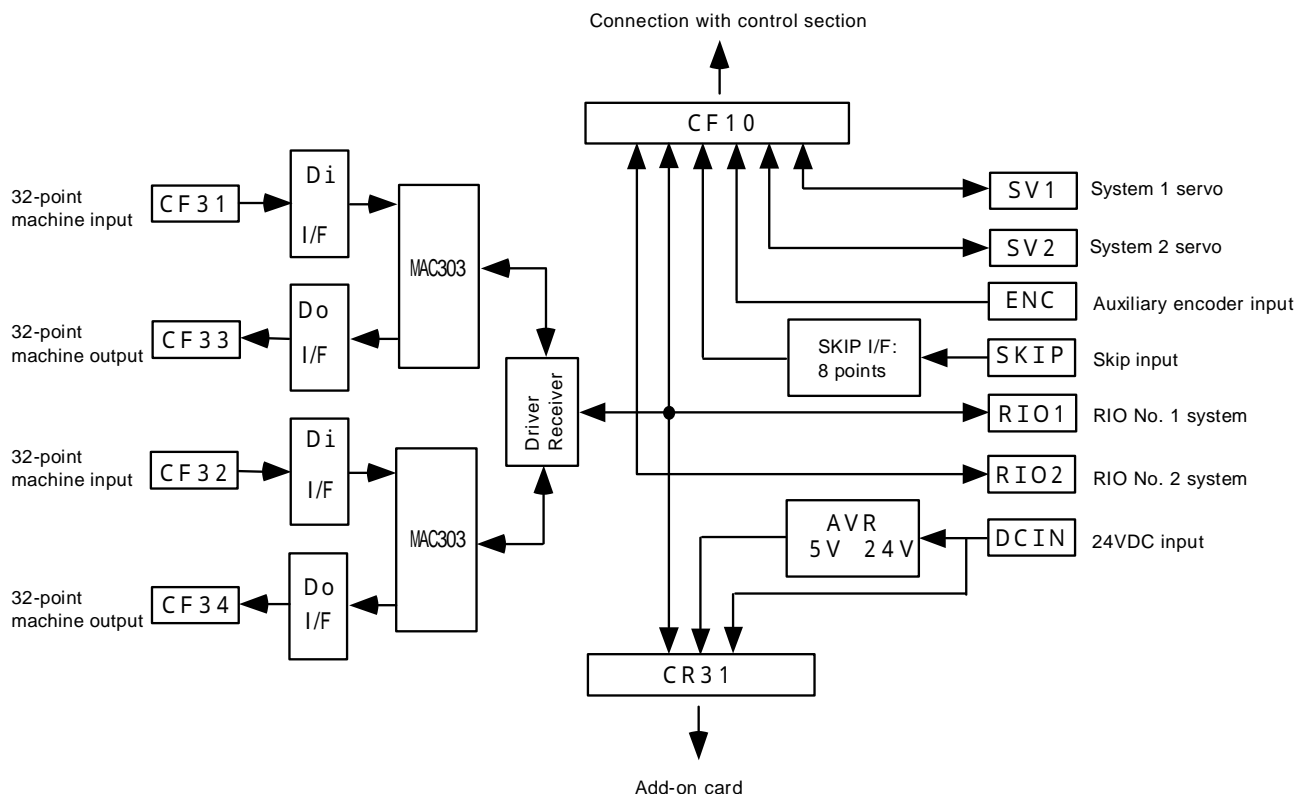

[Explanation of functions]

The HR325, 327, 335, 337 cards are the base I/O units for the M600 system. These are used as a one-on-one connection with control section. The HR325 and 327 have the sink specifications, and the HR335 and 337 have the source specifications. The card with 5 as the last digit have a 48-point machine input and 48-point machine output. The functions are as follow.

MAC303	Remote I/O controller	Occupies 2 channels (Connected to RIO NO. 1 system)
Remote I/F channel No. setting	RIO1, 2 connector	Max. 8 channels for each of the two systems. Set with the rotary switches CS1 and CS2.
Machine input interface	CF31/32 connector	Insulated type HR325/335: 48 points HR327/337: 64 points
Machine output interface	CF33/34 connector	Non-insulated type HR325/335: 48 points HR327/337: 64 points
Skip input I/F relay plug	SKIP connector SV1, SV2 connector ENC1 connector	Insulated type: 8 points Servo amplifier connection: 2 systems Auxiliary encoder connection: 1 ch
Add-on card I/F	CR31 connector	RX32O card connection is possible
Power supply	24VDC±5%:6Amax	When using machine output: 60mA/point

2. EXPLANATION OF MODULE FUNCTIONS
2.7 HR325, 327, 335, 337 Cards

[Connector layout diagram]

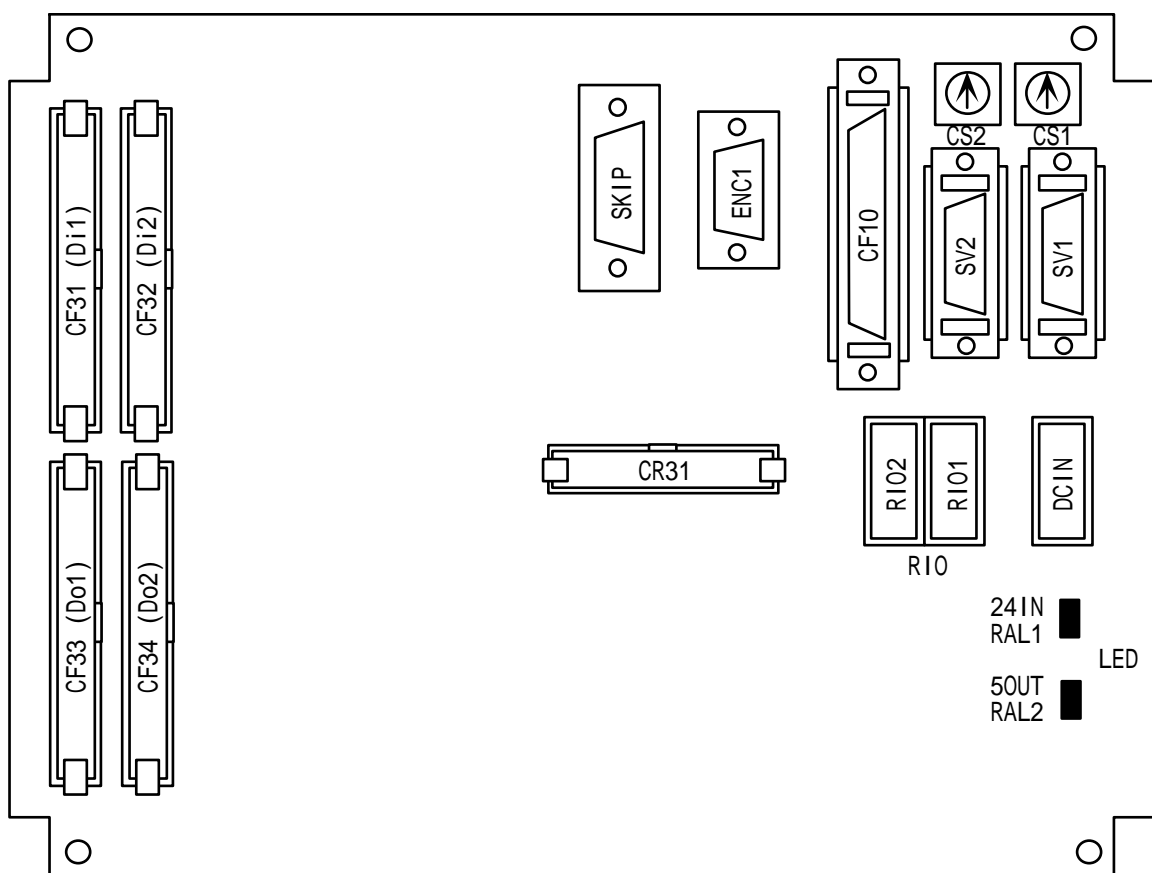

[Explanation of settings]

CS1: Onboard RIO No. 1 channel No. setting rotary switch

CS2: Onboard RIO No. 2 channel No. setting rotary switch

<Setting method>

0 to 7 : Corresponds to channel Nos. 0 to 7

8 and following : Loop back test mode (for testing)

* The CS1 and CS2 settings must always be different for the HR325, 327, 335 and 337 cards.

Always set different channel Nos. for each remote unit and add-on card connected to the same system. Up to eight channels can be set per system.

[Explanation of LEDs]

24IN (upper side) : LED lit during supply of 24VDC (green)

50UT (upper side) : LED lit during output of 5VDC circuit power (green)

RAL1 (lower side) : Onboard RIO No. 1 channel communication alarm (red)

RAL2 (lower side) : Onboard RIO No. 2 channel communication alarm (red)

} Refer to section 3.1 for details.

2. EXPLANATION OF MODULE FUNCTIONS

2.8 Floppy Disk

2.8 Floppy Disk

The FDD used in the M600 system has the following specifications. This FDD is compatible with the 2HD (2MB/1.6MB) and 2DD (1MB) recording types.

[FD-235HG-7332 specifications]

Applicable safety standards	UL, CAS, TUV		
Operation mode	2MB mode recording/play	1.6MB mode recording/play	1MB mode recording/play
Applicable disk (3.5-inch)	High density (2HD)	High density (2HD)	Normal density (2DD)
Unformatted data capacity	2M byte	1.6M byte	1M byte
Working power supply	Single-phase 5V [4.5 to 5.5V]		

[Setting layout]

The settings of the FDD must be changed according to the mode being used. The settings for each mode are explained below.

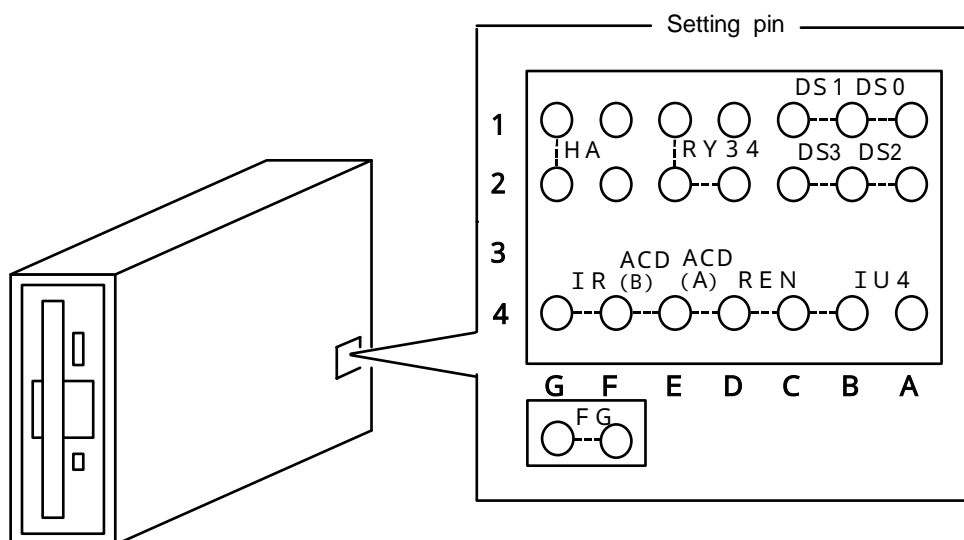

Setting name	Function
HA	1MB mode automatic setting (this is always ON in the 3-mode specifications)
RY34	READY output enable
DC34	DISK CHANGE output enable
DS0	DRIVE SELECT 0 input enable
DS1	DRIVE SELECT 1 input enable
DS2	DRIVE SELECT 2 input enable
DS3	DRIVE SELECT 3 input enable
IR	LED lighting conditions : DRIVE SELECT *READY state
ACD	Automatic chucking disable
REN	Automatic recalibration
IU4	IN use input enable
FG	Logic GND

[Explanation of settings]

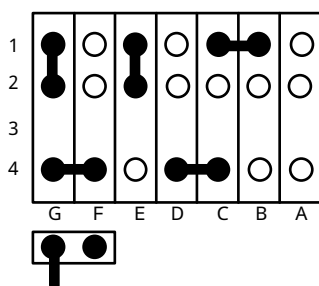

3. TROUBLESHOOTING

3.1 List of Unit LEDs

3. TROUBLESHOOTING

3.1 List of Unit LEDs

(1) NC control section

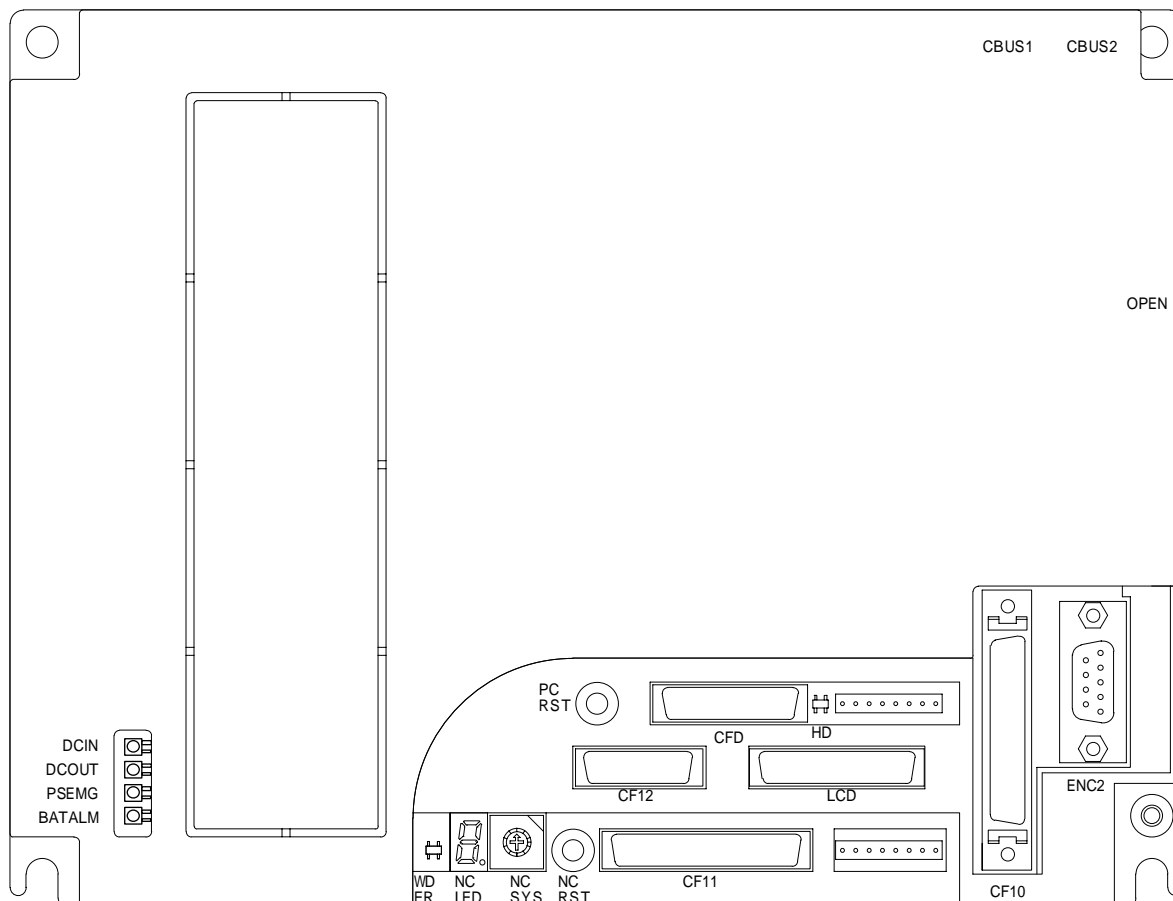

[Explanation of LED functions]

Name	Function	Color	Status		Correspondence for error
			When normal	During error	
DCIN	During 25VDC supply	Green	Lit	Not lit	Refer to section 3.2.2 (1)
DCOUT	During internal power output	Green	Lit	Not lit	
PSEMG	Power supply emergency stop	Red	Not lit	Lit	Refer to section 3.2.2 (1)
BATALM	Battery drop warning	Red	Not lit	Lit	Refer to section 4.3.2 (1)
WDER	Watch dog alarm	Red	Not lit	Lit	Refer to section 3.2.2 (5)
NCLED	7-segment system status display		According to system state		
HD	Accessing hard disk	Green	Flickers during access		Refer to section 3.2.2 (4)

3. TROUBLESHOOTING

3.1 List of Unit LEDs

(2) Base I/O unit, card-sized I/O

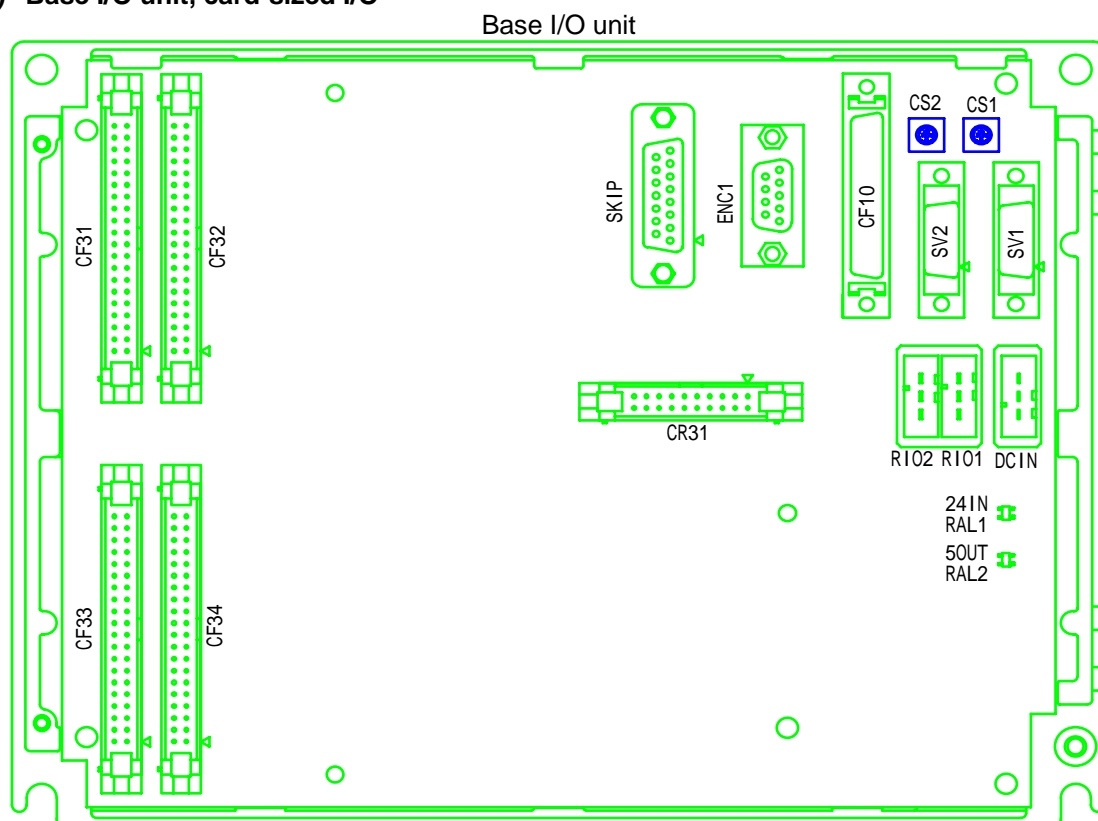

Card-sized I/O

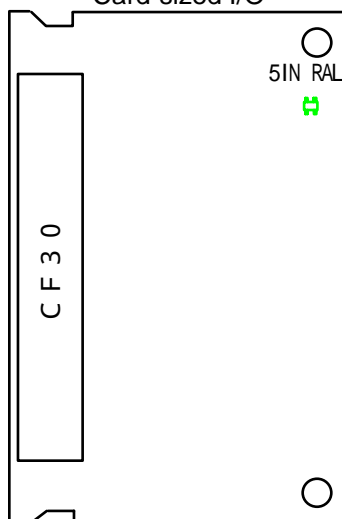

[Explanation of LED functions]

Name	Function	Color	Status		Correspondence for error
			When normal	During error	
24IN	During 24VDC input supply	Green	Lit	Not lit	Refer to section 3.2.2 (7)
5OUT	During 5VDC circuit power output	Green	Lit	Not lit	
RAL1	Onboard I/O No. 1 channel communication alarm	Red	Not lit	Lit	
RAL2	Onboard I/O No. 2 channel communication alarm	Red	Not lit	Lit	
5IN	During card-sized I/O 5VDC input supply	Green	Lit	Not lit	5VDC \pm 5% voltage supply
RAL	Card-sized I/O communication alarm	Red	Not lit	Lit	Refer to section 3.2.2 (7)

3. TROUBLESHOOTING

3.2 Troubleshooting

3.2 Troubleshooting

3.2.1 Confirmation of trouble state

Confirm "when", "when doing what", and "what kind of" trouble occurred.

(1) When?

What time did the trouble occur?

(2) When doing what?

What was the NC operation mode?

- During automatic operation Program No., sequence No. and program details when the trouble occurred.
- During manual operation What was the manual operation mode?
What was the operation procedure?
What were the previous and next steps?
- What was the setting and display unit screen?
- Did the trouble occur during input/output operations?
- What was the machine side state?
- Did the trouble occur while replacing the tools?
- Did hunting occur in the control axis?

(3) What kind of trouble?

- What was displayed on the setting and display unit's Alarm Diagnosis screen?
Display the Alarm Diagnosis screen, and check the alarm details.
- What was displayed for the machine sequence alarm?
- Is the LCD screen normal?

(4) How frequently?

- When did the trouble occur? What was the frequency? (Does it occur when other machines are operating?) If the trouble occurs infrequently or if it occurs during the operation of another machine, there may be an error in the power voltage or the trouble may be caused by noise, etc. Check whether the power supply is normal (does it drop momentarily when other machines are operating?), and whether noise measures have been taken.
- Does the trouble occur during a specific mode?
- Does the trouble occur when the overhead crane is operating?
- What is the frequency in the same workpiece?
- Check whether the same trouble can be repeated during the same operation.
- Check whether the same trouble occurs when the conditions are changed. (Try changing the override, program details, and operation procedures, etc.)
- What is the ambient temperature?
(Was there a sudden change in the temperature? Was the fan at the top of the control unit rotating?)
- Is there any contact defect or insulation defect in the cables?
(Has any oil or cutting water splattered onto the cables?)

3. TROUBLESHOOTING

3.2 Troubleshooting

3.2.2 When in trouble

If the system does not operate as planned or if there is any trouble in the operation, confirm the following points and then contact the Mitsubishi Service Center.

– Examples of trouble –

- The power is not ON.
- The power turns OFF.
- The screen does not appear.
- The operation keys do not function.
- The HDD does not function.
- The FDD does not function.
- Machining is not possible.

[Precautions]

If the outdoor temperature is 5°C or less, the NC may not start up. However, warmup operation is carried out by warming up the HDD with the heater to protect the HDD from low temperatures. Check the warmup operation sign with the LEDs on the operation board. (Refer to the operation board manual issued by each machine maker.)

The NC will start up automatically when the warmup operation is completed.





3. TROUBLESHOOTING

3.2 Troubleshooting

(1) Problems related to the power supply

The power does not turn ON.	
Cause	Remedy
The power cord is disconnected or loose.	Check the cable between the NC unit and the external power supply, and between the external power supply and socket. Make sure that the cable is inserted securely. Check that there are no wires broken in the cable. If broken, replace the cable.
The door interlock is applied.	If the control panel door is not completely closed, close it. If the door interlock is applied even when the door is closed, the door interlock circuit is damaged. Repair it.
There is a problem in the power socket.	If the socket has a switch, turn the switch ON. Make sure that the specified power voltage and power frequency is being output from the socket.
The external power supply is faulty.	Check that the power can be turned ON with just the external power supply. Note) Depending on the external power supply being used, the power may not turn ON in the no-load state, so install a slight load and check.
The ON/OFF cable is short circuited.	Disconnect the ON/OFF cable and check that it is not short circuited. If short circuited, replace the cable.
The external power supply's input voltage is not as specified.	Check that the input voltage is within 200 to 230VAC ⁺¹⁰ ₋₁₅ %.
The external power turns ON but the NC control power does not turn ON.	
Cause	Remedy
The external power supply output is not correct.	Disconnect the cable between the NC unit and the external power supply, and check that the external power supply output is normal. Wire the cable between the NC unit and external power supply, and check that the external power supply output is normal.
The cable connected from the NC unit to the peripheral device is short circuited.	Disconnect the cable connected to the peripheral device one at a time and check that the power turns ON. Check that there are no short-circuited cables.
There is a short circuit in the configuration card.	Remove the removable cards one at a time and check that the power turns ON. Check that there are no short-circuited cards. Refer to section 4.3.3 for the removable cards.

CAUTION

-  Do not apply voltages other than those indicated in this manual on the connector. Doing so may lead to destruction or damage.
-  Incorrect connections may damage the devices, so connect the cables to the specified connectors.
-  Do not connect or disconnect the connection cables between each unit while the power is ON.
-  Do not connect or disconnect the PCBs while the power is ON.

3. TROUBLESHOOTING





3.2 Troubleshooting

The power turns OFF.	
Cause	Remedy
There is a problem in the power socket.	Check whether the voltage fluctuates at certain time zones. Check whether an instantaneous power failure has occurred.
A problem occurs when the peripheral device starts operating.	Check whether the voltage drops instantaneously when the peripheral device operation starts.
The PSEMG (red) LED on the HR081 card lights.	
Cause	Remedy
The emergency stop switch connected to the EMG connector is ON (A contact), or the EMG connector is disconnected.	Set the emergency stop switch to the release (B contact) state. Check the connection to the EMG connector.
The BATALM (red) LED on the HR081 card lights.	
Cause	Remedy
The LED lights when the voltage of the battery connected to the HR81 BAT connector has dropped to $2.6V \pm 0.065V$ or less.	Refer to section 4.3.2 (2) and replace the battery.

(2) Problems related to display section

The LCD screen does not appear.	
Cause	Remedy
The power is not supplied to the backlight power for the display section.	Check that the F082 cable is connected to the control section's power supply HR081 CF02 connector and backlight power.
The connection from the LCD display to the backlight power is disconnected.	Check that the wiring from the LCD display is connected to the backlight power.
The F090 cable is not connected to the HR121 card LCD connector and HR273 card LCD connector.	Check that the F090 cable is connected.
The connection from the HR273 card and the LCD display is disconnected.	Check that the wiring from the LCD display is connected to the HR273 card.
The LCD display, backlight power or HR121 card is damaged.	Check the cable connections. If normal, the individual module may be damaged. Contact the Mitsubishi Service Center.

CAUTION

-  Do not apply voltages other than those indicated in this manual on the connector. Doing so may lead to destruction or damage.
-  Incorrect connections may damage the devices, so connect the cables to the specified connectors.
-  Do not connect or disconnect the connection cables between each unit while the power is ON.
-  Do not connect or disconnect the PCBs while the power is ON.

3. TROUBLESHOOTING

3.2 Troubleshooting

The LCD display is dark and the characters are not visible. The display is light and the characters are not visible.	
Cause	Remedy
The contrast voltage is not correctly adjusted.	Turn the contrast voltage fine adjustment potentiometer VR1 on the HR273 card, mounted on the rear of the display, to the left and right, and check that the screen appears correctly.
The LCD screen characters are light and hard to read.	
Cause	Remedy
The LCD contrast deviated due to changes in the ambient temperature.	Adjust the contrast on the display's contrast adjustment screen.
The LCD screen is disturbed and cannot be synchronized, or the characters are unrecognizable.	
Cause	Remedy
The card PC or HR121 card is damaged.	Contact the Mitsubishi Service Center.

(3) Problems related to operation section

A specific key switch does not function.	
Cause	Remedy
All key inputs do not function.	
Cause	Remedy
The F050 cable connected between the operation section key switches and the control section is disconnected.	Check the F050 cable connection.
The circuit in the HR111 card is faulty.	Contact the Mitsubishi Service Center.
The action differs from the operation.	
Cause	Remedy

CAUTION

- Do not apply voltages other than those indicated in this manual on the connector. Doing so may lead to destruction or damage.
- Incorrect connections may damage the devices, so connect the cables to the specified connectors.
- Do not connect or disconnect the connection cables between each unit while the power is ON.
- Do not connect or disconnect the PCBs while the power is ON.

3. TROUBLESHOOTING

3.2 Troubleshooting





(4) Problems related to HDD

The message "Non System Disk Error" appears when the system is started.	
Cause	Remedy
The HDD connection connector is disconnected.	Check the connection state of the HDD cable F140.
When the FDD was connected, a disk other than the system disk was inserted.	Remove the disk from the FDD and restart.
If the heat up lamp on the operation section is lit, the warmup operation to protect against low temperatures is being carried out.	Wait for the HDD warmup operation to be completed.
When none of the above causes apply:	Contact the Mitsubishi Service Center.

(5) Problems when starting the system

The NC does not start up correctly.	
Cause	Remedy
8 is displayed on the HR111 card's 7-segment display NCLD1.	Check that the rotary switch NCSYS is set to 0.
E or F is displayed on the HR111 card's 7-segment display NCLD1.	Contact the Mitsubishi Service Center.

CAUTION

-  Do not apply voltages other than those indicated in this manual on the connector. Doing so may lead to destruction or damage.
-  Incorrect connections may damage the devices, so connect the cables to the specified connectors.
-  Do not connect or disconnect the connection cables between each unit while the power is ON.
-  Do not connect or disconnect the PCBs while the power is ON.





3. TROUBLESHOOTING

3.2 Troubleshooting

(6) Problems related to remote I/O

The communication alarm LED RAL is lit.	
Cause	Remedy
The remote connection cable is not connected. The cable has broken wires or the contact is defective.	Check the connection of the remote connection cable F010 with the NC control section or the cable SH41 between the remote I/Os.
The HR300 card is defective.	Contact the Mitsubishi Service Center, and then replace the card.
The power supply system LED is not lit.	
Cause	Remedy
The 24IN LED is not lit. (The input power is not being supplied.)	Supply a +24V ± 5% voltage to the HR300 card.
The 5OUT LED is not lit. (The input power is not within the tolerable range, or the internal power is faulty.)	Check that the input voltage is not +20 V or less. If it is being supplied correctly, contact the Mitsubishi Service Center.

 **CAUTION**

-  Do not apply voltages other than those indicated in this manual on the connector. Doing so may lead to destruction or damage.
-  Incorrect connections may damage the devices, so connect the cables to the specified connectors.
-  Do not connect or disconnect the connection cables between each unit while the power is ON.
-  Do not connect or disconnect the PCBs while the power is ON.

4. DAILY MAINTENANCE AND PERIODIC INSPECTION AND MAINTENANCE
4.1 Maintenance Tools

4. DAILY MAINTENANCE AND PERIODIC INSPECTION AND MAINTENANCE

4.1 Maintenance Tools

(1) Measuring instruments

The following measuring instruments are used to confirm that the voltage is being supplied correctly to the NC unit, to confirm that the wiring to the NC unit is correct, and to carry out simple troubleshooting.

Table 4.1 Maintenance tools

Tool	Condition	Application
Tester		To check that the wiring to the NC unit is correct before turning the power ON.
AC voltmeter	Measure the AC power voltage. The tolerable error is $\pm 2\%$ or less.	To measures the AC power voltage being supplied to the external 24VDC power supply unit.
DC voltmeter	Max. scale 30V. The tolerable error is $\pm 2\%$ or less.	To measure the DC power voltage. External power supply 24V (control section, machine input/output interface) Battery voltage HR081 DC output
Phase rotation meter		To check the connection order of the AC 3-phase input power supply.
Synchroscope		General measurement and simple troubleshooting

Note 1) Currently, a high precision digital multi-meter is commonly used as a tester. This digital multi-meter can be used as both an AC voltmeter and an DC voltmeter.

Note 2) A logic analyzer (200MHz or more) is required for complicated troubleshooting.

(2) Tools

Screwdriver (large, medium, small)
Radio pliers

4. DAILY MAINTENANCE AND PERIODIC INSPECTION AND MAINTENANCE
4.2 Maintenance Items

4.2 Maintenance Items

Maintenance is categorized into daily maintenance items (items to be carried at set intervals) and periodic maintenance (replacement of parts when life is reached). Some parts (HD, FDD, etc.) will not function in a hardware manner when the life is reached, so these should be replaced before the life is reached.

Table 4.2 List of maintenance items

Class	Name	Life	Inspection/replacement	Remarks
Daily maintenance	Escutcheon		Once/two months (Accordingly when dirty)	Refer to section 4.4.1.
	Cleaning of floppy disk unit (type built in operation box)		Once/two months	Refer to section 4.4.2.
Periodic maintenance	Replacement of floppy disk (type built in operation box)	3×10^6 passes/track		Refer to section 4.4.2.
	Replacement of floppy disk drive (type built in operation box)	12,000 access hours or 5 years of FDD motor rotation, whichever is sooner	Refer to left.	Refer to section 4.3.2 (5).
	Replacement of hard disk drive	5 years or 20,000 power ON hours, whichever is sooner	Refer to left.	Refer to section 4.3.2 (4).
	LCD display unit (backlight)	10,000 hr (specified with power ON time where brightness drops to less than 50%)	Replace when display dims	Refer to section 4.3.2 (2).
	Battery (lithium battery)	Cumulative data hold time 45,000 hr	When battery drop caution alarm occurs (Guideline: approx. 5 years)	Refer to section 4.3.2 (1).
	Cooling fan (control section)	30,000 hr	Refer to left.	Refer to section 4.3.2 (3).
Other consumable parts	Keyboard	10^6 punches	Refer to left.	Refer to section 4.3.2 (7).

4.3 Replacement Methods

4.3.1 Cable

If the cable is replaced without turning the power OFF, the normal unit or peripheral devices could be damaged, and risks could be imposed.

Disconnect each cable with the following procedures.

- a) For the following type of connector, press the tabs with a thumb and forefinger in the direction of the arrow, and pull the connector off.

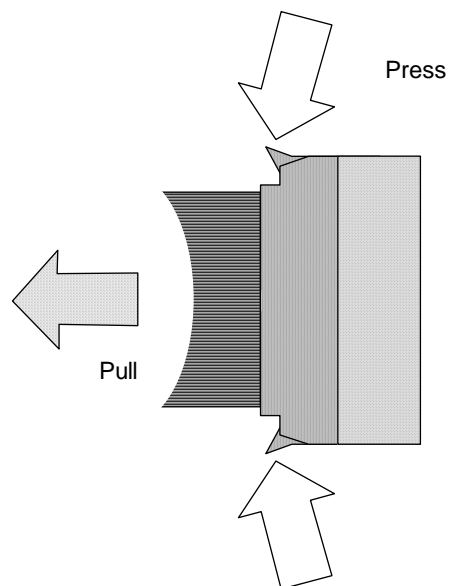
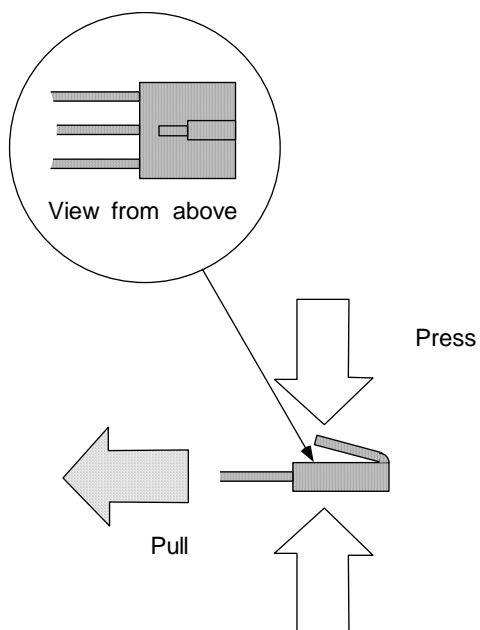
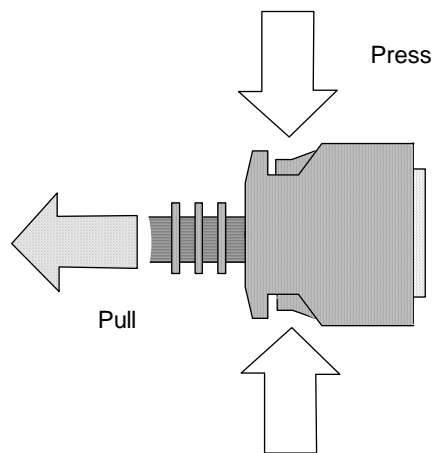
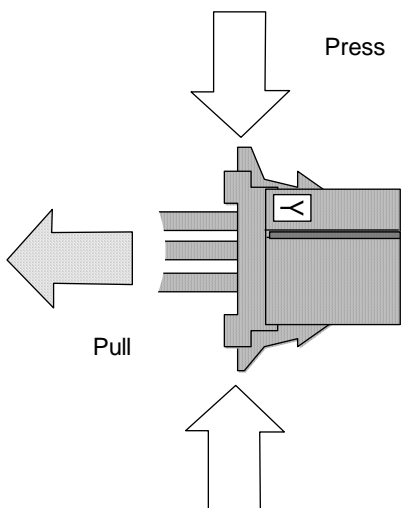

- ⊘ Do not connect or disconnect the connection cables between each unit while the power is ON.
- ⊘ Do not connect the cable by pulling on the cable wire.

4. DAILY MAINTENANCE AND PERIODIC INSPECTION AND MAINTENANCE

4.3 Replacement Methods

- b) For a flat cable type connector with claws, open the claws in the directions of the arrows, and pull the connector off.

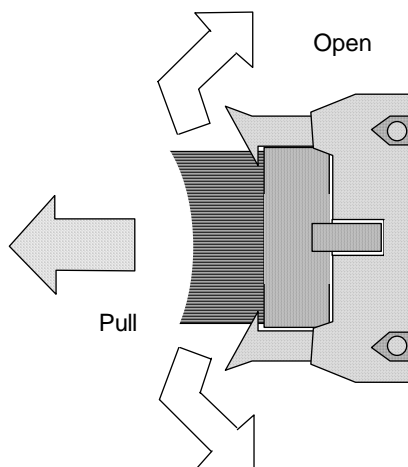

- c) For a flat cable type connector without claws, hold the connector with a thumb and forefinger, and pull the connector off.

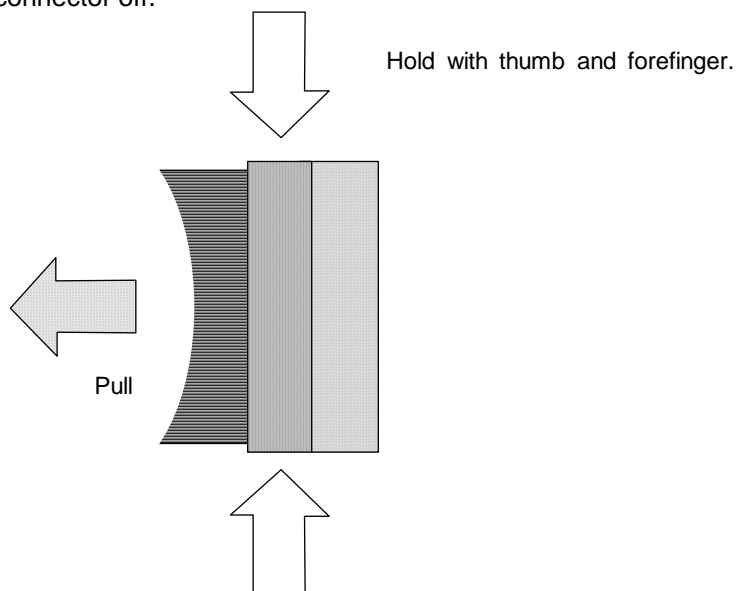

- d) For the screw fixed type connector, loosen the two fixing screws, and pull the connector off.

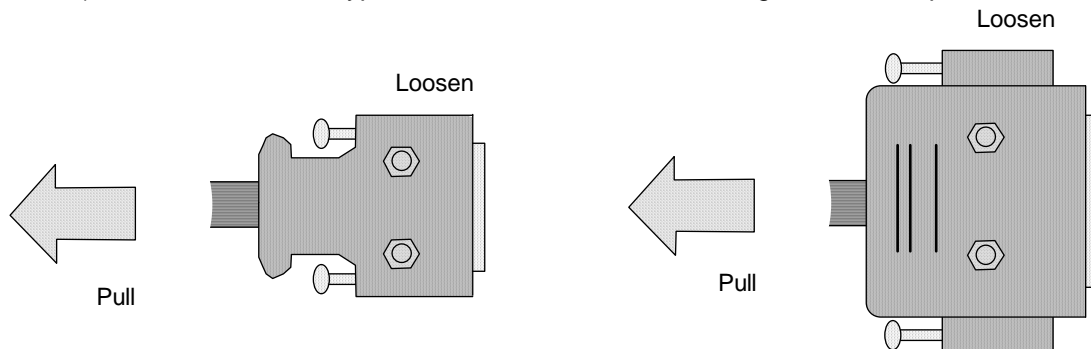

CAUTION

- ⊘ Do not connect or disconnect the connection cables between each unit while the power is ON.
- ⊘ Do not connect the cable by pulling on the cable wire.

4. DAILY MAINTENANCE AND PERIODIC INSPECTION AND MAINTENANCE

4.3 Replacement Methods

4.3.2 Durable parts

(1) Battery

All data, such as the parameters and machining programs that need to be backed up when the power is turned OFF, are saved by a lithium battery installed in the control unit's battery holder.

Battery	With ER6 connector (Toshiba with Mitsubishi specifications)
Initial battery voltage	3.6V
Voltage at which voltage drop is detected	2.8V (Battery voltage drop caution alarm) 2.6V (Battery voltage drop warning alarm)
Battery back up time	45,000 hours (At room temperature. The life will be shorter if the temperature is high.)
Battery life	Approx. 5 years (from date of battery manufacture)
Discharge current	40 μ A or less

(Replace the battery when the battery voltage drop caution alarm appears. The internal data could be damaged if the battery voltage drop warning alarm appears.)

a) Replacement procedures

Always replace the battery with the control section power turned OFF.

Complete the replacement within 30 minutes after turning the power OFF. (If the battery is not connected within 30 minutes, the data being backed up will be destroyed.)

Check that the control section power is turned OFF. (If the power is not OFF, turn it OFF.)

Open the operation box door, and then open the front cover of the control section.

Remove the battery from the battery holder.

Pull the connector connected to the battery out from the BAT connector on the control section PCB HR081.

Insert the connector connected to the new battery into the BAT connector on the control section PCB HR081.

Fit the battery into the battery holder.

Close the front cover of the control section, and then close the operation box door.

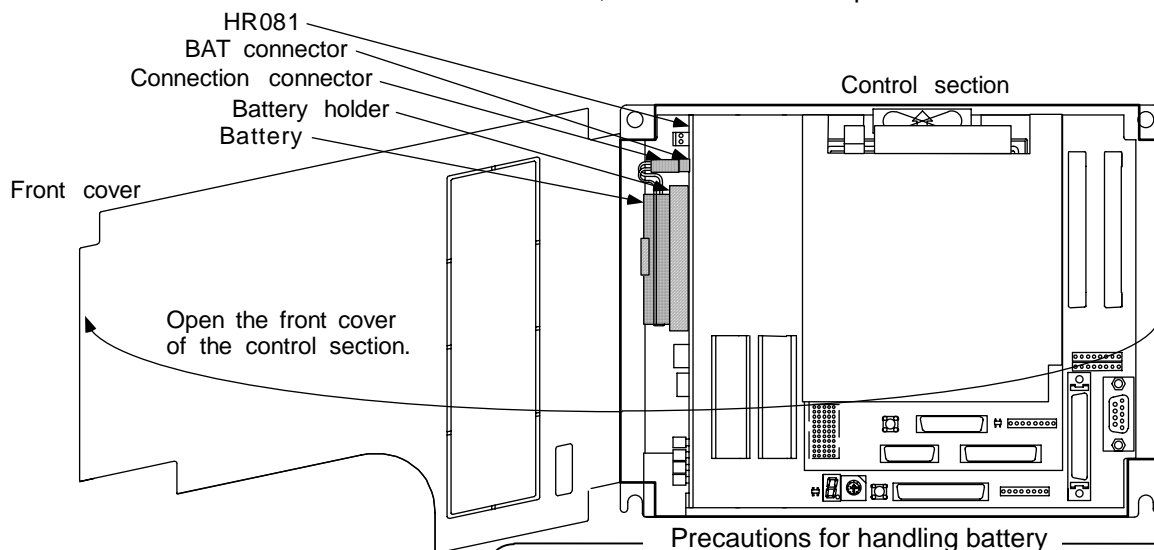

Precautions for handling battery

- Always replace the battery with the same type.
- Do not disassemble the battery.
- Do not place the battery in flames or water.
- Do not pressurize and deform the battery.
- This is a primary battery so do not charge it.
- Dispose of the spent battery as industrial waste.



❗ If the battery voltage drop warning alarm occurs, the programs, tool data and parameters could be damaged. Thus, reload each data with the input/output device after replacing the battery.

⚠ Do not replace the battery while the power is ON.

⚠ Do not short circuit, charge, overheat, incinerate or disassemble the battery.

⚠ Dispose the spent battery according to local laws.

4. DAILY MAINTENANCE AND PERIODIC INSPECTION AND MAINTENANCE

4.3 Replacement Methods

(2) Backlight

A cold cathode tube is used for the light source (backlight) of the LCD panel.

The life of the backlight is 10,000 hours/25°C. (Time for the brightness to drop to 50% of the initial value.)

The life depends on the temperature, and when used continuously at low temperatures, the life will be shorter.

LCD panel KCS6448HSTT-X3 (Kyocera)

Backlight KCI-04 (Kyocera)

Backlight life 10,000 hours/25°C (Time for the brightness to drop to 50% of the initial value.)

a) Replacement procedures

Always replace the LCD panel backlight with the control section power turned OFF.

Check that the control section power is turned OFF. (If the power is not OFF, turn it OFF.)

Open the operation box door.

Disconnect the backlight connection connector from the backlight power supply PCB. (two connections on top and bottom)

Remove the fixing screws (two screws on left top and bottom) for the control section installation fitting, and open the control section installation fitting.

Pull out the backlight built into the left top and bottom of the LCD panel. (Lock claws are provided on the front of the backlight, so press these while pulling out the backlight.)

Insert two new backlights into the left top and bottom of the LCD panel. (Insert until the lock claws click.)

Close the control section installation fitting, and fix the with the fixing screws (two screws on left top and bottom).

Connect the backlight connection connector to the backlight power supply PCB.

Close the operation box door.

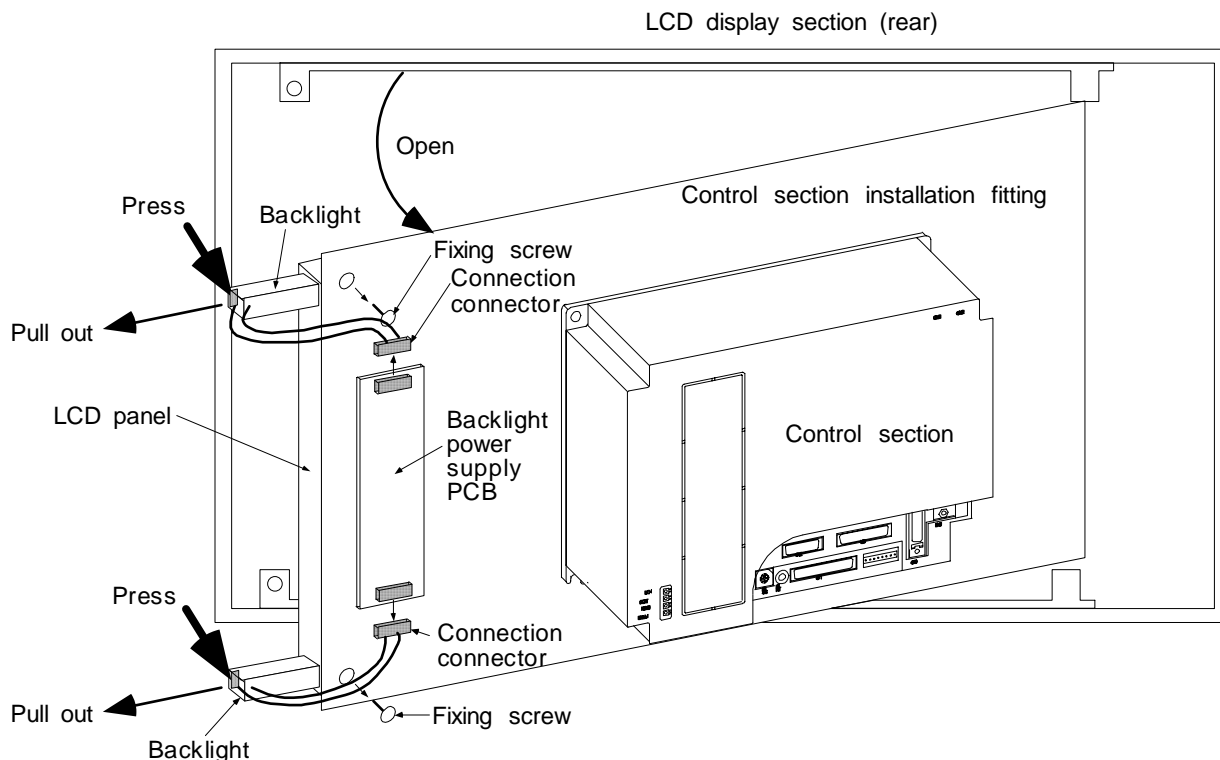

⚠ Do not replace the backlight while the power is ON.

⚠ Dispose the spent backlight according to local laws.

4. DAILY MAINTENANCE AND PERIODIC INSPECTION AND MAINTENANCE

4.3 Replacement Methods

(3) Cooling fan

In the system mounted with the card PC, a fan is mounted on the top of the control section to cool the card PC.

The system specifications are structured so that the temperature is detected, and when below the set temperature, the cooling fan does not function.

Cooling fan MMF-04B05DM-R (DDK with Mitsubishi specifications)

Cooling fan life ... 30,000 hours

a) Replacement procedures

Always replace the cooling fan with the control section power turned OFF.

Check that the control section power is turned OFF. (If the power is not OFF, turn it OFF.)

Open the operation box door.

Remove the fan cover at the upper center of the control section. (Insert a small flat-tip screwdriver into the groove of the control section's cooling fan section, and remove the fan cover.)

Pull out the cooling fan from the control section's cooling fan storage section.

Disconnect the cooling fan connection connector from the control section PCB.

Replace with a new cooling fan, and connect the cooling fan connection connector to the control section PCB.

Fit the cooling fan into the control section's cooling fan storage section. (Store so that the arrow on the side of the cooling fan faces upward.)

Arrange the cooling fan wiring, and fit into the control section's cooling fan storage section.

Install the fan cover. (Install the protruding side of the fan cover onto the control section, and then install the grooved side onto the control section.)

Close the operation box door.

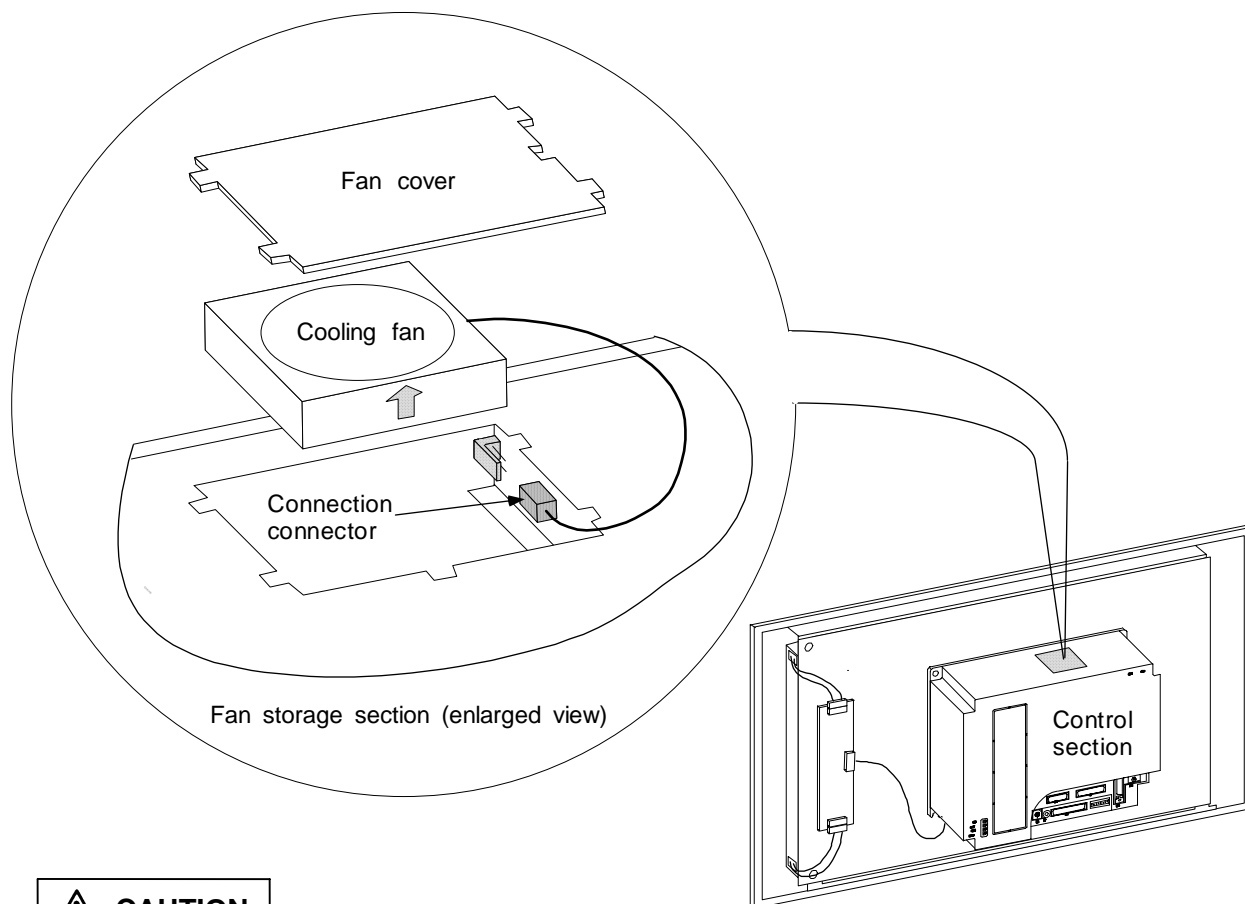

CAUTION

 Do not replace the cooling fan while the power is ON.

 Dispose the spent cooling fan according to local laws.

4. DAILY MAINTENANCE AND PERIODIC INSPECTION AND MAINTENANCE

4.3 Replacement Methods

(4) Hard disk (HDD)

Depending on the hardware specifications, the HDD may be built into the control section or may be installed externally. In either case, the HDD is connected to the control section PCB HR121 with an F140 cable.

HDD.....	MK1924FCV (Toshiba)
HDD life	5 years or 20,000 power ON hours, whichever is sooner
HDD unit.....	FCU6-HD101-1 (Mitsubishi Electric)

a) Replacement procedures

<When built into control section>

Always replace the HDD with the control section power turned OFF.

Check that the control section power is turned OFF. (If the power is not OFF, turn it OFF.)

Open the operation box door, and then open the front cover of the control section.

If the PCMCIA interface PCB HR841 is built into the control section, remove it.

(Refer to section *.* for the removal methods.)

Disconnect the F140 cable connected to the control section PCB HR121.

Remove the HDD fixing fitting screws, and remove the HDD fixing fitting.

While holding the area near the right center of the HDD installation fitting, remove the HDD with the installation fitting intact.

Remove the HDD from the HDD installation fitting. (Pull toward the top of the installation fitting.

Remove with the damping rubber intact.)

Disconnect the F140 cable from the HDD, and connect the F140 cable to the new HDD. (Take care to the connection direction when installing.)

With the HDD PCB section facing upward, install the HDD onto the HDD installation fitting.

(Install the HDD onto the groove of the damping rubber installed on the HDD installation fitting.)

Install the damping rubber between the tops of the HDD and HDD installation fitting. (Install the damping rubber so that it fits securely into the positioning holes on the side of the HDD installation fitting.)

Install the HDD installation fitting onto the control section.

Install the HDD fixing fitting, and fix with the fixing screws. (Insert the HDD fixing fitting between the HDD installation fitting and the claws on the left side of the control section case.

Connect the F140 cable from the HDD to the control section PCB HR121.

If the PCMCIA interface PCB HR841 is built into the control section, install it. (Refer to section *.* for the installation methods.)

Close the front cover of the control section, and then close the operation box door.

Refer to the replacement procedure diagram on page *.

<When installed outside the control section: HDD unit>

Always replace the HDD unit with the control section power turned OFF.

Check that the control section power is turned OFF. (If the power is not OFF, turn it OFF.)

Open the operation box door.

Disconnect the heater power cable connected from the HDD unit to the operation section PCB.

Disconnect the F140 cable connected to the HDD in the HDD unit. (Disconnect the F140 cable while supporting the front and rear of the HDD with fingers.)

Remove the HDD unit installation screws, and remove the HDD unit from the operation box.

Replace with the new HDD unit, and fix the HDD unit onto the operation box with the installation screws.

Connect the F140 cable to the HDD in the HDD unit.

(Fix the F140 cable while supporting the front and rear of the HDD with fingers. Take care to the direction.)

Connect the HDD unit heater power cable to the operation section PCB.

Close the operation box door.

Refer to the replacement procedure diagram on page *.



4. DAILY MAINTENANCE AND PERIODIC INSPECTION AND MAINTENANCE

4.3 Replacement Methods

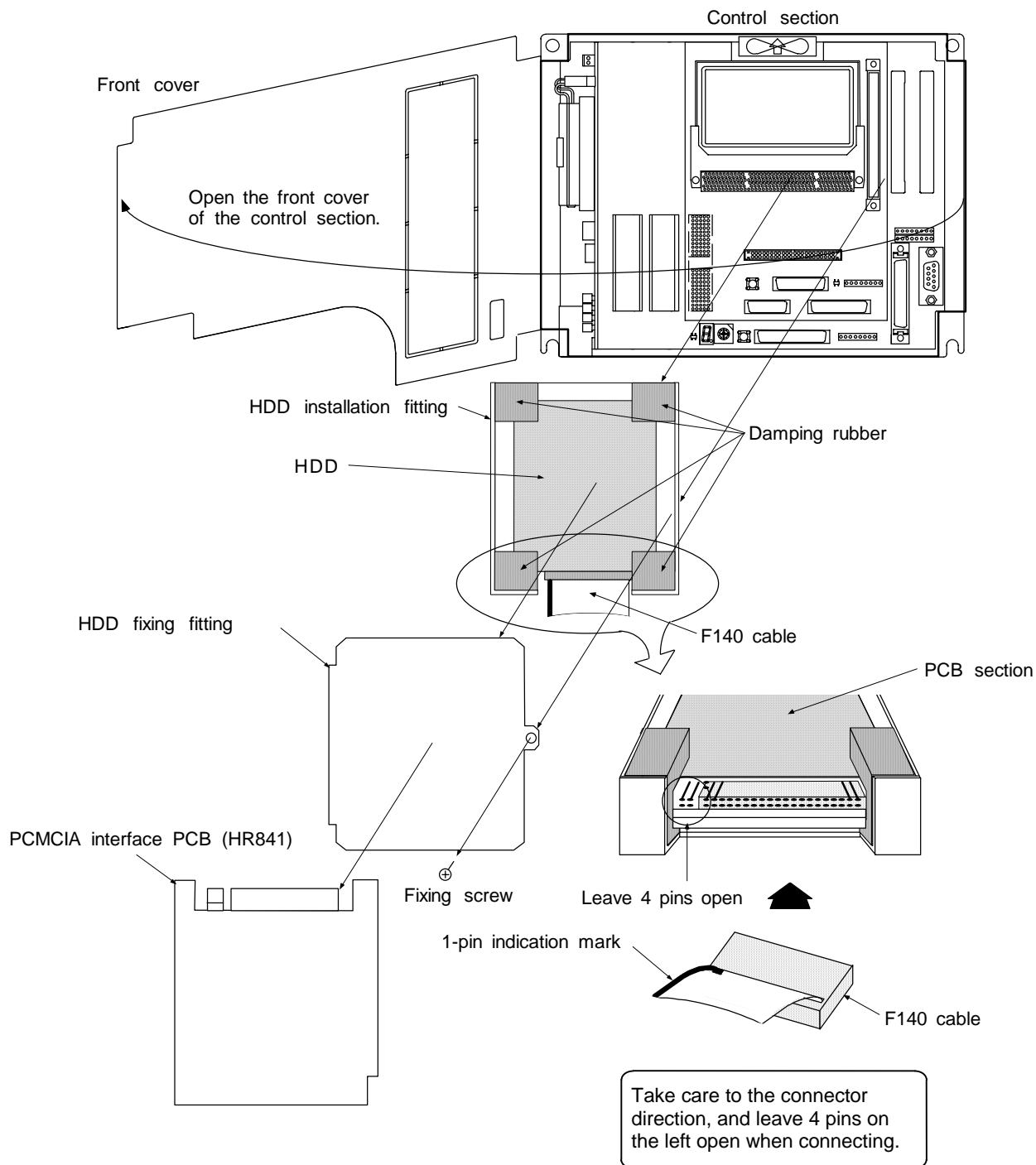
<When built into control section>



CAUTION

-  Incorrect connections may damage the devices, so connect the cables to the specified connectors.
-  Do not replace the HDD while the power is ON.
-  Dispose the spent HDD according to local laws.

4. DAILY MAINTENANCE AND PERIODIC INSPECTION AND MAINTENANCE

4.3 Replacement Methods

<When installed outside the control section: HDD unit>

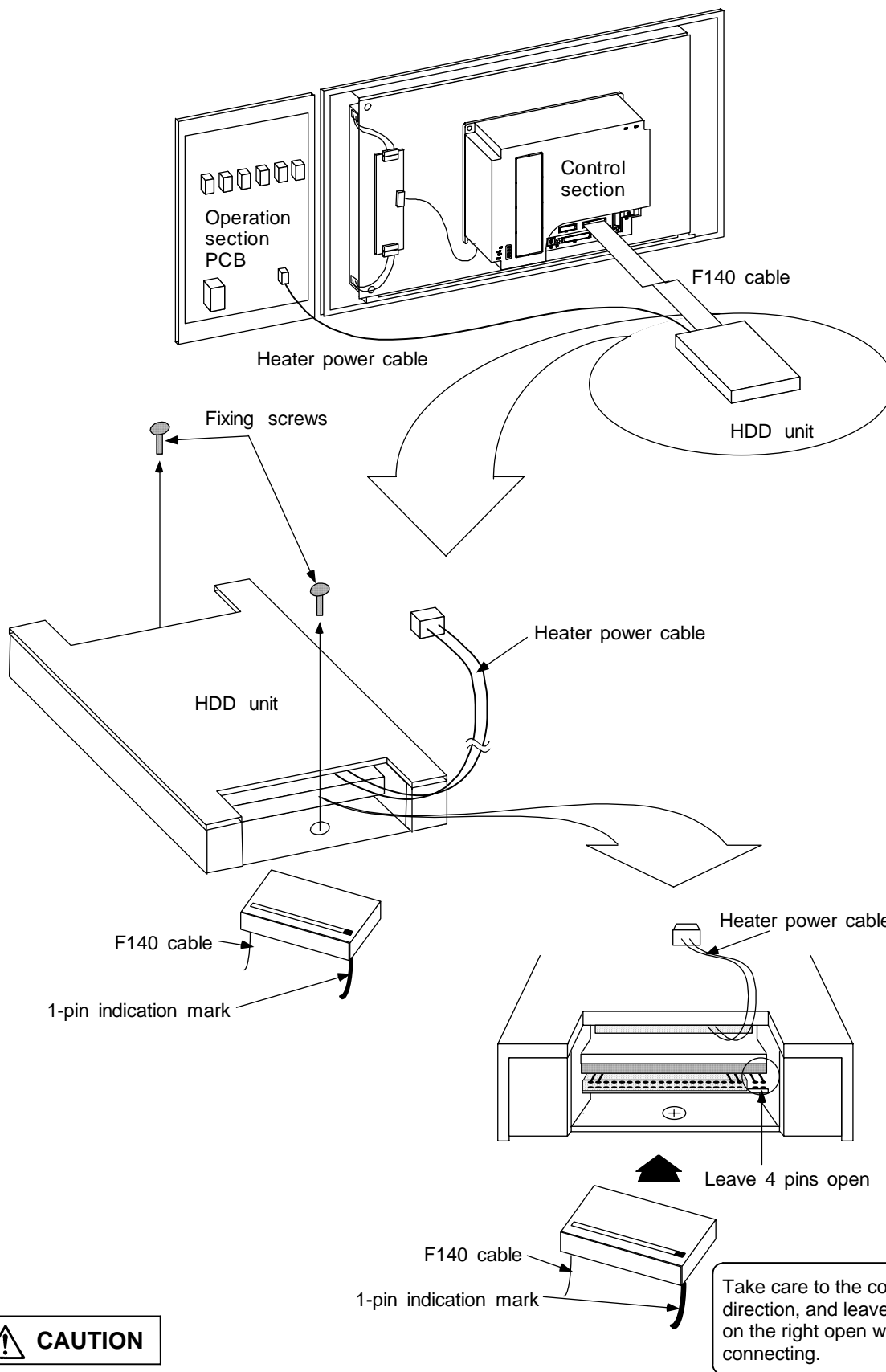

CAUTION

- ⚠ Incorrect connections may damage the devices, so connect the cables to the specified connectors.
- ⚠ Do not replace the HDD while the power is ON.
- ⚠ Dispose the spent HDD according to local laws.

4. DAILY MAINTENANCE AND PERIODIC INSPECTION AND MAINTENANCE

4.3 Replacement Methods

(5) Floppy disk (FDD)

Due to the hardware specifications, the FDD is installed outside of the control section.

The FDD is used as a set with the man-machine interface PCB HR121, and is connected with an F130 cable.

FDD FD-235HG-7332 (TEAC)

FDD life 12,000 access hours or 5 years of FDD motor rotation, whichever is sooner

a) Replacement procedures

Always replace the FDD unit with the control section power turned OFF.

Check that the control section power is turned OFF. (If the power is not OFF, turn it OFF.)

Open the operation box door.

Disconnect the F130 cable connected to the FDD.

Remove the FDD fixing screws, and remove the FDD unit from the FDD installation fitting.

Replace with the new FDD, and fix the FDD onto the FDD installation fitting with the fixing screws.

Connect the F130 cable to the FDD.

Close the operation box door.

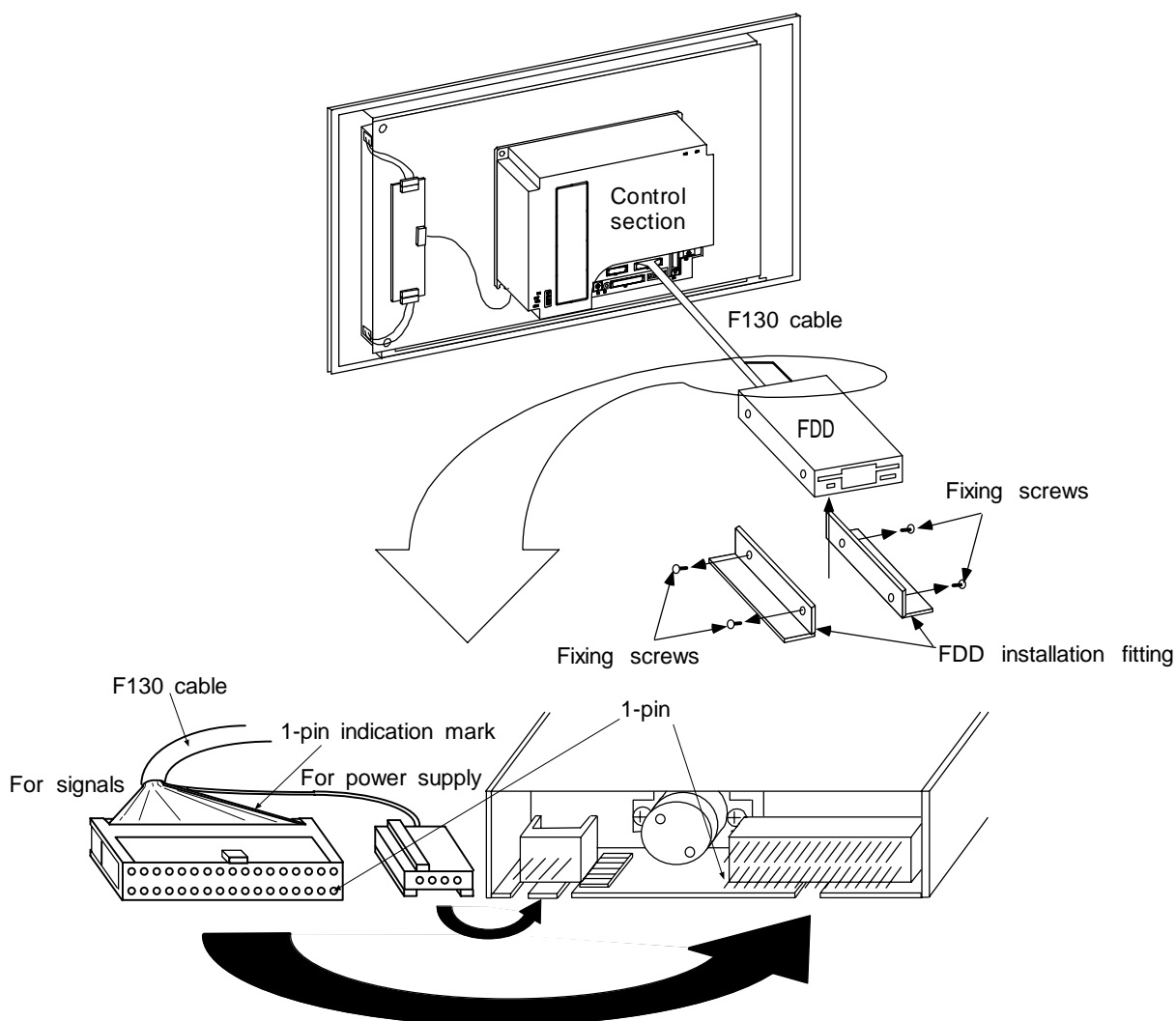

⚠ CAUTION

⚠ Do not replace the FDD while the power is ON.

⚠ Dispose the spent FDD according to local laws.

4. DAILY MAINTENANCE AND PERIODIC INSPECTION AND MAINTENANCE

4.3 Replacement Methods

4.3.3 Unit

(1) Control unit

The basic configuration of the control unit is the type with the control section installed on the display section.

a) Replacement procedures

Always replace the control unit with the control section power turned OFF.

Check that the control section power is turned OFF. (If the power is not OFF, turn it OFF.)

Open the operation box door.

Disconnect all cables connected to the display section and control section.

Remove the fixing screws fixing the control unit onto the operation box, and remove the control unit from the operation box.



Replace with a new control unit, and fix the control unit onto the operation box with the fixing screws.

Connect all cables connected to the display unit and control section. (Connect the cables to the designated connectors.)

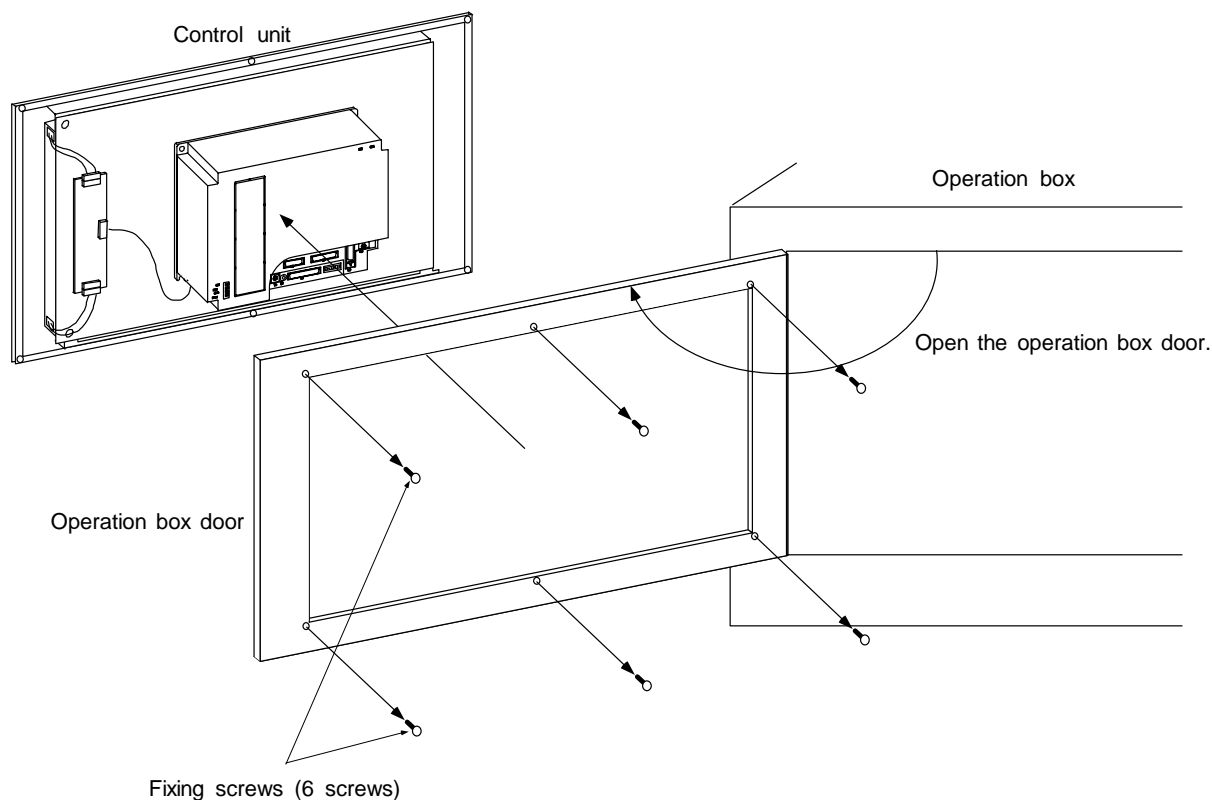
Close the operation box door.



CAUTION

-  Incorrect connections may damage the devices, so connect the cables to the specified connectors.
-  Do not replace the control unit while the power is ON.
-  Do not connect or disconnect the connection cables between each unit while the power is ON.

4. DAILY MAINTENANCE AND PERIODIC INSPECTION AND MAINTENANCE

4.3 Replacement Methods

(2) Control section

As the basic configuration, the control section is installed on the rear side of the display section.

a) Replacement procedures

Always replace the control section with the control section power turned OFF.

Check that the control section power is turned OFF. (If the power is not OFF, turn it OFF.)

Open the operation box door.

Disconnect all cables connected to the control section.

Remove the fixing screws fixing the control section onto the control section installation fitting, and remove the control section from the fitting. (Loosen the two lower fixing screws first, and then remove the two upper fixing screws while supporting the control section with a hand. Lift the control section upward and off. The two lower fixing screws do not need to be removed.)



Replace with a new control section, and fix the control section onto the control section installation fitting.

Connect all cables connected to the control section. (Connect the cables to the designated connectors.)

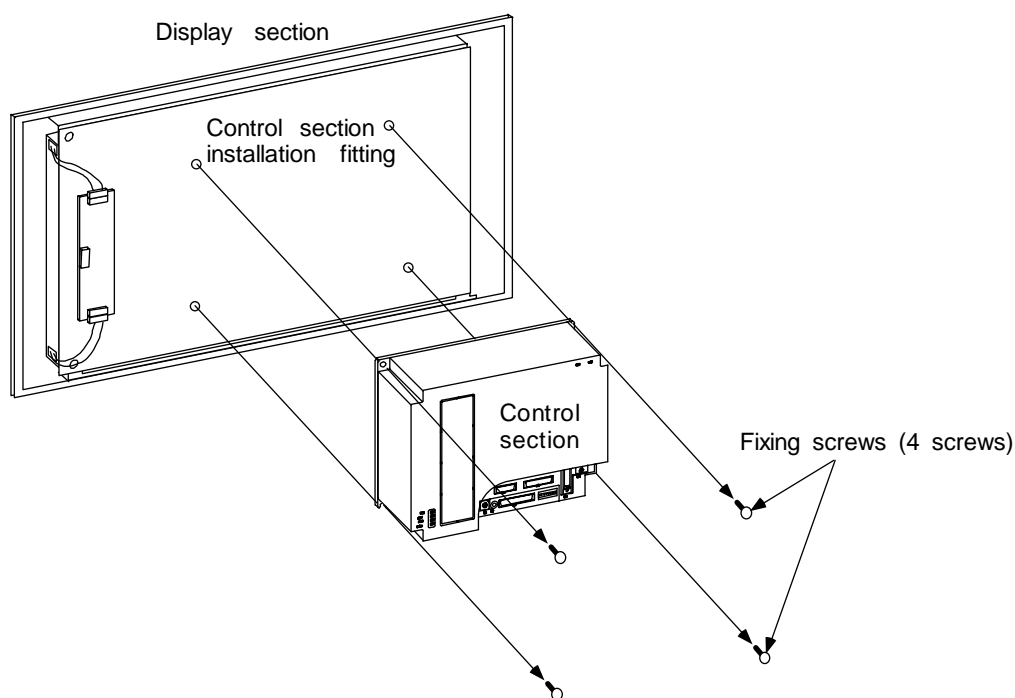
Close the operation box door.



CAUTION

-  Incorrect connections may damage the devices, so connect the cables to the specified connectors.
-  Do not replace the control section while the power is ON.
-  Do not connect or disconnect the connection cables between each unit while the power is ON.

4. DAILY MAINTENANCE AND PERIODIC INSPECTION AND MAINTENANCE

4.3 Replacement Methods

(3) Display section (LCD panel)

The display section's LCD panel is installed on the escutcheon side of the control section's installation fitting.

a) Replacement procedures

Always replace the display section's LCD panel with the control section power turned OFF.

Check that the control section power is turned OFF. (If the power is not OFF, turn it OFF.)

Open the operation box door.

Disconnect the backlight connection connector from the backlight power supply PCB. (Two connectors on top and bottom)

Remove the control section installation fitting fixing screws (two screws on left top and bottom), and open the control section installation fitting.

Disconnect the F091/092 cable from the CON1/2 connector at the left center of the LCD panel.

Remove the four fixing screws fixing the LCD panel to the control section installation fitting, and remove the LCD panel from the control section installation fitting. (Remove the two lower fixing screws first, and then remove the two upper fixing screws while supporting the LCD panel with a hand. Then remove the LCD panel.)

Replace with a new LCD panel, and fix the LCD panel to the control section installation fitting with the installation screws.

Connect the F091/092 cable to the CON1/2 connector at the left center of the LCD panel.

(Connect the cables to the designated connectors.)



Close the control section installation fitting, and fix with the fixing screws (two screws on left top and bottom).

Connect the backlight connection connector to the backlight power supply PCB.

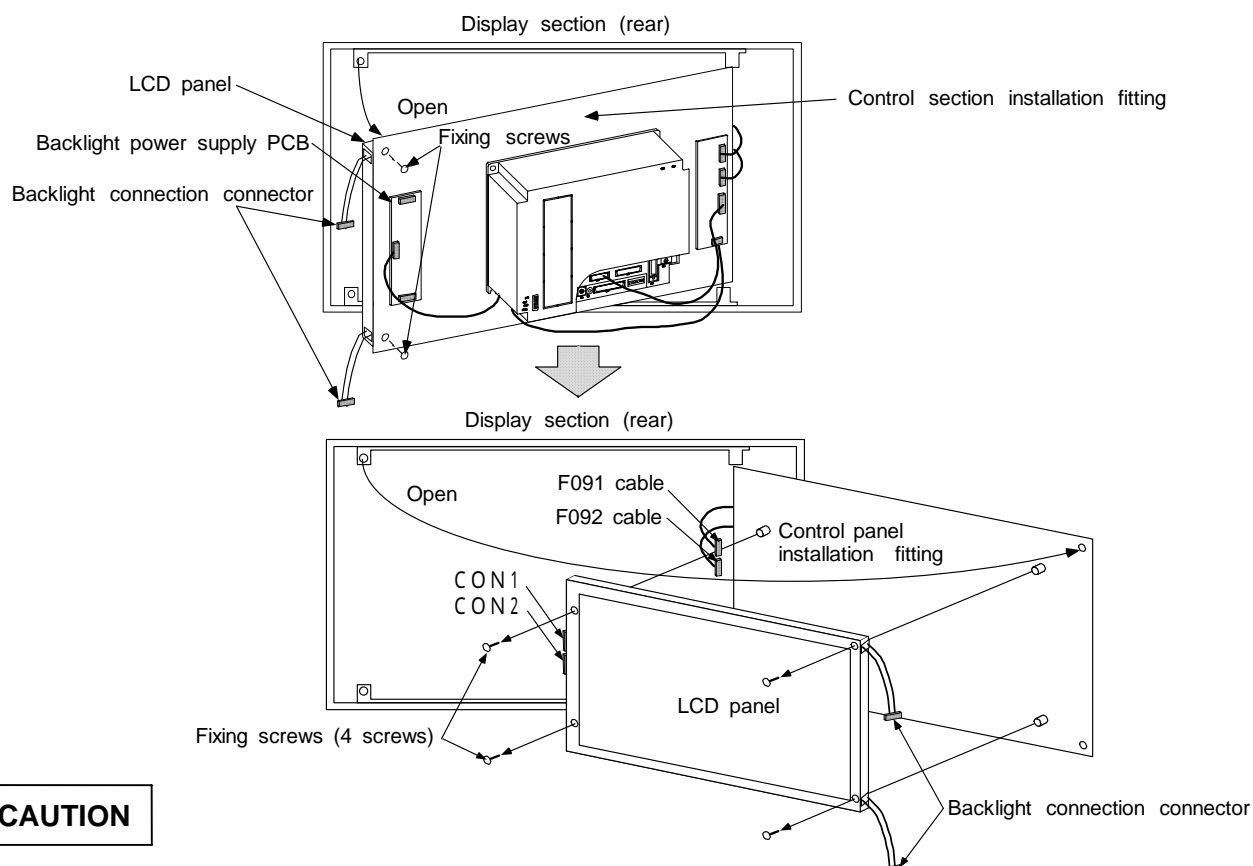
Close the operation box door.



CAUTION

-  Incorrect connections may damage the devices, so connect the cables to the specified connectors.
-  Do not replace the display section (LCD panel) while the power is ON.
-  Do not connect or disconnect the connection cables between each unit while the power is ON.

4. DAILY MAINTENANCE AND PERIODIC INSPECTION AND MAINTENANCE

4.3 Replacement Methods

(4) Base I/O unit

The base I/O unit is generally installed on the electric cabinet side.

a) Replacement procedures

Always replace the base I/O unit with the control section power turned OFF.

Check that the control section power is turned OFF. (If the power is not OFF, turn it OFF.)

Open the electric cabinet door.

Disconnect all cables connected to the base I/O unit.

Remove the fixing screws fixing the base I/O unit to the electric cabinet, and remove the base I/O unit from the electric cabinet.

(Loosen the two lower fixing screws first, and then remove the two upper fixing screws while supporting the unit with a hand. Then lift the unit upward and off. The two lower fixing screws do not need to be removed.)



Replace with a new base I/O unit, and fix the unit onto the electric cabinet with the fixing screws.

Connect all cables connected to the base I/O unit. (Connect the cables to the designated connectors.)

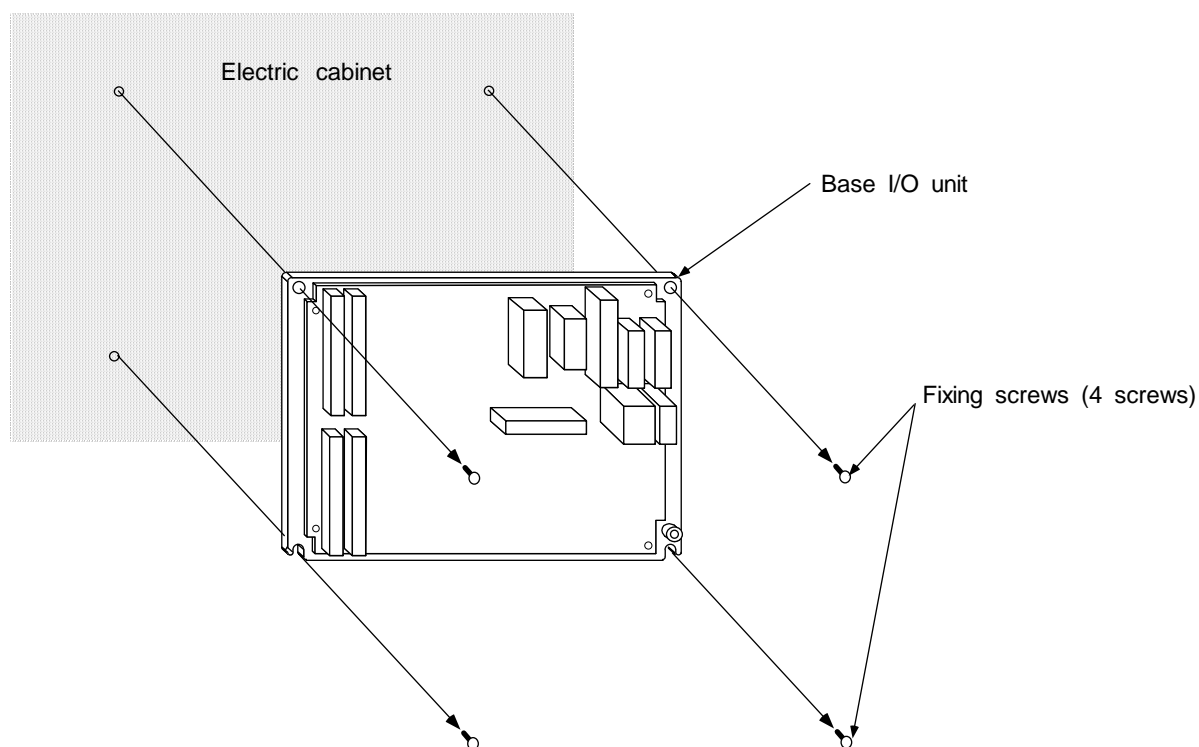
Close the electric cabinet door.



CAUTION

-  Incorrect connections may damage the devices, so connect the cables to the specified connectors.
-  Do not replace the base I/O unit while the power is ON.
-  Do not connect or disconnect the connection cables between each unit while the power is ON.

4. DAILY MAINTENANCE AND PERIODIC INSPECTION AND MAINTENANCE

4.3 Replacement Methods

(5) External power supply unit (PD25)

The external power supply unit is the 24VDC power supply for the control section used for the system mounted with an HDD.

This unit is generally installed in the electric cabinet.

a) Replacement procedures

Always replace the external power supply unit with the control section power turned OFF.

Check that the control section power is turned OFF. (If the power is not OFF, turn it OFF.)

Open the electric cabinet door.

Disconnect all cables connected to the external power supply unit.

Remove the fixing screws fixing the external power supply unit to the electric cabinet, and remove the external power supply unit from the electric cabinet.

(Loosen the two lower fixing screws first, and then remove the upper fixing screw while supporting the unit with a hand. Then lift the unit upward and off. The two lower fixing screws do not need to be removed.)



Replace with a new external power supply unit, and fix the unit onto the electric cabinet with the fixing screws.

Connect all cables connected to the external power supply unit. (Connect the cables to the designated connectors.)

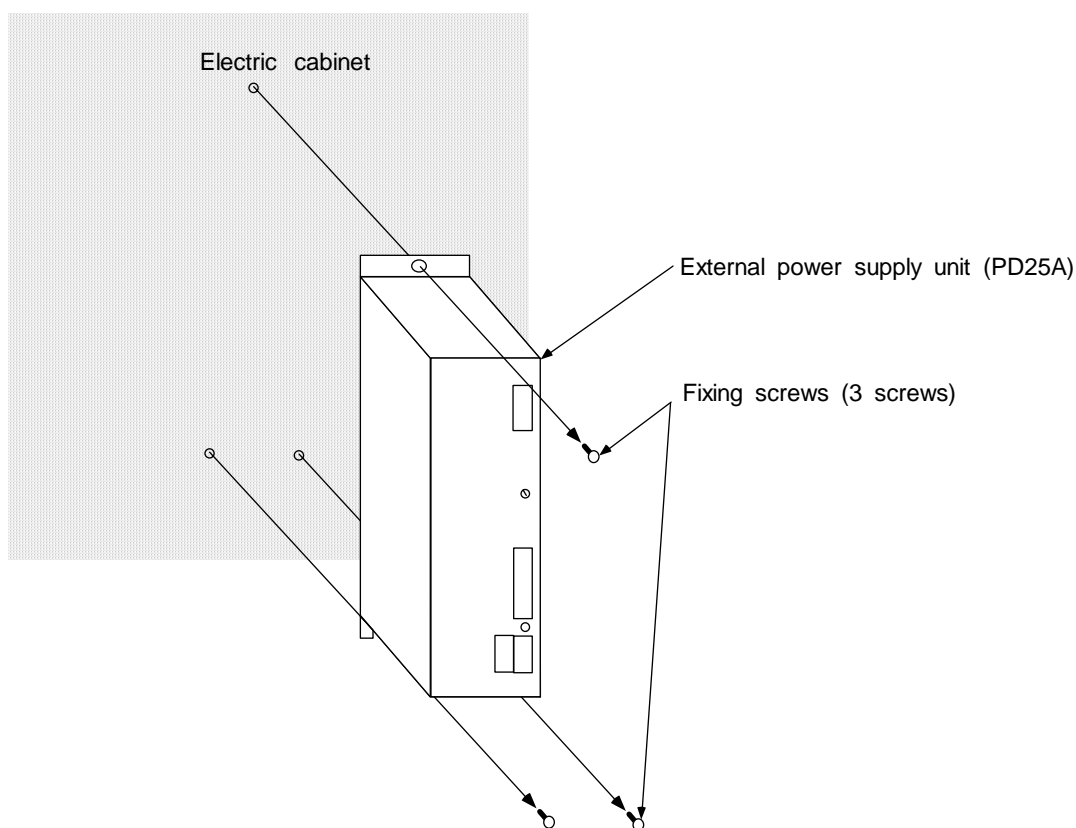
Close the electric cabinet door.



CAUTION

-  Incorrect connections may damage the devices, so connect the cables to the specified connectors.
-  Do not replace the external power supply unit while the power is ON.
-  Do not connect or disconnect the connection cables between each unit while the power is ON.

4. DAILY MAINTENANCE AND PERIODIC INSPECTION AND MAINTENANCE

4.3 Replacement Methods

(6) PCMCIA card

In the system mounted with the PCMCIA interface PCB HR841, up to two commercial PCMCIA cards can be connected.

Install the driver for the PCMCIA card to be used before starting the system. (Refer to the software operation manual and the instruction manual of the PCMCIA card being used on how to install the software.)

a) Replacement procedures

Always replace the PCMCIA card with the control section power turned OFF.

Check that the control section power is turned OFF. (If the power is not OFF, turn it OFF.)

Open the operation box door, and then open the front cover of the control section.



Press the eject button at the left side of the PCMCIA card to be replaced, and remove the PCMCIA card from the PCMCIA interface PCB HR841.

Insert the new PCMCIA card into the open slot of the PCMCIA interface PCB HR841. (Insert the PCMCIA card with the side having the product name printed toward the back and the connection connector side facing down. Insert until the eject button clicks.)

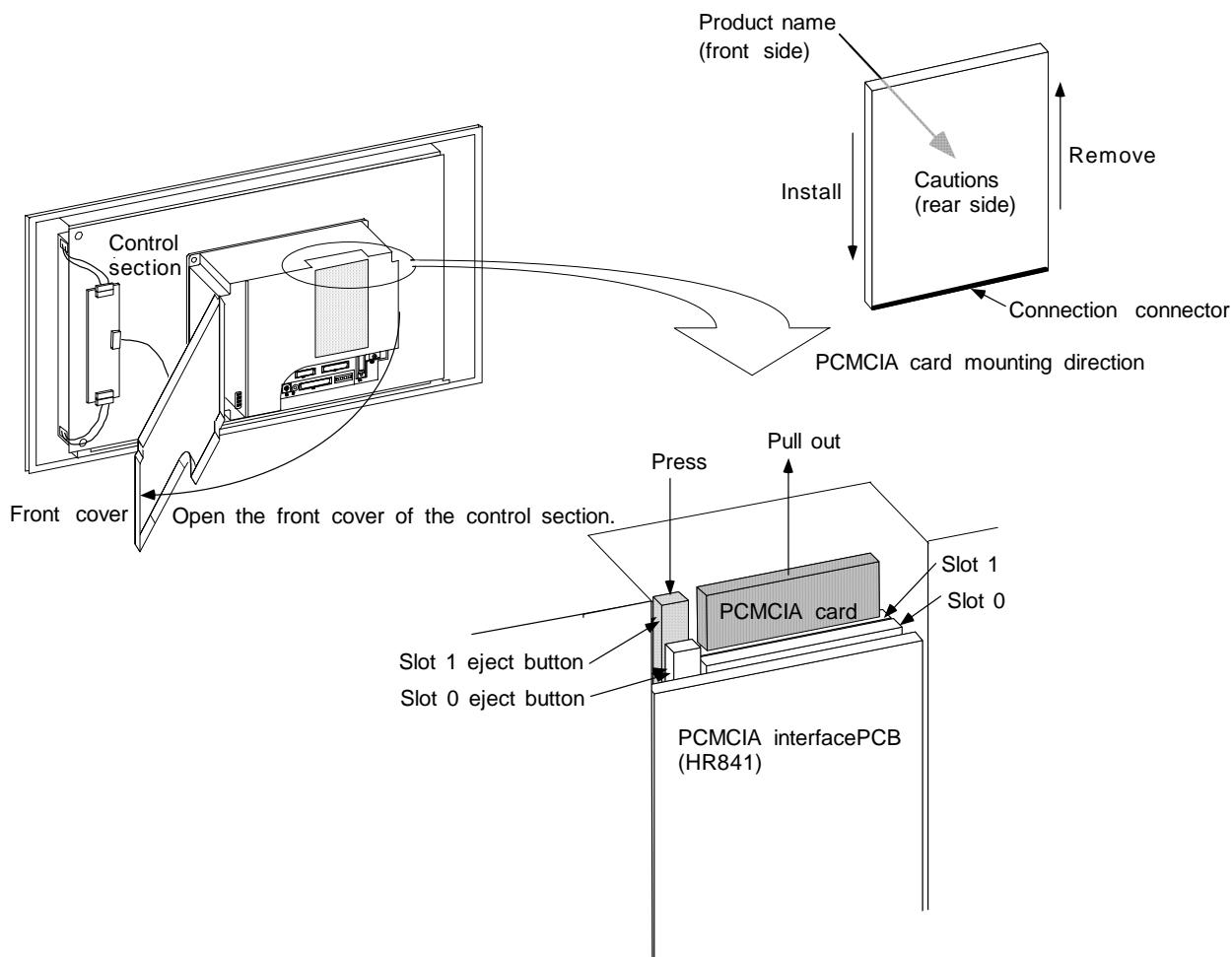
Close the front cover of the control section, and then close the operation box door.



CAUTION

-  Incorrect connections may damage the devices, so connect the PCMCIA card to the specified connector.
-  Do not replace the PCMCIA card while the power is ON.

4. DAILY MAINTENANCE AND PERIODIC INSPECTION AND MAINTENANCE

4.3 Replacement Methods

(7) Keyboard

The keyboard is installed on the display section periphery.

a) Replacement procedures

Always replace the keyboard with the control section power turned OFF.

Check that the control section power is turned OFF. (If the power is not OFF, turn it OFF.)

Open the operation box door.

Disconnect all cables connected to the keyboard.

Remove the fixing screw fixing the keyboard to the operation box, and remove the keyboard from the operation box.



Replace with a new keyboard, and install the keyboard onto the operation box with the fixing screws.

Connect all cables connected to the keyboard. (Connect the cables to the designated connectors.)

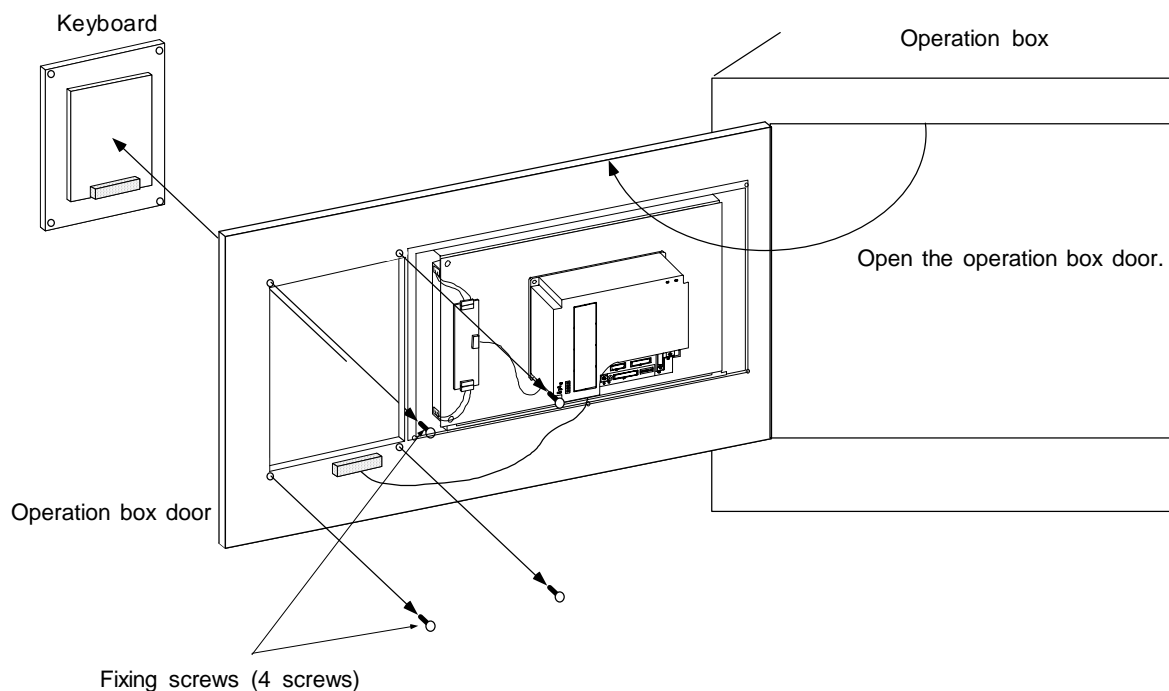
Close the operation box door.



CAUTION

-  Incorrect connections may damage the devices, so connect the cables to the specified connectors.
-  Do not replace the keyboard while the power is ON.
-  Do not connect or disconnect the connection cables between each unit while the power is ON.

4. DAILY MAINTENANCE AND PERIODIC INSPECTION AND MAINTENANCE

4.3 Replacement Methods

4.3.4 Control PCB

(1) Control section power supply PCB (HR081)

The control section power supply PCB is supplied with 24VDC from an external source. This PCB generates the DC voltage required for each control PCB in the control section.

a) Replacement procedures

Always replace the control section power supply PCB with the control section power turned OFF. A battery for backing up the memory is mounted on the control section power supply PCB, so as with the battery, replace the control section power supply PCB within 30 minutes.

Check that the control section power is turned OFF. (If the power is not OFF, turn it OFF.)

Open the operation box door, and then open the front cover of the control section.

Disconnect all cables connected to the control section power supply PCB.

While holding the front upper and lower sections of the control section power supply PCB with both hands, pull out the PCB from the control section.

Remove the battery from the control section power supply PCB that was removed.

Replace with a new control power supply PCB, and install the battery.

Install the control section power supply PCB into the control section. (Align the control section power supply PCB with the PCB fixing guides on the inner side of the control section case, and then install.)

Connect all cables connected to the control section power supply PCB. (Connect the cables to the designated connectors.)

Close the front cover of the control section, and then close the operation box door.

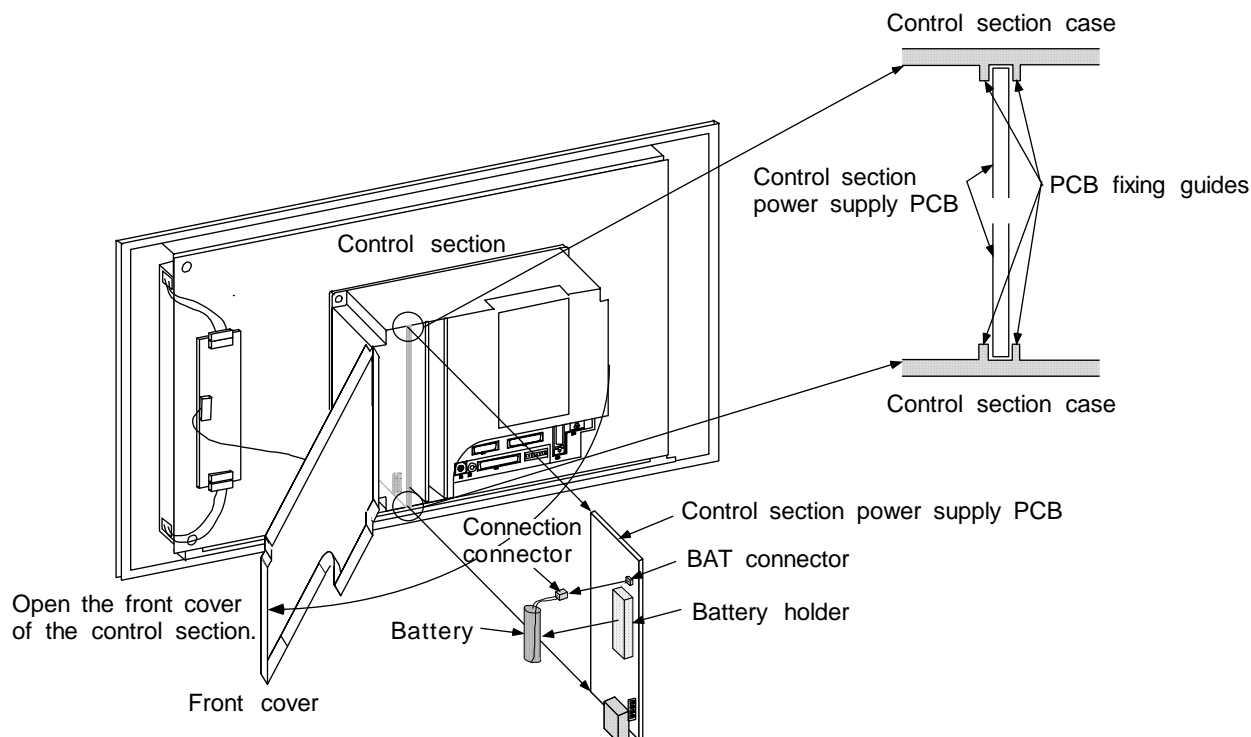

CAUTION

- ⚠ Incorrect connections may damage the devices, so connect the cables to the specified connectors.
- ⚠ Do not replace the control section power supply PCB while the power is ON.
- ⚠ Do not connect or disconnect the connection cables between each unit while the power is ON.

4. DAILY MAINTENANCE AND PERIODIC INSPECTION AND MAINTENANCE

4.3 Replacement Methods

(2) PCMCIA interface PCB (HR841)

The PCMCIA interface PCB is used when connecting commercial PCMCIA cards. Depending on the hardware specifications, the PCB may be built into the control section.

This PCB is used as a set with the man-machine interface PCB HR121, and is connected with the F150 cable.

a) Replacement procedures

Always replace the PCMCIA interface PCB with the control section power turned OFF.

Check that the control section power is turned OFF. (If the power is not OFF, turn it OFF.)

Open the operation box door, and then open the front cover of the control section.

Remove the PCMCIA interface PCB from the control section. (Open the PCB fixing claws on the left and right of the PCMCIA interface PCB storage section, and remove the PCB.)

Disconnect the F150 cable connected to the ISA connector on the PCMCIA interface PCB.



Replace with a new PCMCIA interface PCB, and connect the F150 cable to the ISA connector.

Face the ISA connector section of the PCMCIA interface PCB to the back, and install the PCB in the control section.

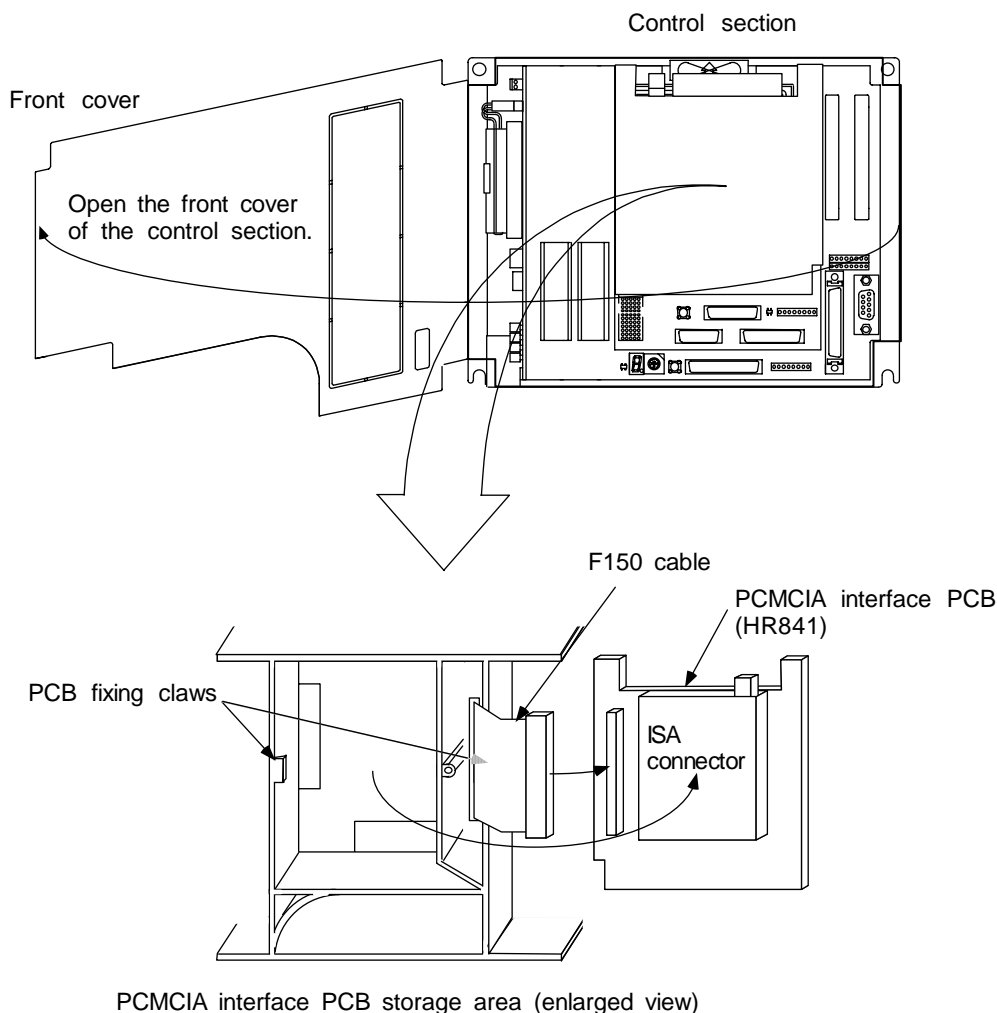
Close the front cover of the control section, and close the operation box door.



CAUTION

-  Incorrect connections may damage the devices, so connect the cables to the specified connectors.
-  Do not replace the PCMCIA interface PCB while the power is ON.

4. DAILY MAINTENANCE AND PERIODIC INSPECTION AND MAINTENANCE

4.3 Replacement Methods

(3) Backlight power supply PCB

The backlight power supply PCB is supplied with 12VDC from the control section power supply. This PCB generates a high voltage AC voltage for lighting the backlight of the LCD panel.

a) Replacement procedures

Always replace the backlight power supply PCB with the control section power turned OFF.

Check that the control section power is turned OFF. (If the power is not OFF, turn it OFF.)

Open the operation box door.

Disconnect all cables connected to the backlight power supply PCB.

Remove the two protective cover fixing screws, and then remove the protective cover.

(Remove a fixing screw on one side, and then while supporting the protective cover with a hand, remove the other fixing screw.)

Remove the two hexagon spacers fixing the backlight power supply PCB, and remove the backlight power supply PCB. (Remove a hexagon spacer on one side, and then while supporting the PCB with a hand, remove the other hexagon spacer.)

Replace with a new backlight power supply PCB, and install the PCB onto the control section installation fitting with the hexagon spacers.



Install the hexagon spacers that fix the protective cover onto the backlight power supply PCB, and fix with the fixing screws.

Connect all cables connected to the backlight power supply PCB. (Connect the cables to the designated connectors.)

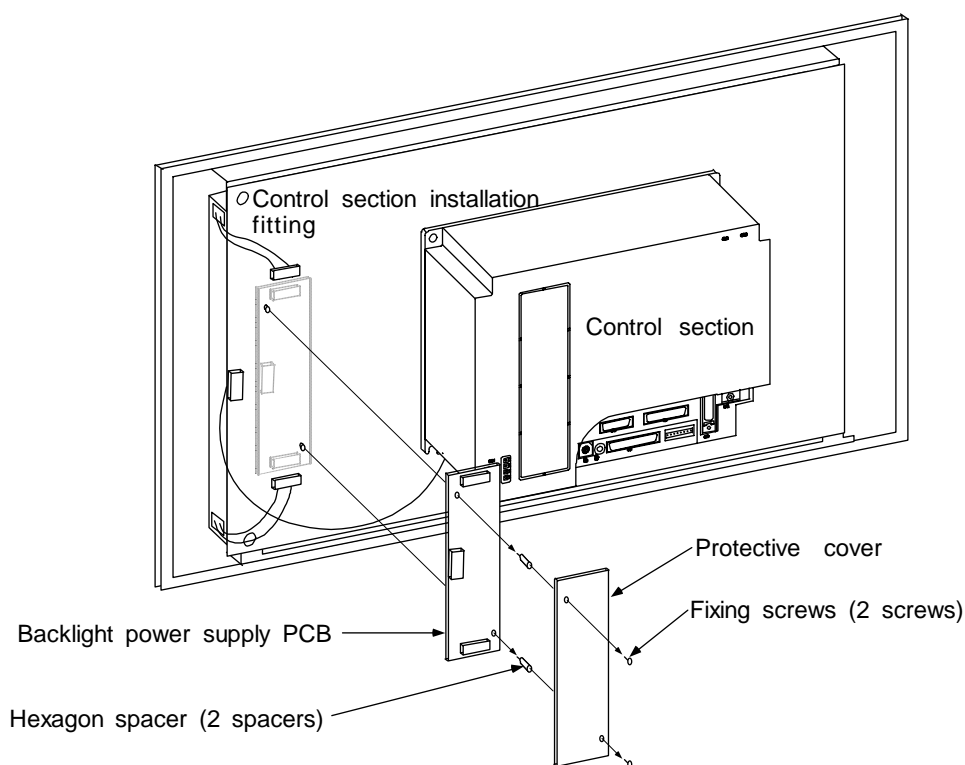
Close the operation box door.



CAUTION

-  Incorrect connections may damage the devices, so connect the cables to the specified connectors.
-  Do not replace the backlight power supply PCB while the power is ON.
-  Do not connect or disconnect the connection cables between each unit while the power is ON.

4. DAILY MAINTENANCE AND PERIODIC INSPECTION AND MAINTENANCE

4.3 Replacement Methods

(4) LCD signal interface PCB (HR273)

The LCD signal interface PCB is used to distribute the signals from the control section to the LCD panel.

This PCB has a voltage booster circuit inside for adjusting the contrast.

a) Replacement procedures

Always replace the backlight power supply PCB with the control section power turned OFF.

Check that the control section power is turned OFF. (If the power is not OFF, turn it OFF.)

Open the operation box door.

Disconnect all cables connected to the LCD signal interface PCB.

Remove the LCD signal interface PCB from the PCB fixing nylon fastener on the control section installation fitting. (Pinch the lock section of the PCB fixing nylon fastener with a pair of radio pliers, etc., to release the lock, and then remove the PCB.)

Replace with a new LCD signal interface PCB, and install the PCB onto the PCB fixing nylon fastener on the control section installation fitting. (Install the PCB by inserting the PCB fixing nylon fastener lock section into the PCB installation holes.)

Connect all cables connected to the LCD signal interface PCB. (Connect the cables to the designated connectors.)

Close the operation box door.

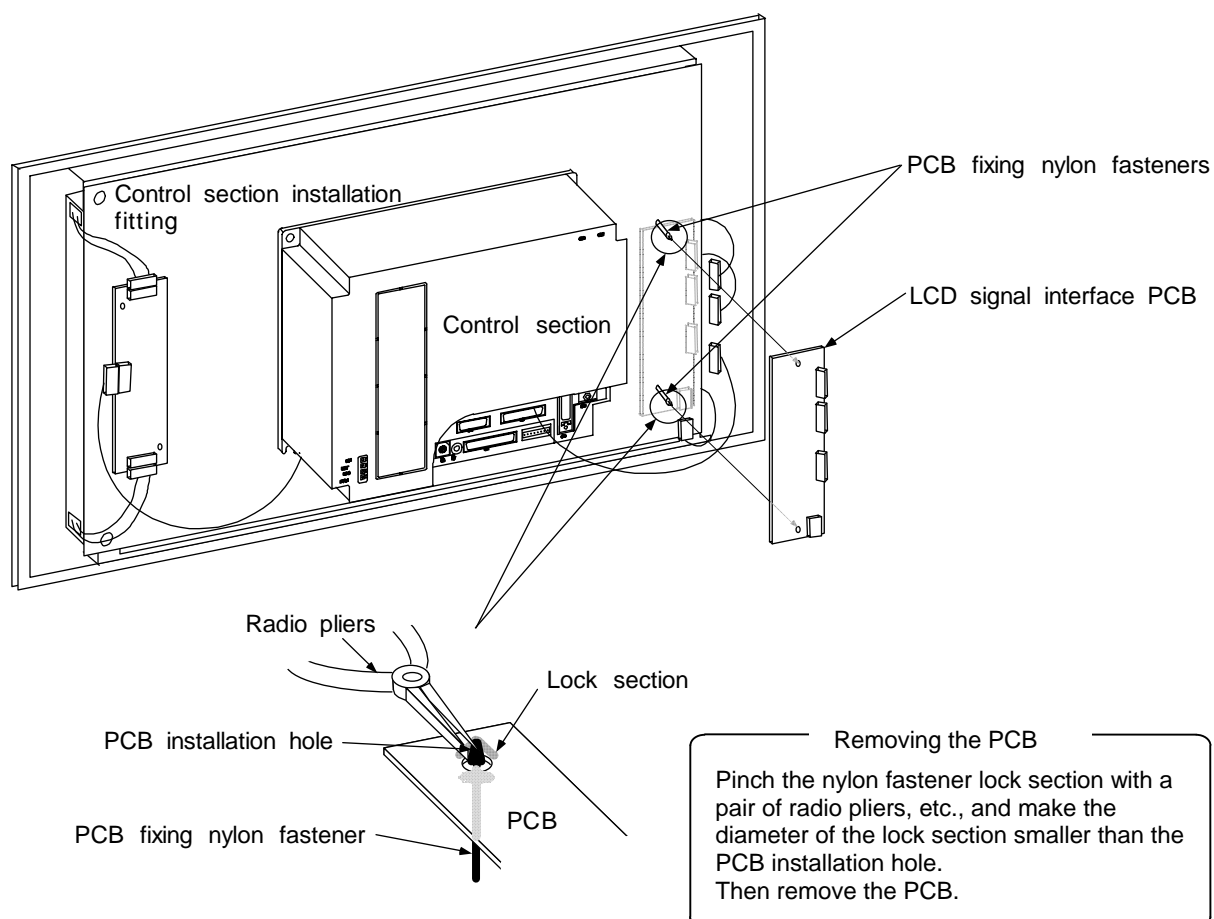

CAUTION

- ⚠ Incorrect connections may damage the devices, so connect the cables to the specified connectors.
- ⚠ Do not replace the LCD signal interface PCB while the power is ON.
- ⚠ Do not connect or disconnect the connection cables between each unit while the power is ON.

4. DAILY MAINTENANCE AND PERIODIC INSPECTION AND MAINTENANCE

4.3 Replacement Methods

(5) Expansion PCB

The expansion PCB is used to expand the system for adding a serial port, etc. (Refer to corresponding modules in section 1.1.3 and section 2, for details on the expansion PCB types and functions.)

Up to two expansion PCBs can be added. The PCBs are mounted in the slots on the right side of the control section power supply PCB.

a) Replacement procedures

Always replace the expansion PCB with the control section power turned OFF.

Check that the control section power is turned OFF. (If the power is not OFF, turn it OFF.)

Open the operation box door, and then open the front cover of the control section.

Disconnect all cables connected to the expansion PCB.

While holding the front upper and lower sections of the expansion PCB with both hands, pull out the PCB from the control section.

Replace with a new expansion PCB, and if the PCB has settings, set the settings to the same as the original PCB.



Install the expansion PCB into the control section. (Align the expansion PCB with the PCB fixing guides on the inner side of the control section case, and then install.)

Connect all cables connected to the expansion PCB. (Connect the cables to the designated connectors.)

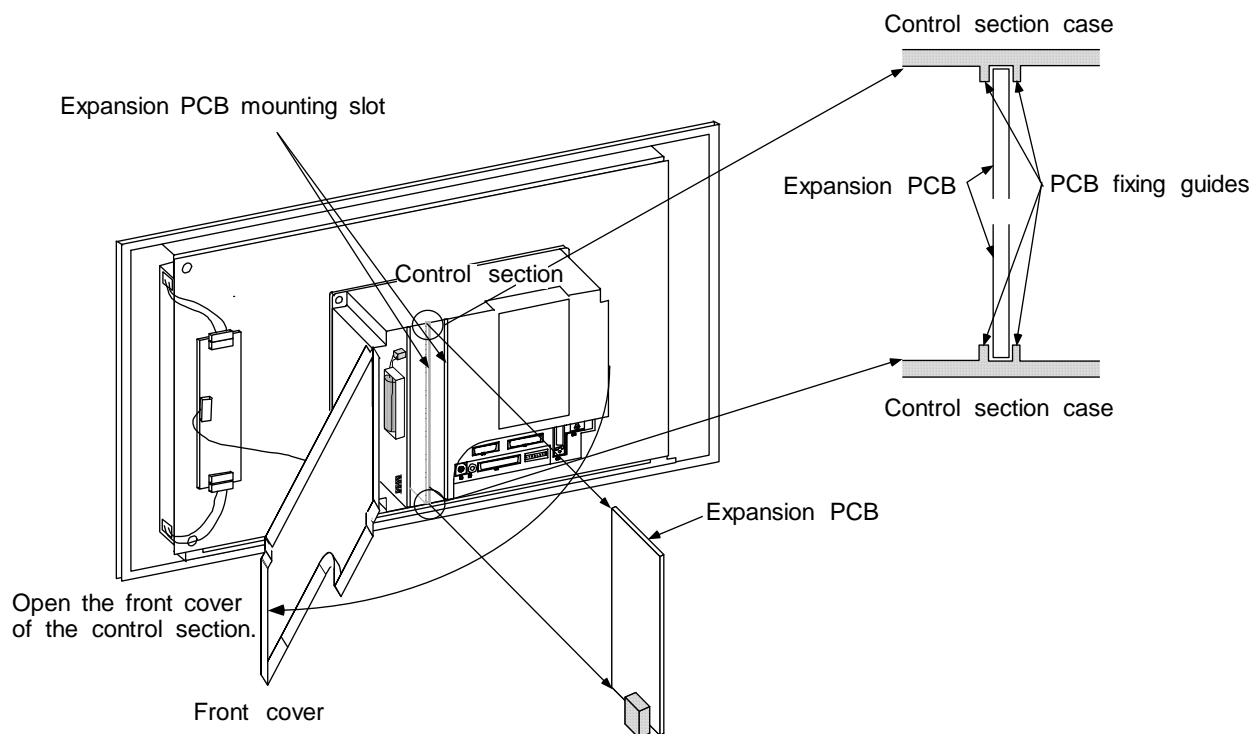
Close the front cover of the control section, and then close the operation box door.



CAUTION

-  Incorrect connections may damage the devices, so connect the cables to the specified connectors.
-  Do not replace the expansion PCB while the power is ON.
-  Do not connect or disconnect the connection cables between each unit while the power is ON.

4. DAILY MAINTENANCE AND PERIODIC INSPECTION AND MAINTENANCE

4.3 Replacement Methods

(6) Cassette memory

The cassette memory is a PCB used to store the user PLCs and machining programs, and is installed on CBUS1 of the control section. (Refer to corresponding modules in section 1.1.3 and section 2, for details on the cassette memory types and functions.)

a) Replacement procedures

Always replace the cassette memory with the control section power turned OFF.

Before replacing the RAM type cassette memory, always make a back up of the memory to be replaced using an external I/O device, etc., and then re-input the details after replacing the memory.

Check that the control section power is turned OFF. (If the power is not OFF, turn it OFF.)

Open the operation box door, and then open the front cover of the control section.



While holding the front upper and lower sections of the cassette memory with a thumb and forefinger, pull out the cassette memory from the control section.

Replace with a new cassette memory, and install into the control section. (Align the cassette memory with the cassette fixing guides on the inner side of the control section case, and then install.)

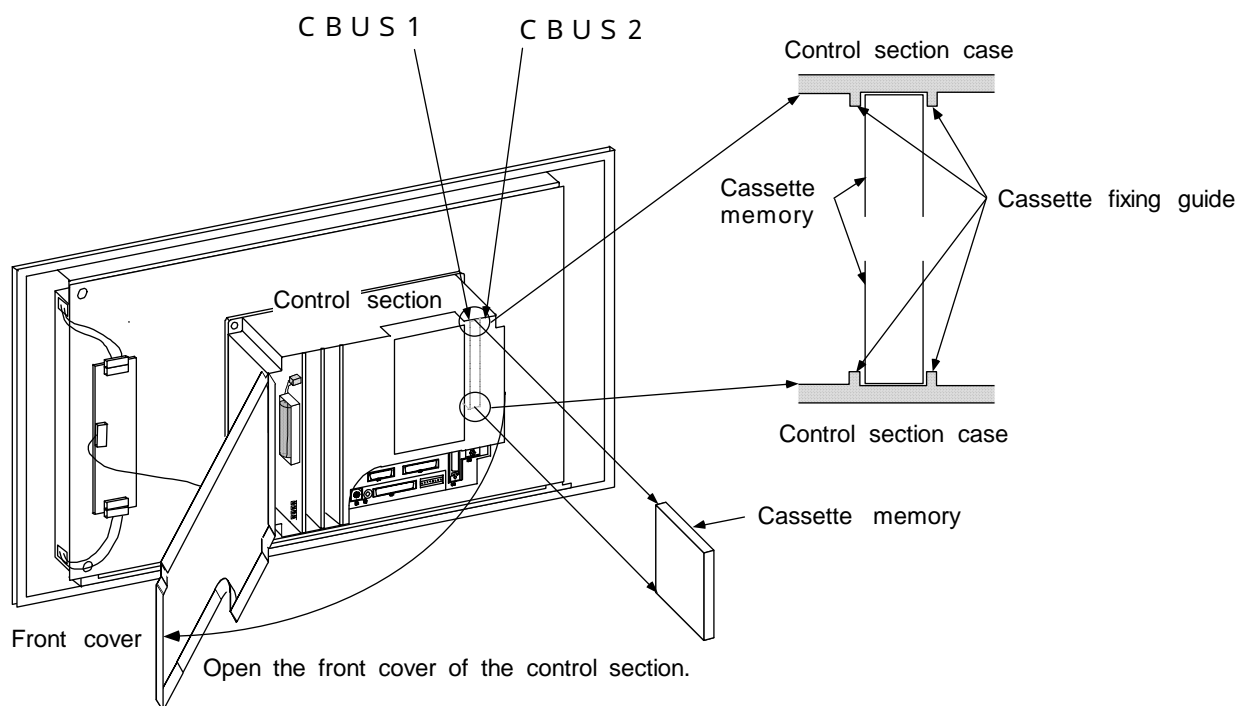
Close the front cover of the control section, and then close the operation box door.



CAUTION

-  Incorrect connections may damage the devices, so connect the cables to the specified connectors.
-  Do not replace the cassette memory while the power is ON.
-  Do not connect or disconnect the connection cables between each unit while the power is ON.

4. DAILY MAINTENANCE AND PERIODIC INSPECTION AND MAINTENANCE

4.3 Replacement Methods

(7) Card-sized I/O (HR361, HR371)

The card-sized I/O is a machine input/output interface PCB used for mounting relay PCBs, etc., in the electric cabinet onto the control PCB.

a) Replacement procedures

Always replace the card-sized I/O with the control section power turned OFF.

Check that the control section power is turned OFF. (If the power is not OFF, turn it OFF.)

Open the electric cabinet door.

Remove the card-sized I/O from the control PCB in the electric cabinet. (Open the locks of the card-sized I/O fixing guides outward to open the fixing claws, and then pull the card-sized I/O out.)



Replace with a new card-sized I/O and install onto the control PCB in the electric cabinet.

(Align the card-sized I/O with the card-sized I/O fixing guides in the control PCB, and insert until the fixing guide's lock section is securely locked.)

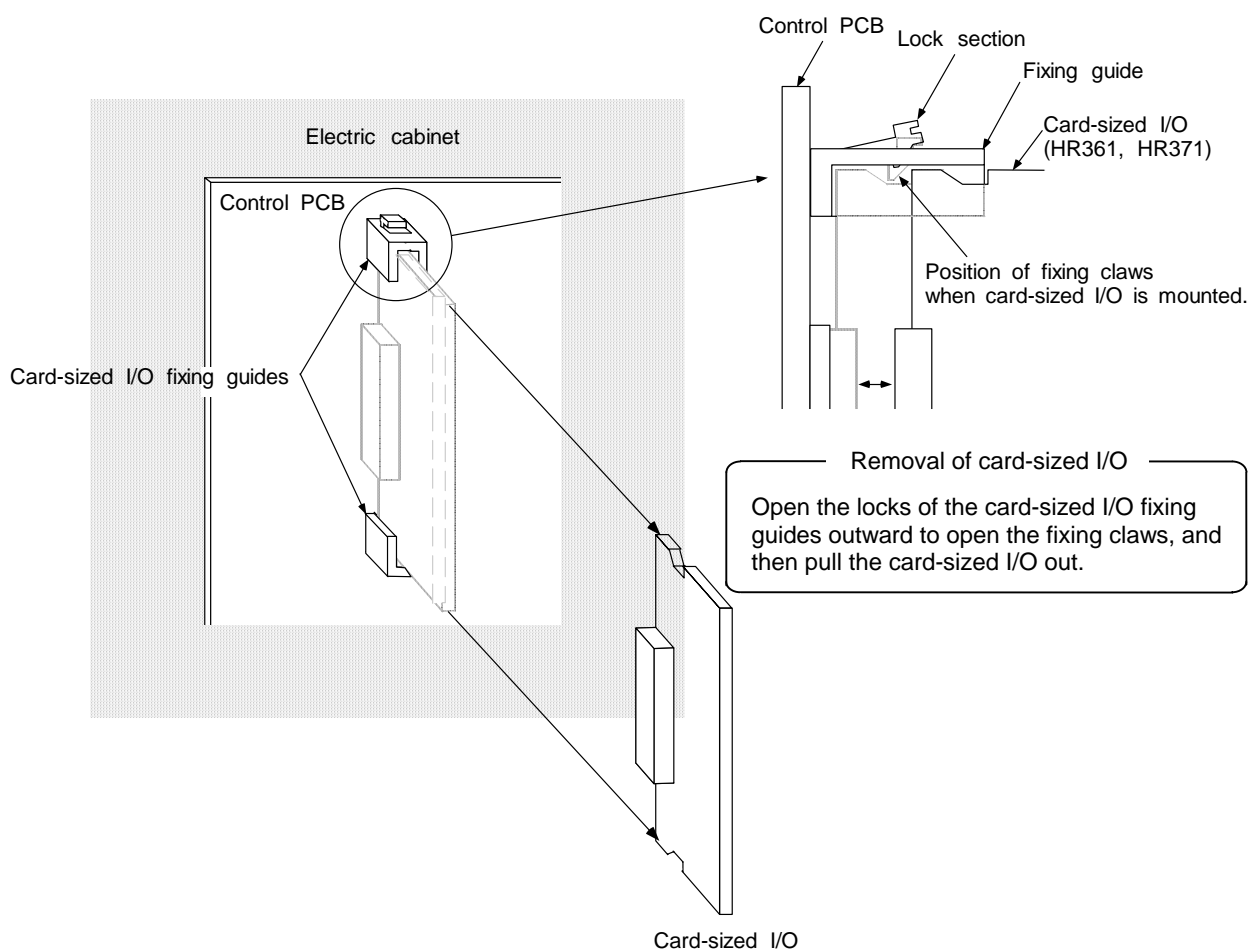
Close the electric cabinet door.



CAUTION

-  Incorrect connections may damage the devices, so connect the cables to the specified connectors.
-  Do not replace the card-sized I/O while the power is ON.
-  Do not connect or disconnect the connection cables between each unit while the power is ON.

4.4 Cleaning and Handling

4.4.1 Escutcheon

(1) Cleaning the escutcheon

Follow the same procedures as described for replacing the display section (LCD panel) in section 4.3.3 (3), and open the display section so that the rear side of the escutcheon can be cleaned.

Wipe the escutcheon with a soft clean cloth. If the escutcheon is heavily dirtied, soak the cloth in a neutral detergent, and wipe the display. Do not use alcohol or paint thinner, etc.

4.4.2 Floppy disk drive

(1) Cleaning the floppy disk drive

When the floppy disk drive is used for a long time, magnetic particles or dust from the disk may adhere onto the head surface. This can cause the reading and writing processes to be inhibited. Clean the head periodically (once every two months) with the following procedure.

a) Recommended cleaning disk

Maker : Japan Morex

Type : Morex cleaning floppy for double-sided 3.5-inch

Method: Dry

b) Cleaning method

Insert the cleaning disk into the floppy disk drive to be cleaned.

Start the cleaning program, and follow the instructions given on the screen.

When the program is completed, eject the cleaning disk.

Note 3) There is a limit to the number of times the cleaning disk can be used. When the limit is reached, replace the cleaning disk with a new one. Refer to the cleaning disk manual for the limit.

(2) Handling floppy disks

Observe the following items to ensure that the floppy disk can be used for a long time.

a) Precautions for use

Never touch the magnetic surface with hands.

Finger prints on the magnetic surface will inhibit the reading process.



Do not touch the floppy disk with hands dirtied with oil or iron chips.



Do not place the floppy disk near cigarette smoke.
Do not apply solvents on the magnetic surface.



Always attach the index label to the correct position so that it will not come off. Do not layer the index labels.



Fill in the index label before attaching it to the floppy disk.
When writing on a label already attached to the floppy disk, use a felt-tip pen, etc.

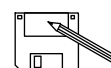

Carefully insert the floppy disk into the drive with it facing the correct direction. Rough handling during insertion and ejection could damage the floppy disk.

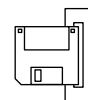

When bringing the floppy disk inside from outdoors where the temperature and humidity difference are great from indoors, wait at least 30 minutes before starting use.

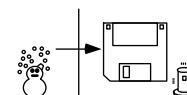

4. DAILY MAINTENANCE AND PERIODIC INSPECTION AND MAINTENANCE

4.4 Cleaning and Handling

b) Precautions for storage

Store floppy disks that are not in use and the backup floppy disks in plastic cases.

Do not place the floppy disk where it will be subject to direct sunlight or near heating appliances.

Do not place the floppy disk near magnets or items that generate strong magnetic fields. Magnetic rings and necklaces could also damage the data on the floppy disk, so avoid wearing these items when handling floppy disks.

Do not place heavy items on the floppy disk.

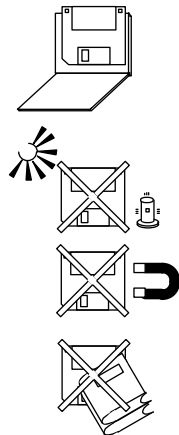

(3) Other precautions for use

a) Floppy disk drive life

The durability of the floppy disk drive is guaranteed for five years of the FDD motor rotation or 12,000 access hours, whichever is sooner. However, if used in a heavily contaminated environment, the reading and writing processes could be inhibited due to the adherence of dust or foreign matter.

Periodically clean the head to prevent this type of trouble. (Refer to section 4.4.2.)

b) Recommendation for making backups

Make copies of the floppy disks containing important data to be used in case of an accident such as damaging of the floppy disk or destruction of the data.

c) Items to observe for working conditions

The floppy disk drive and floppy disks are extremely sensitive to changes in the temperature and humidity and to dust, so always observe the precautions that have been described.

In respect to the temperature, if the working conditions are not satisfied (such as if the system is started at below freezing), the data track and head positions may deviate and prevent the data from being read properly.

In this case, wait for the internal temperature to rise.

d) Writing to floppy disks

The temperature must be 10 to 40°C when writing to the floppy disk.

Always observe the temperature conditions when writing data.

4. DAILY MAINTENANCE AND PERIODIC INSPECTION AND MAINTENANCE
4.4 Cleaning and Handling

(4) Troubleshooting

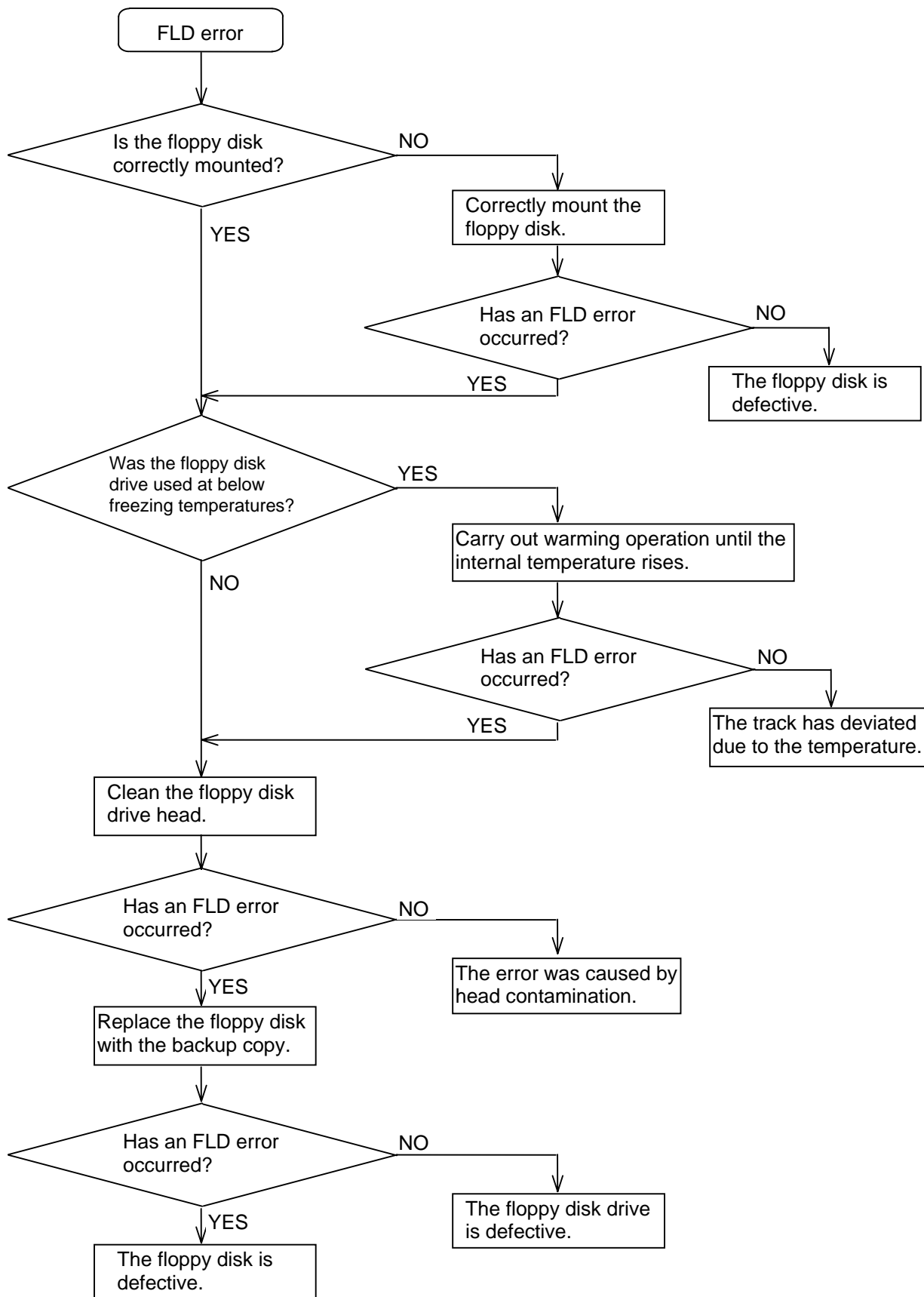

4. DAILY MAINTENANCE AND PERIODIC INSPECTION AND MAINTENANCE

4.4 Cleaning and Handling

4.4.3 Hard disk

(1) Handling the hard disk drive

- a) Precautions for use
 - Correct connect the cable.
 - Do not touch the connector section with hands or metal.
 - Do not apply excessive force on the connector section.
 - Do not drop or apply strong impacts on the drive.
 - Do not disassemble the drive.
- b) Precautions for storage
 - Avoid storing the drive in high temperature, high humidity places.
 - Do not place the drive near magnets or items that generate strong magnetic fields.

(2) Other precautions for use

- a) Recommendation for making backups
 - The hard disk is a durable part, so make a copy of the hard disk to save important data.

4.4.4 LCD panel

(1) Handling the LCD panel

- a) Precautions for use
 - The polarizing plate (display surface) of the LCD panel will scratch easily, so take care when handling.
 - Glass is used and will crack or break if dropped or contacted against hard objects. Take care when handling.
 - If water drops, etc., are left on the polarizing plate for a long time, the plate could discolor or become spotted. Wipe of any moisture immediately.
 - If the polarizing plate is contaminated, wipe it off with cotton or a soft cloth, etc.
 - A CMOS LSI is used, so take special care against static electricity when handling.
 - Never disassemble the LCD panel. Doing so could lead to damage.
- b) Precautions for storage
 - Avoid storing the LCD panel in high temperature, high humidity places. (Store within the storage temperature range.)
 - When storing the LCD panel as a single unit, make sure that other items will not contact the polarizing plate (display surface).
 - When storing the LCD panel for a long time, store it in a dark place where it will not be subject to direct sunlight or fluorescent light.

(2) Other precautions for use

- a) Backlight life
 - The life of the backlight is 10,000 hours/25°C. (Time for the brightness to drop to 50% of the initial value.)
 - The life depends on the temperature, and when used continuously at low temperatures, the life will be shorter.
- b) Brightness at startup
 - Due to the characteristics of the backlight, the brightness will drop slightly at low temperatures. It may take several minutes for the brightness to reach the rated value after the power is turned ON.
- c) Unevenness, bright spots and dark spots
 - The LCD display may have uneven brightness, small bright spots or small dark spots, but this is not a fault.
- d) Contrast
 - If the contrast of the STN method LCD panel changes due to temperature fluctuations making the panel difficult to view, open the operation box door and adjust the contrast adjustment

4. DAILY MAINTENANCE AND PERIODIC INSPECTION AND MAINTENANCE

4.4 Cleaning and Handling

potentiometer on the LCD signal interface PCB.

4.4.5 PCMCIA card

(1) Handling the PCMCIA card

The general precautions for handling the PCMCIA card are as described below.
Refer to the instruction manual of the PCMCIA card being used for details.

a) Precautions for use

- Insert the PCMCIA card with the correct direction.
- Do not touch the connector section with hands or metal.
- Do not apply excessive force on the connector section.
- Do not bend or apply strong impacts on the card.
- Do not open the cover or disassemble the card.
- Avoid use in places with high levels of dust.

b) Precautions for storage

- Avoid storing the PCMCIA card in high temperature, high humidity places.
- Avoid storing the PCMCIA card in places with high levels of dust.

Revision History

Revision	Date of revision	Revision details
*	97/10/2	First edition was issued.
A	97/11/25	Mistakes were corrected.
B	01/9/17	Design of the cover and the back cover were changed. MODEL, MODEL CODE, and Manual No. were added on the back cover.