



**DeviceNet Option Board
for use with the
VSM500 Integrated Drive/Motor**

Instruction Manual D2-3463

Rockwell
Automation

The information in this manual is subject to change without notice.

Throughout this manual, the following notes are used to alert you to safety considerations:



ATTENTION: Identifies information about practices or circumstances that can lead to personal injury or death, property damage, or economic loss.

Important: Identifies information that is critical for successful application and understanding of the product.



ATTENTION: The VSM500 unit and a DeviceNet network may contain hazardous voltage levels. Before working on the VSM500 unit or DeviceNet Option board, remove power from the drive, and verify that the VSM500 unit has discharged to safe voltage levels. Failure to observe these precautions could result severe bodily injury or loss of life.

ATTENTION: Only personnel familiar with the VSM500 unit and DeviceNet should plan or implement the installation, start-up, configuration and subsequent maintenance of the VSM500 unit. Failure to observe these precautions could result in bodily injury and/or damage to equipment.

ATTENTION: Parameter 109 [DNET FAULT MODE] and Parameter 110 [DNET IDLE MODE] determine the action of the option and connected VSM500 unit if communications are disrupted or a scanner is put in idle mode. By default, these parameters stop the VSM500 unit. You can set them so that the VSM500 unit continues to run. Precautions should be taken to ensure that the settings of these parameters do not create a hazard. Failure to observe these precautions could result in bodily injury and/or damage to equipment.

ATTENTION: When a system is configured for the first time, the motor must be disconnected from the machine or process during initial system testing. Injury or equipment damage may occur due to unintended or incorrect machine motion. Failure to observe these precautions could result in bodily injury and/or damage to equipment.

ATTENTION: The DeviceNet Option board contains ESD (Electrostatic Discharge) sensitive parts and assemblies. Component damage may result if ESD control procedures are not followed. Static control precautions are required when handling this product. If you are not familiar with static control procedures, refer to any applicable ESD protection handbook. Failure to observe these precautions could result in damage to equipment.

DeviceNet is a trademark of the Open DeviceNet Vendor Association.
RSLogix and RSNetWorx are trademarks of Rockwell Software.
Windows, Windows NT and Microsoft are trademarks of Microsoft Corporation.
VSM500 and Reliance are trademarks of Rockwell Automation.

CONTENTS

| | | |
|------------------|--|------|
| Preface | | VII |
| Chapter 1 | Getting Started | |
| 1.1 | Components | 1-1 |
| 1.2 | Option Features | 1-2 |
| 1.3 | Required Equipment..... | 1-2 |
| 1.4 | Quick Start..... | 1-3 |
| Chapter 2 | Installing the DeviceNet Option Board | |
| 2.1 | Preparing for the Installation..... | 2-1 |
| 2.2 | Complying with EMC Directive 89/336/EEC..... | 2-1 |
| 2.3 | Complying with Low Voltage Directive 73/23/EEC | 2-1 |
| 2.4 | Connecting the Option to the VSM500 Unit..... | 2-2 |
| 2.5 | Commissioning the VSM500 Unit for DeviceNet | 2-3 |
| 2.6 | Connecting the DeviceNet Option Board and VSM500 Unit to the Network ... | 2-5 |
| 2.7 | Reinstalling the Cover on the VSM500 Unit | 2-5 |
| 2.8 | Applying Power..... | 2-6 |
| Chapter 3 | Configuring the VSM500 Unit and DeviceNet Option Board | |
| 3.1 | Configuration Tools | 3-1 |
| 3.2 | Going Online with DeviceNet Manager | 3-1 |
| 3.3 | Creating an EDS File..... | 3-3 |
| 3.4 | Accessing Parameters in the VSM500 Unit and Device Option Board | 3-4 |
| 3.5 | Setting the Node Address..... | 3-5 |
| 3.6 | Setting the Data Rate | 3-6 |
| 3.7 | Selecting Input and Output Assemblies..... | 3-7 |
| 3.8 | Enabling Network Control | 3-7 |
| 3.9 | Enabling Network Speed Reference | 3-8 |
| 3.10 | Setting the Communications Fault Action..... | 3-9 |
| 3.11 | Setting the Idle Action..... | 3-10 |
| 3.12 | Setting the COS (Change of State) Mask..... | 3-10 |
| 3.13 | Resetting the Devicenet Option Board | 3-11 |
| Chapter 4 | Configuring a Scanner | |
| 4.1 | Setting Up the Scan List | 4-2 |
| 4.2 | Mapping the VSM500 Unit's Data in the Scanner | 4-5 |
| 4.2.1 | Mapping the Input I/O..... | 4-6 |
| 4.2.2 | Mapping the Output I/O..... | 4-7 |
| 4.3 | Saving the Configuration | 4-8 |
| Chapter 5 | Using I/O Messaging | |
| 5.1 | Understanding I/O Messaging and Assemblies..... | 5-1 |
| 5.2 | Example of I/O Messaging | 5-2 |
| 5.3 | Example SLC Ladder Logic Program | 5-3 |

| | | |
|-------------------|---|------------|
| Chapter 6 | Using Explicit Messaging | |
| 6.1 | About Explicit Messaging | 6-1 |
| 6.2 | Using Explicit Messaging | 6-1 |
| 6.3 | Formatting Explicit Messages | 6-2 |
| 6.4 | Example SLC Ladder Logic Program..... | 6-3 |
| | | |
| Chapter 7 | Troubleshooting | |
| 7.1 | Locating the COMM Status Indicator | 7-1 |
| 7.2 | Understanding the COMM Status Indicator | 7-2 |
| 7.3 | Fault Codes..... | 7-3 |
| 7.4 | Solving Potential Problems | 7-5 |
| | | |
| Appendix A | Technical Specifications..... | A-1 |
| | | |
| Appendix B | Parameters..... | B-1 |
| | | |
| Appendix C | DeviceNet Objects | C-1 |
| | | |
| Appendix D | Glossary | D-1 |

List of Figures

| | |
|--|------|
| Figure 1.1 – DeviceNet Option Board Components | 1-1 |
| Figure 2.1 – Removing the Cover..... | 2-2 |
| Figure 2.2 – Mounting the DeviceNet Option Board..... | 2-2 |
| Figure 2.3 – Switches on the VSM500 Drive Unit and DeviceNet Option Board..... | 2-3 |
| Figure 2.4 – Connecting a 10-Pin Linear Plug to the Cable | 2-5 |
| Figure 2.5 – Reinstalling the Cover | 2-6 |
| Figure 3.1 – DeviceNet Driver Selection Dialog Box | 3-2 |
| Figure 3.2 – Driver Configuration Dialog Box | 3-2 |
| Figure 3.3 – DeviceNet Manager in Online Mode Icon..... | 3-2 |
| Figure 3.4 – Create EDS Stub Dialog Box..... | 3-3 |
| Figure 3.5 – Load from Device Dialog Box..... | 3-3 |
| Figure 3.6 – Open Dialog Box | 3-4 |
| Figure 3.7 – Example Network Who Window | 3-4 |
| Figure 3.8 – Device Configuration - Enhanced Mode Dialog Box | 3-5 |
| Figure 3.9 – Modifying the Node Address Parameter..... | 3-5 |
| Figure 3.10 – Modifying the Data Rate Parameter | 3-6 |
| Figure 3.11 – Modifying the Output Assembly Parameter..... | 3-7 |
| Figure 3.12 – Modifying the Network Control Parameter..... | 3-8 |
| Figure 3.13 – Modifying the Speed Reference Parameter | 3-8 |
| Figure 3.14 – Modifying the Fault Action Parameter | 3-9 |
| Figure 3.15 – Modifying the Idle Action Parameter..... | 3-10 |
| Figure 3.16 – Modifying the Change of State Mask..... | 3-11 |
| Figure 3.17 – Modifying the Reset Parameter | 3-11 |
| Figure 4.1 – Example DeviceNet Network..... | 4-1 |
| Figure 4.2 – Network Who Window | 4-2 |
| Figure 4.3 – 1747-SDN Module Configuration Dialog Box | 4-2 |
| Figure 4.4 – 1747-SDN Scan List Editor Dialog Box | 4-3 |
| Figure 4.5 – Add Devices to Scan List Dialog Box | 4-3 |
| Figure 4.6 – Scan List Editor Dialog Box..... | 4-4 |
| Figure 4.7 – Edit Device I/O Parameters Dialog Box..... | 4-4 |
| Figure 4.8 – DeviceNet Manager Message | 4-5 |
| Figure 4.9 – 1747-SDN Scan List Editor Dialog Box | 4-5 |
| Figure 4.10 – Datatable Map Dialog Box..... | 4-6 |
| Figure 4.11 – Input Datatable Map | 4-6 |
| Figure 4.12 – Output Datatable Map | 4-7 |
| Figure 4.13 – Output Datatable Map | 4-7 |
| Figure 4.14 – Scan List Editor Dialog Box..... | 4-8 |
| Figure 4.15 – Scan List Editor - Download Dialog Box..... | 4-8 |
| Figure 5.1 – Example I/O Image..... | 5-2 |
| Figure 5.2 – Example SLC Ladder Logic Program..... | 5-3 |

Figure 6.1 – Explicit Message Format.....6-2
Figure 6.2 – Example SLC Ladder Logic Program6-5
Figure 7.1 – VSM500 Integrated Drive/Motor COMM Status Indicator7-1

List of Tables

| | |
|---|-----|
| Table 2.1 – Drive Setup Switch 10 Settings | 2-3 |
| Table 2.2 – DeviceNet Option Board Switch Settings (Switches 1-6) | 2-4 |
| Table 2.3 – DeviceNet Option Board Switch Settings (Switches 7-8) | 2-4 |
| Table 2.4 – Linear Plug Terminal Connections..... | 2-5 |

The purpose of this manual is to provide you with information needed to apply the DeviceNet™ option board to the VSM500 Integrated Drive/Motor. It includes methods for installing, configuring, and troubleshooting this option board. Read this manual in its entirety before installing, operating, or servicing the VSM500 Integrated Drive/Motor with a DeviceNet option board.

Audience for this Manual

This manual is intended for qualified personnel. To use the DeviceNet option, you must understand the parameters and functions of the VSM500 Integrated Drive/Motor. You must also understand DeviceNet networks, including how slave devices operate on the network and communicate with a master.

Conventions

- Parameter numbers and names are shown in bold typeface and follow the following format: **parameter XXX [*]**. The XXX represents the parameter number in the EDS file. The [*] represents the parameter name. For example, **parameter 01 [CMD FREQUENCY]**.
- Menu commands are shown in bold typeface and follow the format **Menu > Command**. For example, if you read “Select **File > Open**,” click the File menu and then click the Open command.
- The VSM500 Integrated drive/motor is also referred to as “VSM500 unit” or “unit.”
- The DeviceNet option board is also referred to as the “option board.”

Related Documentation

Refer to the following publications as necessary for more information. Most of these Rockwell Automation publications are available online from The Automation Bookstore. The URL is: <http://www.theautomationbookstore.com/>

- D2-3400 VSM500 Integrated Drive/Motor User Manual
- DN-2.5 DeviceNet Product Overview
- 1485-6.7.2 DeviceNet Cable System Planning and Installation Manual
- 1787-6.5.3 DeviceNet Manager Software User Manual
- 1771-5.14 DeviceNet Scanner Module Installation Instructions
- 1771-6.5.118 DeviceNet Scanner Module Configuration Manual
- 9399-RL53GR RSLogix 5 Getting Results Guide
- 9399-RL50GR RSLogix 500 Getting Results Guide
- 9398-DNETGR RSNetWorx for DeviceNet Getting Results Guide
- 1747-5.8 DeviceNet Scanner Module Installation Instructions
- 1747-6.5.2 DeviceNet Scanner Module Configuration Manual

Getting Assistance from Reliance Electric

If you have any questions or problems with the products described in this instruction manual, contact your local Reliance Electric sales office. For technical assistance, call 1-800-726-8112.

This chapter provides an overview of the VSM500 DeviceNet option board and the steps that you need to start using it.

1.1 Components

The following figure illustrates some of the DeviceNet option board components.

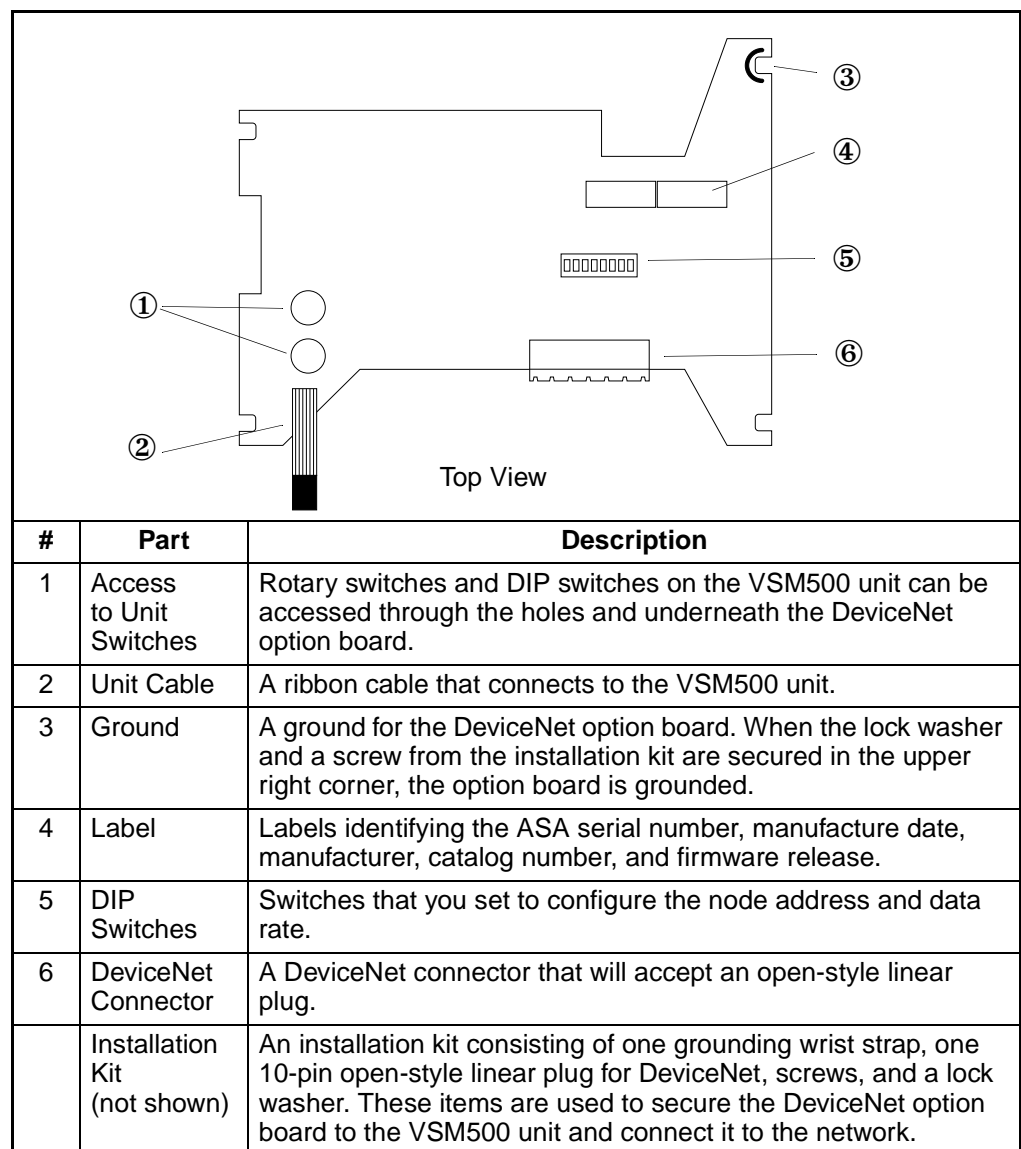

Figure 1.1 – DeviceNet Option Board Components

1.2 Option Features

The DeviceNet option board supports the following:

- Polled I/O, change of state, and cyclic data exchange
- Explicit messaging
- Explicit Unconnected Message Manager (UCMM)
- Autobaud
- Self-generating EDS files
- Faulted node recovery
- Parameters for the VSM500 unit and for the DeviceNet option board

1.3 Required Equipment

The following equipment is supplied with the DeviceNet option board. When unpacking your DeviceNet option board, verify that the package contains the following:

- DeviceNet option board
- One open-style 10-pin linear plug for DeviceNet
- Screws and a washer
- Grounding wrist strap
- This user manual

The following equipment is user-supplied. Before attempting to install or configure the DeviceNet option board, verify that you have the following:

- Small flathead and small Phillips screwdrivers
- DeviceNet cable. Refer to the DeviceNet Cable System Planning and Installation Manual.
- Tools for configuring the DeviceNet network and devices on it (e.g., a computer running DeviceNet Manager or RSNetWorx). For information on these products, refer to the Preface.
- Tools for configuring the processor and scanner on the network. For example, a computer running RSLogix5 or RSLogix500. For information on these products, refer to the Preface.

1.4 Quick Start

This quick start is for users who have previously installed and configured a DeviceNet network and Rockwell Automation drives. It may help reduce the time of installation. Because this is a start up guide for experienced users, it does not contain detailed instructions. It does, however, reference other chapters in this manual where detailed information can be found.

Important: If you have questions or are unfamiliar with a term or step, always read the referenced chapters or related documentation.

| Steps | Reference |
|--|---|
| 1 Review the Attention statements for this product. | Throughout this manual. |
| 2 Verify that you have all required equipment. | Chapter 1 |
| 3 Ensure that the VSM500 unit is correctly installed and wired. | VSM500 Integrated Drive/Motor user manual |
| 4 Install the DeviceNet option board on the VSM500 unit. Mount and secure the option on the VSM500 unit. Ground the option by using a screw and lock washer in top right corner (Figure 1.1). Then, connect the ribbon cable on the DeviceNet board to the VSM500 unit. | Chapter 2 |
| 5 Connect the DeviceNet option board to the network. Use a DeviceNet cable to connect the option to the DeviceNet network. | Chapter 2 |
| 6 Commission the VSM500 unit for the DeviceNet network. Set the switches on the drive and DeviceNet option board. On the VSM500 unit, DIP switch 10, which enables parameters, must be set to On before power is applied to the VSM500 unit. On the DeviceNet option board, the DIP switches must be set so that the VSM500 unit has a unique DeviceNet address and uses the data rate used by the network. | Chapter 2 |
| 7 Apply power to the VSM500 unit and network. Verify that the VSM500 unit is properly installed and configured (e.g., a unique node address and the correct data rate). Apply power to the network and then to the VSM500 unit. The COMM status indicator flashes green for 1/4 second, red for 1/4 second, and then goes blank while the option finishes its initialization. If the COMM status indicator goes red, there is a problem. Refer to Chapter 7 for troubleshooting information. | Chapter 2 |
| 8 Apply power to the DeviceNet master and other devices on the network. Verify that the master and network are installed and functioning in accordance with DeviceNet standards, and then apply power to them. | DeviceNet Cable System Planning and Installation Manual |
| 9 Configure the unit for your application. Use software such as RSNetWorx to set the parameters in the drive. If you set both baud rate switches to On, you must set the parameters for the node address and data rate. To receive control I/O and a reference via the DeviceNet network, you must set the parameters for start source, speed reference source, output assembly, and input assembly. In addition, you should verify that the settings of the fault mode and idle mode parameters meet the needs of your application. | Chapter 3 Appendix B |
| 10 Configure the DeviceNet scanner. Use software such as RSNetWorx to configure the scanner to communicate with the VSM500 unit. | Chapter 4 |
| 11 Create a ladder logic program. Create a ladder logic program that uses I/O to control the drive and/or explicit messages to monitor and program the drive. | Chapter 5 Chapter 6 |

Installing the DeviceNet Option Board

This chapter provides instructions for installing and wiring the DeviceNet option board on the VSM500 Integrated Drive/Motor.

Read this chapter and referenced information completely before you attempt to install or configure the DeviceNet option board. Before you apply power, review the attention statements on the inside front cover of this manual.

2.1 Preparing for the Installation

Before installing the drive, do the following:

- Read and understand the DeviceNet Cable System Planning and Installation Manual. See the Preface in this manual for how to obtain this manual.
- Read and understand the VSM500 Integrated Drive/Motor User Manual.
- Verify that you have the required equipment. Refer to Chapter 1.

2.2 Complying with EMC Directive 89/336/EEC

This product complies with Electromagnetic Compatibility (EMC) Directive 89/336/EEC when conforming with the following installation requirements:

- The essential requirements for a conforming installation for the VSM500 Integrated Drive/Motor are employed as specified in the *VSM500 Integrated Drive/Motor User Manual*.

2.3 Complying with Low Voltage Directive 73/23/EEC

This product complies with Low Voltage Directive 73/23/EEC when conforming with the following installation requirements:

- The essential requirements for a conforming installation for the VSM500 Integrated Drive/Motor are employed as specified in the VSM500 Integrated Drive/Motor User Manual.
- Review the Safety Precautions on the inside front cover of this manual and the Attention statements throughout this manual prior to installation of the option.

2.4 Connecting the Option to the VSM500 Unit



ATTENTION: A VSM500 Integrated Drive/Motor and DeviceNet network may contain voltages that can cause injury or death. Remove power from the VSM500 unit and network, and then verify that bus voltage has discharged to a zero before working on them. Failure to observe these precaution could result in severe bodily injury or loss of life.

ATTENTION: The option contains ESD (Electrostatic Discharge) sensitive parts that can be damaged if you do not follow ESD control procedures. Static control precautions are required when handling the drive. If you are unfamiliar with static control procedures, refer to any applicable ESD protection handbook. Failure to observe these precaution could result in damage to equipment.

- Step 1. Verify that power has been removed from the VSM500 unit and network.
- Step 2. Use static control precautions.
- Step 3. Remove the cover on the VSM500 unit by loosening the four cover screws (see figure 2.1). The display cable is designed to disconnect when the cover is removed.

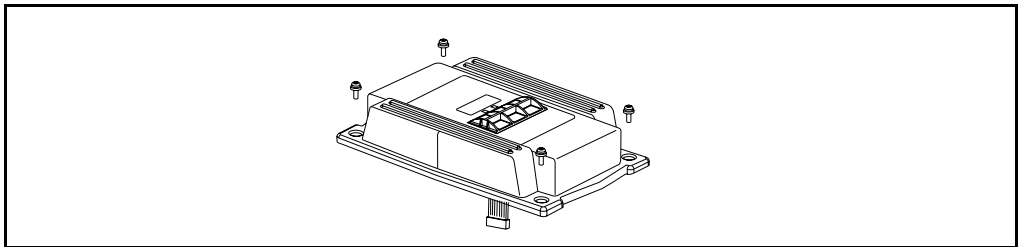

Figure 2.1 – Removing the Cover

- Step 4. Mount the DeviceNet option board. Tighten all screws to 2.6 Nm (23 in-lb.). Use the washer in the location shown in figure 2.2 to ground the option board.
- Step 5. Connect the unit cable on the DeviceNet option board to connector P3 on the VSM500 unit. Connector P3 is next to the control signal terminal block.

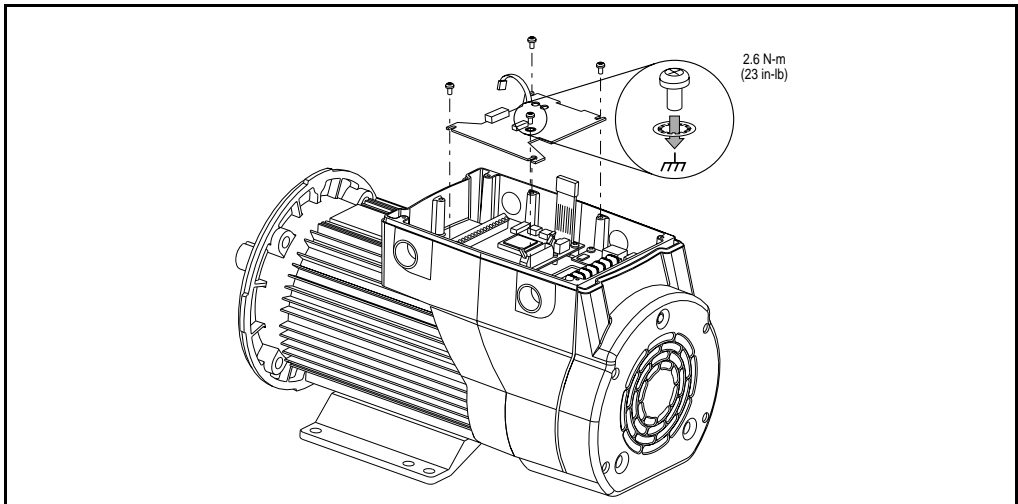

Figure 2.2 – Mounting the DeviceNet Option Board

Step 6. Before reconnecting the cover (shown in figure 2.5), commission the VSM500 unit and connect it to the network (instructions in sections 2.5 and 2.6).

2.5 Commissioning the VSM500 Unit for DeviceNet



ATTENTION: Pen ink or pencil lead may damage the switches on the DeviceNet option board. Do not use a pen or pencil to set the switches. Failure to observe these precaution could result in damage to equipment.

Step 1. Verify that power has been removed from the VSM500 unit and network.

Step 2. On the VSM500 Integrated drive/motor, set the drive setup DIP switch in position 10. The setting takes effect when the VSM500 unit first receives power. Cycle power after changing this setting.

Table 2.1 – Drive Setup Switch 10 Settings

| Setting | Description |
|---------|--|
| 0 (OFF) | VSM500 unit uses settings of DIP switches and rotary switches. You can use DeviceNet only for monitoring the VSM500 unit. |
| 1 (ON) | VSM500 unit uses settings of parameters in EEPROM. You can use DeviceNet to program, control, and monitor the VSM500 unit. |

Important: The drive requires a stop input at the control terminal bock, regardless of the setting of **parameter 34 [START SOURCE]**.

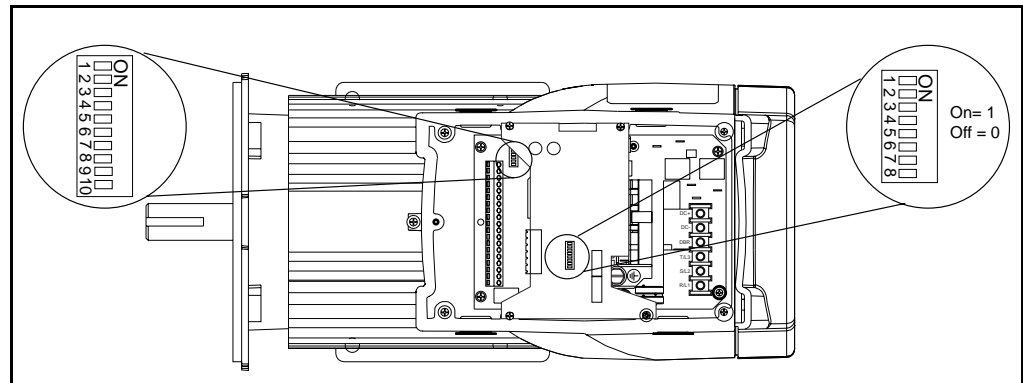

Figure 2.3 – Switches on the VSM500 Drive Unit and DeviceNet Option Board

Step 3. On the DeviceNet option board, set switches 6 through 1 to a unique DeviceNet address between 0 and 63. The default switch setting is 63.

Table 2.2 – DeviceNet Option Board Switch Settings (Switches 1-6)

| Node Address ¹ | Switch 6 ----> 1 | Node Address ¹ | Switch 6 ----> 1 | Node Address ¹ | Switch 6 ----> 1 | Node Address ¹ | Switch 6 ----> 1 |
|---------------------------|------------------|---------------------------|------------------|---------------------------|------------------|---------------------------|------------------|
| 0 | 000000 | 16 | 010000 | 32 | 100000 | 48 | 110000 |
| 1 | 000001 | 17 | 010001 | 33 | 100001 | 49 | 110001 |
| 2 | 000010 | 18 | 010010 | 34 | 100010 | 50 | 110010 |
| 3 | 000011 | 19 | 010011 | 35 | 100011 | 51 | 110011 |
| 4 | 000100 | 20 | 010100 | 36 | 100100 | 52 | 110100 |
| 5 | 000101 | 21 | 010101 | 37 | 100101 | 53 | 110101 |
| 6 | 000110 | 22 | 010110 | 38 | 100110 | 54 | 110110 |
| 7 | 000111 | 23 | 010111 | 39 | 100111 | 55 | 110111 |
| 8 | 001000 | 24 | 011000 | 40 | 101000 | 56 | 111000 |
| 9 | 001001 | 25 | 011001 | 41 | 101001 | 57 | 111001 |
| 10 | 001010 | 26 | 011010 | 42 | 101010 | 58 | 111010 |
| 11 | 001011 | 27 | 011011 | 43 | 101011 | 59 | 111011 |
| 12 | 001100 | 28 | 011100 | 44 | 101100 | 60 | 111100 |
| 13 | 001101 | 29 | 011101 | 45 | 101101 | 61 | 111101 |
| 14 | 001110 | 30 | 011110 | 46 | 101110 | 62 | 111110 |
| 15 | 001111 | 31 | 011111 | 47 | 101111 | 63 | 111111 |

¹If switches 7 and 8 are both On (1), then the DeviceNet option board uses the node address from **parameter 103 [NV MAC ID]**. The default parameter setting is 63.

Step 4. On the DeviceNet option board, set switches 7 and 8 to select the data rate at which the network is operating. The default switch setting is to use the setting of **parameter 104 [NV BAUD RATE]**.

Table 2.3 – DeviceNet Option Board Switch Settings (Switches 7-8)

| Data Rate | Switch 8 | Switch 7 |
|---|----------|----------|
| 125 kBPS | 0 | 0 |
| 250 kBPS | 0 | 1 |
| 500 kBPS | 1 | 0 |
| Set by parameter 104 [NV BAUD RATE] ¹ | 1 | 1 |

¹The default parameter setting is autobaud.

2.6 Connecting the DeviceNet Option Board and VSM500 Unit to the Network

Step 1. Verify that power has been removed from the VSM500 unit and network.

Step 2. Connect a DeviceNet cable to the network.

Important: Maximum cable length depends on data rate. Refer to the DeviceNet Cable System Planning and Installation Manual.

Step 3. Connect a Linear plug to the DeviceNet cable.

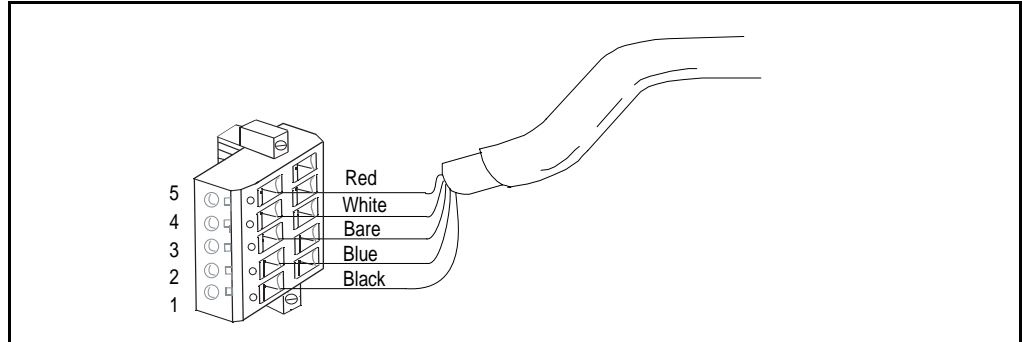

Figure 2.4 – Connecting a 10-Pin Linear Plug to the Cable

Table 2.4 – Linear Plug Terminal Connections

| Terminal | Color | Signal | Function |
|----------|-------|--------|--------------|
| 5 | Red | VDC+ | Power Supply |
| 4 | White | CAN_H | Signal High |
| 3 | Bare | SHIELD | Shield |
| 2 | Blue | CAN_L | Signal Low |
| 1 | Black | COMM | Common |

Step 4. Connect the DeviceNet cable to the VSM500 unit. Figure 2.5 shows an example.

2.7 Reinstalling the Cover on the VSM500 Unit



ATTENTION: The cover screws must be securely tightened in order to properly ground the cover. Verify that all four cover screws are tightened to 1.46 Nm (13 in-lb) before applying power to the VSM500 unit. Failure to observe this precaution could result in severe bodily injury or loss of life.

Step 1. Connect the display cable and install the cover (see figure 2.5).

Step 2. Tighten the screws on the cover to 1.46 Nm (13 in-lb).

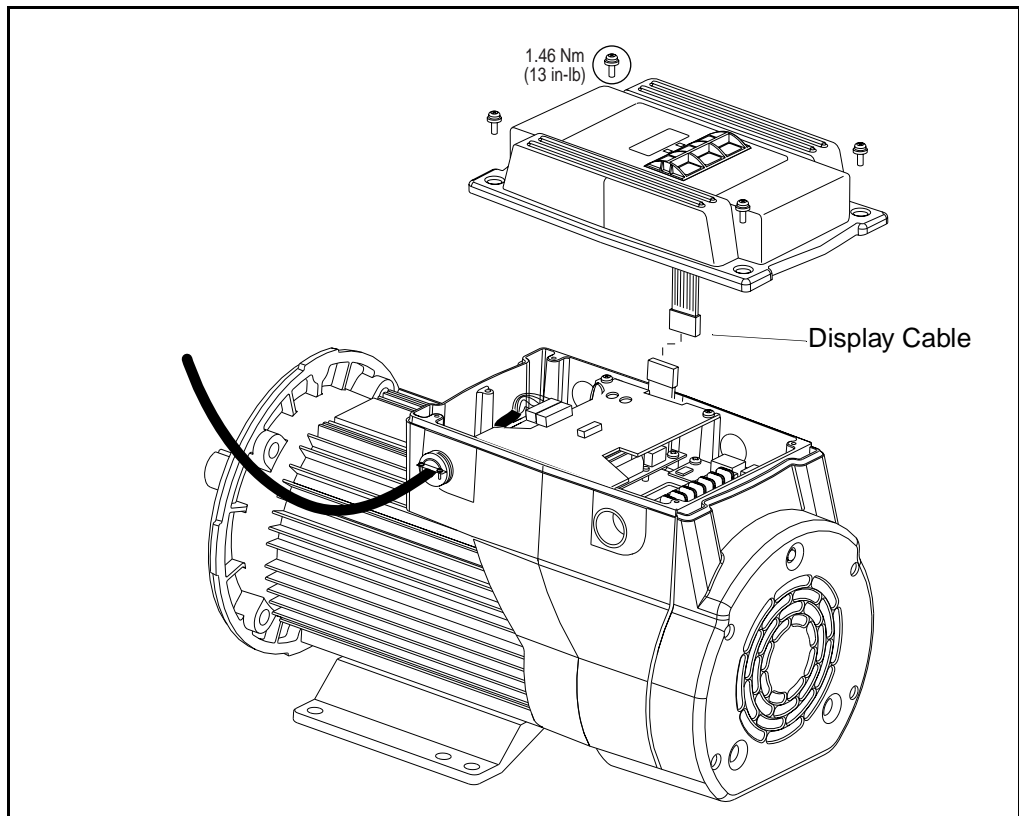

Figure 2.5 – Reinstalling the Cover

2.8 Applying Power



ATTENTION: Unpredictable operation may occur if you fail to verify that connections and switch settings are compatible with your application. Verify that connections and parameter settings are compatible with your application before applying power to the VSM500 unit. Failure to observe this precaution could result in severe bodily injury or loss of life.

- Step 1. Apply power to the network.
- Step 2. Apply power to the VSM500 unit. The DeviceNet option board receives its power from the VSM500 unit and from the network. When you apply power to the option board for the first time, the COMM status indicator flashes green for 1/4 second, red for 1/4 second, and then turns off while the option board finishes its initialization. If it stays red, there is a problem. Refer to chapter 7 for troubleshooting information.
- Step 3. Verify that the option board is set for the correct data rate and has a unique node address. If a new data rate or address is needed, reconfigure the option board switches (see section 2.5). If switches 7 and 8 are On, create a point-to-point connection to the option board with a configuration tool to set its data rate and node address parameters (see chapter 3).
- Step 4. Apply power to the master device (scanner) and other network devices.

Configuring the VSM500 Unit and DeviceNet Option Board

This chapter provides information and instructions for configuring the VSM500 Integrated drive/motor and DeviceNet option board to communicate on a DeviceNet network.

This chapter does not contain information on all possible configurations. Refer to Appendix B in this manual for a complete list of parameters. Refer to the VSM500 Integrated Drive/Motor User Manual for information on configuring the VSM500 unit.

Important: In order to configure a VSM500 unit and DeviceNet option board, they must be properly installed, commissioned for the DeviceNet network, and powered (see chapter 2).

3.1 Configuration Tools

The VSM500 Integrated drive/motor and DeviceNet option board act as a single device on the DeviceNet network. You can determine how it behaves by setting parameters using DeviceNet Manager or RSNetWorx for DeviceNet as a software configuration tool.

This manual contains instructions for using DeviceNet Manager with a VSM500 unit and SLC scanner. Note that explicit messaging can also be used to configure the VSM500 unit and DeviceNet option board. Refer to chapter 6.

3.2 Going Online with DeviceNet Manager

You can configure a VSM500 unit/DeviceNet option board device offline and then download the configuration, or you can configure it online. We recommend configuring it online.

Step 1. Start DeviceNet Manager.

Step 2. Select **Utilities > Set Up Online Connection** to display the DeviceNet Driver Selection dialog box.

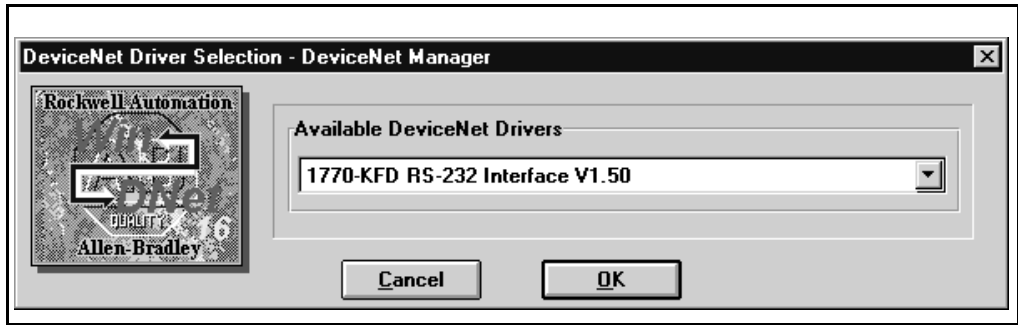

Figure 3.1 – DeviceNet Driver Selection Dialog Box

Step 3. Under Available DeviceNet Drivers, select a DeviceNet driver, and then click **OK**. The Driver Configuration dialog box appears.

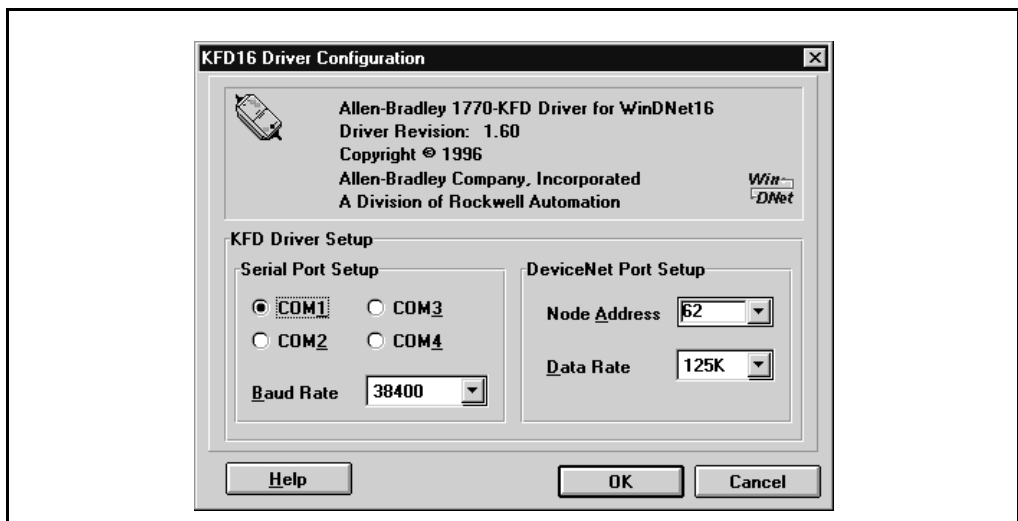

Figure 3.2 – Driver Configuration Dialog Box

Step 4. Select the appropriate settings for the following:

| Box | Description |
|-------------------|---|
| Serial Port Setup | Select the communications port on your computer to which the DeviceNet adapter is connected. |
| Baud Rate | Select the baud rate that is used by your computer communications port. |
| Node Address | Type a unique node address for the computer on the DeviceNet network. Usually, computers use the node address 62. Do not use 63 because this is the factory-default setting for new devices on the network. |
| Data Rate | Select the data rate that devices on the DeviceNet network are using. |

Step 5. Click **OK** to go online. The online icon is displayed under Comm in the lower right corner of the main window.

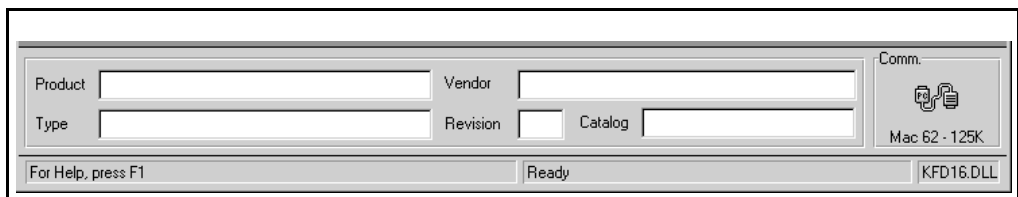

Figure 3.3 – DeviceNet Manager in Online Mode Icon

3.3 Creating an EDS File

After you go online, you can download an EDS (Electronic Data Sheet) file from any device on the network. An EDS file is a specially formatted ASCII file that provides all the information necessary for a configuration tool such as DeviceNet Manager to access and edit the parameters in a device. To create an EDS file for a VSM500 unit with a DeviceNet option board:

Step 1. Select **Utilities > Create EDS Stub** to display the Create EDS Stub dialog box.

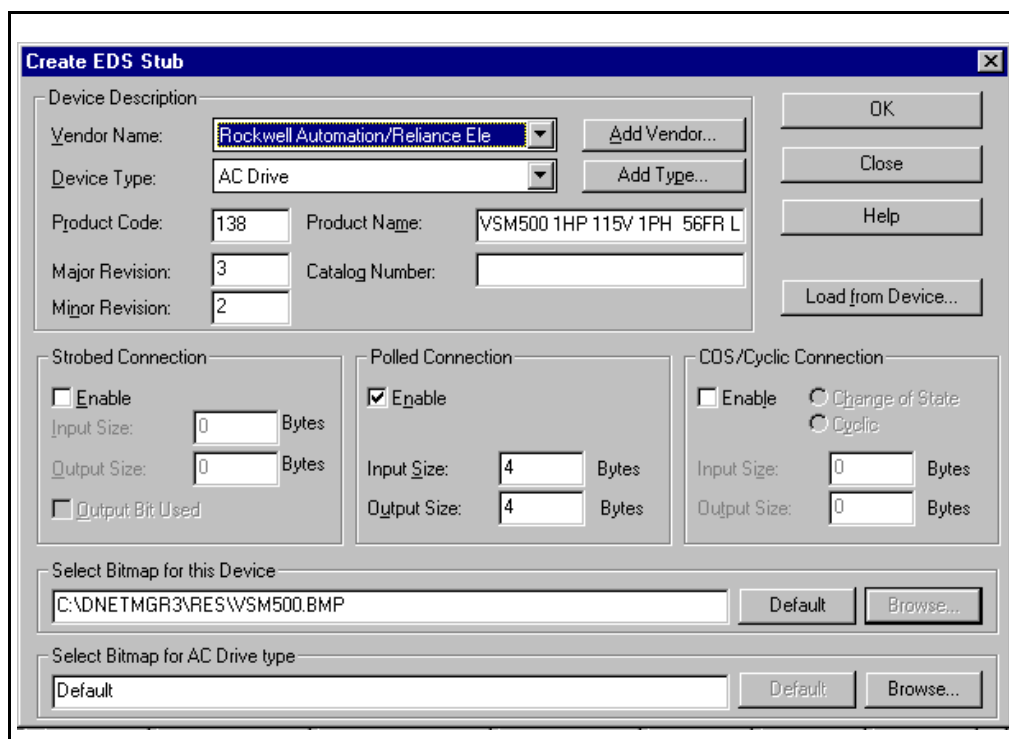

Figure 3.4 – Create EDS Stub Dialog Box

Step 2. Under Polled Connection, select **Enable** (a check appears), type **4** into the Input Size box, and type **4** into the Output Size box.

Step 3. Click **Load from Device**. The Load from Device dialog box appears.

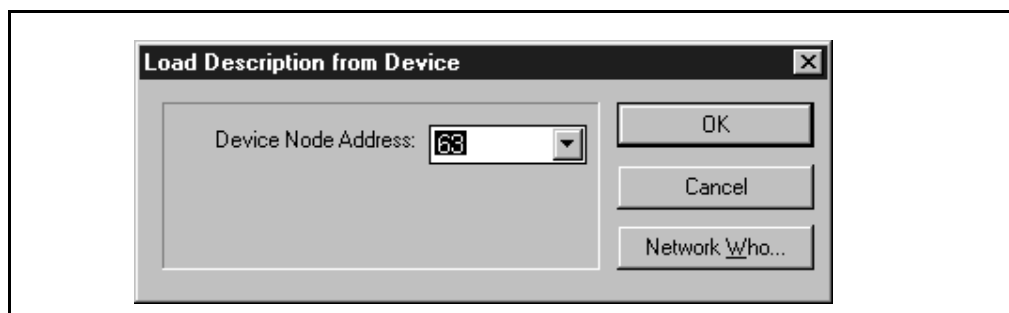

Figure 3.5 – Load from Device Dialog Box

Step 4. Type the node address of the VSM500 unit and DeviceNet option board, and then click **OK**. DeviceNet Manager downloads an EDS file. When it is finished, the Create EDS Stub dialog box reappears.

Step 5. Under Select Bitmap for this Device in the Create EDS Stub dialog box (see figure 3.4), click **Browse**. An Open dialog box appears.

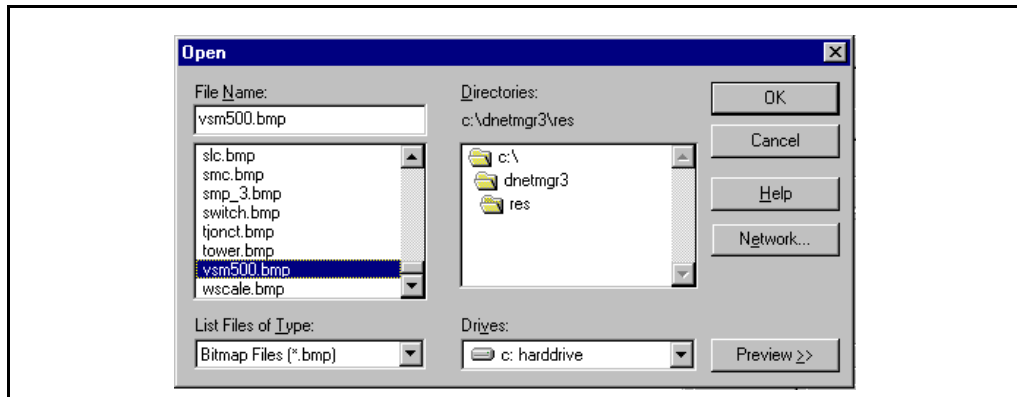

Figure 3.6 – Open Dialog Box

- Step 6. Select the **VSM500.bmp** in the list box, and then click **OK**. The Create EDS Stub dialog box reappears.
- Step 7. Click **OK**. A DeviceNet Manager message box appears and asks if you want to save the EDS file to the EDS library.
- Step 8. Click **OK** to save the EDS file. The EDS Description dialog box appears.
- Step 9. Type a description (if desired), and then click **OK**. The EDS file, description (if added), and icon that represents the VSM500 unit are saved. The new icon will appear the next time you scan the network.

3.4 Accessing Parameters in the VSM500 Unit and Device Option Board

The parameters in the VSM500 unit and the connected DeviceNet option board can be accessed with DeviceNet Manager. To access parameters:

- Step 1. Select **Who > Network Who**. The Network Who window appears, and DeviceNet Manager scans the network for devices. You can wait for it to scan the entire network, or click Stop after it displays your VSM500 unit.

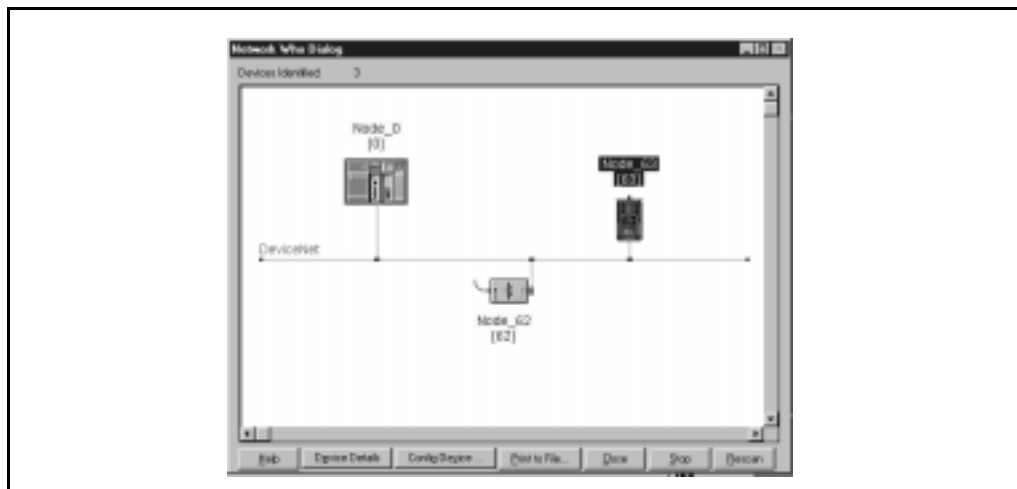

Figure 3.7 – Example Network Who Window

Step 2. Double-click the icon for the VSM500 unit. The Device Configuration - Enhanced Mode dialog box appears.

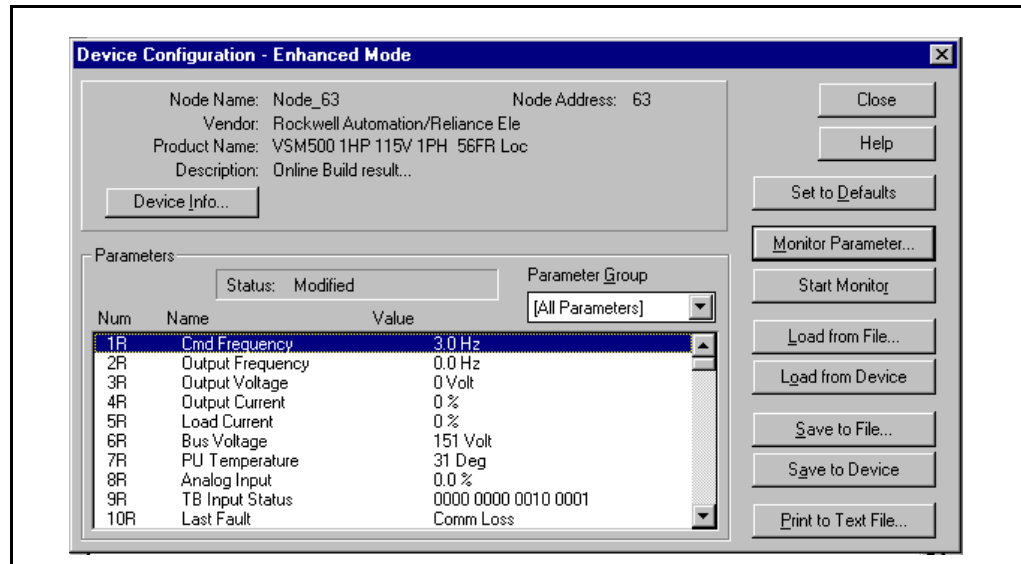

Figure 3.8 – Device Configuration - Enhanced Mode Dialog Box

Parameters for the VSM500 unit and DeviceNet option board are displayed under Parameters. You can either scroll through the parameters in the list, or you can select a specific group of parameters in the Parameter Group box. Appendix B contains a complete list of the parameters and parameter groups for the VSM500 unit and DeviceNet option board.

3.5 Setting the Node Address

If switches 7 and 8 on the DeviceNet option board are On, the value of parameter 103 [NV MAC ID] determines the node address. By default, this parameter sets the node address to 63. We recommend changing the node address to a new, unique node address because all new devices use 63 as a default node address.

Step 1. In the Device Configuration - Enhanced Mode dialog box (see figure 3.8), double-click **parameter 103 [NV MAC ID]**. The Device Configuration - Modify Numeric Parameter dialog box appears.

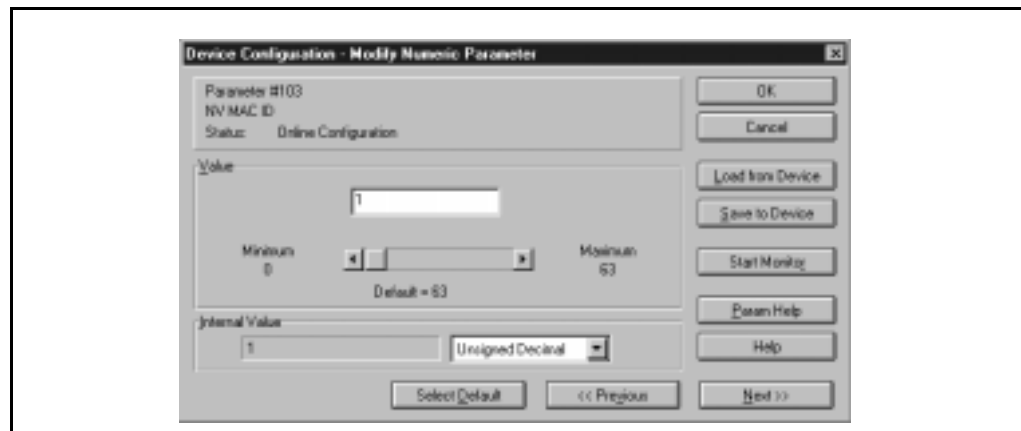

Figure 3.9 – Modifying the Node Address Parameter

- Step 2. Type a unique node address, and then click **Save to Device**.
- Step 3. Click **OK** to close the dialog box.
- Step 4. Reset the DeviceNet option board. The new setting for this parameter will take effect after a reset. See section 3.13 for more information.

After setting a new node address, you must scan the network. DeviceNet Manager will then display the new address in the Network Who window (see figure 3.7) and be able to communicate with the drive so that future parameter changes take place.

3.6 Setting the Data Rate

If switches 7 and 8 on the DeviceNet option board are On, the value of parameter 104 [NV BAUD RATE] determines the data rate at which the unit communicates on the network. By default, this parameter sets the data rate to autobaud. If another device on the network is setting a specific DeviceNet data rate, use autobaud to automatically set the adapter to it. Otherwise, you must set the parameter to the data rate at which the network is operating.

- Step 1. In the Device Configuration - Enhanced Mode dialog box (see figure 3.8), double-click **parameter 104 [NV BAUD RATE]**. The Device Configuration - Modify Enumerated Parameter dialog box appears.

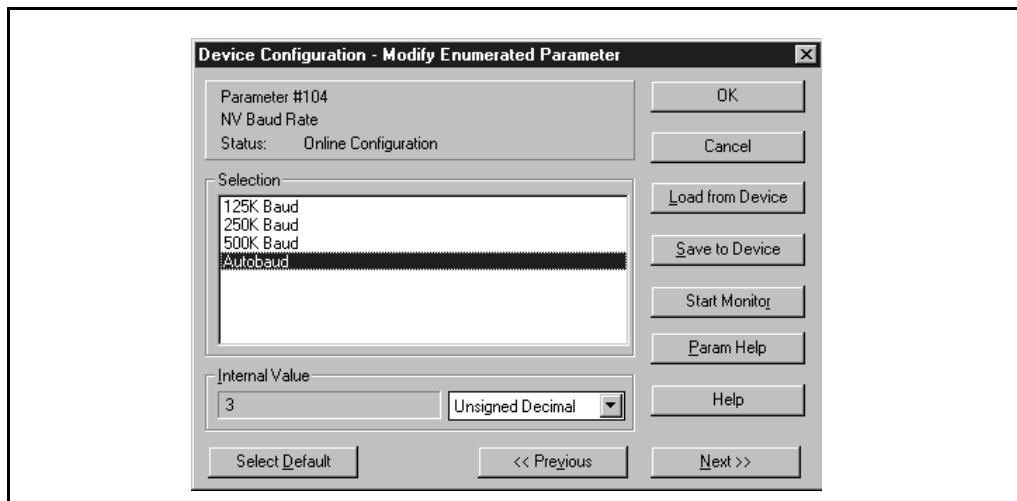

Figure 3.10 – Modifying the Data Rate Parameter

- Step 2. Select the data rate at which the network is operating or autobaud, and then click **Save to Device**.
- Step 3. Click **OK** to close the dialog box.
- Step 4. Reset the DeviceNet option board. The new setting for this parameter will take effect after a reset. See section 3.13. See section 3.13 for more information.
- Step 5. The VSM500 unit will fault after it is reset because it will not be operating at the same data rate as other devices (e.g., the computer) on the network. Clear the fault.

Communications with DeviceNet Manager will be disrupted because the VSM500 unit and DeviceNet Manager will not be operating at the same data rate. Disconnect the software and then reconnect at the new data rate.

3.7 Selecting Input and Output Assemblies

The VSM500 unit uses Assembly Objects to send data to and from a scanner over an I/O connection. The terms *input* and *output* are defined from the scanner's point of view. An output assembly is the information that is *output* by the scanner and consumed by the VSM500 unit. An input assembly is the status data that is sent by the VSM500 unit and consumed as *input* by the scanner. Refer to Chapter 5 for a discussion on control I/O and assemblies.

DeviceNet **parameters 107 [OUTPUT ASSEMBLY]** and **108 [INPUT ASSEMBLY]** must be set with the output or input assembly for your system.

Step 1. In the Device Configuration - Enhanced Mode dialog box (see figure 3.8), double-click **parameter 107 [OUTPUT ASSEMBLY]**. The Device Configuration - Modify Numeric Parameter dialog box appears.

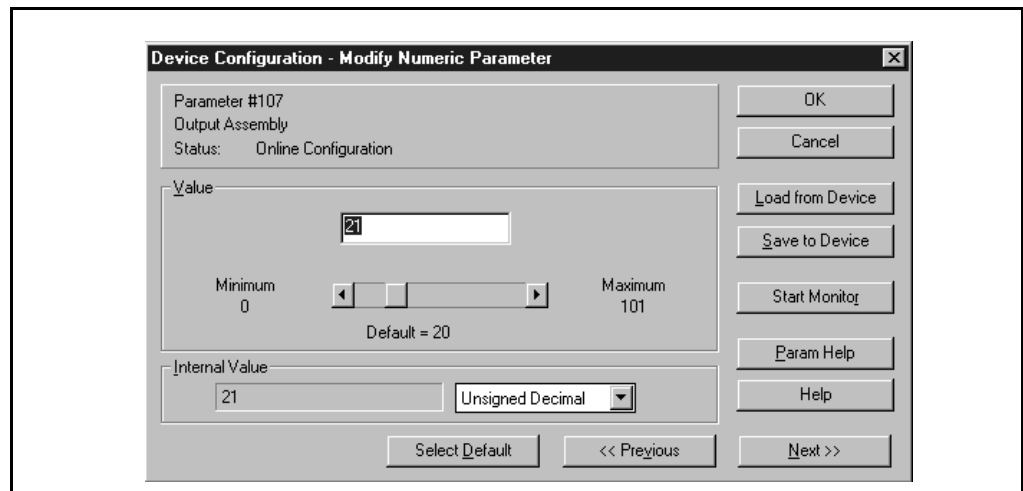

Figure 3.11 – Modifying the Output Assembly Parameter

Step 2. Select the desired assembly number, and then click **Save to Device**. Refer to the Parameter List in Appendix B for a list of values.

Step 3. Click **OK** to close the dialog box.

Step 4. Repeat steps 1 through 3 for **parameter 108 [INPUT ASSEMBLY]**.

3.8 Enabling Network Control

In order for a scanner to control the VSM500 unit (e.g., start or stop), the VSM500 unit must be configured to accept commands from the network.



ATTENTION: Changing the source of control may cause unpredictable network conditions, resulting in equipment damage, injury, or death. Ensure that you understand how a change affects your application. Failure to observe these precautions could result in severe bodily injury or loss of life.

Important: The drive requires a stop input at the control terminal block, regardless of the setting of **parameter 34 [START SOURCE]**.

Step 1. In the Device Configuration - Enhanced Mode dialog box (see figure 3.8), double-click **parameter 34 [START SOURCE]**. The Device Configuration - Modify Enumerated Parameter dialog box appears.

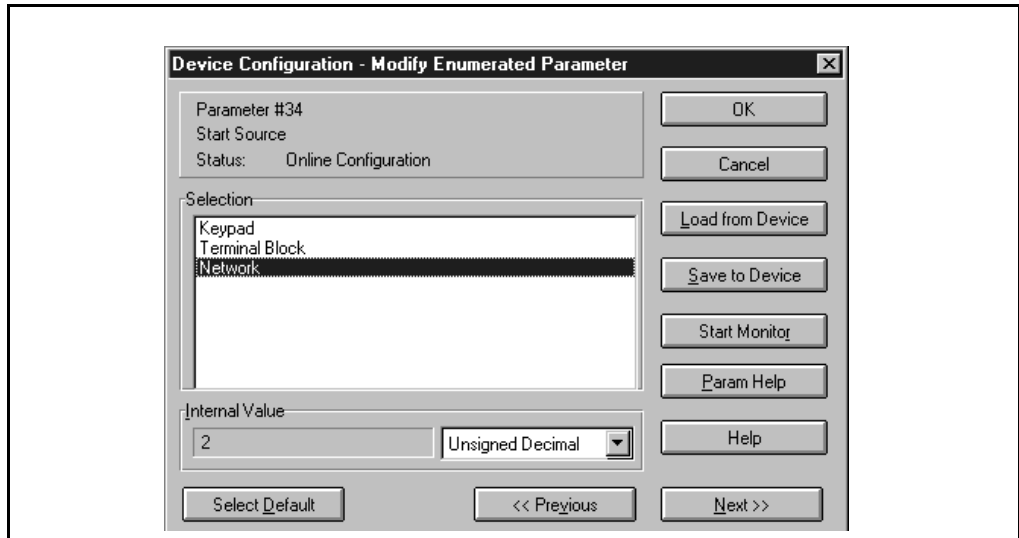

Figure 3.12 – Modifying the Network Control Parameter

Step 2. Select **Network**, and then click **Save to Device**.

Step 3. Click **OK** to close the dialog box.

3.9 Enabling Network Speed Reference

In order for a scanner to change the speed of the VSM500 unit, the unit must be configured to accept its speed reference from the network.

Step 1. In the Device Configuration - Enhanced Mode dialog box (see figure 3.8), double-click **parameter 36 [SPEED REF SOURCE]**. The Device Configuration - Modify Enumerated Parameter dialog box appears.

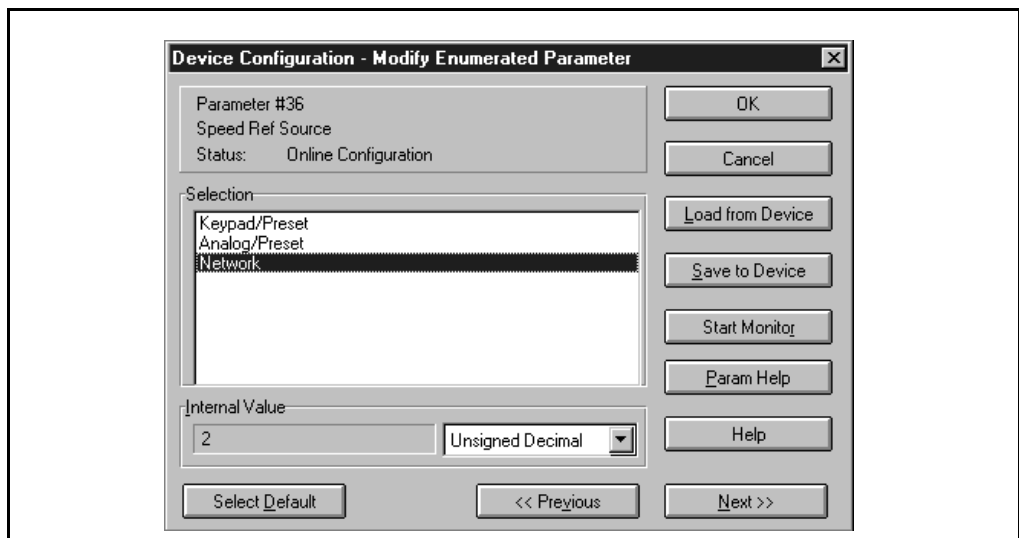



Figure 3.13 – Modifying the Speed Reference Parameter

Step 2. Select **Network**, and then click **Save to Device**.

Step 3. Click **OK** to close the dialog box.

3.10 Setting the Communications Fault Action

The communications fault action determines how the VSM500 unit and DeviceNet option board respond when communications are disrupted (e.g., disconnected cable). By default, the VSM500 unit is faulted and stopped. You can change this setting if your application requires a different setting.



ATTENTION: Parameter 109 [DNET FAULT MODE] determines the action of the option and connected VSM500 unit if communications are disrupted. By default, this parameter faults and stops the VSM500 unit. You can set this parameter so that the VSM500 unit continues to run. Precautions should be taken to ensure that the setting of this parameter does not create a hazard of injury or equipment damage. Failure to observe these precautions could result in bodily injury or damage to equipment.

Step 1. In the Device Configuration - Enhanced Mode dialog box (see figure 3.8), double-click **parameter 109 [DNET FAULT MODE]**. The Device Configuration - Modify Boolean Parameter dialog box appears.

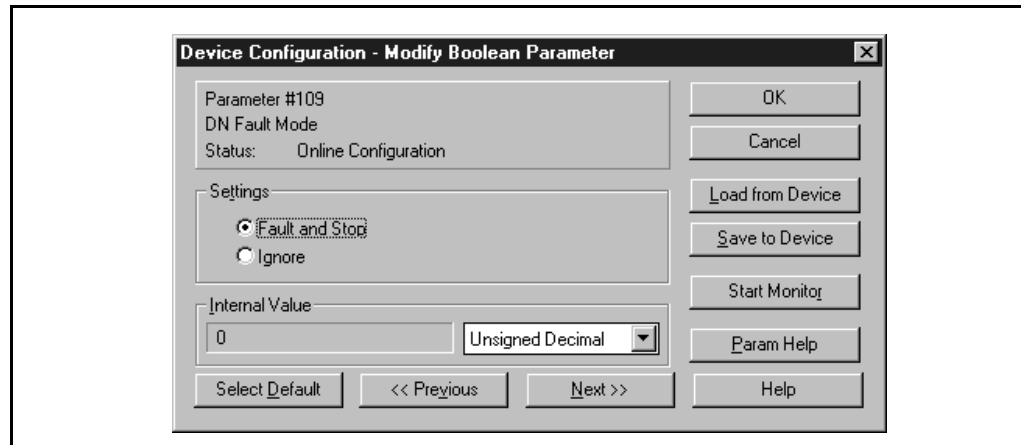

Figure 3.14 – Modifying the Fault Action Parameter

Step 2. Select the appropriate setting for your application, and then click **Save to Device**.

| Setting | Description |
|----------------|--|
| Fault and Stop | The VSM500 unit is faulted and stopped. |
| Ignore | The disruption is ignored and the VSM500 unit continues to run. If this setting is used, another method of stopping the drive must be available (via the Function Loss terminal or the Stop terminal). |

Step 3. Click **OK** to close the dialog box.

3.11 Setting the Idle Action

The idle action determines how the VSM500 unit and DeviceNet option board respond when the scanner is placed in idle/program mode. By default, the VSM500 unit is sent zero data. You can change these settings if your application requires it.



ATTENTION: Parameter 110 [DNET IDLE MODE] determines the action of the option and connected VSM500 unit if the scanner is placed in idle mode. By default, this parameter sends zero data to the unit. You can set this parameter so that the unit continues to run. Precautions should be taken to ensure that the setting of this parameter does not create a hazard. Failure to observe these precautions could result in bodily injury or damage to equipment.

Step 1. In the Device Configuration - Enhanced Mode dialog box (see figure 3.8), double-click **parameter 110 [DNET IDLE MODE]**. The Device Configuration - Modify Boolean Parameter dialog box appears.

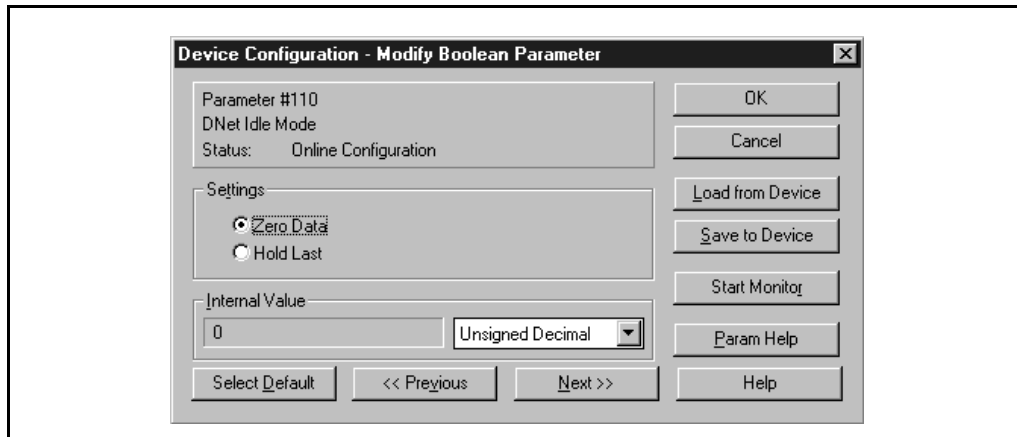

Figure 3.15 – Modifying the Idle Action Parameter

Step 2. Select the appropriate setting for your application, and then click **Save to Device**.

| Setting | Description |
|-----------------|---|
| Zero Data | The VSM500 unit is sent 0 for output data when the scanner is in idle mode. This stops the VSM500 unit. |
| Hold Last State | The VSM500 unit continues in its present state after the scanner is in idle mode. This may not stop the VSM500 unit. If this setting is used, another method of stopping the drive must be available (via the Function Loss terminal or the Stop terminal). |

Step 3. Click **OK** to close the dialog box.

3.12 Setting the COS (Change of State) Mask

If you are using COS data exchange, you need to set a mask. The mask determines which bits in the network status can trigger an I/O message.

Step 1. In the Device Configuration - Enhanced Mode dialog box (see figure 3.8), double-click **parameter 112 [CHANGE OF STATE]**. The Device Configuration - Modify Bit Parameter dialog box appears.

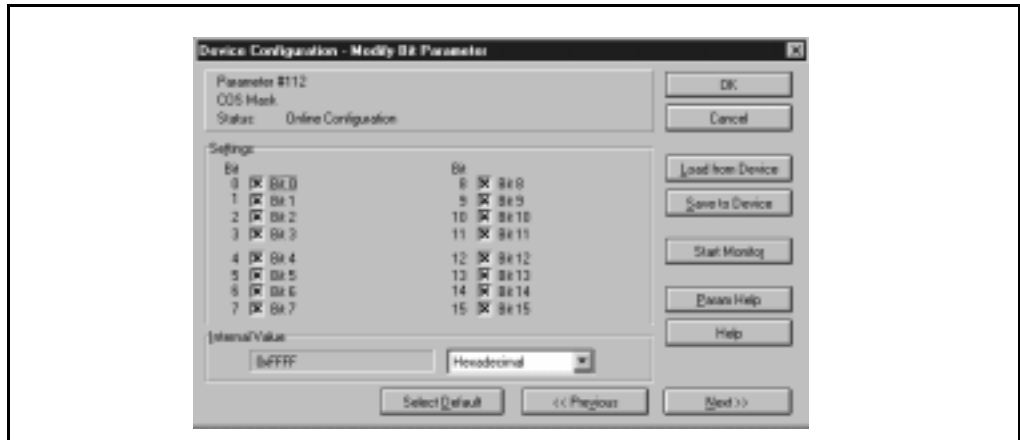

Figure 3.16 – Modifying the Change of State Mask

Step 2. Select the bits (an “X” appears) that you want reviewed for changes, and then click **Save to Device**.

Step 3. Click **OK** to close the dialog box.

3.13 Resetting the DeviceNet Option Board



ATTENTION: Resetting the option may fault the VSM500 unit, resulting in equipment damage, injury, or death. Ensure that the VSM500 unit can stop safely before resetting it. Failure to observe this precaution could result in severe bodily injury or loss of life.

For changes to some parameters in the option board to take effect, you must reset the option board. **Parameter 113 [RESET]** can be used to reset the option board, restore the option board parameters to their factory default settings, or restore the drive parameters to their factory default settings. To reset the option:

Step 1. In the Device Configuration - Enhanced Mode dialog box (see figure 3.8), double-click **parameter 113 [RESET]**. The Device Configuration - Modify Enumerated Parameter dialog box appears.

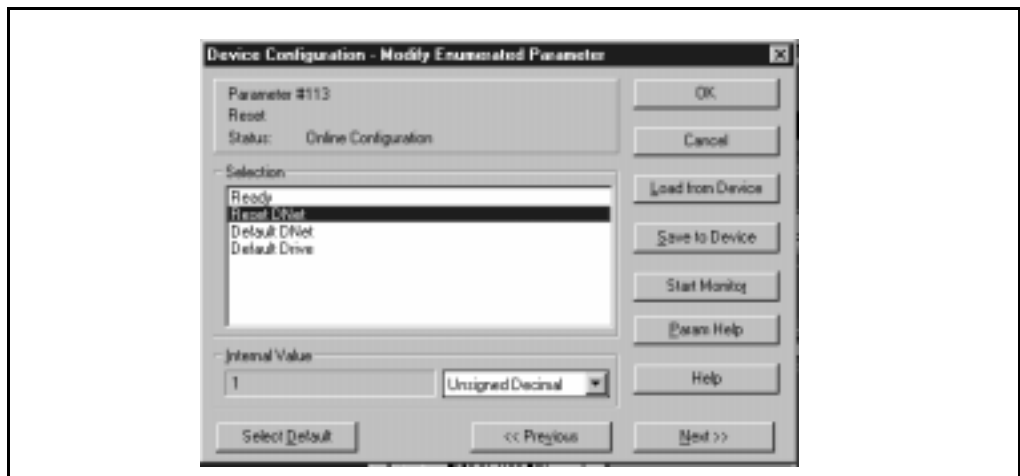

Figure 3.17 – Modifying the Reset Parameter

- Step 2. Select **Reset DNet**, and then click **Save to Device**. The DeviceNet option board will be reset. To view the new settings in DeviceNet Manager, you may need to scan the network.
- Step 3. Click **OK** to close the dialog box.

CHAPTER 4

Configuring a Scanner

This chapter provides the procedures that are needed to configure the simple network that is illustrated in figure 4.1. It provides information and instructions for configuring an SLC 500 controller with a 1747-SDN scanner to communicate with a VSM500 Integrated drive/motor using a DeviceNet option board.

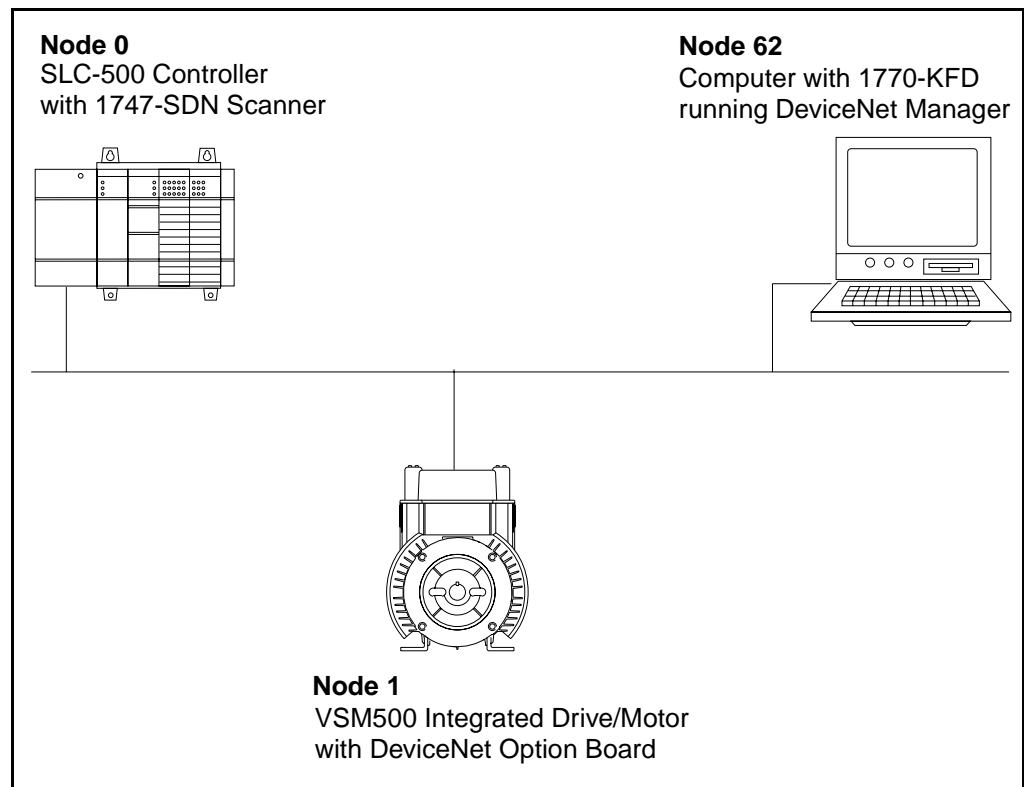

Figure 4.1 – Example DeviceNet Network

4.1 Setting Up the Scan List

For the scanner to communicate with a VSM500 unit, the scanner must be configured and the VSM500 unit's node number must be added to its scan list.

- Step 1. Go online with DeviceNet Manager. Refer to section 3.2
- Step 2. Select **Who > Network Who**. The Network Who window appears, and DeviceNet Manager scans the network for devices. You can wait for DeviceNet Manager to scan the entire network, or click Stop after it displays your VSM500 unit and scanner.

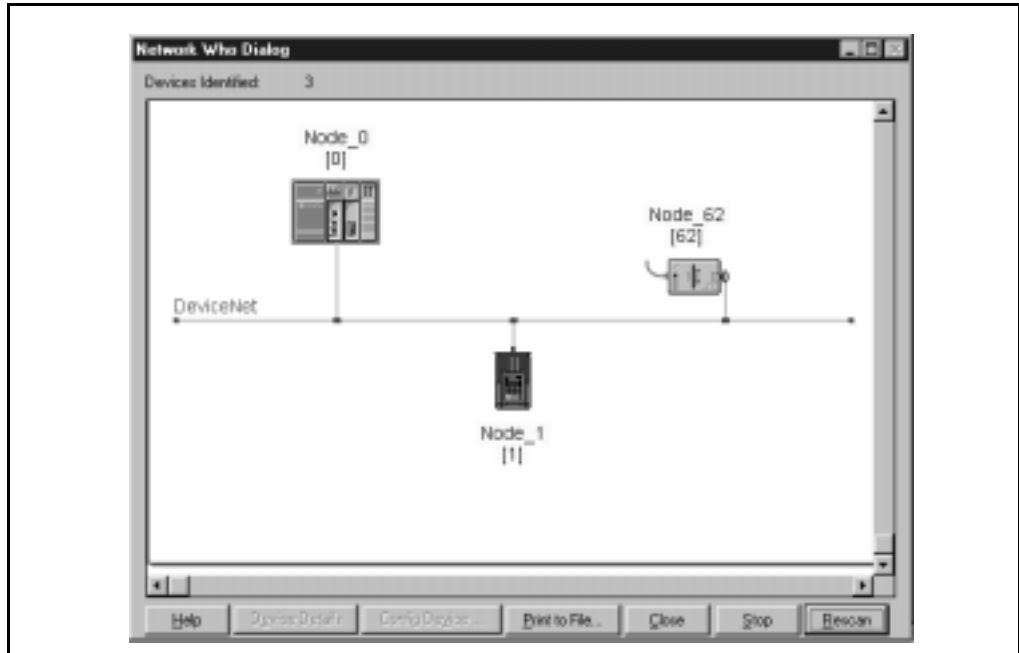

Figure 4.2 – Network Who Window

- Step 3. Double-click the scanner icon to display the 1747-SDN Module Configuration dialog box.

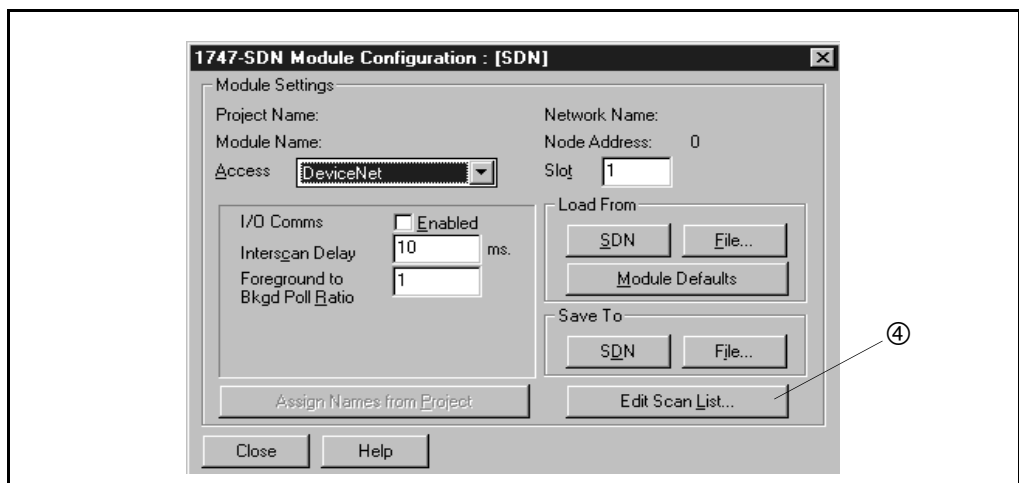

Figure 4.3 – 1747-SDN Module Configuration Dialog Box

- Step 4. Click **Edit Scan List**. The 1747-SDN Scan List Editor dialog box appears.

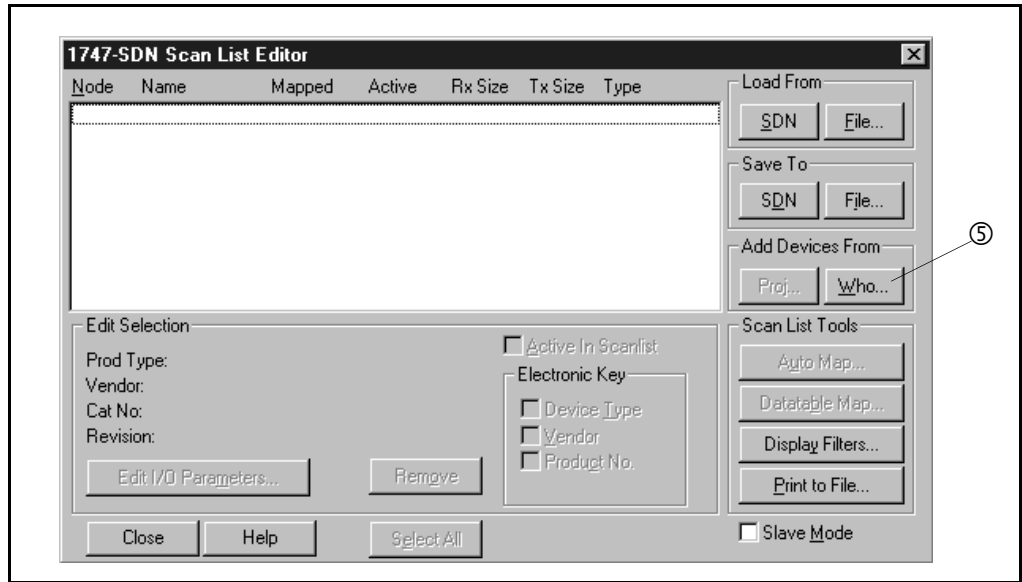

Figure 4.4 – 1747-SDN Scan List Editor Dialog Box

Step 5. Under Add Devices From, click **Who**. The Add Devices to Scan List dialog box appears.

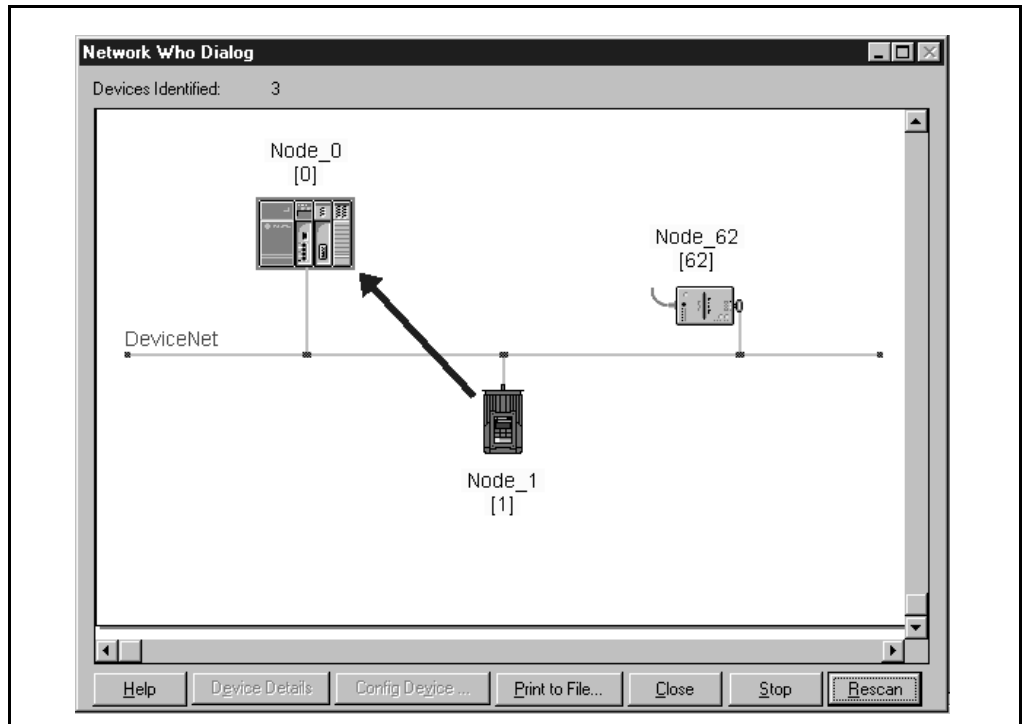

Figure 4.5 – Add Devices to Scan List Dialog Box

Step 6. Drag and drop the icon for the VSM500 unit onto the scanner icon. The VSM500 icon will be outlined with a square.

Step 7. Click **OK**. The Scan List Editor dialog box reappears, and the VSM500 node appears in the scan list.

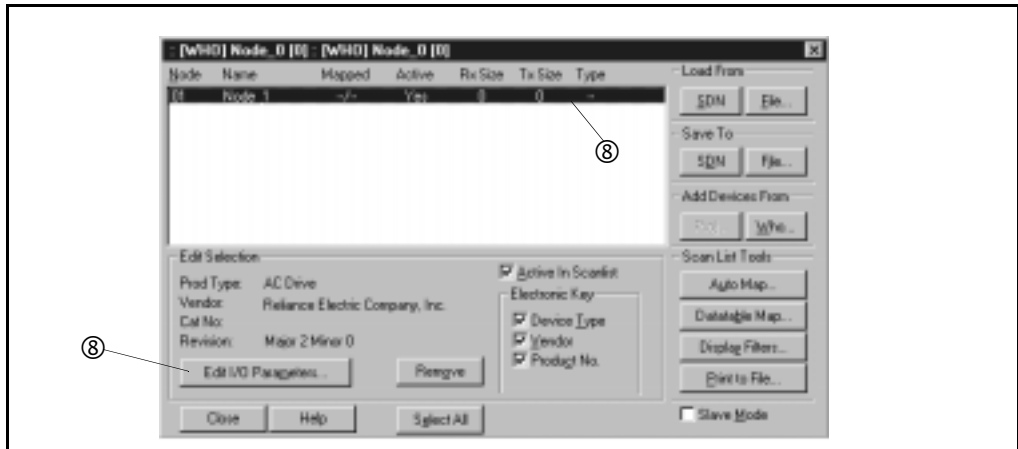

Figure 4.6 – Scan List Editor Dialog Box

Step 8. Click the new node to highlight it, and then click **Edit I/O Parameters**. The Edit Device I/O Parameters dialog box appears.



Figure 4.7 – Edit Device I/O Parameters Dialog Box

Step 9. Set up the scanner for Polled I/O, Change of State, or Cyclic data exchange. Refer to your settings for **parameter 108 [INPUT ASSEMBLY]** and **parameter 107 [OUTPUT ASSEMBLY]** to determine your I/O sizes:

| 108 - [INPUT ASSEMBLY] | Rx Size | 107 - [OUTPUT ASSEMBLY] | Tx Size |
|-------------------------------|---------|---------------------------------|---------|
| 0 = No Data | 0 | 0 = No Data | 0 |
| 50 = Basic Overload | 1 | 1 = Basic Contactor | 1 |
| 51 = Extended Overload | 1 | 2 = Two Command Contactor | 1 |
| 52 = Basic Motor Control | 1 | 3 = Basic Overload | 1 |
| 53 = Extended Motor Control | 1 | 4 = Basic Motor Control | 1 |
| 54 = Extended Motor Control 2 | 1 | 5 = 2 Command Motor | 1 |
| 70 = Basic Speed Control | 4 | 20 = Basic Speed Control | 4 |
| 71 = Extended Speed Control | 4 | 21 = Extended Speed Control | 4 |
| | | 100 = Speed Control in Hz | 4 |
| | | 106 = Preset Control with Speed | 4 |

Figure 4.7 shows an example that uses polled I/O. The Enable box was selected, 4 was typed in the Rx box because Input Assembly 71 is being used, and 4 was typed in the Tx box because Output Assembly 21 is being used. Finally, Every Scan was selected in the Poll Rate box.

Step 10. Click **OK**. A DeviceNet Manager message appears.

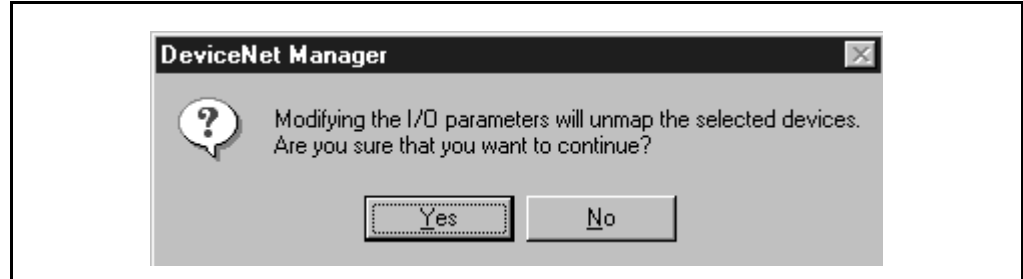

Figure 4.8 – DeviceNet Manager Message

Step 11. Click **Yes**. The Scan List Editor dialog box reappears. It should have the size of I/O in the RX Size and Tx Size columns.



Figure 4.9 – 1747-SDN Scan List Editor Dialog Box

The scan list is now set up, and the VSM500 is in the scan list. You are now ready to map the VSM500 unit's data in the scanner.

4.2 Mapping the VSM500 Unit's Data in the Scanner

Data from I/O messages may be mapped to the SLC's discrete I/O area or to an I/O area located in the M0 and M1 files. This mapping determines where a ladder logic program can find data that is transmitted over the network. In our example, we will use the discrete area.

You must map both the input I/O and the Output I/O.

4.2.1 Mapping the Input I/O

Step 1. In the Scan List Editor dialog box (see figure 4.9), click **Datatable Map** under Scan List Tools. The Datatable Map dialog box appears.

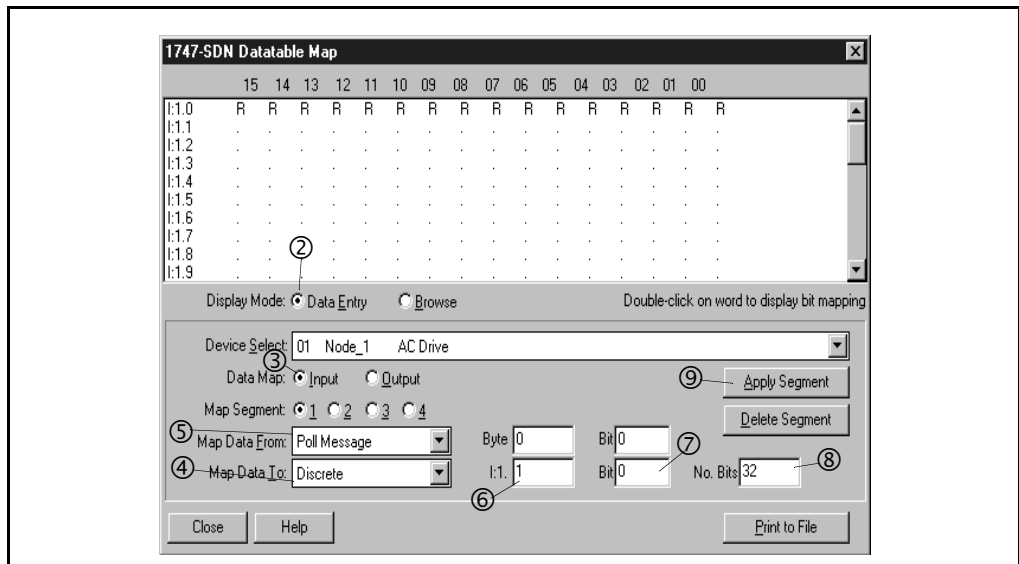

Figure 4.10 – Datatable Map Dialog Box

Step 2. Next to Display Mode, select **Data Entry**. A dot appears in the circle.

Step 3. Next to Data Map, select **Input** to map the input data.

Step 4. In the Map Data To box, select where the data is to be placed.

Step 5. In the Map Data From box, select from where the data is received.

Step 6. In the I:1. box, type the word where the data will be mapped. In the example, it is mapped to word 1 (second word).

Step 7. In the Bit box, type the bit at which the data starts.

Step 8. In the No. Bits box, type the number of bits that your data requires.

Step 9. Click **Apply Segment**. A new datatable map appears in the dialog box.

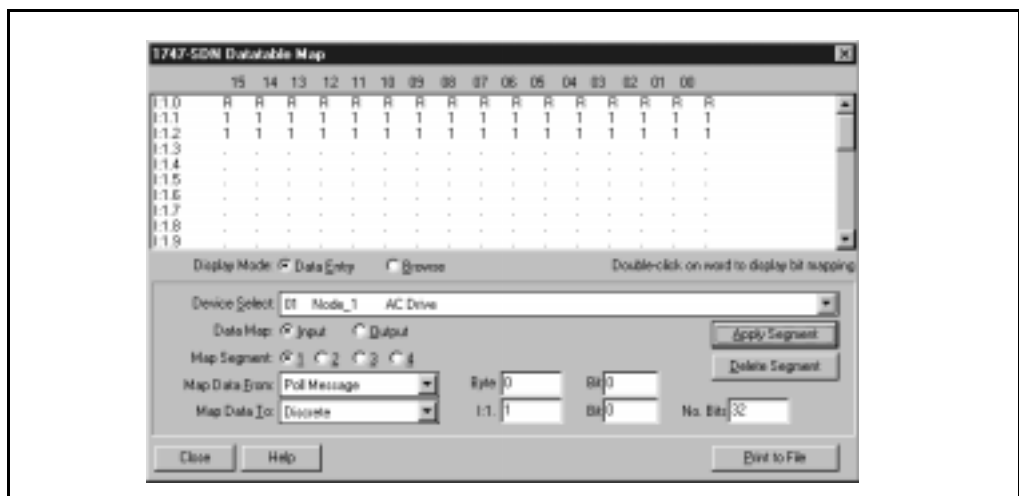

Figure 4.11 – Input Datatable Map

4.2.2 Mapping the Output I/O

Step 1. In the Datable Map dialog box (see figure 4.11), select **Output** to map the Output data. A dot appears in the circle.

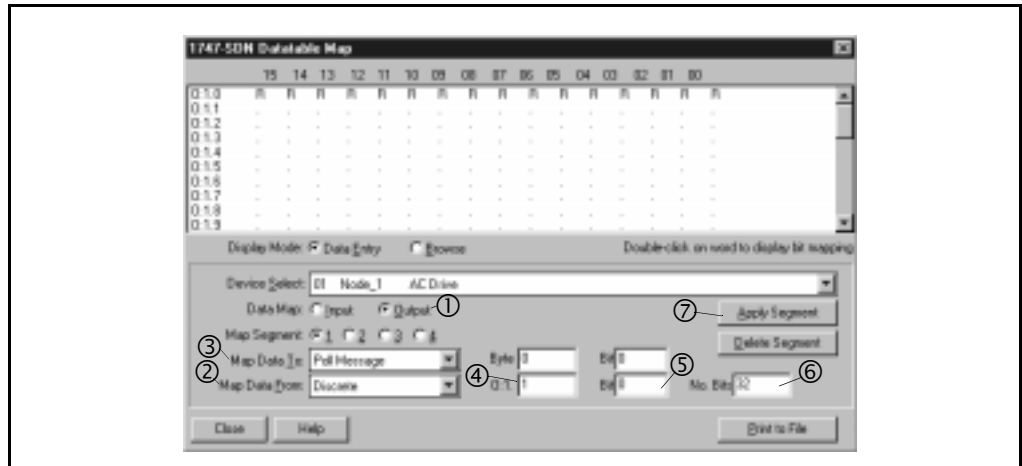

Figure 4.12 – Output Datable Map

Step 2. In the Map Data From box, select from where the data is transmitted.

Step 3. In the Map Data To box, select the destination of the data.

Step 4. In the O:1 box, type the word where the data will be found.

Step 5. In the Bit box, type the bit at which the data starts.

Step 6. In the No. Bits box, type the number of bits that your data requires.

Step 7. Click **Apply Segment**. A new datatable map appears in the dialog box.

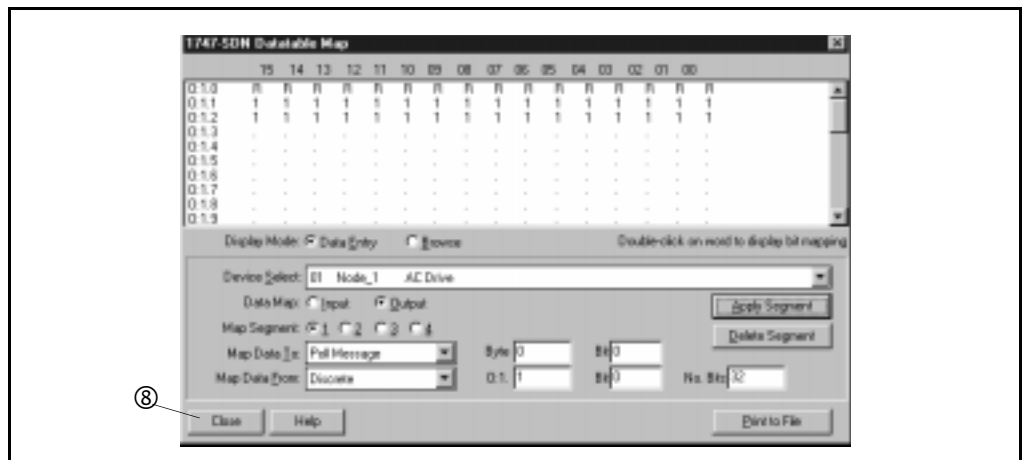

Figure 4.13 – Output Datable Map

Step 8. Click **Close**. The Scan List Editor dialog box reappears.

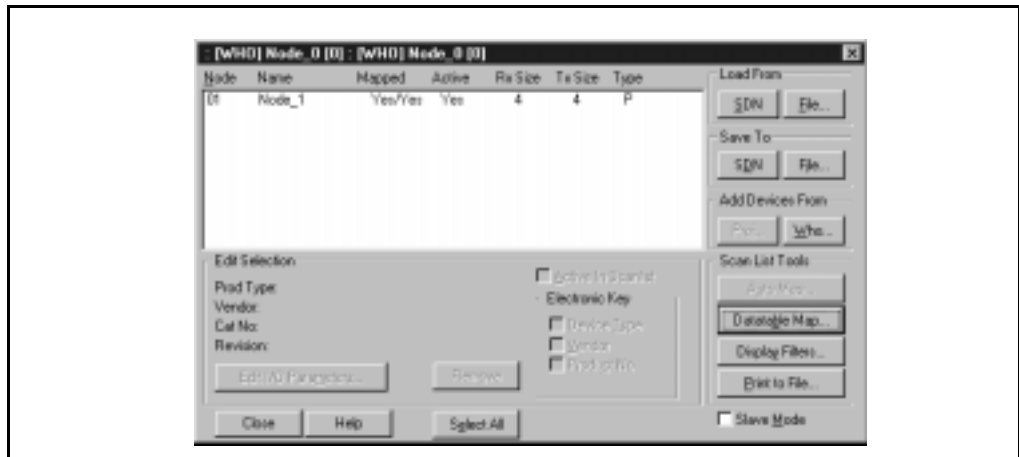

Figure 4.14 – Scan List Editor Dialog Box

The data transmitted between the VSM500 unit and SLC scanner is now mapped to the scanner.

4.3 Saving the Configuration

After creating a configuration, you should download it to the scanner.

Step 1. In the Scan List Editor dialog box, click **SDN** under Save To. The Scan List Editor - Download dialog box appears.

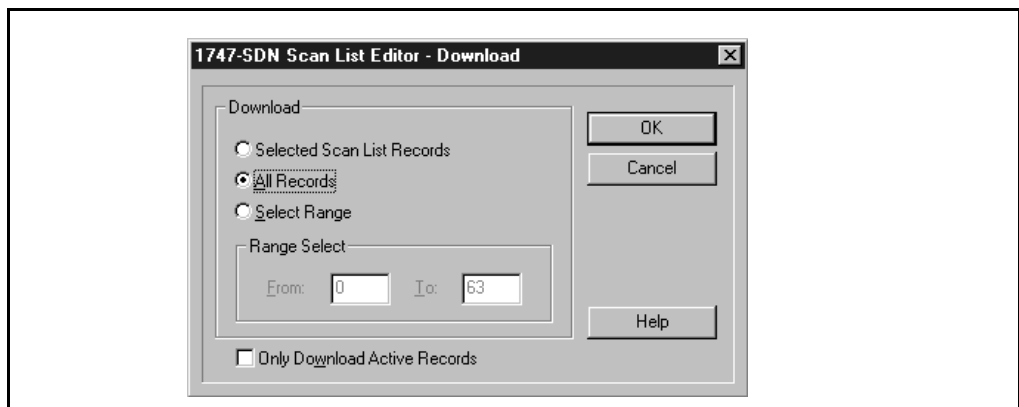

Figure 4.15 – Scan List Editor - Download Dialog Box

Step 2. Select **All Records**, and then click **OK**. A DeviceNet Manager message will appear and inform you that the scanner will not be available for a period of time.

Step 3. Click **OK** to download the new configuration to the SLC. The Scan List Editor dialog box (see figure 4.14) reappears.

Step 4. Click **Close** to close the Scan List Editor dialog box. A message box appears and prompts you to save the configuration to a file. If desired, save to a file. The 1747-SDN dialog box (see figure 4.3) appears.

Step 5. Click **Close** to close the 1747-SDN dialog box. A message box appears and prompts you to save the configuration to a file. If desired, save to a file. The Network Who window (see figure 4.2) appears.

Using I/O Messaging

This chapter provides information about using control I/O. It includes information on understanding I/O messaging and assemblies, an example of I/O messaging, and an example SLC ladder logic program.

Important: To use control I/O, you must have already configured the VSM500 unit and DeviceNet option (refer to chapter 3) and scanner (refer to chapter 4).

5.1 Understanding I/O Messaging and Assemblies

On DeviceNet, I/O messaging, sometimes called implicit messaging, is used to transfer the I/O data, which controls the VSM500 unit and its speed.

The control I/O messages that are transmitted between the scanner and VSM500 unit depend on the output assembly and input assembly that you select. You can choose between various input and output assemblies, thereby choosing the data format of the control I/O messages. The assemblies that are supported are numbered and are part of a DeviceNet defined "Motor Control Hierarchy." This feature lets you use a VSM500 unit to replace motor starters or contactors on a network without the need to reprogram the scanner.

You select the output assembly using **parameter 107 [OUTPUT ASSEMBLY]** and the input assembly using **parameter 108 [INPUT ASSEMBLY]**. These parameters are described in the parameter list in Appendix B (section B.3). Data formats for assemblies are in Appendix C (section C.5).

5.2 Example of I/O Messaging

For example, Output Assembly 21 uses the following data format:

| Byte | Bit 7 | Bit 6 | Bit 5 | Bit 4 | Bit 3 | Bit 2 | Bit 1 | Bit 0 |
|------|---------------------------------|--------|-------------|-------|-------|-------------|--------|--------|
| 0 | | NetRef | Net Control | | | Fault Reset | RunRev | RunFwd |
| 1 | Not Used | | | | | | | |
| 2 | Speed Reference RPM (Low Byte) | | | | | | | |
| 3 | Speed Reference RPM (High Byte) | | | | | | | |

Input Assembly 71 uses the following data format:

| Byte | Bit 7 | Bit 6 | Bit 5 | Bit 4 | Bit 3 | Bit 2 | Bit 1 | Bit 0 |
|------|------------------------------|-------------|--------------|-------|-----------------|-----------------|-------|---------|
| 0 | At Reference | RefFrom Net | CtrlFrom Net | Ready | Running Reverse | Running Forward | | Faulted |
| 1 | Not Used | | | | | | | |
| 2 | Speed Actual RPM (Low Byte) | | | | | | | |
| 3 | Speed Actual RPM (High Byte) | | | | | | | |

Figure 5.1 illustrates how data in Output Assembly 21 and Input Assembly 71 will be transmitted between a VSM500 unit and an SLC processor. Notice that the terms *input* and *output* are defined from the scanner's point of view. Also notice that explicit messaging can be transmitted as well.

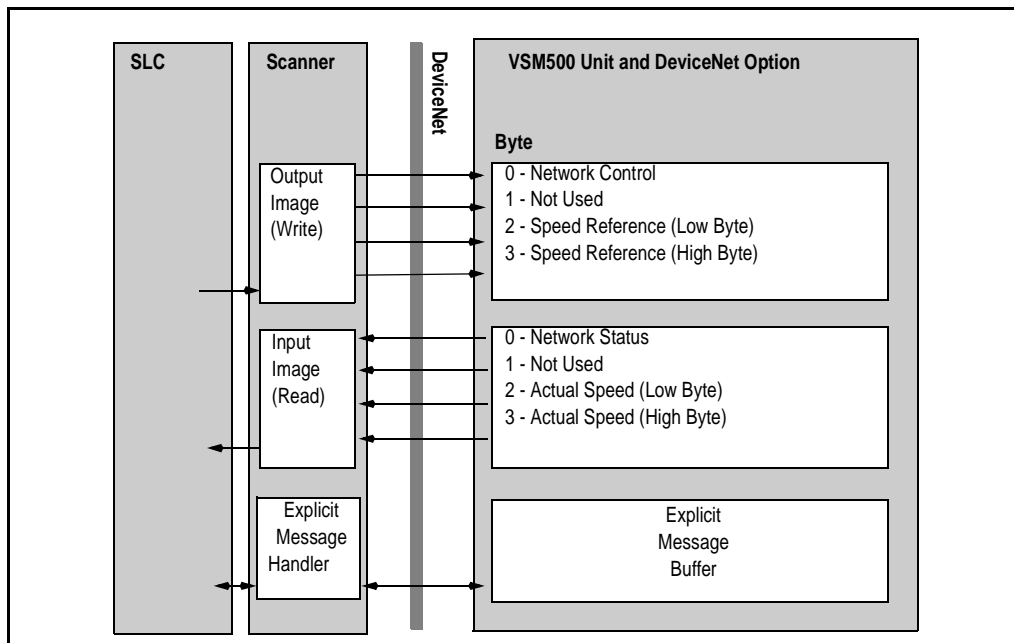

Figure 5.1 – Example I/O Image

5.3 Example SLC Ladder Logic Program

The example program runs the VSM500 unit in the forward and reverse direction. It also provides a speed reference. Note that the scanner must be in Slot 1 of the SLC 500 rack for this example.

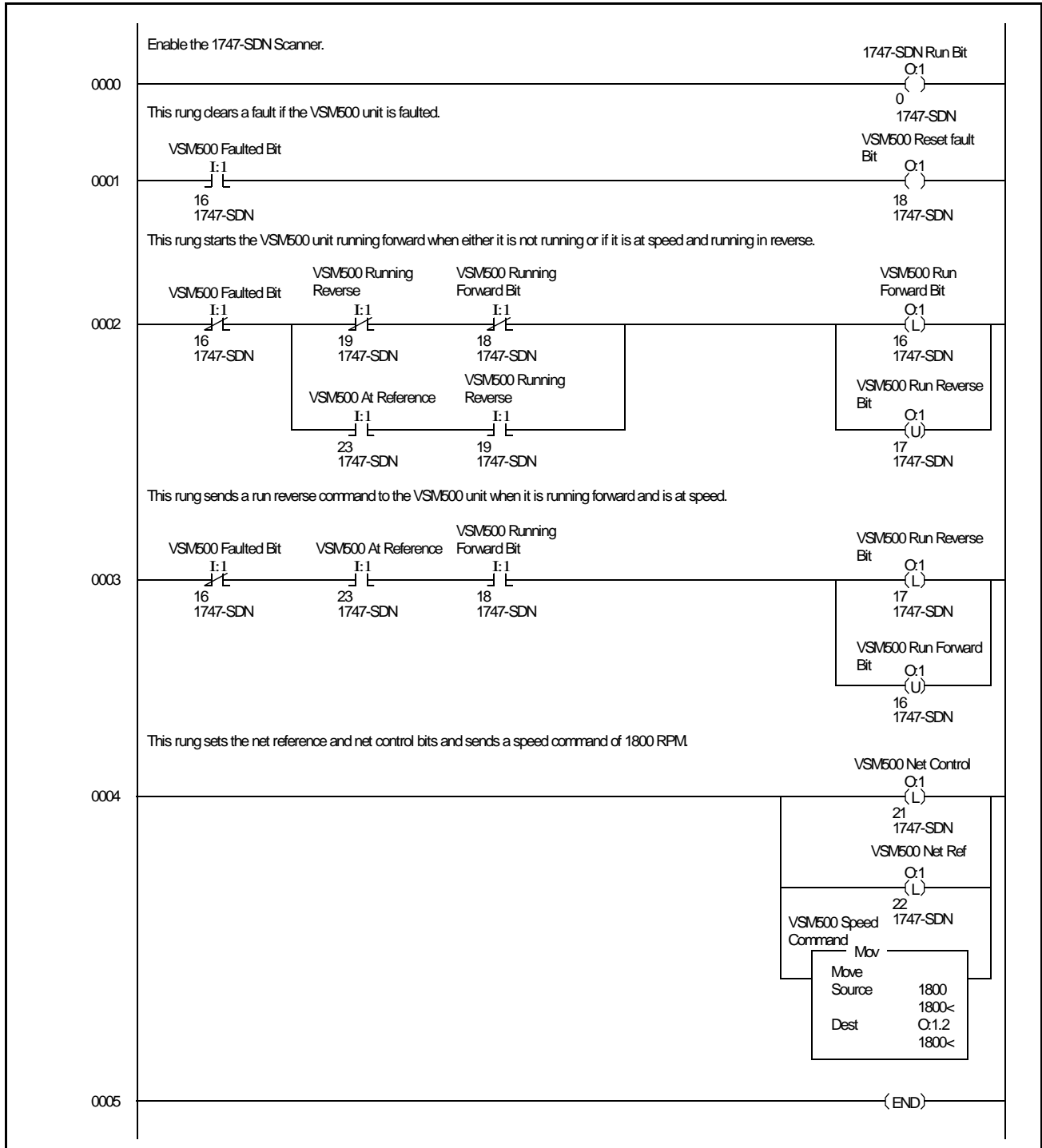

Figure 5.2 – Example SLC Ladder Logic Program

Using Explicit Messaging

This chapter provides information about using explicit messaging. It includes information on about using explicit messaging, how to format explicit messages, and an example of an SLC ladder logic program.

Important: In order to use explicit messaging, you must have already configured the VSM500 unit and DeviceNet option (see chapter 3) and the scanner (see chapter 4).

6.1 About Explicit Messaging

Explicit messaging is a way of configuring and monitoring a slave device's parameters on the DeviceNet network. This form of messaging is performed by copying data to and from the SLC controller M0 and M1 file. Explicit messaging can only be done by the SLC controller to slave devices that are mapped in the scanner module's scan list.

6.2 Using Explicit Messaging

With an SLC 500, there are five steps to the explicit messaging process.

- Step 1. Format an M0 file transfer in the processor to send an explicit message request to the scanner module (download).
- Step 2. The scanner module transmits the explicit message request to the slave device over the DeviceNet network.
- Step 3. The slave device transmits the explicit message response back to the scanner and is queued into a file transfer buffer.
- Step 4. The processor uses an M1 file transfer to retrieve the explicit message response from the scanner's buffer (upload).
- Step 5. Format an M0 file transfer with a Delete Response Command, and use the current transaction ID read in step 4. The transaction IDs are deleted and can be reused.

Important: There must be a request message and an response message whether you are reading or writing a parameter.

6.3 Formatting Explicit Messages

There are ten 32-word transaction blocks within the scanner module reserved for explicit message program control. These transaction blocks accommodate both downloading explicit message requests and uploading explicit message responses. The scanner module can accommodate one request or response for each transaction block. Each transaction block must be formatted as shown in figure 6.1.

| Request | | Response | |
|--------------|---------|-----------------------|--------|
| 15 | 0 | 15 | 0 |
| TXID | Command | TXID | Status |
| Port | Size | Port | Size |
| Service | MAC ID | Service | MAC ID |
| Class | | Service Response Data | |
| Instance | | | |
| Attribute | | | |
| Service Data | | | |

Figure 6.1 – Explicit Message Format

| Data Field | Description | | | | | | | | | | | | | | | | | | |
|---|--|--------------------------------------|--|--|--|---|--|-----------------------------|---|--------------------|--------------------|---|------------------------------|-------------------------------|-----------------------|------------|---------------------|---------------------------|--|
| TXID | The transaction ID is a 1-byte integer in word 31 with a range of 1 to 255. It is assigned in the ladder logic program when the processor creates and downloads a request to the scanner. The scanner uses it to track the transaction to completion. It returns this value with the response that matches the request downloaded by the processor. | | | | | | | | | | | | | | | | | | |
| Command | One of the following command codes instructs the scanner how to administer the request during each download: <table border="1"> <tr> <td>0 = Ignore transaction block (empty)</td> <td>3 = Reset all client/server transactions</td> </tr> <tr> <td>1 = Execute this transaction block</td> <td>4 = Delete this transaction block</td> </tr> <tr> <td>2 = Get status of transaction TXID</td> <td>5 – 255 = Reserved</td> </tr> </table> | 0 = Ignore transaction block (empty) | 3 = Reset all client/server transactions | 1 = Execute this transaction block | 4 = Delete this transaction block | 2 = Get status of transaction TXID | 5 – 255 = Reserved | | | | | | | | | | | | |
| 0 = Ignore transaction block (empty) | 3 = Reset all client/server transactions | | | | | | | | | | | | | | | | | | |
| 1 = Execute this transaction block | 4 = Delete this transaction block | | | | | | | | | | | | | | | | | | |
| 2 = Get status of transaction TXID | 5 – 255 = Reserved | | | | | | | | | | | | | | | | | | |
| Status | One of the following status codes is provided during each upload: <table border="1"> <tr> <td>0 = Ignore transaction block (empty)</td> <td>9 = Scanner out of buffers.</td> </tr> <tr> <td>1 = Transaction completed successfully</td> <td>10 = Other client/server transaction in progress</td> </tr> <tr> <td>2 = Transaction in progress (not ready)</td> <td>11 = Could not connect to slave device</td> </tr> <tr> <td>3 = Slave not in scan list.</td> <td>12 = Response data too large for block.</td> </tr> <tr> <td>4 = Slave offline.</td> <td>13 = Invalid port.</td> </tr> <tr> <td>5 = DeviceNet port disabled or offline.</td> <td>14 = Invalid size specified.</td> </tr> <tr> <td>6 = Transaction TXID unknown.</td> <td>15 = Connection busy.</td> </tr> <tr> <td>7 = Unused</td> <td>16 – 255 = Reserved</td> </tr> <tr> <td>8 = Invalid command code.</td> <td></td> </tr> </table> | 0 = Ignore transaction block (empty) | 9 = Scanner out of buffers. | 1 = Transaction completed successfully | 10 = Other client/server transaction in progress | 2 = Transaction in progress (not ready) | 11 = Could not connect to slave device | 3 = Slave not in scan list. | 12 = Response data too large for block. | 4 = Slave offline. | 13 = Invalid port. | 5 = DeviceNet port disabled or offline. | 14 = Invalid size specified. | 6 = Transaction TXID unknown. | 15 = Connection busy. | 7 = Unused | 16 – 255 = Reserved | 8 = Invalid command code. | |
| 0 = Ignore transaction block (empty) | 9 = Scanner out of buffers. | | | | | | | | | | | | | | | | | | |
| 1 = Transaction completed successfully | 10 = Other client/server transaction in progress | | | | | | | | | | | | | | | | | | |
| 2 = Transaction in progress (not ready) | 11 = Could not connect to slave device | | | | | | | | | | | | | | | | | | |
| 3 = Slave not in scan list. | 12 = Response data too large for block. | | | | | | | | | | | | | | | | | | |
| 4 = Slave offline. | 13 = Invalid port. | | | | | | | | | | | | | | | | | | |
| 5 = DeviceNet port disabled or offline. | 14 = Invalid size specified. | | | | | | | | | | | | | | | | | | |
| 6 = Transaction TXID unknown. | 15 = Connection busy. | | | | | | | | | | | | | | | | | | |
| 7 = Unused | 16 – 255 = Reserved | | | | | | | | | | | | | | | | | | |
| 8 = Invalid command code. | | | | | | | | | | | | | | | | | | | |
| Port | The port used by the message is always zero (Channel A) on a 1747-SDN scanner. | | | | | | | | | | | | | | | | | | |
| Size | The size of the service data is in bytes. The maximum size is 58 bytes (29 words). | | | | | | | | | | | | | | | | | | |
| Service | The service attribute contains the DeviceNet service request and response codes that match the corresponding TXID. | | | | | | | | | | | | | | | | | | |
| MAC ID | The node address of the slave device to which the transaction is sent. This value has a range of 0 to 63. The slave device must be listed in the scanner's scan list and be online for the explicit message transaction to be completed. | | | | | | | | | | | | | | | | | | |

6.4 Example SLC Ladder Logic Program

The example ladder logic program (see figure 6.2) can be used to do explicit messaging from an SLC. This ladder program will allow the SLC 500 to use explicit messaging to read and write parameters to a VSM500 Integrated drive/motor.

To run the example program:

Step 1. Enter data into the program.

The request information will be placed in the N10 file. The *first* word in N10 will be the TXID and command information, which both receive a value of one. The *second* word will be the port and size information. The port value will be zero when using an SLC, and the size will be the number of bytes for the class, instance, attribute, and service data. The *third* word will contain the service and Node Address. The service will be either a set (write) or a get (read) attribute. The value for a set is 0x10, and the value for a get is 0x0E. The node address will be the node address assigned to the slave device (VSM500 Integrated drive/motor). Finally, the class, instance, and attribute for the parameter have to be entered. These values can be found in Appendix B and Appendix C.

Step 2. Run the program.

After entering the request into the N10 file, the program needs to be triggered to run. Triggering the program is done by changing the address N7:0/0 from a zero to a one. The program will change the address back to zero when the explicit message is complete.

Step 3. Receive Data from the program.

After the program has been run, the results can be seen in the N11 address. The SLC program should read/copy the data before performing another explicit message request. It is important to note that the command byte in node N10:0/0 is changed when the program executes and must be changed back to a one before the program can be run again.

Data Format for a Read and Write Parameter

The data in this example is for a VSM500 unit with a DeviceNet option at node address 1.

Request Data for Read of Parameter 32 - [ACCEL TIME]

N10 address

| address | 0 | 1 | 2 | 3 | 4 | 5 | 6 | 7 | 8 | 9 |
|---------|------|------|------|------|------|------|------|------|------|------|
| N10:0 | 0101 | 0006 | 0E01 | 000F | 0020 | 0001 | 0000 | 0000 | 0000 | 0000 |
| N10:10 | 0000 | 0000 | 0000 | 0000 | 0000 | 0000 | 0000 | 0000 | 0000 | 0000 |
| N10:20 | 0000 | 0000 | 0000 | 0000 | 0000 | 0000 | 0000 | 0000 | 0000 | 0000 |
| N10:30 | 0000 | 0000 | 0000 | 0000 | 0000 | 0000 | 0000 | 0000 | 0000 | 0000 |

Response Data for Read of Parameter 32 - [ACCEL TIME]

N11 address

| address | 0 | 1 | 2 | 3 | 4 | 5 | 6 | 7 | 8 | 9 |
|---------|------|------|------|------|------|------|------|------|------|------|
| N11:0 | 0101 | 0002 | 8E01 | 0032 | 0000 | 0000 | 0000 | 0000 | 0000 | 0000 |
| N11:10 | 0000 | 0000 | 0000 | 0000 | 0000 | 0000 | 0000 | 0000 | 0000 | 0000 |
| N11:20 | 0000 | 0000 | 0000 | 0000 | 0000 | 0000 | 0000 | 0000 | 0000 | 0000 |
| N11:30 | 0000 | 0000 | 0000 | 0000 | 0000 | 0000 | 0000 | 0000 | 0000 | 0000 |

Request Data for Write to Parameter 32 - [ACCEL TIME]

N10 address

| address | 0 | 1 | 2 | 3 | 4 | 5 | 6 | 7 | 8 | 9 |
|---------|------|------|------|------|------|------|------|------|------|------|
| N10:0 | 0101 | 0008 | 1001 | 000F | 0020 | 0001 | 0064 | 0000 | 0000 | 0000 |
| N10:10 | 0000 | 0000 | 0000 | 0000 | 0000 | 0000 | 0000 | 0000 | 0000 | 0000 |
| N10:20 | 0000 | 0000 | 0000 | 0000 | 0000 | 0000 | 0000 | 0000 | 0000 | 0000 |
| N10:30 | 0000 | 0000 | 0000 | 0000 | 0000 | 0000 | 0000 | 0000 | 0000 | 0000 |

Response Data for Write to Parameter 32 - [ACCEL TIME]

N11 address

| address | 0 | 1 | 2 | 3 | 4 | 5 | 6 | 7 | 8 | 9 |
|---------|------|------|------|------|------|------|------|------|------|------|
| N11:0 | 0101 | 0000 | 9001 | 0000 | 0000 | 0000 | 0000 | 0000 | 0000 | 0000 |
| N11:10 | 0000 | 0000 | 0000 | 0000 | 0000 | 0000 | 0000 | 0000 | 0000 | 0000 |
| N11:20 | 0000 | 0000 | 0000 | 0000 | 0000 | 0000 | 0000 | 0000 | 0000 | 0000 |
| N11:30 | 0000 | 0000 | 0000 | 0000 | 0000 | 0000 | 0000 | 0000 | 0000 | 0000 |

Example Ladder Logic Program

Note that the scanner must be in Slot 1 of the SLC 500 rack for this example.

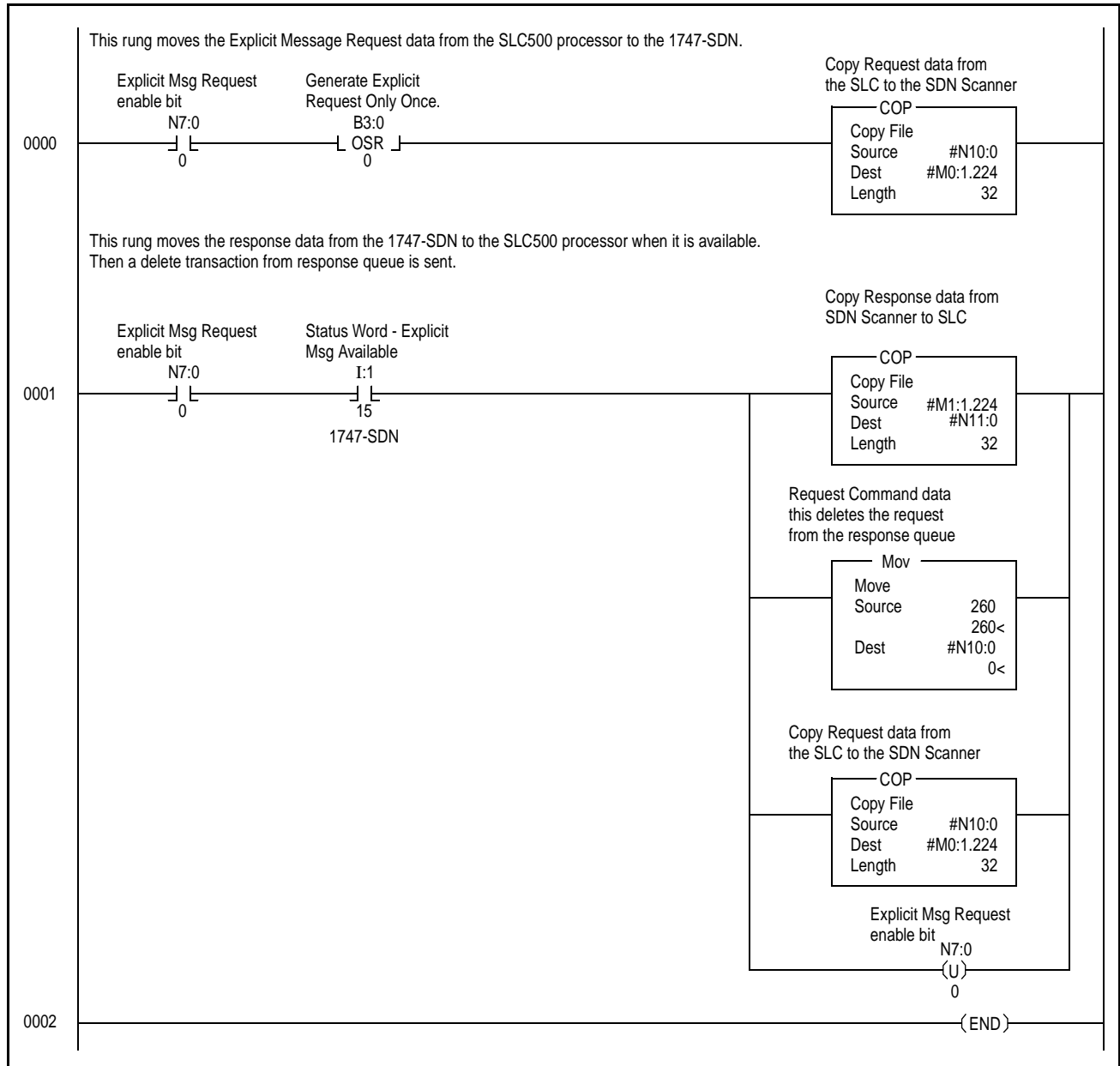

Figure 6.2 – Example SLC Ladder Logic Program

For more information on explicit messaging, refer to the documentation for your scanner.

This chapter contains information for diagnosing and correcting potential problems.

7.1 Locating the COMM Status Indicator

The VSM500 Integrated drive/motor has a COMM status indicator that you can use to determine the status of the VSM500 unit and DeviceNet communications.

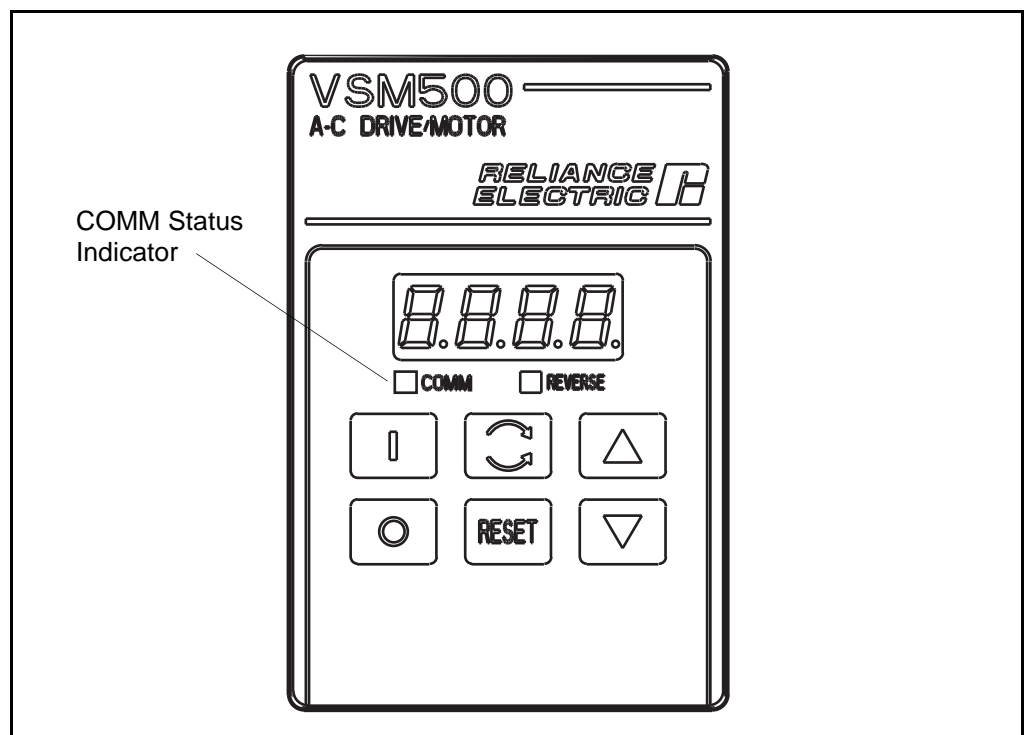

Figure 7.1 – VSM500 Integrated Drive/Motor COMM Status Indicator

7.2 Understanding the COMM Status Indicator

The COMM status indicator provides status information on the DeviceNet option board.

Important: When power is first applied to the DeviceNet option board, the COMM status indicator flashes green for 1/4 second, red for 1/4 second, and then turns off while the communication module finishes its initialization.

| Color | State | What It Means: | What To Do: |
|-------|----------|---|--|
| None | | The option board is not receiving power from the network. | Check DeviceNet power and cable connections and the power connection on the DeviceNet terminal block. |
| Red | Solid | Diagnostics test failed on power-up/reset. Internal fault exists. | <ul style="list-style-type: none"> • Cycle power to the VSM500 unit and network. • If the fault still exists, return the option board. |
| | | Duplicate DeviceNet node address. Two nodes cannot have the same address. | <ul style="list-style-type: none"> • Reset DIP switches 1 through 6 on the DeviceNet option board using a unique address and then cycle power. • If DIP switches 7 and 8 on the DeviceNet option board are both set to ON, change the value of P103 [NV MAC ID] to a unique address and then cycle power. |
| | | Invalid data rate. | <ul style="list-style-type: none"> • Reset DIP switches 7 and 8 on the DeviceNet option board to a valid data rate and the cycle power. • If DIP switches 7 and 8 on the DeviceNet option board are both set to ON, change the value of P104 [NV BAUD RATE] to a valid data rate and then cycle power. |
| Red | Flashing | I/O connection timed out. | Reset the DeviceNet master device. |
| Green | Solid | Normal operating state and device is allocated to a master. | No action required. |
| Green | Flashing | Device is online but not allocated to a master. | Verify that the DeviceNet master has the correct configuration information for the DeviceNet option board (node address, input assembly, and output assembly). |

7.3 Fault Codes

When there is a fault, you can view the fault code using the value in **parameter 10 [LAST FAULT]**, the value of Class 0x29 (Control Supervisor Object), Instance 1, Attribute 13 (Fault Code), or the display on the keypad.

| Fault Codes ¹ | | | Name | Description | Corrective Action |
|--------------------------|-----------|---------|-----------------------------|--|--|
| Parameter Value | DeviceNet | Display | | | |
| 0 | 0x0000 | | No Fault | Normal operation. | No action required. |
| 1 | 0x5300 | F.FL | Function Loss | Open connection on Function Loss control terminal block inputs (terminals 7 and 11). | <ul style="list-style-type: none"> - Check and restore the Function Loss connection on the terminal block. Refer to <i>VSM500 Integrated Drive/Motor User Manual</i>. - Check the external sensors wired into the Function Loss string. |
| 2 | 0x2220 | F.OC | Over Current | Shaft rotation blocked. Excessive driven load. Input power is not correctly wired to the VSM500 unit. Motor section ground fault. | <ul style="list-style-type: none"> - Check for obstructions to shaft rotation. - Reduce excessive load. - Increase accel/decel time using the rotary switches or parameter 32 [ACCEL TIME] and parameter 33 - [DECEL TIME]. - Verify that input wiring is correctly connected. Refer to the VSM500 Integrated Drive/Motor User Manual. - Check motor section for ground fault. Replace VSM500 unit if a ground fault is detected. |
| 3 | 0x7122 | F.OL | Motor Overload | Excessive current to motor for an extended time due to excessive load or short circuit. | <ul style="list-style-type: none"> - Check for obstruction to shaft rotation. - Reduce the driven load. - Check input wiring is correctly connected. Refer to the VSM500 Integrated Drive/Motor User Manual. - Check for blower obstruction. - Replace blower if required. |
| 4 | 0x3210 | F.HU | Over Voltage | High input line. Deceleration time is too fast or overhauling load. | <ul style="list-style-type: none"> - Check input line to verify that voltage is within operating specification. - Increase deceleration time using the accel/decel rotary switch. Refer to the VSM500 Integrated Drive/Motor User Manual. |
| 5 | 0x3220 | F.LU | Under Voltage while Stopped | Low input line or temporary loss of input line. | Check input line to verify voltage is within operating specifications. |
| 6 | 0x4310 | F.OH | Over Temperature | Operating environment is too hot. Blower is blocked or not operating. Excessive driven load. | <ul style="list-style-type: none"> - Check the application site and verify the ambient temperature is within the operating specification. - Check for blower obstruction. Replace blower if required. - Reduce load or make sure VSM500 unit matches the application requirement. |
| 7 | 0x7510 | F.CL | Communication Loss | Communication between the DeviceNet option board and the drive has failed. | Check cable connection between the regulator board and DeviceNet option board. |
| 8 | 0x6310 | F.dCH | Parameter Checksum | Contents of the EEPROM is corrupted. | Reset parameters to default values and cycle power. |

¹Parameter fault codes are viewed in **parameter 10 [LAST FAULT]**. DeviceNet fault codes are read from Class 0x29, Instance 1, Attribute 13. Display fault codes are viewed on the LED display on the local operator control keypad.

| Fault Codes ¹ | | | Name | Description | Corrective Action |
|--------------------------|-----------|---------|-----------------------------|---|--|
| Parameter Value | DeviceNet | Display | | | |
| 9 | 0x6312 | F.Id | EEPROM Drive ID | Contents of the EEPROM is corrupted. | - Reset parameters to default values and cycle power. - If fault persists, replace VSM500 unit. |
| 10 | 0x7700 | F.dcn | Keypad Disconnect | Keypad cable disconnected while VSM500 unit under power. | Remove power from the VSM500 unit. Check keypad cable connection. Reapply power to the VSM500 unit. |
| 11 | 0x7701 | F.ddP | Keypad Fixed Pattern | Keypad cable connected while VSM500 unit under power. | Remove power from the VSM500 unit. Check the keypad cable connection. Reapply power to the VSM500 unit. |
| 12 | 0x7702 | F.dSF | Keypad Redundant Start | Keypad hardware failure. | Remove power from the VSM500 unit. Check the keypad cable connection. Reapply power to the VSM500 unit. |
| 13 | 0x5301 | F.rSF | TB Redundant Start | Regulator board failure. | Remove power from the VSM500 unit. Check the keypad cable connection. Reapply power to the VSM500 unit. |
| 14 | 0x7703 | F.drc | Keypad Connect | Keypad cable connected while VSM500 unit under power. | Remove power from the VSM500 unit. Check the keypad cable connection. Reapply power to the VSM500 unit. |
| 15 | 0x3221 | F.LU | Under Voltage while Running | Low input line or temporary loss of input line. | Check input line to verify voltage is within operating specifications. |
| 20 | 0x6311 | F.dnE | DNet EEPROM Fault | DeviceNet option board EEPROM has invalid data. | Use parameter 113 [RESET] to reset option board parameters to factory defaults. |
| 21 | 0x7502 | F.dnU | DNet Unrecoverable Fault | No communication is occurring. Fault occurs when duplicate node address exists or wrong data rate is set. | Check DIP switch settings on the DeviceNet option board for proper data rate and node address. If DIP switches 7 and 8 on the DeviceNet option board are both set to On, check parameter 103 [NV MAC ID] and parameter 104 [NV BAUD RATE] . Then reset the option board. |
| 22 | 0x7500 | F.dnP | No DNet Power | 24 volt network power is not detected. | Check DeviceNet connector at Communication Module. Also, check network's power supply. |
| 23 | 0x7501 | F.dnL | DNet Lost I/O Connection | Polled I/O connection timed out. | Check DeviceNet master device for correct operation (i.e., powered up, scanner online, etc.). |
| 24 | 0x7504 | F.dnF | DNet Forced Fault | Control Supervisor Object (Class Code 0x29) attribute 17 was set to 1. | Clear fault. |
| 25 | 0x7505 | F.dnC | DNet Comm Fault | Communication failure between DeviceNet option board and unit. | Check the unit cable connecting the DeviceNet option board and VSM500 unit. |

¹Parameter fault codes are viewed in parameter 10 [LAST FAULT]. DeviceNet fault codes are read from Class 0x29, Instance 1, Attribute 13. Display fault codes are viewed on the LED display on the local operator control keypad.

7.4 Solving Potential Problems

| Description | Solution |
|--|--|
| Parameters settings are not taking effect, or switch settings are not taking effect. | <p>Check the setting of DIP switch 10 on the VSM500 unit (Figure 2.3). If this switch is On, then the VSM500 unit uses the settings of the drive parameters in EEPROM. If it is Off, then the VSM500 unit uses the settings of the DIP switches and rotary switches on the board.</p> <ol style="list-style-type: none">1. Set the switch as desired.2. Cycle power to the VSM500 unit. |
| Unit uses an incorrect data rate or node address. | <p>Check the setting of DIP switch 7 and 8 on the DeviceNet option board (see figure 2.3). If both switches are On, the VSM500 unit uses the node address set in parameter 103 [NV MAC ID] and the data rate set in parameter 104 [NV BAUD RATE]. Otherwise, the VSM500 unit uses the values set using the DIP switches as specified in section 2.5.</p> |

Technical Specifications

Electrical

Network Supply Voltage: 11 to 25 VDC

Power Consumption: 0.5 Watt maximum

Node Current Consumption: 40 mA (Use this value to size the network current draw from the power supply.)

Environmental

Ambient Temperature

Operating: 0 to 40 °C (32 to 104 °F)

Storage: -40 to 85 °C (-40 to 185 °F)

Relative Humidity: 0 to 95% non-condensing

Vibration: 1.0 G Operational

2.5 G Non-operational

Shock: 15.0 G Operational

30.0 G Non-operational

Altitude: 1,000 m (3,300 ft.) without derating

Communications

Protocol: DeviceNet

Data Rates: 125, 250, 500 k BPS

Distance maximum: 500 m (1640 ft.) @ 125 k BPS

200 m (820 ft.) @ 250 k BPS

100 m (328 ft.) @ 500 k BPS

Mechanical

Dimensions

Height: 120.65 mm (4.75 in.)

Width: 155.57 mm (6.125 in.)

Depth: 12.70 mm (0.5 in.)

APPENDIX B

Parameters

Appendix B contains a list of the parameters in the VSM500 Integrated drive/motor and the DeviceNet option board.

B.1 Product Codes and EDS Files

| Catalog Number | Power Rating (HP) | Voltage | Motor Frame | Version | Product Code | EDS File |
|----------------|-------------------|---------------|-------------|---------|--------------|---------------|
| 10XS1011 | 1 | 115V, 1 Phase | 56C | Std | 137 | 137.cod/3.eds |
| 10XW1011 | 1 | 115V, 1 Phase | 56C | Loc | 138 | 138.cod/3.eds |
| 11XS1011 | 1 | 115V, 1 Phase | 143TC | Std | 139 | 139.cod/3.eds |
| 11XW1011 | 1 | 115V, 1 Phase | 143TC | Loc | 140 | 140.cod/3.eds |
| 10XS3011 | 1 | 230V, 1 Phase | 56C | Std | 141 | 141.cod/3.eds |
| 10XW3011 | 1 | 230V, 1 Phase | 56C | Loc | 142 | 142.cod/3.eds |
| 11XS3011 | 1 | 230V, 1 Phase | 143TC | Std | 143 | 143.cod/3.eds |
| 11XW3011 | 1 | 230V, 1 Phase | 143TC | Loc | 144 | 144.cod/3.eds |
| 21XS3011 | 2 | 230V, 1 Phase | 145TC | Std | 145 | 145.cod/3.eds |
| 21XW3011 | 2 | 230V, 1 Phase | 145TC | Loc | 146 | 146.cod/3.eds |
| 10XS2011 | 1 | 230V, 3 Phase | 56C | Std | 147 | 147.cod/3.eds |
| 10XW2011 | 1 | 230V, 3 Phase | 56C | Loc | 148 | 148.cod/3.eds |
| 11XS2011 | 1 | 230V, 3 Phase | 143TC | Std | 149 | 149.cod/3.eds |
| 11XW2011 | 1 | 230V, 3 Phase | 143TC | Loc | 150 | 150.cod/3.eds |
| 21XS2011 | 2 | 230V, 3 Phase | 145TC | Std | 151 | 151.cod/3.eds |
| 21XW2011 | 2 | 230V, 3 Phase | 145TC | Loc | 152 | 152.cod/3.eds |
| 10XS4011 | 1 | 460V, 3 Phase | 56C | Std | 153 | 153.cod/3.eds |
| 10XW4011 | 1 | 460V, 3 Phase | 56C | Loc | 154 | 154.cod/3.eds |
| 11XS4011 | 1 | 460V, 3 Phase | 143TC | Std | 155 | 155.cod/3.eds |
| 11XW4011 | 1 | 460V, 3 Phase | 143TC | Loc | 156 | 156.cod/3.eds |
| 21XS4011 | 2 | 460V, 3 Phase | 145TC | Std | 157 | 157.cod/3.eds |
| 21XW4011 | 2 | 460V, 3 Phase | 145TC | Loc | 158 | 158.cod/3.eds |
| 32XS4011 | 3 | 460V, 3 Phase | 182TC | Std | 159 | 159.cod/3.eds |
| 32XW4011 | 3 | 460V, 3 Phase | 182TC | Loc | 160 | 160.cod/3.eds |
| 52XS4011 | 5 | 460V, 3 Phase | 184TC | Std | 161 | 161.cod/3.eds |
| 52XW4011 | 5 | 460V, 3 Phase | 184TC | Loc | 162 | 162.cod/3.eds |

B.2 Parameter Groups

Parameters in the VSM500 Integrated drive/motor are grouped into either the Display group or the Program group. Parameters in the Display group are read only. You can get their values, but you cannot change their values. Parameters in the Program group are read/write. You can get and set their values. When a DeviceNet option board is connected, its parameters are grouped in the DNet Config group. Its parameters are also read/write. Figure B.1 illustrates the parameter groups of a VSM500 Integrated drive/motor with a DeviceNet option board.

Table B.1 – Parameter Groups

| Drive Display | Drive Program | DNet Config |
|-----------------------------|----------------------------|-----------------------|
| 01 - Command Frequency | 30 - Minimum Frequency | 101 - Switches MAC ID |
| 02 - Output Frequency | 31 - Maximum Frequency | 102 - Switches Baud |
| 03 - Output Voltage | 32 - Accel Time | 103 - NV MAC ID |
| 04 - Output Current | 33 - Decel Time | 104 - NV Baud Rate |
| 05 - Load Current | 34 - Start Source | 105 - Bus Off Error |
| 06 - Bus Voltage | 35 - Run On Power Up | 106 - Bus Off Count |
| 07 - Power Unit Temperature | 36 - Speed Ref Source | 107 - Output Assembly |
| 08 - Analog Input | 37 - Relay Control Output | 108 - Input Assembly |
| 09 - TB Input Status | 38 - Auto Restart Attempts | 109 - DNet Fault Mode |
| 10 - Last Fault | 39 - Auto Restart Delay | 110 - DNet Idle Mode |
| | 40 - Torque Curve | 111 - DNet SW Mode |
| | 41 - Torque Boost | 112 - COS Mask |
| | 42 - Base Frequency | 113 - Reset |
| | 43 - Base Voltage | |
| | 44 - Stop Select | |
| | 45 - Reverse Disable | |
| | 46 - IR Compensation | |
| | 47 - Slip Compensation | |
| | 48 - Analog Minimum | |
| | 49 - Analog Maximum | |
| | 50 - Fault Reset | |
| | 51 - Preset Speed 1 | |
| | 52 - Preset Speed 2 | |
| | 53 - Preset Speed 3 | |
| | 54 - Preset Speed 4 | |
| | 55 - Preset Speed 5 | |
| | 56 - Preset Speed 6 | |
| | 57 - Preset Speed 7 | |

B.3 Parameter List

| # | Object Mapping | Name and Description | Access Rule ¹ | Units/ Range | Factory Default |
|---------------------------------|----------------|--|--------------------------|-----------------------|-----------------|
| Drive Display Parameters | | | | | |
| 01 | 0x0F-1-1 | Command Frequency Value of the presently selected speed reference. | Get | 0.1 Hz | None |
| 02 | 0x0F-2-1 | Output Frequency Output frequency to the motor. | Get | 0.1 Hz | None |
| 03 | 0x0F-3-1 | Output Voltage Output voltage to the motor. | Get | 1 Volt | None |
| 04 | 0x0F-4-1 | Output Current Output current to the motor. | Get | 0.1% of Rated Current | None |
| 05 | 0x0F-5-1 | Load Current Output current to the motor due to the load. | Get | 0.1% of Rated Current | None |
| 06 | 0x0F-6-1 | Bus Voltage DC Bus voltage level. | Get | 1 Volt | None |
| 07 | 0x0F-7-1 | Power Unit Temperature Temperature of the VSM500 unit. | Get | 1 °C | None |
| 08 | 0x0F-8-1 | Analog Input The value of the analog speed reference input (terminal 2 or 3 on the control signal terminal block). | Get | 0.1% of Full Scale | None |
| 09 | 0x0F-9-1 | TB Input Status The on (1) and off (0) state of the inputs to the control signal terminal block: | Get | Bits | None |
| 10 | 0x0F-10-1 | Last Fault Fault number for the most recent fault. 0 = No Fault 1 = Function Loss 2 = Over Current 3 = Motor Overload 4 = Over Voltage 5 = Under Voltage Stop 6 = Over Temperature 7 = Communication Loss 8 = Parameter Checksum 9 = EEPROM Drive ID 10 = Keypad Disconnect 11 = Keypad Fixed Pattern 12 = Keypad Redundant Start 13 = TB Redundant Start 14 = Keypad Connect 15 = Under Voltage Running 20 = DNet EEPROM Fault 21 = DNet Unrecoverable Fault 22 = No DNet Power 23 = DNetLost/I/OConnection 24 = DNet Forced Fault Refer to Chapter 7 for troubleshooting procedures. | Get | 0 to 24 | None |

¹ Get = Read. Set = Write. Set access is allowed only if DIP switch 10 on the VSM500 Integrated drive/motor is set to On (figure 2.3).

² The parameter can be set only when the drive is stopped.

³ The parameter can be set only then the VSM500 Integrated drive/motor does not have an active I/O connection.

| # | Object Mapping | Name and Description | Access Rule ¹ | Units/ Range | Factory Default |
|---------------------------------|----------------|--|--------------------------|-----------------------|-----------------|
| Drive Program Parameters | | | | | |
| 30 | 0x0F-30-1 | Minimum Frequency Lowest frequency that the drive will output continuously. Its value must be less than parameter 31 - [MAXIMUM FREQUENCY]. | Get/ Set ² | 0 Hz to 60 Hz | 0 Hz |
| 31 | 0x0F-31-1 | Maximum Frequency Highest frequency that the drive will output. Its value must be greater than the value of parameter 30 [MINIMUM FREQUENCY]. | Get/ Set ² | 50 Hz to 120 Hz | 60 Hz |
| 32 | 0x0F-32-1 | Accel Time Time for the drive to ramp from 0 Hz to the value of parameter 31 [MAXIMUM FREQUENCY]. The accel time is linear. | Get/ Set | 1.0 Sec. to 90.0 Sec. | 5.0 Sec. |
| 33 | 0x0F-33-1 | Decel Time Time for the drive to ramp from the value of parameter 31 [MAXIMUM FREQUENCY] to 0 Hz. The decel ramp is linear. | Get/ Set | 1.0 Sec. to 90.0 Sec. | 5.0 Sec. |
| 34 | 0x0F-34-1 | Start Source Source of the start command. 0 = Keypad 1 = Terminal Block 2 = Network Important: The drive requires a stop input at the control terminal block, regardless of the start source selection. | Get/ Set ² | 0 to 2 | 0 |
| 35 | 0x0F-35-1 | Run On Power Up If enabled, output power is applied to the motor automatically at drive power up. 0 = Disabled 1 = Enabled Important: This parameter is ignored if parameter 34 [START SOURCE] is set to 2 = Network. The drive will start in network mode if the network run command is set. <div style="border: 1px solid black; padding: 5px; margin-top: 10px;"> ATTENTION: When this feature is enabled, the drive may start at any moment. This feature may only be used as outlined in NFPA 79, Under Voltage Protection for specialized applications. Failure to observe these precautions could result in severe bodily injury or loss of life.</div> | Get/ Set | 0 to 1 | 0 |
| 36 | 0x0F-36-1 | Speed Reference Source Source of the speed reference. 0 = Keypad/Preset Speeds 1 = Analog/Preset Speeds 2 = Network | Get/ Set | 0 to 2 | 0 |
| 37 | 0x0F-37-1 | Relay Control Status indication provided by the normally open (N.O.) relay control output (control terminals 19 and 20). Refer to the VSM500 Integrated Drive/Motor User Manual information on these terminals. 0 = Running 1 = No Fault 2 = At Reference | Get/ Set | 0 to 2 | 0 |
| 38 | 0x0F-38-1 | Auto Restart Attempts Maximum number of times that the drive will try to reset a fault. | Get/ Set | 0 to 10 | 0 |

¹ Get = Read. Set = Write. Set access is allowed only if DIP switch 10 on the VSM500 Integrated drive/motor is set to On (figure 2.3).

² The parameter can be set only when the drive is stopped.

³ The parameter can be set only when the VSM500 Integrated drive/motor does not have an active I/O connection.

| # | Object Mapping | Name and Description | Access Rule ¹ | Units/ Range | Factory Default |
|---|----------------|--|--------------------------|---------------------------|------------------|
| Drive Program Parameters (continued) | | | | | |
| 39 | 0x0F-39-1 | Auto Restart Delay Time between restart attempts. | Get/ Set | 1 Sec. to 60 Sec. | 5 Sec. |
| 40 | 0x0F-40-1 | Torque Curve Type of torque curve used by the VSM500 unit. A variable torque curve provides a squared V/Hz curve, 110% electronic thermal overload, and 110% current limit for one minute. A constant torque curve provides a linear V/Hz curve, 150% electronic thermal overload, and 150% current limit for one minute. 0 = Variable Torque 1 = Constant Torque | Get/ Set | 0 to 1 | 0 |
| 41 | 0x0F-41-1 | Torque Boost Commanded voltage when the drive output frequency is 0 Hz. | Get/ Set | 0.0% to 250.0% | 100.0% |
| 42 | 0x0F-42-1 | Base Frequency Set value to rated nameplate frequency of the motor. | Get/ Set | 10 Hz to 120 Hz | 60 Hz |
| 43 | 0x0F-43-1 | Base Voltage Commanded voltage when the drive output frequency is equal to parameter 42 [BASE FREQUENCY] . | Get/ Set | 20 to Rated Voltage | Rated Voltage |
| 44 | 0x0F-44-1 | Stop Select Stopping mode used by the drive when a stop is initiated. 0 = Coast to stop 1 = Ramp to stop | Get/ Set | 0 to 1 | 0 |
| 45 | 0x0F-45-1 | Reverse Disable Disables reverse rotation of the motor. 0 = Reverse enabled 1 = Reverse disabled | Get/ Set ² | 0 to 1 | 0 |
| 46 | 0x0F-46-1 | IR Compensation Compensation for the voltage drop across the stator resistance in an induction motor. A voltage is added to the commanded output voltage based on the load current. The default value of 100% is the factory determined optimum for the drive. It can be adjusted higher or lower to suit the needs of the application. A setting of 0% disables this function. | Get/ Set | 0% to 150% | 100% |
| 47 | 0x0F-47-1 | Slip Compensation Compensation for the inherent slip in an induction motor. A frequency is added to the commanded output frequency based on load current. The default value of 100% is the factory determined optimum for the drive. It can be adjusted higher or lower to suit the needs of the application. A setting of 0% disables this function. | Get/ Set | 0.0% to 150.0% | 100.0% |
| 48 | 0x0F-48-1 | Analog Minimum The percent of analog input used to represent parameter 30 [MINIMUM FREQUENCY] . If the minimum analog input equals minimum frequency, no action is needed. If it is desired to adjust the analog input to equal parameter 30 [MINIMUM FREQUENCY] , use parameter 08 -[ANALOG INPUT] to adjust the analog input to the desired level and then enter the value in parameter 48. | Get/ Set ² | 0.0% to 100.0% | 0% |

¹ Get = Read. Set = Write. Set access is allowed only if DIP switch 10 on the VSM500 Integrated drive/motor is set to On (figure 2.3).

² The parameter can be set only when the drive is stopped.

³ The parameter can be set only then the VSM500 Integrated drive/motor does not have an active I/O connection.

| | Object Mapping | Name and Description | Access Rule ¹ | Units/ Range | Factory Default |
|---|----------------|---|--------------------------|-----------------------|-----------------|
| Drive Program Parameters (continued) | | | | | |
| 49 | 0x0F-49-1 | Analog Maximum The percent of analog input used to represent parameter 31 [MAXIMUM FREQUENCY] . If the maximum analog input equals maximum frequency, no action is needed. If it is desired to adjust the analog input to equal parameter 31 [MAXIMUM FREQUENCY] , use parameter 08 [ANALOG INPUT] to adjust the analog input to the desired level and then enter the value in parameter 49. | Get/ Set ² | 0.0% to 100.0% | 100.0% |
| 50 | 0x0F-50-1 | Fault Reset Resets the drive after a fault. This parameter is a command. It will be reset to 0 = No Action after the command is completed. 0 = No Action 1 = Reset Fault | Get/ Set ² | 0 to 1 | 0 |
| 51 | 0x0F-51-1 | Preset Speed 1 Programmed value that sets the frequency that the drive outputs when this preset is selected. | Get/ Set | 0.0 Hz to 120.0 Hz | 10.0 Hz |
| 52 | 0x0F-52-1 | Preset Speed 2 Programmed value that sets the frequency that the drive outputs when this preset is selected. | Get/ Set | 0.0 Hz to 120.0 Hz | 20.0 Hz |
| 53 | 0x0F-53-1 | Preset Speed 3 Programmed value that sets the frequency that the drive outputs when this preset is selected. | Get/ Set | 0.0 Hz to 120.0 Hz | 30.0 Hz |
| 54 | 0x0F-54-1 | Preset Speed 4 Programmed value that sets the frequency that the drive outputs when this preset is selected. | Get/ Set | 0.0 Hz to 120.0 Hz | 40.0 Hz |
| 55 | 0x0F-55-1 | Preset Speed 5 Programmed value that sets the frequency that the drive outputs when this preset is selected. | Get/ Set | 0.0 Hz to 120.0 Hz | 50.0 Hz |
| 56 | 0x0F-56-1 | Preset Speed 6 Programmed value that sets the frequency that the drive outputs when this preset is selected. | Get/ Set | 0.0 Hz to 120.0 Hz | 60.0 Hz |
| 57 | 0x0F-57-1 | Preset Speed 7 Programmed value that sets the frequency that the drive outputs when this preset is selected. | Get/ Set | 0.0 Hz to 120.0 Hz | 70.0 Hz |
| DeviceNet Parameters | | | | | |
| 101 | 0x0F-101-1 | Switches MAC ID The state of the node address DIP switches (1 - 6). This address may not reflect the present address of the module if the baud rate DIP switches are set to 3. In this case, parameter 103 [NV MAC ID] is used. | Get | 0 to 63 | 63 |
| 102 | 0x0F-102-1 | Switches Baud The state of the baud rate DIP switches (7 - 8). 0 = 125K BPS 1 = 250K BPS 2 = 500K BPS 3 = Use nonvolatile parameters for node address and baud rate settings. | Get | 0 to 3 | 0 |

¹ Get = Read. Set = Write. Set access is allowed only if DIP switch 10 on the VSM500 Integrated drive/motor is set to On (figure 2.3).

² The parameter can be set only when the drive is stopped.



³ The parameter can be set only then the VSM500 Integrated drive/motor does not have an active I/O connection.

| | Object Mapping | Name and Description | Access Rule ¹ | Units/ Range | Factory Default |
|---|----------------|--|--------------------------|--------------|-----------------|
| DeviceNet Parameters (continued) | | | | | |
| 103 | 0x0F-103-1 | NV MAC ID Node address independent of the node address DIP switches. To use this address, set both baud rate switches to On before power up. Changes to this parameter take effect only after power is cycled. | Get/ Set | 0 to 63 | 63 |
| 104 | 0x0F-104-1 | NV Baud Rate Baud address independent of the baud rate DIP switches. To use this baud rate, set both baud rate switches to On before power up. Changes to this parameter take effect only after power is cycled. If you use the autobaud option, another node on the network must set the data rate. 0 = 125 K BPS 1 = 250 K BPS 2 = 500 K BPS 3 = Autobaud | Get/ Set | 0 to 3 | 3 |
| 105 | 0x0F-105-1 | Bus Off Error Action of the DeviceNet option board during a CAN Bus Off condition. 0 = Hold CAN chip in its bus off (reset) state when bus off is detected. 1 = If possible, fully reset the CAN chip and continue communicating when a bus off condition is detected. | Get/ Set | 0 to 1 | 0 |
| 106 | 0x0F-106-1 | Bus Off Count The number of times the CAN chip went to a bus off state. The counter stops counting when the count reaches 255. Any write to this parameter will reset the counter to 0. | Get/ Set | 0 to 255 | 0 |
| 107 | 0x0F-107-1 | Output Assembly The output assembly instance that is used for polled messaging with the master. The output assembly defines the data format that the VSM500 unit receives from the master. This parameter determines the format of data being sent to the VSM500 unit by the master. It is named <i>output assembly</i> because the DeviceNet specification refers to all assemblies as they relate to the master. The following assembly instances are valid for this parameter: 0 = No Data (0 bytes) 1 = Basic Contactor Output (1 byte) 2 = Two Command Contactor Output (1 byte) 3 = Basic Overload Output (1 byte) 4 = Basic Motor Control Output (1 byte) 5 = 2 Command Motor Control (1 byte) 20 = Basic Speed Control (4 bytes) 21 = Extended Speed Control (4 bytes) 100 = Speed Control in Hz (4 bytes) 106 = Preset Control with speed (4 bytes) Refer to the Assembly Object in <Link>Appendix C for the formats of the output assembly. | Get/ Set ³ | 0 to 106 | 20 |

¹ Get = Read. Set = Write. Set access is allowed only if DIP switch 10 on the VSM500 Integrated drive/motor is set to On (figure 2.3).

² The parameter can be set only when the drive is stopped.

³ The parameter can be set only then the VSM500 Integrated drive/motor does not have an active I/O connection.

| | Object Mapping | Name and Description | Access Rule ¹ | Units/ Range | Factory Default |
|---|----------------|--|--------------------------|-----------------|-----------------|
| DeviceNet Parameters (continued) | | | | | |
| 108 | 0x0F-108-1 | <p>Input Assembly</p> <p>The input assembly instance that is used for polled messaging with the master. The input assembly defines the data format that the drive sends to the master in response to a polled message from the master. This parameter determines the format of data being sent to the master. It is named input assembly because the DeviceNet specification refers to all assemblies as they relate to the master. The following assembly instances are valid for this parameter:</p> <p>0 = No Data (0 bytes) 50 = Basic Overload Input (1 byte) 51 = Extended Overload Input (1 byte) 52 = Basic Motor Control Input (1 byte) 53 = Extended Motor Control Input (1 byte) 54 = Extended Motor Control 2 (1 byte) 70 = Basic Speed Control Input (4 bytes) 71 = Extended Speed Control Input (4 bytes)</p> <p>Refer to the Assembly Object in section C.5 (Appendix C) for the formats of the input assembly.</p> | Get/ Set ³ | 0 to 71 | 70 |
| 109 | 0x0F-109-1 | <p>DNet Fault Mode</p> <p>The action of the VSM500 unit when a communication fault such as loss of DeviceNet power occurs. The following behavior choices are used:</p> <p>0 = Fault the VSM500 unit and issue a stop command 1 = Ignore the communication fault</p> <div style="border: 1px solid black; padding: 5px; margin-top: 10px;">  <p>ATTENTION: This parameter determines the action of the option and connected VSM500 unit if communications are disrupted. By default, this parameter faults the VSM500 unit. You can set this parameter so that the VSM500 unit continues to run. Failure to observe these precautions could result in bodily injury or damage to equipment.</p> </div> | Get/ Set | 0 to 1 | 0 |
| 110 | 0x0F-110-1 | <p>DNet Idle Mode</p> <p>The action of the VSM500 unit when the scanner is in idle mode.</p> <p>0 = Zero data 1 = Hold last state</p> <div style="border: 1px solid black; padding: 5px; margin-top: 10px;">  <p>ATTENTION: This parameter determines the action of the option and connected VSM500 unit if the scanner is put in idle mode. By default, this parameter stops the VSM500 unit. You can set this parameter so that the VSM500 unit continues to run. Failure to observe these precautions could result in damage to, or destruction of, the equipment.</p> </div> | Get/ Set | 0 to 1 | 0 |
| 111 | 0x0F-111-1 | <p>DNet SW Version</p> <p>Software version of the DeviceNet option board board. The number is in the form of xx.yyy where xx indicates the major revision level and yyy indicates the minor revision level.</p> | Get | 0.000 to 10.000 | None |

¹ Get = Read. Set = Write. Set access is allowed only if DIP switch 10 on the VSM500 Integrated drive/motor is set to On (figure 2.3).

² The parameter can be set only when the drive is stopped.

³ The parameter can be set only then the VSM500 Integrated drive/motor does not have an active I/O connection.

| | Object Mapping | Name and Description | Access Rule ¹ | Units/ Range | Factory Default |
|---|----------------|---|--------------------------|--|--|
| DeviceNet Parameters (continued) | | | | | |
| 112 | 0x0F-112-1 | <p>COS Mask A 16-bit mask used to enable automatic change of state messages. A 0 disables the indicated status from causing an automatic message. A 1 enables the status. The mask is applied to the defined input status assembly. The default value is 0xFFFF.</p> | Get/ Set | 0000 0000 0000 0000 (0x00) to 1111 1111 1111 1111 (0xFFFF) | 1111 1111 1111 1111 (0xFFFF) |
| 113 | 0x0F-113-1 | <p>Reset Reset functions for the option and VSM500 unit. This parameter is a command. It will be reset to 0 = Ready after the command is completed.</p> <p>0 = Ready (No action.) 1 = Reset DNet (Resets the DeviceNet option board board so that new node address or data rate settings are used.) 2 = Default DNet (Restores the parameters in the DeviceNet group to their factory-default settings.) 3 = Default Drive (Restores the parameters in the Drive Program group to their factory-default settings.)</p> | Get/ Set ² | 0 to 3 | 0 |

¹ Get = Read. Set = Write. Set access is allowed only if DIP switch 10 on the VSM500 Integrated drive/motor is set to On (figure 2.3).

² The parameter can be set only when the drive is stopped.

³ The parameter can be set only then the VSM500 Integrated drive/motor does not have an active I/O connection.

DeviceNet Objects

This appendix provides information on the DeviceNet objects supported by the VSM500 Integrated drive/motor for DeviceNet.

C.1 DeviceNet Message Types

The DeviceNet option board supports the following message types:

| CAN Identifier Field | Group 1 Message Type |
|----------------------|--------------------------------|
| 01101xxxxx | Slave's I/O COS/Cyclic Message |
| 01111xxxxx | Slave Poll Response Messages |

| CAN Identifier Field | Group 2 Message Type |
|----------------------|---|
| 10xxxxx010 | Master's COS/Cyclic Acknowledge Message |
| 10xxxxx011 | Slave Explicit Response Messages |
| 10xxxxx100 | Master Explicit Request Messages |
| 10xxxxx101 | Master I/O Poll Command Messages |
| 10xxxxx111 | Duplicate MAC ID Check Messages |

| CAN Identifier Field | Group 3 Message Type |
|----------------------|--|
| 11000xxxxx | Explicit Request/Response Messages |
| 11001xxxxx | |
| 11010xxxxx | |
| 11011xxxxx | |
| 11100xxxxx | |
| 11101xxxxx | Unconnected Explicit Response Messages |
| 11110xxxxx | Unconnected Explicit Request Messages |

| CAN Identifier Field | Group 4 Message Type |
|----------------------|---|
| 1111101100 | Communication Faulted Response Messages |
| 1111101101 | Communication Faulted Request Messages |

C.2 Class Code 0x01 – Identity Object

Class Attributes

| Attribute ID | Access Rule | Name | Data Type | Value |
|--------------|-------------|---------------------|-----------|-------|
| 1 | Get | Revision | UINT | 1 |
| 2 | Get | Max Instance | UINT | 2 |
| 3 | Get | Number of Instances | UINT | 2 |
| 6 | Get | Max ID Class | UINT | 7 |
| 7 | Get | Max ID Instance | UINT | 7 |

Number of Instances: 2

Instance 1 Attributes Drive Instance

| Attribute ID | Access Rule | Name | Data Type | Value |
|--------------|-------------|---|---------------------------------|---|
| 1 | Get | Vendor ID | UINT | 5 |
| 2 | Get | Device Type | UINT | 2 |
| 3 | Get | Product Code | UINT | See Product Codes in Appendix B |
| 4 | Get | Revision Major Revision Minor Revision | Structure of USINT USINT | 3 2 |
| 5 | Get | Status | WORD | Bit 0 = Owned Bit 2 = Configured Bit 10 = Recoverable Fault Bit 11 = Unrecoverable Fault |
| 6 | Get | Serial Number | UDINT | Unique 32 bit number |
| 7 | Get | Product Name String Length ASCII String | Structure of USINT STRING | 32 See Product Codes in Appendix B |
| 9 | Get | Configuration Consistency Value | UINT | Checksum |

Instance 2 Attributes: DeviceNet Option Instance

| Attribute ID | Access Rule | Name | Data Type | Value |
|--------------|-------------|---|---------------------------------|---|
| 1 | Get | Vendor ID | UINT | 5 |
| 2 | Get | Device Type | UINT | 12 |
| 3 | Get | Product Code | UINT | 75 |
| 4 | Get | Revision Major Revision Minor Revision | Structure of USINT USINT | 1 7 |
| 5 | Get | Status | WORD | Bit 0 = Owned Bit 2 = Configured Bit 10 = Recoverable Fault Bit 11 = Unrecoverable Fault |
| 6 | Get | Serial Number | UDINT | Unique 32 bit number |
| 7 | Get | Product Name String Length ASCII String | Structure of USINT STRING | 29 "VSM500 DeviceNet Interface" |

Common Services

| Service Code | Implemented for | | Service Name |
|--------------|-----------------|----------|---------------------------|
| | Class | Instance | |
| 0x05 | No | Yes | Reset |
| 0x0E | Yes | Yes | Get_Attribute_Single |
| 0x11 | Yes | No | Find_Next_Object_Instance |

C.3 Class Code 0x02 – Message Router Object

Class Attributes

| Attribute ID | Access Rule | Name | Data Type | Value |
|--------------|-------------|-----------------|-----------|-------|
| 1 | Get | Revision | UINT | 1 |
| 6 | Get | Max ID Class | UINT | 7 |
| 7 | Get | Max ID Instance | UINT | 4 |

Instance Attributes

| Attribute ID | Access Rule | Name | Data Type | Value |
|--------------|-------------|--------------------|----------------|--|
| 2 | Get | Number Available | UINT | 8 |
| 3 | Get | Number Active | UINT | Number of connections currently used by system components |
| 4 | Get | Active Connections | Array of: UINT | A list of the connection IDs of the currently active connections |

Common Services

| Service Code | Implemented for | | Service Name |
|--------------|-----------------|----------|----------------------|
| | Class | Instance | |
| 0x0E | Yes | Yes | Get_Attribute_Single |

C.4 Class Code 0x03 – DeviceNet Object

Class Attributes

| Attribute ID | Access Rule | Name | Data Type | Value |
|--------------|-------------|----------|-----------|-------|
| 1 | Get | Revision | UINT | 2 |

Instance 1 Attributes

| Attribute ID | Access Rule | Name | Data Type | Value |
|--------------|-------------|--|--------------------------------|--|
| 1 | Get/Set | MAC ID | USINT | 0 to 63 |
| 2 | Get/Set | Baud Rate | USINT | 0 to 2 |
| 3 | Get/Set | Bus Off Interrupt | BOOL | 0 = Hold in error state 1 = Reset CAN chip |
| 4 | Get/Set | Bus-off Counter | USINT | 0 to 255 |
| 5 | Get | Allocation Information Allocation Choice Master Node Address | Structure of: Byte USINT | Allocation Byte ¹ 0 to 63 = Address 255 = Unallocated |
| 6 | Get | MAC ID Switch Changed | BOOL | 0 = No Change 1 = Change since last reset or power up |
| 7 | Get | Baud Rate Switch Changed | BOOL | 0 = No Change 1 = Change since last reset or power up |
| 8 | Get | MAC ID Switch Value | USINT | 0 to 63 |
| 9 | Get | Baud Rate Switch Value | USINT | 0 to 3 |

¹Allocation Byte

Bit 0 = Explicit Messaging

Bit 1 = Polled I/O

Bit 4 = Change of State

Bit 5 = Cyclic

Bit 6 = Acknowledge Suppressed

Common Services

| Service Code | Implemented for | | Service Name |
|--------------|-----------------|----------|--------------------------------------|
| | Class | Instance | |
| 0x0E | Yes | Yes | Get_Attribute_Single |
| 0x10 | No | Yes | Set_Attribute_Single |
| 0x4B | No | Yes | Allocate_Master/Slave_Connection_Set |
| 0x4C | No | Yes | Release_Master/Slave_Connection_Set |

C.5 Class Code 0x04 – Assembly Object

Class Attributes

| Attribute ID | Access Rule | Name | Data Type | Value |
|--------------|-------------|--------------|-----------|-------|
| 1 | Get | Revision | UINT | 2 |
| 2 | Get | Max Instance | UINT | 106 |

Instance 1 to 106 Attributes: I/O Instances

| Attribute ID | Access Rule | Name | Data Type | Min/Max | Default | Description |
|--------------|-------------|------|-----------|---------|---------|---|
| 3 | Get | Data | | | | See instance data format for individual I/O assemblies on pages C-7 to C-9. |

Common Services

| Service Code | Implemented for | | Service Name |
|--------------|-----------------|----------|----------------------|
| | Class | Instance | |
| 0x0E | No | Yes | Get_Attribute_Single |
| 0x10 | No | Yes | Set_Attribute_Single |

Instance Data Format: Output Assemblies

| Instance 1 Data Format (Basic Contactor Output Assembly) | | | | | | | | |
|--|-------|-------|-------|-------|-------|-------|-------|-------|
| Byte | Bit 7 | Bit 6 | Bit 5 | Bit 4 | Bit 3 | Bit 2 | Bit 1 | Bit 0 |
| 0 | | | | | | | | Run |

| Instance 2 Data Format (Basic Overload Output Assembly) | | | | | | | | |
|---|-------|-------|-------|-------|-------|-------------|-------|-------|
| Byte | Bit 7 | Bit 6 | Bit 5 | Bit 4 | Bit 3 | Bit 2 | Bit 1 | Bit 0 |
| 0 | | | | | | Fault Reset | | |

| Instance 3 Data Format (Basic Motor Starter Output Assembly) | | | | | | | | |
|--|-------|-------|-------|-------|-------|-------------|-------|-------|
| Byte | Bit 7 | Bit 6 | Bit 5 | Bit 4 | Bit 3 | Bit 2 | Bit 1 | Bit 0 |
| 0 | | | | | | Fault Reset | | Run |

| Instance 4 Data Format (Extended Contactor Output Assembly) | | | | | | | | |
|---|-------|-------|-------|-------|-------|-------|--------|--------|
| Byte | Bit 7 | Bit 6 | Bit 5 | Bit 4 | Bit 3 | Bit 2 | Bit 1 | Bit 0 |
| 0 | | | | | | | RunRev | RunFwd |

| Instance 5 Data Format (Extended Motor Starter Output Assembly) | | | | | | | | |
|---|-------|-------|-------|-------|-------|-------------|--------|--------|
| Byte | Bit 7 | Bit 6 | Bit 5 | Bit 4 | Bit 3 | Bit 2 | Bit 1 | Bit 0 |
| 0 | | | | | | Fault Reset | RunRev | RunFwd |

| Instance 20 Data Format (Basic Speed Control Output Assembly) | | | | | | | | |
|---|---------------------------------|-------|-------|-------|-------|-------------|-------|--------|
| Byte | Bit 7 | Bit 6 | Bit 5 | Bit 4 | Bit 3 | Bit 2 | Bit 1 | Bit 0 |
| 0 | | | | | | Fault Reset | | RunFwd |
| 1 | | | | | | | | |
| 2 ¹ | Speed Reference RPM (Low Byte) | | | | | | | |
| 3 ¹ | Speed Reference RPM (High Byte) | | | | | | | |

| Instance 21 Data Format (Reversing Speed Control Output Assembly) | | | | | | | | |
|---|---------------------------------|--------|-------------|-------|-------|-------------|--------|--------|
| Byte | Bit 7 | Bit 6 | Bit 5 | Bit 4 | Bit 3 | Bit 2 | Bit 1 | Bit 0 |
| 0 | | NetRef | Net Control | | | Fault Reset | RunRev | RunFwd |
| 1 | | | | | | | | |
| 2 ¹ | Speed Reference RPM (Low Byte) | | | | | | | |
| 3 ¹ | Speed Reference RPM (High Byte) | | | | | | | |

| Instance 100 Data Format (Reversing Speed Control Output Assembly (Hz)) | | | | | | | | |
|---|--|-------|-------|-------|-------|-------------|--------|--------|
| Byte | Bit 7 | Bit 6 | Bit 5 | Bit 4 | Bit 3 | Bit 2 | Bit 1 | Bit 0 |
| 0 | | | | | | Fault Reset | RunRev | RunFwd |
| 1 | | | | | | | | |
| 2 ¹ | Speed Ref Hz (0.1 Hz) (Low Byte) ² | | | | | | | |
| 3 ¹ | Speed Ref Hz (0.1 Hz) (High Byte) ² | | | | | | | |

¹ If speed references are outside of their min/max limits, the drive ignores them and previous speed reference will be maintained.

² 0 = 0 Hz, 1200 = 120.0 Hz.

Instance Data Format: Output Assemblies (Continued)

| Instance 106 Data Format (Preset Control with Speed) | | | | | | | | |
|--|--|-------|-------|-------|-------|-------------|----------|----------|
| Byte | Bit 7 | Bit 6 | Bit 5 | Bit 4 | Bit 3 | Bit 2 | Bit 1 | Bit 0 |
| 0 | | | | | | Fault Reset | RunRev | RunFwd |
| 1 | | | | | | Preset 2 | Preset 1 | Preset 0 |
| 2 ¹ | Speed Ref Hz (0.1 Hz) (Low Byte) ² | | | | | | | |
| 3 ¹ | Speed Ref Hz (0.1 Hz) (High Byte) ² | | | | | | | |

¹ If speed references are outside of their min/max limits, the drive ignores them and previous speed reference will be maintained.

² 0 = 0 Hz, 1200 = 120.0 Hz.

The following table defines the possible settings of the Preset bits in Instance 106.

| Preset 2 | Preset 1 | Preset 0 | Source of Speed Reference |
|----------|----------|----------|---|
| 0 | 0 | 0 | Speed Ref Hz (bytes 2 and 3 of the output assembly) |
| 0 | 0 | 1 | Parameter 51 [PRESET 1] |
| 0 | 1 | 0 | Parameter 52 [PRESET 2] |
| 0 | 1 | 1 | Parameter 53 [PRESET 3] |
| 1 | 0 | 0 | Parameter 54 [PRESET 4] |
| 1 | 0 | 1 | Parameter 55 [PRESET 5] |
| 1 | 1 | 0 | Parameter 56 [PRESET 6] |
| 1 | 1 | 1 | Parameter 57 [PRESET 7] |

The following table indicates the I/O Assembly Data Attribute mapping for Output Assemblies.

| Data Component Name | Class | | Instance Number | Attribute | |
|---------------------|------------|--------|-----------------|---------------------|--------|
| | Name | Number | | Name | Number |
| RunFwd | Supervisor | 0x29 | 1 | Run 1 | 3 |
| RunRev | Supervisor | 0x29 | 1 | Run 2 | 4 |
| Fault Reset | Supervisor | 0x29 | 1 | Fault Reset | 12 |
| NetCtrl | Supervisor | 0x29 | 1 | NetCtrl | 5 |
| DN Preset Cmd | Supervisor | 0x29 | 1 | DNet Preset Command | 102 |
| NetRef | AC Drive | 0x2A | 1 | Net Ref | 4 |
| Speed Ref RPM | Supervisor | 0x29 | 1 | DNet Speed Ref RPM | 103 |
| Speed Ref Hz | Supervisor | 0x29 | 1 | DNet Speed Ref Hz | 104 |

Instance Data Format: Input Assemblies

| Instance 50 Data Format (Basic Overload/Contactor Input Assembly) | | | | | | | | |
|---|-------|-------|-------|-------|-------|-------|-------|---------|
| Byte | Bit 7 | Bit 6 | Bit 5 | Bit 4 | Bit 3 | Bit 2 | Bit 1 | Bit 0 |
| 0 | | | | | | | | Faulted |

| Instance 51 Data Format (Extended Overload/Contactor Input Assembly) | | | | | | | | |
|--|-------|-------|--------------|-------|-------|-------|-------|---------|
| Byte | Bit 7 | Bit 6 | Bit 5 | Bit 4 | Bit 3 | Bit 2 | Bit 1 | Bit 0 |
| 0 | | | CtrlFrom Net | | | | | Faulted |

| Instance 52 Basic Motor Control | | | | | | | | |
|---------------------------------|-------|-------|-------|-------|-------|----------|-------|--------------|
| Byte | Bit 7 | Bit 6 | Bit 5 | Bit 4 | Bit 3 | Bit 2 | Bit 1 | Bit 0 |
| 0 | | | | | | Running1 | | Faulted/Trip |

| Instance 53 Extended Motor Control 1 (see table for functional assignments) | | | | | | | | |
|---|-------|-------|--------------|-------|-------|----------|-------|--------------|
| Byte | Bit 7 | Bit 6 | Bit 5 | Bit 4 | Bit 3 | Bit 2 | Bit 1 | Bit 0 |
| 0 | | | CtrlFrom Net | Ready | | Running1 | | Faulted/Trip |

| Instance 54 Extended Motor Control 2 (see table for functional assignments) | | | | | | | | |
|---|-------|-------|--------------|-------|----------|----------|-------|--------------|
| Byte | Bit 7 | Bit 6 | Bit 5 | Bit 4 | Bit 3 | Bit 2 | Bit 1 | Bit 0 |
| 0 | | | CtrlFrom Net | Ready | Running2 | Running1 | | Faulted/Trip |

| Instance 70 Data Format (Basic Speed Control Input Assembly) | | | | | | | | |
|--|------------------------------|-------|-------|-------|-------|----------|-------|---------|
| Byte | Bit 7 | Bit 6 | Bit 5 | Bit 4 | Bit 3 | Bit 2 | Bit 1 | Bit 0 |
| 0 | | | | | | Running1 | | Faulted |
| 1 | | | | | | | | |
| 2 | Speed Actual RPM (Low Byte) | | | | | | | |
| 3 | Speed Actual RPM (High Byte) | | | | | | | |

| Instance 71 Data Format (Extended Speed Control Input Assembly) | | | | | | | | |
|---|------------------------------|------------|--------------|-------|-----------------|-----------------|-------|---------|
| Byte | Bit 7 | Bit 6 | Bit 5 | Bit 4 | Bit 3 | Bit 2 | Bit 1 | Bit 0 |
| 0 | AtReference | RefFromNet | CtrlFrom Net | Ready | Running Reverse | Running Forward | | Faulted |
| 1 | | | | | | | | |
| 2 | Speed Actual RPM (Low Byte) | | | | | | | |
| 3 | Speed Actual RPM (High Byte) | | | | | | | |

The following table indicates the I/O Assembly Data Attribute mapping for Input Assemblies.

| Data Component Name | Class | | Instance Number | Attribute | |
|---------------------|------------|--------|-----------------|---------------|--------|
| | Name | Number | | Name | Number |
| Faulted | Supervisor | 0x29 | 1 | Faulted | 10 |
| Running 1 | Supervisor | 0x29 | 1 | Running 1 | 7 |
| Running 2 | Supervisor | 0x29 | 1 | Running 2 | 8 |
| Ready | Supervisor | 0x29 | 1 | Ready | 9 |
| CtrlFromNet | Supervisor | 0x29 | 1 | Ctrl From Net | 15 |
| RefFromNet | AC Drive | 0x2A | 1 | Ref From Net | 29 |
| At Reference | AC Drive | 0x2A | 1 | At Reference | 3 |
| Speed Actual RPM | AC Drive | 0x2A | 1 | Speed Actual | 7 |

C.6 Class Code 0x05 – Connection Object

Class Attribute

| Attribute ID | Access Rule | Name | Data Type | Value |
|--------------|-------------|----------|-----------|-------|
| 1 | Get | Revision | UINT | 1 |

Instance 1 Attributes: Master/Slave Explicit Message Connection

| Attribute ID | Access Rule | Name | Data Type | Value |
|--------------|-------------|---------------------------------|-----------|---|
| 1 | Get | State | USINT | 0 = Nonexistent 1 = Configuring 3 = Established 4 = Timed out 5 = Deferred delete |
| 2 | Get | Instance Type | USINT | 0 = Explicit Message |
| 3 | Get | Transport Class Trigger | USINT | 0x83 |
| 4 | Get | Produced Connection ID | UINT | 10xxxxxx011 xxxxxx = Node Address |
| 5 | Get | Consumed Connection ID | UINT | 10xxxxxx100 xxxxxx = Node Address |
| 6 | Get | Initial Comm. Characteristics | BYTE | 0x21 |
| 7 | Get | Produced Connection Size | UINT | 99 |
| 8 | Get | Consumed Connection Size | UINT | 159 |
| 9 | Get/ Set | Expected Packet Rate | UINT | Timer Resolution of 2 msec. |
| 12 | Get/ Set | Watchdog Timeout Action | USINT | 1 = Auto delete 3 = Deferred delete |
| 13 | Get | Produced Connection Path Length | UINT | 0 |
| 14 | Get | Produced Connection Path | | Null (no data) |
| 15 | Get | Consumed Connection Path Length | UINT | 0 |
| 16 | Get | Consumed Connection Path | | Null (no data) |

Instance 2 Attributes: Polled I/O Connection

| Attribute ID | Access Rule | Name | Data Type | Value |
|--------------|-------------|---------------------------------|-----------|--|
| 1 | Get | State | USINT | 0 = Nonexistent 1 = Configuring 3 = Established 4 = Timed out |
| 2 | Get | Instance Type | USINT | 1 = I/O Message |
| 3 | Get | Transport Class Trigger | USINT | 0x83 |
| 4 | Get | Produced Connection ID | UINT | 01111xxxxxx xxxxxx = Node Address |
| 5 | Get | Consumed Connection ID | UINT | 10xxxxxx101 xxxxxx = Node Address |
| 6 | Get | Initial Comm. Characteristics | BYTE | 0x01 |
| 7 | Get | Produced Connection Size | UINT | 0 to 4 |
| 8 | Get | Consumed Connection Size | UINT | 0 to 4 |
| 9 | Get/Set | Expected Packet Rate | UINT | Timer Resolution of 2 msec |
| 12 | Get/Set | Watchdog Timeout Action | USINT | 0 = Transition to time out 1 = Auto delete 2 = Auto reset |
| 13 | Get | Produced Connection Path Length | UINT | 6 |
| 14 | Get | Produced Connection Path | | 0x20, 0x04, 0x24, XX, 0x30, 0x03 ¹ |
| 15 | Get | Consumed Connection Path Length | UINT | 6 |
| 16 | Get | Consumed Connection Path | | 0x20, 0x04, 0x24, XX, 0x30, 0x03 ¹ |

¹Refer to the DeviceNet specification for a description of the connection path.

Instance 4 Attributes: Change of State/Cyclic I/O Message Connection

| Attribute ID | Access Rule | Name | Data Type | Value |
|--------------|-------------|---------------------------------|-----------|--|
| 1 | Get | State | USINT | 0 = Nonexistent 1 = Configuring 3 = Established 4 = Timed out |
| 2 | Get | Instance Type | USINT | 1 = I/O Message |
| 3 | Get | Transport Class Trigger | USINT | 0x00 = Cyclic, ack inhibited 0x03 = Cyclic 0x10 = COS, ack inhibited 0x13 = COS |
| 4 | Get | Produced Connection ID | UINT | 01101xxxxx xxxxxx = Node Address |
| 5 | Get | Consumed Connection ID | UINT | Ack inhibited 0xFFFF Ack enabled 10xxxxxx010 xxxxxx = Node Address |
| 6 | Get | Initial Comm. Characteristics | BYTE | 0x01 = ack enabled 0x0F = ack inhibited |
| 7 | Get | Produced Connection Size | UINT | 0 to 4 |
| 8 | Get | Consumed Connection Size | UINT | 0 to 4 |
| 9 | Get/Set | Expected Packet Rate | UINT | Timer Resolution of 2 msec |
| 12 | Get/Set | Watchdog Timeout Action | USINT | 0 = Transition to time out 1 = Auto delete 2 = Auto reset |
| 13 | Get | Produced Connection Path Length | UINT | 6 |
| 14 | Get | Produced Connection Path | | 0x20, 0x04, 0x24, XX, 0x30, 0x03 ¹ |
| 15 | Get | Consumed Connection Path Length | UINT | 0 = ack inhibited 1 = ack enabled |
| 16 | Get | Consumed Connection Path | | Ack inhibited Null (no data) Ack enabled 0x20, 0x2B, 0x24, XX, 0x30, 0x01 ¹ |
| 17 | Get/Set | Production Inhibit Time | UINT | Timer Resolution of 2 msec |

¹Refer to the DeviceNet specification for a description of the connection path.

Instances 6 through 10: Explicit Message Connections

| Attribute ID | Access Rule | Name | Data Type | Value |
|--------------|-------------|---------------------------------|-----------|---|
| 1 | Get | State | USINT | 0 = Nonexistent 1 = Configuring 3 = Established 4 = Timed out 5 = Deferred delete |
| 2 | Get | Instance Type | USINT | 0 = Explicit Message |
| 3 | Get | Transport Class Trigger | USINT | 0x83 |
| 4 | Get | Produced Connection ID | UINT | 11yyyxxxxx yyy = Group 3 Message ID xxxxxx = Node Address |
| 5 | Get | Consumed Connection ID | UINT | 11yyyxxxxx yyy = Group 3 Message ID xxxxxx = Client Node Address |
| 6 | Get | Initial Comm. Characteristics | BYTE | 0x33 |
| 7 | Get | Produced Connection Size | UINT | 99 |
| 8 | Get | Consumed Connection Size | UINT | 159 |
| 9 | Get/Set | Expected Packet Rate | UINT | Timer Resolution of 2 msec. |
| 12 | Get/Set | Watchdog Timeout Action | USINT | 1 = Auto delete 3 = Deferred delete |
| 13 | Get | Produced Connection Path Length | UINT | 0 |
| 14 | Get | Produced Connection Path | | Null (no data) |
| 15 | Get | Consumed Connection Path Length | UINT | 0 |
| 16 | Get | Consumed Connection Path | | Null (no data) |

Common Services

| Service Code | Implemented for | | Service Name |
|--------------|-----------------|----------|---------------------------|
| | Class | Instance | |
| 0x05 | No | Yes | Reset |
| 0x0E | Yes | Yes | Get_Attribute_Single |
| 0x10 | No | Yes | Set_Attribute_Single |
| 0x11 | Yes | No | Find_Next_Object_Instance |

C.7 Class Code 0x0F – Parameter Object

Class Attributes

| Attribute ID | Access Rule | Name | Data Type | Value |
|--------------|-------------|---------------------------------|-----------|-------------|
| 1 | Get | Revision | UINT | 1 |
| 2 | Get | Max Instance | UINT | 113 |
| 8 | Get | Parameter Class Descriptor | WORD | 0x0B |
| 9 | Get | Configuration Assembly Instance | UINT | 0 |
| 10 | Get | Native Language | USINT | 0 = English |

Instance 1 through 113 Attributes

| Attribute ID | Access Rule | Name | Data Type | Value |
|--------------|-------------|-----------------------|--------------|---|
| 1 | Get/Set | Parameter Value | (1) | (2) |
| 2 | Get | Link Path Size | USINT | 7 |
| 3 | Get | Link Path | | 0x20, 0x0F, 0x25, XX, XX, 0x30, 0x01 ³ |
| 4 | Get | Descriptor | WORD | Bit 1 Supports enum strings Bit 2 Supports scaling Bit 4 Read only Bit 5 Monitor Bit 6 Extended precision scaling |
| 5 | Get | Data Type | USINT | 1 = 16 bit word 2 = 16 bit unsigned integer 3 = 16 bit signed integer |
| 6 | Get | Data Size | USINT | 2 |
| 7 | Get | Parameter Name String | SHORT_STRING | (2) |
| 8 | Get | Units String | SHORT_STRING | (2) |
| 9 | Get | Help String | SHORT_STRING | 0 |
| 10 | Get | Minimum Value | data type | (2) |
| 11 | Get | Maximum Value | data type | (2) |
| 12 | Get | Default Value | data type | (2) |
| 13 | Get | Scaling Multiplier | UINT | 1 |
| 14 | Get | Scaling Divisor | UINT | 1 |
| 15 | Get | Scaling Base | UINT | 1 |
| 16 | Get | Scaling Offset | INT | 0 |
| 17 | Get | Multiplier Link | UINT | 0 |
| 18 | Get | Divisor Link | UINT | 0 |
| 19 | Get | Base Link | UINT | 0 |
| 20 | Get | Offset Link | UINT | 0 |
| 21 | Get | Decimal Precision | USINT | (2) |

¹ Specified in descriptor, data type, and data size.

² Value varies based on parameter instance.

³ Refer to the DeviceNet specification for a description of the connection path.

Common Services

| Service Code | Implemented for | | Service Name |
|--------------|-----------------|----------|----------------------|
| | Class | Instance | |
| 0x01 | Yes | Yes | Get_Attributes_All |
| 0x05 | Yes | No | Reset |
| 0x0E | Yes | Yes | Get_Attribute_Single |
| 0x10 | No | Yes | Set_Attribute_Single |
| 0x4B | No | Yes | Get_Enum_String |

C.8 Class Code 0x10 – Parameter Group Object

Class Attributes

| Attribute ID | Access Rule | Name | Data Type | Value |
|--------------|-------------|-----------------|-----------|-------------|
| 1 | Get | Revision | UINT | 1 |
| 2 | Get | Max Instance | UINT | 3 |
| 8 | Get | Native Language | USINT | 0 = English |

Instance 1 Attributes: Drive Display Instance

| Attribute ID | Access Rule | Name | Data Type | Value |
|--------------|-------------|--------------------------------|--------------|---------------|
| 1 | Get | Group Name String | SHORT_STRING | Drive Display |
| 2 | Get | Number of Members in Group | UINT | 10 |
| 3 | Get | 1st Parameter Number in Group | UINT | 1 |
| 4 | Get | 2nd Parameter Number in Group | UINT | 2 |
| 5 | Get | 3rd Parameter Number in Group | UINT | 3 |
| 6 | Get | 4th Parameter Number in Group | UINT | 4 |
| 7 | Get | 5th Parameter Number in Group | UINT | 5 |
| 8 | Get | 6th Parameter Number in Group | UINT | 6 |
| 9 | Get | 7th Parameter Number in Group | UINT | 7 |
| 10 | Get | 8th Parameter Number in Group | UINT | 8 |
| 11 | Get | 9th Parameter Number in Group | UINT | 9 |
| 12 | Get | 10th Parameter Number in Group | UINT | 10 |

Instance 2 Attributes: Drive Program Instance

| Attribute ID | Access Rule | Name | Data Type | Value |
|--------------|-------------|--------------------------------|--------------|---------------|
| 1 | Get | Group Name String | SHORT_STRING | Drive Program |
| 2 | Get | Number of Members in Group | UINT | 28 |
| 3 | Get | 1st Parameter Number in Group | UINT | 30 |
| 4 | Get | 2nd Parameter Number in Group | UINT | 31 |
| 5 | Get | 3rd Parameter Number in Group | UINT | 32 |
| 6 | Get | 4th Parameter Number in Group | UINT | 33 |
| 7 | Get | 5th Parameter Number in Group | UINT | 34 |
| 8 | Get | 6th Parameter Number in Group | UINT | 35 |
| 9 | Get | 7th Parameter Number in Group | UINT | 36 |
| 10 | Get | 8th Parameter Number in Group | UINT | 37 |
| 11 | Get | 9th Parameter Number in Group | UINT | 38 |
| 12 | Get | 10th Parameter Number in Group | UINT | 39 |
| 13 | Get | 11th Parameter Number in Group | UINT | 40 |
| 14 | Get | 12th Parameter Number in Group | UINT | 41 |
| 15 | Get | 13th Parameter Number in Group | UINT | 42 |
| 16 | Get | 14th Parameter Number in Group | UINT | 43 |
| 17 | Get | 15th Parameter Number in Group | UINT | 44 |
| 18 | Get | 16th Parameter Number in Group | UINT | 45 |
| 19 | Get | 17th Parameter Number in Group | UINT | 46 |
| 20 | Get | 18th Parameter Number in Group | UINT | 47 |
| 21 | Get | 19th Parameter Number in Group | UINT | 48 |
| 22 | Get | 20th Parameter Number in Group | UINT | 49 |
| 23 | Get | 21st Parameter Number in Group | UINT | 50 |
| 24 | Get | 22nd Parameter Number in Group | UINT | 51 |
| 25 | Get | 23rd Parameter Number in Group | UINT | 52 |
| 26 | Get | 24th Parameter Number in Group | UINT | 53 |
| 27 | Get | 25th Parameter Number in Group | UINT | 54 |
| 28 | Get | 26th Parameter Number in Group | UINT | 55 |
| 29 | Get | 27th Parameter Number in Group | UINT | 56 |
| 30 | Get | 28th Parameter Number in Group | UINT | 57 |

Instance 3 Attributes: DNet Config Instance

| Attribute ID | Access Rule | Name | Data Type | Value |
|--------------|-------------|--------------------------------|--------------|-------------|
| 1 | Get | Group Name String | SHORT_STRING | DNet Config |
| 2 | Get | Number of Members in Group | UINT | 13 |
| 3 | Get | 1st Parameter Number in Group | UINT | 101 |
| 4 | Get | 2nd Parameter Number in Group | UINT | 102 |
| 5 | Get | 3rd Parameter Number in Group | UINT | 103 |
| 6 | Get | 4th Parameter Number in Group | UINT | 104 |
| 7 | Get | 5th Parameter Number in Group | UINT | 105 |
| 8 | Get | 6th Parameter Number in Group | UINT | 106 |
| 9 | Get | 7th Parameter Number in Group | UINT | 107 |
| 10 | Get | 8th Parameter Number in Group | UINT | 108 |
| 11 | Get | 9th Parameter Number in Group | UINT | 109 |
| 12 | Get | 10th Parameter Number in Group | UINT | 110 |
| 13 | Get | 11th Parameter Number in Group | UINT | 111 |
| 14 | Get | 12th Parameter Number in Group | UINT | 112 |
| 15 | Get | 13th Parameter Number in Group | UINT | 113 |

Common Services

| Service Code | Implemented for | | Service Name |
|--------------|-----------------|----------|----------------------|
| | Class | Instance | |
| 0x01 | Yes | Yes | Get_Attributes_All |
| 0x0E | Yes | Yes | Get_Attribute_Single |

C.9 Class Code 0x28 – Motor Data Object

Class Attributes

| Attribute ID | Access Rule | Name | Data Type | Value |
|--------------|-------------|-----------------|-----------|-------|
| 1 | Get | Revision | UINT | 1 |
| 2 | Get | Max Instance | UINT | 1 |
| 6 | Get | Max ID Class | UINT | 7 |
| 7 | Get | Max ID Instance | UINT | 15 |

Instance 1 Attributes

| Attribute ID | Access Rule | Name | Data Type | Value |
|--------------|--------------------------|--------------------------------|----------------|---------------------------------------|
| 1 | Get | Number of Attributes | USINT | 12 |
| 2 | Get | Attributes List | Array of USINT | 1, 2, 3, 4, 5, 6, 7, 8, 9, 11, 12, 15 |
| 3 | Get | Motor Type | USINT | 7 = Squirrel Cage Induction Motor |
| 4 | Get | Catalog Number | SHORT_STRING | 1 |
| 5 | Get | Manufacturer | SHORT_STRING | "Reliance Electric" |
| 6 | Get | Rated Current | UINT | 0.1 Amps ¹ |
| 7 | Get | Rated Voltage | UINT | Volts ¹ |
| 8 | Get | Rated Power at Rated Frequency | UDINT | Watts ¹ |
| 9 | Get | Rated Electrical Frequency | UINT | 1 |
| 11 | Get/ Set ² | Maximum Allowed Motor Speed | UINT | 1500 to 3600 RPM |
| 12 | Get | Pole Count | UINT | 4 |
| 15 | Get/ Set | Base Speed | UINT | 300 to 3600 RPM |

¹ Value varies based on drive model.

² This attribute can be set only when the drive is stopped.

Common Services

| Service Code | Implemented for | | Service Name |
|--------------|-----------------|----------|----------------------|
| | Class | Instance | |
| 0x0E | Yes | Yes | Get_Attribute_Single |
| 0x10 | No | Yes | Set_Attribute_Single |

C.10 Class Code 0x29 – Control Supervisor Object

Class Attributes

| Attribute ID | Access Rule | Name | Data Type | Value |
|--------------|-------------|-----------------|-----------|-------|
| 1 | Get | Revision | UINT | 1 |
| 2 | Get | Max Instance | UINT | 1 |
| 6 | Get | Max ID Class | UINT | 7 |
| 7 | Get | Max ID Instance | UINT | 17 |

Instance 1 Attributes

| Attribute ID | Access Rule | Name | Data Type | Value |
|--------------|----------------------|----------------------|----------------|---|
| 1 | Get | Number of Attributes | USINT | 17 |
| 2 | Get | Attributes List | Array of USINT | 1, 2, 3, 4, 5, 6, 7, 8, 9, 10, 11, 12, 13, 14, 15, 16, 17 |
| 3 | Get/Set ¹ | Run 1 | BOOL | See Run/Stop Event Matrix on page C-22. |
| 4 | Get/Set ¹ | Run 2 | BOOL | See Run/Stop Event Matrix on page C-22. |
| 5 | Get/Set ¹ | NetCtrl | BOOL | 0 = TB or keypad control 1 = Network control |
| 6 | Get | State | USINT | 3 = Ready 4 = Enabled 5 = Stopping 7 = Faulted |
| 7 | Get | Running 1 | BOOL | 0 = Not running forward 1 = Running forward |
| 8 | Get | Running 2 | BOOL | 0 = Not running reverse 1 = Running reverse |
| 9 | Get | Ready | BOOL | 0 = Other state 1 = Ready or Enabled or Stopping |
| 10 | Get | Faulted | BOOL | 0 = No faults present 1 = Fault occurred (latched) |
| 11 | Get | Warning | BOOL | 0 |
| 12 | Get/Set | Fault Reset | BOOL | 0 = No action 0 -> 1 = Fault Reset |

¹ This attribute can be set only when the expected packet rate (EPR) for the explicit connection is non-zero and the VSM500 unit does not have an active I/O connection.

| Attribute ID | Access Rule | Name | Data Type | Value |
|------------------|-------------|---------------------|-----------|--|
| 13 | Get | Fault Code | UINT | 0x0000 = No fault 0x1000 = general fault 0x2220 = over current 0x3210 = high bus 0x3220 = low bus (stopped) 0x3221 = low bus (running) 0x4310 = drive overtemp 0x5300 = function loss 0x5301 = tb redundant start 0x6310 = eeprom parameter checksum 0x6311 = devicenet eeprom 0x6312 = eeprom drive id 0x7122 = thermal overload 0x7500 = no devicenet power 0x7501 = devicenet lost i/o connection 0x7502 = devicenet unrecoverable fault 0x7504 = devicenet forced fault 0x7505 = devicenet communication fault 0x7510 = communication loss 0x7700 = keypad disconnected 0x7701 = display fixed pattern 0x7702 = keypad redundant start 0x7703 = keypad connected |
| 14 | Get | Warn Code | UINT | 0 |
| 15 | Get | Ctrl From Net | BOOL | 0 = TB or keypad control 1 = Network control |
| 16 | Get/Set | DNet Fault Mode | USINT | 0 = Fault and Stop 1 = Ignore |
| 17 | Get/Set | Force Fault/Trip | BOOL | 0 -> 1 = Force fault |
| 102 ¹ | Get/Set | DNet Preset Command | USINT | 0 to 7 |
| 103 ¹ | Get/Set | DNet Speed Ref RPM | UINT | 0 to 3600 (RPM) |
| 104 ¹ | Get/Set | DNet Speed Ref Hz | UINT | 0 to 120.0 (0.1 Hz) |

¹ This attribute can be set only when the expected packet rate (EPR) for the explicit connection is non-zero and the VSM500 unit does not have an active I/O connection.

Common Services

| Service Code | Implemented for | | Service Name |
|--------------|-----------------|----------|----------------------|
| | Class | Instance | |
| 0x05 | No | Yes | Reset |
| 0x0E | Yes | Yes | Get_Attribute_Single |
| 0x10 | No | Yes | Set_Attribute_Single |

State Transition Diagram

The following State Transition Diagram provides a graphical description of the states and state transitions that are reflected in attribute #6.

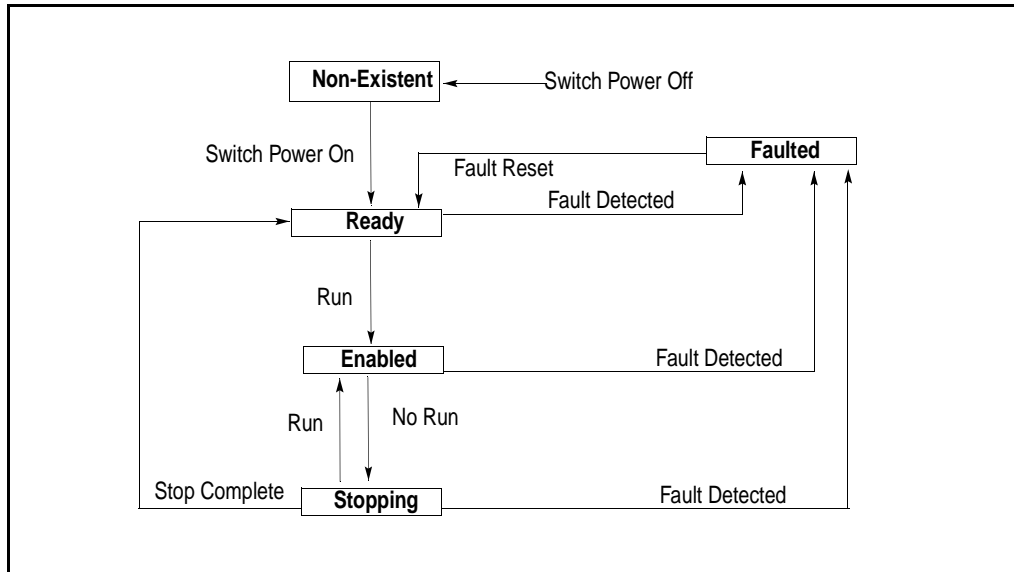

Figure C.1 – State Transition Diagram

Run/Stop Event Matrix

Attribute 5, NetCtrl, is used to request that Run/Stop events be controlled from the network. Before Run/Stop control is accomplished from the network, Attribute 15, CtrlFromNet must be set to 1 by the device in response to a NetCtrl request.

If attribute 15, CtrlFromNet is set to 1, the events Run and Stop are triggered by a combination of the RunFwd and RunRev attributes as shown in the following table.

| RunFwd | RunRev | Trigger Event | Run Type |
|--------|--------|---------------|----------|
| 0 | 0 | Stop | NA |
| 0 -> 1 | 0 | Run | RunFwd |
| 0 | 0 -> 1 | Run | RunRev |
| 0 -> 1 | 0 -> 1 | No Action | NA |
| 1 | 1 | No Action | NA |
| 1->0 | 1 | Run | RunRev |
| 1 | 1->0 | Run | RunFwd |

Important: When attempting to use attribute 3 or 4 to start the drive, the Explicit Message connection (Class 5, instance 1) attribute 9, Expected Packet Rate must be set to greater than zero.

C.11 Class Code 0x2A – AC Drive Object

Class Attributes

| Attribute ID | Access Rule | Name | Data Type | Value |
|--------------|-------------|-----------------|-----------|-------|
| 1 | Get | Revision | UINT | 1 |
| 2 | Get | Max Instance | UINT | 1 |
| 6 | Get | Max ID Class | UINT | 7 |
| 7 | Get | Max ID Instance | UINT | 29 |

Instance 1 Attributes

| Attribute ID | Access Rule | Name | Data Type | Value |
|--------------|-------------|----------------------|----------------|--|
| 1 | Get | Number of Attributes | USINT | 20 |
| 2 | Get | Attributes List | Array of USINT | 1, 2, 3, 4, 6, 7, 8, 9, 10, 16, 17, 18, 19, 20, 21, 22, 23, 27, 28, 29 |
| 3 | Get | At Reference | BOOL | 0 = Drive not running at speed reference 1 = Drive running at speed reference |
| 4 | Get/Set | Net Ref | BOOL | 0 = TB or keypad speed ref 1 = Network speed ref |
| 6 | Get | Drive Mode | USINT | 1 = Open loop speed (frequency) |
| 7 | Get | Speed Actual | INT | 0 to 3600 RPM |
| 8 | Get | Speed Ref | INT | 0 to 3600 RPM |
| 9 | Get | Current Actual | INT | 0.1 Amp ¹ |
| 10 | Get | Current Limit | INT | 0.1 Amp ¹ |
| 16 | Get | Input Voltage | INT | Volts (input line voltage) ¹ |
| 17 | Get | Output Voltage | INT | Volts ¹ |
| 18 | Get/Set | Accel Time | UINT | 500 to 45000 ² |
| 19 | Get/Set | Decel Time | UINT | 500 to 45000 ² |
| 20 | Get/Set | Low Speed Limit | UINT | 0 to 1800 RPM |
| 21 | Get/Set | High Speed Limit | UINT | 1500 to 3600 RPM |
| 22 | Get | Speed Scale | SINT | 0 |
| 23 | Get | Current Scale | SINT | 0 |
| 27 | Get | Voltage Scale | SINT | 0 |
| 28 | Get | Time Scale | SINT | -1 |
| 29 | Get | Ref From Net | BOOL | 0 = TB or keypad speed ref 1 = Network speed ref |

¹ Value varies based on drive rating and operating conditions.

² This value is converted to milliseconds using the following formula: value x 2 = milliseconds. For example, a value of 45000 equals 90.000 seconds.

Common Services

| Service Code | Implemented for | | Service Name |
|--------------|-----------------|----------|----------------------|
| | Class | Instance | |
| 0x0E | Yes | Yes | Get_Attribute_Single |
| 0x10 | No | Yes | Set_Attribute_Single |

C.12 Class Code 0x2B – Acknowledge Handler Object

Class Attributes

| Attribute ID | Access Rule | Name | Data Type | Value |
|--------------|-------------|--------------|-----------|-------|
| 1 | Get | Revision | UINT | 1 |
| 2 | Get | Max Instance | UINT | 1 |

Instance 1 Attributes

| Attribute ID | Access Rule | Name | Data Type | Value |
|--------------|-------------|-----------------------------------|-----------|----------------------------|
| 1 | Get/Set | Acknowledge Timer | UINT | Timer resolution of 8 msec |
| 2 | Get | Retry Limit | USINT | 1 |
| 3 | Get | COS Producing Connection Instance | UINT | 4 |

Common Services

| Service Code | Implemented for | | Service Name |
|--------------|-----------------|----------|----------------------|
| | Class | Instance | |
| 0x0E | Yes | Yes | Get_Attribute_Single |
| 0x10 | No | Yes | Set_Attribute_Single |

Glossary

Assembly Objects: The DeviceNet Specification defines Assembly Objects as objects that “bind attributes of multiple objects to allow data to or from each object to be sent over a single connection.” The VSM500 unit with a DeviceNet option board uses assembly objects to transmit data to and from a scanner over a control I/O connection. The terms “input” and “output” are defined from the scanner’s point of view. Output assemblies are sent by the scanner and consumed by the unit. Input assemblies are sent by the unit and consumed by the scanner.

Bus Off: A bus off condition occurs when an abnormal rate of errors is detected on the Control Area Network (CAN) bus in a device. The bus-off device cannot receive or transmit messages on the network. This condition is often caused by corruption of the network data signals due to noise or data rate mismatch.

Change of State (COS) I/O Data Exchange: A device that is configured for change of state I/O data exchange transmits data only when its data has changed. This type of exchange can reduce network traffic and save resources since old data does not need to be transmitted or processed.

Classes: A device has many objects. Each type of object is grouped in a class that is identified with a unique ID number.

Controller: A controller, also called programmable logic controller and processor, is a solid-state control system that has a user-programmable memory for storage of instructions to implement specific functions such as I/O control, logic, timing, counting, report generation, communication, arithmetic, and data file manipulation. A controller consists of a central processor, input/output interface, and memory. See also Scanner.

Cyclic I/O Data Exchange: A device configured for cyclic I/O data exchange transmits data at a user-configured rate. This type of exchange ensures that data is updated at an appropriate rate for the application, preserves bandwidth for rapidly-changing devices, and allows data to be sampled at precise intervals for better determinism.

Data Rate: The data rate, sometimes called baud rate, is the speed at which data is transferred on the DeviceNet network. The available data rates depend on the type of cable and total cable length used on the network:

| Cable | Maximum Cable Length Based on Data Rate | | |
|------------------------|---|-----------------|-----------------|
| | 125 K | 250 K | 500 K |
| Thick Trunk Line | 500 m (1,640 ft.) | 250 m (820 ft.) | 100 m (328 ft.) |
| Thin Trunk Line | 100 m (328 ft.) | 100 m (328 ft.) | 100 m (328 ft.) |
| Maximum Drop Length | 6 m (20 ft.) | 6 m (20 ft.) | 6 m (20 ft.) |
| Cumulative Drop Length | 156 m (512 ft.) | 78 m (256 ft.) | 39 m (128 ft.) |

Each device on a DeviceNet network must be set for the same data rate. You can set the DeviceNet option board to 125K, 250K, or 500K. You can set it to Autobaud if another device on the network has set the data rate.

DeviceNet Network: A DeviceNet Network is a producer/consumer Control Area Network (CAN) that connects controllers (e.g., PLCs and SLCs) and devices (e.g., drives and motor starters). Both implicit (control I/O) and explicit (configuration) messages can be transmitted over the network. A DeviceNet network can support a maximum of 64 devices. Each device is assigned a unique node address and transmits data on the network at the same data rate.

A cable is used to connect devices on the network. It contains both the signal and power wires. Devices can be connected to the network with drop lines, in a daisy chain connection, or a combination of the two.

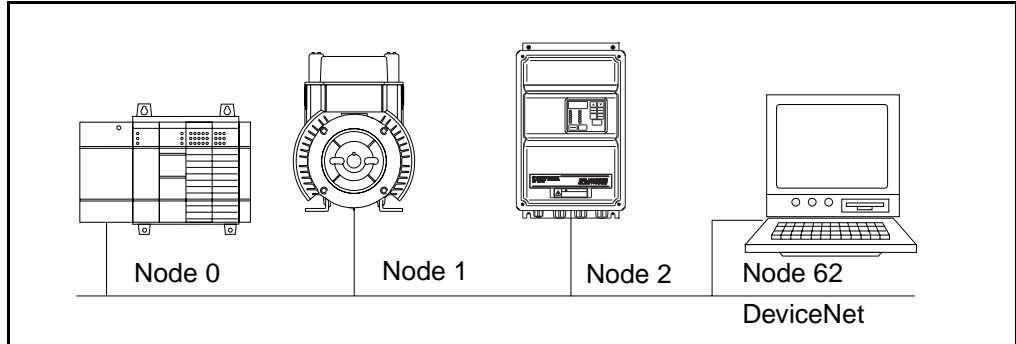

Figure D.1 – Example DeviceNet Network

| Node | Description |
|------|--|
| 0 | SLC Scanner. PLC and SLC scanners connect controllers to the network. |
| 1 | VSM500 Integrated Drive/Motor with a DeviceNet option board. |
| 2 | GV3000 AC drive with a DeviceNet option board.. Many products (including sensors, push buttons, motor starters, simple operator interfaces, and drives) can be connected to a DeviceNet network. |
| 62 | Computer using a 1784-PCD adapter. A computer running software such as DeviceNet Manager can be used to configure the network and devices. |

General information about DeviceNet and the DeviceNet specification are maintained by the Open DeviceNet Vendor's Association (ODVA) at <http://www.odva.org>.

DeviceNet Manager Software: DeviceNet Manager software is a tool for configuring and monitoring DeviceNet networks and connected devices. It is a 16-bit Windows application that runs on Windows™ 95, Windows 98, and Windows NT® (4.0 or greater).

DeviceNet Option Board: Devices such as drives, controllers, and computers usually require an option board to provide a communication interface between them and a network such as DeviceNet. A DeviceNet option board reads data on the network and transmits it to the connected device. It also reads data in the device and transmits it to the network.

Option boards are sometimes also called adapters, cards, gateways, modules, or peripherals.

Electronic Data Sheet (EDS) Files: EDS files are simple text files that are used by network configuration tools, such as DeviceNet Manager and RSNetWorx for DeviceNet, to help you identify products such as VSM500 units and easily commission them on a network. EDS files describe a product device type, revision, and configurable parameters.

Explicit Messaging: Explicit messages are used to configure, monitor, and diagnose devices.

Fault Action: A fault action determines how the option and connected VSM500 unit act when there is a communications fault (e.g., a cable is disconnected).

Faulted Node Recovery: If you have software that supports this feature, you can change a configuration of a device that is faulted on the network. For example, if you add a device to a network and it does not have a unique address, it will fault. If it has faulted node recovery, you can change its node address so that it is no longer faulted.

Hold Last State: When communications are disrupted (e.g., a cable is disconnected), the DeviceNet option board and VSM500 unit can respond by holding last state. Hold last state results in the VSM500 unit receiving the last data received via the DeviceNet connection before the disruption. If the VSM500 unit was in RUN mode and using the reference from DeviceNet, it will continue to run at the same reference.

I/O Messaging: I/O messages are used to transmit time-critical I/O data that controls the drive. I/O messages are sometimes referred to as implicit messages. The I/O messages used for the VSM500 unit depend on the input and output assemblies that you are using.

Idle Action: An idle action determines how the option and connected VSM500 unit act when the processor is placed into an idle mode.

Logic Command/Status: The logic command/status is used to control and monitor the VSM500 unit (e.g., start, stop, direction). The definition and size of the logic command/status depends on which assemblies are being used.

Master/Slave Hierarchy: An VSM500 unit configured for a master-slave hierarchy exchanges data with the master device (scanner). Usually, a network has one scanner which is the master device, and all other devices are slave devices. A network can have multiple scanners. These networks are sometimes referred to as "multimaster hierarchies." On such networks, each slave device must have a scanner specified as its master.

Node Address: A DeviceNet network can have as many as 64 devices connected to it. Each device on the network must have a unique node address between 0 and 63. However, some node addresses are reserved for special devices. For example, node number 0 is usually reserved for scanners. Node number 62 is usually reserved for a computer connected to the network. Node number 63 is always reserved for new devices.

Object: An object consists of the attributes (data), services (functions), and behavior (operations) that are bound together to support a functionality in a device.

Polled I/O Data Exchange: A device that is configured for polled I/O data exchange sends data immediately after it receives data. For example, an option receives a logic status command from the scanner and then sends the logic status of connected VSM500 unit.

Producer/Consumer Network: DeviceNet is a producer/consumer network. On producer/consumer networks, packets are identified by content rather than by an explicit destination. If a node needs the packet, it will accept the identifier and consume the packet. The source therefore sends a packet once and all the nodes consume the same packet if they need it. Data is therefore produced once, regardless of the number of consumers. Also, precise synchronization is possible because data arrives at each node at the same time

Reference/Feedback: The reference/feedback is used to send a reference (i.e., command speed) to the VSM500 unit and monitor its feedback (i.e. actual speed). The size and definition of the reference/feedback depend on the assemblies that you are using.

RSNetWorx for DeviceNet Software: RSNetWorx for DeviceNet software is tool for configuring and monitoring DeviceNet networks and connected devices. It is a 32-bit Windows application that runs on Windows 95, Windows 98, and Windows NT.

Scanner: A scanner is a separate module (of a multi-module controller) or a built-in component (of a single-module controller) that provides communication with options connected to a network. See also Controller.

UCMM (UnConnected Message Manager): UCMM is the use of explicit messages that use the DeviceNet group 3 identifiers. They allow multiple devices to access the VSM500 unit and DeviceNet option board at the same time.

VSM500 Integrated/Drive Motor: The VSM500 Integrated Drive/Motor is an AC drive integrally mounted with an inverter duty motor. It consists of a drive section and a motor section. It may be connected to a DeviceNet network with a DeviceNet option board. In this manual, the VSM500 Integrated Drive/Motor is also referred to as "VSM500 unit," "drive," or "unit."

Zero Data: When communications are disrupted (e.g., a cable is disconnected), the DeviceNet option board and VSM500 unit can respond with zero data. Zero data results in the VSM500 unit receiving zero as values for logic command and speed reference. This will stop the unit.

Numerics

10-pin linear plug, 2-5

A

AC Drive object, C-23

Accel Time parameter, B-4

accessing parameters, 3-4 to 3-5

Acknowledge Handler object, C-24

adapter, *see* DeviceNet option board

Analog Input parameter, B-3

Analog Maximum parameter, B-6

Analog Minimum parameter, B-5

assemblies

definition, D-1

relationship to I/O messaging, 5-1

selecting, 3-7

Assembly object, C-6

Auto Restart Attempts parameter, B-4

Auto Restart Delay parameter, B-4

autobaud, B-7, D-2

B

Base Frequency parameter, B-5

Base Voltage parameter, B-5

baud rate, *see* data rate

bit definitions, C-7, C-9

bus off, D-1

Bus Off Count parameter, B-7

Bus Off Error parameter, B-7

Bus Voltage parameter, B-3

C

cables, 2-5

change of state

definition, D-1

parameter, B-9

setting the mask, 3-10 to 3-11

setting up scan list, 4-2 to 4-5

classes, D-1

COMM status indicator

at first power up, 2-6

locating, 7-1

understanding, 7-2

Command Frequency parameter, B-3

communications fault action, 3-9

communications module, *see* DeviceNet option board

communications specifications, A-1

components, 1-1

configuration tools, 3-1

configuring a scanner, 4-1 to 4-8

configuring the option board, 3-1 to 3-12

connecting the option board to the network, 2-5

connecting the option board to the unit, 2-2

Connection object, C-10

Control Supervisor object, C-20

controllers

definition, D-1

explicit messaging, 6-1 to 6-5

I/O messaging, 5-1 to 5-5

see also scanners

COS Mask parameter, B-9

COS, *see* change of state

cover

installation, 2-5 to 2-6

removal, 2-2

creating EDS files, 3-3 to 3-4

current draw, A-1

cyclic I/O, definition, D-1

D

daisy chain, 2-4

data rate

definition, D-1

parameter, B-7

relation to cable length, D-2

setting with a parameter, 3-6

setting with switches, 2-4

specifications, A-1

Decel Time parameter, B-4

- DeviceNet
 - cables, 2-5
 - definition, D-2
 - example network, D-2
 - objects, C-1 to C-24
- DeviceNet Configuration dialog box, 3-5
- DeviceNet Manager
 - accessing parameters with, 3-4
 - creating EDS files, 3-3
 - definition, D-2
 - going online, 3-1 to 3-2
 - mapping data in a scanner, 4-5 to 4-7
 - saving a configuration, 4-8
 - setting up the scan list, 4-2 to 4-5
- DeviceNet object, C-5
- DeviceNet option board
 - adding to a scan list, 4-2 to 4-5
 - components, 1-1
 - configuring, 3-1 to 3-12
 - definition, D-2
 - features, 1-2
 - installation, 2-1 to 2-6
 - mapping its data in the scanner, 4-5 to 4-7
 - resetting, 3-11 to 3-12
- dimensions, A-1
- DIP switches, 2-3 to 2-4
- DNet Fault Mode parameter, B-8
- DNet Idle Mode parameter, B-8
- DNet SW Version parameter, B-8
- drive, *see* VSM500 Integrated drive/motor
- DriveExplorer, 1-2
- DriveTools32, 1-2
- drop line, 2-5

E

- electrical specifications, A-1
- Electronic Data Sheet (EDS) files
 - creating, 3-3 to 3-4
 - definition, D-3
 - product codes, B-1
- EMC Directive 89/336/EEC, 2-1
- environmental specifications, A-1
- equipment
 - included with option board, 1-2
 - user must supply, 1-2
- examples
 - explicit messaging, 6-3 to 6-4
 - I/O messaging, 5-2
 - network, 4-1

- explicit messaging
 - definition, D-3
 - example, 6-3 to 6-4
 - format, 6-2
 - requirements, 6-1
 - steps to use, 6-1

F

- fault action, D-3
 - parameter, B-8
 - selecting, 3-9
- fault and stop, 3-9
- fault codes, 7-3 to 7-4
- Fault Reset parameter, B-6
- faulted node recovery, 1-2, D-3
- features, 1-2
- format of explicit messages, 6-2

G

- going online, 3-2
- groups of parameters, B-2

H

- hold last state
 - definition, D-3
 - selecting, 3-10 to 3-11

I

- I/O messaging
 - definition, D-4
 - example, 5-2
 - mapping data in scanner, 4-5 to 4-7
 - relationship to assemblies, 5-1
- Identity object, C-2
- idle action
 - definition, D-3
 - selecting, 3-11
- ignore fault, 3-9
- implicit messaging, *see* I/O messaging
- input assemblies
 - bit definitions, C-9
 - definition, D-1
 - parameter, B-8
 - selecting, 3-7
- Input Assembly parameter, B-8

input I/O
 illustrated example, 5-2
 mapping in the scanner, 4-6
Input Status parameter, B-3
installation
 applying power, 2-6
 commissioning the unit for DeviceNet, 2-3 to 2-4
 connecting the cover, 2-5 to 2-6
 connecting the option board to the unit, 2-2
 connecting to the network, 2-5
 DeviceNet option board, 2-1 to 2-6
 EMC Directive 89/336/EEC, 2-1
 Low Voltage Directive 73/23/EEC, 2-1
 preparing, 2-1
IR compensation parameter, B-5

L

ladder logic programs
 example for explicit messaging, 6-3 to 6-5
 example for I/O, 5-3
Last Fault parameter, B-3
LEDs, *see* status indicators
list of parameters, B-3 to B-9
Load Current parameter, B-3
logic command/status
 definition, D-3
 enabling, 3-7 to 3-8
Low Voltage Directive 73/23/EEC, 2-1

M

MAC ID, *see* node address
mapping the unit's data in the scanner, 4-5 to 4-8
mask for change of state, 3-10 to 3-11
master/slave hierarchy, D-3
Maximum Frequency parameter, B-4
mechanical specifications, A-1
Message Router object, C-4
messages
 explicit, 6-1
 I/O, 5-1
 types, C-1
Minimum Frequency parameter, B-4
Motor Data object, C-19
motor, *see* VSM500 Integrated drive/motor
mounting the option board, 2-2 to 2-3

N

network control, 3-7 to 3-8
network reference, 3-8
Network Who window 3-4
node address
 definition D-3
 parameter, B-6
 setting with a parameter, 3-5 to 3-6
 setting with switches, 2-3 to 2-4
NV Baud Rate parameter, B-7
NV MAC ID parameter, B-7

O

objects
 definition, D-3
 list, C-1 to C-24
option board, *see* DeviceNet option board
output assemblies
 bit definitions, C-7 to C-8
 definition, D-1
 parameter, B-7
 selecting, 3-7
Output Assembly parameter, B-7
Output Current parameter, B-3
Output Frequency parameter, B-3
output I/O
 illustrated example, 5-2
 mapping in the scanner, 4-7
Output Voltage parameter, B-3

P

Parameter Group object, C-16 to C-18
Parameter object, C-14 to C-15
parameters
 accessing, 3-4
 groups, B-2
 numeric list, B-3 to B-9
 setting DIP switch 10 to enable, 2-3
 specific name, *see* name
PCCC, 1-2
polled I/O
 definition, D-3
 setting up scan list, 4-2 to 4-5
Power Unit Temperature parameter, B-3
Preset Speed 1 - 7 parameters, B-6
processors, *see* controllers
producer/consumer networks, D-4
product codes, B-1
programmable logic controllers, *see* controllers

protocol, A-1

Q

quick start, 1-4

R

reference/feedback

definition, D-4

enabling, 3-8

Relay Control parameter, B-4

Reset parameter, B-9

resetting the option board, 3-11 to 3-12

Reverse Disable parameter, B-5

RSNetWorx for DeviceNet, D-4

Run On Power Up parameter, B-4

S

saving the configuration, 4-8

scan list, 4-2 to 4-5

scanner

configuring, 4-1–4-8

definition, D-4

explicit messaging, 6-1

ladder logic program, 5-3, 6-3 to 6-5

mapping data in, 4-5 to 4-7

setting up a scan list, 4-2 to 4-5

Slip Compensation parameter, B-5

specifications

communications, A-1

electrical, A-1

environmental, A-1

mechanical, A-1

speed reference, *see* reference/feedback

Start Source parameter, B-4

status indicators

locating, 7-1

understanding, 7-2

Stop Select parameter, B-5

switches, 2-3, 2-4

Switches Baud parameter, B-6

Switches MAC ID parameter, B-6

T

Torque Boost parameter, B-5

Torque Curve parameter, B-5

troubleshooting

COM status indicator, 7-2

fault codes, 7-3 to 7-4

potential problems, 7-5

types of messages, C-1

U

UCMM (UnConnected Message Manager)

definition, D-4

supported, 1-2

unit cable, 1-1, 2-2

unit, *see* VSM500 Integrated drive/motor

V

VSM500 Integrated drive/motor

definition, D-4

groups of parameters, B-2

mapping its data in the scanner, 4-5 to 4-7

parameter list, B-3 to B-9

W

wiring, 2-4

Z

zero data

definition, D-4

selecting, 3-10

U.S. Drives Technical Support

Tel: (1) 262.512.8176, Fax: (1) 262.512.2222, Email: support@drives.ra.rockwell.com, Online: www.ab.com/support/abdrives

www.rockwellautomation.com

Power, Control and Information Solutions Headquarters

Americas: Rockwell Automation, 1201 South Second Street, Milwaukee, WI 53204-2496 USA, Tel: (1) 414.382.2000, Fax: (1) 414.382.4444

Europe/Middle East/Africa: Rockwell Automation, Vorstlaan/Boulevard du Souverain 36, 1170 Brussels, Belgium, Tel: (32) 2 663 0600, Fax: (32) 2 663 0640

Asia Pacific: Rockwell Automation, Level 14, Core F, Cyberport 3, 100 Cyberport Road, Hong Kong, Tel: (852) 2887 4788, Fax: (852) 2508 1846