

Modular Protection System for Motors

Catalog Number 825-P



Important User Information

Because of the variety of uses for the products described in this publication, those responsible for the application and use of this control equipment must satisfy themselves that all necessary steps have been taken to assure that each application and use meets all performance and safety requirements, including any applicable laws, regulations, codes and standards.

The illustrations, charts, sample programs and layout examples shown in this guide are intended solely for purposes of example. Since there are many variables and requirements associated with any particular installation, Rockwell Automation does not assume responsibility or liability (to include intellectual property liability) for actual use based upon the examples shown in this publication.

Rockwell Automation publication SGI-1.1, Safety Guidelines for the Application, Installation and Maintenance of Solid-State Control (available from your local Allen-Bradley distributor), describes some important differences between solid-state equipment and electromechanical devices that should be taken into consideration when applying products such as those described in this publication.

Reproduction of the contents of this copyrighted publication, in whole or part, without written permission of Rockwell Automation, is prohibited.

Throughout this manual we use notes to make you aware of safety considerations:



WARNING: Identifies information about practices or circumstances that can cause an explosion in a hazardous environment, which may lead to personal injury or death, property damage, or economic loss.



ATTENTION: Identifies information about practices or circumstances that can lead to personal injury or death, property damage, or economic loss. Attentions help you identify a hazard, avoid a hazard, and recognize the consequence.



SHOCK HAZARD: Labels may be on or inside the equipment, for example, a drive or motor, to alert people that dangerous voltage may be present.



BURN HAZARD: Labels may be on or inside the equipment, for example, a drive or motor, to alert people that surfaces may reach dangerous temperatures.

IMPORTANT

Identifies information that is critical for successful application and understanding of the product.

European Communities (EC) Directive Compliance

If this product has the CE mark it is approved for installation within the European Union and European Economic Area (EEA). It has been designed and tested to meet the following directives.

EMC Directives

This product is tested to meet the Council Directive 89/336/EEC Electromagnetic Compatibility (EMC) by applying the following standards, in whole:

- EN 60947-4-1 — Low-Voltage Switchgear and Controlgear: Part 4: Contactors and Motor Starters - Section 1: Electromechanical Contactors and Motor Starters
- EN 60947-5-1 — Low-Voltage Switchgear and Controlgear: Part 5: Control Circuit Devices and Switching Elements - Section 1: Electromechanical Control Circuit Devices

This product is intended for use in an industrial environment.

Low Voltage Directive

This product is tested to meet Council Directive 73/23/EEC Low Voltage as amended by 93/68/EEC by applying the safety requirements of EN 60947-4-1 and EN 60947-5-1. For specific information required by EN 60947-4-1 and EN 60947-5-1, see the appropriate sections in this publication.

Notice

This product has been designed for environment A. Use of this product in environment B can cause unwanted electromagnetic disturbances in which case the user could be required to take adequate mitigation measures.



	Important User Information	2
	European Communities (EC) Directive Compliance	3
	EMC Directives	3
	Low Voltage Directive	3
Preface	Manual Overview	11
	Conventions	12
	Chapter 1	
Introduction	Overview	13
	Features	13
	Options and Accessories	14
	Applications	15
	Chapter 2	
Installation	Relay Placement	17
	Physical Location	17
	Relay Mounting	17
	Rear-Panel Connections	18
	Rear-Panel Diagram	18
	Top-Panel Diagram	19
	Power Connections	19
	I/O Diagram	20
	AC/Control Connection Diagrams	21
	Fail-Safe/Non-Fail-Safe Tripping	21
	Converter Module Connection	23
	Core Balance Current Transformer Connections	24
	Voltage Connections	25
	Full-Voltage Non-Reversing Starter	26
	Full-Voltage Reversing Starter	28
	Star-Delta Starting	28
	Two-Speed Motor	30
	Field Serviceability	31
	Fuse Replacement	32
	Real-Time Clock Battery Replacement	32
	Chapter 3	
Front Panel Operation	Front Panel Layout	33
	Normal Front Panel Display	33
	Front Panel Automatic Messages	34
	Front Panel Menus and Operations	35
	Front Panel Security	37
	Front Panel Main Menu	40
	View or Change Settings Using the Front Panel	41
	Setting Entry Error Messages	43

Hardware Commissioning	Chapter 4		
		Connecting a Converter Module (MCM).....	45
		Adding an Optional I/O Card	47
		Adding the Optional Voltage Card.....	48
		Adding the Optional Communication Card.....	49
	Removing an Option Card.....	50	
Using MPS Explorer	Chapter 5		
		Software Overview	51
		Communications Settings.....	51
		Connection/Access Level.....	52
		Data Management.....	52
		Save/Open Configuration Files.....	53
		Button Summary	53
		ANA (Test Analog Output).....	54
		MOT (Motor Operating Statistics)	54
		SER (Serialized Events Recording)	55
		STA (Relay Status)	55
		SUM (Events Summary Report)	56
		MET (Instantaneous Metering) RTD (RTD/Thermal Metering).....	57
		TAR (Display Target Words)	58
		Data Visualization/Trending.....	59
		Validate Settings	61
		I/O Mapping	62
		Resetting/Restoring.....	63
		Troubleshooting	63
	Configuring Protection & Logic Functions	Chapter 6	
			Overview
		Application Data.....	66
		Main Settings	66
		Identifier Settings	66
		Phase Rotation, Nominal Frequency Settings	67
		Date Format	67
		Current Transformer (CT) Configuration, Full Load Current Settings	68
		Voltage Transformer (VT) Configuration Settings	69
		Basic Motor Protection	69
		Overload (Thermal Model)	70
		Short Circuit.....	74
		Ground Fault	75
		Jam	77
		Undercurrent (Load Loss)	77

Current Imbalance/ Phase Loss	78
Protection Disable	79
Start Monitoring	79
Star-Delta (Wye-Delta) Starting	80
Start Inhibit	81
Phase Reversal Protection	81
Speed Switch (Stalling During Start)	82
Thermistor (PTC) Monitoring	82
RTD-Based Protection	83
Voltage-Based Protection	86
Undervoltage	86
Overvoltage	87
VAR Function	87
Underpower	88
Power Factor	88
Frequency	89
Load Control Function	89
I/O Configuration	90
Analog Output	90
Trip Inhibit (Block)	91
Output Relay Behavior	92
Timer Function	93
Front Panel Settings	93
Display Enable	94
I/O Assignments	95
Logic Explanation	100
Stop/Trip Logic	100
Initiate Trip	100
Unlatch Trip	100
Start & Emergency Restart Logic	101
Overload Curves	103

Chapter 7

Metering & Monitoring

Overview	105
Metering	105
Instantaneous Metering	106
Thermal Metering	106
Power Measurement Conventions	107
Motor Operating Statistics	108

Chapter 8

Analyzing Events

Overview	109
Event Summary Reports	109
Serialized Events Recording (SER) Report	110

	SER Triggering.....	110	
	Example Reports	111	
	Chapter 9		
825-PDN DeviceNet Communication Card	Introduction.....	113	
	Features	115	
	Required Equipment	116	
	Equipment Shipping with the Card	116	
	User-Supplied Equipment.....	116	
	Wiring	116	
	Node Commissioning	117	
	Setting the Hardware Switches	118	
	Using RSNetWorx for DeviceNet	119	
	Explicit Messaging.....	121	
	Setting Up the MSG instruction.....	122	
DeviceLogix	124		
DeviceLogix Programming Example.....	125		
Parameter Groups.....	129		
	Chapter 10		
Modbus RTU Communications	Overview	131	
	Installation	131	
	Mounting.....	131	
	Wiring	132	
	Commissioning.....	134	
	Modbus Queries	135	
	Modbus Responses	135	
	Supported Modbus Function Codes	135	
	Modbus Exception Responses	136	
	Cyclical Redundancy Check.....	136	
	03h Read Holding Register Command.....	136	
	06h Preset Single Register Command	137	
	10h Preset Multiple Registers Command.....	138	
	60h Read Parameter Information Command	139	
	61h Read Parameter Text Command	141	
	62h Read Enumeration Text Command	142	
	7Dh Encapsulated Packet With Control Command	143	
	7Eh NOP Command.....	144	
	Modbus Password Control and Parameter Modification.....	144	
	Modbus Serialized Events Recording Register Operation	145	
	Modbus Load Profile Register Operation.....	145	
		Chapter 11	
	Testing & Troubleshooting	Overview	147
Testing.....		147	
Commissioning Tests.....		147	

	Selected Functional Tests	151
	Periodic Tests (Routine Maintenance)	155
	Troubleshooting	157
	Field Serviceability	158
	Power Supply Fuse Replacement	158
	Real-Time Clock (RTC) Battery Replacement	159
	Troubleshooting DeviceNet	160
	Troubleshooting Device Backplane Communication	160
	Chapter 12	
ASCII Serial Communications	Overview	161
	ASCII Serial Port Operation	161
	Introduction	161
	Required Equipment	161
	Connect Your PC to the Relay	162
	Configure Your Terminal Emulation Software	163
	Serial Port Settings	163
	Using Terminal Commands	164
	Serial Port Access Levels	165
	Command Summary	166
	Description of Commands	167
	ACC and 2AC (Level 1 or 2)	167
	ANALOG (Level 2)	167
	DATE (Level 1 or 2)	167
	METER (Level 1 or 2)	168
	MOTOR (Level 1 or 2)	170
	PASSWORD (Level 1 or 2)	170
	QUIT (Level 1 or 2)	171
	SER (Level 1 or 2)	171
	SET (Level 2)	172
	SHOW	173
	STATUS (Level 1 or 2)	174
	STOP (Level 2)	177
	STR (Level 2)	177
	SUMMARY (Level 1 or 2)	177
	TARGET (Level 1 or 2)	178
	TIME (Level 1 or 2)	179
	View or Change Settings with Front Panel Serial Port	179
	Chapter 13	
Firmware Upgrade Instructions	Overview	183
	Required Equipment	183
	Upgrade Instructions	183
	Appendix A	
Specifications	Electrical Ratings	187

	Main Circuits	187
	Control Circuits	188
	Mechanical Ratings.....	189
	RTD Scanner Module	189
	Electromagnetic Compatibility.....	190
	Metering Accuracy	190
	Standards.....	190
	Processing	190
	Primary Current Transformers	191
	825-CBCT Core Balance Current Transformer	191
	DeviceNet Communication Card	192
	 Appendix B	
Parameter List	Overview	193
	 Appendix C	
Relay Word Bits	Overview	235
	Definitions	235
	 Appendix D	
ASCII Port Relay Command Summary	ASCII Port Relay	239
	 Appendix E	
DeviceNet Information	Electronic Data Sheets.....	242
	Product Codes.....	242
	DeviceNet Objects	242
	Identity Object - CLASS CODE 0x0001.....	243
	Message Router - CLASS CODE 0x0002	244
	DeviceNet Object - CLASS CODE 0x0003	244
	Assembly Object - CLASS CODE 0x0004	245
	Custom Parameter Based Input (Produced) Assembly Instance 100	246
	Standard Input (Produced) Assemblies.....	247
	Standard Output (Consumed) Assemblies	250
	Connection Object - CLASS CODE 0x0005	251
	Discreet Input Point Object - CLASS CODE 0x0008.....	254
	Discreet Output Point Object - CLASS CODE 0x0009	255
	Discrete Output Point Object Special Requirements	256
	Parameter Object - CLASS CODE 0x000F	257
	Parameter Object - CLASS CODE 0x0010.....	258
	Discrete Output Group Object - CLASS CODE 0x001E.....	259
	Control Supervisor Object - CLASS CODE 0x0029	261
	Acknowledge Handler Object - CLASS CODE 0x002b	261
	Overload Object - CLASS CODE 0x002c.....	262
	DeviceNet Interface Object - CLASS CODE 0x00B4.....	262

Manual Overview

The 825-P Modular Protection System User Manual describes common aspects of motor relay application and use. It includes the necessary information to install, set, test, and operate the relay and more detailed information about settings and commands. The chapter descriptions are as follows:

- **Preface**
Describes the manual organization and conventions used to present information.
- **Chapter 1: Introduction**
Describes the basic features and functions of the 825-P.
- **Chapter 2: Installation**
Describes how to mount and wire the 825-P; illustrates wiring connections for various applications.
- **Chapter 3: Front Panel Operation**
Explains features and use of the front panel, including front-panel command menu, default displays, and automatic messages.
- **Chapter 4: Hardware Commissioning**
Describes how to install and commission the various hardware options for the 825-P.
- **Chapter 5: Using MPS Explorer**
Describes how to use MPS Explorer software to read diagnostic information and configure the 825-P.
- **Chapter 6: Configuring Protection & Logic Functions**
Describes the operating characteristic of each protection element and explains how to calculate their settings; describes contact output logic.
- **Chapter 7: Metering & Monitoring**
Describes the operation of each metering function; describes the monitoring functions.
- **Chapter 8: Analyzing Events**
Describes front-panel LED operation, trip-type front-panel messages, event summary data, standard event reports, and Serialized Events Recording (SER) report.
- **Chapter 9: 825-PDN DeviceNet Communication Card**
Describes the communication features supported by the 825-P DeviceNet option card.
- **Chapter 10: Modbus RTU Communications**
This chapter describes the communications features supported by the 825-P Modbus RTU Option Card.
- **Chapter 11: Testing & Troubleshooting**
Describes protection element test procedures, relay self-test, and relay troubleshooting.
- **Chapter 12: ASCII Serial Communications**
Describes the serial port commands supported by the 825-P.
- **Chapter 13: Firmware Upgrade Instructions**
Describes the process to upgrade the firmware for the 825-P.

- **Appendix A: Specifications**
Provides detailed specification and certification information for all components of the 825-P Modular Protection System.
- **Appendix B: Parameter List**
Describes the available parameters for the 825-P.
- **Appendix C: Relay Word Bits**
Lists and describes the Relay Word bits (e.g., real-time status of relay I/O, protection functions).
- **Appendix D: ASCII Port Relay Command Summary**
Briefly describes the serial port commands that are fully described in Chapter 12: ASCII Serial Communications.
- **Appendix E: DeviceNet Information**
Describes the details of the features supported by the 825-P DeviceNet option card.

Conventions

Typographic Conventions

The primary ways to configure the 825-P are by using:

- MPS Explorer configuration and monitoring software.
- a command line interface on a PC terminal emulation window, such as Microsoft® HyperTerminal.
- the front-panel menus and push buttons.

Examples

This instruction manual uses several example illustrations and instructions to explain how to effectively operate the 825-P. These examples are for demonstration purposes only. The firmware identification information or settings values included in these examples may not necessarily match those in the current version of your 825-P.

Example Description

STATUS Commands typed at a command line interface on a PC.

Enter Single keystroke on a PC keyboard.

Ctrl+D Multiple/combo combination keystroke on a PC keyboard.

Start > Settings PC dialog boxes and menu selections.

The ">" character indicates submenus.

CLOSE Relay front-panel push buttons.

ENABLE Relay front-panel or rear-panel labels.

MAIN > METER Relay front-panel LCD menus and relay responses.

The ">" character indicates submenus.

Introduction

Overview

The 825-P Motor Relay is designed to protect three-phase motors. The basic relay provides locked rotor, overload, unbalance, and short circuit protection. Voltage-based and RTD-based protection is available as an option. All relay models provide monitoring functions.

This manual contains the information for installing, setting, testing, operating, and maintaining an 825-P. It is not necessary to review the entire manual to perform specific tasks.

A Quick Start Guide, Publication 825-QS001, is also available. It will help to step the first-time user through the device commissioning process.

Features

Standard Protection Features

- Thermal Overload (thermal model)
- PTC (positive temperature coefficient) Overtemperature
- Undercurrent (Load Loss)
- Current Imbalance and Phase Loss
- Overcurrent (Load Jam)
- Short Circuit
- Ground Fault (Residual)
- Ground Fault (Zero Sequence)
- Motor Starting/Running
 - Protection Inhibit During Start
 - Start Motor Timer
 - Notching or Jogging Device
 - TCU (Thermal Capacity Utilization) Start Inhibit
 - Anti-Backspin Timer
 - Emergency Start
 - Two Speed Protection
 - Reduced Voltage Starting (Star-Delta)
 - Stall-Speed Switch
- Frequency

Optional Protection Features

Voltage-Based Protection

- Undervoltage
- Overvoltage
- Underpower
- Reactive Overpower
- Phase Reversal
- Power Factor

RTD-Based Protection

Up to 12 RTDs can be monitored when an external 825-PR12D RTD Scanner is used. There are separate trip and warn settings for each RTD.

Monitoring Features

The monitoring features of the 825-P are as follows:

- Event summaries contain relay ID, date and time, trip cause, and current/voltage magnitudes.
- Serialized Events Recording (SER).
- Motor running time since the last reset.
- Start cycles since the last reset.
- Emergency start cycles since the last reset.
- A complete suite of accurate metering functions.

Options and Accessories

Options

- The 825-P has the following options:
 - Voltage Option: four-wire wye or open-delta connected potential transformers
 - Input/Output (I/O) Option: one 4...20 mA analog (transducer) output, three additional control inputs, and four additional contact outputs
 - Network communications options
 - DeviceNet
 - Modbus

Accessories

Phase current inputs require one of the following external 825-MCM converter modules:

Table 1 - Converter Module List

Description	Cat. No.
0.5...2.5 A Converter Module	825-MCM2
1.0...5.0 A Converter Module	825-MCM5
2.5...20 A Converter Module	825-MCM20
20...180 A Converter Module	825-MCM180
160...630 A Converter Module	825-MCM630
160...630 A Converter Module	825-MCM630N

The ground fault current (zero sequence) feature requires an external 825-CBCT Core Balance Current Transformer, or equivalent.

The following devices are required to add RTD protection:

- An external RTD scanner Cat. No. 825-PR12D RTD. A fiber-optic cable is not included with the 825-PR12D).
- A simplex 62.5/125 μm fiber-optic cable with ST connector for connecting the external RTD scanner to the 825-P (e.g., part# 1570FCBL-MM-SX-62-STST-2M from Ultra Spec Cable - <http://store.ultraspec.us>).

Applications

The 825-P can be used with the following across the line starter applications:

- Low and medium voltage with 2 or 3 potential transformers
- With or without phase current transformers
- With or without zero-sequence core balance current transformer
- With or without external RTD module
- Reversing starter
- Star-delta starting
- Two-speed motors

Figure 1 shows “across the line starting” AC connections for the case where external current transformers are not required. Refer to Chapter 2: Installation for additional applications and the related connection diagrams.

Figure 1 - AC Connections Without CTs

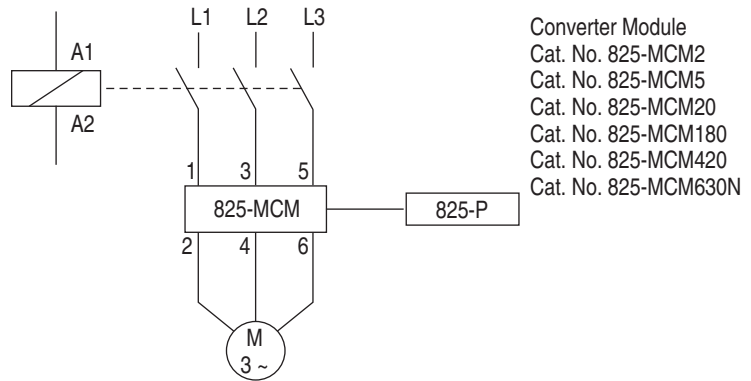

Installation

Relay Placement

Proper placement of the 825-P Motor Relay helps make certain that you receive years of trouble-free motor protection. Use the following guidelines for proper physical installation of the 825-P.

Physical Location

You can mount the 825-P in a sheltered indoor environment (a building or an enclosed cabinet) that does not exceed the temperature and humidity ratings for the relay. The relay can be mounted indoors or in an outdoor (extended) enclosure where the relay is protected against exposure to direct sunlight, precipitation, and full wind pressure, but neither temperature nor humidity are controlled.

Refer to Appendix:A Specifications for environmental ratings.

Relay Mounting

To flush mount the 825-P in a panel, cut a rectangular hole with the dimensions shown in Figure 2.

Figure 2 - Relay Mounted In a Panel

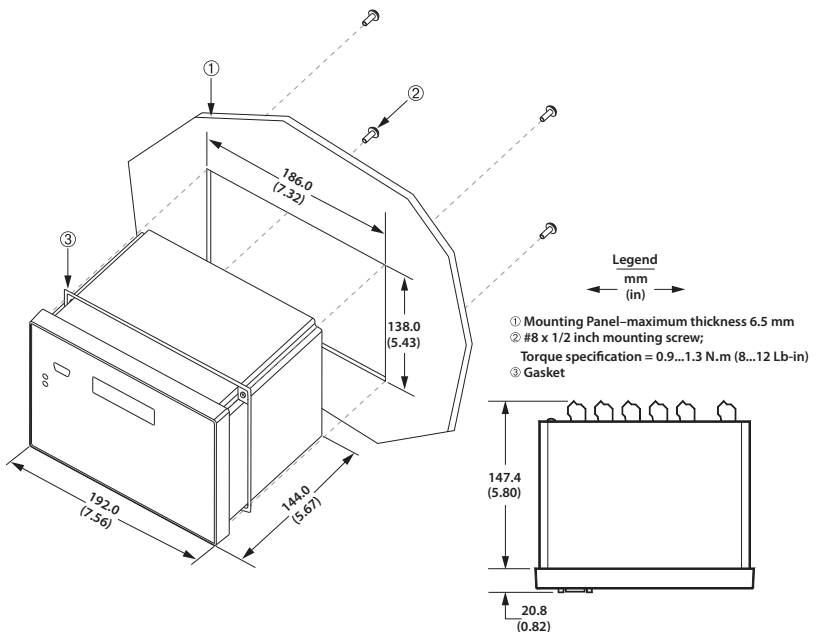

Rear-Panel Connections

Rear-Panel Diagram

The physical layout of the connectors on the rear-panel of a fully configured 825-P is shown in Figure 3.

Figure 3 - Rear-Panel Layout

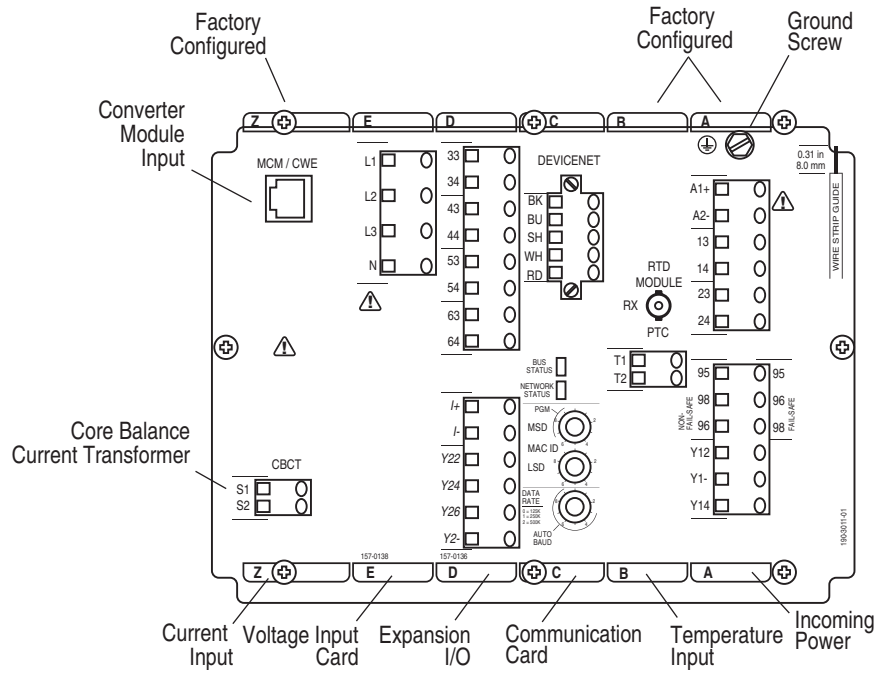

Top-Panel Diagram

The input and output designations for the rear-panel connectors of a fully configured 825-P are shown in Figure 4. This diagram is located on the top panel of the relay.

Figure 4 - Top-Panel Input and Output Designations

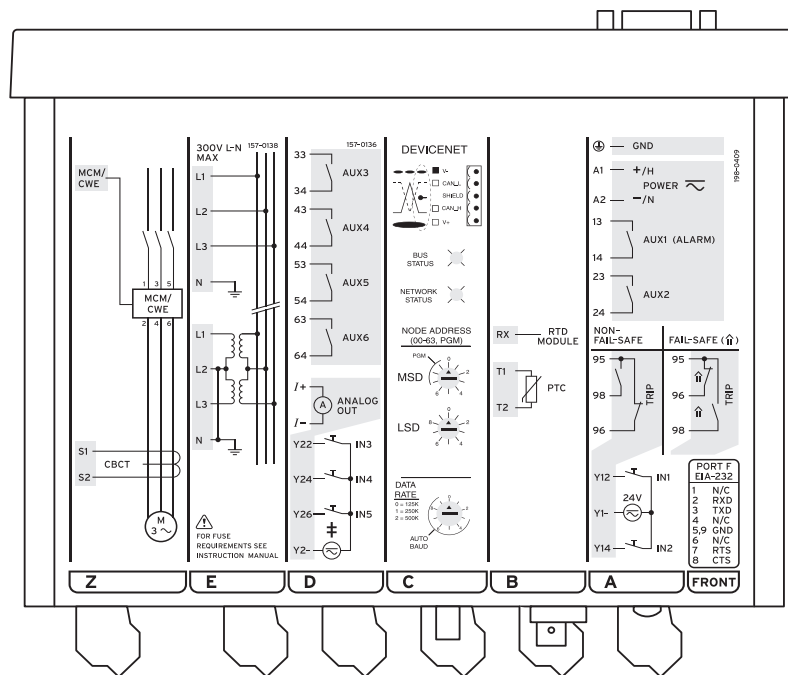

‡ See documentation for input voltage rating.

Power Connections

The power terminals on the rear panel (A1+ and A2-) must connect to 110...240V AC or 110...250V DC for the 825-PD and 24...48V DC for the 825-PZ. For complete power input specifications, see Appendix: A Specifications.

The power terminals are isolated from the chassis ground. Use 16 AWG (1.5 mm²) size or heavier wire to connect to the POWER terminals. Connection to external power must comply with IEC 947-1 and IEC 947-3. Place an external switch, circuit breaker, or overcurrent device in the power leads for the 825-P; this device must interrupt both the positive (A1+) and neutral (A2-) power leads. The maximum current rating for the power disconnect circuit breaker or overcurrent device (fuse) must be 20 A. Be sure to locate this device within 3.0 m (9.8 ft.) of the relay.

Operational power is internally fused by power supply fuse. See Field Serviceability on page 31 for details. Be sure to use fuses that comply with IEC 127-2.

I/O Diagram

A more functional representation of the control (I/O) connections are shown in Figure 5.

Figure 5 - Control I/O Connections in Powered-Down State

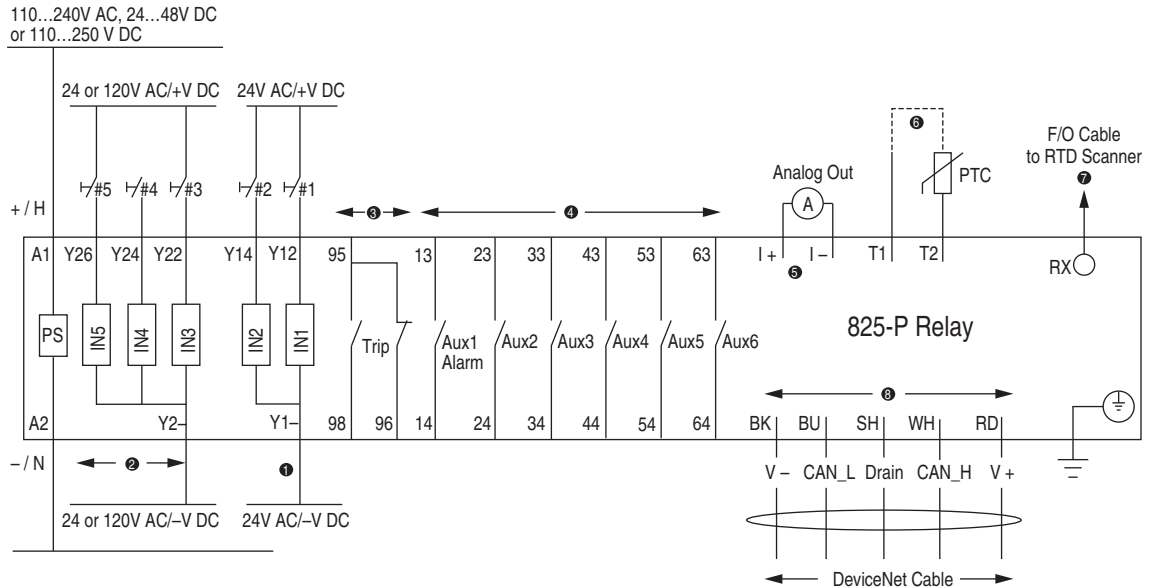

- ❶ See Table 44 for control function assignment to the input IN1 and IN2. Connect the appropriate external contacts (#1 and #2) to the inputs.
- ❷ Inputs IN3, IN4, and IN5 are available when an optional I/O extension card is present. 825-PIOD inputs are rated 120V AC/DC. 825-PIOR inputs are rated 24V AC/DC.
- ❸ See Table 42 for mapping protection elements to the Trip output. See Figure 7 and Figure 16 for typical control circuit connections.
- ❹ See Table 43 for mapping protection and/or control elements to the Aux outputs. Outputs Aux3 through Aux6 are available when an optional I/O extension card is present.
- ❺ Analog Output is available when an optional I/O extension card is present.
- ❻ You can connect up to six thermistors (PTC) in series. See Table 2 for PTC cable requirements.
- ❼ Use up to 500 meter long Simplex 62.5/125 mm fiber-optic cable (ST/ST).
- ❽ Available when an optional DeviceNet Communications Protocol Card is present.

Table 2 shows the maximum cable lengths for the PTC connections.

Table 2 - PTC Cable Requirements

Wire Size, Twisted Pair, AWG No.	Maximum Length (meters) Shielded Cable	Maximum Length (meters) Unshielded Cable
20	200	100
18	300	100
17	400	100
16	600	100
14	1000	100

AC/Control Connection Diagrams

This section describes fail-safe versus non-fail-safe tripping, describes voltage connections, and provides the AC and DC wiring diagrams for the following applications:

- Across the line starting
- Star-delta starting
- Two-speed motor

Fail-Safe/Non-Fail-Safe Tripping

The Trip relay can be configured for Fail-Safe or Non-Fail-Safe operation by way of the Relay Behavior settings group discussed in Output Relay Behavior on page 92. The Trip relay output is a Form C contact consisting of a common terminal, a normally open (N.O.) terminal and a normally closed (N.C.) terminal. The terminals require different contact designations based on whether the Trip relay is configured for Fail-Safe or Non-Fail-Safe operation.

The proper contact designations for Fail-Safe and Non-Fail-Safe configurations are identified in Figure 6. Be certain to apply the appropriate marking strip to the terminal plug corresponding to the configuration of the relay's trip output.

The 825-P provides fail-safe and non-fail-safe trip modes (setting selectable) for the Trip and Aux (auxiliary) contacts. The following occurs in fail-safe mode:

- The Trip relay coil is energized continuously.
- When the 825-P generates a trip signal, the Trip relay coil is de-energized.
- The Trip relay coil is also de-energized if the 825-P input power is removed or if the 825-P fails (self-test status is FAIL).

Figure 6 - TRIP Relay Output Contact Configurations

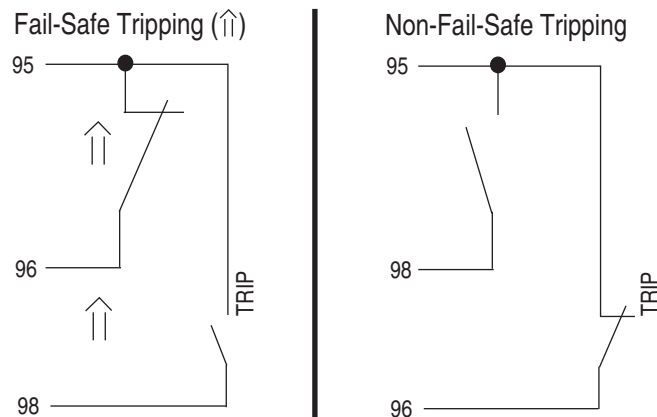

NOTE: Contact numbering changes are based on the TRIP Fail-Safe Setting.

Figure 7 shows fail-safe and non-fail-safe wiring methods to control breakers and contactors. Keep in mind that the “Fail-Safe (Electrically Held)” and “Non-Fail-Safe” labels apply to the whole row that they are aligned with and not just to the single diagram that they are next to.

Figure 7 - TRIP Contact Fail-Safe and Non-Fail-Safe Options

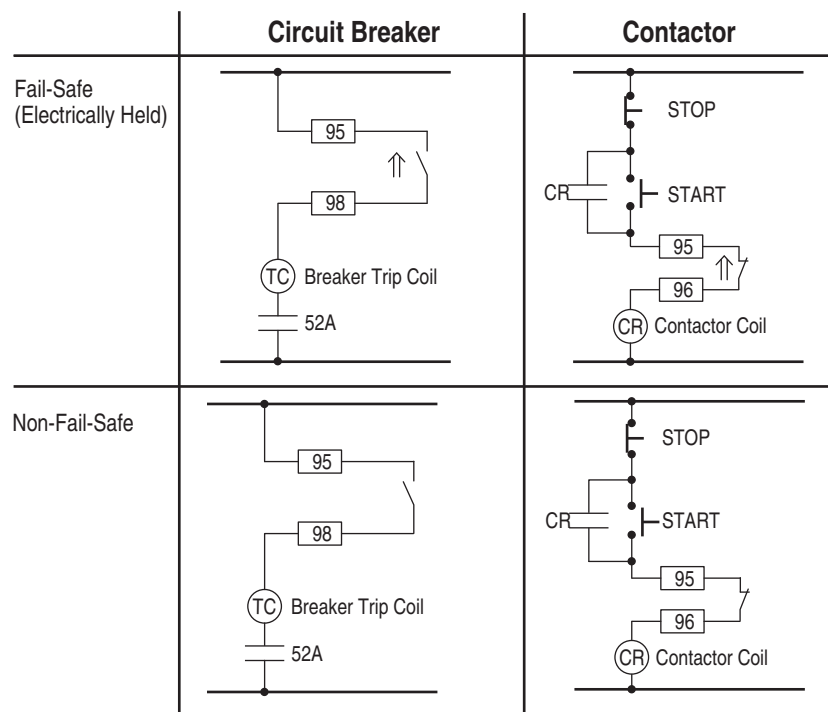

NOTE: Contact numbering changes are based on TRIP Fail-Safe setting.

Converter Module Connection

Figure 8 - Converter Module Connection

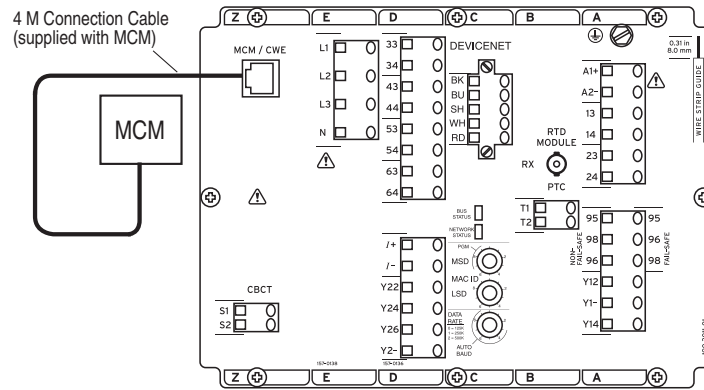

NOTE: The 825-P relay is not EMC-tested for converter module connecting cable lengths greater than the 4-meter cable that is supplied.

Figure 9 - Converter Module Dimensions

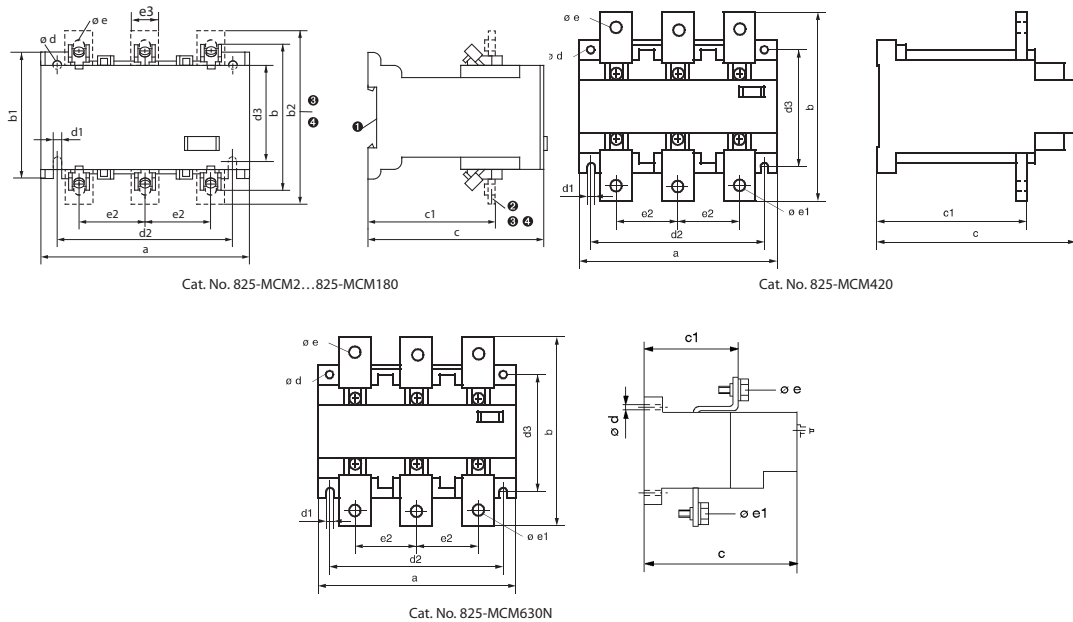

Dimensions

Cat. No.	a	b	c	c1	ø d	d1	d2	d3	ø e	ø e1	e2	b1	b2
825-MCM2, -MCM5, -MCM20	120	85	102	66	5.3	5.3	100	55	2x2.5 mm ²	—	38.5		
825-MCM180	120		102	72	5.3	5.3	100	55			38.5	75	110/118
825-MCM420	155	145	156	118	6.3	6.3	135	88	11	M10	48		
825-MCM630N	155	145	177	118	6.3	6.3	135	88	11	M10	48		

Core Balance Current Transformer Connections

Figure 10 - Core Balance Current Transformer Connections

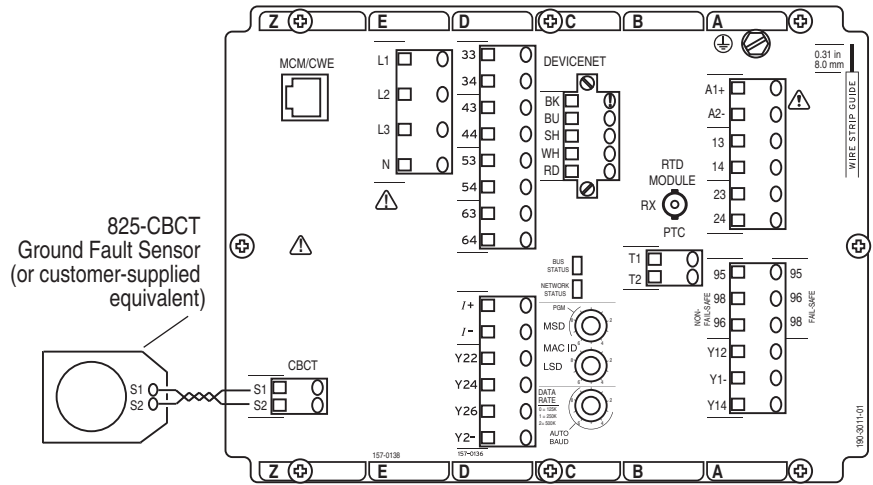
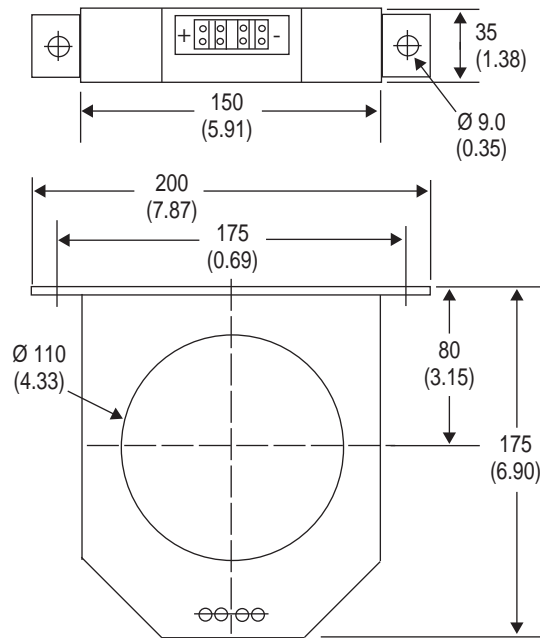

Figure 11 - 825-CBCT Dimensions [mm (in)]



Voltage Connections

With the Voltage Inputs option, the three-phase voltages can be directly connected for voltages under $300V_{L-L}$, wye-wye VT connected or open-delta VT connected. Figure 12 shows the three methods of connecting three-phase voltages.

Figure 12 - Voltage Connections

Direct Connection (Xfmr Connection = Wye)

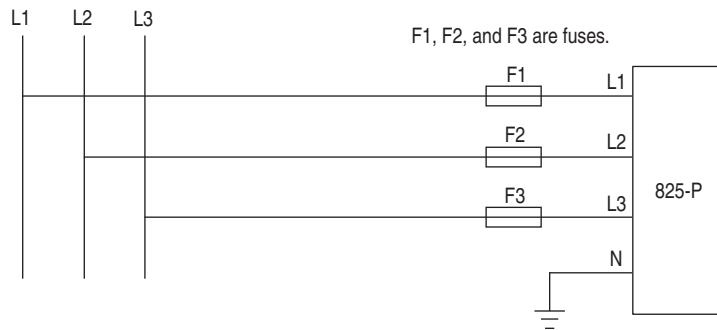

Wye-Wye VT Connection (Xfmr Connection = Wye)

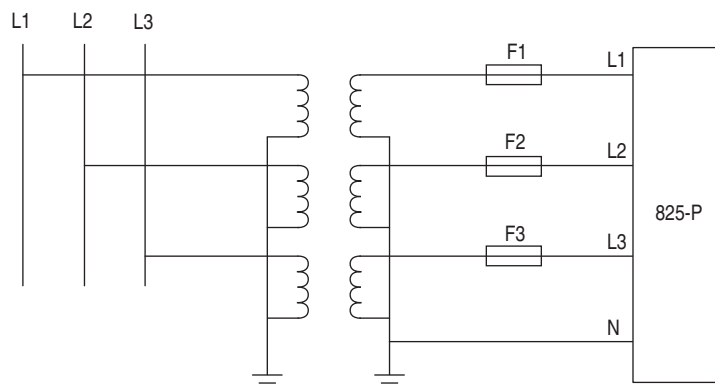

Open-Delta VT Connection (Xfmr Connection = Delta)

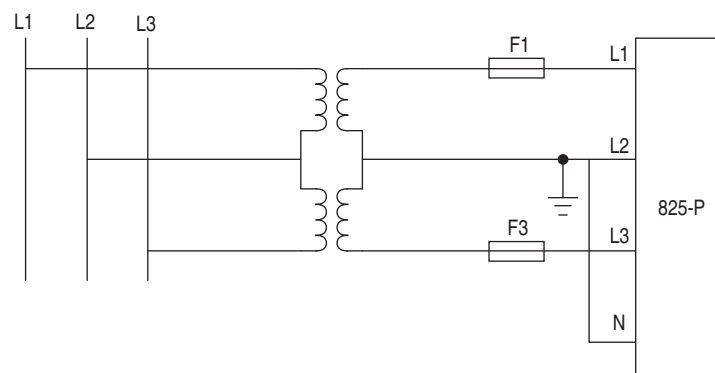

The recommended fuse is the Bussman KTK - 1/10, 1/10 ampere Limitron® fuse, or its equivalent.

Full-Voltage Non-Reversing Starter

Figure 13 - AC Connections without CBCTs

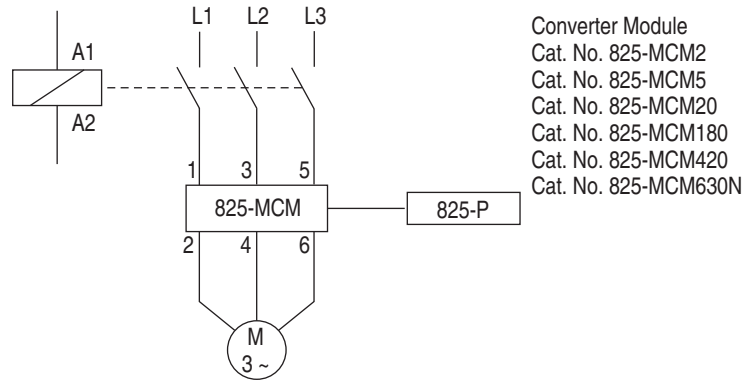

Figure 14 - AC Connections with CBCT

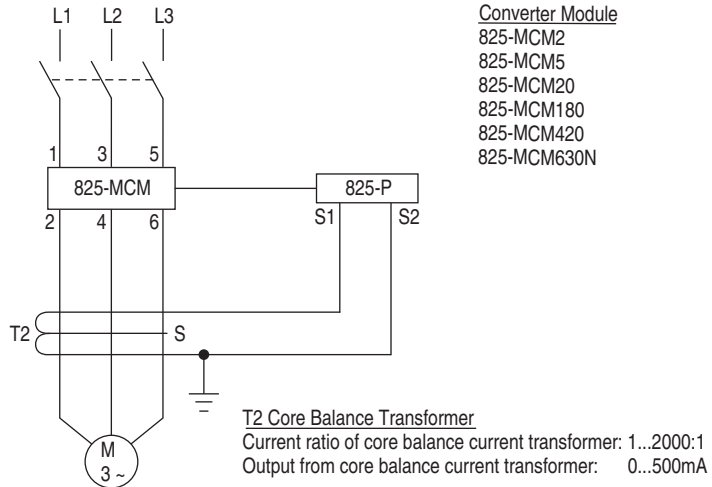

Figure 15 - AC Connections with Phase CTs and CBCT

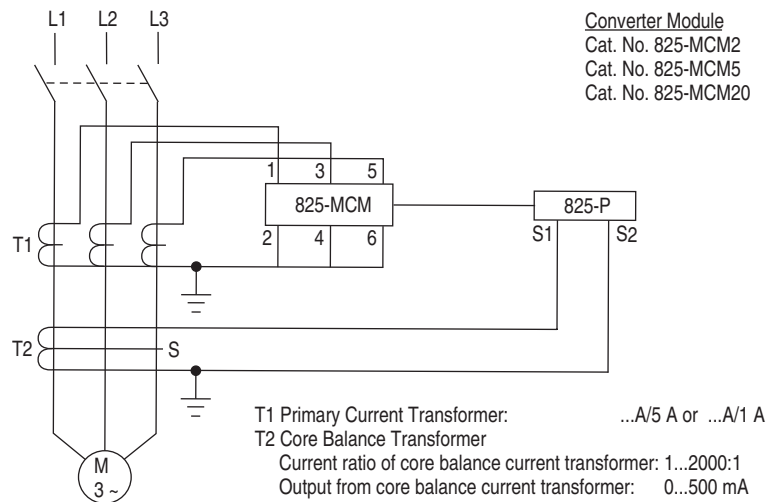
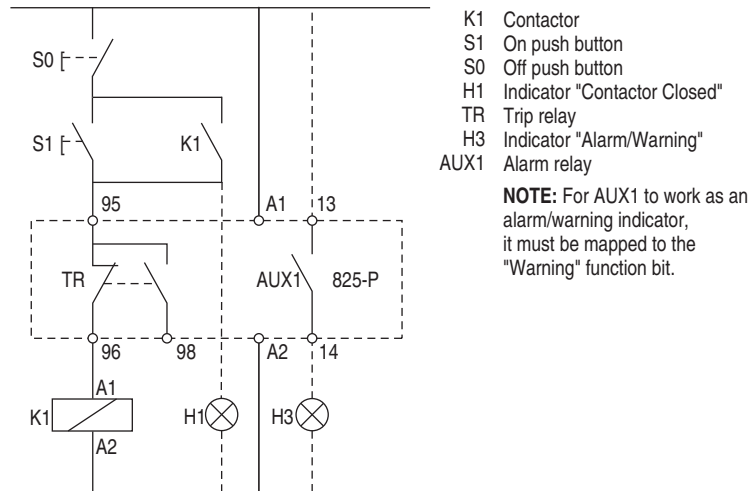

Figure 16 - Control Connections for a Full-voltage Non-reversing Starter



NOTE: For AUX1 to work as an alarm/warning indicator, it must be mapped to the "Warning" function bit.

Full-Voltage Reversing Starter

Full-voltage reversing starter motor applications require the following settings:

- TWO SPEED ENABLE = Y (Yes)
- IN1 = 0 0 0 0 0 0 1 0 0 (Speed 2)
- FVR PHASING = the phase (A, B, or C) that is not changing
- CT RATIO-2nd = CT RATIO
- MOTOR FLA-2nd = MOTOR FLA
- MOTOR LRC-2nd = MOTOR LRC
- MOTOR LRT-2nd = LOCKED ROTOR TIME
- ACCEL FACT-2nd = ACCEL FACTOR
- RUN ST TC-2nd = RUN STATE TIME K

Figure 17 - AC Connections for Full-voltage Reversing Starter

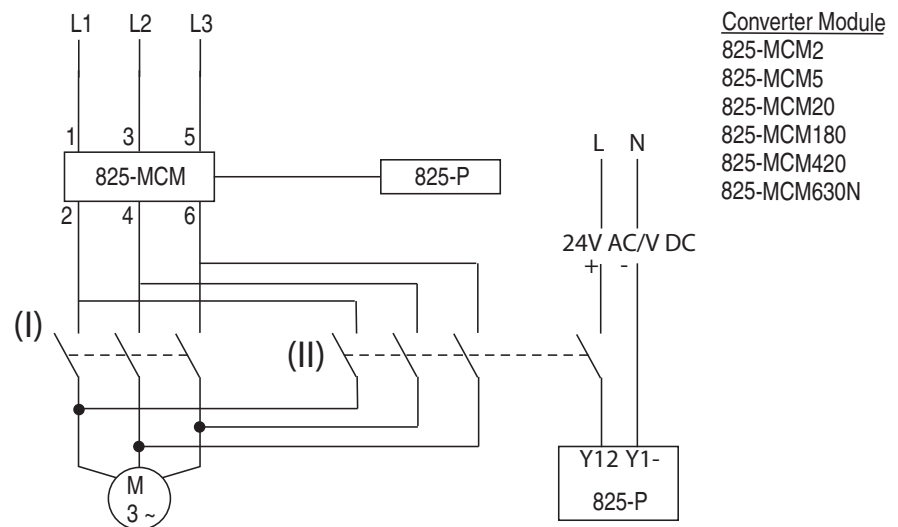

Star-Delta Starting

The star-delta application in the following figures requires the following auxiliary relay settings:

- AUX#H = 0001000 (Star), AUX# FAIL-SAFE = N
- AUX#H = 0000100 (Delta), AUX# FAIL-SAFE = N

Figure 18 - AC Connections for Star-Delta Starting

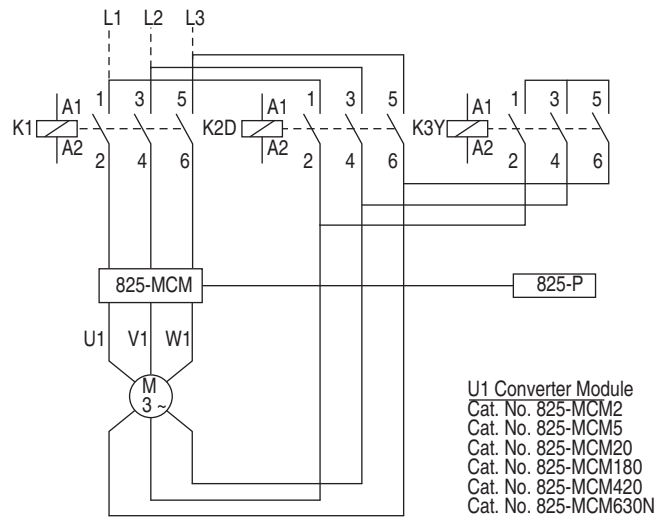
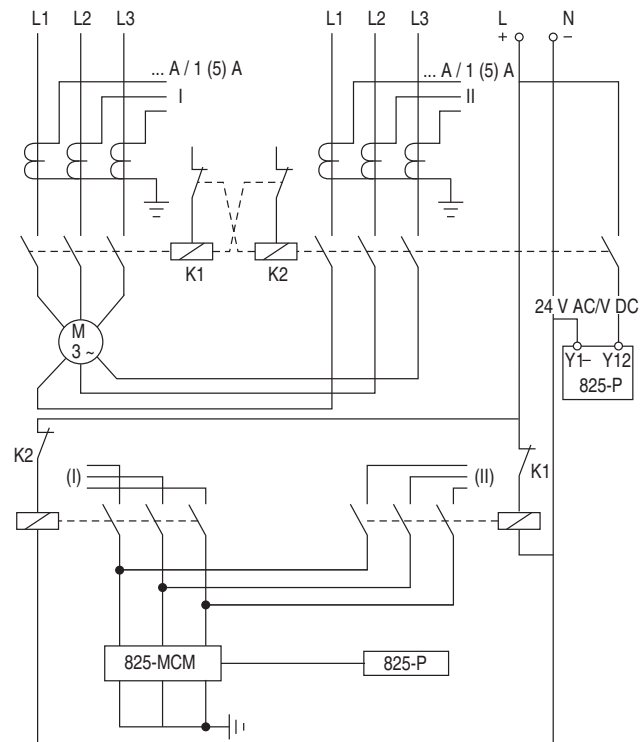

Figure 21 - AC Connections for a Two-Speed Motor with Primary CTs



ATTENTION: Disconnect or de-energize all external connections before opening this device. Contact with hazardous voltages and currents inside this device can cause electrical shock that can lead to injury or death. Equipment components are sensitive to electrostatic discharge (ESD). Undetectable permanent damage can result if you do not use proper ESD procedures. Ground yourself, your work surface, and this equipment, before removing any cover from this equipment. If your facility is not equipped to work with these components, contact Rockwell Automation about returning this device and related Rockwell Automation equipment for service.

Field Serviceability

The 825-P firmware can be upgraded in the field; refer to [Chapter 13: Firmware Upgrade Instructions](#). You know when a self-test failure has occurred by monitoring the front-panel messages. By using the metering functions, you know if the analog front-end (not monitored by relay self-test) is functional. Refer to [Chapter 11: Testing and Troubleshooting](#) for detailed testing and troubleshooting information. The only two components that can be replaced in the field are the power supply fuse and the real-time clock battery. A lithium battery powers the clock (date and time) if the external power source is lost or removed. The battery retains the thermal memory for the thermal overload function when the power source is lost or removed. The battery is a 3V lithium coin cell, Rayovac® BR2335 or equivalent. At room temperature (25°C), the battery operates nominally for ten years at rated load. When the relay is powered from an external source, the battery experiences a low self-discharge rate. Thus, battery life can extend well beyond ten years. The battery cannot be recharged.

Fuse Replacement

To replace the Power Supply fuse, do the following:

1. De-energize the relay.
2. Remove the eight rear-panel screws, the ground screw, and the relay rear-panel.
3. Remove the Slot A printed circuit board.
4. Locate the fuse on the board.
5. Remove the fuse from the fuse holder.
6. Replace the fuse with a BUSS 2A/250V ABC (ceramic) or equivalent.
7. Insert the printed circuit board into Slot A.
8. Reinstall the relay rear-panel and ground screw, and then energize the relay.

Real-Time Clock Battery Replacement

To replace the real-time clock battery, do the following:

1. De-energize the relay.
2. Remove the eight rear-panel screws, the ground screw, and the relay rear-panel.
3. Remove the Slot B printed circuit board.
4. Locate the battery clip (holder) on the board.
5. Remove the battery from beneath the clip.
6. Properly dispose of the old battery.
7. Install the new battery with the positive (+) side facing up.
8. Insert the printed circuit board into Slot B.
9. Reinstall the relay rear-panel and ground screw, and then energize the relay.
10. Set the relay date and time.

Front Panel Operation

Front Panel Layout

The 825-P Relay front-panel interface consists of two LEDs, an LCD display, a seven-button keypad, and an EIA-232 serial port connector. The front-panel layout is shown in Figure 22.

Figure 22 - Relay Front Panel

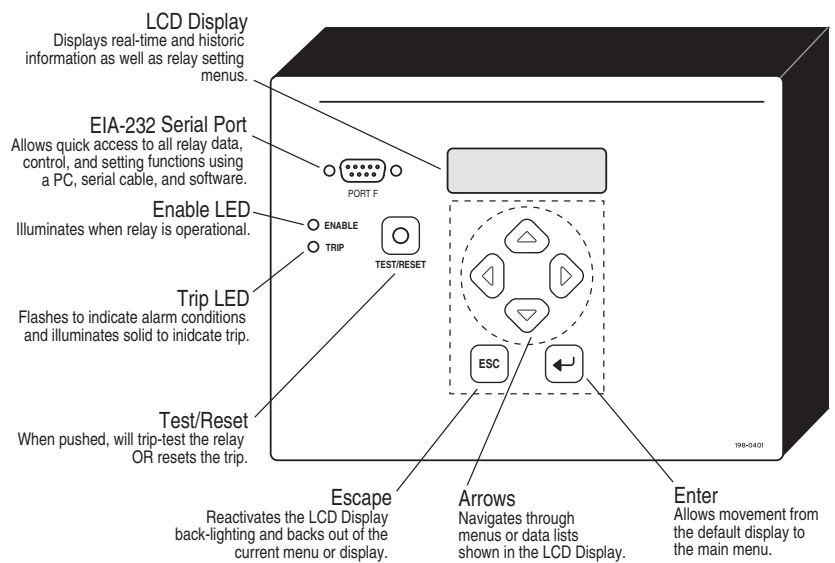

Normal Front Panel Display

In normal operation, the relay ENABLE LED is illuminated and the LCD display screen is on. The LCD screen rotates displays showing each screen for about two seconds before moving to the next. The default rotating display screens include Unit ID Line 1, Unit ID Line 2, line currents, and voltages (if available). Enable the relay to add display messages as noted in the Display Enable settings in Table 41.

Figure 23 - Default Display Screen

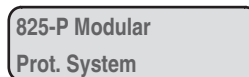

Use the UNIT ID LINE 1 (RID) and UNIT ID LINE 2 (TID) settings described in Identifier Settings to change the contents of the information shown in Figure 23.

If the front panel was in Access Level 2, it automatically returns to the default display when the display times out. For more information, see Table 40.

The display changes for the following relay conditions in the order of precedence (see Table 3):

- Status failure
- Trip condition time to trip (if under 10000 seconds)
- Warning
- Lockout start request
- Emergency start in progress

Front Panel Automatic Messages

The relay displays automatic messages under the conditions described in Table 3.

Table 3 - Front Panel Automatic Messages

Condition	Front Panel Message
Relay detecting any failure	Displays the type of latest failure (see Chapter 11).
Relay trip has occurred	Displays the type or cause of the trip. (See the list of the types of Trip messages under the heading Front Panel Messages).
Motor running overload	Displays the predicted time to thermal element trip in seconds.
Relay alarm condition has occurred	Displays the type of alarm (see Alarm or Warning Messages).
When a start is requested during a lockout condition	Displays the type of lockout condition (see Lockout Messages).
Control input set to disable protection	Displays "Protect Disabled By Control Input".
During emergency start	Displays "Emergency Start".

Front Panel Messages

Each time the relay trips, it automatically displays a front-panel message and the Trip LED illuminates. If a trip occurs during a critical alarm status condition, the Trip LED flashes (see [Self-Tests on page 156](#)).

Trip message

The Trip message describes the type of trip that occurred:

<ul style="list-style-type: none"> • Overload Trip • Locked Rotor Trip • Undercurrent Trip • Jam Trip • Current Imbalance Trip • Short Circuit Trip • Ground Fault Trip • Speed Switch Trip 	<ul style="list-style-type: none"> • Undervoltage Trip • Overvoltage Trip • Underpower Trip • Power Factor Trip • Reactive Power Trip • Phase Reversal Trip • Underfrequency Trip • Overfrequency Trip 	<ul style="list-style-type: none"> • RTD Trip • PTC Trip • Start Time Trip • RTD Fail Trip • PTC Fail Trip • Comm Idle Loss Trip • Remote Trip • Comm Fail Trip
---	--	---

Alarm or Warning Messages

Each time the relay is in a warning condition with the Trip LED flashing, the front-panel displays the corresponding warning message.

The Warning message describes the type of warning that is occurring:

<ul style="list-style-type: none"> • Overload Warning • Undercurrent Warning • Jam Warning • Current Imbalance Warning • Ground Fault Warning • Short Circuit Warning • Speed Switch Warning 	<ul style="list-style-type: none"> • Undervoltage Warning • Overvoltage Warning • Underpower Warning • Power Factor Warning • Reactive Power Warning • Underfrequency Warning • Overfrequency Warning 	<ul style="list-style-type: none"> • RTD Warning • RTD Failure • MCM/CWE Failure • PTC Failure • Comm. Loss Warning • Comm. Idle Warning • Comm. Fault Warning
---	--	---

The relay automatically displays a thermal time to trip for an impending thermal overload. See Figure 24.

Figure 24 - Trip Message Sample



Lockout Messages

- TCU Lockout
- Start/Hr Lockout
- Min Off Lockout
- Restart Lockout







Front Panel Menus and Operations

The 825-P front panel gives you access to most of the information that the relay measures and stores. You can also use the front panel controls to view or modify relay settings.

All of the front panel functions are accessible using the seven-button keypad and LCD display. Use the keypad to maneuver within the front panel's menu structure, as described in detail throughout the remainder of this section.

Table 4 describes the function of each push button.

Table 4 - Front Panel Push Button Functions

Push Button	Function
 UpArrow	Move up within a menu or data list. While editing a setting value, increase the value of the underlined digit.
 DownArrow	Move down within a menu or data list. While editing a setting value, decrease the value of the underlined digit.
 LeftArrow	Move the cursor to the left. While viewing event data, move to data for a newer event.
 RightArrow	Move the cursor to the right. While viewing Event data, move to the data for an older event.
 Esc	Re-activate the front panel display back-lighting. Back out from the current menu or display.
 Enter	Move from the default display to the main menu. Select the menu item at the cursor. Select the displayed setting to edit the setting.
 Trip/Reset	The Test/Reset push button has two functions if it has not been disabled. Pressing the Test/Reset push button resets the Trip LED and the Trip output of the relay. If a trip condition is active, the front-panel message displays the following: Reset Failed TRIP is active To test the trip output, press the Test/Reset push button for longer than two seconds. The Test/Reset push button is disabled when Disable settings are active

The Test/Reset push button has two functions if it has not been disabled.

Pressing the Test/Reset push button resets the Trip LED and the Trip output of the relay. If a trip condition is active, the front-panel message displays the following:

Reset Failed

TRIP is active

To test the trip output, press the Test/Reset push button for longer than two seconds.

The Test/Reset push button is disabled when Disable settings are active (see Table 44).

Front Panel Security

Front Panel Access Levels

The relay front panel typically operates at Access Level 1 and allows any user to view relay measurements and settings. Some activities, such as editing settings and controlling output contacts, are restricted to those operators who know the relay Access Level 2 password when enabled. The factory default setting for the Access Level 2 password is “DISABLED”, which provides unrestricted access.

In the figures that follow, restricted activities are marked with the padlock symbol, shown in Figure 25.

Figure 25 - Access Level Security Padlock Symbol



Before you can perform a front panel menu activity that is marked with the padlock symbol, you must enter the correct Access Level 2 password. After you have correctly entered the password, you can perform other Access Level 2 activities without re-entering the password.

Access Level 2 Password Entry

When you try to perform an Access Level 2 activity, the relay determines whether you have entered the correct Access Level 2 password since the front panel inactivity timer expired or since the “Reset Access Lvl” command has been executed from the Main Menu. If you have not, the relay displays the screen shown in the Password Entry screen shown in Figure 26 for you to enter the password.

Figure 26 - Password Entry Screen

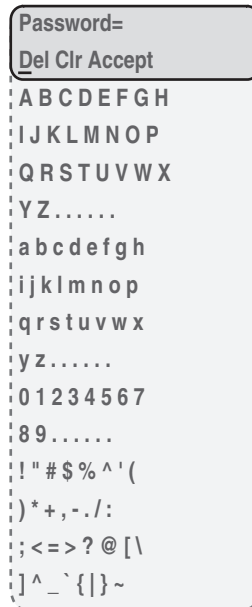

To Enter Password

Perform these steps to enter the correct password to issue an Access Level 2 function or to change the Access Level 2 password.

1. Press the DownArrow push button twice. A blinking cursor appears in the first character position of the password and an underline appears beneath the character (letter) A in the lower line of the display.
2. Underline the first character of the password by moving through the characters shown in Figure 26. Use the LeftArrow and RightArrow push buttons to move the underline to the left and right and the UpArrow and DownArrow push buttons to move to other character rows.
3. With the correct first character underlined, press the Enter push button. The first character appears in the upper line of the display and the blinking cursor moves one character to the right.
4. Using the arrow push buttons, continue to move within the character table and select each of the characters to build the Access Level 2 password.

NOTE: The factory default Access Level 2 password is DISABLED.

5. With the correct Access Level 2 password visible in the upper line of the display, use the up and right arrow to select Accept.
6. Press the Enter push button to accept the password shown in the upper line of the display.
7. If the password is correct, the relay displays the requested setting.
8. Press the Enter push button to continue your task.

9. If the password is incorrect, the relay displays the message **Invalid Password**.
10. Press the Enter push button to return to your previous task.

To Correct Entry Errors

To correct password entries, do the following:

1. If the cursor in the upper line of the display is blinking, press the Esc push button once.
2. Use the arrow push buttons to move the underline cursor to the position of the incorrect letter.
3. With the incorrect letter underlined, press the DownArrow push button. The blinking cursor reappears in the upper line of the display and the underline cursor appears in the lower line.
 - **Add New Character.** To substitute a new character in the location of the blinking cursor, use arrow push buttons to move the underline cursor to the location of the character that you want in the character table; then press Enter.
 - **Delete Character.** To delete the character at the blinking cursor, use the arrow push buttons to move the underline cursor to Del and press the Enter push button.
 - **Clear Password.** To clear the entire password and start over, use the arrow push buttons to move the underline cursor to Clr and press the Enter push button.
4. Continue making corrections until the password appears in the upper line of the display.
5. With the correct Access Level 2 password visible in the upper line of the display, use the arrows to move the underline cursor to **ACCEPT**.
6. Press the Enter push button to accept the password shown in the upper line of the display.
7. If the password is correct, the relay continues the task.
8. Press enter to continue your task. If the password was incorrect, the relay displays the message **Invalid Password**.
9. Press the Enter push button to return to your password entry.
10. Repeat Steps 1...9 until you enter the correct password.
11. When you have completed changing settings, use the Main Menu command **Reset Access Lvl** (described in the next section) to reset the Access Level to Level 1 so that unauthorized access is prevented. (The access level will remain at Level 2 until the front panel backlight times out or the **Reset Access Lvl** command is executed.)

Front Panel Main Menu

All access to information and relay settings through the front panel starts at the relay main menu. The remainder of this section describes the use of the main and lower level menus.

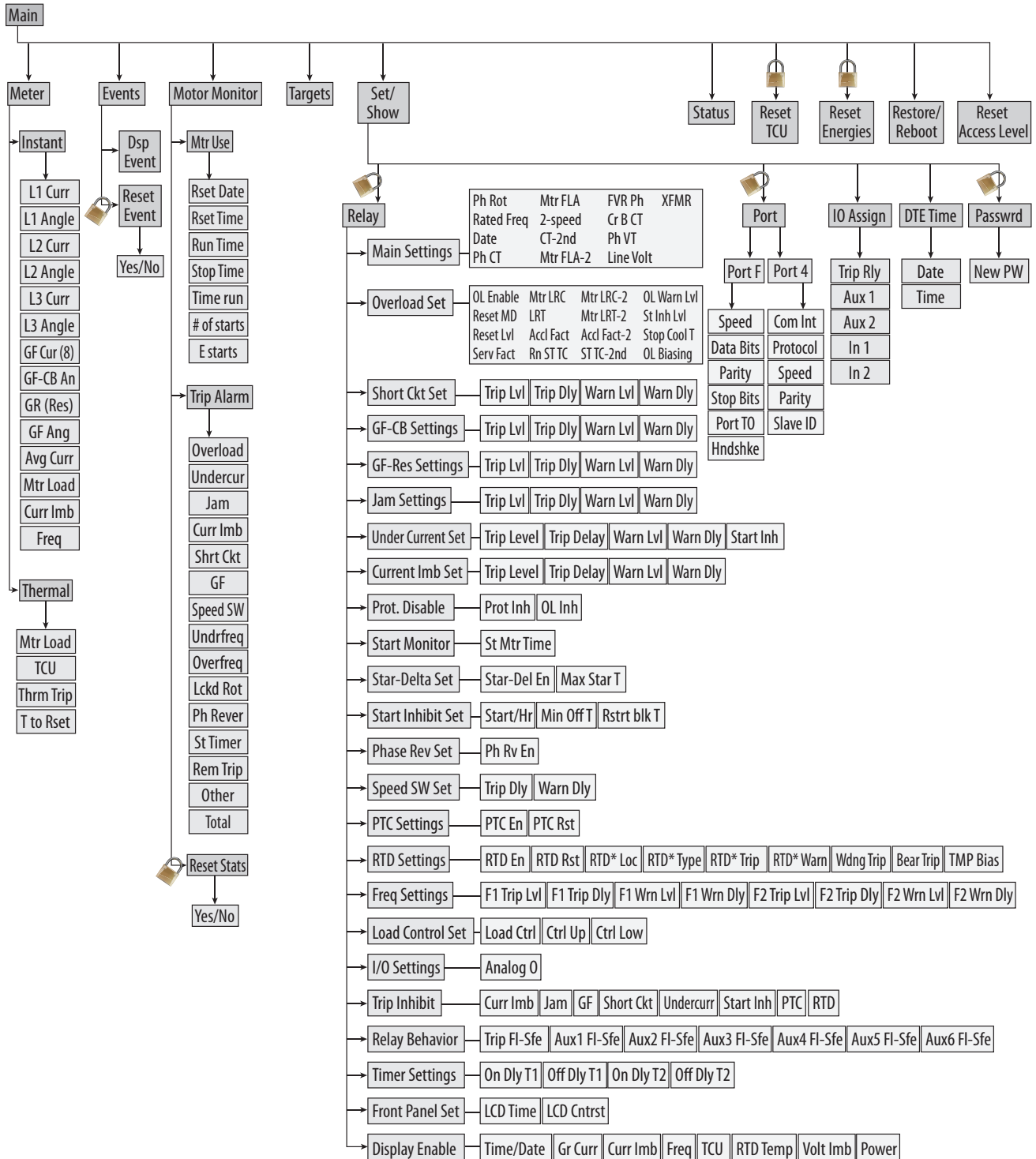

View or Change Settings Using the Front Panel

Enter the front panel menu by pressing the Esc button. It displays the following message:



```
MAIN
Meter
```

Scroll through the menu by using the DownArrow and UpArrow push buttons until the display shows the appropriate menu.



```
Targets
SET/SHOW
```

The cursor (underline) indicates the selected menu item. Press Enter to navigate into the submenu.

Scroll through the parameters by using the DownArrow and UpArrow buttons.



```
SET/SHOW
RELAY
```

Press the Enter button to change a parameter setting. Use the UpArrow and DownArrow and the LeftArrow and RightArrow push buttons to modify the parameter. After changing the parameter, press the ESC push button until the following message appears:

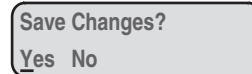

```
Save Changes?
Yes No
```

Select and enter the appropriate command by pressing the Enter push button. Select Yes to save the settings changes and No to discard the changes.

NOTE: Each 825-P is shipped with default factory settings. Calculate the settings for your motor to ensure secure and dependable protection.

Figure 27 shows a front-panel menu navigation example to enter the Phase Rotation (ABC, ACB) setting.

Figure 27 - Front Panel Setting Entry Example

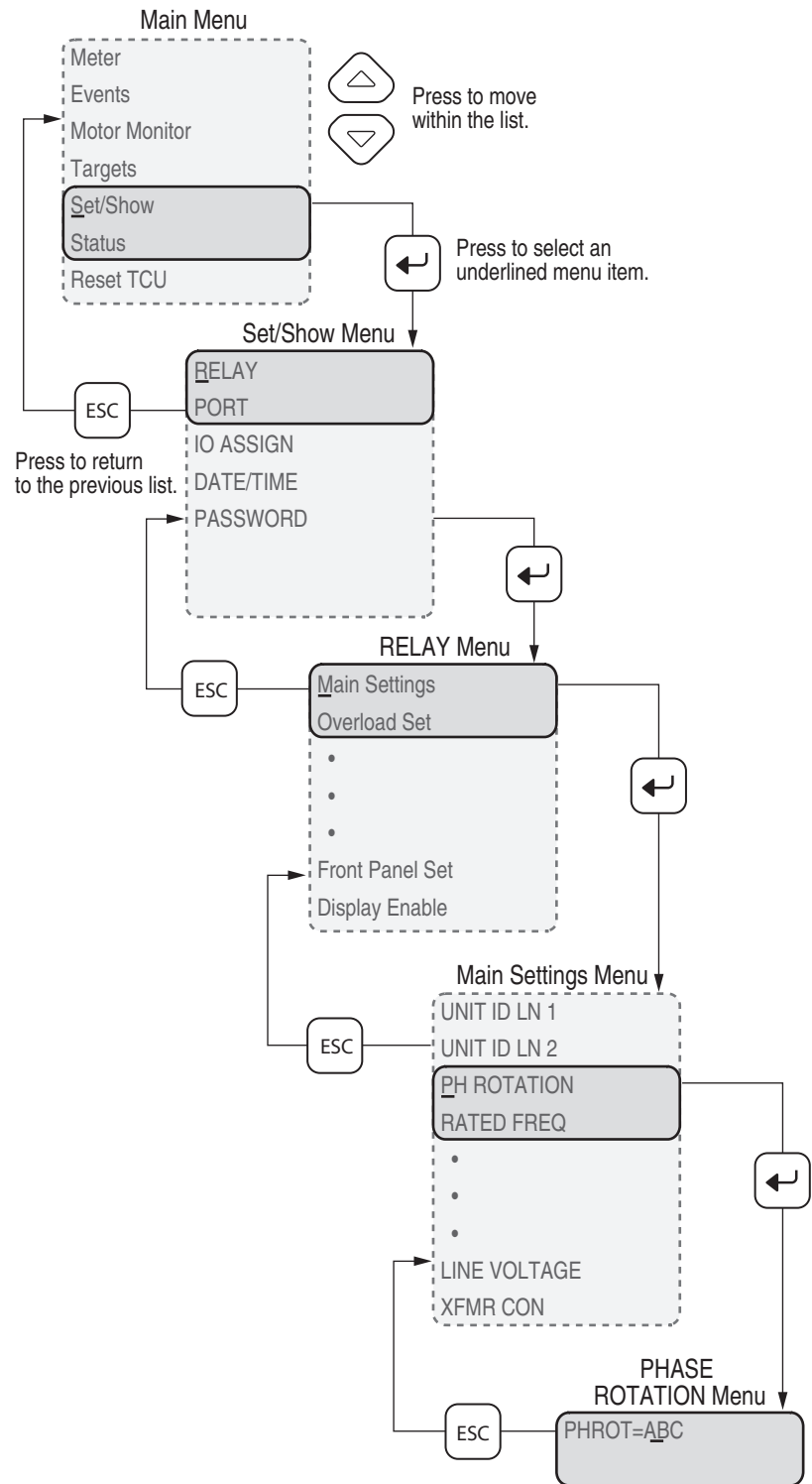

Setting Entry Error Messages

As you enter relay settings, the relay checks the setting entered against the setting's own range as published on the relay setting sheet. If an entered setting falls outside its range, the relay immediately responds with the message "Out of Range" and prompts you to reenter the setting.

In addition to the immediate range check, several of the settings have interdependency checks with other settings. The relay checks setting interdependencies after you answer Y to the "Save Settings?" prompt, but before the settings are stored. If any one of these checks fail, the relay issues one of the error messages shown in the Table 5, and returns you to the settings list for a correction.

Table 5 - Setting Interdependency Error Messages

Error Message	Setting /Function	Correct the Condition
50NnP must be within xx.xx and yy.yy (n = 1 or 2)	Ground Fault–Core Balance	Modify the 50N1P or 50N2P setting to satisfy the requirement shown in the error message.
50PnP must be less than xx.xx (n = 1 or 2)	Short Circuit	Modify the 50P1P or 50P2P setting to satisfy the requirement shown in the error message.
CTRn,FLAn Setting Combination Out of Range (n = 1 or 2)	Main Settings	Modify the CTRn or FLAn setting to satisfy: 0.5 £ (FLAn/CTRn) £ 2.5 when MCM2 is used 1.0£ (FLAn/CTRn) £ 5.0 when MCM5 is used 2.5 £ (FLAn/CTRn) £ 20 when MCM20 is used 20 £ (FLAn/CTRn) £ 180 when MCM180 is used 160 £ (FLAn/CTRn) £ 630 when MCM630 is used
LRA _n must be less than: xxx (n = 1 or 2)	Overload	Modify the LRA1 or LRA2 setting to satisfy the requirement shown in the error message.
Minimum STOP COOL TIME: xxxx min	Overload	Modify the COOLTIME setting to satisfy the requirement shown in the error message.
Only one ambient RTD allowed (n = 1–12)	RTD	Modify the RTD location setting (RTDnLOC) to satisfy the requirement shown in the error message.
PTR Setting Out of Range	Main Settings	Modify VNOM or PTR setting to satisfy: 100 £ (VNOM/PTR) £ 250
Warning: Duplicate Assignment	Input Mapping	Modify INn assignment ensuring that input is not assigned to more than one element.
Warning: Verify 50PnP is lower than MCM/CWE saturation current. Save Changes (Y/N)? (n = 1 or 2)	Short Circuit	Answer Y if you are using MCM630N. If you are using MCM630, you must modify the 50P1P or 50P2P setting below its saturation current to ensure proper protection.
Warning: Verify LRA _n is lower than MCM/CWE saturation current Save Changes (Y/N)? (n = 1 or 2)	Overload	Answer Y if you are using MCM630N. If you are using MCM630, you must modify the LRA1 or LRA2 setting below its saturation current to ensure proper protection.

Hardware Commissioning

All hardware that is added to the 825-P must be installed and commissioned individually. Listed below are the processes required to commission an 825-P for a specific Converter Module, Optional I/O Module, Optional Voltage Module, and Optional Communication Module.

Connecting a Converter Module (MCM)

- Connect the MCM module to 825-P
- Apply power to the 825-P base relay
- The following fault will be displayed:

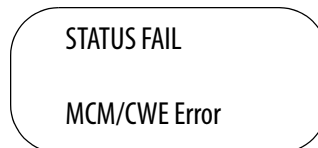

A screenshot of a status fail message displayed in a rounded rectangular box. The text reads "STATUS FAIL" followed by "MCM/CWE Error" on the next line.

- Navigate to Main > Status to view the Status display
- The display will show the following message:

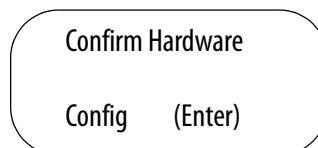

A screenshot of a confirm hardware message displayed in a rounded rectangular box. The text reads "Confirm Hardware" followed by "Config (Enter)" on the next line.

- Press the Enter key to confirm that you want this hardware change

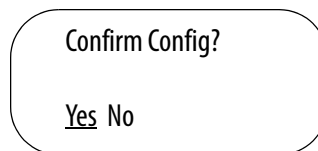

A screenshot of a confirm config message displayed in a rounded rectangular box. The text reads "Confirm Config?" followed by "Yes No" on the next line.

- Select Yes to confirm the new hardware configuration, and the display will show:

Config Accepted
Enter to Reboot

- Press Enter to reboot the relay.
- If existing configuration parameters are not proper for the specific hardware configuration, then the following message will be displayed

Setting Mismatch
Adjust Settings

- To correct the configuration parameters reset the relay to the default parameters for the specific hardware configuration by navigating to Main->Reboot/Restore and select Restore Defaults in which the following display will appear:

Restore Default
No Yes

- Select Yes and the relay will reboot. With the updated configuration parameters, the display will show the following error message:

STATUS FAIL
MCM/CWE Error

- Navigate to Main > Status to view the Status display
- The display will show the following message:

Confirm Hardware
Config (Enter)

- Press the Enter key to confirm that you want this hardware change

Confirm Config?
Yes No

- Select Yes to confirm the new hardware configuration, and the display will show:

Config Accepted
Enter to Reboot

- Press Enter to Reboot the relay

Adding an Optional I/O Card

- Remove control power from the relay, and remove the back cover
- Add the optional I/O card into Slot D in the 825-P
- Replace the cover and reapply control power to the relay
- The 825-P will detect a hardware configuration change and display the following message:

STATUS Fail
I/O Card Failure

- Navigate to Main > Status to view the Status display
- The display will show the following message:

Confirm Hardware
Config (Enter)

- Press the Enter key to confirm that you want this hardware change

Confirm Config?
Yes No

- Select Yes to confirm the new hardware configuration, and the display will show:

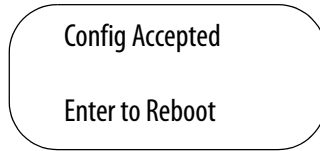

- Press Enter to reboot the relay

Adding the Optional Voltage Card

- Remove control power from the relay, and remove the back cover
- Add the optional Voltage Card into Slot E in the 825-P
- Replace the cover and reapply control power to the relay
- The 825-P will detect a hardware configuration change and display the following message:

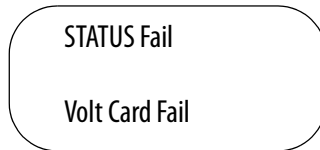

- Navigate to Main > Status to view the Status display
- The display will show the following message:

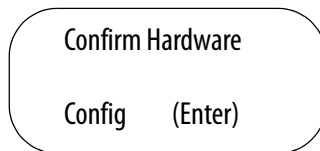

- Press the Enter key to confirm that you want this hardware change

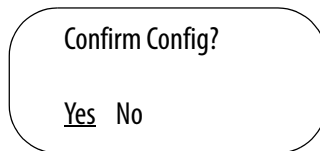

- Select Yes to confirm the new hardware configuration, and the display will show:

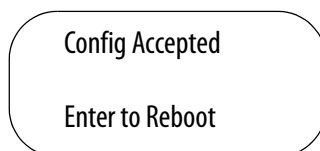

- Press Enter to reboot the relay

Adding the Optional Communication Card

- Remove control power from the relay, and remove the back cover
- Add the optional communication card into Slot C in the 825-P
- Replace the cover and reapply control power to the relay
- Navigate to Main > Status to view the Status display
- If the display shows the following message:

Confirm Hardware
Config (Enter)

- Press the Enter key to confirm that you want this hardware change

Confirm Config?
Yes No

- Select Yes to confirm the new hardware configuration, and the display will show:

Config Accepted
Enter to Reboot

- Press Enter to reboot the relay
- If there is an address conflict on the internal communication bus, the display show the following message:

COMMFLT
Warning

- To correct this conflict, navigate to Main > Set/Show > Port > Port 4 and select the parameter named “Modbus Slave ID”
- Change the Modbus Slave ID to the value of 247
- Press the ESC key, and the display will show the following message:

Save Changes?
Yes No

- Select Yes to resolve the address conflict

Removing an Option Card

- Remove control power from the relay, and remove the back cover
- Remove the option card from the 825-P
- Replace the cover and reapply control power to the relay
- The display will show the following message to indicate that something is different with the hardware configuration:

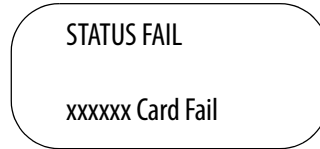

STATUS FAIL
xxxxxx Card Fail

- Navigate to Main > Status to view the Status display
- The display will show the following message:

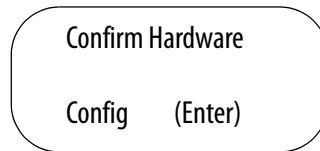

Confirm Hardware
Config (Enter)

- Press the Enter key to confirm that you want this hardware change

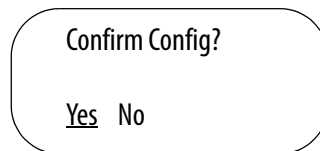

Confirm Config?
Yes No

- Select Yes to confirm the new hardware configuration, and the display will show:

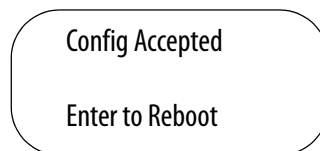

Config Accepted
Enter to Reboot

- Press Enter to reboot the relay

Using MPS Explorer

Software Overview

The MPS Explorer software allows users to access settings and data on Modular Protection Systems (MPS) for motors. The 825-P connects to a PC via the serial communications port (Port F) on the front face where settings can be configured. Real-time monitoring of metering data and diagnostic information can also be viewed on the front face. The data that is collected can be exported for analysis in other software, such as Microsoft Excel. Graphical output, ranging from pilot lights to gauges and time plots, can be modified for a specific application.

MPS Explorer software is available for download at:

<http://ab.rockwellautomation.com/Circuit-and-Load-Protection/Motor-Protection/Bulletin-825P#/tab4>

To install the software, download the Windows Installer Package file (.msi) and follow the prompts to the MPS Explorer Wizard.

Communications Settings

The communications settings can be accessed from the **MPS > Communications Settings** menu. When configuring these settings, it is critical that they match the settings on the front panel of the 825-P for Port-F.

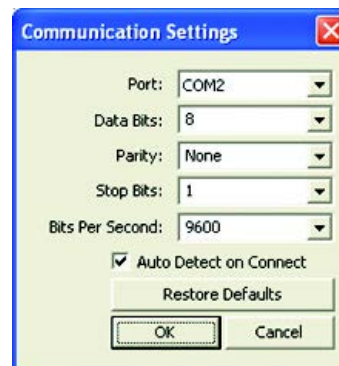

Connection/Access Level

Once the communication settings have been configured and the 825-P is connected via the serial port, connection can be established. To connect to the 825-P, navigate to the **MPS > Connect** or click the . If the settings are correct, the access level dialog box will appear.

Access Level 0: There is no access to MPS data. It is used to manually log off and prevent settings from being changed or monitored.

Access Level 1: This level allows only monitoring of parameter and metering values.



Access Level 2: Full access to the 825-P, including the configuration of parameter values.

To change access levels, select the appropriate button. The access levels must be changed in ascending order. To obtain access to Level 2, access must first be obtained in Levels 0 and 1. If the application requires the use of a password, it can be typed into the text box and click the “Send Password” button. Once the first successful connection has been established, the software will display the device status, by default.



To disconnect from the 825-P relay, use the  button or navigate to **MPS > Disconnect**. Disconnecting from the 825-P will result in the access level being downgraded to 0. MPS Explorer will automatically detect the absence of the 825-P when the program is closed, but it is recommended that the user disconnect before removing power or physically disconnecting the relay.



Data Management

The user is able to change the parameters at any time, regardless of the connection status. The settings can be saved and the file can be loaded on to replacement components. There are two buttons on the toolbar that perform operations pertaining to transfer of data and parameters. The software and the 825-P can be synchronized by both buttons. The  button is used to Apply the Configuration (Download) from the MPS Explorer software to the device, while the  button is used to Get MPS Settings (Upload) the current hardware settings from the device to the software. After the device has been connected to MPS Explorer, the screen will indicate the status of each setting. An active setting will be displayed in black, while an inactive setting will be

grayed. When a change to an individual setting is made, an asterisk will appear before the short name.

Save/Open Configuration Files

The software allows the user to save configured parameter values to local disk drives. This option can be used to backup configurations and reduce engineering time when working with multiple relays all requiring similar settings.









To save the configuration to a local disk, click the  button or navigate to **File > Save Configuration**. A dialog box will appear prompting the user to specify a target location and name to save the file. To open a previously saved configuration, click the  button or navigate to **File > Open Configuration File**. The opened file will only display the parameters on the screen and will not be changed on the device until they are downloaded.

Button Summary

MPS Explorer software incorporates a large number of functions displayed on the toolbar.

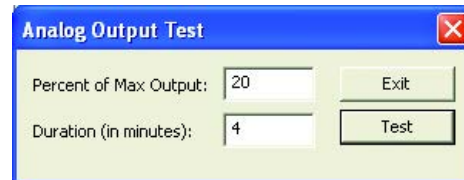

Table 6 -

Symbol	Name	Description
	Test relay analog current output	Configurable output with a specified percentage of the full analog output current for a defined period of time
	View motor operation statistics	Displays the operating statistics of the motor connected to the 825-P
	View serialized events	Display, sort, and export the serialized event data
	View relay self-test status	Display the status of the 825-P including option card and DeviceNet status
	View relay metering data	The instantaneous metering screen allows collection and export of data in real time and is independent of the main screen
	View event summary report	Displays the last five major events
	View relay thermal metering data	Displays thermal data from up to 12 locations
	View relay word information	Displays the status of relay elements

ANA (Test Analog Output)

The Test Analog Output function will output a specified percentage of the full analog output current for a defined period of time. Enter the percentage and duration, click the **Test** button and monitor the analog output for the expected current.



The screenshot shows a dialog box titled "Analog Output Test" with a close button (X) in the top right corner. It contains two input fields and two buttons. The first input field is labeled "Percent of Max Output:" and contains the value "20". To its right is an "Exit" button. The second input field is labeled "Duration (in minutes):" and contains the value "4". To its right is a "Test" button.

MOT (Motor Operating Statistics)

The Motor Operating Statistics function displays the operating statistics of the motor that is connected to the 825-P relay. Newer firmware versions (R107+) display the trip and alarm accumulators.



The screenshot shows a dialog box titled "Motor Operating Statistics Report" with a close button (X) in the top right corner. It displays a list of statistics and two buttons. The statistics are:

Operating Since:	08/22/2012
Elapsed Time:	07:05:18
Running Time:	0:00:00
Stopped Time:	>2:01:52
Time Running:	0.0%
Number of Starts:	0
Emergency Starts:	0

To the right of the statistics are two buttons: "Exit" and "Refresh".

SER (Serialized Events Recording)

The Serialized Events Recording function displays the ongoing events that can be sorted by date, time, element or state.

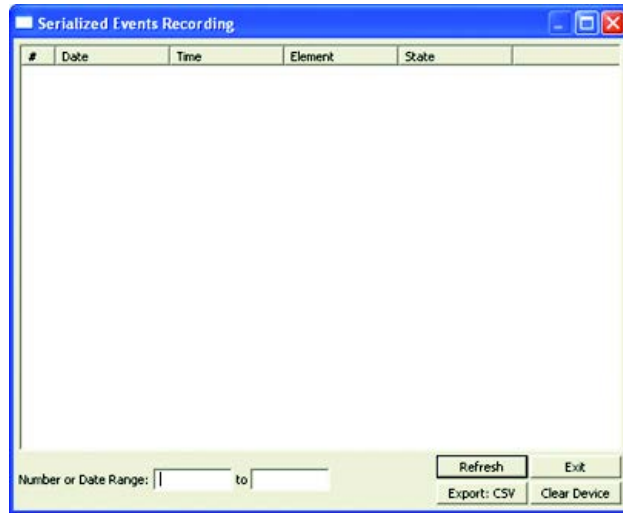

Dialog buttons function as follows:

- Exit:** Close the dialog window. All data that was acquired will be lost.
- Refresh:** Acquire a list of events based upon the contents of the range edit boxes.

Box 1	Box 2	Data Acquired
Empty	Empty	All Events
Number	Number	Events between and including number limits
Number	Empty	Events starting with the number entered through most recent event
Date	Date	Events between and including date limits
Date	Empty	Events starting with the date entered up to the most recent event

- Clear Device:** Physically clear the serialized events from the 825-P. This cannot be recovered.
- Export:** CSV: Export the data in the list to a Comma Separated Value file.

STA (Relay Status)

The Relay Status function displays the hardware status including the option cards and DeviceNet status. If the hardware configuration has been modified, the user

is able to confirm or ignore the changes from this screen. The relay will reboot when the hardware changes are confirmed.

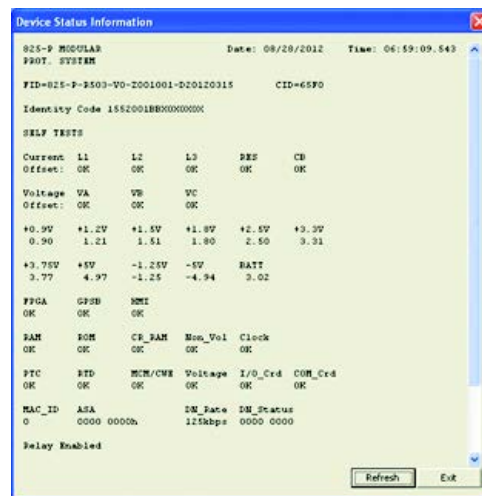

SUM (Events Summary Report)

The Event Summary Report function displays the five most recent events

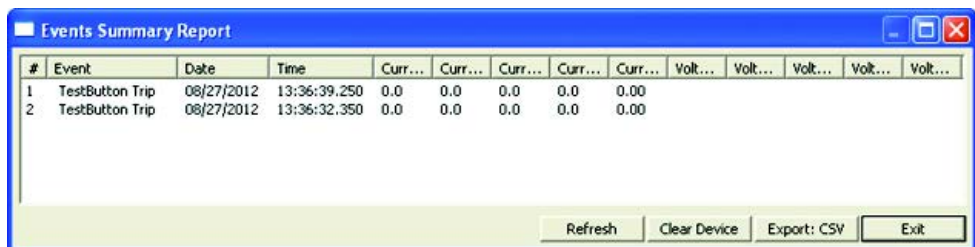

MET (Instantaneous Metering) RTD (RTD/Thermal Metering)

The Instantaneous and Thermal Metering functions display the collection and export data in real time. The user is able to configure the parameters that are displayed for both instantaneous and thermal metering.

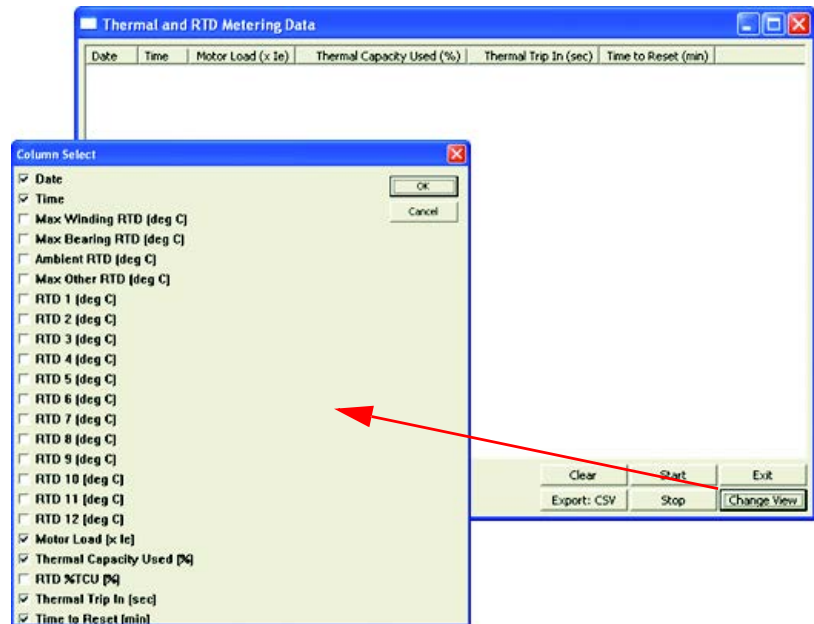

TAR (Display Target Words)

The Display Target Words function shows the status of relay elements and is independent from the main window. To view the full bit description, place the cursor over any masked heading.

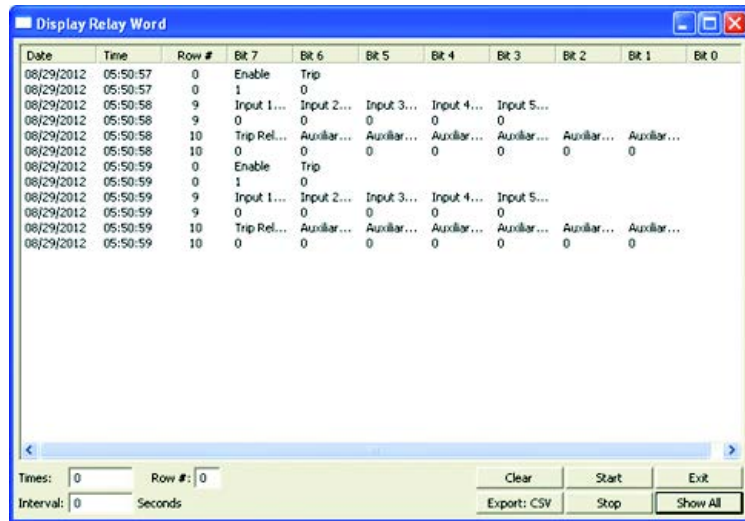

Dialog buttons function as follows:

Start: Begin data collection based on the contents of the **Times** and **Interval** boxes

Times	Interval	Action
Empty	Empty	Poll Row # as fast as possible until Stop button is clicked
Empty	Number	Poll Row # at every time interval until Stop button is clicked
Number	Empty	Poll Row # as fast as possible until Times number of sets have been acquired
Number	Number	Poll Row # at every time interval until Times number of sets have been acquired

Stop: Stop collecting data at any time

Show all: Display every row sequentially one time

Clear: Clear the list contents on the screen

Exit: Hide the data acquisition screen. If data is being acquired via the Start button, it will stop automatically when the window is hidden.

Export CSV: Export the data in the list to a Comma Separated Value file (.csv) for external analysis. If rows are selected a prompt will be displayed asking to save all rows or just the selection.

NOTE: To conserve program memory, only the last 500 rows will be displayed on the screen at a time. All data will be placed into a temporary file.

Data Visualization/Trending



MPS Data Visualization and Trending allow the user to configure the display with specific metering data as well as Relay Word Bits that are then mapped to graphs, gauges and bit indicators so that parameters can be monitored visually. Each indicator auto scales to provide the best fit for the data for easy viewing. The MPS Trending window is independent of the main application window, which allows the user to switch back and forth without closing a window. The user can display:

- Current (Average Magnitude, Average Line, Angle, Imbalance)
- Voltage (Angle, Imbalance, Magnitude)
- Frequency
- Ground Fault Current (Core Balance, Residual)
- Motor Load
- Power (Apparent, Reactive, Real, Power Factor)
- Temperature (Ambient, Bearing Rise, Winding, Thermal Capacity Used)
- Input states
- Auxiliary relay states
- Trip conditions

The parameters can be mapped to a specific bit, gauge or graph assignment. The Data Acquisition Settings dialog window has tabs along the top that can be selected and configured. To assign a parameter a specific location and display form, select a parameter from the Data Available column (left column) as well as a unassigned location from the Assignment column (right column). When

both are highlighted, use the arrow located in the middle to move the parameter to its assignment.

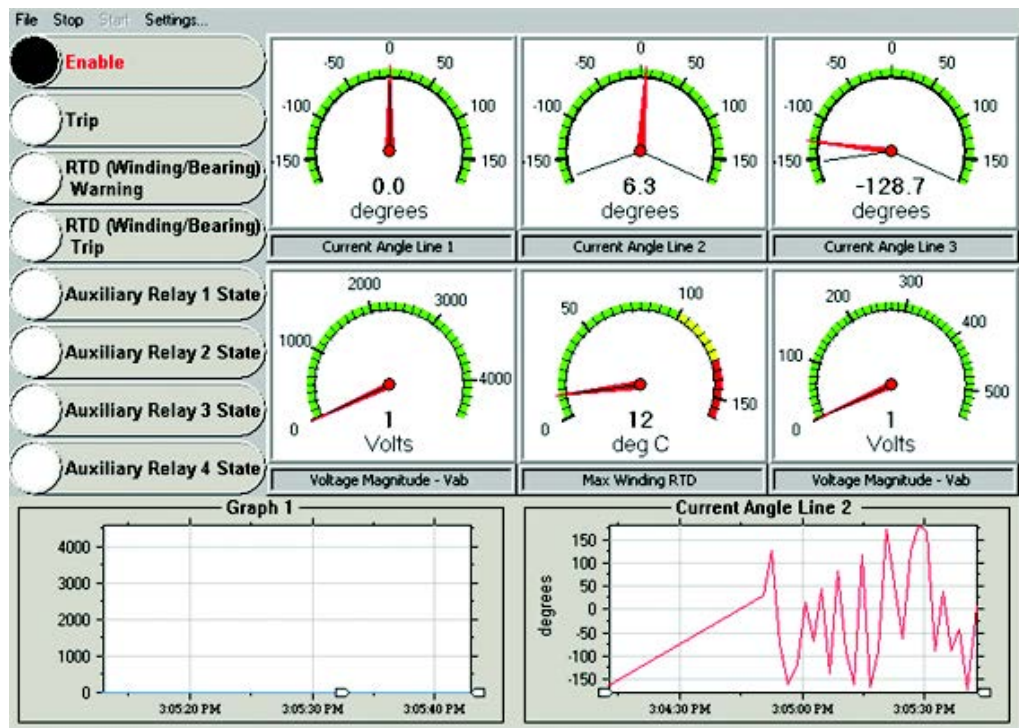
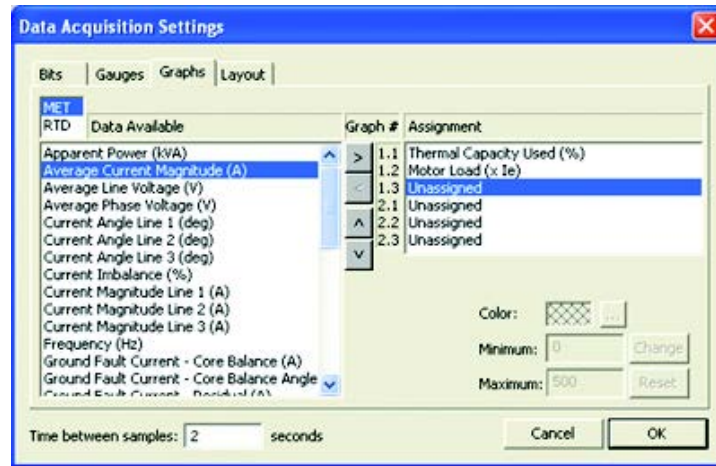

The Data Acquisition Settings also allows the user to map specific hardware data to indicators that are displayed on the screen. The control type can be changed via the Bits, Gauges and Graphs tab along the top of the window. The Layout tab, shown below, can be used to view the correlation between control numbers and their position on the main trending window.

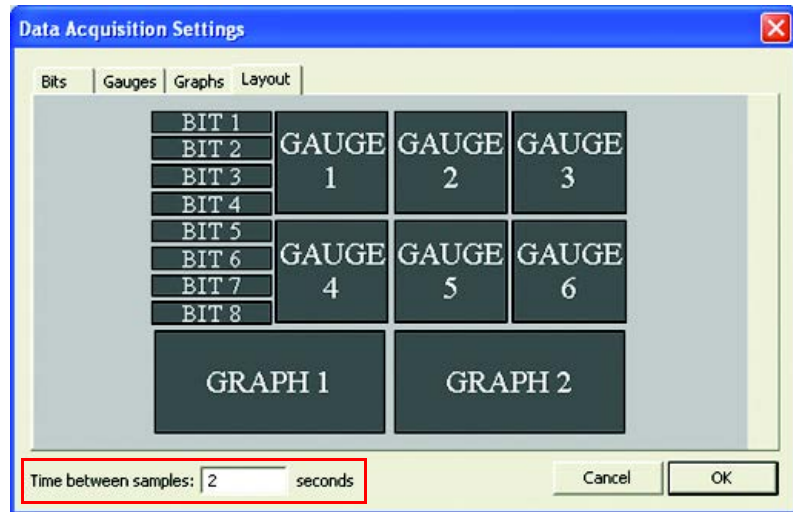

The time between samples can be changed within this window. It can be decreased to allow for a more accurate representation of the monitored event or increased to reduce space if metering for a long period of time. NOTE: The sampling time will be affected by the current serial port speed setting and other factors of latency involved in serial communications. Collecting TAR, MET, and RTD data simultaneously will have a higher minimum acquire time than collecting only one or two of the parameters separately. By default, MPS Explorer uses a minimum half-second acquire time, but in most applications this should be higher to minimize data loss.

Validate Settings

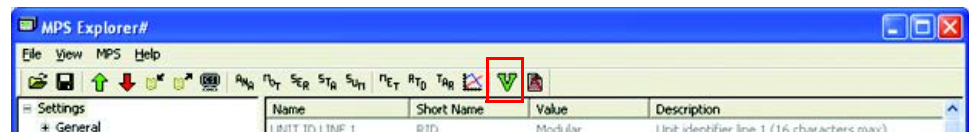

The validate settings dialog quickly checks the device settings and will catch errors or inconsistencies when the parameter settings do not match the hardware settings or capabilities. The validation can be done manually by clicking the highlighted button, or automatically before a settings download takes place.

A list of possible errors will appear showing the name and problem that may contribute to an error.

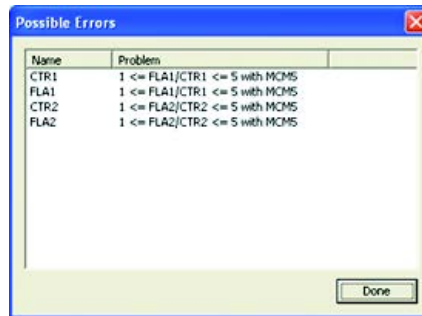

I/O Mapping

MPS Explorer allows the user to easily configure the I/O Map to assign protection trip functions to the Trip relay, assign functions to the auxiliary relay and assign functions to the selected input.

When connected to the device, the user can select I/O Mapping from the Settings tree as shown.

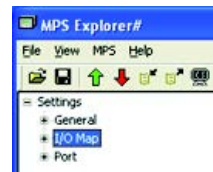

Then, a list of the Trip, Auxiliary Relays and Inputs will be displayed for configuration. Once the list is displayed, the user can locate a specific Trip, Auxiliary or Input to modify. Double-click on a name to open the dialog box that will display each available bit with a corresponding parameter. To enable a bit, click the check box, and then click **Save**.

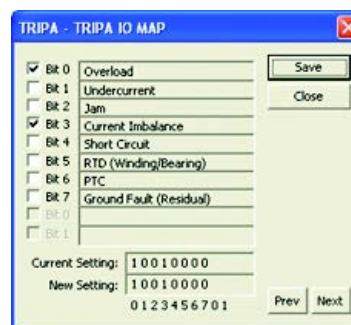

Resetting/Restoring

Restoring Parameter Values

Software: Navigate to **MPS > Parameters > Open Default Settings** to restore the default program settings or the settings in the specified file. The hardware settings will not be restored until the settings are downloaded to the device.

Hardware: Navigate to **MPS > Commands > Restore Defaults** to restore the hardware factory defaults. This option will immediately restore the hardware parameter values and perform a hardware reboot. After the reboot is complete, the software must be reconnected manually. Performing this action will alter the state of the relay and should not be performed while the relay is being used in an application.

Hardware Reboot

Navigate to **MPS > Commands > Reboot Relay** to initiate a hardware reboot that will clear the hardware self-test status. This action will change the state of the relay and should not be performed while it is being used in an application.

Troubleshooting

Problem: MPS Explorer does not detect the presence of the hardware, even when the auto-detect option is used.

Solution:

- Ensure the correct serial port is selected in the Communications Settings window
- Make sure the serial cable is physically and securely connected to the computer and relay.
- Close all other applications that may be attempting to access the serial port.

Problem: A hard copy of the parameters and their current values is desired.

Solution: Save the parameters to a file and open that file in any text editor. With the text editor, the file can be printed as any normal text file. Be careful not to modify the text if the file will be loaded into the MPS Explorer again.

Problem: The Start button has been pressed in the Trending window, but the indicators are not updating.

Solution: Not all of the data available in the Trending Settings dialog is available from the hardware at all times. Hardware and parameter settings will dictate which data is currently being acquired. To verify whether the data is available Start the Trending and open the corresponding MET, RTD or TAR window to observe the data that is available there.

Problem: The date and/or time is wrong in the metering and trending screens.

Solution: The date/time displayed on these screens is the date/time set in the hardware. To change this time use the Date/Time dialog.

Configuring Protection & Logic Functions

Overview

This chapter describes configuring the 825-P relay settings for motor protection, basic functions, I/O mapping, and communications.

NOTE: Each 825-P is shipped with default factory settings. Calculate the settings for your motor to ensure secure, dependable protection.

This chapter includes the following subsections:

- Application Data – information that is required about the protected motor before calculating the relay settings
- Main Settings – settings that configure the relay inputs to accurately measure and interpret the AC current and optional voltage input signals
- Basic Motor Protection – settings for protection elements included in all models of the 825-P, including the thermal element, overcurrent elements, load-loss functions, and load-jam functions
- RTD-Based Protection – settings associated with the RTD inputs (requires RTD Scanner Module)
- Voltage-Based Protection (Relays With Voltage Inputs) – settings associated with the optional AC voltage-based protection elements
- I/O Configuration – settings for the front-panel display control, control inputs/outputs, and analog output for all relay models
- Serial Port Settings – settings that configure the relay front and rear panel serial ports
- DeviceNet Port Settings – settings that configure the relay rear panel DeviceNet port
- Select Relay Logic Diagrams – selected logic diagrams for protection, control, and outputs

Application Data

Calculate the settings for the 825-P by collecting the following information before you begin (collect the information for each speed for two-speed motor applications):

- Specifications of the protected motor:
 - Rated full load current
 - Service factor
 - Locked rotor current
 - Maximum locked rotor time with the motor at ambient and/or operating temperature
 - Maximum motor starts per hour
 - Minimum time between motor starts
- Additional data regarding the motor application:
 - Minimum no load current or power, if known.
 - Motor accelerating time. This is the normal time required for the motor to reach full speed.
 - Maximum time to reach motor full load.

NOTE: This time could be significantly longer than the motor accelerating time, particularly in pump motor applications where the motor could run at full speed for some time before the pump reaches full head and full load.

- Current transformer primary and secondary ratings, if used
- System phase rotation and nominal frequency
- Voltage transformer ratios and connections, if used
- Type and location of resistance temperature devices (RTDs), if used
- Expected fault current magnitudes for motor or cable ground and three-phase faults

Main Settings

Identifier Settings

All models of the 825-P have the identifier settings described in Table 7.

Table 7 - Identifier Settings

Setting Prompt	Setting Range	Factory Default
UNIT ID LINE 1	16 Characters	825-P Modular
UNIT ID LINE 2	16 Characters	Prot. System

The 825-P prints the Relay and Terminal Identifier strings at the top of responses to serial port commands to identify messages from individual relays. Enter up to 16 characters, including capital letters A...Z, numbers 0...9, periods (.), dashes (-), and spaces. Suggested identifiers include the location, process, circuit, size, or equipment number of the protected motor.

Phase Rotation, Nominal Frequency Settings

Table 8 - Phase Rotation, Nominal Frequency Settings

Setting Prompt	Setting Range	Factory Default
PHASE ROTATION	ABC, ACB	ABC
RATED FREQUENCY	50, 60 Hz	60
DATE FORMAT	MDY, YMD, DMY	MDY

The phase rotation setting tells the relay your phase labeling standard. Set Phase Rotation equal to ABC when B-phase current lags A-phase current by 120°. Set Phase Rotation equal to ACB when B-phase current leads A-phase current by 120°.

The thermal overload algorithm is dependent on the proper phase rotation setting. An improper phase rotation will cause nuisance tripping.

Figure 28 - Phase Rotation Setting

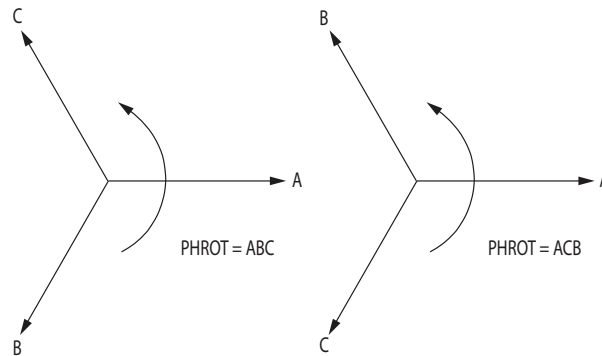

Set the Rated Freq. equal to your system nominal frequency.

Date Format

The Date Format setting allows you to change the relay date presentation format to either North American standard (Month/Day/Year), engineering standard (Year/Month/Day), or European standard (Day/Month/Year).

Current Transformer (CT) Configuration, Full Load Current Settings

Table 9 - CT Configuration and Full Load Current Settings

Setting Prompt	Setting Range	Factory Default
PHASE CT RATIO	1...5000	1
MOTOR FLA (I_e)	0.5...5000 A	0.5
TWO SPEED ENABLE	Y, N	N
CT RATIO-2nd	1...5000	1
MOTOR FLA-2nd	0.5...5000 A	0.5
CORE B. CT RATIO	1...2000	100

Note the following:

- Motor FLA settings are in Primary Amperes.
- The allowed setting range is dependent on the MCM module that is connected to the relay. The MOTOR FLA and PHASE CT RATIO setting ranges will be a subset of the full ranges shown in Table 9.
- When Two Speed Enable = Y and a Speed 2 control input is specified, the relay uses CT Ratio-2nd and Motor FLA-2nd for the overload thermal model.
- CTs with a 1 or 5 A rated secondary current can be used with the Converter Module MCM2, MCM5 or MCM20, respectively. If another MCM module is used, the relay automatically sets CT Ratios = 1.

The CT ratio and full-load current settings, along with the connected MCM module, configure the relay to accurately scale measured values and report the primary quantities. Calculate the phase and neutral CT ratios by dividing the primary rating by the secondary rating.

The relay runs interdependency checks on the FLA and CT ratios based upon the ratings of the MCM module that is connected. If a value is set that violates the interdependency rules, then the user will be prompted to adjust settings to eliminate conflicts.

EXAMPLE Phase CT Ratio Setting Calculation:

Consider an application where
Phase CT Rating=100:5A.
Set the CT Ratio =100/5 := 20

Voltage Transformer (VT) Configuration Settings

Relays that are not equipped with phase voltage inputs will hide these settings and disable voltage-based protection and metering functions.

Table 10 shows voltage settings for relay models with optional voltage inputs.

Table 10 - CT Configuration and Full Load Current Settings

Setting Prompt	Setting Range	Factory Default
PHASE VT RATIO	1...250	34.65
LINE VOLTAGE	100...30000V	4160
XFMR CONNECTION	Delta	Wye Delta

NOTE: The line voltage setting is in primary volts.

These settings configure the optional relay voltage inputs to correctly measure and scale the voltage signals. Calculate the Phase VT Ratio by dividing the primary rating by the secondary rating.

EXAMPLE **Phase VT Ratio Setting Calculation:**

Consider a Phase VT Ratio Setting calculation, consider a 4000V motor application where 4200:120V rated voltage transformers (connected in open delta) are used.

Set the VT Ratio := $4200/120 := 35$ and DELTA_Y := Delta

When phase-to-phase PTs are connected to the relay, set XFMR Connection equal to Delta. When phase-to-neutral PTs are connected to the relay, set XFMR Connection equal to Wye.

Basic Motor Protection

IMPORTANT Settings associated with options or accessories (converter module, voltage input card, expansion I/O card, RTD scanner) require their installation or connection prior to being made available for configuration.



ATTENTION: Configuration of protection elements is not complete until the elements are assigned to the trip or auxiliary relays. Refer to I/O Assignments for instructions.

Overload (Thermal Model)

The 825-P motor thermal element provides integrated protection for all of the following motor operating conditions:

- Locked rotor starts
- Running overload
- Imbalance current/negative-sequence current heating
- Repeated or frequent starting

NOTE: You can set the Run State Time Constant of the thermal overload curve. If the Run State Time Constant is not known, set it to Auto; the relay configures the overload curve continuous with the locked rotor curve.

When overload protection is enabled, the relay configures a thermal curve based on the motor Full Load Amps, Service Factor, Locked Rotor Amps, Hot Locked Rotor Time, and Acceleration Factor settings. See Figure 32 for selected settings of Thermal Overload curves.

The relay operates a thermal model with a trip value defined by the relay settings and a present heat estimate that varies with time and changing motor current. The relay expresses the present motor thermal estimate as % Thermal Capacity. When the % Thermal Capacity reaches 100%, the relay trips.

If the thermal model is turned off (Overload Enable := N), the thermal model is disabled, the output of the thermal model is blocked, and the relay reports the % Thermal Capacity as 999 as noted in Chapter 7: Metering & Monitoring.

Table 11 - Overload (Thermal Model) Settings

Setting Prompt	Setting Range	Factory Default
OVERLOAD ENABLE	Y, N	Y
OL RESET MODE	Man, Auto	Man
OL RESET LEVEL	10...99%TCU	75
SERVICE FACTOR	1.01...1.50	1.01
MOTOR LRC	2.5...12.0 x I_e	6.0
LOCKD ROTOR TIME	1.0...600.0 s	10.0
ACCEL FACTOR	0.10...1.50	1.00
RUN STATE TIME K	Auto, 1...2000 min	Auto
MOTOR LRC-2nd	2.5...12.0 x I_e	6.0
MOTOR LRT-2nd	1.0...600.0 s	10.0
ACCEL FACT-2nd	0.10...1.50	1.00
RUN ST TC-2nd	Auto, 1...2000 min	Auto
OL WARN LEVEL	Off, 50...99%TCU	85
START INH. LEVEL	Off, 1...99%TCU	Off
STOP COOL TIME	1...2200 min	18
OL RTD BIASING	Y, N	N

IMPORTANT For compliance to IEC standards regarding thermal overload protection, set the SERVICE FACTOR to a value: 1.05...1.20.

When you enable overload protection, the relay requests information about the protected motor capabilities. Obtain the requested information (except the acceleration factor) from the motor specifications.

The 825-P thermal element always operates in one of two modes: starting or running. In starting mode, the thermal element trips in Locked Rotor Time at Locked Rotor Current whether the motor is at ambient or at normal operating temperature. In running mode, the thermal element provides overload protection by limiting the motor heat energy estimate to a value represented by the overload settings.

The locked rotor time setting is for a hot motor condition. If only one locked rotor time is specified for a particular motor, unless the specification states otherwise, assume the time is the cold locked rotor time. Multiply the cold locked rotor time by 0.833 to determine a hot locked rotor time which is acceptable for most motors.

NOTE: When Two Speed Enable = Y and a Speed 2 control input is specified, the relay uses the "2nd" FLA-related settings for the overload thermal model

EXAMPLE Thermal Element Setting

A 4000V 600 Hp motor is protected using the 825-P Thermal Overload Element. Motor data sheet includes the following:

- Rated Horsepower = 600 Hp
- Rated Voltage = 4000V
- Rated Full Load Current = 80 A
- Rated Locked Rotor Amps = 480 A
- Safe Stall Time at 100% Volts:
 - Cold = 18 seconds
 - Hot = 15 seconds
- Service Factor = 1.2

Phase current transformers with 100:5 A rating and the MCM20 module are selected for application. 825-P settings for application are calculated as shown below:

- Current Transformer Ratio: := 100/5 := 20
- Full Load Amps (Ie): := 80 A primary
- Service Factor: := 1.2
- Locked Rotor Amps: := 480.0/80.0 := 6.0 x Ie
- Hot Locked Rotor Time: := 15.0 seconds
- Run state time constant: := Auto

NOTE: To prevent nuisance tripping from occurring when a motor operates at the rated service factor, set Service Factor to 0.01 plus the motor nameplate value.

If the Locked Rotor Ampere rating for the motor is unknown, but the motor has a Motor Code designation, use the following table as provided by NEMA (National Electrical Manufacturer Association) to determine the locked rotor ampere value.

Table 12 - Motor Codes

Letter Designation	kVA/HP ❶	Letter Designation	kVA/HP ❶
A	0...3.15	L	9.0...10.0
B	3.15...3.55	M	10.0...11.2
C	3.55...4.0	N	11.2...12.5
D	4.0...4.5	P	12.5...14.0
E	4.5...5.0	R	14.0...16.0
F	5.0...5.6	S	16.0...18.0
G	5.6...6.3	T	18.0...20.0
H	6.3...7.1	U	20.0...22.4
J	7.1...8.0	V	22.4 and up
K	8.0...9.0		

❶ Locked kVA per horsepower range includes the lower figure up to, but not including, the higher figure; e.g., 3.14 is designated by letter A and 3.15 is designated by letter B.

The Acceleration Factor setting reduces or extends the allowed accelerating time under locked rotor conditions. You can always safely set this value equal to 1.00.

If you know that the driven load always accelerates in less than the rated locked rotor time, you could use an acceleration factor less than 1.00 to provide a faster trip in locked rotor conditions. Do not, however, set the value greater than 1.00, except to allow a start with a longer than normal accelerating time (e.g., high inertia motor application, emergency condition).

Acceleration Factor Setting Calculation:

EXAMPLE	In a particular application, a motor with a 10 second hot-locked rotor time always starts in 5 seconds.
	Setting the acceleration factor equal to 0.75 causes the relay to trip in 7.5 seconds under locked rotor conditions. This setting allows ample time for the motor to start, but does not subject the motor to the full 10 seconds of locked rotor current if a locked rotor start attempt takes place.

When the motor thermal capacity used exceeds the Overload Warning Level setting, the relay issues a warning. The early warning could allow you to correct the load problem before a thermal trip occurs.

The motor tripping and starting functions include supervision to help prevent a thermal trip on a normal start. The relay prevents motor starting until the thermal element has enough available thermal capacity to allow a motor start without tripping. Set START INH. LEVEL to a value equal to the incremental increase in percent thermal capacity utilized for one start plus additional margin. The 825-P allows a new start when the percent thermal capacity utilized value is below 100 - START INH. LEVEL. This feature can be disabled by setting START INH. LEVEL equal to Off.

A stopped motor could take longer to cool than a running motor because of reduced airflow or loss of forced coolant. The equation used is:

$$\text{COOLTIME} = 0.03 \cdot k \cdot \text{LRTHOTn} \cdot (\text{LRAn}) \text{ 2 minutes}$$

where:

n = 1 or 2 (select the one that gives higher COOLTIME)

k > 1.0

Round up the result to the next integer. The value k = 1.0 yields stop cool time equal to run cool time.

The factory default settings assume that the motor stopped cooling time is approximately the same as the motor running cooling time. Calculate the STOP COOL TIME setting for your application using the value that you want for k > 1.0.

Motor running and stopped cooling times or time constants could be provided by the motor manufacturer. If a time constant is provided, multiply that value by 3 to calculate the STOP COOL TIME setting.

OL RESET MODE determines the reset mode for the overload element. If set to Auto, the overload trip resets automatically when the element resets, provided no other trip conditions are present. If set to Manual, operator intervention is required to reset the overload trip.

OL RESET LEVEL determines the Thermal Capacity Utilized (%TCU) Level below which the relay allows Reset (Automatic or Manual) following an overload trip.

You can bypass the Thermal Model by ambient temperature when OL RTD BIASING is set equal to Y. The Overload RTD Bias is calculated using the ambient temperature above 40°C and Winding RTD Trip temperature setting.

NOTE: In addition to setting OL RTD BIASING := Y, you must set one RTD Location equal to Ambient, at least one RTD Location equal to Winding, and set the Winding Trip Level (see Table 27 for details).

Short Circuit

Table 13 - Short Circuit Settings

Setting Prompt	Setting Range	Factory Default
SC TRIP LEVEL	Off, 4.00...12.00 x I_e	Off
SC TRIP DELAY	0.00...5.00 s	0.00
SC WARN LEVEL	Off, 4.00...12.00 x I_e	Off
SC WARN DELAY	0.00...5.00 s	0.50

If the 825-P is connected to a motor protected by a fused contactor, disable the short circuit element by setting its Trip level to Off. If the relay is connected to a device capable of interrupting fault current, use the element to detect and trip for short circuit faults. Set the Short Circuit Trip Level to a value greater than the motor locked rotor current rating. Set the Short Circuit Warn Level to the value that you want with appropriate time delay.

NOTE: The 825-P short circuit elements normally operate using the output of a cosine filter algorithm. During heavy fault currents when the relay detects severe MCM/CT saturation the overcurrent elements operate on the output of a bipolar peak detector.

Based on the level of an harmonic distortion index, the short circuit overcurrent elements operate on either the output of the cosine filter or the output of the bipolar peak detector. When the harmonic distortion index exceeds the fixed threshold that indicates severe MCM/CT saturation, the short circuit overcurrent elements operate on the output of the bipolar peak detector.

When the harmonic distortion index is below the fixed threshold, the short circuit overcurrent elements operate on the output of the cosine filter.

The cosine filter provides excellent performance in removing DC offset and harmonics. However, the bipolar peak detector has the best performance in situations of severe MCM/CT saturation when the cosine filter magnitude estimation is significantly degraded. Combining the two filters ensures dependable short circuit overcurrent element operation.

Ground Fault

Basic Information

Table 14 - Ground-Fault Core Balance Settings

Setting Prompt	Setting Range	Factory Default
GF-CB TRIP LEVEL	Off, 0.01...25.00 A	Off
GF-CB TRIP DELAY	0.00...5.00 s	0.00
GF-CB WARN LEVEL	Off, 0.01...25.00 A	Off
GF-CB WARN DELAY	0.0...120.0 s	10.0

NOTE: GF-CB Trip Level settings are in Primary Amperes.

The relay offers two types of ground-fault detecting elements. The CB elements operate using current measured through an external core balance (zero sequence) CT. The residual (RES) elements operate using a residual ground-fault measurement from the MCM module.

While the ground-fault trip and warning levels offer an overall range of 0.01...25 A, the actual input circuitry has a dynamic sensing range of 5...500 mA. Determine the range (in terms of primary amps) that is valid for a given application by multiplying the input sensing range of 5...500 mA by the turns ratio of the core balance sensor.

For information about corresponding valid ground fault setting ranges for typical sensors, see Table 15.

Table 15 - Ground-Fault Sensor-to-Settings Correlation

Ground Fault Sensor Ratio	Valid Setting Range
1:1	0.01...0.50 A
50:5	0.10...5.00 A
100:1	1.00...25.00 A
2000:1	20.00...25.00

When a ground-fault CT is connected to the 825-P, as in Figure 14, use the CB ground-fault element to detect motor ground faults. Calculate the Trip and Warn level settings based on the available ground fault current and the CB CT ratio.

EXAMPLE Ground-Fault CB CT Application

A resistance-grounded transformer limits current for motor or cable ground faults. The resistor is sized to limit current to 10 A primary. The three motor leads are passed through the window of a 10:1 core balance CT. The CT secondary is connected to 825-P CBCT input terminals, as shown in Figure 29. Setting the core balance CT Ratio equal to 10 and Ground Fault Trip Level equal to 5 A with 0.10 second time delay ensures that the element quickly detects and trips for motor ground faults, but prevents faulty operation due to unequal breaker or contactor pole closing times.

Figure 29 - Ground-Fault Protection Using Core Balance CT

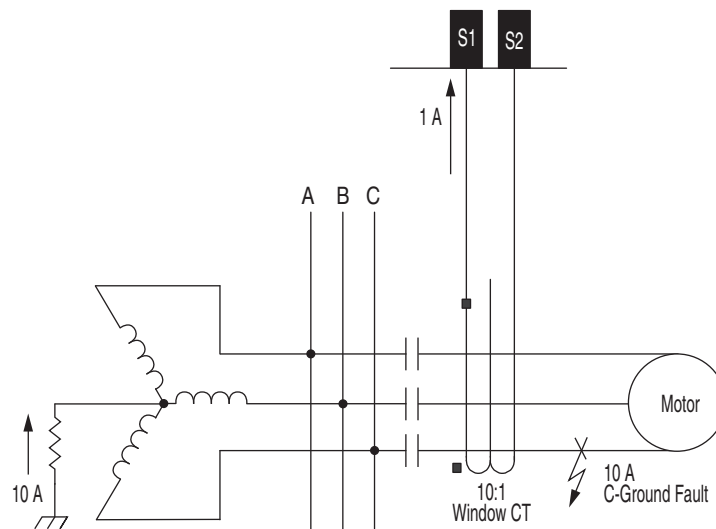

Table 16 - Ground-Fault Residual Settings

Setting Prompt	Setting Range	Factory Default
GF-RES TRIP LEVEL	Off, 0.10... 1.00 x I_e	Off
GF-RES TRIP DLAY	0.00... 5.00 s	0.50
GF-RES WARN LEVEL	Off, 0.10... 1.00 x I_e	Off
GF-RES WARN DLAY	0.0... 120.0 s	10.0

NOTE: Phase CT ratios are typically higher than CB CT ratios. For this reason, the relay sensitivity to motor ground faults is less when the residual overcurrent element is used instead of the CB element. A separate ground fault detection method should be used if a CB CT is not available in applications where resistance grounding reduces the available ground fault current.

For solidly grounded systems, the residual ground fault elements can be used.

Jam

Table 17 - Jam Settings

Setting Prompt	Setting Range	Factory Default
JAM TRIP LEVEL	Off, 1.00...6.00 x I_e	Off
JAM TRIP DELAY	0.0...120.0 s	5.0
JAM WARN LEVEL	Off, 1.00...6.00 x I_e	Off
JAM WARN DELAY	0.0...120.0 s	10.0

When the motor is running, the relay offers jam detection. When the motor load jams (stalling the motor), the phase current increases to near the locked rotor value. When Load Jam Tripping is enabled, if the phase current exceeds the Load Jam Trip Level setting for longer than the time delay setting, the relay trips. Set the Load Jam Trip Level greater than the expected normal load current but less than the rated locked rotor current. This setting is entered in per unit of the Full Load Amps (I_e) setting.

Undercurrent (Load Loss)

Table 18 - Undercurrent Settings

Setting Prompt	Setting Range	Factory Default
UC TRIP LEVEL	Off, 0.10...1.00 x I_e	Off
UC TRIP DELAY	0.0...120.0 s	5.0
UC WARN LEVEL	Off, 0.10...1.00 x I_e	Off
UC WARN DELAY	0.0...120.0 s	10.0
UC START INHIBIT	0...1500 s	0

The relay arms the load-loss detection logic after the motor starts, as defined by the Undercurrent Start Inhibit time delay setting. Set this delay to allow pumps or compressors to reach normal load. Once armed, this function issues a warning or trip if phase current drops below warn or trip level for the specified time delay.

Set the Undercurrent Trip and Warn Levels greater than the expected motor no load current, but less than the minimum current expected when the motor is operating normally. These settings are entered in per unit of the Full Load Amps (I_e) setting.

If you expect the motor to normally operate at no load, disable the Trip and Warn elements. The relay automatically hides the associated time delay settings.

Current Imbalance/ Phase Loss

Table 19 - Current Imbalance Settings

Setting Prompt	Setting Range	Factory Default
CI TRIP LEVEL	Off, 5...80%	Off
CI TRIP DELAY	0...240 s	5
CI WARN LEVEL	Off, 5...80%	10
CI WARN DELAY	0...240 s	10

Imbalanced motor terminal voltages cause imbalanced stator currents to flow in the motor. The negative-sequence current component of the imbalance current causes significant rotor heating. While the 825-P motor thermal element models the heating effect of the negative-sequence current, you could want the additional imbalance and single-phasing protection offered by a current imbalance element.

The 825-P calculates percent imbalance current in one of two ways, depending on the magnitude of the average current.

When the average current, I_{av} , is:

- greater than** the motor-rated full load current, the relay calculates the percent imbalance:

$$UB\% = 100 \times \frac{[(I_m - I_{av})]}{I_{av}}$$

- less than** the motor-rated full load current, the relay calculates the percent imbalance:

$$UB\% = 100 \times \frac{[(I_m - I_{av})]}{FLA}$$

where:

- UB% = current imbalance percentage
- I_m = magnitude of phase current with largest deviation from average
- I_{av} = magnitude of the average phase current
- FLA = motor-rated full load current

In either case, the function is disabled if the average phase current magnitude is less than 25% of the Full Load Amps setting.

A 1% voltage imbalance typically causes approximately 6% current imbalance in induction motors. If a 2% voltage imbalance can occur in your location, set the current imbalance Warn Level greater than 12% to prevent nuisance alarms. A 15% current imbalance Warn Level setting corresponds to an approximately 2.5% voltage imbalance, and a 20% current imbalance trip setting corresponds to an approximately 3.3% voltage imbalance. A 10-second alarm delay and 5-second trip delay should provide adequate performance in most applications.

Protection Disable

Table 20 - Protection Disable Settings

Setting Prompt	Setting Range	Factory Default
PROT INHIBIT TIME	Off, 1...240 s	Off
OL INHIBIT TIME	Off, 1...240 s	Off



ATTENTION: The protection can be seriously jeopardized when either of the Inhibit Time settings is used. For most applications, set the value of PROT INHIBIT TIME and OL INHIBIT TIME to Off.

You can disable Trip and Warning levels of preselected protection elements for a set time delay during motor Starting. Set the Protection Inhibit Time for a delay to disable Undercurrent, Short Circuit, Current Imbalance, Ground Fault, and Undervoltage elements. Set the Overload Inhibit Time for a delay to disable the Overload (Thermal Model) element. If you are using the time delay settings, keep them as short as possible.

NOTE: The 825-P determines the motor state (Starting, Running, or Stopped) primarily based on the motor current.

Start Monitoring

Table 21 - Start Monitor Settings

Setting Prompt	Setting Range	Factory Default
START MOTOR TIME	Off, 1...240 s	Off

NOTE: With Star-Delta (Wye-Delta) starting, the total starting time (Star and Delta) is monitored. If immediate tripping is required in the event of stalling, monitoring must be provided by a Speed Switch Function.

If motor starting has not finished by the set time, the relay produces a trip. The start monitoring is independent of the overload protection provided by the thermal model. Figure 30 shows the typical current during motor start and the Start Motor Time setting.

Figure 30 - Monitoring Starting Time

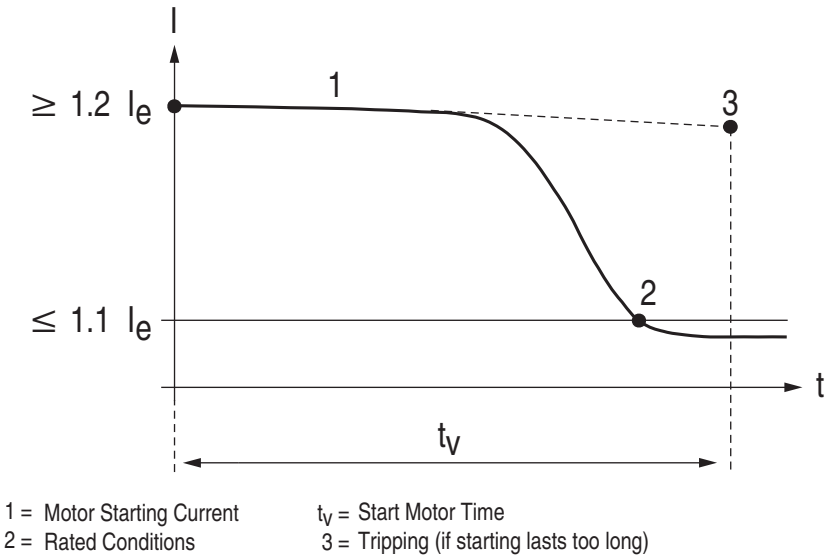

Star-Delta (Wye-Delta) Starting

Table 22 - Star-Delta Settings

Setting Prompt	Setting Range	Factory Default
STAR-DELTA ENABL	Y, N	N
MAX STAR TIME	Off, 1...600 s	Off

NOTE: In addition to enabling the Star-Delta, you must assign Star and Delta to Auxiliary output relays (one each).

The 825-P issues the command to switch from Star to Delta (Wye to Delta) as soon as the starting current has dropped to the rated value and the motor has reached its normal speed in Star (Wye). If starting has not been completed within the normal time for this application (Max Star Time setting, if used), the relay makes the change to delta, regardless of the speed attained.

You can switch the maximum permissible time for star (wye) operation on or off. If it is off, the change to delta is made solely based on the motor current. If the motor has to be switched off when the total start time (Star and Delta) exceeds a set time, the Start Monitoring must also be used.

Start Inhibit

Table 23 - Start Inhibit Settings

Setting Prompt	Setting Range	Factory Default
STARTS/HR.	Off, 1...15	Off
MIN. OFF TIME	Off, 1...150 min	Off
RESTART BLK TIME	Off, 1...60 min	Off

When the protected motor is rated for a specific maximum number of starts per hour or minimum time between starts, set the Starts/Hr. and Min. Off Time settings accordingly. If the maximum number of starts per hour is achieved and the motor stops or is tripped, the relay asserts the Trip output contact to prevent an additional start until 60 minutes after the oldest start. If the motor stops or is tripped within the minimum time between starts period, the relay asserts the Trip output contact to prevent a new start until the minutes after the most recent start equals the Min. Off Time setting.

In certain pump applications, fluid flowing backward through the pump could spin the pump motor for a short time in the reverse direction after the motor is stopped. An attempt to start the motor during this time can be damaging. To prevent motor starts during the backspin period, enter a time in minutes in the RESTART BLK TIME setting. If the relay trips or the motor is stopped, the relay generates a trip signal and maintain it for at least this amount of time. The relay does not issue a start during the Restart Block period.

The relay maintains the trip signal until enough time passes for the motor to be safely restarted. During the lockout period, the relay displays a countdown time in minutes to the next allowed start.

The Emergency Restart function overrides all three limits, clearing % TCU to zero and allowing the motor to be put back in service for an emergency.

Phase Reversal Protection

Table 24 - Phase Reversal Setting

Setting Prompt	Setting Range	Factory Default
PH REV. ENABLE	Y,N	N

The 825-P uses phase currents or phase voltages (if available) to determine that the phase rotation of signals applied to the relay matches the phase rotation setting. When you set Ph. Rev. Enable equal to Y, the relay trips 0.5 seconds after incorrect phase rotation signals are applied to the relay.

For relays equipped with current inputs only, the trip occurs approximately 0.5 seconds after the motor start is initiated. When the relay is equipped with voltage inputs, the trip occurs approximately 0.5 seconds after AC voltages are applied to the relay.

Speed Switch (Stalling During Start)

Table 25 - Speed Switch Settings

Setting Prompt	Setting Range	Factory Default
SS TRIP DELAY	Off, 1...240 s	Off
SS WARN DELAY	Off, 1...240 s	Off

NOTE: In addition to setting the SS DELAY, you must connect the speed switch contact to an input assigned to Speed Switch (see Table 44 and Figure 5, Figure 20, and Figure 21 for connection diagrams).

Speed Switch (stalling during start) protection provides mechanical sensing of a locked rotor condition through input monitoring of a speed switch that is mechanically coupled to the motor shaft. When the SS TRIP DELAY is set, the relay trips if the speed switch is not closed within the set time after the motor start begins. A separate delay, SS WARN DELAY, can also be set to provide a warning before the Speed Switch trip. Figure 31 shows typical currents during motor start (normal and stall during start) and the Speed Switch Trip Delay time setting.

Figure 31 - Stalling During Starting

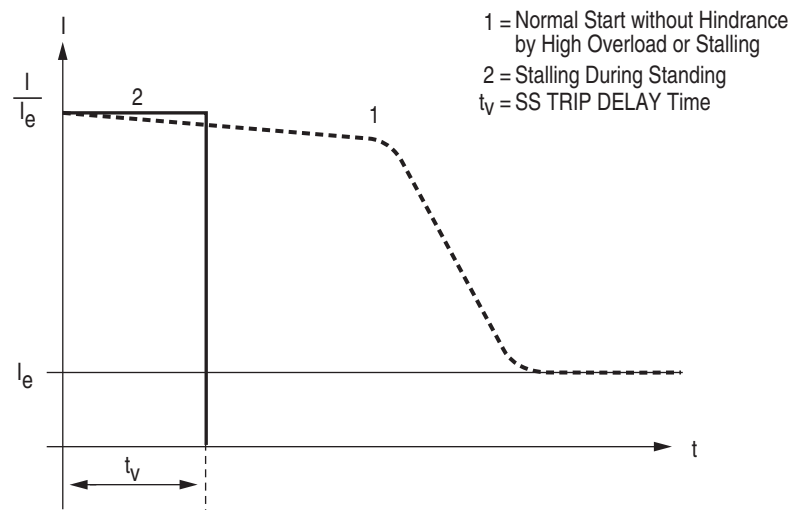

Thermistor (PTC) Monitoring

Table 26 - PTC Settings

Setting Prompt	Setting Range	Factory Default
PTC ENABLE	Y, N	N
PTC RESET MODE	Man, Auto	Man

NOTE: In addition to enabling the PTC function, you must also connect at least one (but no more than six) thermistor(s) to the relay (see Figure XX for a connection diagram).

You can connect up to six PTC thermistor sensors to the 825-P. The detectors are typically embedded in the stator winding of the motor and they monitor the actual temperature of the winding. This function is independent of the thermal model and accounts for conditions such as ambient temperature, obstructed cooling, etc. The sensors and their leads are also monitored for short-circuit faults.

Figure 32 shows characteristics of the PTC. Setting PTC RESET MODE determines reset mode for the PTC element. If set to Auto mode, the PTC trip resets automatically when the element resets, if other trip conditions are not present. If set to Man, operator intervention (e.g., front-panel push button) is required to reset the PTC trip.

Figure 32 - Characteristic of PTC Sensors as per IEC 34-11-2

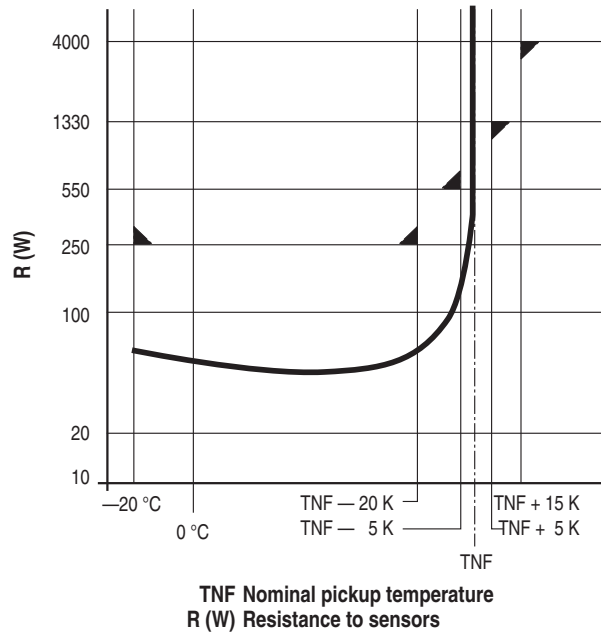

RTD-Based Protection

RTD Monitoring

When you connect the 825-PR12D RTD Module, the 825-P offers several protection and monitoring functions whose settings are described in Table 27. See Figure 4 for the location of the RTD module fiber-optic cable connector.

NOTE: The 825-P can monitor up to 12 RTDs connected to the 825-PR12D Module. Table 27 shows Location, Type, and Trip/Warn Level settings only for RTD1; settings for RTD2 through RTD12 are similar.

NOTE: A fiber optic cable is not included with the 825-PR12D. A simplex 62.5/125 μm fiber-optic cable with ST connector is needed for connecting the 825-PR12D to the 825-P (eg., part# 1570FCBL-MM-SX-62-STST-2M from Ultra Spec Cable - <http://store.ultraspec.us>).

Table 27 - RTD Settings

Setting Prompt	Setting Range	Factory Default
RTD ENABLE	Y, N	N
RTD RESET MODE	Man, Auto	Man
RTD1 LOCATION	Off, WDG, BRG, AMB, OTH	Off
RTD1 TYPE	PT100, NI100, NI120, CU10	PT100
RTD1 TRIP LEVEL	Off, 1...250°C	Off
RTD1 WARN LEVEL	Off, 1...250°C	Off
•	•	•
•	•	•
•	•	•
WIND TRIP VOTING	Y, N	N
BEAR TRIP VOTING	Y, N	N
TMP RTD BIASING?	Y, N	N

When the 825-PR12D Module is not connected to the relay, disable the RTD function by setting RTD ENABLE equal to N.

Setting RTD RESET MODE determines the reset mode for the RTD element. If set to Auto mode, the RTD trip resets automatically when the element resets, provided no other trip conditions are present. If set to Man, operator intervention (e.g., front-panel push button) is required to reset the RTD trip.

The relay allows you to independently define the location of each monitored RTD using the RTD LOCATION settings.

Define the RTD Location settings using the following suggestions:

- If an RTD is not connected to an input, or has failed in place and is not being replaced, set the RTD Location for that input to Off.
- For RTDs embedded in motor stator windings, set the RTD Location equal to WDG.
- For inputs connected to RTDs measuring bearing rise temperature, set the RTD Location equal to BRG.
- For the input connected to an RTD measuring ambient motor cooling air temperature, set the RTD Location equal to AMB. Only one ambient temperature RTD is allowed.
- For inputs connected to monitor temperatures of another apparatus, set the RTD Location equal to OTH.

The relay allows you to independently define the type of each monitored RTD using the RTD Type settings.

If an RTD Location setting is equal to Off, the relay does not request that an RTD Type setting be entered for that input.

The four available RTD types are:

- 100-ohm platinum (PT100)
- 100-ohm nickel (NI100)
- 120-ohm nickel (NI120)
- 10-ohm copper (CU10)

The 825-P provides temperature warnings and trips using the RTD temperature measurements and the warning and trip temperature settings in Table 27.

The relay issues a winding temperature warning if any of the healthy winding RTDs (RTD Location setting equals WDG) indicate a temperature greater than the corresponding RTD Warning Temperature setting. The relay issues a winding temperature trip if one or two of the healthy winding RTDs indicate a temperature greater than their RTD Trip Temperature settings. Two winding RTDs must indicate excessive temperature when the Winding Trip Voting setting equals Y. Only one excessive temperature indication is required if Winding Trip Voting is not enabled. Bearing Trip Voting works similarly.

The warning and trip temperature settings for Bearing, Ambient, and Other RTD types function similarly except that trip voting is not available for Ambient and Other RTDs.

To disable a temperature warning or trip function, set the appropriate temperature setting to Off.

Only healthy RTDs can contribute temperatures to the warning and trip functions. The relay includes specific logic to indicate if RTD leads are shorted or open.

When you have connected an ambient temperature sensing RTD and set trip temperatures for one or more winding RTDs, the relay gives you the option to enable RTD Trip Temperature biasing by setting TMP RTD BIASING equal to Y. The thermal model can also be biased by setting OL RTD BIASING equal to Y (see Table 11) When you enable either of the biasing, the relay does the following:

- Calculates RTD % Thermal Capacity and adds the value to the Thermal Meter values.
- Automatically reduces the winding RTD Trip Temperatures if ambient temperature rises above 40°C and TMP RTD BIASING is set equal to Y.
- Automatically reduces the Thermal Model element trip threshold if ambient temperature rises above 40°C and OL RTD BIASING is set equal to Y.

- Provides an RTD Bias Alarm if the winding temperature exceeds 60°C rise over ambient and the RTD % Thermal Capacity exceeds the thermal element % Thermal Capacity by more than 10%.

EXAMPLE Relay Calculation of RTD% Thermal Capacity

$$\text{RTD\% Thermal Capacity} = \frac{\text{Winding RTD Temperature} - \left(\text{Ambient Temperature} \right)}{\text{Winding RTD Trip Temperature} - \left(\text{Ambient Temperature} \right)}$$

As ambient temperature rises, the motor’s ability to shed heat to the surroundings is reduced and internal temperatures rise. To preserve insulation life, NEMA standards suggest a 1°C reduction in RTD Trip Temperature for each 1°C rise in ambient temperature over 40°C.

When you enable RTD biasing, the 825-P automatically reduces the RTD Trip Temperatures for all winding RTDs when ambient temperature is above 40°C. The relay reduces the trip temperatures by 1°C for each degree rise in ambient temperature over 40°C.

Finally, when you enable Thermal Model biasing, the relay provides an RTD Bias Alarm when the RTD % Thermal Capacity exceeds the thermal element % Thermal Capacity by more than 10 percentage points while the winding temperature rise is higher than 60°C over ambient. This alarm can be a useful indicator that the motor has lost coolant flow or that the winding RTD Trip Temperature is conservatively low.

For all the RTD Thermal Capacity and bias calculations described above, the relay uses the winding RTD whose measured temperature is closest to its trip value.

Voltage-Based Protection

The following information applies to relay models with voltage inputs.

Undervoltage

Table 28 - Undervoltage Settings

Setting Prompt	Setting Range	Factory Default
UV TRIP LEVEL	Off, 0.60...1.00 xVnm	Off
UV TRIP DELAY	0.0...120.0 s	0.0
UV WARN LEVEL	Off, 0.60...1.00 xVnm	Off
UV WARN DELAY	0.0...120.0 s	5.0

Overvoltage

Table 29 - Overvoltage Settings

Setting Prompt	Setting Range	Setting Name := Factory Default
OV TRIP LEVEL	Off, 1.00...1.20 xVnm	Off
OV TRIP DELAY	0.0...120.0 s	0.0
OV WARN LEVEL	Off, 1.00...1.20 xVnm	Off
OV WARN DELAY	0.0...120.0 s	5.0

When you connect the 825-P voltage inputs to phase-to-phase connected PTs, as in Figure 12, the relay provides two levels of phase-to-phase overvoltage and undervoltage elements.

When you connect the 825-P voltage inputs to phase-to-neutral connected PTs, as in Figure 12, the relay provides two levels of phase-to-neutral overvoltage and undervoltage elements.

Each of the elements has an associated time delay. You can use these elements for tripping and warning. To disable an element, set the level setting to Off.

VAR Function

Table 30 - VAR Settings

Setting Prompt	Setting Range	Factory Default
NEG VAR TRIP LEV	Off, 1...25000 KVAR	Off
POS VAR TRIP LEV	Off, 1...25000 KVAR	Off
VAR TRIP DLY	0...240 s	1
NEG VAR WARN LEV	Off, 1...25000 KVAR	Off
POS VAR WARN LEV	Off, 1...25000 KVAR	Off
VAR WARN DLY	0...240 s	1

NOTE: VAR Trip and Warning Level settings are in Primary KVAR.

If the positive or negative reactive power exceeds the appropriate level for longer than the time delay setting, the relay can issue a warning or trip signal. The reactive power elements are disabled when the motor is stopped or starting. Elements can be used to detect synchronous motor out-of-step or loss-of-field conditions.

Refer to Power Measurement Conventions on page 107 for the relay power measurement convention.

For relay application on an induction motor, it is recommended that the installer disable the elements by setting both the Negative VAR Warn Level and Negative VAR Trip Level settings to Off.

Underpower

Table 31 - Underpower Settings

Setting Prompt	Setting Range	Factory Default
UP TRIP LEVEL	Off, 1...25000 kW	Off
UP TRIP DELAY	0...240 s	1
UP WARN LEVEL	Off, 1...25000 kW	Off
UP WARN DELAY	0...240 s	1

NOTE: Underpower Trip and Warning Level settings are in Primary kW.

If the real three-phase power falls below the warning or trip level for longer than the time delay setting, the relay can issue a warning or trip signal. The underpower elements are disabled when the motor is stopped or starting. Underpower elements operate in addition to the Load Loss function and you can use them to detect motor load loss and other underpower conditions.

Disable the elements by setting the Underpower Warning Level and Underpower Trip Level settings to Off.

Power Factor

Table 32 - Power Factor Settings

Setting Prompt	Setting Range	Factory Default
PF LAG TRIP LEV	Off, 0.05...0.99	Off
PF LD TRIP LEV	Off, 0.05...0.99	Off
PF TRIP DELAY	0...240 s	1
PF LAG WARN LEV	Off, 0.05...0.99	Off
PF LD WARN LEV	Off, 0.05...0.99	Off
PF WARN DELAY	0...240 s	1

If the measured power factor falls below the leading or lagging level for longer than the time delay setting, the relay can issue a warning or trip signal. The power factor elements are disabled when the motor is stopped or starting. Power factor elements can be used to detect synchronous motor out-of-step or loss-of-field conditions.

Refer to Power Measurement Conventions on page 107 for the relay power measurement convention.

For application on an induction motor, it is recommended that the installer disable the elements by setting all four Power Factor Level settings to Off.

Frequency

Table 33 - Frequency Settings

Setting Prompt	Setting Range	Factory Default
FREQ1 TRIP LEVEL	Off, 55.0...65.0 Hz	Off
FREQ1 TRIP DELAY	0.0...240.0 s	0.0
FREQ1 WARN LEVEL	Off, 55.0...65.0 Hz	Off
FREQ1 WARN DELAY	0.0...240.0 s	0.0
FREQ2 TRIP LEVEL	Off, 55.0...65.0 Hz	Off
FREQ2 TRIP DELAY	0.0...240.0 s	0.0
FREQ2 WARN LEVEL	Off, 55.0...65.0 Hz	Off
FREQ2 WARN DELAY	0.0...240.0 s	0.0

NOTE: The setting range for Trip and Warn Levels shown in Table 33 are for Rated Freq. := 60 Hz. The setting ranges are "Off, 45.0–55.0 Hz" when Rated Freq. := 50 Hz.

The 825-P provides two warning and two trip overfrequency or underfrequency elements with independent level and time-delay settings. When an element level setting is less than the Nominal Frequency setting, the element operates as an underfrequency element. When the level setting is greater than the Nominal Frequency setting, the element operates as an overfrequency element.

The relay measures system frequency for these elements using the positive sequence voltage if the voltage input option is present. Otherwise, the relay uses positive sequence current.

Load Control Function

Table 34 - Load Control Settings

Setting Prompt	Setting Range	Factory Default
LOAD CONTROL SEL	Off, Current, Power, TCU	Off
LD CTL CUR UPPER	Off, 0.20...2.00 x I_e	Off
LD CTL CUR LOWER	Off, 0.20...2.00 x I_e	Off
LD CTL PWR UPPER	Off, 1...25000 kW	Off
LD CTL PWR LOWER	Off, 1...25000 kW	Off
LD CTL TCU UPPER	Off, 1...99%TCU	Off
LD CTL TCU LOWER	Off, 1...99%TCU	Off

NOTE: Prompt of settings LD CTL UPPER and LD CTL LOWER are dependent on the LD CONTROL SEL setting. All possible prompts are shown in Table 34.

NOTE: In addition to setting the Load Control levels, you must assign LD CTL UPPER and LD CTL LOWER to auxiliary output relays (one each); see Table 43, and Figure 16 for connection diagrams.

The 825-P provides an ability to control external devices based on parameter Load Control Selection. You can select Current, Power, or Thermal Capacity Utilized to operate auxiliary outputs.

When the selected parameter exceeds the level set by Load Control Upper for one second, the assigned auxiliary relay operates. The auxiliary relay resets when the parameter drops below the upper level setting for one second.

When the selected parameter drops below the level set by Load Control Lower for 1 second, the assigned auxiliary relay operates. The auxiliary relay resets when the parameter is above the lower-level setting for 1 second.

You can use this feature to control the motor load within set limits.

I/O Configuration

Analog Output

Table 35 - I/O Settings

Setting Prompt	Setting Range	Factory Default
ANALOG OUT SEL	LOAD_I, AVG_I, MAX_I, %THERM, WDG_RTD, BRG_RTD, PWR_kW, PF	LOAD_I

The expansion I/O option provides a 4...20 mA DC analog current output with a variety of output parameters. Use the Analog Output Select setting to select a parameter from the list of available options. Table 36 shows description and scaling of the output for different parameter selections.

Table 36 - Scaling of Analog Output

ANALOG OUT SEL (AOPARM)	Description	Output Scaling (4 mA)...(20 mA) (Unit)
LOAD_I	Average Load Current	0.0...1.0 Per Unit of FLA
AVG_I	Average Load Current	0.2...2.0 Per Unit of FLA
MAX_I	Maximum of the Phase currents	0.2...2.0 Per Unit of FLA
%THERM	Percentage Thermal Capacity	0...100%TCU
WDG_RTD	Hottest Winding RTD Temperature	0...250°C
BRG_RTD	Hottest Bearing RTD Temperature	0...250°C
PWR_kW	Motor Power	0.0...1.0 per unit FLVA
PF	Motor Power Factor	0.8 Lag...0.8 Lead

Select LOAD_I to scale the analog output based on motor current if the output is not of interest during overload conditions. Select either AVG_I or MAX_I to scale the analog output based on motor current and if the output is required during overload conditions.

Both LOAD_I and AVG_I use an average magnitude of three phase currents to drive the analog output; MAX_I uses a maximum magnitude of the three phase currents.

If the relay includes the voltage input option and you select PWR_kW parameter, the analog output is scaled using real power. The following defines per unit FLVA:

$$1 \text{ per unit FLVA} := 1.732 \cdot (\text{VNOM}) \cdot (\text{FLAn})$$

where:

VNOM	=	Nominal voltage setting
FLAn	=	Full Load Current setting (n = 1, for Speed-1 or 2 for Speed-2)

If the relay includes the voltage input option and you select PF parameter, the analog output is scaled using power factor. For power factors 0.8 lag, unity, and 0.8 lead, the analog outputs are 4 mA, 12 mA, and 20 mA, respectively.

Trip Inhibit (Block)

Table 37 - Trip Inhibit Settings

Setting Prompt	Setting Range	Factory Default
CURRENT IMBALANC	Y, N	N
JAM	Y, N	N
GROUND FAULT	Y, N	N
SHORT CIRCUIT	Y, N	N
UNDERCURRENT	Y, N	N
START INHIBIT	Y, N	N
PTC	Y, N	N
RTD	Y, N	N

NOTE: In addition to selecting the functions to be inhibited, you must assign Block Protection to an input. See Table 44 for a description and Figure 16 for a typical connection diagram.

With a Block Protection control input, one or more protective functions listed in Table 37 can be inhibited when the contact closes.

During certain operational phases, when the level (e.g., motor current) differs from the normal values, such as in the following situations.

- During starting: earth fault and short-circuit protection

- At no-load: protection against asymmetry and underload
- During brief overload phases: high overload/jam
- During commissioning and fault location: (localizing the source of the trouble) the selected functions are completely disabled as long as the control input is asserted.
- No warning
- No trip; no reset
- Tripping delays begin to run only after the function is re-enabled.

Output Relay Behavior

Table 38 - Relay Behavior Settings

Setting Prompt	Setting Range	Factory Default
TRIP FAIL-SAFE	Y, N	Y
AUX1 FAIL-SAFE	Y, N	Y
AUX2 FAIL-SAFE	Y, N	Y
AUX3 FAIL-SAFE	Y, N	Y
AUX4 FAIL-SAFE	Y, N	Y
AUX5 FAIL-SAFE	Y, N	Y
AUX6 FAIL-SAFE	Y, N	Y

The 825-P allows you to enable fail-safe output contact operation for relay contacts on an individual basis. When contact fail-safe is enabled, the relay output is held in its energized position when relay control power is applied and falls to its de-energized position when control power is removed. Contact positions with de-energized output relays are indicated on the relay chassis (and also in Figure 4).

When Trip Output Fail-safe is enabled and the Trip contact is appropriately connected to the motor breaker or contactor, the motor is automatically tripped when relay control power fails. This setting/connection philosophy is appropriate if the protected motor is more valuable than the process that the motor supports. In critical applications where the protected motor is not more valuable than the process, you may want the motor to run even if the relay is out of service. In this case, disable Trip Output Fail-safe by selecting N.

In addition, you can select an auxiliary outputs to be Fail-Safe or Non-Fail-safe, depending on your application.



ATTENTION: Pay close attention to the Trip Fail-Safe setting to ensure proper labeling of the plug connector for terminals 95, 96, and 98.

Timer Function

Table 39 - Timer Settings

Setting Prompt	Setting Range	Factory Default
ON DELAY T1	0...240 s	0
OFF DELAY T1	0...240 s	0
ON DELAY T2	0...240 s	0
OFF DELAY T2	0...240 s	0

NOTE: In addition to setting the On and Off Delays, you must assign TIMER1 and/or TIMER2 to a control input (see Table 44). You must also assign TIMER1T and/or TIMER2T to auxiliary output relays. See Table 43 for detail.

When you assign an input contact and an output auxiliary relay to appropriate parameters of Timer Function, the output responds to the change in input contact with the characteristics shown in Figure 33.

This feature has the following application examples:

- Time-graded switching on and off
- Delaying the transfer of alarm and trip messages

Figure 33 - Operating Characteristics of Timer Functions

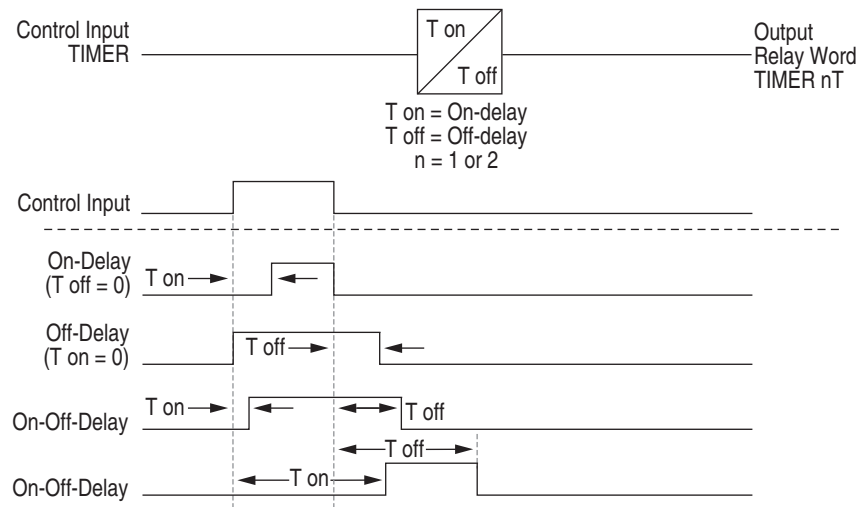

Front Panel Settings

Table 40 - Front Panel Settings

Setting Prompt	Setting Range	Factory Default
LCD TIMEOUT	Off, 1...30 min	15
LCD CONTRAST	1...8	5

The LCD TIMEOUT indicates the duration of inactivity before the LCD backlight will extinguish, the Access Level will be automatically reset and the present function will be automatically terminated. Use the front panel LCD Timeout setting as a security measure. If the display is within an Access Level 2 function, such as the relay setting entry, the function is automatically terminated (without saving changes) after inactivity for this length of time. The front-panel display returns to the default display (see Table 41 for the default rotating display settings).

If you prefer to disable the front-panel timeout function during relay testing, set the LCD Timeout equal to 0 minutes. Use the front panel LCD Contrast setting to adjust the contrast of the liquid crystal display.

Display Enable

Table 41 - Display Enable Settings

Setting Prompt	Setting Range	Factory Default
TIME & DATE	Y, N	N
GROUND CURRENT	Y, N	N
CURRENT IMBALANC	Y, N	N
FREQUENCY	Y, N	N
THERM CAP USED	Y, N	N
RTD TEMPERATURE	Y, N	N
VOLTAGE IMBALANC	Y, N	N
POWER	Y, N	N

The relay default front-panel rotating display shows unit identifiers (see Table 7) and magnitudes of measured phase currents and, if included, phase-to-phase voltages.

The Display Enable settings give you the option to add quantities listed in Table 41 to the default display. When you select Y for a quantity, it is added to the rotating display.

Voltage Imbalance and Power displays require the voltage input option. When the relay is equipped with external RTD inputs and the Display Enable RTD Temperature setting equals Y, the relay displays the temperatures of the hottest winding, bearing, and other RTDs, plus the ambient temperature.

I/O Assignments

Trip Relay I/O

Table 42 - Trip Relay Assignments

Setting Prompt	0	1	2	3	4	5	6	7	Description
TRIP A	X								Overload
		X							Undercurrent
			X						Jam
				X					Current Imbalance
					X				Short Circuit
						X			RTD (Winding/Bearing)
							X		PTC
								X	Ground Fault (Residual)
TRIP B	X								VAR
		X							Underpower
			X						Undervoltage
				X					Overvoltage
					X				Phase Reversal
						X			Power Factor
							X		Speed Switch
								X	Ground Fault (Core Balance)
TRIP C	X								Start Time
		X							Frequency 1
			X						Frequency 2
				X					RTD (Other)
					X				RTD (Ambient)
						X			PTC Error
							X		RTD Error
								X	MCM Error
TRIP D	X								Comm Idle
		X							Comm Loss
			X						Remote Trip
				X					Comm Fault
					X				Reserved
						X			Reserved
							X		Reserved
								X	Reserved

NOTE: The 825-P uses settings TRIPA through TRIPD and setting TRIP FAIL-SAFE (see Table 38) to determine the operation of the Trip Output.

The 825-P allows mapping of protection trip elements to the trip output. Table 42 shows the method of mapping elements using Relay Word bits associated with elements. Select 1 for each element you want to map using the TRIPA through TRIPD settings. The relay will OR them together to drive the Trip output. A logical “OR” describes when any one assigned element asserts, the Trip relay will operate.

Auxiliary I/O

Table 43 - Aux Assignments

Setting Prompt	0	1	2	3	4	5	6	7	Description
Aux# A	X								Overload
		X							Undercurrent
			X						Jam
				X					Current Imbalance
					X				Short Circuit
						X			RTD (Winding/Bearing)
							X		PTC
								X	Ground Fault (Residual)
Aux# B	X								VAR
		X							Underpower
			X						Undervoltage
				X					Overvoltage
					X				Phase Reversal
						X			Power Factor
							X		Speed Switch
								X	Ground Fault (Core Balance)
Aux# C	X								Start Time
		X							Frequency 1
			X						Frequency 2
				X					RTD (Other)
					X				RTD (Ambient)
						X			PTC Error
							X		RTD Error
								X	MCM Error

Table 43 - Aux Assignments

Setting Prompt	0	1	2	3	4	5	6	7	Description
Aux# D	X								Comm Idle
		X							Comm Loss
			X						Remote Trip
				X					Comm Fault
					X				Latch Trip
						X			Reserved
							X		Reserved
								X	Reserved
Aux# E	X								Overload Warning
		X							Undercurrent Warning
			X						Jam Warning
				X					Current Imbalance Warning
					X				RTD (Winding/Bearing) Warning
						X			Power Factor Warning
							X		Ground Fault (Core Balance) Warning
								X	Ground Fault (Residual) Warning
Aux# F	X								VAR Warning
		X							Underpower Warning
			X						Undervoltage Warning
				X					Overvoltage Warning
					X				Speed Switch Warning
						X			Frequency 1 Warning
							X		Frequency 2 Warning
								X	RTD (Other) Warning
Aux# G	X								RTD (Ambient) Warning
		X							Setting Warning
			X						General Warning
				X					Load Control — Upper
					X				Load Control — Lower
						X			Timer 1
							X		Timer 2
								X	Short Circuit Warning

Table 43 - Aux Assignments

Setting Prompt	0	1	2	3	4	5	6	7	Description
Aux# H	X								Stopped State
		X							Running State
			X						Starting State
				X					Star (Wye) Starting State
					X				Delta Starting State
						X			Start Command
							X		Network Control
								X	Reserved

NOTE: The 825-P uses settings AUX# A through AUX# H and setting AUX# FAIL-SAFE in the output logic (see Table 38 for more details) to determine the operation of the corresponding auxiliary.

NOTE: The AUX# A through AUX# D bytes are used to map trip functions to the output. The AUX# E through AUX# H bytes are used to map warning and status functions to the output.

The 825-P allows mapping of protection (trip and warning) and general-purpose control elements to the auxiliary outputs. Table 43 shows the method of mapping the elements using Relay Word bits associated with the elements, except the NETWORK, which is described below. Select 1 for each element you want to map using the AUX# A through AUX# H settings. The relay will OR them together to drive the Aux1 output.

By default, the trip protection assignments are unlatched. The 825-P with firmware revision 4.01 and higher can latch the trip protection assignment by setting bit 4 in Aux #D. The user must reset the 825-P with the front Test/Reset button or through communications to reset the auxiliary output.

If NETWORK is mapped to an AUX output, the DeviceNet network can control the output. The DeviceNet can individually control those Auxiliary outputs with NETWORK mapped to them.

Input I/O

Table 44 - Input Assignments

Setting Prompt	0	1	2	3	4	5	6	7	0	1	Description
IN#	X										Emergency Start
		X									Disable Settings
			X								Trip Reset
				X							Timer 1
					X						Timer 2
						X					Speed Switch
							X				Block Protection
								X			Speed 2
									X		Breaker/Contactor Auxiliary
										X	Remote Trip

NOTE: The 825-P allows one control function to an input and one input to a control function (see Table 5).

NOTE: In addition to setting an Input Assignment, you must connect a control contact to the input (see Figure 16 for a typical connection diagram).

The 825-P provides the ability to assign a control function to each control input. Table 44 shows the available control functions and the method of assigning them.

When a control input is asserted, the 825-P performs the control action assigned to the input. The control action of each of the available functions is described below:

Table 45 - Control Actions

Function	Control Action
Emergency Start	Overrides all active start inhibits, clears the % TCU to zero and immediately initiates a motor start.
Disable Settings	Disables all settings changes from the front panel, serial port, and DeviceNet network; when this input is asserted, you can view the settings but you cannot change them. Disables the Test/Reset push button function.
Trip Reset	Resets the Trip output and front-panel Trip LED, provided there is no trip condition present (including start inhibit lockouts).
TIMER1 (Timer 1 Input)	Provides input to Timer1 Function (see Figure 33 for more details).
TIMER2 (Timer 2 Input)	Provides input to Timer2 Function (see Figure 33 for more details).
Speed Switch	Provides input to Speed Switch Protection Function. See Speed Switch (Stalling During Start) on page 82 for more details.
Block Protection	Inhibits selected protection functions when the input is asserted. See Table 37 for more details.

Table 45 - Control Actions

Speed 2	When the SPEED2 control input is asserted and Two Speed Enable setting is Y the 825-P selects second values for the settings. See Table 11 for a full description of various settings. Use the SPEED2 input for two-speed motor applications. You can also use this input to change the settings in applications where ambient temperature varies appreciably (e.g., exposed water pumps with different capacities during daytime and at night).
Breaker/Contactor Auxiliary	Use input if motors have an operational idling current of less than 20% FLA. Use the auxiliary contact of motor contactor or another contact, which indicates that the motor is switched on. The relay uses this input information to correctly determine the Motor State (Running versus Stopped), particularly important during periods of low idling current.
Remote Trip	Use this input to trip the motor by remote protection or a control device (e.g., vibration switch and pressure switch).

Logic Explanation

Stop/Trip Logic

The 825-P tripping logic is designed to trip or stop motors energized through circuit breakers or contactors. Trip relay contacts 95/96 are designed for the purpose of being applied in motor control circuits. The relay logic lets you define the conditions that cause a trip and the performance of the trip relay output contacts.

Initiate Trip

The 825-P Trip Logic offers two ways to stop the protected motor:

- Trip Output Assignments.
- Serial Port or Network **STOP** Command.

Either of these two conditions triggers an event report. The relay controls the Trip output contacts, depending on the relay behavior setting Trip Fail-Safe.

Assign the protection element Relay Word bits that you want to cause the relay to trip to the Trip output (see Table 42).

Unlatch Trip

Following a fault, the trip condition is maintained until all of the following conditions are true:

- 0.5 second minimum trip duration time passes.
- a trip reset command is received as follows:
 - an Auto Reset bit from Overload, RTD, or PTC protection elements asserts.
 - a rising edge of the Target Reset control bit (from control input, front panel, serial port, network, or Emergency Start) is detected.
- all the motor lockout functions, described below, de-assert.

The relay automatically locks out the trip relay by asserting the trip signal under any of the following start-inhibiting conditions:

- **Restart (Anti-backspin) Block**
The restart block timer has not expired since the motor trip occurred. The trip condition is maintained until the timer expires.
- **Minimum Time Between Starts Lockout**
A new start is not permitted until after the minimum time between starts has passed. The trip condition is maintained until a start is permitted.
- **Starts-Per-Hour Limit Lockout**
If the starts-per-hour limit has been met, a new start is not permitted until 60 minutes after the oldest start. The trip condition is maintained until a start is permitted.
- **TCU Start Inhibit**
The motor thermal element % Thermal Capacity value is too high to permit a normal motor start without tripping. The trip condition is maintained until the % Thermal Capacity decreases to a level where a start can safely take place.

If any of the above protection functions is not enabled by the relay settings, that function does not affect trip unlatch.

Also note that the relay automatically asserts the trip signal if the motor stops and a lockout condition is true. The trip signal is maintained until all the enabled motor lockout conditions are satisfied.

Trips initiated by the serial port command or by network operation are maintained for at least 0.5 second.

Start & Emergency Restart Logic

If the Trip output contact is not asserted, the relay asserts the START Relay Word bit in response to any of the following conditions:

- the Emergency Restart Relay Word bit asserts.
- you execute the **STR** serial port command or a DeviceNet **Start Motor** control command.

The START Relay Word bit remains asserted for 0.5 seconds, unless the relay trips. If the relay trips before the 0.5 second timer expires, the relay resets the timer, clearing the START Relay Word bit.

In an emergency, it could be necessary to quickly start the motor even though a protection lockout condition exists and is holding the Trip output contact asserted. The lockout might be a result of the thermal element or another protection function. You can override all of the lockout conditions using the Emergency Restart function.

The relay asserts the Emergency Restart bit in response to any of the following conditions:

- the control input assigned to Emergency Restart asserts.
- the relay receives a network Emergency Restart control command.

When the Emergency Restart bit asserts, the relay does the following:

- Resets the motor thermal element capacity used to 0%.
- Manipulates the Starts-Per-Hour, Minimum Time Between Starts, and Anti-backspin functions to permit an immediate start.
- De-asserts the Trip output contact if a fault detecting element is not picked up.
- Initiates a motor start.

Overload Curves

Figure 34 - Thermal Overload Curves

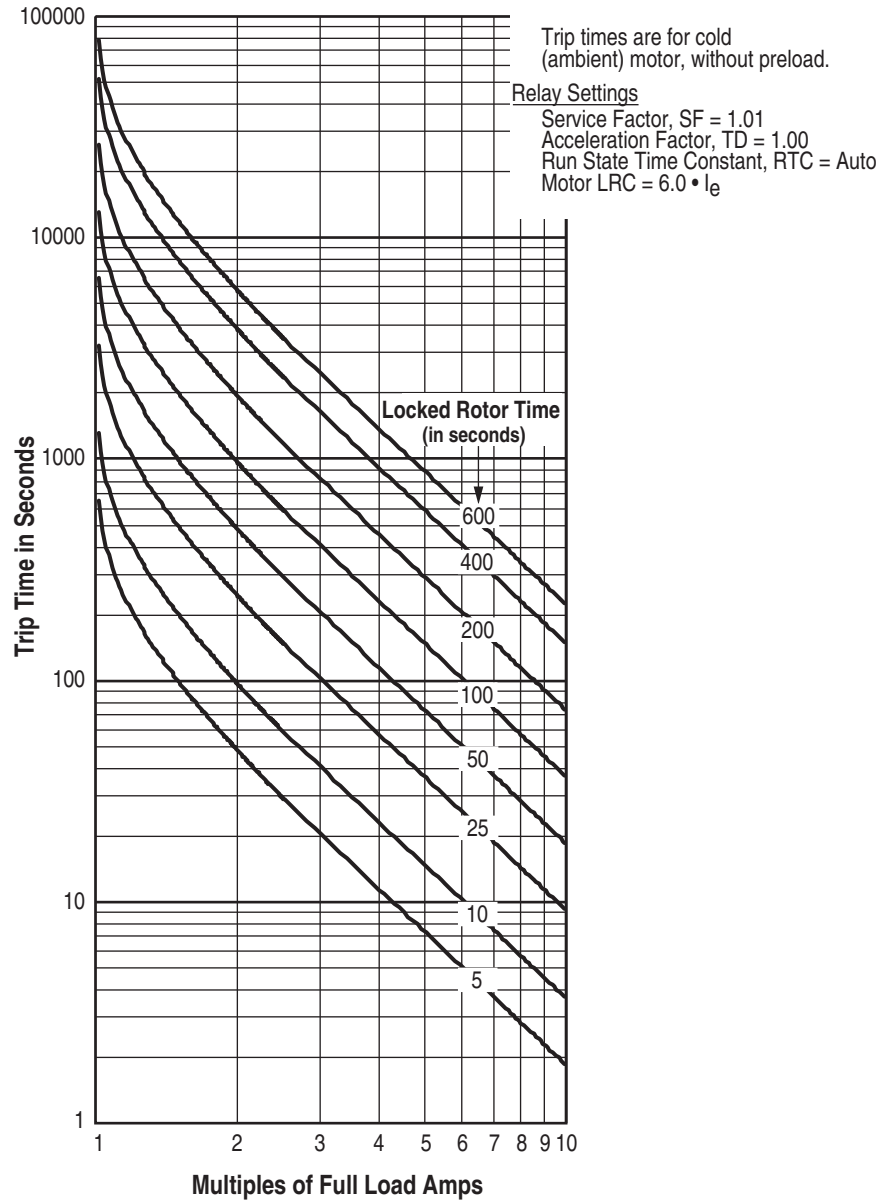

Metering & Monitoring

Overview

The 825-P relay includes metering functions to display the present values of current, voltage (if included), and RTD measurements (from the external 825-PR12D Module). The relay provides the following methods to read the present meter values:

- Rotating front panel display
- Front panel menu
- Front panel EIA-232 serial port
- Network port (if installed)
- Analog output

For monitoring and preventive maintenance purposes, the 825-P provides a motor operating statistics report, available using either the front panel, the serial port, or the optional network port.

Metering

The 825-P meter data falls into the following categories:

- Instantaneous metering
- Thermal metering
 - Thermal model metering
 - RTD metering

Note that the phases and neutral are identified by 1, 2, 3, N for currents and A, B, C, N for voltages.

Table 46 details each of the meter data types in the 825-P. Chapter 3: Front Panel Operation and Chapter 5: Using MPS Explorer describe how to access the various types of meter data using the relay front-panel and communications ports.

Instantaneous Metering

Table 46 - Measured Values

Relay Option	Meter Values
All Models	Line Currents L1, L2, and L3 IN (Core-Balance Ground Fault Current) magnitudes (A) and phase angles (°)
	IG (Residual Ground Fault Current) magnitude (A) and phase angle (°) IM (Average Current Magnitude) Average Motor Load ($x I_e$) Current Imbalance % System Frequency (Hz)
With Voltage Option	VAB, VBC, VCA or VAN, VBN, VCN, VG magnitudes (V) and phase angles (°) Average Voltage (L-L or L-N) Voltage Imbalance % Real Power (kW) Reactive Power (kVAR) Apparent Power (kVA) Power Factor Real Energy (MWh) Reactive Energy (MvARh) Apparent Energy (MvAh)

All angles are displayed between -180° ... $+180^\circ$. Delta-connected PT angles are referenced to VAB or L1 and wye-connected PT angles are referenced to VAN or L1. If the voltage channels are not supported or if VAB < 13V (for Delta) or VAN < 13V (for Wye), PT angles are referenced to L1 current.

Thermal Metering

The thermal metering function reports the present values of the RTD input temperatures and several quantities related to the motor overload protection function (Table 47).

Table 47 - Thermal Meter Values

Relay Option	Thermal Values
All Models	Average Motor Load ($x I_e$) Thermal Capacity Used % Time to Trip (s) Time to Reset (min) Starts Available
With External 825-PR12D Module	All RTD Temperatures RTD % Thermal Capacity

NOTE: If the Overload Protection is disabled, the relay always reports % Thermal Capacity = 999 and Calculated Time to Thermal Trip (s) = 9999.

The thermal meter function also reports the state of connected RTDs if any have failed. Table 48 shows failure messages.

Table 48 - RTD Input Status Messages

Message	Status
Open	RTD leads open
Short	RTD leads shorted
Comm Fail	Fiber-optic communications to 825-PR12D Module have failed
Stat Fail	825-PR12D Module self-test status failure

Power Measurement Conventions

The 825-P uses the IEEE convention for power measurement assuming motor action. The implications of this convention are shown in Figure 35.

Figure 35 - Complex Power Measurement Conventions

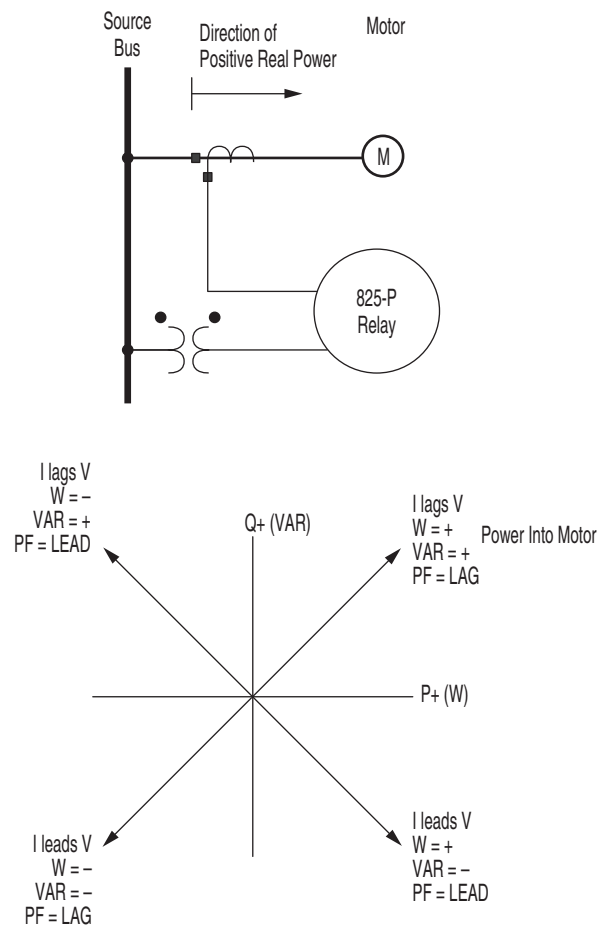

In the 825-P, reported positive real power is always into the motor.

Motor Operating Statistics

The 825-P retains useful machine operating statistics information regarding the protected motor.

NOTE: While the relay power is off, the elapsed timers do not advance. If relay power is off for a significant amount of time, the elapsed calendar time does not match the elapsed time recorded by the relay.

The motor operating statistics include motor operating history, such as time running, time stopped, percent time running (of total time), number of starts, and number of emergency starts.

Analyzing Events

Overview

The 825-P relay provides several facilities to analyze the cause of relay trip operations. Use these tools to help diagnose the cause of the relay trip operation and more quickly restore the protected motor to service.

Each tool listed below provides increasing detail regarding the causes of a relay operation.

- Event Summary Reports
- Serialized Events Recording

Event Summary Reports

Each time the 825-P trips and in response to other selected conditions, it captures motor current and voltage (if included). This collection of data is called an event summary report. This section explains what causes the relay to save an event summary report, and what the event summary data means.

The relay stores the five most recent event summary reports in nonvolatile memory. These reports are numbered 1 through 5. When the relay stores a new report, it discards the oldest report if five reports are already in memory. Use the event summary data to help discern the cause of relay trip operations.

View the present collection of event summary reports using the front panel Events menu selection or the serial port. Each event summary report includes the following information:

- Type of event, from the list of event type strings in Figure 24
- Event number, date, and time
- Magnitudes of the line, core balance, and residual currents
- Magnitudes of the line-to-neutral (wye) or phase-to-phase voltages (delta), if included

Report Triggering

The 825-P triggers an event summary report when the relay trips by protection elements.

Current and Voltage Columns

Table 49 summarizes the event summary report current and voltage columns.

Table 49 - Event Report Current and Voltage Columns

Column Heading	Definition
L1	Current measured by channel L1 (primary A)
L2	Current measured by channel L2 (primary A)
L3	Current measured by channel L3 (primary A)
RES	Residual current (L1 + L2 + L3, primary A)
CB	Current measured by channel IN (primary A)
VAN or VAB	Voltage measured by channel VAN or VAB (primary V)
VBN or VBC	Voltage measured by channel VBN or VBC (primary V)
VCN or VCA	Voltage measured by channel VCN or calculated from VAB and VBC (primary V)
VG	Zero-sequence voltage (VAN + VBN + VCN, primary V)

Serialized Events Recording (SER) Report

SER Triggering

The 825-P relay stores an entry in the SER report for a change of state of any one of the elements listed in Table 112 on page 235 and Table 113 on page 238. The relay saves up to 512 records in nonvolatile memory.

The relay adds the following message to the SER to indicate power up or settings change conditions:

- Relay newly powered up or settings changed
- Each entry in the SER includes SER row number, date, time, element name, and element state

Example Reports

Event Summary Report

The example event summary report in Figure 36 corresponds to the example Serialized Events Recording (SER) report in Figure 37.

Figure 36 - Example Event Summary Report

```
=>SUM <Enter>

825-P Modular                               Date: 06/07/2003   Time:
14:50:06:032

Prot. System

Event #: 1                                  Event: No Trip

Event Date: 06/07/2003                     Event Time: 14:39:47:907

                L1      L2      L3      RES      CB
CURRENT MAG (A):    259.7    191.6    190.6    0.1      68.2
                VAN      VBN      VCN      VG
VOLTAGE MAG L-N (V):  458      460      457      456
```

Serialized Events Recording (SER) Report

The example SER report in Figure 37 includes records of events that occurred before the beginning of the event summary report in Figure 36. The SER event report rows are explained in Table 50, numbered in correspondence to the Item # column.

Figure 37 - Example SER Report

```
=>SER <Enter>

825-P Modular                               Date: 07/07/2003   Time: 14:50:04.744
Prot. System
FID=825-Modular xxxx-Vxxxx-Zxxxxxx-Dxxxxxxxxx

#  DATE      TIME      ELEMENT  STATE
11 06/07/2003 14:34:32.786 STOPPED  Deasserted
10 06/07/2003 14:34:32.786 STARTING Asserted
9  06/07/2003 14:34:42.795 RUNNING  Asserted
8  06/07/2003 14:34:42.795 STARTING Deasserted
7  06/07/2003 14:39:45.398 AMBALRM  Asserted
6  06/07/2003 14:39:47.907 AMBTRIP  Asserted
5  06/07/2003 14:39:47.907 TRIP     Asserted
4  06/07/2003 14:39:48.007 AMBTRIP  Deasserted
3  06/07/2003 14:39:48.007 AMBALRM  Deasserted
2  06/07/2003 14:39:48.028 STOPPED  Asserted
1  06/07/2003 14:39:48.028 RUNNING  Deasserted
```

Table 50 - Example SER Report Explanations

Item #	Explanation
11, 10, 9, 8, 7	After a 10-second accelerating time, the motor relay indicates the motor is running (9). Later, the ambient temperature alarm element asserts.
6, 5	The ambient temperature trip element times out, causing the relay to trip. Trip is asserted.
4, 3	Declining temperature allows the elements to drop out.
2, 1	As the current continues to drop, the relay declares the motor stopped.

825-PDN DeviceNet Communication Card

Introduction

The 825-PDN DeviceNet Communication Card is an optional accessory that enables connection of the 825-P Modular Protection System to the DeviceNet automation network. The card occupies the communication expansion slot (Slot C) in the 825-P Modular Protection System.

Figure 38 - 825-P Modular Protection System Back Panel View

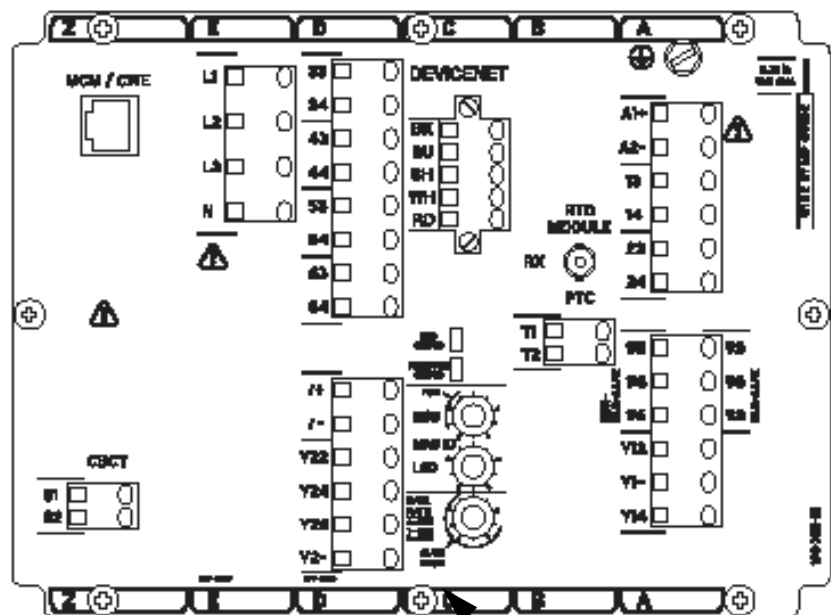

Communication Expansion Slot

Figure 39 - 825-PDN Component Overview

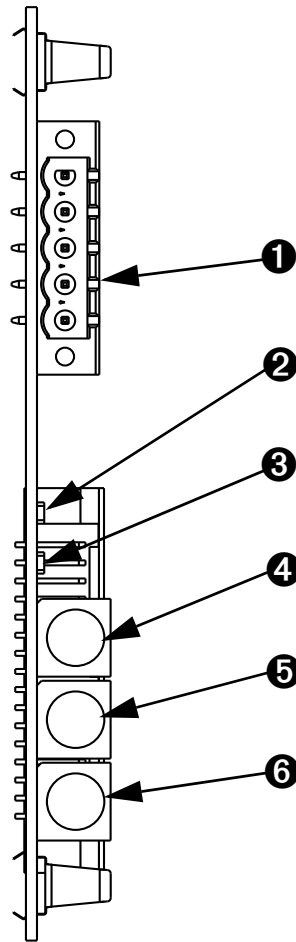

Table 51 - Part Descriptions

#	Part	Description
1	DeviceNet Connector	Accepts a 5-pin linear DeviceNet plug.
2	Bus Status LED	Status indicator for backplane communications.
3	Network Status LED	Status indicator for DeviceNet communications.
4	Node Address Switch	Rotary switch for setting the most significant digit (MSD) of node address.
5	Node Address Switch	Rotary switch for setting the least significant digit (LSD) of node address.
6	Data Rate Switch	Rotary switch for selecting the DeviceNet data rate at which the card communicates.

Features

The 825-P DeviceNet Communication Card features the following:

- The card receives the required power from the DeviceNet network.
- Rotary switches let you set the node address and network data rate prior to mounting in the 825-P Modular Protection System and applying power. Alternatively, the switches can be set to positions that allow for configuration of these settings over the DeviceNet network, utilizing a network configuration tool such as RSNNetWorx for DeviceNet.
- Status indicators report the status of the device bus and network communications. They are visible from the back panel of the 825-P Modular Protection System as installed.
- UCMM (Unconnected Message Manager) messages are supported with the ability to allocate up to 3 explicit message connections concurrently.
- DeviceNet Group 2 slave functionality including:
 - Explicit connection
 - Polled connection
 - 1 COS (Change of State)/Cyclic connection
- Full DeviceNet Parameter Object support allows EDS files to be extracted from all units.
- Settings are provided for user-defined behavior of the 825-P Modular Protection System auxiliary relays for Comm Fault and Comm Idle conditions.
- Group 4 faulted node recovery is supported. You can configure a device even when it is faulted on the network if the configuration tool supports faulted node recovery.
- DeviceLogix component technology provides the capability to perform logic operations at the device level. A total of 80 function blocks are supported.

Required Equipment

Equipment Shipping with the Card

When you unpack the card, verify that the package includes:

- One DeviceNet communication card
- One five-pin linear DeviceNet plug
- Two labels that the installer affixes to the 825-P Modular Protection System, one to the top and one to the back panel
- 825-P Option Card installation instructions

User-Supplied Equipment

- Small slotted screwdriver (0.6 x 3.5 mm)
- DeviceNet cable, a thin cable with outside diameter of 6.9 mm (0.27 in.), is recommended
- Configuration tool (e.g., RSNetWorx for DeviceNet)
- Computer with an installed DeviceNet communication adapter
- 825-P User Manual

Wiring

1. Remove power from the DeviceNet network and 825-P Modular Protection System relay
2. Use static control precautions
3. Connect a DeviceNet cable to the network
4. Terminate the bare leads of the DeviceNet cable to the 5-pin linear plug as illustrated in Figure 40

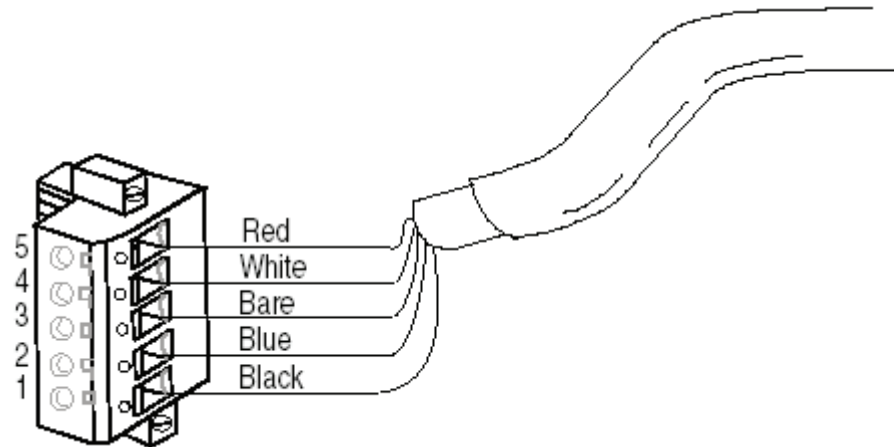
Figure 40 - Connecting 5-Pin Linear Plug to DeviceNet Cable**Table 52 - Linear Plug Function Descriptions**

Terminal	Color	Signal	Function
5	Red	V+	Power Supply
4	White	Can_H	Signal High
3	Bare	SHIELD	Shield
2	Blue	CAN_L	Signal Low
1	Black	V-	Common

5. Connect the wired 5-pin linear plug to the 825-PDN DeviceNet Communication Card, securing with the two screws

Node Commissioning

The 825-PDN DeviceNet Communication Card is shipped with a default software node address (MAC ID) setting of 63 and the data rate set to Autobaud. Each device on a DeviceNet network must have a unique node address which can be set to a value from 0 to 63.

Keep in mind that most DeviceNet systems use address 0 for the master device (Scanner) and node address 63 should be left vacant for introduction of new slave devices.

The node address and data rate for the 825-PDN DeviceNet Communication Card can be changed using software or by setting the hardware switches that reside on the card. While both methods yield the same result, it is a good practice to choose one method and deploy it throughout the system.

Setting the Hardware Switches

Use the following steps to commission the card:

1. Set the node address switches.

Figure 41 - Node Address and Data Rate Setting Switches

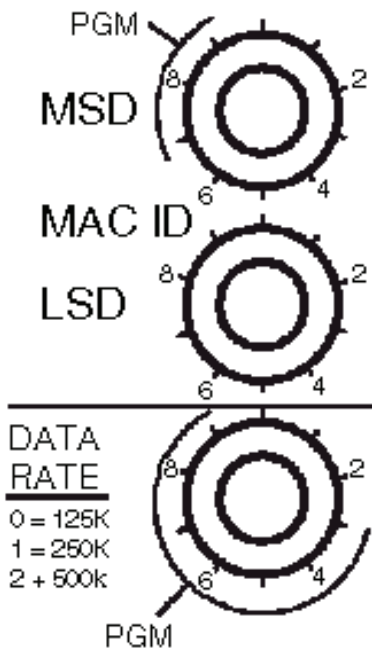

Table 53 - Node Address MAC ID Setting

Switch Setting	Description
0...63	Node address setting determined by switch values when set in this range. <ul style="list-style-type: none"> • MSD = most significant digit • LSD = least significant digit
64...99	For switch settings in this range, node address setting is determined by the software setting using the RSNetWorx for DeviceNet configuration tool.
99	Factory default setting.

2. Set the data rate switches.

Table 54 - Data Rate Setting

Switch Setting	Description
0	125 K
1	250 K
2	500 K
3...9	For a switch setting in this range, data rate setting is determined by the software setting using the RSNetWorx for DeviceNet configuration tool. Note: The card is factory default set to autobaud to the network data rate.
9	Factory default setting.

3. Cycle power to the card to initialize the new settings.

Using RSNetWorx for DeviceNet

Follow these steps if the hardware switches are left in the factory default settings or in the range of 64...99 for the node address and 3...9 for the data rate. To begin the configuration of the 825-P Modular Protection System using software, execute the RSNetWorx software and complete the following procedure. You must use RSNetWorx Revision 3.21 Service Pack 2 or later.

1. After going on-line using RSNetWorx for DeviceNet, do the following:
 - Select the **Network** menu.
 - Select **Online**.
2. Choose the appropriate DeviceNet PC interface. In this example, a 1784-PCIDS module is chosen. Other common DeviceNet interfaces are the 1770-KFD, and 1784-PCD.

NOTE: DeviceNet drivers must be configured using RSLinx prior to being available to RSNetWorx.

3. Select **OK**.
4. RSNetWorx notifies the user to upload or download devices before viewing configuration. Select **OK**.
5. RSNetWorx now browses the network and displays all of the nodes it has detected on the network. For some versions of RSNetWorx software, the 825-P Modular Protection System EDS files and icon might not be included, and the device could be identified as an unregistered device.

If the screen appears like in Figure 42, continue with Registering an EDS file.

Figure 42 - Network Online Screen

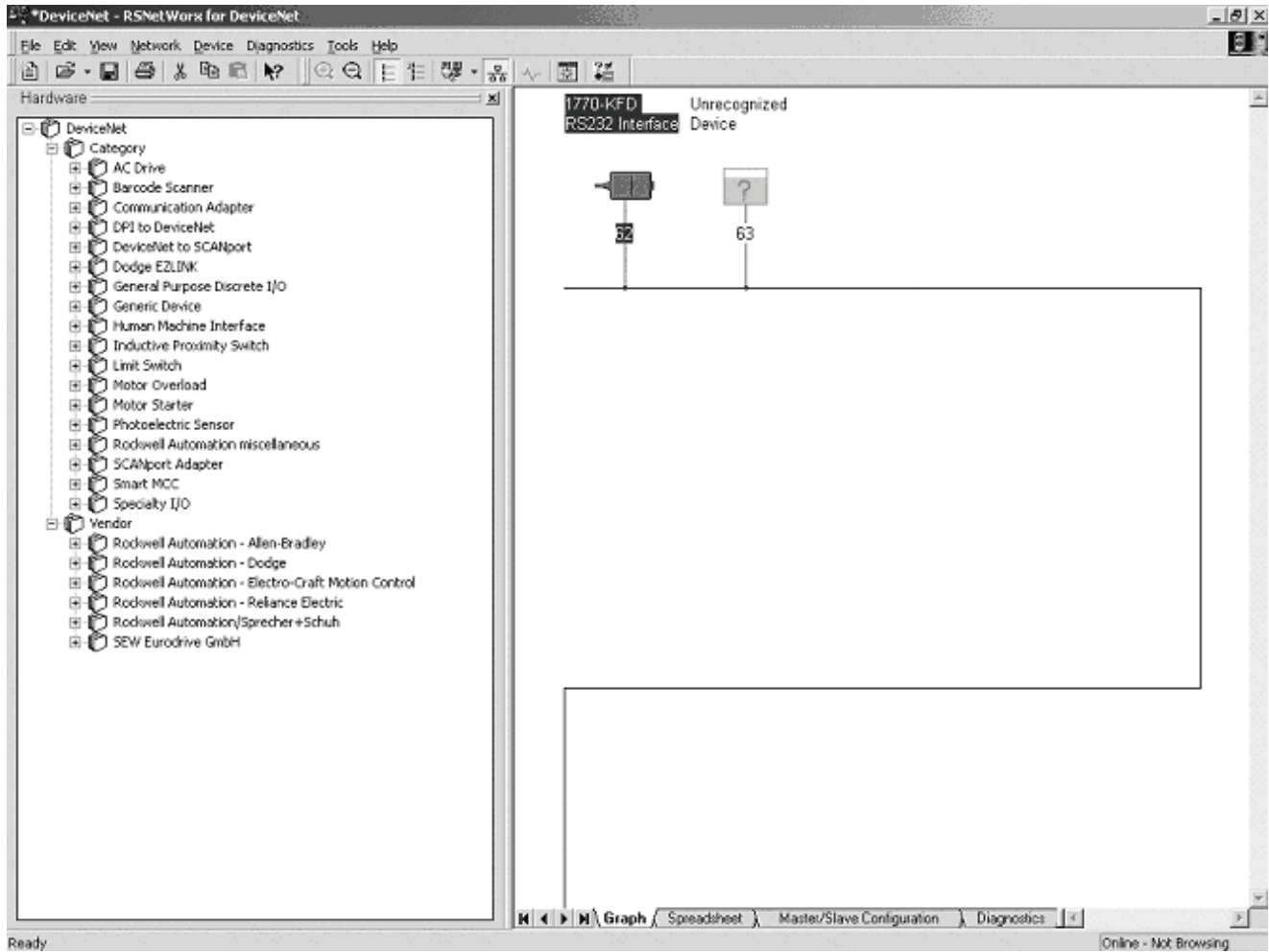

6. If RSNetWorx recognizes the device as an 825-P Modular Protection System, skip ahead to the section Using the Node Commissioning Tool of RSNetWorx for DeviceNet.

Registering an EDS File

Download the 825-P DeviceNet EDS from the Internet at <http://www.rockwellautomation.com/rockwellautomation/support/networks/eds.page?>

Use the RSLinx Classic EDS Hardware Installation tool to register the new EDS file.

Using the Node Commissioning Tool of RSNetWorx for DeviceNet

1. From the Tools menu at the top of the screen, select **Node Commissioning**.
2. To prompt a screen similar to Figure 43, select **Browse**.

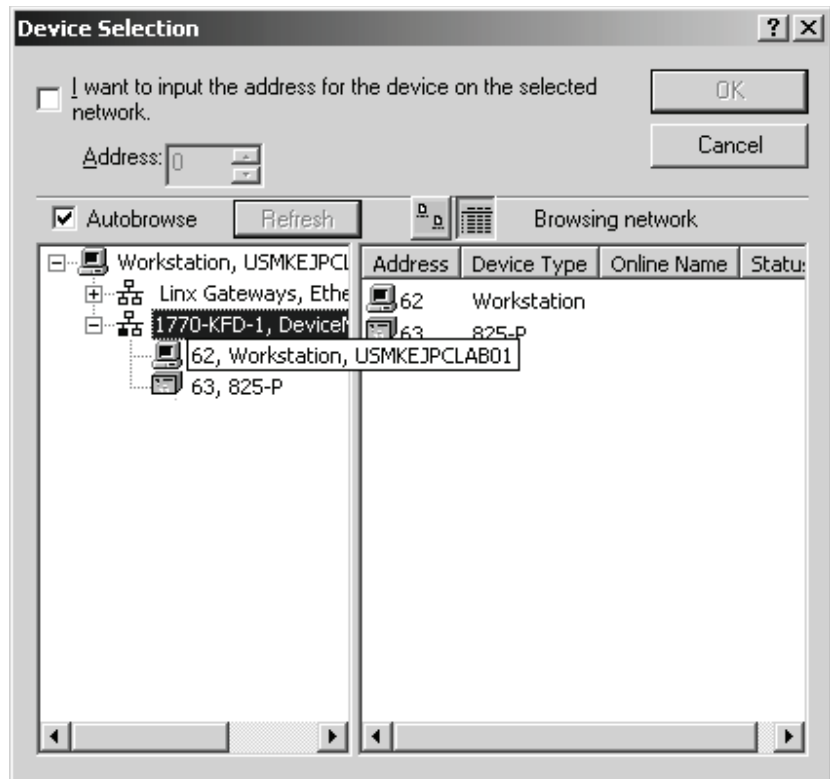
Figure 43 - Node Commissioning Device Solution Window**Explicit Messaging**

The 825-PDN is capable of using explicit messages to retrieve data that is not automatically acquired based on the input and output assembly of the device.

The example shows how to configure an explicit message with a ControlLogix processor.

To assist in the development of the example, the network consists only of the 825-P Modular Protection System and scanner. Therefore, the only mapped information in the scanner is the 825-P Modular Protection System.

The following example utilizes the input and output assemblies of 50 and 2.

The tables below list the data configuration for the ControlLogix platform and include the Tag Name as used in the example program.

Table 55 - Example ControlLogix Input Addressing (produced assembly)

Instance 50 ODVA Overload								
Byte	Bit 7	Bit 6	Bit 5	Bit 4	Bit 3	Bit 2	Bit 1	Bit 0
Address	Local:1:I. Data[1].7	Local:1:I. Data[1].6	Local:1:I. Data[1].5	Local:1:I. Data[1].4	Local:1:I. Data[1].3	Local:1:I. Data[1].2	Local:1:I. Data[1].1	Local:1:I. Data[1].0
Tag Name								Status_Fault
0	Reserved	Reserved	Reserved	Reserved	Reserved	Reserved	Reserved	Fault

Table 56 - Example ControlLogix Output Address (consumed assembly)

Instance 2 ODVA Overload								
Byte	Bit 7	Bit 6	Bit 5	Bit 4	Bit 3	Bit 2	Bit 1	Bit 0
Address	Local:1:O. Data[1].7	Local:1:O. Data[1].6	Local:1:O. Data[1].5	Local:1:O. Data[1].4	Local:1:O. Data[1].3	Local:1:O. Data[1].2	Local:1:O. Data[1].1	Local:1:O. Data[1].0
Tag Name						Control_fault Reset		
0	Reserved	Reserved	Reserved	Reserved	Reserved	Flt Reset	Reserved	Reserved

The explicit message Request and Response is configured within the MSG function. The MSG function can be found in the Input/Output tab of RSLogix 5000. Note that in the ControlLogix program example, rung 6 is the only required logic to complete the explicit message request.

Table 57 - MSG Function Illustration

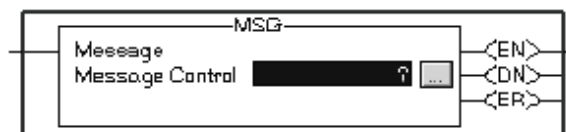

Setting Up the MSG instruction

A tag name must be given to the MSG function before the rest of the information can be defined. In this example a tag was created with the name explicit_mess. After the instruction has been named, click on the gray box to define the rest of the instruction.

See Figure 58 as an example that shows the exact data format to perform a Get Attribute Single request. This message specifically accesses parameter 104, Phase

CT Ratio. See Table 59, Common Configuration Examples for 825-P Modular Protection System for additional configurations.

Table 58 - Message Configuration

Table 59 - Description of Message Configuration Fields

Field	Description
Message Type	Select CIP Generic from pull-down menu to configure an explicit message.
Destination Element	Tag name of the location you are going to place the response information. In this example a tag was created with the name explicit_data.
Service Type	Pull-down menu has several options, however only the Get Attribute Single is used for this example. The Class, Instance, and Attribute define the actual information being requested. Additional configurations of these parameters can be found in Appendix B.
Class	In this example, the value is F.
Instance	In this example, the value is 104.
Attribute	In this example, the value is 1.
After the above information has been entered, click on the communication tab	
Path	Path defines the route the message takes to get to the device it is intended for. In this example the path is Scanner,2,4; where scanner is the name of the 1756-DNB in the rack, 2 represents the DeviceNet port, and 4 represents the physical node address of the 825-P Modular Protection System.

Figure 44 - Scanner Path

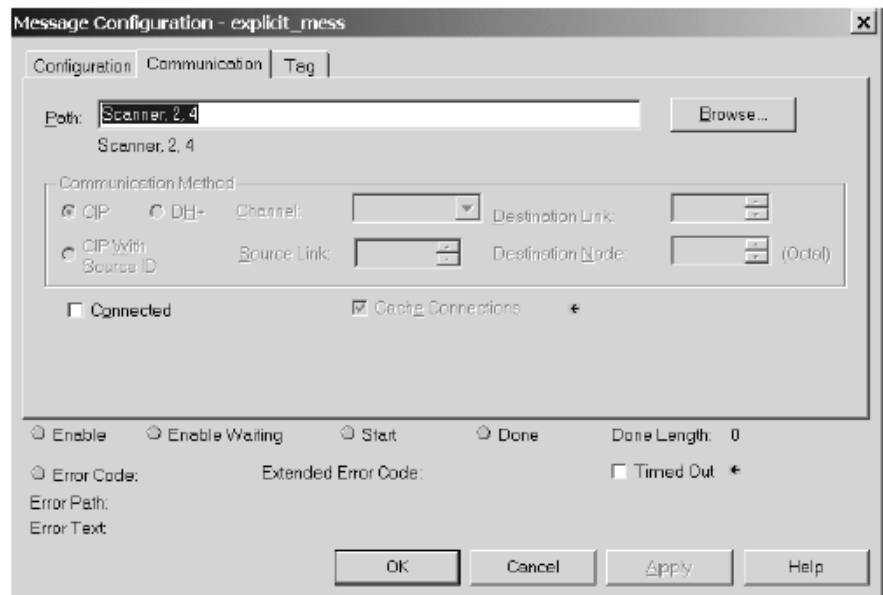

DeviceLogix

DeviceLogix is a stand-alone Boolean program, which resides within the 825-PDN DeviceNet Communication Card. The program is embedded in the product software so there is no additional module required to use this technology, however RSNetWorx for DeviceNet is required to program the device.

In addition to the actual programming, DeviceLogix can be configured to operate under specific situations. It is important to note that the DeviceLogix program only runs if the logic has been enabled. This can be done within the Logic Editor of RSNetWorx. The operation configuration is accomplished by setting the Network Override and Communication Override parameter.

The following information describes the varying levels of operation:

- If both overrides are disabled and the logic is enabled, the only time DeviceLogix runs is if there is an active I/O connection with a master, i.e., the master is in Run mode. At all other times, DeviceLogix is running the logic, but does not control the status of the outputs.
- If the Network Override is enabled and the logic is enabled, then DeviceLogix controls the state of the outputs when the PLC is in Run mode and if a network fault such as Duplicate MAC ID or Module Bus off condition occurs.

- If the Communications Override is enabled and the logic is enabled the device does not need any I/O connection to run the logic. As long as there is control power and a DeviceNet power source connected to the device, the logic controls the status of the outputs.

DeviceLogix has many applications and the implementation is typically only limited to the imagination of the programmer. Keep in mind that the application of DeviceLogix is only designed to handle simple logic routines.

DeviceLogix is programmed using simple Boolean math operators, such as AND, OR, NOT, timers, counters, and latches. Decision making is made by combining these Boolean operations with any of the available I/O. The inputs and outputs used to interface with the logic can come from the network or from the device hardware. Hardware I/O is the physical Inputs and Outputs located on the device such as push buttons and pilot lights that are connected to the 825-P Modular Protection System.

There are many reasons to use the DeviceLogix functionality, but some of the most common are listed below:

- Increased system reliability
- Improved diagnostics and reduced troubleshooting
- Operation independent of PLC or Network status
- Continue to run process in the event of network interruptions
- Critical operations can be safely shutdown through local logic

DeviceLogix Programming Example

The following example shows how to program a simple logic routine to interface the 825-P Modular Protection System with a remote hard-wired tower light and a reset button. In this case, the I/O is wired as shown in the table.

IMPORTANT	Before programming logic, it is important to decide on the conditions under which the logic run. As defined earlier, the conditions can be defined by setting parameter 8 (Network Override) and parameter 9 (Comm Override) to the value that you want.
------------------	--

Table 60 - Hardware Bit Assignments and Description for the 825-P Modular Protection System

Input Table		Output Table	
Bit	Description	Bit	Description
Input 2	Reset Button	Flt Reset	Reset Overload
		Output 5	Tower Light

1. While in RSNetWorx for DeviceNet, double-click **825-P Modular Protection System**.
2. Select tab **DeviceLogix**.
3. If you are on-line with a device, in the dialog box that appears asking you to upload or download, select **Upload**.
4. Select **Start Logic Editor**.
5. Do one of the following:
 - If programming off-line, continue to next step.
 - Do the following:
 - a. If not programming off-line, select **Edit**.
 - b. When asked if you want to enter edit mode, select **Yes**. In edit mode, the entire list of function blocks is displayed in the toolbar.
6. Left-click the **AND** function block.
7. Move your cursor into the grid.
8. Left-click to drop the function onto the grid.
9. From the toolbar, select **Discrete Input Point**.
10. From the pull-down menu, select **Input 2**. This is the remote Reset button that is based on the I/O table example.
11. Drag the input to the left of the **AND** function.
12. To drop the input on the page, left-click on the position that you want.
13. Position your cursor over the tip of **Input 2**. The pin tip turns green.
14. Click on the pin tip when it turns green.
15. Move your cursor toward the input of the **AND** function. A line follows the cursor. When a connection can be made, the tip of the **AND** function also turns green.
16. Click on **Input**. The line is drawn from **Input 2** to the **Input 1** of the **AND** function.

NOTE: If this was not a valid connection, one of the pin tips would have turned **red** rather than green. Double-clicking on the unused portion of the grid or pressing **Esc** at any time cancels the connection process.

17. From the toolbar, select **Module Status Point**.

18. From the pull-down menu, select **Fault**.
19. Place the input to the left of the **AND** function.
20. Connect the input to the **Input 2** of the **AND** latch.
21. From the toolbar, select **Network Output Point**.
22. From the pull-down menu, select **Flt Reset**.
23. Select **OK**.
24. Moving your cursor into the grid, place the **Output** to the right of the **AND** function block.
25. Connect the **Output** of the **AND** function block to **Flt Reset**.

Figure 45 - DeviceLogix Logic Editor Screen

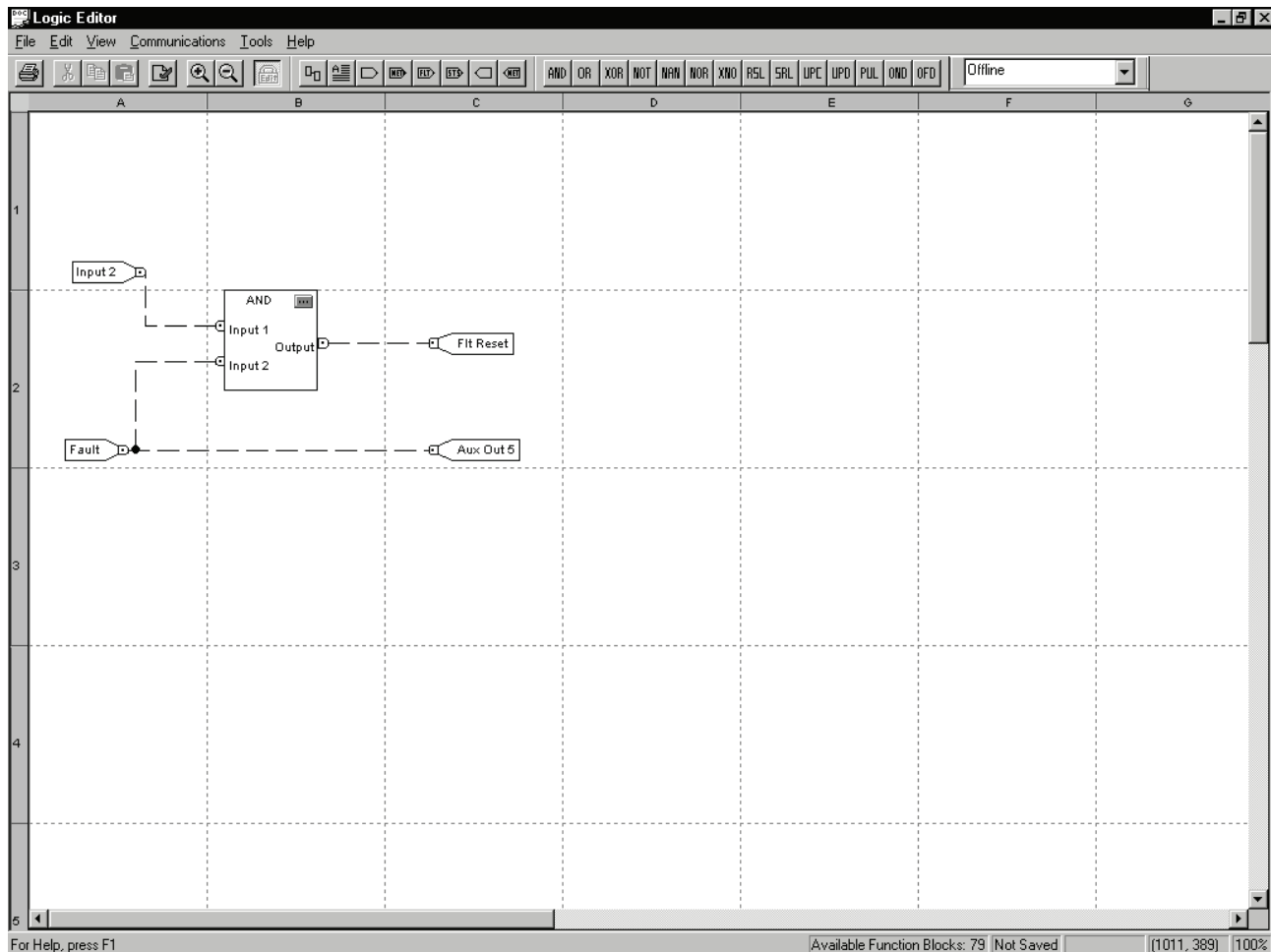

26. From the toolbar, select **Discrete Output Point**.
27. From the pull-down menu, select **Aux Out 5**. This is the tower light output listed in the I/O table example.

28. Select **OK**.
29. Moving cursor into the grid, place **Aux Out 5** to the right of the **AND** function block
30. Correct the **Fault Input** to the **Aux Out 5**.
31. Do one of the following:
 - In the toolbar, select **Tools**.
 - From the pull-down menu, select **Logic Verify**.
32. To toggle out of edit mode if you are online with a device, select **Tools**.
33. After selecting **Edit** from the main menu, select **Download** from the pull-down menu (right corner of the toolbar).

NOTE: The PLC key switch must be in the Program position. If not, the download does not occur and a generated error occurs.

34. When the download is successful, select **OK**.
35. From the same pull-down menu, select **Logic Enable On**.
36. The 825-P Modular Protection System is now programmed and the logic is active.

Parameter Groups

The 825-PDN Device Communication Card contains five parameter groups. The parameters shown in the DeviceLogix Parameters, DeviceNet Parameters, Aux. Output Parameters, Misc. Parameter, and Status Parameters are discussed in this section.

A complete list of all DeviceNet parameters is described in Appendix B.

Status Parameters	DeviceNet Parameters	Aux. Output Parameters	Misc. Parameters	DeviceLogix Parameters
Hdw Inputs	Autobaud Enable	GrpA Pr FltState	Set To Defaults	Net Inputs 1
Hdw Outputs	Consumed IO Assy	GrpA Pr FltValue		Net Inputs 2
Trip Status 1	Produced IO Assy	GrpA DN FltState		Net Outputs
Trip Status 2	Prod Assy Word 0	GrpA DN FltValue		Network Override
Warn Status 1	Prod Assy Word 1	GrpA DN IdlState		Comm Override
Warn Status 2	Prod Assy Word 1	GrpA DN IdlValue		Net Out COS Mask
DNet Status	Prod Assy Word 3	GrpB Pr FltState		
	Prod Assy Word 4	GrpB Pr FltValue		
	Prod Assy Word 5	GrpB DN FltState		
	Prod Assy Word 6	GrpB DN FltValue		
	Prod Assy Word 7	GrpB DN IdlState		
	Consumed IO Size	GrpB DN IdlValue		
	Produced IO Size	GrpC Pr FltState		
	Status COS Mask 1	GrpC Pr FltValue		
	Status COS Mask 2	GrpC DN FltState		
	Trip COS Mask 1	GrpC DN FltValue		
	Trip COS Mask 2	GrpC DN IdlState		
	Warning COS Mask 1	GrpC DN IdlValue		
	Warning COS Mask 2			
	DNet Voltage			

Modbus RTU Communications

Overview

This chapter describes the communications features supported by the 825-P Modbus® RTU option card.

Complete specifications for the Modbus protocol are available from the Modicon web site at www.modicon.com.

Enable Modbus protocol using the serial port settings. When Modbus protocol is enabled, the relay switches the port to Modbus protocol and deactivates the ASCII protocol.

Modbus RTU is a binary protocol that permits communication between a single master device and multiple slave devices. The communication is half duplex; only one device transmits at a time. The master transmits a binary command that includes the address of the desired slave device. All of the slave devices receive the message, but only the slave device with the matching address responds.

The 825-P Modbus communication allows a Modbus master device to do the following:

- Acquire metering, monitoring, and event data from the relay.
- Control 825-P output contacts and remote bits.
- Read the 825-P self-test status and learn the present condition of all the relay protection elements.

Installation

Mounting

The optional 825-PMB Modbus Communication Card occupies the communication expansion slot [C] in the 825-P Modular Protection System.

Wiring

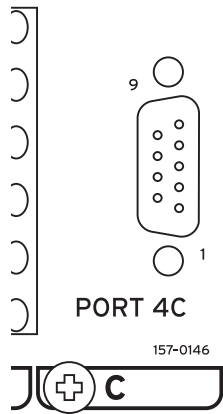
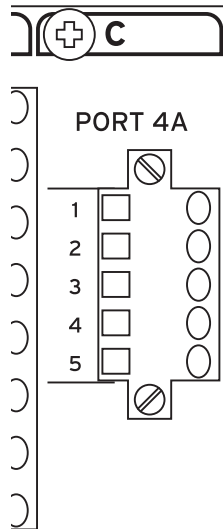

Table 61 - RS 485 Connections (top to bottom)

Pin	Pin Function	Definition
1	Dx+	Transmit Data (Positive)
2	Dx-	Transmit Data (Negative)
3	Rx+	Receive Data (Positive)
4	Rx-	Receive Data (Negative)
5	SH	Shield

RS 232 Connections

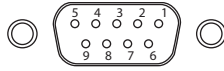

Table 62 - RS 232 Connections

Pin	Pin Function	Definition
1	+5V DC	
2	RxD	Receive Data
3	TxD	Transmit Data
4	NC	No Connection
5	GND	Signal Ground
6	GND	Signal Ground
7	NC	No Connection
8	RTS	Request to Send
9	CTS	Clear to Send

Figure 46 - Example of wiring between a MicroLogix PLC Advanced Interface Converter (AIC) and the 825-PMB, Modbus Option Card.

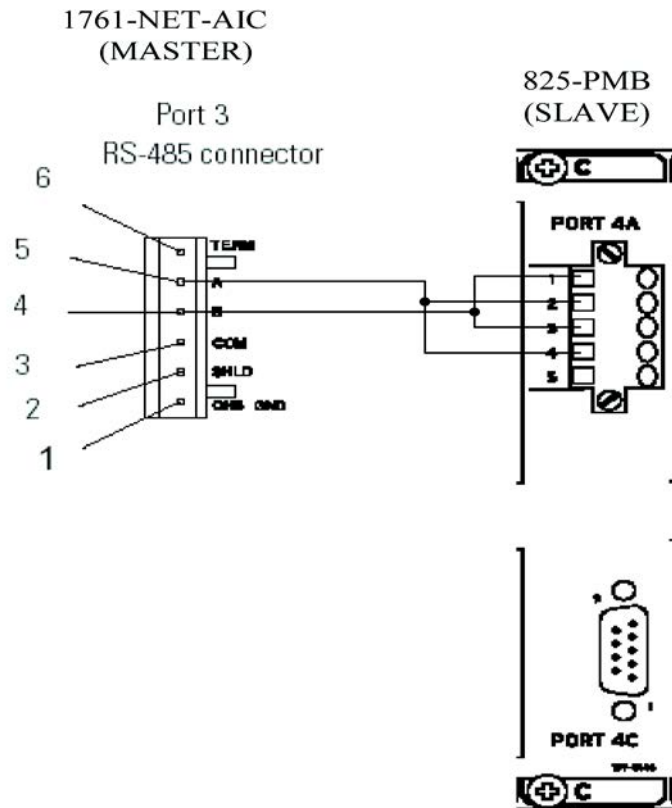
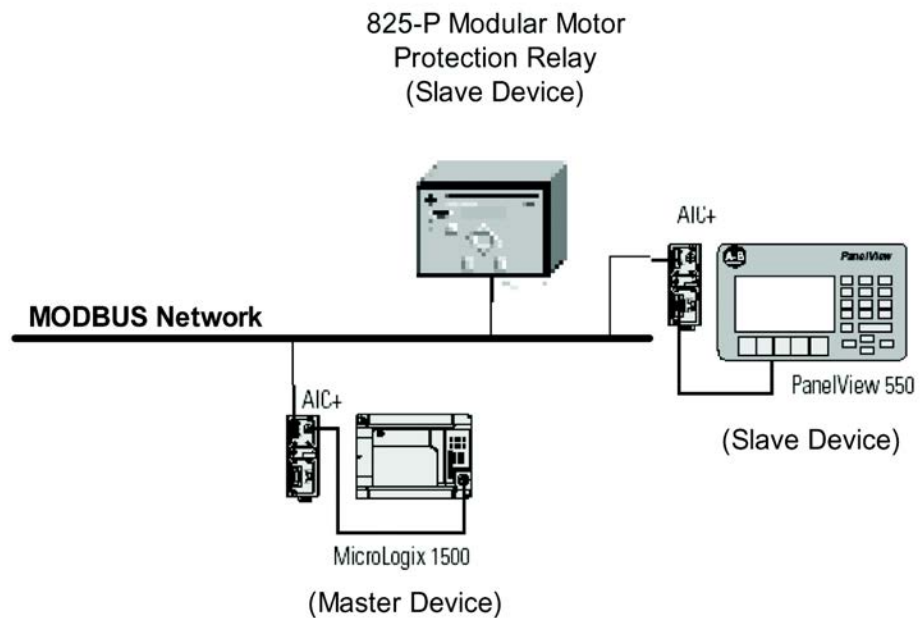

Figure 47 - Example of Modbus network consisting of a MicroLogix 1500 PLC as the Master device and an 825-P and PanelView 550 as the Slave devices.



Commissioning

The Modbus communication card (Port 4) can be configured through the front panel or serial port using the following settings. Front panel access uses the following path: MAIN > Set/Show > Port > Port 4

Table 63 - Modbus communication card settings

Setting Prompt	Setting Range	Factory Default
COMM INTERFACE	232, 485	232
PROTOCOL	ASC, MOD	MOD
SPEED	300 ... 38,400 bps	19,200
PARITY	0, E, N	N
MODBUS SLAVE ID	1 ... 248	248

The following table provides settings to use for each communication card:

Table 64 - Communication card settings

Setting Prompt	Setting Range	DeviceNet	Modbus	Empty
COMM INTERFACE	232, 485	232	232	232
PROTOCOL	ASC, MOD	MOD	MOD	MOD
SPEED	300 ... 38,400 bps	19,200	19,200	19,200
PARITY	0, E, N	N	N	N
MODBUS SLAVE ID	1 ... 248	248	1 to 247	1

Modbus Queries

Modbus RTU master devices initiate all exchanges by sending a query. The query consists of the fields shown in Table 65.

Table 65 - Modbus Query Fields

Field	Number of Bytes
Slave Device Address	1 byte
Function Code	1 byte
Data Region	0...250 bytes
Cyclical Redundancy Check (CRC)	2 bytes

The 825-P SLAVEID setting defines the device address. Set this value to a unique number for each device on the Modbus network. For Modbus communication to operate properly, no two slave devices may have the same address.

The cyclical redundancy check detects errors in the received data. If an error is detected, the relay discards the packet.

Modbus Responses

The slave device sends a response message after it performs the action requested in the query. If the slave cannot execute the command for any reason, it sends an error response. Otherwise, the slave device response is formatted similarly to the query including the slave address, function code, data (if applicable), and a cyclical redundancy check value.

Supported Modbus Function Codes

The 825-P supports the Modbus function codes shown in Table 66.

Table 66 - 825-P Modbus Function Codes

Codes	Description
03h	Read Holding Registers
06h	Preset Single Register
10h	Preset Multiple Registers
60h	Read Parameter Information
61h	Read Parameter Text
62h	Read Enumeration Text
7Dh	Encapsulate Modbus Packet With Control
77Eh	NOP

Modbus Exception Responses

The 825-P sends an exception code under the conditions described in Table 67.

Table 67 - 825-P Modbus Exception Codes

Exception Code	Error Type	Description
1	Illegal Function Code	The received function code is either undefined or unsupported.
2	Illegal Data Address	The received command contains an unsupported address in the data field.
3	Illegal Data Value	The received command contains a value that is out of range.
4	Device Error	The 825-P is in the wrong state for the requested function. This also stands for Service Failure for DeviceNet interface applications. The relay is unable to perform the requested action (i.e., cannot write to a read-only register).
6	Busy	The 825-P is unable to process the command at this time a resource is busy.
8	Memory Error	Checksum error on stored data.

In the event that any of the errors listed in Table 67 occur, the relay assembles a response message that includes the exception code in the data field. The relay sets the most significant bit in the function code field to indicate to the master that the data field contains an error code, instead of the requested data.

Cyclical Redundancy Check

The 825-P calculates a 2-byte CRC value using the device address, function code, and data region. It appends this value to the end of every Modbus response. When the master device receives the response, it recalculates the CRC. If the calculated CRC matches the CRC sent by the 825-P, the master device uses the data received. If there is not a match, the check fails and the message is ignored. The devices use a similar process when the master sends queries.

03h Read Holding Register Command

Use function code 03h to read directly from the Modbus Register Map shown in Appendix B.

You may read a maximum of 125 registers at once with this function code. Most masters use 4X references with this function code. If you are accustomed to 4X references with this function code, for five-digit addressing, add 40001 to the standard database address.

Table 68 - 03h Read Holding Register Command (Sheet 1 of 2)

Bytes	Field
Requests from the master must have the following format:	
1 byte	Slave Address
1 byte	Function Code (03h)
2 bytes	Starting Register Address
2 bytes	Number of Registers to Read
2 bytes	CRC-16
A successful response from the slave will have the following format:	
1 byte	Slave Address
1 byte	Function Code (03h)
1 byte	Bytes of data (<i>n</i>)
<i>n</i> bytes	Data (2...250)
2 bytes	CRC-16

The relay responses to errors in the query are shown in Table 69.

Table 69 - Responses to 03h Read Holding Register Query Errors

Error	Error Code Returned	Communication Counter Increments
Illegal register to read	Illegal Data Address (02h)	Invalid Address
Illegal number of registers to read	Illegal Data Value (03h)	Illegal Register
Format error	Illegal Data Value (03h)	Bad Packet Format

TIP The first holding register (parameter) for the 825-P ia 1. Some Modbus masters use 0 as the first holding register. This can give the appearance of data being offset by one register.

06h Preset Single Register Command

The 825-P uses this function to allow a Modbus master to write directly to a database register. Refer to the Modbus Register Map in Appendix B for a list of registers that can be written using this function code. If you are accustomed to 4X references with this function code, for six-digit addressing, add 400001 to the standard database addresses.

In Table 70, the command response is identical to the command request.

Table 70 - 06h Preset Single Register Command

Bytes	Field
Requests from the master must have the following format:	
1 byte	Slave Address
1 byte	Function Code (06h)
2 bytes	Register Address
2 bytes	Data
2 bytes	CRC-16

The relay responses to errors in the query are shown in Table 71.

Table 71 - Responses to 06h Preset Single Register Query Errors

Error	Error Code Returned	Communication Counter Increments
Illegal register address	Illegal Data Address (02h)	Invalid Address Illegal Write
Illegal register value	Illegal Data Value (03h)	Illegal Write
Format error	Illegal Data Value (03h)	Bad Packet Format

10h Preset Multiple Registers Command

This function code works much like code 06h, except that it allows you to write multiple registers at once, up to 100 per operation. If you are accustomed to 4X references with the function code, for six-digit addressing, simply add 400001 to the standard database addresses.

Table 72 - 10h Preset Multiple Registers Command

Bytes	Field
Requests from the master must have the following format:	
1 byte	Slave Address
1 byte	Function Code (10h)
2 bytes	Starting Address
2 bytes	Number of Registers to Write
1 byte	Bytes of Data (n)
n bytes	Data
2 bytes	CRC-16
A successful response from the slave will have the following format:	
1 byte	Slave Address
1 byte	Function Code (10h)

Bytes	Field
2 bytes	Starting Address
2 bytes	Number of Registers
2 bytes	CRC-16

The relay responses to errors in the query are shown below:

Table 73 - 10h Preset Multiple Registers Query Error Messages

Error	Error Code Returned	Communication Counter Increments
Illegal register to set	Illegal Data Address (02h)	Invalid Address Illegal Write
Illegal number of registers to set	Illegal Data Value (03h)	Illegal Write
Incorrect number of bytes in query data region	Illegal Data Value (03h)	Bad Packet Format Illegal Write
Invalid register data value	Illegal Data Value (03h)	Illegal Write

60h Read Parameter Information Command

The 825-P uses this function to allow a Modbus master to read parameter information from the relay. One parameter (setting) is read in each query.

Table 74 - 60h Read Parameter Information Command

Bytes	Field
Requests from the master must have the following format:	
1 byte	Slave Address
1 byte	Function Code (60h)
2 bytes	Parameter Number
2 bytes	CRC-16
A successful response from the slave will have the following format:	
1 byte	Slave Address
1 byte	Function Code (60h)
2 bytes	Parameter Number
1 byte	Parameter Descriptor
1 byte	Parameter Conversion
2 bytes	Parameter Minimum Settable Value
2 bytes	Parameter Maximum Settable Value
2 bytes	Parameter Default Value
2 bytes	CRC-16

The Parameter Descriptor field is defined in Table 75:

Table 75 - 60h Read Parameter Descriptor Field Definition

Bit	Name	Description
0	RO: Read-only	1 when the setting is read-only
1	H: Hidden	1 when the setting is hidden
2	DBL: 32-bit	1 when the following setting is a fractional value of this setting
3	RA: RAM-only	1 when the setting is not saved in nonvolatile memory
4	RR: Read-only if running	1 when the setting is read-only if in running/operational state
5	P: Power Cycle or Reset	1 when the setting change requires a power cycle or reset
6	0	Reserved
7	Extend	Reserved to extend the descriptor table

The Parameter Conversion field is defined in Table 76:

Table 76 - 60h Read Parameter Conversion Field Definition

Conversion Value	Type	Multiplier	Divisor	Offset	Base
0	Boolean	1	1	0	1
1	Unsigned Integer	1	1	0	1
2	Unsigned Integer	1	10	0	1
3	Unsigned Integer	1	100	0	1
4	Unsigned Integer	1	1000	0	1
5	Hexidecimal	1	1	0	1
6	Integer	1	1	0	1
7	Integer	1	10	0	1
8	Integer	1	100	0	1
9	Integer	1	1000	0	1
10	Enumeration	1	1	0	1
11	Bit Enumeration	1	1	0	1

Calculate the actual (not scaled) value of the parameter (setting) using Equation 2:

$$\text{value} = \frac{(\text{Parameter Value} + \text{Offset}) \bullet \text{Multiplier} \bullet \text{Base}}{\text{Divisor}} \quad \text{Equation 1}$$

Calculate the scaled setting value using Equation 2:

$$\text{value} = \frac{\text{value} \bullet \text{Divisor}}{\text{Multiplier} \bullet \text{Base}} - \text{Offset} \quad \text{Equation 2}$$

The relay response to errors in the query are shown Table 77:

Table 77 - Responses to 60h Read Parameter Information Query Errors

Error	Error Code Returned	Communication Counter Increments
Illegal parameter to read	Illegal Data Value (03h)	Illegal Register

61h Read Parameter Text Command

The 825-P uses this function to allow a Modbus master to read parameter text from the relay. One parameter text (setting name) is read in each query.

Table 78 - 61h Read Parameter Text Command

Bytes	Field
Requests from the master must have the following format:	
1 byte	Slave Address
1 byte	Function Code (61h)
2 bytes	Parameter Number
2 bytes	CRC-16
A successful response from the slave will have the following format:	
1 byte	Slave Address
1 byte	Function Code (61h)
2 bytes	Parameter Number
16 bytes	Parameter Text (setting name)
4 bytes	Parameter Unites (e.g., Amps)
2 bytes	CRC-16

The relay responses to errors in the query are shown below:

Table 79 - 61h Read Parameter Text Query Error Messages

Error	Error Code Returned	Communication Counter Increments
Illegal parameter to read	Illegal Data Value (03h)	Illegal Register Illegal Write

62h Read Enumeration Text Command

The 825-P uses this function to allow a Modbus master to read parameter enumeration or bit enumeration values (setting lists) from the relay. One parameter enumeration is read in each query.

Table 80 - 62h Read Enumeration Text Command

Bytes	Field
Requests from the master must have the following format:	
1 byte	Slave Address
1 byte	Function Code (62h)
2 bytes	Parameter Number
1 byte	Enumeration Index
2 bytes	CRC-16
A successful response from the slave will have the following format:	
1 byte	Slave Address
1 byte	Function Code (62h)
2 bytes	Parameter Number
1 byte	Enumeration Index
16 bytes	Enumeration Text
2 bytes	CRC-16

The relay responses to errors in the query are shown below:

Table 81 - 61h Read Parameter Enumeration Text Query Error Messages

Error	Error Code Returned	Communication Counter Increments
Illegal parameter to read	Illegal Data Value (03h)	Illegal Register

7Dh Encapsulated Packet With Control Command

The 825-P uses this function to allow a Modbus master to perform control operations and another Modbus function with one query. This command will be transmitted periodically to achieve high-speed I/O processing and also serve as a heartbeat between the communication option card and the main board.

Bytes	Field
Requests from the master must have the following format:	
1 byte	Slave Address
1 byte	Function Code (7Dh)
2 bytes	Subfunction (2000h)
1 byte	Modbus Function
<i>n</i> bytes	Optional Data to Support Modbus Function (0...250)
2 bytes	CRC-16
A successful response from the slave will have the following format:	
1 byte	Slave Address
1 byte	Function Code (7Dh)
2 bytes	Subfunction (2100h or 2101h)
1 byte	Function Code (7Eh)
<i>n</i> bytes	Optional Data to Support Modbus Function (0...250)
2 bytes	CRC-16

The format of the relay responses to errors in the query is shown in Table 82.

Table 82 - 7Dh Encapsulated Packet Query Errors

Bytes	Field
Requests from the master must have the following format:	
1 byte	Slave Address
1 byte	Function Code (7Dh)
2 bytes	Subfunction (2100h or 2101h)
1 byte	Function Code (7Eh)
1 byte	Function Error Code
2 bytes	CRC-16

7Eh NOP Command

This function code allows a Modbus master to perform a control operation and is used inside of the 7Dh when no regular Modbus query is required.

Table 83 - 17Eh NOP Command

Bytes	Field
Requests from the master must have the following format:	
1 byte	Slave Address
1 byte	Function Code (7Eh)
2 bytes	CRC-16
A successful response from the slave will have the following format:	
1 byte	Slave Address
1 byte	Function Code (7Eh)
2 bytes	CRC-16
An example of a 7D message using 7E will have the following format:	
1 byte	Slave Address
1 byte	Function Code (7Dh)
2 bytes	Subfunction (2100h)
2 bytes	Subfunction (2101h)
1 byte	Function Code (7Eh)
2 bytes	CRC-16

Modbus Password Control and Parameter Modification

The 825-P parameters MID, TID, Password, and the User Map Registers are settable via Modbus. Any settable parameter or reset that requires a valid password write will timeout 15 minutes after the last valid write to any of these restricted registers.

Writing the password for access level change requires the 10h (preset multiple register) command. Changing the password can be done one register at a time. A device error is returned during settings save if the relay is disabled or settings are being changed on another port. Device error is also returned for attempts to write to settable values if the access level has not been changed.

To enable modification of the settable parameters, a valid Access Level E (EAC) password must be written to the password registers using function code 10h. Note changing the password will change the password for all ports.

Once a valid password has been written, then the values may be changed using standard single or multiple register writes (06h or 10h). Until a command is issued to save or discard the settings, the value returned when reading the settable parameter registers is a temporary copy.

To save the modified parameters, write a 0x0001 to the Save Settings register of the Control I/O region. This is the only method that saves the changes.

To discard settings, either write a 0x0001 to the Discard Settings register of the Control I/O region, write a 0x0001 to the Drop Access Level register of the Control I/O region or wait fifteen minutes since last write for access level timeout.

Modbus Serialized Events Recording Register Operation

To obtain Serialized Events Recording (SER) records using the Modbus register map perform the following steps.

1. Write the date and time for the first desired record to the Start Record Time/Date registers of the SER region of the map.
2. Read the Number of Records Available register to determine how many SER records are available on or after the selected date and time. Ten records are available for reading from the SER region of the map.
3. Write to the Selected Starting Record register to select additional records from the number available.

For example, if the Number of Records available is 25, write 11 to the Selected Starting Record to read records 11...20.

Modbus Load Profile Register Operation

To read load profile data from the 825-P using the Modbus map, perform the following steps.

1. Read the Load Profile 1 Name to Load Profile 12 Name registers from the Product Information region of the map.

These names are returned as a NULL terminated ASCII string and provide the human readable label for the profiled data. If the load profile channel is unused, then the associated label is an empty string.

2. Write the date and time for the first desired record to the Start Record Time/Date registers of the Load Profile region of the map. Up to 100 records are available on or after the selected date and time. Channels that are not profiling data returns a reserved value when read (see Table 84).

Table 84 - Modbus Conversion

Conversion	Description	Reserved Value
INT	Value ranges = -32767 ... 32767	0x8000
INT10	INT with scale factor of 10 (divide by 10 to obtain value)	0x8000
INT100	INT with scale factor of 100 (divide by 100 to obtain value)	0x8000
INT1000	INT with scale factor of 1000 (divide by 1000 to obtain value)	0x8000

Conversion	Description	Reserved Value
UINT	Value ranges from 0 to 65535	0x8000
UINT10	UINT with scale factor of 10 (divide by 10 to obtain value)	0x8000
UINT100	UINT with scale factor of 100 (divide by 100 to obtain value)	0x8000
UINT1000	UINT with scale factor of 1000 (divide by 1000 to obtain value)	0x8000
LONG	Value ranges = -2147483647...2147483647, most significant word in lower address register	0x80000000
LONG10	LONG with scale factor of 10 (divide by 10 to obtain value)	0x80000000
LONG100	LONG with scale factor of 100 (divide by 100 to obtain value)	0x80000000
LONG1000	LONG with scale factor of 1000 (divide by 1000 to obtain value)	0x80000000
BITMAP	A bitmapped value	
ENUM	An enumerated value	
STRING	A null terminated ASCII string	

Testing & Troubleshooting

Overview

Relay testing is typically divided into two categories. Relay tests are performed:

- when the relay is installed or commissioned **and**
- periodically once the relay is in service

This chapter provides information on both types of testing for the 825-P relay. Because the 825-P is equipped with extensive self-tests, traditional periodic test procedures can be eliminated or reduced.

If a problem occurs during either commissioning or periodic tests, this chapter provides a guide to isolating and correcting the problem.

Testing

Commissioning Tests

Introduction

Each 825-P is fully calibrated and functionally tested prior to shipment. This helps to ensure that you receive a relay that operates correctly and accurately.

Commissioning tests must verify that the relay is properly connected to the motor and all auxiliary equipment. Verify control signal inputs and outputs. Use an AC connection check to verify that the relay current and voltage inputs are of the proper magnitude and phase rotation.

Brief functional tests ensure that the relay settings are correct. It is not necessary to test every element, timer, and function in these tests.

The following procedure is a guideline to help you enter settings into the 825-P and to verify that it is properly connected. Modify the procedure as necessary to conform to your standard practices. Use this procedure at initial relay installation; you do not need to repeat it unless major changes are made to the relay electrical connections.

Required Equipment

Before proceeding with commissioning tests, ensure the following equipment is present and properly installed as stated.

- 825-P Relay — installed and connected according to your protection design

- PC with Serial Port, MPS Explorer software, and serial communication cable
- Terminal Emulation Software
- Serial Communication Cable
- AC and DC Elementary Schematics
- Wiring Diagrams (for this relay installation)
- Continuity Tester
- Protective Relay AC Test Source
 - Minimum: single-phase voltage and current with phase angle control
 - Preferred: three-phase voltage and current with phase angle control

Procedure

1. Remove the control voltage and AC signals from the 825-P by opening the appropriate breakers or removing fuses.
2. Isolate the relay trip contact.
3. Verify the correct AC and DC connections by performing point-to-point continuity checks on the associated circuits.
4. Apply AC or DC control voltage to the relay.
5. After the relay is energized, the front panel green ENABLE LED illuminates.
6. Connect a PC to the relay using an appropriate serial cable.
7. Start the MPS Explorer software and establish communication with the relay.
8. Set the correct relay time and date using either the front panel or MPS Explorer software.
9. Enter the relay settings for your application.
10. If you are connecting an external RTD scanner, follow the substeps below; otherwise continue with Step 11.
 - a. Connect the fiber optic cable to the module fiber optic output.
 - b. Plug the relay end of the fiber optic cable into the relay fiber optic input.
11. Verify the relay AC connections.

12. Connect the AC test source current or voltage transformers to the relay side of the open breaker or contactor.

NOTE: If voltage transformers are used: Apply the AC voltage signal to the relay side of an open disconnect block, which is located between the secondary side of the voltage transformer and the relay.

If the relay is set to accept phase-to-ground voltages (DELTA_Y = Wye): Set current and/or voltage phase angles as shown in Figure 48.

If the relay is set to accept delta voltages (DELTA_Y = Delta): Set the current and/or voltage phase angles as shown in Figure 49.

13. Apply the rated current.

NOTE: If current transformers are used: Apply the AC current signal to the converter's module side of an open CT-shorting disconnect block, which is located between the secondary side of the current transformer and the MCM converter module.

14. If the relay is equipped with voltage inputs, apply rated voltage for your application.
15. Use the front panel METER VALUES > INSTANTANEOUS METER function or serial port METER command to verify that the relay is measuring the magnitude and phase angle of both voltage and current correctly. Take into account the relay PTR and CTR1 settings and the fact that the quantities are displayed in primary units.
16. If you are using a core balance current transformer, apply a single-phase current (A-Phase) as described in Step 11. **Do not apply voltage.**
17. Verify that the relay is measuring the magnitude and phase angle of the GF Current-Core Balance correctly.

The expected magnitude is (Applied Phase Current) • (CTRN). The expected phase angle is zero.

Figure 48 - Three-Phase Wye AC Connections

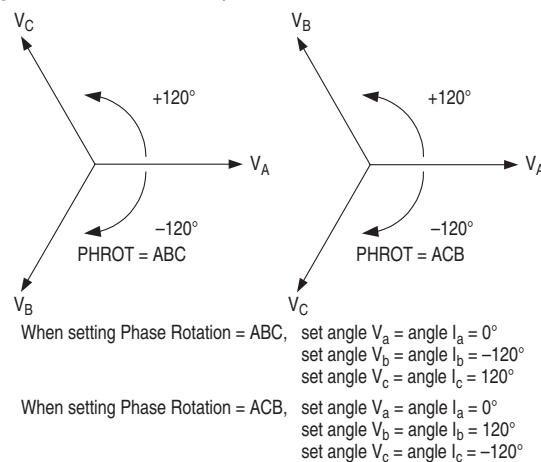
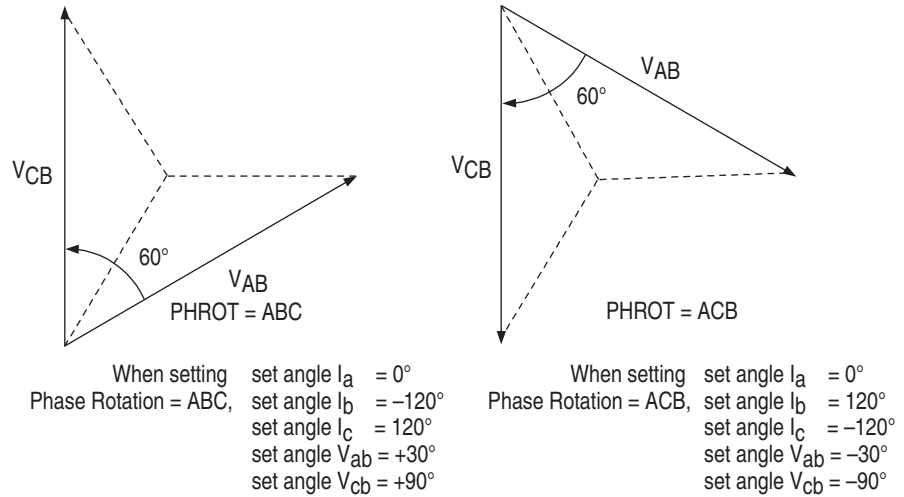

Figure 49 - Three-Phase Open-Delta AC Connections



18. Verify the control input connections are properly seated. Check the control input status in the relay using the front panel MAIN > TARGETS > ROW 9 function. As the appropriate voltage is applied across input common and input, its corresponding position in Row 9 changes from zero to one.
19. Verify the output contact operation by performing the following steps:
 - a. Disconnect the MCM converter module cable from the connector on the rear panel of the 825-P. The 825-P trip relay and AUX1 (alarm) relay will be energized once the front panel displays the following output:

```
STATUS FAIL
MCM/CWE Failure
```
 - b. Set AUX2C to equal: 0 0 0 0 0 0 1. This will cause the AUX2 contact to close.
 - c. Repeat this process for AUX3...AUX6, if present. Ensure that each contact closure produces the result required in its associated annunciation, control, or trip circuit.
 - d. Reconnect the MCM converter module cable to the 825-P.
 - e. Select STATUS from the front panel display menu and press the Enter push button. The front panel displays the following:

```
Confirm Hardware
Config (Enter)
```
 - f. Press \leftarrow . The front panel displays the following:

```
Accept Config?
Yes No
```
 - g. Select Yes, then press the Enter push button. The front panel displays the following:

```
Config Accepted
Enter to Restart
```
 - h. Press \leftarrow . The 825-P will restart and the ENABLE LED will illuminate to indicate that the MCM module is recognized.

20. Perform any protection element tests using the individual element test procedures in Selected Functional Tests on page 151.

Perform the tests until it is proven that the relay operates as intended. Exhaustive element performance testing is not necessary for commissioning.

21. Connect the relay for tripping duty.
22. Verify that any settings changed during the tests performed in Step 19 and Step 20 are changed back to the correct values for your application.
23. Prepare the relay for operation by clearing the relay data buffers using MPS Explorer software.

Clearing the relay buffers prevents data generated during commissioning testing from being confused with operational data collected later.

24. Start the motor only when it is safe to do so.
25. Verify the following AC quantities using the front panel METER or serial port METER command:
- phase current magnitudes are nearly equal and
 - phase current angles are balanced, have proper phase rotation, and have the appropriate phase relationship to the phase voltages.
26. If your relay is equipped with voltage inputs, verify the following:
- phase voltage magnitudes are nearly equal.
 - Phase voltage phase angles are balanced and have proper phase rotation.

The 825-P relay is now ready for continuous service.

Selected Functional Tests

Phase Current Measuring Accuracy

1. Connect the current source to the MCM converter module, as shown in Figure 50.

Figure 50 - Current Source Connections

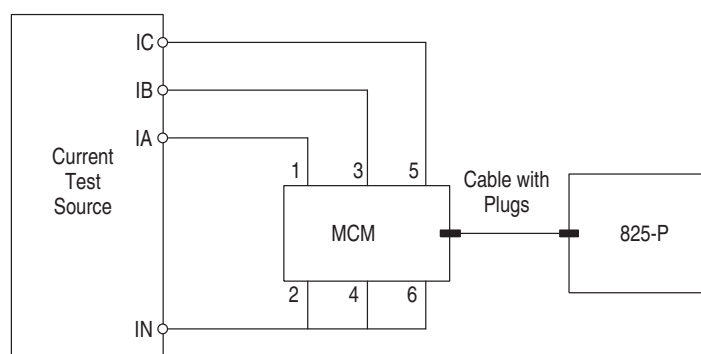

2. Using the front panel or MPS Explorer software, record the Phase CT Ratio and Phase Rotation setting values.
3. Set the phase current angles to apply balanced three-phase currents in accordance with the Phase Rotation setting. Refer to Figure 48 on page 149.
4. Set each phase current magnitude equal to the values listed in Column 1 of Table 85. Use the front panel to view the phase current values. The relay displays the applied current magnitude times the CT Ratio setting.

Table 85 - Phase Current Measuring Accuracy

I Applied (A secondary)	Expected Reading $CTR1 \times I$	A-Phase Reading (A primary)	B-Phase Reading (A primary)	C-Phase Reading (A primary)
Minimum				
Mid-range				
Maximum				

For the minimum, mid-range, and maximum values, refer to the I_e setting range for a given MCM converter module. These converter module current ranges are:

- 825-MCM2 (0.5...2.5 A)
- 825-MCM5 (1.0...5.0 A)
- 825-MCM20 (2.5...20 A)
- 825-MCM180 (20...180 A)
- 825-MCM420 (160...420 A)
- 825-MCM630N (160...630 A)

Current Unbalance Element Accuracy

1. Connect the current source to the MCM module as shown in Figure 48.
2. Using the front panel SET/SHOW function or MPS Explorer software, record the Phase CT Ratio, Phase Rotation, and Motor FLA (I_e) setting values.
3. Set the phase current angles to apply balanced three-phase currents in accordance with the Phase Rotation setting. See Figure 48.
4. Apply the appropriate magnitude for each phase current as shown in column 1 of Table 86

Table 86 - Current Unbalance Measuring Accuracy

I Applied (A secondary)	Expected Reading (%)	Actual Reading (%)
$ IA = 0.9 \cdot FLA$	7%	
$ IB = FLA$		
$ IC = FLA$		
$ IA = 0.75 \cdot FLA$	17%	
$ IB = FLA$		
$ IC = FLA$		

Table 86 - Current Unbalance Measuring Accuracy

 Applied (A secondary)	Expected Reading (%)	Actual Reading (%)
$ I_A = FLA$	12%	
$ I_B = 1.2 \cdot FLA$		
$ I_C = 1.2 \cdot FLA$		
$ I_A = 0.9 \cdot FLA$	13%	
$ I_B = 1.1 \cdot FLA$		
$ I_C = 1.1 \cdot FLA$		

Power and Power Factor Measuring Accuracy

The following tests assume use of an MCM2, MCM5, or MCM20 converter module.

Wye-Connected Voltages

Perform the following steps to test wye-connected voltages:

1. Connect the current source to the MCM module, as shown in Figure 50.
2. Connect the voltage source to the 825-P, as shown in Figure 51. Make sure that Xfmt Connection = Wye.

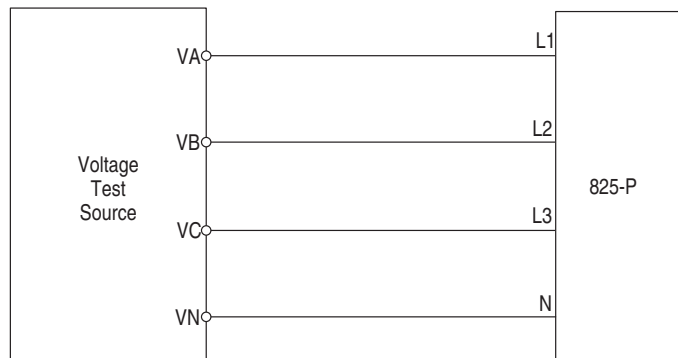
Figure 51 - Wye Voltage Source Connections

3. Using the front panel SET/SHOW or MPS Explorer software, record the Phase CT Ratio, Phase VT Ratio, and Phase Rotation setting values.
4. Apply the current and voltage quantities shown in Column 1 of Table 87. Values are given for Phase Rotation = ABC and Phase Rotation = ACB.
5. Use the front panel METER function or MPS Explorer software to verify the results.

Table 87 - Power Quantity Accuracy — Wye Voltages

Applied Currents and Voltages	Real Power (kW)	Reactive Power (kVAR)	Power Factor (pf)
PHROT = ABC $I_a = 2.5 \angle -26$ $I_b = 2.5 \angle -146$ $I_c = 2.5 \angle +94$ $V_a = 67 \angle 0$ $V_b = 67 \angle -120$ $V_c = 67 \angle +120$	Expected: $P = 0.4523 \cdot \text{CTR1} \cdot \text{PTR}$ Measured:	Expected: $Q = 0.2211 \cdot \text{CTR1} \cdot \text{PTR}$ Measured:	Expected: $\text{pf} = 0.90 \text{ lag}$ Measured:
PHROT = ACB $I_a = 2.5 \angle -26$ $I_b = 2.5 \angle +94$ $I_c = 2.5 \angle -146$ $V_a = 67 \angle 0$ $V_b = 67 \angle +120$ $V_c = 67 \angle -120$	Expected: $P = 0.4523 \cdot \text{CTR1} \cdot \text{PTR}$ Measured:	Expected: $Q = 0.2211 \cdot \text{CTR1} \cdot \text{PTR}$ Measured:	Expected: $\text{pf} = 0.90 \text{ lag}$ Measured:

Delta-Connected Voltages

Perform the following steps to test delta-connected voltages:

1. Connect the current source to the MCM module, as shown in Figure 50 on page 151.
2. Connect the voltage source to the 825-P, as shown in Figure 52. Make sure that Xfmr Connection=Delta.

Figure 52 - Delta Voltage Source Connections

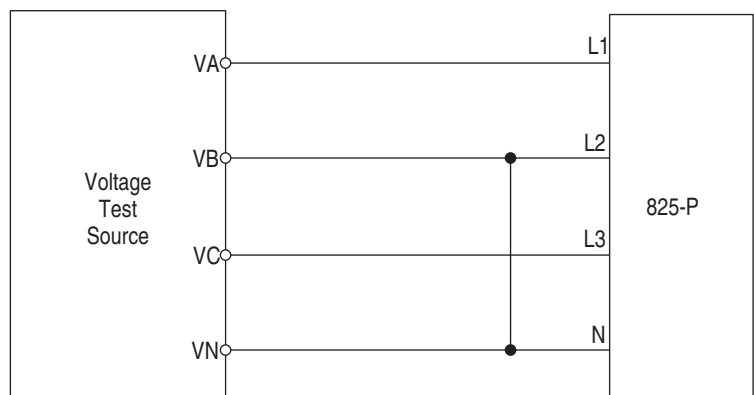

3. Use the front panel SET/SHOW or MPS Explorer software to record the Phase CT Ratio, Phase VT Ratio, and Phase Rotation setting values.
4. Apply the current and voltage quantities shown in Column 1 of Table 88. Values are given for Phase Rotation = ABC and Phase Rotation = ACB.
5. Use the front panel METER or MPS Explorer software to verify the results.

Table 88 - Power Quantity Accuracy — Delta Voltages

Applied Currents and Voltages	Real Power (kW)	Reactive Power (kVAR)	Power Factor (pf)
PHROT = ABC Ia = 2.5 ∠-26 Ib = 2.5 ∠-146 Ic = 2.5 ∠+94 Vab = 120 ∠+30 Vbc = 120 ∠-90	Expected: P = 0.4677 • CTR1 • PTR Measured:	Expected: Q = 0.2286 • CTR1 • PTR Measured:	Expected: pf = 0.90 lag Measured:
PHROT = ACB Ia = 2.5 ∠-26 Ib = 2.5 ∠+94 Ic = 2.5 ∠-146 Vab = 120 ∠-30 Vbc = 120 ∠+90	Expected: P = 0.4677 • CTR1 • PTR Measured:	Expected: Q = 0.2286 • CTR1 • PTR Measured:	Expected: pf = 0.90 lag Measured:

Periodic Tests (Routine Maintenance)

Due to the 825-P being equipped with extensive self-tests, the most effective maintenance task is monitoring the front panel messages after a self-test failure. In addition, review each relay event report generated by a fault. Such reviews frequently reveal problems with equipment external to the relay, such as instrument transformers and control wiring.

The 825-P does not require specific routine tests, but your operation standards can require some degree of periodic relay verification. If you need or wish to perform periodic relay verification, the following checks are recommended.

Relay Status Verification

Use the front panel STATUS or MPS Explorer software to verify that the relay self-tests have not detected any WARN or FAIL conditions.

Meter Verification

Verify that the relay is correctly measuring current and voltage (if included) by comparing the relay meter readings to separate external meters.

Control Input Verification

Using the front panel MAIN > TARGETS > ROW 9 function, check the control input status in the relay. As the appropriate voltage is applied across input and input common, its corresponding position in Row 9 changes from zero to one.

Contact Output Verification

Disconnect the MCM converter module cable from the connector on the rear panel of the 825-P. Use the front panel MAIN > TARGETS > ROW 3 function to check that MCM/CWEFLT, Bit 0, is equal to one. Use MPS Explorer software to make TRIPC = 0 0 0 0 0 0 1 which closes the Trip contact.

Set AUX2C = 0 0 0 0 0 0 1. This will cause the AUX2 contact to close. Repeat the process for AUX3...AUX6, if present. Ensure that each contact closure produces the result that is needed in its associated annunciation, control, or trip circuit [remove control power to close the AUX1 (Alarm) contact].

Self-Tests

The 825-P runs a variety of self-tests. As shown in Table 89, when the relay detects certain self-test failures, the Critical Alarm Status is latched. A latched Critical Alarm Status closes the Trip contact and displays the associated message on the front panel.

When the Critical Alarm Status column in Table 89 shows Not Latched, the trip contact will not close because of the self-test failure. However, the associated message (if present) is displayed on the front panel.

All relay self-test failure messages are automatically sent to the serial port.

Table 89 - Relay Self-Tests (Sheet 1 of 2)

Self-Test	Description	Limits	Protection Disabled on Failure	Critical Alarm Status	Front Panel Message on Failure
External RAM	Performs a read/write test on system RAM		Yes	Latched	External RAM FAILED
Internal RAM	Performs a read/write test on CPU RAM		Yes	Latched	Coldfire RAM FAILED
CR_RAM	Performs a checksum test on the active copy of settings	Checksum	Yes	Latched	CR_RAM FAILED
Code Flash	Checksum is computed on code base	Checksum	Yes	Latched	PROGRAM MEMORY FAILED
Mainboard EEPROM	Checksum is computed on critical data	Checksum	Yes	Latched	EEPROM FAILED
Data Flash	Checksum is computed on critical data	Checksum	Yes	Latched	FLASH FAILED
Front Panel	Check if ID register matches expected		No	Not Latched	
Voltage Board	Check if ID register matches part number		Yes	Latched	VT CALIBRATION FAILED
Current Board	Check if ID register matches part number		Yes	Latched	CT CALIBRATION FAILED
I/O Board	Check if ID register matches part number		Yes	Latched	I/O BOARD FAILURE
DeviceNet Board	DeviceNet card does not respond in 500 ms.		Yes	Latched	DEVICENET BOARD FAILURE
CPU Exception Vector	CPU error		Yes	Latched	Vector nn
Loss of MCU Crystal	Clock stopped		Yes	Latched	CLOCK STOPPED
Current Board A/D Offset	Measure DC offset at each input channel	50 mV	No	Not Latched	
Voltage Board A/D Offset	Measure DC offset at each input channel	50 mV	No	Not Latched	
+3.3V Warn	Measure +3.3V power supply	<3.43V >3.13V	No	Not Latched	
+3.3V Fail	Measure +3.3V power supply	<3.07V >3.53V	Yes	Latched	+3.3V FAIL
+5V Warn	Measure +5V power supply	<5.2V >4.8V	No	Not Latched	

Table 89 - Relay Self-Tests (Sheet 2 of 2)

Self-Test	Description	Limits	Protection Disabled on Failure	Critical Alarm Status	Front Panel Message on Failure
+5V Fail	Measure +5V power supply	<5.4V >4.65V	Yes	Latched	+5V FAIL
+2.5V Warn	Measure +2.5V power supply	<2.60V >2.42V	No	Not Latched	
+2.5V Fail	Measure +2.5V power supply	<2.68V >2.32V	Yes	Latched	+2.5V FAIL
+3.75V Warn	Measure +3.75 power supply	<3.90V >3.60V	No	Not Latched	
+3.75V Fail	Measure +3.75 power supply	<4.02V >3.48V	Yes	Latched	+3.75V FAIL
-1.25V Warn	Measure -1.25V power supply	>-1.27V <-1.20V	No	Not Latched	
-1.25V Fail	Measure -1.25V power supply	>-1.33V <-1.16V	Yes	Latched	-1.25V FAIL
-5V Warn	Measure -5V power supply	>-5.2V <-4.8V	No	Not Latched	
-5V Fail	Measure -5V power supply	>-5.4V <-4.65V	Yes	Latched	-5V FAIL
CT Board A/D Fail	Check received data		Yes	Latched	CT BOARD ADC FAILURE
PT Board A/D Fail	Check received data		Yes	Latched	PT BOARD ADC FAILURE
Clock Battery Warn	Check battery voltage level	< 2.7V	No	Not Latched	CLOCK BATTERY WARN
RTC Chip	Unable to communicate with clock or fails time-keeping test		No	Not Latched	RTC WARN
Temperature Warn	Measure internal relay temperature	>-40 C <+85 C	No	Not Latched	TEMPERATURE WARN
Temperature Fail	Measure internal relay temperature	>+100 C	Yes	Latched	TEMPERATURE FAIL
Mainboard FPGA	Fail if mainboard Field Programmable Gate Array does not accept program		Yes	Latched	FPGA FAIL
MCM/CWE Type	Fail if the detected external converter module does not match the part number		No		MCM/CWE FAIL
Back-plane Comms Diagnostics	Fail if GPSB is busy two processing intervals in a row		Yes	Latched	GPSB FAIL

Troubleshooting

Refer to Table 90 for troubleshooting instructions in particular situations.

Table 90 - Troubleshooting

Problem	Possible Cause	Solution
The relay enable front panel LED is not illuminated.	Input power is not present or a fuse is blown.	Verify that input power is present. Check fuses continuity.
	Self-test failure.	View the self-test failure message on the front panel display.
The relay front panel display does not show characters.	The relay front panel has timed out.	Press the Esc push button to activate the display.
	The relay is de-energized.	Verify input power and fuse continuity.
The relay does not accurately measure voltages or currents.	Wiring error.	Verify input wiring.
	Incorrect Phase CT Ratio, Core B. CT Ratio, or Phase VT Ratio setting.	Verify instrument transformer ratios, connections, and associated settings.
	Voltage neutral terminal (N) is not properly grounded.	Verify wiring and connections.

Table 90 - Troubleshooting

Problem	Possible Cause	Solution
The relay does not respond to commands from a device connected to the serial port.	Cable is not connected.	Verify the cable connections.
	Cable is not the correct type.	Verify the cable pinout.
	The relay or device is at an incorrect baud rate or has another parameter mismatch.	Verify Device software setup.
	The relay serial port has received an XOFF, halting communications.	Type <Ctrl> Q to send the relay XON and restart communications.
The relay does not respond to faults.	The relay is improperly set.	Verify the relay settings.
	Improper test source settings.	Verify the test source settings.
	Current or voltage input wiring error.	Verify input wiring.
	Failed relay self-test.	Use the front panel RELAY STATUS function to view self-test results.
The relay trips on overload sooner than expected.	The phase rotation is improperly set.	Verify phase rotation setting as described in Figure 48 or Figure 49 .
	The FLA is improperly set.	Verify FLA settings.
	The SF is improperly set.	Verify the Service Factor of the motor.

Field Serviceability



ATTENTION: Disconnect or de-energize all external connections before opening this device. Contact with hazardous voltages and currents inside this device can cause electrical shock that can lead to injury or death. Equipment components are sensitive to electrostatic discharge (ESD). Undetectable permanent damage can result if you do not use proper ESD procedures. Ground yourself, your work surface, and this equipment, before removing any cover from this equipment. If your facility is not equipped to work with these components, contact Rockwell Automation about returning this device and related Rockwell Automation equipment for service.

The 825-P firmware can be upgraded in the field (refer to [Chapter 13](#) for firmware upgrade instructions). By monitoring the front-panel messages, the user will be aware of a self-test failure occurrence. By using the metering functions, the user will be aware if the analog front-end (not monitored by relay self-test) is functional.

The only two components that can be replaced in the field are (1) the power supply fuse and (2) the real-time clock (RTC) battery.

Power Supply Fuse Replacement

To replace the power supply fuse, perform the following steps:

1. De-energize the relay.
2. Remove the eight rear panel screws, ground screw, and relay rear panel.
3. Remove the Slot A printed circuit board.
4. Locate the fuse on the board, then remove the fuse from the fuse holder.

5. Replace the fuse with a BUSS 2A/250V ABC (ceramic) or equivalent.
6. Insert the printed circuit board into Slot A.
7. Reinstall the relay rear panel, ground screw, and eight rear panel screws.
8. Energize the relay.

Real-Time Clock (RTC) Battery Replacement

The RTC battery, which is a 3V lithium coin cell battery (Rayovac BR2335 or equivalent), performs the following functions:

- Powers the clock (date and time) if the external power source is lost or removed.
- Retains the thermal memory for the thermal overload function when the power source is lost or removed.
- Operates nominally at room temperature (25°C) for ten years at rated load.
- Experiences a low self-discharge rate when the relay is powered from an external source. Thus, battery life can extend well beyond ten years. The battery cannot be recharged.

To replace the real-time clock battery, perform the following steps:

1. De-energize the relay.
2. Remove the eight rear panel screws, ground screw, and relay rear panel.
3. Remove the Slot B printed circuit board.
4. Locate the battery clip (holder) on the circuit board.
5. Remove the existing battery from beneath the battery clip.
6. Properly dispose of the battery.
7. Install the new battery, 3V lithium coin cell battery (Rayovac BR2335 or equivalent), with the positive (+) side facing up.
8. Insert the printed circuit board into Slot B.
9. Reinstall the relay rear panel, ground screw, and eight rear panel screws.
10. Energize the relay.
11. Set the relay date and time.

Troubleshooting DeviceNet Table 91 - DeviceNet Troubleshooting Procedures

Table 92 -

Network Status LED	Definition	Possible Cause
Off	The device has not completed the initialization, is not on an active network, or may not be powered up.	Check to ensure that the product is wired correctly and configured on the network.
Flashing Green – Red – Off	Power-up LED test.	No action required.
Solid Green	The device is operating in a normal condition, and is communicating to another device on the network.	No action required.
Flashing Green	The device is operating in a normal condition, is online, but with no connection to another device. This is the typical state for new devices.	The device could need to be mapped to a master scanner, placed in a scanlist, or have another device communicate to it.
Flashing Red	Recoverable fault has occurred.	Ensure that the PLC and scanner are operating correctly and that there are no media or cabling issues. Check to see if other networked devices are in a similar state.
Solid Red	The device has detected a major error that has rendered it incapable of communicating on the network (Duplicate MAC ID, Bus off, media issue).	Troubleshooting should be done to ensure that the network is correct (terminators, lengths, etc.) and there is not a duplicate node problem. If other devices on the network appear to be operating fine and power cycling the device does not work, contact Technical Support.
Flashing Red and Green	The device is in a communication faulted state.	Power cycling the device could resolve the problem; however, if the problem continues, it could be necessary to contact Technical Support.
Flashing Red and Green	The device has detected a network access error and is in a communication faulted state. The device has subsequently received and accepted an Identify Communication Faulted Request Protocol message.	This is not a common state for DeviceNet products. Power cycling the device could resolve the problem, however if the problem continues it could be necessary to find out what is causing the problem.

Troubleshooting Device Backplane Communication Table 93 - Device Backplane Communication Troubleshooting Procedures

Table 94 -

Bus Status LED	Definition	Possible Cause
Off	The device is in Power-up mode.	Check to ensure that the product is wired correctly. Confirm that the product has appropriate DeviceNet and control power. Verify that the 825-PDN card is inserted correctly.
Green	The device is operating in a normal condition.	No action required.
Red	The 825-PDN card has lost backplane communications with the 825-P relay.	Confirm product has appropriate DeviceNet and control power.

ASCII Serial Communications

Overview

The 825-P Relay has the following ASCII serial communications interfaces:

- PORT 4 — Slot C for optional Modbus network communications.
- PORT F — Front-panel EIA-232 serial port.

This chapter describes the connections and commands used with ASCII serial communications.

ASCII Serial Port Operation

Introduction

The serial port interface provides an efficient way to communicate with the relay using a PC to review and enter the settings, access metering data, review self-test status, retrieve event summaries, and obtain motor operating statistics reports.

Required Equipment

To connect a PC serial port to the relay front panel serial port and enter relay commands, the following equipment is required:

- A personal computer equipped with one available EIA-232 serial port
- A standard null-modem communication cable to connect the computer serial port to the relay serial port
- Terminal emulation software to control the computer serial port
- The 825-P Relay

On most personal computers, the connector for the EIA-232 serial port is a 9-pin “D” subconnector. You can purchase the cable to connect the computer port to the relay port from most computer hardware retailers, or you can build your own cable using the pinouts shown in Table 53.

You can use a variety of terminal emulation programs on your PC to communicate with the 825-P. Examples of PC-based terminal emulation programs include:

- ProComm Plus®
- Relay/Gold
- Microsoft Windows® HyperTerminal
- SmartCOM
- CROSSTALK®
- Tera Term

Connect Your PC to the Relay

Connect the PC serial port to the 825-P serial port using a standard null-modem communication cable with the pinout shown in Figure 53. For best performance, the cable should not be more than 15 meters (50 feet) long.

Figure 53 - Serial Cable Pinout

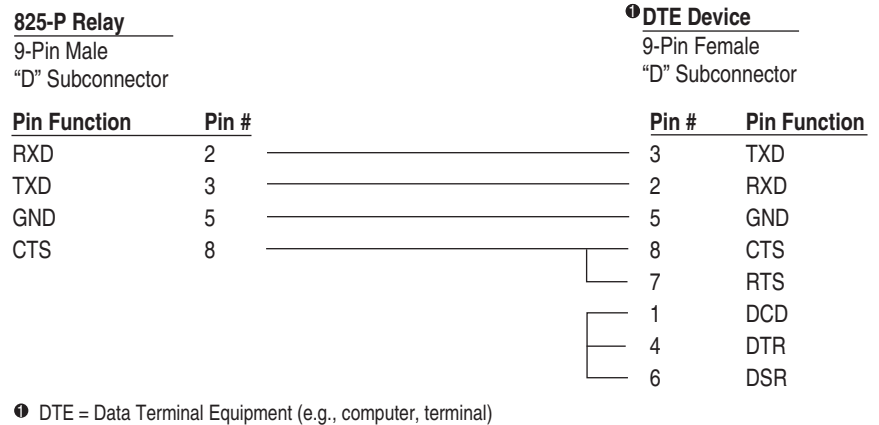

Figure 54 shows the front-panel EIA-232 serial port (PORT F) DB-9 connector pinout for the 825-P. Table 95 shows the pin functions and definitions for the serial port.

Figure 54 - DB-9 Connector Pinout for EIA-232 Serial Ports

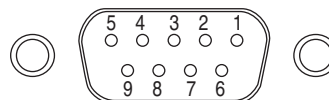

Table 95 - Pin Functions and Definitions for EIA-232 Serial Port (Port F)

Pin	Pin Function	Definition
1, 4, 6	N/C	No connection
2	RXD, RX	Receive data
3	TXD, TX	Transmit data
5, 9	GND	Signal ground
7	RTS	Request to send
8	CTS	Clear to send

Configure Your Terminal Emulation Software

Personal computers use terminal emulation software to send and interpret received characters at the EIA-232 serial port. This software allows you to type letters and numbers to form commands at the computer keyboard and to see the characters you type and the relay responses on the computer screen. To ensure the PC communicates correctly with the relay, configure the terminal emulation software connection properties to match the relay serial port configuration.

Configure the terminal emulation software to match the default settings shown in Table 96. For the best display, use VT-100 terminal emulation. If VT-100 is not available, WYSE-100 and ANSI terminal emulations also work.

Table 96 - 825-P Relay Serial Communications Default Settings

Setting	Default
Speed (bps)	9600
Data Bits	8
Parity	N
Stop Bits	1
Flow Control	XON/XOFF (software flow control)

To change the port settings, use the front-panel SET/SHOW > PORT settings menu item.

Serial Port Settings

The 825-P provides settings that allow you to configure the communication parameters for the front-panel serial port. The front-panel serial port supports only ASCII communications.

Table 97 - Front Panel Serial Port Settings

Setting Prompt	Setting Range	Factory Default
SPEED	300–38400 bps	9600
DATA BITS	7, 8 bits	8
PARITY	0, E, N	N
STOP BITS	1, 2 bits	1
PORT TIMEOUT	0–30 min	15
HDWR HANDSHAKING	Y, N	N

The 825-P front-panel serial port supports EIA-232 communication of ASCII text data. Table 97 shows relay serial port settings for the front-panel port. Set the Baud Rate, Data Bits, Parity, and Stop Bits settings to match the serial port configuration of the equipment that is communicating with the serial port.

After Port Timeout minutes of inactivity on a serial port at Access Level 2, the port automatically returns to Access Level 1. This security feature helps prevent unauthorized access to the relay settings if the relay is accidentally left in Access Level 2. If you do not want the port to time out, set Timeout equal to 0 minutes.

The relay EIA-232 serial ports support software (XON/XOFF) flow control. If you want to enable support for hardware (RTS/CTS) flow control, set the Enable Hardware Handshaking setting equal to Y.

Using Terminal Commands

When you type commands at the terminal emulation window, type either the entire command or just use the first three letters (e.g., the following commands instruct the relay to display metering data):

Type METER (or MET) and press Enter.

Use upper- or lower-case characters when typing commands; however, password entry is case sensitive. Table 99 lists user commands that the relay accepts at the EIA-232 serial port.

The relay serial port uses software flow control, meaning that character transmission is controlled by receipt of XON and XOFF characters. When the relay receives the XOFF character during transmission, it pauses until it receives an XON character. If a message is not in progress when the relay receives the XOFF character, it blocks transmission of a message presented to its buffer. Messages are transmitted after the relay receives the XON character.

You can send control characters from most keyboards using the keystrokes listed in Table 98.

Table 98 - Serial Port Control Characters

Control Characters	Key Commands
XON	Ctrl+Q
XOFF	Ctrl+S
CAN	Ctrl+X

You can use the XOFF character to pause in the middle of long transmissions from the relay. To resume the transmission, use the XON character. To cancel a transmission in progress, use the **Ctrl+X** key commands.

Serial Port Access Levels

Issue commands to the relay via the front serial port, e.g., to view metering values or change the relay settings. Refer to Table 99 available serial port commands. Access these commands only from the corresponding access level, as listed in the table.

Access levels are:

- Access Level 0 (the lowest access level)
- Access Level 1
- Access Level 2 (the highest access level)

Access Level 0

Once serial port communications are established with the relay, the relay displays the = prompt (an equal sign). This is referred to as Access Level 0. The only command available at Access Level 0 is the ACC command (see Table 99). Type ACC at the Access Level 0 prompt and then press Enter. The ACC command takes the relay to Access Level 1.

Access Level 1

The Access Level 1 commands primarily allow you to view information (such as settings and metering) but not to change settings. When the relay is in Access Level 1, the relay sends the prompt: =>. Type 2AC at the prompt and then press Enter to take the relay to Access Level 2.

Access Level 2

The Access Level 2 commands primarily allow you to change relay settings, reset data buffers, and control relay outputs. If left in Access Level 2, the serial port automatically returns to Access Level 1 after a settable inactivity period. All Access Level 1 commands are also available in Access Level 2. When the relay is in

Access Level 2, the relay sends the =>> prompt at which you press **Enter** or after a command response is finished.

Command Summary

Table 99 lists the serial port commands associated with particular activities. The commands are shown in upper-case letters, but they can also be entered with lower-case letters.

Table 99 - 825-P Serial Port Command Summary

Serial Port Command	Access Level	Command Description	Page Number
2ACCESS	1, 2	Go to Access Level 2.	Page 167
ACCESS	0, 2	Go to Access Level 1.	Page 167
ANALOG	2	Test analog output.	Page 167
DATE	1, 2	View or Change date.	Page 167
METER	1, 2	Display metering data.	Page 168
MOTOR	1, 2	Display motor operating statistics report.	Page 170
MOTOR R or C	2	Reset motor operating statistics.	Page 170
PASSWORD	2	View or Change password.	Page 170
QUIT	1, 2	Go to Access Level 0.	Page 171
SER	1, 2	View serialized events recording data.	Page 171
SER R or C	1, 2	Reset serialized events recording data.	Page 171
SET	2	Enter or Change relay settings.	Page 172
SHOW	1, 2	Show/view relay settings.	Page 173
STATUS	1, 2	Display relay self-test status.	Page 174
STATUS R or C	2	Clear self-test status and restart relay.	Page 177
STOP	2	Stop motor.	Page 177
STR	2	Start motor.	Page 177
SUMMARY	1, 2	View event summary reports.	Page 177
SUMMARY R or C	1, 2	Reset event summary buffer.	Page 178
TARGET	1, 2	Display relay elements, inputs or outputs status.	Page 178
TARGET R	2	Reset trip/target LEDs.	Page 179
TIME	1, 2	View or Change time.	Page 179

The serial port command explanations that follow in the Description of Commands subsection are in alphabetical order to correspond with Table 99.

Description of Commands

Each command explanation lists:

- Command.
- Serial port access levels where the command is available, in parentheses.
- Explanation of the command use or response.

For example, issue the **DATE** command from serial port Access Level 1 or 2.

ACC and 2AC (Level 1 or 2)

The **ACC** and **2AC** commands provide entry to the multiple access levels. Different commands are available at the different access levels, as shown in Table 99. Commands **ACC** and **2AC** operate similarly:

- **ACC** command moves the relay from Access Level 0 to Access Level 1 or Access Level 2 to Access Level 1.
- **2AC** command moves the relay from Access Level 1 to Access Level 2.

The relay is shipped from the factory with the Access Level 1 and Access Level 2 passwords disabled. See **PASSWORD (Level 1 or 2)** on page 170 for information on Access Level 1 and Access Level 2 password protection.

The relay sets the **SALARM Relay Word** bit for one second after a successful move to Access Level 2.

ANALOG (Level 2)

Use the **ANALOG p t** command to test the relay analog current output. When you use this command, the relay ends normal analog current output and sends a signal defined by the percentage value, **p** = 0...100% for **t** minutes (**t** = 1...10 minutes). For example, when the analog output signal type is 4...20 mA, the command **ANA 75 5.5** instructs the relay to output 16 mA (75% of full scale) for 5.5 minutes or until a character or space key is pressed to end the test.

You can also use the **ANALOG** command to generate a current signal that increases linearly. Replace the fixed percentage value with an **R** to ramp the signal from zero to full scale over time. For example, the command **ANA R 10** instructs the relay to ramp the analog signal from zero to full scale, reaching full scale in 10 minutes. Stop the test by pressing a keyboard character key or the space bar.

DATE (Level 1 or 2)

DATE displays the date stored by the internal calendar/clock.

If the date format setting **DATE_F** is set to MDY, the date is displayed as month/day/year. If the date format setting is set to YMD, the date is displayed as year/month/day and for DMY it is displayed as day/month/year.

To set the date (and the date format setting is MDY), type `DATE mm/dd/yyyy` and then press Enter.

To set the date for a date format setting of YMD, type `DATE yyyy/mm/dd` and then press Enter.

To set the date for a date format setting of DMY, type `DATE dd/mm/yyyy` and then press Enter.

You can separate the month, day, and year parameters with spaces, commas, slashes, colons, or semicolons.

METER (Level 1 or 2)

The **METER** commands provide access to the relay metering data. The relay divides the displayed information into two groups:

Note: All ASCII command responses in this section are examples only. Your specific relay has differences based on model number, firmware revision number, and application.

- Instantaneous
- Thermal and RTD

METER k (Instantaneous Metering)

The **METER k** command displays instantaneous magnitudes (and angles, if applicable) of the measured and calculated analog quantities.

All angles are displayed between -180 and $+180$ degrees. For delta-connected PTs, angles are referenced to VAB or L1 and for wye-connected PTs, angles are referenced to VAN or L1.

If the voltage channels are not supported, or $VAB < 13V$ (for delta) or $VAN < 13V$ (for wye), angles are referenced to L1 current.

To view the instantaneous meter values once, use the **METER** command (see the example in Figure 55). To view the meter values *k* times, use the **METER k** command, where *k* is a number between 1 and 32767.

Figure 55 - View Instantaneous Meter Values Once - Example

```

=>>MET
825-P Modular                               Date: 03/05/2003   Time: 16:44:08.404
Prot. System

          L1      L2      L3
Current Magnitude (A)      21.2    21.3    21.5
Current Angle (deg)      -42.0   -162.5   78.2
Average Current Magnitude (A)      21.3
Motor Load (x Ie)          0.9
GF Current-Core Balance (A)          0.00
GF Current-Core Balance Angle (deg)  -76.6
GF Current-Residual (A)          0.0
GF Current-Residual Angle (deg)     72.3
Current Imbalance (%)          1.0
          VAN      VBN      VCN      VG
Voltage Magnitude L-N (V)      334      334      334      4
Voltage Angle (deg)          0.0     -119.6    120.8   -116.1
Average Phase (V)            334
Voltage Imbalance (%)          0.0
Real Power (kW)              16
Reactive Power (kVAR)        14
Apparent Power (kVA)         21
Power Factor                  0.74 LAG

Frequency (Hz)               60.0
=>>
    
```

METER T (Thermal and RTD Metering)

The **METER T** command displays the temperatures of any connected RTDs. This command also shows the average motor current ($x I_e$), the present % Thermal Capacity used, and the RTD % Thermal Capacity (if ambient and winding temperatures are monitored and a winding RTD trip temperature is set).

If the motor is in overload, this command response shows the calculated time to a thermal trip. If the motor is not in overload (e.g., see Figure 56), the time shown is 9999 seconds. The Starts Available and Time To Reset values are also displayed.

Figure 56 - Calculated Time to a Thermal Trip - Example

```

=>>>MET T
825-P Modular                               Date: 03/05/2003   Time: 16:13:50.321
Prot. System
Max Winding RTD = 61 C
Max Bearing RTD = 48 C
Ambient RTD = 28 C
Max Other RTD = 50 C
RTD 1 WDG = 61 C
RTD 2 NONE
RTD 3 WDG = 59 C
RTD 4 WDG = 58 C
RTD 5 WDG = Open
RTD 6 WDG = 57 C
RTD 7 BRG = 48 C
RTD 8 BRG = 46 C
RTD 9 BRG = 45 C
RTD 10 BRG = 44 C
RTD 11 AMB = 28 C
RTD 12 OTH = 50 C
Motor Load (x Ie)          0.9
Thermal Capacity Used (%)      32
RTD % Thermal Capacity (%)     27
Calculated Time to Thermal Trip (sec)  9999
Time to Reset (min)          0
=>>
    
```

MOTOR (Level 1 or 2)

The **MOTOR** command displays the motor operating statistics that include the following:

- Motor running time, stopped time, and percent time running.
- Total number of motor starts.
- Number of emergency starts.

[Chapter 7, Metering & Monitoring](#), includes additional details on the motor operating statistics report. Issuing the **MOTOR R** or **MOTOR C** command from Access Level 2 clears the report.

PASSWORD (Level 1 or 2)

NOTE: This device is shipped with Access Level 1 and Access Level 2 password protection disabled. Access Level 1 and Access Level 2 password protection must be restored at installation. Failure to install Access Level 1 and Access Level 2 private passwords could allow unauthorized access. Rockwell Automation is not be responsible for damage resulting from unauthorized access.

The Access Level 2 **PAS** command allows you to inspect or change the existing password. To inspect the Access Level 1 and Access Level 2 passwords, type **PAS** and then press Enter.

The relay displays the present passwords.

The factory ships the relay with the passwords disabled.

For example, to change the password for Access Level 2 to **BIKE**, type **PAS 2 BIKE** and then press Enter.

After entering the new password, type **PAS** and then press Enter to inspect it.

If the password is correct, record it for future reference. If you make three incorrect password guesses, access is denied and the SALARM Relay Word bit is set for one second.

The password can include up to eight characters. Valid characters consist of all printable characters from the 7-bit ASCII set typically found on the PC keyboard. The space character is not included.

Strong passwords consist of eight characters, with at least one special character or digit and mixed-case sensitivity, but do not form a name, date, acronym, or word. Passwords formed in this manner are less susceptible to password guessing and automated attacks.

To disable password protection for Access Level 1 or Access Level 2, set its password to DISABLE.

QUIT (Level 1 or 2)

The **QUI** command returns the relay to Access Level 0 from either Access Level 1 or Access Level 2.

SER (Level 1 or 2)

Use the **SER** command to view the Serialized Events Recording (SER) report, described in detail in Chapter 8: Analyzing Events.

Each event record is stored with a record number, a date, and a time. You can access SER data by record number or by date. The most recent record is always record number 1. The various **SER** command options are shown in Table 100.

Table 100 - SER Command Options

Serial Port Command	Description
SER	Display all SER records.
SER n	Display the <i>n</i> most recent SER records starting with record <i>n</i> .
SER n1 n2	Display SER records <i>n2</i> to <i>n1</i> , starting with <i>n2</i>
SER d1	Display all SER records made on date <i>d1</i>
SER d1 d2	Display all SER records made from dates <i>d2</i> to <i>d1</i> , inclusive, starting with <i>d2</i>

The date entries used with the **SER** command are dependent on the Date Format setting. If the Date Format setting equals MDY, then use the format mm/dd/yyyy for entered dates. If the Date Format setting equals YMD, then use the format yyyy/mm/dd for the entered dates. If the Date Format setting equals DMY, then use the format dd/mm/yyyy for the entered dates.

If the requested SER records do not exist, the relay displays the message No SER Data.

SER R or C (Level 1 and 2)

The **SER R** or **SER C** command removes the SER data from nonvolatile memory.

SET (Level 2)

The **SET** command allows you to view or change the relay settings.

Table 101 - Serial Port SET Commands

Command	Settings Type	Description
SET	Relay	Protection elements, timers, etc.
SET P	Port	Serial port settings for Serial Port F
SET M	Relay	I/O mapping settings

When you issue the **SET** command, the relay presents a list of settings one at a time. Enter a new setting or press Enter to accept the existing setting. Editing keystrokes are shown in Table 102.

Table 102 - SET Command Editing Keystrokes

Do the Following	Results
Press Enter	Retains setting and moves to next setting.
Type ^ and then press Enter	Returns to previous setting.
Type < and then press Enter	Returns to previous setting category.
Type > and then press Enter	Moves to the next setting category.
Type END and then press Enter	Exits editing session, then prompts you to save settings.
Press Ctrl+X	Aborts editing session without saving changes.

The relay checks each entry to ensure that it is within the setting range. If it is not, an Out of Range message is generated, and the relay prompts you for the setting again.

When all the settings are entered, the relay displays the new settings and prompts you for approval to enable them. Type Y and then press Enter to enable the new settings. The relay is disabled for as long as five seconds while it saves the new settings. The SALARM Relay Word bit is set momentarily and the ENABLE LED extinguishes while the relay is disabled.

To change a specific setting, enter the command shown in Table 103.

Table 103 - SET Command Format

SET n s TERSE	
Where:	
n	is left blank to enter relay settings.
n	is P to enter front serial port settings.

Table 103 - SET Command Format

SET n s TERSE	
n	is M to enter I/O mapping settings.
s	is the short parameter name of the specific setting you want to jump to and begin setting. If s is not entered, the relay starts at the first setting (e.g., enter 50PIP to start at Short Circuit Trip level setting).
TERSE	instructs the relay to skip the settings display after the last setting. Use this parameter to speed up the SET command. If you want to review the settings before saving, do not use the TERSE option.

SHOW

Use the **SHOW** command to view relay settings and serial port settings (see Figure 61). The **SHOW** command options are listed in Table 104.

Table 104 - SHOW Command Options

Command	Description
SHOW	Show relay settings.
SHO A	Show all relay settings: enabled, disabled/hidden.
SHO P	Show serial port settings.
SHO M	Show I/O mapping settings.

You can append a setting name to each of the commands to specify the first setting to display (e.g., **SHO 50P1P** displays the relay settings starting with setting 50P1P). The default is the first setting.

The **SHOW** command displays only the enabled settings. To display all the settings, including disabled/hidden settings, append an **A** to the **SHOW** command (e.g., **SHOW A**).

Figure 57 - SHOW Command Example

```

=>SHO
RID      :=825-P Modular
TID      :=Prot. System
PHROT    := ABC      FNOM    := 60      DATE_F   := MDY    CTR1     := 5
FLA1     := 25.0    E2SPEED := N      CTRN     := 100    PTR      := 5.00
VNUM     := 600     DELTA_Y  := WYE
E49MOTOR:= Y      49RSTMD := AUTO    49RSTP   := 75    SF       := 1.00
LRA1     := 12.0    LRTHOT1 := 10.0    TD1      := 1.00    RTC1     := AUTO
TCAPU    := 85     TCSTART  := OFF    COOLTIME:= 44    ETHMBIAS:= Y
50P1P    := OFF    50P2P   := OFF    50N1P    := OFF    50N2P    := OFF
50G1P    := OFF    50G2P   := OFF
LJTPU    := OFF    LJAPU    := OFF
LLTPU    := OFF    LLAPU    := OFF
46UBT    := OFF    46UBA    := 10    46UBAD   := 10    PROTBL_T:= OFF
THERBL_T:= OFF
START_T  := OFF
ESTAR_D  := N
MAXSTART:= OFF    TBSDLY   := OFF
ABSDLY   := OFF
E47T     := N
SPDSDLYT:= OFF    SPDSDLYA:= OFF
EPTC     := N
E49RTD   := Y      RTDRST   := AUTO    RTD1LOC  := WDG    RTD1TY   := PT100
TRTMP1   := 150    ALTMP1   := 120    RTD2LOC  := OFF    RTD3LOC  := WDG
RTD3TY   := PT100 TRTMP3   := OFF    ALTMP3   := OFF    RTD4LOC  := WDG
RTD4TY   := PT100 TRTMP4   := OFF    ALTMP4   := OFF    RTD5LOC  := WDG
RTD5TY   := PT100 TRTMP5   := OFF    ALTMP5   := OFF    RTD6LOC  := WDG
RTD6TY   := PT100 TRTMP6   := OFF    ALTMP6   := OFF    RTD7LOC  := BRG
RTD7TY   := PT100 TRTMP7   := OFF    ALTMP7   := OFF    RTD8LOC  := BRG
RTD8TY   := PT100 TRTMP8   := OFF    ALTMP8   := OFF    RTD9LOC  := BRG
RTD9TY   := PT100 TRTMP9   := OFF    ALTMP9   := OFF    RTD10LOC:= BRG
RTD10TY  := PT100 TRTMP10  := OFF    ALTMP10  := OFF    RTD11LOC:= AMB
RTD11TY  := PT100 TRTMP11  := OFF    ALTMP11  := OFF    RTD12LOC:= OTH
RTD12TY  := PT100 TRTMP12  := OFF    ALTMP12  := OFF    EWDGV    := N
EBRGV    := N      ERTDBIAS:= N
27P1P    := OFF    27P2P   := OFF
59P1P    := OFF    59P2P   := OFF
NVARTP   := OFF    PVARTP   := OFF    NVARAP   := OFF    PVARAP   := OFF
37PTP    := OFF    37PAP   := OFF
55LGTP   := 0.50   55LDTP   := OFF    55TD     := 1      55LGAP   := 0.50
55LDAP   := OFF    55AD     := 1
81D1TP   := OFF    81D1AP  := OFF
81D2TP   := OFF
81D2AP   := OFF
LOAD     := OFF
AOPARM   := LOAD_I
BLK46    := N      BLK48    := N      BLK50EF  := N      BLK50P   := N
BLK37    := N      BLK66    := N      BLK49PTC:= N      BLK49RTD:= N
TRIPFS   := Y      AUX1FS   := Y      AUX2FS   := Y      AUX3FS   := Y
AUX4FS   := Y      AUX5FS   := Y      AUX6FS   := Y
T1ONDLY  := 0      T1OFFDLY:= 0      T2ONDLY  := 0      T2OFFDLY:= 0
FP_TO    := 15     FP_CONT  := 5
FP_TD    := N      FP_GC    := N      FP_LA    := N      FP_MF    := N
FP_TH    := N      FP_VA    := N      FP_PE    := N      FP_RTD   := N
=>

```

STATUS (Level 1 or 2)

The **STATUS** command displays the relay hardware and software self-test diagnostics and resolves hardware configuration conflicts when detected (see Figure 58).

To view a status report, enter the **STATUS** command. To view the status report *k* times, enter the command **STATUS k**, where *k* is a number between 1 and 32767. [Table 105](#) shows the status report definitions and message formats for each test.

Table 105 - STATUS Command Report and Definitions

STATUS Report Designator	Definition	Message Format
FID	Firmware identifier string	(FID string)
CID	Firmware checksum identifier	xxxx
Identity Code	Relay configuration identification	Identity string
Current Offset (L1, L2, L3, RES, CB)	DC offset in hardware circuits of current channels	OK/WARN
Voltage Offset (VA, VB, VC)	DC offset in hardware circuits of voltage channels	OK/WARN
PS_Vdc	Power supply status	OK/FAIL
FPGA	FPGA programming unsuccessful, or FPGA failed	OK/FAIL
GPSB	General Purpose Serial Bus	OK/FAIL
HMI	front panel FGPA programming unsuccessful, or front panel FPGA failed	OK/WARN
RAM	Volatile memory integrity	OK/FAIL
ROM	Firmware integrity	OK/FAIL
CR_RAM	Integrity of settings in RAM and code that runs in RAM	OK/FAIL
Non_Vol	Integrity of data stored in nonvolatile memory	OK/FAIL
Clk_Bat	Clock battery integrity	OK/WARN
Clock	Clock functionality	OK/WARN
PTC	Integrity of PTC	OK/FAIL
RTD	Integrity of RTD module/communications	OK/FAIL
MCM/CWE	Integrity of current board and MCM/CWE	OK/FAIL
Voltage	Integrity of voltage board	OK/FAIL
I/O_Crd	Integrity of I/O card	OK/FAIL
COM_Crd	Integrity of DeviceNet card and network	OK/FAIL
MAC ID	DeviceNet card specific card identification.	xxxxxx
ASA	Manufacturer identifier for DeviceNet.	xxxx xxxxx
DN_Rate	DeviceNet card network communications data speed	___ kbps
DN_Status	DeviceNet connection and fault status.	000b bbbb

Figure 58 - STATUS Command - Example

```

=>>STA
825-P Modular                               Date: 03/03/2003   Time: 11:54:40.361
Prot. System

FID=825-P-R100-V0-Z001001-D20030225      CID=010C

Identity Code 1522001BCX0X1X1X

SELF TESTS

Current  L1      L2      L3      RES      CB
Offset:  OK      OK      OK      OK      OK

Voltage  VA      VB      VC
Offset:  OK      OK      OK

PS_Vdc   FPGA    GPSB    HMI
OK       OK     Ok     Ok

RAM      ROM      CR_RAM  Non_Vol  Clk_Bat  Clock
OK       OK      OK      OK      Ok      OK

PTC      RTD      MCM/CWE  Voltage  I/O_Crd  Com_Crd
OK       Ok     OK      OK      OK      OK

MAC_ID   ASA      DN_Rate  DN_Status
0        0000 0000h   0kbps   0000 0000

Relay Enabled

=>>
    
```

Figure 59 - Identity Code Explanation

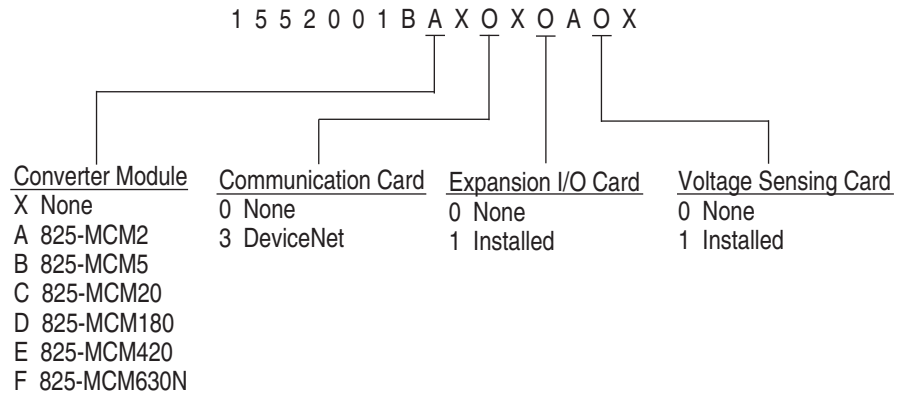
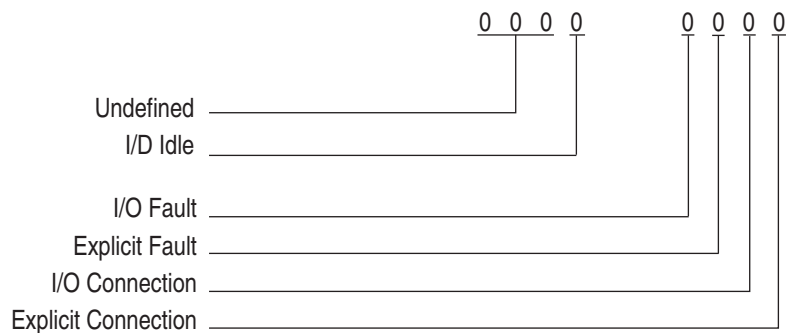

Figure 60 - DN_Status Explanation



STATUS R or C (Level 2)

To reset the self-test status and restart the relay, enter the **STA R** command from Access Level 2.

The relay then restarts (like powering down and then powering up the relay) and all diagnostics are rerun before the relay is enabled.

STOP (Level 2)

The **STOP** command causes the relay to trip, opening the motor contactor or circuit breaker and stopping the motor. For more details refer to [Chapter 6: Configuring Protection & Logic Functions](#).

STR (Level 2)

The **STR (START)** command initiates a motor start using the relay's internal logic. For more details refer to [Chapter 6: Configuring Protection & Logic Functions](#).

SUMMARY (Level 1 or 2)

The **SUM *n*** command displays a summary list, in reverse chronological order, of all the archived event summary reports (maximum of five events).

An example event summary report is in Figure 61. Each event summary report shows the date, time, current magnitudes (primary values) and, if the relay has the voltage option, voltage magnitudes (primary values). The current and voltage values are at the trigger instant. The event summary report also shows the event type (e.g., OVERLOAD TRIP).

The *n* parameter with the **SUM *n*** command can have a value up to 5 and defines the number of events requested. If *n* is not specified, then up to five of the most recent reports are listed.

For more information on events, refer to [Chapter 8, Analyzing Events](#).

Figure 61 - SUMMARY Command - Example

```

=>>SUM 2
825-P Modular                               Date: 02/04/2003   Time: 17:20:46.439
Prot. System
Event #: 1                                   Event: OVERLOAD TRIP
Event Date: 01/29/2003                      Event Time: 14:14:01.930
CURRENT MAG (A)                             L1      L2      L3      RES      CB
8.2      8.1      8.2      0.0      0.00
Event #: 2                                   Event: OVERLOAD TRIP
Event Date: 01/29/2003                      Event Time: 14:13:05.931
CURRENT MAG (A)                             L1      L2      L3      RES      CB
8.2      8.2      8.2      0.0      0.00
=>>
    
```

SUMMARY R (Level 1 and 2)

The **SUMMARY R** command clears all the events in the event buffer.

TARGET (Level 1 or 2)

The **TARGET** command displays the status of relay elements whether they are asserted or de-asserted. The elements are represented as Relay Status bits and are listed in rows of eight, called Relay Status rows. For additional information on individual Relay Status bits, refer to [Appendix C, Relay Word Bits](#).

A Relay Word bit is either at logical 1 (asserted) or at logical 0 (de-asserted).

The **TAR** command options are listed in Table 106.

Table 106 - TARGET Command Options

Commands	Descriptions
TAR n k	Shows Relay Word Row n (0–10). k is an optional parameter to specify the number of times (1–32767) to repeat the Relay Word row display. If k is not specified, the Relay Word row is displayed once. See Table 106 for the definition of Row 0. See Table for a list of the Relay Word bits in each row (n = 1–10).
TAR name k	Shows the Relay Word bit row containing the Relay Word bit name (e.g., TAR 50P1T displays Relay Word Row 1). Valid names are shown in TARGET R (Level 2) on page 179. k is an optional parameter to specify the number of times (1–32767) to repeat the Relay Word bit row display. If k is not specified, the Relay Word row is displayed once.

Table 107 - Front-Panel LEDs and the TAR 0 Command

LED Number/State	7	6	5	4	3	2	1	0
ALARM (Flashing)	N/A	WARNING	N/A	N/A	N/A	N/A	N/A	N/A
ON Steady (Latched)	ENABLE	TRIP	N/A	N/A	N/A	N/A	N/A	N/A

TARGET R (Level 2)

The **TARGET R** command resets the front-panel tripping targets and releases the trip signal if the fault condition has vanished and lockout conditions are not present. If you issue the **TARGET R** command at the relay serial port or use the front-panel Test/Reset push button and the relay tripping targets do not reset, verify that the fault condition and all lockouts have cleared.

TIME (Level 1 or 2)

The **TIME** command displays the relay clock (24 hours). To set the clock, type `TIME hh:mm:ss` and then press Enter.

Separate the hours, minutes, and seconds with colons, semicolons, spaces, commas, or slashes. For example, set 22:47:36 by typing `TIME 22:47:36` and then pressing Enter:

View or Change Settings with Front Panel Serial Port View Settings

Use the **SHOW** command to view relay settings. The **SHOW** command is available from Access Level 1 and Access Level 2.

Table 108 lists the **SHOW** command options.

Table 108 - SHOW Command Options

Command	Description
SHOW	Show relay settings.
SHO A	Show all relay settings: enabled, disabled/hidden.
SHO P	Show front serial port settings.
SHO M	Show I/O mapping settings.

You can append a setting name to each of the commands to specify the first setting to display (e.g., **SHO 50P1P** displays the relay settings starting with setting 50P1P). The default is the first setting.

The **SHOW** command displays only the enabled settings. To display all the settings, including disabled/hidden settings, append an **A** to the **SHOW** command (e.g., **SHOW A**).

Enter Settings

The **SET** command (available from Access Level 2) allows you to view or change the settings. Table 109 lists the **SET** command options.

Table 109 - SET Command Options

Command	Settings Type	Description
SET	Relay	Protection elements, timers, etc.
SET P	Port	Settings for front panel Serial Port F.
SET M	Relay	Input/output mapping settings.

When you issue the **SET** command, the relay presents a list of settings one at a time. Enter a new setting or press <Enter> to accept the existing setting. Editing keystrokes are listed in Table 110.

Table 110 - SET Command Editing Keystrokes

Keystroke	Results
Press Enter	Retains setting and moves to next setting.
Type ^ and press Enter	Returns to previous setting.
Type < and press Enter	Returns to previous setting category.
Type > and press Enter	Moves to next setting category.
Type END and press Enter	Exits editing session, then prompts you to save settings.
Press Ctrl+ X	Aborts editing session without saving changes.

The relay checks each entry to ensure that the entry is within the setting range. If it is not in range, an **Out of Range** message is generated, and the relay prompts you for the setting again.

When all the settings are entered, the relay displays the new settings and prompts you for approval to enable them. Type **Y** and then press Enter to enable the new settings. The relay is disabled for as long as 5 seconds while it saves the new settings. The **ALARM Relay Word** bit is set momentarily and the **Enable LED** extinguishes while the relay is disabled.

The relay also runs interdependency checks between some parameters. If it detects a configuration error between parameters a message is displayed and the user is prompted to change settings to eliminate error before settings can be saved.

To change a specific setting, enter the command shown in Table 111.

Table 111 - SET Command Format

SET n s TERSE	
Where:	
n	is left blank to enter RELAY settings.
n	is P to enter front panel serial port settings.
n	is M to enter I/O mapping settings.
s	is the name of the specific setting you want to jump to and begin setting. If s is not entered, the relay starts at the first setting (e.g., enter 50P1P to start at Short Circuit Trip level setting).
TERSE	instructs the relay to skip the settings display after the last setting. Use this parameter to speed up the SET command. If you want to review the settings before saving, do not use the TERSE option.

Firmware Upgrade Instructions

Overview

Rockwell Automation occasionally offers firmware upgrades to enhance the performance of your relay. Since the 825-P relay stores firmware in flash memory, changing physical components is not necessary. Upgrade the relay firmware by downloading a file from a personal computer to the relay via the front panel serial port as outlined in the following sections.

Required Equipment

Gather the following equipment before starting this firmware upgrade:

- Personal computer (PC)
- Terminal emulation software that supports XMODEM/CRC protocol (e.g., Microsoft® Windows® HyperTerminal)
- Serial communication cable (null-modem cable)
- Disk containing the firmware upgrade (*.S19) file

Upgrade Instructions

The instructions below assume you have a working knowledge of your personal computer terminal emulation software. In particular, you must be able to modify your serial communications parameters (baud rate, data bits, parity, etc.), select transfer protocol (XMODEM/CRC), and transfer files (e.g., send and receive binary files).

1. If the relay is in service, open its motor control circuits.
2. Connect the PC to the front-panel serial port and enter Access Level 2.
3. Save the current relay settings.
 - a. Issue the following commands at the ASCII prompt:
SHO, SHO P, and SHO M.
 - b. Issue the *L_D* command to the relay.
 - c. Type *Y* and press the Enter key at the following prompt:
Disable relay to send or receive firmware (Y/N)?
 - d. Type *Y* and press the Enter key at the following prompt:
Are you sure (Y/N)?

The relay sends the BOOTLDR !> prompt.

4. Type BAU 38400 and press the Enter key.

This changes the baud rate of the communications port to 38400. Change the baud rate of the PC to 38400 to match the relay.

5. Begin the transfer of new firmware to the relay by issuing the **REC** command.
6. Type **Y** to erase the existing firmware or press the Enter key to abort.
7. Press any key (e.g., the Enter key) when the relay sends a prompt.
8. Start the file transfer.
 - a. Select the send file option in your communications software.

Use the XMODEM protocol and send the file that contains the new firmware (e.g., R101xxxx.S19).

The file transfer takes less than 10 minutes at 38400 baud. After the transfer is complete, the relay reboots and returns to Access Level 1.

Figure 62 shows the screen display for the process outlined previously in **Upgrade Instructions**.

Figure 62 - Firmware File Transfer Process

```
=>>L_D <Enter>
Disable relay to send or receive firmware (Y/N)? Y <Enter>
Are you sure (Y/N)? Y <Enter>
Relay Disabled
!>BAU 38400 <Enter>
!>REC <Enter>
Caution! - This command erases the relay's firmware.
If you erase the firmware, new firmware must be loaded into the relay
before it can be put back into service.
Are you sure you wish to erase the existing firmware? (Y/N) Y
Erasing
Erase successful
Press any key to begin transfer, then start transfer at the PC <Enter>
Upload completed successfully. Attempting a restart
```

9. The relay illuminates the ENABLE front-panel LED if the relay settings were retained through the download.

If ENABLE LED is illuminated, proceed to Step 10.

If ENABLE LED is not illuminated or the front-panel displays **STATUS FAIL EEPROM FAILURE**, reload the relay settings with the following steps:

- a. Set the communications software settings to 9600 baud, 8 data bits, and 1 stop bit.
- b. Enter Access Level 2 by issuing the **2AC** command.
- c. Issue the **R_S** command to restore the factory default settings.

The relay then reboots with the factory default settings. If the following message appears during the restart, please contact your local Allen-Bradley distributor.

Calibration settings lost, please call the factory!

- d. Enter Access Level 2.
 - e. Issue **STATUS** command, and verify that the relay status is OK.
 - f. Set the relay clock and calendar using the **DATE** and **TIME** commands.
 - g. Set the Relay and Port settings using the following commands: **SET**, **SET M**, and **SET P**.
 - h. Set the relay passwords with the **PAS** command.
10. Set the communications software settings (baud rate, number of data bits, number of stop bits) to agree with the port settings of the 825-P.
 11. Issue the **STATUS** command, and then verify that all relay self-test results are OK.
 12. Apply current and voltage signals to the relay.
 13. Issue the **METER** command, and then verify that the current and voltage signals are correct.

The relay is now ready for your commissioning procedure.

Specifications

Electrical Ratings

Main Circuits

825 Converter Module						
	MCM2	MCM5	MCM20	MCM180	MCM420	MCM630N
825-MCM Converter Modules						
Rated Operating Voltage U_e — IEC: 400 V AC CSA/UL: 240V AC			690V AC 600V AC		1,000V AC 600V AC	
Rated Impulse Strength U_{imp}	2.5 kV		6 kV		8 kV	
Operating Current Range (A)	0.5-2.5	1-5	2.5-20	20-180	160-420	160-630
Rated Continuous Thermal Current (A)	3	6	24	216	504	756
Rated Saturation Current	30	60	240	1350	3400	4600
Rated Frequency	50/60 Hz \pm 3 Hz					
Voltage Input Option Card						
Rated Operating Voltage U_e	67...300V AC (line-to-line)					
Operating Range	0.80...1.1 U_e					
Rated Continuous Voltage	300V AC					
Rated Insulation Voltage U_i	300V AC					
Rated Impulse Strength U_{imp}	4 kV					
Rated Frequency	50/60 Hz \pm 5 Hz					
Transition Voltage	5...15V			20...79V		
PTC Thermistor Input						
Type of Control Unit	Mark A					
Max. No. of Sensors in Series	6					
Max. Cold Resistance of PTC Sensor Chain	1500 Ω					
Trip Resistance	3400 $\Omega \pm$ 150 Ω					
Reset Resistance	1500 Ω ...1650 Ω					
Short Circuit Trip Resistance	25 $\Omega \pm$ 10 Ω					

Control Circuits

Supply		
Rated Supply Voltage U_s	110...240V AC, 110...250V DC	24...48V DC
Operating Range	0.80...1.1 U_s	0.80...1.1 U_s
Rated Frequency (V AC)	50/60 Hz \pm 5 Hz	
Max. Power Consumption	AC: 15VA, DC: 15 W	
Output Relays		
Type of Contacts	Trip Aux1...Aux 6	Form C DPDT Form A SPDT – NO
Rated Insulation Voltage U_i	300V AC	
Rated Operating Voltage U_e	240V AC	
Rated Impulse Strength U_{imp}	4kV	
Rated Thermal Current I_{the}	5 A	
Rated Operating Current I_e	120V AC 240V AC	3 A 1.5 A
Contact Rating Designation	B300	
Utilization Category	AC15	
Contact Reliability	5 mA @ 17V	
Mechanical Durability	10000 no load operations	
Pickup Time	< 10 ms	
Dropout Time	< 8 ms (typical))	
DC Current Ratings ❶		
	24V DC	0.75 A
	48V DC	0.50 A
	125V DC	0.30 A
	250V DC	0.20 A
Inputs		
Rated Operating Voltage U_e	IN1 and IN2	IN3, IN4 and IN5
	24V AC/DC	120V AC/DC (825-PIOD) 24V AC/DC (825-PIOR)
Operating Range	0.80...1.1 U_e	
Rated Insulation Voltage U_i	300V AC	
Rated Impulse Strength U_{imp}	4kV	
Rated Frequency (AC)	50/60 Hz \pm 5 Hz	
On-State Voltage	15V	79V
On-State Current (turn-on)	2 mA	2 mA
Steady State Current	15 mA	15 mA
Off-State Voltage	5V	20V
Off-State Current	0.5 mA	1 mA

❶ Capacity at L/R = 40 ms

Mechanical Ratings

Environmental	
Ambient Temperature	Storage: -40...+85°C (-40...+185°F) Operating (open): -20...+60°C (-4...+140°F)
Humidity (Operating)	5...95% Non-condensing
Maximum Altitude	2000 m
Vibration (per IEC 68-2-6)	3 G
Shock (per IEC 68-2-27)	30 G
Control Terminals	
Terminal Screw	M3
Cross Section (1 wire, stranded/solid)	0.14...2.5 mm ² /#20...12 AWG
Torque	0.79 N·m/7lb-in
Degree of Protection	IP20
Ground Screw	
Terminal Screw	#6
Torque	1.4 N·m/12 Lb-in

RTD Scanner Module

Supply	
Rated Supply Voltage U_s	110/240V AC
Operating Range	0.80...1.2 U_s
Rated Frequency	50/60 Hz ± 5 Hz
Max. Power Consumption	5 VA
Rated Insulation Voltage U_i	300V AC
Rated Impulse Strength U_{imp}	4kV
Pollution Degree	2
Environmental	
Ambient Temperature Storage	Storage: -40...+85°C (-40...+185°F) Operating: -20...+60°C (-4...+140°F)
Humidity (Operating)	5...95% Non-condensing
Maximum Altitude	2000 m
Vibration (per IEC 68-2-6)	3G
Shock (per IEC 68-2-27)	30G
Inputs	
Number of input channels	12
Type	3-wire
Compatibility	CU10, NI100, NI120, PT100 (per IEC 60751: 1983)
Range	-50...250°C
Accuracy	± 2°C
Open Circuit Detection	> 250°C
Short Circuit Detection	< -50°C
Control Terminals	
Terminal Screw	M3
Cross Section (1 wire, stranded/solid)	0.25...2.5mm ² (24...12 AWG)
Torque	0.4...0.6 Nm (3.5...5.3 Lb-in)
Degree of Protection	1P20

Electromagnetic Compatibility

	Test Level	Performance Criteria
Electrostatic Discharge Immunity	8kV Air Discharge 6kV Contact Discharge	①②
RF Immunity	10V/m	①②
Electrical Fast Transient/Burst Immunity	4kV (Power) 2kV (Control and Comms)	①②
Surge Immunity	2kV L-E 1kV L-L	①②
Emissions		
Radiated	Class A	
Conducted	Class A	

① Performance Criteria 1 requires the DUT to experience no degradation or loss of performance.

② Environment 2.

Metering Accuracy

Phase Currents	+2%
Average Current	+2%
Average Motor Load	+2%
Current Imbalance	+2%
Ground Fault Current (Residual)	+2%
Ground Fault Current (Core Balance)	+2%
Frequency	+0.1 Hz
Line-to-Line Voltages	+2%
Average Line-to-Line Voltage	+2%
Line-to-Neutral Voltages	+2%
Average Line-to-Neutral Voltages	+2%
Voltage Imbalance	+2%
Real 3-Phase Power (kW)	+5%
Reactive 3-Phase Power (kVAR)	+5%
Apparent 3-Phase Power (kVA)	+2%
Power Factor	+2%
RTD Temperatures	+2° C

Standards

CSA 22.2 No. 14, EN60947-5-1, UL 508

Processing

AC Current and Voltage Inputs:	16 samples per power system cycle
Digital Filtering:	One cycle full cosine after low-pass analog filtering. Net filtering (analog plus digital) rejects DC and all harmonics greater than the fundamental.
Protection and Control:	4 times per power system cycle

Primary Current Transformers

Minimum Nominal Operating Voltage	Nominal Operating Voltage of Motor		
Minimum Rated Primary Current I_{1n}	Nominal Operating Current of Motor		
Rated Secondary Current [A]	825-MCM2	825-MCM5	825-MCM20
	1	25	5
Class and Nominal Overcurrent Protection	5P10 ext. 120% ❶		
Power Rating	According to power consumption in leads and measuring circuit.		
Rated Frequency	50/60 Hz		
Burden	825-MCM2	825-MCM5	825-MCM20
Power Consumption at Maximum Rated Current [VA/phase]	0.1	0.2	0.4
Continuous Thermal Current [A]	3	6	24
Thermal Current, 1 s Duration [A]	250	400	600
No Load	An open-circuit secondary is permitted, as the burden is provided in the converter module circuitry.		

❶ Designation according to IEC 60044 part 2:

5	Total Measurement Error (percentage):	± 5% within range up to rated nominal overcurrent ± 1% at rated nominal primary current
P	For Protection Purposes	
10	Rated Nominal Overcurrent Factor:	10X rated nominal primary current
ext. 120%	Extended Rated Thermal Current:	120% of rated nominal primary current (if I_e motor > 87% of rated nominal transformer current)

825-CBCT Core Balance Current Transformer

Ratio	100:1
Current Range	0.5...10 A
Continuous Thermal Current	0.5 A
Saturation Current	30 A
Thermal Current, 1 s Duration	25 A
Rated Burden at Maximum Rated Current	0.4 V A
Rated Frequency	50/60 Hz

DeviceNet Communication Card

Electrical (DeviceNet)	
Supply Voltage	11...25 V DC
Input Current	0.085 A max. / 0.035 A typical
Power Consumption	2.04 W max. / 0.84 W typical
Environmental	
Ambient Temperature	
Operating	-20...+60°C
Storage	-40...+85°C (-40...185°F)
Humidity (operating)	5...95% non-condensing
Vibration (per IEC 68-2-6)	5G
Shock (per IEC 68-2-27)	30G
Communication	
Baud Rates	125, 250, 500 kbps
Distance (max)	
@ 125 kbps	500 m (1640 ft)
@ 250 kbps	200 m (656 ft)
@ 500 kbps	100 m (328 ft)
Standards	
CSA 22.2 No. 14, EN 60947-4-1, EN 60947-5-1, UL 508	

Parameter List

Overview

This appendix lists all accessible parameters of the 825-P relay in numerical order.

The setting range for each parameter is provided to assist especially for applications where it is desirable to set values from a logic controller via a network connection.

Information values provided include the following:

Value	Function
Setting Range	Indicated as raw numerical values.
Scale Factor	Indicate the decimal precision associated with each parameter. This must be given close attention when writing or reading values.
Default	Indicate the factory pre-programmed values.

Group	DeviceNet Param No.	Modbus Register		Parameter Name	Min	Max	Default	Scale Factor	Units	Access
		Read (0x03h)	Write (0x06h)							
Status	1			HDW INPUTS	0 = IN1 1 = IN2 2 = IN3 3 = IN4 4 = IN5 5 = IN6 6 = IN7 7 = IN8		0 0 0 0 0 0 0 0	—	—	Get
	2			HDW OUTPUTS	0 = AUX1 1 = AUX2 2 = AUX3 3 = AUX4 4 = AUX5 5 = AUX6		0 0 0 0 0 0	—	—	Get

Group	DeviceNet Param No.	Modbus Register		Parameter Name	Min	Max	Default	Scale Factor	Units	Access
		Read (0x03h)	Write (0x06h)							
Status (cont.)	3			TRIP STATUS 1	0 = Overload 1 = Undercurrent 2 = Jam 3 = Curr.Imbalance 4 = Short Circuit 5 = RTD - Wind/Bear 6 = PTC 7 = GF - Residual 8 = VAR 9 = Underpower 10 = Undervoltage 11 = Overvoltage 12 = Phase Reversal 13 = Power Factor 14 = Speed Switch 15 = GF - Core Bal.		0 0 0 0 0 0 0 0 0 0 0 0 0 0 0	—	—	Get
	4			TRIP STATUS 2	0 = Start Time 1 = Frequency 1 2 = Frequency 2 3 = RTD - Other 4 = RTD - Ambient 5 = PTC Error 6 = RTD Error 7 = MCM Error 8 = Comm Idle 9 = Comm Loss 10 = Remote Trip 11 = Comm Fault 12 = Alarm - Critical		0 0 0 0 0 0 0 0 0 0 0 0 0	—	—	Get

Group	DeviceNet Param No.	Modbus Register		Parameter Name	Min	Max	Default	Scale Factor	Units	Access
		Read (0x03h)	Write (0x06h)							
Status (cont.)	5			WARN STATUS 1	0 = Overload 1 = Undercurrent 2 = Jam 3 = Curr.Imbalance 4 = Short Circuit 5 = RTD - Wind/Bear 6 = PTC 7 = GF - Residual 8 = VAR 9 = Underpower 10 = Undervoltage 11 = Overvoltage 12 = Reserved 13 = Power Factor 14 = Speed Switch 15 = GF - Core Bal.		0 0 0 0 0 0 0 0 0 0 0 0 0 0 0	—	—	Get
	6			WARN STATUS 2	0 = Reserved 1 = Frequency 1 2 = Frequency 2 3 = RTD - Other 4 = RTD - Ambient 5 = PTC Error 6 = RTD Error 7 = MCM Error 8 = Comm Idle 9 = Comm Loss 10 = Reserved 11 = Comm Fault 12 = Alarm - Critical		0 0 0 0 0 0 0 0 0 0 0 0	—	—	Get

Group	DeviceNet Param No.	Modbus Register		Parameter Name	Min	Max	Default	Scale Factor	Units	Access
		Read (0x03h)	Write (0x06h)							
DeviceNet (cont)	21 (cont.)			STATUS COS MASK 1 (cont.)	11 = AUX4 Status		0	—	—	Get/Set
					12 = AUX5 Status		0			
					13 = AUX6 Status		0			
					14 = Running		0			
					15 = Stopped		0			
	22			STATUS COS MASK 2	0 = Reserved		0	—	—	Get/Set
					1 = Reserved		0			
					2 = IN6 Status		0			
					3 = IN7 Status		0			
					4 = IN8 Status		0			
					5 = IN4 Status		0			
					6 = IN5 Status		0			
					7 = Reserved		0			
					8 = AUX7 Status		0			
					9 = AUX8 Status		0			
					10 = AUX9 Status		0			
					11 = AUX10 Status		0			
	23			FAULT1 COS MASK	0 = Overload		0	—	—	Get/Set
					1 = Undercurrent		0			
					2 = Jam		0			
					3 = Curr.Imbalance		0			
					4 = Short Circuit		0			
					5 = RTD - Wind/Bear		0			
					6 = PTC		0			
					7 = GF - Residual		0			
					8 = VAR		0			
					9 = Underpower		0			
					10 = Undervoltage		0			
					11 = Overvoltage		0			
					12 = Phase Reversal		0			
					13 = Power Factor		0			
					14 = Speed Switch		0			
					15 = GF - Core Bal		0			
	24			FAULT2 COS MASK	0 = Start Time		0	—	—	Get
					1 = Frequency 1		0			
					2 = Frequency 2		0			
					3 = RTD - Other		0			
					4 = RTD - Ambient		0			

Group	DeviceNet Param No.	Modbus Register		Parameter Name	Min	Max	Default	Scale Factor	Units	Access
		Read (0x03h)	Write (0x06h)							
DeviceNet (cont)	24 (cont.)			FAULT2 COS MASK (cont.)	5 = PTC Error		0	—	—	Get
					6 = RTD Error		0			
					7 = MCM Error		0			
					8 = Comm Idle		0			
					9 = Comm Loss		0			
					10 = Remote Trip		0			
					11 = Comm Fault		0			
					12 = Alarm - Critical		0			
	25			WARN1 COS MASK	0 = Overload		0	—	—	Get/Set
					1 = Undercurrent		0			
					2 = Jam		0			
					3 = Curr.Imbalance		0			
					4 = Short Circuit		0			
					5 = RTD - Wind/Bear		0			
					6 = PTC		0			
					7 = GF - Residual		0			
					8 = VAR		0			
					9 = Underpower		0			
					10 = Undervoltage		0			
					11 = Overvoltage		0			
					12 = Phase Reversal		0			
					13 = Power Factor		0			
					14 = Speed Switch		0			
					15 = GF - Core Bal.		0			
	26			WARN2 COS MASK	0 = Start Time		0	—	—	Get
					1 = Frequency 1		0			
					2 = Frequency 2		0			
					3 = RTD - Other		0			
					4 = RTD - Ambient		0			
					5 = PTC Error		0			
					6 = RTD Error		0			
					7 = MCM Error		0			
					8 = Comm Idle		0			
					9 = Comm Loss		0			
					10 = Remote Trip		0			
					11 = Comm Fault		0			
					12 = Alarm - Critical		0			
	27			DEVICENET VOLTAGE	0	6500	—	100	V	Get

Group	DeviceNet Param No.	Modbus Register		Parameter Name	Min	Max	Default	Scale Factor	Units	Access
		Read (0x03h)	Write (0x06h)							
Aux Outputs	28			GRPA PR FLTSTATE	0 = Go to FltValue (#29) 1 = Ignore Trip		0	—	—	Get/Set
	29			GRPA PR FLTVALUE	0 = Open 1 = Closed		0	—	—	Get/Set
	30			GRPA DN FLTSTATE	0 = Go to FltValue (#31) 1 = Ignore Trip		0	—	—	Get/Set
	31			GRPA DN FLTVALUE	0 = Open 1 = Closed		0	—	—	Get/Set
	32			GRPA DN IDLSTATE	0 = Go to FltValue (#33) 1 = Ignore Trip		0	—	—	Get/Set
	33			GRPA DN IDLVALUE	0 = Open 1 = Closed		0	—	—	Get/Set
	34			GRPB PR FLTSTATE	0 = Go to FltValue (#35) 1 = Ignore Trip		0	—	—	Get/Set
	35			GRPB PR FLTVALUE	0 = Open 1 = Closed		0	—	—	Get/Set
	36			GRPB DN FLTSTATE	0 = Go to FltValue (#37) 1 = Ignore Trip		0	—	—	Get/Set
	37			GRPB DN FLTVALUE	0 = Open 1 = Closed		0	—	—	Get/Set
	38			GRPB DN IDLSTATE	0 = Go to FltValue (#39) 1 = Ignore Trip		0	—	—	Get/Set
	39			GRPB DN IDLVALUE	0 = Open 1 = Closed		0	—	—	Get/Set
	40			GRPC PR FLTSTATE	0 = Go to FltValue (#41) 1 = Ignore Trip		0	—	—	Get/Set
	41			GRPC PR FLTVALUE	0 = Open 1 = Closed		0	—	—	Get/Set
	42			GRPC DN FLTSTATE	0 = Go to FltValue (#43) 1 = Ignore Trip		0	—	—	Get/Set
	43			GRPC DN FLTVALUE	0 = Open 1 = Closed		0	—	—	Get/Set
	44			GRPC DN IDLSTATE	0 = Go to FltValue (#45) 1 = Ignore Trip		0	—	—	Get/Set
	45			GRPC DN IDLVALUE	0 = Open 1 = Closed		0	—	—	Get/Set

Group	DeviceNet Param No.	Modbus Register		Parameter Name	Min	Max	Default	Scale Factor	Units	Access
		Read (0x03h)	Write (0x06h)							
Miscellaneous	46			SET TO DEFAULTS	0 = No action		0	—	—	Get/Set
					1 = Set all defaults		0			
					2 = Set DeviceNet defaults		0			
					3 = Set 825-P relay defaults		0			
DeviceLogix	50			NETWORK INPUTS 1...16	0 = Net IN1		0	—	—	Get
					1 = Net IN2		0			
					2 = Net IN3		0			
					3 = Net IN4		0			
					4 = Net IN5		0			
					5 = Net IN6		0			
					6 = Net IN7		0			
					7 = Net IN8		0			
					8 = Net IN9		0			
					9 = Net IN10		0			
					10 = Net IN11		0			
					11 = Net IN12		0			
					12 = Net IN13		0			
					13 = Net IN14		0			
					14 = Net IN15		0			
					15 = Net IN16		0			
					DeviceLogix	51			NETWORK INPUTS 17...32	
1 = Net IN18		0								
2 = Net IN19		0								
3 = Net IN20		0								
4 = Net IN21		0								
5 = Net IN22		0								
6 = Net IN23		0								
7 = Net IN24		0								
8 = Net IN25		0								
9 = Net IN26		0								
10 = Net IN27		0								
11 = Net IN28		0								
12 = Net IN29		0								
13 = Net IN30		0								
14 = Net IN31		0								
15 = Net IN32		0								

Group	DeviceNet Param No.	Modbus Register		Parameter Name	Min	Max	Default	Scale Factor	Units	Access
		Read (0x03h)	Write (0x06h)							
DeviceLogix (cont.)	52			NETWORK OUTPUTS	0 = Net OUT1 1 = Net OUT2 2 = Net OUT3 3 = Net OUT4 4 = Net OUT5 5 = Net OUT6 6 = Net OUT7 7 = Net OUT8 8 = Net OUT9 9 = Net OUT10 10 = Net OUT11 11 = Net OUT12 12 = Net OUT13 13 = Net OUT14 14 = Net OUT15 15 = Net OUT16		0 0 0 0 0 0 0 0 0 0 0 0 0 0 0	—	—	Get
	53			NETWORK OVERRIDE	0 = Disabled 1 = Enabled		0 0	—	—	Get/Set
	54			COMM OVERRIDE	0 = Disabled 1 = Enabled		0 0	—	—	Get/Set
	55			NET OUT COS MASK	0 = Net OUT1 1 = Net OUT2 2 = Net OUT3 3 = Net OUT4 4 = Net OUT5 5 = Net OUT6 6 = Net OUT7 7 = Net OUT8 8 = Net OUT9 9 = Net OUT10 10 = Net OUT11 11 = Net OUT12 12 = Net OUT13 13 = Net OUT14 14 = Net OUT15 15 = Net OUT16		0 0 0 0 0 0 0 0 0 0 0 0 0 0 0	—	—	Get/Set

Group	DeviceNet Param No.	Modbus Register		Parameter Name	Min	Max	Default	Scale Factor	Units	Access
		Read (0x03h)	Write (0x06h)							
Main Settings	101	40002	400002	PHASE ROTATION	0 = ABC 1 = ACB		0	—	—	Get/Set
	102	40003	400003	RATED FREQ.	0 = 50 1 = 60		1	—	Hz	Get/Set
	103	40004	400004	DATE FORMAT	0 = MDY 1 = YMD 2 = DMY		0	—	—	Get/Set
	104	40005	400005	PHASE CT RATIO	1	5000	1	1	—	Get/Set
	105	40006	400006	MOTOR FLA(le)	5	50000	5	10	A	Get/Set
	106	40007	400007	TWO SPEED ENABLE	0 = N 1 = Y		0	—	—	Get/Set
	107	40008	400008	CT RATIO-2nd	1	5000	1	1	—	Get/Set
	108	40009	400009	MOTOR FLA-2nd	5	50000	5	10	A	Get/Set
	109	40010	400010	CORE B. CT RATIO	1	2000	100	1	—	Get/Set
	110	40011	400011	PHASE VT RATIO	100	25000	1	100	—	Get/Set
	111	40012	400012	LINE VOLTAGE	100	30000	100	1	—	Get/Set
		112	40013	400013	XFMR CONNECTION	0 = Delta 1 = Wye		0	—	—
Overload Set	113	40014	400014	OVERLOAD ENABLE	0 = N 1 = Y		1	—	—	Get/Set
	114	40015	400015	OL RESET MODE	0 = Manual 1 = Auto		0	—	—	Get/Set
	115	40016	400016	OL RESET LEVEL	10	99	75	1	%TCU	Get/Set
	116	40017	400017	SERVICE FACTOR	101	150	101	100	—	Get/Set
	117	40018	400018	MOTOR LRC	25	120	60	10	x le	Get/Set
	118	40019	400019	LOCKD ROTOR TIME	10	6000	100	10	s	Get/Set
	119	40020	400020	ACCEL FACTOR	10	150	100	100	—	Get/Set
	120	40021	400021	RUN STATE TIME K	0 = Auto	2000	0	1	min	Get/Set
	121	40022	400022	MOTOR LRC - 2nd	25	120	60	10	x le	Get/Set
	122	40023	400023	MOTOR LRT - 2nd	10	6000	100	10	s	Get/Set
	123	40024	400024	ACCEL FACT - 2nd	10	150	100	100	—	Get/Set
	124	40025	400025	RUN ST TC - 2nd	0 = Auto	2000	0	1	min	Get/Set
	125	40026	400026	OL WARN ENABLE	0 = N 1 = Y		1	—	—	Get/Set
	126	40027	400027	OL WARN LEVEL	50	99	85	1	%TCU	Get/Set
	127	40028	400028	START INH. LEVEL	0 = Off	99	0	1	%TCU	Get/Set
	128	40029	400029	STOP COOL TIME	1	2200	18	1	min	Get/Set
	129	40030	400030	OL RTD BIASING	0 = N 1 = Y		0	—	—	Get/Set

Group	DeviceNet Param No.	Modbus Register		Parameter Name	Min	Max	Default	Scale Factor	Units	Access
		Read (0x03h)	Write (0x06h)							
Short Ckt Set	130	40031	400031	SC TRIP ENABLE	0 = N 1 = Y		0	—	—	Get/Set
	131	40032	400032	SC TRIP LEVEL	400	1200	1000	100	x le	Get/Set
	132	40033	400033	SC TRIP DELAY	0	500	0	100	s	Get/Set
	133	40034	400034	SC WARN ENABLE	0 = N 1 = Y		0	—	—	Get/Set
	134	40035	400035	SC WARN LEVEL	400	1200	1000	100	x le	Get/Set
	135	40036	400036	SC WARN DELAY	0	500	50	100	s	Get/Set
GF-CB Settings	136	40037	400037	GF-CB TRIP EN	0 = N 1 = Y		0	—	—	Get/Set
	137	40038	400038	GF-CB TRIP LEVEL	1	2500	100	100	A	Get/Set
	138	40039	400039	GF-CB TRIP DELAY	0	500	0	100	s	Get/Set
	139	40040	400040	GF-CB WARN EN	0 = N 1 = Y		0	—	—	Get/Set
	140	40041	400041	GF-CB WARN LEVEL	1	2500	100	100	A	Get/Set
	141	40042	400042	GF-CB WARN DELAY	0	500	0	100	s	Get/Set
GF-Res Settings	142	40043	400043	GF-RES TRIP EN	0 = N 1 = Y		0	—	—	Get/Set
	143	40044	400044	GF-RES TRIP LEVL	10	100	50	100	x le	Get/Set
	144	40045	400045	GF-RES TRIP DLAY	0	500	0	100	s	Get/Set
	145	40046	400046	GF-RES WARN EN	0 = N 1 = Y		0	—	—	Get/Set
	146	40047	400047	GF-RES WARN LEVL	10	100	50	100	x le	Get/Set
	147	40048	400048	GF-RES WARN DLAY	0	500	0	100	s	Get/Set
Jam Settings	148	40049	400049	JAM TRIP ENABLE	0 = N 1 = Y		0	—	—	Get/Set
	149	40050	400050	JAM TRIP LEVEL	100	600	200	100	x le	Get/Set
	150	40051	400051	JAM TRIP DELAY	0	1200	0	10	s	Get/Set
	151	40052	400052	JAM WARN ENABLE	0 = N 1 = Y		0	—	—	Get/Set
Undercurrent Set	154	40055	400055	UC TRIP ENABLE	0 = N		0	—	—	Get/Set
	155	40056	400056	UC TRIP LEVEL	10	100	50	100	x le	Get/Set
	156	40057	400057	UC TRIP DELAY	0	1200	50	10	s	Get/Set
	157	40058	400058	UC WARN ENABLE	0 = N 1 = Y		0	—	—	Get/Set
	158	40059	400059	UC WARN LEVEL	10	100	50	100	x le	Get/Set
	159	40060	400060	UC WARN DELAY	0	1200	100	10	s	Get/Set
	160	40061	400061	UC START INHIBIT	0	1500	0	1	s	Get/Set

Group	DeviceNet Param No.	Modbus Register		Parameter Name	Min	Max	Default	Scale Factor	Units	Access
		Read (0x03h)	Write (0x06h)							
Current Imb Set	161	40062	400062	CI TRIP ENABLE	0 = N 1 = Y		0	—	—	Get/Set
	162	40063	400063	CI TRIP LEVEL	5	80	15	1	%	Get/Set
	163	40064	400064	CI TRIP DELAY	0	240	5	1	s	Get/Set
	164	40065	400065	CI WARN ENABLE	0 = N 1 = Y		0	—	—	Get/Set
	165	40066	400066	CI WARN LEVEL	5	80	10	1	%	Get/Set
	166	40067	400067	CI WARN DELAY	0	240	10	1	s	Get/Set
Prot. Disable	167	40068	400068	PROT INHIBT TIME	0 = Off	240	0	1	s	Get/Set
	168	40069	400069	OL INHIBT TIME	0 = Off	240	0	1	s	Get/Set
Start Monitoring	169	40070	400070	START MOTOR TIME	0 = Off	240	0	1	s	Get/Set
Star Delta Set	170	40071	400071	STAR-DELTA ENABL	0 = N 1 = Y		0	—	—	Get/Set
	171	40072	400072	MAX STAR TIME	0 = Off	600	0	1	s	Get/Set
Start Inhbt	172	40073	400073	STARTS/HR	0 = Off	15	0	1	—	Get/Set
	173	40074	400074	MIN. OFF TIME	0 = Off	150	0	1	min	Get/Set
Antibackspin	174	40075	400075	RESTART BLK TIME	0 = Off	60	0	1	min	Get/Set
Phase Rev Set	175	40076	400076	PH REV. ENABLE	0 = N 1 = Y		0	—	—	Get/Set
Speed Sw Set	176	40077	400077	SS TRIP DELAY	0 = Off	240	0	1	s	Get/Set
	177	40078	400078	SS WARN DELAY	0 = Off	240	0	1	s	Get/Set
PTC Settings	178	40079	400079	PTC ENABLE	0 = N 1 = Y		0	—	—	Get/Set
	179	40080	400080	PTC RESET MODE	0 = Manual 1 = Auto		0	—	—	Get/Set
RTD Settings	180	40081	400081	RTD ENABLE	0 = N 1 = Y		0	—	—	Get/Set
	181	40082	400082	RTD RESET MODE	0 = Manual 1 = Auto		0	—	—	Get/Set
	182	40083	400083	RTD1 LOCATION	0 = Off 1 = Wdg 2 = Brg 3 = Amb 4 = Oth		0	—	—	Get/Set
	183	40084	400084	RTD1 TYPE	0 = Pt100 1 = Ni100 2 = Ni120 3 = Cu10		0	—	—	Get/Set
	184	40085	400085	RTD1 TRIP LEVEL	0 = Off	250	0	1	°C	Get/Set
	185	40086	400086	RTD1 WARN LEVEL	0 = Off	250	0	1	°C	Get/Set

Group	DeviceNet Param No.	Modbus Register		Parameter Name	Min	Max	Default	Scale Factor	Units	Access
		Read (0x03h)	Write (0x06h)							
RTD Settings (cont.)	186	40087	400087	RTD2 LOCATION	0 = Off 1 = Wdg 2 = Brg 3 = Amb 4 = Oth		0	—	—	Get/Set
	187	40088	400088	RTD2 TYPE	0 = Pt100		0	—	—	Get/Set
	188	40089	400089	RTD2 TRIP LEVEL	0 = Off	250	0	1	°C	Get/Set
	189	40090	400090	RTD2 WARN LEVEL	0 = Off	250	0	1	°C	Get/Set
	190	40091	400091	RTD3 LOCATION	0 = Off 1 = Wdg 2 = Brg 3 = Amb		0	—	—	Get/Set
	191	40092	400092	RTD3 TYPE	0 = Pt100		0	—	—	Get/Set
	192	40093	400093	RTD3 TRIP LEVEL	0 = Off	250	0	1	°C	Get/Set
	193	40094	400094	RTD3 WARN LEVEL	0 = Off	250	0	1	°C	Get/Set
	194	40095	400095	RTD4 LOCATION	0 = Off 1 = Wdg 2 = Brg 3 = Amb 4 = Oth		0	—	—	Get/Set
	195	40096	400096	RTD4 TYPE	0 = Pt100 1 = Ni100 2 = Ni120 3 = Cu10		0	—	—	Get/Set
	196	40097	400097	RTD4 TRIP LEVEL	0 = Off	250	0	1	°C	Get/Set
	197	40098	400098	RTD4 WARN LEVEL	0 = Off	250	0	1	°C	Get/Set
	198	40099	400099	RTD5 LOCATION	0 = Off		0	—	—	Get/Set
	199	40100	400100	RTD5 TYPE	0 = Pt100		0	—	—	Get/Set
	200	40101	400101	RTD5 TRIP LEVEL	0 = Off	250	0	1	°C	Get/Set
	201	40102	400102	RTD5 WARN LEVEL	0 = Off	250	0	1	°C	Get/Set
	202	40103	400103	RTD6 LOCATION	0 = Off 1 = Wdg 2 = Brg 3 = Amb 4 = Oth		0	—	—	Get/Set
	203	40104	400104	RTD6 TYPE	0 = Pt100 1 = Ni100 2 = Ni120 3 = Cu10		0	—	—	Get/Set
	204	40105	400105	RTD6 TRIP LEVEL	0 = Off	250	0	1	°C	Get/Set
	205	40106	400106	RTD6 WARN LEVEL	0 = Off	250	0	1	°C	Get/Set
206	40107	400107	RTD7 LOCATION	0 = Off 1 = Wdg 2 = Brg 3 = Amb		0	—	—	Get/Set	

Group	DeviceNet Param No.	Modbus Register		Parameter Name	Min	Max	Default	Scale Factor	Units	Access
		Read (0x03h)	Write (0x06h)							
RTD Settings (cont.)	207	40108	400108	RTD7 TYPE	0 = Pt100 1 = Ni100 2 = Ni120 3 = Cu10		0	—	—	Get/Set
	208	40109	400109	RTD7 TRIP LEVEL	0 = Off	250	0	1	°C	Get/Set
	209	40110	400110	RTD7 WARN LEVEL	0 = Off	250	0	1	°C	Get/Set
	210	40111	400111	RTD8 LOCATION	0 = Off 1 = Wdg 2 = Brg 3 = Amb 4 = Oth		0	—	—	Get/Set
	211	40112	400112	RTD8 TYPE	0 = Pt100 1 = Ni100 2 = Ni120 3 = Cu10		0	—	—	Get/Set
	212	40113	400113	RTD8 TRIP LEVEL	0 = Off	250	0	1	°C	Get/Set
	213	40114	400114	RTD8 WARN LEVEL	0 = Off	250	0	1	°C	Get/Set
	214	40115	400115	RTD9 LOCATION	0 = Off 1 = Wdg 2 = Brg 3 = Amb 4 = Oth		0	—	—	Get/Set
	215	40116	400116	RTD9 TYPE	0 = Pt100 1 = Ni100 2 = Ni120 3 = Cu10		0	—	—	Get/Set
	216	40117	400117	RTD9 TRIP LEVEL	0 = Off	250	0	1	°C	Get/Set
	217	40118	400118	RTD9 WARN LEVEL	0 = Off	250	0	1	°C	Get/Set
	218	40119	400119	RTD10 LOCATION	0 = Off 1 = Wdg 2 = Brg 3 = Amb 4 = Oth		0	—	—	Get/Set
	219	40120	400120	RTD10 TYPE	0 = Pt100 1 = Ni100 2 = Ni120 3 = Cu10		0	—	—	Get/Set
	220	40121	400121	RTD10 TRIP LEVEL	0 = Off	250	0	1	°C	Get/Set
	221	40122	400122	RTD10 WARN LEVEL	0 = Off	250	0	1	°C	Get/Set
222	40123	400123	RTD11 LOCATION	0 = Off 1 = Wdg 2 = Brg 3 = Amb 4 = Oth		0	—	—	Get/Set	

Group	DeviceNet Param No.	Modbus Register		Parameter Name	Min	Max	Default	Scale Factor	Units	Access
		Read (0x03h)	Write (0x06h)							
RTD Settings (cont.)	223	40124	400124	RTD11 TYPE	0 = Pt100 1 = Ni100 2 = Ni120 3 = Cu10		0	—	—	Get/Set
	224	40125	400125	RTD11 TRIP LEVEL	0 = Off	250	0	1	°C	Get/Set
	225	40126	400126	RTD11 WARN LEVEL	0 = Off	250	0	1	°C	Get/Set
	226	40127	400127	RTD12 LOCATION	0 = Off 1 = Wdg 2 = Brg 3 = Amb 4 = Oth		0	—	—	Get/Set
	227	40128	400128	RTD12 TYPE	0 = Pt100 1 = Ni100 2 = Ni120 3 = Cu10		0	—	—	Get/Set
	228	40129	400129	RTD12 TRIP LEVEL	0 = Off	250	0	1	°C	Get/Set
	229	40130	400130	RTD12 WARN LEVEL	0 = Off	250	0	1	°C	Get/Set
	230	40131	400131	WIND TRIP VOTING	0 = N 1 = Y		0	—	—	Get/Set
	231	40132	400132	BEAR TRIP VOTING	0 = N 1 = Y		0	—	—	Get/Set
	232	40133	400133	TMP RTD BIASING	0 = N 1 = Y		0	—	—	Get/Set
Undervoltage Set	233	40134	400134	UV TRIP ENABLE	0 = N 1 = Y		0	—	—	Get/Set
	234	40135	400135	UV TRIP LEVEL	60	100	80	100	x Vnm	Get/Set
	235	40136	400136	UV TRIP DELAY	0	1200	0	10	s	Get/Set
	236	40137	400137	UV WARN ENABLE	0 = N 1 = Y		0	—	—	Get/Set
	237	40138	400138	UV WARN LEVEL	60	100	80	100	x Vnm	Get/Set
	238	40139	400139	UV WARN DELAY	0	1200	0	10	s	Get/Set
Overvoltage Set	239	40140	400140	OV TRIP ENABLE	0 = N 1 = Y		0	—	—	Get/Set
	240	40141	400141	OV TRIP LEVEL	100	120	110	100	x Vnm	Get/Set
	241	40142	400142	OV TRIP DELAY	0	1200	0	10	s	Get/Set
	242	40143	400143	OV WARN ENABLE	0 = N 1 = Y		0	—	—	Get/Set
	243	40144	400144	OV WARN LEVEL	100	120	110	100	x Vnm	Get/Set
	244	40145	400145	OV WARN DELAY	0	1200	0	10	s	Get/Set

Group	DeviceNet Param No.	Modbus Register		Parameter Name	Min	Max	Default	Scale Factor	Units	Access
		Read (0x03h)	Write (0x06h)							
VAR Settings	245	40146	400146	NEG VAR TRIP EN	0 = N		0	—	—	Get/Set
	246	40147	400147	NEG VAR TRIP LEV	1	2500	2500	1	kVAR	Get/Set
	247	40148	400148	POS VAR TRIP EN	0 = N 1 = Y		0	—	—	Get/Set
	248	40149	400149	POS VAR TRIP LEV	1	2500	2500	1	kVAR	Get/Set
	249	40150	400150	VAR TRIP DELAY	0	240	0	1	s	Get/Set
	250	40151	400151	NEG VAR WARN EN	0 = N 1 = Y		0	—	—	Get/Set
	251	40152	400152	NEG VAR WARN LEV	1	2500	2500	1	kVAR	Get/Set
	252	40153	400153	POS VAR WARN EN	0 = N 1 = Y		0	—	—	Get/Set
	253	40154	400154	POS VAR WARN LEV	1	2500	2500	1	kVAR	Get/Set
	254	40155	400155	VAR WARN DELAY	0	240	0	1	s	Get/Set
Underpower Set	255	40156	400156	UP TRIP ENABLE	0 = N 1 = Y		0	—	—	Get/Set
	256	40157	400157	UP TRIP LEVEL	1	2500	2500	1	kW	Get/Set
	257	40158	400158	UP TRIP DELAY	0	240	0	1	s	Get/Set
	258	40159	400159	UP WARN ENABLE	0 = N 1 = Y		0	—	—	Get/Set
	259	40160	400160	UP WARN LEVEL	1	2500	2500	1	kW	Get/Set
	260	40161	400161	UP WARN DELAY	0	240	0	1	s	Get/Set
Power Factor Set	261	40162	400162	PF LAG TRIP ENBL	0 = N 1 = Y		0	—	—	Get/Set
	262	40163	400163	PF LAG TRIP LEVL	5	99	50	100	—	Get/Set
	263	40164	400164	PF LD TRIP ENABL	0 = N 1 = Y		0	—	—	Get/Set
	264	40165	400165	PF LD TRIP LEVL	5	99	50	100	—	Get/Set
	265	40166	400166	PF TRIP DELAY	0	240	0	1	s	Get/Set
	266	40167	400167	PF LAG WARN ENBL	0 = N	0	—	—	Get/Set	
	267	40168	400168	PF LAG WARN LEVL	5	99	50	100	—	Get/Set
	268	40169	400169	PF LD WARN ENABL	0 = N 1 = Y		0	—	—	Get/Set
	269	40170	400170	PF LD WARN LEVL	5	99	50	100	—	Get/Set
	270	40171	400171	PF WARN DELAY	0	240	0	1	s	Get/Set

Group	DeviceNet Param No.	Modbus Register		Parameter Name	Min	Max	Default	Scale Factor	Units	Access
		Read (0x03h)	Write (0x06h)							
Freq Settings	271	40172	400172	FREQ1 TRIP ENABL	0 = N 1 = Y		0	—	—	Get/Set
	272	40173	400173	FREQ1 TRIP LEVEL	450	650	600	10	Hz	Get/Set
	273	40174	400174	FREQ1 TRIP DELAY	0	2400	10	10	s	Get/Set
	274	40175	400175	FREQ1 WARN ENABL	0 = N 1 = Y		0	—	—	Get/Set
	275	40176	400176	FREQ1 WARN LEVEL	450	650	600	10	Hz	Get/Set
	276	40177	400177	FREQ1 WARN DELAY	0	2400	10	10	s	Get/Set
	277	40178	400178	FREQ2 TRIP ENABL	0 = N 1 = Y		0	—	—	Get/Set
	278	40179	400179	FREQ2 TRIP LEVEL	450	650	600	10	Hz	Get/Set
	279	40180	400180	FREQ2 TRIP DELAY	0	2400	10	10	s	Get/Set
	280	40181	400181	FREQ2 WARN ENABL	0 = N 1 = Y		0	—	—	Get/Set
	281	40182	400182	FREQ2 WARN LEVEL	450	650	600	10	Hz	Get/Set
	282	40183	400183	FREQ2 WARN DELAY	0	2400	10	10	s	Get/Set
Load Control Set	283	40184	400184	LOAD CONTROL SEL	0 = Off 1 = Current 2 = Power 3 = TCU		0	—	—	Get/Set
	284	40185	400185	LD CTL UPP ENABL	0 = N 1 = Y		0	—	—	Get/Set
	285	40186	400186	LD CTL CUR UPPER	20	200	50	10	x Ie	Get/Set
	286	40187	400187	LD CTL PWR UPPER	1	25000	22500	1	kW	Get/Set
	287	40188	400188	LD CTL TCU UPPER	1	99	90	1	%TCU	Get/Set
	288	40189	400189	LD CTL LOW ENABL	0 = N 1 = Y		0	—	—	Get/Set
	289	40190	400190	LD CTL CUR LOWER	20	200	50	10	x Ie	Get/Set
	290	40191	400191	LD CTL PWR LOWER	1	25000	12500	1	kW	Get/Set
	291	40192	400192	LD CTL TCU LOWER	1	99	90	1	%TCU	Get/Set

Group	DeviceNet Param No.	Modbus Register		Parameter Name	Min	Max	Default	Scale Factor	Units	Access
		Read (0x03h)	Write (0x06h)							
I/O Settings	292	40193	400193	ANALOG OUT SEL	0 = Load_I 1 = %Therm 2 = Wdg_RTD 3 = Brg_RTD 4 = PF 5 = Pwr_kW 6 = Avg_I 7 = Max_I		0	—	—	Get/Set
	293	40194	400194	TRIP INHIBIT	0 = Curr.Imbalance 1 = Jam 2 = Ground Fault 3 = Short Circuit 4 = Undercurrent 5 = Start Inhibit 6 = PTC 7 = RTD		0 0 0 0 0 0 0	—	—	Get/Set
	294	40195	400195	RELAY BEHAVIOR	0 = Trip Fail-Safe 1 = Aux1 Fail-Safe 2 = Aux2 Fail-Safe 3 = Aux3 Fail-Safe 4 = Aux4 Fail-Safe 5 = Aux5 Fail-Safe 6 = Aux6 Fail-Safe		1 1 1 1 1 1	—	—	Get/Set
Timer Settings	295	40196	400196	ON DELAY T1	0	240	0	1	s	Get/Set
	296	40197	400197	OFF DELAY T1	0	240	0	1	s	Get/Set
	297	40198	400198	ON DELAY T2	0	240	0	1	s	Get/Set
	298	40199	400199	OFF DELAY T2	0	240	0	1	s	Get/Set
Front Panel Set	299	40200	400200	LCD TIMEOUT	0 = Off	30	0	1	min	Get/Set
	300	40201	400201	LCD CONTRAST	1	8	0	1	—	Get/Set
	301	40202	400202	DISPLAY ENABLE	0 = Time & Date 1 = Ground Current 2 = Curr. Imbalance 3 = Frequency 4 = Therm Cap Used 5 = Volt Imbalance 6 = Power 7 = RTD Temp		0 0 0 0 0 0 0	—	—	Get/Set

Group	DeviceNet Param No.	Modbus Register		Parameter Name	Min	Max	Default	Scale Factor	Units	Access
		Read (0x03h)	Write (0x06h)							
I/O Mapping	302	40203	400203	TRIP ASSIGN LO	0 = Overload		0	—	—	Get/Set
					1 = Undercurrent		0			
					2 = Jam		0			
					3 = Curr. Imbalance		1			
					4 = Short Circuit		0			
					5 = RTD-Wind Bear		0			
					6 = PTC		0			
					7 = GF-Res		0			
					8 = VAR		0			
					9 = Underpower		0			
					10 = Undervoltage		0			
					11 = Overvoltage		0			
					12 = Phase Reversal		0			
					13 = Power Factor		0			
					14 = Speed Switch		0			
					15 = GF-CB		1			
	303	40204	400204	TRIP ASSIGN HI	0 = Start Time		0	—	—	Get/Set
					1 = Frequency 1		0			
					2 = Frequency 2		0			
					3 = RTD - Other		0			
					4 = RTD - Ambient		0			
					5 = PTC Error		0			
					6 = RTD Error		0			
					7 = MCM/CWE Error		0			
					8 = Comm Idle		0			
					9 = Comm Loss		0			
					10 = Remote Trip		0			
					11 = Comm Fault		0			
					12 = Reseved		0			
					13 = Reserved		0			
					14 = Reserved		0			
					15 = Reserved		0			

Group	DeviceNet Param No.	Modbus Register		Parameter Name	Min	Max	Default	Scale Factor	Units	Access
		Read (0x03h)	Write (0x06h)							
I/O Mapping (cont.)	304	40205	400205	AUX1 ASSIGN REG1	0 = Overload		0	—	—	Get/Set
					1 = Undercurrent		0			
					2 = Jam		0			
					3 = Curr. Imbalance		0			
					4 = Short Circuit		0			
					5 = RTD-Wind Bear		0			
					6 = PTC		0			
					7 = GF-Res		0			
					8 = VAR		0			
					9 = Underpower		0			
					10 = Undervoltage		0			
					11 = Overvoltage		0			
					12 = Phase Reversal		0			
					13 = Power Factor		0			
					14 = Speed Switch		0			
					15 = GF-CB		0			
	305	40206	400206	AUX1 ASSIGN REG2	0 = Start Time		0	—	—	Get/Set
					1 = Frequency 1		0			
					2 = Frequency 2		0			
					3 = RTD - Other		0			
					4 = RTD - Ambient		0			
					5 = PTC Error		0			
					6 = RTD Error		0			
					7 = MCM/CWE Error		0			
					8 = Comm Idle		0			
					9 = Comm Loss		0			
					10 = Remote Trip		0			
					11 = Comm Fault		0			
					12 = Latch Trip		0			
					13 = Reserved		0			
					14 = Reserved		0			
					15 = Reserved		0			

Group	DeviceNet Param No.	Modbus Register		Parameter Name	Min	Max	Default	Scale Factor	Units	Access
		Read (0x03h)	Write (0x06h)							
I/O Mapping (cont.)	306	40207	400207	AUX1 ASSIGN REG3	0 = RTD_Amb Warn		0	—	—	Get/Set
					1 = SALARM		1			
					2 = Warning		0			
					3 = Load Ctl Upper		0			
					4 = Load Ctl Lower		0			
					5 = Timer 1		0			
					6 = Timer 2		0			
					7 = Short Ckt Warn		0			
					8 = Stopped		0			
					9 = Running		0			
					10 = Starting		0			
					11 = Star		0			
					12 = Delta		0			
					13 = Start		0			
					14 = Network		0			
					15 = Reserved		0			
	307	40208	400208	AUX1 ASSIGN REG4	0 = Overload Warn		0	—	—	Get/Set
					1 = Undercurr Warn		0			
					2 = Jam Warn		0			
					3 = Curr. Imbal Warn		0			
					4 = RTD-W, B Warn		0			
					5 = Pwr Factor Warn		0			
					6 = GF-CB Warn		0			
					7 = GF-Res Warn		0			
					8 = VAR Warn		0			
					9 = Underpower Warn		0			
					10 = Undervolt Warn		0			
					11 = Overvolt Warn		0			
					12 = Spd Switch Warn		0			
					13 = Freq1 Warn		0			
					14 = Freq2 Warn		0			
					15 = RTD-OtherWarn		0			

Group	DeviceNet Param No.	Modbus Register		Parameter Name	Min	Max	Default	Scale Factor	Units	Access
		Read (0x03h)	Write (0x06h)							
I/O Mapping (cont.)	308	40209	400209	AUX2 ASSIGN REG1	0 = Overload		0	—	—	Get/Set
					1 = Undercurrent		0			
					2 = Jam		0			
					3 = Curr. Imbalance		0			
					4 = Short Circuit		0			
					5 = RTD-Wind Bear		0			
					6 = PTC		0			
					7 = GF-Res		0			
					8 = VAR		0			
					9 = Underpower		0			
					10 = Undervoltage		0			
					11 = Overvoltage		0			
					12 = Phase Reversal		0			
					13 = Power Factor		0			
					14 = Speed Switch		0			
					15 = GF-CB		0			
	309	40210	400210	AUX2 ASSIGN REG2	0 = Start Time		0	—	—	Get/Set
					1 = Frequency 1		0			
					2 = Frequency 2		0			
					3 = RTD - Other		0			
					4 = RTD - Ambient		0			
					5 = PTC Error		0			
					6 = RTD Error		0			
					7 = MCM/CWE Error		0			
					8 = Comm Idle		0			
					9 = Comm Loss		0			
					10 = Remote Trip		0			
					11 = Comm Fault		0			
					12 = Latch Trip		0			
					13 = Reserved		0			
					14 = Reserved		0			
					15 = Reserved		0			

Group	DeviceNet Param No.	Modbus Register		Parameter Name	Min	Max	Default	Scale Factor	Units	Access
		Read (0x03h)	Write (0x06h)							
I/O Mapping (cont.)	310	40211	400211	AUX2 ASSIGN REG3	0 = RTD_Amb Warn		0	—	—	Get/Set
					1 = SALARM		0			
					2 = Warning		0			
					3 = Load Ctl Upper		0			
					4 = Load Ctl Lower		0			
					5 = Timer 1		0			
					6 = Timer 2		0			
					7 = Short Ckt Warn		0			
					8 = Stopped		0			
					9 = Running		0			
					10 = Starting		0			
					11 = Star		0			
					12 = Delta		0			
					13 = Start		0			
					14 = Network		0			
					15 = Reserved		0			
	311	40212	400212	AUX2 ASSIGN REG4	0 = Overload Warn		0	—	—	Get/Set
					1 = Undercurr Warn		0			
					2 = Jam Warn		0			
					3 = Curr. Imbal Warn		0			
					4 = RTD-W, B Warn		0			
					5 = Pwr Factor Warn		0			
					6 = GF-CB Warn		0			
					7 = GF-Res Warn		0			
					8 = VAR Warn		0			
					9 = Underpower Warn		0			
					10 = Undervolt Warn		0			
					11 = Overvolt Warn		0			
					12 = Spd Switch Warn		0			
					13 = Freq1 Warn		0			
					14 = Freq2 Warn		0			
					15 = RTD-OtherWarn		0			

Group	DeviceNet Param No.	Modbus Register		Parameter Name	Min	Max	Default	Scale Factor	Units	Access
		Read (0x03h)	Write (0x06h)							
I/O Mapping (cont.)	312	40213	400213	AUX3 ASSIGN REG1	0 = Overload		0	—	—	Get/Set
					1 = Undercurrent		0			
					2 = Jam		0			
					3 = Curr. Imbalance		0			
					4 = Short Circuit		0			
					5 = RTD-Wind Bear		0			
					6 = PTC		0			
					7 = GF-Res		0			
					8 = VAR		0			
					9 = Underpower		0			
					10 = Undervoltage		0			
					11 = Overvoltage		0			
					12 = Phase Reversal		0			
					13 = Power Factor		0			
					14 = Speed Switch		0			
					15 = GF-CB		0			
	313	40214	400214	AUX3 ASSIGN REG2	0 = Start Time		0	—	—	Get/Set
					1 = Frequency 1		0			
					2 = Frequency 2		0			
					3 = RTD - Other		0			
					4 = RTD - Ambient		0			
					5 = PTC Error		0			
					6 = RTD Error		0			
					7 = MCM/CWE Error		0			
					8 = Comm Idle		0			
					9 = Comm Loss		0			
					10 = Remote Trip		0			
					11 = Comm Fault		0			
					12 = Latch Trip		0			
					13 = Reserved		0			
					14 = Reserved		0			
					15 = Reserved		0			

Group	DeviceNet Param No.	Modbus Register		Parameter Name	Min	Max	Default	Scale Factor	Units	Access
		Read (0x03h)	Write (0x06h)							
I/O Mapping (cont.)	314	40215	400215	AUX3 ASSIGN REG3	0 = RTD_Amb Warn		0	—	—	Get/Set
					1 = SALARM		0			
					2 = Warning		0			
					3 = Load Ctl Upper		0			
					4 = Load Ctl Lower		0			
					5 = Timer 1		0			
					6 = Timer 2		0			
					7 = Short Ckt Warn		0			
					8 = Stopped		0			
					9 = Running		0			
					10 = Starting		0			
					11 = Star		0			
					12 = Delta		0			
					13 = Start		0			
					14 = Network		0			
					15 = Reserved		0			
	315	40216	400216	AUX3 ASSIGN REG4	0 = Overload Warn		0	—	—	Get/Set
					1 = Undercurr Warn		0			
					2 = Jam Warn		0			
					3 = Curr. Imbal Warn		0			
					4 = RTD-W, B Warn		0			
					5 = Pwr Factor Warn		0			
					6 = GF-CB Warn		0			
					7 = GF-Res Warn		0			
					8 = VAR Warn		0			
					9 = Underpower Warn		0			
					10 = Undervolt Warn		0			
					11 = Overvolt Warn		0			
					12 = Spd Switch Warn		0			
					13 = Freq1 Warn		0			
					14 = Freq2 Warn		0			
					15 = RTD-OtherWarn		0			

Group	DeviceNet Param No.	Modbus Register		Parameter Name	Min	Max	Default	Scale Factor	Units	Access
		Read (0x03h)	Write (0x06h)							
I/O Mapping (cont.)	316	40217	400217	AUX4 ASSIGN REG1	0 = Overload		0	—	—	Get/Set
					1 = Undercurrent		0			
					2 = Jam		0			
					3 = Curr. Imbalance		0			
					4 = Short Circuit		0			
					5 = RTD-Wind Bear		0			
					6 = PTC		0			
					7 = GF-Res		0			
					8 = VAR		0			
					9 = Underpower		0			
					10 = Undervoltage		0			
					11 = Overvoltage		0			
					12 = Phase Reversal		0			
					13 = Power Factor		0			
					14 = Speed Switch		0			
					15 = GF-CB		0			
	317	40218	400218	AUX4 ASSIGN REG2	0 = Start Time		0	—	—	Get/Set
					1 = Frequency 1		0			
					2 = Frequency 2		0			
					3 = RTD - Other		0			
					4 = RTD - Ambient		0			
					5 = PTC Error		0			
					6 = RTD Error		0			
					7 = MCM/CWE Error		0			
					8 = Comm Idle		0			
					9 = Comm Loss		0			
					10 = Remote Trip		0			
					11 = Comm Fault		0			
					12 = Latch Trip		0			
					13 = Reserved		0			
					14 = Reserved		0			
					15 = Reserved		0			

Group	DeviceNet Param No.	Modbus Register		Parameter Name	Min	Max	Default	Scale Factor	Units	Access
		Read (0x03h)	Write (0x06h)							
I/O Mapping (cont.)	318	40219	400219	AUX4 ASSIGN REG3	0 = RTD_Amb Warn		0	—	—	Get/Set
					1 = SALARM		0			
					2 = Warning		0			
					3 = Load Ctl Upper		0			
					4 = Load Ctl Lower		0			
					5 = Timer 1		0			
					6 = Timer 2		0			
					7 = Short Ckt Warn		0			
					8 = Stopped		0			
					9 = Running		0			
					10 = Starting		0			
					11 = Star		0			
					12 = Delta		0			
					13 = Start		0			
					14 = Network		0			
					15 = Reserved		0			
	319	40220	400220	AUX4 ASSIGN REG4	0 = Overload Warn		0	—	—	Get/Set
					1 = Undercurr Warn		0			
					2 = Jam Warn		0			
					3 = Curr. Imbal Warn		0			
					4 = RTD-W, B Warn		0			
					5 = Pwr Factor Warn		0			
					6 = GF-CB Warn		0			
					7 = GF-Res Warn		0			
					8 = VAR Warn		0			
					9 = Underpower Warn		0			
					10 = Undervolt Warn		0			
					11 = Overvolt Warn		0			
					12 = Spd Switch Warn		0			
					13 = Freq1 Warn		0			
					14 = Freq2 Warn		0			
					15 = RTD-OtherWarn		0			

Group	DeviceNet Param No.	Modbus Register		Parameter Name	Min	Max	Default	Scale Factor	Units	Access
		Read (0x03h)	Write (0x06h)							
I/O Mapping (cont.)	320	40221	400221	AUX5 ASSIGN REG1	0 = Overload		0	—	—	Get/Set
					1 = Undercurrent		0			
					2 = Jam		0			
					3 = Curr. Imbalance		0			
					4 = Short Circuit		0			
					5 = RTD-Wind Bear		0			
					6 = PTC		0			
					7 = GF-Res		0			
					8 = VAR		0			
					9 = Underpower		0			
					10 = Undervoltage		0			
					11 = Overvoltage		0			
					12 = Phase Reversal		0			
					13 = Power Factor		0			
					14 = Speed Switch		0			
					15 = GF-CB		0			
	321	40222	400222	AUX5 ASSIGN REG2	0 = Start Time		0	—	—	Get/Set
					1 = Frequency 1		0			
					2 = Frequency 2		0			
					3 = RTD - Other		0			
					4 = RTD - Ambient		0			
					5 = PTC Error		0			
					6 = RTD Error		0			
					7 = MCM/CWE Error		0			
					8 = Comm Idle		0			
					9 = Comm Loss		0			
					10 = Remote Trip		0			
					11 = Comm Fault		0			
					12 = Latch Trip		0			
					13 = Reserved		0			
					14 = Reserved		0			
					15 = Reserved		0			

Group	DeviceNet Param No.	Modbus Register		Parameter Name	Min	Max	Default	Scale Factor	Units	Access
		Read (0x03h)	Write (0x06h)							
I/O Mapping (cont.)	322	40223	400223	AUX5 ASSIGN REG3	0 = RTD_Amb Warn		0	—	—	Get/Set
					1 = SALARM		0			
					2 = Warning		0			
					3 = Load Ctl Upper		0			
					4 = Load Ctl Lower		0			
					5 = Timer 1		0			
					6 = Timer 2		0			
					7 = Short Ckt Warn		0			
					8 = Stopped		0			
					9 = Running		0			
					10 = Starting		0			
					11 = Star		0			
					12 = Delta		0			
					13 = Start		0			
					14 = Network		0			
					15 = Reserved		0			
	323	40224	400224	AUX5 ASSIGN REG4	0 = Overload Warn		0	—	—	Get/Set
					1 = Undercurr Warn		0			
					2 = Jam Warn		0			
					3 = Curr. Imbal Warn		0			
					4 = RTD-W, B Warn		0			
					5 = Pwr Factor Warn		0			
					6 = GF-CB Warn		0			
					7 = GF-Res Warn		0			
					8 = VAR Warn		0			
					9 = Underpower Warn		0			
					10 = Undervolt Warn		0			
					11 = Overvolt Warn		0			
					12 = Spd Switch Warn		0			
					13 = Freq1 Warn		0			
					14 = Freq2 Warn		0			
					15 = RTD-OtherWarn		0			

Group	DeviceNet Param No.	Modbus Register		Parameter Name	Min	Max	Default	Scale Factor	Units	Access
		Read (0x03h)	Write (0x06h)							
I/O Mapping (cont.)	324	40225	400225	AUX6 ASSIGN REG1	0 = Overload		0	—	—	Get/Set
					1 = Undercurrent		0			
					2 = Jam		0			
					3 = Curr. Imbalance		0			
					4 = Short Circuit		0			
					5 = RTD-Wind Bear		0			
					6 = PTC		0			
					7 = GF-Res		0			
					8 = VAR		0			
					9 = Underpower		0			
					10 = Undervoltage		0			
					11 = Overvoltage		0			
					12 = Phase Reversal		0			
					13 = Power Factor		0			
					14 = Speed Switch		0			
					15 = GF-CB		0			
	325	40226	400226	AUX6 ASSIGN REG2	0 = Start Time		0	—	—	Get/Set
					1 = Frequency 1		0			
					2 = Frequency 2		0			
					3 = RTD - Other		0			
					4 = RTD - Ambient		0			
					5 = PTC Error		0			
					6 = RTD Error		0			
					7 = MCM/CWE Error		0			
					8 = Comm Idle		0			
					9 = Comm Loss		0			
					10 = Remote Trip		0			
					11 = Comm Fault		0			
					12 = Latch Trip		0			
					13 = Reserved		0			
					14 = Reserved		0			
					15 = Reserved		0			

Group	DeviceNet Param No.	Modbus Register		Parameter Name	Min	Max	Default	Scale Factor	Units	Access
		Read (0x03h)	Write (0x06h)							
I/O Mapping (cont.)	326	40227	400227	AUX6 ASSIGN REG3	0 = RTD_Amb Warn		0	—	—	Get/Set
					1 = SALARM		0			
					2 = Warning		0			
					3 = Load Ctl Upper		0			
					4 = Load Ctl Lower		0			
					5 = Timer 1		0			
					6 = Timer 2		0			
					7 = Short Ckt Warn		0			
					8 = Stopped		0			
					9 = Running		0			
					10 = Starting		0			
					11 = Star		0			
					12 = Delta		0			
					13 = Start		0			
					14 = Network		0			
					15 = Reserved		0			
	327	40228	400228	AUX6 ASSIGN REG4	0 = Overload Warn		0	—	—	Get/Set
					1 = Undercurr Warn		0			
					2 = Jam Warn		0			
					3 = Curr. Imbal Warn		0			
					4 = RTD-W, B Warn		0			
					5 = Pwr Factor Warn		0			
					6 = GF-CB Warn		0			
					7 = GF-Res Warn		0			
					8 = VAR Warn		0			
					9 = Underpower Warn		0			
					10 = Undervolt Warn		0			
					11 = Overvolt Warn		0			
					12 = Spd Switch Warn		0			
					13 = Freq1 Warn		0			
					14 = Freq2 Warn		0			
					15 = RTD-OtherWarn		0			

Group	DeviceNet Param No.	Modbus Register		Parameter Name	Min	Max	Default	Scale Factor	Units	Access
		Read (0x03h)	Write (0x06h)							
I/O Mapping (cont.)	328	40229	400229	IN1 ASSIGN	0=Emergency Start		0	—	—	Get/Set
					1=Disable Settings		0			
					2=Trip Reset		0			
					3=Timer 1		0			
					4=Timer 2		0			
					5=Speed Switch		0			
					6=Block Protection		0			
					7=Speed 2		0			
					8=Bkr/Cont Aux		0			
					9=Remote Trip		0			
					10=Reserved		0			
					11=Reserved		0			
					12=Reserved		0			
					13=Reserved		0			
					14=Reserved		0			
					15=Reserved		0			
	329	40230	400230	IN2 ASSIGN	0=Emergency Start		0	—	—	Get/Set
					1=Disable Settings		0			
					2=Trip Reset		0			
					3=Timer 1		0			
					4=Timer 2		0			
					5=Speed Switch		0			
					6=Block Protection		0			
					7=Speed 2		0			
					8=Bkr/Cont Aux		0			
					9=Remote Trip		0			
					10=Reserved		0			
					11=Reserved		0			
					12=Reserved		0			
					13=Reserved		0			
					14=Reserved		0			
					15=Reserved		0			

Group	DeviceNet Param No.	Modbus Register		Parameter Name	Min	Max	Default	Scale Factor	Units	Access
		Read (0x03h)	Write (0x06h)							
I/O Mapping (cont.)	330	40231	400231	IN3 ASSIGN	0=Emergency Start		0	—	—	Get/Set
					1=Disable Settings		0			
					2=Trip Reset		0			
					3=Timer 1		0			
					4=Timer 2		0			
					5=Speed Switch		0			
					6=Block Protection		0			
					7=Speed 2		0			
					8=Bkr/Cont Aux		0			
					9=Remote Trip		0			
					10=Reserved		0			
					11=Reserved		0			
					12=Reserved		0			
					13=Reserved		0			
					14=Reserved		0			
					15=Reserved		0			
	331	40232	400232	IN4 ASSIGN	0=Emergency Start		0	—	—	Get/Set
					1=Disable Settings		0			
					2=Trip Reset		0			
					3=Timer 1		0			
					4=Timer 2		0			
					5=Speed Switch		0			
					6=Block Protection		0			
					7=Speed 2		0			
					8=Bkr/Cont Aux		0			
					9=Remote Trip		0			
					10=Reserved		0			
					11=Reserved		0			
					12=Reserved		0			
					13=Reserved		0			
					14=Reserved		0			
					15=Reserved		0			

Group	DeviceNet Param No.	Modbus Register		Parameter Name	Min	Max	Default	Scale Factor	Units	Access
		Read (0x03h)	Write (0x06h)							
I/O Mapping (cont.)	332	40233	400233	INS ASSIGN	0=Emergency Start 1=Disable Settings 2=Trip Reset 3=Timer 1 4=Timer 2 5=Speed Switch 6=Block Protection 7=Speed 2 8=Bkr/Cont Aux 9=Remote Trip 10=Reserved 11=Reserved 12=Reserved 13=Reserved 14=Reserved 15=Reserved		0	—	—	Get/Set
	333	40234	400234	RESERVED	—	—	—	—	—	—
Reset Settings	334	40235	400235	RESET TRIP	0=Ready 1=Reset		0	—	—	Get/Set
	335	40236	400236	SET TO DEFAULTS	0=Ready 1=Reset		0	—	—	Get/Set
	336	40237	400237	RESET STAT DATA	0=Ready 1=Reset		0	—	—	Get/Set
	337	40238	400238	RESET HIS DATA	0=Ready 1=Reset		0	—	—	Get/Set
Date/Time Set	338	40239	400239	SET SEC	0	5999	0	100	—	Get/Set
	339	40240	400240	SET MIN	0	59	0	1	—	Get/Set
	340	40241	400241	SET HOUR	0	23	0	1	—	Get/Set
	341	40242	400242	SET DAY	1	31	1	1	—	Get/Set
	342	40243	400243	SET MONTH	1	12	1	1	—	Get/Set
	343	40244	400244	SET YEAR	2000	9999	2000	1	—	Get/Set

Group	DeviceNet Param No.	Modbus Register		Parameter Name	Min	Max	Default	Scale Factor	Units	Access
		Read (0x03h)	Write (0x06h)							
Current Data	344	40245		L1 CURRENT	0	65535	—	1	A	Get
	345	40246		L1 ANGLE	-1800	1800	—	10	°	Get
	346	40247		L2 CURRENT	0	65535	—	1	A	Get
	347	40248		L2 ANGLE	-1800	1800	—	10	°	Get
	348	40249		L3 CURRENT	0	65535	—	1	A	Get
	349	40250		L3 ANGLE	-1800	1800	—	10	°	Get
	350	40251		GF CURR (CORE B)	0	65535	—	1	A	Get
	351	40252		GF-CB ANGLE	-1800	1800	—	10	°	Get
	352	40253		GF CURR (RESID)	0	65535	—	1	A	Get
	353	40254		GF-RES ANGLE	-1800	1800	—	10	°	Get
	354	40255		AVERAGE CURRENT	0	65535	—	1	A	Get
	355	40256		MOTOR LOAD	0	120	—	10	x le	Get
	356	40257		CURRENT IMBAL	0	1000	—	10	%	Get
Voltage Data	357	40258		VAB	0	65535	—	1	V	Get
	358	40259		VAB ANGLE	-1800	1800	—	10	°	Get
	359	40260		VBC	0	65535	—	1	V	Get
	360	40261		VBC ANGLE	-1800	1800	—	10	°	Get
	361	40262		VCA	0	65535	—	1	V	Get
	362	40263		VCA ANGLE	-1800	1800	—	10	°	Get
	363	40264		AVERAGE LINE	0	65535	—	1	V	Get
	364	40265		VAN	0	65535	—	1	V	Get
	365	40266		VAN ANGLE	-1800	1800	—	10	°	Get
	366	40267		VBN	0	65535	—	1	V	Get
	367	40268		VBN ANGLE	-1800	1800	—	10	°	Get
	368	40269		VCN	0	65535	—	1	V	Get
	369	40270		VCN ANGLE	-1800	1800	—	10	°	Get
	370	40271		VG	0	65535	—	1	V	Get
	371	40272		VG ANGLE	-1800	1800	—	10	°	Get
	372	40273		AVERAGE PHASE	0	65535	—	1	V	Get
373	40274		VOLTAGE IMBAL	0	1000	—	10	%	Get	
Power Data	374	40275		REAL POWER	-32768	32767	—	1	kW	Get
	375	40276		REACTIVE POWER	-32768	32767	—	1	kVAR	Get
	376	40277		APPARENT POWER	-32768	32767	—	1	kVA	Get
	377	40278		POWER FACTOR	-100	100	—	100	—	Get

Group	DeviceNet Param No.	Modbus Register		Parameter Name	Min	Max	Default	Scale Factor	Units	Access
		Read (0x03h)	Write (0x06h)							
RTD Data	379	40280		MAX WINDING RTD	-32768	32767	—	1	°C	Get
	380	40281		MAX BEARING RTD	-32768	32767	—	1	°C	Get
	381	40282		MAX AMBIENT RTD	-32768	32767	—	1	°C	Get
	382	40283		MAX OTHER RTD	-32768	32767	—	1	°C	Get
	383	40284		RTD1	-32768	32767	—	1	°C	Get
	384	40285		RTD2	-32768	32767	—	1	°C	Get
	385	40286		RTD3	-32768	32767	—	1	°C	Get
	386	40287		RTD4	-32768	32767	—	1	°C	Get
	387	40288		RTD5	-32768	32767	—	1	°C	Get
	388	40289		RTD6	-32768	32767	—	1	°C	Get
	389	40290		RTD7	-32768	32767	—	1	°C	Get
	390	40291		RTD8	-32768	32767	—	1	°C	Get
	391	40292		RTD9	-32768	32767	—	1	°C	Get
	392	40293		RTD10	-32768	32767	—	1	°C	Get
	393	40294		RTD11	-32768	32767	—	1	°C	Get
	394	40295		RTD12	-32768	32767	—	1	°C	Get
	Overload Status	395	40296		RTD % TCU	0	100	—	1	%
396		40297		THERM CAP USED	0	9990	—	100	%	Get
397		40298		TIME TO TRIP	0	9999	—	1	s	Get
398		40299		STARTS AVAILABLE	0	255	—	1	—	Get
399		40300		TIME TO RESET	0	9999	—	1	s	Get
400		40301		Reserved	—	—	—	—	—	—

Group	DeviceNet Param No.	Modbus Register		Parameter Name	Min	Max	Default	Scale Factor	Units	Access
		Read (0x03h)	Write (0x06h)							
Motor Statistics	401	40302		ELAPSED TIME-mm	0	59	—	1	—	Get
	402	40303		ELAPSED TIME-hh	0	23	—	1	—	Get
	403	40304		ELAPSED TIME-dd	0	65535	—	1	—	Get
	404	40305		RUNNING TIME-mm	0	59	—	1	—	Get
	405	40306		RUNNING TIME-hh	0	23	—	1	—	Get
	406	40307		RUNNING TIME-dd	0	65535	—	1	—	Get
	407	40308		STOPPED TIME-mm	0	59	—	1	—	Get
	408	40309		STOPPED TIME-hh	0	23	—	1	—	Get
	409	40310		STOPPED TIME-dd	0	65535	—	1	—	Get
	410	40311		% TIME RUNNING	0	1000	—	10	—	Get
	411	40312		STARTS COUNT	0	65535	—	1	—	Get
	412	40313		EMER START COUNT	0	65535	—	1	—	Get
	413	40314		LAST RST TIME-ss	0	5999	—	1	—	Get
	414	40315		LAST RST TIME-mm	0	59	—	100	—	Get
	415	40316		LAST RST TIME-hh	0	23	—	1	—	Get
	416	40317		LAST RST DATE-dd	1	31	—	1	—	Get
	417	40318		LAST RST DATE-mm	1	12	—	1	—	Get
	418	40319		LAST RST DATE-yr	2000	9999	—	1	—	Get

Group	DeviceNet Param No.	Modbus Register		Parameter Name	Min	Max	Default	Scale Factor	Units	Access
		Read (0x03h)	Write (0x06h)							
Historical Data	419	40320		NO. EVENT LOGS	0	5	—	1	—	Get
	420	40321	400321	EVENT LOG SEL.	0	5	—	1	—	Get/Set
	421	40322		EVENT TIME ss	0	5999	—	1	—	Get
	422	40323		EVENT TIME mm	0	59	—	100	—	Get
	423	40324		EVENT TIME hh	0	23	—	1	—	Get
	424	40325		EVENT DAY dd	1	31	—	1	—	Get
	425	40326		EVENT DAY mm	1	12	—	1	—	Get
	426	40327		EVENT DAY yy	2000	9999	—	1	—	Get
	427	40328		EVENT TYPE	0=No Trip 1=Overload Trip 2=Lockd Rotor Trip 3=Undercurr Trip 4=Jam Trip 5=Curr Imbal Trip 6=Short Ckt Trip 7=Ground Flt Trip 8=Speed Sw Trip 9=Undervolt Trip 10=Overvolt Trip 11=Underpower Trip 12=Pwr Factor Trip 13=React Pwr Trip 14=Phase Rev Trip 15=Underfreq Trip 16=Overfreq Trip 17=RTD Trip 18=PTC Trip 19=Start Time Trip 20=MCM/CWE Fail 21=RTD Fail Trip 22=PTC Fail Trip 23=Reserved 24=Trigger 25=CommIdleLossTrip 26=Remote Trip 27=Comm Fail Trip 28=TestButton Trip		—	—	—	Get
	428	40329		EVENT L1	0	65535	—	1	A	Get

Group	DeviceNet Param No.	Modbus Register		Parameter Name	Min	Max	Default	Scale Factor	Units	Access
		Read (0x03h)	Write (0x06h)							
Historical Data (cont.)	429	40330		EVENT L2	0	65535	—	1	A	Get
	430	40331		EVENT L3	0	65535	—	1	A	Get
	431	40332		EVENT GF-RES	0	65535	—	1	A	Get
	432	40333		EVENT GF-CB	0	65535	—	1	A	Get
	433	40334		EVENT VAB/VAN	0	65535	—	1	V	Get
	434	40335		EVENT VBC/VBN	0	65535	—	1	V	Get
	435	40336		EVENT VCA/VCN	0	65535	—	1	V	Get
	436	40337		EVENT DELTA/WYE	0=Delta 1=Wye		—	—	—	Get
	437	40338		RESERVED	—	—	—	—	—	—
	438	40339		RESERVED	—	—	—	—	—	—
	439	40340		RESERVED	—	—	—	—	—	—
	440	40341		RESERVED	—	—	—	—	—	—
	441	40342		RESERVED	—	—	—	—	—	—
	442	40343		RESERVED	—	—	—	—	—	—
443	40344		RESERVED	—	—	—	—	—	—	
Trip/Warn Data	444	40345		TRIP STATUS LO	0=Overload 1=Undercurrent 2=Jam 3=Curr. Imbalance 4=Short Circuit 5=RTD-Wind Bear 6=PTC 7=GF-Res 8=VAR 9=Underpower 10=Undervoltage 11=Overvoltage 12=Phase Reversal 13=Power Factor 14=Speed Switch 15=GF-CB		—	—	—	Get

Group	DeviceNet Param No.	Modbus Register		Parameter Name	Min	Max	Default	Scale Factor	Units	Access
		Read (0x03h)	Write (0x06h)							
Trip/Warn Data (cont.)	445	40346		TRIP STATUS HI	0=Start Time 1=Frequency 1 2=Frequency 2 3=RTD - Other 4=RTD - Ambient 5=PTC Error 6=RTD Error 7=MCM/CWE Error 8=Comm Idle 9=Comm Loss 10=Remote Trip 11=Comm Fault 12=Alarm Critical 13=Reserved 14=Reserved 15=Reserved		—	—	—	Get
	446	40347		WARN STATUS LO	0=Overload Warn 1=Undercurr Warn 2=Jam Warn 3=Curr. Imbal Warn 4=Short Ckt Warn 5=RTD-W, B Warn 6=Reserved 7=GF-Res Warn 8=VAR Warn 9=Underpower Warn 10=Undervolt Warn 11=Overvolt Warn 12=Reserved 13=Pwr Factor Warn 14=Spd Switch Warn 15=GF-CB Warn		—	—	—	Get

Group	DeviceNet Param No.	Modbus Register		Parameter Name	Min	Max	Default	Scale Factor	Units	Access
		Read (0x03h)	Write (0x06h)							
Trip/Warn Data (cont.)	447	40348		WARN STATUS HI	0=Reserved		—	—	—	Get
					1=Freq1 Warn					
					2=Freq2 Warn					
					3=RTD-Other Warn					
					4=RTD-Amb Warn					
					5=PTC Error Warn					
					6=RTD Error Warn					
					7=MCM/CWE Err Warn					
					8=Comm Idle Warn					
					9=Comm Loss Warn					
					10=Reserved					
					11=Comm Fault Warn					
					12=Alarm Warn					
					13=Reserved					
					14=Reserved					
15=Reserved										

Relay Word Bits

Overview

The protection and control element results are represented by Relay Status bits in the 825-P relay. Each Relay Status bit has a label name and can be in either of the following states:

- 1 (logical ON)
- 0 (logical OFF)

Logical ON represents an element being picked up or otherwise asserted. Logical OFF represents an element being dropped out or otherwise de-asserted.

The Relay Word bits are collected into a table of 10 rows, each row containing 8 bits. The collection is called the Relay Word.

Table 112 shows a list of Relay Status bits and their descriptions. The Relay Word bit row numbers correspond to the row numbers used in the TAR command in MPS Explorer Software. For access from the front panel, use the following menu path:

Main Menu > Targets

Table 113 shows additional Relay Word bits that are not available for output mapping or for the display using the **TARGET** command. These bits are used in the relay Sequential Events Recorder (SER) records. (Chapter 8: Analyzing Events).

Definitions

Table 112 - Relay Word Bit Definitions for the 825-P (Sheet 1 of 4)

Row #	Bit	Definition	
0	ENABLE	7	front panel ENABLE LED.
	TRIP	6	front panel TRIP LED (see Chapter 3: Front Panel Operation)
	*	5	Reserved for future use.
	*	4	Reserved for future use.
	*	3	Reserved for future use.
	*	2	Reserved for future use.
	*	1	Reserved for future use.
	*	0	Reserved for future use.

Table 112 - Relay Word Bit Definitions for the 825-P (Sheet 2 of 4)

Row #	Bit	Definition
1	49T	7 Thermal (Overload) Trip. Assert when the relay issues a thermal element trip because of locked rotor starting or running overload conditions.
	LOSSTRIP	6 Load-Loss Trip. Assert when the relay detects a load-loss as defined by that function and its settings.
	JAMTRIP	5 Load-Jam Trip.
	46UBT	4 Phase Current Unbalance Trip. Assert when the relay issues a trip in response to a current unbalance condition, as defined by that function and its settings.
	50P1T	3 Definite-Time Phase Overcurrent (Short Circuit Trip Level.
	RTDT	2 Winding and Bearing RTD Overtemperature Trip.
	PTCTRIP	1 Asserts when measured PTC loop resistance is greater than trip value.
	50G1T	0 Definite-Time Residual Overcurrent (Trip Level.
2	VART	7 Reactive Power Trip. Assert when the relay issues a reactive power element trip.
	37PT	6 Underpower Trip. Assert when the relay issues an underpower element trip.
	27P1T	5 Phase Undervoltage Trip Definite time delayed.
	59P1T	4 Phase Overvoltage Trip Definite time delayed).
	47T	3 Phase Reversal Trip. Asserts when the relay detects a phase reversal condition.
	55T	2 Power Factor Trip. Assert when the relay issues a power factor element alarm or trip.
	SPDSTR	1 Speed Switch Trip. Asserts when the relay does not detect a speed switch contact closure within a settable trip period from the beginning of a motor start.
	50N1T	0 Definite-Time Neutral (Core Balance) Overcurrent.
3	SMTRIP	7 Asserts when Start Motor Timer times out.
	81D1T	6 Definite-Time Over- and Underfrequency Element (Trip Level 1). Assert when the frequency has been either above or below the element set point for a definite time.
	81D2T	5 Definite-Time Over- and Underfrequency Element (Trip Level 2). Assert when the frequency has been either above or below the element set point for a definite time.
	OTHTRIP	4 Other Temperature Trip. Asserts when one or more healthy Other RTD temperature exceeds the trip set points.
	AMBTRIP	3 Ambient Temperature Trip. Asserts when the healthy ambient RTD temperature exceeds its trip set point.
	PTCFLT	2 Indicates faulted/shorted thermistor.
	RTDFLT	1 Asserts when an open or short circuit condition is detected on any enabled RTD input, or communication with the external RTD module has been interrupted.
	MCMFLT	0 Asserts when the MCM module detected does not agree with the relay part number.
4	COMMIDLE	7 DeviceNet Card in programming mode.
	COMMLOSS	6 DeviceNet communication fail.
	REMTrip	5 Remote Trip Control Input Asserted.
	COMMFLT	4 Internal communication time-out.
	*	3 Reserved for future use.
	*	2 Reserved for future use.
	*	1 Reserved for future use.
	*	0 Reserved for future use.
5	49A	7 Thermal (Overload) Alarm. Assert when the relay issues a thermal element alarm/warning because of locked rotor starting or running overload conditions.
	LOSSALRM	6 Load-Loss Alarm/Warning. Assert when the relay detects a load-loss as defined by that function and its settings.
	JAMALRM	5 Load-Jam Alarm/Warning.

Table 112 - Relay Word Bit Definitions for the 825-P (Sheet 3 of 4)

Row #	Bit	Definition
	46UBA	4 Phase Current Unbalance Alarm. Assert when the relay issues an alarm/warning in response to a current unbalance condition, as defined by that function and its settings.
	RTDA	3 Winding/Bearing RTD Overtemperature Alarm/Warning.
	55A	2 Power Factor Alarm. Assert when the relay issues a power factor element alarm/warning.
	50N2T	1 Definite-Time Neutral (Core Balance) Overcurrent (Warning Level).
	50G2T	0 Definite-Time Residual Overcurrent (Warning Level).
6	VARA	7 Reactive Power Alarm. Assert when the relay issues a reactive power element alarm/warning.
	37PA	6 Underpower Alarm. Assert when the relay issues an underpower element alarm/warning.
	27P2T	5 Phase Undervoltage Alarm/Warning Definite time delayed.
	59P2T	4 Phase Overvoltage Alarm/Warning Definite time delayed.
	SPDSAL	3 Speed Switch Alarm. Asserts when the relay does not detect a speed switch contact closure within a settable warning period from the beginning of a motor start.
	81D1A	2 Definite-Time Over- and Underfrequency Element (Warning Level 1). Assert when the frequency has been either above or below the element set point for a definite time.
	81D2A	1 Definite-Time Over- and Underfrequency Element (Warning Level 2). Assert when the frequency has been either above or below the element set point for a definite time.
	OTHALRM	0 Other Temperature Alarm. Asserts when any healthy Other RTD temperature exceeds its alarm/warning set point.
7	AMBALRM	7 Ambient Temperature Alarm. Asserts if the healthy ambient RTD temperature exceeds its alarm/warning set point.
	SALARM	6 Pulses for the following conditions: Setting Changes, Access Level Changes, and three unsuccessful password entry attempts.
	WARNING	5 Asserts when any of the protection elements (warning level) operates or when the relay detects self-test failure (see Table 89), RTD/PTC faults, or DeviceNet communications alarms.
	LOADUP	4 Asserts when the selected load parameter exceeds an upper level setting (see Table 34).
	LOADLOW	3 Asserts when the selected load parameter drops below a lower level setting (see Table 34).
	TIMER1T	2 Output of the Timer Function logic (see Table 39).
	TIMER2T	1
	50P2T	0 Definite-Time Phase Overcurrent (Short Circuit Warning Level).
8	STOPPED	7 Asserts when the motor is stopped.
	RUNNING	6 Asserts when the motor is running.
	STARTING	5 Asserts when the protected motor is starting.
	STAR	4 Asserts when the Star-Delta Starting function issues a command to switch motor configuration to Star (see Star-Delta Starting on page 2-28).
	DELTA	3 Asserts when the Star-Delta Starting function issues a command to switch motor configuration to Delta (see Star-Delta Starting on page 2-28).
	START	2 Output of the motor start logic.
	*	1 Reserved for future use.
	*	0 Reserved for future use.
9	IN1	7 Control inputs IN1 . . . IN5 (inputs IN3 . . . IN5 are optional).
	IN2	6
	IN3	5
	IN4	4
	IN5	3
	*	2 Reserved for future use.

Table 112 - Relay Word Bit Definitions for the 825-P (Sheet 4 of 4)

Row #	Bit	Definition	
	*	1	Reserved for future use.
	*	0	Reserved for future use.
10	TRIP	7	Output of Trip Logic.
	AUX1	6	Output of AUX1 . . . AUX6 mapping (outputs AUX3 . . . AUX6 are optional).
	AUX2	5	
	AUX3	4	
	AUX4	3	
	AUX5	2	
	AUX6	1	
	*	0	Reserved for future use.

Table 113 - Additional 825-P Relay Status Bits for SER Command

Bit Name	Definition
THERMLO	Motor Lockout Conditions. Asserted by the thermal element (THERMLO).
NOSLO	Starts per hour function (NOSLO).
TBSLO	Minimum time between starts (TBSLO).
ABSLO	Anti-backspin timer (ABSLO).
SPEED2	Asserts when control input mapped to SPEED2 asserts.

ASCII Port Relay Command Summary

ASCII Port Relay

The ASCII Port Relay Command Summary table below lists the front serial port ASCII commands associated with particular activities. The commands are shown in upper-case letters, but they can also be entered with lower-case letters.

Serial Port Command	Access Level	Command Description
ZAC	1, 2	Go to Access Level 2.
ACC	0, 2	Go to Access Level 1.
ANA	2	Test analog output (refer to Chapter 12: ASCII Serial Communications for details).
DAT	1, 2	View date.
DAT <i>mm/dd/yyyy</i>	1, 2	Enter date in MDY format if DATE_F setting is MDY.
DAT <i>dd/mm/yyyy</i>	1, 2	Enter date in DMY format if DATE-F setting is DMY.
DAT <i>yyyy/mm/dd</i>	1, 2	Enter date in YMD format if DATE-F setting is YMD.
MET	1, 2	Display instantaneous metering data.
MET <i>k</i>	1, 2	Display instantaneous metering data <i>k</i> times, where <i>k</i> is 1...32767.
MET T	1, 2	Display thermal and RTD metering data.
MOT	1, 2	Display motor operating statistics report.
MOT R or C	2	Reset motor operating statistics.
PAS	2	Show existing Access Level 1 and Level 2 passwords.
PAS 1 <i>xxxxxxxx</i>	2	Change Access Level 1 password to <i>xxxxxxxx</i>
PAS 2 <i>xxxxxxxx</i>	2	Change Access Level 2 password to <i>xxxxxxxx</i>
QUI	1, 2	Go to Access Level 0.
SER	1, 2	Display all Sequential Events Recorder (SER) data.
SER <i>n</i>	1, 2	Display the <i>n</i> most recent SER records starting with record <i>n</i> .
SER <i>n1 n2</i>	1, 2	Display SER records <i>n2</i> ... <i>n1</i> , starting with <i>n2</i> .
SER <i>d1</i>	1, 2	Display all SER records made on date <i>d1</i> .
SER <i>d1 d2</i>	1, 2	Display all SER records made from dates <i>d2</i> ... <i>d1</i> , inclusive, starting with <i>d2</i> .
SER R or C	1, 2	Reset SER data.
SET	2	Enter/change relay settings.
SET P	2	Enter/change Serial Port F settings.
SET M	2	Enter/change I/O mapping settings.
SET <i>name</i>	2	For all SET commands, jump ahead to a specific setting by entering setting name, e.g., 50P1P .
SET ... TERSE	2	For all SET commands, TERSE disables the automatic SHO command after settings entry.
SHO	1, 2	Show relay settings.
SHO A	1, 2	Show all relay settings: enabled and disabled/hidden.

Serial Port Command	Access Level	Command Description
SHO P	1, 2	Show Serial Port F settings.
SHO M	1, 2	Show I/O mapping settings.
STA	1, 2	Display relay self-test status.
STA R or C	2	Clear self-test status and restart relay.
STO	2	Stop motor.
STR	2	Start motor.
SUM	1, 2	View event summary reports.
SUM R or C	1, 2	Reset event summary buffer.
TAR	1, 2	Display Relay Word Row 0 (front panel target LEDs).
TAR <i>n k</i>	1, 2	Display Relay Word Row <i>n</i> (<i>n</i> = 0 . . . 10). Repeat <i>k</i> times.
TAR <i>name k</i>	1, 2	Display Relay Word Row containing Relay Word <i>name</i> . Repeat <i>k</i> times.
TAR R	2	Reset front panel trip/target LEDs.
TIM	1, 2	View time.
TIM <i>hh:mm:ss</i>	1, 2	Set time by entering TIM followed by hours, minutes, and seconds, as shown (24-hour clock).

DeviceNet Information

Section	Page
Electronic Data Sheets	242
Product Codes	242
DeviceNet Objects	242
Identity Objects - CLASS CODE 0x0001	243
Message Router - CLASS CODE 0x0002	244
DeviceNet Object - CLASS CODE 0x0003	244
Assembly Object - CLASS CODE 0x0004	245
Custom Parameter-Based Input (Produced) Assembly Instance 100	246
Standard Input (Produced) Assemblies	247
Standard Output (Consumed) Assemblies	250
Connection Object - CLASS CODE 0x0005	251
Discrete Input Point Object - CLASS CODE 0x0008	254
Discrete Output Point Object - CLASS CODE 0x0009	255
Discrete Output Point Object Special Requirements	256
State Transition Diagram	256
Parameter Object - CLASS CODE 0x000F	257
Parameter Group Object - CLASS CODE 0x0010	258
Discrete Output Group Object - CLASS CODE 0x001E	259
Control Supervisor Object - CLASS CODE 0x0029	261
Acknowledge Handler Object - CLASS CODE 0x002b	261
Overload Object - CLASS CODE 0x002c	262
DeviceNet Interface Object - CLASS CODE 0x00B4	262

Electronic Data Sheets

Electronic Data Sheet (EDS) files are specially formatted ASCII files that provide all of the information necessary for a configuration tool (e.g., RSNetWorx for DeviceNet) to access and alter the parameters of a device. The EDS file contains all the parameter information of a device: number of parameters, groupings, parameter name, min, max, and default values, units, data format and scaling.

EDS files are available from the Internet at www.ab.com/networks/eds/index/html. They can also be built automatically by some configuration tools since all of the information necessary for an EDS file can be extracted from the 825-P Modular Protection System.

Product Codes

Configuration tools use product codes to identify which EDS file to use for a given device. The 825-P Modular Protection System has a product code of 100(64 hex).

DeviceNet Objects

The 825-P Modular Protection System supports the following DeviceNet object classes:

Table 114 - DeviceNet Object Classes

Class	Object
0x0001	Identity
0x0002	Message Router
0x0003	DeviceNet
0x0004	Assembly
0x0005	Connection
0x0008	Discrete Input Point
0x0009	Discrete Output Point
0x000F	Parameter Object
0x0010	Parameter Group Object
0x001E	Discrete Output Group
0x0029	Control Supervisor
0x002B	Acknowledge Handler
0x002C	Overload Object
0x00B4	DN Interface Object
0x00C2	PCP Object

Identity Object - CLASS CODE 0x0001

The following class attributes are supported for the Identity Object:

Attribute ID	Access Rule	Name	Data Type	Value
1	Get	Revision	UINT	1

The table below shows Instance 1 attributes of the Identity Object. Each instance of the Identity Object contains the following attributes:

Attribute ID	Access Rule	Name	Data Type	Value
1	Get	Vendor	UINT	1
2	Get	Device Type	UINT	3
3	Get	Produce Code	UINT	100 (64 hex)
4	Get	Revision Major Revision Minor Revision	Structure of UINT UINT	ORRRMMMM 0 = reserved by DeviceNet RRR = Revision of Motor Relay MMMM = Revision of DNet card
5	Get	Status	WORD	Bit 0 - 0=not owned; 1=owned by master Bit 2 - 0=Factory Defaulted; 1=Configured Bit 8 - Minor Recoverable fault Bit 9 - Minor Unrecoverable fault Bit 10 - Major Recoverable fault Bit 11 - Major Unrecoverable fault
6	Get	Serial Number	UDINT	Unique number for each device
7*	Get	Produce Name String Name ASCII String	Structure of USINT STRING	825-P
9	Get	Configuration Consistency Value	UINT	Unique value depending on output of the parameter checksum algorithm.

The following common services are implemented for the Identity Object:

Service Code	Implemented for:		Service Name
	Class	Instance	
0x0E	No	Yes	Get_Attribute_Single
0x05	No	Yes	Reset

**Message Router - CLASS
CODE 0x0002**

No class or instance attributes are supported. The message router object exists only to rout explicit messages to other objects.

**DeviceNet Object - CLASS
CODE 0x0003**

The following class attributes are supported for the DeviceNet Object:

Attribute ID	Access Rule	Name	Data Type	Value
1	Get	Revision	UINT	2

Only Instance 1 of the DeviceNet Object is supported. The following instance attributes are supported:

Attribute ID	Access Rule	Name	Data Type	Value
1	Get/Set	Node Address	USINT	0-63
2	Get/Set	Baud Rate	USINT	0=125K 1=250K 2=500K
5	Get	Allocation Info Allocation Choice Master Node Addr	Structure of BYTE USINT	Allocation_byte** 0-63 = address 255 = unallocated
8	Get	MAC ID Switch Value	USINT	0-63

** Allocation_byte Bit 0 Explicit messaging

Bit 1 Polled I/O

Bit 4 COS I/O

Bit 5 Cyclic I/O

Bit 6 Acknowledge Suppression

The following services are implemented for the DeviceNet Object:

Service Code	Implemented for:		Service Name
	Class	Instance	
0x0E	Yes	Yes	Get_Attribute_Single
0x10	No	Yes	Set_Attribute_Single
0x4E	No	Yes	Allocate_Master/Slave_Connection_Set
0x4C	No	Yes	Release_Master/Slave_Connection_Set

Assembly Object - CLASS CODE 0x0004

The following class attributes are supported for the Assembly Object:

Attribute ID	Access Rule	Name	Data Type	Value
2	Get	Max Instance	UINT	189

All of the various instances of the assembly object supports attribute 3, Data. Details about the specific content of the data attribute for each of the instances is described after the following summary Assembly Object Instance table:

Instance	Type	Description
2	Consumed	Required ODVA Consumed Instance
50	Produced	Required ODVA Produced Instance
51	Produced	ODVA Starter
100	Produced	Custom Parameter Based Word Wise Assembly
101	Produced	825 Average Current Overload
102	Produced	825 Phase Current Overload
103	Produced	825 Current Overload
104	Produced	825 Misc. Information Overload
150	Consumed	Standard Overload
151	Consumed	Standard Overload with Network Inputs
180	Produced	Auxiliary Inputs
181	Consumed	Auxiliary Outputs
182	Consumed	Consumed Network Bits 1 (also known as Network Inputs)
183	Consumed	Consumed Network Bits 2 (also known as Network Inputs)
184	Produced	Produced Network Bits (also known as Network Outputs)
185	Produced	Trip Status 1
186	Produced	Trip Status 2

Instance	Type	Description
187	Produced	Warn Status 1
188	Produced	Warn Status 2
189	Produced	Module Status Bits

Custom Parameter Based Input (Produced) Assembly Instance 100

Instance 100									
Word	Byte	Bit 7	Bit 6	Bit 5	Bit 4	Bit 3	Bit 2	Bit 1	Bit 0
0	0	Value of the parameter pointed to by "Produced Word 0 Param" (low byte)							
	1	Value of the parameter pointed to by "Produced Word 0 Param" (high byte)							
1	2	Value of the parameter pointed to by "Produced Word 1 Param" (low byte)							
	3	Value of the parameter pointed to by "Produced Word 1 Param" (high byte)							
2	4	Value of the parameter pointed to by "Produced Word 2 Param" (low byte)							
	5	Value of the parameter pointed to by "Produced Word 2 Param" (high byte)							
3	6	Value of the parameter pointed to by "Produced Word 3 Param" (low byte)							
	7	Value of the parameter pointed to by "Produced Word 3 Param" (high byte)							
4	8	Value of the parameter pointed to by "Produced Word 4 Param" (low byte)							
	9	Value of the parameter pointed to by "Produced Word 4 Param" (high byte)							
5	10	Value of the parameter pointed to by "Produced Word 5 Param" (low byte)							
	11	Value of the parameter pointed to by "Produced Word 5 Param" (high byte)							
6	12	Value of the parameter pointed to by "Produced Word 6 Param" (low byte)							
	13	Value of the parameter pointed to by "Produced Word 6 Param" (high byte)							
7	14	Value of the parameter pointed to by "Produced Word 7 Param" (low byte)							
	15	Value of the parameter pointed to by "Produced Word 7 Param" (high byte)							

Standard Input (Produced) Assemblies

Instance 50 is the required input (produced) assembly defined in the DeviceNet Motor Overload Profile.

Instance 50 ODVA Overload								
Byte	Bit 7	Bit 6	Bit 5	Bit 4	Bit 3	Bit 2	Bit 1	Bit 0
0								Fault

Instance 51 is the required input (produced) assembly defined in the DeviceNet Motor Starter Profile.

Instance 51 ODVA Starter								
Byte	Bit 7	Bit 6	Bit 5	Bit 4	Bit 3	Bit 2	Bit 1	Bit 0
0							Warning	Fault

Instance 101 is the 825 Average Current Overload Input (produced) assembly.

Instance 101 825 Average Current Overload								
Byte	Bit 7	Bit 6	Bit 5	Bit 4	Bit 3	Bit 2	Bit 1	Bit 0
0							Warning	Tripped
1	Reserved							
2	Average 3 Phase Current (low)							
3	Average 3 Phase Current (high)							

Instance 102 is the 825 Phase Current Input (produced) assembly.

Instance 102 825 Phase Current								
Byte	Bit 7	Bit 6	Bit 5	Bit 4	Bit 3	Bit 2	Bit 1	Bit 0
0							Warning	Tripped
1	Reserved							
2	Current Phase L1 (low)							
3	Current Phase L1 (high)							
4	Current Phase L2 (low)							
5	Current Phase L2 (high)							
6	Current Phase L3 (low)							
7	Current Phase L3 (high)							

Instance 103 is the 825 Current Input (produced) assembly.

Instance 103 825 Current								
Byte	Bit 7	Bit 6	Bit 5	Bit 4	Bit 3	Bit 2	Bit 1	Bit 0
0							Warning	Tripped
1	% Thermal Capacity Used							
2	Average 3 Phase Current (low)							
3	Average 3 Phase Current (high)							
4	% Asymmetry							

Instance 104 is the 825 Misc. Input (produced) assembly.

Instance 104 825 Phase Current								
Byte	Bit 7	Bit 6	Bit 5	Bit 4	Bit 3	Bit 2	Bit 1	Bit 0
0							Warning	Tripped
1	% Thermal Capacity Used							
2	Average 3 Phase Current (low)							
3	Average 3 Phase Current (high)							
4	% Asymmetry							
5	Max value of all Temperature sensors							
6	Earth Current (low)							
7	Earth Current (high)							

This is a “Read Only” status assembly.

Instance 180 Hardware Inputs 1-6								
Byte	Bit 7	Bit 6	Bit 5	Bit 4	Bit 3	Bit 2	Bit 1	Bit 0
0	Input 8	Input 7	Input 6	Input 5	Input 4	Input 3	Input 2	Input 1
1								

This is a “Read Only” status assembly.

Instance 184 Produced Network Outputs 1-15								
Byte	Bit 7	Bit 6	Bit 5	Bit 4	Bit 3	Bit 2	Bit 1	Bit 0
0	Net Out 8	Net Out 7	Net Out 6	Net Out 5	Net Out 4	Net Out 3	Net Out 2	Net Out 1
1	Net Out 16	Net Out 15	Net Out 14	Net Out 13	Net Out 12	Net Out 11	Net Out 10	Net Out 9

This is a “Read Only” status assembly.

Instance 185 Trip Status 1

Byte	Bit 7	Bit 6	Bit 5	Bit 4	Bit 3	Bit 2	Bit 1	Bit 0
0	GF Res	PTC	RTD Wind	Short Ckt	Cur Imbal	Jam	Undercurrent	Overload
1	GFCB	Sp Switch	P Factor	Ph Rev	Over V	Under V	Under power	VAR

This is a “Read Only” status assembly.

Instance 186 Trip Status 2

Byte	Bit 7	Bit 6	Bit 5	Bit 4	Bit 3	Bit 2	Bit 1	Bit 0
0	MCM err	RTD err	PTC err	RTD Amb	RTD other	Freq 2	Freq 1	Stall
1						Remote	Comm Idle	Comm Loss

This is a “Read Only” status assembly.

Instance 187 Warning Status 1

Byte	Bit 7	Bit 6	Bit 5	Bit 4	Bit 3	Bit 2	Bit 1	Bit 0
0	GF Res	PTC	RTD Wind	Short Ckt	Cur Imbal	Jam	Undercurrent	Overload
1	GFCB	Sp Switch	P Factor	Ph Rev	Over V	Under V	Under power	VAR

This is a “Read Only” status assembly.

Instance 188 Warning Status 2

Byte	Bit 7	Bit 6	Bit 5	Bit 4	Bit 3	Bit 2	Bit 1	Bit 0
0	MCM err	RTD err	PTC err	RTD Amb	RTD other	Freq 2	Freq 1	Stall
1						Remote	Comm Idle	Comm Loss

This is a “Read Only” status assembly.

Instance 189 Module Status

Byte	Bit 7	Bit 6	Bit 5	Bit 4	Bit 3	Bit 2	Bit 1	Bit 0
0				I/O Idle	I/O Flt	Exp Flt	I/O Cnxn	Exp Cnxn
1							Warning	Trip

Standard Output (Consumed) Assemblies

Instance 2 is the required output (consumed) assembly defined in the Motor Overload Profile.

Instance 3 ODVA Overload								
Byte	Bit 7	Bit 6	Bit 5	Bit 4	Bit 3	Bit 2	Bit 1	Bit 0
0						Flt Reset		

Instance 150 is the standard output (consumed) assembly with Network Inputs.

Instance 150 Standard Consumed Starter								
Byte	Bit 7	Bit 6	Bit 5	Bit 4	Bit 3	Bit 2	Bit 1	Bit 0
0	Aux 8	Aux 7	Aux 6	Aux 5	Aux 4	Aux 3	Aux 2	Aux 1
1	Flt Reset						Aux 10	Aux 9

Instance 151 is the standard output (consumed) assembly with Network Inputs.

Instance 151 Standard Consumed Starter with Network Inputs								
Byte	Bit 7	Bit 6	Bit 5	Bit 4	Bit 3	Bit 2	Bit 1	Bit 0
0	Aux 8	Aux 7	Aux 6	Aux 5	Aux 4	Aux 3	Aux 2	Aux 1
1	Flt Reset						Aux 10	Aux 9
2	Net In 8	Net In 7	Net In 6	Net In 5	Net In 4	Net In 3	Net In 2	Net In 1
3	Net In 16	Net In 15	Net In 14	Net In 13	Net In 12	Net In 11	Net In 10	Net In 9
4	Net In 24	Net In 23	Net In 22	Net In 21	Net In 20	Net In 19	Net In 18	Net In 17
5	Net In 32	Net In 31	Net In 30	Net In 29	Net In 28	Net In 27	Net In 26	Net In 25

This is a “Read/Write” control assembly.

Instance 181 Hardware Outputs 1-6								
Byte	Bit 7	Bit 6	Bit 5	Bit 4	Bit 3	Bit 2	Bit 1	Bit 0
0	Aux 8	Aux 7	Aux 6	Aux 5	Aux 4	Aux 3	Aux 2	Aux 1
1	Flt Reset						Aux 10	Aux 9

This is a “Read/Write” control assembly.

Instance 182 Consumed Network Inputs 1-16								
Byte	Bit 7	Bit 6	Bit 5	Bit 4	Bit 3	Bit 2	Bit 1	Bit 0
0	Net Input 8	Net Input 7	Net Input 6	Net Input 5	Net Input 4	Net Input 3	Net Input 2	Net Input 1
1	Net Input 16	Net Input 15	Net Input 14	Net Input 13	Net Input 12	Net Input 11	Net Input 10	Net Input 9

This is a “Read/Write” control assembly.

Instance 183 Consumed Network Inputs 17-32								
Byte	Bit 7	Bit 6	Bit 5	Bit 4	Bit 3	Bit 2	Bit 1	Bit 0
0	Net Input 24	Net Input 23	Net Input 22	Net Input 21	Net Input 20	Net Input 19	Net Input 18	Net Input 17
1	Net Input 32	Net Input 31	Net Input 30	Net Input 29	Net Input 28	Net Input 27	Net Input 26	Net Input 25

Connection Object - CLASS CODE 0x0005

No class attributes are supported for the Connection Object. Multiple instances of the Connection Object are supported, Instances 1, 2 and 4 from the group 2 predefined master/slave connection set, and Instances 5...7 are available explicit UCMM connections.

Instance 1 is the Predefined Group 2 Connection Set Explicit Message Connection. The following Instance 1 attributes are supported:

Attribute ID	Access Rule	Name	Data Type	Value
1	Get	State	USINT	0 = nonexistent 1 = configuring 3 = established 4 = timed out
2	Get	Instance Type	USINT	0 = Explicit Message
3	Get	Transport Class Trigger	USINT	0x83 - Server, Transport Class 3
4	Get	Produced Connection ID	UINT	10xxxxxx011 xxxxxx = node address
5	Get	Consumed Connection ID	UINT	10xxxxxx100 xxxxxx = node address
6	Get	Initial Comm Characteristics	USINT	0x22
7	Get	Produced Connection Size	UINT	0x61
8	Get	Consumed Connection Size	UINT	0x61
9	Get/Set	Expected Packet Rate	UINT	in milliseconds
12	Get	Watchdog Action	USINT	01 = auto delete 03 = deferred delete
13	Get	Produced Connection Path Length	UINT	0

Attribute ID	Access Rule	Name	Data Type	Value
14	Get	Produced Connection Path		Empty
15	Get	Consumed Connection Path Length	UINT	0
16	Get	Consumed Connection Path		Empty

Instance 2 is the Predefined Group 2 Connection Set Polled IO Message Connection. The following Instance 2 attributes are supported:

Attribute ID	Access Rule	Name	Data Type	Value
1	Get	State	USINT	0 = nonexistant 1 = configuring 3 = established 4 = timed out
2	Get	Instance Type	USINT	1 = I/O Connection
3	Get	Transport Class Trigger	USINT	0x82 - Server, Transport Class 2 (If alloc_choice != polled and ack suppression is enabled then value = 0x80)
4	Get	Produced Connection ID	UINT	01111xxxxx xxxxxx = node address
5	Get	Consumed Connection ID	UINT	10xxxxxx101 xxxxxx = node address
6	Get	Initial Comm Characteristics	USINT	0x21
7	Get	Produced Connection Size	UINT	0 to 8
8	Get	Consumed Connection Size	UINT	0 to 8
9	Get/Set	Expected Packet Rate	UINT	in milliseconds
12	Get/Set	Watchdog Action	USINT	0 = transition to timed out 1 = auto delete 2 = auto reset
13	Get	Produced Connection Path Length	UINT	8
14	Get/Set	Produced Connection Path		21 04 00 25 (assy inst #) 00 30 03
15	Get	Consumed Connection Path Length	UINT	8
16	Get/Set	Consumed Connection Path		21 04 00 25 (assy inst #) 00 30 03

Instance 4 is the Predefined Group 2 Connection Set Change of State/Cyclic IO Message Connection. The following Instance 4 attributes are supported:

Attribute ID	Access Rule	Name	Data Type	Value
1	Get	State	USINT	0 = nonexistent 1 = configuring 3 = established 4 = timed out
2	Get	Instance Type	USINT	1 = I/O Connection
3	Get	Transport Class Trigger	USINT	0x00 (Cyclic, unacknowledged) 0x03 (Cyclic, acknowledged) 0x10 (COS, unacknowledged) 0x13 (COS, acknowledged)
4	Get	Produced Connection ID	UINT	01101xxxxx xxxxxx = node address
5	Get	Consumed Connection ID	UINT	10xxxxx101 xxxxxx = node address
6	Get	Initial Comm Characteristics	USINT	0x02 (acknowledged) 0x0F (unacknowledged)
7	Get	Produced Connection Size	UINT	0 to 8
8	Get	Consumed Connection Size	UINT	0 to 8
9	Get/Set	Expected Packet Rate	UINT	in milliseconds
12	Get	Watchdog Action	USINT	0 = transition to timed out 1 = auto delete 2 = auto reset
13	Get	Produced Connection Path Length	UINT	8
14	Get	Produced Connection Path		21 04 00 25 (assy inst #) 00 30 03
15	Get	Consumed Connection Path Length	UINT	8
16	Get/Set	Consumed Connection Path		21 04 00 25 (assy inst #) 00 30 03

Instances 5...7 are available group 3 explicit message connections that are allocated through the UCMM. The following attributes are supported:

Attribute ID	Access Rule	Name	Data Type	Value
1	Get	State	USINT	0 = nonexistent 1 = configuring 3 = established 4 = timed out
2	Get	Instance Type	USINT	0 = Explicit Message
3	Get	Transport Class Trigger	USINT	0x83 - Server, Transport Class 3
4	Get	Produced Connection ID	UINT	Depends on message group and Message ID
5	Get	Consumed Connection ID	UINT	Depends on message group and Message ID
6	Get	Initial Comm Characteristics	USINT	0x33 (Group 3)
7	Get	Produced Connection Size	UINT	0
8	Get	Consumed Connection Size	UINT	
9	Get/Set	Expected Packet Rate	UINT	in milliseconds
12	Get	Watchdog Action	USINT	01 = auto delete 03 = deferred delete
13	Get	Produced Connection Path Length	UINT	0
14	Get	Produced Connection Path		Empty
15	Get	Consumed Connection Path Length	UINT	0
16	Get	Consumed Connection Path		Empty

The following services are implemented for the Connection Object:

Service Code	Implemented for:		Service Name
	Class	Instance	
0x05	No	Yes	Reset
0x0E	No	Yes	Get_Attribute_Single
0x10	No	Yes	Set_Attribute_Single

Discreet Input Point Object - CLASS CODE 0x0008 The following class attributes are supported for the Discrete Input Point Object:

Attribute ID	Access Rule	Name	Data Type	Value
1	Get	Revision	UINT	2
2	Get	Max Instance	UINT	2, 5, or 8

Five Instances of the Discrete Input Point Object are supported. All instances contains the following attributes:

Attribute ID	Access Rule	Name	Data Type	Value
3	Get	Value	BOOL	0 = OFF, 1 = ON
115	Get/Set	Force Enable	BOOL	0 = Disable, 1 = Enable
116	Get/Set	Force Value	BOOL	0 = OFF, 1 = ON

The following services are implemented for the Discrete Input Point Object:

Service Code	Implemented for:		Service Name
	Class	Instance	
0x0E	Yes	Yes	Get_Attribute_Single
0x10	No	Yes	Set_Attribute_Single

Discreet Output Point Object - CLASS CODE 0x0009

The following class attributes are supported for the Discrete Output Point Object:

Attribute ID	Access Rule	Name	Data Type	Value
1	Get	Revision	UINT	1
2	Get	Max Instance	UINT	2, 6, or 10

Six Instances of the Discrete Output Point Object are supported. All instances contains the following attributes:

Attribute ID	Access Rule	Name	Data Type	Value
3	Get	Value	BOOL	0 = OFF, 1 = ON
115	Get/Set	Force Enable	BOOL	0 = Disable, 1 = Enable
116	Get/Set	Force Value	BOOL	0 = OFF, 1 = ON
117	Get/Set	Input Binding	STRUCT: USINT Array of USINT	Size of appendix I encoded path Appendix I encoded path NULL path means attribute 3 drives the output. Otherwise, this is a path to a bit in the Bit Table.

The following services are implemented for the Discrete Output Point Object:

Parameter Object - CLASS CODE 0x000F

The following class attributes are supported for the Parameter Object:

Attribute ID	Access Rule	Name	Data Type	Value
1	Get	Revision	UINT	
2	Get	Max Instance	UINT	
8	Get	Parameter Class Descriptor	WORD	
9	Get	Configuration Assembly Instance	UINT	0

There is a standard set of instances reserved (1...100) for 825-PDN DeviceNet Communication Card specific parameters. These instances are followed by the motor relay parameters.

Refer to AppendixB of the 825-P Modular Protection System User Manual (publication 825-UM004) for details of the individual motor relay parameter instances.

The following services are implemented for the Parameter Object:

Service Code	Implemented for:		Service Name
	Class	Instance	
0x0E	Yes	Yes	Get_Attribute_Single
0x10	No	Yes	Set_Attribute_Single
0x01	No	Yes	Get_Attributes_All

The following instance attributes are implemented for all parameter attributes:

Attribute ID	Access Rule	Name	Data Type	Value
1	Get/Set	Value	Specified in Descriptor	
2	Get	Link Path Size	USINT	
3	Get	Link Path	Array of: BYTE EPATH	
4	Get	Descriptor	WORD	
5	Get	Data Type	EPATH	
6	Get	Data Size	USINT	
7	Get	Parameter Name String	SHORT_STRING	
8	Get	Units String	SHORT_STRING	
9	Get	Help String	SHORT_STRING	
10	Get	Minimum Value	Specified in Descriptor	
11	Get	Maximum Value	Specified in Descriptor	
12	Get	Default Value	Specified in Descriptor	
13	Get	Scaling Multiplier	UINT	
14	Get	Scaling Divisor	UINT	
15	Get	Scaling Base	UINT	
16	Get	Scaling Offset	INT	
17	Get	Multiplier Link	UINT	
18	Get	Divisor Link	UINT	
19	Get	Base Link	UINT	
20	Get	Offset Link	UINT	
21	Get	Decimal Precision	USINT	

Parameter Object - CLASS CODE 0x0010

The following class attributes are supported for the Parameter Object:

Attribute ID	Access Rule	Name	Data Type	Value
1	Get	Revision	UINT	
2	Get	Max Instance	UINT	

The 825-PDN DeviceNet Communication Card serves modules serves up the following instances of the parameter group object:

- Instance 1 = Status Parameters
- Instance 2 = DeviceNet Parameters
- Instance 3 = User I/O Parameters

- Instance 4 = Misc.
- Instance 5 = DeviceLogix Parameters
- Instance 6-n = Motor Relay specific parameter groups

The following instance attributes are supported for all parameter group instances:

Attribute ID	Access Rule	Name	Data Type	Value
1	Get	Group Name String	SHORT_STRING	
2	Get	Number of Members	UINT	
3	Get	1 st Parameter	UINT	
4	Get	2 nd Parameter	UINT	
n	Get	N th Parameter	UINT	

The following common services are implemented for the Parameter Group Object:

Service Code	Implemented for:		Service Name
	Class	Instance	
0x0E	Yes	Yes	Get_Attribute_Single

Discrete Output Group Object - CLASS CODE 0x001E

No class attributes are supported for the Discrete Output Group Object. Supported instances of the Discrete Output Group Object are listed below.

Instance 1 contains the following attributes:

Attribute ID	Access Rule	Name	Data Type	Value
3	Get	Number of Instances	USINT	10
4	Get	Binding	Array of UINT	List of DOP instances
6	Get/Set	Command	BOOL	0 = idle and 1 = run
104	Get/Set	Network Status Override	BOOL	0 = No Override (go to safe state) 1 = Override (run local logic)
105	Get/Set	Comm Status Override	BOOL	0 = No Override (go to safe state) 1 = Override (run local logic)

Instance 2 contains the following attributes:

Attribute ID	Access Rule	Name	Data Type	Value
3	Get	Number of Instances	USINT	10
4	Get	Binding	Array of UINT	1, 2
7	Get/Set	Fault Action	BOOL	0=Fault Value attribute, 1=Hold Last State
8	Get/Set	Fault Value	BOOL	0=OFF, 1=ON
9	Get/Set	Idle Action	BOOL	0=Fault Value attribute, 1=Hold Last State
10	Get/Set	Idle Value	BOOL	0=OFF, 1=ON
113	Get/Set	Pr Fault Action	BOOL	0=Fault Value attribute, 1=Hold Last State
114	Get/Set	Pr Fault Value	BOOL	0=OFF, 1=ON

Instance 3 contains the following attributes:

Attribute ID	Access Rule	Name	Data Type	Value
3	Get	Number of Instances	USINT	4
4	Get	Binding	Array of UINT	3, 4, 5, 6
7	Get/Set	Fault Action	BOOL	0=Fault Value attribute, 1=Hold Last State
8	Get/Set	Fault Value	BOOL	0=OFF, 1=ON
9	Get/Set	Idle Action	BOOL	0=Fault Value attribute, 1=Hold Last State
10	Get/Set	Idle Value	BOOL	0=OFF, 1=ON
113	Get/Set	Pr Fault Action	BOOL	0=Fault Value attribute, 1=Hold Last State
114	Get/Set	Pr Fault Value	BOOL	0=OFF, 1=ON

Instance 4 contains the following attributes:

Attribute ID	Access Rule	Name	Data Type	Value
3	Get	Number of Instances	USINT	4
4	Get	Binding	Array of UINT	7, 8, 9, 10
7	Get/Set	Fault Action	BOOL	0=Fault Value attribute, 1=Hold Last State
8	Get/Set	Fault Value	BOOL	0=OFF, 1=ON
9	Get/Set	Idle Action	BOOL	0=Fault Value attribute, 1=Hold Last State
10	Get/Set	Idle Value	BOOL	0=OFF, 1=ON
113	Get/Set	Pr Fault Action	BOOL	0=Fault Value attribute, 1=Hold Last State
114	Get/Set	Pr Fault Value	BOOL	0=OFF, 1=ON

The following common services are implemented for the Discrete Input Group Object:

Service Code	Implemented for:		Service Name
	Class	Instance	
0x0E	No	Yes	Get_Attribute_Single
0x10	No	Yes	Set_Attribute_Single

Control Supervisor Object - CLASS CODE 0x0029

No class attributes are supported.

Only Instance 1 of the Control Supervisor Object is supported. The following instance attributes are supported:

Attribute ID	Access Rule	Name	Data Type	Value
10	Get	Tripped	BOOL	
11	Get	Warning	BOOL	
12	Get/Set	Fault Reset	BOOL	0->1 = Trip Reset

The following common services are implemented for the Control Supervisor Object:

Service Code	Implemented for:		Service Name
	Class	Instance	
0x0E	No	Yes	Get_Attribute_Single
0x10	No	Yes	Set_Attribute_Single

Acknowledge Handler Object - CLASS CODE 0x002b

No class attributes are supported for the Acknowledge Handler Object.

Only Instance 1 of the Acknowledge Handler Object is supported. The following instance attributes are supported:

Attribute ID	Access Rule	Name	Data Type	Value
1	Get/Set	Acknowledge Timer	UINT	milliseconds
2	Get	Retry Limit	USINT	1
3	Get	COS Producing Connection Instance	UINT	4

The following common services are implemented for the Acknowledge Handler Object:

Service Code	Implemented for:		Service Name
	Class	Instance	
0x0E	No	Yes	Get_Attribute_Single
0x10	No	Yes	Set_Attribute_Single

**Overload Object - CLASS
CODE 0x002c**

No class attributes are supported for the Overload Object. Only Instance 1 of the Overload Object is supported.

Attribute ID	Access Rule	Name	Data Type	Value
5	Get	Average Current	UINT	xxx.x amps
6	Get	%Phase Imbal	USINT	xxx% FLA
7	Get	% Thermal Utilized	USINT	xxx% FLA
8	Get	Current L1	UINT	xxx.x amps
9	Get	Current L2	UINT	xxx.x amps
10	Get	Current L3	UINT	xxx.x amps
11	Get	Ground Current	UINT	xxx.x amps

The following common services are implemented for the Overload Object:

Service Code	Implemented for:		Service Name
	Class	Instance	
0x0E	No	Yes	Get_Attribute_Single
0x10	No	No	Set_Attribute_Single

**DeviceNet Interface Object
- CLASS CODE 0x00B4**

The following class attributes are supported for the DeviceNet Interface Object:

Attribute ID	Access Rule	Name	Data Type	Value
1	Get	Revision	UINT	02

Only Instance 1 of the DeviceNet Interface Object is supported:

Attribute ID	Access Rule	Name	Data Type	Min/Max	Default	Description
7	Get/Set	Prod Assy Word 0	UINT		1	Defines Word 0 of Assy 100
8	Get/Set	Prod Assy Word 1	UINT		5	Defines Word 1 of Assy 100
9	Get/Set	Prod Assy Word 2	UINT		6	Defines Word 2 of Assy 100
10	Get/Set	Prod Assy Word 3	UINT		7	Defines Word 3 of Assy 100
15	Get/Set	Autobaud Enable	BOOL	0...1	1	1= enabled; 0 = disabled
16	Get/Set	Consumed Assy	USINT	0...185	150	
17	Get/Set	Produced Assy	USINT	0...185	103	
19	Get/Set	Set To Defaults	BOOL	0...1	0	0=No action; 1=Reset
23	Get	I/O Produced Size	USINT	0...16		Read only
24	Get	I/O Consumed Size	USINT	0...8		Read only
30	Get	DeviceNet Voltage	UINT			Read only
50	Get/Set	PNB COS Mask	WORD	0...0x00FF	0	Change of state mask for PNBs
55	Get/Set	Prod Assy Word 4	UINT		0	Defines Word 4 of Assy 100
56	Get/Set	Prod Assy Word 5	UINT		0	Defines Word 5 of Assy 100
57	Get/Set	Prod Assy Word 6	UINT		0	Defines Word 6 of Assy 100
58	Get/Set	Prod Assy Word 7	UINT		0	Defines Word 7 of Assy 100
65	Get/Set	Status COS Mask 1	UINT	0...ffff	0	
66	Get/Set	Status COS Mask 2	UINT	0...ffff	0	
67	Get/Set	Trip COS Mask 1	UINT	0...ffff	0	
68	Get/Set	Trip COS Mask 2	UINT	0...ffff	0	
69	Get/Set	Warning COS Mask 1	UINT	0...ffff	0	
70	Get/Set	Warning COS Mask 2	UINT	0...ffff	0	

The following common services are implemented for the DeviceNet Interface Object:

Service Code	Implemented for:		Service Name
	Class	Instance	
0x0E	No	Yes	Get_Attribute_Single
0x10	No	No	Set_Attribute_Single

Rockwell Automation Support

Rockwell Automation provides technical information on the Web to assist you in using its products.

At <http://www.rockwellautomation.com/support/>, you can find technical manuals, a knowledge base of FAQs, technical and application notes, sample code and links to software service packs, and a MySupport feature that you can customize to make the best use of these tools.

For an additional level of technical phone support for installation, configuration, and troubleshooting, we offer TechConnect support programs. For more information, contact your local distributor or Rockwell Automation representative, or visit <http://www.rockwellautomation.com/support/>.

Installation Assistance

If you experience a problem within the first 24 hours of installation, review the information that is contained in this manual. You can contact Customer Support for initial help in getting your product up and running.

United States or Canada	1.440.646.3434
Outside United States or Canada	Use the Worldwide Locator at http://www.rockwellautomation.com/support/americas/phone_en.html , or contact your local Rockwell Automation representative.

New Product Satisfaction Return

Rockwell Automation tests all of its products to ensure that they are fully operational when shipped from the manufacturing facility. However, if your product is not functioning and needs to be returned, follow these procedures.

United States	Contact your distributor. You must provide a Customer Support case number (call the phone number above to obtain one) to your distributor to complete the return process.
Outside United States	Please contact your local Rockwell Automation representative for the return procedure.

Documentation Feedback

Your comments will help us serve your documentation needs better. If you have any suggestions on how to improve this document, complete this form, publication [RA-DU002](#), available at <http://www.rockwellautomation.com/literature/>.

Rockwell Otomasyon Ticaret A.Ş., Kar Plaza İş Merkezi E Blok Kat:6 34752 İçerenköy, İstanbul, Tel: +90 (216) 5698400

www.rockwellautomation.com

Power, Control and Information Solutions Headquarters

Americas: Rockwell Automation, 1201 South Second Street, Milwaukee, WI 53204-2496 USA, Tel: (1) 414.382.2000, Fax: (1) 414.382.4444

Europe/Middle East/Africa: Rockwell Automation NV, Pegasus Park, De Kleetlaan 12a, 1831 Diegem, Belgium, Tel: (32) 2 663 0600, Fax: (32) 2 663 0640

Asia Pacific: Rockwell Automation, Level 14, Core F, Cyberport 3, 100 Cyberport Road, Hong Kong, Tel: (852) 2887 4788, Fax: (852) 2508 1846