

Allen-Bradley

DeviceNet Starter Kit

1787-GEN2SKIT, -2, -3, -4, -5, -6, -7

User Manual

**Rockwell
Automation**

Important User Information

Because of the variety of uses for the products described in this publication, those responsible for the application and use of this control equipment must satisfy themselves that all necessary steps have been taken to assure that each application and use meets all performance and safety requirements, including any applicable laws, regulations, codes and standards.

The illustrations, charts, sample programs and layout examples shown in this guide are intended solely for purposes of example. Since there are many variables and requirements associated with any particular installation, Allen-Bradley does not assume responsibility or liability (to include intellectual property liability) for actual use based upon the examples shown in this publication.

Allen-Bradley publication SGI-1.1, *Safety Guidelines for the Application, Installation and Maintenance of Solid-State Control* (available from your local Allen-Bradley office), describes some important differences between solid-state equipment and electromechanical devices that should be taken into consideration when applying products such as those described in this publication.

Reproduction of the contents of this copyrighted publication, in whole or part, without written permission of Rockwell Automation, is prohibited.

Throughout this manual we use notes to make you aware of safety considerations:

ATTENTION



Identifies information about practices or circumstances that can lead to personal injury or death, property damage or economic loss

Attention statements help you to:

- identify a hazard
- avoid a hazard
- recognize the consequences

IMPORTANT

Identifies information that is critical for successful application and understanding of the product.

European Communities (EC) Directive Compliance

If this product has the CE mark it is approved for installation within the European Union and EEA regions. It has been designed and tested to meet the following directives.

EMC Directive

This product is tested to meet the Council Directive 89/336/EC Electromagnetic Compatibility (EMC) by applying the following standards, in whole or in part, documented in a technical construction file:

- EN 50081-2 EMC — Generic Emission Standard, Part 2 — Industrial Environment
- EN 50082-2 EMC — Generic Immunity Standard, Part 2 — Industrial Environment

This product is intended for use in an industrial environment.

Low Voltage Directive

This product is tested to meet Council Directive 73/23/EEC Low Voltage, by applying the safety requirements of EN 61131-2 Programmable Controllers, Part 2 - Equipment Requirements and Tests. For specific information required by EN 61131-2, see the appropriate sections in this publication, as well as the Allen-Bradley publication Industrial Automation Wiring and Grounding Guidelines For Noise Immunity, publication 1770-4.1.

This equipment is classified as open equipment and must be mounted in an enclosure during operation to provide safety protection.

In This Manual

The following chapters describe how to set up a simple DeviceNet network and perform basic operations with RSNetWorx for DeviceNet:

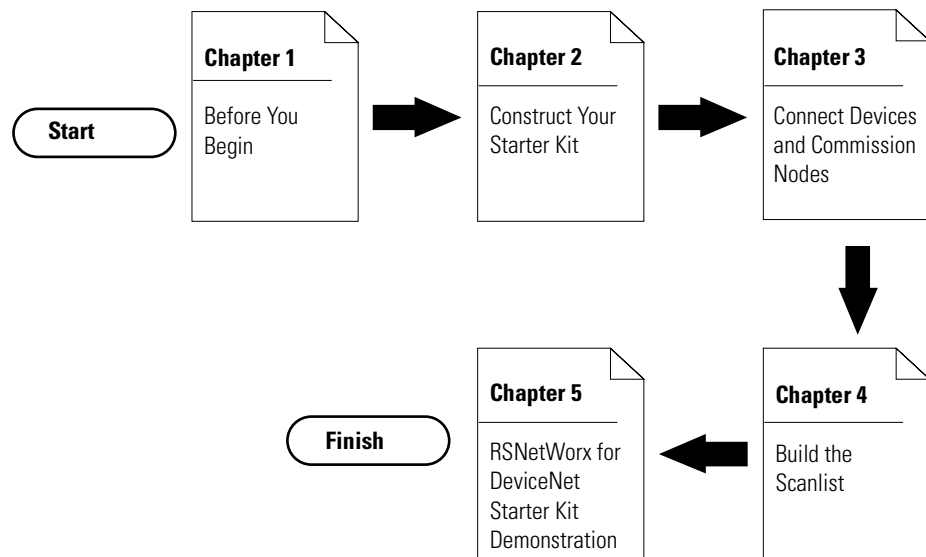

42032

Conventions

We use the following conventions:

- Bulleted lists provide information, not procedural steps.
- Numbered lists provide sequential steps.
- Pictures of keys and/or screens represent the actual keys you press or the screens you use.

Your Questions or Comments About This Manual

If you find a problem with this manual, please notify us of it on the enclosed Publication Problem Report (at the back of this manual).

If you have any suggestions about how we can make this manual more useful to you, please contact us at the following address, or complete the Publication Problem Report at the end of this manual:

Marketing Communications
Rockwell Automation
1 Allen-Bradley Drive
Mayfield Heights, OH 44124-6118

fax: (440) 646-3525

Preface	In This Manual	5
	Conventions	5
	Your Questions or Comments About This Manual	6
	Chapter 1	
Before You Begin	What This Chapter Contains	1-1
	What is DeviceNet?	1-1
	Set up Your Starter Kit.	1-2
	The Hardware and Software You Need for Your Starter Kit.	1-3
	What You Must Know and Have Done	1-6
	Identify the StarterKit Components.	1-6
	Rockwell Automation Support	1-10
	Obtain Pre-Sales Product Support.	1-10
	Obtain Technical Product Support	1-10
	Related Publications	1-11
	Summary and What's Next.	1-12
	Chapter 2	
Construct Your Starter Kit	What This Chapter Contains	2-1
	What Your Network Will Look Like	2-1
	SKITS 1, 3, and 5	2-2
	SKITS 2, 4, and 6	2-3
	SKIT 7	
	Assemble the KwikLink Media System	2-4
	Install the ArmorBlock MaXum Base	2-9
	Mount the Cable Base	2-9
	Prepare the Flat Media Cables	2-9
	Attach the Flat Media Cables	2-11
	Attach the Seal Block	2-12
	Connect Your Power Supply	2-14
	Ground Your Network	2-15
	Set up the 1771-SDN Scanner for SKITs 3 and 4	2-15
	Set Node Address Switches for Channel 1	2-16
	Install Your Scanner	2-16
	Connect the 1770-KFD for SKITs 1, 3, and 5.	2-17
	Install the 1784-PCD for SKITs 2, 4, and 6	2-19
	Connect the 1784-PCD to Your Network for	
	SKITs 2, 4, and 6	2-20
	Remove the 1784-PCD Card	2-22
	Set up the 1784-PCIDS for SKIT7	2-23
	Install the 1784-PCIDS Card	2-23
	Install the 1784-PCIDS Drivers	2-25
	Connect to the Network.	2-26
	Install RSNetWorx for DeviceNet and RSLinx	2-27
	Follow these instructions:.	2-27
	Summary and What's Next.	2-29

	Chapter 3		
Connect Devices and Commission Nodes	What This Chapter Contains	3-1	
	What is Node Commissioning?	3-1	
	RSNetWorx for DeviceNet Node Commission Tool	3-2	
	RSNetWorx Communicates via RSLinx.	3-3	
	Device Configuration	3-3	
	Electronic Data Sheets (EDS)	3-3	
	Prepare to Add Nodes	3-4	
	Set up Your Network	3-5	
	Configure Drivers	3-6	
	Commission Nodes	3-13	
	Commission the ArmorBlock MaXum I/O Module	3-14	
	Connect and Commission the CompactBlock I/O Module	3-17	
	Connect and Commission the ControlTower Stack Light.	3-24	
	Connect and Commission the Inductive Proximity Switch	3-26	
	Connect and Commission the RightSight Photoelectric Sensor.	3-30	
	What Your Network Will Look Like in RSNetWorx	3-35	
	If You Use the Provided .dnt File	3-39	
	Edit the Properties (not required)	3-40	
		Chapter 4	
	Build the Scanlist	What This Chapter Contains	4-1
Introduction		4-1	
What is a Scanlist?		4-2	
Configure Your Scanner		4-3	
If You Want to Use the Pre-mapped .dnt File		4-3	
If You Want to Use the .dnt File You Created in Chapter 3		4-6	
Edit I/O Parameters for the Inductive Proximity Switch		4-13	
Map Input Devices.		4-17	
Map Output Devices		4-22	

	Chapter 5	
RSNetWorx for DeviceNet Starter Kit Demonstration	What This Chapter Contains	5-1
	What Does the DeviceNet Starter Kit Demonstration Do? . .	5-1
	Files to Use With Your Starter Kit	5-2
	Run the Demonstration	5-3
	Ladder Logic for SKITs 1 and 2	5-4
	Ladder Logic for SKITs 3 and 4	5-5
	Ladder Logic for SKITs 5 and 6	5-6
	Ladder Logic for SKIT 7.	5-7
Monitor the I/O Data	5-8	
	Appendix A	
Numeric Code Display Summary		
	Index	

Notes:

Before You Begin

What This Chapter Contains This chapter describes what you must know and do before you begin to use your Starter Kit. The following table describes what this chapter contains and where to find specific information.

For information about:	See page:
DeviceNet	1-1
the hardware and software you need for your Starter Kit	1-3
what you need to know and do before you use your Starter Kit	1-6
the Starter Kit components	1-6
the set-up of your Starter Kit	1-2
Rockwell Automation support	1-10
related publications	1-11

What is DeviceNet?

DeviceNet is a low-end, open network that provides connections between simple, primarily discrete industrial devices and controllers. The connections can exist without the need of intervening I/O modules or blocks.

The DeviceNet network provides an alternative way for control engineers to connect simple devices to their control systems. The DeviceNet network:

- supports devices that are becoming more intelligent
- facilitates increasingly precise troubleshooting that reduces down-time, for example, a communication fault can be traced to a single device rather than to the rack or block level as with an I/O network
- reduces installation and startup costs and time (compared to traditional I/O wiring, especially when devices are spread over long distances)

Set up Your Starter Kit

The following table lists the steps you need to take to get your Starter Kit constructed and operating properly. Copy the list and use it as a reference or checklist to help you keep track of your work. Refer to Chapters 2, 3, 4, and 5 for detailed instructions.

Table 1.A Follow these steps to set up your Starter Kit

Chapter 1

Chapter 2

Chapter 3

Check	Steps to follow:
<input type="checkbox"/>	1. Organize your Starter Kit contents.
<input type="checkbox"/>	2. Assemble the KwikLink Media System.
<input type="checkbox"/>	3. Attach the flat media cables to the Armor MaXum base and attach the seal block.
<input type="checkbox"/>	4. Connect your 24V dc power supply and properly ground the network.
<input type="checkbox"/>	5. Connect your PC to the controller interface. <ul style="list-style-type: none"> a. 1770-KFD (SKITs 1, 3, & 5) b. 1784-PCD (SKITs 2, 4, & 6) c. 1784-PCIDS (SKIT 7)
<input type="checkbox"/>	6. Connect the controller interface to scanner. <ul style="list-style-type: none"> a. 1770-KFD (SKITs 1, 3, 5) b. 1784-PCD (SKITs 2, 4, 6) c. 1784-PCIDS (SKIT 7)
<input type="checkbox"/>	7. Install the demo version of RSNetWorx for DeviceNet.
<input type="checkbox"/>	8. Start RSLinx.
<input type="checkbox"/>	9. Select the DeviceNet Driver for your controller interface.
<input type="checkbox"/>	10. Go online and browse your network.
<input type="checkbox"/>	11. Minimize RSLinx.
<input type="checkbox"/>	12. Start RSNetworx and browse your DeviceNet network.
<input type="checkbox"/>	13. Node Commission. <ul style="list-style-type: none"> a. Set node address on the ArmorBlock MaXum to 01. b. Attach the module to the base. c. Connect the Standard Proximity Switch to the ArmorBlock Maxum. d. Browse your network.

Table 1.A Follow these steps to set up your Starter Kit

Check	Steps to follow:
<input type="checkbox"/>	14. Connect and node commission one device at a time. <ol style="list-style-type: none"> CompactBlock I/O ControlTower Stack Light Inductive Proximity Switch RightSight Photoelectric Sensor
<input type="checkbox"/>	15. Automap a scanlist, modify the scanlist and download the configuration to the scanner or use the .dnt file provided with your Starter Kit.
<input type="checkbox"/>	16. Edit the I/O Parameters for the Inductive Proximity Switch to send a strobed signal vs. a cyclic signal.
<input type="checkbox"/>	17. Start RSLogix 5, 500, 5000 or other ladder logic software.
<input type="checkbox"/>	18. Open the provided demonstration ladder logic, go online and download the program to the processor.
<input type="checkbox"/>	19. Experiment with your network.

Chapter 4**Chapter 5**

The Hardware and Software You Need for Your Starter Kit

The following tables list the materials you need in order to follow the procedures described in this manual.

Become familiar with which products come with the DeviceNet Starter Kits and which you must provide. A set of “base” products are provided for use with your DeviceNet Starter Kit. The following products are common to all seven SKITs:

Base products provided in the SKITs:	Catalog Number:
<i>DEMO VERSION</i> , RSNetWorx™ for DeviceNet	9357-DNET-L3
RightSight Photoelectric Sensor	42EF-D1LDAK-F5
DeviceNet Inductive Proximity Switch	871TM-D5ED18-D5
CompactBlock I/O (8 In / 8 Out)	1791D-8B8P
ArmorBlock MaXum (4 In / 4 Out)	1792D-4BVT4D
ArmorBlock MaXum Base for Flat Media	1792D-CBFM
DeviceNet ControlTower Stack Light Base	855T-DM1BSB
Stack Light green	855T-B24DN3
Stack Light red	855T-B24DN4
Standard Proximity Switch	872C-D3NP8-D4
Termination Resistor for Flat Media (2)	1485A-T1H4
Probe Cable	1787-PCABL
Cable, micro 90 to conductor (2)	1485K-P1F5C
Sensor cable, works with ArmorBlock MaXum I/O	889D-F4ACDM-1
Cable, micro male to micro female (2)	1485K-P1F5-R5

Base products provided in the SKITS:	Catalog Number:
KwikLink tap (IDC), open-style for power (1)	1485P-P1H4-T4
KwikLink tap (IDC), micro quick-disconnect (5)	1485P-P1H4-R5
Application disk	n/a
Gym bag	n/a
Pocket knife	n/a
Screw driver	n/a

IMPORTANT

The Starter Kit catalog numbers are 1787-GEN2KIT1, 2, 3, 4, 5, 6, and 7. For simplicity, we are referring to the Starter Kits in this manual as SKIT1 through SKIT7.

SKIT1 also contains:

DeviceNet Scanner for SLC	1	1747-SDN ¹
DeviceNet Serial Interface	1	1770-KFD

SKIT1 is the configuration that we use throughout this manual.

SKIT2 also contains:

DeviceNet Scanner for SLC	1	1747-SDN ¹
DeviceNet PCMCIA Interface	1	1784-PCD

SKIT3 also contains:

DeviceNet Scanner for PLC-5	1	1771-SDN ²
DeviceNet Serial Interface	1	1770-KFD

SKIT4 also contains:

DeviceNet Scanner for PLC-5	1	1771-SDN ²
DeviceNet PCMCIA Interface	1	1784-PCD

SKIT5 also contains:

DeviceNet Scanner for ControlLogix	1	1756-DNB ³
DeviceNet Serial Interface	1	1770-KFD

SKIT6 also contains:

DeviceNet Scanner for ControlLogix	1	1756-DNB
DeviceNet PCMCIA Interface	1	1784-PCD

SKIT7 also contains:

DeviceNet PCI bus interface/scanner ControlPak CD-ROM	1	1784-PCIDS ⁴
--	---	-------------------------

¹ The 1747-SDN works with an SLC™ 5/02, 5/03, 5/04, or 5/05 processor.

² The 1771-SDN works with the PLC-5® family processors.

³ The 1756-DNB works with ControlLogix 5550 processors.

⁴ The 1784-PCIDS works with PC based control systems such as SoftLogix 5.

You Must Provide:

- 1. PLC®, SLC 5/02, 5/03, 5/04, 5/05 or ControlLogix processor and software
- 2. PLC, SLC or ControlLogix chassis power supply
- 3. PLC, SLC or ControlLogix interface module (for PLC programming)
- 4. 24V dc power supply (minimum 3A) that meets DeviceNet specifications. Refer to the DeviceNet power supply specifications in publication, DN-6.7.2, DeviceNet Cable System Planning and Installation Manual.
- 5. IBM® compatible PC with Microsoft® Windows® 95/98 or Windows NT (NT required for PCIDS) operating system
- 6. PC-to-SLC, PLC, or ControlLogix processor¹

¹ Due to the varied possibilities, the components for your PC-to-processor communication link do not appear in this table or the following illustrations. Your existing PC-to-processor connection is compatible with this document's procedures and configurations.

IMPORTANT

All SKITs are identical except for the scanner and/or PC interface card used. This manual shows examples using SKIT1 (w/SLC and 1747-SDN). Differences are based on PLC processor technology (scanner mapping and PLC processor programming). These variations are described where applicable in this manual.

What You Must Know and Have Done

The descriptions in this user manual assume that you know how to install and use all of the hardware and software that you must provide (listed above). If you do not, read the documentation associated with these items for guidance.

Identify the Starter Kit Components

Unpack your Starter Kit and use the following illustrations to identify all of the components shipped. Contact your local Rockwell Automation representative if an item is missing

- Probe cable
Cat. no. 1787-PCABL

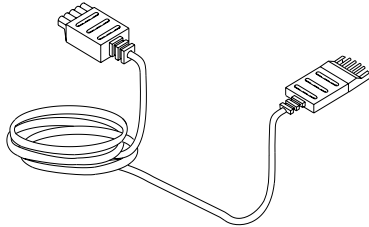

- Serial cable for use with 1770-KFD in SKITs 1, 3 and 5
P/N 96881501

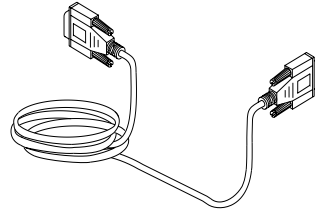

- KwikLink tap (IDC), micro quick-disconnect (5)
Cat. no. 1485P-P1H4-R5

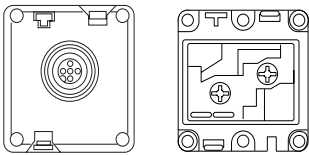

- Cable micro 90 to conductor (2)
Cat. no. 1485K-P1F5C

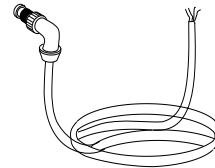

- KwikLink tap (IDC), open-style (1)
Cat. no. 1485P-P1H4-T4

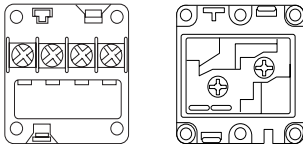

- Cable micro male to micro female (2)
Cat. no. 1485K-P1F5-R5

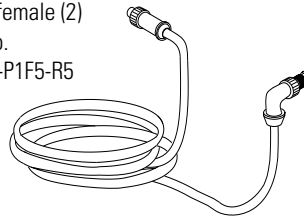

- KwikLink termination resistor (2)
Cat. no. 1485A-T1H4

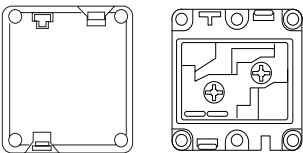

- Sensor cable for use with Standard Proximity Switch and ArmorBlock MaXum I/O Cat. no. 889D-F4ACD-M1

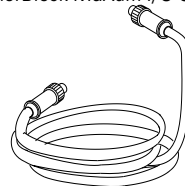

- KwikLink trunk cable (1m)

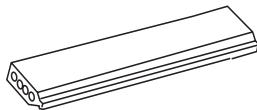

- Screw driver



- Gym bag

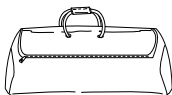

- Knife

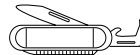

42022

SKIT1: 1747-SDN and 1770-KFD

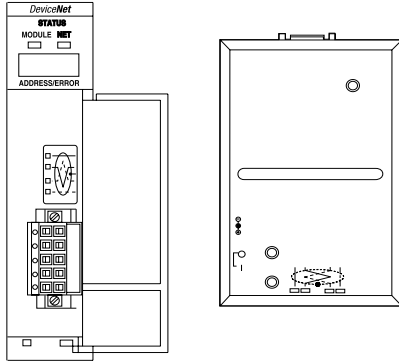

SKIT2: 1747-SDN and 1784-PCD

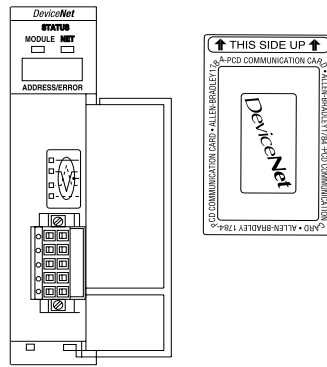

SKIT3: 1771-SDN and 1770-KFD

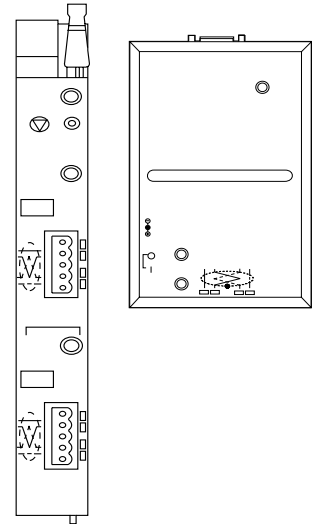

SKIT4: 1771-SDN and 1784-PCD

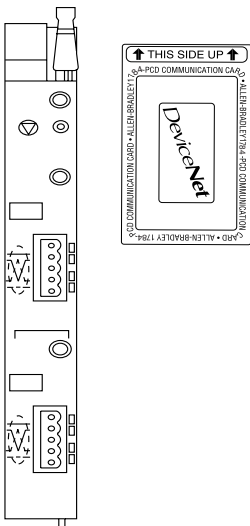

SKIT5: 1756-DNB and 1770-KFD

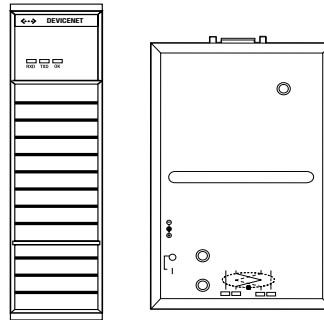

SKIT6: 1756-DNB and 1784-PCD

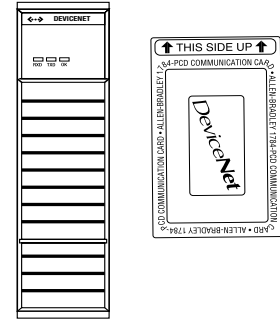

SKIT7: 1784-PCIDS with CDROM

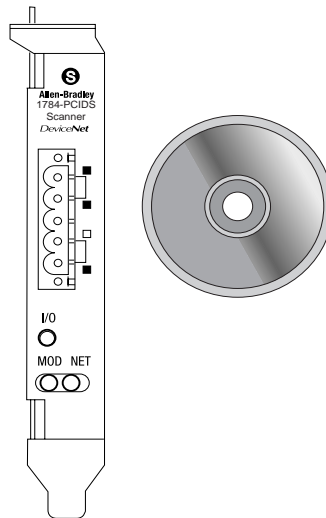

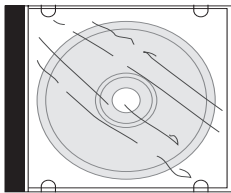

Serial #: 0123456789
(any 10 digit number)

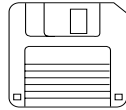

DEMO VERSION, RSNetWorx for DeviceNet Cat. no. 9357-DNET-L3

Floppy disk containing files for demonstration

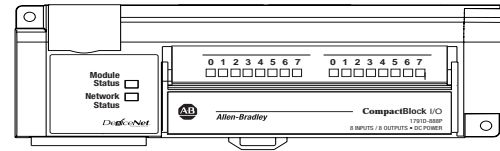

CompactBlock I/O (8 IN / 8 Out) Cat. no. 1791D-8B8P

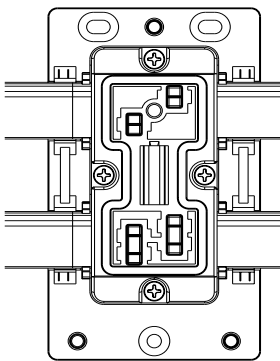

MaXum Base for flat media Cat. no. 1792D-CBFM

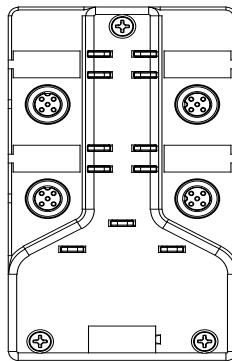

ArmorBlock MaXum I/O (4 In / 4 Out)

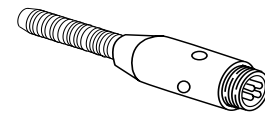

Standard Proximity Switch for use with ArmorBlock MaXum I/O Cat. no. 872C-D3NP8-D4

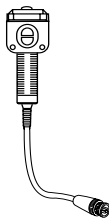

RightSight Photoelectric Sensor Cat. no. 42EF-D1LDAK-F5

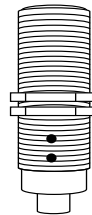

DeviceNet Inductive Proximity Switch Cat. no. 871TM-D5ED18-D5

Stack Light, red Cat. no. 855T-B24DN4



Stack Light, green Cat. no. 855T-B24DN3



DeviceNet ControlTower Stack Light base and cap Cat. no. 855T-DM1BSB

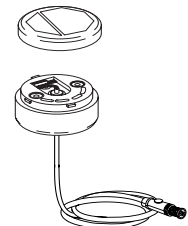

DeviceNet Cable Planning and Installation Guide Pub. no. DN-6.7.2



DeviceNet Starter Kit Pub. no. DN-6.5.16



41990

Rockwell Automation Support

Rockwell Automation offers support services worldwide, with over 75 sales/support offices, over 500 authorized distributors, and 260 authorized systems integrators located throughout the United States alone, plus Rockwell Automation representatives in every major country around the world.

Contact your local Rockwell Automation representative for:

- sales and order support
- product technical training
- warranty support
- support service agreements

Obtain Pre-Sales Product Support

If you need to contact Rockwell Automation for pre-sales product support, try one of the following methods:

- Call your local Rockwell Automation representative
- Network Pre-sales support line, 1.440.646.3638 (3NET)
- Pre-Sales e-mail, RACle3net@ra.rockwell.com

Obtain Technical Product Support

If you need to contact Rockwell Automation for technical assistance, try one of the following methods:

- Call your local Rockwell Automation representative
- DeviceNet Post-Sales Technical Support, 1.440.646.5800
- Fax Back system, 1.440.646.5436 (requires a touch-tone telephone)
- Web Links: <http://www.ab.com> as a registered member, open to <http://www.ab.com/mem/technotes/techmain.html>
- Electronic Data Sheets: <http://www.ab.com/networks/eds/index.html>
- RSNetWorx and RSLinx Software Demos and Tutorials

Related Publications

The following table is a list of reference publications for the DeviceNet network. You can access these publications on the web at www.theautomationbookstore.com.

For information about how to:	Catalog Number:	Publication Name:	Publication Number:
plan and install a DeviceNet cable system	DNET	DeviceNet Cable System Planning and Installation Manual	DN-6.7.2
select DeviceNet products	DNET	DeviceNet Product Selection Guide	DNET-S000IA-EN
design DeviceNet systems	DNET	DeviceNet System Design Guide	DNET-AT001A-EN
configure the 1771-SDN scanner	1771-SDN	DeviceNet Scanner Configuration Manual (1771-SDN)	1771-6.5.118
configure the 1747-SDN scanner	1747-SDN	DeviceNet Scanner Configuration Manual (1747-SDN)	1747-6.5.2
configure the 1784-PCIDS scanner	1784-PCIDS	DeviceNet Scanner Configuration Manual (1784-PCIDS)	1784-6.5.28
install the 1784-PCIDS scanner	1784-PCIDS	DeviceNet PCI Communication Interface Card Installation Instructions	1784-5.31
configure the 1756-DNB scanner	1756-DNB	DeviceNet Scanner Installation Instructions (1756-DNB) DeviceNet Scanner User Manual (1756-DNB)	1756-5.66 1756-6.5.19
configure the 1784-PCD interface card	1784-PCD Series A and B	DeviceNet PC Card Installation Instructions	1784-5.29
use RSNetWorx™ for DeviceNet	9357-DNET-L3	Refer to the RSNetWorx™ online manual located in the Help Menu	N/A
configure the CompactBlock I/O (8 In / 8 Out)	1791D-8B8P	CompactBlock I/O for DeviceNet Modules Installation Instructions	1791D-5.42
install the ArmorBlock MaXum (4 In / 4 Out)	1792D-4BVT4D	ArmorBlock MaXum 4 Input/4 Output Module Installation Instructions	1792D-5.12
install the ArmorBlock MaXum Base for flat media	1792D-CBFM	ArmorBlock MaXum I/O Cable Bases Installation Instructions	1792-5.9
use and install the termination resistors for flat media	1485A-T1H4	DeviceNet Cable System Planning and Installation Manual	DN-6.7.2
use the probe cables	1787-PCABL	DeviceNet Cable System Planning and Installation Manual	DN-6.7.2
use the micro 90 to conductor cables	1485K-P1F5C	DeviceNet Cable System Planning and Installation Manual	DN-6.7.2
use the sensor cable	889D-F4ACDM-1	DeviceNet Cable System Planning and Installation Manual	DN-6.7.2
use the micro male to micro female cables	1485K-P1F5-R5	DeviceNet Cable System Planning and Installation Manual	DN-6.7.2
use and install the KwikLink (IDC) taps, open-style for power	1485P-P1H4-T4	DeviceNet Cable System Planning and Installation Manual	DN-6.7.2
use and install the KwikLink (IDC) tap, micro quick-disconnect	1485P-P1H4-R5	DeviceNet Cable System Planning and Installation Manual	DN-6.7.2

Summary and What's Next

In this chapter, we described:

- the DeviceNet network
- what you need to use this Starter Kit
- how to identify the Starter Kit components
- the steps you need to take to get your kit constructed and operating properly
- Rockwell Automation support services

Move on to Chapter 2 to:

- construct your network
- install the ArmorBlock MaXum base and seal block
- connect your power supply
- ground your network
- connect your scanner and interface
- install RSNetWorx for DeviceNet software

Construct Your Starter Kit

What This Chapter Contains

Read this chapter to construct your Starter Kit, connect the scanner and interface, install software, and properly ground the network before setting up an online connection with your PC. The following table describes what this chapter contains and where to find specific information.

To:	See page:
identify what your network will look like	2-1
assemble the KwikLink media system	2-4
install the ArmorBlock MaXum I/O	2-9
connect your power supply	2-14
ground your network	2-15
set up the 1771-SDN for SKITs 3 and 4	2-15
connect the 1770-KFD for SKITs 1, 3, and 5	2-17
install the 1784-PCD for SKITs 2, 4, and 6	2-19
set up the 1784-PCIDS for SKIT7	2-23
install the <i>DEMO</i> version of RSNetWorx	2-27

What Your Network Will Look Like

Refer to the illustrations below when you connect the devices your DeviceNet network.

SKITS 1, 3, and 5

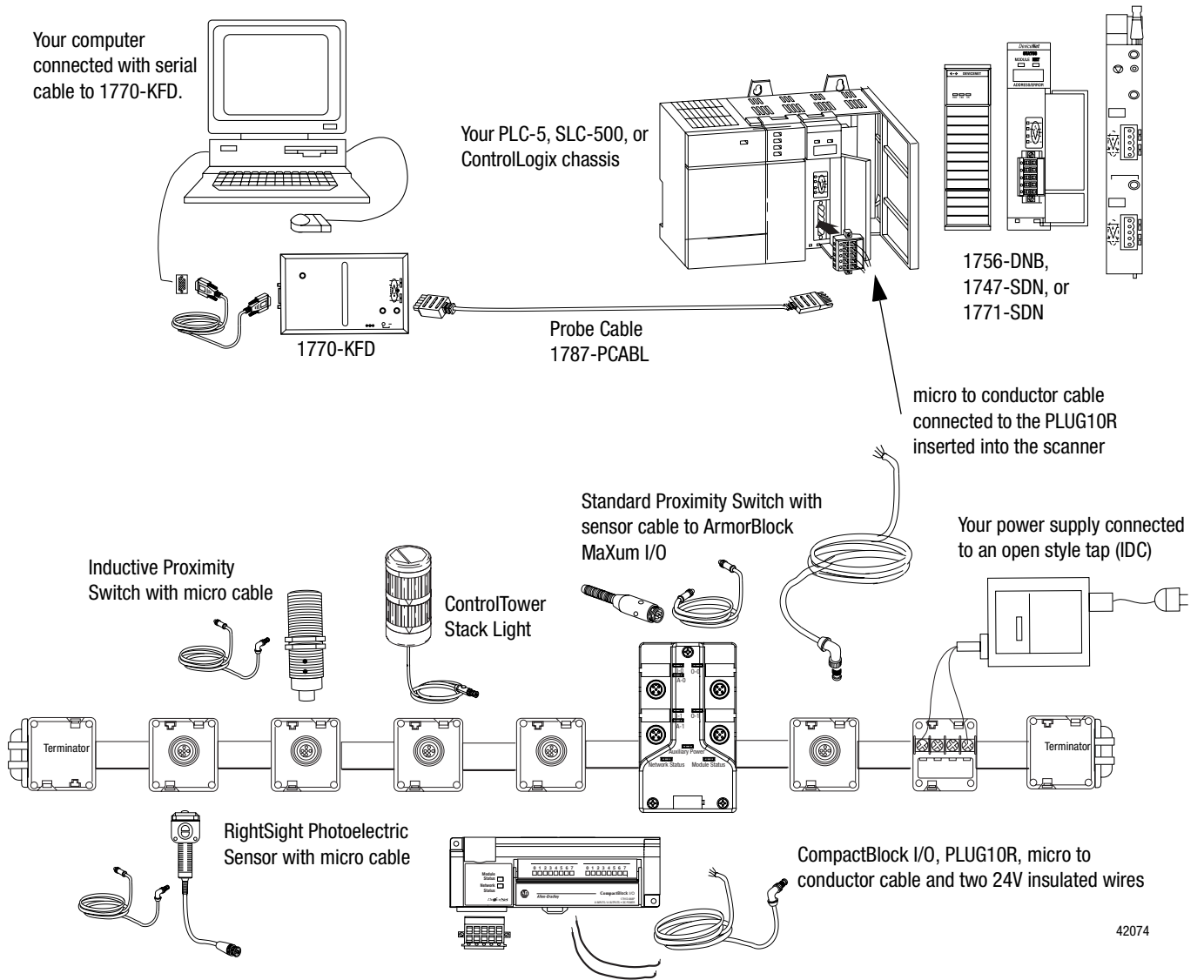

42074

SKITS 2, 4, and 6

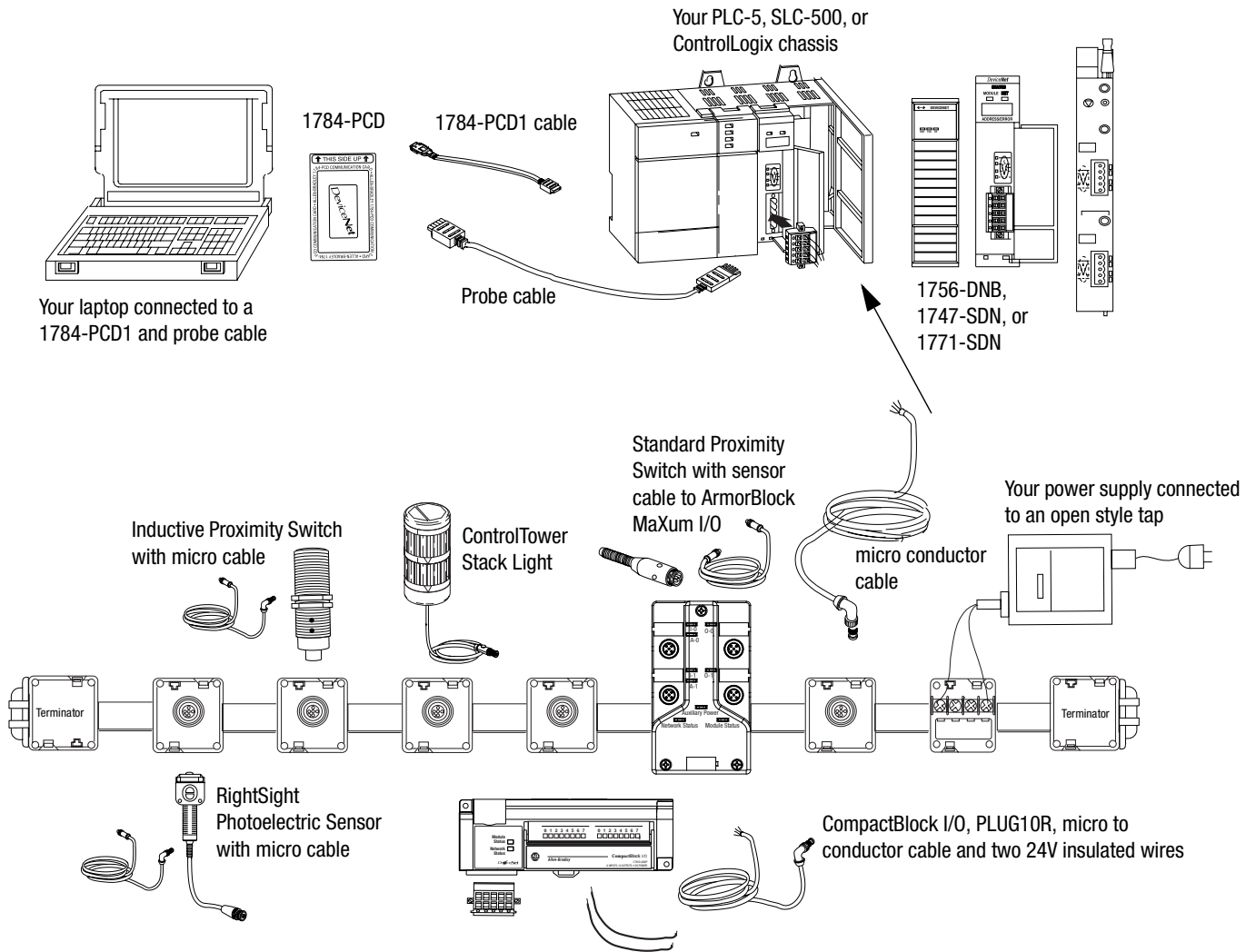

42075

SKIT 7

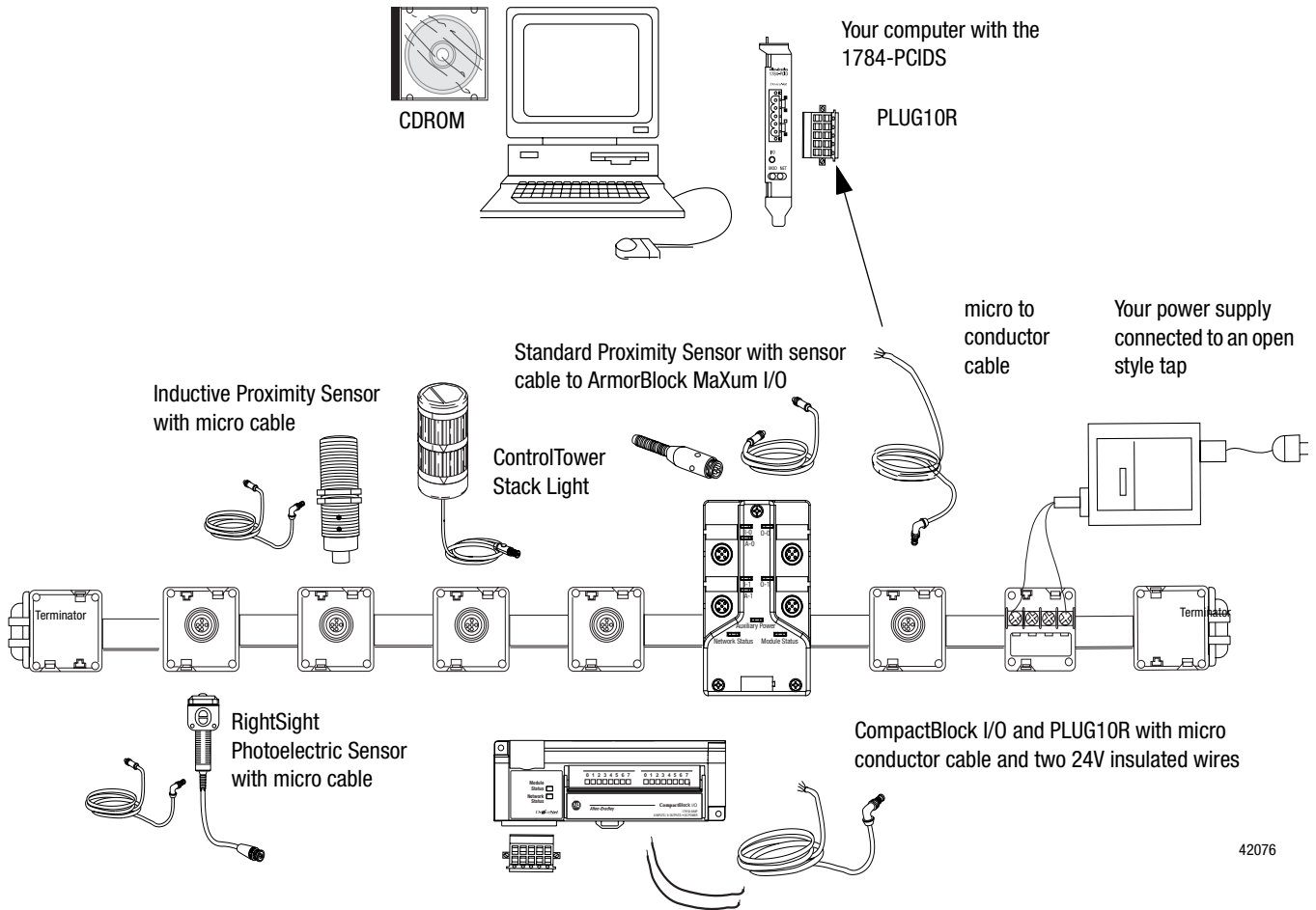

42076

Assemble the KwikLink Media System

Follow the figure below for placement of the KwikLink IDC taps and the ArmorBlock MaXum base and seal block (2-9 through 2-12). Also refer to the instructions that are printed on the outside of the IDC tap package, and to the DeviceNet Cable Planning and Installation Guide publication no. DN-6.7.2. Don't connect any devices yet, you'll be doing that in Chapter 3.

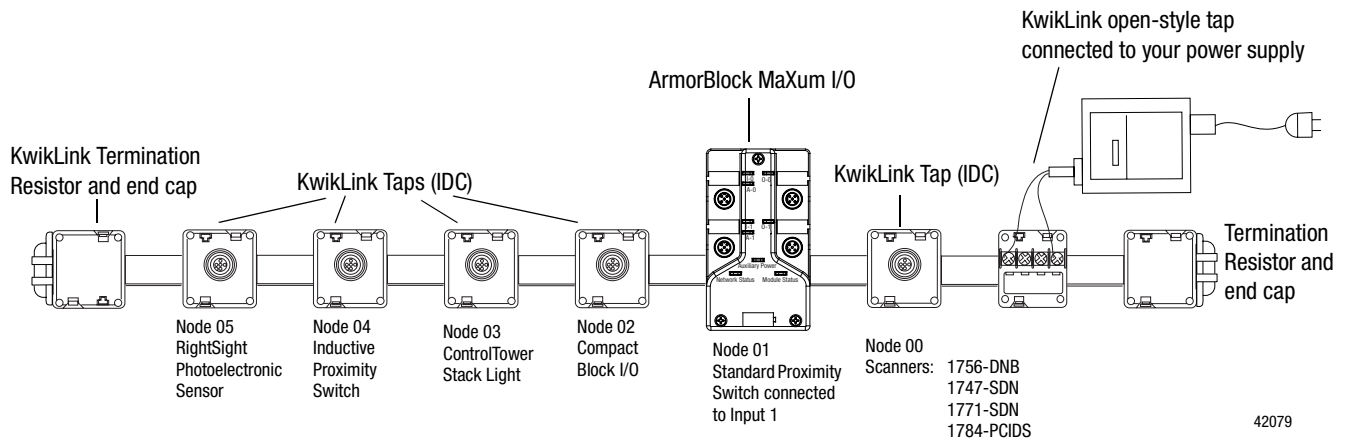

The KwikLink taps are also called Insulation Displacement Connectors (IDC). Follow these steps attach the KwikLink taps (IDC) to the flat KwikLink cable:

1. Lay the cable in the hinged base. Pay attention to the keyed profile. The unkeyed edge is closer to the hinge; the keyed edge is toward the latch.

IMPORTANT

Prior to closing the connector, be certain that the IDC blades do not protrude from the housing. If the blades are exposed, gently push them back into the base. In the event that the blades do not retract easily (or retract only partially), verify that the IDC screws are not partially driven.

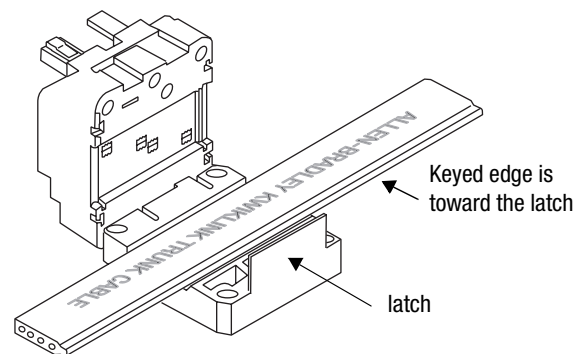

2. Close the hinged assembly, apply pressure until the latch locks into place.

TIP



The latch has two catches. The first catch loosely holds the connector on the cable. The second catch needs more pressure applied to close the connector tightly. If the cable is not in the correct position, the connector will not close.

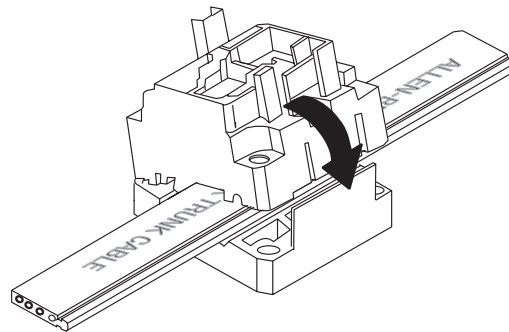

30475

3. Be certain that the cable is straight before moving on to step four.

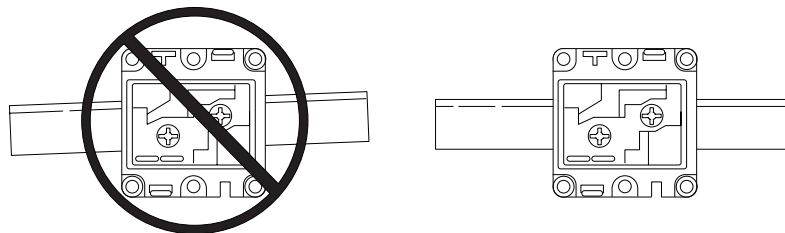

30492

ATTENTION



Be certain that the cable is straight before tightening the screws. Improper seating of the cable may cause a weak seal and impede IP67 requirements.

4. Tighten down the two screws at the center points of the hinge and latch sides of the base; tighten down the latch side first. Take care to avoid stripping, ample torque should be 5.56 N (15 in-lbs).

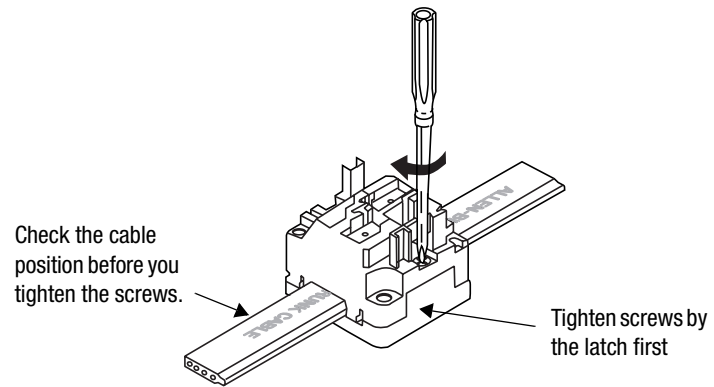

5. Drive the IDC contacts into the cable by tightening down the two screws all the way into the center of the base assembly.

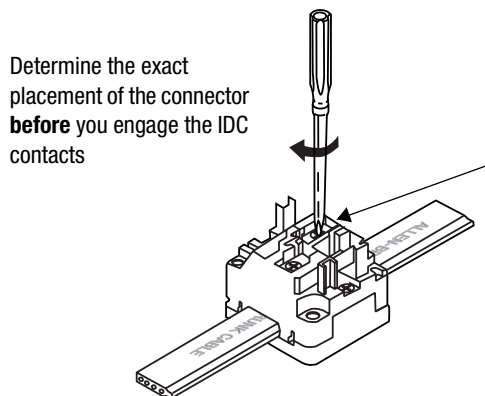

ATTENTION



Once the IDC contacts are driven into the cable, the module should not be removed.

6. Line up the keyed rectangular holes of the micro/open/terminator connection interface with the matching posts on the base and snap the micro module into place.
7. Secure the micro/open/terminator module by driving screws through the two remaining mounting holes.

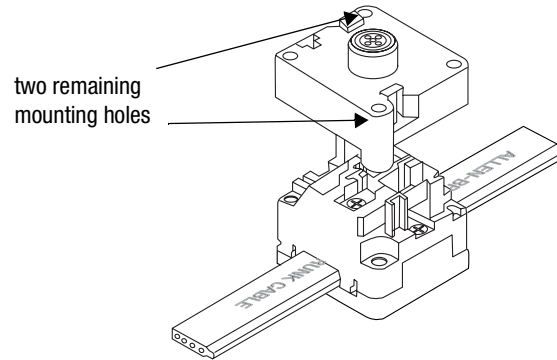

30478

8. Connect all the taps, repeating steps 1 through 7. Refer to the tap package instructions for additional information.

Your network should look like this:

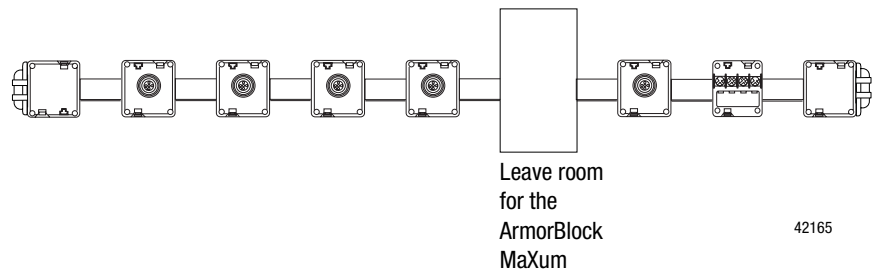

42165

Install the ArmorBlock MaXum Base

Follow these instructions to install the ArmorBlock MaXum base onto the KwikLink media system. Refer to installation instructions that come with the MaXum Base for additional information.

Mount the Cable Base

For the Starter Kit example you do not need to mount the base. The KwikLink media system will remain as a moveable table top object. The section “Mount the Cable Base” for the Starter Kit application is for informational purposes only.

You can mount the cable base either vertically or horizontally. Cable bases accommodate either 4 or 8 point ArmorBlock MaXum modules. Additional space allowances must be made for 8 point ArmorBlock MaXum modules.

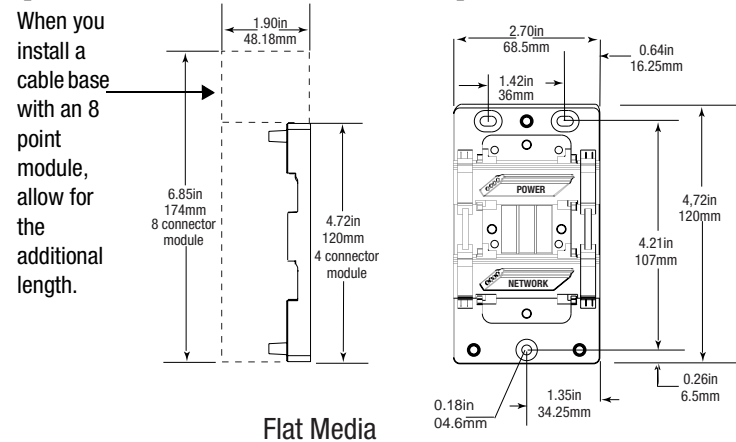

41536

Some network installations may subject the cables to a great deal of flex. In this case, we recommend that you clamp the flat media cable at a specific distance from the base. Refer to publication, DN-6.7.2, DeviceNet Cable Planning and Installation Manual for more information.

Prepare the Flat Media Cables

For the Starter Kit example, you only use the cable through the network seat. The power seat will not be used. The power seat is used to power the network and output devices. You cannot draw power from the network to power output devices such as motors.

They need to have another 24v power source. The Starter Kit power will come from the open style tap connected to your power supply.

IMPORTANT

For the Starter Kits, you will not be using the power option for the ArmorBlock MaXum I/O. Install the caps to seal the power opening.

IMPORTANT

Because the Starter Kit is a simple application, you are going to power an output, such as the CompactBlock off the DeviceNet Network. In a real world application you would not do this. You would use the power cable from the ArmorBlock MaXum to power your outputs. Refer to Appendix B in publication DN- 6.7.2, DeviceNet Cable Planning and Installation Manual for more information.

The 1792D-CBFM cable base using a KwikLink flat media system accommodates the following cable routings while maintaining full IP67 sealing integrity. Determine if your network system will pass through or end at this cable base. These options are available:

- DeviceNet and Auxiliary Power cables both pass through the base.
- DeviceNet cable only passes through the base.
- DeviceNet passes through, and Auxiliary Power ends at this base.
- Both DeviceNet and Auxiliary Power end at this base.

IMPORTANT

If you place the ArmorBlock at the end of a cable run, you must apply end caps to cables that end at the base **prior** to installation. The caps seal the cables. The **cable**, with the end cap applied, must end between the two lines on the cable base as shown below. When Auxiliary Power is not used, seal both openings to the power slot.

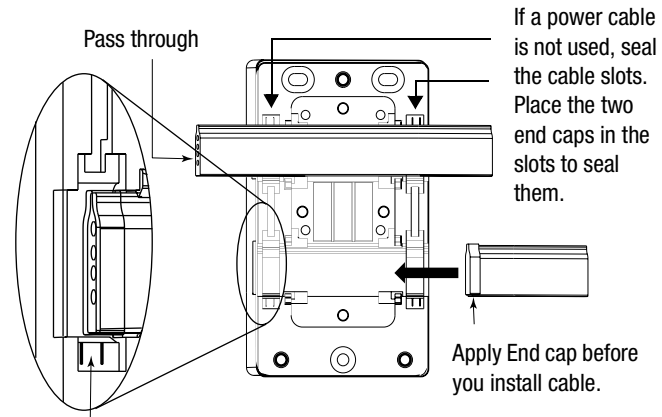

The **cable** must end between these two lines. The clear end cap allows you to see the cable position.

30827-M

Attach the Flat Media Cables

The KwikLink DeviceNet™ flat media cable is a four-conductor cable.

It has a key design feature that allows it to “seat” in the cable base in only one direction. Labels indicate which slot to use for the Auxiliary Power and DeviceNet connection.

Follow these steps to attach the flat media cable:

1. Remove the end cap covers from the storage area. These are used to cover the cables when they end.

End cap storage
(2 caps are provided)

2. Apply an end cap to cables that end at this point in your network. End caps cannot be applied after the cables are attached to the base.

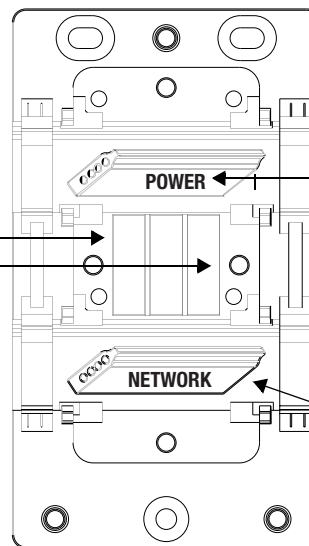
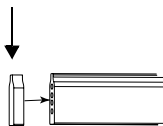

3. Align the key features of the cable and base. The cable and cable slots are angled. The cables can only be placed in one direction.

4. Modules with outputs require an Auxiliary Power cable. If the module you use has outputs, snap the black power cable into the slot labeled POWER. (not applicable to the Starter Kits)

5. Snap the gray DeviceNet cable into the slot labeled NETWORK.

POWER and NETWORK labels indicate Auxiliary Power and DeviceNet cable placement.

30829-M
41530

Attach the Seal Block

The seal block contains the contacts that pierce the cable. Contact occurs when you attach the seal block to the cable base. The seal block is designed to attach to the base in only one direction.

ATTENTION



The seal block has extremely sharp contacts. Do not press against them with your fingers. You may be injured.

Be certain to properly align the seal block when you attach it to the base. This will maintain the integrity of the sealed base. You can only pierce the cable once. Once pierced, the seal block must not be removed. This will ensure the inner conductors are not exposed.

Avoid injury.
Pierce
contacts are
extremely
sharp.

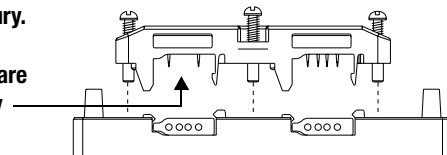

**Only one attempt to pierce the
cable is allowed.**

41534

To install the seal block:

1. Position the seal block over the cable base.
 - a. Match the arrows on the bottom of the base and seal block.
 - b. Align the four captive screws in the seal block with the receptacles in the base.
2. Tighten the screws with a torque of 8 to 10 inch-pounds to secure the module to the base. To assure that the cable is pierced evenly, tighten each screw a little at a time.

IMPORTANT

There are 3 seat lines on the sides of the seal block, under the captive screws. As the screws are tightened these lines meet the cable base. At this point the seal block is fully seated

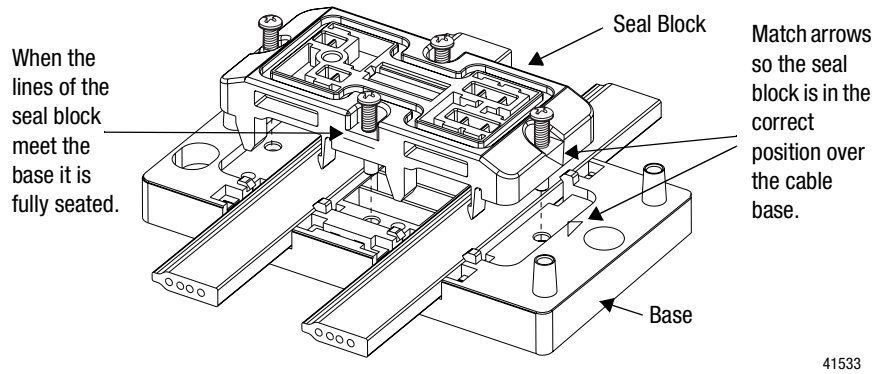

IMPORTANT

You will set the node address and place the top of the ArmorBlock MaXum I/O onto the seal block when you commission the node in Chapter 3.

ATTENTION



Be certain that all screws and end caps are securely tightened to properly seal the base against leaks and maintain IP67 requirements.

At this point, your network should look like this:

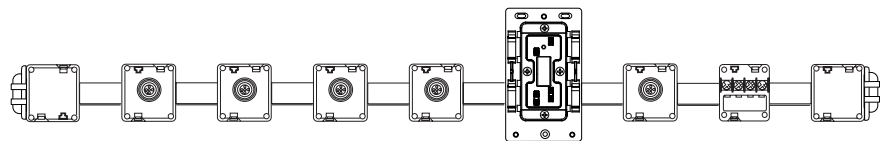

42166

Connect Your Power Supply

The power supply that you select to use with your Starter Kit must be within the DeviceNet specifications. Refer to the DeviceNet power supply specifications in publication, DN-6.7.2, DeviceNet Cable System Planning and Installation Manual for detailed information.

Follow these steps to connect your power supply:

1. Connect your 24V dc power supply to the KwikLink open style tap.
2. Connect +24V dc to red (+).
3. Connect -24V dc to black (-).

TIP

Both the white and blue terminals are unused.

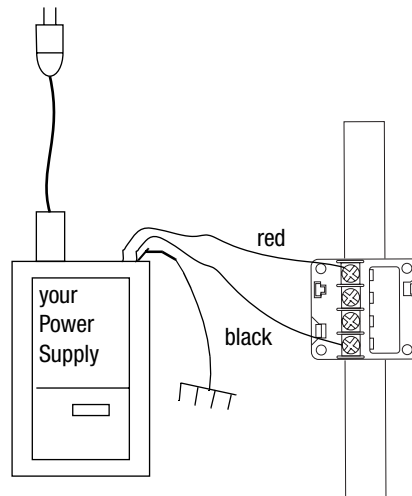

42033

Ground Your Network

You only need to ground a flat media DeviceNet network at one location. Follow the guidelines below:

- Ground the V- conductor at **one** place.
- Make this ground connection with a 25 mm (1 in.) copper braid or a #8 AWG wire up to a maximum 3m (10 ft) in length.
- Use the same ground for the V- conductor of the cable system and the chassis ground of the power supply. Do this at the power supply.

Wire Color	Wire Identity	Usage
white	CAN_H	signal
blue	CAN_L	signal
black	V-	power
red	V+	power

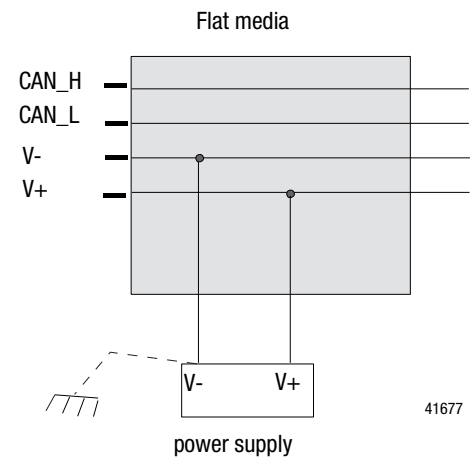

Set up the 1771-SDN Scanner for SKITs 3 and 4

The scanner is the DeviceNet master (controller interface) coordinating all control data to and from all devices on the DeviceNet network. This DeviceNet data is transferred between:

- the SLC-500 and 1747-SDN via M1/M0 and discrete I/O transfers
- PLC-5 and 1771-SDN via block transfers and discrete I/O transfers
- PCIDS and logic engine (such as SoftLogix 5 or your own application) via I/O Linx driver running in the NT kernel

This data is then used in the ladder logic program to do the actual control logic.

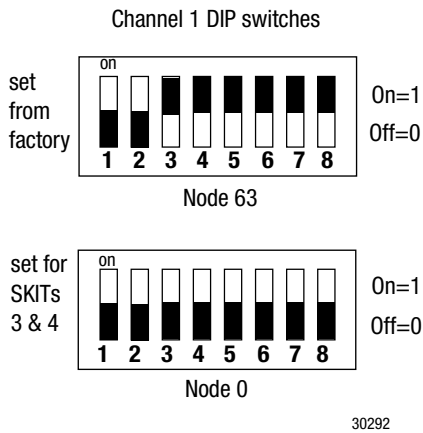

Set Node Address Switches for Channel 1

You must set the node address for the 1771-SDN before you install the scanner and go online. To set the I/O chassis addressing node switches:

1. Locate the switch bank labeled “Channel 1” on the left side of the module.

The address range is from 0 to 63. It will be set to 63 from the factory as shown in the illustration. All autobaud devices are internally set to node 63. The node address for DeviceNet Channel 1 must not conflict with the node address of any other device on the network. For this demonstration, you want to set the address to **0**.

2. Use a ball point pen or a similar object to adjust switches 3 through 8 to match the illustration. All of the switches should be in the off, in the 0 position.

IMPORTANT

Do not use a lead pencil because the tip can break off and jam or short out the switch.

Install Your Scanner

IMPORTANT

Be certain to turn the power to your chassis **off** before inserting your scanner.

After you set the dip switches and with the chassis power off, insert the 1771-SDN scanner into slot 2 of your PLC-5 processor chassis.

IMPORTANT

Refer to installation instructions that come with your 1771-SDN for installation details.

Connect the 1770-KFD for SKITs 1, 3, and 5

To connect the 1770-KFD interface module:

Refer to the installation instructions that are included with your hardware for additional information. The driver for the 1770-KFD is included in the RSLinx software.

1. Connect the RS-232 cable from the 1770-KFD to a serial port on your computer.
2. Connect the RS-232 cable to the 1770-KFD interface module.

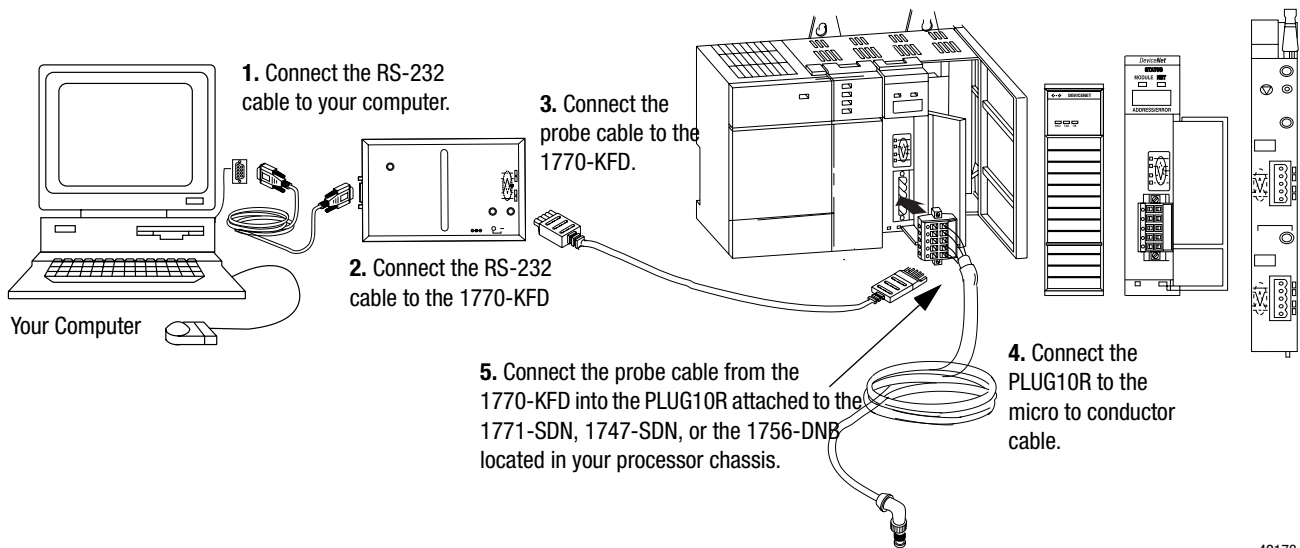

42173

3. Connect the probe cable to the 1770-KFD interface module.

ATTENTION



Do not wire the 1771-SDN Scanner Module with the network power supply on. Wiring the module with the network power supply on may short your network or disrupt communication.

4. Connect the micro to conductor cable to the PLUG10R.

Most open-style devices ship with an open-style connector included. These connectors are also shipped in packages of 10.

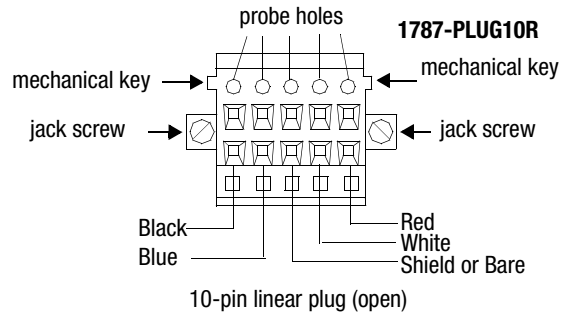

41708

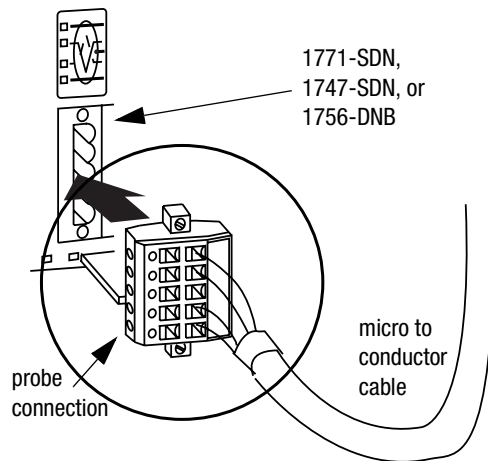

42034

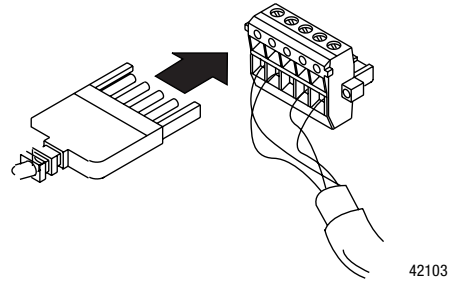

5. Connect the other end of the probe cable to PLUG10R and insert into the 1771-SDN, 1747-SDN, or the 1756-DNB.

Install the 1784-PCD for SKITs 2, 4, and 6

Use the 1784-PCD Installation Utility Disk that comes with the PCD to install the PCD driver software. If the drivers are not installed, you will not be able to select your interface in RSLinx.

IMPORTANT

You can insert or remove the card from a powered or unpowered computer as long as the driver for the card is already installed.

The diagrams below show a PCMCIA 2.1-compliant system. If you use a different computer, your installation may be different. See the installation manual for your computer if you are not using a PCMCIA 2.1-compliant system.

1. Access the PCMCIA slot.

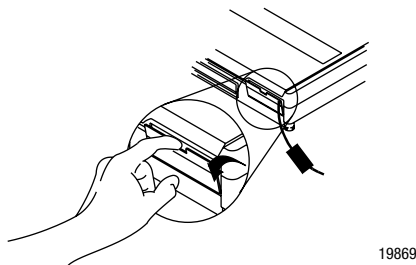

2. Grasp the card by the edges with the DeviceNet logo facing upward and the 68-pin connector facing into the PCMCIA slot.

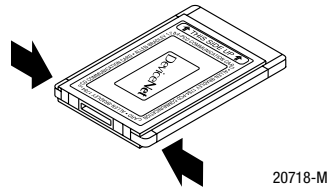

3. Insert the card into the PCMCIA slot and slide it in until it is firmly seated in the connector. Some computers have an ejector button that pops out when the card is seated in the connector.

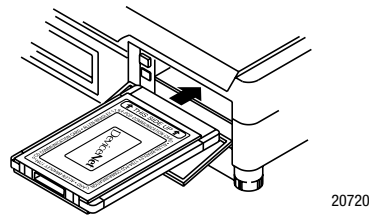

4. Connect the cable to the card.

Connect the 1784-PCD to Your Network for SKITs 2, 4, and 6

Follow these steps to connect the 1784-PCD to you network:

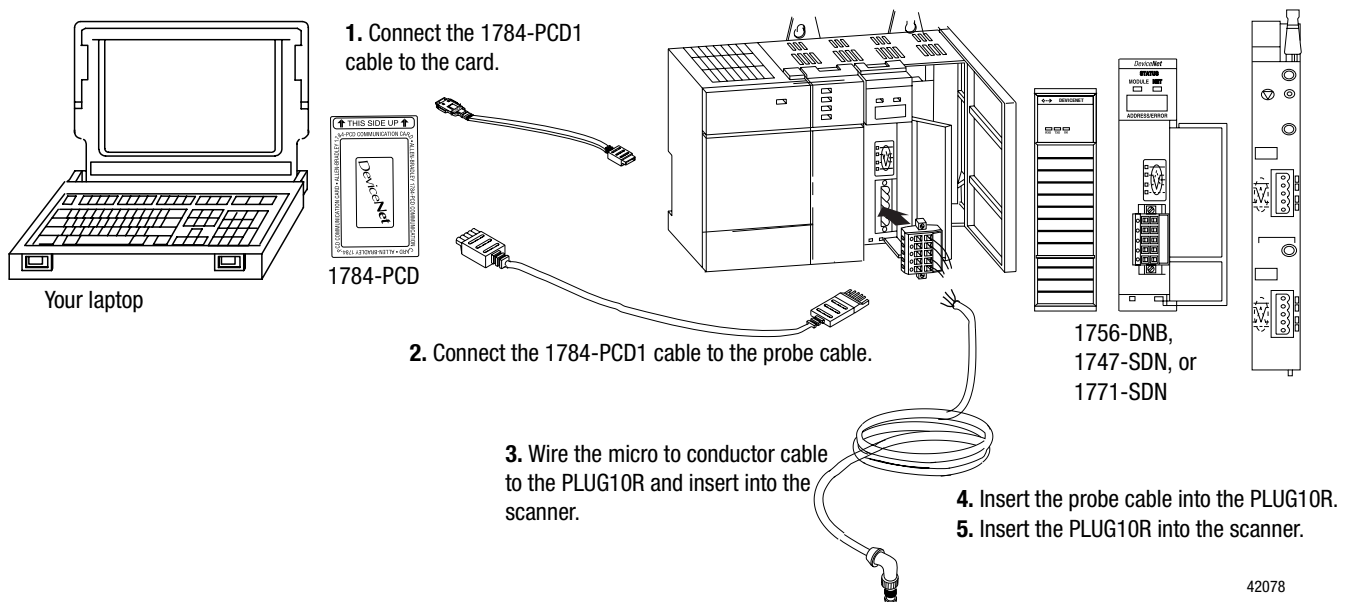

1. Locate the 1784-PCD1 cable and connect it to the PCD card installed in your laptop computer.
2. Attach the probe cable to the other end of the 1784-PCD1 cable.
3. Connect the micro to conductor cable to the PLUG10R.

Most open-style devices ship with an open-style connector included. These connectors are also shipped in packages of 10.

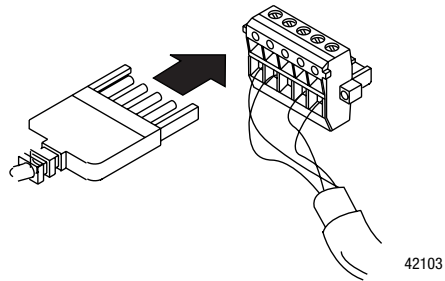
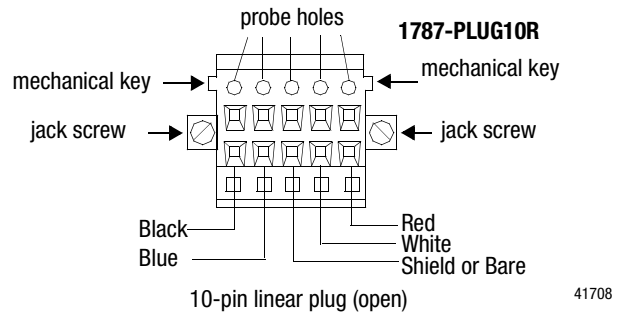

4. Connect the other end of the probe cable to PLUG10R and insert into the 1771-SDN, 1747-SDN, or the 1756-DNB.

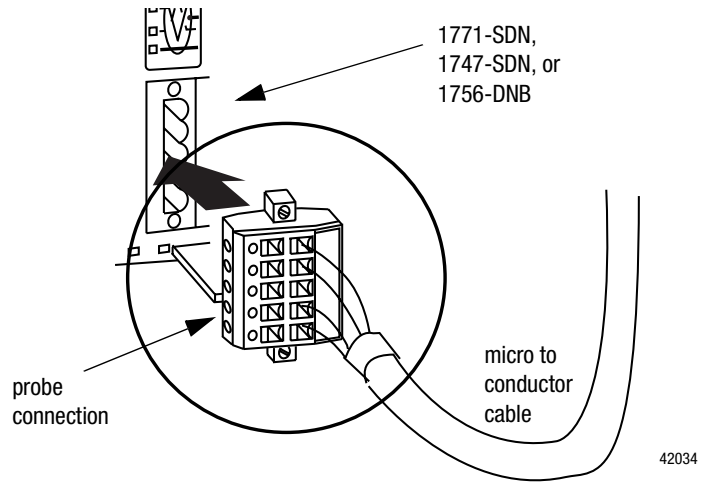

IMPORTANT

Be certain to install the required drivers for your 1784-PCD or RSLinx will not know to look for the hardware when you go online with your network. Refer to your 1784-PCD documentation for details.

The 1784-PCD is now a part of your network.

Remove the 1784-PCD Card

If you want to remove the card on most computers, you press the release button and remove the card from the slot. If this is not applicable to your computer, follow the instructions specified in the card's user manual

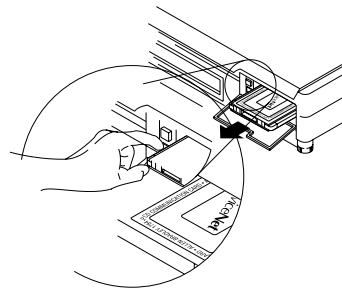

Set up the 1784-PCIDS for SKIT7

The 1784-PCIDS is part of the I/OInx family of real-time hardware drivers for Allen-Bradley NetLinx scanner modules. The 1784-PCIDS communication interface card, with appropriate software, is a peripheral component interconnect (PCI) open-bus interface card that provides DeviceNet configuration and I/O scanner capabilities. The I/OInx Application Programming Interface (API) lets software-based control applications read and write I/O data in real-time to PC hardware and scanners.

Install the 1784-PCIDS Card

IMPORTANT

Be certain that you know how to:

- install hardware in your computer
- configure the computer's options before you install the 1784-PCIDS

Consult your computer's documentation for specific information.

You need a Phillips-head or a flat-head screwdriver, depending on your system.

To install the card:

1. Gain access to the computer's expansion slots.
2. Insert the card into an open PCI slot in the computer

TIP

The 1784-PCIDS card is 4.2" (10.7 cm) high and 4.721" (12 cm) long.

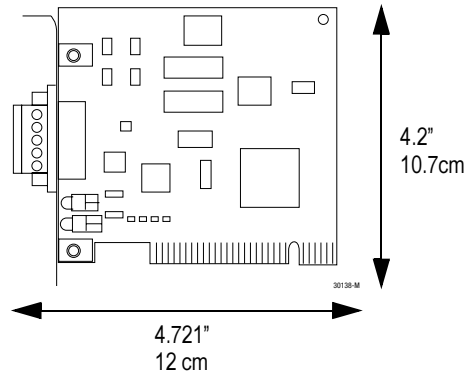

Access the computer's expansion slots

To install the 1784-PCIDS card, you must access the computer's expansion slots. Refer to your computer's user guide for instructions on how to:

1. Turn off your computer.
2. Remove the computer's cover.
3. Select a vacant PCI expansion slot.
4. Remove the slot's expansion cover by loosening the screw on the back (rear bracket) of the computer.

Insert the Card

To insert the card inside the computer:

1. Follow the card handling instructions included with your card.
2. Insert the 1784-PCIDS card into the edge connector and tighten the expansion slot screw.
3. Turn on the computer to make sure it powers up correctly.
4. Replace the CPU cover (when computer comes up correctly).

Install the 1784-PCIDS Drivers

Follow these steps to install the PCID(S) drivers:

1. Insert the CD in the CD-ROM drive.

IMPORTANT

Exit all Windows programs before you run this Setup program.

TIP



The CD-ROM has the Windows Autorun loaded. Once the CD is inserted into the CD-ROM drive, if you have Autorun configured, the installation will automatically start at the first setup screen.

If Autorun is configured, go to step 5.

If Autorun is *not* configured:

1. From the Start menu, choose Run.

You see the Run pop-up window.

2. Type *d:\setup* (if it doesn't appear automatically), where *d* is your CDROM drive letter.
3. Click OK.

You see the progress bar, followed by the welcome screen.

If you want to:	click on:
continue with this Setup	Next You see "Enter name and company."
cancel Setup (because you have not exited other Windows programs)	Cancel Close those programs then run Setup again.

4. Enter your name and company.
5. Click Next.

You see the “Choose Destination Location” screen.

If you want to:	click on:
install software in this directory C:\Program Files\Rockwell Automation\OLinx\DeviceNet	Next
install software in a different directory	Browse and select the directory
exit Setup	Cancel

6. Choose a destination location.

You see the Setup progress bar, followed by the “Setup Complete” screen.

7. Click Finish to complete Setup.

Connect to the Network

This figure and table show the necessary network connections you make to the card. The label (on the retaining bracket) is color-coded for easy wiring.

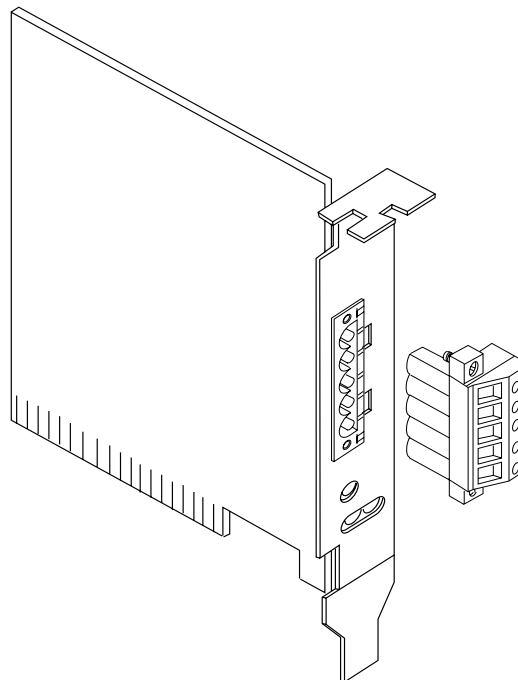

30139-M

pin number:	wire color:	abbreviation:	description:
1	black	V-	24V dc power return
2	blue	CAN_L	data low - data line
3	bare	DRAIN	shield
4	white	CAN_H	data high - data line
5	red	V+	+24V dc

8. Wire the 90° micro male to conductor cable to the PLUG10R and insert into the 1784-PCIDS card.

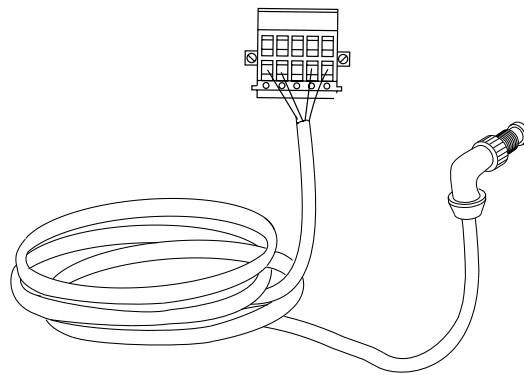

42120

9. Connect the 90° micro male end of the cable to a KwikLink tap.

Your 1784-PCIDS scanner is now connected to your network.

Install RSNetWorx for DeviceNet and RSLinx

RSNetWorx for DeviceNet™ software configures parameters of DeviceNet devices from multiple vendors and helps you troubleshoot the network and performs network diagnostics. This demo version of RSNetWorx for DeviceNet™ only allows you to commission up to seven nodes on your network. Refer to Chapter 3 for more information on the node commission limits.

Follow these instructions:

1. Start Windows, if it does not start automatically.

We recommend that you quit all Windows application programs before you install RSNetWorx for DeviceNet. If Autorun is

configured on your computer, the installation screen appears automatically.

2. Insert the RSNetWorx CD into the CD drive and run the file autorun.exe.

You see:

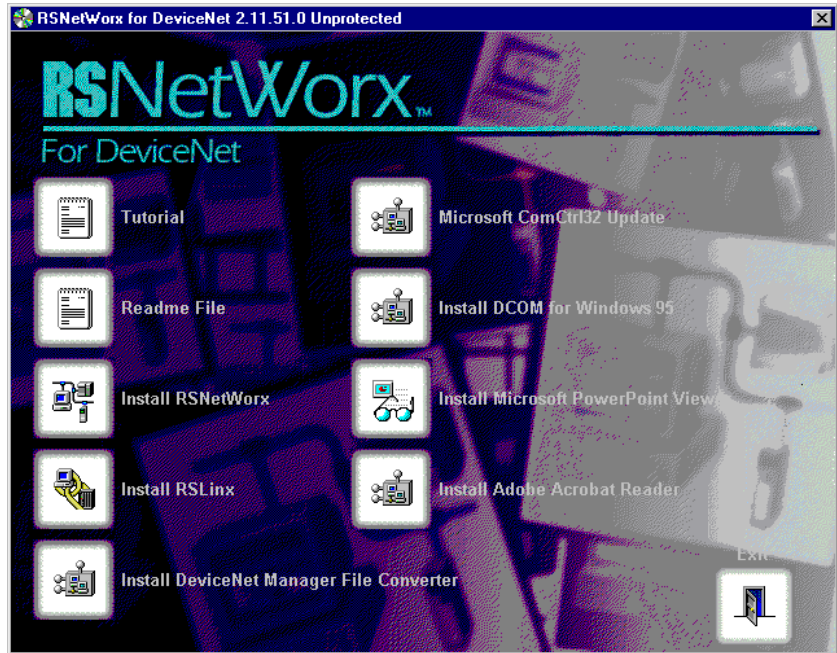

3. Select Install RSNetWorx and follow the instructions.
4. Select Install RSLinx and follow the instructions.

IMPORTANT

When prompted for a serial number use, 9876543210 or any 10 digit number.

TIP



Descriptions on how to navigate through the software as well as the software screens are contained in Help. Refer to the online manuals “Getting Results” and “Quick Start” for information on navigation. They are located on the Help menu.

Summary and What's Next

In this chapter, you:

- constructed your network
- installed the ArmorBlock MaXum base and seal block
- connected your power supply
- grounded your network
- connected your scanner and interface
- installed RSNetWorx for DeviceNet software
- Move on to Chapter 3 to:
- select your scanner in RSLinx
- go online and browse your network
- connect the devices to your network
- commission and assign node addresses for your devices

Notes:

Connect Devices and Commission Nodes

What This Chapter Contains Read this chapter to connect the devices for your Starter Kit and perform node commissioning on the devices. The following table describes what this chapter contains and where to find specific information.

To:	See page:
read about how to node commission	3-2
edit node addresses	3-4
set up your network	3-5
connect and commission the ArmorBlock MaXum I/O with the Standard Proximity Switch	3-14
connect and commission the CompactBlock I/O	3-17
connect and commission the ControlTower Stack Light	3-24
connect and commission the Inductive Proximity Switch	3-26
connect and commission the RightSight Photoelectric Sensor	3-30
see what your network should look like in RSNetWorx	3-35

What is Node Commissioning?

Before you can add any device to a DeviceNet network, it must be commissioned via hardware or software. This means that a node address and a data rate must be programmed into the device.

Node commissioning is the process of setting the node address (0-63) and the data rate (125k, 250k, 500k) for a device. Most devices have their node address pre-commissioned to 63. The data rate is usually set to 125 kbits/second. All devices on any given network **MUST** be at the same baud rate. You cannot mix devices at different baud rates on the same network.

DeviceNet requires a unique node address for each device. This requirement protects against assigning devices with the same address which could cause unpredictable control behavior. RSNetWorx prevents you from assigning the same node address to devices.

The node commission process can be done via hardware (dip switches, rotary switches, thumbwheels) or software (RSNetWorx). Once you commission a device via hardware, you cannot overwrite the settings via software. Many devices support “autobaud”. This allows a device to “set itself” to the proper data rate when it is connected to an operational DeviceNet network. This shortens the steps you need to take when adding or replacing devices on your network.

The Starter Kit devices are all autobaud at a rate of 125kbits/second. The address of 63 and the data rate of 125k are programmed into the device at the factory. Other devices will need to be commissioned in the field. Once a device has been commissioned and attached to a network, you are ready to go.

The Starter Kits have 7 nodes which need to be addressed as follows:

- 00** Scanner, scanners are required to take the lowest possible address
- 01-05** Devices
- 62** Interface, interfaces are required to take the highest possible address. 63 is reserved for factory set devices that have their addresses set by RSNetWorx.

The Demo Version of RSNetWorx allows up to 7 nodes to be commissioned in a network file. This Demo version of RSNetWorx can be converted into a full version when you purchase a full version license from Rockwell.

RSNetWorx for DeviceNet Node Commission Tool

One function of RSNetWorx for DeviceNet software is to provide a way for you to assign node addresses and set data rate parameters for devices that are either:

- connected to a DeviceNet network, or
- connected via a point-to-point connection.

RSNetWorx uses a graphical interface to build your network. Windows navigation provides an easy way to add, delete, and configure devices on your network. RSNetWorx (along with RSLinx communication software) lets you quickly configure your network allowing you to focus more on application attributes and less on hardware configuration and compatibility.

RSNetWorx Communicates via RSLinx

RSNetWorx communicates to the network through RSLinx. RSNetWorx does not have to be online (connected to an operating network) to setup your network. You can setup your network offline and then download the device scanlist to your scanner. The nodes are not commissioned until you are online communicating to the network.

Device Configuration

Device configuration is the ability to set parameters in a device to establish its behavior on a network.

You can set device parameters by:

- hardware: dip switches, rotary switches, thumbwheels
- software: RSNetWorx via **Electronic Data Sheets (EDS)** or custom configuration applications

Electronic Data Sheets (EDS)

EDS files allow different devices to be added to a project offline. These same EDS files also allow devices to be configured both online or offline. New EDS files can be quickly and easily installed into the RSNetWorx software for any devices, regardless of vendor, that will be connected to your DeviceNet network.

You have all the EDS files you need for your Starter Kit. The RSNetWorx you installed already comes with all the EDS files for Rockwell products currently available. You can obtain new Rockwell Automation DeviceNet device EDS files from our website: www.ab.com/networks/EDS.

Prepare to Add Nodes

At this point you should have read and performed tasks in Chapters 1 & 2. Review your checklist from Chapter 1. You should have:

- read about a DeviceNet network
- identified, organized and secured what you need to use this Starter Kit
- located Rockwell Automation support services
- assembled the KwikLink media
- connected the ArmorBlock MaXum I/O base to the KwikLink media and attached the seal block
- connected and grounded your power supply
- installed the scanner into your chassis
- connected your interface
- installed the required software drivers for PC cards
- connected your PC
- installed the Demo Version of RSNetWorx for DeviceNet

Set up Your Network

Follow these directions to set up your scanner using RSLinx and RSNetWorx.

For our demonstration, we are using a DH-485 connection between the SLC-5 and the PC (via an Allen-Bradley PIC module). The screens you see may be different than the screens provided in this manual.

1. Check to be certain that you have installed the required drivers and that the your scanner is not displaying any error codes. See Appendix A: Numeric Code Display Summary.
2. Check to be certain that your scanner and interface has power.

TIP



- Remember to use the RSNetWorx for DeviceNet and RSLinx online help systems  and manuals for additional information.
- Click the Help buttons on dialog boxes to display step-by-step procedures, or press F1 while on individual controls, such as check boxes, edit boxes, grids, and list boxes to display pop up definitions of those controls.

IMPORTANT

If your Starter Kit is SKIT7, you must have 2 devices on your network before you select the 1784-PCIDS driver in RSLinx.

Configure Drivers

1. Start RSLinx.

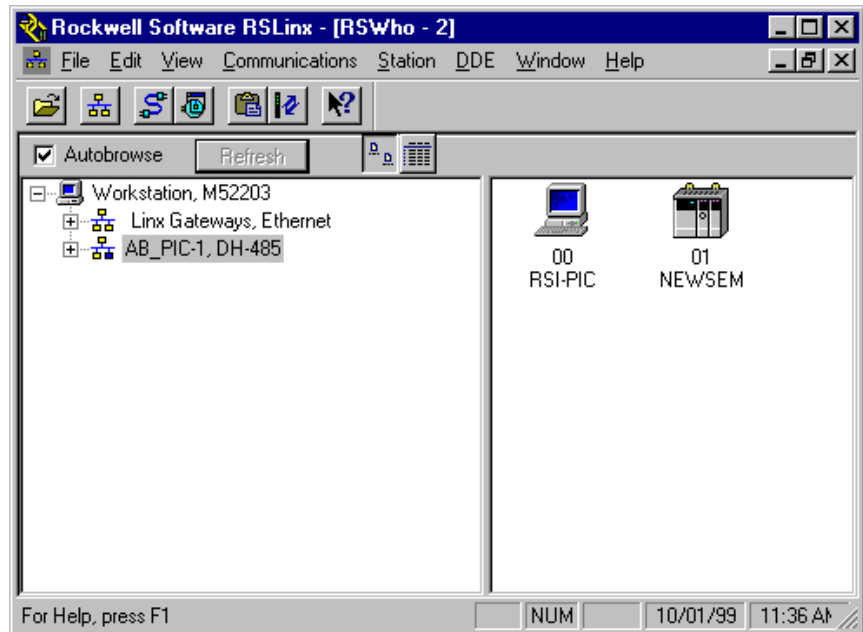

2. Configure Driver by clicking  or by using the menus:

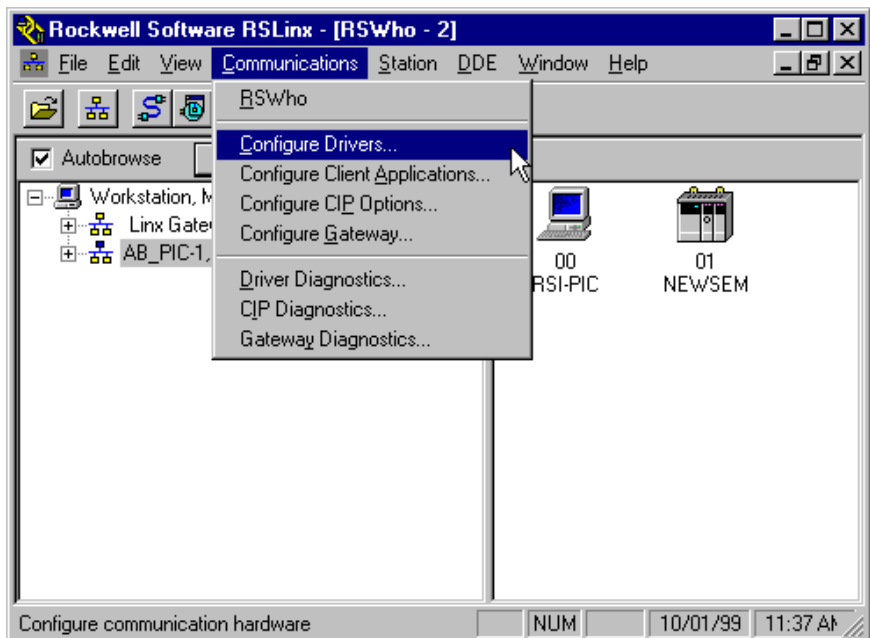

You see:

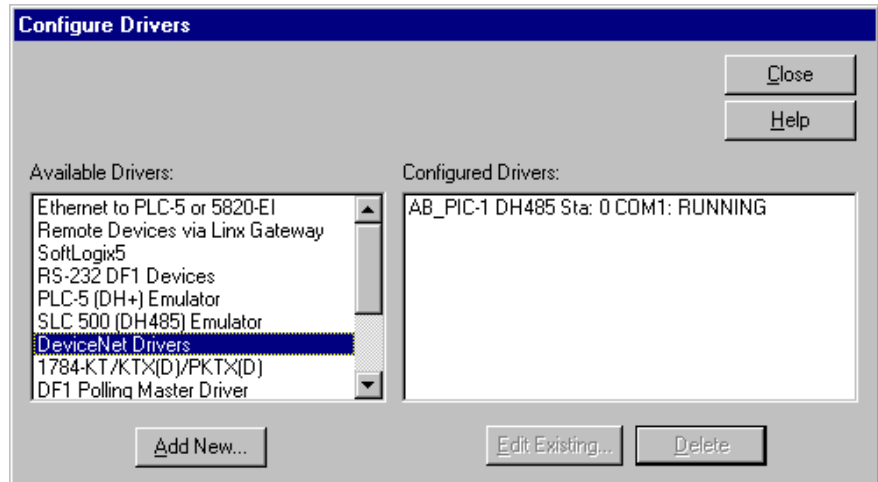

3. Select DeviceNet Drivers by clicking once.

4. Click  .

You see:

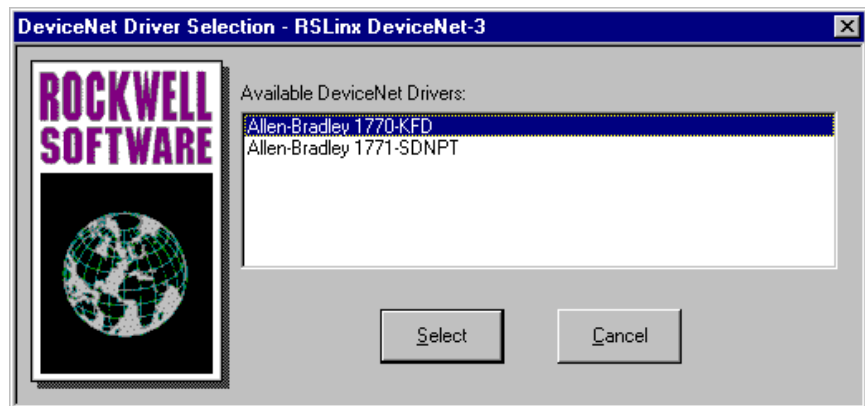

5. Click on your interface.
 SKITS 1, 3, and 5 1770-KFD
 SKITS 2, 4, and 61784-PCD
 SKIT71784-PCIDS

If your interface is not listed, check to be certain that you properly installed the driver for your interface.

6. Click  .

You will see a different screen for all three interfaces. Below is an example of the 1770-KFD Driver Configuration screen:

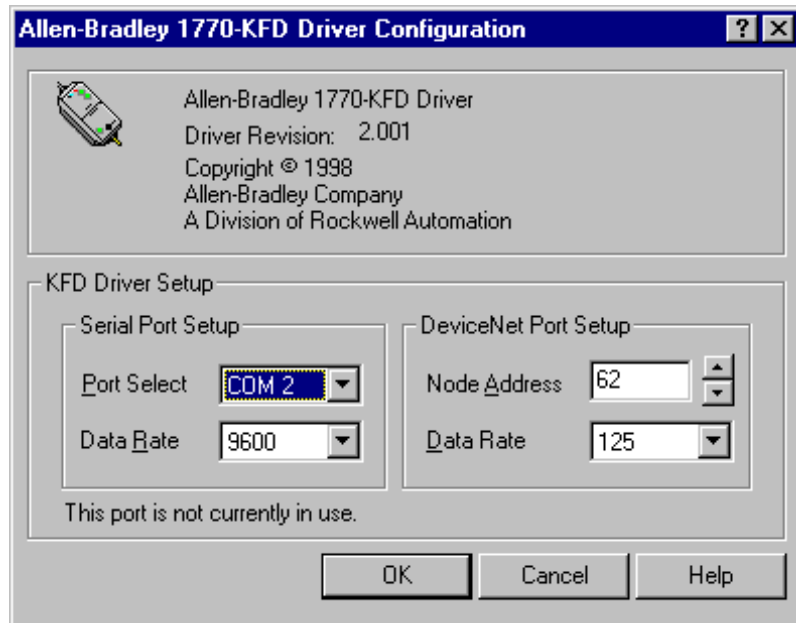

7. Change the Driver configuration if needed. Serial port setup may vary, depending on the PC you are using. For the Starter Kit demonstrations you want the DeviceNet node address to be 62 and the data rate to be 125.

TIP

If your Starter Kit is SKIT7, the node address for the 1784-PCIDS must be 00.



8. Click .

9. Please wait while RSLinx is initializing your interface.

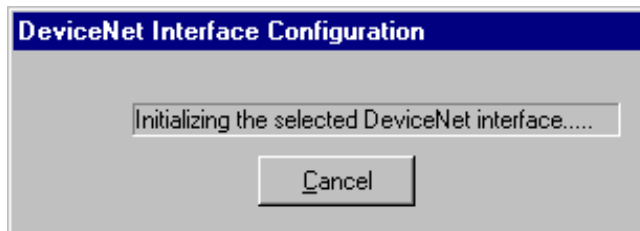

If you receive this message, be certain that your network is powered and your interface is connected properly.

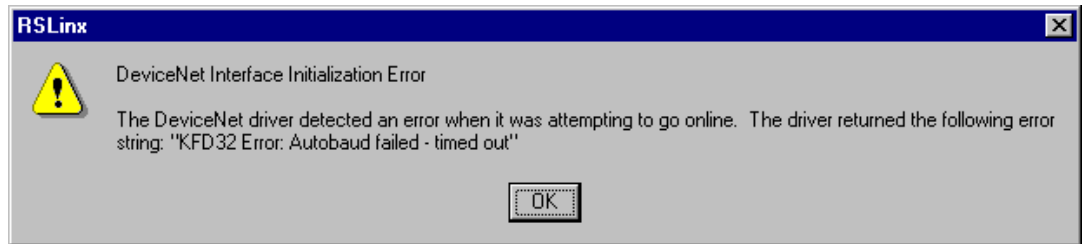

The version of RSLinx may display a slightly different screen.

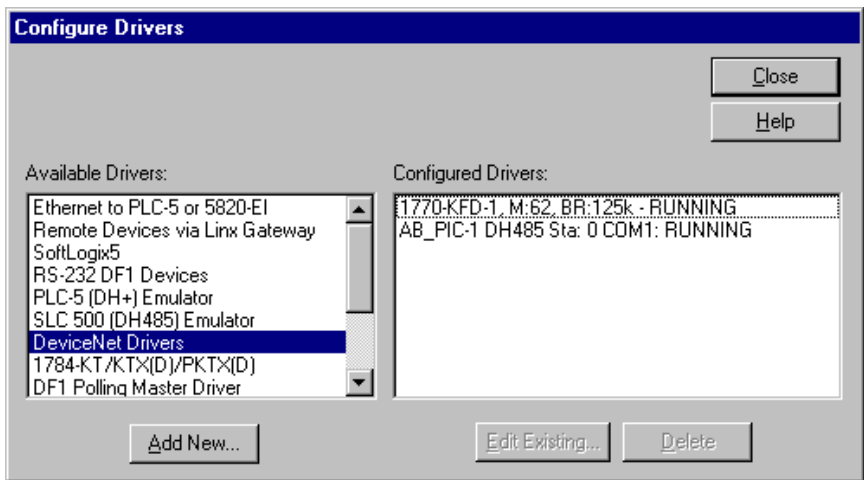

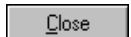
10. Your interface is now configured. Click  .

You see:

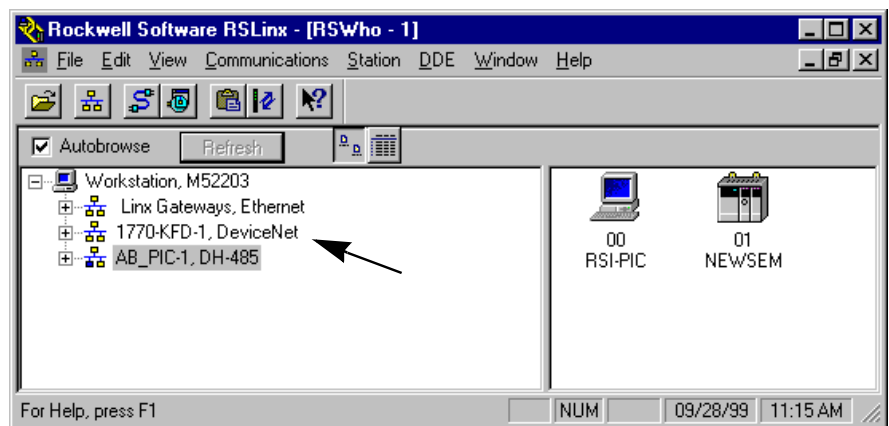

You should see your interface module listed. For SKITs 1, 3, and 5 the 1770-KFD, for SKITs 2, 4, and 6 the 1784-PCD and for SKIT7 the 1784-PCIDS.

If you do not see your scanner, check your connections and repeat the process. You will get an error if the drivers are not installed. Exit RSLinx and refer to the interface installation instructions to install the driver.

11. Click on the **+** next to your interface module.

RSLinx will browse your network and graphically displays what it finds. At this point, you should see your PC and scanner.

You see:

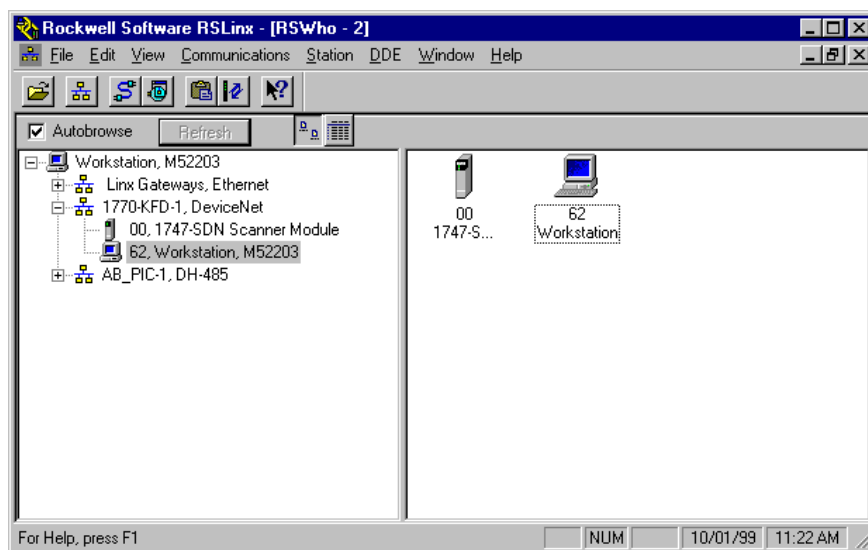

12. Minimize RSLinx.
13. Start RSNetWorx for DeviceNet.

TIP



If you start RSNetWorx before you start and minimize RSLinx you can click  “Browse Network” and RSLinx will start automatically and browse.

14. You should see a blank project window. If not, select File/New to clear the project window.
15. Go online by clicking  on the tool bar.

You see

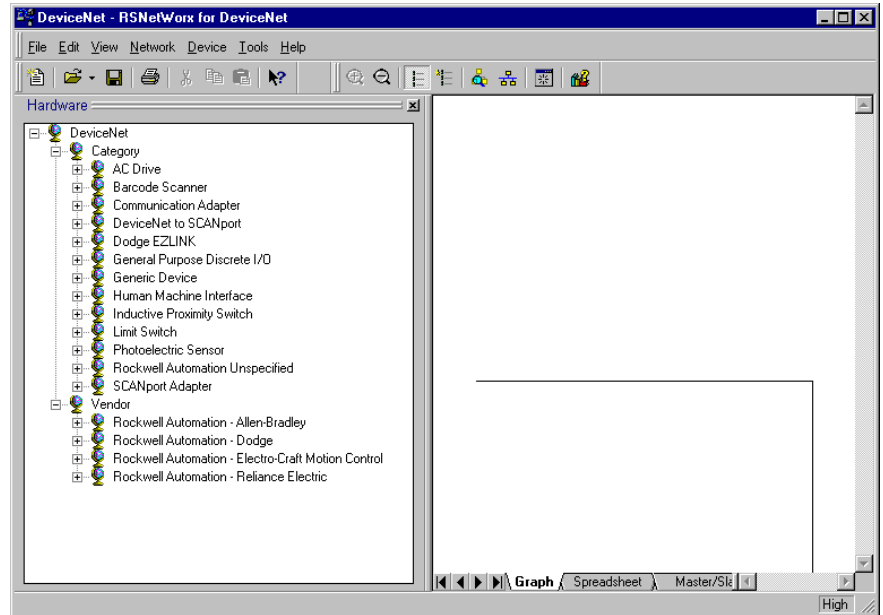

16. Click + next to your DeviceNet interface.

You see:

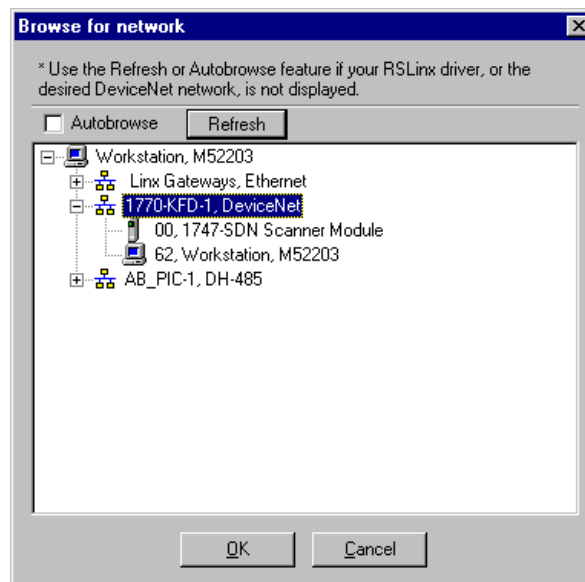

17. Click .

You see:



18. Click to upload information from your network.

Wait for RSNetWorx to poll the network to see what is connected.

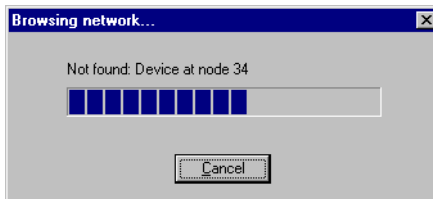

When RSNetWorx has browsed your network you see:

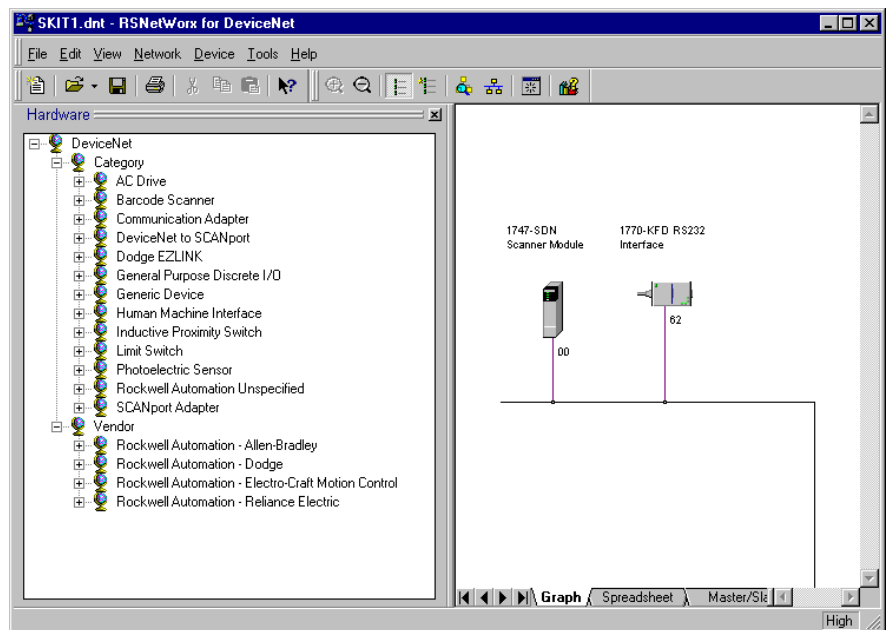

Notice that your scanner has been given the node address of 00. Scanners take the lowest position possible. For SKITs 1 through 6 the interface is at node 62 as assigned when the interface was configured. (Since SKIT7 (1784-PCIDS) is both the scanner and interface, it does not have a node 62, only node 00.) The PC interface should take the highest node address available which is usually 62. Node 63 is the

highest but is reserved for devices when they are first added to your network.

You can change the description of the devices by with the Properties function on the menu Device/Properties. Refer to Edit the Properties on page 3-40 for more information.

Commission Nodes

In this demonstration, you will set the node address for the Stack Light, ArmorBlock I/O, and the CompactBlock I/O using hardware switches. A device is considered “switchless” when it is internally set or when the hardware is set to 99.

The Inductive Proximity Switch and RightSight Photoelectric Sensor are internally “switchless” – their node addresses will be set using RSNetWorx via RSLinx over the network. The CompactBlock will be hardware set to 99. The device data rates will be automatically set by the Autobaud feature.

TIP

The Stack Light and ArmorBlock can be “switchless” also if you set them to 99.



In our SKIT1 example, the scanner and interface are commissioned. The devices that you now need to connect and commission are the:

Device:	Node Address:
ArmorBlock MaXum I/O with the Standard Proximity Switch Set with rotary switches to 01	01
CompactBlock I/O Set rotary switches to 99	02
ControlTower Stack Light Set with rotary switches to 03	03
Inductive Proximity Switch Internal to 99	04
RightSight Photoelectric Sensor Internal to 99	05

Let's connect and commission the devices, one at a time.

Commission the ArmorBlock MaXum I/O Module

You can set the node address with the rotary switches, RSNetWorx™, or other software configuration tool. Valid node addresses are **00** to **63**. Each module is shipped set for node address **63**. The rotary switches are located on the underside of the module.

The two switches are:

- MSD (most significant digit)
- LSD (least significant digit)

To reset the node address, use a small blade screwdriver to rotate the switches. Line up the small black dot on the switch with the number you wish to use.

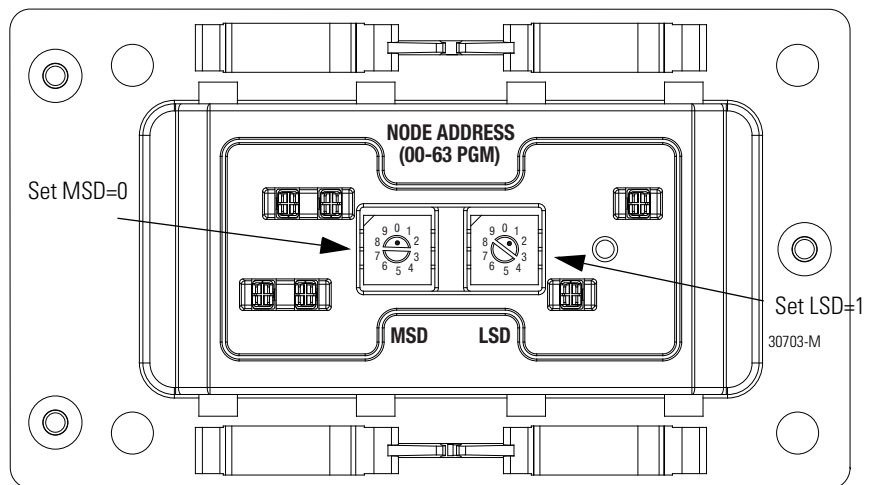

Bottom View of Module

Example: Node Address is set at 01, see small black dots.

The module is equipped with AutoBaud detect. AutoBaud lets the module read the settings already in use on your DeviceNet network and automatically adjust its data rate to follow those settings.

1. Set the node address with the rotary switches to **01** (under the MaXum, marked “MSD”= **0** and “LSD” =**1**)

*Attach the Module***IMPORTANT**

Be certain to properly align the screws to complete the connections between the module contacts and the cable contacts.

1. Position the module over the mounted cable base. Align the three captive screws in the module with the accepting receptacles in the base.
2. Tighten the screws with a torque of 8 inch-pounds (0.904 NM) to secure the module to the base.

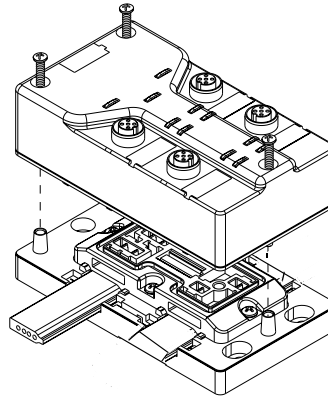

30704-M

ArmorBlock MaXum I/O modules are described in the publications:

- 1792D-5.12 through 5.23 ArmorBlock MaXum Installation Instructions
- 1792-2.1 - ArmorBlock Product Data

3. Connect the Standard Proximity Switch to input 1 on the ArmorBlock MaXum I/O.

Your network should look like this:

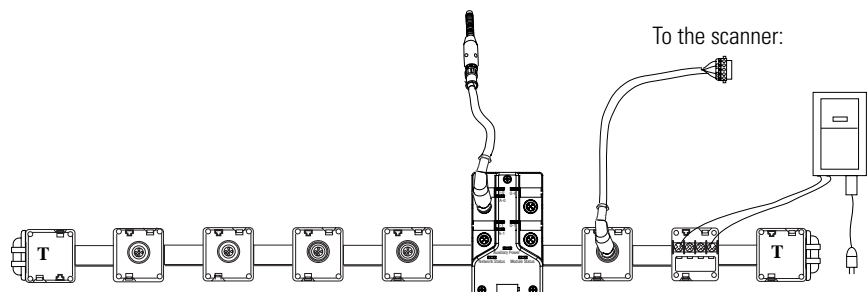

42036

4. Browse the network, Click .

You see:

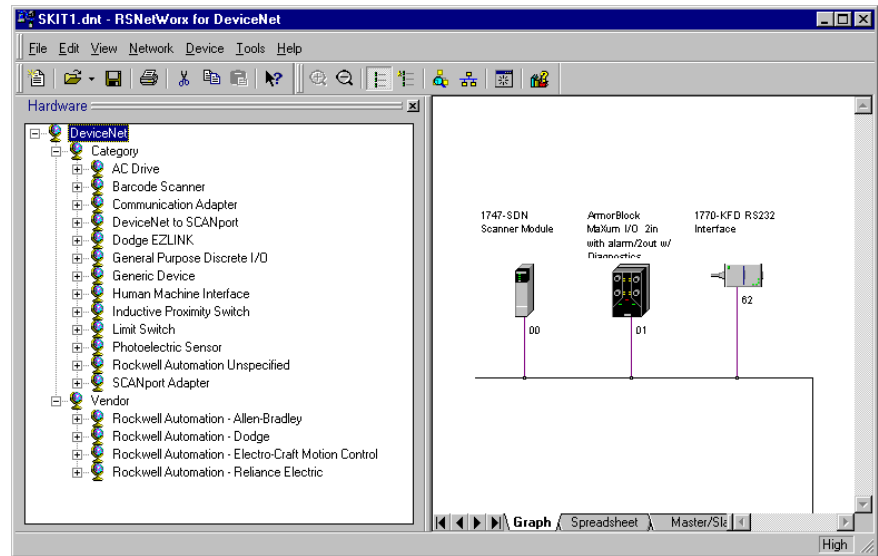

RSNetWorx has found the ArmorBlock MaXum at node 01.

5. Save your network file. Select File/Save and use a filename that relates to your work, such as 1747StarterKit.dnt.

Connect and Commission the CompactBlock I/O Module

1. Open the switch cover on the CompactBlock I/O and check to see if the rotary switches are set to the “switchless” setting of 99. If they are not, set them to 99. You will be setting the node address to 02 in RSNetWorx over the DeviceNet network.

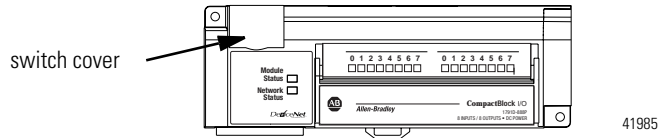

2. Locate a micro to conductor cable and wire the conductor end to the PLUG10R. Use a small screwdriver to open and close the wire clamp on the PLUG10R. Refer to the publication 1791D-5.42, CompactBlock I/O for DeviceNet Modules Installation Instructions for details.

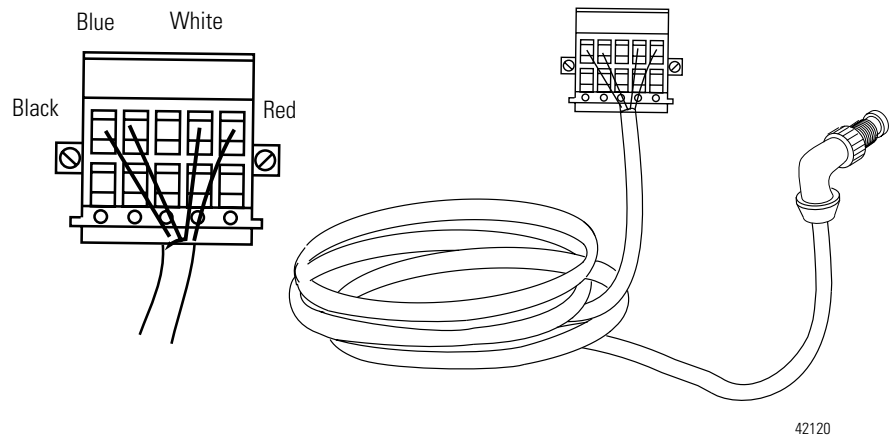

3. Attach two 24V insulated wires to the output section on the CompactBlock. The top bank is positive and the bottom bank is negative.

- Attach the other ends of the insulated wires to a power supply.

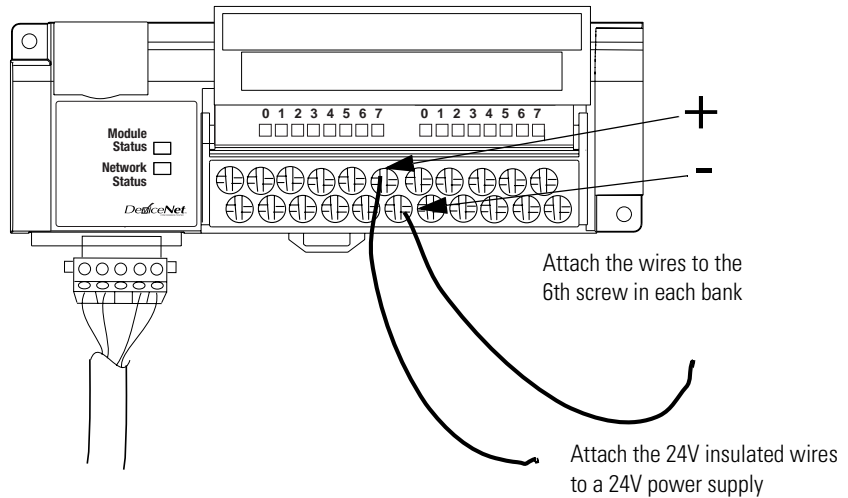

42168

We do not recommend that you use the DeviceNet power to power I/O devices. For the Starter Kit, use an alternative power supply to power the CompactBlock I/O, if possible.

- Insert the PLUG10R into the CompactBlock I/O module.
- Connect the micro end of the cable to a KwikLink tap.

Your network should look like this:

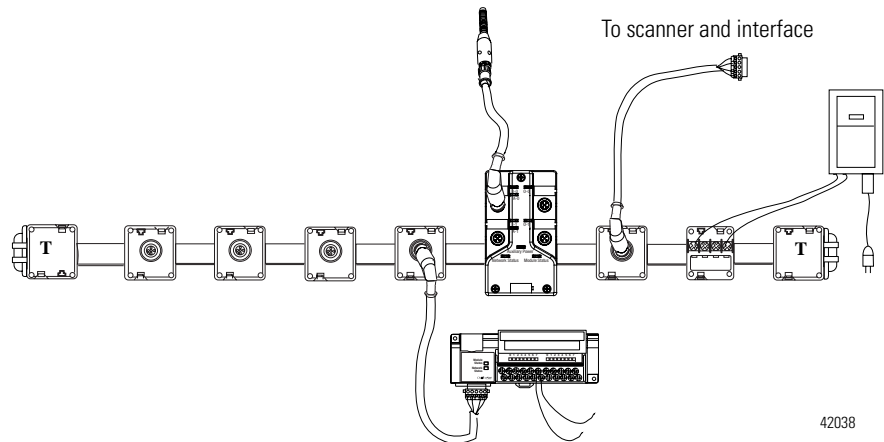

42038

- Watch the LEDs. After the unit cycles you should see a flashing green light at Module Status. Network Status should be off or red. Once you have communicated with the scanner, it should be green. If you don't, check your connections and refer to the installation instructions.
- Go to RSNetworkx.

Commission the CompactBlock I/O Module

Now, place the CompactBlock on the network. Select the device on the “Hardware” side of the RSNetWorx window and drag it over to the network view side and then node commission.

1. Click the + next to General Purpose Discrete I/O to expand selections.

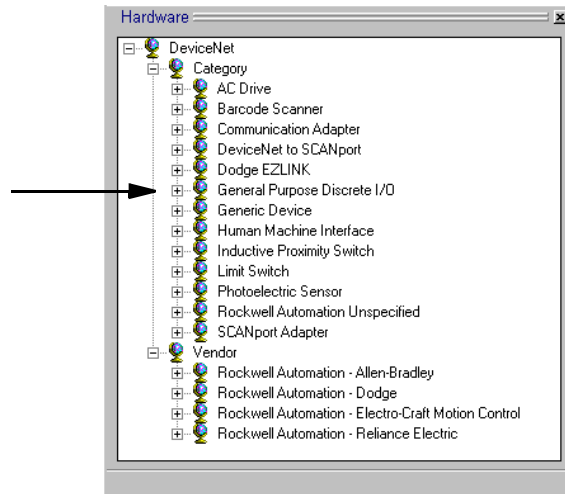

2. Click 1791D Block I/O 8Input/8Output to select and then drag it over to the view side of the window.

You see:

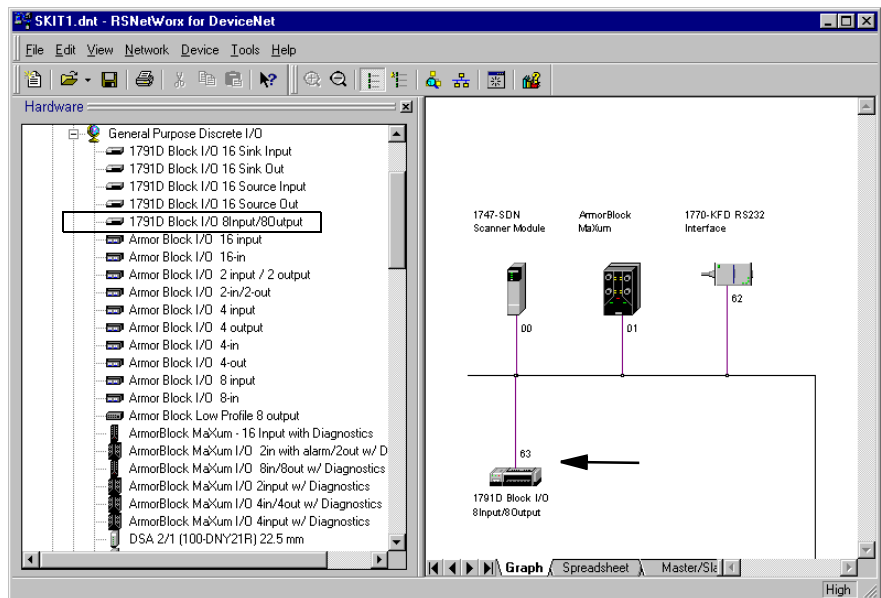

The CompactBlock currently states that it has an address of 63. It shows up as 63 because it is set for the “switchless” setting of 99. You need to commission this device to be node 2.

- 3. Select Tools/Node Commissioning.

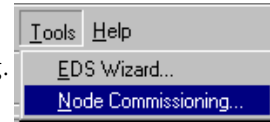

You see:

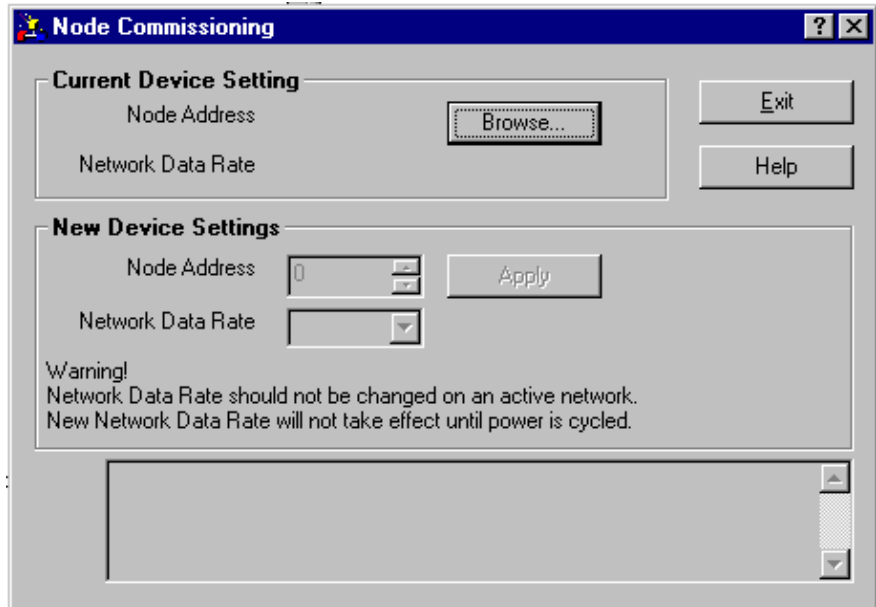

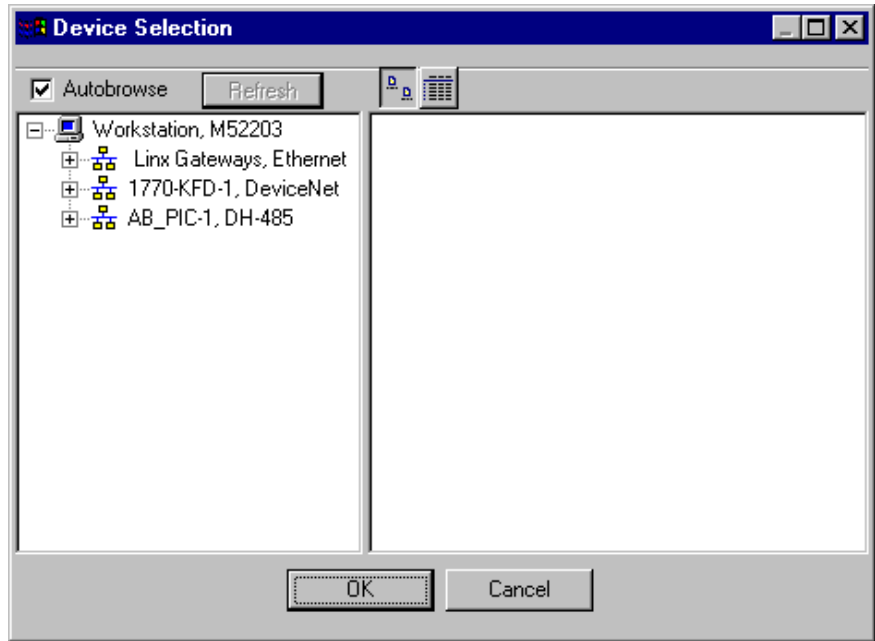

- 4. Click  .

You see:

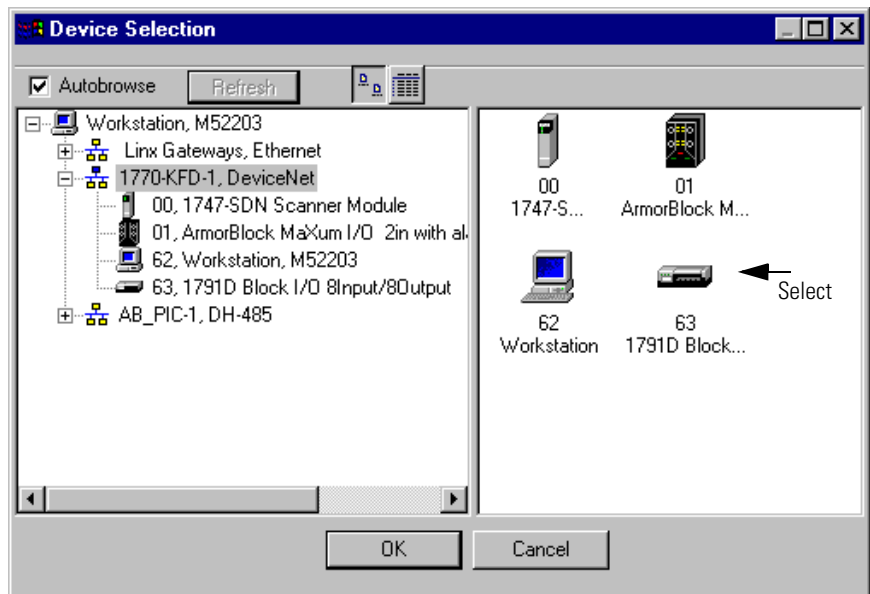

5. Click the + next to your interface. RSLinx performs a Network Who and returns the current devices on the network.



6. Click once on  ⁶³ 1791D Block... to select CompactBlock and click

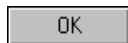

RSLinx browses the network and returns the current device settings.

You see:

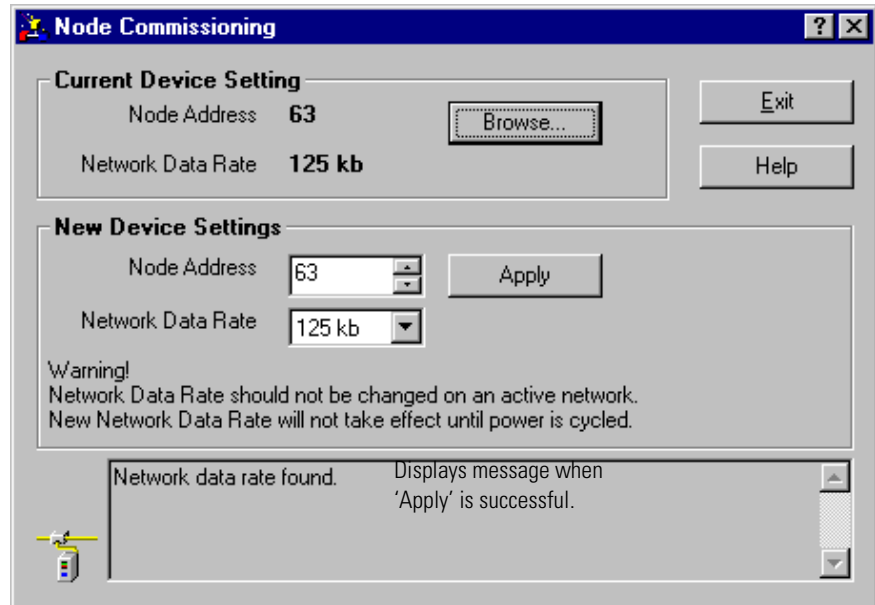

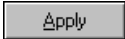
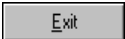
7. Change Node Address to 02, leave data rate as 125 kb and click  and  .

You will see the CompactBlock I/O still at node 63.

8. Click  to browse the network.

You see the CompactBlock I/O at node 02.

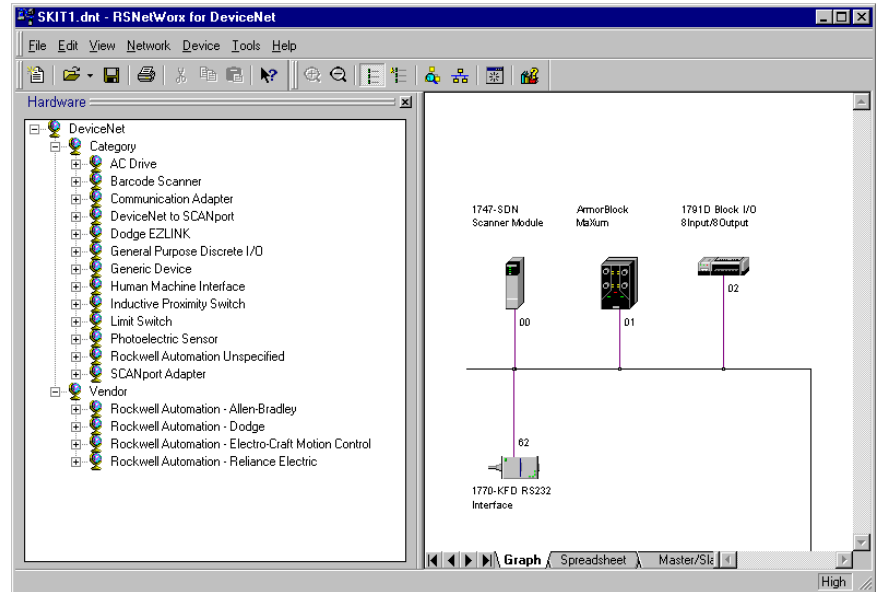

TIP

If your nodes are not in order, press F5 to refresh the window.



9. Save your network file.

When you are node commissioning, you may see a copy of a device with a red X in either RSLinx or RSNetworx. This simply means that RSLinx and RSNetworx can no longer find the device at node address 63. You need to tell RSLinx not to look for that device at node address 63. This “error” will continue to appear until you go to RSLinx and delete the red X copy of the device from the list.

Connect and Commission the ControlTower Stack Light

1. Assemble the ControlTower Stack Light. Refer to the instructions provided with the device. For our demonstration, we placed the red Stack Light on the top and the green on the bottom.
2. Set the node address by hand to 03.

Use tool provided with the ControlTower Stack Light to set these switches and refer to the instructions provided with the device for details.

3. Connect the ControlTower Stack Light to a KwikLink tap.

Your network should look like this:

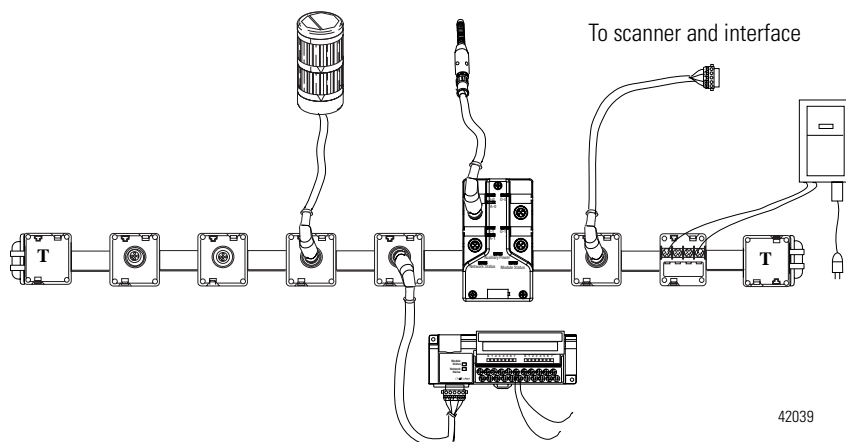

4. You should see a quick blink of each Stack Light when you connect to the network.

Commission the ControlTower Stack Light

5. Go to RSNetWorx and click .

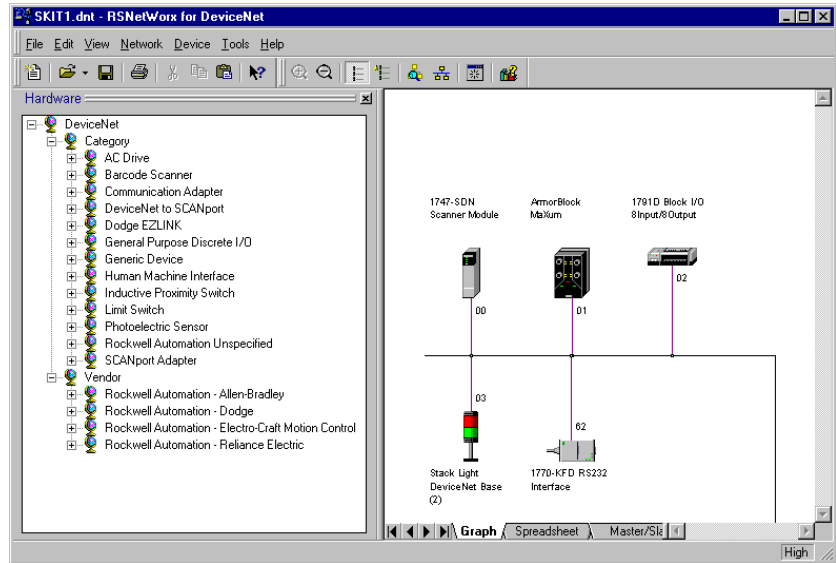

The ControlTower Stack Light automatically displays as node 03.

TIP

If your nodes are not in order, press F5 to refresh the window.



Since the ControlTower Stack Light came up as node 03 when you browsed the network, you don't need to do the Tools/Node Commissioning step. You are done with this device.

6. Save your network file.

Connect and Commission the Inductive Proximity Switch

1. Locate the 90° micro male to micro female cable and connect the female end to the Inductive Proximity Switch and the 90° male end to a KwikLink tap.

Your network should look like this:

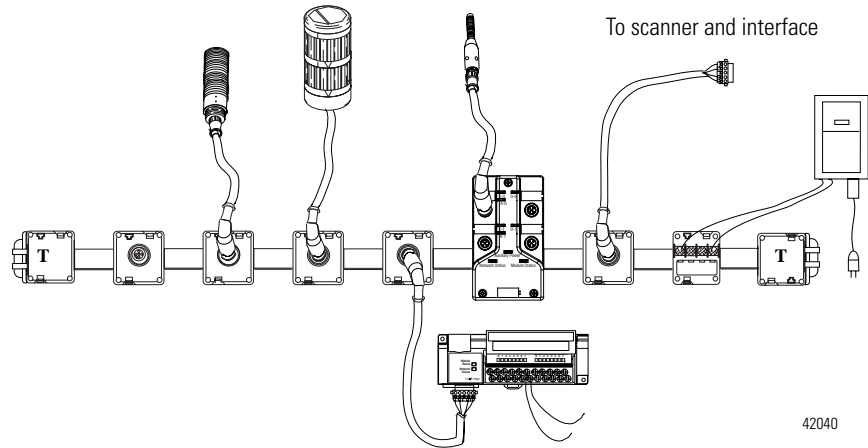

42040

2. Select the “871TM Shielded 18mm with micro” switch in the hardware window and drag it over to your network.

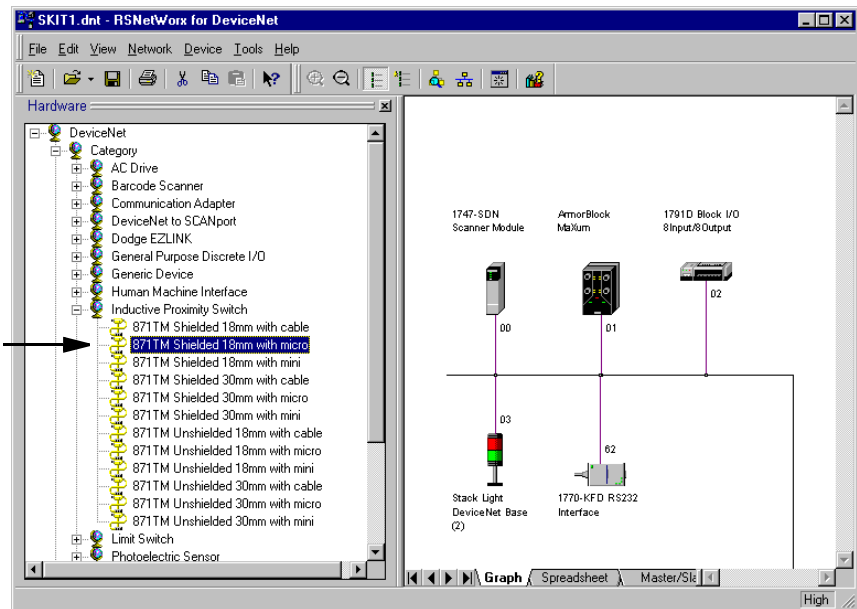

You see:

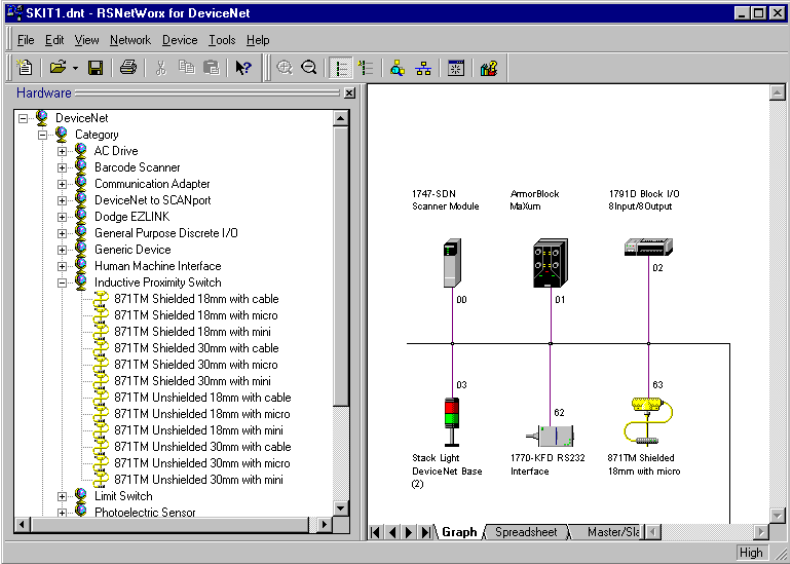

Commission the Inductive Proximity Switch

3. Select Tools/Node Commissioning.



You see:

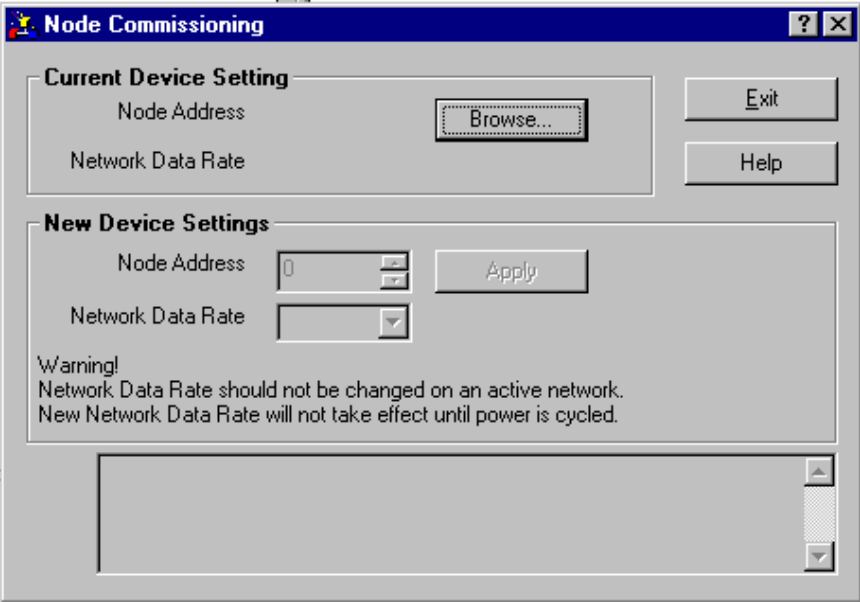

4. Click .

You see:

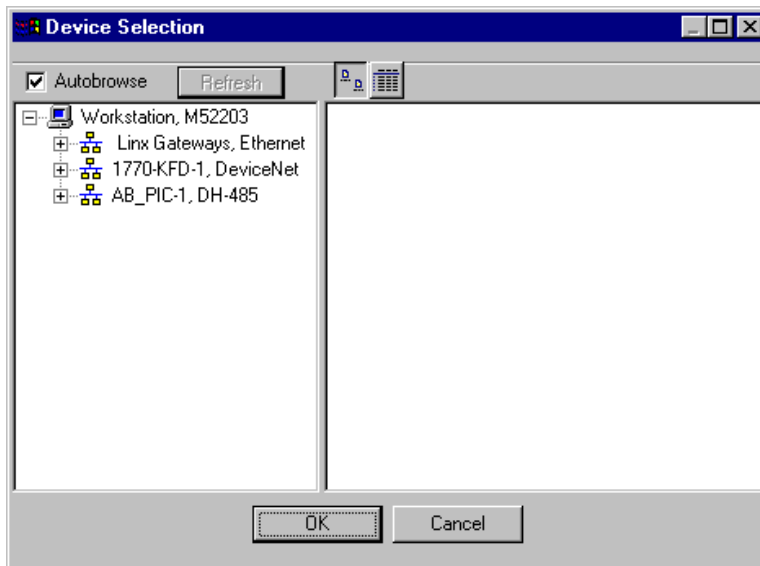

5. Click the + next to your interface. RSLinx returns the current devices on the network.

You see:

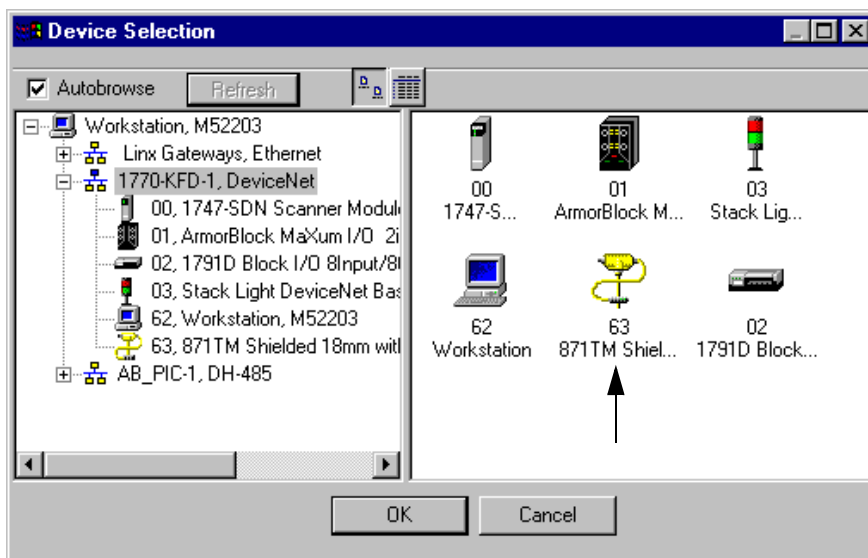

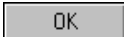
6. Select the Inductive Proximity Switch at node 63 and click .

RSLinx browses the network and returns the current device settings.

You see:

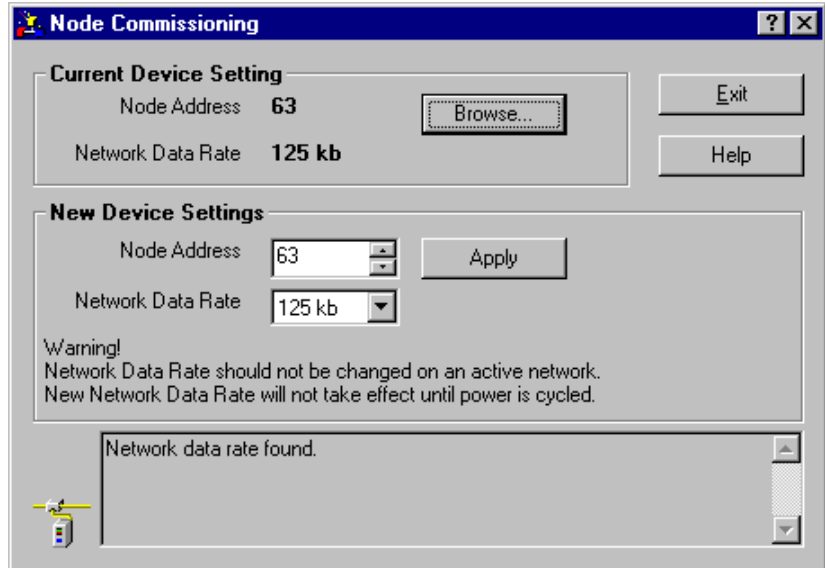

7. Change Node Address to 04.

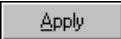
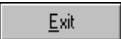
8. Click  and  .

You will see the Inductive Proximity Switch still at node 63.

9. Click  to browse the network.

You see the Inductive Proximity Switch at node 04.

If they are not in order, press F5 to refresh the display.

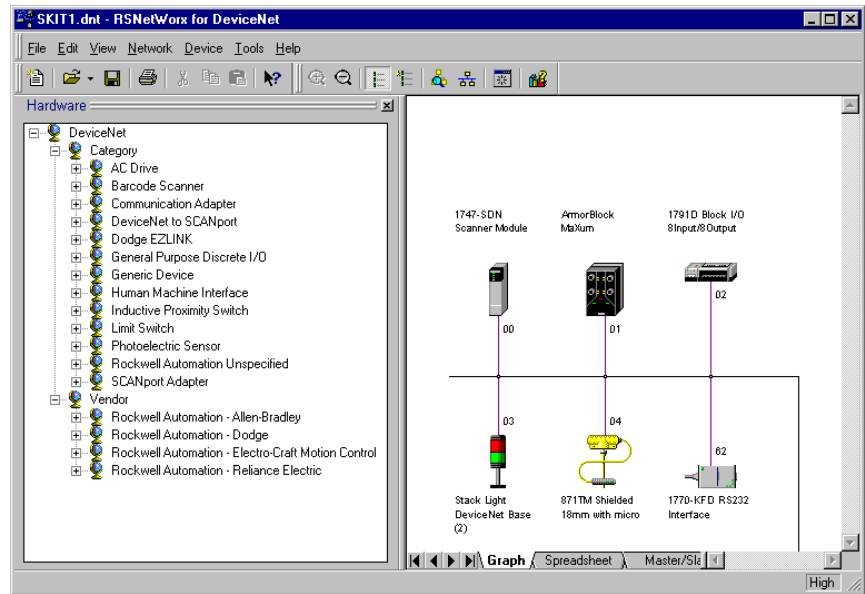

10. Save your network file.

Connect and Commission the RightSight Photoelectric Sensor

1. Locate a 90° micro male to micro female cable and connect the female end to the RightSight Photoelectric sensor and then the 90° male end to a KwikLink tap.

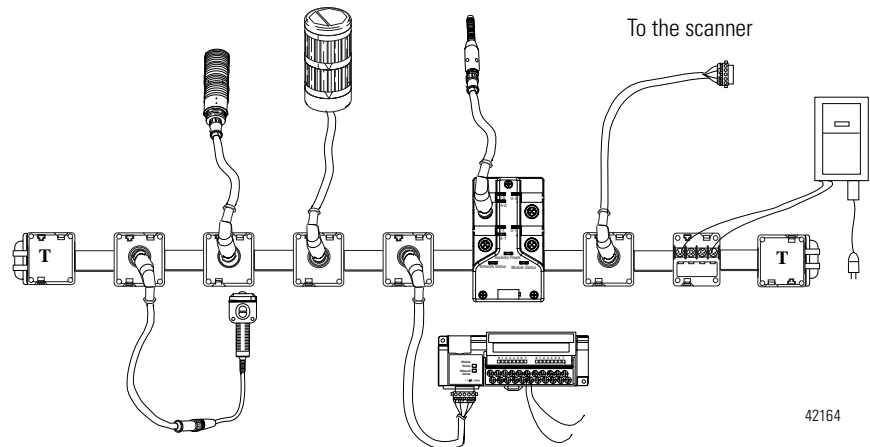

Commission the RightSight Photoelectric Sensor

2. Select Tools/Node Commissioning.

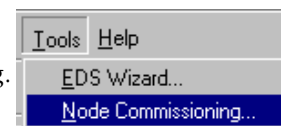

You see:

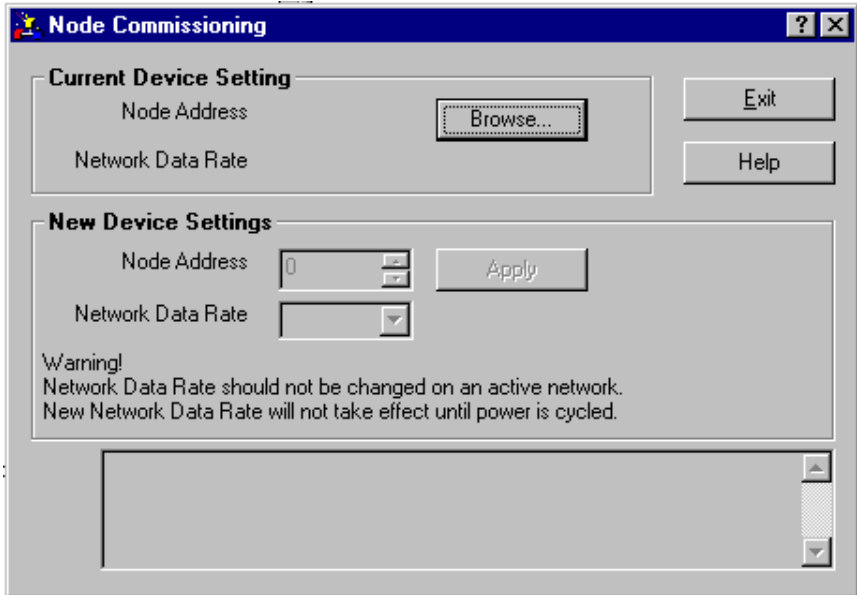

3. Click .

You see:

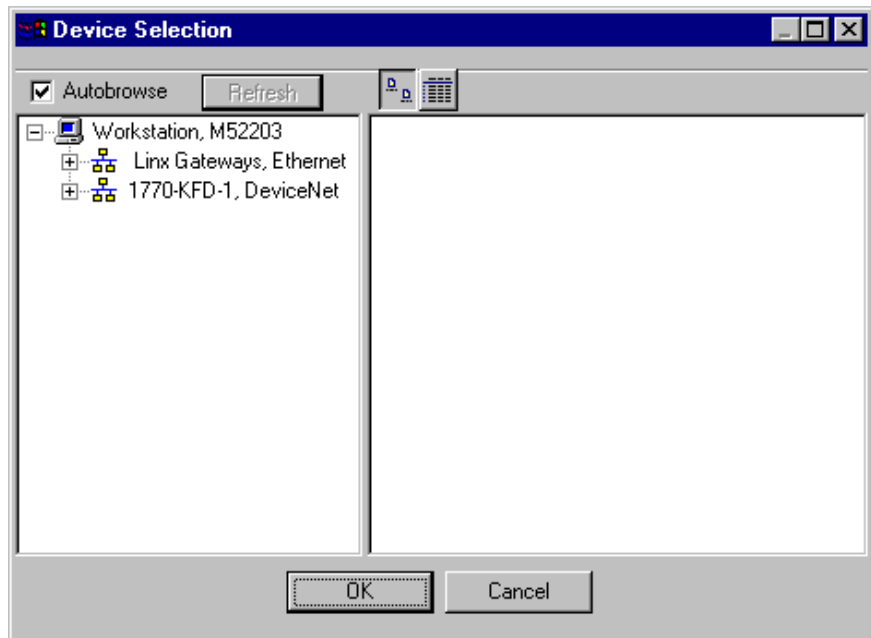

4. Click the + next to your interface. RSLinx returns the current devices on the network.

You see:

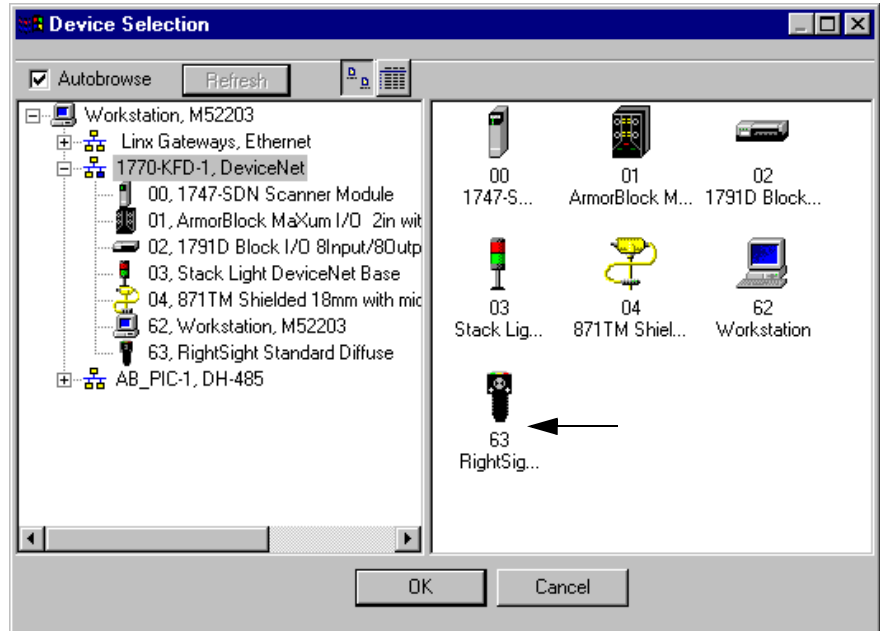

5. Select the RightSight Photoelectric Sensor and click .

RSLinx browses the network and returns the current device settings.

You see:

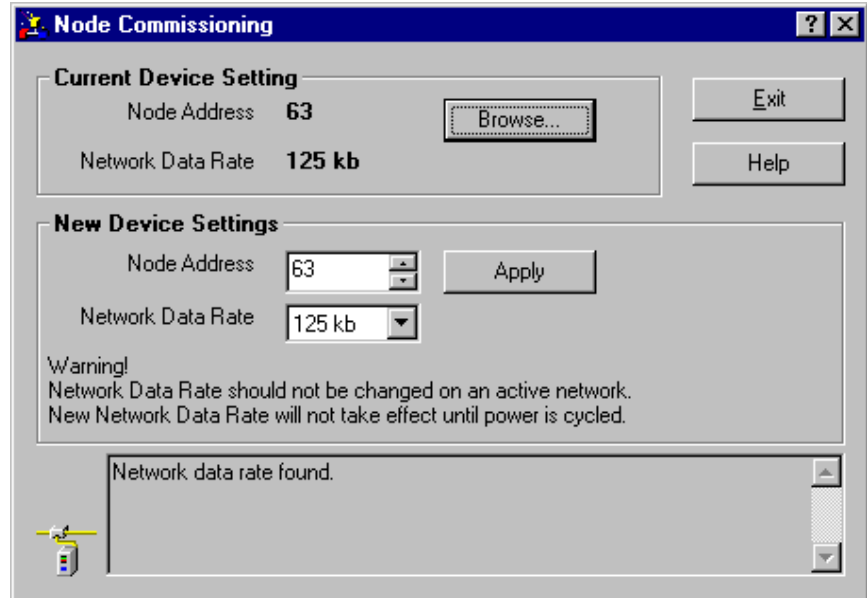

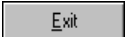
6. Change Node Address to 05 and click  and .

You will see the RightSight Photoelectric Sensor still at node 63.

7. Click  to browse the network.

You see the devices and node addresses updated.

If they are not in order, press F5 to refresh the display.

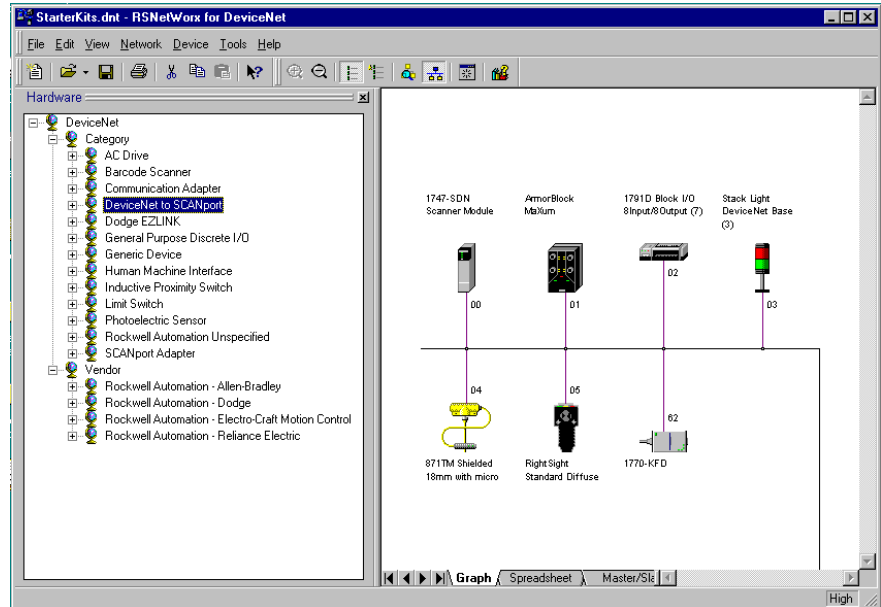

8. Save your network file.

You now have all the devices of your Starter Kit connected and commissioned. At this point, in the real world, you would configure each device for your application. For the Starter Kits we provide an RSNetworx for DeviceNet (.dnt) network configuration file which has the scanlist created and the devices mapped. We also provide associated Rockwell Software ladder logic programming file for each Starter Kit.

What Your Network Will Look Like in RSNetWorx

Use the illustration below to see how your DeviceNet network will look after you connect and commission all the devices. Your device descriptions may be different.

SKIT1

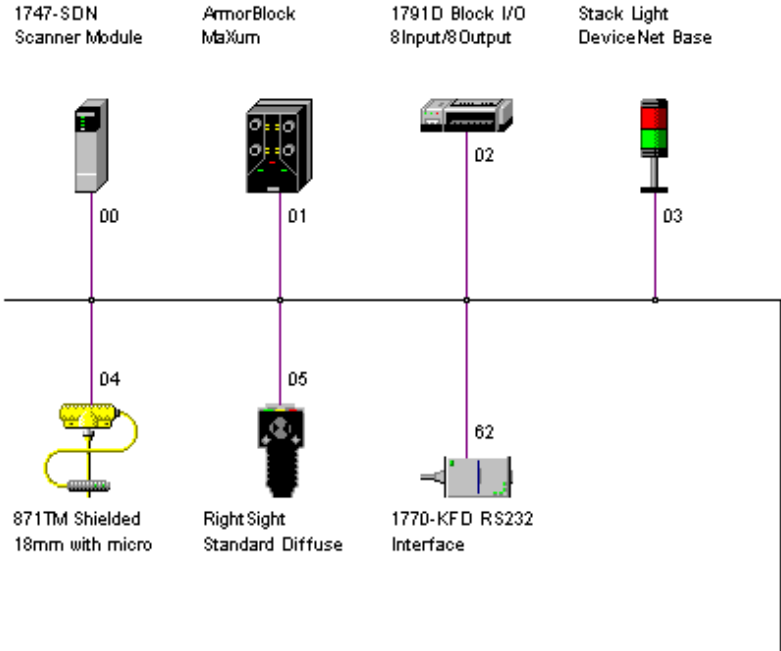

SKIT2

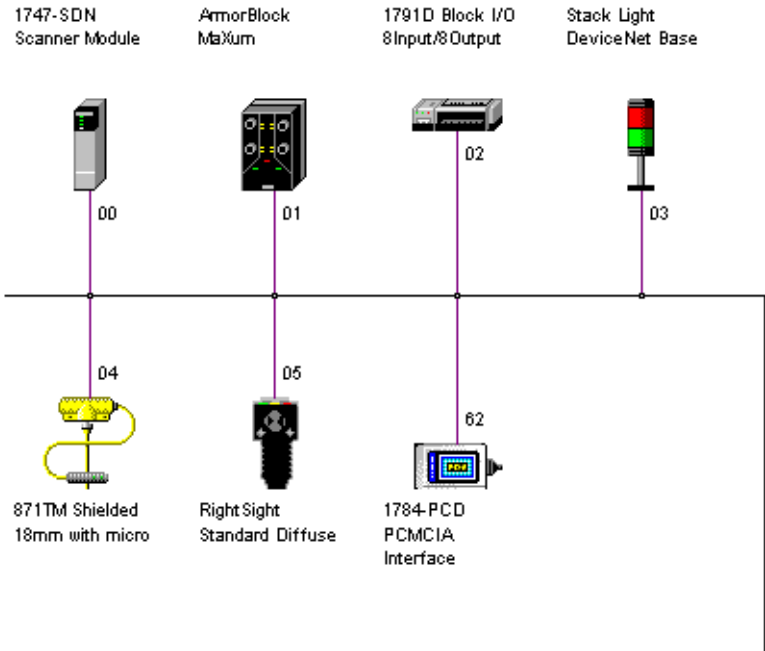

SKIT3

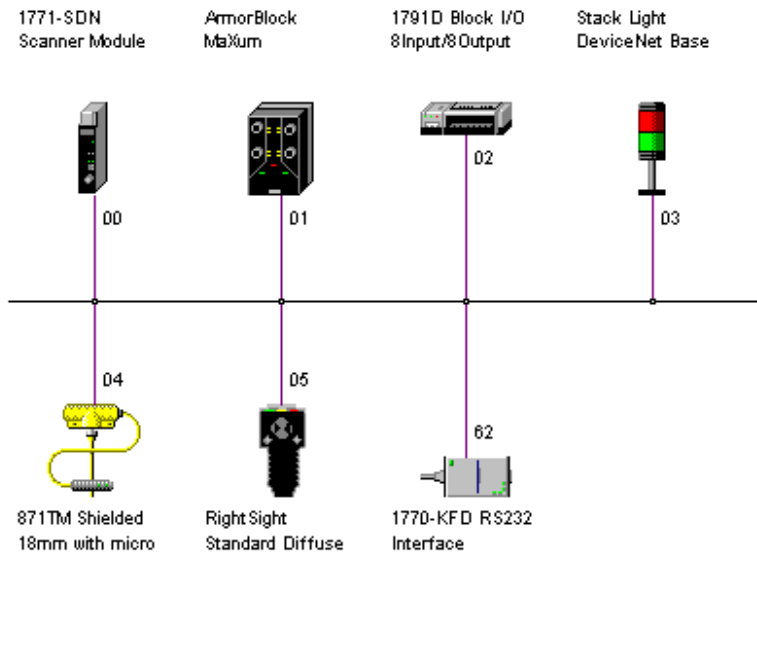

SKIT4

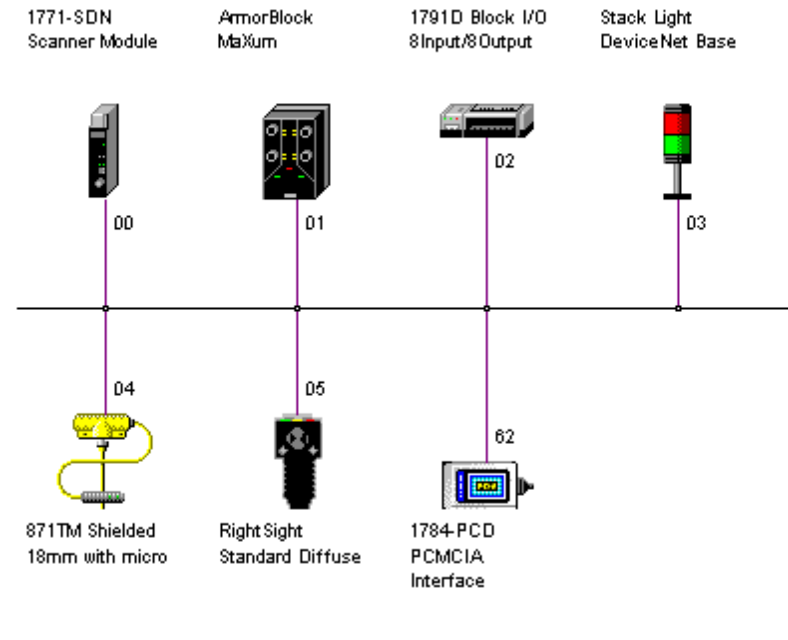

SKIT5

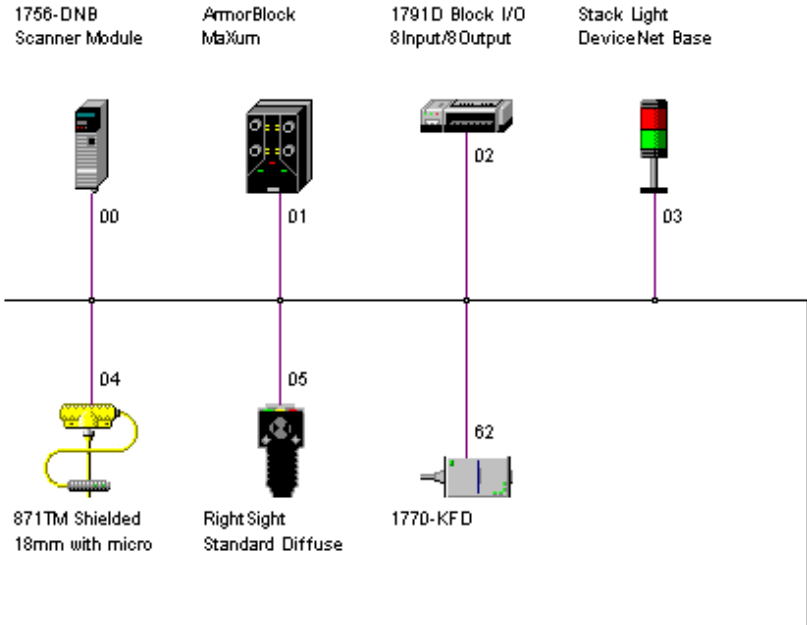

SKIT6

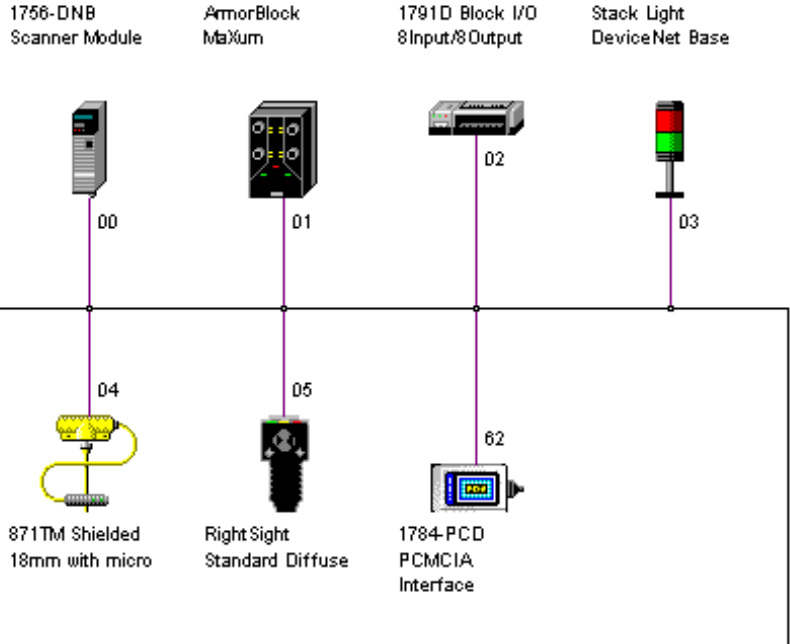

SKIT7

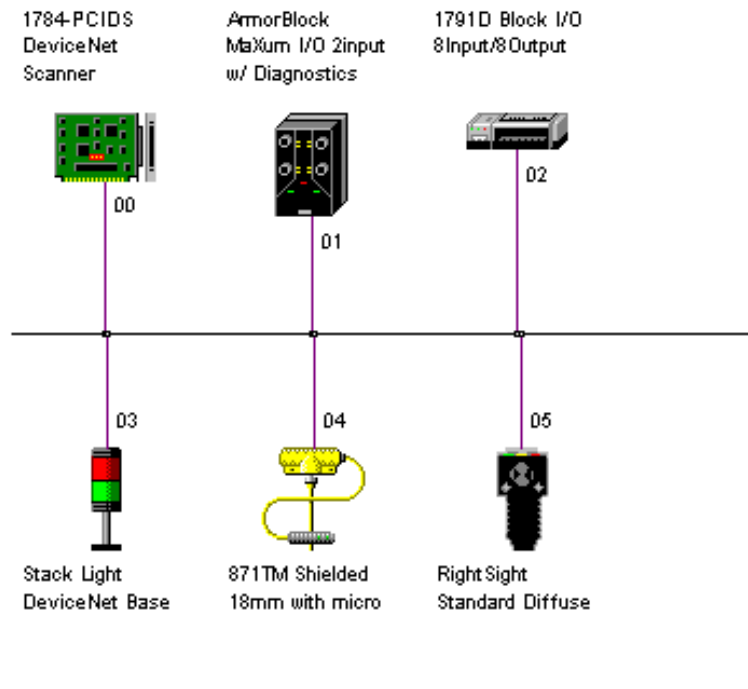

If You Use the Provided .dnt File

We provide the file SKIT1.dnt on the floppy disk. You can use this file to commission your network. After you connect your devices and configure your interface you can open this file and browse the network. If there are any errors you might see a screen like this.

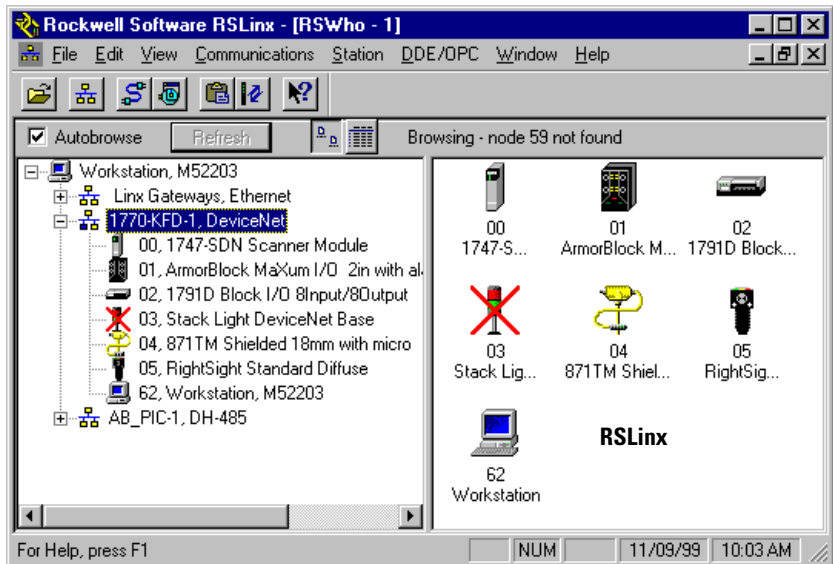
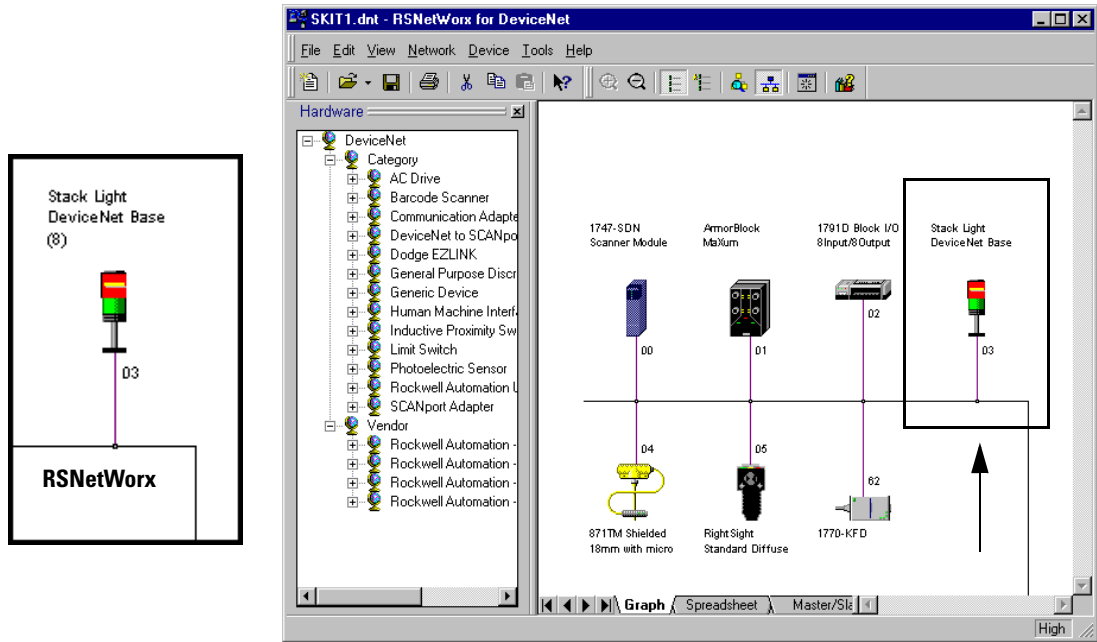

When you see this error message (red block with a yellow line in the center in RSNetWorx or a Red X in RSLinx), the device shown is either offline or it is not connected to the network. If

you no longer wish to have the software look for that device at that address, select the device and delete it.

To fix the error, you would need to:

- check device connections
- re-browse your network
- close the software, re-power your network, and go online
- re-commission the devices
- if the above does not solve your problems, start the Starter Kit process over. If that does not work, contact your Rockwell representative.

You can use the provided file, but we recommend that you follow the step by step instructions provided so you can gain practical experience using the media and software.

Edit the Properties (not required)

1. Right mouse click on the ArmorBlock MaXum icon on the network and you see:

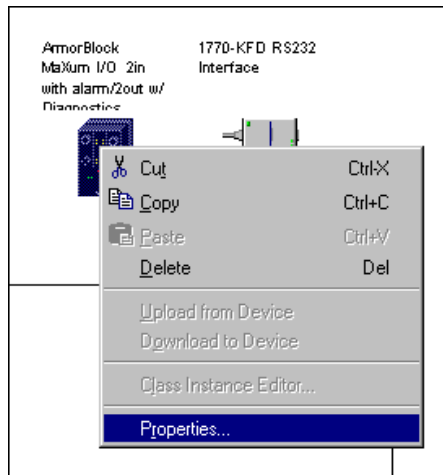

2. Click Properties to edit the properties of the ArmorBlock MaXum you just placed on your network.

You see:

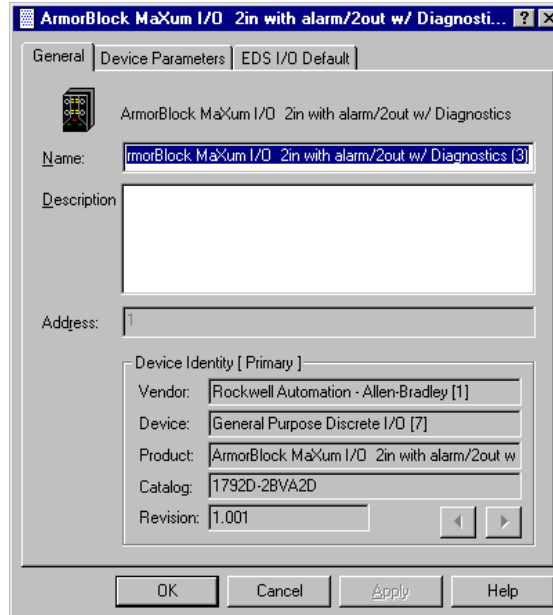

3.Change the name to “ArmorBlock MaXum” (or other name you desire).

4.Add “Standard Proximity Switch” (or other description) to the description field.

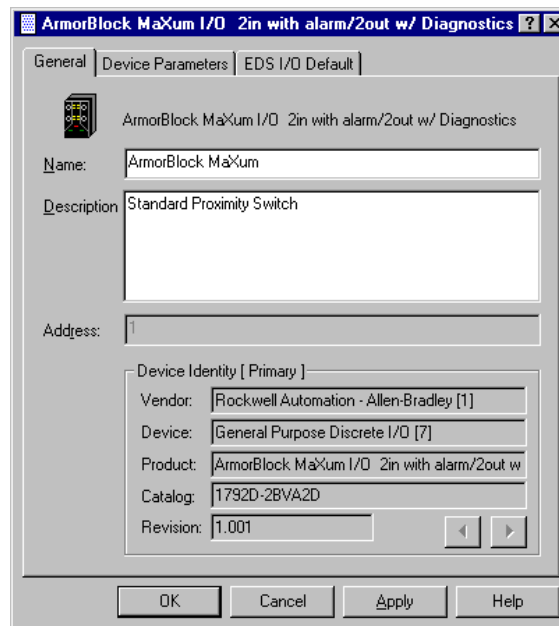

5.Click  and  for the changes to take effect.

You return to the main project screen. Notice that the ArmorBlock MaXum I/O name has changed.

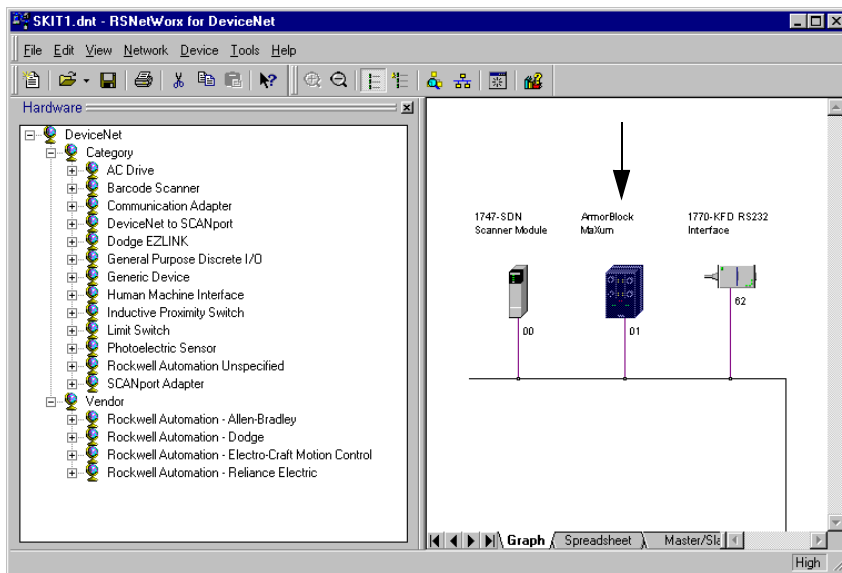

6. Place the cursor over the ArmorBlock MaXum icon on the network diagram.

You see the device description that you entered appear at the lower left-hand corner of the screen.

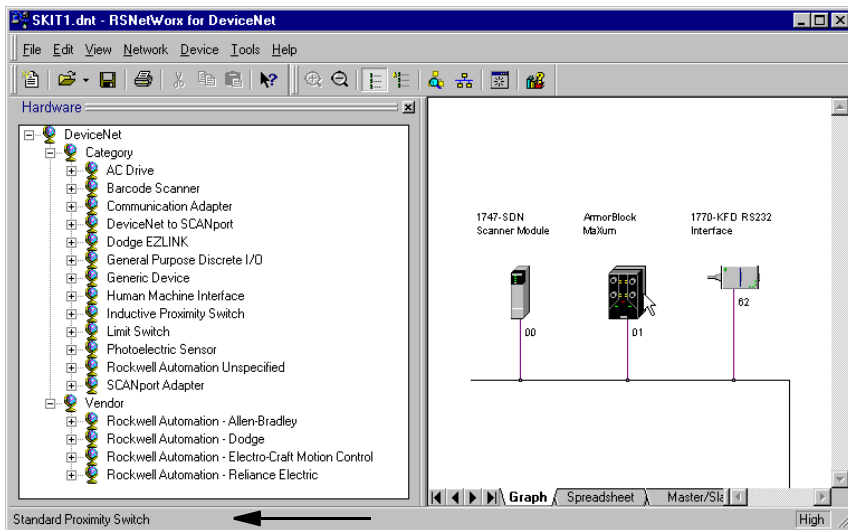

7. Save your network file.

Summary and What's Next

In this chapter, you:

- connected devices
- commissioned nodes
- viewed your network

Move on to Chapter 4 to:

- open the .dnt provided with your Starter Kit
- review the automap function
- build the scanlist
- review device parameters
- download the scanlist to your scanner

Notes:

Build the Scanlist

What This Chapter Contains Read this chapter to configure the scanner by building the scanlist. The following table describes what this chapter contains and where to find specific information.

To:	See page:
learn about scanlists	4-2
configure your scanner	4-3
map input devices	4-17
map output devices	4-22

Introduction

With the Starter Kit, you are not required to create a scanlist and map the device input and outputs. You can simply open the provided network file (.dnt) for your Starter Kit and download the scanlist. Everything is already done for you.

If you wish to create your own scanlist and map your devices to work with the provided ladder logic, follow the steps in this chapter. If you do not want to create your own scanlist and map the devices, open the file, follow steps on pages 4-3 through 4-5 and go to Chapter 5.

For the Starter Kits, we first automapped all the scanlist devices, next we made a few minor adjustments to the word allocations and made only one change to the I/O parameters of one device. The Inductive Proximity Switch I/O parameters have been changed from Change of State/Cyclic to Strobed. This allows the switch to send an analog value.

The ladder logic for each of the Starter Kits programs the devices in exactly the same way. Although, each ladder programming tool uses different addressing schemes and input/output filenames.

What is a Scanlist?

Before a scanner can successfully communicate to the devices on a DeviceNet network, it must first be configured. There are module level parameters and also the scanlist. The scanlist contains all of the information to tell the scanner how to communicate to the devices. The scanner uses the information contained in the scanlist table (SLT) to determine:

- what devices to scan
- how often to scan each device
- what memory locations in the device contain the desired input or output data; and, the size of the data
- the number of bytes to send or transmit (Tx size)
- the number of bytes to receive (Rx size)
- how to communicate with each device (strobed, polled, change of state, cyclic, or any valid combination of these I/O parameters)
- where to map input data and output data so that the processor can read and write it
- how to communicate with the processor (DIO, BTR/BTW, or M1/M0 data transfer)

You can automatically configure most of the data by using the automapping feature of RSNetWorx. This manual describes both manual and automatic mapping procedures.

Configure Your Scanner

For this example we are using SKIT1. If you do not know how to map the device inputs and outputs in relation to where your ladder logic wants to find the devices, simply use the .dnt files provided.

We recommend using the provided files first. Get your network up and running and then go back to the file you created and practice mapping the inputs and outputs as outlined here.

Here's an overview of what you need to do to configure your scanner.

1. Open the SKIT.dnt you created in Chapter 3 or the SKIT.dnt that is provided for your Starter Kit. If you use the file provided the scanlist and I/O mapping is already done for you.
2. Build the scanlist.
3. Edit the I/O parameters of the Inductive Proximity Switch.
4. Map the network inputs and outputs for each device.
5. Review the scanner summary window.
6. Download the software configuration to the scanner.

If You Want to Use the Pre-mapped .dnt File

If you are going to use the provided .dnt file that is already mapped, follow these procedures:

1. Open the SKIT1.dnt (or the file for your SKIT) file, with the scanlist already created and mapped for use with the associated ladder logic file.

2. Click  .

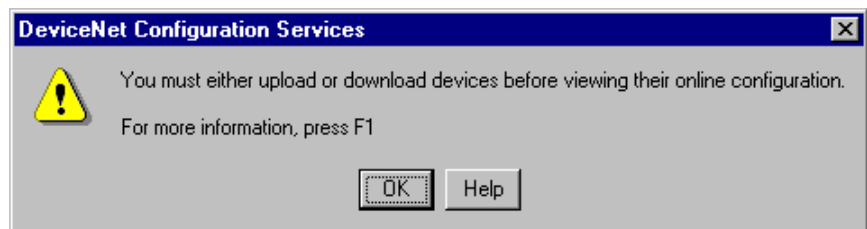

3. Click  .

You see:

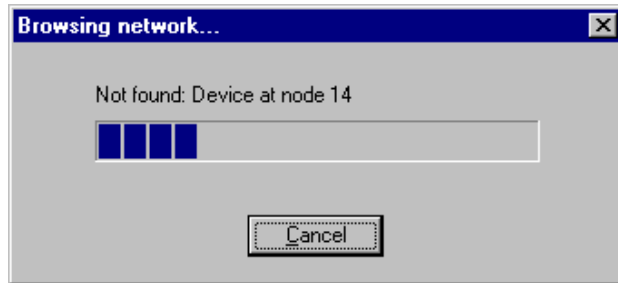

4. Please wait while RSNetWorx is browsing your network.

You see:

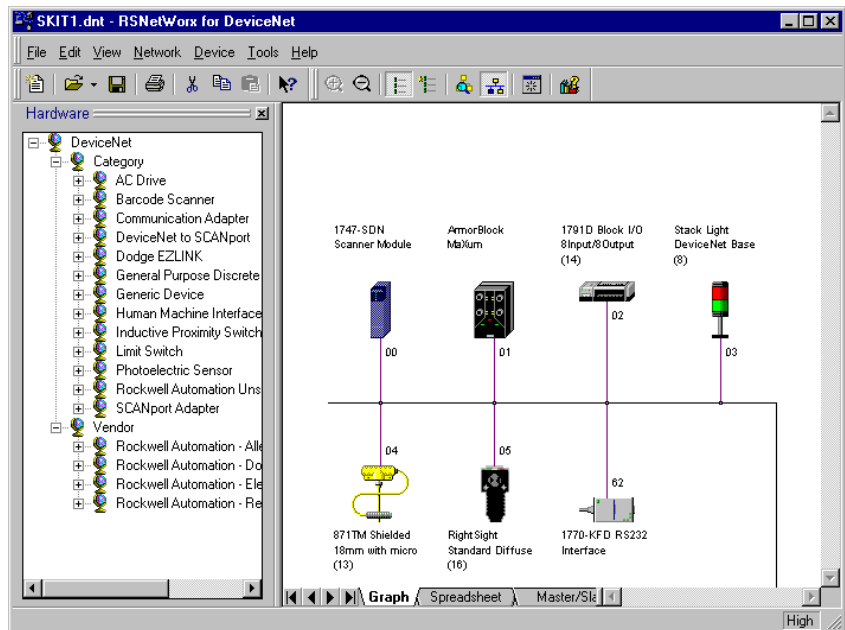

5. Double-click the scanner (node 00) on your DeviceNet network to display the Properties dialog box. (You can also right click on the device to bring up a menu and then choose Properties).

You see:

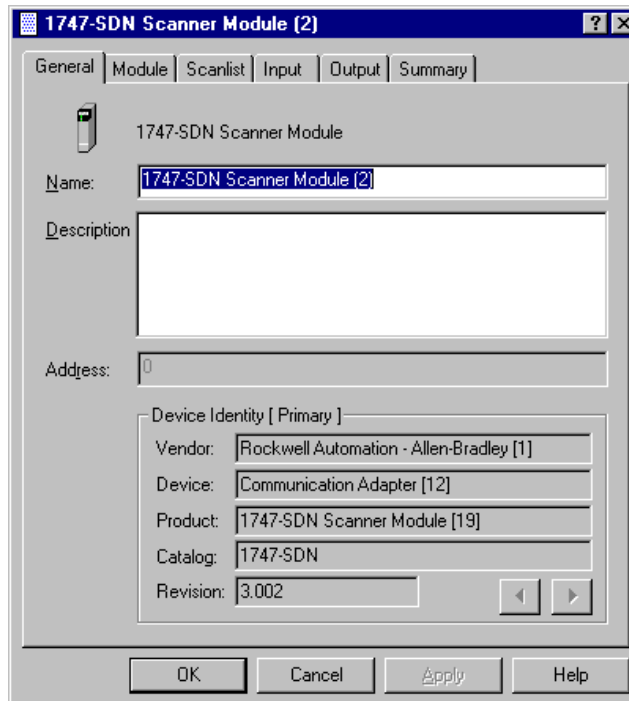

In Properties, you build the scanlist to include the devices that will be scanned on the network.

6. Click the Scanlist tab at the top of the screen.

You see:

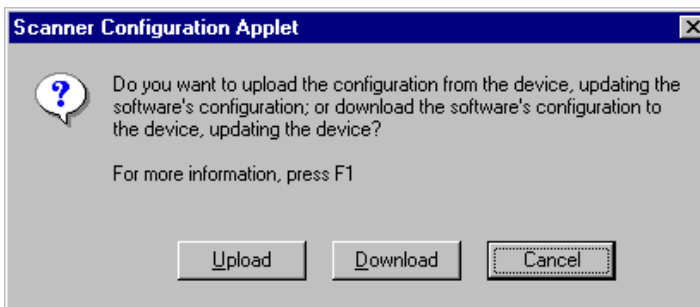

7. Click . This sends the scanlist from the provided .dnt file to the scanner.
8. Go to Chapter 5.

If You Want to Use the .dnt File You Created in Chapter 3

If want to create your own scanlist and map the inputs and outputs, you can either start from scratch by selecting File/New and going online to display your network or you can use the file you created in Chapter 3, follow these procedures:

1. In RSNetWorx, open the your .dnt file. If you are going to start from scratch (File/New), you would click  to display your network.
2. Double-click the scanner (node 00) on your DeviceNet network to display the Properties dialog box. (You can also right click on the device to bring up a menu and then choose Properties)

You see:

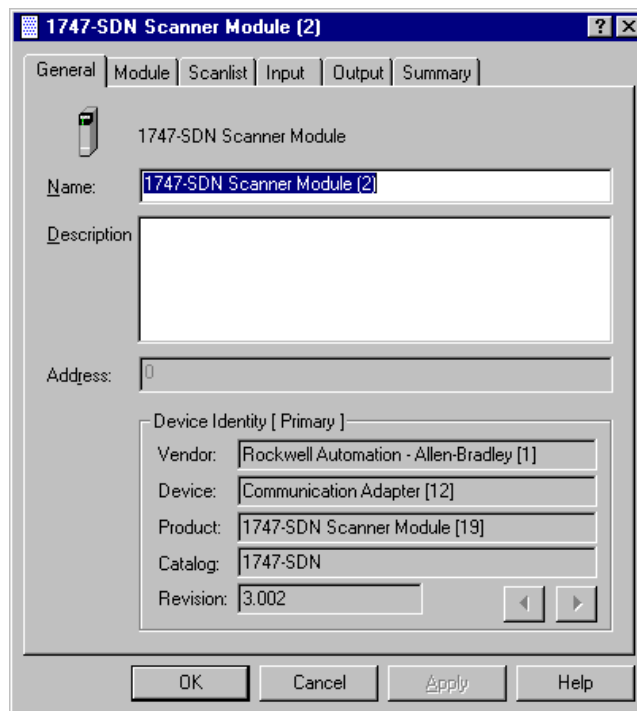

In Properties, you configure the scanlist to include the devices that will be scanned on the network.

3. Click the Scanlist tab at the top of the screen.

You see:

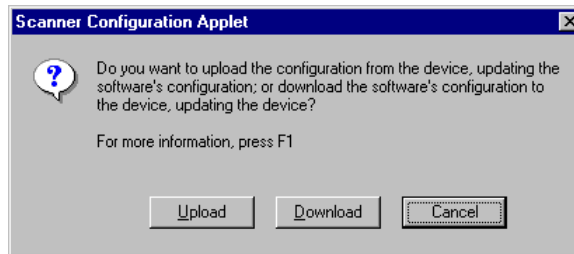

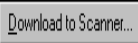
4. Click . This sends the current information about your network from the scanner to the software.

You see:

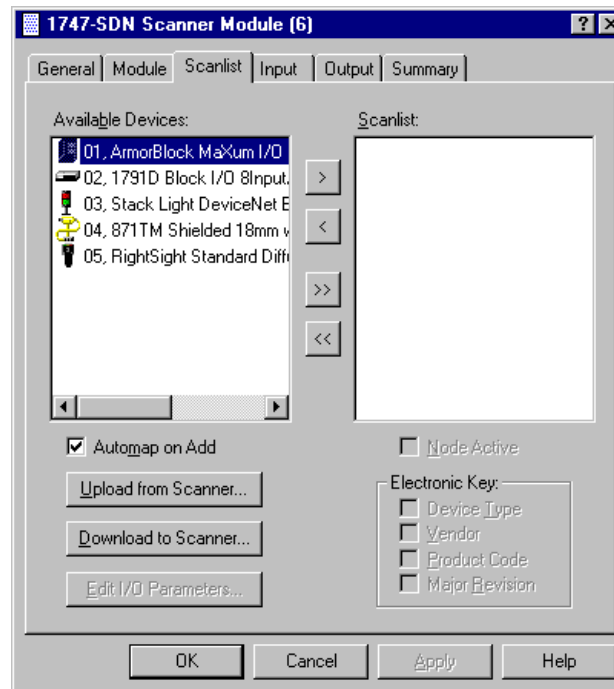

Notice that the **Automap on Add** is checked. This means that once you have added your devices to the scanlist and downloaded, RSNetWorx will automatically map the devices based on the current

EDS file. We are going to automap these devices then edit the input and output mapping positions.

5. Click on  to add all devices to the scanlist at once.

When all devices are added to the scanlist you see:

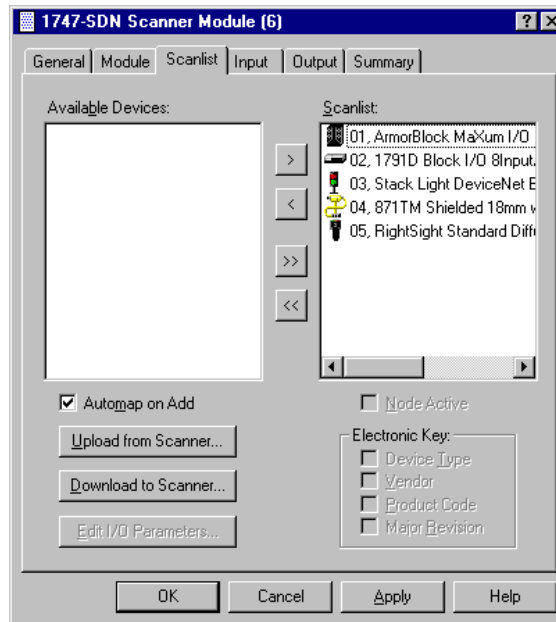

Notice the Electronic Key area of the window.



When the Electronic Keys are checked, RSNetWorx will remember what version of the device you are adding to the scanlist as well as I/O mapping. This is helpful when you need to be certain that a particular device release is used.

The Electronic Keys could be a limitation when you need to replace a device and the device you receive from your vendor is a different

version. Your scanlist will error because the scanner will be looking for a different version of the device.

6. In the scanlist window, hold down the Shift Key and click on each device, selecting the whole list.
7. Click Device Type.

The Electronic Key will deactivate for all devices.

8. Click .

You see:

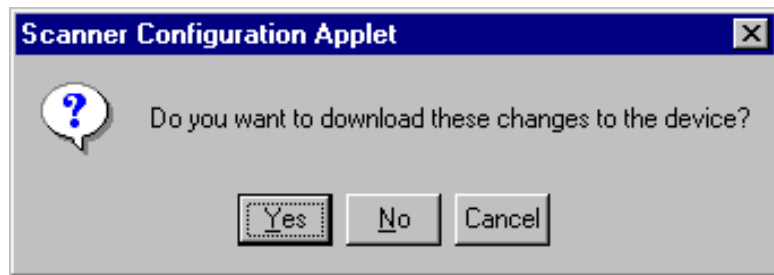

9. Click  to download the scanlist to the scanner.

You see:

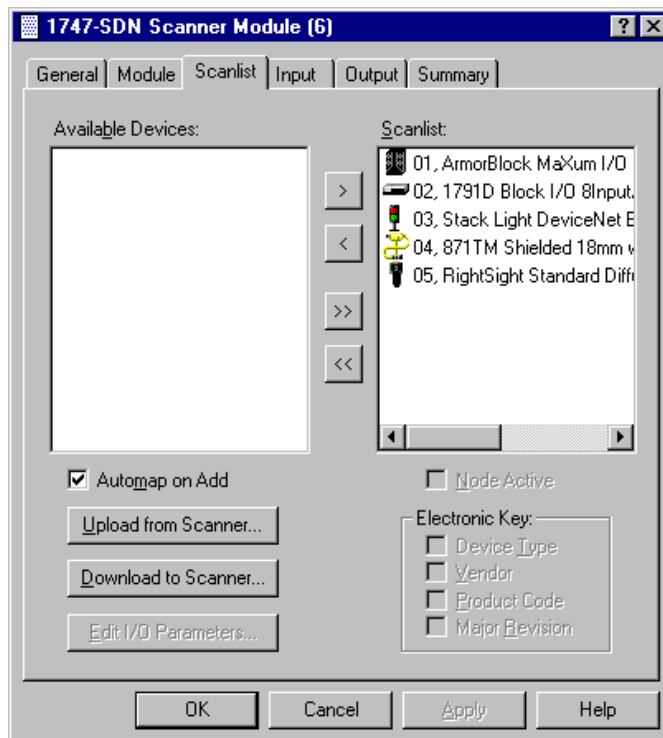

The scanlist is now automapped. Let's take a look at how the inputs and outputs were automapped.

10. Click on the Input tab.

You see:

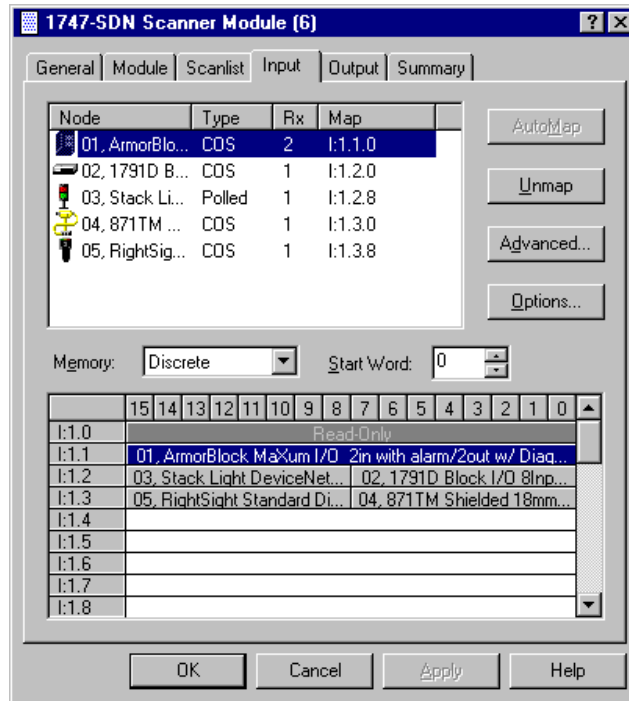

11. Click on the Output tab.

You see:

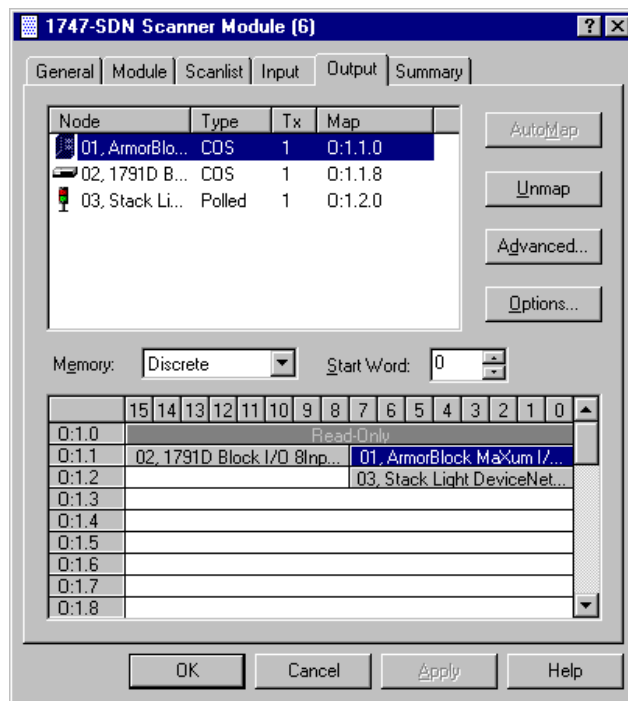

12. Click on the Summary Tab.

You see:

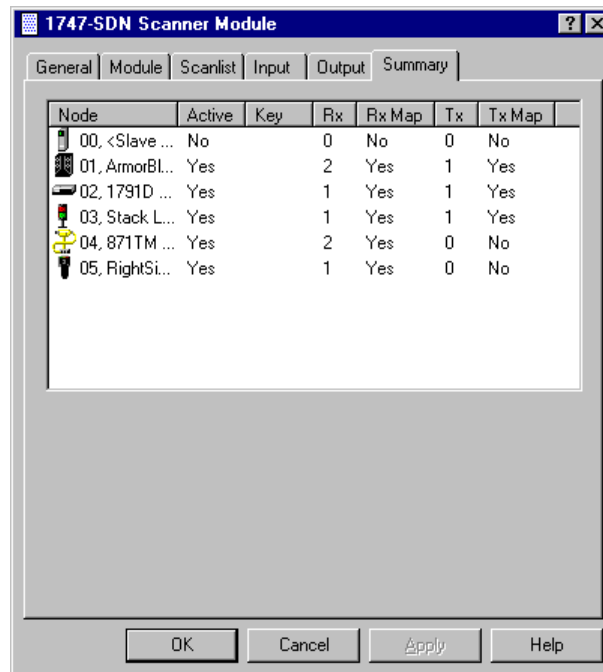

Notice the "Yes" in the Rx Map and Tx Map columns, which is showing that data is currently mapped to and/or from the scanner. In

this Summary, the Key column is blank. If we had checked the Electronic Key a DVP code would appear. This code is used by the scanner to check that the device being communicated to is the correct type. The abbreviations are:

- D = Device
- V = Vendor
- P = Product
- R = Major Firmware Revision.

The scanner checks for an exact match of certain type, by a certain vendor having a specific firmware revision based on the EDS file definitions.

At this point, you could use the auto mapping locations in your ladder program. Realistically, you will need to modify the mapping locations and change an I/O parameter or two.

Let's go ahead and modify the automappings to match the provided ladder logic mapping references.

Edit I/O Parameters for the Inductive Proximity Switch

Change the I/O Parameters to accept strobed messages. This is the only device that will have a parameter change.

1. Double-click the scanner (node 00) on your DeviceNet network to display the Properties dialog box. (You can also right click on the device to bring up a menu and then choose Properties).

You see:

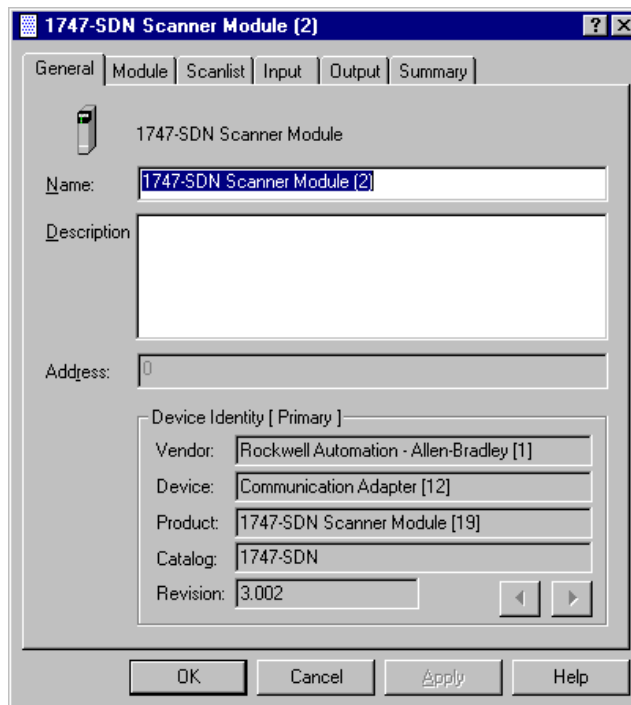

2. Click the Scanlist tab at the top of the screen.

If you see:



you will want to upload the scanlist from the scanner to get the correct device information.

1. You see..

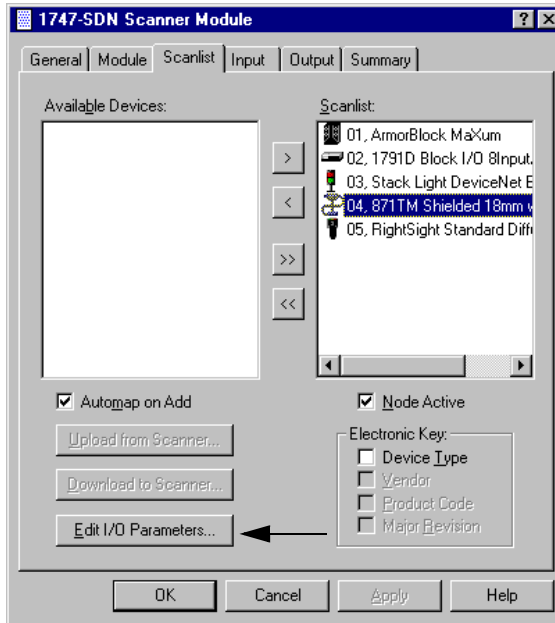

1. Select the Inductive Proximity Switch and click Edit the I/O parameters
2. Check Strobed and change the Rx size to 2.
3. Uncheck Change of State/Cyclic.

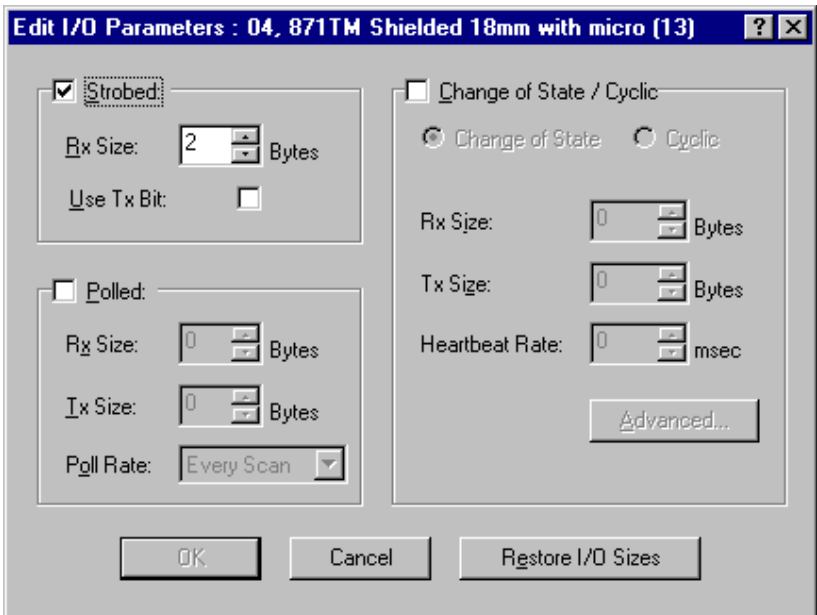

4. Click OK.

You see:

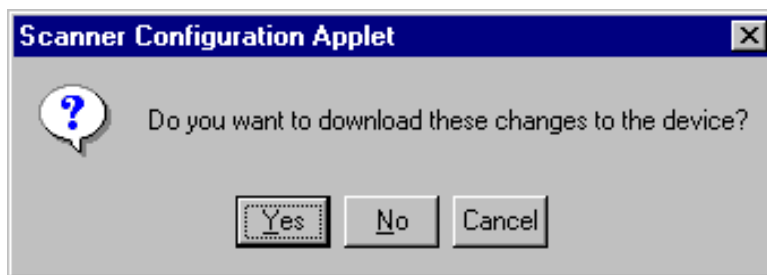

5. Click to download the scanlist to the scanner.

Map Input Devices

This screen shows how the inputs are mapped when RSNetWorx automapped. Once you have edited the I/O Parameters for the Inductive Proximity Switch, you will notice that the switch has taken up all of word three and removed the RightSight Photoelectric Sensor.

SKIT1 Inputs automapped

SKIT1, for example:

- The ArmorBlock MaXum needs the two bytes of word 1.
- The ControlTower Stack Light needs to be mapped to the high byte of word 2.
- The CompactBlock needs to be mapped to the low byte of word 2.
- The Inductive Proximity Switch needs the two bytes of word 3.
- The RightSight Photoelectric Sensor needs to be mapped to the low byte of word 4.

You will need to unmap the RightSight and the Inductive Proximity Switch and then remap.

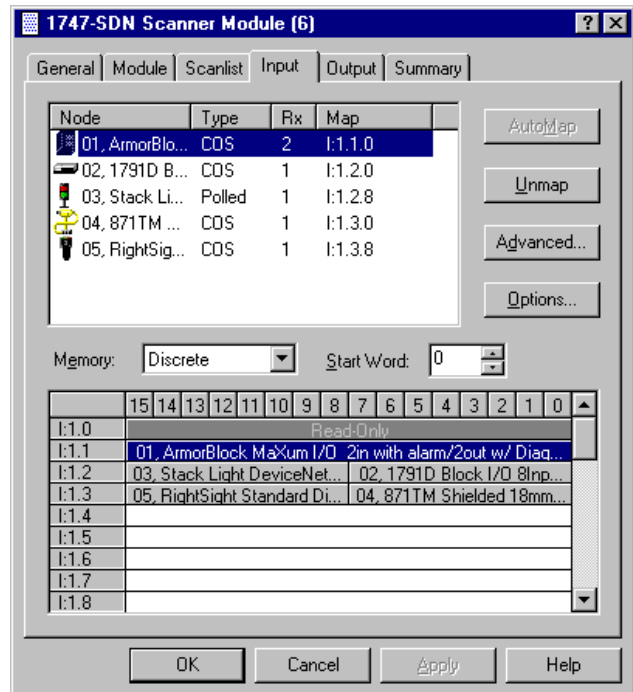

The following are the modified Input mapping windows for each of the Starter Kits. If you are going to map these devices to use with the provided ladder logic you must be exact or the ladder will not run properly.

The steps to modify an automapped input or output word are:

1. Click on the device that you want to change.
2. Click Unmap.
3. Click on the device to map/remap.
4. Look at the example for your Starter Kit and determine the word placement.
For example, the ArmorBlock MaXum needs 2 bytes of word 1.
5. Set the Start Word number where you would like the input to begin.
6. Click AutoMap.
7. Repeat the process until you have mapped all the devices like the example mapping.

SKITs 1 and 2 Inputs Mapped

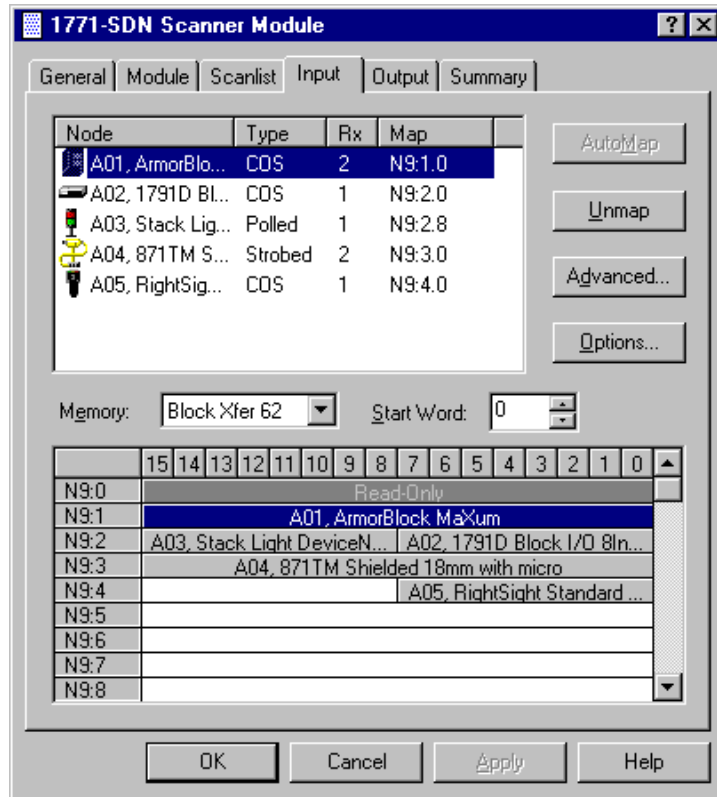

SKITs 3 and 4 Inputs Mapped

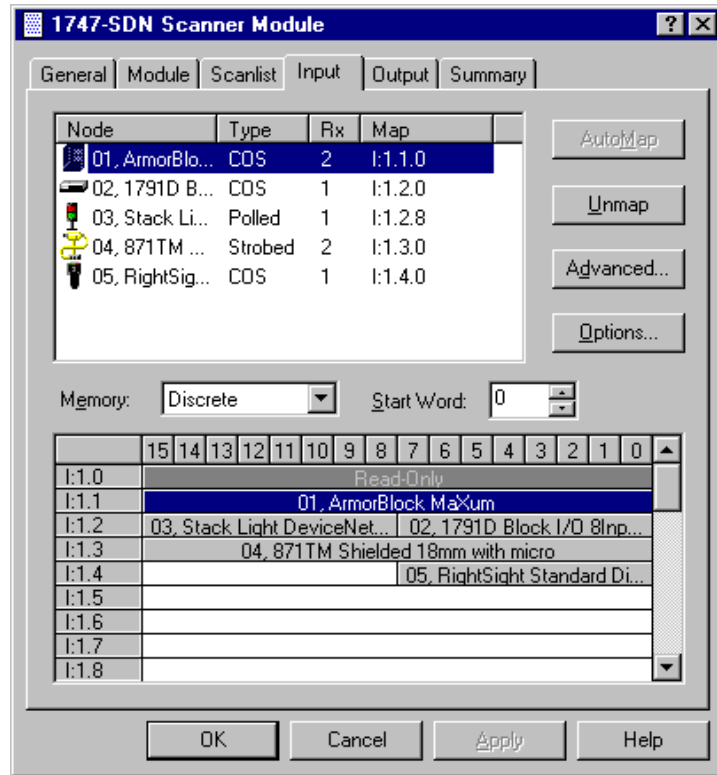

SKITs 5 and 6 Inputs Mapped

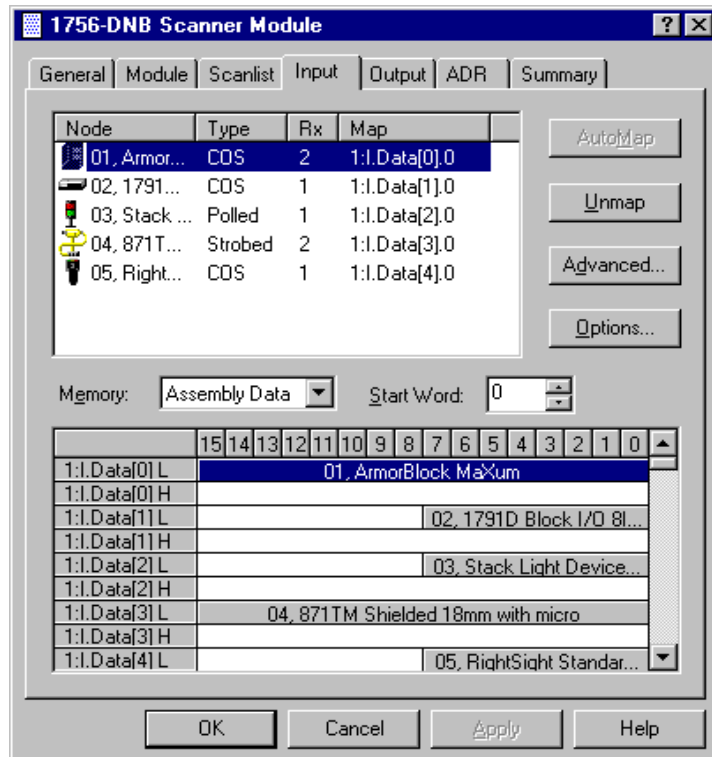

SKIT 7 Inputs Mapped

Map Output Devices

The following screen is how the device outputs are automapped.

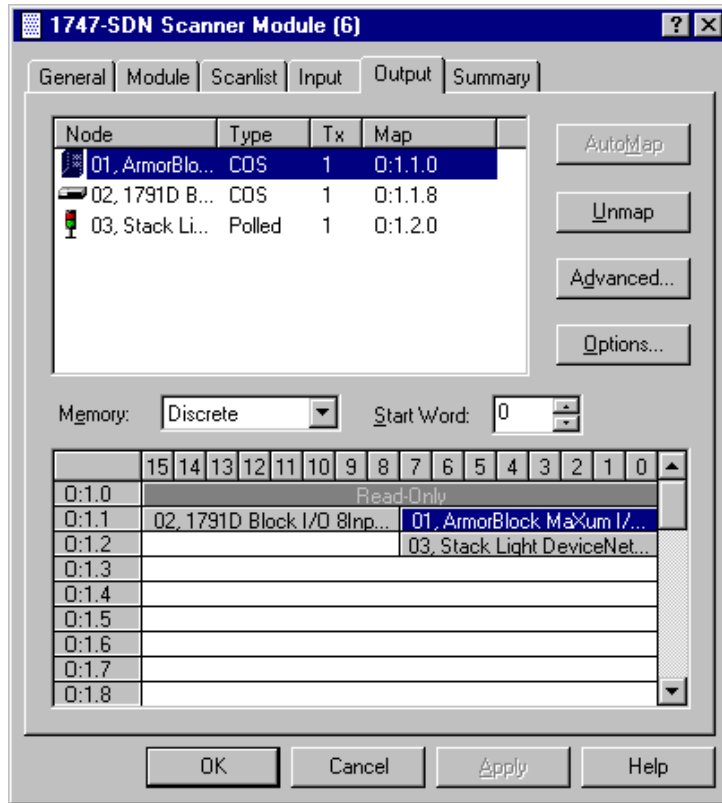

The following are the modified Output mapping windows for each of the Starter Kits. If you are going to map these devices to use with the provided ladder logic you must be exact or the ladder will not run properly.

The steps to modify an automapped input or output word is:

1. Click on the device that you want to change.
2. Click Unmap.
3. Click on the device to map/remap.
4. Look at the example for your Starter Kit and determine the word placement.
5. Set the Start word number where you would like the input to begin.
6. Click AutoMap.
7. Repeat the process until you have mapped the devices like the example mapping.

SKITs 1 and 2 Outputs Mapped

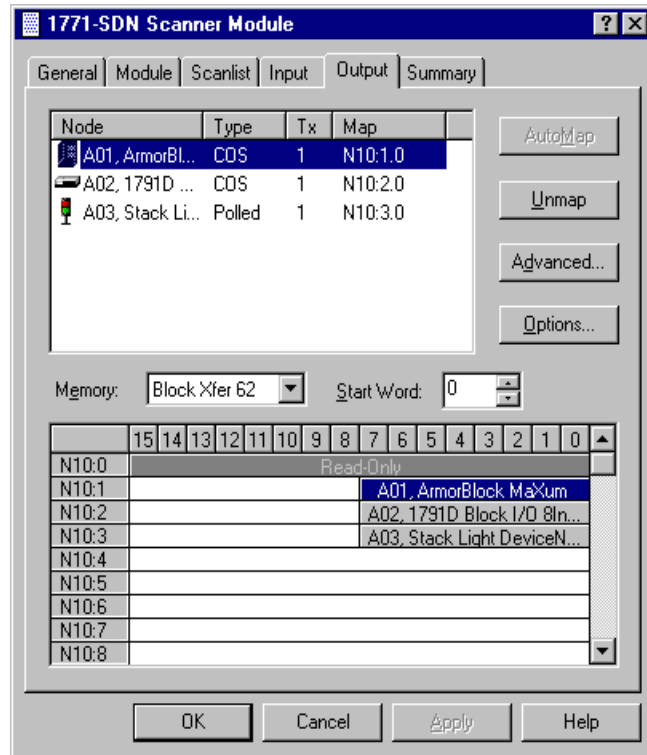

SKITs 3 and 4 Outputs Mapped

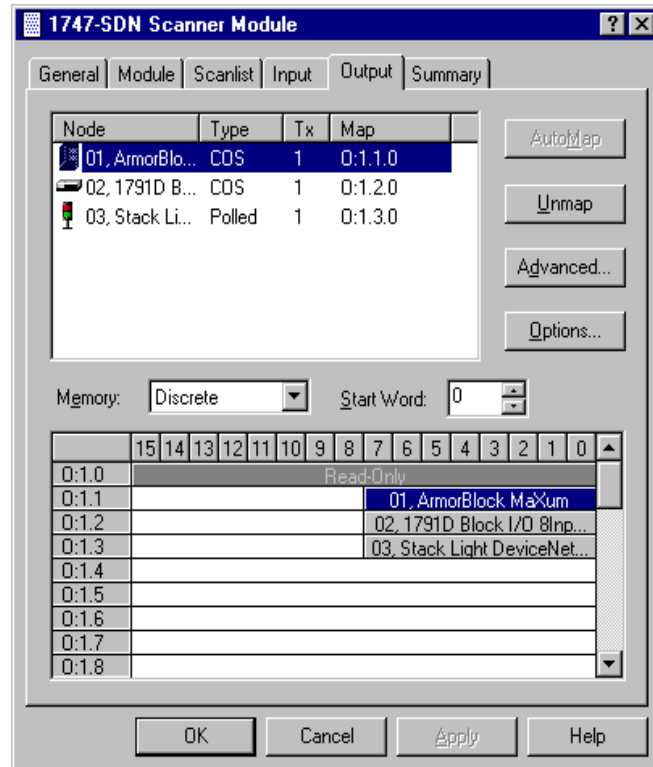

SKITs 5 and 6 Outputs Mapped

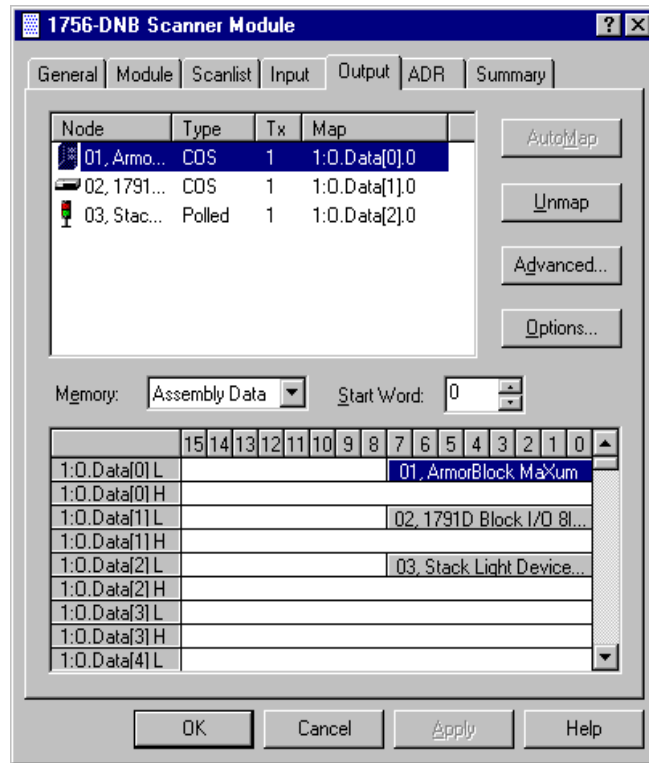

SKIT7 Outputs Mapped

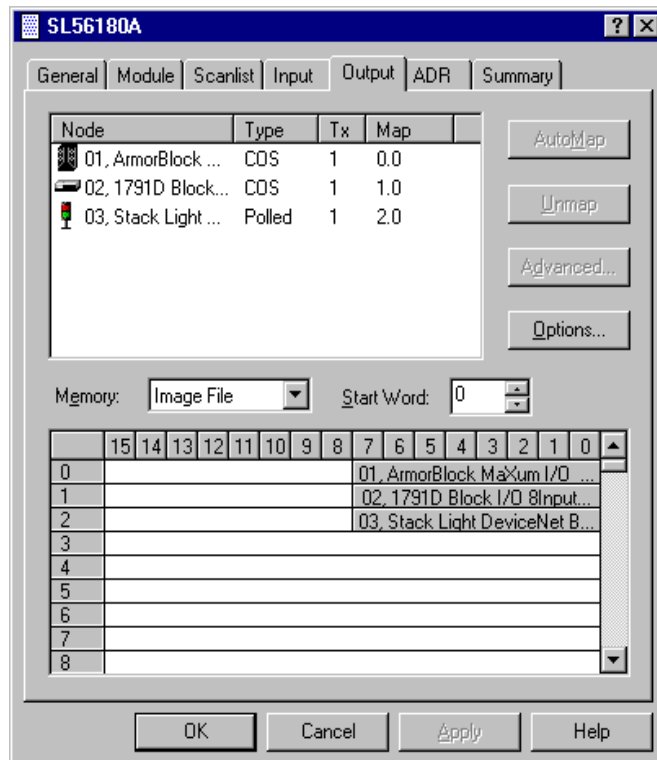

Notes:

RSNetWorx for DeviceNet Starter Kit Demonstration

What This Chapter Contains

Read this chapter to use the RSNetWorx for DeviceNet demonstration network files and ladder logic programs provided for your Starter Kit. The following table describes what this chapter contains and where to find specific information.

To:	See page:
review what the demonstration does	5-1
determine what files to use with your Starter Kit	5-2
run the demonstration	5-3
monitor I/O data	5-8

What Does the DeviceNet Starter Kit Demonstration Do?

The sample RSNetWorx network file (.dnt) is the configuration of the devices that are contained in your Starter Kit. The ladder logic program (.rss, .rsp, .acd) provides a way for the devices to communicate with the scanner and to perform basic functions or react to a trigger.

The results of the network configuration and ladder logic are:

- When you place your hand in front of the **RightSight Photoelectric Sensor** the processor (the location of the ladder logic) tells the scanner that the green ControlTower Stack Light needs to illuminate. The scanner then signals the Stack Light to illuminate.
- When you place a metal object in front of the **Inductive Proximity Switch** an analog value is sent to the processor (the location of the ladder logic). The ladder logic monitors the analog data and sends a message to the scanner to turn on the CompactBlock outputs depending on the objects distance from the Inductive Proximity Switch.
- When you place a metal object directly on the **Standard Proximity Switch** connected to the ArmorBlock MaXum I/O, the processor sends a message to the scanner to tell the red Stack Light to illuminate.

If you use your own file that you created earlier for the demonstration, you must follow the instructions accurately when setting node numbers and mapping the inputs/outputs. The ladder logic is written to recognize certain devices at certain node addresses with particular mapping attributes. If the address or mapping does not match what is in the provided ladder, the demonstration won't work properly.

If you are proficient in modifying the mapping and ladder logic feel free to experiment. If you find that you have modified your files and the demonstration won't work, reload and open the provided .dnt and corresponding ladder file and start over.

Files to Use With Your Starter Kit

Starter Kit:	RSNetWorx filename:	Ladder Logic filename:
SKIT1 1747-SDN and the 1770-KFD	SKIT1.dnt	SKIT1.rss RSLogix 500 Version 2.5 Revision 2.57.0.0
SKIT2 1747-SDN and the 1784-PCD	SKIT2.dnt	SKIT2.rss RSLogix 500 Version 2.5 Revision 2.57.0.0
SKIT3 1771-SDN and the 1770-KFD	SKIT3.dnt	SKIT3.rsp RSLogix 5 Release 3.0 Revision 3.22.00.00
SKIT4 1771-SDN and the 1784-PCD	SKIT4.dnt	SKIT4.rsp RSLogix 5 Release 3.0 Revision 3.22.00.00
SKIT5 1756-DNB and the 1770-KFD	SKIT5.dnt	SKIT5.acd RSLogix 5000 Revision 2.10.00
SKIT6 1756-DNB and the 1784-PCD	SKIT6.dnt	SKIT6.acd RSLogix 5000 Revision 2.10.00
SKIT7 1784-PCIDS	SKIT7.dnt	SKIT7.rsp RSLogix 5 Release 3.0 Revision 3.22.00.00

Some of the device descriptions and rung explanations may not display when you open the ladder logic file. Refer to the ladder logic illustrations on pages 5-4 through 5-7 for descriptions and explanations.

Run the Demonstration

Follow these steps to run the demonstration:

1. Follow instructions in Chapters 1-4.

At this point you should have your Starter Kit assembled, powered, commissioned, and configured. RSLinx should be minimized with your scanner, interface and all nodes listed without errors.

2. Locate the floppy disk that came with your Starter Kit.
3. Open your ladder logic programming tool, i.e. RSLogix 500.

You can communicate between your PC and network with RSLogix programming software via any of these mechanisms:

- Serially, to channel 0 of the PLC/SLC
 - DH+ (PLC-5 & SLC-5/04)
 - DH 485 (SLC-5/02, 5/03)
 - Ethernet (PLC-5E, SLC 5/05)
4. ControlNet (PLC-5C, SLC 5/02, 5/03, 5/04, 5/05 w/1747-KFC)
 5. Place the processor in program mode.
 6. Open the ladder logic file (.rss, .rsp, or .acd) for your Starter Kit.
 7. Go online and download the ladder logic program to your processor.
 8. Place the scanner in run mode.
 9. Experiment with the devices.
 - a. Place your hand in front of the RightSight Photoelectric Sensor. The green ControlTower Stack Light illuminates. View the data mapping tables and monitor your inputs and outputs.
 - b. Place the Standard Proximity Switch flush against a metal object. The red ControlTower Stack Light illuminates. View the data mapping tables and monitor your inputs and outputs.
 - c. Place a metal object flush against the Inductive Proximity Switch. The low byte of the CompactBlock I/O output LEDs illuminate. Slowly move the metal object away from the switch. Notice that the LEDs change depending on the distance between the switch and the metal object. This is an analog signal that allows the device to communicate distance. View the data mapping tables and monitor your inputs and outputs.

Ladder Logic for SKITs 1 and 2

Below is the ladder logic for SKIT1 and SKIT2. The files were created in RSLogix 500 Version 2.5, Revision 2.57.0.0. The filenames are Skit1.rss and Skit2.rss.

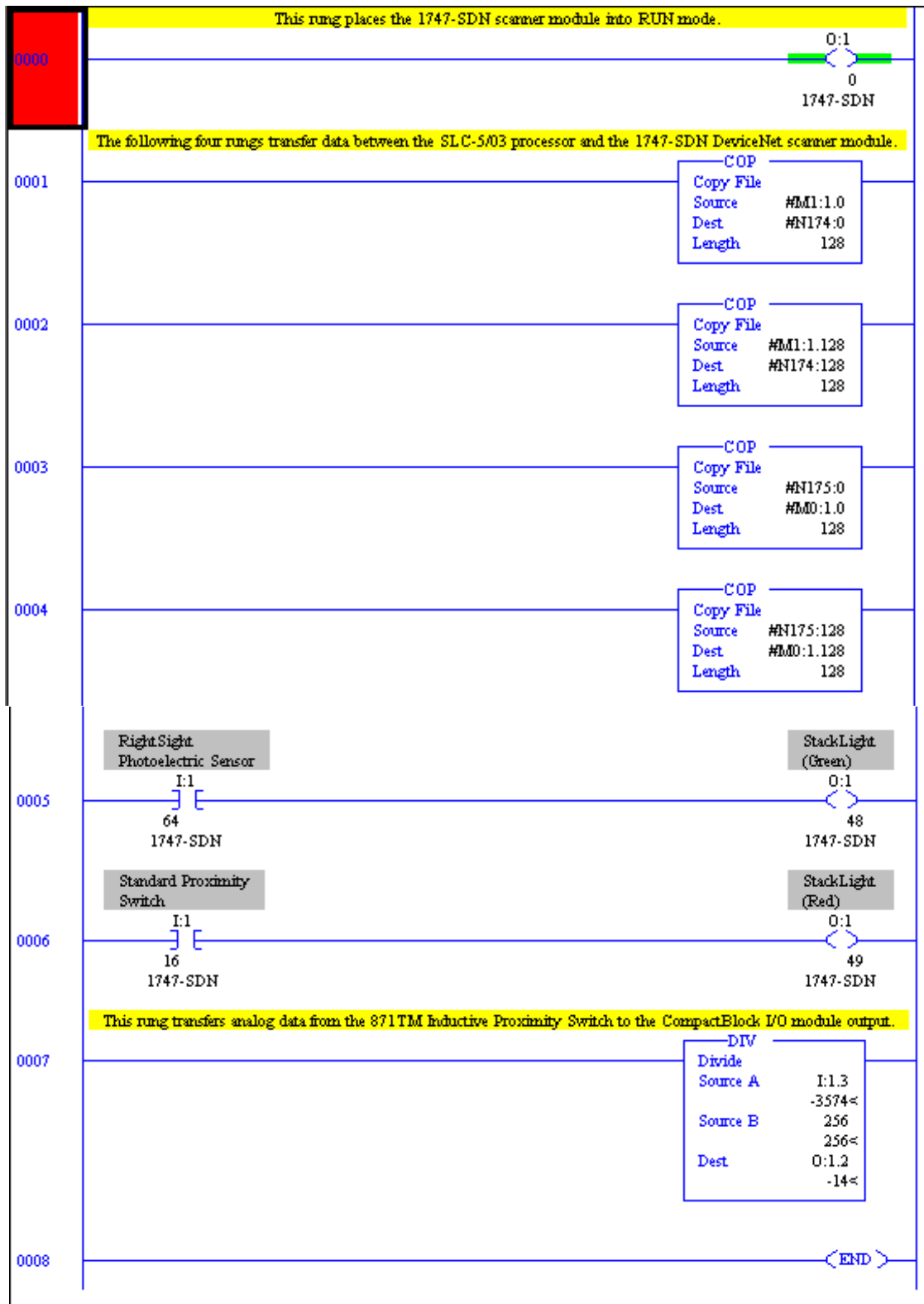

Ladder Logic for SKITs 3 and 4

Below is the ladder logic for SKIT3 and SKIT4. The files were created in RSLogix 5 Release 3.0 Revision 3.22.00.00. The filenames are Skit3.rsp and Skit4.rsp.

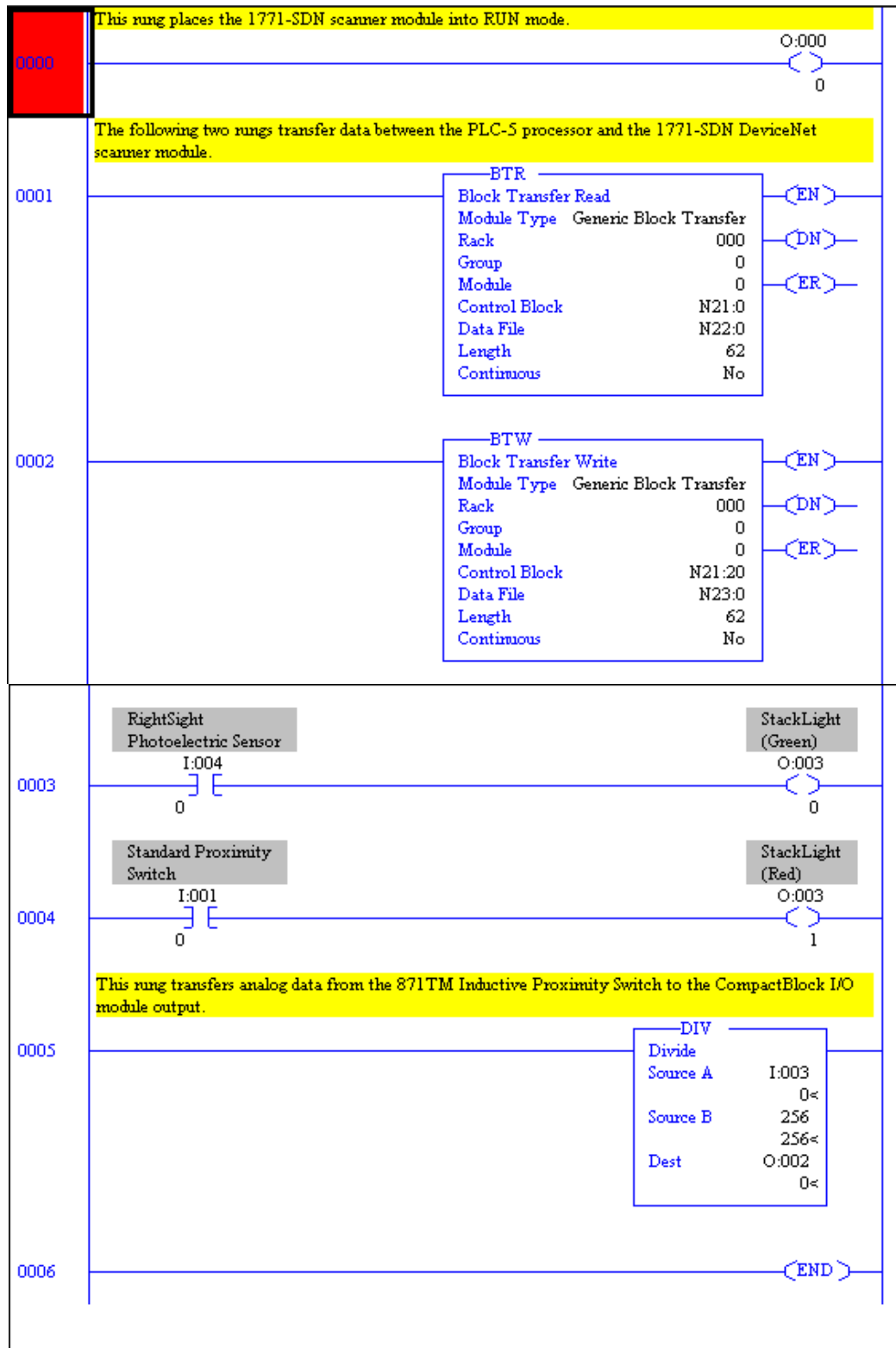

Ladder Logic for SKITs 5 and 6

Below is the ladder logic for SKIT5 and SKIT6. The files were created in RSLogix 5000 Version 2.10.00. The filenames are Skit5.acd and Skit6.acd.

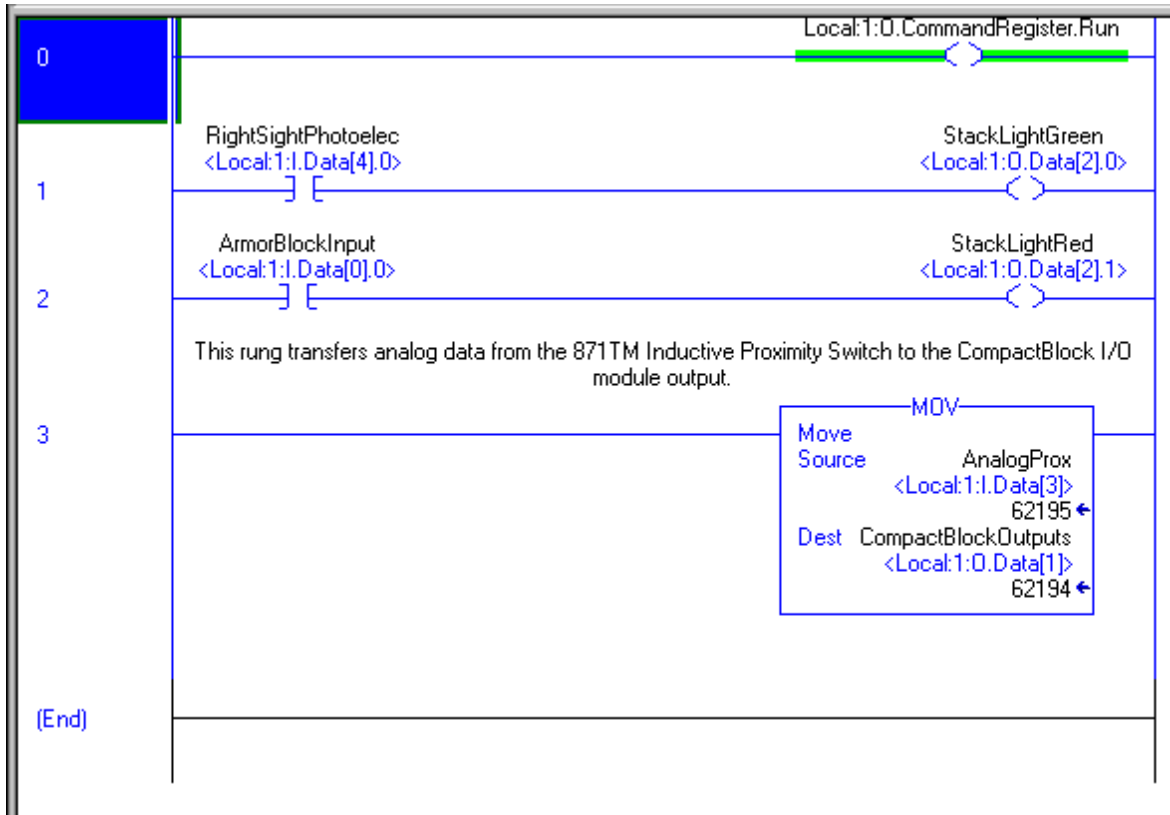

Ladder Logic for SKIT 7

Below is the ladder logic for SKIT7. The file was created in RSLogix 5 Release 3.0 Revision 3.22.00.00. The filename is Skit7.rsp.

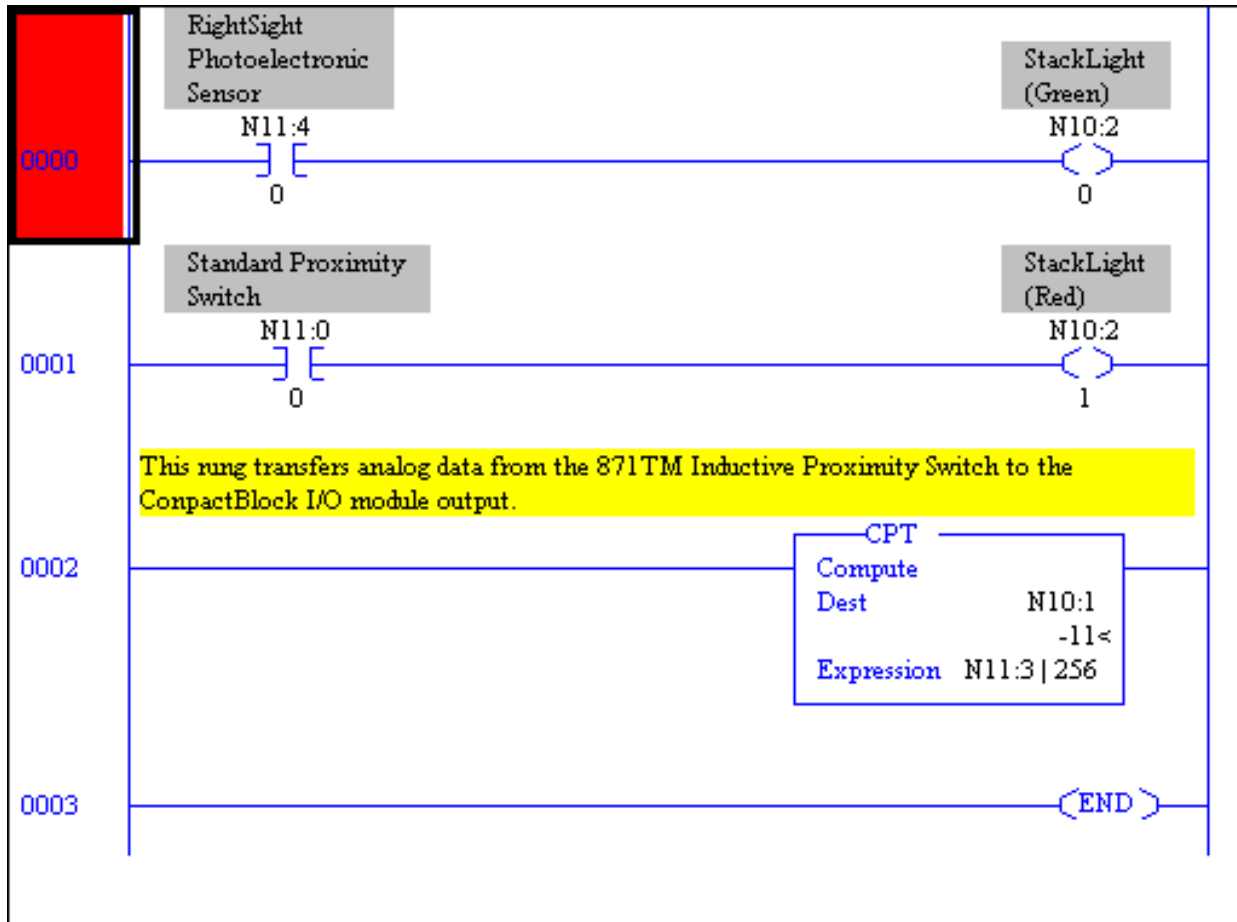

Monitor the I/O Data

The next section of the demonstration uses the ladder logic programming software (RSLogix 500) to go inside the processor to monitor the I/O data for your devices on your DeviceNet network.

1. Start the ladder logic programming software. (i.e. RSLogix 500, 5000, 5)
2. Open the ladder file for your Starter Kit.

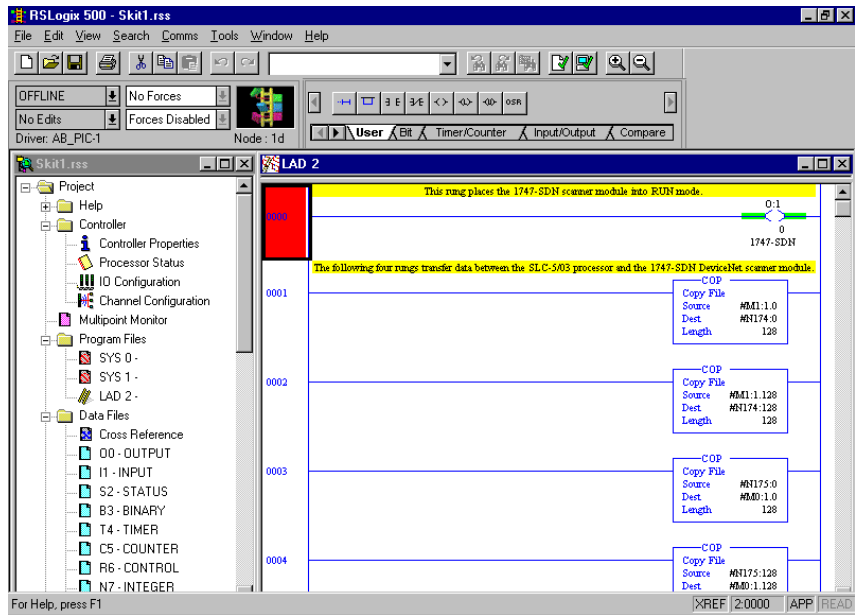

3. From the Comms menu, choose Go Online.

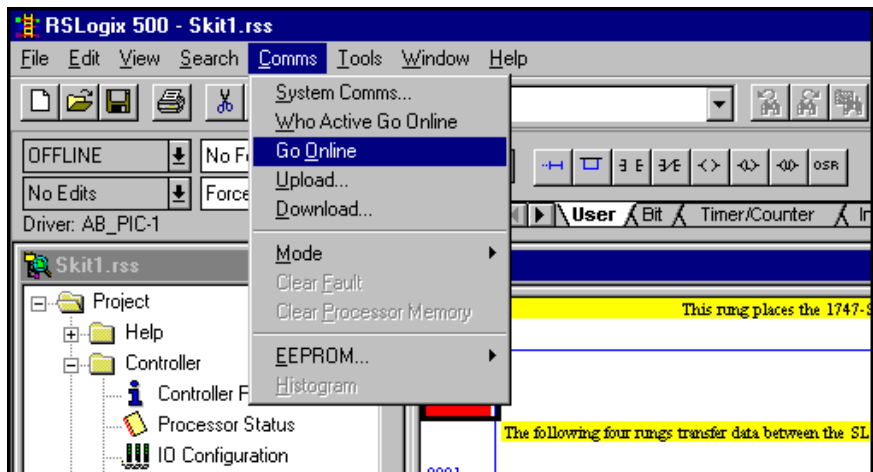

- In the navigation window on the left, scroll down to the Data Files.

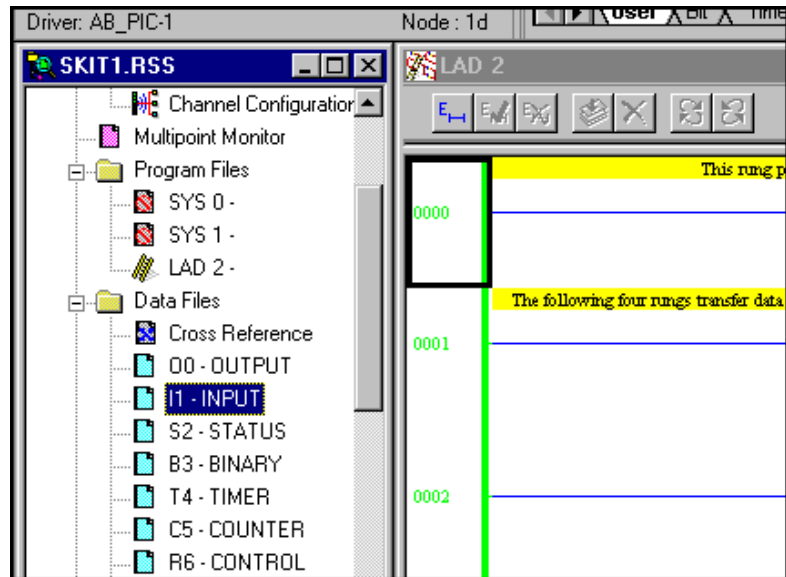

You can monitor the data coming from and going to devices on the DeviceNet network using your ladder logic software. Remember, you determine the location of the inputs and outputs by the scanlist and datatable map. In Chapter 4, you created the scanlist and datatable map in the RSNetWorx and downloaded the configuration to the scanner.

Refer to the Help screens in the RSNetWorx. Help gives you the data formats of these devices and information as to why certain bits in the data behave a certain way.

- From Data Files, double click  I1 - INPUT .

You see a similar screen:

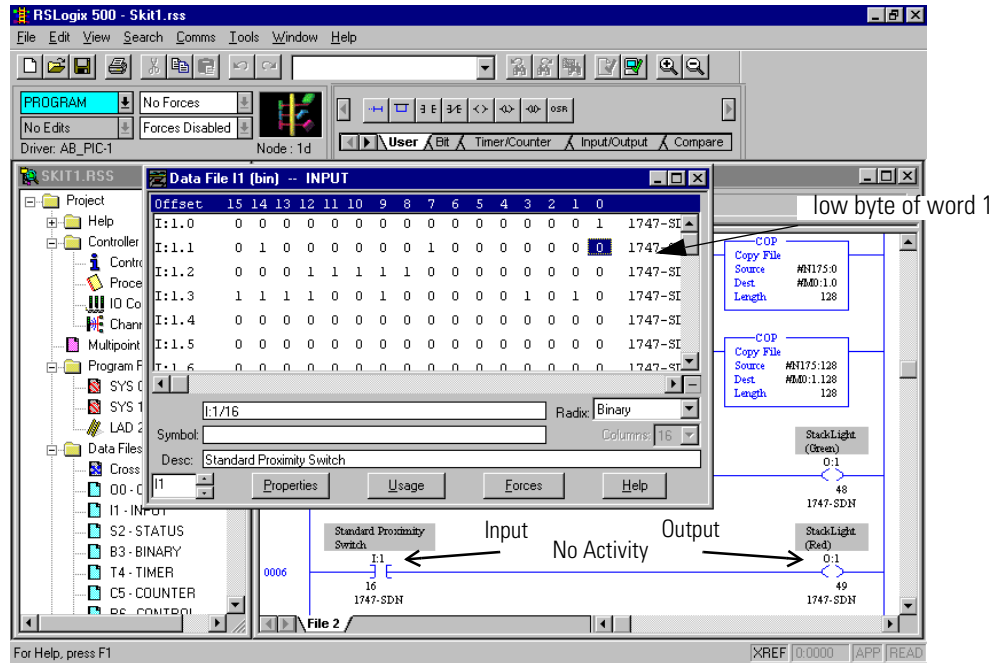

In this screen, we have placed the cursor on the Standard Proximity Switch. Watch the “0” in the low byte of word 1 change to a “1” when you place a metal object on the switch.

- Place a piece of metal in front of the Standard Proximity Switch and watch the bytes change. Notice the Input and Output activity in the ladder.

You see a similar screen:

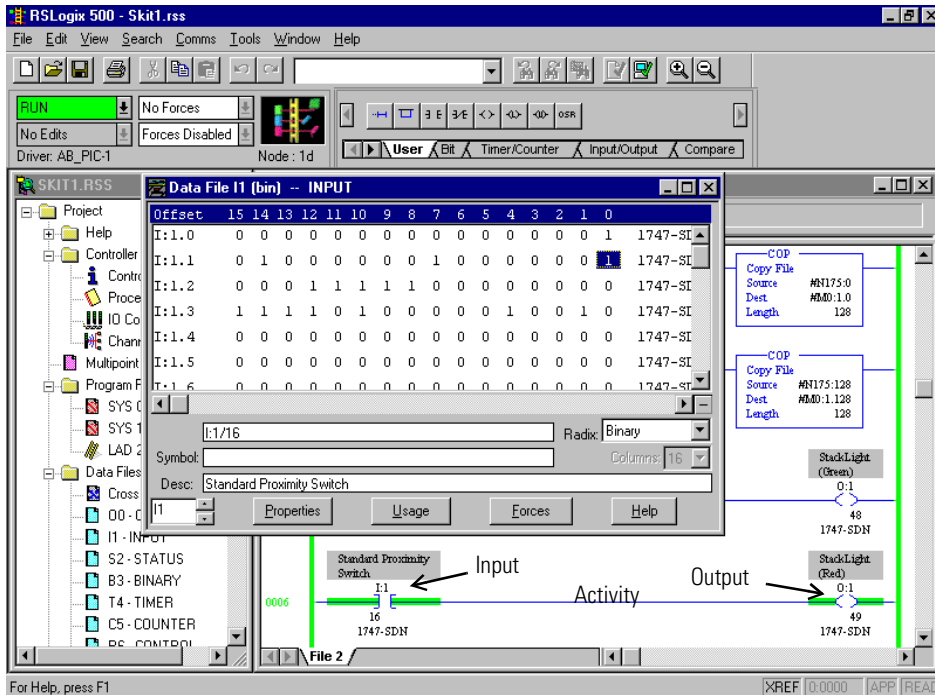

7. Minimize the Inputs window.

Now let's monitor the data outputs.

8. From Data Files, double click  00 - OUTPUT .

You see a similar screen:

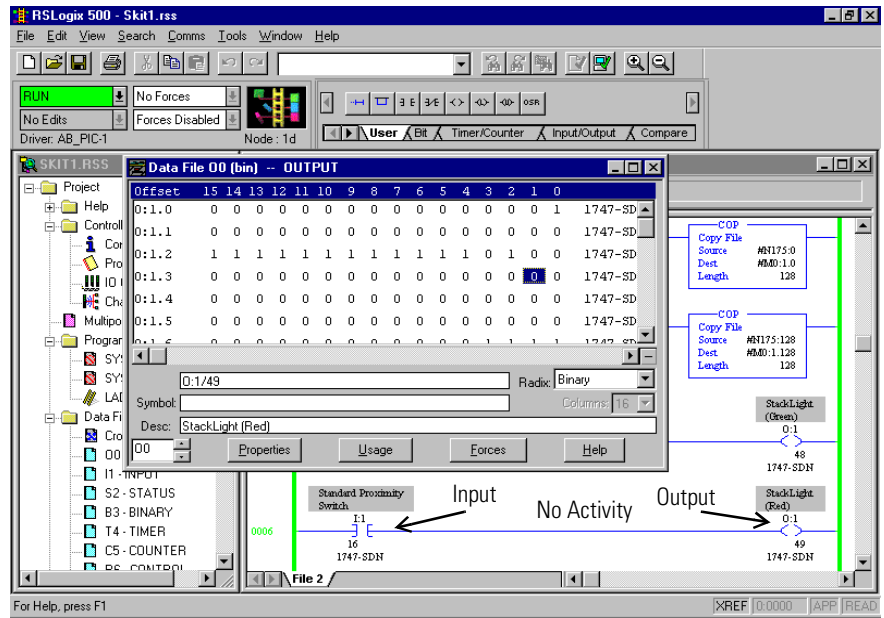

9. Again, place a metal object on the Standard Proximity Switch.

You see a similar screen:

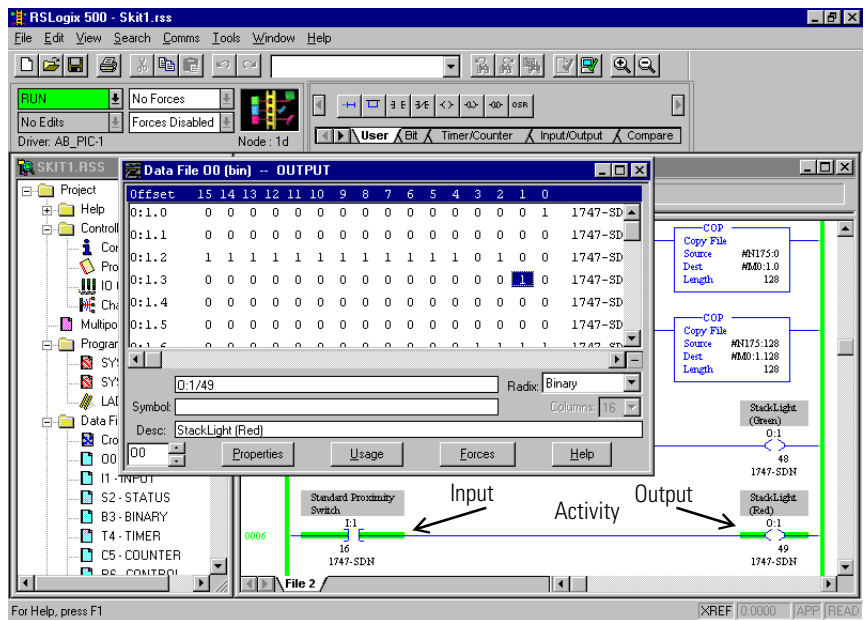

In this screen, we have placed the cursor on the Stack Light(Red).

10. Watch the 0 in the low byte of word 3 change to a 1 when you place the metal object against the switch.

Experiment with the other devices using steps 1 through 6 as an example.

11. Try the RightSight Photoelectric Sensor.
12. Place your hand in front of the RightSight Photoelectric Sensor.
13. Monitor the I/O Data.
14. Watch the ladder activity.
15. Watch the ControlTower Stack Light illuminate.
16. Try the Inductive Proximity Switch.
17. Place a metal object a varying distances from the switch.
18. Watch the LED's on the output section of the CompactBlock I/O fluctuate.
19. Monitor the I/O Data.
20. Watch the ladder activity.
21. In your ladder logic, watch the analog data values change in relation to the distance between the switch and the metal object.

Congratulations! You have now completed your Starter Kit.

Numeric Code Display Summary

Use the table below as a reference to find the definition of scanner messages. Refer to your scanner's documentation for information about scanner diagnostics.

Table A.A Scanner Message Definitions

Numeric Code	Description	Take this action:
Network Address Displays 0-63	Normal operation. The numeric display matches the scanner's node address on the DeviceNet network.	None.
70	Module failed Duplicate Node Address check.	Change the module channel address to another available one. The node address you selected is already in use on that channel.
71	Illegal data in scan list table (node number alternately flashes)	Reconfigure the scan list table and remove any illegal data.
72	Slave device stopped communicating (node number alternatively flashes)	Inspect the field devices and verify connections.
73	Device key parameters do not match scan list table entry (node number alternate flashes).	Enter a matching scan list device ID. Be certain that the device at the flashing node address matches the desired key parameters (vendor, product code, product type).
74	Data overrun on port detected.	Modify your configuration and check for invalid data.
75	No scan list is active in the module.	Enter a scan list.
76	No direct network traffic for the module detected.	None. The module hearts other network communication.
77	Data size returned does not match scan lists entry (node number alternately flashes).	Reconfigure your module and change the addressing.
78	Slave device in scan list table does not exist (node number alternatively flashes).	Add the device to the network, or delete the scan list entry for that device.
79	Module has failed to transmit a message.	Be certain that your module is connected to a valid network. Check for disconnected cables. Verify baud rate.
80	Module is in IDLE mode.	None.
81	Module is in FAULT mode.	None.
82	Error detected is sequence of fragmented I/O messages from device (node number alternately flashes).	Check scan list table entry for slave device to be certain that input and output data lengths are correct. Check slave device configuration.
83	Slave device is returning error responses when module attempts to communicate with it (node number alternately flashes).	Check scan list table entry. Check slave device configuration.
84	Module is initializing the DeviceNet channel.	None. This code clears itself once module attempts to initialize all slave devices on the channel.

Table A.A Scanner Message Definitions

Numeric Code	Description	Take this action:
85	Data size returned is bigger than expected.	Check accuracy of scan list table entry. Check slave device configuration.
86	Device is producing idle state data while the scanner is in Run Mode.	Check device configuration/slave node status.
87	Available for allocation. Scanner has not yet been detected by allocated master, or slave mode is enabled but scanner is not allocated to master.	Monitor scanner to determine if error code clears when master detects scanner. If error remains, check scanner slave mode configuration.
88	This is an error. At power-up and reset, the module displays all 14 segments of the node address and status display LEDs.	None.
90	User has disabled communication port.	Reconfigure your module. Check the disable bit in the Module command Register.
91	Bus-off condition detected on comm port module is detecting communication error.	Check Device connections and physical media integrity. Check system for failed slave devices or other possible sources of network interference.
92	No network power detected on comm port	Provide network power. Be certain that the module drop cable is providing network power to module comm port.
95	Application FLASH update in progress.	None. Do not disconnect the module while application FLASH is in progress. You will lose any existing data in the module's memory.
97	Module halted by user command.	None.
98	Unrecoverable firmware failure.	Service or replace your module.
99	Unrecoverable firmware failure.	Service or replace your module.
E9	Non-volatile configuration corrupt.	Cycle power to module. Download configuration to module.



Allen-Bradley Publication Problem Report

If you find a problem with our documentation, please complete and return this form.

Pub. Title/Type DeviceNet Starter Kit User Manual

Cat. No. 1787-GEN2SKIT, -2, -3, -4, -5, -6, -7 Pub. No. DNET-UM003A-EN-P Pub. Date August 2000 Part No. 957345-19

Check Problem(s) Type:	Describe Problem(s)	Internal Use Only
<input type="checkbox"/> Technical Accuracy	<input type="checkbox"/> text <input type="checkbox"/> illustration	
<input type="checkbox"/> Completeness What information is missing?	<input type="checkbox"/> procedure/step <input type="checkbox"/> illustration <input type="checkbox"/> definition	<input type="checkbox"/> info in manual (accessibility)
	<input type="checkbox"/> example <input type="checkbox"/> guideline <input type="checkbox"/> feature	<input type="checkbox"/> info not in manual
	<input type="checkbox"/> explanation <input type="checkbox"/> other	
<input type="checkbox"/> Clarity What is unclear?		
<input type="checkbox"/> Sequence What is not in the right order?		
<input type="checkbox"/> Other Comments Use back for more comments.		

Your Name _____ Location/Phone _____

Return to: Marketing Communications, Rockwell Automation., 1 Allen-Bradley Drive, Mayfield Hts., OH 44124-6118 Phone:(440) 646-3176
FAX:(440) 646-3525

Other Comments

PLEASE FOLD HERE

PLEASE REMOVE

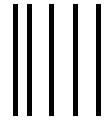

NO POSTAGE
NECESSARY
IF MAILED
IN THE
UNITED STATES

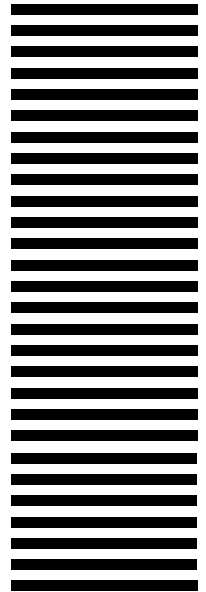

BUSINESS REPLY MAIL
FIRST-CLASS MAIL PERMIT NO. 18235 CLEVELAND OH

POSTAGE WILL BE PAID BY THE ADDRESSEE



**Rockwell
Automation**

1 ALLEN-BRADLEY DR
MAYFIELD HEIGHTS OH 44124-9705



Numerics

- 1747-SDN** 1-4
- 1756-DNB** 1-4, 1-5
- 1770-KFD** 1-4
 - connecting 2-17
- 1771-SDN** 1-4
 - setting node address 2-16
 - setup 2-15
- 1784-PCD** 1-5
 - install the card 2-19
- 1784-PCIDS** 1-5

A

- ArmorBlock MaXum I/O** 1-9, 3-15
 - commission 3-14
- assistance**
 - Rockwell Automation support services 1-10
- automap** 4-8

C

- cable base** 2-9
- cable installation**
 - KwikLink 2-5
- checklist** 1-2
- commission nodes** 3-1
- CompactBlock I/O** 1-9
 - connect 3-17
- CompactBlock I/O Module**
 - commission 3-19
- configure drivers** 3-6
- configure your scanner** 4-3
- connect devices** 2-22
- ControlTower Stack Light**
 - commission 3-25
 - connect 3-24

D

- data inputs** 5-9
- data outputs** 5-11
- demonstration**
 - ladder logic 5-1
 - steps to run 5-3
- demonstration configuration** 3-5
- DeviceNet**
 - network definition 1-1
 - what is its intent? 1-1
- download the scanlist** 4-5

E

- Electronic Data Sheets** 3, 9
- equipment you must provide** 1-5
- errors**
 - scanner display codes A-131

F

- F5** 3-25

H

- hardware**
 - you need for your Starter Kit 1-3
- Help**
 - related publications 1-11

I

- IDC blades** 2-5
- Inductive Proximity Switch** 1-9, 5-1
 - behavior 5-1
 - commission 3-27
 - connect 3-26
 - edit I/O Parameters 4-13

K

- KwikLink** 2-9
 - cable installation
 - IDC connector 2-5
- KwikLink Media System**
 - assemble 2-4
- KwikLink Tap (IDC)** 2-5
- KwikLink tap (IDC)** 1-7

L

- ladder logic filenames** 5-2
- ladder logic illustrated**
 - SKIT1 5-4
 - SKIT2 5-4
 - SKIT3 5-5
 - SKIT4 5-5
 - SKIT5 5-6
 - SKIT6 5-6
 - SKIT7 5-7

M

- mapping inputs** 4-17

mapping outputs 4-22

messages

scanner A-1

monitor the I/O Data 5-8

P

PCD driver software

installing 2-19

power supply 1-5

R

red X 3-39

RightSight Photoelectric Sensor 1-9, 5-1

behavior 5-1

connect 3-30

Rockwell 1-10

RSLinx 3-6, 3-21

RSNetWorx 1-9

online help 3-5

S

scanner

numeric code display A-1

SKIT1 1-4, 1-8

connect 1770-KFD 2-17

ladder logic 5-2

SKIT2 1-4, 1-8

install the 1784-PCD 2-19

ladder logic 5-2

SKIT3 1-4, 1-8

connect 1770-KFD 2-17

ladder logic 5-2

SKIT4 1-4, 1-8

install the 1784-PCD 2-19, 2-20

ladder logic 5-2

SKIT5 1-4, 1-8

ladder logic 5-2

SKIT6 1-5, 1-8

connect 1770-KFD 2-17

install the 1784-PCD 2-19, 2-20

ladder logic 5-2

SKIT7 1-5, 1-8

ladder logic 5-2

placing 2 devices on the network 3-5

software

you need for your Starter Kit 1-3

Standard Proximity Switch 1-9, 5-1

behavior 5-1

monitor I/O data 5-10

Starter Kit

construct 2-1

set up your 1-2

Starter Kit Components 1-6

Support

services 1-10

T

techniques used in manual 5

www.rockwellautomation.com

Power, Control and Information Solutions Headquarters

Americas: Rockwell Automation, 1201 South Second Street, Milwaukee, WI 53204-2496 USA, Tel: (1) 414.382.2000, Fax: (1) 414.382.4444

Europe/Middle East/Africa: Rockwell Automation, Vorstlaan/Boulevard du Souverain 36, 1170 Brussels, Belgium, Tel: (32) 2 663 0600, Fax: (32) 2 663 0640

Asia Pacific: Rockwell Automation, Level 14, Core F, Cyberport 3, 100 Cyberport Road, Hong Kong, Tel: (852) 2887 4788, Fax: (852) 2508 1846

Publication DNET-UM003A-EN-P - August 2000

Supersedes Publication DN-6.5.16 - November 1999

PN 957345-19

© 2000 Rockwell International Corporation. Printed in the U.S.A.