



 **Allen-Bradley**

IntelliVAC™ Contactor Control Module

Bulletin 1503VC

User Manual

Rockwell
Automation

Important User Information

Read this document and the documents listed in the Additional Resources section about installation, configuration, and operation of this equipment before you install, configure, operate, or maintain this product. Users are required to familiarize themselves with installation and wiring instructions in addition to requirements of all applicable codes, laws, and standards.

Activities including installation, adjustments, putting into service, use, assembly, disassembly, and maintenance are required to be carried out by suitably trained personnel in accordance with applicable code of practice.

If this equipment is used in a manner not specified by the manufacturer, the protection provided by the equipment may be impaired.

In no event will Rockwell Automation, Inc. be responsible or liable for indirect or consequential damages resulting from the use or application of this equipment.

The examples and diagrams in this manual are included solely for illustrative purposes. Because of the many variables and requirements associated with any particular installation, Rockwell Automation, Inc. cannot assume responsibility or liability for actual use based on the examples and diagrams.

No patent liability is assumed by Rockwell Automation, Inc. with respect to use of information, circuits, equipment, or software described in this manual.

Reproduction of the contents of this manual, in whole or in part, without written permission of Rockwell Automation, Inc., is prohibited.

Throughout this manual, when necessary, we use notes to make you aware of safety considerations.



WARNING: Identifies information about practices or circumstances that can cause an explosion in a hazardous environment, which may lead to personal injury or death, property damage, or economic loss.



ATTENTION: Identifies information about practices or circumstances that can lead to personal injury or death, property damage, or economic loss. Attentions help you identify a hazard, avoid a hazard, and recognize the consequence.

IMPORTANT

Identifies information that is critical for successful application and understanding of the product.

Labels may also be on or inside the equipment to provide specific precautions.



SHOCK HAZARD: Labels may be on or inside the equipment, for example, a drive or motor, to alert people that dangerous voltage may be present.



BURN HAZARD: Labels may be on or inside the equipment, for example, a drive or motor, to alert people that surfaces may reach dangerous temperatures.



ARC FLASH HAZARD: Labels may be on or inside the equipment, for example, a motor control center, to alert people to potential Arc Flash. Arc Flash will cause severe injury or death. Wear proper Personal Protective Equipment (PPE). Follow ALL Regulatory requirements for safe work practices and for Personal Protective Equipment (PPE).

Product Description

Chapter 1

Introduction	1-1
Description	1-1
IntelliVAC Features	1-2
IntelliVAC Versions	1-3
Specifications	1-4
Mounting and Connections	1-4
Configuration	1-4
Firmware	1-4
Electrical Ratings (Table 1.A)	1-5
Mechanical Ratings (Table 1.B)	1-6
Altitude Derating (Table 1.C)	1-6

Receiving and Storage

Chapter 2

Receiving	2-1
Storage	2-1

Installation and Wiring

Chapter 3

General Precautions	3-1
Safety and Codes	3-1
Arrangements	3-2
Integral to an Allen-Bradley MV Controller	3-2
OEM	3-3
Fuse Protection	3-6
Grounding	3-6
Connections	3-7
Control Power	3-7
Status Relays	3-7
Interface Connections	3-8
Wiring Guidelines Electrically Held Contactors	3-10
Two-Wire Control	3-11
Three-Wire Control	3-12
Wiring Guidelines Mechanically Latched Contactors	3-14
Mechanically Latched Contactors	3-15
Capacitor Trip	3-14
Motor Jogging Control	3-17
Time Delay Undervoltage	3-18

Setup and Commissioning	Chapter 4
	IntelliVAC Configuration 4-1
Monitoring & Troubleshooting	Chapter 5
	Introduction 5-1
	Module Status 5-1
	Contactactor Status 5-2
	Series B Design 5-2
Spare Parts	Chapter 6
	Spare Parts List 6-1
	Optional Equipment 6-1
Appendix A	Typical Contactactor Drop-out Times
	Table A.1 – Contactactor Drop-out Times A-1

Product Description

Introduction

This document contains information for the Allen-Bradley Bulletin 1503VC IntelliVAC™ control module. The Bulletin 1503VC is used to control the Allen-Bradley Bulletin 1502 vacuum contactors that are a significant component of the Bulletin 1500/1900 Centerline Medium Voltage Motor Controllers offered by Rockwell Automation.

An IntelliVAC control module may also be provided as a loose component, for application with a Bulletin 1502 contactor by a third party (OEM).

Description

IntelliVAC is an efficient and flexible solution for controlling medium voltage vacuum contactors used in motor starter and feeder applications. IntelliVAC may be used to control both 400 and 800 Amp contactors. Electrically held and mechanically latched contactor types can be controlled with IntelliVAC.



Figure 1.1 – IntelliVAC Contactor Control Module

Description (cont.)

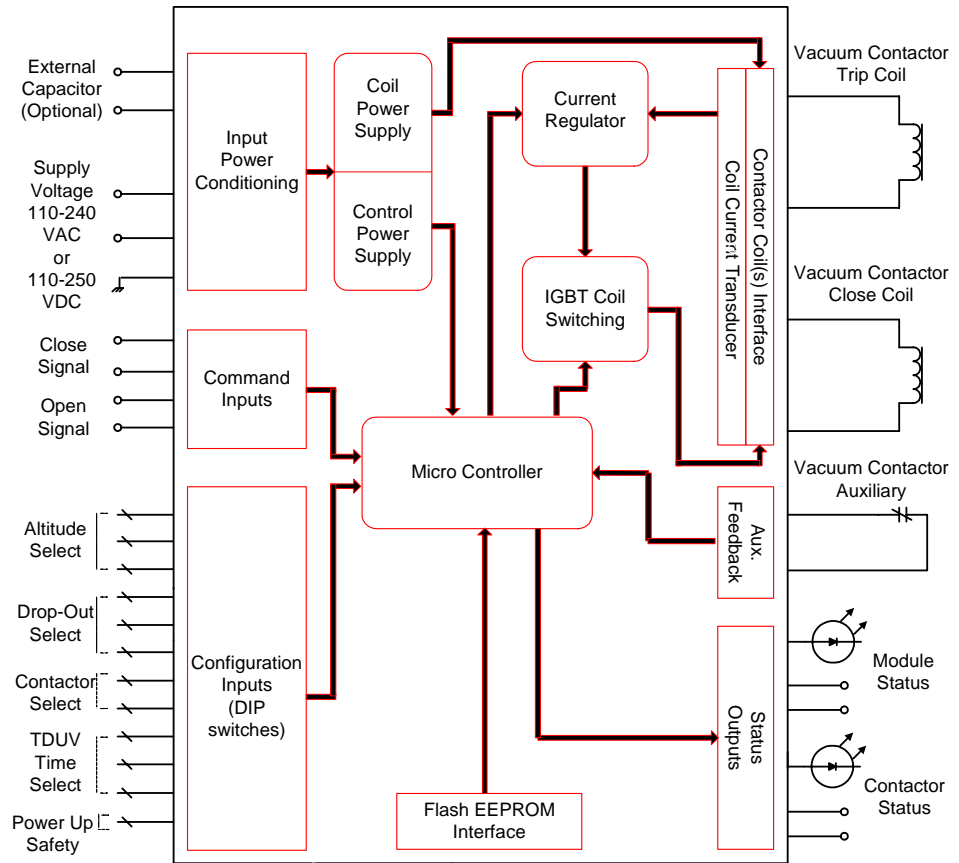

Figure 1.2 – IntelliVAC Block Diagram

IntelliVAC Features

- A wide range of supply voltage (110 – 240 V AC 50/60 Hz, 110 - 250 V DC) allows implementation in multiple applications
- Consistent vacuum contactor pick-up time (at a given supply voltage) ensures repeatable performance
- Selectable vacuum contactor drop-out time improves coordination with upstream power fuses
- Electronic altitude compensation (400 A only) eliminates mechanical compensation required for altitudes above 1,000 meters (800 A contactors include a user-friendly altitude adjustment)
- Power loss ride-through (TDUV) allows the vacuum contactor to remain closed during short power loss (may require an optional external capacitor, dependant on ride-through time)

IntelliVAC Features (cont.)

- Anti-kiss and anti-pumping protection ensure that the vacuum contactor close – open sequence occurs as expected, avoiding rapid re-closure due to faulty control devices
- Delayed restart protects the vacuum contactor by ensuring that the rated duty cycle is not exceeded
- Temporary jog function (electrically held contactors only) allows the motor to be positioned for process set-up

IntelliVAC Versions

Series A There are two versions of IntelliVAC control. The first type is used to control vacuum contactors that are electrically held, with a single electrical coil that is economized electronically. The second is used to control mechanically latched vacuum contactors.

Series B There is a single version of IntelliVAC, to control both electrically held and mechanically latched vacuum contactors.

Refer to Chapter 6, for catalog numbers for each version of IntelliVAC.

A Series B IntelliVAC module can be used to replace a Series A module.

Specifications

Mounting & Connections

The IntelliVAC control modules are mounted using two (2) screws (see Figure 1.3). They are typically located in the low voltage control panel of the medium voltage controller (Bulletin 1500/1900 controllers, in the case of Rockwell Automation).

IntelliVAC is interfaced to the Bulletin 1502 vacuum contactors using a “quick” connector, located at the module, a wire harness and “quick” connector at the contactor. Control power and other control circuit connections are similarly achieved with “quick” connectors.

Configuration

IntelliVAC is easily configured for a wide variety of medium voltage motor and feeder control applications. It is configured using DIP switches, located within the enclosure (front side). Please refer to Chapter 4 for information.

Bulletin 1500/1900 controllers are shipped with IntelliVAC pre-configured for the required application. Please refer to the documents provided with the order.

Firmware

IntelliVAC has firmware stored in flash EEPROM; therefore, this may be updated in the field (if necessary). The IntelliVAC board firmware is updated using the mini-DIN connector, which is accessible inside the enclosure.

Table 1.A – Electrical Ratings

Main Input Voltage (L1 to L2/N)	AC – 110 to 240 V rms, +10/-15%, 47 to 63 Hz DC – 110 to 250 V, +10/-15%				
Main Input Current (L1 to L2/N) ③	Description	Contactor Ratings (Amps)	Control Voltage (AC or DC)	AC Rating	DC Rating
	Inrush Current	400/800	120/240	25 A peak (1/2 cycle)	25 A peak
	Idle Current (Maximum without contactor coil energized)	400/800	120/240	125 mA	35 mA
	Hold Current ④ (maximum)	400/800	120/240	300 mA	100 mA
	Close Current ④ (0.2 sec)	400	120	4.6 A	3.6 A
			240	3.4 A	3.3 A
		800	120	11.3 A	4.8 A
			240	8.9 A	4.5 A
	Trip Current (latch) ④ (0.2 sec)	400	120	7.0 A	3.7 A
			240	3.6 A	2.0 A
800		120	7.0 A	3.3 A	
		240	4.3 A	1.9 A	
Command Inputs ① ⑤	AC – 100 to 240 V rms DC – 24 to 250 V Maximum on state current for open or close command: 9mA _{AC} @ 250 V AC, 60Hz, T _A =60°C 9mA _{DC} @ 250 V DC, T _A =60°C Minimum on state current for open or close command: 2mA _{AC} @ 100 V AC, 60Hz, T _A =60°C 600µA _{DC} @ 24 V DC, T _A =60°C Maximum off state current for open or close command: 400µA _{AC} @ 11 V AC, 60Hz, T _A =60°C 400µA _{DC} @ 15 V DC, T _A =60°C				
Status Output Contacts	AC – 250 V rms, 5 A, R load; 2 A (reactive), PF=0.4 DC – 30 V, 5 A, R load; 2 A (reactive), L/R=7 ms				
Standards and Approvals	CE ②, cULus, CSA, IEC pending				

- ① T_A= Ambient Temperature
- ② Refer to Chapter 6 for suitable EMC filter needed to meet CE requirements.
Also refer to Chapter 3 for EMC filter installation guidelines.
- ③ Please consult Factory for DC input current ratings.
- ④ Includes idle current.
- ⑤ Ensure compatibility of IntelliVAC input ratings with those of circuit components activating these inputs.
Consider means of isolating/loading these signals, as required (using interposing relays or load resistors.)
Consult factory for assistance, if needed.

Specifications (cont.)

Table 1.B – Mechanical Ratings

Temperature	Operating: 0° to 60°C ambient at the control module ❶
	Non-Operating: -40° to 85°C
Altitude	-1000 to 5000 meters
Pollution	Pollution level II (as defined by UL 840 and IEC 60664-1)
Humidity	Class II
Shock and Vibration (Operational)	Shock – 15 g peak, 11 milliseconds
	Vibration – 10 to 57 Hz, 0.015 inch displacement peak to peak - 57 to 150 Hz, 2.5 g acceleration

❶ Ambient temperature is derated at altitudes above 1,000 meters (3,300 feet). Please refer to Table 1.C.

Table 1.C – Altitude Derating

Altitude	DIP Switch Setting 1, 2, 3 ❶	Maximum Operating Ambient at the control module (°C) ❷
-1000 to 0	000	60
1 to 1000	001	60
1001 to 2000	010	58
2001 to 3000	011	56
3001 to 4000	100	54
4001 to 5000	101	52

❶ Refer to Chapter 4.

❷ Derate by 2°C / 1000 m for high altitude operation

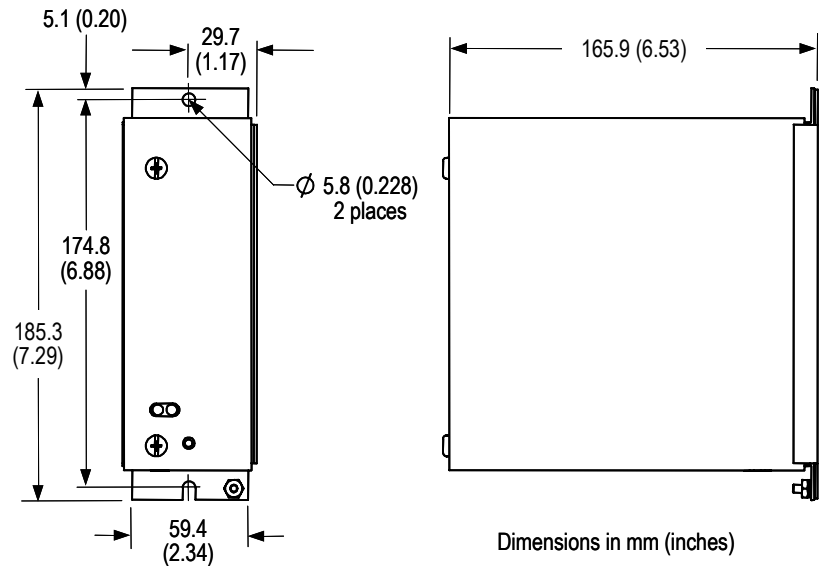

Figure 1.3 – Mechanical Dimensions

Receiving and Storage

Receiving

Upon receiving the controller, remove the packing and check for damage that may have occurred during shipping. Report any damage immediately to the claims office of the carrier.

NOTE: If the IntelliVAC module is an integral component of a complete MV controller (Bulletin 1500/1900), special receiving and handling instructions will apply. For details, refer to the service manual provided with the equipment.

Storage

It is important to consider the following storage requirements if you are not installing your controller immediately after receiving it.

- Store the controller in a clean, dry, dust-free environment.
- Storage temperature should be maintained between -40°C and 85°C (-40°F and 185°F).
- Relative humidity must not exceed 95%, non-condensing.

(This page is intentionally left blank.)

Installation and Wiring

General Precautions

In addition to the precautions listed throughout this manual, the following statements, which are general to the system, must be read and understood.

ATTENTION

The controller contains ESD (electrostatic discharge) sensitive parts and assemblies. Static control precautions are required when installing testing, servicing, or repairing the assembly. Component damage may result if ESD control procedures are not followed. If you are not familiar with static control procedures, refer to applicable ESD protection handbooks.

ATTENTION

An incorrectly applied or installed controller can damage components or reduce product life. Wiring or application errors, such as incorrect or inadequate AC supply, or excessive ambient temperatures, may result in malfunction of the system.

ATTENTION

Only personnel familiar with the controller and associated machinery should plan or implement the installation, start-up, and subsequent maintenance of the system. Failure to do this may result in personal injury and/or equipment damage.

Safety and Codes

ATTENTION

The Canadian Electrical Code (CEC), National Electrical Code (NEC), or other local codes outline provisions for safely installing electrical equipment. Installation **MUST** comply with specifications regarding wire type, conductor sizes, branch circuit protection, interlocking and disconnect devices. Failure to do so may result in personal injury and/or equipment damage.

Arrangements

The IntelliVAC is offered in two arrangements, Integral (part of a Bulletin 1500/1900 MV controller) or as an OEM component.

Integral to an Allen-Bradley MV Controller

The IntelliVAC is available as a primary component of an Allen-Bradley Bulletin 1500/1900 MV controller as shown in Figure 3.1.



Figure 3.1 - Typical IntelliVAC Installation within a Bulletin 1500/1900 MV Controller (Shown with optional external capacitor)

OEM

The IntelliVAC may be ordered as an OEM component. This allows the OEM to mount the components in a configuration most suitable to the motor controller equipment layout. Care must be exercised to ensure the IntelliVAC has adequate ventilation provided around it. Refer to Figure 3.2 for mounting the IntelliVAC. It is recommended that a minimum of 1.5 inches (38.1mm) of free air space be provided between the IntelliVAC and any solid barrier above or below.

The OEM is responsible for controller fusing, motor overload protection, control devices (eg. Start/Stop push buttons), and wiring between the IntelliVAC and 1502 vacuum contactor (using optional wire harness). Wiring and mounting for optional items, such as TDUV Capacitor are also the OEM's responsibility. Refer to Figure 3.3 or 3.4 for basic connections.

An optional EMI filter is required to meet CE EMC requirements (refer to Chapter 6 for recommended type).

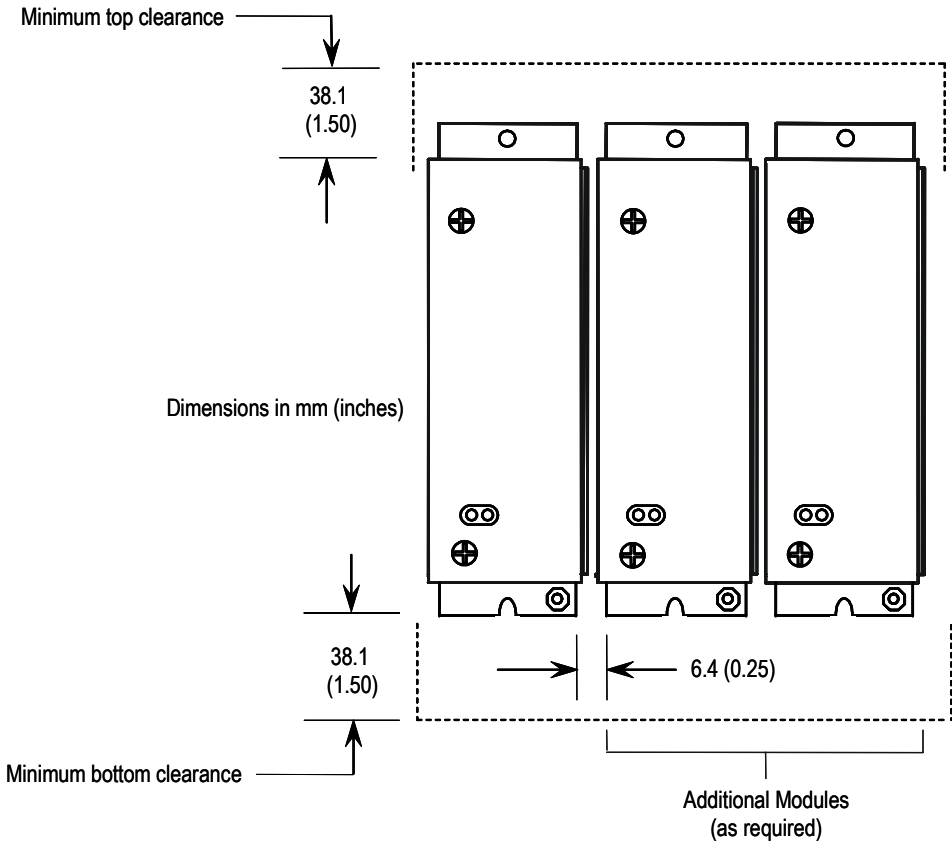
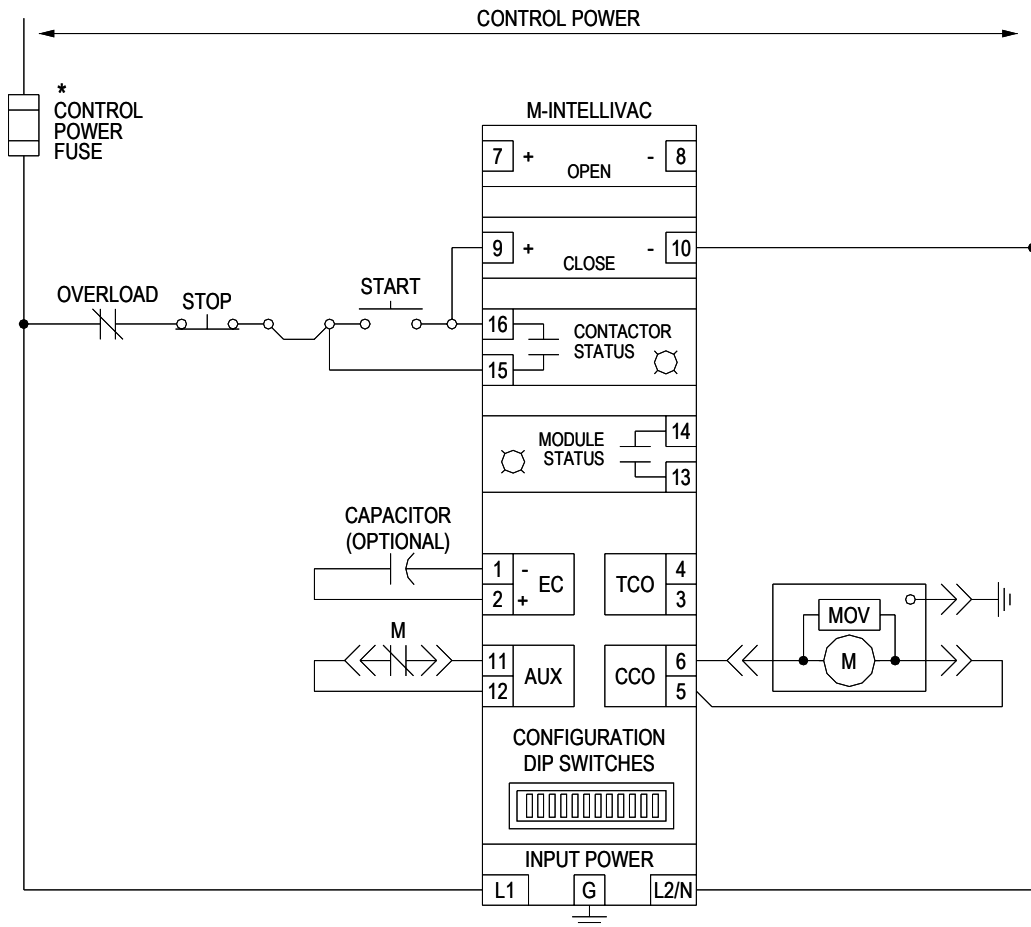

Figure 3.2 – Typical Mounting Configurations

Note: Adjacent IntelliVAC modules may be mounted with a minimum separation of 6.4 mm (0.25 inches).

Arrangements (cont.)



* Refer to Table 3.A for recommended fuse sizing.

Figure 3.3 – IntelliVAC Typical Schematic (Electrically Held Vacuum Contactor) Without Optional EMC Filter

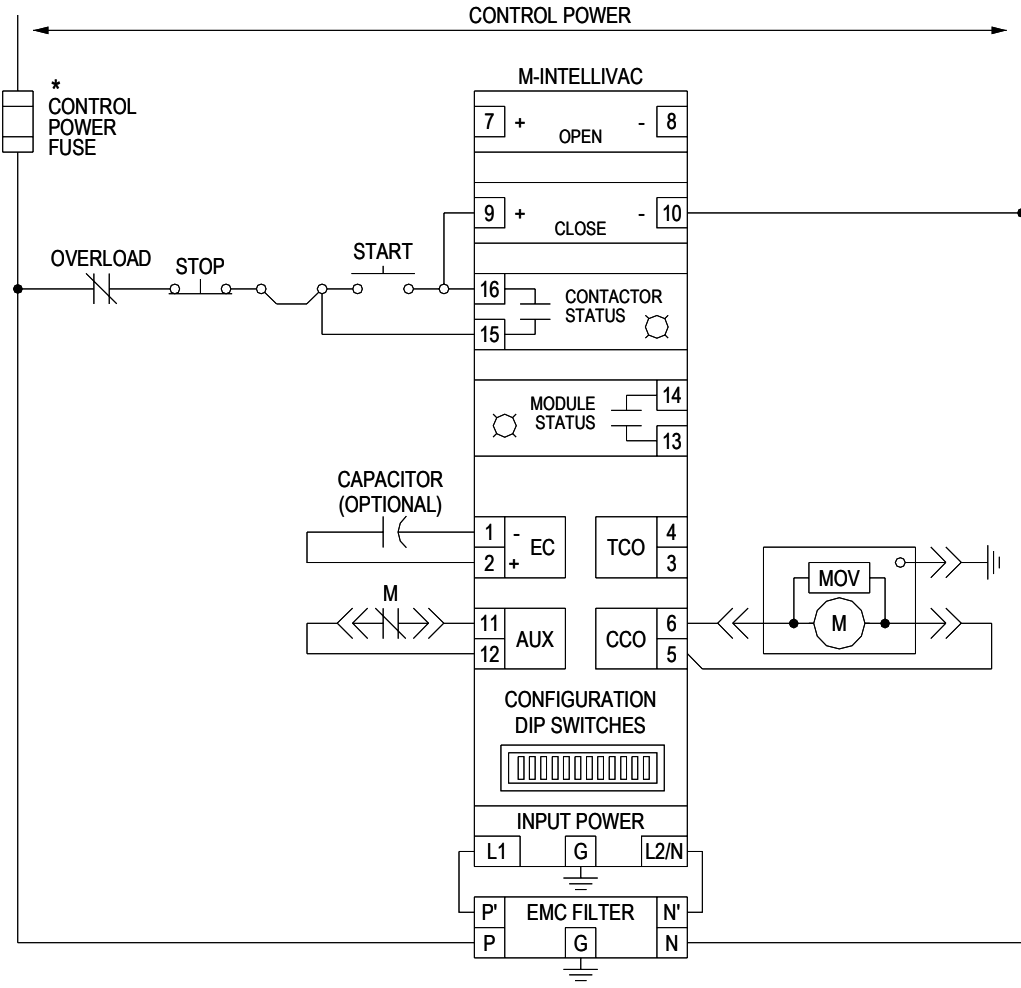

* Refer to Table 3.A for recommended fuse sizing.

Figure 3.4 – IntelliVAC Typical Schematic (Electrically Held Vacuum Contactor) With Optional EMC Filter

Fuse Protection

The IntelliVAC module requires external fuse protection to coordinate with the power supply and contactor. The fuse ratings shown in Table 3.A allow the passage of inrush currents expected when the contactor is closed, or from recommended external capacitors for the TDUV option. They will also protect the contactor coils in the event of a module malfunction.

The recommended fuses have been tested to ensure reliable protection of the module. If the supply voltage is DC, the module must be used with an external fuse that is approved for and rated to interrupt the DC voltage supply. The types listed are Ferraz-Shawmut Midget Fuses (1-1/2" X 13/32"). The TRM is a time-delay type, rated 250 VAC. The ATM is a fast-acting type, rated 500 VDC.

Table 3.A – IntelliVAC Fuse Protection

Rated Supply Voltage	Contactor Type	Recommended Fuse	
		(minimum)	(maximum)
110/120 VAC	400A EH	TRM 2	TRM 3.2
	800A EH	TRM 2	TRM 6.25
	400/800A ML	TRM 2	TRM 3.2
220/240 VAC	400A EH	TRM 2	TRM 6.25
	800A EH	TRM 2	TRM 6.25
	400/800A ML	TRM 2	TRM 6.25
125 VDC	400A EH/ML	ATM 3	ATM 3
	800A EH/ML	ATM 5	ATM 6
250 VDC	400A EH/ML	ATM 3	ATM 5
	800A EH/ML	ATM 5	ATM 6

EH = Electrically Held vacuum contactor

ML = Mechanically Latched vacuum contactor

Grounding

The IntelliVAC module must be connected to a common ground terminal (PE) on the controller panel. The ground terminal is located on top of the module enclosure for Series A design (refer to Figure 3.7), and on the bottom of module enclosure for Series B design, (refer to Figure 3.6)

ATTENTION



It is important that IntelliVAC is properly grounded using the ground connection provided. Failure to do so may result in damage to equipment or personal injury.

Connections

There are three green connectors on the IntelliVAC module for connections to the control circuitry. Connector plugs are provided with the module. If additional plugs are required, refer to Chapter 6, *Spare parts*.

Control Power

The IntelliVAC can accept either AC or DC control power. Refer to Table 1.A for acceptable input power and control signal ratings.

Control power is applied to the module with a two-pole connector located at the bottom rear portion of the module. Refer to Figures 3.5 and 3.6 for connections. The 'L1' connection is intended to be the 'Hot' or '+' side of the control power, and the 'L2/N' connection is intended to be the 'Neutral', 'Return', or '-' side of the control power.

In order to meet CE electromagnetic interference requirements, an external EMC filter must be installed. Refer to Chapter 6 for suitable EMC filter part number and install per Figure 3.4.

Status Relays

Status relay connections are accessed with a four-pole connector located at the bottom front portion of the module. Refer to Figure 3.5 or 3.6 for connections. There are two status relays, each with one normally-open contact:

Module Status: Terminals 13 and 14
 Contactor Status: Terminals 15 and 16

Refer to Chapter 5 *Monitoring and Troubleshooting* for a description of operation for the relays.

Refer to Table 1.A for electrical ratings of the status relays.

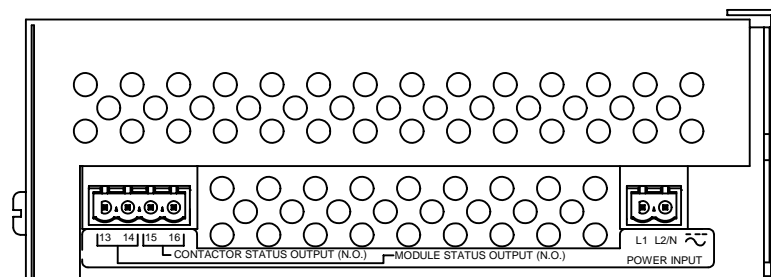

Figure 3.5 – Bottom side connections (Series A)

Connections (cont.)

Interface Connections

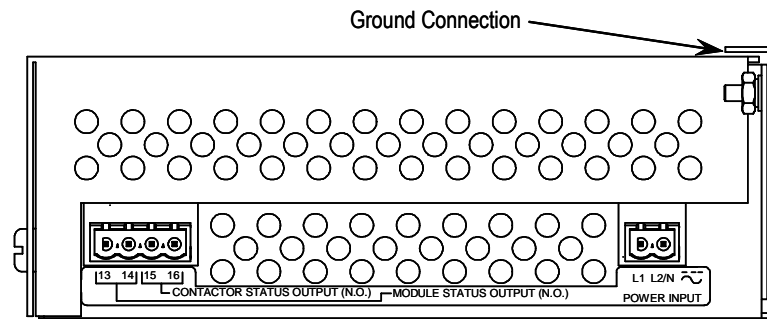

Figure 3.6 – Bottom side connections (Series B)

Interface Connections

All other control interface connections are made at a twelve-pole connector located on the top of the module. Refer to Figure 3.7 or 3.8 and Table 3.B for connections. Refer to the *Wiring Guidelines* section in this chapter for guidance in making connections to the control circuit.

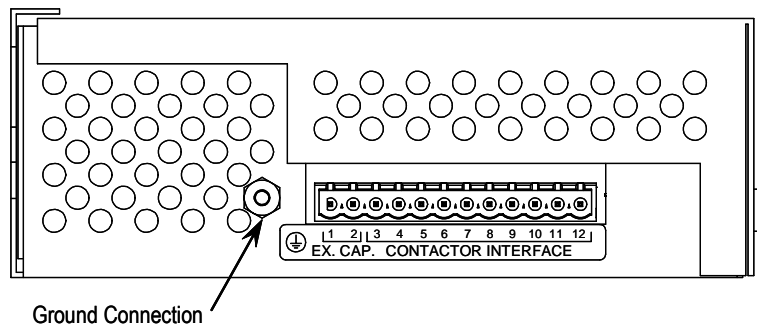

Figure 3.7 – Top side connections (Series A)

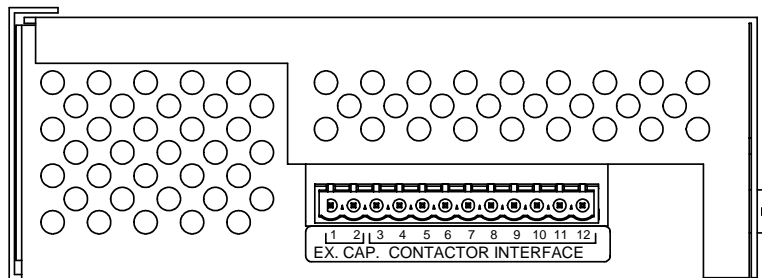

Figure 3.8 – Top side connections (Series B)

Table 3.B – Terminal Assignments for IntelliVAC Interface Connections ^❶

Terminal No.	Terminal Designation	Description
1	External capacitor (negative) ^❷	Power connection for TDUV or capacitor trip options only
2	External capacitor (positive) ^❷	
3	Latch trip coil (common) ^❷	Output for mechanical latch contactor trip coil
4	Latch trip coil ^❷	
5	Close coil (common)	Output to close coil of electrically held & mechanical latch contactors
6	Close coil	
7	Open / Jog command ^❷ ^❸	Input to open a mechanical latch contactor or jog an electrically held contactor (mutually exclusive)
8	Open / Jog command (common) ^❷ ^❸	
9	Close command ^❸	Input to initiate the closure of electrically held & mechanical latch contactors
10	Close command (common) ^❸	
11	Contactors auxiliary contact ^❸	Input to indicate the state of the contactor (typically wired to a normally closed auxiliary contact)
12	Contactors auxiliary contact ^❸	

^❶ Refer to Table 1.A for electrical ratings.

^❷ No connection required if option is not used.

^❸ Ensure compatibility of IntelliVAC input ratings with those of circuit components activating these inputs. Consider means of isolating/loading these signals, as required (using interposing relays or load resistors). Consult factory for assistance, if needed.

Wiring Guidelines Electrically Held Contactors

The IntelliVAC can be applied with two- or three-wire control circuits. The control system utilized will determine the configuration of the input wiring. Consider the following input and output for the type of control used:

- Terminals 9 and 10 Close Contactor
- Terminals 15 and 16 Contactor Status

In either case, the CLOSE input must receive a maintained voltage high to keep the contactor closed.

Note:

1. When used with electrically held contactors, the IntelliVAC allows close commands every six seconds. This is to ensure the rated contactor duty cycle is not exceeded.
2. If a contactor close command is applied and then removed in less than 500 milliseconds the IntelliVAC may fault. To clear the fault, module power has to be removed and reapplied.
3. If IntelliVAC powers up configured for an electrically held contactor, and the vacuum contactor is detected as being closed, the module will not respond to a close command until the vacuum contactor auxiliary contact input is in the correct (open) state and module power is removed and re-applied. (See Chapter 5). This is true if the power-up safety DIP switch is enabled.
4. In general, a Close command should only be applied 4 seconds after energizing IntelliVAC.

Two-Wire Control

If using two-wire control, the CLOSE contactor input is maintained high using a single contact. Momentarily opening this input will cause the IntelliVAC to open the contactor. Maintaining the contact will provide a CLOSE command to IntelliVAC (given that all permissives are satisfied). If a fault occurs, in addition to cycling control power to the IntelliVAC module, the CLOSE command must be removed for a minimum of 4 seconds, before being re-applied. Refer to Figure 3.9.

Some two-wire control schemes may be configured such that a close command is present when IntelliVAC is energized. In this case, the Power-Up Safety feature may be disabled by setting DIP switch 12 accordingly. (Available with an IntelliVAC using firmware 2.001 (or newer) refer to Table 4.B).

Note: Only disable the Power-Up safety feature when absolutely necessary. Doing so can create unsafe operating conditions.

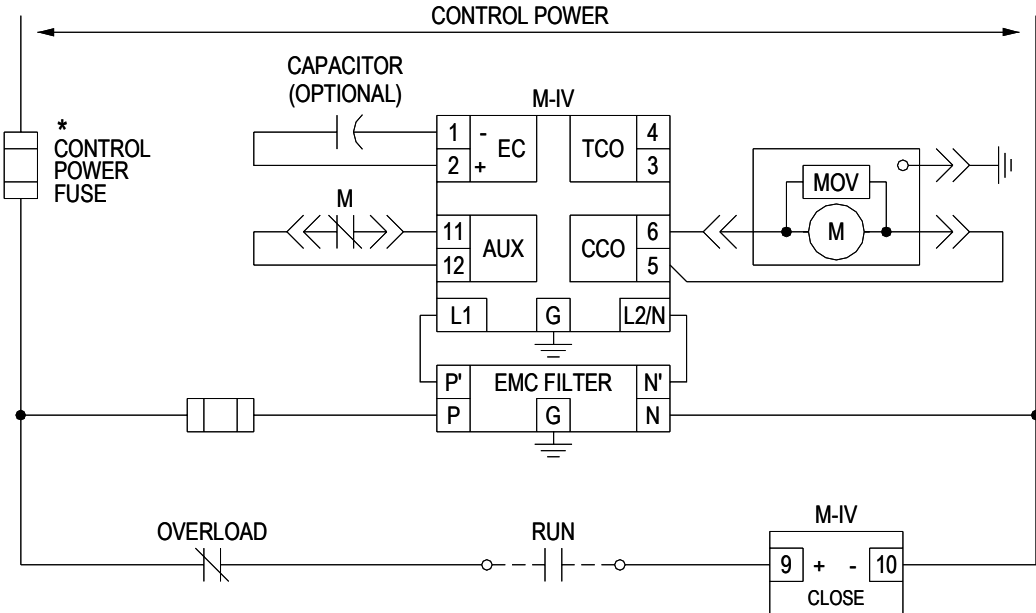

* Refer to Table 3.A for recommended fuse sizing.

Figure 3.9 – Two-Wire Control

Wiring Guidelines Electrically Held Contactors (cont.)

Three-Wire Control

If using three-wire control, the CLOSE contactor input is maintained high using two contacts. Momentarily opening this input will cause the IntelliVAC to open the contactor. Momentarily closing the START contact will provide a CLOSE command to IntelliVAC (given that all permissives are satisfied).

In this configuration, the STATUS output acts as a seal-in contact. If a fault occurs, in addition to cycling control power over to the IntelliVAC module, the CLOSE command must be removed for a minimum of 4 seconds before being re-applied. Refer to Figure 3.10.

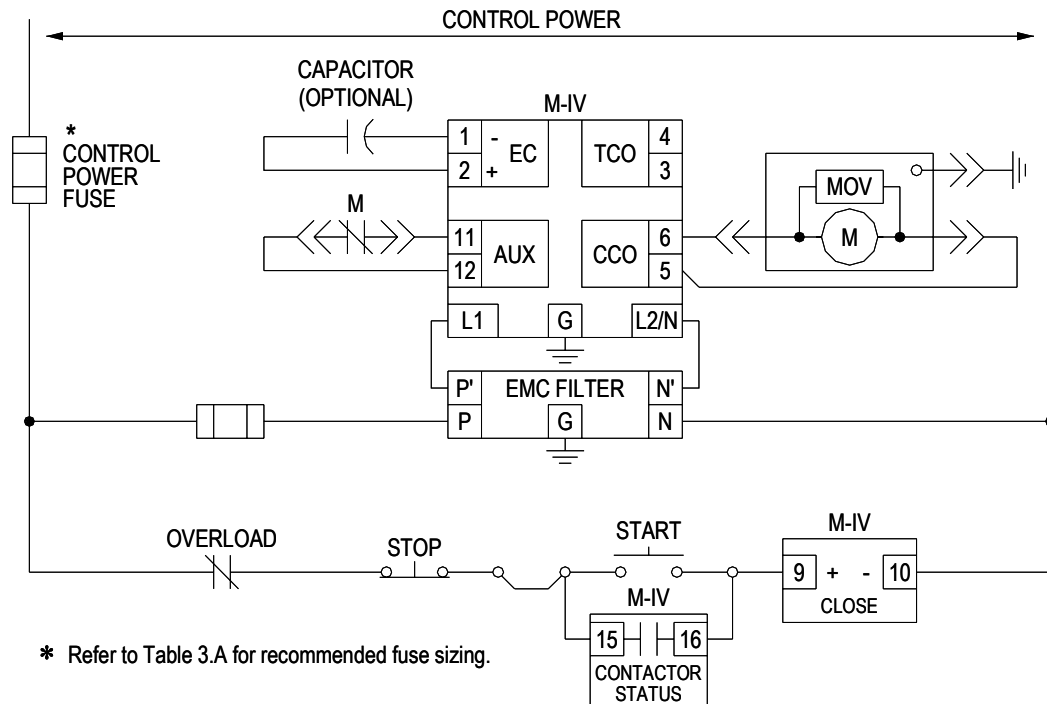
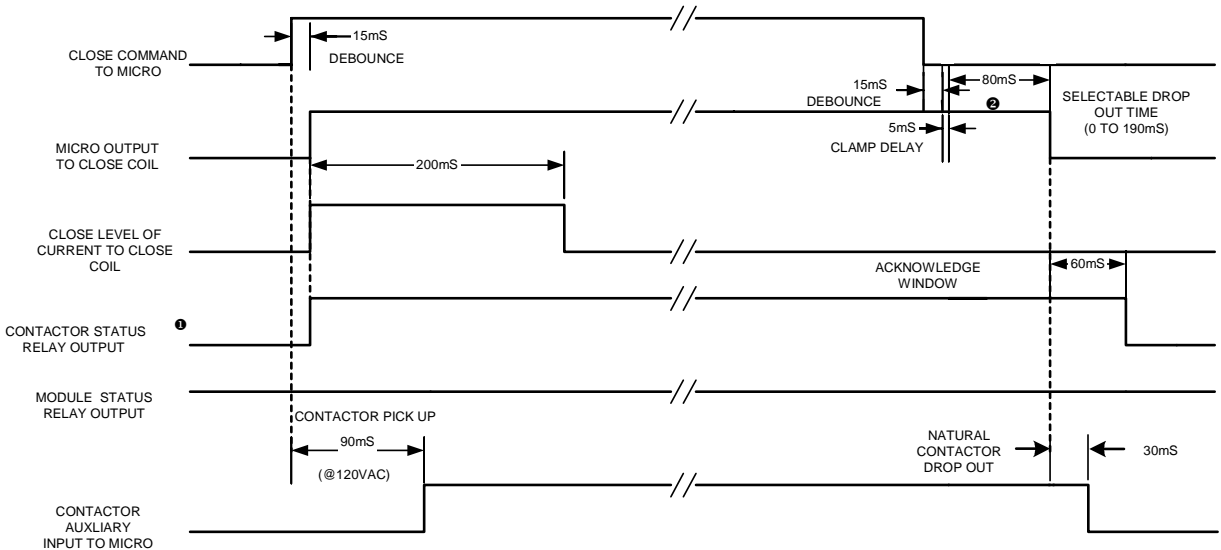

Figure 3.10 – Three-Wire Control



- ❶ Contact status relay closes on request to close. It will open if the contactor auxiliary contact does not close within 200 milliseconds and module will fault (opening module status relay).
- ❷ For this example, the 130 millisecond drop-out time has been selected. The base drop-out time is 50 milliseconds. The microcontroller delay is $130-50=80$ milliseconds.

Figure 3.11 – Timing Diagram 400A (Electrically Held) Contactor with IntelliVAC Control for three-wire Control

Wiring Guidelines Mechanically Latched Contactors

IntelliVAC control may be used for mechanically latched contactors. A momentary control signal is needed to close the contactor, and a second momentary control signal is needed to open the contactor. The momentary open/close commands must be at least 50 milliseconds in duration.

Refer to Figure 3.12 for a typical mechanical latch control scheme.

Note:

1. A mechanically latched contactor may already be closed when power is applied to the IntelliVAC control module.
2. It is permissible to apply an open command to the IntelliVAC module as power is re-applied.

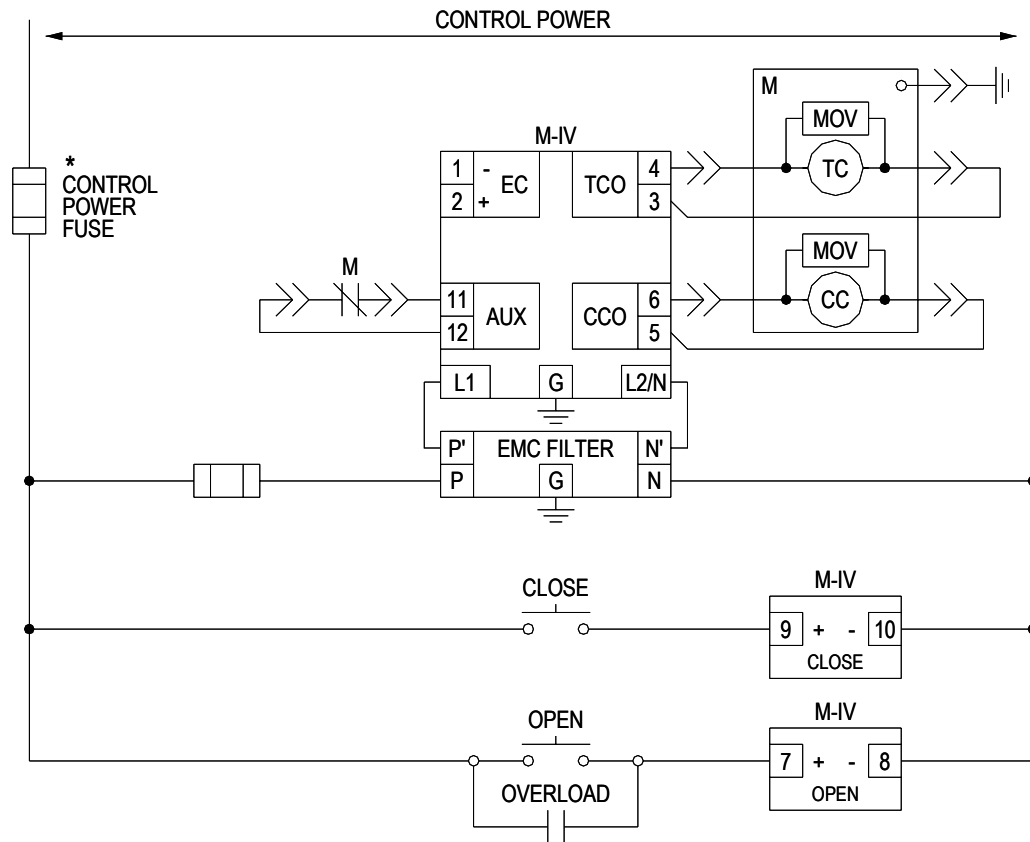

* Refer to Table 3.A for recommended fuse sizing.

Figure 3.12 – Mechanically Latched Contactor Control

Mechanically Latched Contactors

Capacitor Trip

The IntelliVAC can be configured to provide capacitor trip functionality with mechanically latched contactors. A capacitor must be connected to the IntelliVAC (terminals #1 and #2) in order to provide this capability. The capacitor provides control power for the IntelliVAC as well as stored energy to trip the contactor. Maximum recommended capacitor size is 1650 μF for 120V control or 330 μF for 240V control. Use of larger capacitors will require a current limiting circuit to prevent opening the control fuse on energization.

The IntelliVAC must receive an 'OPEN' command within a few seconds of losing AC control power. This time limit depends on voltage and capacitor size as shown in the table below. If the elapsed time exceeds this limit, the contactor cannot be tripped by IntelliVAC.

A separate voltage source is needed to provide the 'OPEN' command. This may be taken from the external capacitor as shown in Figure 3.13.

Table 3.C – Mechanically Latched Contactor – Capacitor Trip Times

Contactor Rating	Nominal Voltage (Vac)	Actual V_{input} (Vac)	Ext. Capacitor (μF)	Max. time for trip (sec)
400 Amp	120	120	1650	3.5
		110		2.7
		100		1.7
	240	240	330	7.5
		200		4.7

- Note:** Minimum capacitor voltage ratings
- 120V applications – 200V DC (250V DC preferred)
 - 240V applications – 400V DC (450V DC preferred)

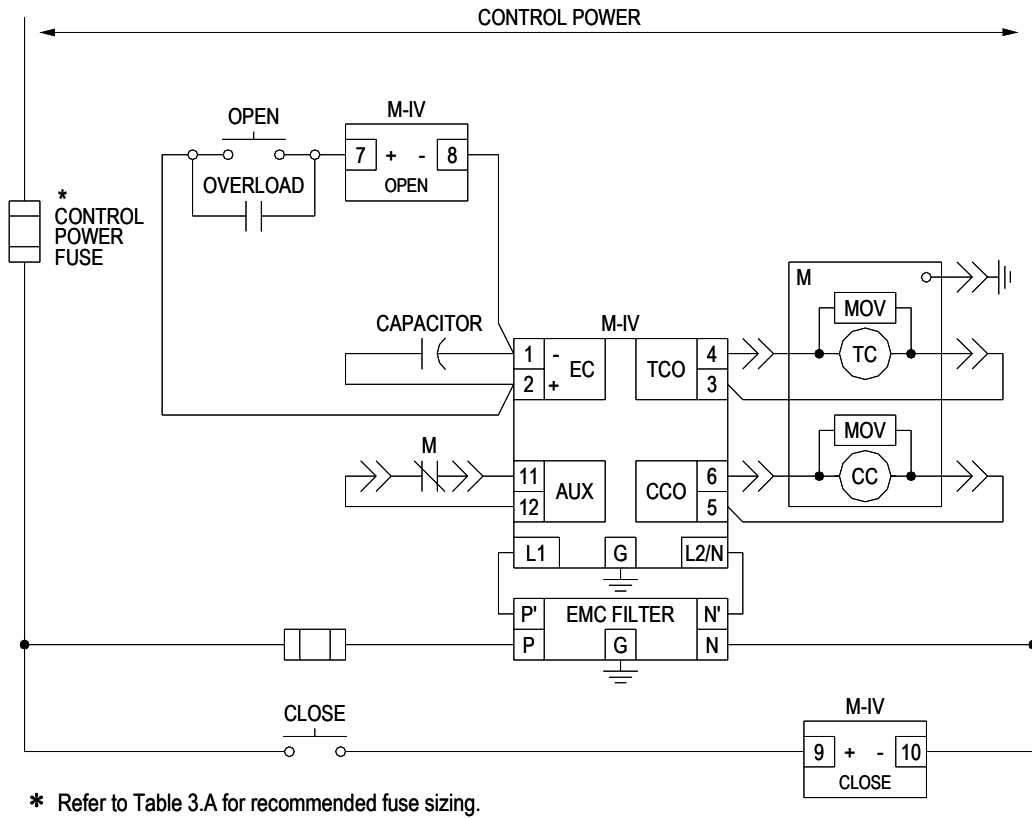
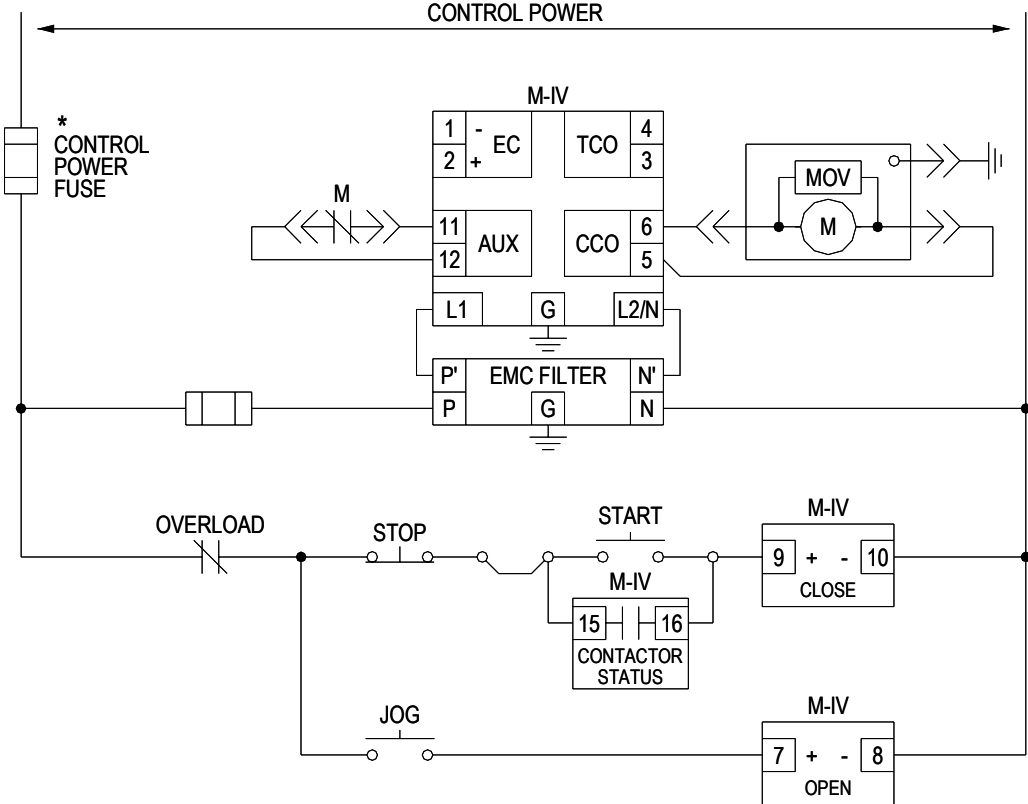

Figure 3.13 – Mechanically Latched Contactor with Capacitor Trip Option

Motor Jogging Control

When used with electrically held contactors, the IntelliVAC allows close commands every six seconds. This is to ensure the rated contactor duty cycle of 600 operations per hour is not exceeded.

For motor jogging operations, the second control input, or OPEN command, will close the contactor for as long as the input is present, and open the contactor when the input is removed. (Refer to Figure 3.14.) This method will bypass the standard six second motor re-start delay for jogging purposes only.



* Refer to Table 3.A for recommended fuse sizing.

Figure 3.14 – Motor Jogging Control

Time Delay Undervoltage

The IntelliVAC can be configured to provide time delay undervoltage (TDUV) protection. The feature is available to keep electrically held contactors closed during a voltage dip or brief power loss. This option may require the addition of a capacitor (see below). Refer to Chapter 6 for typical capacitor sizing. The capacitor is connected to terminals 1(-) and 2(+) of the IntelliVAC. (Refer to Figure 3.15.)

Table 4.B of the “Setup and Commissioning” chapter has the dip switch settings to provide TDUV from 0.2 to 2 seconds. IntelliVAC can provide TDUV protection without the use of an external capacitor, as shown in Table 3.D.

Table 3.D – Maximum TDUV Time (*without* Capacitor)

Control Voltage	Max. TDUV Time (secs)
110/120 V	0.2
220/240 V	1.0

The following conditions will initiate TDUV protection, regardless of the supply voltage:

1. If the supply voltage drops below 90 VAC/VDC after the first 200 milliseconds after a contact close request.
2. When the supply voltage drops below 72 VAC/FDC after the 200 millisecond close sequence.

If the undervoltage condition persists beyond the set delay time, the contactor will be opened and an undervoltage fault condition will occur.

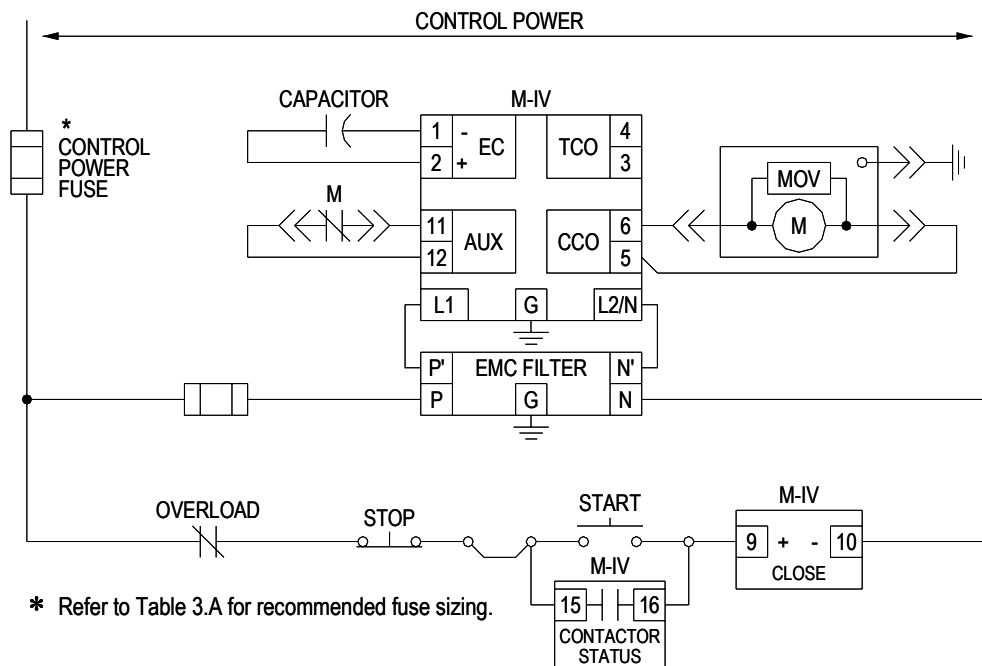

Figure 3.15 – TDUV Control Circuit

Setup and Commissioning

IntelliVAC Configuration

The IntelliVAC module is configured for a specific application by setting DIP switches. They are accessed by loosening the two screws on the front of the unit, and removing the cover by sliding it forward. The switches are found on the front edge of the IntelliVAC circuit board (see Figure 4-1). There are 12 switches, with number 1 being at the top next to the mini DIN connector. (Refer to Table 4.B).

IMPORTANT

Remove power from the module before removing the cover and before changing the DIP switch settings. The new settings are recognized only on power-up.

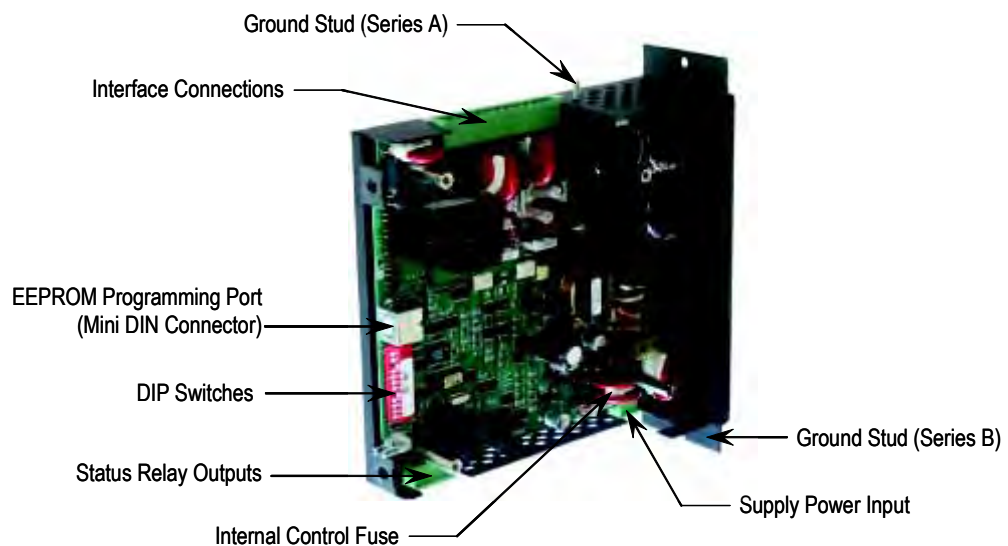

Figure 4.1 – DIP Switch and Connector Locations

An IntelliVAC unit shipped separately from the factory will have a default configuration per Table 4.A.

Table 4.A – DIP Factory Default Settings

Description	DIP switch											
	1	2	3	4	5	6	7	8	9	10	11	12
Altitude: 0 – 1000m	0	0	1									
Drop-out time: 130 msec				0	1	1						
Contactora config.: 400A EH							0	1				
TDUV config.: No TDUV									0			
Ext. cap TDUV time: 0.2 sec										0	0	
*Power-Up Safety: Enable												0

IntelliVAC Configuration (cont.)

IntelliVAC units shipped in a complete MV controller (Bulletin 1500/1900) will be configured to suit the installed application (i.e. contactor type). The user should verify the settings before energizing the equipment. Table 4.B defines the settings for each switch.

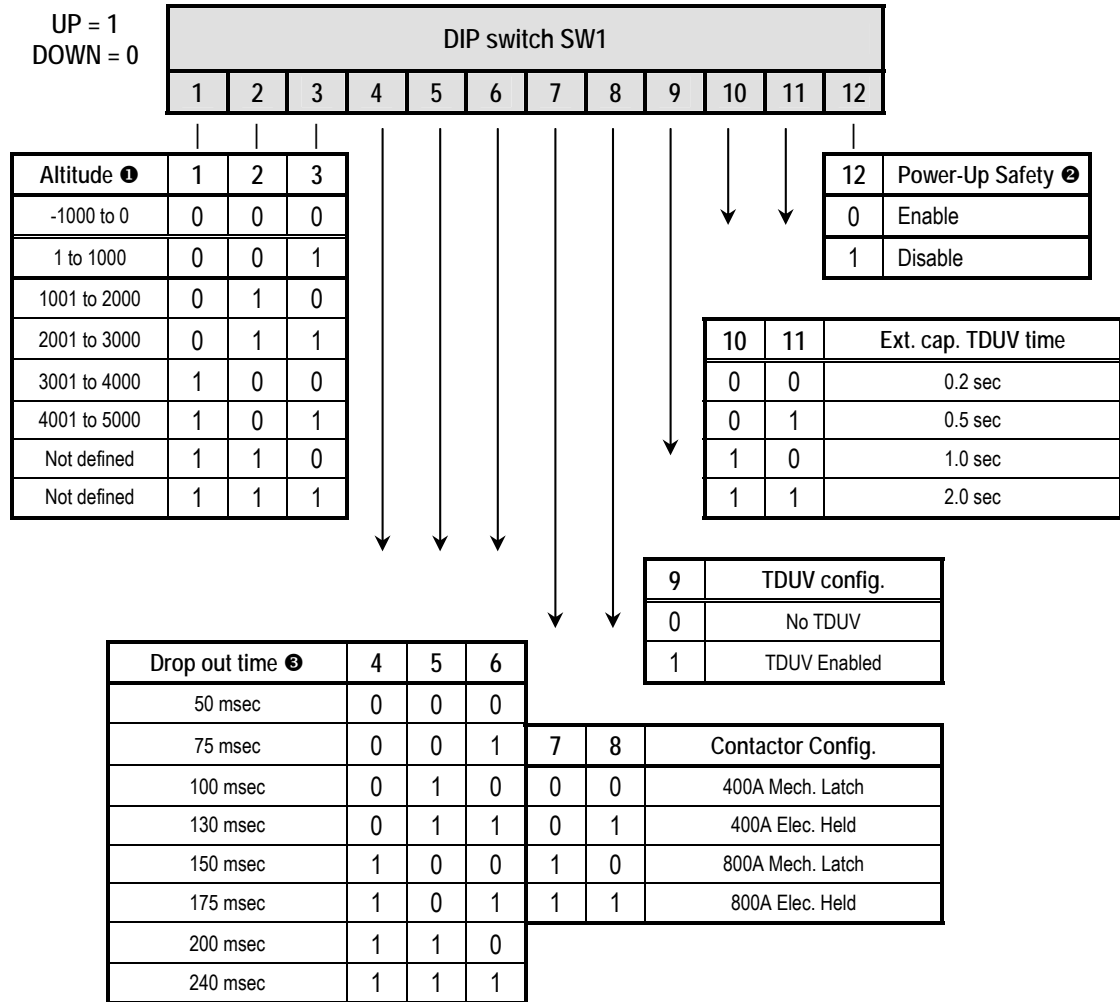

- ❶ The altitude compensation by DIP switch settings applies to Series E 400 amp vacuum contactors only. All 800 amp contactors are adapted for altitude by altering the return springs. 800 amp contactors are to be set for 1 to 1000m (001 DIP setting).
- ❷ Available with IntelliVAC using version 2.001 firmware or newer.
- ❸ By-pass contactors in MV SMC applications must be set for 50 millisecond drop-out time. Refer to Appendix A for typical drop-out time settings used when power fuses are provided by Rockwell Automation.

Monitoring and Troubleshooting

Introduction

The IntelliVAC module has two light emitting diodes (LEDs) and relay outputs to indicate the status of the contactor and the module. The LEDs are visible on the front of the module and the relay outputs are accessed on the bottom front of the module.

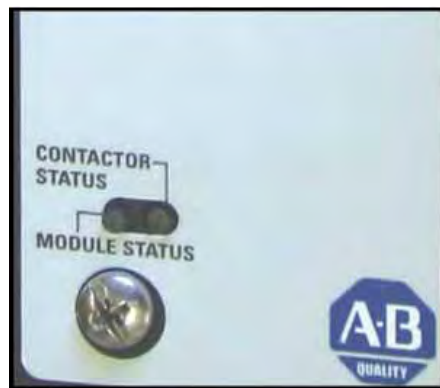

Figure 5.1 – IntelliVAC LEDs

Module Status

The Module Status is indicated with a Green LED if the module is functioning properly and has a valid configuration. If the module powers up with an invalid configuration the LED will be Red, indicating a Fault condition which will not allow the contactor to close. If the module powers up properly and experiences an undervoltage condition when attempting to close the contactor or while the contactor is closed, the LED will be Red (Fault). If the contactor does not close properly, a Fault is generated, the LED turns Red, and inputs are inhibited until the module power is removed and reapplied. If the processor has an internal fault, the LED will be Red, the outputs will be cleared, and the processor will be reset. If the reset is successful, the LED will be Green and the module will respond to the control inputs. The input command must be toggled before the module will respond to a new command (rising edge triggered).

Module Status output relay has a normally open contact. The contact is open during a Fault condition (LED red), and closed during a healthy condition (LED green).

The module states for Series A are summarized in Table 5.A.

Series B Design

Additional module states are indicated with the LED as per Table 5.B.

Contactor Status

The Contactor Status is indicated with a yellow LED that is off until a CLOSE command is received. The LED will stay on if the contactor closes properly, until the contactor is opened.

Contactor Status output relay has a normally open contact. The contact is open when the contactor is open (LED off), and closed when the contactor has received a close command (for 200 milliseconds) or if it is closed (LED on).

Series B Design

Additional module states are indicated with the LED as per Table 5.B.

Table 5.A – IntelliVAC Status Indication (Series A design)

Parameter	Conditions	LED State	Relay Contact State
Module Status ②	<ul style="list-style-type: none"> rated supply voltage and valid configuration 	Green	Closed
	<ul style="list-style-type: none"> undervoltage or contactor fault or invalid configuration ① or internal fault 	Red ②	Open
	<ul style="list-style-type: none"> insufficient supply voltage 	Off	Open
Contactor Status	<ul style="list-style-type: none"> rated supply voltage and close command present ④ and contactor closed 	Yellow	Closed
	<ul style="list-style-type: none"> insufficient supply voltage or close command absent ④ or contactor open 	Off	Open

- ① Applies only to power-up condition.
- ② Fault is reset by cycling control power.
- ③ If a contactor close command is applied and then removed in less than 500 milliseconds, the IntelliVAC may fault and the module status LED will turn red. To clear the fault, module power has to be removed and reapplied.
- ④ For mechanical latch contactors a close command does not need to be maintained for the contactor to remain closed (resulting in a yellow state for contactor status).

Table 5.B – IntelliVAC Status Indication (Series B design)

Conditions ① ②	Description	Module Status		Contactor Status	
		LED Color	Relay	LED Color	Relay
Normal	Healthy Module and Contactor OPEN	Green	Closed	Off	Open
Normal	Healthy Module and Contactor CLOSED	Green	Closed	Yellow	Closed
Warning	Invalid Command Present ⑦	Yellow	Closed	Off	Open
Warning	Mechanical Latch Fail to Trip	Yellow	Open	Yellow	Closed
Fault	Power Up with Contactor CLOSED	Red – Flash 2 ④	Open	Yellow	Closed
Fault	Contactor Fails to Pick Up	Green	Open	Red – Flash 1 ③	Open
Fault	Contactor Drop Out During Hold	Green	Open	Red – Flash 2 ④	Open
Fault	Long Contactor Drop Out Time	Green	Open	Red – Flash 3 ⑤	Open
Fault	Microcontroller Malfunction	Red	Open	Red	Open
Fault	Power Up with Invalid Dip Switch Configuration	Red – Flash 1 ③	Open	Off	Open
Fault	Undervoltage with a CLOSE Command Present	Red	Open	Off	Open

- ① Warning = Recoverable Condition – Remove and retry offending signal
- ② Fault = Non-recoverable condition – Module power must be removed and re-applied.
- ③ Flash 1 = 1 Flash Red LED followed by a pause.
- ④ Flash 2 = 2 Consecutive Red LED flashes followed by a pause.
- ⑤ Flash 3 = 3 Consecutive Red LED flashes followed by a pause.
- ⑥ EH = Only for Electrically Held Contactor
- ⑦ Invalid Command Types:
1. Close, Jog or Trip commands present during power up sequence.
 2. Close or Jog command re-applied too quickly (before contactor opening sequence is verified).
Allow at least 60 msec, plus drop out delay time, before re-applying these signals.
NOTE: Contactor will only respond to a close command re-applications after the re-start delay timer has expired.
 3. Close and Trip commands present simultaneously (valid with Mechanical Latch contactors only).

Table 5.C – Module Troubleshooting

Problem or Trip Indicated	Indication of the following conditions	Possible Solutions
<p>Contactor does not energize</p>	<ul style="list-style-type: none"> • Motor Protection activated • Both Status LEDs 'Off' 	<ul style="list-style-type: none"> • Investigate and reset • Check Control Power • Loose connections in control circuit • Verify IntelliVAC power input plug is in place and properly seated • Verify internal control fuse has not opened (Refer to Figure 4.1 for location)
	<ul style="list-style-type: none"> • Module Status LED 'Red' upon power up (Series A) 	<ul style="list-style-type: none"> • IntelliVAC faulted. Cycle control power to reset. Replace IntelliVAC if unsuccessful.
	<ul style="list-style-type: none"> • Module Status LED 'Red' upon power up (Series A) • Module Status 'Red Flash 1' upon power up (Series B) 	<ul style="list-style-type: none"> • Improper setting of dip switches. Check settings and cycle control power.
	<ul style="list-style-type: none"> • Loose connection in control circuit. 	<ul style="list-style-type: none"> • Verify contactor auxiliary set up. Reference Publication 1502-UM052A-EN-P (400A) or 1502-UM051B-EN-P (800A) – Auxiliary Contact Set-up Procedure. • Verify circuit continuity (is contactor plug connected properly?)
<p>Contactor closes momentarily and will not reclose.</p>	<ul style="list-style-type: none"> • Module status LED 'Red' and Contactor Status LED 'Off' (Series A) 	<ul style="list-style-type: none"> • Coil damaged or connections are loose. Repair and cycle control power. • Auxiliary Contact Assembly improperly adjusted. Reference Publication 1502-UM052A-EN-P (400A) or 1502-UM051B-EN-P (800A) – Auxiliary Contact Set-up Procedure. Cycle control power to reset. • Undervoltage fault (no TDUV), control voltage dipped below trip point. Cycle control power to reset. Verify voltage levels are 110 to 240 VAC, 110 to 250VDC
	<ul style="list-style-type: none"> • Module status LED 'Red' and Contactor Status LED 'Off' (Series A) • Module status LED 'Green' and Contactor Status LED 'Red Flash 1' (Series B) 	<ul style="list-style-type: none"> • Armature Plate obstructed from closing to coil face. Verify no foreign material behind the armature plate. Cycle control power to reset.
	<ul style="list-style-type: none"> • Both status LEDs 'Off' 	<ul style="list-style-type: none"> • Check internal control fuse. Verify IntelliVAC operation in test mode before applying Medium Voltage. (Refer to Fig. 4.1 for location.)

Table 5.C – Module Troubleshooting (cont.)

Problem or Trip Indicated	Indication of the following conditions	Possible Solutions
Contactor opens during operation	<ul style="list-style-type: none"> Motor Protection activated 	<ul style="list-style-type: none"> Investigate and reset.
	<ul style="list-style-type: none"> Stop command initiated 	<ul style="list-style-type: none"> Verify circuit
	<ul style="list-style-type: none"> Module Status LED 'Red' 	<ul style="list-style-type: none"> Undervoltage fault (no TDUV), control voltage dipped below trip point. Cycle control power to reset. Verify voltage levels are 110 to 240 VAC, 110 to 250 VDC. With external capacitor and TDUV feature activated, undervoltage condition for longer than programmed TDUV time. Undervoltage fault activated. Cycle control power to reset.
	<ul style="list-style-type: none"> Module Status LED 'Green' and Contactor Status LED 'Red Flash 2' (Series B only) 	<ul style="list-style-type: none"> Contactor Status feedback between Terminals 11 and 12 on the IntelliVAC has closed. The IntelliVAC will de-energize the coil, thinking the contactor has opened for other reasons.
Contactor does not open (mechanical latch only)	<ul style="list-style-type: none"> Both status LEDs 'Off' 	<ul style="list-style-type: none"> Check control voltage and internal control fuse. (Refer to Figure 4.1 for location.)
	<ul style="list-style-type: none"> Module Status LED 'Red' and Contactor Status LED 'Yellow' (Series A, with firmware 2.001 or newer) 	<ul style="list-style-type: none"> Check control power to ensure that it has not dipped below minimum (see Table 5.D).
	<ul style="list-style-type: none"> Module Status LED 'Yellow' and Contactor Status LED 'Yellow' (Series B, with firmware 2.001 or newer) 	<ul style="list-style-type: none"> Trip mechanism is damaged. Inspect and replace if needed. Check for loose connections in the control circuit.

Refer to Tables 5.A or 5.B for definition of Module LED states.

Table 5.D – Minimum IntelliVAC Operational Supply Voltages

Voltage Level	Contactor Rating (Amps)	Minimum Voltage (VAC, 47 to 63 Hz)
Pick-Up	400/800	95
Drop-Out	400/800	75
Trip (Mechanical Latch)	400	70
	800	80

(This page is intentionally left blank.)

Spare Parts

Spare Parts List

IntelliVAC (electrically held) Series A	1503VC-BMC1
IntelliVAC (mechanical latch) Series A	1503VC-BMC2
IntelliVAC (electrically held and mechanical latch) Series B	1503VC-BMC3
Internal Fuse: 6.3 A, 250 V (Littlefuse 21506.3)	80174-902-14-R
Multi-pole connectors:	
2 pole (module power)	80174-014-01-R
4 pole (status outputs)	80174-014-03-R
12 pole (coil and I/O connections)	80174-014-11-R

Optional Equipment

TDUV Capacitor*	
For 110/120V AC control (1650 μ F)	80158-779-51-R
For 220/240V AC control (330 μ F)	80158-779-52-R

*Includes mounting bracket and terminal guards

EMC Filter	
Schnaffer (FN 670-10/06)	80026-430-01-R

Typical Contactor Drop-out Times

The contactor drop-out times shown in the following table are typical values used when the power fuses are provided as part of a complete MV controller from Rockwell Automation. The recommendations are based on Ferraz Shawmut power fuses. Other fuse types may require alternate drop-out time settings.

Table A.1 – Contactor Drop-out Times

Fuse Rating		Contactor Drop-out Time (msec)		
Voltage	Current	400A	800A	
< 5000	2R	50	50	
	3R			
	4R			
	6R			
	9R			
	12R			
	18R			
	19R			
	24R			100
	32R			240
	38R	❶		
	48X	❶	75	
	57X	❶	200	
	2 x 24R	❶	100	
2 x 32R	❶	240		
2 x 38R	❶	240 *		
< 5000	20E	50	50	
	30E			
	40E			
	50E			
	65E			
	80E			
	100E			
	125E			
	150E			
	175E			
	200E			
	250E			
	300E			
	350E	75		
	400E	100		
	450E	130		
	500E	❶		
600E	❶	75		
750E	❶	200		
900E	❶	240 *		

❶ Fuse not suitable for use with 400A contactor.

Table A.1 – Contactor Drop-out Times (cont.)

Fuse Rating		Contactor Drop-out Time (msec)	
Voltage	Current	400A	800A
7200	2R	50	50
	3R		
	4R		
	6R		
	9R		
	12R		
	18R	75	
	24R	150	
	2X18R	❶	
2X24R	❶	130	
8250	20E	50	50
	30E		
	40E		
	50E		
	65E		
	80E		
	100E		
	125E		
	150E		
	175E		
	200E		

❶ Fuse not suitable for use with 400A contactor.

Note: The drop-out time is chosen to be equal to or greater than the intersection of the rated contactor interrupting current and the fuse melt time curve (except where noted *)

www.rockwellautomation.com

Power, Control and Information Solutions Headquarters

Americas: Rockwell Automation, 1201 South Second Street, Milwaukee, WI 53204-2496 USA, Tel: (1) 414.382.2000, Fax: (1) 414.382.4444

Europe/Middle East/Africa: Rockwell Automation, Vorstlaan/Boulevard du Souverain 36, 1170 Brussels, Belgium, Tel: (32) 2 663 0600, Fax: (32) 2 663 0640

Asia Pacific: Rockwell Automation, Level 14, Core F, Cyberport 3, 100 Cyberport Road, Hong Kong, Tel: (852) 2887 4788, Fax: (852) 2508 1846

Medium Voltage Products, 135 Dundas Street, Cambridge, ON, N1R 5X1 Canada, Tel: (1) 519.740.4100, Fax: (1) 519.623.8930, www.ab.com/mvb

Publication 1503-UM051D-EN-P – June 2013
Supersedes Publication 1503-UM051C-EN-P – January 2006

Copyright © 2013 Rockwell Automation, Inc. All rights reserved. Printed in Canada.