

**Allen-Bradley**

## Safety Lockout System

Bulletin 1000

User Manual

**Rockwell  
Automation**

## Important User Information

Because of the variety of uses for the products described in this publication, those responsible for the application and use of this control equipment must satisfy themselves that all necessary steps have been taken to assure that each application and use meets all performance and safety requirements, including any applicable laws, regulations, codes and standards.

The illustrations, charts, sample programs and layout examples shown in this guide are intended solely for purposes of example. Since there are many variables and requirements associated with any particular installation, Allen-Bradley does not assume responsibility or liability (to include intellectual property liability) for actual use based upon the examples shown in this publication.

Allen-Bradley publication SGI-1.1, *Safety Guidelines for the Application, Installation and Maintenance of Solid-State Control* (available from your local Allen-Bradley office), describes some important differences between solid-state equipment and electromechanical devices that should be taken into consideration when applying products such as those described in this publication.

Reproduction of the contents of this copyrighted publication, in whole or part, without written permission of Rockwell Automation, is prohibited.

Throughout this manual we use notes to make you aware of safety considerations:

---

### ATTENTION



Identifies information about practices or circumstances that can lead to personal injury or death, property damage or economic loss.

---

Attention statements help you to:

- identify a hazard
- avoid a hazard
- recognize the consequences

---

### IMPORTANT

Identifies information that is critical for successful application and understanding of the product.

---

## European Communities (EC) Directive Compliance

If this product has the CE mark it is approved for installation within the European Union and EEA regions. It has been designed and tested to meet the following directives.

### EMC Directive

This product is tested to meet the Council Directive 89/336/EC Electromagnetic Compatibility (EMC) by applying the following standards, in whole or in part, documented in a technical construction file:

- EN 50081-2 EMC — Generic Emission Standard, Part 2 — Industrial Environment
- EN 50082-2 EMC — Generic Immunity Standard, Part 2 — Industrial Environment

This product is intended for use in an industrial environment.

### Low Voltage Directive

This product is tested to meet Council Directive 73/23/EEC Low Voltage, by applying the safety requirements of EN 61131-2 Programmable Controllers, Part 2 — Equipment Requirements and Tests. For specific information required by EN 61131-2, see the appropriate sections in this publication, as well as the Allen-Bradley publication Industrial Automation Wiring and Grounding Guidelines For Noise Immunity, publication 1770-4.1.

This equipment is classified as open equipment and must be mounted in an enclosure during operation to provide safety protection.

**Notes:**

<b>Preface</b>	Purpose of the Safety Lockout System . . . . .	<b>Preface-1</b>
	Safety Requirements and Guidelines . . . . .	<b>Preface-1</b>
	Definitions . . . . .	<b>Preface-1</b>
	Description of Use . . . . .	<b>Preface-2</b>
	Simplified Wiring Diagram and Sequence of Operation . . . . .	<b>Preface-2</b>
	Application . . . . .	<b>Preface-4</b>
	Specifications . . . . .	<b>Preface-4</b>
<b>Chapter 1</b>	<b>Installation Instructions</b>	
<b>Chapter 2</b>	<b>Commissioning Box and Switch</b>	
<b>Chapter 3</b>	<b>Operational Procedure</b>	
	Component Function and Description . . . . .	<b>3-1</b>
	Servicing . . . . .	<b>3-3</b>
<b>Chapter 4</b>	<b>SLS Sequence of Operation</b>	
<b>Chapter 5</b>	<b>Troubleshooting Guide</b>	
	Troubleshooting Guide . . . . .	<b>5-1</b>
	SLS Test Procedure . . . . .	<b>5-3</b>
<b>Appendix A</b>	<b>Certification Documentation</b>	
<b>Appendix B</b>	<b>References</b>	

## Notes:

## Purpose of the Safety Lockout System

The purpose of the Safety Lockout System (SLS) is to provide a highly reliable and long-lived system for the isolation of a multi-motor machine (or portion thereof) with such isolation operable from multiple remote locations.

## Safety Requirements and Guidelines

The SLS is one subsystem in the machine control system. As is true in installing any machine control system, it is necessary to follow the instructions that accompany the control system. It is further necessary to follow the requirements of the relevant regulatory bodies. These can include NFPA 70 (The National Electrical Code), NFPA 70E, NFPA 79, relevant OSHA requirements and relevant State and Local codes.

- EN 50081-2 EMC — Generic Emission Standard, Part 2 — Industrial Environment
- EN 50082-2 EMC — Generic Immunity Standard, Part 2 — Industrial Environment

## Definitions

Safety lockout system (SLS) — Isolation system designed to meet lockout/tagout requirements by the use of remote lockout switches, voltage supervision monitor and an isolation contactor having positive guided auxiliary contacts.

SLS box — SLS enclosure and components other than the SLS switches.

SLS switch — remote lockout switch with verification light.

Expansion box — provisions for more than four (4) SLS switches.

Positive guidance — per IEC 947-5-1 is a performance relationship between contacts of different types (i.e., N.O. and N.C.)

## Description of Use

The SLS switch should not be used to initiate normal stopping of the system. The normal system stop function(s) should be used to stop the system and then, when necessary, the remote SLS switch can be used to initiate the isolation of the system. When the SLS switch is operated for the purpose of isolation, a white SAFE light will illuminate when the system is isolated. The illumination of the SAFE light is the control indication that the electrical power to the equipment on the machine fed through the SLS is de-energized and isolated.

An SLS service technician must investigate, correct and log any abnormality.

## Simplified Wiring Diagram and Sequence of Operation

After using the normal stop function, the machine operator can turn the SLS switch from the ON to the OFF position and then lock the SLS switch in the OFF position. This will cause the isolation contactor (IC) to drop out and arm the SAFE pilot light. The voltage supervision relay (VSR) will then monitor the load side of the isolation contactor for voltages greater than 10V and will monitor the position of the isolation contactor through its normally closed positively guided auxiliary contact. If the voltage check is OK and the IC auxiliary contact is closed, the VSR's safety contacts will close, illuminating the SAFE pilot light.



Figure P.1 Typical SLS System Layout

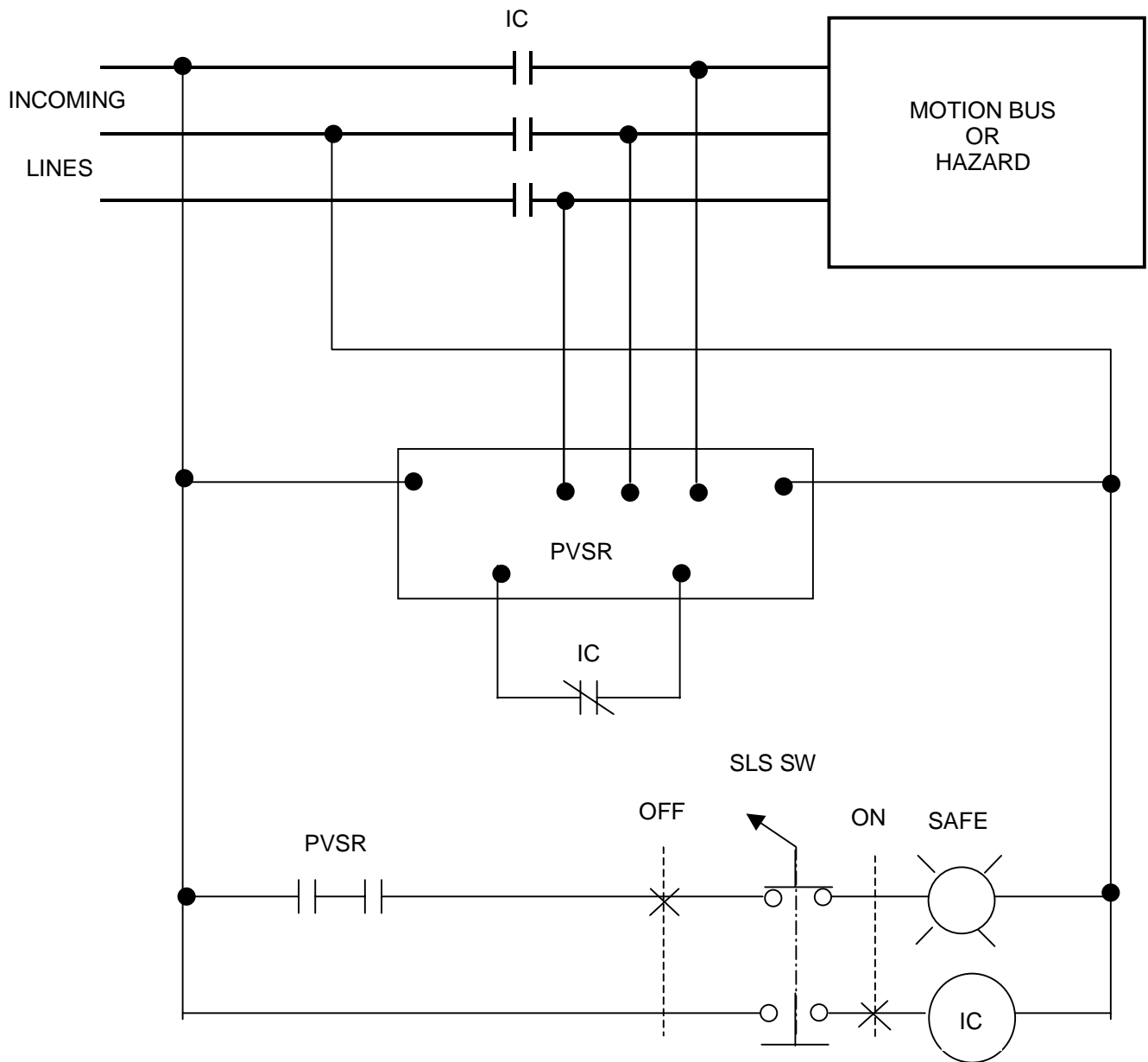
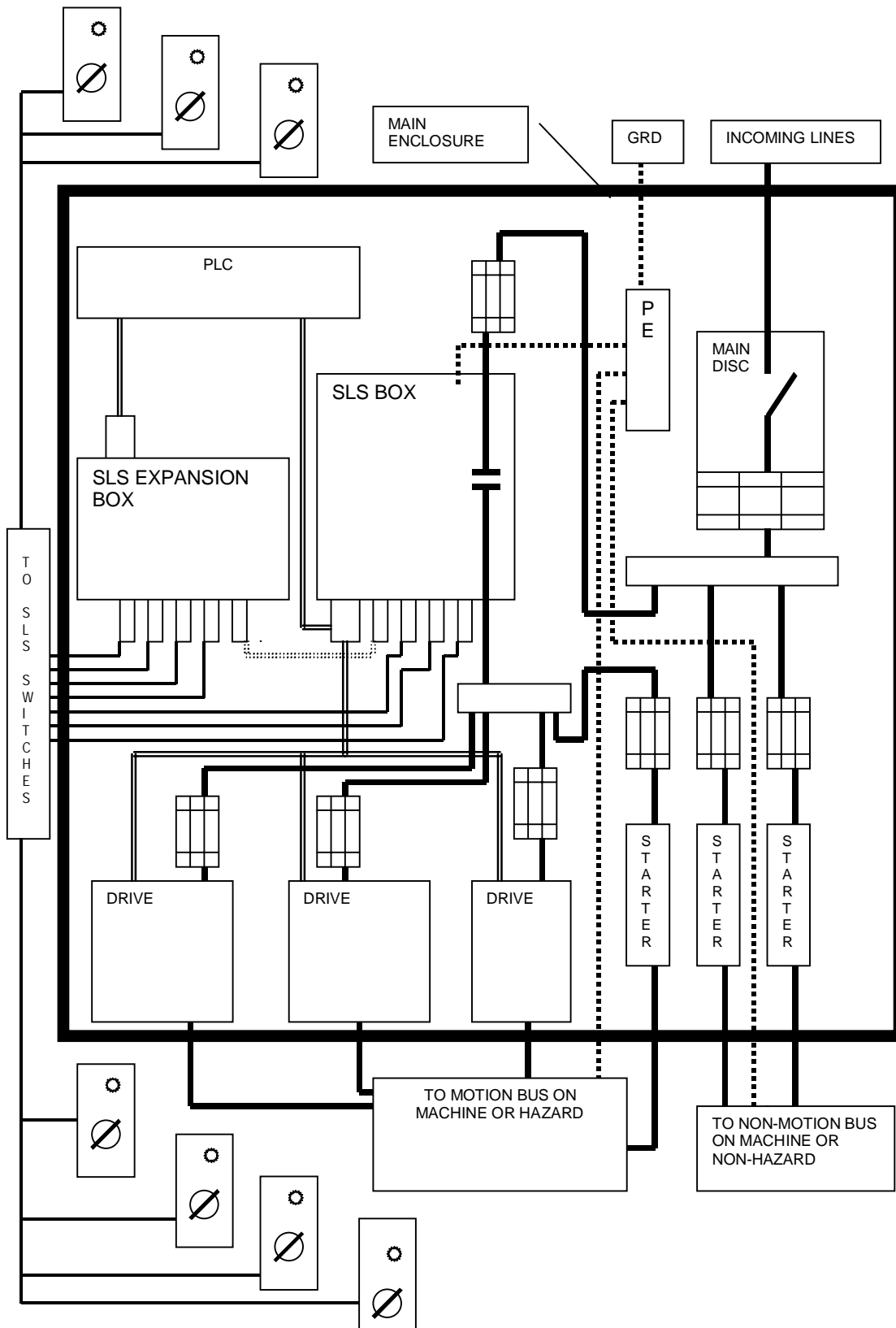


Figure P.2 Typical SLS System Layout



## Application

The SLS is an isolation system designed to provide disconnection and isolation. This means that the SLS provides the isolation necessary for work on machine elements electrically powered through the SLS and for work on the electrical equipment powered by SLS. However, the forgoing speaks to the capability of the SLS, not necessarily its use as assigned by management for a given purpose.

Since the SLS illuminates the SAFE light, it is imperative that the SLS be applied only where it disables all forms of energy and after a risk analysis has been performed.

## Specifications

### A. Electrical Ratings

- Supply Voltage 480V, 60 Hz and 400V, 50 Hz
- Contactor Ampacity 30, 85  
(in conformance with clause 5.7.1 of NFPA 79: 1997, and clause 4.3.2 of EN 60204-1: 1997)

### B. Estimated system life

- SLS box
  - Electrical 1,000,000 operations
  - Mechanical 10,000,000 operations
- SLS switch
  - Electrical 200,000 operations
  - Mechanical 200,000 operations

### C. Environmental

- Storage temperature  $-30 \dots +85^{\circ}\text{C}$
- Operating temperature, Ambient  $-10 \dots +40^{\circ}\text{C}$
- Relative humidity, Non-Condensing 90% RH

### D. Electromagnetic Interference

Compliant with EMC Directives

### E. Reliability

System reliability is indicated by FMEA analysis.

### F. Safety Lockout System

Certified by TUV (Northbrook, IL) for category 4 EN 954-1: 1996, and EN 60204-1

### **G. Construction**

The SLS box enclosure is primarily provided to prevent tampering with the SLS components and circuitry and, as such, is designed and listed per UL 508A to be installed inside another enclosure. The SLS box is constructed with a large transparent viewing window in the cover necessary to easily observe the status of the LED indicators. Both the SLS box and the SLS switch are provided with special holes placed to accommodate tamper-resistant sealing.

### **H. Construction Rating (for SLS switch only)**

NEMA4/IP65

## Installation Instructions

- A.** The SLS box enclosure has no environmental rating. Its purpose is to prevent tampering with the safety system and allow viewing of the components. The SLS box shall be mounted in a parent enclosure of suitable environmental rating with sufficient space to allow free opening of its door and convenient wiring of its connectors.
- B.** After installation the SLS system must be tested for proper operation and certified as such by a SLS trained service technician, who then seals the SLS box and the SLS switches. The engineer responsible for the process or machine shall keep a service logbook of this and all future servicing. Servicing is to be performed only by SLS qualified technicians.
- C.** SLS cable and cable installation specification
1. Cable must be installed so that it is protected from physical damage. This may require conduit.
  2. Cable must have a shield with a drain wire connected to ground at the SLS box.
  3. Cable insulated for 600V is recommended.
  4. Cable shall have copper conductors only.
  5. Maximum SLS switch circuit length (total length of wire run):
    - #14 AWG (2.5 mm<sup>2</sup>) = 4600 ft (1403 m)
    - #16 AWG (1.5 mm<sup>2</sup>) = 2600 ft (793 m)
    - #18 AWG (0.75 mm<sup>2</sup>) = 1300 ft (397 m)
  6. Individual conductors within a cable shall be color coded or otherwise clearly marked.  
Suggested source and type of cable:  
  
For SLS switches — Alpha wire Xtra-Guard 2 Part #25450/9 for #14 AWG 0.64" O.D., Part #25440/9 for #16 AWG 0.61" O.D., and Part #25430/9 for #18 AWG 0.55" O.D.  
(SLS switch cable must not be run with power conductors.)
- D.** SLS box ground bus must be bonded to the system ground bus in the main enclosure as follows:
1. For 85 A SLS box with Pilz relay (Cat. No. 1000-NXSLSV85) use #8 AWG (10 mm<sup>2</sup>).
  2. For 30 A SLS box with Pilz relay (Cat. No. 1000-NXSLSV30) use #10 AWG (6 mm<sup>2</sup>).

**Note:** If the Class J fuses protecting the SLS box are smaller than that specified, the equipment grounding conductor may be reduced to that as shown in Table 250-95 of the NEC.

- E.** This SLS box has Harting connectors for four SLS switches with safe light (Cat. No. 1000-NXSLS). If less than that four are needed for an installation, jumper out the unneeded SLS switches in the male end of the Harting connector. Refer to wiring diagram Y-155798.

Example: If SLS #4 is not needed, remove the hood on the male Harting SLS connector and install a jumper between pins #3 and #8 on the insert and install another jumper between pins #4 and #9 on the insert. This will jumper out the missing SLS switch #4. Re-install the hood and clamp the male Harting connector back in the SLS #4 position.

- F.** If an installation requires more than four SLS switches, an expansion box(es) can be installed to increase the total number of SLS switches. Refer to drawings Y-156773 and Y-157131.
- G.** The SLS enclosure must be bolted to the mounting plate of an enclosure in the vertical position. Refer to drawing YD-24475 for mounting dimensions.
- H.** The SLS box must be protected upstream from the isolation contactor by a Class J time delay fuse. Maximum available fault current is 42 KA at 480V. In order to ensure IEC 947-4-1 Type 2 or better protection, fuses are to be sized per NEC Article 430 part D, but shall not exceed the following:
  - 85 A contactor size = 100 A max.
  - 30 A contactor size = 30 A max.
- I.** Power wire size and terminal torque

**Table 1.A**

SLS Rating	Cat. No.	Power Wire Size	Terminal Torque
30 A with Pilz relay	1000-NXSLSV30	#14...#6 AWG (2.5...16 mm <sup>2</sup> )	31 lb-in. (3.5 Nm) +0%...5%
85 A with Pilz relay	1000-NXSLSV85	#14...#2 AWG (2.5...50 mm <sup>2</sup> )	52 lb-in. (6 Nm) +0%...5%

- J.** SLS switch installation
  1. Mount in the vertical plane per drawing YD-24492.
  2. Use conduit and hub or strain relief cord grip.
  3. Connect SLS cable to terminal blocks that correspond to the pin numbers on the Harting connectors per drawing Y-156328.

## Commissioning Box and Switch

This procedure is to be followed at first time startup and any subsequent SLS service.

### A. Inspection

1. Visually inspect enclosure and components for damage that may have occurred in installation or shipment. Look for loose wires or damaged components.
2. For first time installation, remove adhesive protective paper cover from SLS box window.
3. Check incoming and outgoing three phase power lines for proper selection and sizing. Select per NEC article 430 part B and size per NEC table 310-16, 75°C column. Note that the preferred wire, MTW, is rated 90°C, but it must be sized per the 75°C column.
4. Check incoming and outgoing lines along with associated line voltage control wires that attach to the isolation contactor for proper torque. Refer to wiring diagram for values. Also check that the lugs do not crimp down on the wire insulation.
5. Check to see that the proper class J time delay fuse is installed ahead of the SLS box. Refer to wiring diagram notes and see [item H](#) under “[Installation Instructions](#)”.
6. Check to see that the proper size grounding conductor has been installed between the ground bus in the main enclosure and the ground bus in the SLS box (refer to [item D](#) under “[Installation Instructions](#)”). Refer to NEC Table 250-66 for sizing.
7. Verify that the SLS switches are connected to the SLS box and that unneeded SLS switches are jumpered out in the Harting connectors as per [item E](#) under “[Installation Instructions](#)”.
8. Inspect SLS cable installation for protection against damage. Refer to [item C](#) under “[Installation Instructions](#)”.
9. If required, check to see that white phenolic nameplate on the SLS switch cover is engraved as specified. Also check to see that screws that secure this nameplate to cover are resealed on the inside of cover when nameplate is replaced. This is to ensure NEMA Type 4 (IP65) watertight construction.
10. Verify that the control transformer primary and secondary is connected per the system voltage per note #4 on wiring diagram Y-155798. Refer to [Appendix A](#).

**B. Verification of SLS operation**

1. Turn all SLS switches to the ON position.
2. Check the machine to see that damage or injury will not occur if the machine is started.
3. Energize the motion bus that the SLS box contactor controls.
4. Check for machine operation and by operating with the normal start and stop functions. Check to see that the signals to the PLC and drive are correct. Leave machine in the stopped mode.
5. Observe LEDs in SLS box for the following conditions:
  - Power supply DC ON = on.
  - VSR — POWER = on.
  - Safety relay 1SR — POWER ON, CH1, CH2, K1, K2 = on.
  - Safety relay SR — POWER ON, CH1, CH2, K1, K2 = on.
  - LED terminal blocks — PLUS = on, 12 = off, MINUS = on.
6. All SLS switch SAFE lights should be off.
7. Check voltage on secondary of CCT.
8. Measure DC voltage on power supply output. If necessary, adjust to 27V.
9. One at a time, check the operation of each SLS switch by turning it to the OFF position. Then check for the following:
  - SAFE light on.
  - IC dropped out.
  - 1CR dropped out (refer to cross bar).
  - Safety relay dropped out, LED — POWER ON = on, CH1, CH2, K1, K2 = off.
  - VSR indicates safe condition. LED — POWER = on, six phase voltages = off.
  - LED T.B. — PLUS = on, 12 = on, MINUS = on

**C.** To provide an indication of tampering, seal the SLS box, the SLS switches and the Harting connectors with a tamper-resistant indicating seal. There are holes in the right hand side of the enclosures for this and in the Harting connectors.

**D.** A service log shall be kept for each SLS box that keeps track of the following:

1. Serial number of SLS box
2. Date of commissioning
3. Name of SLS commissioning technician
4. Name of the SLS service technician
5. Description of service performed
6. Date of service



## Operational Procedure

The machine operator should not use the SLS to perform a normal stop function. The SLS should only be used to isolate the system. Machine access is allowed only after the SLS switch is locked and tagged in the OFF position and the white SAFE light is illuminated to verify that the system is indeed isolated. If the white SAFE light fails to illuminate when the SLS switch is turned to the OFF position, the machine cannot be considered isolated nor safe. The operator should not enter the machine, but should contact a SLS qualified service technician.

### Component Function and Description

Table 3.A SLS Box

Component	Cat. No.	Source	Description	Repairable	Function
Enclosure	32267-121-51	Allen-Bradley	See-through cover		Provides segregation and protection of the SLS components.
Mounting plate	32267-122-02	Allen-Bradley			Mounts equipment.
Control transformer	B075-1017-GA	Micron	480/400 – 120/110V	No	Provides 120V for control circuit.
Primary fuse block	1492-FB2C30-L	Allen-Bradley	Class CC rejection type with blown fuse indication	No	Secures fuse and indicates status.
Primary fuses	KLDR	Allen-Bradley or Littlefuse	Class CC fuse	No	Protects CCT primary.
Secondary fuse block	1492-FB1C30-L	Allen-Bradley	Class CC rejection type with blown fuse indication	No	Secures and indicates status.
Secondary fuse	KLDR	Allen-Bradley or Littlefuse	Class CC fuse	No	Protects CCT secondary.
Power supply	PS5R-C/50W 24V	IDEC	Current limiting 24V DC with LED	No	Provides current limited 24V DC for SLS circuit.
Safety contactor	100S-C85D04C	Allen-Bradley	85 A IEC safety contactor, 120V coil	No	Provides isolation and status through N.C. positive guided auxiliary.
2 N.O. auxiliary	100-SA20	Allen-Bradley	2 N.O. auxiliary	No	Provides control circuits with positive guidance and monitoring of power poles.
Surge suppressor	100-FSC280	Allen-Bradley	120V RC type	No	Absorbs coil spikes.

**Table 3.A SLS Box (Continued)**

Component	Cat. No.	Source	Description	Repairable	Function
Pilz relay	PU3Z 24VDV	Pilz	Voltage supervision and contactor monitoring safety relay	No	Monitors position of contactor and voltage on load side of contactor.
Safety relay SR	700-ZBL220Z24	Allen-Bradley	24V safety relay	No	Checks for cable integrity and for operation of the SLS switch.
Safety relay 1SR		Allen-Bradley	24V safety relay	Yes	Serves as E-stop, pilot relay, and PLC interface.
1CR	700-CF220DJ	Allen-Bradley	24V DC control relay	Yes	Keeps safe light out if the SR safety relay faults.
Protective cover	100-SCCA	Allen-Bradley	Protective cover	No	Prevents manual operation.
Terminal blocks	1492-H1	Allen-Bradley	Terminal blocks	No	Provides connections.
LED terminal blocks	1492-HM2V24	Allen-Bradley	LED terminal blocks	No	Provides indication of voltage presence.
Harting connectors	See Renewal Parts List	Harting	Plug-in connectors	Yes	Provides quick connection and indication of tampering if sealed.

**Table 3.B SLS Switch**

Component	Cat. No.	Source	Description	Repairable	Function
Enclosure	32267-132-51	Allen-Bradley	NEMA Type 4 SS enclosure		Provides protection for SLS components. Allows for tamper indication if sealed.
Mounting plate	32267-133-01	Allen-Bradley			Mounts components
Operating handle	194R-HS4	Allen-Bradley	Lockable position indicating operating handle	No	Operates and provides for lockout. Enclosure cannot be opened when locked out.
Pilot light	800H-QR24W	Allen-Bradley	White 24V DC pilot light	Yes	Signals SAFE.
SLS switch	194E-A25-1753	Allen-Bradley	3-pole disconnect switch	No	Provides redundant signal through safety relay.
SLS switch auxiliary contact	194E-A-P11	Allen-Bradley	Auxiliary contact	No	Provides SLS status to PLC.

## Servicing

- A.** Servicing is only to be performed by qualified SLS technician.
- B.** Due to the nature of this controller and the type of equipment used, most all components are deemed non-repairable and should be replaced (not repaired) if they are not functioning properly.
- C.** Refer to Allen-Bradley wiring diagram Y-156594. This is a schematic for the 700-ZBL220Z24 and should aid in further understanding of the operation of the SLS switches and the safety relays. Refer to [Appendix A](#).
- D.** Reference to renewal parts list.  
  
For renewal parts identification and placement refer to Allen-Bradley document #49103-063-01 (SLS box) and #49000-064-01 (SLS switch). Refer to [Appendix A](#).
- E.** Refer to Allen-Bradley drawing Y-156386 for test set-up.
- F.** The entire SLS box may be returned to the factory for repair and/or testing. Consult your local Allen-Bradley Sales Office regarding a Product Service Report (PSR) to initiate a factory repair.

**Notes:**

## SLS Sequence of Operation

The following is the sequence of operation for the SLS box and the SLS switch as shown on Y-155798 Rev. M and Y-156328 Rev. B. The intention is to provide an understanding of circuit operation and equipment function. This will be an aid in troubleshooting because if the sequence stops or is incomplete, the suspected part or failure may be narrowed down and identified. Assumptions are made that the SLS has been installed properly, no fuses are blown, power is on, all equipment is functioning correctly and all SLS switches are in the ON position

**A. Status**

1. IC is open.
2. Power supply LED is on.
3. Pilz PU3Z power LED on.
4. All SLS switch SAFE lights are off.
5. All safety relay LEDs are on.
6. 1CR is energized (refer to cross bar).
7. Blown fuse pilot lights are off.
8. TB LEDs between + and – are on.

**B. The remote 24V DC signal is applied to 1SR at TB#34 and TB#35 causing it to close the circuit between wires #4 and #5.**

**C. Since the safety relay 1SR is energized and its contacts between #13 and #14 are closed, IC will be energized, actuating the IC auxiliary contacts and sending power to the motion bus.**

**D.** If an operator moves the SLS switch from ON to OFF, the following will happen:

1. The safety relay circuit between terminals S10 and S11, and S21 and S2 will open up to de-energize the safety relay, causing the safety contacts terminals #13 and #14 between wires #1 and #3 to open up. In addition, safety relay auxiliary contacts between terminals #33 and #34 and #43 and #44 will open dropping out 1CR. This will cause IC to open up.

**Note:** If one of the contacts on the SLS switch does not open, or if there is a short in the cable to the SLS switch, only one of the safety relay contacts K1 or K2 will drop out IC. But, the safety relay will lock up and not allow a re-start. Now, since one of the safety relay auxiliary contacts K1 or K2 will remain closed, 1CR will remain energized, preventing the SAFE pilot light from illuminating. Also, if the contacts IC and 1CR between terminals S41 and S42 on the safety relay have not re-closed, the safety relay will not allow a restart.

2. After IC has dropped out, the VSR will check for voltages greater than 10V on the load side of IC through its redundant and broken wire sensing circuit. The VSR will also check to see that the N.C. positively guided auxiliary contact between wire #7 and #8 on IC is closed. If these two conditions are met, the VSR will close the safety contacts between its terminals #13 and #14.
3. Since the auxiliary contact of IC between ++ and wire #10 is closed, the 1CR contact between wires #10 and #11 is closed, the safety contacts between wire #11 and #12 are closed, and the SLS switch contact between wire #12 and the SAFE pilot light is closed, the SAFE pilot light will illuminate. The TB led between wire #12 and – is on.

**E.** The SAFE pilot light will not come on with the SLS switch in the off position if:

1. The VSR detects a voltage greater than 10V on the load side IC.
2. The VSR detects that the positively guided N.C. auxiliary IC contact between wires #7 and #8 has not re-closed.
3. A safety relay auxiliary contact does not allow 1CR to drop out and close circuit between wires #10 and #11.
4. The IC auxiliary contact between wires PLUS and #10 does not re-close.

**F.** If the SLS switch is moved back to the ON position the following will happen:

1. The SLS switch contacts between the safety relay terminals S10 and S11, and S21 and B2 will close to energize the safety relay. This causes the safety contacts between terminals #13 and #14 between wires #1 and #3 to close.

**Note:** The SLS switch contacts must close at approximately the same time or the safety relay will lock up. This may denote an SLS switch or cable failure. Also, the contacts IC and 1CR between terminals S41 and S42 must be closed or the safety relay will not energize. This may indicate a failure of IC, 1CR, the SLS switch or the cable. Plus, safety relay auxiliary contacts between terminals #33 and #34, and #43 and #44 will close energizing 1CR.

2. Since 1SR between wires #4 and #5 is closed along with 1CR between wires #3 and #4, and the safety relay SR output contacts between terminals #13 and #14 are also closed, IC will close its output power contacts.
3. The PVSR will detect a voltage and see that the circuit between terminals Y4 and Y5 is open, causing the safety contacts between terminals #13 and #14 PVSR to open.
4. All contacts in series with the SAFE light should now be open and the SAFE light will now be off. The TB led between wire #12 and – will be off.

**Notes:**



## Troubleshooting Guide

### Troubleshooting Guide

Table 5.A SLS Box

Problem	Component	Possible Cause	Check	Suggested Action	Repairable?
<ul style="list-style-type: none"> <li>Low voltage on secondary</li> <li>Low voltage on primary</li> </ul>	Control transformer	Loose connections, System voltage	Primary wired for proper voltage	Replace if nothing suspicious found.	No
High voltage on secondary		Primary wired wrong	Voltage on input	Replace if nothing suspicious found.	No
Blown fuse indicated	Primary fuses	Overload or short in CCT	For correct wiring or fault in control circuit	Replace CCT if necessary and install correct size fuse as shown on the wiring diagram.	—
Blown fuse indicated	Secondary fuse	Overload or short in CCT	For correct wiring or fault in control circuit	Replace CCT if necessary and install correct size fuse as shown on the wiring diagram.	—
Low DC voltage on load side	Power supply	Overload, low voltage on AC side	Adjust output voltage, Check CCT voltage output.	Replace if defective.	No
Does not pick up	Contactor	Low voltage	Control voltage	—	—
		Open coil	Flash light coil	Replace entire assembled contactor.	No
		Open in coil circuit	Entire coil circuit	—	—
		Foreign material jam	—	Replace entire assembled contactor.	No
Does not drop out		Welded contact or foreign material jam	Coil voltage must be zero.	Replace entire assembled contactor.	No
Continuity or non-operation	Auxiliary contacts	—	Resistance of contacts with wires removed	Auxiliary contacts are locked on the contactor replace entire assembled device.	No
Safety contacts between terminal #13 and #14 will not close and there is no voltage on load side of contactor and IC auxiliary is closed	VSR	Bad relay	Refer to VSR literature and LEDs on front of VSR for status.	Replace VSR.	No

Table 5.A SLS Box (Continued)

Problem	Component	Possible Cause	Check	Suggested Action	Repairable?
Safety contacts between terminals #13 and #14 will not close	Safety relay SR	Bad SLS switch	SLS switch	Replace SLS switch.	No
		Fault, opens or short in SLS cable	SLS cable	Repair or replace cable.	No
		1CR jammed on	1CR for operation	Replace if necessary.	No
		IC jammed on	For operation	Replace entire contactor ass'y.	No
		Power circuit to safety relay open	Power LED off	Reset power supply.	—
		Failed safety relay	LEDs during operation	Replace.	No
	Safety relay 1SR	Power circuit to safety relay open	Power LED off	Reset power supply.	No
		Failed safety relay	LEDs during operation	Replace.	No
Won't pick up	1CR	Open coil	Flash light coil	Replace.	No
		Open circuit to coil	—	—	—
		Welded contacts	—	Replace.	No
Won't drop out		Welded contacts	—	Replace.	No
		Foreign material jam	—	Replace.	No

**Table 5.B SLS Switch**

Problem	Component	Possible Cause	Check	Suggested Action	Repairable?
Does not illuminate with all other circuitry checking OK	Pilot light	Burned out bulb Loose connections	Connections	Replace bulb. Tighten connections.	Yes
Contacts do not operate properly	SLS switch	Bad switch	Continuity and operation	Replace.	No
		Handle mechanism	For operation	Replace.	No
Contacts do not operate properly	SLS switch auxiliary contact	Bad contact	Continuity and operation	Replace.	No

## SLS Test Procedure

If an SLS box needs to be removed from the main control panel, it can be tested as follows.

Wiring diagram: Y-155798 Rev. M = SLS box  
 Y-156328 Rev. B = SLS switch  
 Y-156386 Rev. B = test procedure control panel

In addition to the normal Allen-Bradley test procedure, the following should also be done:

1. Connect test control panel per Y-156386 Rev. B at PLC connector and power test panel with 24V DC separate control.
2. Connect four SLS switches wired per Y-156328 Rev. B.
3. Apply 480V or 400V three-phase to line side of isolation contactor.
4. Turn the four SLS switches to ON position.
5. Energize 1SR with selector switch on test control panel.
6. Observe all LEDs in SLS box for condition. Observe pilot lights on test control panel for condition. SR, 1SR, IC, and 1CR should be energized.
7. All SLS switch SAFE lights should be off.
8. Measure DC voltage on power supply output. If necessary, adjust to 27V.
9. Check voltage on secondary of CCT.

- 10.** One at a time, check operation of SLS switches by turning to OFF position, and check for the following:
  - a. SAFE light on.
  - b. IC dropped out.
  - c. 1CR dropped out.
  - d. Safety relay SR dropped out
  - e. VSR indicates safe condition.
  
- 11.** VSR voltage sensing broken wire detection test.
  - a. With power off, remove one voltage-sensing wire from the VSR. Then, with all SLS switches in the ON position, apply power and turn a SLS switch off. The result should be that the safe light does not illuminate (after cycling an SLS switch) and the system fault LED is on. The VSR voltage hazard LED will now turn on. Turn power off, reconnect voltage sensing wire and repeat check with the VSR redundant voltage sensing circuit.
  - b. Each separately, do the same test with the two N\* circuits. (No initial fault on VSR, only when the SLS switch is turned to off does the system fault light come on.)
  
- 12.** Safety relay cable shorting checks
  - a. With all power off, install a shorting jumper on Allen-Bradley safety relay 700-ZBL between terminals S10 and S11. Then power up the system with all SLS switches in the ON position. Turn a SLS switch to the OFF position. The SAFE light should not come on. Observe that CH2 and K1 LEDs are off on the safety relay. Turn off all power and remove shorting jumper.
  - b. With all power off, install a shorting jumper on Allen-Bradley safety relay 700-ZBL between terminals S21 and B2. Then power up the system with all SLS switches in the ON position. Turn a SLS switch to the OFF position. The SAFE light should not come on. Observe that CH1 and K2 LEDs are off on safety relay. Turn off all power and remove shorting jumper.

- 13. IC contactor monitoring test.**
  - a. With all power off disconnect wire #7 on the IC auxiliary terminal #81.
  - b. Apply power with all SLS switches in the ON position. Turn one SLS switch to OFF. The safe light should not come ON because the VSR contacts K2 and K1 between terminals #13 and #14 should not close. The VSR will not show a fault light.
  - c. Turn off power and reconnect wire # 7 at terminal #81 on the IC contactor auxiliary.
  - d. Apply power and cycle the 4 SLS switches to confirm system operation.
  
- 14. Voltage sensing test.** The object is to determine whether the VSR contacts K2 and K1 between terminals #13 and #14 remain open if a voltage is present on the load side of the contactor.
  - a. To prepare, remove 3-phase power, primary and secondary fusing and apply 120V to wire #1 and #2 to power control circuit. Also, apply 3-phase voltage to load side of contactor.
  - b. All SLS switches in ON position.
  - c. Turn SLS switch (s) to off. With voltage above 10V applied to the load side of contactor, the VSR should show a voltage hazard LED and should not allow a SAFE light to come on.

Test is complete. Disconnect all power, remove metering, remove test SLS switches, install Harting connectors for shipment, remove test control panel, re-install primary and secondary fusing, check for loose connections and check to see if all jumpers are removed.

**Notes:**

## Certification Documentation

- A.** Listed as an open type controller per UL508A
- B.** TUV Reinland verification of FMEA = checking condition of the SAFE light
- C.** Declaration of conformity = CE marked. Self-certified to meet EN 60204-1: 1997
- D.** SUVA letter stating that MCS control devices 1CR and IC have positively guided auxiliary contacts that meet the requirements of IEC 947-5-1
- E.** TUV Reinland certified to meet the requirements of category 4 EN 954-1: 1996 in relationship to the SAFE light

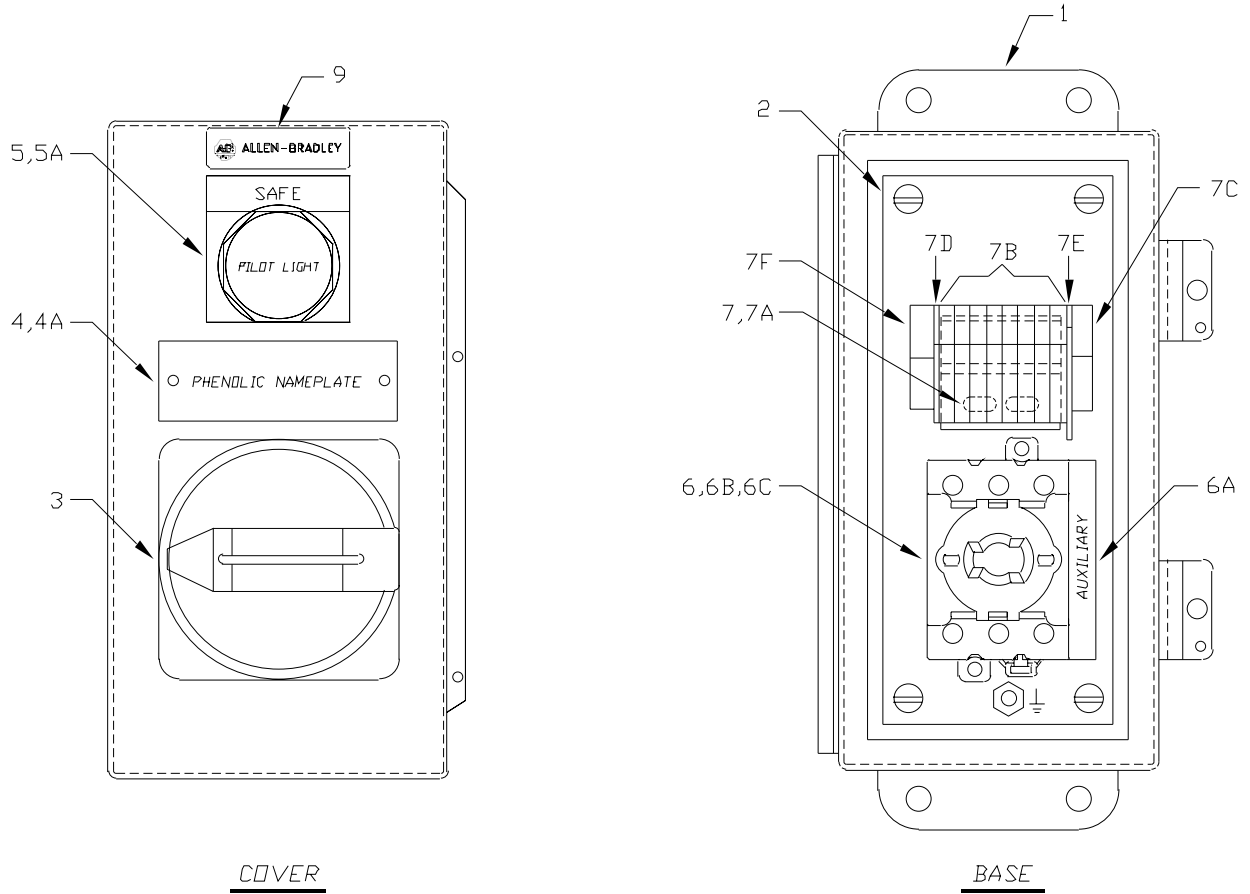
## Documents

Table A.A

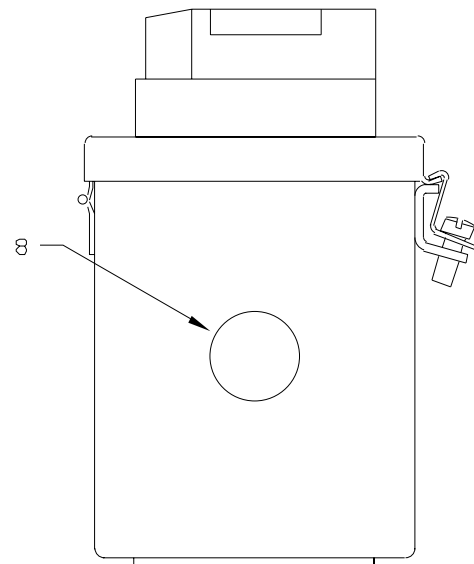
Description	Allen-Bradley Drawing Number	Revision
SLS box wiring diagram	Y-155798 sheet 1, 2, and 3	Rev. M
SLS box dimension drawing	YD-24475	Rev. 5
SLS box renewal parts list	49000-063-01	Rev. 3
SLS switch wiring diagram	Y-156328	Rev. B
SLS switch dimension drawing	YD-24492	Rev. 3
SLS switch renewal parts list	49000-064-01	Rev. 3
Test procedure wiring diagram	Y-156386	Rev. B
Allen-Bradley schematic wiring diagram for 700-ZBL safety relay	Y-156594	Rev. B
SLS box composite assembly	49103-588-01	Rev. D
4 SLS switch expansion box	Y-156773	Consult your local Allen-Bradley Sales Office.
10 SLS switch expansion box	Y-157131	
4 SLS dimensions	—	
10 SLS dimensions	—	
LED explanation sheet	49000-082-01	Rev. A

# Diagrams

Figure A.1 Bulletin 194E SLS Switch Renewal Parts



NOTE-ADD .187 DIA. HOLE IN MTG. RAIL ITEM 7A AND CORRESPONDING .136 DIA. #8-32 TAPPED HOLE IN STAND-OFF ITEM 7 TO PREVENT TURNING.

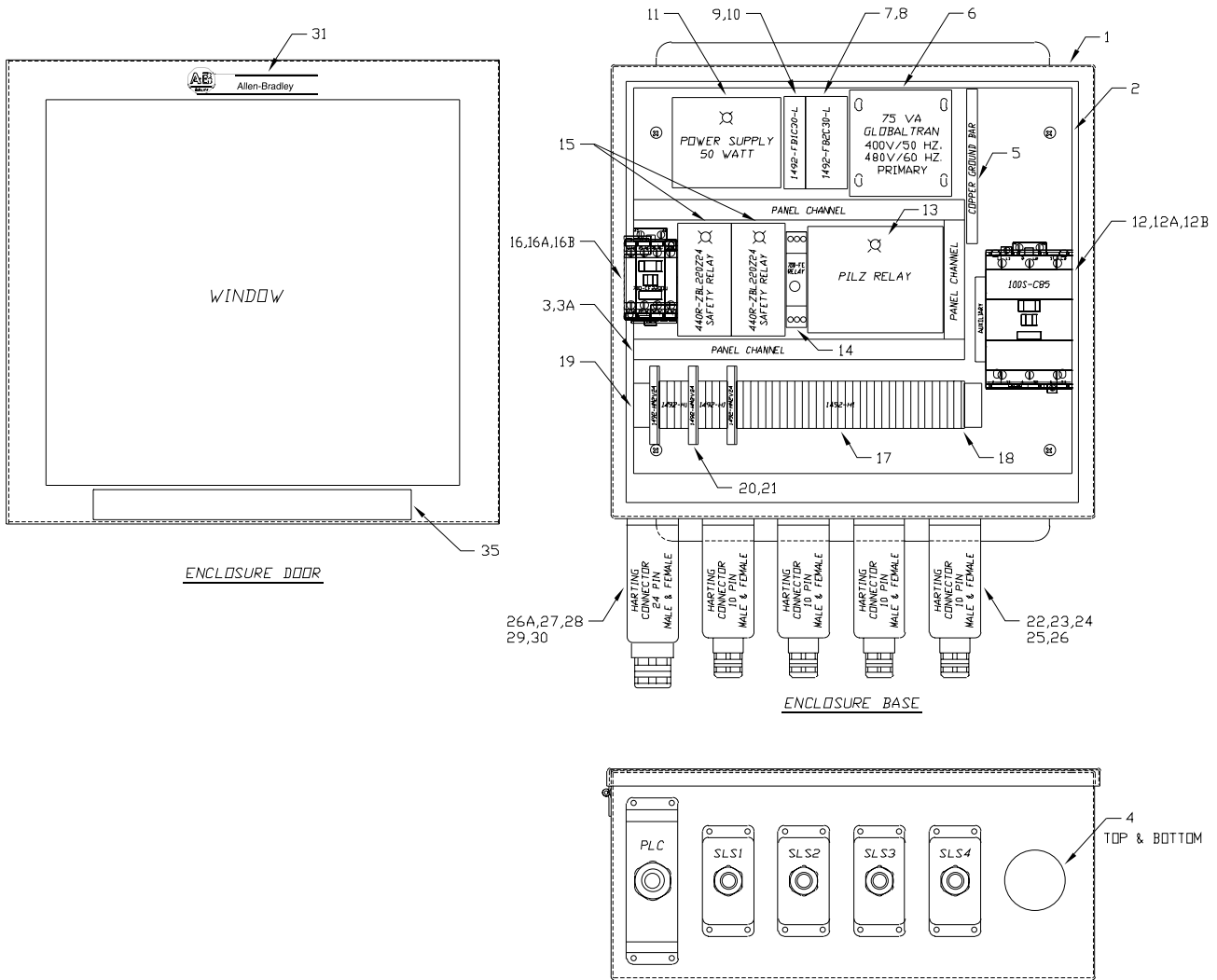




**Table A.B Bulletin 194E SLS Switch Renewal Parts**

<b>Item</b>	<b>Description</b>	<b>Part Number</b>	<b>Amount</b>
1	A-B Enclosure	32267-132-51	1
2	A-B Mounting Plate	32267-133-01	1
3	194R Operating Handle — Black	194R-HS4	1
4	Phenolic Nameplate	H-26553	1
4A	#4-40 x 0.187 Pan Hd. Stain. St. Screw	28010-068-01	2
5	800H Pilot Light	800H-QR24W	1
5A	800H Nameplate Engrv. SAFE	800H-W100E	1
6	194E 25 A Load Switch	194E-A25-1753	1
6A	194E Auxiliary Contact 1 N.O. - 1 N.C.	194E-A-P11	1
6B	194E Adapter Kit	194E-G3675	1
6C	A-B Operating Shaft	31013-314-01	1
7	Terminal Block Stand-Off (See Note)	40164-416-01	1
7A	Terminal Block Mtg. Rail (See Note)	1492-DR3	1
7B	Terminal Blocks	1492-WM3	8
7C	Grounding Terminal Block	1492-WMG3	1
7D	End Barrier	42164-017-01	1
7E	Partition Plate	1492-PPM3	1
7F	End Anchor	1492-EA15	1
8	Cap Plug	28470-007-01	1
9	Trademark Plate	H-18742	1
10	Wiring Diagram	Y-156328 Rev. B	1

**Figure A.2 Bulletin 100, 85 A SLS Box with Pilz Relay (Cat. No. 1000-NXSLSV85) Renewal Parts**



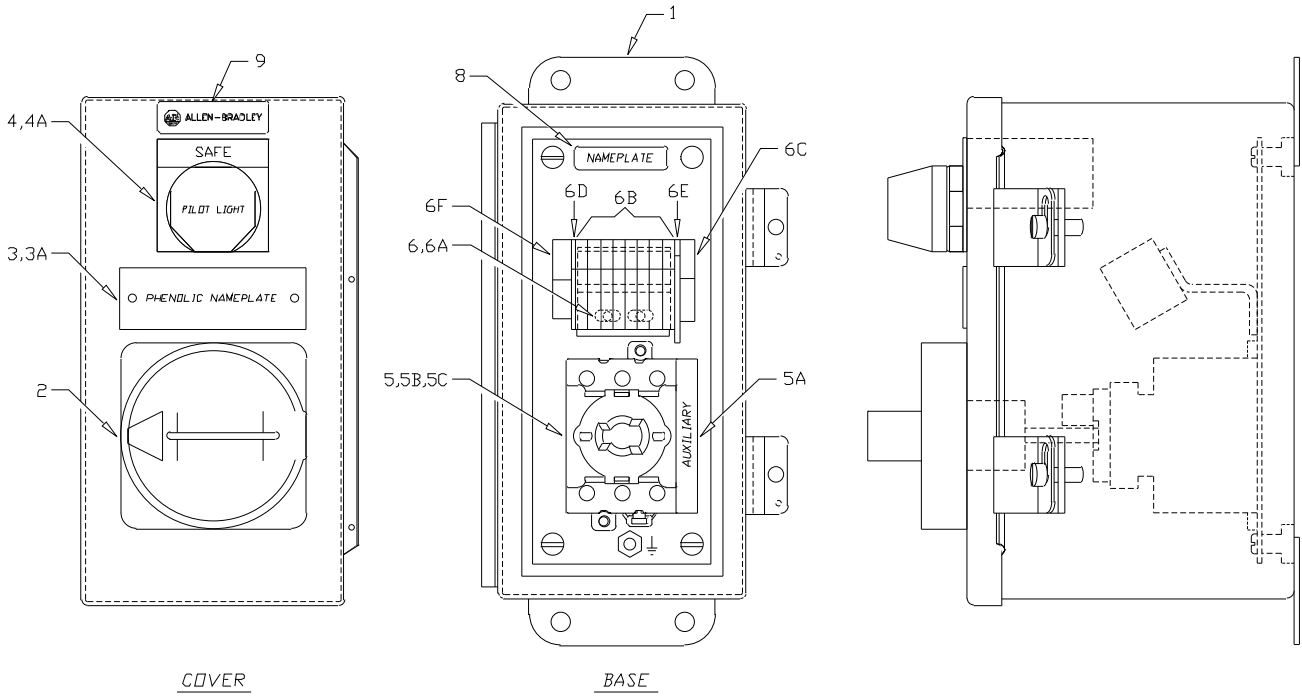
**Table A.C Bulletin 100, 85 A SLS Box with Pilz Relay (Cat. No. 1000-NXSLSV85) Renewal Parts**

Item	Description	Part Number	Amount
1	A-B Enclosure	32267-121-51	1
2	A-B Mounting Plate	32267-122-02	1
3	Panduit Panel Channel	E.5x2WH6	1
3A	Panduit Cover	C.5WH6	1
4	Heyco Bushing	SB-200-26	2
5	Ground Bus	N70-12-1	1
6	Micron Transformer	B075-1017-GA	1
7	Primary Fuse Block	1492-FB2C30-L	1

**Table A.C Bulletin 100, 85 A SLS Box with Pilz Relay (Cat. No. 1000-NXSLSV85)  
Renewal Parts (Continued)**

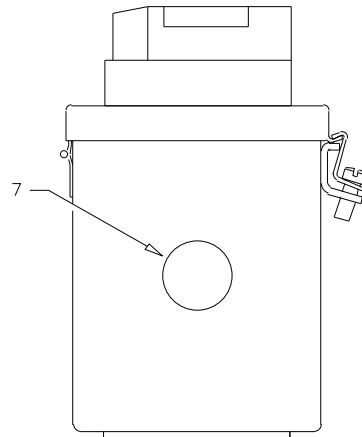
<b>Item</b>	<b>Description</b>	<b>Part Number</b>	<b>Amount</b>
8	Primary Fuses Kldr 0.75 A	25183-272-11	2
9	Secondary Fuse Block	1492-FB1C30-L	1
10	Secondary Fuse Kldr 0.75 A	25183-272-11	1
11	50 W Idec Power Supply	PS5R-D24	1
12	100S-85 A MCS Contactor	100S-C85D04C	1
12A	MCS Surge Suppressor	100-FSC280	1
12B	MCS Auxiliary 2 N.O.	100-SA20	1
13	Pilz Relay	PU3Z 24V	1
14	Timing Relay	700-FEA1SU22	1
15	Safety Relay	440R-ZBL220Z24	2
16	MCS Relay	700-CF220D	1
16A	Protective Cover	100-SCCA	1
16B	MCS Surge Suppressor	100-FSC280	1
17	Terminal Blocks	1492-H1	39
18	End Barrier	1492-N36	1
19	End Anchors	1492-N23	2
20	LED Terminal Blocks	1492-HM2V24	3
21	End Barrier	1492-NM40	3
22	Harting Insert Screw	09330102601	4
23	Harting Insert Screw	09330102701	4
24	Harting Hood	09300100422	4
25	Harting Base	09300100301	4
26	Sealcon	CD21AAGY	4
26A	Sealcon	CD29AAGY	1
27	Harting Male Insert Screw	09330242601	1
28	Harting Female Insert Screw	09330242701	1
29	Harting Hood	09300240421	1
30	Harting Base	09300240301	1
31	A-B Logo	40009-100-52	1
32	Wiring Diagram	Y-155798 Rev. M	1
33	User Manual	Pub. 1000-UM001A-US-P	1
34	LED Explanation Sheet	49000-082-01	1
35	Warning Label	32005-374-01	1

Figure A.3 Composite Assembly of a Bulletin 194E SLS Switch



COVER

BASE



SPECIAL INSTRUCTIONS

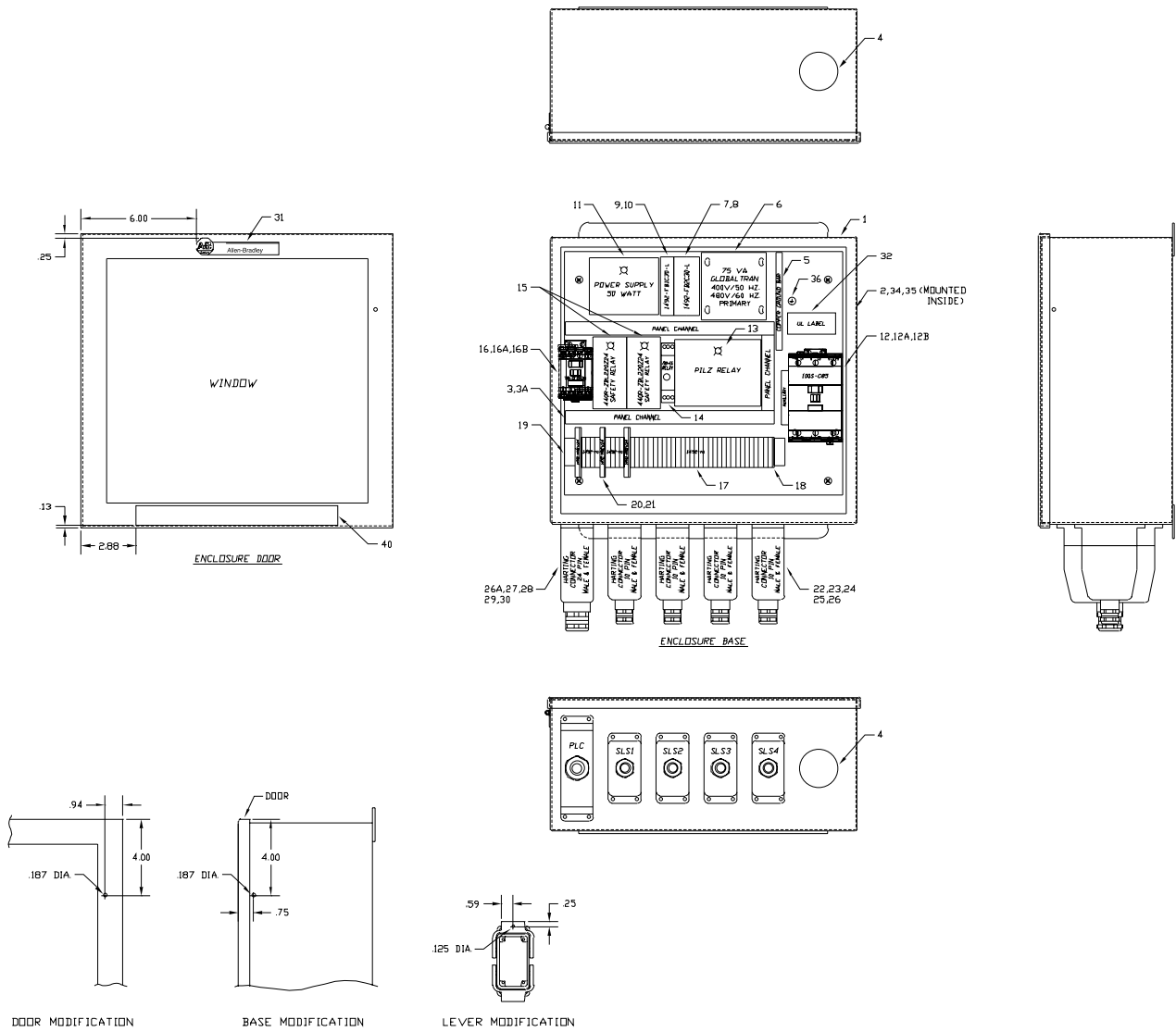
WIRE: #16 BLUE  
#16 GREEN/YELLOW-GROUND

NOTE-ADD .187 DIA. HOLE IN MTG. RAIL AND CORRESPONDING .136 DIA. #8-32 TAPPED HOLE IN STAND-OFF TO PREVENT TURNING.

**Table A.D Composite Assembly of a Bulletin 194E SLS Switch**

<b>Item</b>	<b>Description</b>	<b>Part Number</b>	<b>Amount</b>
1	Encl. w/Mtg. Plt. (Ref. 32267-132-51) (Ref. 32267-133-01)	Eng. Data	1
2	194R Operating Handle — Black	194R-HS4	1
3	Phenolic Nameplate	H-26553	1
3A	#4-40 x 0.187 Pan Hd. Stain. St. Screw	28010-068-01	2
4	800H Pilot Light	800H-QR24W	1
4A	800H Nameplate Engrv. SAFE	800H-W100E	1
5	194E 25 A Load Switch	194E-A25-1753	1
5A	194E Auxiliary Contact 1 N.O. - 1 N.C.	194E-A-P11	1
5B	194E Adapter Kit	194E-G3675	1
5C	Operating Shaft	31013-314-01	1
6	Terminal Block Stand-Off (See Note)	40164-416-01	1
6A	Terminal Block Mtg. Rail (See Note)	1492-DR3	1
6B	Terminal Blocks	1492-WM3	8
6C	Grounding Terminal Block	1492-WMG3	1
6D	End Barrier	42164-017-01	1
6E	Partition Plate	1492-PPM3	1
6F	End Anchor	1492-EA15	1
7	Cap Plug	28470-007-01	1
8	Nameplate Stamp w/Serial No.	H-25932	1
9	Trademark Plate	H-18742	1
10	Wiring Diagram	Y156328	1
11	Renewal Parts List	49000-064-01	1

**Figure A.4 Composite Assembly of a Bulletin 100, 85 A SLS Box with Pilz Relay (Cat. No. 1000-NXSLSV85)**



**Table A.E Composite Assembly of a Bulletin 100, 85 A SLS Box with Pilz Relay (Cat. No. 1000-NXSLSV85)**

Item	Description	Part Number	Amount
1	Encl. w/Mtg. Plt. (Ref. 32267-121-51) (Ref. 32267-122-02)	Eng. Data	1
2	Nameplate	49103-449-01	1
3	Panel Channel (Panduit E.5x2WH6)	Eng. Data	1
3A	Cover (Panduit C.5WH6)	Eng. Data	1
4	Heyco Bushing SB-200-26	Eng. Data	2
5	Ground Bus N70-12-1	Eng. Data	1
6	Micron Transformer B075-1017-GA	Eng. Data	1
7	Primary Fuse Block	1492-FB2C30-L	1

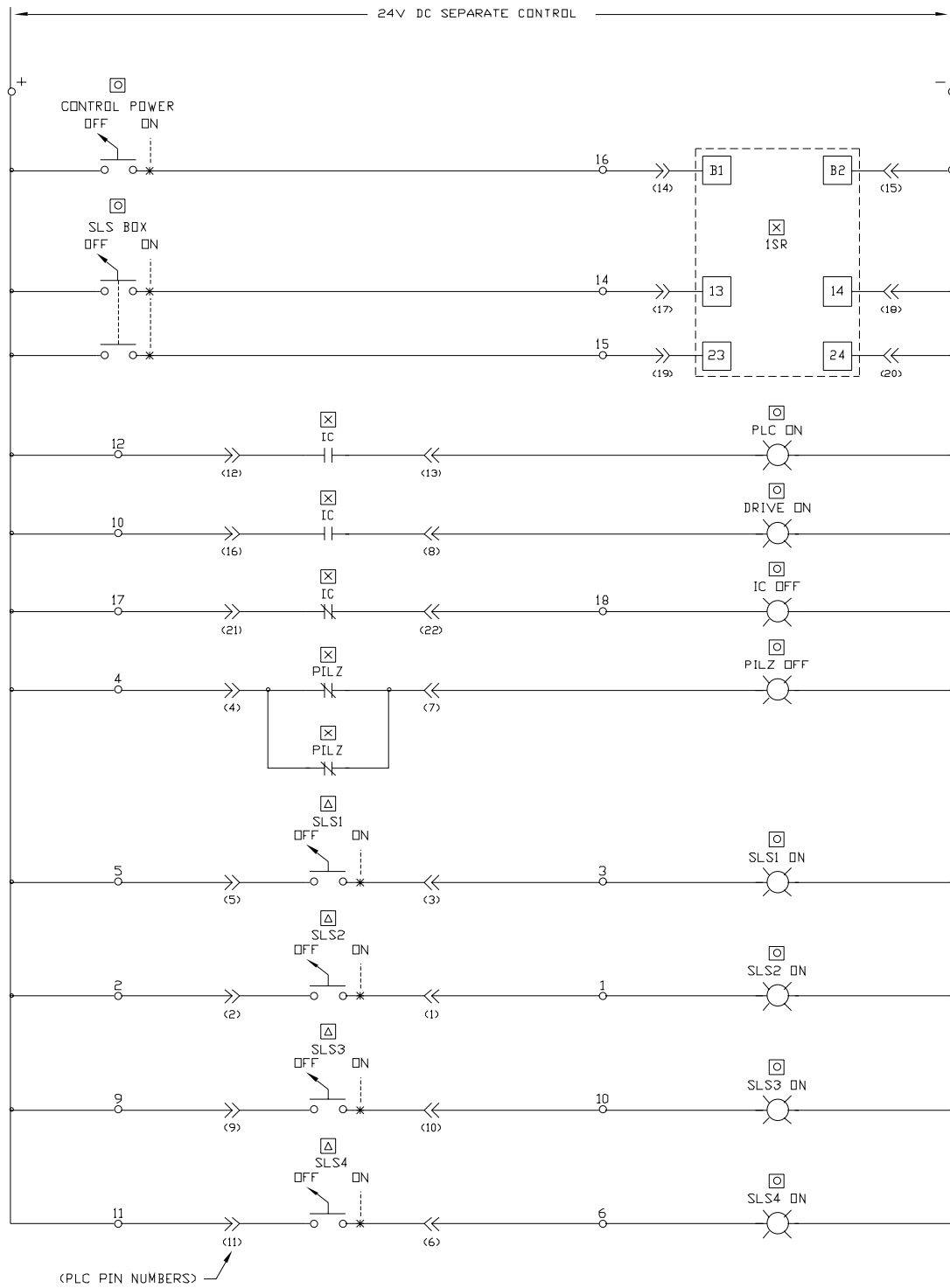
**Table A.E Composite Assembly of a Bulletin 100, 85 A SLS Box with Pilz Relay  
(Cat. No. 1000-NXSLSV85) (Continued)**

<b>Item</b>	<b>Description</b>	<b>Part Number</b>	<b>Amount</b>
8	Primary Fuses Kldr 0.75 A	25183-272-11	2
9	Secondary Fuse Block	1492-FB1C30-L	1
10	Secondary Fuse Kldr 0.75 A	25183-272-11	1
11	50 W Idec Power Supply PS5R-D24	Eng. Data	1
12	100S-85 A MCS Contactor	100S-C85D04C	1
12A	MCS Surge Suppressor	100-FSC280	1
12B	MCS Auxiliary 2 N.O.	100-SA20	1
13	Pilz Relay PU3Z	Eng. Data	1
14	Timing Relay	700-FEA1SU22	1
15	Safety Relay	440R-ZBL220Z24	2
16	MCS Relay	700-CF220D	1
16A	Protective Cover	100-SCCA	1
16B	MCS Surge Suppressor	100-FSC280	1
17	Terminal Blocks	1492-H1	39
18	End Barrier	1492-N36	1
19	End Anchors	1492-N23	2
20	LED Terminal Blocks	1492-HM2V24	3
21	End Barrier	1492-NM40	3
22	Harting Insert Screw #09330102601	Eng. Data	4
23	Harting Insert Screw #09330102701	Eng. Data	4
24	Harting Hood #09300100422	Eng. Data	4
25	Harting Base #09300100301	Eng. Data	4
26	Sealcon #CD21AAGY	Eng. Data	4
26A	Sealcon #CD29AAGY	Eng. Data	1
27	Harting Male Insert Screw #09330242601	Eng. Data	1
28	Harting Female Insert Screw #09330242701	Eng. Data	1
29	Harting Hood #09300240421	Eng. Data	1
30	Harting Base #09300240301	Eng. Data	1
31	A-B Logo	40009-100-52	1
32	UL Label	40006-315-01	1
33	Wiring Diagram	Y-155798	1
34	CE Mark	44006-076-05	1
35	Category 4 per IEC 954 Label (Ref. 32005-371-01)	Get from Eng.	1
36	Ground Symbol Label	Make at Assembly	1
37	Renewal Parts List	49000-063-01	1
38	User Manual	Pub. 1000-UM001A-US-P	1
39	LED Explanation Sheet	49000-082-01	1
40	Warning Label (Ref. 32005-374-01)	Get from Eng.	1



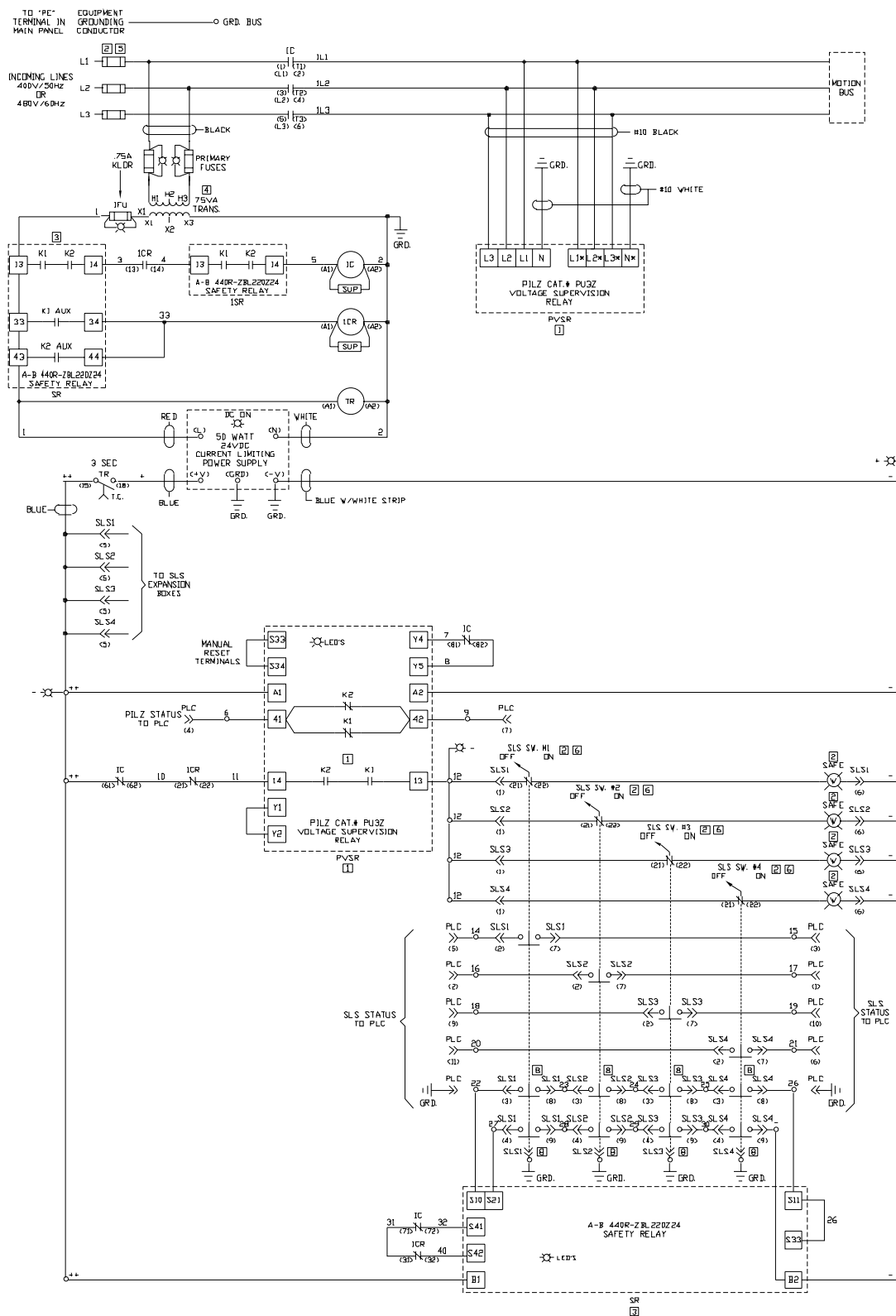


**Figure A.6 Test Panel Schematic**

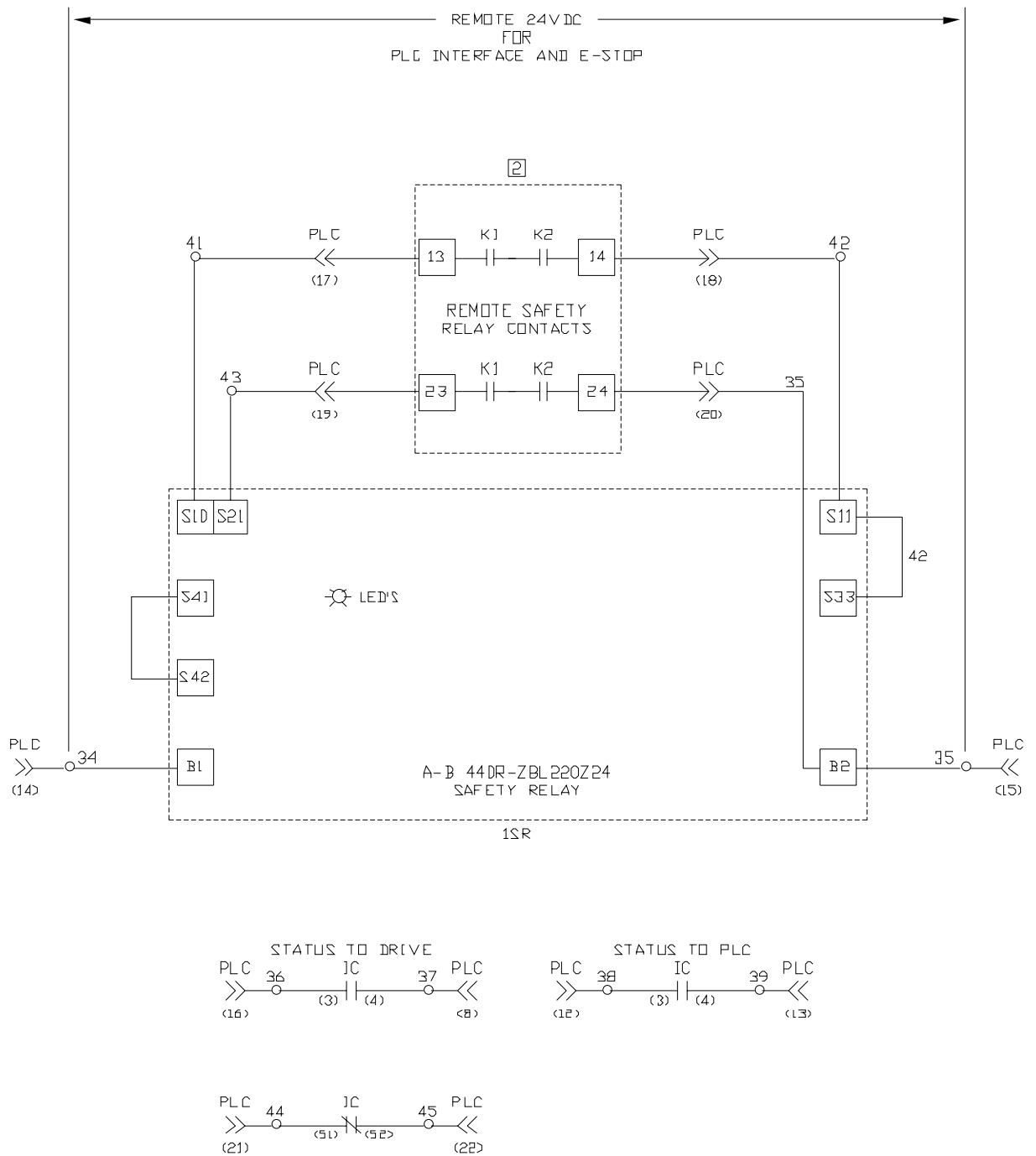


- LEGEND**
- ☒ = IN SLS BOX
  - ☐ = IN TEST PANEL
  - ⬠ = SLS SWITCH

Figure A.7 Safety Lockout System Box Schematic

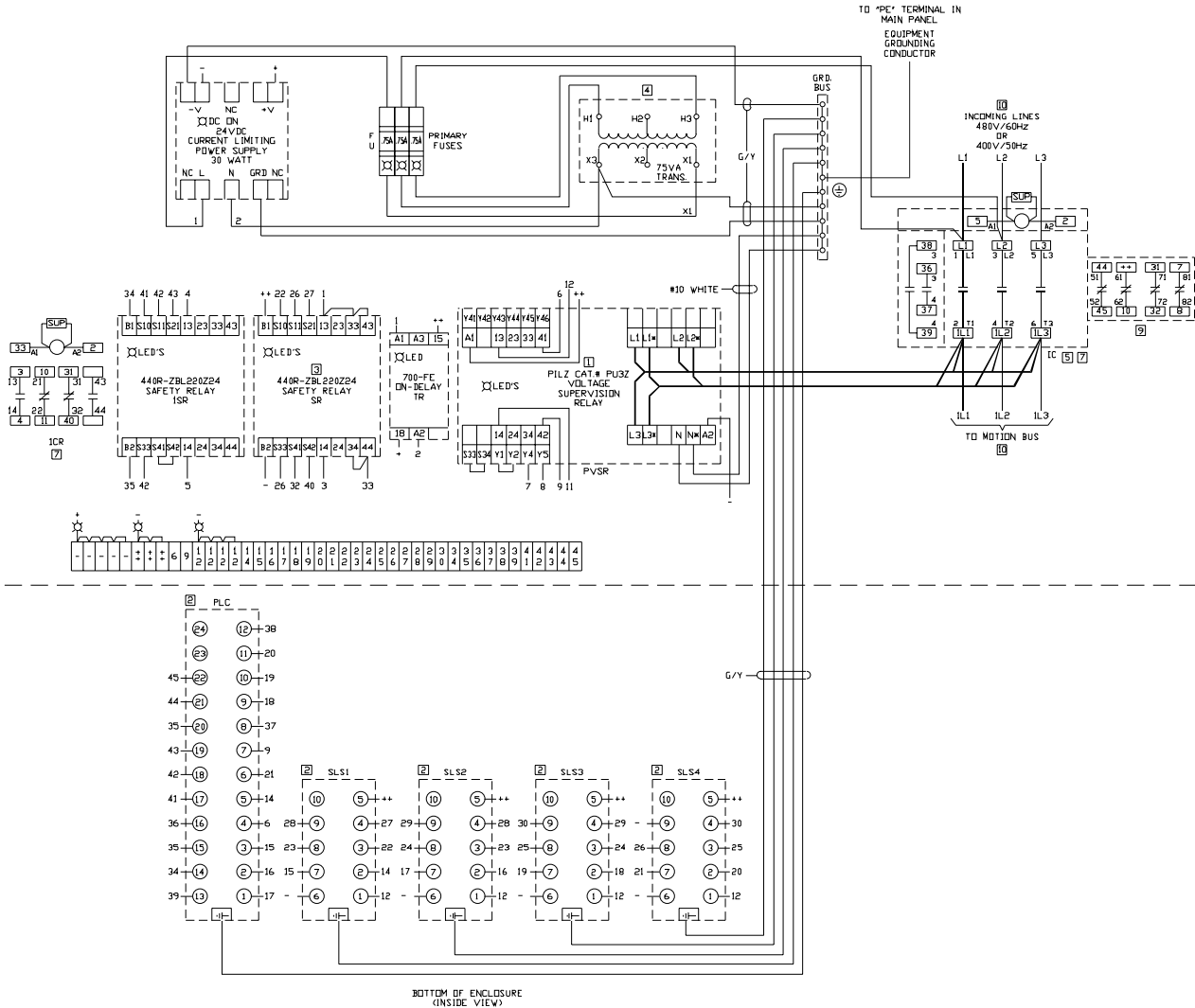


**Figure A.8 Safety Lockout System Box Schematic, Continued**



Continued on next page

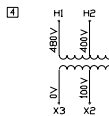
Figure A.9 Safety Lockout System Box Connection Diagram



**NOTES**

1) WITH CONTROL POWER ON, OUTPUT IS OPEN IF MEASURED VOLTAGE IS GREATER THAN 10VAC AND Y4-Y5 IS OPEN. CLOSED IF MEASURED VOLTAGE IS LESS THAN 10VAC AND Y4-Y5 IS CLOSED.

2) REMOTE DEVICE  
THIS SAFETY RELAY CHECKS FOR OPERATION OF THE SLS SWITCH AND CHECKS SLS CABLE FOR A FAILURE. THE OUTPUT CONTACTS ARE REDUNDANT AND SELF-MONITORING. THEY WILL PREVENT THE ISOLATION CONTACTOR FROM ENERGIZING IN THE EVENT OF A FAILURE IN THE SLS SWITCH CIRCUITS OR THE SLS SWITCH.



5) THIS PANEL SHALL BE PROTECTED BY A TIME DELAY CLASS "J" FUSE. 85 AMP ISOLATION CONTACTOR SIZE = 100 AMP MAX. 30 AMP ISOLATION CONTACTOR SIZE = 40 AMP MAX. MAX. AVAILABLE FAULT CURRENT = 40KA @ 480V. DISCONNECTING MEANS PROVIDED BY OTHERS AND IS LOCATED INSIDE THE MAIN CONTROL PANEL WHERE THE SLS PANEL IS ALSO LOCATED.

6) SLS SWITCH CABLE SPECIFICATIONS:  
1) WHEN INSTALLED, CABLE MUST BE PROTECTED FROM PHYSICAL DAMAGE. THIS MAY REQUIRE CONDUIT.  
2) MUST HAVE A SHIELD WITH DRAIN WIRE.  
3) 600 VOLT INSULATION RECOMMENDED.  
4) COPPER CONDUCTORS.  
5) MAXIMUM SLS SWITCH CIRCUIT LENGTH BETWEEN SLS SW AND SLS BOX. OUT AND BACK 4 TIMES \* MAX WIRE LENGTH DIVIDED BY 8.  
(TOTAL LENGTH OF WIRES)  
#14 AWG = 4600 FT = 11.5A  
#16 AWG = 2600 FT = 11.5A  
#18 AWG = 1300 FT = 11.5A  
6) COLOR CODING FOR INDIVIDUAL CONDUCTORS.  
7) POSSIBLE SOURCE AND TYPE-ALPHA WIRE \*XTRA-GUARD 2" PART #25450/9 FOR #14 AWG 64" O.D. #25440/9 FOR #16 AWG 61" O.D. #25430/9 FOR #18 AWG 55" O.D. FOR SLS SWITCHES.  
8) SLS SWITCH CABLE SHOULD NOT BE RUN IN A LINE VOLTAGE WIREWAY.

7) IC AND ICR HAVE POSITIVELY GUIDED (DIRECT DRIVE) CONTACTS.

8) SLS SWITCH CONTACT WIRED BETWEEN TERMINALS S21 AND S22 ON THE SAFETY RELAY MUST CLOSE BEFORE OR AT THE SAME TIME AS THE SLS SWITCH CONTACT WIRED BETWEEN TERMINALS S10 AND S11 ON THE SAFETY RELAY.  
SEE T-156328 FOR SLS SWITCH WIRING DIAGRAM.

9) TOP MOUNTED 100-FA04 AUXILIARY CONTACT IS NOT REMOVABLE.

10) USE COPPER WIRE ONLY. SELECT FOR 75°C. 85 AMP TORQUE LINE AND LOAD 5/16-in MAX WITH 5/32-in Allen WRENCH. 30 AMP TORQUE LINE AND LOAD 3/16-in MAX.

11) PANEL TO BE SERVICED, CERTIFIED AND SEALED FOR USE BY SAFETY LOCKOUT SYSTEM TECHNICIAN ONLY.

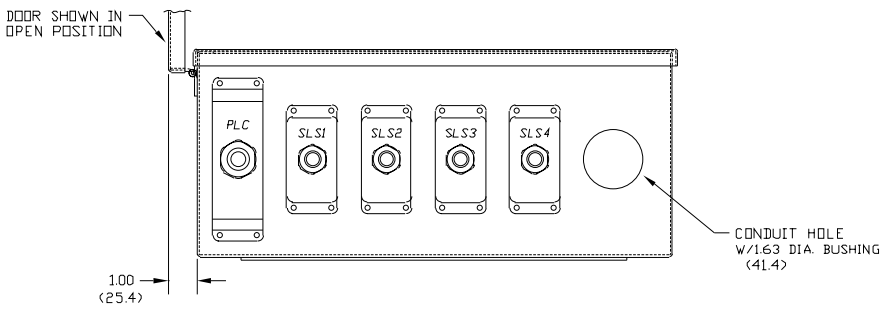
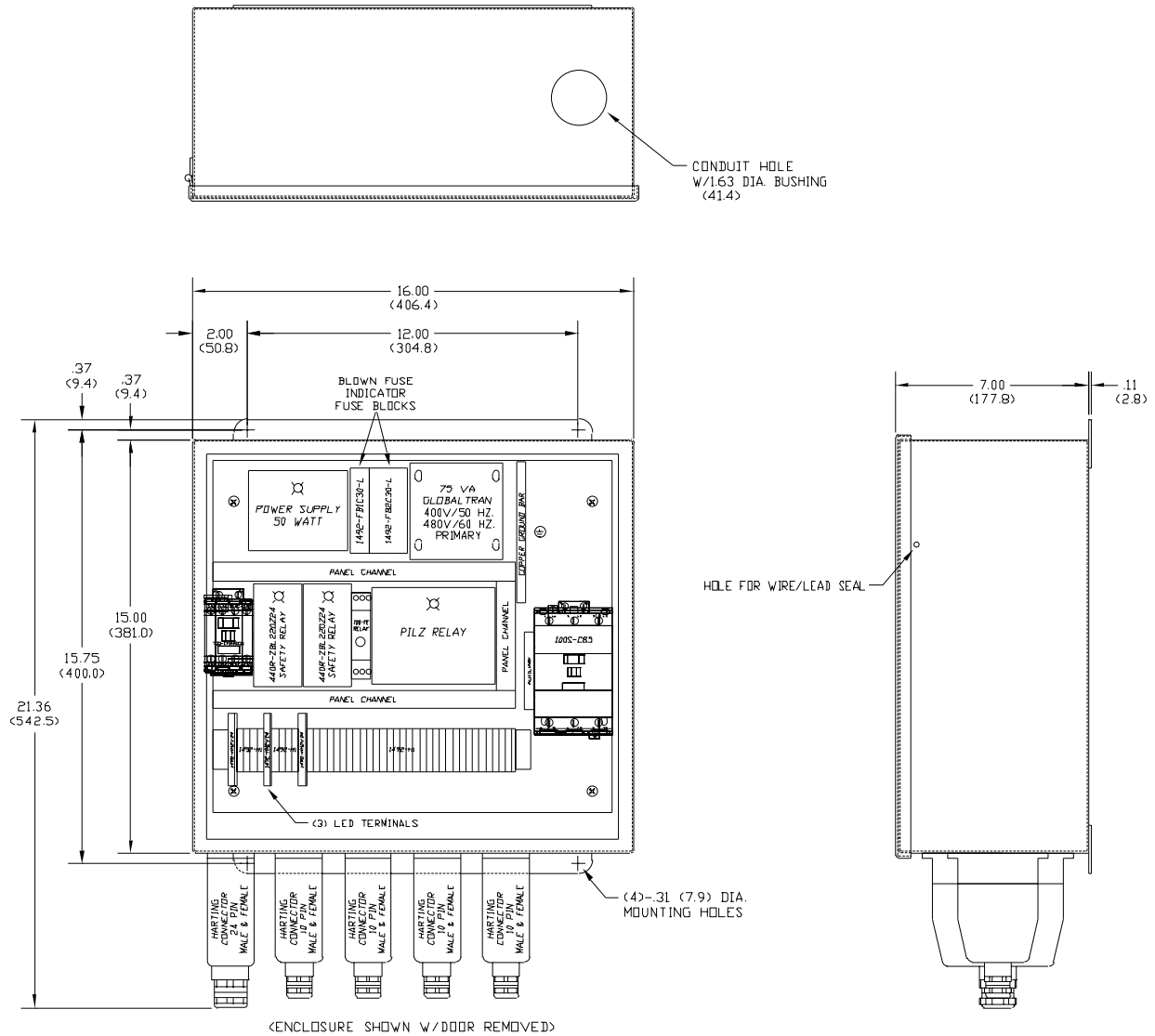
12) THIS PANEL CONSIDERED AN 'OPEN TYPE'. IT MUST BE HOUSED IN AN ADDITIONAL AND SUITABLE ENCLOSURE.

13) NOTE: THIS PANEL HAS AN EXTERNAL VOLTAGE OF MORE THAN ONE SOURCE.

14) THE GROUND TERMINAL (GRD, N OR N\*) OF EACH COMPONENT MUST BE CONNECTED DIRECTLY TO THE GRD. BUS WITH THE PROPERLY SIZED GREEN/YELLOW DR WHITE WIRE. DAISY CHAINING IS NOT PERMITTED.

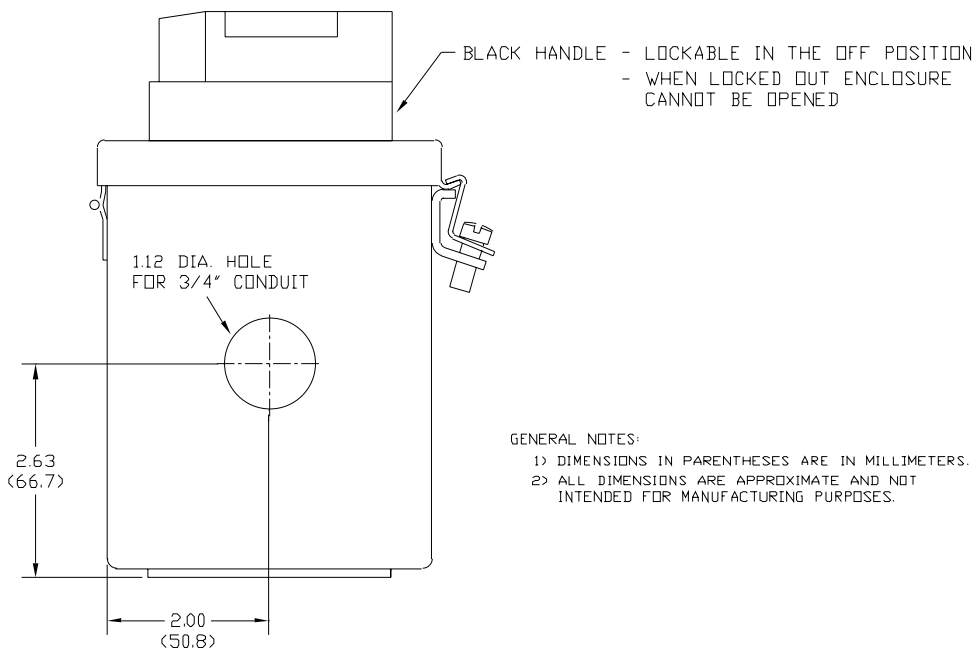
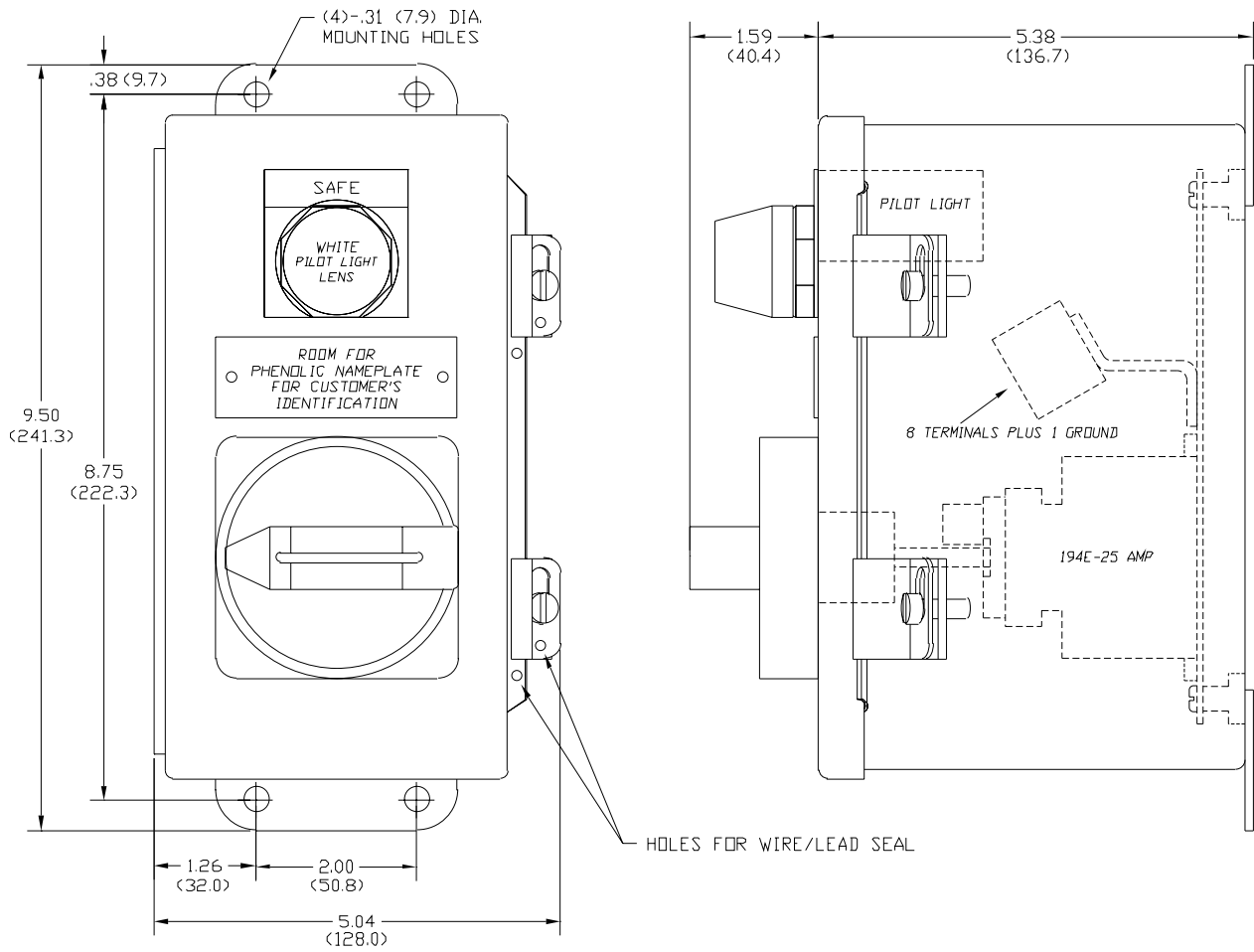
15) THIS SLS PANEL IS CONFIGURED FOR 4 SLS SWITCHES. THE NUMBER OF SLS SWITCHES MAY BE INCREASED BY THE USE OF SLS EXPANSION BOXES. SEE Y-156779 FOR 4 AND Y-157131 FOR 10 ADDITIONAL SWITCHES AND INSTRUCTIONS. 22 SLS SWITCHES MAXIMUM TOTAL.

Figure A.10 SLS Box with Pilz Relay, 30 A (Cat. No. 1000-NXSLSV30) and 85 A (Cat. No. 1000-NXSLSV85) Dimension Drawing



- GENERAL NOTES:
- 1) DIMENSIONS IN PARENTHESES ARE IN MILLIMETERS.
  - 2) ALL DIMENSIONS ARE APPROXIMATE AND NOT INTENDED FOR MANUFACTURING PURPOSES.

Figure A.11 SLS Switch, NEMA Type 4 Stainless Dimension Drawing



GENERAL NOTES:  
 1) DIMENSIONS IN PARENTHESES ARE IN MILLIMETERS.  
 2) ALL DIMENSIONS ARE APPROXIMATE AND NOT INTENDED FOR MANUFACTURING PURPOSES.

**Figure A.12 Safety Lockout System Switch Connection Diagram**

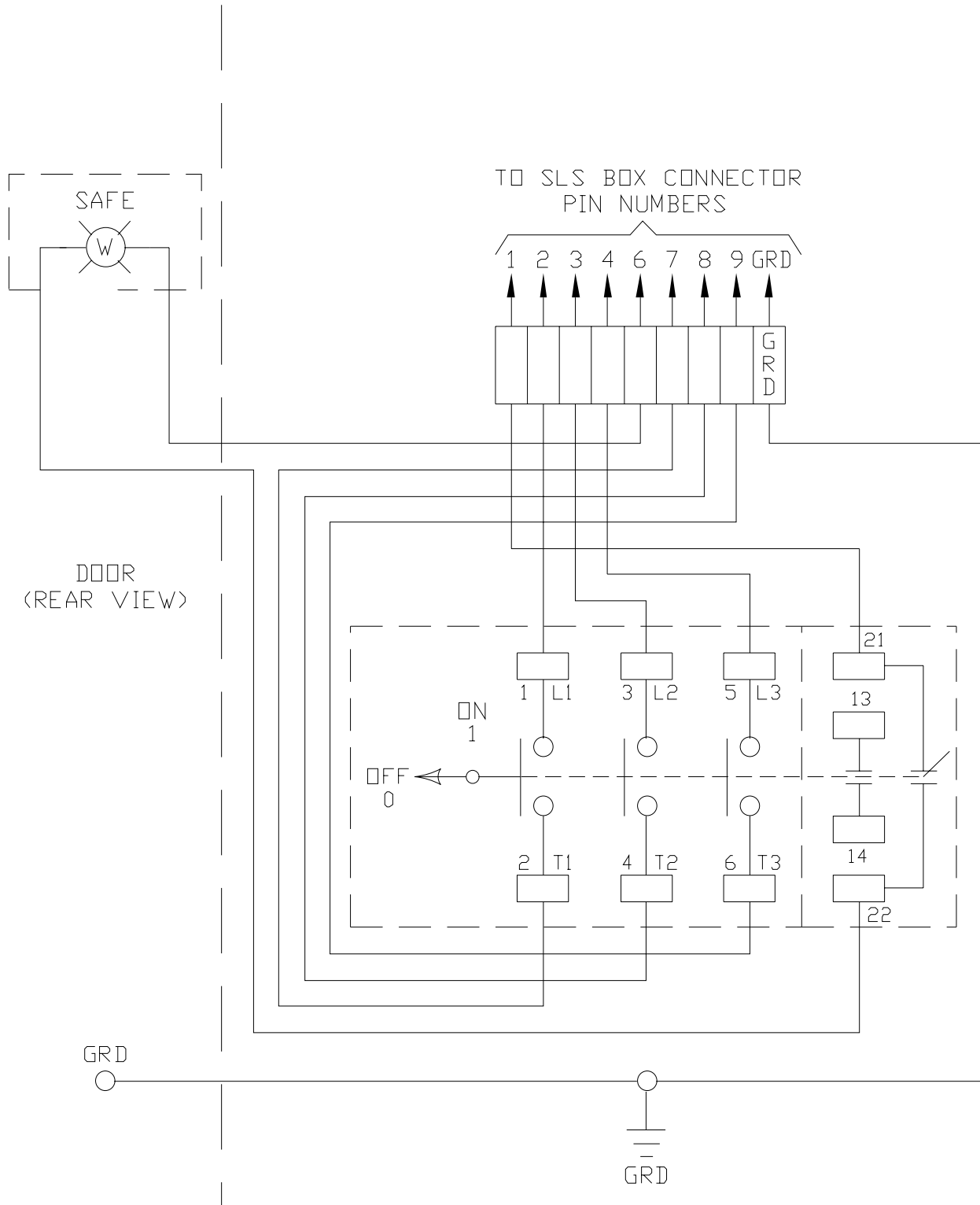
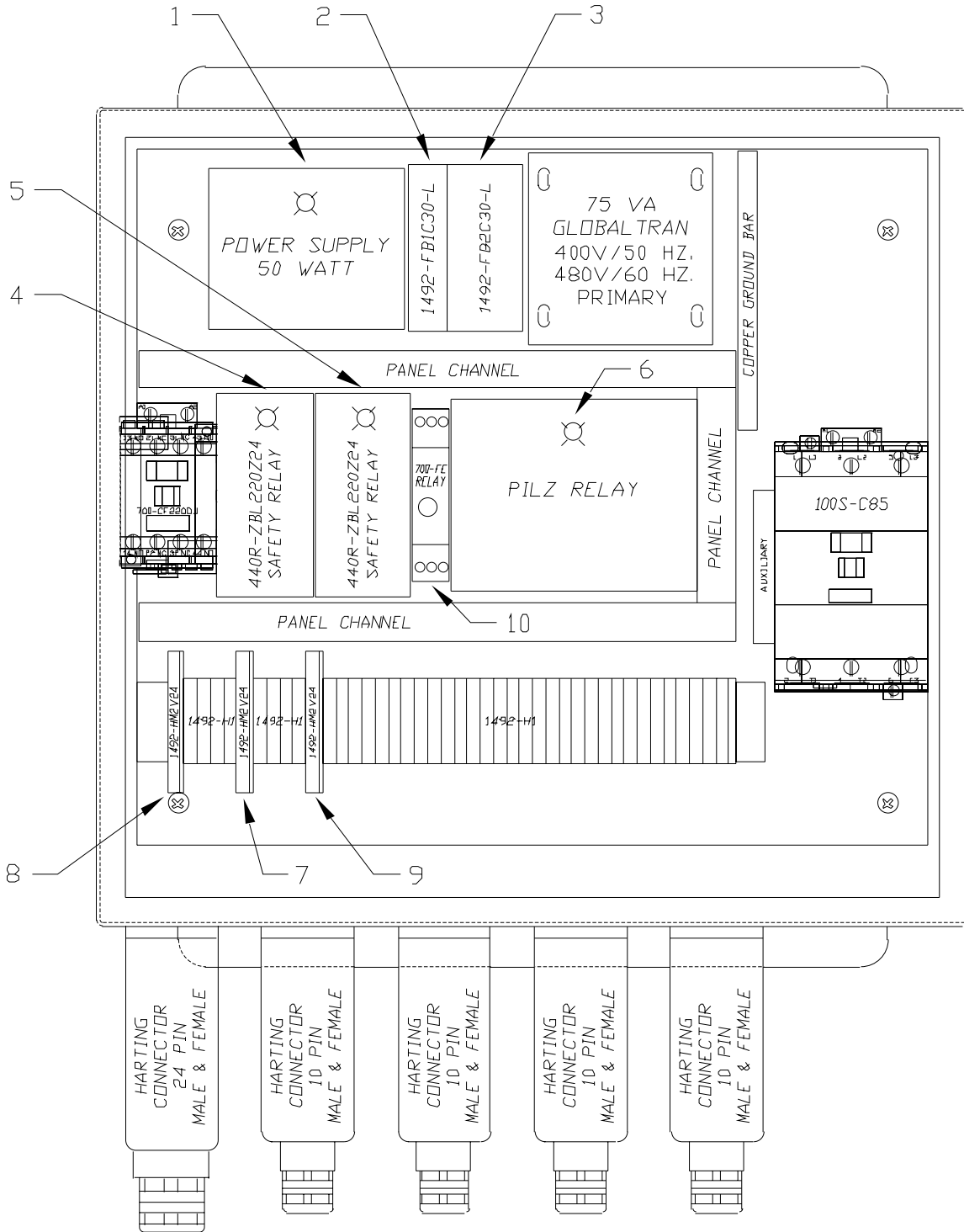


Figure A.13 LED Explanation



ENCLOSURE SHOWN W/DOOR REMOVED



**Table A.F LED Explanation**

Item	Description	Indicator	Explanation
1	Power Supply	LED	DC on when 120V is applied
2	Control Transformer Sec. Fuse	Blown Fuse	On when fuse is blown
3	Control Transformer (2) Pri. Fuses	Blown Fuse	On when fuse is blown
4	Safety Relay 1SR	LED	<ul style="list-style-type: none"> <li>• POWER on when 24V DC is applied</li> <li>• CH1 on when circuit S10 to S11 is closed</li> <li>• CH2 on when circuit S21 to B2 is closed</li> <li>• K1 on when internal relay K1 is energized</li> <li>• K2 on when internal relay K2 is energized</li> </ul>
5	Safety Relay SR	LED	<ul style="list-style-type: none"> <li>• POWER on when 24V DC is applied</li> <li>• CH1 on when circuit S10 to S11 is closed because all SLS switches are in the ON position</li> <li>• CH2 on when circuit S10 to S11 is closed because all SLS switches are in the ON position</li> <li>• K1 on when internal relay K1 is energized</li> <li>• K2 on when internal relay K2 is energized</li> </ul>
6	Pilz Relay PVSR	LED	<ul style="list-style-type: none"> <li>• POWER on when 24V DC is applied</li> <li>• VL1-L2 on voltage L1 to L2 is above 10V</li> <li>• VL2-L3 on voltage L2 to L3 is above 10V</li> <li>• VL1-L3 on voltage L1 to L3 is above 10V</li> <li>• VL1-N on voltage L1 to ground is above 10V</li> <li>• VL2-N on voltage L2 to ground is above 10V</li> <li>• VL3-N on voltage L3 to ground is above 10V</li> <li>• SYSTEM FAILURE on when one of the eight voltage sensing connections is open or there is an internal fault in the PU3Z</li> <li>• VOLTAGE HAZARD on when measured voltage is greater than 10V</li> </ul>
7	++ Terminal Block	LED	On when the timer contact is closed
8	- Terminal Block	LED	On when the 24V DC power supply output is on
9	12 Terminal Block	LED	On when IC and 1CR are off, PVSR output is closed, and an SLS switch is off
10	Timing Relay TR	LED	On when time delay is complete and output N.O. contact is closed

**Notes:**

## References

**A.** NFPA 70E 1995 edition, NFPA 79 1997 edition

**B.** IEC 947, 60204-1, 954-1

**Notes:**

**Notes:**

**Notes:**



---

**Reach us now at [www.rockwellautomation.com](http://www.rockwellautomation.com)**

Wherever you need us, Rockwell Automation brings together leading brands in industrial automation including Allen-Bradley controls, Reliance Electric power transmission products, Dodge mechanical power transmission components, and Rockwell Software. Rockwell Automation's unique, flexible approach to helping customers achieve a competitive advantage is supported by thousands of authorized partners, distributors and system integrators around the world.

**Americas Headquarters**, 1201 South Second Street, Milwaukee, WI 53204, USA, Tel: (1) 414 382-2000, Fax: (1) 414 382-4444  
**European Headquarters SA/NV**, avenue Herrmann Debroux, 46, 1160 Brussels, Belgium, Tel: (32) 2 663 06 00, Fax: (32) 2 663 06 40  
**Asia Pacific Headquarters**, 27/F Citicorp Centre, 18 Whitfield Road, Causeway Bay, Hong Kong, Tel: (852) 2887 4788, Fax: (852) 2508 1846

Publication 1000-UM001B-US-P - July 2000

