

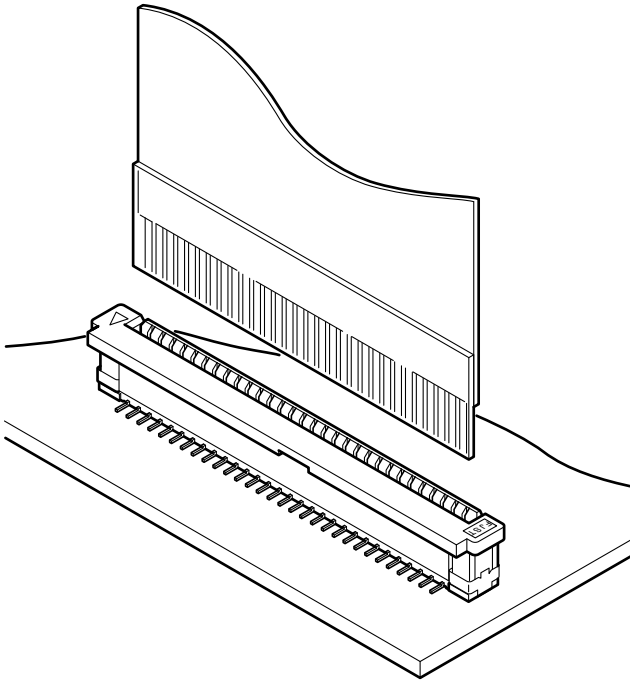

FAZ CONNECTOR

1.0 mm pitch/Connectors for PC board/For FFC • ZIF Type



The FAZ connector is SMT type for PC board connector, which is a Zero Insertion Force (ZIF) type for FFC connection with a lead pitch of 1.0 mm.

■ Features

● Secure connection with ZIF type

ZIF type is adopted due to improving the wear resistance and the mating life of the connector. After temporarily inserting the FFC into the connector with low insertion force, the FFC can be connected and locked securely by operating the slider.

● SMT (Surface mount technology) type

The SMT type provides easy high-density mounting on the board and enables reflow soldering. Secure the fixing reliability to the board with the solder tab.

● Embossed taping for automatic mounting

This connector is supplied in embossed tape packaging, for mounting by automatic placement machines.

■ Standards

Ⓜ: Recognized E60389

Ⓢ: Certified LR 20812

■ Specifications

- Current rating: 1.0 A AC/DC
- Voltage rating: 50 V AC/DC
- Temperature range: -25°C to +85°C
(including temperature rise in applying electrical current)
- Contact resistance: Initial value/ 20 mΩ max.
After environmental tests/ 40 mΩ max.
- Insulation resistance: 500 MΩ min.
- Withstanding voltage: 500 VAC/minute
- Applicable FFC: Conductor pitch/ 1.0 mm
Conductor width/ 0.7 mm
Mating part thickness/ 0.3 ± 0.05 mm

* In using the products, refer to "Handling Precautions for Terminals and Connectors" described on our website (Technical documents of Product information page).

* RoHS2 compliance

* Dimensional unit: mm

* Contact JST for details.

FAZ CONNECTOR

Connector

Top entry type

< Single-row, Normal type > ●With bosses

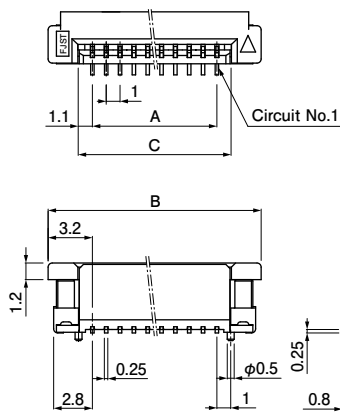

< Single-row, Normal type > ●Without bosses

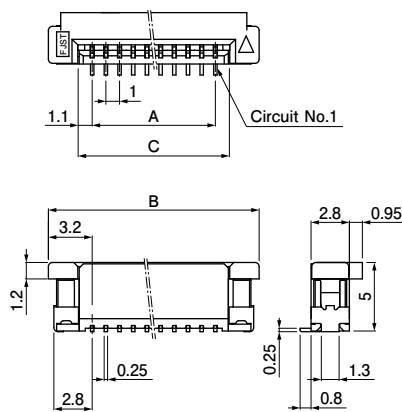

< Single-row, Reverse type > ●Without bosses

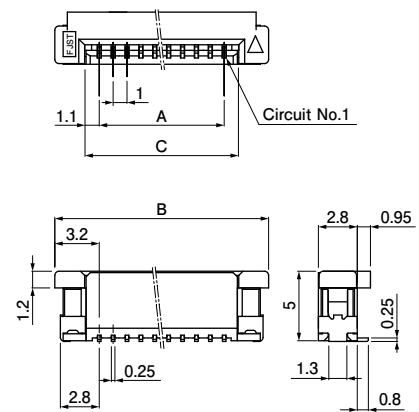

< Staggered, Normal type, Normal suction surface type >

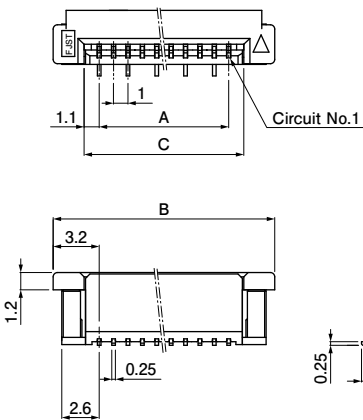

< Staggered, Normal type, Expanded suction surface type > ●With solder tab

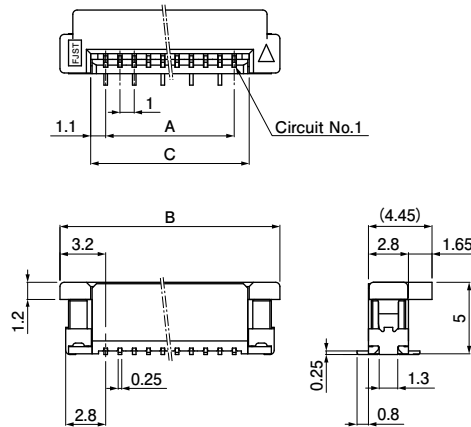

Top entry type

No. of circuits	Model No.					Dimensions (mm)			Q'ty/reel
	Single-row			Staggered, Normal type		A	B	C	
	Normal type		Reverse type	Normal suction surface type	Expanded suction surface type				
	With bosses	Without bosses	Without bosses		With solder tab				
9	—	—	—	T09FAZ-SMT-TF	—	8.0	14.4	10.2	1,000
20	—	—	—	T20FAZ-SMT-TF	—	19.0	25.4	21.2	1,000
22	—	—	—	T22FAZ-SMT-TF	T22FAZ-SMT-F-TF	21.0	27.4	23.2	1,000
24	—	—	—	T24FAZ-SMT-TF	—	23.0	29.4	25.2	1,000
26	T26FAZ-SM-1-TB	T26FAZ-SM-TB	T26FAZ-RSM-TF	T26FAZ-SMT-TF	—	25.0	31.4	27.2	1,000

Material and Finish

Contact: Copper alloy, copper-undercoated, tin-plated (reflow treatment)
Housing: Modified PA 6T, UL94V-0, ivory (natural)
Slider housing: PPS, UL94V-0, brown (natural)
Solder tab: Copper alloy, copper-undercoated, tin-plated (reflow treatment)

RoHS2 compliance This product displays (LF)(SN) on a label.
Note: The products listed above are supplied on embossed tape.

Connector

Side entry type

< Single-row, Normal type >

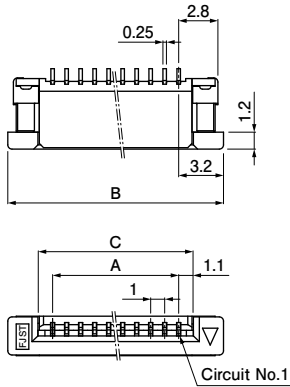

< Single-row, Reverse type >

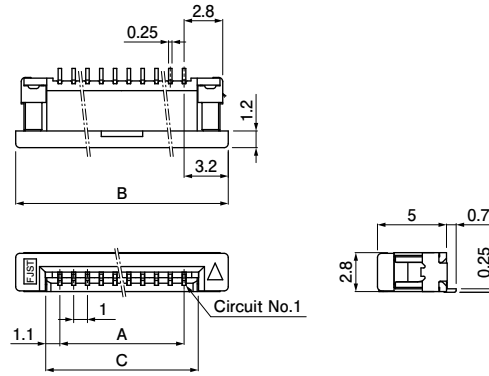

Side entry type

No. of circuits	Model No.		Dimensions (mm)			Q'ty/reel
	Single-row, Normal type	Single-row, Reverse type	A	B	C	
8	S08FAZ-SM-TB	—	7.0	13.4	9.2	2,000
9	S09FAZ-SM-TB	—	8.0	14.4	10.2	2,000
11	S11FAZ-SM-TB	—	10.0	16.4	12.2	2,000
16	S16FAZ-SM-TB	S16FAZ-RSM-TB	15.0	21.4	17.2	2,000
20	S20FAZ-SM-TB	S20FAZ-RSM-TB	19.0	25.4	21.2	2,000
25	S25FAZ-SM-TB	—	24.0	30.4	26.2	2,000
26	S26FAZ-SM-TB	S26FAZ-RSM-TB	25.0	31.4	27.2	2,000

Material and Finish

Contact: Copper alloy, copper-undercoated, tin-plated (reflow treatment)
Housing: Modified PA 6T, UL94V-0, ivory (natural)
Slider housing: PPS, UL94V-0, brown (natural)
Solder tab: Copper alloy, copper-undercoated, tin-plated (reflow treatment)

RoHS2 compliance This product displays (LF)(SN) on a label.
Note: The products listed above are supplied on embossed tape.

Lead section dimensions of FFC

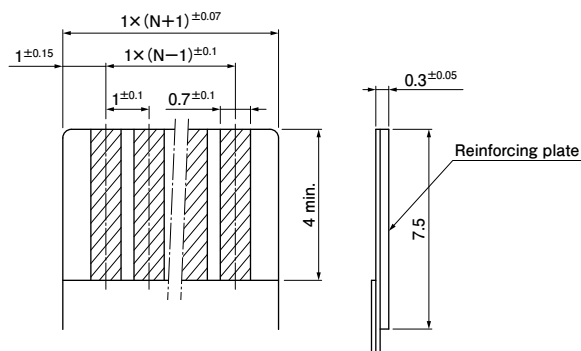

N: Number of circuits

FAZ CONNECTOR

PC board layout and Assembly layout

Top entry type

< Single-row, Normal type >

●With bosses

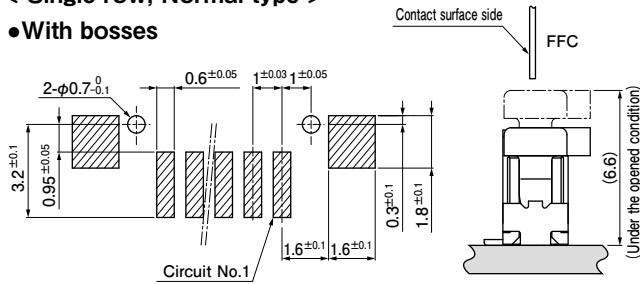

< Single-row, Normal type >

●Without bosses

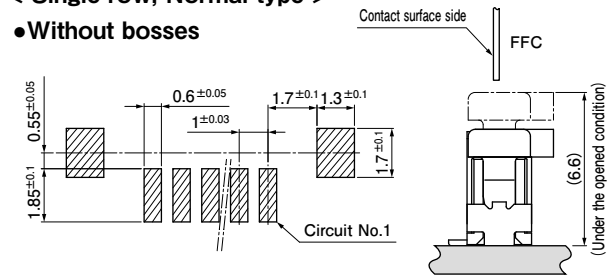

< Single-row, Reverse type >

●Without bosses

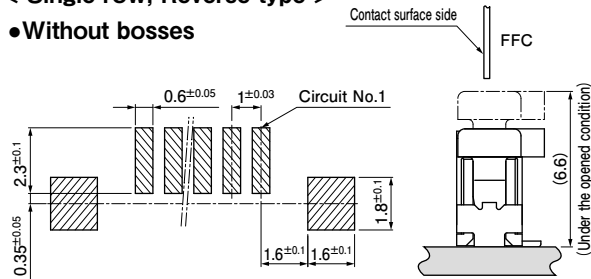

< Staggered, Normal type, Normal suction surface type >

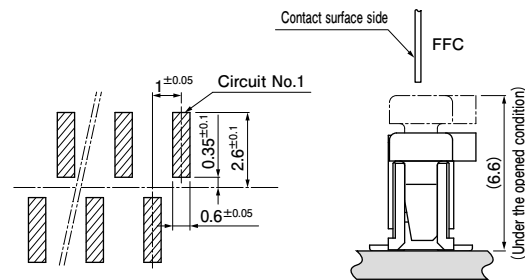

< Staggered, Normal type, Expanded suction surface type >

●With solder tab

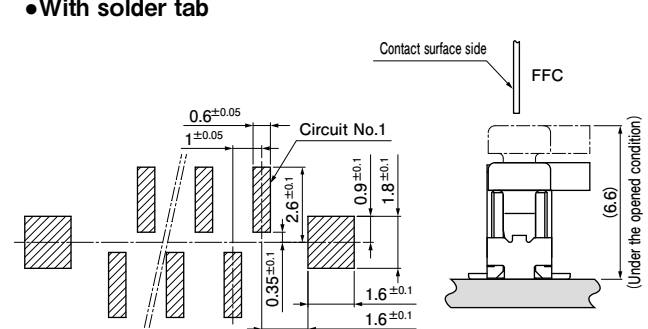

Side entry type

< Single-row, Normal type >

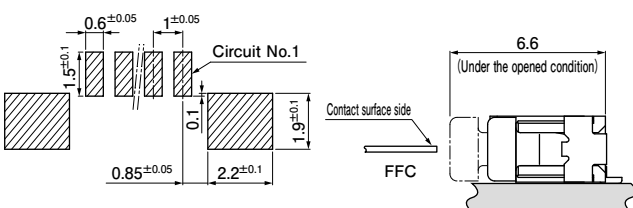

< Single-row, Reverse type >

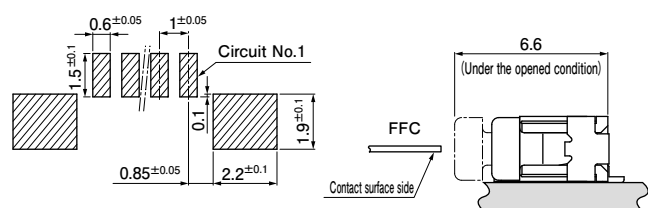

Note: 1. The above figure is the figure viewed from the connector mounting side.

2. Tolerances of pattern pitch on the PC board shall be ± 0.03 mm for top entry single row type and ± 0.05 mm for the top entry staggered type and side entry type and not be acumulative over the entire area.

3. Please contact JST for details as the dimensions shown in the above figure are reference values.