

Catalog Numbers

| Catalog No. | Amperage Rating | Max. Interrupting Rating |
|-------------------------------------|-----------------|--------------------------|
| 3 PHASE, 4 WIRE, 240V AC MAX | | |
| WBM31200B | 1200 | 65,000 |
| WBM31200BU | 1200 | 100,000 |

- TYPE 3R OUTDOOR ENCLOSURE
- MAIN BUS RATING: 1200A MAX., 240V AC Max.
- 3 PHASE
- FOR UNDERGROUND SERVICE ONLY
- ELECTRONIC BREAKER WITH MAINTENANCE MODE DAS®

Additional Modules



IMPORTANT - for use with:

| Module Description | Siemens Series# |
|--------------------|--|
| Main Breakers | WB(M), WEB(M), WXB, BFT |
| Switches | WMP, WS, WES, WXS |
| Tap/Terminal Boxes | WTB, WET, WT, PU, WTBN, WBT |
| Pull Boxes | WMMB |
| Meter Module | (W)MM, (W)MT, (W)ML, (W)MK, (W)MLZ(F), (W)MN |
| Meter Combinations | WC, WCL, WCT, |
| Extension Box | WSP, WSPD |
| Bussed Elbow | BE, WELB |

| Connect Modules Using: | Catalog Number / Torque |
|------------------------|---|
| QuickConnect | QC4, Torque 400-440 lb-in (35-36 ft.-lb.) |

Schematic

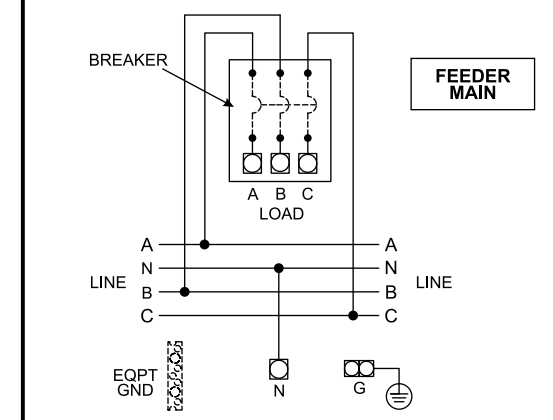
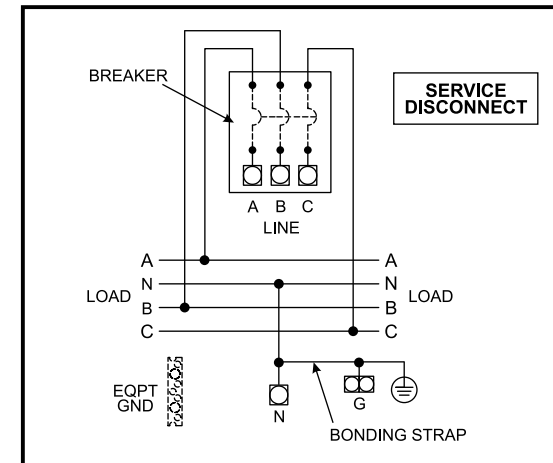

Terminals A, B, C and N:
Wire size (4) #2-500 kcmil CU/AL.
Torque terminals to 375 lb.in.
Ground terminal G:
Wire size #4-300 kcmil. Torque terminal to 250 lb.-in.

Accessories

| Equip Ground Acc'y Cat. No. ECLX069M | |
|--------------------------------------|------------------------|
| Small Terminals | Large Terminals |
| Wire Range / Torque | Wire Range / Torque |
| 10-14 AWG 20 lb-in | 10-14 AWG 35 lb-in |
| 8 AWG 25 lb-in | 8 AWG 40 lb-in |
| 6 AWG 35 lb-in | 1/0-6 AWG . 45 lb-in |

| | |
|---|---|
| Ground Bar Kit | ECLX069M |
| Ground Lug Kit (3 Position) | ECGLK3300, (3) #6-300kcmil, Torque 250 lb-in |
| Ground Lug Kit (6 Position) | ECGLK6300, (6) #6-300kcmil, Torque 250 lb-in |
| Breaker Lug Kit (factory installed) | LK34500 (kit includes 4 lugs) |
| Alternate Breaker Lug Kit | LK33750 - (3) 500-750 kcmil, Torque 375 lb.-in. (kit includes 4 lugs) |

FRONT VIEW SHOWN WITH COVER AND SHIELDS REMOVED

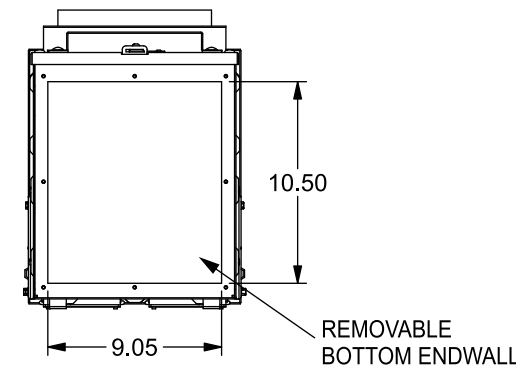
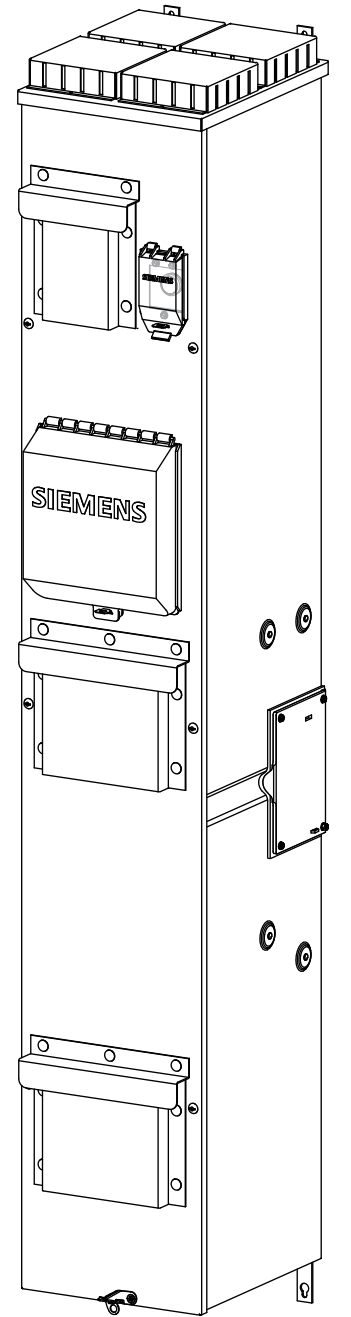
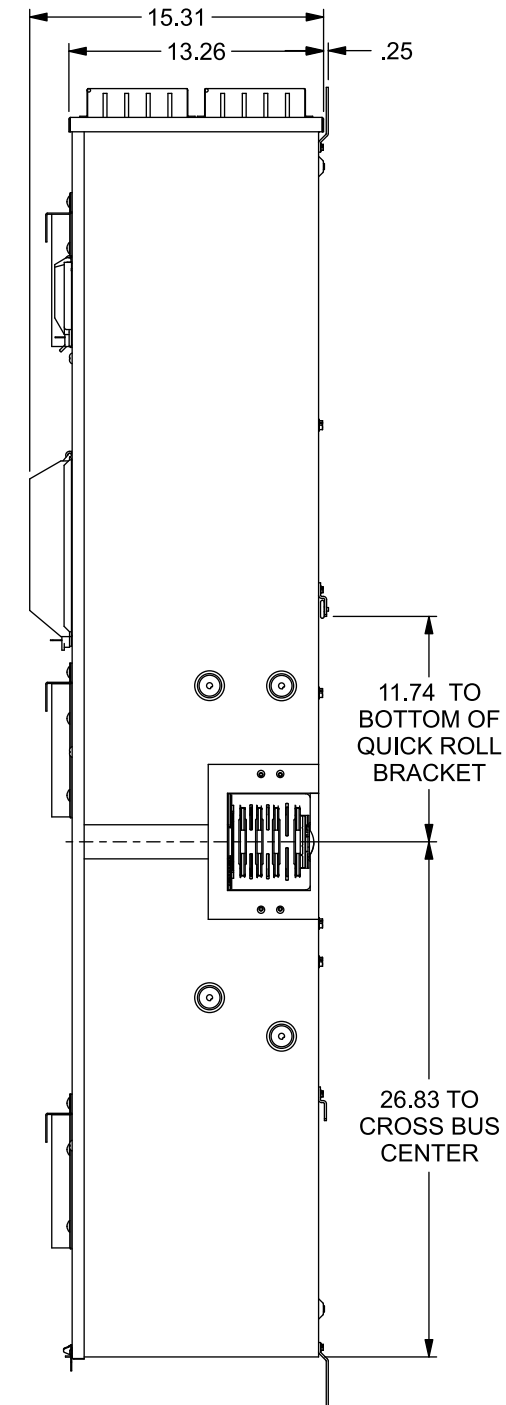
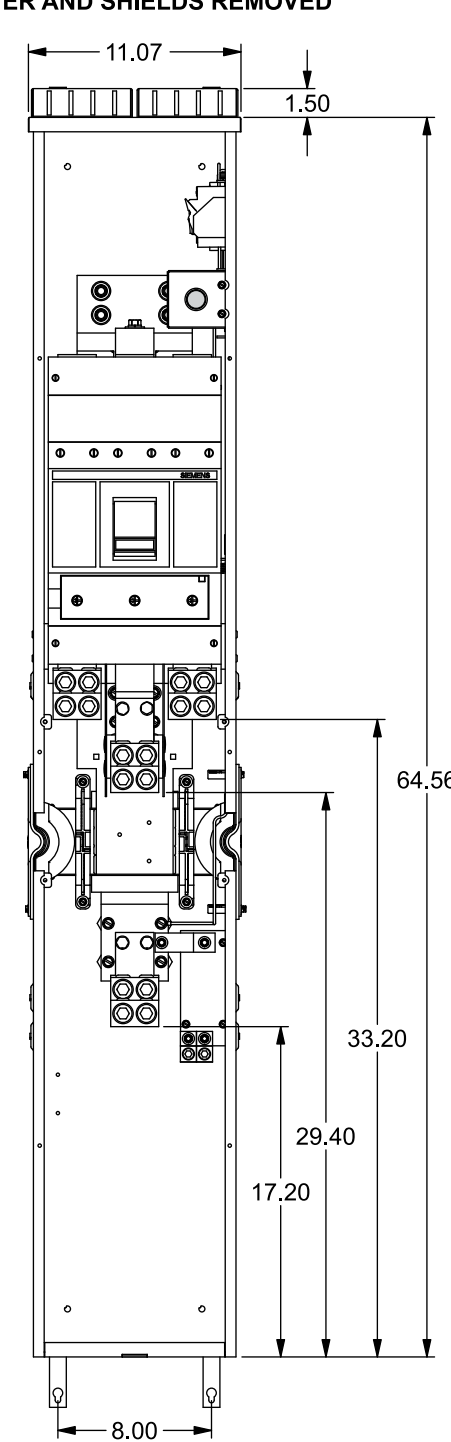
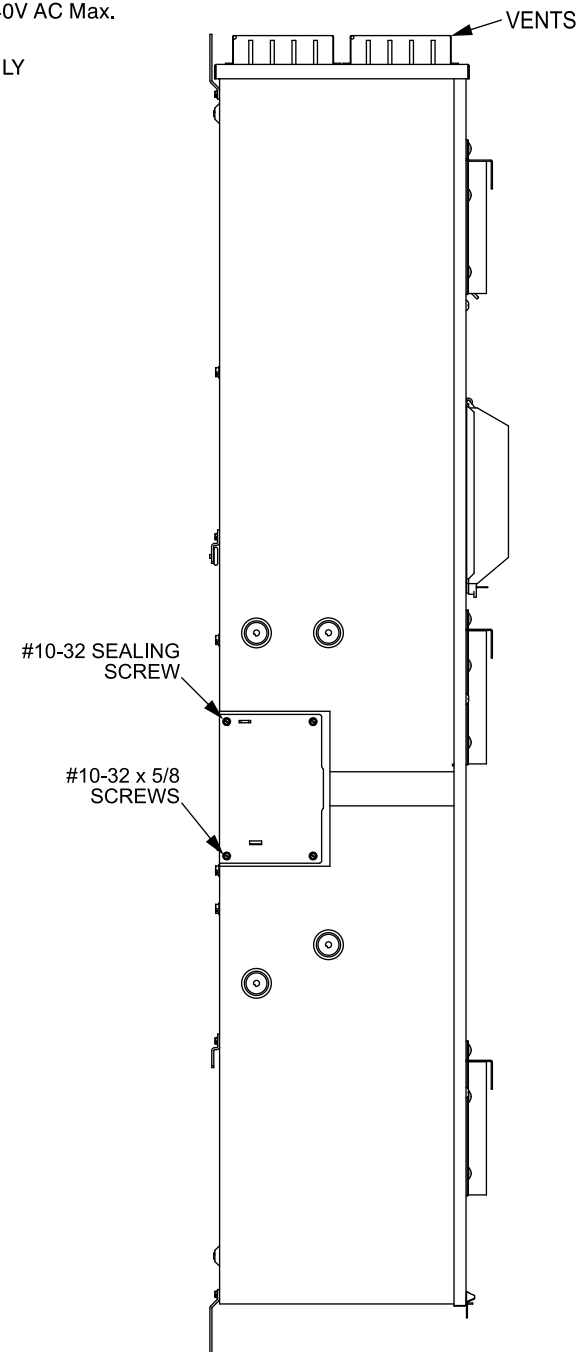

© 2018 Copyright Siemens Industry, Inc.

SIEMENS
Siemens Industry, Inc.

PowerMod™ Breaker Mains

Description: **1200A, 3 Phase, Bottom Feed, w/DAS® Breaker Skinny Mains**

KAM 8/6/18 DO NOT SCALE DRAWING Dwg. No. **WBM31200B-BU**