

Installation Instructions



DANGER

Hazardous voltage.
Will cause death or severe injury.

Turn off and lock out all power before installing this device.

Replace the covers and shields before power supplying this device is restored.

SAFETY INSTRUCTIONS

1. Turn off power feeding this device before starting the installation.
2. Also turn off any line power within the immediate vicinity to prevent the incidental or accidental contact of tools by the installer.

Note: This instruction sheet outlines the recommended installation procedure for the following Neutral Sensors:

Neutral Sensor Cat. No.	Neutral Sensor Ampere Rating
N02SJD	200 Amps
N03SJD	300 Amps
N04SJD	400 Amps
N05SLD	500 Amps
N06SLD	600 Amps

CAUTION

Incorrect neutral sensor could cause nuisance tripping or improper operation of the ground fault function.

Use only the above series of neutral sensors.

The Ampere Rating of the neutral sensor must match the Maximum Continuous Current rating (In) of the Circuit Breaker.

This neutral sensor is designed to be mounted on one 3.00" x .50" bus bar or, two 500 MCM cables, maximum.

Mounting:

Position the neutral sensor within easy wiring range of the associated circuit breaker and fabricate two .312 diameter holes 2.25 inches apart in bus or panel, as shown in Figure 1. Orient L — Mounting brackets as necessary for the mounting configuration being used and secure to the neutral sensor with the hardware provided.

Mount the neutral sensor to bus or panel with 1/4-20 hardware (not provided).

Important:

The SJD and SLD series of electronic trip circuit breakers equipped with ground fault protection may be used in the Residual or Ground Return modes. When used in the Residual mode the orientation of the neutral sensor is important for proper operation. See Figures 2 and 3 for proper orientation of the neutral sensor for Residual mode Ground Fault. Orientation of the neutral sensor is not required when used in the Ground Return mode of Ground Fault. See Figure 4 for installation of neutral sensor.

Terminal Connections:

After properly orienting and mounting the neutral sensor, maintain the correct polarity by attaching the white lead from the circuit breaker to terminal X1 of the neutral sensor, and the black lead to terminal X2.

<u>Hardware List:</u>	<u>Quantity</u>
10-32 Terminal Screw	2
#10 Lockwasher	2
Cupped Washer	2
L Mounting Bracket	2
1/4-20 x 5/8" machine screw	2
1/4" lockwasher	2
Breaker Label	1

Breaker Label (Figure 5):

This label is to be attached to the associated circuit breaker at installation.



⚠ DANGER
 Hazardous voltage.
 Will cause death or severe injury.
 Turn off and lock out all power before installing this device.
 Replace the covers and shields before power supplying this device is restored.

Installation Instructions

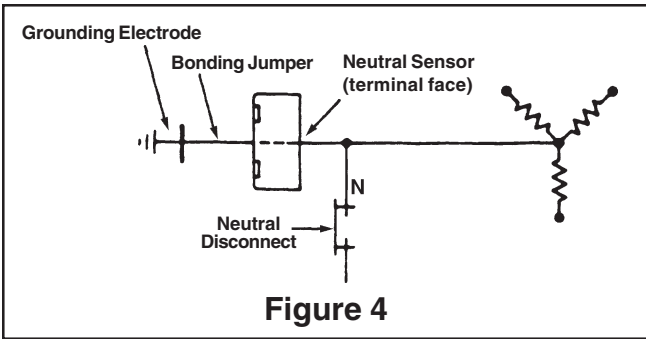
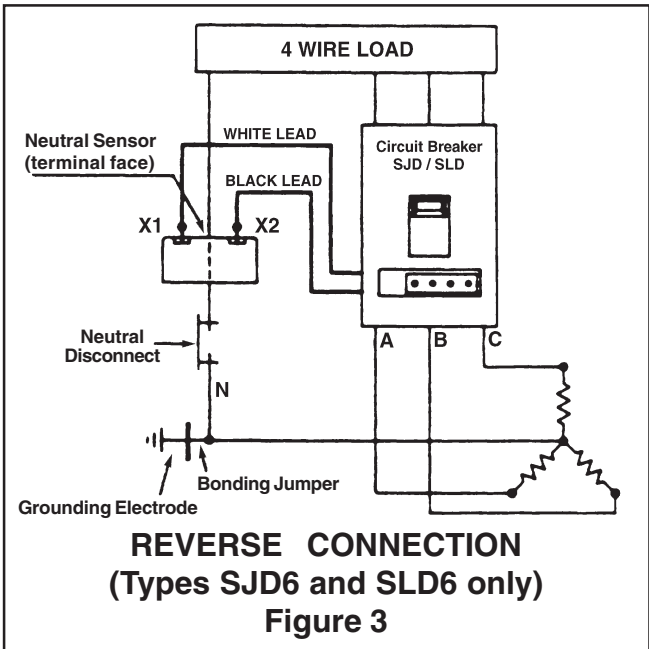
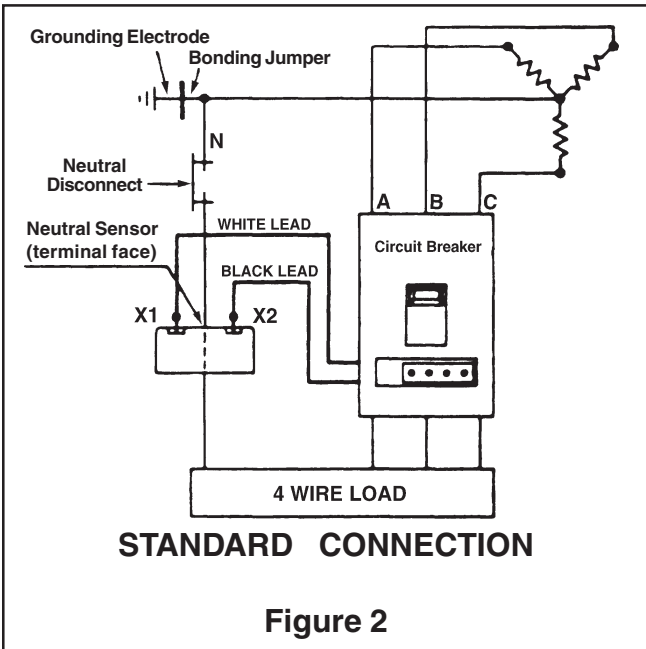
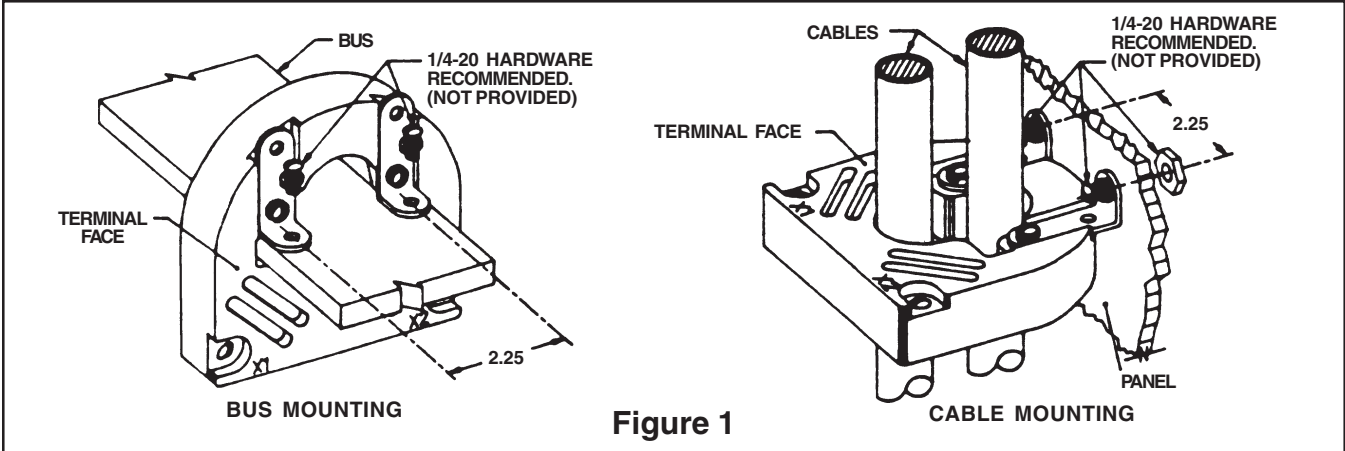

BREAKER IS EQUIPPED WITH A NEUTRAL SENSING TRANSFORMER

720219-A00

Figure 5