

SIEMENS



SIMATIC

S7-1500 / ET 200MP

Digital input module DI 32x24VDC BA (6ES7521-1BL10-0AA0)

Manual

Edition

12/2016

siemens.com

SIEMENS

SIMATIC

S7-1500/ET 200MP
Digital input module
DI 32x24VDC BA
(6ES7521-1BL10-0AA0)

Manual

Preface

Documentation guide

1

Product overview

2

Wiring

3

Address space

4

Diagnostics alarms

5

Technical specifications

6

Dimensional drawing

A

Legal information

Warning notice system

This manual contains notices you have to observe in order to ensure your personal safety, as well as to prevent damage to property. The notices referring to your personal safety are highlighted in the manual by a safety alert symbol, notices referring only to property damage have no safety alert symbol. These notices shown below are graded according to the degree of danger.

DANGER

indicates that death or severe personal injury **will** result if proper precautions are not taken.

WARNING

indicates that death or severe personal injury **may** result if proper precautions are not taken.

CAUTION

indicates that minor personal injury can result if proper precautions are not taken.

NOTICE

indicates that property damage can result if proper precautions are not taken.

If more than one degree of danger is present, the warning notice representing the highest degree of danger will be used. A notice warning of injury to persons with a safety alert symbol may also include a warning relating to property damage.

Qualified Personnel

The product/system described in this documentation may be operated only by **personnel qualified** for the specific task in accordance with the relevant documentation, in particular its warning notices and safety instructions. Qualified personnel are those who, based on their training and experience, are capable of identifying risks and avoiding potential hazards when working with these products/systems.

Proper use of Siemens products

Note the following:

WARNING

Siemens products may only be used for the applications described in the catalog and in the relevant technical documentation. If products and components from other manufacturers are used, these must be recommended or approved by Siemens. Proper transport, storage, installation, assembly, commissioning, operation and maintenance are required to ensure that the products operate safely and without any problems. The permissible ambient conditions must be complied with. The information in the relevant documentation must be observed.

Trademarks

All names identified by ® are registered trademarks of Siemens AG. The remaining trademarks in this publication may be trademarks whose use by third parties for their own purposes could violate the rights of the owner.

Disclaimer of Liability

We have reviewed the contents of this publication to ensure consistency with the hardware and software described. Since variance cannot be precluded entirely, we cannot guarantee full consistency. However, the information in this publication is reviewed regularly and any necessary corrections are included in subsequent editions.

Preface

Purpose of the documentation

This manual supplements the S7-1500/ET 200MP (<https://support.industry.siemens.com/cs/ww/en/view/59191792>) system manual.

Functions that relate in general to the systems are described in this system manual.

The information provided in this manual and in the system/function manuals supports you in commissioning the systems.

Changes compared to previous version

Compared to the previous version, this manual contains the following change:

Schematic circuit diagram has been updated.

Conventions

The term "CPU" is used in this manual both for the CPUs of the S7-1500 automation system and for interface modules of the ET 200MP distributed I/O system.

Please also observe notes marked as follows:

Note

A note contains important information on the product described in the documentation, on the handling of the product or on the section of the documentation to which particular attention should be paid.

Security information

Siemens provides products and solutions with industrial security functions that support the secure operation of plants, systems, machines and networks.

In order to protect plants, systems, machines and networks against cyber threats, it is necessary to implement – and continuously maintain – a holistic, state-of-the-art industrial security concept. Siemens' products and solutions only form one element of such a concept.

Customer is responsible to prevent unauthorized access to its plants, systems, machines and networks. Systems, machines and components should only be connected to the enterprise network or the internet if and to the extent necessary and with appropriate security measures (e.g. use of firewalls and network segmentation) in place.

Additionally, Siemens' guidance on appropriate security measures should be taken into account. For more information about industrial security, please visit (<http://www.siemens.com/industrialsecurity>).

Siemens' products and solutions undergo continuous development to make them more secure. Siemens strongly recommends to apply product updates as soon as available and to always use the latest product versions. Use of product versions that are no longer supported, and failure to apply latest updates may increase customer's exposure to cyber threats.

To stay informed about product updates, subscribe to the Siemens Industrial Security RSS Feed under (<http://www.siemens.com/industrialsecurity>).

Open Source Software

Open-source software is used in the firmware of the I/O modules. Open Source Software is provided free of charge. We are liable for the product described, including the open-source software contained in it, pursuant to the conditions applicable to the product. Siemens accepts no liability for the use of the open source software over and above the intended program sequence, or for any faults caused by modifications to the software.

For legal reasons, we are obliged to publish the original text of the license conditions and copyright notices. Please read the information relating to this on the Internet (<https://support.industry.siemens.com/cs/ww/en/view/109741045>).

Table of contents

| | | |
|----------|---------------------------------------|-----------|
| | Preface | 4 |
| 1 | Documentation guide | 7 |
| 2 | Product overview | 11 |
| | 2.1 Properties | 11 |
| 3 | Wiring | 13 |
| | 3.1 Wiring and block diagram | 13 |
| 4 | Address space | 14 |
| | 4.1 Address space | 14 |
| 5 | Diagnostics alarms | 18 |
| | 5.1 Status and error displays | 18 |
| 6 | Technical specifications | 20 |
| A | Dimensional drawing | 23 |

Documentation guide

The documentation for the SIMATIC S7-1500 automation system, the CPU 1516pro-2 PN based on SIMATIC S7-1500 and the SIMATIC ET 200MP distributed I/O system is arranged into three areas.

This arrangement enables you to access the specific content you require.

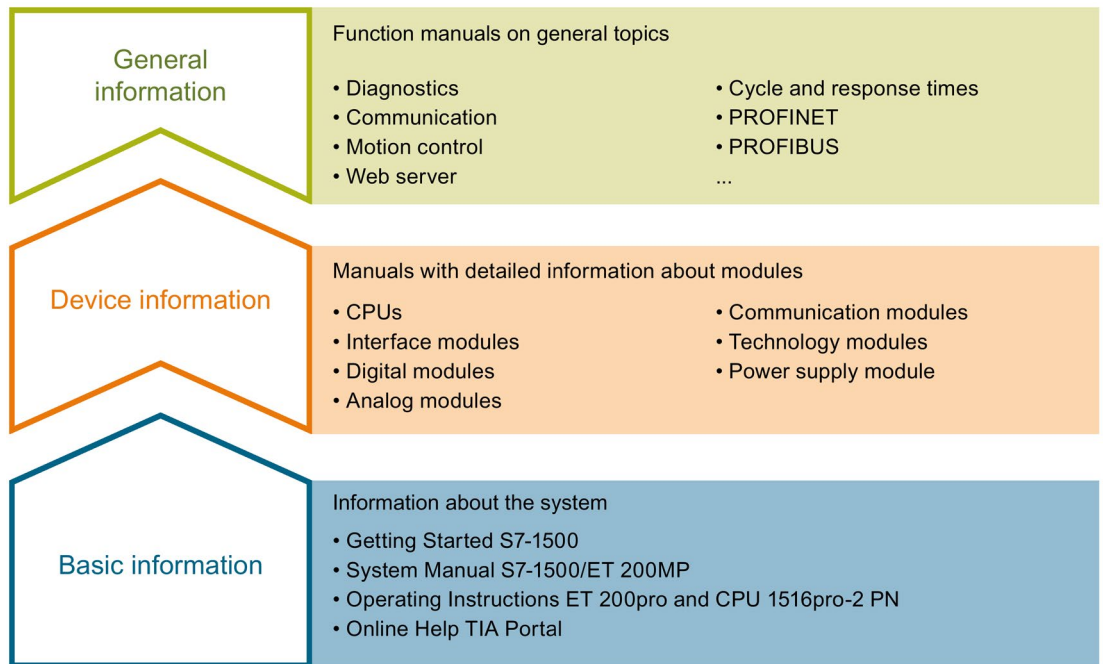

Basic information

The System Manual and Getting Started describe in detail the configuration, installation, wiring and commissioning of the SIMATIC S7-1500 and ET 200MP systems. For CPU 1516pro-2 PN you use the corresponding operating instructions. The STEP 7 online help supports you in the configuration and programming.

Device information

Product manuals contain a compact description of the module-specific information, such as properties, wiring diagrams, characteristics and technical specifications.

General information

The function manuals contain detailed descriptions on general topics regarding the SIMATIC S7-1500 and ET 200MP systems, e.g. diagnostics, communication, motion control, Web server, OPC UA.

You can download the documentation free of charge from the Internet (<http://w3.siemens.com/mcms/industrial-automation-systems-simatic/en/manual-overview/Pages/Default.aspx>).

Changes and supplements to the manuals are documented in a Product Information.

You can download the product information free of charge from the Internet (<https://support.industry.siemens.com/cs/us/en/view/68052815>).

Manual Collection S7-1500/ET 200MP

The Manual Collection contains the complete documentation on the SIMATIC S7-1500 automation system and the ET 200MP distributed I/O system gathered together in one file.

You can find the Manual Collection on the Internet (<https://support.industry.siemens.com/cs/ww/en/view/86140384>).

SIMATIC S7-1500 comparison list for programming languages

The comparison list contains an overview of which instructions and functions you can use for which controller families.

You can find the comparison list on the Internet (<https://support.industry.siemens.com/cs/ww/en/view/86630375>).

"mySupport"

With "mySupport", your personal workspace, you make the best out of your Industry Online Support.

In "mySupport", you can save filters, favorites and tags, request CAx data and compile your personal library in the Documentation area. In addition, your data is already filled out in support requests and you can get an overview of your current requests at any time.

You must register once to use the full functionality of "mySupport".

You can find "mySupport" on the Internet (<https://support.industry.siemens.com/My/ww/en>).

"mySupport" - Documentation

In the Documentation area in "mySupport" you can combine entire manuals or only parts of these to your own manual.

You can export the manual as PDF file or in a format that can be edited later.

You can find "mySupport" - Documentation on the Internet (<http://support.industry.siemens.com/My/ww/en/documentation>).

"mySupport" - CAx data

In the CAx data area in "mySupport", you can access the current product data for your CAx or CAe system.

You configure your own download package with a few clicks.

In doing so you can select:

- Product images, 2D dimension drawings, 3D models, internal circuit diagrams, EPLAN macro files
- Manuals, characteristics, operating manuals, certificates
- Product master data

You can find "mySupport" - CAx data on the Internet (<http://support.industry.siemens.com/my/ww/en/CAxOnline>).

Application examples

The application examples support you with various tools and examples for solving your automation tasks. Solutions are shown in interplay with multiple components in the system - separated from the focus on individual products.

You will find the application examples on the Internet (<https://support.industry.siemens.com/sc/ww/en/sc/2054>).

TIA Selection Tool

With the TIA Selection Tool, you can select, configure and order devices for Totally Integrated Automation (TIA).

This tool is the successor of the SIMATIC Selection Tool and combines the known configurators for automation technology into one tool.

With the TIA Selection Tool, you can generate a complete order list from your product selection or product configuration.

You can find the TIA Selection Tool on the Internet (<http://w3.siemens.com/mcms/topics/en/simatic/tia-selection-tool>).

SIMATIC Automation Tool

You can use the SIMATIC Automation Tool to run commissioning and maintenance activities simultaneously on various SIMATIC S7 stations as a bulk operation independently of the TIA Portal.

The SIMATIC Automation Tool provides a multitude of functions:

- Scanning of a PROFINET/Ethernet network and identification of all connected CPUs
- Address assignment (IP, subnet, gateway) and station name (PROFINET device) to a CPU
- Transfer of the date and the programming device/PC time converted to UTC time to the module
- Program download to CPU
- Operating mode switchover RUN/STOP
- Localization of the CPU by means of LED flashing
- Reading out CPU error information
- Reading the CPU diagnostic buffer
- Reset to factory settings
- Updating the firmware of the CPU and connected modules

You can find the SIMATIC Automation Tool on the Internet (<https://support.industry.siemens.com/cs/ww/en/view/98161300>).

PRONETA

With SIEMENS PRONETA (PROFINET network analysis), you analyze the PROFINET network during commissioning. PRONETA features two core functions:

- The topology overview independently scans PROFINET and all connected components.
- The IO check is a fast test of the wiring and the module configuration of a system.

You can find SIEMENS PRONETA on the Internet (<https://support.industry.siemens.com/cs/ww/en/view/67460624>).

Product overview

2.1 Properties

Part number:

6ES7521-1BL10-0AA0

View of the module

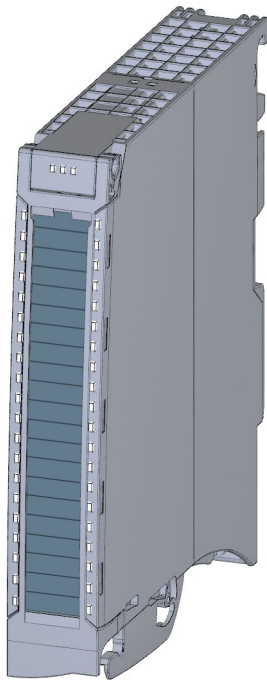

Figure 2-1 View of the DI 32x24VDC BA module

Properties

The module has the following technical properties:

- 32 digital inputs; electrically isolated in groups of 16
- Rated input voltage 24 VDC
- Suitable for switches and 2-/3-/4-wire proximity switches
- Hardware compatible with digital input module DI 16x24VDC BA (6ES7521-1BH10-0AA0)

The module supports the following functions:

Table 2- 1 Version dependencies of the module functions

| Function | Firmware version of the module | Configuration software | |
|---|--------------------------------|---|---|
| | | STEP 7 (TIA Portal) | GSD file in STEP 7 (TIA Portal) V12 or higher, or STEP 7 V5.5 SP3 or higher |
| Firmware update | V1.0.0 or higher | V13 or higher | X |
| Identification data I&M0 to I&M3 | V1.0.0 or higher | V13 or higher | X |
| Module-internal Shared Input (MSI) | V1.0.0 or higher | V13 Update 3 or higher (PROFINET IO only) | X (PROFINET IO only) |
| Configurable submodules / sub-modules for Shared Device | V1.0.0 or higher | V13 Update 3 or higher (PROFINET IO only) | X (PROFINET IO only) |

You can configure the module with STEP 7 (TIA Portal) and with a GSD file.

Accessories

The following accessories are supplied with the module and can also be ordered separately as spare parts:

- Front connector (push-in terminals) including cable tie
- Labeling strips
- U connector
- Universal front door

You can find additional information on accessories in the S7-1500/ET 200MP (<http://support.automation.siemens.com/WW/view/en/59191792>) system manual.

Wiring

3.1 Wiring and block diagram

This section contains the block diagram of the module and outlines various wiring options.

You can find information on wiring the front connector, creating a cable shield, etc. in the Wiring section of the S7-1500/ET 200MP

(<http://support.automation.siemens.com/WW/view/en/59191792>) system manual.

Wiring and block diagram

The figure below shows you how to wire the module and the assignment of the channels to the addresses (input byte a to input byte d).

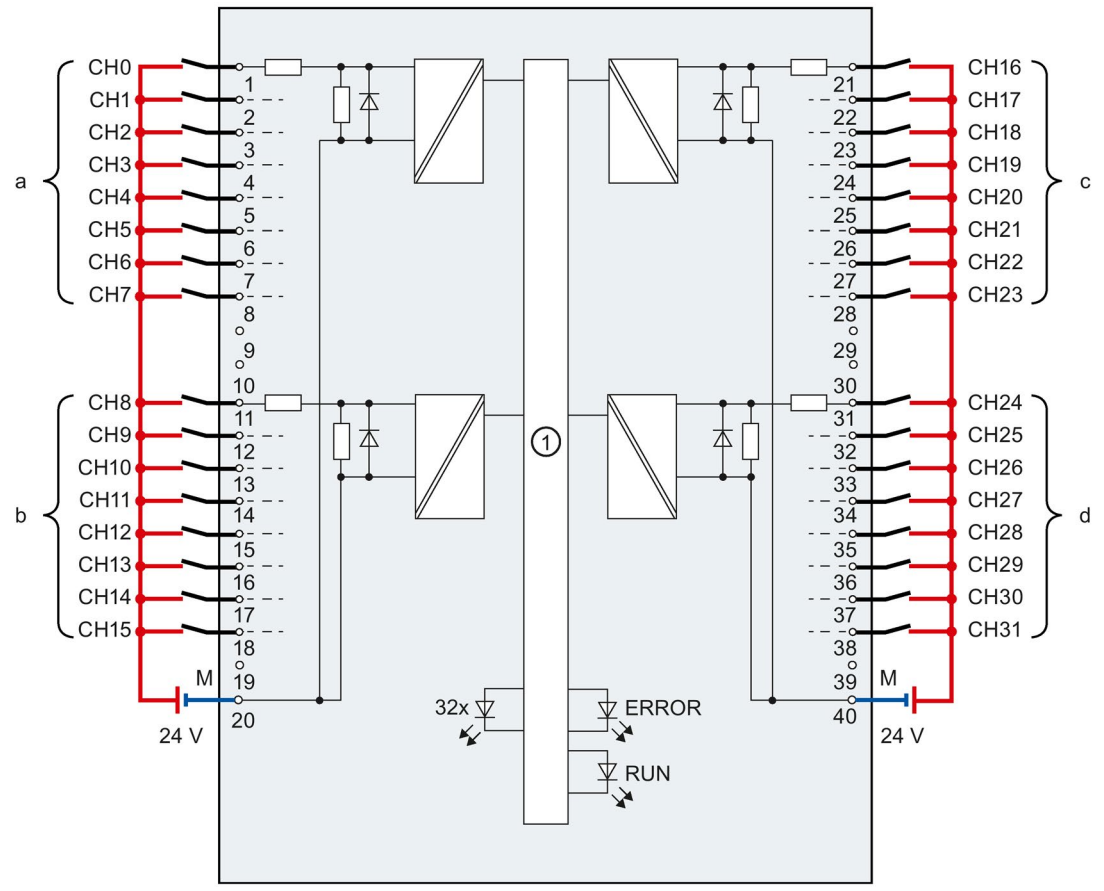

- ① Backplane bus interface
- M Ground
- CHx Channel or channel status LED (green)
- RUN Status display LED (green)
- ERROR Error display LED (red)

Figure 3-1 Block diagram and terminal assignment

Address space

4.1 Address space

The module can be configured in various ways in STEP 7. Depending on the configuration, additional/different addresses are assigned in the process image of the inputs.

Configuration options of DI 32x24VDC BA

You can configure the module with STEP 7 (TIA Portal) or with a GSD file.

When you configure the module by means of the GSD file, the configurations are available under different abbreviations/module names.

The following configurations are possible:

Table 4- 1 Configuration options

| Configuration | Short designation/ module name in the GSD file | Configuration software, e.g., with STEP 7 (TIA Portal) | |
|---|--|--|---|
| | | Integrated in hardware catalog STEP 7 (TIA Portal) | GSD file in STEP 7 (TIA Portal) V12 or higher or STEP 7 V5.5 SP3 or higher |
| 1 x 32-channel without value status | DI 32x24VDC BA | V13 or higher | X |
| 4 x 8-channel without value status | DI 32x24VDC BA S | V13 Update 3 or higher (PROFINET IO only) | X (PROFINET IO only) |
| 1 x 32-channel with value status for module-internal Shared Input with up to 4 submodules | DI 32x24VDC BA MSI | V13 Update 3 or higher (PROFINET IO only) | X (PROFINET IO only) |

4.1 Address space

Value status (Quality Information, QI)

The meaning of the value status depends on the submodule involved.

For the 1st submodule (=basic submodule), the value status is not relevant.

For the 2nd to 4th submodule (=MSI submodule), the value status 0 indicates that the value is incorrect or the basic submodule has not yet been configured (not ready).

The figure below shows the assignment of the address space with submodules 1 and 2.

Assignment in the process image input (PII) for 1st and 2nd submodule

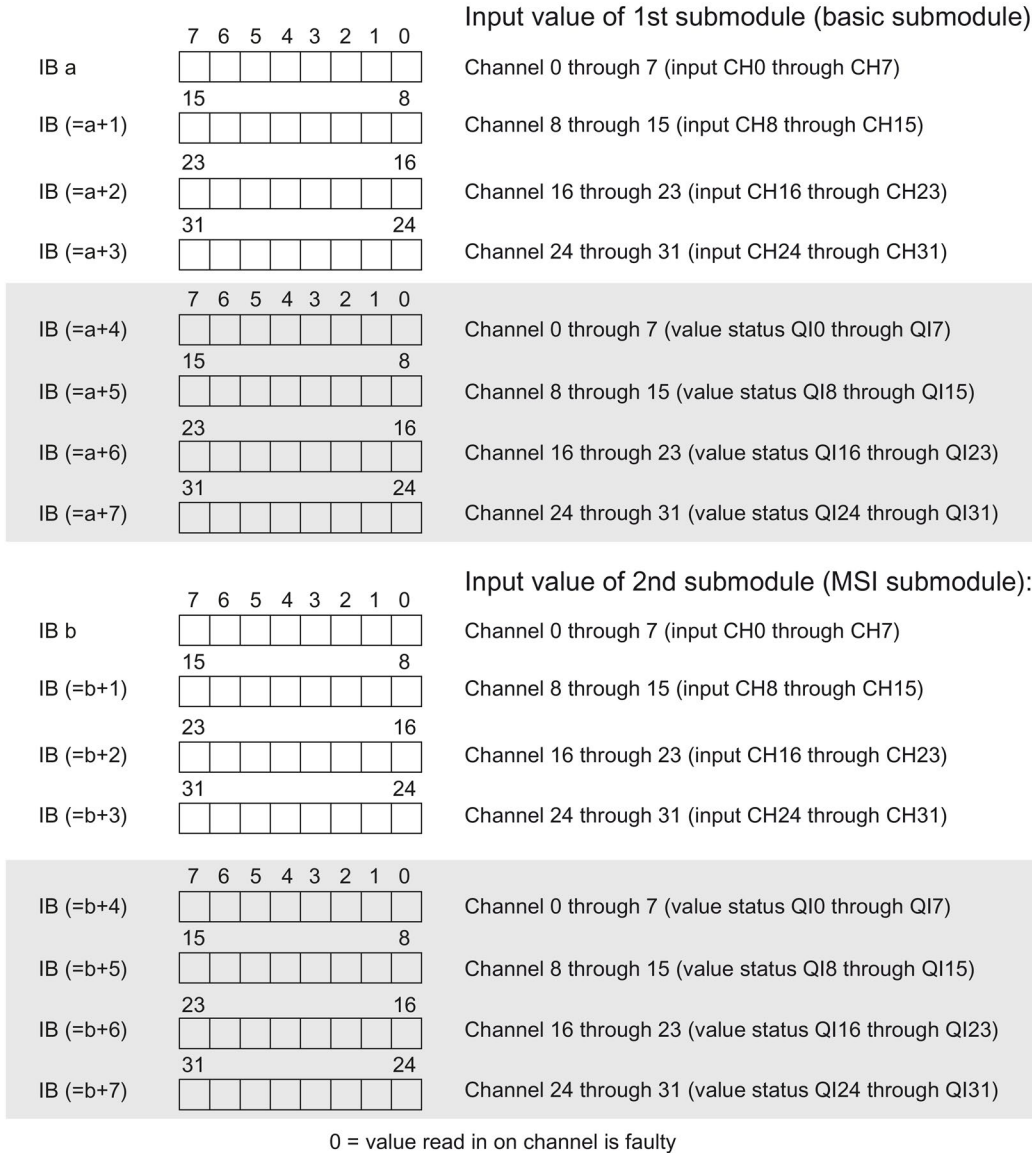

Figure 4-3 Address space for configuration as 1 x 32-channel DI 32x24VDC BA MSI with value status

Diagnostics alarms

The module has no selectable diagnostics. Diagnostics alarms, for example, cannot be output with STEP 7 (TIA Portal).

5.1 Status and error displays

LED displays

The figure below shows you the LED displays (status and error displays) of the DI 32x24VDC BA.

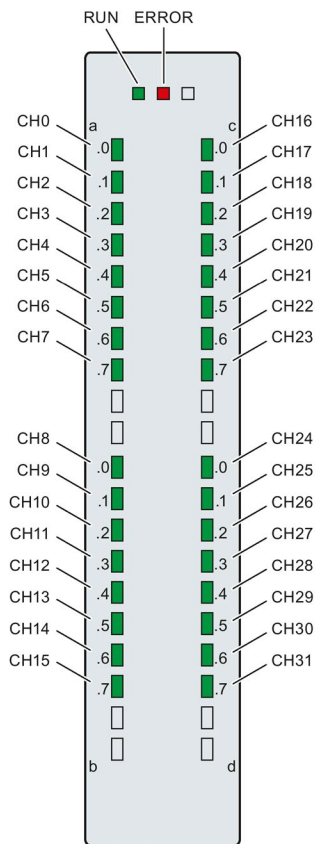

Figure 5-1 LED displays of the module DI 32x24VDC BA

Meaning of the LED displays

The tables below explain the meaning of the status and error displays.

LED RUN/ERROR

Table 5- 1 RUN/ERROR status and error displays

| LED | | Meaning | Remedy |
|--------------|--------------|--|---|
| RUN | ERROR | | |
| □ Off | □ Off | Voltage missing or too low at backplane bus. | <ul style="list-style-type: none"> • Switch on the CPU and/or the system power supply modules. • Verify that the U connectors are inserted. • Check to see if too many modules are inserted. |
| ☀ Flashes | □ Off | Module is starting up. | --- |
| ■ On | □ Off | Module is ready. | --- |
| ☀ Flashes | ☀ Flashes | Hardware defective. | Replace the module. |

LED CHx

Table 5- 2 CHx status display

| LED CHx | Meaning | Remedy |
|----------|---------------------------------|--------|
| □ Off | 0 = Status of the input signal. | --- |
| ■ On | 1 = Status of the input signal. | --- |

Technical specifications

Technical specifications of the DI 32x24VDC BA

| | 6ES7521-1BL10-0AA0 |
|--|--------------------|
| General information | |
| Product type designation | DI 32x24VDC BA |
| Hardware functional status | FS01 |
| Firmware version | V1.0.0 |
| <ul style="list-style-type: none"> FW update possible | Yes |
| Product function | |
| I&M data | Yes; I&M0 to I&M3 |
| Engineering with | |
| STEP 7 TIA Portal can be configured/integrated as of version | V13 / V13 |
| STEP 7 can be configured/integrated as of version | V5.5 SP3 / - |
| PROFIBUS as of GSD version/GSD revision | V1.0 / V5.1 |
| PROFINET as of GSD version/GSD revision | V2.3 / - |
| Operating mode | |
| DI | Yes |
| Counters | No |
| MSI | Yes |
| Supply voltage | |
| Rated value (DC) | 24 V |
| Valid range, low limit (DC) | 20.4 V |
| Valid range, high limit (DC) | 28.8 V |
| Power | |
| Power consumption from the backplane bus | 1.05 W |
| Power loss | |
| Power loss, typ. | 3 W |
| Digital inputs | |
| Number of inputs | 32 |
| Configurable digital inputs | No |
| Sinking/sourcing input | Sinking input |
| Input characteristic curve acc. to IEC 61131, type 3 | Yes |
| Input voltage | |
| Type of input voltage | DC |
| Rated value (DC) | 24 V |
| for signal "0" | -30 to +5 V |
| for signal "1" | +11 to +30 V |

| 6ES7521-1BL10-0AA0 | |
|--|----------------|
| Input current | |
| for signal "1", typ. | 2.7 mA |
| Input delay (for rated value of input voltage) | |
| For standard inputs | |
| • Configurable | No |
| • with "0" to "1", min. | 3 ms |
| • with "0" to "1", max. | 4 ms |
| • with "1" to "0", min. | 3 ms |
| • with "1" to "0", max. | 4 ms |
| For interrupt inputs | |
| • Configurable | No |
| for technological functions | |
| • Configurable | No |
| Cable length | |
| shielded, max. | 1000 m |
| unshielded, max. | 600 m |
| Encoders | |
| Connectable encoders | |
| 2-wire sensor | Yes |
| • Permitted quiescent current (2-wire sensor), max. | 1.5 mA |
| Isochronous mode | |
| Isochronous mode (application synchronized up to terminal) | No |
| Interrupts/diagnostics/status information | |
| Diagnostics function | No |
| Interrupts | |
| Diagnostics interrupt | No |
| Hardware interrupt | No |
| Diagnostics alarms | |
| Monitoring of supply voltage | No |
| Wire break | No |
| Short-circuit | No |
| Diagnostics indicator LED | |
| RUN LED | Yes; green LED |
| ERROR LED | Yes; red LED |
| Monitoring of supply voltage (PWR LED) | No |
| Channel status display | Yes; green LED |
| For channel diagnostics | No |
| For module diagnostics | No |
| Electrical isolation | |

| 6ES7521-1BL10-0AA0 | |
|--|--|
| Electrical isolation of channels | |
| Between the channels | No |
| Between the channels, in groups of | 16 |
| Between the channels and backplane bus | Yes |
| Between the channels and power supply of the electronics | No |
| Isolation | |
| Isolation tested with | 707 V DC (type test) |
| Ambient conditions | |
| Ambient temperature during operation | |
| Horizontal mounting position, min. | 0 °C |
| Horizontal mounting position, max. | 60 °C |
| Vertical mounting position, min. | 0 °C |
| Vertical mounting position, max. | 40 °C |
| Distributed mode | |
| Prioritized startup | Yes |
| Dimensions | |
| Width | 25 mm |
| Height | 147 mm |
| Depth | 129 mm |
| Weights | |
| Weight, approx. | 260 g |
| Miscellaneous | |
| Note: | Delivery includes 40-pin push-in front connector |

Dimensional drawing

The dimensional drawing of the module on the mounting rail, as well as a dimensional drawing with open front cover, are provided in this appendix. Always observe the specified dimensions for installation in cabinets, control rooms, etc.

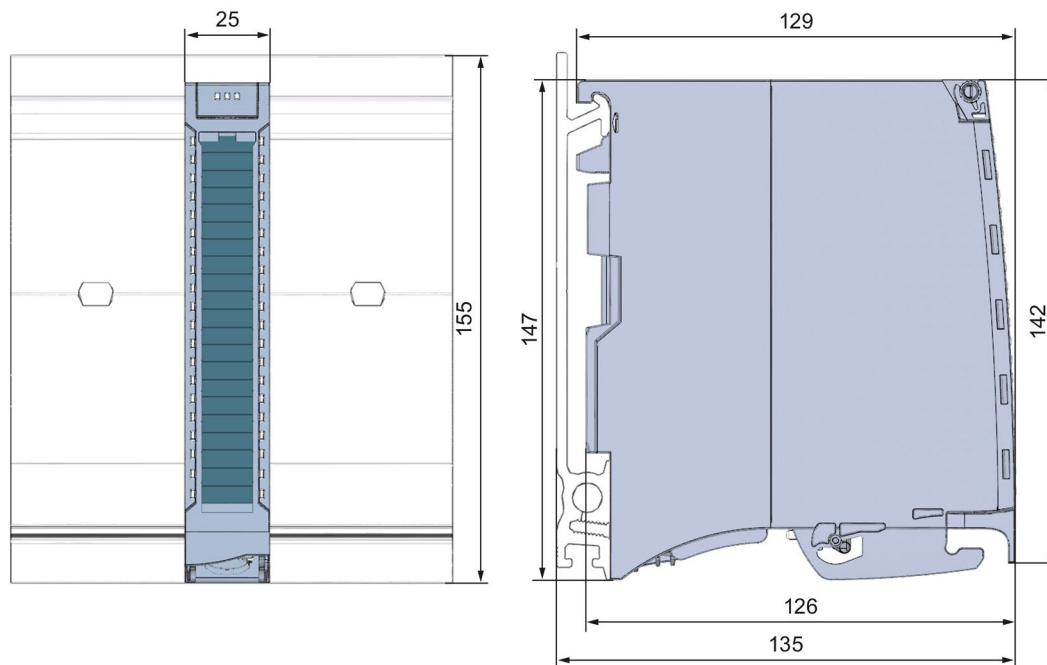

Figure A-1 Dimensional drawing of the DI 32x24VDC BA module

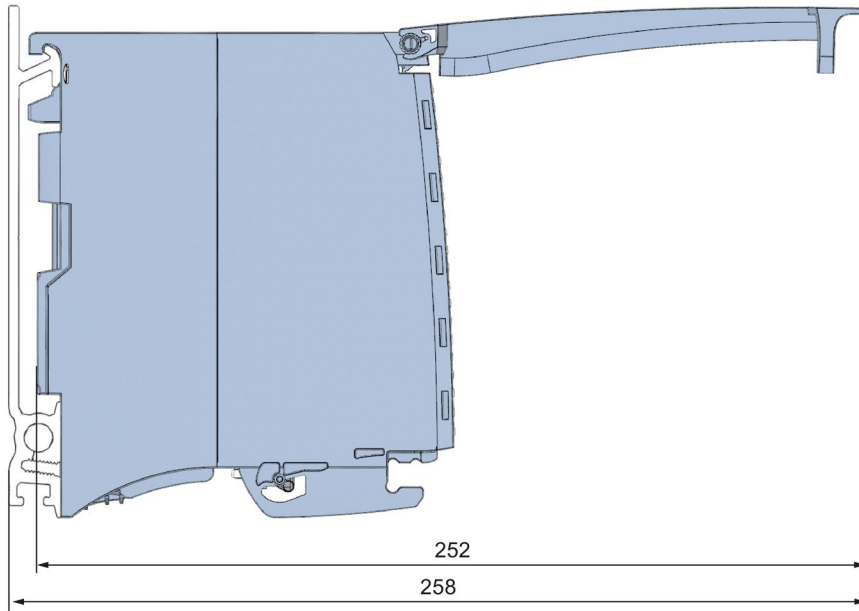

Figure A-2 Dimensional drawing of the DI 32x24VDC BA module, side view with open front cover