

SIRIUS

Hauptstrombahn-Bedämpfungsmodul

Snubber electronic circuit for main line

Écrêteur pour circuit principal



Protección de vía principal

Limitatore per circuito principale

Módulo limitador para linha principal

3RT1966-1PV3
3RT1966-1PV4



Betriebsanleitung Instructivo	Operating Instructions Istruzioni Operative	Instructions de Service Instruções de Operação
Deutsch	English	Français
Vor der Installation, dem Betrieb oder der Wartung des Geräts muss diese Anleitung gelesen und verstanden werden. Eine sichere Gerätefunktion ist nur mit zertifizierten Komponenten gewährleistet!	Read and understand these instructions before installing, operating, or maintaining the equipment. Reliable functioning of the equipment is only ensured with certified components.	Ne pas installer, utiliser ou intervenir sur cet équipement avant d'avoir lu et assimilé les présentes instructions et notamment les conseils de sécurité et mises en garde qui y figurent. La sécurité de fonctionnement de l'appareil n'est garantie qu'avec des composants certifiés.
⚠ GEFÄHR	⚠ DANGER	⚠ DANGER
 Gefährliche Spannung. Lebensgefahr oder schwere Verletzungsgefahr. Vor Beginn der Arbeiten Anlage und Gerät spannungsfrei schalten.	Hazardous voltage. Will cause death or serious injury. Turn off and lock out all power supplying this device before working on this device.	Tension électrique. Danger de mort ou risque de blessures graves. Mettre hors tension avant d'intervenir sur l'appareil.
Español	Italiano	Português
Leer y comprender este instructivo antes de la instalación, operación o mantenimiento del equipo. El funcionamiento seguro del aparato sólo está garantizado con componentes certificados.	Leggere con attenzione queste istruzioni prima di installare, utilizzare o eseguire manutenzione su questa apparecchiatura. Il funzionamento sicuro dell'apparecchiatura è garantito soltanto con componenti certificati.	Ler e compreender estas instruções antes da instalação, operação ou manutenção do equipamento. O funcionamento seguro do aparelho apenas pode ser garantido se forem utilizados componentes certificados.
⚠ PELIGRO	⚠ PERICOLO	⚠ PERIGO
 Tensión peligrosa. Puede causar la muerte o lesiones graves. Desconectar la alimentación eléctrica antes de trabajar en el equipo.	Tensione pericolosa. Può provocare morte o lesioni gravi. Scollegare l'alimentazione prima di eseguire interventi sull'apparecchiatura.	Tensão perigosa. Perigo de morte ou ferimentos graves. Desligue a corrente antes de trabalhar no equipamento.

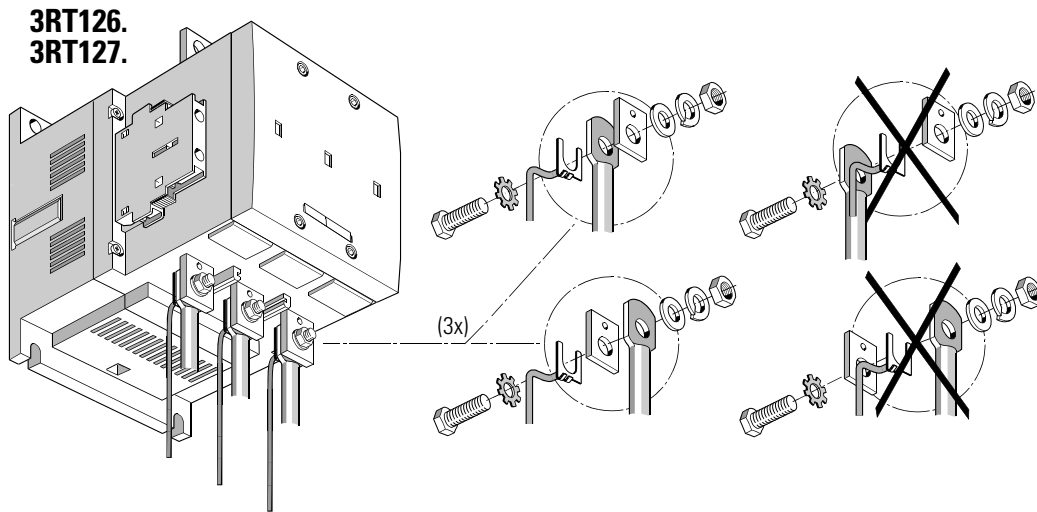

3RT1966-1PV3	$U_e \leq 690 \text{ V}$
3RT1966-1PV4	$U_e \leq 1000 \text{ V}$

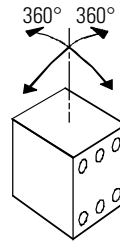
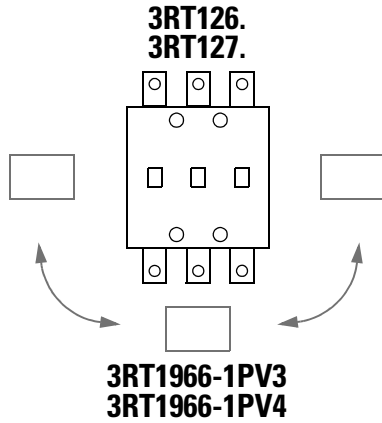
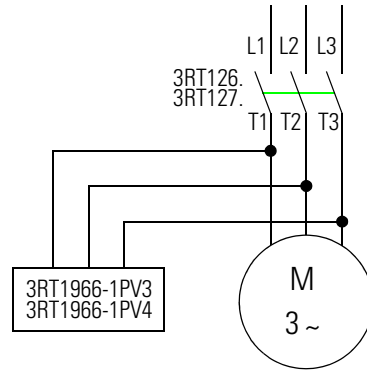

3RT1966-1PV3

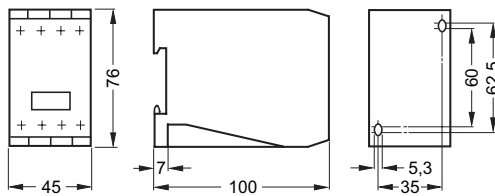

3RT1966-1PV4

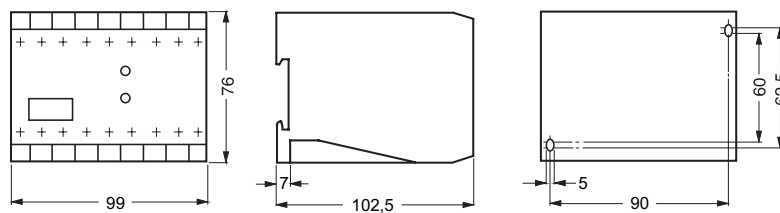

Technical Assistance: Telephone: +49 (0) 911-895-5900 (8°° - 17°° CET)
E-mail: technical-assistance@siemens.com
Internet: www.siemens.de/lowvoltage/technical-assistance

Technical Support: Telephone: +49 (0) 180 50 50 222

Fax: +49 (0) 911-895-5907