

WirelessHART Adapter

SITRANS AW210
7MP3111

User Manual · 11/2012



SITRANS

Answers for industry.

SIEMENS

Table of Contents

1	INTRODUCTION.....	3
1.1	Overview.....	3
1.2	Basic Operation.....	4
1.3	Typical Usage.....	4
1.4	Power.....	4
1.4.1	Loop Powered Mode.....	5
1.4.2	StepVolt™ Benefits.....	6
1.4.3	Direct Powered Mode.....	6
2	CONFIGURATION	7
2.1	Bench Top Hookup.....	7
2.2	Device Configuration Using Device Description (DD).....	8
3	INSTALLATION.....	9
3.1	Ordinary and Hazardous Locations.....	10
3.2	SITRANS AW210 installation to Field Device.....	11
3.2.1	Field Device Mechanical Connection.....	11
3.2.2	Antenna Positioning.....	11
3.2.3	Nameplate.....	12
3.2.4	Field Device Electrical Connection.....	12
3.2.5	Grounding.....	13
3.3	Installation Options.....	13
3.3.1	SITRANS AW210 as a Standalone WirelessHART Router (Repeater).....	13
3.3.2	SITRANS AW210 with a 4-20mA Analog only Non-HART Field Device.....	14
3.3.3	SITRANS AW210 with a HART enabled Field Device.....	14
3.3.4	SITRANS AW210 with HART Field Devices in Multi-Drop Mode.....	15
3.3.5	SITRANS AW210 with HART Field Devices in LOOP POWER Multi-Drop Mode.....	15
3.3.6	SITRANS AW210 with HART Field Devices in DIRECT POWER Multi-Drop Mode.....	16
3.3.7	SITRANS AW210 with a 4-20mA Field Device with Battery Powered Operation.....	17
4	DETAILED SETTINGS AND PARAMETER DEFINITIONS.....	17
4.1	HART Dynamic Variables.....	17
4.1.1	Configure Power Mode (method).....	17
4.1.2	Power Status.....	21
4.1.3	Join Device to Network (method).....	22
4.1.4	Network ID.....	22
4.1.5	Join Key.....	22
4.1.6	Radio Output Power.....	22
4.1.7	Scan for Devices (method).....	24
4.1.8	4-20 mA Settings.....	24
4.1.9	PV Units.....	24
4.2	Automatic Burst Mode Configuration.....	25
4.3	Factory Reset.....	25
4.4	ALERTS.....	26
4.4.1	Active Alerts.....	26
4.4.2	Alert History.....	27
4.4.3	Clear Alert (method).....	27
4.4.4	Clear All Alerts (method).....	27
4.4.5	ALERT – Direct Power Out of Range.....	27
4.4.6	ALERT – Loop Power Out of Range.....	27
4.4.7	ALERT – Temperature Out of Range.....	27
4.4.8	ALERT – Power Mode Miss configured.....	28
4.4.9	ALERT – Watchdog Reset.....	28
4.4.10	ALERT – Stack Overflow.....	28
4.4.11	ALERT – Duplicate HART Master Detected.....	29
4.4.12	ALERT – HART Devices Count Exceeded.....	29
4.4.13	ALERT – HART Sub-Device Lost.....	29
4.4.14	ALERT – Burst Packets are Being Dropped.....	30
4.4.15	ALERT – Field Device Power Control.....	30
4.4.16	ALERT – Wireless Capacity Denied.....	31
4.4.17	ALERT – Burst Message Configuration Issue.....	31
4.4.18	ALERT – Wired Device in Burst Mode.....	31
4.4.19	ALERT – SITRANS AW210 Failed to Join the Network.....	32

4.4.20	ALERT – Radio Malfunction.....	32
4.4.21	ALERT – Variable Simulation.....	32
4.4.22	ALERT – Field Device Cutoff Occurred	33
4.4.23	ALERT – Low Battery	33
4.5	HART Device Description (DD) TREE.....	34
5	MAINTENANCE	35
6	COMMISSIONING.....	35
7	TROUBLESHOOTING.....	36
8	PRODUCT ORDER INFORMATION.....	37
9	SPECIFICATIONS.....	38
10	MECHANICAL	39
10.1.1	Dimensional Drawing.....	39
10.1.2	Enclosure.....	39
11	CERTIFICATIONS.....	40
11.1	European Directive Information.....	40
11.2	Telecommunication Compliance	40
11.2.1	FCC & IC	40
11.2.2	R&TTE.....	40
11.3	Ordinary Locations Certifications	40
11.4	Hazardous Location Certificates	40
11.4.1	North America Certificates	41
11.4.2	European (ATEX) Certificates.....	43
11.4.3	IEC Certificates	44
11.4.4	Required Certification Notices and Warnings.....	45
12	CONTROL DRAWING	47

1 Introduction

1.1 Overview

The SITRANS AW210 enables new and existing wired HART field devices to communicate with host applications by means of *WirelessHART*[®] technology. The SITRANS AW210 is permanently installed by attaching it directly into an available spare port of a HART field device, or by means of using a short, right angle elbow conduit connector. The SITRANS AW210 can be inserted anywhere on the loop using a junction box or T-fitting. A wired HART field device retrofitted with a SITRANS AW210 communicates its PV over the existing wire and simultaneously communicates the PV, SV, TV and QV as well as diagnostic and alarm data over the *WirelessHART* network to process control, asset management and other automation and engineering applications. The SITRANS AW210 power configuration options are either existing loop power (scavenging) or local/direct power. The SITRANS AW210 when loop powered saves users the long term cost of battery maintenance, replacement and disposal programs. The SITRANS AW210 Local/Direct power option can be used when the field device is powered either by a DC power supply or an external battery/solar system. In the case of external battery power, the SITRANS AW210 provides battery power management by cycling the field device power and taking periodic readings.

Typical Use Cases

- Upgrade legacy wired HART or analog only field devices with WirelessHART communication capability to communicate the PV and other device data and diagnostic information to the gateway and ultimately the host application.
- Access HART device diagnostic information in HART-enabled devices in order to lower maintenance cost and improve plant operations
- Low cost wireless access to stranded monitoring and control data from improved
 - Asset management
 - Condition monitoring
 - Device diagnostics
- Connect up to 8 HART devices using only 1 SITRANS AW210 – making WirelessHART more cost effective
- Remote IO applications of hard to reach locations
- Substitute for multiplexers or legacy DCS upgrade to HART-enabled I/O.
- External Battery powered wireless remote I/O data collection
- Low cost / low risk means to test and evaluate WirelessHART networks
- Monitor / control of rotating and mobile equipment

Features

- HART Registered fully HART compliant for communication reliability Universal connectivity – works with all registered HART devices
- Supports *WirelessHART* MESH and STAR network configurations
- Loop powered – no batteries or other power sources required
- Connects directly to HART field device and optionally anywhere on the 4-20 mA control loop
- StepVolt™ technology sets insertion voltage in steps from 1 to 2.5 volts to optimize the tradeoff between available loop power and Wireless communication bandwidth.
- Direct Power option when local DC power is available: system power, external battery/solar system.
- In Direct Power mode, can switch field device on/off to take periodic readings to save power
- Internal 250 Ohm loop current sense and HART terminating resistor provided, configurable by *WirelessHART* command
- Multidrop support for up to 8 devices (maximum number depends on installation)
- 235 meters open air range (nominal)
- Rugged internal antenna design

1.2 Basic Operation

The SITRANS AW210 *WirelessHART*[®] Adapter allows new and existing wired-HART devices to be connected integrated into a *WirelessHART* network. This allows remote access to diagnostic data, digital process variables, and alarm data stored inside HART devices.

The SITRANS AW210 has both a *Wireless* interface to communicate with the *WirelessHART* network and a wired-HART interface to communicate to a traditional 4-20mA current loop device. The SITRANS AW210 communicates as a wired-HART master to connected HART devices on the loop, and can transmit and receive HART data from these connected HART devices to the *WirelessHART* network. The SITRANS AW210 also supports being configured like a wired-HART slave device, so traditional HART configuration tools (such as HART Field Communicators and PCs with HART modems) can be used to configure the SITRANS AW210.

In *WirelessHART* terminology, any wired-HART devices that can be communicated with a *WirelessHART* Adapter are known as a sub-device. A single SITRANS AW210 *WirelessHART* Adapter can support up to eight (8) wired-HART sub-devices. The *WirelessHART* Gateway maintains a list of all of the devices in the *WirelessHART* network, including sub-devices connected to *WirelessHART* Adapters. Host applications that communicate with the *WirelessHART* gateway communicates in-directly with the wired-HART sub-device through the *WirelessHART* Adapter. The *WirelessHART* gateway and *WirelessHART* Adapter transparently handle the message conversion between the Host application and wired-HART sub-device.

WirelessHART supports publishing of data from devices to the *WirelessHART* Gateway on a periodic basis. This is called “burst mode” in HART terms, but is much more advanced than the “burst mode” traditionally supported by HART devices. Data can be burst based on an user defined update time or by a user specified triggered event; such as a process variable alarm.

When the SITRANS AW210 is configured in burst mode, it supports all of these advanced modes on behalf of any connected wired-HART sub-devices.. Burst mode is also very useful to publish device status data (such as malfunctions or alarms) to the Gateway on a periodic basis or immediately when a critical event occurs.

1.3 Typical Usage

In most typical network configurations, the SITRANS AW210 will be used in conjunction with a wired-HART sub-device and configured to publish process data and device status data from the connected sub-device to the *WirelessHART* network on a user defined periodic basis (such as every 8 seconds or every minute, etc).

The SITRANS AW210 adds several features to make this typical usage mode very easy to configure, such as the Automatic Sub-Device detection and Automatic Burst mode configuration.

1.4 Power

The SITRANS AW210 *WirelessHART* Adapter has been designed to be extremely power efficient and flexible to allow for a wide variety of installation options. The SITRANS AW210 can be installed to be powered by one of two sources either; 1) current loop denoted as LOOP POWER or 2) by a DC source denoted as DIRECT POWER.

1.4.1 Loop Powered Mode

The SITRANS AW210 can be wired in series with devices on a 4-20mA loop and be powered from the loop. The SITRANS AW210 utilizes **StepVolt™** technology, to allow the user to set this insertion voltage drop between 1.0 – 2.5 Volts, in 0.5 Volt increments.

StepVolt™ allows users to select the best insertion voltage drop for their application. The higher the voltage drop setting used, the more *WirelessHART*® messages the SITRANS AW210 will be able to transmit and receive.

In applications where there is very little voltage overhead in the loop, such as transmitters on very long cable runs or with IS barriers, StepVolt™ allows the selection of a low insertion voltage drop. However in typical applications there is adequate voltage overhead on the loop to allow for a higher insertion voltage drop from the SITRANS AW210.

A concern with a loop powered *WirelessHART* Adapter is being able to operate under worst case low current conditions since very little power is available to be used by the Adapter.. The SITRANS AW210 is designed to operate at the worst case operating conditions at all power settings and will respond to Wired or *WirelessHART* commands.

The SITRANS AW210 will operate as specified with reliable communications even under the following conditions:

- Loop current of 3.2mA and 1.0V insertion voltage drop
- Temperature Extremes (-40C to +85C)
- Worst Case wired-HART communication on the loop. Constant wired-HART communication addressed to the Adapter and the Adapter responding to every command.
- Every *WirelessHART* timeslot filled and transmitting

NOTES

- On power-up, the insertion voltage drop will default to 1.0V until the SITRANS AW210 has finished initialization. After initialization, the insertion voltage drop will change to the user specified value in the HART Device Description (DD).
- The SITRANS AW210 cannot control the loop current, if connected in loop-powered mode there must be device controlling the loop current, such as a 4-20mA

WARNING

IF THE SITRANS AW210 HAS AN INTERNAL FAILURE AND STOP REGULATING TO THE SPECIFIED **STEPVOLT™** VALUE, THE MAXIMUM INSERTION VOLTAGE DROP CAN RISE TO 4.935VDC.

1.4.2 StepVolt™ Benefits

The benefit to using a high StepVolt™ setting is that the SITRANS AW210 will be able to support a much higher amount of *WirelessHART*® packets per second. Even if the particular device attached to the SITRANS AW210 is configured for a very low update rate, being able to support a high amount of *WirelessHART* packets per second helps the overall *WirelessHART* network operation.

WirelessHART is a mesh network – each node in the network will route messages on behalf of other nodes in the network. This is done to expand the overall range of the network and also for the data reliability of the network by forming multiple redundant paths. By setting the SITRANS AW210 to a high StepVolt™ setting, more *WirelessHART* packets can be routed through the SITRANS AW210 for other nodes in the network.

Another consideration from a *WirelessHART* network standpoint is that many devices in a *WirelessHART* network are battery powered and all *Wireless* transmissions performed by these devices impact their battery life. The more *WirelessHART* devices that a battery powered node has to route messages for, the shorter its overall battery life.

The SITRANS AW210 is different – since it is loop powered it can support *Wireless* messages indefinitely without any concerns of battery life. By placing SITRANS AW210 at key locations in a *WirelessHART* network, such as places that route messages for other *WirelessHART* nodes, this routing function can be offloaded from battery powered nodes to the SITRANS AW210 and help to preserve their battery life of the battery powered nodes.

StepVolt Setting	<i>WirelessHART</i> Packets per Second
1.0 V	4.25
1.5 V	12.65
2.0V	19.66
2.5V	26.66

NOTES

- The value shown in *WirelessHART* Packets per second column is the value reported back in HART Command 777.
- Recommendation: Using the highest StepVolt™ setting possible will improve the overall *WirelessHART* network performance.

1.4.3 Direct Powered Mode

The SITRANS AW210 can be powered by an external DC power source such as; battery, solar panel or the DC power supply used to power the Field device. The DIRECT POWER voltage range is 7VDC to 32VDC.

The DIRECT POWER connections are; 1) DIRECT POWER, black lead wire, to the positive potential (+) and 2) RETURN, white lead wire, to the negative terminal (-) of the external DC source.

2 Configuration

This section contains information on configuration that should be performed prior to installation of the SITRANS AW210 in the field.

Initial configuration is performed through the use of a HART Device Descriptor (DD) or Device Type Manager (DTM) for the SITRANS AW210 over the wired-HART connection. Once connected to the *WirelessHART* network, configuration changes can be made using the DD/DTM over either the wired-HART interface or the *WirelessHART* interface.

2.1 Bench Top Hookup

Tools Required

- 7-32VDC Power Supply
- HART modem
- WirelessHART network settings – Network ID and Join Key
- PC with DTM Frame application (PACTware) with the SITRANS AW210 and Com DTMs installed

Before configuring the bench top configuration test setup, adjust the DIRECT POWER source to a voltage between 7- 32VDC and turn off the DIRECT POWER source.

Configure the SITRANS AW210, DIRECT POWER source and HART communicator per Figure 1.

Referring to Figure 1, connect the DIRECT POWER source positive (+) terminal to the SITRANS AW210's black lead wire and the DIRECT POWER source negative (-) terminal to the SITRANS AW210's white lead wire.

Connect HART modem to the SITRANS AW210. The SITRANS AW210's HART signal connections are polarity independent. Connect the HART modem leads to the SITRANS AW210's white lead-wire and yellow lead-wire.

Ensure the Loop Power lead wire (RED) is not connected to any terminal of the DC power Source and or Earth Ground (Green/Yellow).

Re-verify the test setup is configured per Figure 1 and then turn on the DIRECT POWER source, verify that the HART modem and PC or HART communicator is operating as expected and proceed to the following section – QUICK SETUP.

Wire Color	Description
Green / Yellow	Internal Earth Ground
Black	Direct Power
Red	Loop Power
White	Return
Yellow	HART
Ground Screw	External Earth Ground

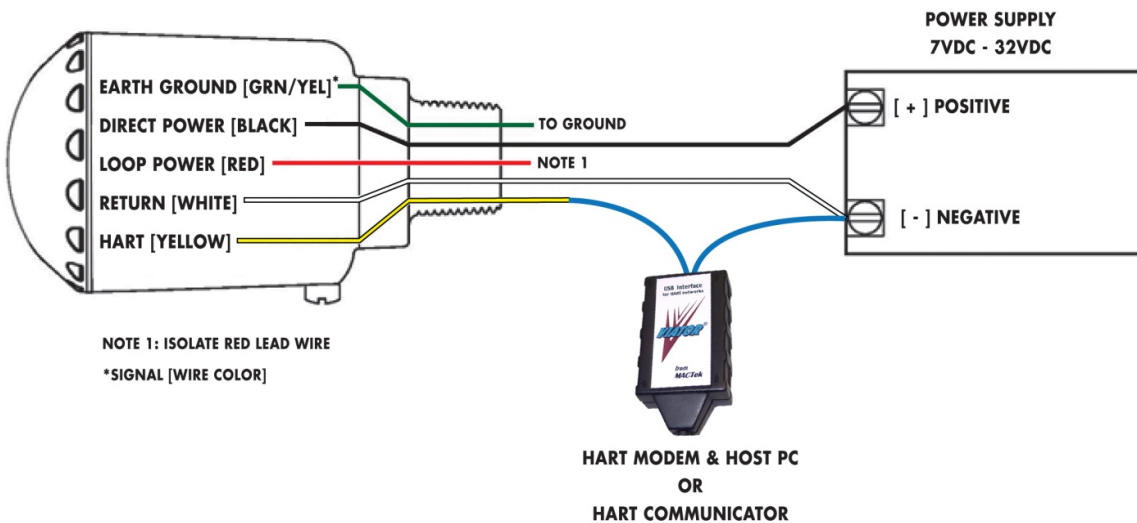

FIGURE 1: BENCH TOP CONFIGURATION SETUP

NOTES

- By default, the SITRANS AW210 is at HART polling address 15.
- By default, all WirelessHART Adapters are configured as a primary HART master. The HART communicator used to configure the SITRANS AW210 should be configured in Secondary HART master mode.

WARNING

THE SITRANS AW210 CAN BE DAMAGED IF THE DIRECT POWER SOURCE IS GREATER THAN 32VDC

2.2 Device Configuration Using Device Description (DD)

NOTE

DD and Simatic PDM Setup instruction are included in *SIEMENS* INSTALLATION CD.

There are generic instructions that should help with your DD based configurator.

Set the HART Tags for the SITRANS AW210:

1. From the Main DD screen, select Configure...
2. Select Manual Setup... SITRANS AW210 Information...
3. Enter in the HART Tag
4. Enter in the HART Long Tag
5. Transfer the updated information to the SITRANS AW210 by clicking on the "Send" or "Transfer" button

Set the Power Configuration for the SITRANS AW210:

1. From the Main DD screen, select Configure...
2. Select Guided Setup...
3. Select Configure Power Mode...
4. Follow the on screen instructions and select the proper power configuration for the application.

Configure Burst settings

1. From the Main DD screen, select Configure...
2. Select Manual Setup... Burst Settings...
3. Set the Automatic Burst Mode to the desired update rate (recommended) or set this to disabled.
4. If not using the Automatic Burst Mode, manually set the burst mode configuration for each Burst Message. *Note: Sub-devices must be detected before configuring the manual Burst Mode configuration.*
5. Transfer the updated information to the SITRANS AW210 by clicking on the "Send" or "Transfer" button

Configure *Wireless*HART Network settings

1. From the Main DD screen, select Configure...
2. Select Guided Setup...
3. Select Join Device to Network...
4. Follow the on screen instructions and enter in the *Wireless*HART Network ID and join key
5. After accepting the settings, the SITRANS AW210 will attempt to join the network if the *Wireless*HART gateway is in range.

Monitoring *Wireless*HART Network join status

1. From the Main DD screen, select Service Tools...
2. Select Communications... *Wireless* Status...
3. Monitor the progress of the *Wireless*HART join. If "Join Failed" under Join Status becomes set, check the Network ID and Join Key that were used to see that they are correct.

At this point, the SITRANS AW210 is ready to be installed and commissioned in the field. For installation information and wiring drawings proceed to Section 4 (Installation).

3 Installation

The SITRANS AW210 was designed to be extremely flexible and support a variety of installation options. A typical SITRANS AW210 installation to a field device is shown Figure 2. The SITRANS AW210 is attached to the field device using the standard commercially available hardware as required by the installation requirements and area classification. In explosion proof locations instead of fittings we recommend to use a junction box due to the increased volume.

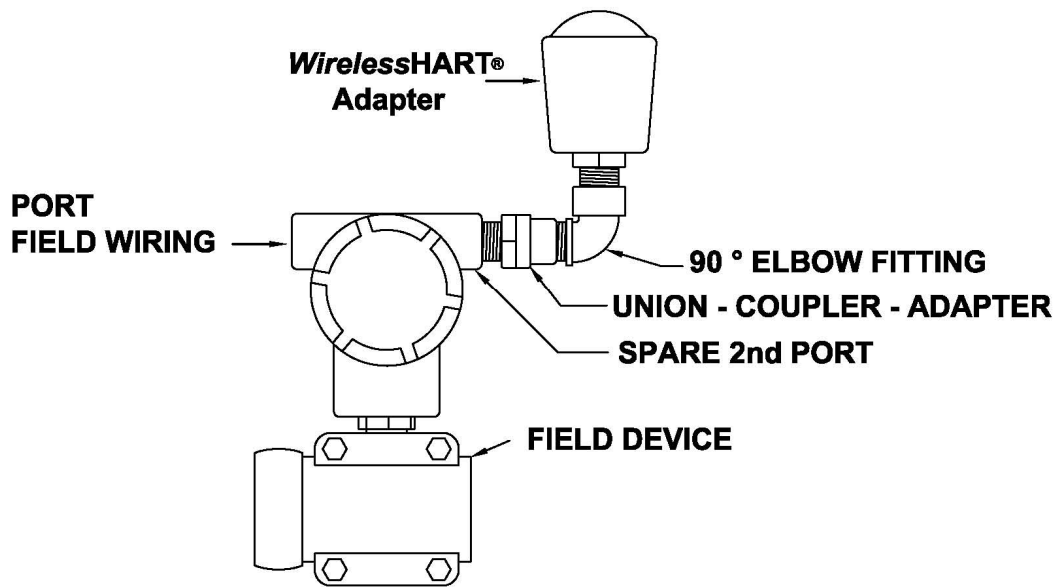

FIGURE 2: Typical SITRANS AW210 - Field Device installation

3.1 Ordinary and Hazardous Locations

The SITRANS AW210 has been approved for use in both non-classified, denoted as Ordinary Location and areas classified as Hazardous Locations denoted as; Class-Division, Class-Zone and Zone.

The model number and approval marking on the nameplate defined where the SITRANS AW210 may be installed. Refer to Section 8 Product Ordering information and Section 11 Certificates for the approval markings.

Each SITRANS AW210 nameplate located on the housing is clearly marked with that model approval markings. Verify that the selected model of the SITRANS AW210 is appropriate for that installation.

For Class-Zone and Zone installations the SITRANS AW210 nameplate is to be permanently marked to denote that installation. Refer to Section 3.2.3 Nameplate for more details.

For all installations, in areas classified as a hazardous location; denoted as, Class-Division, Class-Zone and or Zone, refer to Section 11 Certifications for any the special condition of use notices and or installation warnings.

For all installations, in areas classified as a hazardous location; denoted as, Class-Division, Class-Zone and or Zone, all fittings, junction boxes, conduit seals, cable glands, cabling, wiring, conduit and any other materials related to the installation of this product must be approved, listed and or recognized as suitable for use by a recognized approval agency, notified body and or national certification body for use in that classified area, for that specific protection type and temperature class.

Refer to Section 12 CONTROL Drawings for , Intrinsically Safe, Non-Incendive and Non-Sparking installation requirements.

No SITRANS AW210 installed in a non-Intrinsically Safe installation can be re-installed in a Intrinsically Safe installation. A non-Intrinsically Safe installation for this product includes; ordinary location, non-incendive, explosion proof and installations employing protection types nA, nC, d and tb.

WARNINGS

- INSTALLATIONS FOR EITHER ORDINARY LOCATION OR HAZARDOUS LOCATION SHOULD ONLY BE PREFORMED BY QUALIFIED PERSONAL TRAINED IN THE APPLICABLE NATIONAL, REGIONAL, LOCAL CODES AND PRACTICES.
- INSTALLATION IN EXPLOSIVE ATMOSPHERE MUST COMPLY WITH HAZARDOUS LOCATION APPROVALS AND THE MARKINGS ON THE NAMEPLATE.
- EXPLOSION HAZARD: DO NOT DISCONNECT EQUIPMENT WHEN A FLAMMABLE OR COMBUSTIBLE ATMOSPHERE IS PRESENT.
- OPERATING TEMPERATURE RANGE IS 85C.
CAUTION IN HANDLING ANY POTENTIALLY HOT SURFACES

3.2 SITRANS AW210 installation to Field Device

3.2.1 Field Device Mechanical Connection

The SITRANS AW210' ½" male NPT port allows direct connection into a spare Field Device enclosure port or a junction box. The SITRANS AW210 ½" NPT will accept adapters to interface into other entry thread types; such as, M20.

WARNING

TO PREVENT THE POTENTIAL OF ALUMINUM GALLING, AN ELECTRICALLY CONDUCTIVE THREAD LUBRICANT IS RECOMMENDED TO BE APPLIED TO THE NPT THREADS PRIOR TO ASSEMBLY.

3.2.2 Antenna Positioning

The SITRANS AW210 has an internal antenna which radiates out from top cap in a 360° pattern. The SITRANS AW210 should be positioned vertically and located approximately 1 meter from any metal or conductive material which could impact the *WirelessHART*® communications. The SITRANS AW210 can placed anywhere on the current loop and does not need to be positioned directly next to the associated Field Device. This allows positioning the SITRANS AW210 in an optimal location for RF coverage.

The operating range can be reduced by interference from other nearby devices transmitting in the 2.4 GHz ISM band. These external sources of interference can prevent the establishment of *WirelessHART* connection and may result in intermittent loss of network connections causing HART network message retries. To maintain optimum antenna performance periodically remove any accumulated material from the dome; such as, dust, fiber, snow and ice. Use caution in removing any material off the resin dome so as not to damage the dome or mechanically stress the NPT threaded connection.

3.2.3 Nameplate

SITRANS AW210 nameplates contain multiple hazardous location approvals. There is a Class-Zone and ZONE installation requirement to permanently mark the nameplate for the selected installation/protection type. On each nameplate there is a box [] at the start of each line of approval markings so the nameplate can be permanently marked to denote the type of protection chosen for that specific installation. Once the SITRANS AW210 is installed and nameplate marked it should not be re-installed using any other protection type.

Class-Division installation do not have the same nameplate marking requirement as Class-Zone and ZONE. Although not required, a box [] is provided at the start of each Class-Division approval marking line to mark the nameplate.

3.2.4 Field Device Electrical Connection

The following table described the lead wire, and function of the lead wires exiting the SITRANS AW210 NPT port.

Wire Color	Wire Gage	Description
Green / Yellow	14AWG	Internal Earth Ground
Black	20AWG	Direct Power
Red	20AWG	Loop Power
White	20AWG	Return
Yellow	20AWG	HART
External Ground Screw	Accepts 10AWG [4mm ²] wire	External Earth Grounding connection

3.2.4.1 Field Wiring Functional Description

DIRECT POWER connections are between the black lead wire tied to the (+) positive source terminal and RETURN the white lead wire to the (-) negative source terminal.

LOOP POWER connections are between the red lead wire tied to the (+) positive current loop source terminal and RETURN the white lead wire tied to the (-) negative current loop terminal.

HART connections are between the yellow lead wire and the RETURN white lead wire. The SITRANS AW210 HART connections are polarity independent.

WARNING

TERMINATE UNUSED LEAD WIRES AS REQUIRED BY NATIONAL, REGIONAL AND LOCAL ELECTRICAL CODES AND PRACTICES.

3.2.5 Grounding

The SITRANS AW210 provides an external and internal grounding connection. The external grounding connection will accept up to a 10AWG [4mm²] gage wire. The grounding conductor is secured by means of a stainless steel screw, #10-32, with a captive washer. The internal ground connection is attached to the metal housing and exits the threaded ½” NPT as a 14 AWG, (GREEN/YELLOW) lead wire. This grounding connection is typical tied to the internal earth grounding terminal of the Field Device or junction box

WARNING

GROUND EQUIPMENT AS REQUIRED BY NATIONAL, REGIONAL, LOCAL ELECTRICAL CODES AND PRACTICES

3.3 Installation Options

The following sections describe several installation options for the SITRANS AW210. Please contact SIEMENS if you need help in determining how best to connect the SITRANS AW210 for your application. To contact SIEMENS Support Center call +49 (0) 180 5050 222 or visit the SIEMENS web site at <http://www.siemens.com/automation/support-request>.

3.3.1 SITRANS AW210 as a Standalone WirelessHART Router (Repeater)

The SITRANS AW210 is not attached to any Field Devices. It is strictly used at key points in a *WirelessHART* network to help with the *WirelessHART* routing of packets on behalf of other network connected devices. This is useful when it is identified in a *WirelessHART* network that additional *WirelessHART* devices located at key points will improve the overall network robustness.

In this installation option, the SITRANS AW210 is powered by a DC power source supplied by direct power. The SITRANS AW210 can be powered by an external DC power source such as; DC power supply, battery or solar panel. The DIRECT POWER specified input voltage range is 7VDC to 32VDC. For direct powered operation, connect the DC power source positive terminal to the “DIRECT POWER” black lead wire and the DC power source negative terminal to the SITRANS AW210’s “RETURN” white lead wire.

NOTE

When used in loop powered mode, the SITRANS AW210 cannot control the loop current. It is up to the user to ensure that the loop current is limited to within the operating specifications.

WARNING

THE SITRANS AW210 CAN BE DAMAGED IF THE DIRECT POWER SOURCE IS GREATER THAN 32VDC.

3.3.2 SITRANS AW210 with a 4-20mA Analog only Non-HART Field Device

The SITRANS AW210 is connected in series with 4-20mA analog output only Field Device which does not support HART. The SITRANS AW210 is capable of monitoring and reporting the analog loop current to the *WirelessHART* network.

3.3.3 SITRANS AW210 with a HART enabled Field Device

The SITRANS AW210 is connected in series with a HART Field device; such as a 4-20mA HART transmitter which also controls the loop current. The SITRANS AW210 is capable of monitoring and reporting the analog loop current to the *WirelessHART* network and will also communicate wired-HART data with the connected wired-HART sub-device. The SITRANS AW210 and the Field Device are connected in series, so the inductance has to be considered.

Connect the SITRANS AW210 and Field Device as shown in either Figure 25: Configuration #1 or Figure 26: Configuration #2 drawings

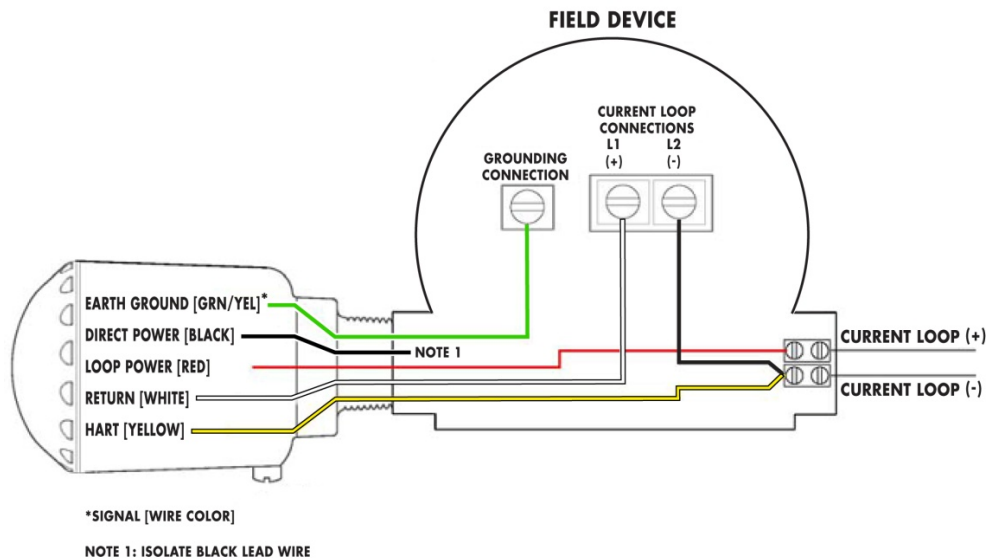

FIGURE 25: Configuration #1 SITRANS AW210 inserted into the current loop between the power source positive terminal and the FIELD DEVICE positive current loop terminal (L1).

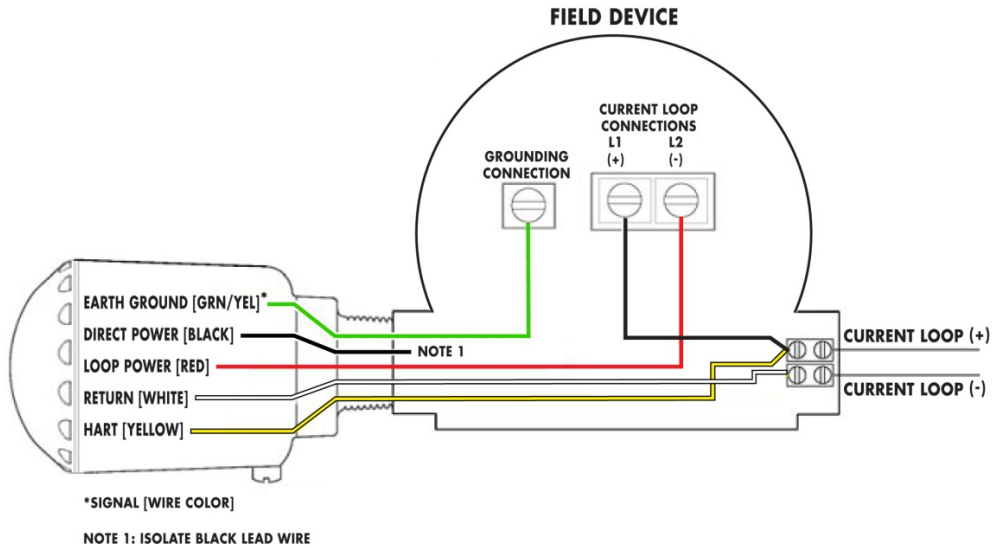

FIGURE 26: Configuration #2 SITRANS AW210 inserted into the current loop between the FIELD DEVICE negative current loop terminal (L2) and the power source negative terminal.

3.3.4 SITRANS AW210 with HART Field Devices in Multi-Drop Mode

The SITRANS AW210 can support up to a maximum of eight (8) wired HART enabled Field Devices.

These can be any combination of either input or output wired HART enabled Field Devices. The maximum number of wired-HART Field Devices that any loop can support is installation dependent. The actual number of allowed Field Devices on any loop is restricted by the insertion voltage drop of all Field Devices, wire losses and minimum Loop Power Source voltage.

3.3.5 SITRANS AW210 with HART Field Devices in LOOP POWER Multi-Drop Mode

For proper HART communication the Wired-HART network requires a 250Ω terminating resistor. When configured for LOOP POWER, the terminating resistor must be hard wired into the system as shown in Figure 27. The HART terminating resistor must be located in series with either power source terminal. The location of the HART terminating resistor will not affect the wiring shown in Figure 27. To operate in this mode the Device Description (DD). parameter FIELD DEVICE POWER CONTROL must be set to the OFF position which is the factory default setting.

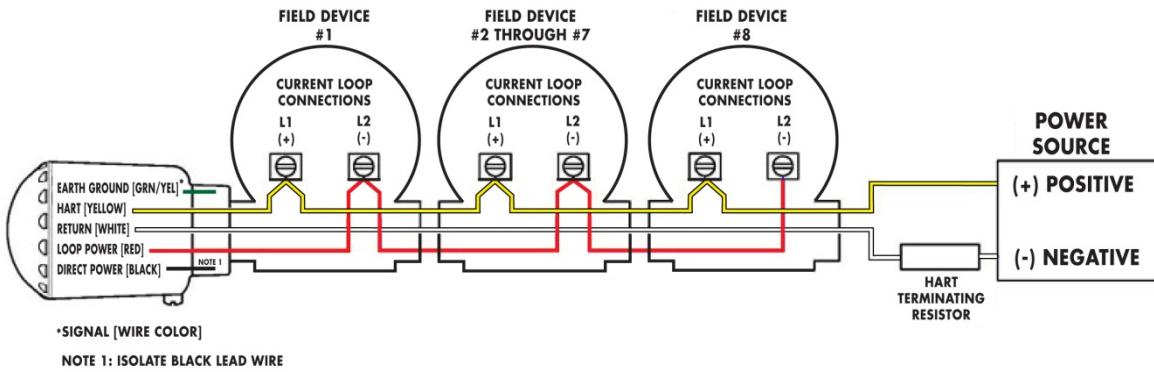

FIGURE 27: LOOP POWER Multi-Drop Configuration

Figure 27 is a simplified representation of this LOOP POWER multi-drop configuration. The DIRECT POWER, black lead wire, is not required for this configuration and is not shown. The EARTH Grounding connection is not shown.

3.3.6 SITRANS AW210 with HART Field Devices in DIRECT POWER Multi-Drop Mode

When configured for DIRECT POWER, the HART terminating resistor requirement can be met by either by physically wiring a resistor into the system or by using the SITRANS AW210 internal terminating resistor. The SITRANS AW210 provides a switchable resistor connecting a 250 Ohm resistor between the HART, yellow lead wire, and RETURN white lead wire. To use the SITRANS AW210 internal resistor the operator must properly configure the Device Description (DD). The operator must configure the DD parameter FIELD DEVICE POWER CONTROL to the – ON setting. Refer to section 2 Configuration, Detailed Setting, Field Device Power Control section for the description and use of the Device.

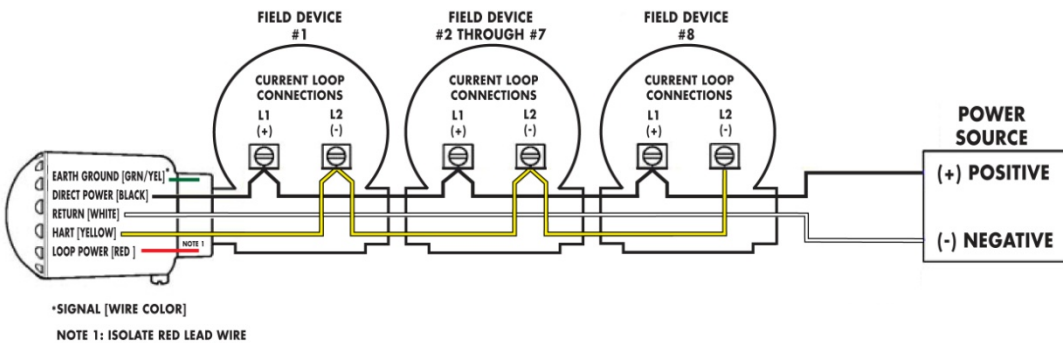

FIGURE 28: DIRECT POWER Multi-Drop Configuration – FIELD DEVICE CONTROL – ON position

Figure 28 is a simplified schematic representation of this DIRECT POWER multi-drop configuration with FIELD DEVICE CONTROL is set to the ON position. The LOOP POWER, red lead wire, is not required for this configuration and is not shown. The EARTH Grounding connection is not shown.

3.3.7 SITRANS AW210 with a 4-20mA Field Device with Battery Powered Operation

In this installation option, the SITRANS AW210 is connected in series with an either an analog only or HART enabled Field Device and can be configured for either Loop Power or DIRECT POWER.

An external battery or other DC power source such as solar is used to power the SITRANS AW210 and Field Device.

Configured for Loop power, the SITRANS AW210 and Field Device are continuously powered and is not the optimum energy management configuration for battery operation. When configured for DIRECT Power, the SITRANS AW210 can control the power to the Field Device which will result in optimum energy management for battery operation.

To manage the battery power the SITRANS AW210 must be configured to use the FIELD DEVICE POWER CONTROL feature which allows the user to specify the battery powered “on” and “off” time. This software controlled function is enabled by means of the HART Device Description (DD). The user configures the FIELD DEVICE POWER “on” time as required by the application and or as required by the Field Device to operate properly.

The SITRANS AW210 has internal circuitry to monitor battery consumption when an external battery is used for the Direct Power input. Since the battery is external, there are many possible battery options that the user could employ; therefore, the SITRANS AW210 battery measurement circuitry is very flexible and configurable.

There are two major variables measured to determine the remaining battery life – the battery voltage and the battery coulomb discharge rate. Both of these measurements are continuously being performed by the SITRANS AW210 on the battery, and both of these measurements are used to determine the remaining battery life and the power status

4 Detailed Settings and Parameter Definitions

4.1 HART Dynamic Variables

The SITRANS AW210 appears as a HART device on both the wired-HART and *WirelessHART* networks, and supports four HART dynamic variables. These can be read using standard HART commands and are displayed in the SITRANS AW210 DD.

HART Variable	<i>WirelessHART</i> Packets per Second
Primary Variable (PV)	Loop Current (mA)
Secondary Variable (SV)	Direct Power Voltage (V)
Tertiary Variable (TV)	Internal Temperature (C)
Quaternary Variable (QV)	Storage Voltage (V) (Internal to the SITRANS AW210)

4.1.1 Configure Power Mode (method)

The Configure Power Mode DD Method guides the user through the selection of the proper power mode settings for their configuration.

4.1.1.1 SITRANS AW210 Power

By Default, the SITRANS AW210 is configured for loop powered operation with a 1.0V insertion voltage drop. Through the DD, the power setting can be changed to set the insertion voltage drop to 1.0V, 1.5V, 2.0V or 2.5V. The power mode setting can also be set to several different direct power modes

Adapter Power Setting	WirelessHART Packets per Second
Loop Powered - 1.0 V	4.25
Loop Powered – 1.5 V	12.65
Loop Powered – 2.0V	19.66
Loop Powered – 2.5V	26.66
Direct Powered – Max Bandwidth	101.40
Direct Powered – Power Save	26.66
Direct Powered - Battery	26.66

NOTE

The value shown in WirelessHART Packets per second column is the value reported back in HART Command 777.

Loop Powered

This allows for different StepVolt™ settings to be selected when operating in a loop powered mode.

Direct Powered – Max Bandwidth

This allows for the maximum *WirelessHART* bandwidth possible and assumes that the direct power source can supply maximum power.

Direct Powered – Power Save

This assumes that the direct power source is limited and will limit the amount of *WirelessHART* packets to a small amount to conserve power

Direct Powered – External Battery

This assumes that the direct power source is an external battery, and this will enable the built-in battery management functionality (battery life calculations, battery alerts) in the SITRANS AW210.

NOTES

- The SITRANS AW210 will power up and begin to operate with any valid power installation, regardless of what the SITRANS AW210's Power setting is configured as. This allows for the user to change this setting even if it is configured incorrectly, however any changes to this should be performed before the SITRANS AW210 has joined the WirelessHART network. If this power setting set different than how the SITRANS AW210 is actually powered (such as a Direct Powered setting is selected but the unit is actually loop powered), the system operation is not guaranteed and it is possible that the SITRANS AW210 will reset due to insufficient power once connected to the WirelessHART network.
- The unit can be both Direct Powered and wired in series with the loop. When configured in any of the Direct Powered modes, there will be an insertion voltage drop of 1.0V if the SITRANS AW210 is also wired in series with the loop.

4.1.1.2 Field Device Power Control

When used in a direct power configuration, the SITRANS AW210 can activate a switchable terminating resistor between the HART and the RETURN signal wires. This can eliminate the need for an external terminating resistor in some installation and also allows for the field device power to be switchable and controlled automatically by the SITRANS AW210.

The parameter "Field Device Power Control" can be set to three different states: Off, On, or Switching.

Off: The Field Device Power Control switch is never connected

On: The Field Device Power Control switch is always connected

Switching: The SITRANS AW210 will automatically control the operation of the Field Device Power Control switch.

4.1.1.3 Field Device Cutoff Enable

This option allows the SITRANS AW210 to cutoff power to the Field Devices when the direct power input drops below the voltage set in the Field Device Cutoff Voltage parameter. To use the cutoff, the Field Device Power control must set to either On or Switching. When this parameter is disabled, this cutoff will not occur and the Field Device Cutoff Voltage parameter is not used.

4.1.1.4 Field Device Cutoff Voltage

When enabled, defines the direct power voltage at which the Field Device Cutoff will occur.. There is a built-in 0.5V hysteresis in this to bring the SITRANS AW210 out of the Field Device Cutoff mode.

4.1.1.5 Field Device Power Control – Switching Mode

When the SITRANS AW210 is used in the “Field Device Power Control Switching” mode, the SITRANS AW210 will control this switch to power on and off HART Field Devices as needed by the network operation. This is useful when running off a limited power source, such as an external battery or solar cell, and can be used to power off the HART field devices between measurements.

When used in combination with Burst mode, the SITRANS AW210 will schedule measurements from the HART devices connected, and will turn on the loop when a scheduled measurement is needed. After all the measurements have been read from the connected HART devices, the SITRANS AW210 will

remove power from the field devices by turning off the “Field Device Power Control” switch.

For this mode to work properly, the user needs to determine and configure the “Power On Time” parameter for the connected wired HART field devices.

Field Device Turn On Time:

The time in seconds that a HART field device needs to be powered on in order to obtain an accurate measurement.

NOTES

- Improper selection of the “Power On Time” parameter can lead to a field device reporting measurements outside of the published tolerances for the device. Consult the field device documentation or contact the field device vendor to determine this information.
- The “Power On Time” is different for every Field Device. If not specified in the Field Device data sheet contact the manufacturer of the Field Device for this parameter.
- Incorrect measurement reading from the Field Device may result if “Power On Time” parameter is not set properly. The Field Device may not have adequate time to power up, initialize and respond with a correct measurement value prior to power being removed.

Field Device Idle Time:

The time in seconds that the field device will remain powered after an unscheduled event. This event could be a HART query over the *Wireless*HART handheld or detection of another HART master trying to communicate (such as a wired HART handheld). This parameter prevents the SITRANS AW210 from powering off a field device when some other master is attempting communication with the field device. This parameter can generally be left at the default of 60 seconds.

4.1.1.6 Field Device On Estimated Percentage:

This is the estimated time that the field device will be powered during normal operation. This is a calculation based upon the Field Device Power On Time and the Burst mode settings of the SITRANS AW210. The lower this value is, the less amount of power will be used.

4.1.1.7 External Battery Settings

The SITRANS AW210 has internal circuitry to monitor battery consumption when an external battery is used for the Direct Power input. Since the battery is external, there are many possible battery options that the user could employ, therefore the SITRANS AW210 battery measurement circuitry is very flexible and configurable.

There are two major variables measured to determine the remaining battery life – the battery voltage and the battery coulomb discharge rate. Both of these measurements are continuously being performed by the SITRANS AW210 on the battery, and both of these measurements are used to determine the remaining battery life and the power status

4.1.2 Power Status

WirelessHART defines three power status levels for battery powered devices.

Power Status: Nominal - The power for the device is operating correctly

Power Status: Low – The power source for the device has under 25 days of life remaining. The power source should be exchanged when the low indication is set.

Power Status: Critical – The power source for the device is critically low and loss of power will happen in the immediate future.

4.1.2.1 Battery Life Remaining

The amount of days of battery life that the system is expected to be able to run, based on the average battery consumption rate (from the previous one hour of operation).

4.1.2.2 Battery Capacity

This is the capacity of the battery in milliamp-Hours, and is used by the coulomb counter algorithm to determine the remaining battery life in days.

4.1.2.3 Battery Low Voltage

This is the battery voltage value below which the power status will be set to “Low” and the battery life remaining will be 25 days or less. This is an independent failsafe check for the coulomb counter remaining life calculation.

4.1.2.4 Battery Critical Voltage

This is the battery voltage value below which the power status will be set to “Critical” and the battery life remaining will be set to 0 days. This is an independent failsafe check for the coulomb counter remaining life calculation.

4.1.3 Join Device to Network (method)

The Join Device to Network DD Method guides the user through entering in the *WirelessHART* network ID and join key, and starting the *WirelessHART* join procedure.

4.1.4 Network ID

The Network ID is the ID of the *WirelessHART* Network to join.

4.1.5 Join Key

The Join Key is a 32 character hexadecimal password (broken into four 8 character blocks) which is used to get access to the *WirelessHART* network.

4.1.6 Radio Output Power

The transmit power of the SITRANS AW210's radio. Can be set to either 0dBm or +10dBm.

4.1.6.1 HART Polling Address

This is the HART polling address that is used to communicate to the SITRANS AW210 on the wired-HART interface using a HART capable host (such as a HART communicator or PC with HART modem).

By Default, the SITRANS AW210 is at HART polling address 15. Through the DD, the polling address can be set to any value between 0 and 63.

4.1.6.2 HART Master Mode

This is the HART Master mode used by the SITRANS AW210 when it is communicating as a HART master with wired-HART devices.

By Default, the SITRANS AW210 is configured as a HART primary master. Through the DD, the master mode can be changed to be either a HART secondary or primary master.

4.1.6.3 RT Retry Count

This is the amount of retries the SITRANS AW210 will attempt when communicating as a HART master to wired-HART devices.

By Default, the SITRANS AW210 is configured to use 3 retries. Through the DD, the retry count can be set to 2, 3, 4 or 5.

4.1.6.4 HART Number of Response Preambles

This is the amount of preambles the SITRANS AW210 will use when responding to HART commands sent by a HART master (such as a HART communicator or PC with HART modem) on the wired-HART connection.

By Default, the SITRANS AW210 is configured to use 5 preambles. Through the DD, the response preamble count can be set between 5 – 20 preambles

4.1.6.5 Write Protect

This setting allows the configuration inside of the SITRANS AW210 to be write protected. The write protect setting is controlled through the DD.

By Default, the SITRANS AW210 is configured to have write protect disabled. Through the DD, the write protect setting can be enabled or disabled.

4.1.6.6 Sub-Device Time Synchronization

If a HART 7 or greater sub-device is detected and it supports a real-time clock, the SITRANS AW210 can synchronize the sub-device time with the *WirelessHART* Network time if this setting is enabled. If the sub-device does not support a real-time clock, this setting has no effect. This synchronization will be performed when the SITRANS AW210 joins the *WirelessHART* network and then once per day.

4.1.6.7 Sub-Device Scan on Power-up

When Sub-Device Scan on Power-up is enabled, the SITRANS AW210 will scan the 4-20mA loop for attached HART devices on power-up or when the SITRANS AW210 is reset. These will be added to the list of supported sub-devices for the SITRANS AW210 and will be communicated with the *WirelessHART* gateway.

Within the DD, Automatic Sub-device detection can be enabled or disabled. It is highly recommended that this mode always be left **enabled**.

If this mode is disabled, the host must support scanning for sub-devices in order for any sub-device to be detected or you must manually execute the Scan for Sub-Devices method. The list of sub-devices is not retained through a power-cycle or reset of the SITRANS AW210, so the host would need to detect this and rescan for sub-devices.

NOTES

- The sub-device scan is only performed after a power-up or reset of the SITRANS AW210. If wired-HART devices are added to the loop after the SITRANS AW210 is powered, execute the Scan for Sub-Devices method or reset the SITRANS AW210 to detect them
- The SITRANS AW210 can support a maximum of eight sub-devices. If more than eight wired-HART devices are detected, only the first eight devices will be used.

4.1.6.8 Scan Start Address

This is the first HART polling address that will be used when a scan for Sub-devices is performed.

4.1.6.9 Scan Stop Address

This is the last HART polling address that will be used when a scan for Sub-devices is performed.

4.1.7 Scan for Devices (method)

The Scan for Devices DD method will perform a scan for sub-devices connected to the SITRANS AW210, across the HART polling addresses defined.

This method allows for the existing sub-device list to be either retained or erased prior to the new scan.

4.1.8 4-20 mA Settings

The SITRANS AW210 has the ability to measure the loop current from field devices when wired in a loop powered mode. The SITRANS AW210 can be connected to analog only 4-20 mA field devices (with no HART capability) and report this loop current value to the *WirelessHART* Network.

The SITRANS AW210 can convert the 4-20 mA value read from a field device into engineering units that are reported to the *WirelessHART* network as the Primary Variable (PV) of the SITRANS AW210. The SITRANS AW210 can also implement a lookup table to linearize this conversion.

4.1.9 PV Units

The engineering units that the SITRANS AW210 PV will be reported as.

4.1.9.1 PV Linearization Mode

This can be set to Linear or Special Curve. If set to Linear, the PV Upper Range Value and Lower Range Value will be the values in engineering units that correspond to the 4 and 20 mA points, and a basic linear calculation will be performed to convert the measured loop current to engineering units.

If this is set to Special Curve, the user can enter in data pairs (a loop current value to a engineering unit value) into the PV Linearization Table. The table needs to have at least two data pairs and can have up to 32 pairs. When converting the loop current to engineering units, the SITRANS AW210 will use this lookup table to perform a more accurate linearization.

4.1.9.2 PV Damping Value

This is the damping value in seconds that will be applied to the PV measurement.

4.1.9.3 PV Upper Range Value (20 mA)

When the Linearization Mode is set to Linear, this is the value in engineering units that correspond to the loop current at 20 mA.

4.1.9.4 PV Lower Range Value (4 mA)

When the Linearization Mode is set to Linear, this is the value in engineering units that correspond to the loop current at 4 mA.

4.1.9.5 Upper Fault Current

This is the value of the loop current in milliamps that above which will set a HART loop current alarm.

4.1.9.6 Upper Limit of Proportional Range

This is the value of the loop current in milliamps that above which will set a HART loop current warning.

4.1.9.7 Lower Limit of Proportional Range

This is the value of the loop current in milliamps that below which will set a HART loop current warning.

4.1.9.8 Lower Fault Current

This is the value of the loop current in milliamps that below which will set a HART loop current error.

4.2 Automatic Burst Mode Configuration

When Automatic Burst Mode Configuration is enabled, the SITRANS AW210 will automatically configure burst messages for SITRANS AW210 itself and all of the connected sub-devices.

The Automatic Burst Mode Configuration setting can be set from within the DD, and allows the user to select several different fixed update rates (1 second, 2 seconds, 4 seconds, 8 seconds, 16 seconds, 32 seconds, 1 minute, 2 minutes, 5 minutes, 10 minutes, 30 minutes, 60 minutes) at which all of the burst messages will be published to the *WirelessHART* gateway. If this mode is disabled, burst mode can be configured manually using the DD.

NOTE

If the Automatic Burst Mode Configuration setting is set, this will override any manual configuration of the burst mode settings. If any manual burst mode settings are configured, Automatic Burst Mode will be automatically turned off.

4.3 Factory Reset

Executing the factory reset will reset the following SITRANS AW210 parameters and then cause the SITRANS AW210 to reset: The software controlled factory reset can be initiated by means of the HART Device Description (DD).

A password will be requested as part of the this reset process: password = siemens.

SITRANS AW210 Parameter	Default Value
Adapter Power Mode	Loop Powered – 1.0 V
Field Device Power Control	Off
Field Device Turn On Time	10.0 seconds
Field Device Idle Time	60.0 seconds
Field Device Cutoff Enable	Disabled
Field Device Cutoff Voltage	18.0 V
Battery Low Voltage	20.0 V
Battery Critical Voltage	18.0 V
Battery Capacity	10000 mAh
WirelessHART Network ID	1229
WirelessHART Join Key	44555354 4E455457 4F524B53 524F434B (hex)
WirelessHART Join Mode	Don't Join
Radio Output Power	+10dBm
Over the Air Upgrade	Enabled
HART Master Mode	Primary Master
HART Retry Count	3
HART Polling Address	15
HART Scan On Power Up	Enabled
HART Polling Scan Start Address	0
HART Polling Scan Stop Address	15
HART Sub-device Time Sync	Enabled
HART Response Preambles	5
Write Protect	Off
HART Lock State	Cleared
Electronics Temperature Units	degC
PV Linearization Mode	Linear
PV Units	mA
PV Damping Value	0.0 secs
PV Upper Range Value (20mA)	20.0 mA
PV Lower Range Value (4 mA)	4.0 mA
PV Upper Limit of Prop Range	20.5 mA
PV Lower Limit of Prop Range	3.8 mA
Upper Fault Current	21.0 mA
Lower Fault Current	3.6 mA

4.4 ALERTS

The SITRANS AW210 will detect and log system events to alert the user when something has occurred that could effects system operation.

Note: All Alerts are also mapped into HART Command 48 status bits.

4.4.1 Active Alerts

The condition that caused the alert is still present. Active alerts cannot be cleared - corrective action must be taken to eliminate the alert, such as modifying some external source of the event (such as the power supply) or by changing an incorrect setting in the SITRANS AW210.

4.4.2 Alert History

The condition that caused the alert is no longer present, or the alert is a onetime event. The start timestamp indicates when this alert first occurred and the stop timestamp indicates when the alert stopped (or the last time the alert was detected).

4.4.3 Clear Alert (method)

This will clear the current alert.

4.4.4 Clear All Alerts (method)

This will clear the entire alert history for the SITRANS AW210.

4.4.5 ALERT – Direct Power Out of Range

Description:

The SITRANS AW210 is configured for Direct Power Mode and the voltage on the Direct Power input is outside of the allowable operating range for the SITRANS AW210.

Corrective Action:

Correct the Direct Power source supply.

Timestamps:

Start: Set when the alert is first detected.

Stop: Set when the alert state goes away.

4.4.6 ALERT – Loop Power Out of Range

Description:

The SITRANS AW210 is configured for Loop Power Mode and the current on the loop power connection is outside of the allowable operating range for the SITRANS AW210.

Corrective Action:

Correct the loop power supply.

Timestamps:

Start: Set when the alert is first detected.

Stop: Set when the alert state goes away.

4.4.7 ALERT – Temperature Out of Range

Description:

The electronics temperature inside of the SITRANS AW210 is outside of the allowable operating range for the SITRANS AW210.

Corrective Action:

Ensure that the SITRANS AW210 is installed in an environment with its environmental operating range.

Timestamps:

Start: Set when the alert is first detected.

Stop: Set when the alert state goes away.

4.4.8 ALERT – Power Mode Miss configured

Description:

The power mode detected on the inputs for the SITRANS AW210 currently does not match the power mode configuration settings.

Corrective Action:

Check the Adapter Power mode setting to ensure it is the same as how the SITRANS AW210 is wired.

Timestamps:

Start: Set when the alert is first detected.

Stop: Set when the alert state goes away.

4.4.9 ALERT – Watchdog Reset

Description:

The microprocessor inside of the SITRANS AW210 has experienced a watchdog reset event.

Corrective Action:

Clear the alert – report the event to SIEMENS.

Timestamps:

Start: Set when the alert is first detected.

Stop: Not Used

4.4.10 ALERT – Stack Overflow

Description:

The microprocessor inside of the SITRANS AW210 has experienced a stack overflow event.

Corrective Action:

Clear the alert – report the event to SIEMENS.

Timestamps:

Start: Set when the alert is first detected.
Stop: Not Used

4.4.11 ALERT – Duplicate HART Master Detected

Description:

A HART Master has been detected that is configured as the same Master type as the SITRANS AW210. This will prevent the SITRANS AW210 from communicating with connected Sub-Devices while the other HART master is present.

Corrective Action:

If there is another HART Master present, ensure that it and the SITRANS AW210 are configured for different HART Master types. When using a HART Handheld, ensure that it is not set for the same Master Type as the SITRANS AW210.

Timestamps:

Start: Set the first time the duplicate HART Master was detected.
Stop: Set the last time the duplicate HART Master was detected.

4.4.12 ALERT – HART Devices Count Exceeded

Description:

A HART Master has been detected that is configured as the same Master type as the SITRANS AW210. This will prevent the SITRANS AW210 from communicating with connected Sub-Devices while the other HART master is present.

Corrective Action:

If there is another HART Master present, ensure that it and the SITRANS AW210 are configured for different HART Master types. When using a HART Handheld, ensure that it is not set for the same Master Type as the SITRANS AW210

Timestamps:

Start: Set the first time that too many HART devices were detected
Stop: Same as the start time

4.4.13 ALERT – HART Sub-Device Lost

Description:

A Sub-device connected to the SITRANS AW210 has stopped communicating and has been dropped from the sub-device list.

Corrective Action:

If the Sub-device was removed intentionally, clear the alert. Else, check the connection / power to the sub-device and verify communications with a wired-HART handheld or PC.

Timestamps:

Start: Set when the sub-device was lost

Stop: Same as the start time

4.4.14 ALERT – Burst Packets are Being Dropped

Description:

One or more burst packets have been dropped from the SITRANS AW210 to the *WirelessHART* Network.

Corrective Action:

Check to ensure that the *WirelessHART* Network has granted the requested bandwidth for the burst settings. If not, either adjust the *WirelessHART* network settings or adjust the burst times for the SITRANS AW210.

If the burst messages being dropped are for a wired Sub-device, ensure that there are no other HART masters on the connection, as these can cause burst message delays.

Timestamps:

Start: Set when the first HART Burst packet was dropped

Stop: Set when the last HART Burst packet was dropped

4.4.15 ALERT – Field Device Power Control

Description:

The field device power control mode is set to Switching, however the burst / event configuration will keep the device always powered on.

Corrective Action:

If the Field Device Power Control Mode – Switching is not required, change this option.

Else, reduce the burst times for the wired Sub-devices such that the system will switch the power to the devices. Check the “Field Device Estimate On Percentage” for an estimated duty cycle that the Field Devices will be powered on for. This alert will be set whenever this value is 100% and the Field Device Power Control Mode is set to Switching.

Timestamps:

Start: Set when the Field Device Power Control issue is first detected

Stop: Set when the Field Device Power control issue is corrected

4.4.16 ALERT – Wireless Capacity Denied

Description:

The *WirelessHART* network has denied a request for *Wireless* bandwidth.

Corrective Action:

Check the burst mode settings for the device and reduce the requested bandwidth.

Timestamps:

Start: Set when the *WirelessHART* Network first denies bandwidth

Stop: Set when the *WirelessHART* Network grants bandwidth

4.4.17 ALERT – Burst Message Configuration Issue

Description:

A burst message is configured to a command that is not supported by the selected Sub-device

Corrective Action:

Change the command number of the burst message to a command that is supported by the Sub-device.

Timestamps:

Start: Set when the configuration issue is first detected

Stop: Set when the configuration issue is corrected

4.4.18 ALERT – Wired Device in Burst Mode

Description:

A wired device is configured for wired burst mode, which may conflict with the SITRANS AW210 burst settings.

Corrective Action:

Change the configuration of the wired device to not be in wired burst mode.

Timestamps:

Start: Set when the wired burst mode message is first detected

Stop: Set when the last wired burst mode message was detected

4.4.19 ALERT – SITRANS AW210 Failed to Join the Network

Description:

The SITRANS AW210 has failed to join the *WirelessHART* Network.

Corrective Action:

Check the Network ID and Join key set on both the SITRANS AW210 and the *WirelessHART* Network.

Timestamps:

Start: Set when the *WirelessHART* Network Join procedure failed

Stop: Set when the *WirelessHART* Network Join procedure succeeds

4.4.20 ALERT – Radio Malfunction

Description:

The radio module inside the SITRANS AW210 is malfunctioning.

Corrective Action:

Report this issue to SIEMENS.

Timestamps:

Start: Set when the radio malfunction was detected

Stop: Set when the radio malfunction clears

4.4.21 ALERT – Variable Simulation

Description:

One or more of the device variables are being simulated.

Corrective Action:

Check the simulation settings for the variables.

Timestamps:

Start: Set when one of the device variables is put into simulation mode

Stop: Set when all of the devices variables are put into normal mode

4.4.22 ALERT – Field Device Cutoff Occurred

Description:

The Field Device Cutoff function is enabled and the direct power voltage dropped below this setting, causing the Field Device power to be cutoff.

Corrective Action:

Ensure the direct power voltage is a high enough voltage.

Timestamps:

Start: Set when the field device cutoff occurs

Stop: Set when the field device cutoff ends (by having a direct power voltage high enough)

4.4.23 ALERT – Low Battery

Description:

The SITRANS AW210 is configured to use an external battery, and the battery voltage has dropped below the Battery Low Voltage parameter, or the calculated remaining battery life is under 25 days remaining.

Corrective Action:

Replace the external battery

Timestamps:

Start: Set when the external battery voltage or remaining life calculation passes the low battery threshold.

Stop: Set when the external battery voltage is above the low battery threshold or the user clears the battery counters.

4.5 HART Device Description (DD) TREE

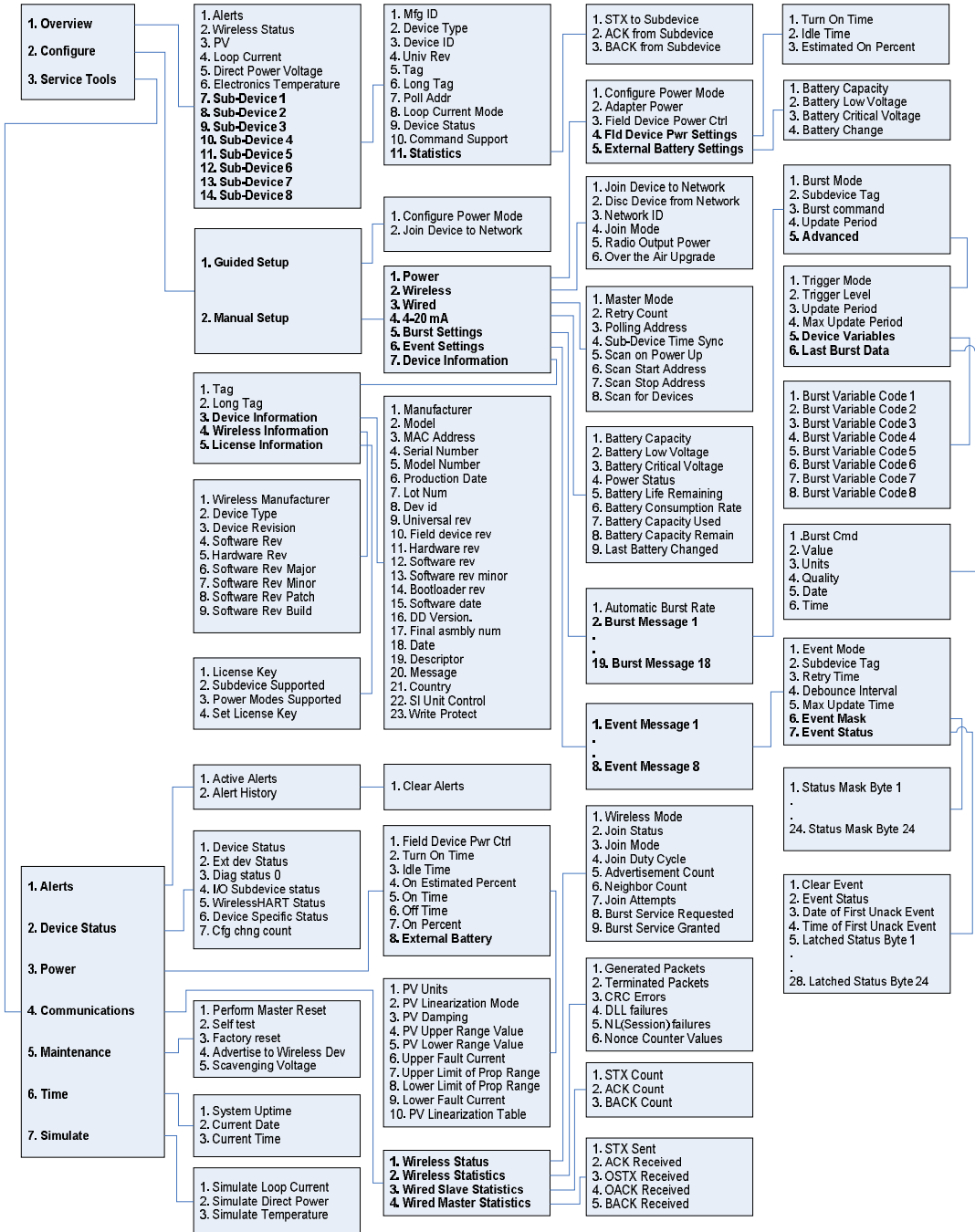

5 Maintenance

The SITRANS AW210 has no scheduled maintenance requirements and has no serviceable parts.

As required, to maintain optimum antenna performance, periodically removal any accumulated material from the dome; such as, dust, fiber, snow and ice. Use caution in removing any material off the resin dome so as not to damage the dome or mechanically stress the NPT threaded connection. No solvents should used in the removal of any accumulated material.

6 Commissioning

Upon power-up of the SITRANS AW210 in the field, the SITRANS AW210 will attempt to identify any connected HART devices (if the Automatic Sub-device Detection option is enabled).

Operation can be verified through the use of the SITRANS AW210 HART DD via a HART communicator or PC with HART Modem. Operation can also be verified via the *WirelessHART* Gateway interface.

With the DD, verify that the correct HART sub-device(s) have been detected by the SITRANS AW210. Also verify that the SITRANS AW210 is attempting to join or has joined the *WirelessHART* Network.

With the *WirelessHART* Gateway, verify that the SITRANS AW210 has been detected and that all of the connected wired-HART sub-devices have been detected.

NOTES

- The SITRANS AW210 should be installed after the WirelessHART gateway has been installed and is verified to be working.
- NOTE: To speed the WirelessHART joining procedure, it is recommended to turn on the Active Advertising mode of the WirelessHART Gateway whenever new devices are added

7 Troubleshooting

Does Not Detect Wired-HART Sub-Devices

Verify the SITRANS AW210 wiring for the mode of operation that is being used.

Verify HART communication with the SITRANS AW210 with a HART Communicator or PC with HART modem. Once this is working, without moving the HART connections on the modem, verify HART operation with the HART sub-device.

If the HART Communicator is able to communicate with both the sub-device and the SITRANS AW210, the SITRANS AW210 should be able to communicate with the sub-device.

Cannot Connect to the WirelessHART Network

Check the *WirelessHART* Gateway for the correct Network ID and Network Join Keys.

Using the SITRANS AW210 HART DD, both of these settings are entered in with a decimal format. It is possible that either of these settings are shown in a hexadecimal format on the *WirelessHART* Gateway. If so, convert these values into a decimal format before entering them into the SITRANS AW210.

Resetting the SITRANS AW210

Soft Reset – Via DD

Through the DD, a reset command can be performed to reset the SITRANS AW210.

Soft Reset – Via Power connections

Disconnect all power sources to the SITRANS AW210 for 5 seconds. Reapply power and the SITRANS AW210 reset

Hard Reset

Since the SITRANS AW210 has a large internal energy store, to perform a true Hard Reset (complete power loss), disconnect all power sources to the SITRANS AW210 for 5 minutes. Then re-apply power to the SITRANS AW210. Resets to factory default setting

8 Product Order Information

PRODUCED BY

MACTek® Corporation
Gates Mills, Ohio 44044, USA

ORDER INFORMATION

Order Number: 7MP3111-**aAbc0**-0AA0

Where

a- denotes number of multi-drop devices supported

1- 2 devices

2 - 8 devices

b- denotes protection type

B - Intrinsically Safe

C - Explosionproof-Flameproof

c- denotes housing material

0 - Aluminum

Order Number: 7MP3111-1AB00-0AA0

Product Description:

2 multi-drop devices supported, Intrinsically Safe, Aluminum Housing

Order Number: 7MP3111-2AB00-0AA0

Product Description:

8 multi-drop devices supported, Intrinsically Safe, Aluminum Housing

Order Number: 7MP3111-1AC00-0AA0

Product Description:

2 multi-drop devices supported, Explosionproof-Flameproof, Aluminum Housing

Order Number : 7MP3111-2AC00-0AA0

Product Description:

8 multi-drop devices supported, Explosionproof-Flameproof, Aluminum Housing

9 Specifications

System	
Platform	WirelessHART capable network
Compliance	Fully compliant HART 7.1 device, complies with HART 7.1 <i>Wireless</i> Adapter device type. Backward compatible to HART 5 devices
HART Sub-Devices	Supports up to 8 wired HART sub-devices (maximum number depends on multi-drop installation)
Radio	
Range	235 meters outdoors, open air (nominal)
Operating Frequency Modulation , # of Channels	2.4 GHz to 2.4835GHz , 16 Channel frequency hopping
RF Output Power	10dBm (10mW)
Electrical	
Series Loop Voltage Drop	1.0VDC – 2.5VDC, user settable in 0.5VDC steps.
Series Loop Operating Current	3.2 ma to 25 mA DC operating; Protected against overvoltage, over-current, and reverse connections.
Ext Power Operating Voltage	+7VDC to +32VDC, Reverse voltage protection
Ext Power Operating Current	Typical < 1mA, Max: 20 mA
HART Output Level	Fully HART compliant trapezoidal wave @ 1200/2200 Hz
Multi-Drop (Direct Power)	32mA DC maximum, 8 devices at 4mA DC
Multi-Drop (Loop Power)	24mA DC maximum, 6 devices at 4mA DC
Loop Current Monitoring and Accuracy	4.0mA to 20mA DC 1% FSR: -40C to +85C
Environmental	
Operating Temperature Hazardous Location	Temperature Class T5 -40°C to +85°C Temperature Class T6 -40°C to +75°C
Operating Temperature, General Purpose, Ordinary Location	-40C° to +85°C
Humidity: relative	100%
Storage Temperature	-40° C to +85°C
Physical Dimensions	
Dimensions	Height : 100 mm (3.9") , Diameter : 60.8 mm (2.4") , Weight : 0.46 kg (1lbs)
Enclosure	Housing: Aluminum alloy, RoHS complaint corrosion coating polyurethane enamel paint Dome: propriety resin
Connection	One, Male ½" NPT
Field Termination	5 lead wires x 600mm (24") long, exiting from male ½" NPT opening 5 leads: 4 signal and 1 internal earth grounding connection Enclosure: 1 external earth grounding screw: SS #10-32 with captive washer

10 Mechanical

10.1.1 Dimensional Drawing



Dimensions are in inches [millimeters]

10.1.2 Enclosure

The SITRANS AW210 enclosure is a die cast, low copper, aluminum alloy housing is protected by a RoHS complaint corrosion coating and polyurethane enamel paint.

As with any aluminum threads, to prevent the potential of aluminum galling, an electrically conductive thread lubricant is recommended to be applied to the SITRANS AW210 NPT threads prior to assembly.

Refer to Section 11, Certifications for the enclosure ratings.

11 Certifications

11.1 European Directive Information

The EU Declaration of Conformity for this product can be found on the SIEMENS web site: www.siemens.com/wirelesshart.

ATEX Directive (94/9/EC)

This product compiles with the ATEX Directive

Electro Magnetic Compatibility Directive (EMC) (2004/108/EC)

This product compiles with the EMC Directive

Radio and Telecommunications Terminal Equipment Directive (R&TTE) (1995//EC)

This product compiles with the R&TTE Directive

Declaration of Conformity

The Declaration of Conformity can be obtained by either contacting the SIEMENS or visiting the web site at www.siemens.com/wirelesshart.

11.2 Telecommunication Compliance

All *Wireless* devices require certifications of compliance to ensure that they meet applicable regulations regarding to the RF spectrum. This type of certification is required by most countries. SIEMENS is seeking certification in the countries of use as required by national regulations to provide a fully compliant product.

11.2.1 FCC & IC

This device complies with FCC rules, Part 15 of CFR 47 and IC specification RSS-210. The operation of this device is subject to the following conditions of use: This device will not cause harmful interference. This device must accept any interference received, including interference that may cause undesirable operation.

To ensure FCC and IC compliance, this device is to be used as configured from the factory. No modifications to either the radio or antenna are allowed.

11.2.2 R&TTE

Radio and Telecommunications Terminal Equipment Directive (R&TTE) (1995//EC)

This product compiles with the R&TTE Directive.

11.3 Ordinary Locations Certifications

As requirement of the R&TTE Directive and Hazardous Location approval process this product has been examined and tested to meet basic electrical, mechanical and fire protection requirements of EN61010-1 and ANSI/ISA 61010-1.

11.4 Hazardous Location Certificates

Issuing approval agencies; FM Approvals for US, Canada and IEC.
FM Approvals Ltd for ATEX .

11.4.1 North America Certificates

11.4.1.1 United States Certificates

CLASS-DIVISION: GAS, DUST and FIBER

Intrinsically Safe for Class I, II, III, - Division 1, Groups A,B,C,D,E,F,G

Non-Incendive for Class I, Division 2, Group A,B,C,D

Suitable for Use Class II, III, Division 2 Group E,F,G

Intrinsically Safe and Suitable for use when installed per SIEMENS Drawing AT1101030C.

Explosionproof for Class I, II, III, - Division 1, Groups A,B,C,D,E,F,G

DUST IGNITIONPROOF for Class II, III, Division 1 Group E,F,G

FACTORY SEALED, CONDUIT SEAL NOT REQUIRED

ZONE MARKINGS

Intrinsically Safe (GAS) : II 1 G

Class 1, Zone 0, AEx ia IIC Ga T5, T6

Intrinsically Safe (DUST) : II 1 D

Zone 20, AEx iaD 20 IP68 T95°C

Non-Sparking (GAS), Encapsulated (GAS): II 3 G

Class 1, Zone 2, AEx nA nC IIC T5, T6

Flameproof (GAS) : II 2 G

Class 1, Zone 1, AEx d IIC T5, T6 Gb

Flameproof (DUST) : II 2 D

Zone 21, AEx tb IIIC T95°C

TEMPERATURE CLASS

T5: -40°C to +85°C, T6: -40°C to +75°C

ENCLOSURE RATING

TYPE 6P, IP68 1.8m 24hr

ENTITY PARAMETERS

Ui= 30V, Ii=120mA, Pi=0.9W, Ci= 0uFD, Li= 596uH

CLASS 1, Zone 0 : Special Condition of Use

This product enclosure contains aluminum and is considered to constitute a potential risk of ignition by impact or friction. Care must be taken into account during installation and use to prevent impact and friction.

11.4.1 United States continued

Explosionproof, and Class 1, Zone 1 AEx d IIC: Special Condition of Use

The flying leads of the apparatus shall be suitably protected against mechanical damage and terminated within an NRTL Approved, Listed or Recognized terminal or junction facility suitable for the location and conditions of use.

Class 1, Zone 1 AEx d IIC: Special Condition of Use

Requires the use of an NRTL Approved, Listed or Recognized cable seal, suitable for the location and conditions of use, installed at the apparatus and prior to the terminal or junction facility.

CLASS , Zone : Notice

Using the box [] provided on the nameplate, the user shall permanently mark the type of protection chosen for the specific installation. Once the type of protection has been marked it shall not be change.

11.4.1.2 Canadian Certificates

CLASS-DIVISION: GAS, DUST and FIBER

Intrinsically Safe for Class I, II, III, Division 1 Groups A,B,C,D,E,F,G

Non-Incendive for Class I, Division 2, Group A,B,C,D

Suitable for Use Class I, II, III, Division 2 A,B,C,D,E,F,G

Intrinsically Safe and Suitable for use when installed per SIEMENS Drawing AT1101030C.

Explosionproof for Class I, II, III, - Division 1, Groups A,B,C,D,E,F,G

DUST IGNITIONPROOF for Class II, III, Division 1 Group E,F,G

FACTORY SEALED, CONDUIT SEAL NOT REQUIRED

CLASS-DIVISION: DUST

Class II, Division 2, Groups E, F, G

ZONE MARKINGS

Intrinsically Safe (GAS): II 1 G

Zone 0, Ex ia IIC Temp. Class: T5, T6

Intrinsically Safe (DUST): II 1 D

Zone 20, Ex iaD 20 IP68 T95°C

Non-Sparking (GAS) , Encapsulation (GAS): II 3 G

Zone 2, Ex nA nC IIC T5, T6

Flameproof (GAS) : II 2 G

Class 1, Zone 1, Ex d IIC T5, T6 Gb

TEMPERATURE CLASS

T5: -40°C to +85°C , T6: -40°C to +75°C

ENCLOSURE RATING

TYPE 6P, IP68 1.8m 24hr

11.4.1.2 Canadian continued

ENTITY PARAMETERS

Ui= 30V, Ii=120mA, Pi=0.9W, Ci= 0uFD, Li= 596uH

CLASS 1, ZONE 0, Special Condition of Use

This product enclosure contains aluminum and is considered to constitute a potential risk of ignition by impact or friction. Care must be taken into account during installation and use to prevent impact and friction.

Explosionproof, and Ex d IIC: Special Condition of Use

The flying leads of the apparatus shall be suitably protected against mechanical damage and terminated within an Canadian Certified terminal or junction facility suitable for the location and conditions of use.

Ex d IIC Special Condition of Use

Requires the use of an Canadian Certified cable seal, suitable for the location and conditions of use, installed at the apparatus and prior to the terminal or junction facility.

Zone : Notice

Using the box [] provided on the nameplate, the user shall permanently mark the type of protection chosen for the specific installation. Once the type of protection has been marked it shall not be changed.

11.4.2 European (ATEX) Certificates

Certification Number: FMATEX0082X

Intrinsically Safe (GAS): Ⓜ II 1 G

Zone 0 Ex ia IIC Ga Temp. Class: T5, T6

Intrinsically Safe (DUST): Ⓜ II 1 D

Zone 20 Ex iaD 20 IP68 T95°C

Certification Number: FMATEX0083X

Non-Sparking (GAS), Encapsulation (GAS): Ⓜ II 3 G

Zone 2 Ex nA nC IIC T5, T6

Certification Number: FMATEX0084X

Flameproof (GAS): Ⓜ II 2 G

Class 1 Zone 1 Ex d IIC T5, T6 Gb

Enclosure Type IP68

Flameproof (DUST): Ⓜ II 2 D

Class 1 Zone 21 Ex tb IIIC T95°C

TEMPERATURE CLASS

T5: -40°C to +85°C, T6: -40°C to +75°C

ENTITY PARAMETERS

Ui= 30V, Ii=120mA, Pi=0.9W, Ci= 0uFD, Li= 596uH

11.4.2 European (ATEX) Certificates continued

ENCLOSURE RATING

IP68 1.8m 24h

Zone 0: Special condition of use (X)

This product enclosure contains aluminum and is considered to constitute a potential risk of ignition by impact or friction. Care must be taken into account during installation and use to prevent impact and friction

Zone : Notice

Using the box [] provided on the nameplate, the user shall permanently mark the type of protection chosen for the specific installation. Once the type of protection has been marked it shall not be changed.

Ex d IIC Special Conditions of Use:

1. The flying leads of the apparatus shall be suitably protected against mechanical damage and terminated within a suitable ATEX Certified Ex d or Ex e terminal or junction facility.
2. The Ex d IIC configuration requires the use of an ATEX Certified cable seal, suitable for the location and conditions of use, installed at the apparatus and prior to the terminal or junction facility.

11.4.3 IEC Certificates

Certification Number: IECEx FMG12.0033X

Intrinsically Safe (GAS): Ⓜ II 1 G
Zone 0 Ex ia IIC Temp. Class: T5, T6

Intrinsically Safe (DUST): Ⓜ II 1 D
Zone 20 Ex iaD 20 IP68 T95°C

Non-Sparking, Encapsulation (GAS): Ⓜ II 3 G
Zone 2 Ex nA nC IIC T5, T6

Certification Number: IECEx FMG 12.0034X
Flameproof (GAS): Ⓜ II 2 G
Class 1 Zone 1 Ex d IIC T5, T6 Gb

Flameproof (DUST): Ⓜ II 2 D
Class 1 Zone 21 Ex tb IIIC T95°C

TEMPERATURE CLASS

T5: -40°C to +85°C, T6: -40°C to +75°C

ENTITY PARAMETERS

Ui= 30V, Ii=120mA, Pi=0.9W, Ci= 0uFD, Li= 596uH

11.4.3 IEC Certificates continued

ENCLOSURE RATING

IP68 1.8m 24hr

Zone 0: Special condition of use (X)

This product enclosure contains aluminum and is considered to constitute a potential risk of ignition by impact or friction. Care must be taken into account during installation and use to prevent impact and friction

Zone: Notice

Using the box [] provided on the nameplate, the user shall permanently mark the type of protection chosen for the specific installation. Once the type of protection has been marked it shall not be changed.

Ex d IIC Special Conditions of Use:

1. The flying leads of the apparatus shall be suitably protected against mechanical damage and terminated within a suitable IECEx Certified Ex d or Ex e terminal or junction facility.
2. The Ex d IIC configuration requires the use of an IECEx Certified cable seal, suitable for the location and conditions of use, installed at the apparatus and prior to the terminal or junction facility.

11.4.4 Required Certification Notices and Warnings

As required by the standards for which this product has been approved, the following Notices and Warnings are required to be listed in this document.

WARNING: FIELD WIRING MUST BE RATED FOR 85C MINIMUM.

WARNING: EXPLOSION HAZARD: DO NOT DISCONNECT EQUIPMENT WHEN A FLAMMABLE OR COMBUSTIBLE ATMOSPHERE IS PRESENT.

WARNING: MAXIMUM OPERATING TEMPERATURE IS 85C.
CAUTION WHEN HANDLING HOT SURFACES

Class 1 Zone 0 and ZONE 0: Special Condition of Use

This product enclosure contains aluminum and is considered to constitute a potential risk of ignition by impact or friction. Care must be taken into account during installation and use to prevent impact and friction

CLASS, Zone and Zone : Notice

Using the box [] provided on the nameplate, the user shall permanently mark the type of protection chosen for the specific installation. Once the type of protection has been marked it shall not be changed.

Explosion-proof: Installation Notice

FACTORY SEALED, NO CONDUIT SEAL REQUIRED

US Listing: Special Condition of Use

The flying leads of the apparatus shall be suitably protected against mechanical damage and terminated within an NRTL Approved, Listed or Recognized terminal or junction facility suitable for the location and conditions of use.

The Class I, Zone 1 AEx d IIC configuration requires the use of an NRTL Approved, Listed or Recognized cable seal, suitable for the location and conditions of use, installed at the apparatus and prior to the terminal or junction facility.

CANADIAN Listing: Special Condition of Use

The flying leads of the apparatus shall be suitably protected against mechanical damage and terminated within a Canadian Certified terminal or junction facility suitable for the location and conditions of use.

The Class I, Zone 1 Ex d IIC configuration requires the use of a Canadian Certified cable seal, suitable for the location and conditions of use, installed at the apparatus and prior to the terminal or junction facility.

ATEX Listing: Special Condition of Use

The flying leads of the apparatus shall be suitably protected against mechanical damage and terminated within a suitable ATEX Certified Ex d or Ex e terminal or junction facility.

The Ex d IIC configuration requires the use of an ATEX Certified cable seal, suitable for the location and conditions of use, installed at the apparatus and prior to the terminal or junction facility.

IECEX Listing: Special Condition of Use

The flying leads of the apparatus shall be suitably protected against mechanical damage and terminated within a suitable IECEX Certified Ex d or Ex e terminal or junction facility.

The Ex d IIC configuration requires the use of an IECEX Certified cable seal, suitable for the location and conditions of use, installed at the apparatus and prior to the terminal or junction facility.

NOTES

1. NO REVISION TO DRAWING WITHOUT PRIOR FM APPROVAL.
2. FOR INSTALLATIONS IN THE U.S., THE ASSOCIATED APPARATUS AND FIELD DEVICE MUST BE FM APPROVED.
3. FOR INSTALLATIONS IN CANADA, THE ASSOCIATED APPARATUS AND FIELD DEVICE MUST BE CANADIAN CERTIFIED.
4. FOR ZONE INSTALLATIONS , THE ASSOCIATED APPARATUS AND FIELD DEVICE MUST BE ATEX / IEC CERTIFIED.
5. ASSOCIATED APPARATUS AND FIELD DEVICE MANUFACTURER/ES INSTALLATION DRAWING MUST BE FOLLOWED WHEN INSTALLING THIS EQUIPMENT.
6. INSTALLATIONS IN THE U.S. SHOULD BE IN ACCORDANCE WITH ANSI/ISA RP12.06.01 INSTALLATION OF INTRINSICALLY SAFE SYSTEMS FOR HAZARDOUS (CLASSIFIED) LOCATIONS⁶ AND THE LATEST EDITION OF THE NATIONAL ELECTRICAL CODE (ANSI/NFPA 70).
7. INSTALLATION IN CANADA SHOULD BE IN ACCORDANCE WITH THE LATEST EDITION OF THE C22.1 CANADIAN ELECTRICAL CODE, PART I.
8. ZONE INSTALLATIONS SHALL BE IN ACCORDANCE WITH LATEST EDITION OF THE WIRING PRACTICES AND OR REGULATIONS FOR THE COUNTRY OF INSTALLATION.
9. FOR INSTALLATION IN THE US AND CANADA, CONTROL EQUIPMENT CONNECTED TO ASSOCIATED APPARATUS MUST NOT USE OR GENERATE MORE THAN 250 VRMS OR VDC.
10. FOR INSTALLATIONS IN EUROPE, CONTROL ROOM EQUIPMENT CONNECTED TO INTRINSICALLY SAFE ASSOCIATED APPARATUS SHALL NOT USE OR GENERATE MORE THAN THE MARKED UM OF THE ASSOCIATED APPARATUS.
11. RESISTANCE BETWEEN INTRINSICALLY SAFE GROUND AND EARTH GROUND MUST BE LESS THAN 1.0 OHM.
12. INSTALLATION OF EXISTING FIELD DEVICE MUST FOLLOW MANUFACTURERS INSTALLATION DRAWINGS.
13. TERMINATE UNUSED LEAD WIRES AS REQUIRED BY NATIONAL, REGIONAL OR LOCAL CODE AND OR PRACTICES.
14. SPLICE DENOTES LEAD WIRE TO LEAD WIRE CONNECTION. INSTALL AS REQUIRED BY NATIONAL, REGIONAL OR LAW AND OR PRACTICES.
15. INSTALL EXTERNAL GROUNDING CONNECTION AS REQUIRED BY NATIONAL, REGIONAL OR LOCAL CODE ANS OR PRACTICES. EXTERNAL GROUNDING CONNECTION WILL ACCEPT UP TO A 10AWG [4mm²] WIRE.
16. THE ENTITY CONCEPT ALLOWS INTERCONNECTION OF INTRINSICALLY SAFE APPARATUS WITH ASSOCIATED APPARATUS WHEN THE FOLLOWING IS TRUE:
 $U_i \Rightarrow U_o$, $I_i \Rightarrow I_o$, $P_i \Rightarrow P_o$; $C_o \Rightarrow$ SUM OF ALL C_i'S + CCABLE; $L_o \Rightarrow$ SUM OF ALL L_i'S + LCABLE.
17. SITRANS AW210 WirelessHART Adapter MODELS: 7MP3111-1AB00-0AA0 and 7MP3111-2AB00-0AA0
 ENTITY PARAMETERS: INTRINSICALLY SAFE
 $U_i = 30V$, $I_i = 120MA$, $P_i = 0.90W$, $C_i = 0UF$, $L_i = 596uH$
 WHEN C_a OF THE BARRIER IS > 22UF, THEN TOTAL CABLE CAPACITANCE SHALL BE LIMITED TO 22UF.
 THE TOTAL CABLE CAPACITANCE PLUS THE TOTAL OF ALL C_i'S SHALL NOT EXCEED THE C_o OF THE ASSOCIATED APPARATUS.
 THE TOTAL CABLE INDUCTANCE PLUS THE TOTAL OF ALL L_i'S SHALL NOT EXCEED THE L_o OF THE ASSOCIATED APPARATUS.
18. THE ASSOCIATED APPARATUS MUST BE A RESISTIVELY LIMITED SINGLE OR MULTIPLE CHANNEL APPROVED / CERTIFIED BARRIER HAVING PARAMETERS LESS THAN THOSE QUOTED, AND FOR WHICH THE OUTPUT AND THE COMBINATIONS OF OUTPUTS IS NON-IGNITION CAPABLE.

WARNINGS

- 1 - TO PREVENT IGNITION OF FLAMMABLE OR COMBUSTIBLE ATMOSPHERE, DISCONNECT POWER BEFORE SERVICING.
- 2 - MAXIMUM OPERATING TEMPERATURE IS 85C. CAUTION IN HANDELING ANY POTENTIALLY HOT SURFACE.
- 3 - FIELD WIRING MUST BE RATED FOR 85C MINIMUM.

AREA CLASSIFICATIONS

HAZARDOUS AREA

INTRINSICALLY SAFE : GAS
 CLASS 1, DIVISION I, II, III GROUPS A,B,C,D,E,F
 CLASS 1, ZONE 0
 SUITABLE FOR
 CLASS I,II,III, DIVISION 2, GROUPS A,B,C,D,E,F,G
 NON-SPARKING
 CLASS 1, ZONE 2 IIC
 INTRINSICALLY SAFE : DUST
 ZONE 20

UNCLASSIFIED AREA

ORDINARY LOCATION

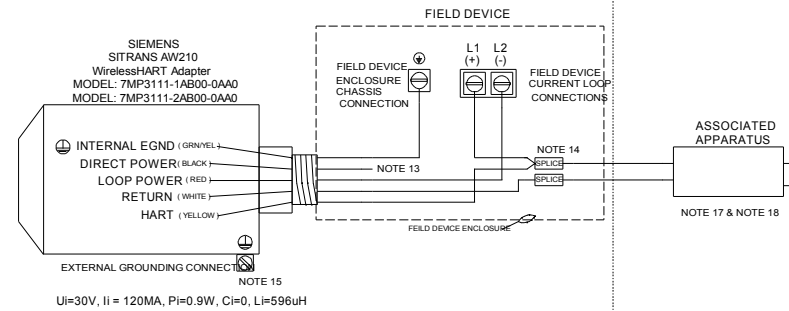
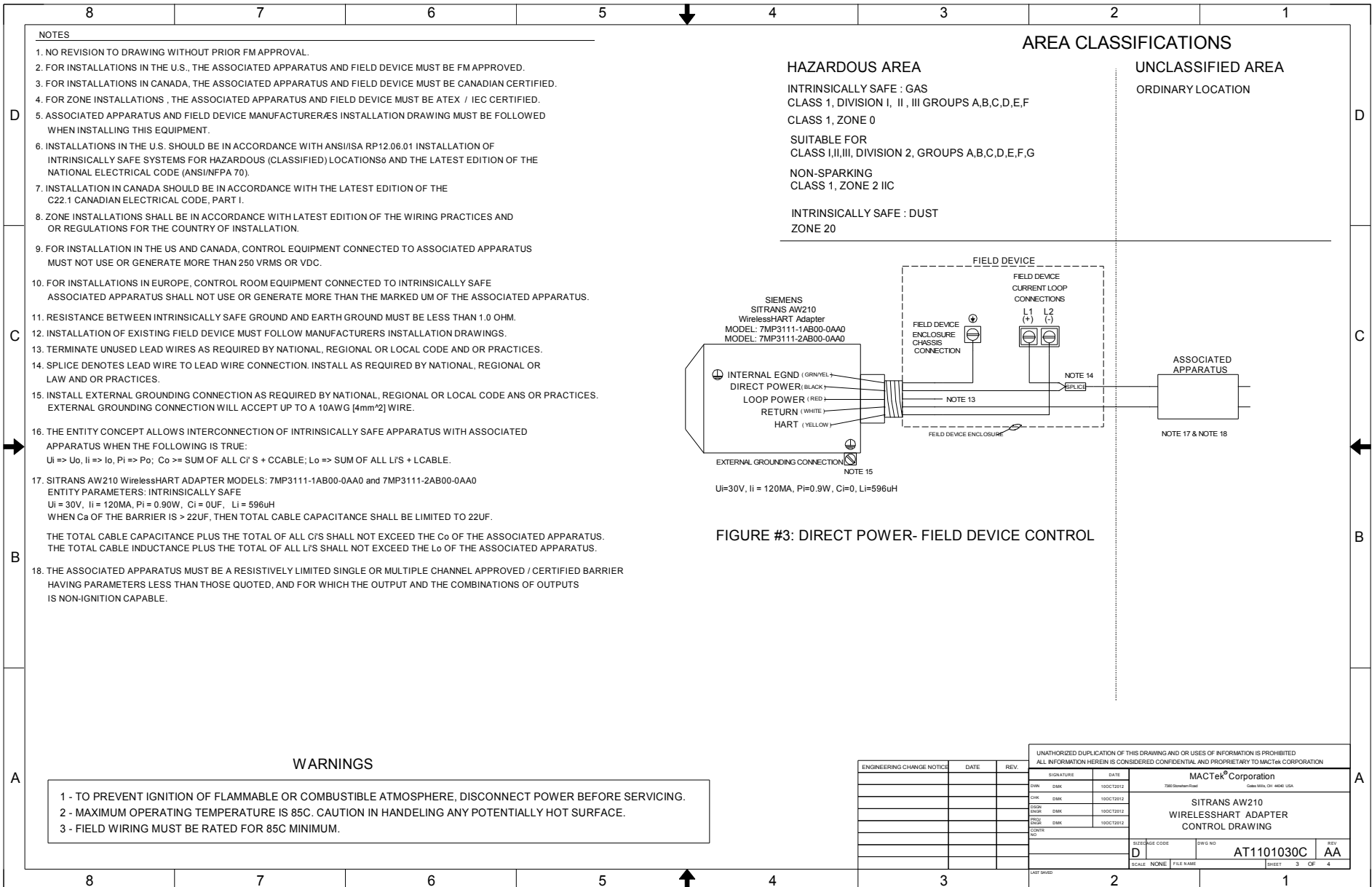
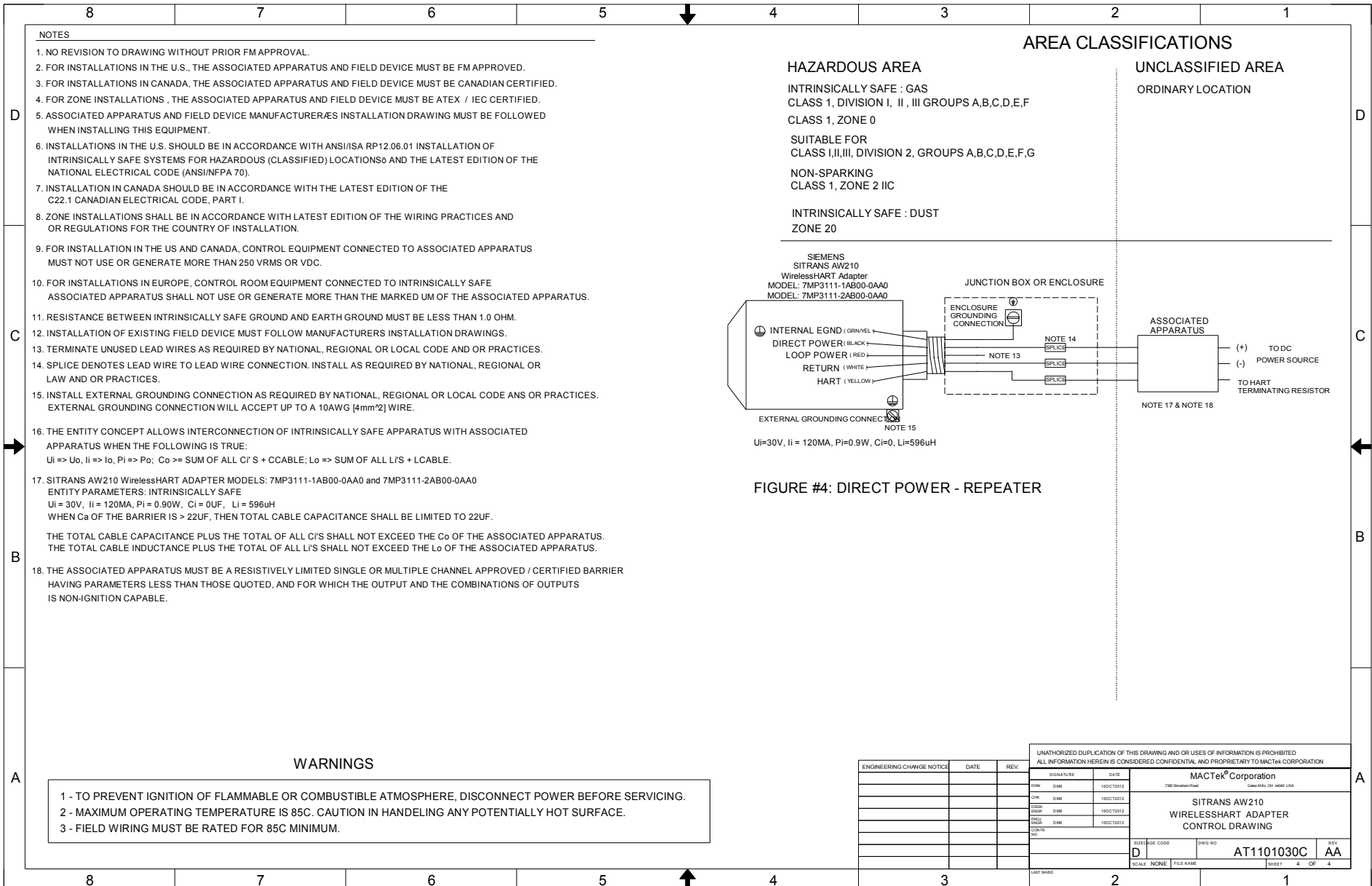

FIGURE # 2: LOOP POWER #2

ENGINEERING CHANGE NOTICE	DATE	REV.

UNAUTHORIZED DUPLICATION OF THIS DRAWING AND OR USES OF INFORMATION IS PROHIBITED ALL INFORMATION HEREIN IS CONSIDERED CONFIDENTIAL AND PROPRIETARY TO MACTEK CORPORATION			
MACTek Corporation			
7360 Stearns Road Columbus, OH 43260 USA			
SITRANS AW210 WIRELESSHART ADAPTER CONTROL DRAWING			
SIGNATURE	DATE	SCALE	REV
DMK DMK	15OCT2012		
DMK DMK	15OCT2012		
DMK DMK	15OCT2012		
DMK DMK	15OCT2012		
CONTR			
NO			
SIZE/CODE		DWG NO	REV
D		AT1101030C	AA
SCALE: NONE		FILE NAME	SHEET 2 OF 4





- NOTES**
- NO REVISION TO DRAWING WITHOUT PRIOR FM APPROVAL.
 - FOR INSTALLATIONS IN THE U.S., THE ASSOCIATED APPARATUS AND FIELD DEVICE MUST BE FM APPROVED.
 - FOR INSTALLATIONS IN CANADA, THE ASSOCIATED APPARATUS AND FIELD DEVICE MUST BE CANADIAN CERTIFIED.
 - FOR ZONE INSTALLATIONS, THE ASSOCIATED APPARATUS AND FIELD DEVICE MUST BE ATEX / IEC CERTIFIED.
 - ASSOCIATED APPARATUS AND FIELD DEVICE MANUFACTURER'S INSTALLATION DRAWING MUST BE FOLLOWED WHEN INSTALLING THIS EQUIPMENT.
 - INSTALLATIONS IN THE U.S. SHOULD BE IN ACCORDANCE WITH ANSI/ISA RP12.06.01 INSTALLATION OF INTRINSICALLY SAFE SYSTEMS FOR HAZARDOUS (CLASSIFIED) LOCATIONS AND THE LATEST EDITION OF THE NATIONAL ELECTRICAL CODE (ANSI/NFPA 70).
 - INSTALLATION IN CANADA SHOULD BE IN ACCORDANCE WITH THE LATEST EDITION OF THE C22.1 CANADIAN ELECTRICAL CODE, PART I.
 - ZONE INSTALLATIONS SHALL BE IN ACCORDANCE WITH LATEST EDITION OF THE WIRING PRACTICES AND OR REGULATIONS FOR THE COUNTRY OF INSTALLATION.
 - FOR INSTALLATION IN THE US AND CANADA, CONTROL EQUIPMENT CONNECTED TO ASSOCIATED APPARATUS MUST NOT USE OR GENERATE MORE THAN 250 VRMS OR VDC.
 - FOR INSTALLATIONS IN EUROPE, CONTROL ROOM EQUIPMENT CONNECTED TO INTRINSICALLY SAFE ASSOCIATED APPARATUS SHALL NOT USE OR GENERATE MORE THAN THE MARKED UM OF THE ASSOCIATED APPARATUS.
 - RESISTANCE BETWEEN INTRINSICALLY SAFE GROUND AND EARTH GROUND MUST BE LESS THAN 1.0 OHM.
 - INSTALLATION OF EXISTING FIELD DEVICE MUST FOLLOW MANUFACTURERS INSTALLATION DRAWINGS.
 - TERMINATE UNUSED LEAD WIRES AS REQUIRED BY NATIONAL, REGIONAL OR LOCAL CODE AND OR PRACTICES.
 - SPLICE DENOTES LEAD WIRE TO LEAD WIRE CONNECTION. INSTALL AS REQUIRED BY NATIONAL, REGIONAL OR LAW AND OR PRACTICES.
 - INSTALL EXTERNAL GROUNDING CONNECTION AS REQUIRED BY NATIONAL, REGIONAL OR LOCAL CODE AND OR PRACTICES. EXTERNAL GROUNDING CONNECTION WILL ACCEPT UP TO A 10AWG [4mm²] WIRE.
 - THE ENTITY CONCEPT ALLOWS INTERCONNECTION OF INTRINSICALLY SAFE APPARATUS WITH ASSOCIATED APPARATUS WHEN THE FOLLOWING IS TRUE:
 $U_i \geq U_o$; $I_i \geq I_o$; $P_i \geq P_o$; $C_o \geq \text{SUM OF ALL } C_i$ 'S + CCABLE; $L_o \geq \text{SUM OF ALL } L_i$ 'S + LCABLE.
 - SITRANS AW210 WirelessHART ADAPTER MODELS: 7MP3111-1AB00-0AA0 and 7MP3111-2AB00-0AA0
 ENTITY PARAMETERS: INTRINSICALLY SAFE
 $U_i = 30V$, $I_i = 120MA$, $P_i = 0.90W$, $C_i = 0UF$, $L_i = 596uH$
 WHEN C_a OF THE BARRIER IS $> 22UF$, THEN TOTAL CABLE CAPACITANCE SHALL BE LIMITED TO 22UF.
 THE TOTAL CABLE CAPACITANCE PLUS THE TOTAL OF ALL C_i 'S SHALL NOT EXCEED THE C_o OF THE ASSOCIATED APPARATUS.
 THE TOTAL CABLE INDUCTANCE PLUS THE TOTAL OF ALL L_i 'S SHALL NOT EXCEED THE L_o OF THE ASSOCIATED APPARATUS.
 - THE ASSOCIATED APPARATUS MUST BE A RESISTIVELY LIMITED SINGLE OR MULTIPLE CHANNEL APPROVED / CERTIFIED BARRIER HAVING PARAMETERS LESS THAN THOSE QUOTED, AND FOR WHICH THE OUTPUT AND THE COMBINATIONS OF OUTPUTS IS NON-IGNITION CAPABLE.

WARNINGS

- TO PREVENT IGNITION OF FLAMMABLE OR COMBUSTIBLE ATMOSPHERE, DISCONNECT POWER BEFORE SERVICING.
- MAXIMUM OPERATING TEMPERATURE IS 85C. CAUTION IN HANDLING ANY POTENTIALLY HOT SURFACE.
- FIELD WIRING MUST BE RATED FOR 85C MINIMUM.

UNAUTHORIZED DUPLICATION OF THIS DRAWING AND OR USES OF INFORMATION IS PROHIBITED ALL INFORMATION HEREIN IS CONSIDERED CONFIDENTIAL AND PROPRIETARY TO MACTEK CORPORATION																																																																								
<table border="1" style="width: 100%; border-collapse: collapse;"> <thead> <tr> <th>ENGINEERING CHANGE NOTICE</th> <th>DATE</th> <th>REV.</th> </tr> </thead> <tbody> <tr><td> </td><td> </td><td> </td></tr> <tr><td> </td><td> </td><td> </td></tr> <tr><td> </td><td> </td><td> </td></tr> <tr><td> </td><td> </td><td> </td></tr> <tr><td> </td><td> </td><td> </td></tr> <tr><td> </td><td> </td><td> </td></tr> <tr><td> </td><td> </td><td> </td></tr> <tr><td> </td><td> </td><td> </td></tr> <tr><td> </td><td> </td><td> </td></tr> <tr><td> </td><td> </td><td> </td></tr> </tbody> </table>	ENGINEERING CHANGE NOTICE	DATE	REV.																															<table border="1" style="width: 100%; border-collapse: collapse;"> <thead> <tr> <th>SIGNATURE</th> <th>DATE</th> </tr> </thead> <tbody> <tr> <td>DMK DMK</td> <td>15OCT2012</td> </tr> <tr> <td>DMK DMK</td> <td>15OCT2012</td> </tr> <tr> <td>DMK DMK</td> <td>15OCT2012</td> </tr> <tr> <td>DMK DMK</td> <td>15OCT2012</td> </tr> <tr> <td>DMK DMK</td> <td>15OCT2012</td> </tr> <tr> <td>DMK DMK</td> <td>15OCT2012</td> </tr> <tr> <td>DMK DMK</td> <td>15OCT2012</td> </tr> <tr> <td>DMK DMK</td> <td>15OCT2012</td> </tr> <tr> <td>DMK DMK</td> <td>15OCT2012</td> </tr> <tr> <td>DMK DMK</td> <td>15OCT2012</td> </tr> </tbody> </table>	SIGNATURE	DATE	DMK DMK	15OCT2012	DMK DMK	15OCT2012	DMK DMK	15OCT2012	DMK DMK	15OCT2012	DMK DMK	15OCT2012	DMK DMK	15OCT2012	DMK DMK	15OCT2012	DMK DMK	15OCT2012	DMK DMK	15OCT2012	DMK DMK	15OCT2012	<p style="text-align: center;">MACTek Corporation</p> <p style="text-align: center;">7360 Steeles Road Gales Mills, OH 44040 USA</p> <p style="text-align: center;">SITRANS AW210 WIRELESSHART ADAPTER CONTROL DRAWING</p> <table border="1" style="width: 100%; border-collapse: collapse;"> <tr> <td style="width: 15%;">SCALE</td> <td style="width: 15%;">NONE</td> <td style="width: 15%;">FILE NAME</td> <td style="width: 15%;">DWG NO</td> <td style="width: 15%;">REV</td> </tr> <tr> <td> </td> <td> </td> <td> </td> <td style="text-align: center;">AT1101030C</td> <td style="text-align: center;">AA</td> </tr> <tr> <td> </td> <td> </td> <td> </td> <td style="text-align: center;">SHEET</td> <td style="text-align: center;">4 OF 4</td> </tr> </table>	SCALE	NONE	FILE NAME	DWG NO	REV				AT1101030C	AA				SHEET	4 OF 4
ENGINEERING CHANGE NOTICE	DATE	REV.																																																																						
SIGNATURE	DATE																																																																							
DMK DMK	15OCT2012																																																																							
DMK DMK	15OCT2012																																																																							
DMK DMK	15OCT2012																																																																							
DMK DMK	15OCT2012																																																																							
DMK DMK	15OCT2012																																																																							
DMK DMK	15OCT2012																																																																							
DMK DMK	15OCT2012																																																																							
DMK DMK	15OCT2012																																																																							
DMK DMK	15OCT2012																																																																							
DMK DMK	15OCT2012																																																																							
SCALE	NONE	FILE NAME	DWG NO	REV																																																																				
			AT1101030C	AA																																																																				
			SHEET	4 OF 4																																																																				