

AD353-129

Rev 2

April 2012

Procidia Control Solutions Feedforward Control

This application data sheet describes several feedforward control methods. Any of these configurations can be readily developed within a Siemens 353 controller.¹

Feedforward control is a method of compensating for process load disturbances before they can affect the primary control variable. This control strategy is particularly beneficial for critical process control loops that are often slow to respond to load disturbances. By reducing the effect of these load disturbances, feedforward control minimizes the magnitude and duration of the control errors that would normally occur without this control strategy.

In the heat exchanger example shown in Figure 1, exit temperature is the primary control variable. The temperature controller (TC) manipulates the flow of

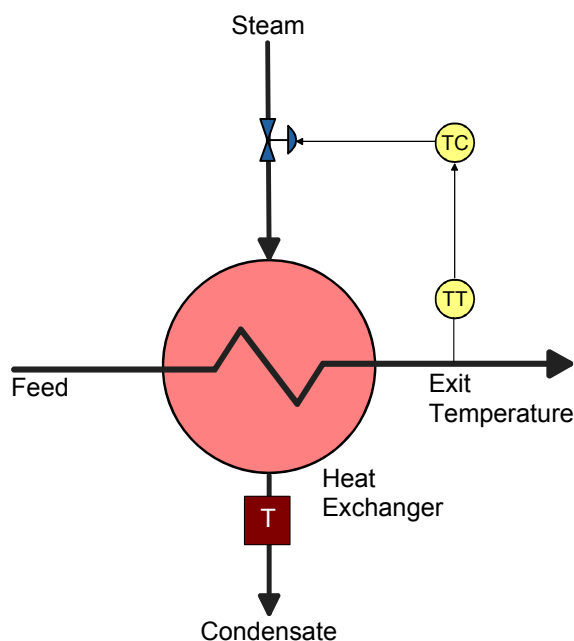

Figure 1 Heat Exchanger Temperature Control

steam to the heat exchanger to control the temperature at setpoint. An increase in the feed flow to the heat exchanger will cause a decrease in the exit temperature. The temperature controller responds to this control error by increasing the steam flow as required to return the temperature to setpoint. The change in feed flow represents a change in load on the heat exchanger and is referred to as a load disturbance. Other load disturbances that can affect the exit temperature are changes in inlet temperature, ambient temperature, and steam pressure.

The temperature controller can compensate for any and all load changes. That is the essential advantage of feedback control. No matter what is causing a change in exit temperature, the controller will detect the error and change the steam flow as required to reduce the error to zero. Figure 2 is an example of the response of a single-loop PI controller to a change in feed flow. As expected, the controller returns the exit temperature to setpoint after the load disturbance from the change in feed flow.

The disadvantage of feedback control is that it can detect the load disturbance only after the disturbance has occurred. Due to the dynamics of the process, the load disturbance will go undetected for some time before the exit temperature begins to change, and then additional time will be required for the exit temperature to respond to the change in steam flow manipulated by the controller to compensate for the new load.

Another disadvantage of feedback control is the potential for unstable operation. Since all feedback control loops will cycle if tuned to respond too quickly, the speed at which the temperature controller can compensate for the disturbance is restricted by the stability limit of the control loop.

¹ See Applications Support at the back of this publication for a list of controllers.

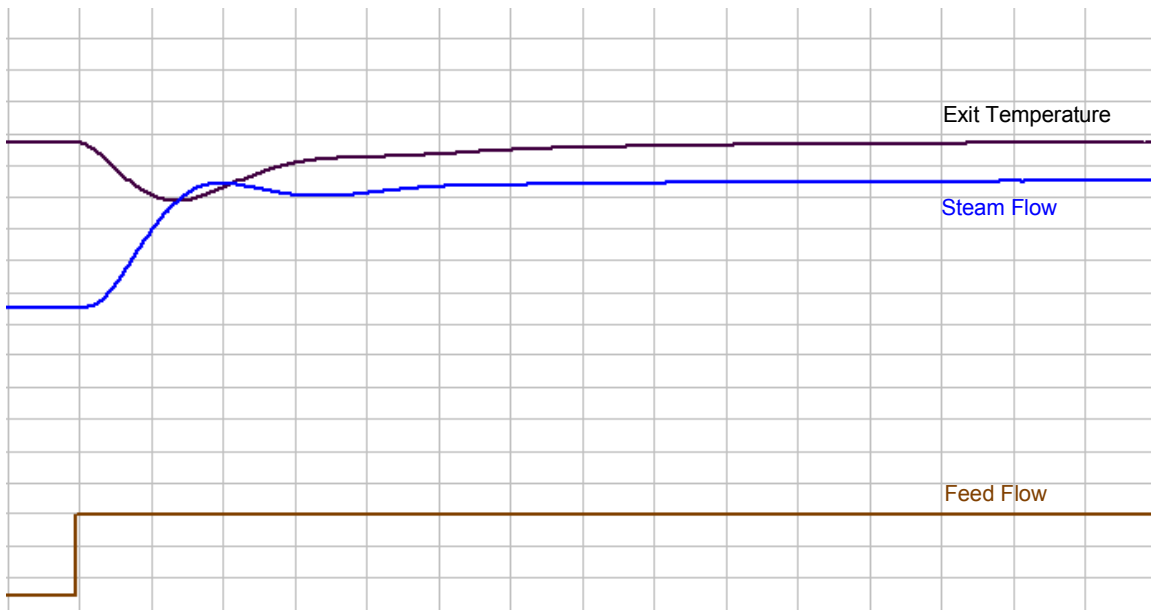

Figure 2 Single-Loop Response to Feed Flow Change

Figure 3 shows an example of feedforward control applied to the heat exchanger temperature control loop. The load disturbance, caused by a change in feed flow, is measured and added directly to the exit temperature controller output. This allows an increase in feed flow to provide an immediate increase in steam flow. With appropriate signal

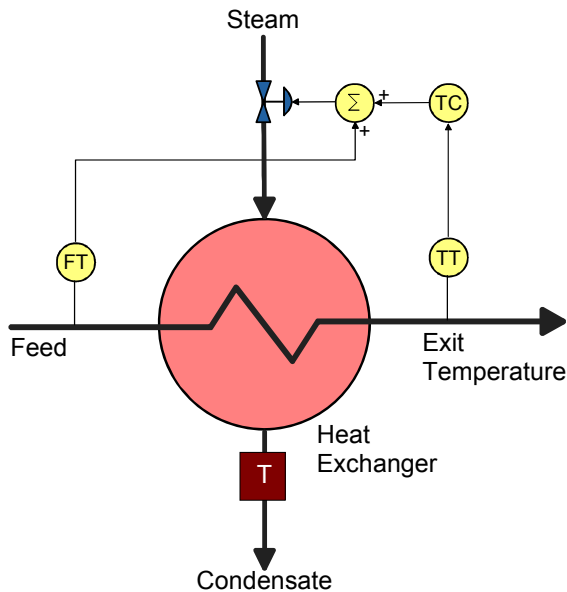

Figure 3 Heat Exchanger Steady State Feedforward Control

scaling and dynamic compensation, it is theoretically possible to match the change in valve position to the change in feed flow so that there is no effect whatsoever on the exit temperature.

It should be noted that feedforward is an open loop control strategy. The change in the manipulated variable (steam flow) has no effect on the load variable (feed flow). Therefore, it is not possible for a feedforward loop to become unstable.

For feedforward to be effective, it must be configured so that the change in load moves the manipulated variable in the right direction, the right amount, and at the right time. The right direction can be deduced from an understanding of the process. The right amount and the timing may be estimated from process knowledge, but is more often determined by empirical testing of the control loop and its response.

If feedforward adds too much steam for an increase in feed flow, the exit temperature will increase, and there will be a control error in the opposite direction from that caused by the load change. The control configuration must include a gain adjustment so that the magnitude of the change in the manipulated variable can be adjusted relative to the change in the load variable.

A similar problem occurs if the change in steam flow is too soon or too late. Since exit temperature will respond at different rates to a change in feed flow and a change in steam flow, it may be necessary to slow down (or speed up) the response of the

manipulated variable to a change in feed flow. The control configuration must include dynamic compensation to synchronize the response of the manipulated variable with the response of the load variable. This is accomplished by adding lead or lag, and perhaps dead time, to the feedforward signal.

Although feedforward control provides significant benefits, it is not practical to control a process by feedforward alone. Feedforward can only compensate for measured load variables. It is not practical to measure every conceivable load variable that can disturb a process. In addition, it is not possible to provide perfect feedforward compensation for the load variables that are being measured. Even the most sophisticated feedforward control scheme is not capable of controlling the process variable exactly at setpoint. Therefore, it is always necessary to use feedback control in conjunction with feedforward control to “trim” or “bias” the feedforward model.

For feedforward control, consider one of the techniques below, which are discussed in detail in the remainder of this publication.

- Steady State Feedforward
- Impulse Feedforward
- Model Predictive Feedforward

STEADY STATE FEEDFORWARD

The steady state feedforward configuration is shown in Figures 4 and 5. The PID function block in loop 1 manipulates its output to control the exit temperature at the setpoint value from the SETPT block.

The feed flow signal is the load variable for implementing feedforward control. In this application example the feed flow signal is acquired using Ethernet I/O and brought into the 353 (loop 2) through the AIE1 function block. The lead/lag block (LL1) provides adjustable dynamic compensation. It can be configured to provide lag or lead compensation. A dead time block (DTM1) has also been included for any dead time compensation that may be required (see AD353-127 for dead time compensation techniques).

The proportional-only controller (PD) in loop 2 provides signal scaling and bias for the feedforward signal. If the PD controller is configured for direct action, the output signal is determined by the following equation:

$$CO = PG(P - S) + MR$$

where:

CO is controller output

PG is proportional gain

P is process variable (feed flow)

S is setpoint from SETPT block

MR is manual reset

The values for S and MR are initialized whenever the loop is switched to the manual mode. The “not auto” (NA) status signal from the A/M transfer switch in loop 1 will force the SETPT block in loop 2 to track the feed flow signal and the manual reset of the PD block to track the output of the A/M block. When the loop is returned to auto, the values of S and MR are held at the values of their respective track variables at the moment the transfer is made. Since $P=S$ and MR equals the valve signal, the output of the PD block is initialized at the current valve output. Any subsequent change in the feed flow will change the output of the PD block by an amount equal to $PG(P - S)$.

Math block MTH1 in loop 1 adds the feedforward component from the PD block to the output of the PID exit temperature controller. Except as filtered by the lag block (LL1), this provides an immediate change in the valve signal for changes in feed flow. The characterizer block (CHR1) is available to compensate for any nonlinearity in the relationship between valve position and steam flow to the heat exchanger.

Notice that MTH1 is configured with a – 50% bias value. This allows the PID controller output to trim the feedforward component in both a positive and negative direction. When the PID block output is at midscale (50%), the controller output signal is cancelled by the bias and the feedforward component is passed through without bias. However, the controller can adjust the valve loading signal up or down by varying its output above or below midscale respectively.

The A/M transfer block in loop 1 allows the operator to switch between auto and manual modes of operation. To provide bumpless transfer from manual to auto, the PID controller must be initialized at a value that will allow the MTH1 function block to track the output of the A/M block in the manual mode. This is accomplished by “back calculating” the appropriate reset feedback in math block MTH2. In manual, the PID controller tracks the feedback signal provided by the MTH2 block and the PD controller

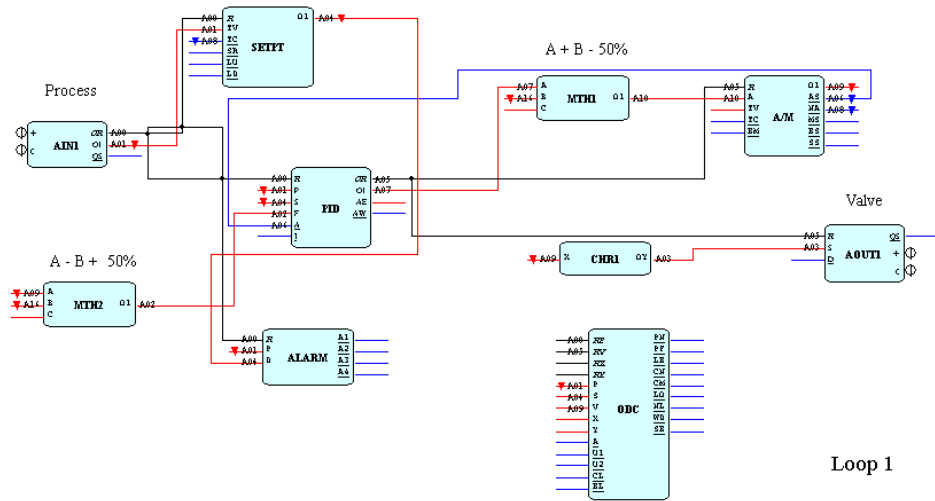

Figure 4 Exit Temperature Controller with Steady State Feedforward Control (CF353-129SS)

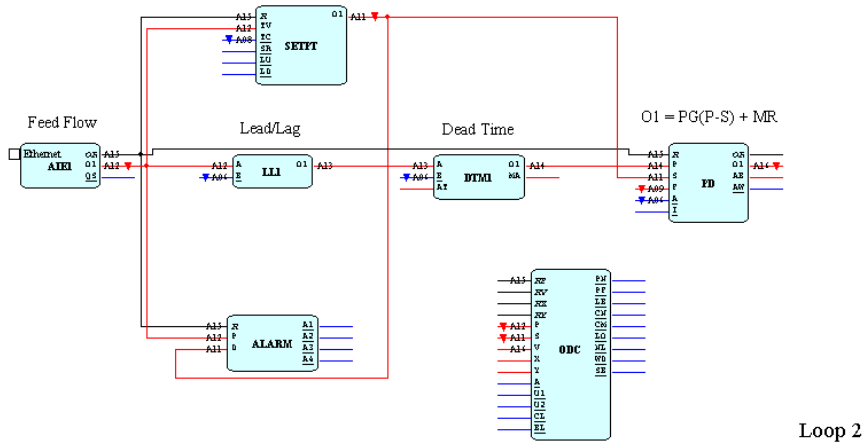

Figure 5 Steady State Feedforward Computation for Exit Temperature Controller (CF353-129SS)

tracks the output of the A/M block. This forces the output of the PID block to midscale (50%); which forces the output of the MTH1 block to match the output of the A/M block.

An example of the response to a feed flow change for this example is shown in Figure 6. Compared with the single loop only response in Figure 2, the feedforward compensation has reduced the effect of a feed flow load disturbance significantly. Depending on the dynamic interaction between the feed forward variable (feed flow) and the controlled variable (exit temperature), the amount of improvement may be limited. The tuning of the feedforward compensation is also critical to the performance of the feedforward compensation.

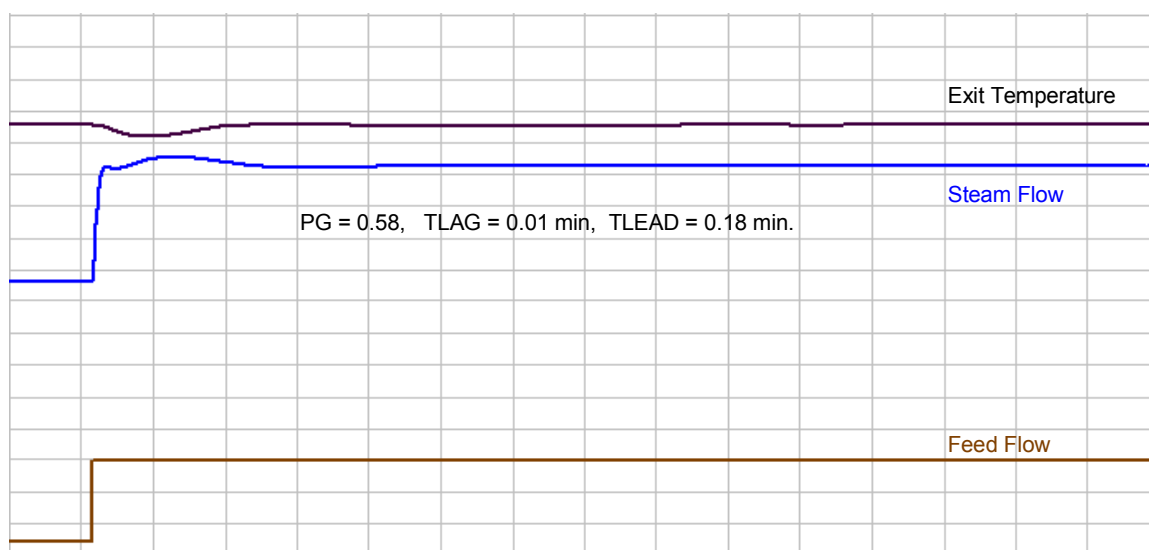

Figure 6 Response to a Feed Flow Change with Feedforward

Tuning

In a feedforward loop, the primary feedback controller must be tuned before tuning the feedforward compensation. To minimize the effect of feedforward while tuning the primary controller, set the lag block (LL1) time constant (TLAG) and the PD controller gain (PG) to their minimum values. The feedback controller can then be tuned using any of the standard methods including AUTOTUNE in a 353.

Next, the feedforward gain and time constant are tuned for the best feedforward compensation. With exact compensation, a change in feed flow would have little or no effect at all on the exit temperature. However, exact compensation is often not possible because a simple lead or lag response cannot compensate for the more complex process dynamics normally encountered. Therefore, the objective is to

minimize the change in the controlled variable for a change in the load variable.

For tuning the feedforward response, it is most convenient if the load can be adjusted to change the feedforward variable. When this is not possible, it is necessary to observe and, preferably, record the effect of changes as they occur. A record of the valve position is particularly useful for tuning.

Figure 7 shows four feedforward tuning examples and the resulting valve positions. In all cases, a step change occurred at the instant the valve plot undergoes a step change upward. The horizontal dashed line represents the new steady state valve position that returns the controlled variable to

setpoint. Dynamic compensation has been minimized for these examples.

Example A shows the effect of too much feedforward gain. Feedforward moves the valve too far initially, and the feedback controller must reduce its output to compensate for the over-correction. The only way the controller can accomplish this is to integrate a control error caused by the initial overcorrection.

Example B shows the effect of too little feedforward gain. Feedforward does not move the valve far enough initially, and the feedback controller must increase its output to compensate for the under-correction. Again, integrating a control error is required.

In example C, the feedforward gain is set correctly. The initial valve position achieved by feedforward is the same position that satisfies the feedback

controller at steady state. However, the transient increase in valve position after the initial step indicates that the controlled variable did not remain at setpoint initially. Feedforward was too late to prevent the transient control error. Clearly, feedforward cannot be expected to respond before the load change occurs. However, lead compensation provides an initial kick to minimize the effect of being late.

In example D, the feedforward gain is also set correctly. However, in this case, the transient decrease in valve position indicates that the feedforward response was too early. Lag compensation can minimize the effect of being too early.

Typically, the feedforward gain (PG) should be adjusted to the correct value before adjusting the lead or lag settings. Then, find the dynamic compensation that minimizes the transient effect.

The dynamic compensation will rarely be perfect due to the complex nature of the process dynamics.

Comparison with Other Methods

Steady state feedforward is relatively simple to implement and tune. However, it is important to realize that this method of feedforward control can prevent the feedback controller from stroking the valve completely. If, for example, the feedforward component is contributing more than 50% to the valve signal, the feedback controller will not be able to bias the feedforward sufficiently in the negative to close an air-to-open valve. This does not normally occur unless the feedforward component is badly misadjusted.

If a sustained control offset develops due to the biasing problem described above, momentarily switch the loop to manual to re-initialize the controllers and then switch the loop back to auto to resume control.

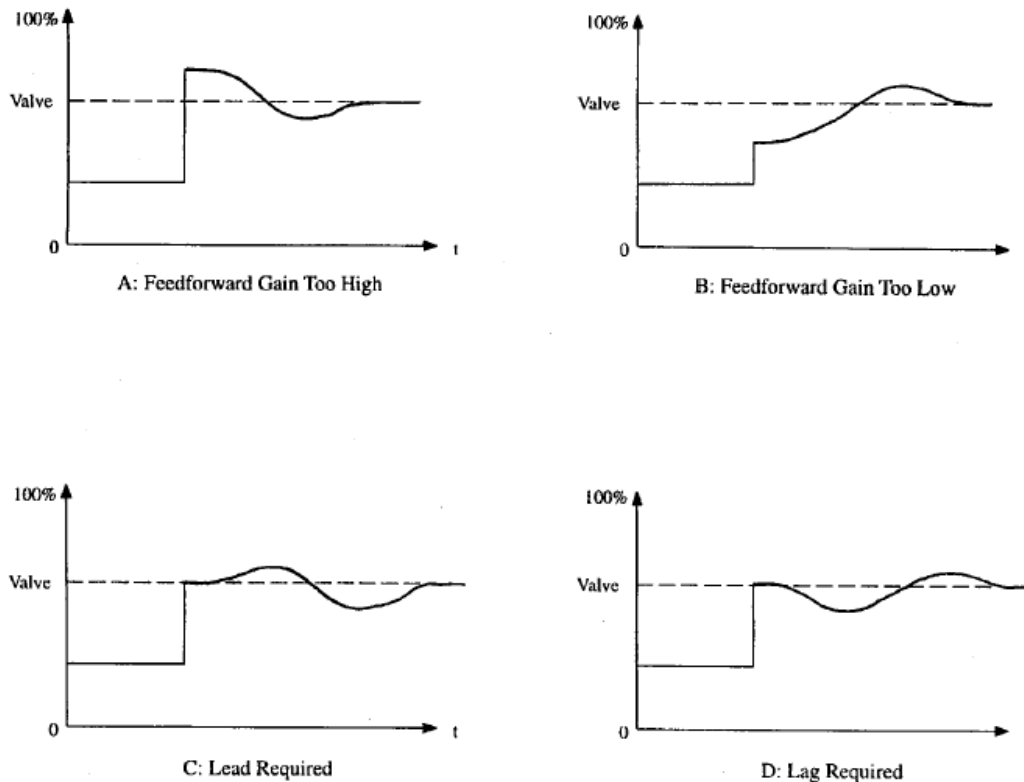

Figure 7 Feedforward Tuning Examples

IMPULSE FEEDFORWARD

Impulse feedforward derives its name from the fact that the feedforward (load) variable generates an impulse that provides a transient bias to the controller output. The valve loading signal is the sum of the PID controller output and the feedforward impulse. This feedforward technique is shown in Figure 8.

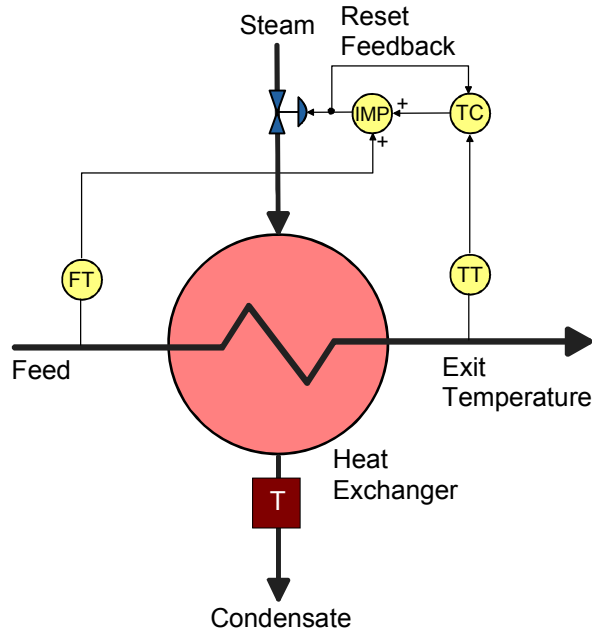

Figure 8 Impulse Feedforward

Figure 9 shows the combination of a deviation amplifier (DAM_) block and a lag (LL_) block that is used to implement the impulse feedforward. The load variable is connected to the A and B inputs (B via the lag block), and the controller output is connected to the C input. At steady state, A and B cancel one another, and the output of the deviation amplifier is simply the value of the C input (controller output).

For a step change in the load variable, there is an immediate change (impulse) in the output of the deviation amplifier. However, as the lag responds to the step change, the A input is increasingly cancelled by the B input, until at steady state the load variable contributes nothing to the output of the deviation amplifier. The initial impulse decays to zero, and the output of the deviation amplifier returns to the value of the controller output (input C).

An impulse that decays to zero does not provide the steady state change in the manipulated variable that is necessary to compensate for the load disturbance. However, as shown in Figure 10, the output of the deviation amplifier provides external reset feedback to the controller. This allows the impulse to drive the reset (integral) component and force the controller output to a new steady state operating value. If the lag time (TLAG) is set equal to the integral time, the reset component will complement the decaying impulse. The sum of these two transients will provide a sustained step change in the output of the deviation

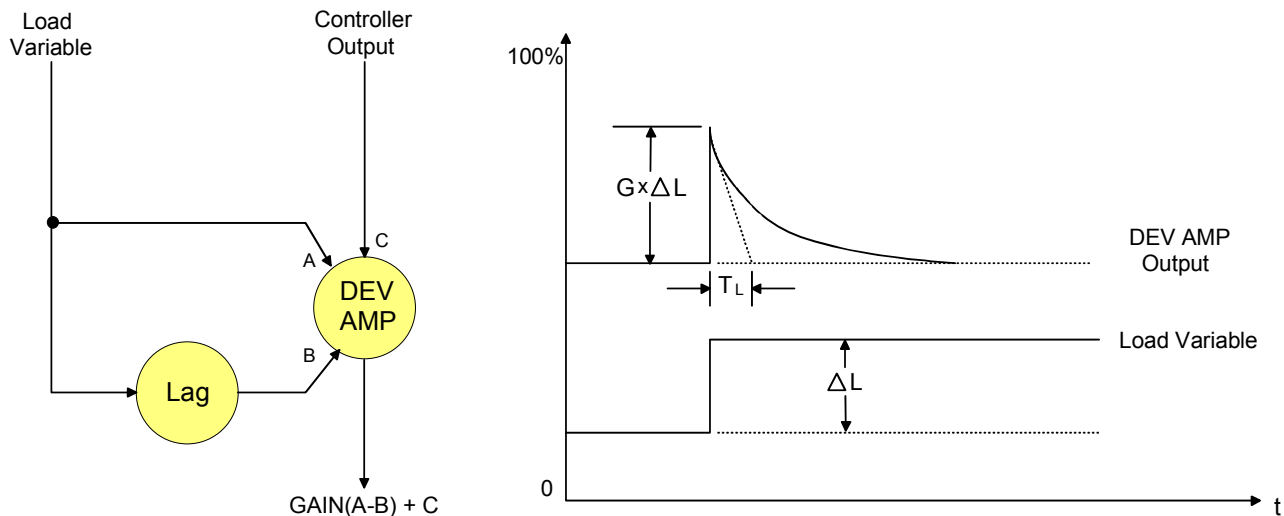

Figure 9 Impulse Function

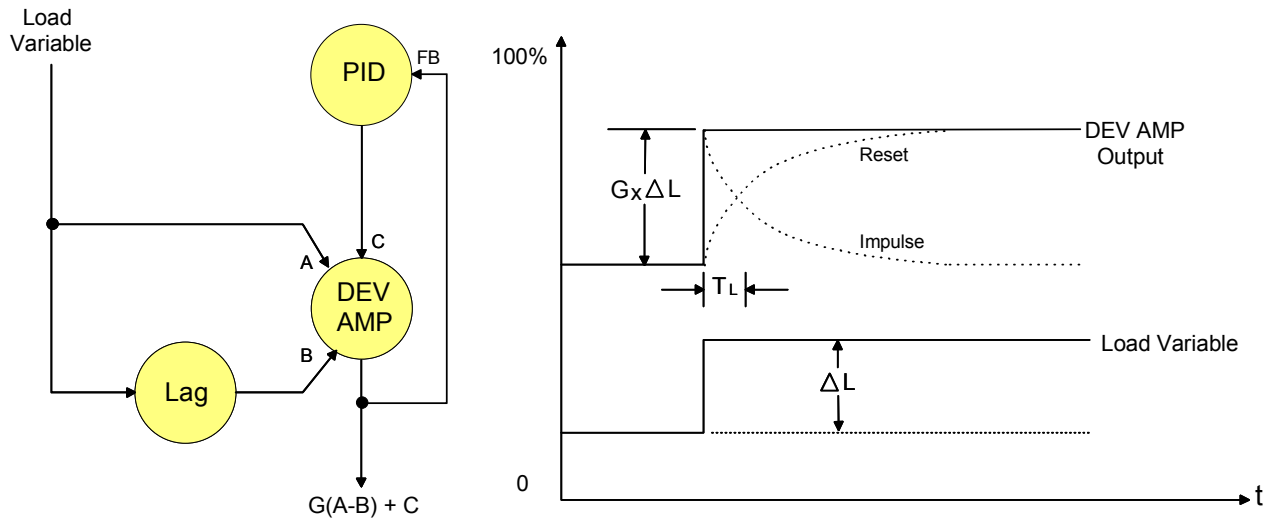

Figure 10 Impulse Plus Reset Feedback

amplifier. This achieves a steady state change in valve loading without integrating a control error or adding a steady state bias.

Impulse feedforward can also provide dynamic compensation by setting the lag time (TLAG) to be less than or greater than the integral setting (TI) of the controller. For lead response, TLAG must be less than TI, and for lag response, TLAG must be greater than TI.

Configuration

Figure 11 shows the configuration for impulse feedforward. The PID controller manipulates its output to control the exit temperature at setpoint. The feed flow signal is the load variable for implementing feedforward control. This signal is applied directly to one side of a deviation amplifier (DAM1) and indirectly through a lag block (LL1) to the other side of the deviation amplifier. If the application requires an inverse relationship between the valve signal and the load variable, these connections to the deviation amplifier must be reversed. A change in feed flow generates an impulse as described above.

The A/M transfer switch allows the operator to switch between auto and manual modes of operation. To provide bumpless transfer from manual to auto, the auto status (AS) signal from the A/M block forces the PID block to track the valve signal and the lag block (LL1) to bypass the lag function.

If desired, a characterizer block can be inserted in the valve loading, as shown in Figure 4 for the steady state feedforward configuration. However, the external feedback for the PID block must “tee off” upstream of the characterizer block.

Tuning

Impulse feedforward is tuned in much the same way as steady state feedforward. The main difference is the manner in which dynamic compensation is accomplished when using impulse feedforward.

With the gain (GAIN) of the deviation amplifier (DAM1) and the time constant (TLAG) of the lag block (LL1) set at minimum values, the feedback controller (PID) can be tuned using any of the preferred methods.

Before doing tests to determine the feedforward gain, the lag time constant should be set equal to the integral time constant of the controller (TLAG = TI). This adjusts the impulse for no lead or lag. Use examples A and B in Figure 7 as a guide to find the correct feedforward gain setting.

With the correct feedforward gain, use examples C and D in Figure 7 to determine the need for lead or lag action. If lead is required, decrease the lag time constant (TLAG) and if lag is required, increase the lag time constant.

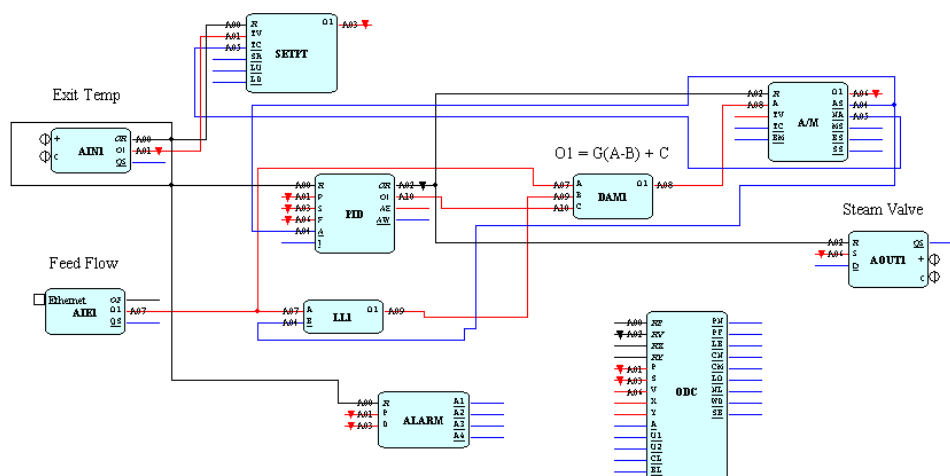

Figure 11 Impulse Feedforward Configuration (CF353-129IM)

The steady state gain (G) of the impulse function is affected by both the deviation amplifier gain adjustment ($GAIN$) and the ratio of the integral and lag time constants as follows:

$$G = GAIN \left(\frac{TLAG}{TI} \right)$$

To retain the effective feedforward gain for changes in $TLAG$, recalculate the gain of the deviation amplifier ($GAIN$) per the following equation:

$$GAIN = G \left(\frac{TI}{TLAG} \right)$$

Suppose, for example, that the feedforward gain was set for 1.2 when $TLAG = TI$. If the lag time ($TLAG$) is readjusted to $0.8TI$ to achieve a leading response, the $GAIN$ of the deviation amplifier should be readjusted to $(1.2)/(0.8)$ or 1.5 to retain the original feedforward gain. It will be necessary to readjust $GAIN$ for every value of $TLAG$ that is tried while conducting experiments to determine the optimum value of $TLAG$.

Comparison with Other Methods

Impulse feedforward is accomplished with a simple configuration. It also eliminates completely the potential bias problem that can occur with steady state feedforward.

The only disadvantage of impulse feedforward is the potentially disconcerting interaction among the tuning constants during the tuning process. The tuning procedure is essentially the same in both cases, but the interaction must be understood to avoid frustration.

MODEL PREDICTIVE FEEDFORWARD

Model predictive feedforward uses a rigorous mathematical model of the process to calculate the value of the manipulated variable as a function of one or more load variables. The primary feedback controller "trims" the model to compensate for modeling errors or unmeasured load disturbances.

As shown in Figure 12, both the feed flow and the feed temperature are measured. The output of the temperature controller (TC) represents the exit temperature. In this application, the heat required to raise the feed flow to the desired exit temperature can be calculated using the following equation.

$$Q = c_p F_f \Delta T$$

where:

Q is heat transfer rate [e.g. BTU/hr]

c_p is specific heat [e.g. BTU/(lb·°F)]

F_f is feed flow (mass) [e.g. lb/hr]

ΔT is change in temperature [e.g. °F]

The heat supplied by the steam can be calculated using the following equation:

$$Q = \lambda F_s$$

Where:

Q is heat transfer rate [e.g. BTU/hr]

λ is the latent heat of steam [e.g. BTU/lb]

F_s is steam flow (mass) [lb/hr]

This equation is used to calculate the value of the manipulated variable in a model predictive feedforward configuration. For other applications, it will be necessary to use whichever first principles (heat balance, material balance, etc.) are appropriate to derive a rigorous mathematical model.

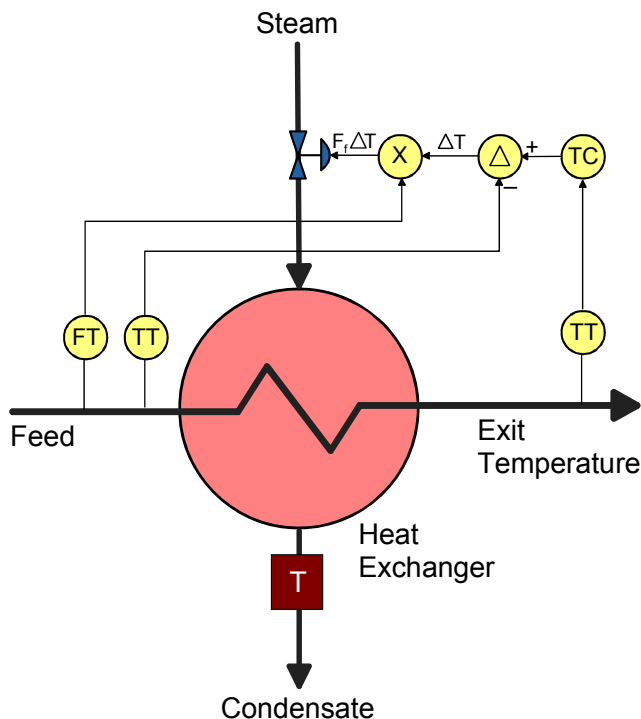

Figure 12 Model Predictive Feedforward

Configuration

The configuration for model predictive feedforward is shown in Figure 13. The math block (MTH1) is used to calculate the steam flow as a function of feed flow, feed temperature, and exit temperature setpoint. Note that the output of the exit temperature controller is used instead of the actual exit temperature setpoint as a convenient method of providing feedback trim to the feedforward calculation. Otherwise, another math block would be required to implement feedback trim.

In addition, if both the setpoint and the controller output are used in the feedforward calculation, there will be a double correction whenever the setpoint is changed. This configuration avoids that problem. If the model provides perfect steady state feedforward compensation, the temperature controller will be satisfied when the output equals the desired exit temperature. Otherwise the PID block will bias the ΔT calculation as required to drive the temperature to setpoint.

The equation derived above can be implemented using a single configurable math block (MTH_). A lead/lag block (LL_) provides dynamic lead or lag compensation. A dead time block (DTM_) provides any dead time compensation that may be required. Although all load variables may require dynamic compensation, it is usually more critical on load variables that move more quickly such as flow.

The A/M transfer switch allows the operator to switch between auto and manual modes of operation. To provide bumpless transfer from manual to auto, the PID block must be initialized at a value that will allow the math block (MTH1) to track the output of the A/M block in the manual mode. This is accomplished by “back calculating” the appropriate reset feedback in math block MTH2. In manual, the PID block tracks the feedback signal provide by MTH2 and the AS status from the A/M block bypasses the dynamic functions of the LL_ and DTM_ blocks.

If desired, a characterizer block can be inserted in the valve signal, as shown in Figure 4 for the steady state feedforward configuration. However, input A to MTH2 must “tee off” upstream of the characterizer block to calculate the correct external feedback for the PID block. Alternatively, if a steam flow measurement is available, this configuration can be modified to provide a setpoint to a secondary steam flow controller in cascade. See AD353-128 for more information on Cascade Control.

The Siemens 353 controller uses real (floating point) numbers between blocks. This enables engineering units to be used for block interconnection signals. The PID block output is scaled to represent the exit temperature with a range of 0 to 200°F. The signal out of the MTH1 block represents steam flow. Scaler block SCL1 provides a steam flow range to the analog output block so it can convert the steam flow range of 0 to 6000 lbs/hr to 0 to 100% valve signal. The MTH2 block output signal represents exit temperature for reset feedback to the PID block. The calculations for the MTH_ blocks were derived as follows:

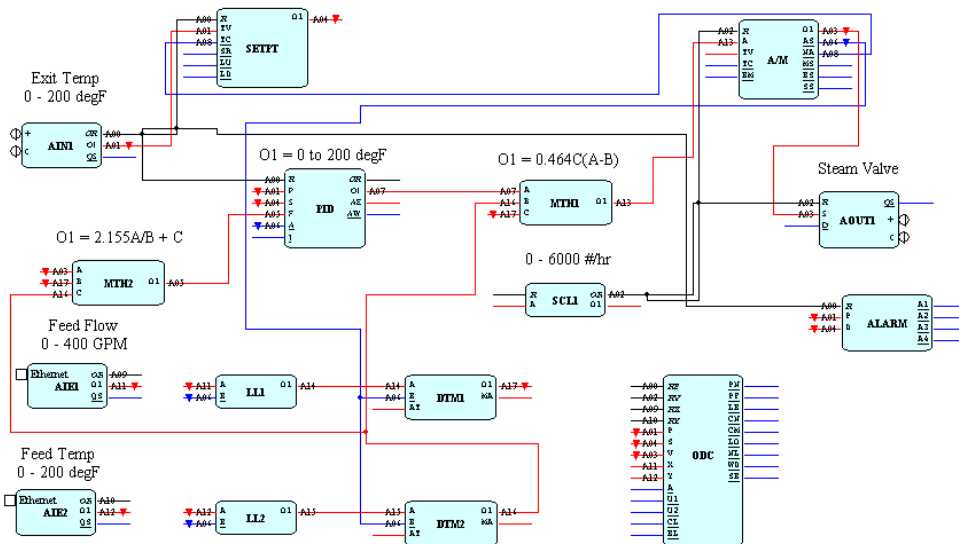

Figure 13 Model Predictive Feedforward Configuration (CF353-129MP)

$$\text{MTH1 } F_s = \left(\frac{C_p}{\lambda}\right)(60 \rho F_f)(T_e - T_f)$$

$$\text{MTH2 } T_e = \left(\frac{\lambda}{C_p}\right)\left(\frac{F_s}{60 \rho F_f}\right) + T_f$$

- Ff (Feed Flow) 0 to 400 GPM
- Tf (Feed Temp) 0 to 200 °F
- Te (Exit Temp)..... 0 to 200 °F
- Fs (Steam Flow) 0 to 6000 lbs/hr
- Cp (specific heat) 0.8 BTU/lb (feed) °F
- ρ (density)..... 8.25 lb (feed)/ gallon
- λ (latent heat of steam).... 853.5 BTU/lb of steam

Tuning

With model predictive feedforward, the mathematical model establishes the relationship between the manipulated variable and the load variables. Therefore, there is no feedforward gain adjustment, except that which is already built into the model. It is necessary to determine only the type of dynamic compensation required and to tune it in much the same manner as described for steady state feedforward.

Comparison with Other Methods

Model predictive feedforward is the most sophisticated of the three methods described and has the potential to provide the best performance. It can compensate for more than one load variable and is based on fundamental knowledge of the process.

This method requires more design effort than either the steady state or impulse feedforward methods. However, the effort required will usually be rewarded by significant improvement in control loop performance.

APPLICATIONS

The feedforward control techniques described in this publication are applicable to any process control loop with measurable load disturbances. Examples are boiler drum level control, composition control in distillation columns, and pH control in waste water treatment.

Application Support

User manuals for controllers and transmitters, addresses of Siemens sales representatives, and more application data sheets can be found at www.usa.siemens.com/ia. To reach the process controller page, click **Process Instrumentation** and then **Process Controllers and Recorders**. To select the type of assistance desired, click **Support** (in the right-hand column). See AD353-138 for a list of Application Data sheets.

The configuration(s) shown in this publication were created in Siemens iconfig™ Graphical Configuration Utility. Those with CF353 in parenthesis in the Figure title are available using the above navigation, then click **Software Downloads > 353 Feedforward Control (Reference AD353-129)**.

The configuration(s) can be created and run in a:

- Model 353 Process Automation Controller
- Model 353R Rack Mount Process Automation Controller*
- ilpac™ Internet Control System*
- Model 352Plus™ Single-Loop Digital Controller*
 - * Discontinued model

ilpac, ilconfig, Procidia, and 352Plus are trademarks of Siemens Industry, Inc. Other trademarks are the property of their respective owners. All product designations may be trademarks or product names of Siemens Industry, Inc. or other supplier companies whose use by third parties for their own purposes could violate the rights of the owners.

Siemens Industry, Inc. assumes no liability for errors or omissions in this document or for the application and use of information in this document. The information herein is subject to change without notice.

Siemens Industry, Inc. is not responsible for changes to product functionality after the publication of this document. Customers are urged to consult with a Siemens Industry, Inc. sales representative to confirm the applicability of the information in this document to the product they purchased.

Control circuits are provided only to assist customers in developing individual applications. Before implementing any control circuit, it should be thoroughly tested under all process conditions.

Copyright © 2012, Siemens Industry, Inc.