

ST-50 Transducer

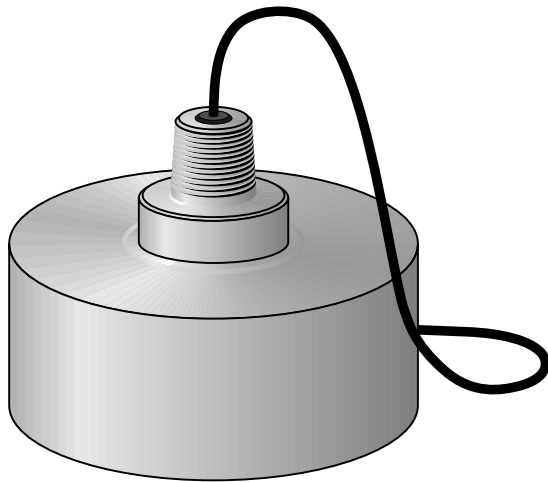

Instruction Manual

PL-524

December 1996

ABOUT THE TRANSDUCER

The ST-50 series of transducers operates in association with Milltronics ultrasonic level monitoring products.

The transducer converts the electrical energy of the transmit pulse from the transceiver into acoustical energy. It then converts the acoustical energy of the echo back into electrical energy for the transceiver receive period.

The effective acoustical energy is emitted from the transducer face and radiated outward, decreasing in amplitude at a rate inversely proportional to the square of the distance. Maximum power is radiated axially (perpendicular) from the transducer face in a line referred to as the axis of transmission. Where power is reduced by half (-3 dB), a conical boundary defining the sound beam, centered about the axis of transmission is established. The diametric measurement of the cone in degrees defines the beam angle. Impedance matching techniques are used to optimize the transfer of power from the transducer into air and vice versa.

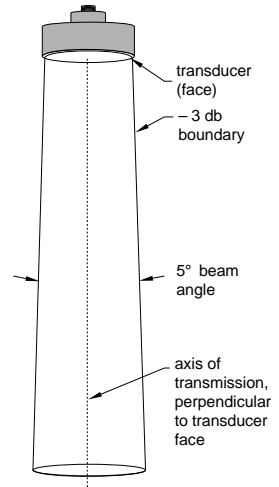

SPECIFICATIONS

- Model : » ST-50
- Measurement range : » typically 0.3 m -15 m (1-50 ft)
- Environmental:
- » location: » indoor/outdoor
 - » altitude: » 2000 m maximum
 - » ambient temperature: » -20 to 70 °C (-5 to 158 °F)
 - » pollution degree: » 4
- Supply source: » transducer shall only be supplied by Milltronics certified controllers
- Frequency : » typically 44 KHz
- Beam angle : » 5°
- Weight* : » 3.9 Kg (8.5 lb)
- Construction :
- » CPVC housing with polyurethane face
 - » 1" NPT mounting/conduit connection with neoprene jacketed cable
 - » totally encapsulated
 - » options: » flanging: factory flanged, consult Milltronics
 - » facing: » CPVC for corrosive applications
 - » Teflon® for corrosive applications
 - » polyethylene foam for dry-dusty applications
- Separation : » typically 365 m (1200 ft) from transceiver
- Approvals : » CE[▼], CSA, FM, SAA, BASEEFA / CENELEC

* approximate weight of transducer with standard cable length and unflanged

▼ EMC performance available upon request

Teflon® is a registered trade mark of Dupont

OUTLINE AND CONNECTION

*Cable length: » standard: 5 m (16 ft)
 » optional: consult Milltronics

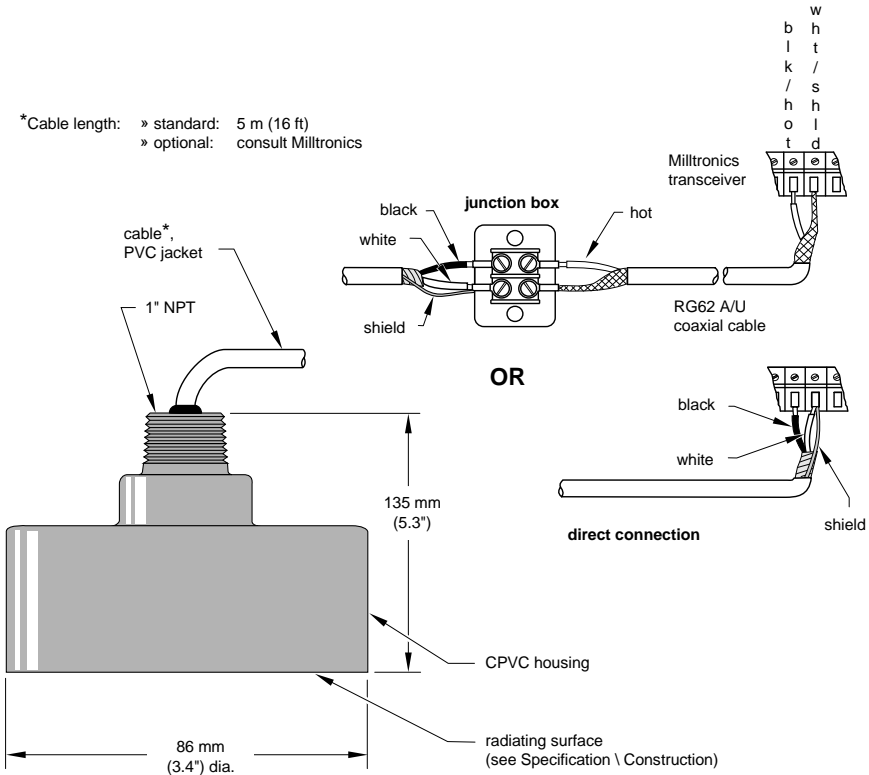

DO'S AND DON'TS

Do not route cable openly in raceways.

For optimum isolation against electrical noise, run cable in a grounded metal conduit with no other cabling (except temperature sensor). Ground shield only at transceiver. Insulate shield at junctions to prevent inadvertent grounding.

Installation shall only be performed by qualified personnel and in accordance with local governing regulations.

Seal all thread connections to prevent ingress of moisture.

Do not run cable near high voltage or current runs, contactors and SCR control drives.

For BASEEFA Zone 0, cable must be terminated externally to Zone 0 in an appropriate manner. The cable must be protected against mechanical damage, and arrangements sealed to prevent migration of atmosphere from zone 0.

To reduce risk of electrostatic discharge, housing (except free) must be covered with copper mesh and grounded.

MOUNTING

DO'S AND DON'TS

Mount the transducer so that it is *above the maximum material level by at least the blanking value*. Refer to the associated transceiver manual.

Do not mount the transducer directly to metal. Use a PVC coupling and nipple as provided.

Do not over tighten mounting. Hand tightening of the mounting hardware is sufficient.

On *liquid applications*, the transducer must be mounted so that the axis of transmission is perpendicular to the liquid surface. Avoid aiming into vortices.

On *solids applications*, the Milltronics Easy Aimer should be used to facilitate aiming of the transducer. Refer to the Easy Aimer instruction manual.

Where the transducer is mounted to a standpipe, the *inner standpipe surface and end must be smooth and free of burrs, ridges and seams*.

Consider the optional *temperature sensor* when mounting the transducer.

MOUNTING - LIQUID APPLICATIONS

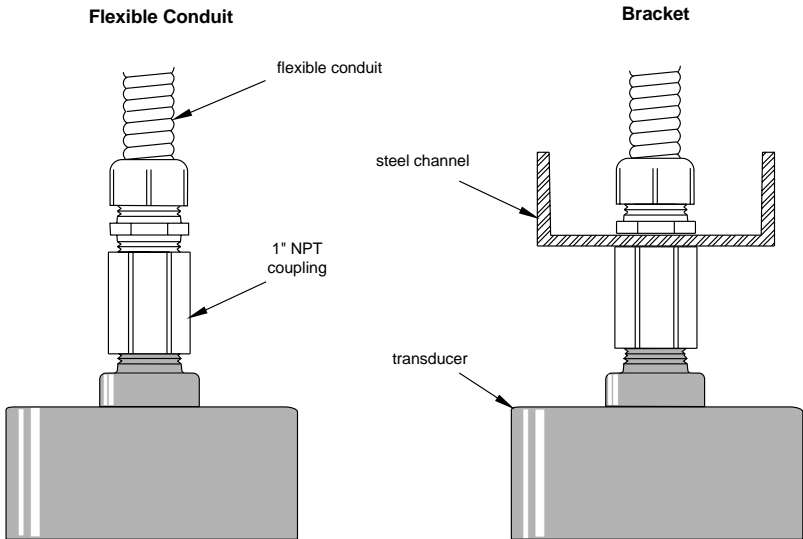

Flexible conduit mounted transducer should not be subjected to wind, vibration or jarring.

MOUNTING - LIQUID APPLICATIONS (cont'd)

Blind Flange

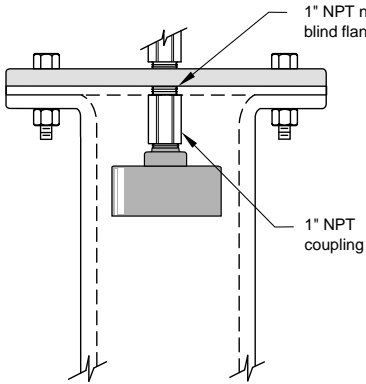

Flange, gasket and hardware supplied by customer. Refer to Liquid \ Applications - Standpipes.

Flanged

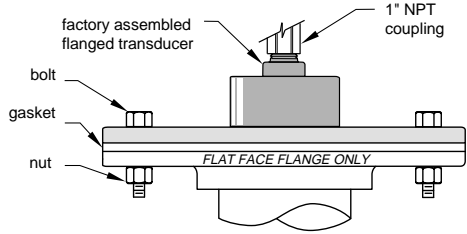

Customer flanged standpipe. If metal flange must be welded to pipe, refer to Liquid \ Applications - Standpipes.

MOUNTING - SOLIDS APPLICATIONS

Optional *Easy Aimer*

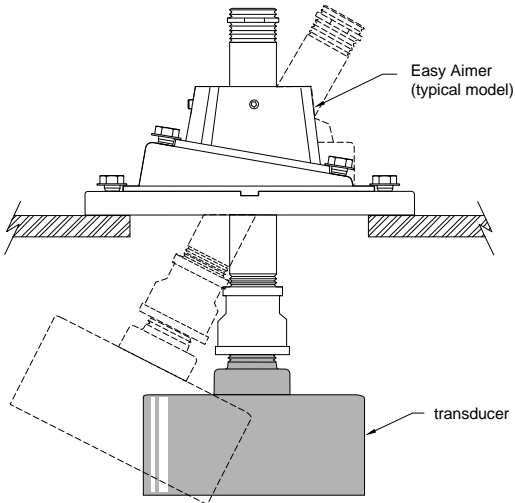

In solids applications, the transducer should be mounted so that it is aimed toward the low level draw point. To facilitate this mounting, it is suggested that the optional Milltronics *Easy Aimer* be used.

APPLICATIONS

The transducer is to be used only in the manner outlined in this instruction manual.

The transducer requires no cleaning or maintenance.

LIQUID APPLICATIONS - STANDPIPES

In many applications, access must be made via a standpipe. In such cases, Milltronics can provide flange mounted transducers that will readily mate to the flanged standpipe. Another option is to hang the transducer from a blind flange.

The standpipe length should be as short and the diameter as large as possible. As a rule of thumb, the -3 dB cone of the sound beam should not intersect the standpipe wall in applications opening into a vessel or larger area. Otherwise, additional blanking will be required to compensate for the interference zone created by the opening.

no additional blanking

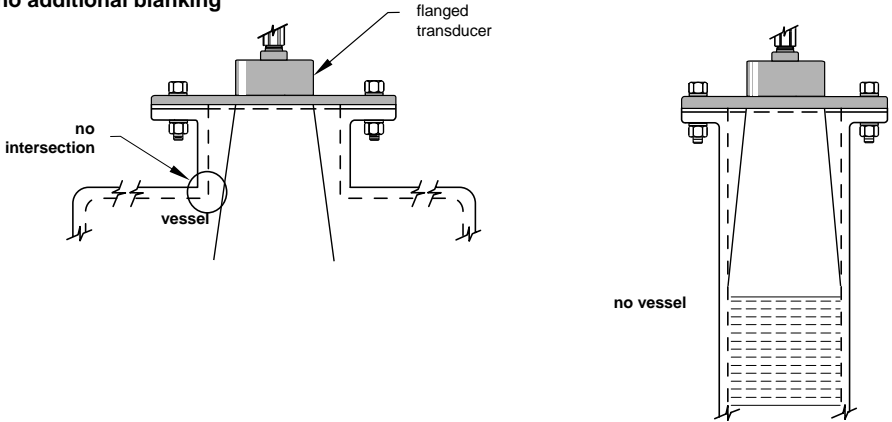

additional blanking

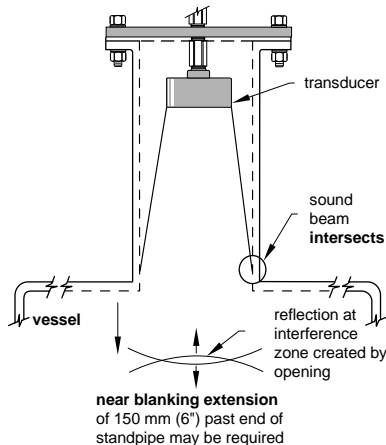

LIQUID APPLICATIONS - VOLUME

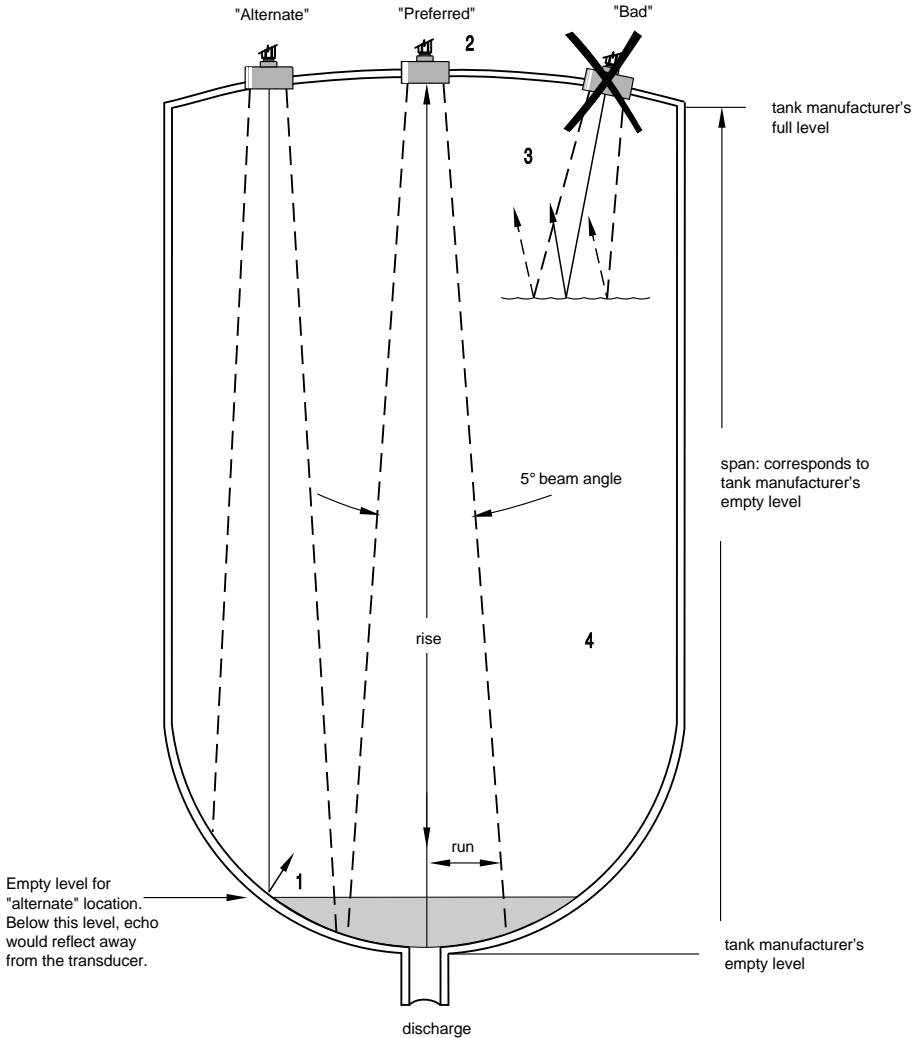

1. Beam should not detect bin bottom. If this occurs use range extension parameters (on transceivers where available) to omit false echoes. A 5° beam angle represents a rise : run of about 20 : 1. In most tanks, the transducer should be centered as much as possible (without interference from inlet) for optimum reading range.
2. Sound beam must be perpendicular to liquid surface.
If standpipe is used, refer to Liquid Applications - Standpipes.
3. Echo has missed improperly leveled transducer.
4. When performing an empty or full calibration, the tank must contain its normal vapour and be at its normal temperature.

SOLIDS APPLICATIONS - TYPICAL

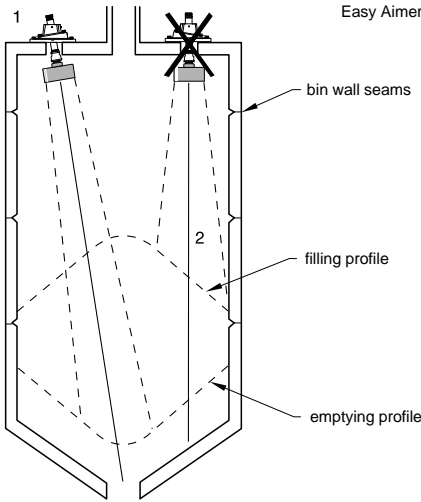

1. Transducer angled to avoid seams in bin wall and aimed at discharge in order to read bin when empty.
2. Avoid intersecting bin wall seams, structural members and wall irregularities. Otherwise, refer to transceiver manual.

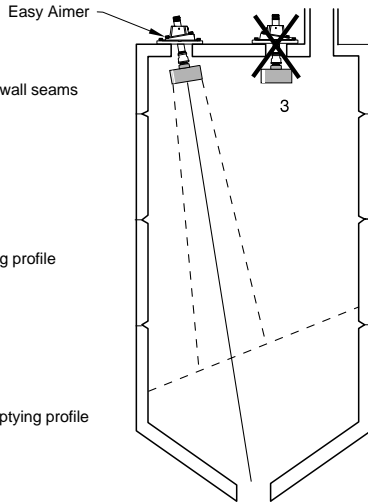

3. Transducer too close to material inlet. Falling material will intersect sound beam and cause erroneous readings or loss of echo.

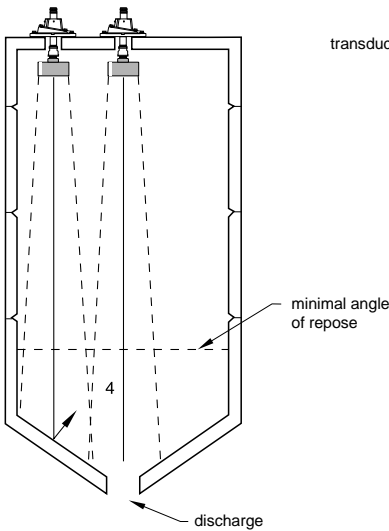

4. On fluid like solids, aim transducer perpendicular to material surface.

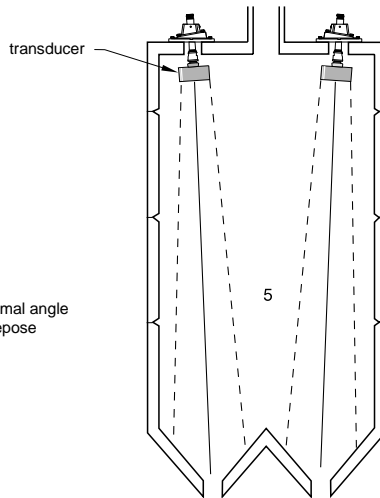

5. On dual discharge bins, aim each transducer at the discharge point.

SOLIDS APPLICATIONS - SPECIAL

STORAGE BIN WITH AGITATOR

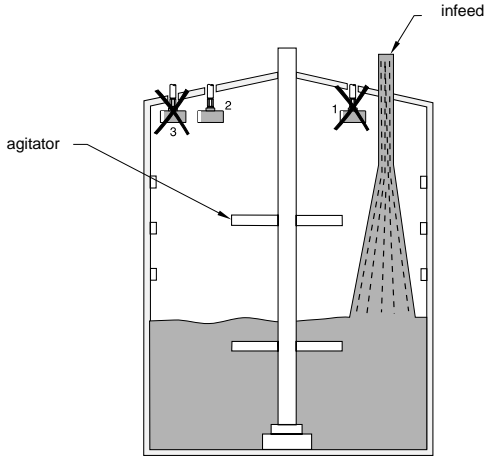

1. Transducer should be kept away from infeed.
2. Where agitators are in use, use the Agitator Discrimination parameter on transceivers where available.
3. Transducer should be aimed away from wall projections.

DRYER - WOOD CHIPS

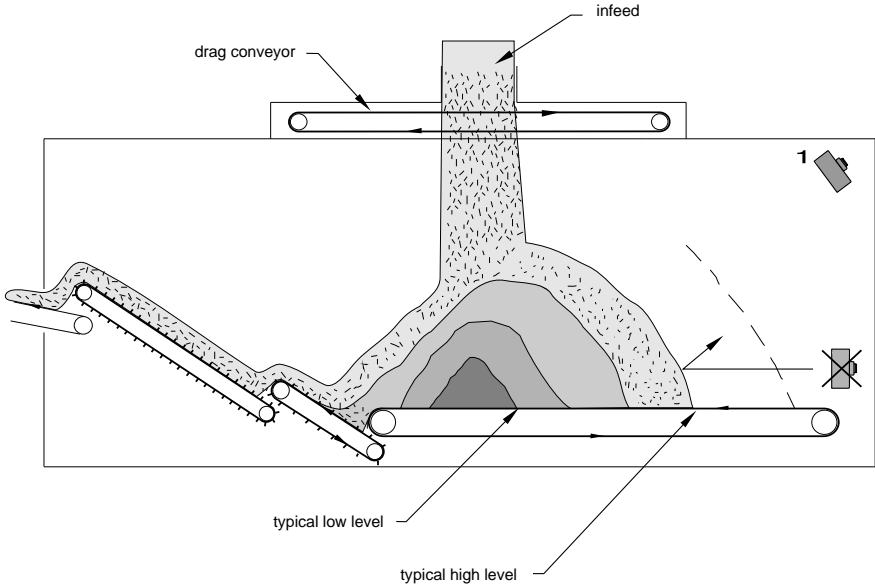

1. Transducer should be mounted perpendicular to slope of wood chips.