

SIEMENS

SIMATIC TI505

Smart Slice Discrete I/O Module

User Manual

Order Number: PPX:505-8105-2
Manual Assembly Number: 2586546-0063
Second Edition

**Copyright 1993 by Siemens Industrial Automation, Inc.
All Rights Reserved — Printed in USA**

Reproduction, transmission or use of this document or contents is not permitted without express consent of Siemens Industrial Automation, Inc. All rights, including rights created by patent grant or registration of a utility model or design, are reserved.

Since Siemens Industrial Automation, Inc. does not possess full access to data concerning all of the uses and applications of customer's products, we do not assume responsibility either for customer product design or for any infringements of patents or rights of others which may result from our assistance.

Technical data is subject to change.

We check the contents of every manual for accuracy at the time it is approved for printing; however, there may be undetected errors. Any errors found will be corrected in subsequent editions. Any suggestions for improvement are welcomed.

MANUAL PUBLICATION HISTORY

SIMATIC TI505 Smart Slice Discrete I/O Module User Manual

Order Manual Number: PPX:505-8105-2

Refer to this history in all correspondence and/or discussion about this manual.

Event	Date	Description
Original Issue	02/93	Original Issue (2591744-0001)
Second Edition	08/93	Second Edition (2591744-0002)

LIST OF EFFECTIVE PAGES

Pages	Description	Pages	Description
Cover/Copyright	Second		
History/Effective Pages	Second		
iii — vii	Second		
1-1 — 1-2	Second		
2-1 — 2-7	Second		
3-1 — 3-3	Second		
4-1 — 4-3	Second		
A-1 — A-2	Second		
Registration	Second		

Contents

Preface

Chapter 1 Product Overview

1.1	Features	1-2
-----	----------------	-----

Chapter 2 Installing the Module

2.1	Overview of Installation	2-2
	Flow of Tasks	2-2
	Visual Inspection	2-2
	Setting the Address Switch	2-2
2.2	Field Wiring Guidelines	2-3
	Avoiding Noise	2-3
2.3	Terminal Block	2-4
	Power	2-4
	Outputs	2-4
	Inputs	2-4
	Communication	2-5
2.4	Mounting the Module	2-6
	Mounting Tabs	2-6
	Clearance for Cooling	2-6
2.5	Communications Cable Configuration	2-7
	Installing Terminating Resistors	2-7
	Connecting the Trunk	2-7

Chapter 3 Programming and Assigning I/O Points

3.1	Programming the Controller	3-2
3.2	Logging the Module into the Controller	3-3
	Selecting the I/O Definition Chart	3-3
	Viewing the I/O Configuration Chart	3-3

Chapter 4 Troubleshooting

4.1	Status Indicators	4-2
	Module Status Indicators	4-2
	I/O Status Indicators	4-2
4.2	Replacing the Fuse	4-3

Appendix A	Specifications	A-1
-------------------	-----------------------------	------------

List of Figures

1-1	SIMATIC TI505 Smart Slice I/O Module	1-2
2-1	Flowchart of Installation	2-2
2-2	Output Wiring	2-4
2-3	Input Wiring	2-5
2-4	Terminal Block	2-5
2-5	Mounting Tabs and Dimensions	2-6
2-6	Communications Cable Configuration	2-7
3-1	Sample I/O Definition Chart	3-3
3-2	I/O Configuration Chart	3-3
A-1	Derating for Both Models	A-2

List of Tables

3-1	I/O Configuration	3-2
3-2	Addressing Example	3-2
A-1	Electrical Specifications	A-1
A-2	Environmental Specifications	A-2

Preface

This manual contains instructions for installing, wiring, and operating the SIMATIC® TI505™ Smart Slice Discrete Input/Output (I/O) Module. The module operates with either the SIMATIC® TI560T™/TI565T™ or the SIMATIC® TI545™ Programmable Controller.

References

Refer to the following manuals for instructions on installing, programming, and troubleshooting your Series 505™ equipment.

- *SIMATIC TI545 System Manual*
(PPX:545-8101-x)
- *SIMATIC TI560T/TI565T System Manual*
(PPX:560/565-8105-x)
- *SIMATIC® TI505/TI500™ Programming Reference Manual*
(PPX:505-8104-x)
- *SIMATIC® TI505 TISOFT™ User Manual*
(PPX:TS505-8101-x)

Agency Approvals

The Series 505 Smart Slice Discrete I/O module meets the standards of the following regulatory agencies.

- Underwriters Laboratories: UL® Listed (Industrial Control Equipment)
- Canadian Standards Association: CSA® Certified (Process Control Equipment)
- Factory Mutual Approved: Class I, Div 2 Hazardous Locations

Series 505 products have been developed with consideration of the draft standard of the International Electrotechnical Commission Committee proposed standard (IEC-65A/WG6) for programmable controllers. Contact Siemens Industrial Automation, Inc., for a listing of the standards to which Series 505 complies.

Telephoning for Assistance

If you need information that is not included in this manual, or if you have problems using the SIMATIC TI505 Smart Slice, contact your Siemens Industrial Automation, Inc. distributor or sales office. If you need assistance in contacting your U.S. sales office, call 1-800-964-4114.

Chapter 1
Product Overview

1.1 Features 1-2

1.1 Features

The SIMATIC TI505 Smart Slice I/O module (shown in Figure 1-1) allows access to input and output points that are not located near a TI500/TI505 base. The module attaches directly to the RS-485 remote I/O link and emulates a remote base. The module has ten inputs and six outputs. Power is derived from field excitation voltage. The PPX:505-9201 operates on 24 VDC; the PPX:505-9202 operates on 110 VAC. See Appendix A for the voltages supported.

Two terminals are provided on a removable connector for each I/O point to eliminate the need for a terminal strip. The sinking inputs have a high-side (line or positive) terminal and the sourcing outputs have a low-side (neutral or negative) terminal. A single replaceable fuse protects all the inputs and outputs. Status indicators are provided for each I/O point, the fuse, remote I/O communications, and module power.

The module appears to the controller as a high-density, 16-point input, 8-point output module. See Chapter 3 for a configuration example.

The module is compatible with TI545 and TI560/TI565 Programmable Controllers (PLCs).

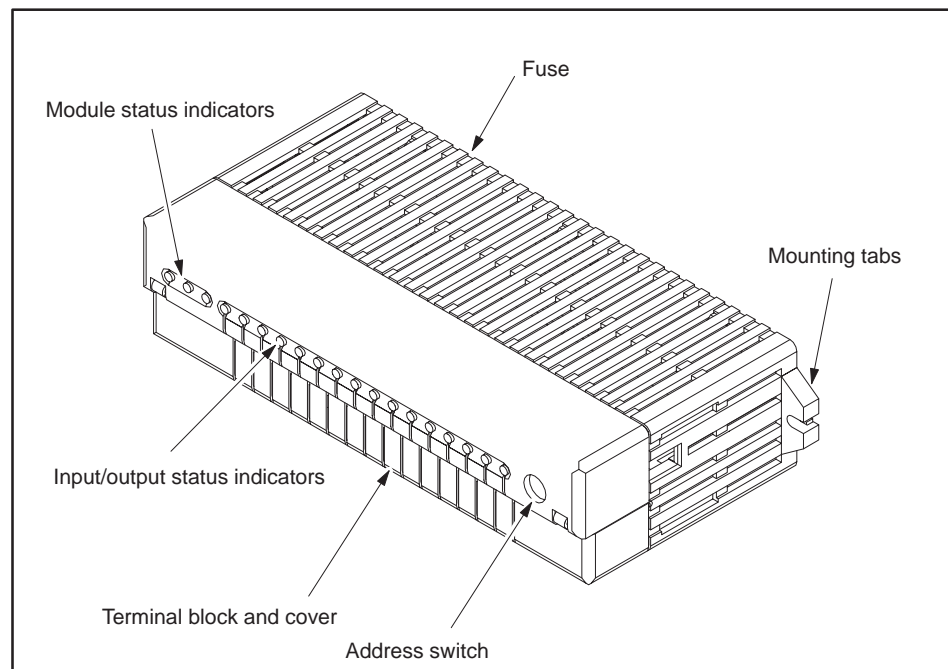

a000626

Figure 1-1 SIMATIC TI505 Smart Slice I/O Module

Chapter 2

Installing the Module

2.1	Overview of Installation	2-2
	Flow of Tasks	2-2
	Visual Inspection	2-2
	Setting the Address Switch	2-2
2.2	Field Wiring Guidelines	2-3
	Avoiding Noise	2-3
2.3	Terminal Block	2-4
	Power	2-4
	Outputs	2-4
	Inputs	2-4
	Communication	2-5
2.4	Mounting the Module	2-6
	Mounting Tabs	2-6
	Clearance for Cooling	2-6
2.5	Communications Cable Configuration	2-7
	Installing Terminating Resistors	2-7
	Connecting the Trunk	2-7

2.1 Overview of Installation

Flow of Tasks

Figure 2-1 shows the organization of the tasks described in this chapter.

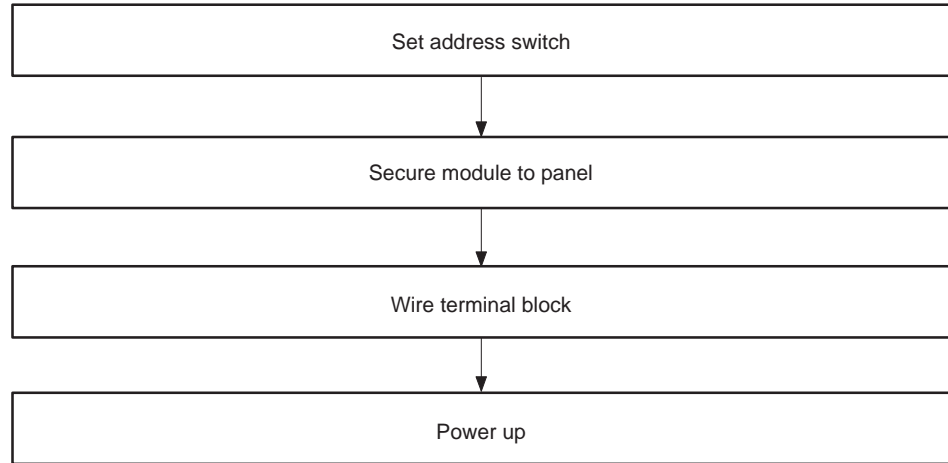

Figure 2-1 Flowchart of Installation

Visual Inspection

If there is any visible damage to the module, contact your Siemens Industrial Automation, Inc. distributor or sales office. If you need assistance in contacting your U.S. sales office, call 1-800-964-4114.

Setting the Address Switch

Use the address switch to assign the address number to the unit for system identification. Each unit must have a unique address number. The switch is labeled 0 through F, hexadecimal. Therefore, a switch number of 5 equals address 5, and a switch number of E equals address 14. An address of 0 is valid only with the TI560/TI565 controller.

WARNING

To minimize the potential risk of injury to personnel or damage to the system, do not change the unit address switch while the system is operating. Unpredictable behavior may result.

2.2 Field Wiring Guidelines

WARNING

To minimize the potential risk of injury to personnel or damage to the system, use supply wires suitable for at least 75° C. Signal wiring connected to this module must be rated at least 300 V.

ATTENTION

Employer des fils d'alimentation pour au moins 75° C. Le câblage de signalisation raccorde dans cette boîte doit convenir pour une tension nominale d'au moins 300 V.

Avoiding Noise

To avoid noise problems, follow these guidelines when you install the module.

- Use the shortest possible wires.
- Avoid placing signal wires parallel to high-energy wires. If the two must meet, cross them at right angles.
- Avoid bending the wire into sharp angles.
- Use wireways for wire routing.
- When you use shielded wires, ground them only at the source end for better noise immunity.
- Place wires so that they do not interfere with existing wiring.

2.3 Terminal Block

The module is equipped with a 38-position, removable terminal block. All field wiring is connected to this terminal block. The terminal block accepts wires between 14 and 22 AWG.

The terminal block is covered with a hinged shroud, which has a terminal identification label on the inside. The terminal block is divided into four different sections: power, outputs, inputs, and communication. See Figure 2-4.

WARNING

To minimize the potential risk of injury to personnel or damage to the system, ensure that all user-supplied wiring is de-energized before attempting to connect to terminal block.

Power

The three leftmost terminals are dedicated to user-supplied power and ground. See Appendix A for the voltages supported.

Outputs

The output load terminals are labeled 1 through 6, while the output return terminals are labeled YC. All the output return terminals are low-side (neutral or negative) terminals, and are connected together inside the module as shown in Figure 2-2.

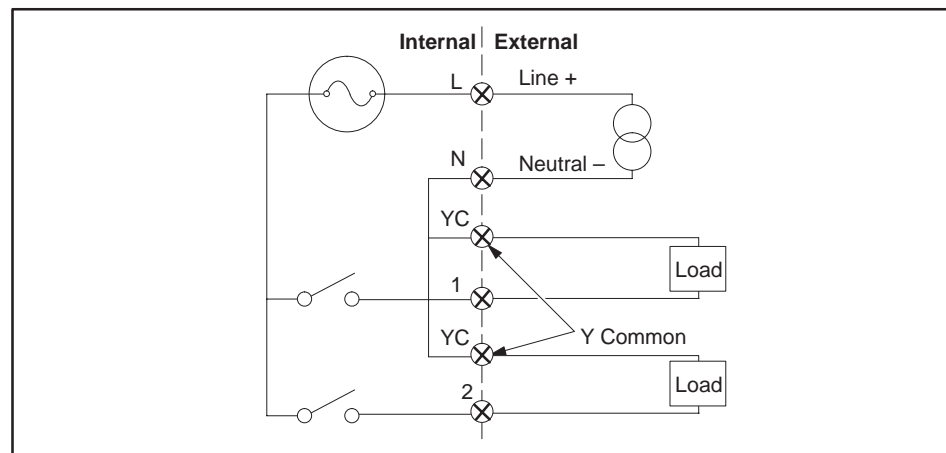

1003040

Figure 2-2 Output Wiring

Inputs

The input signal terminals are labeled 1 through 10, while the input source terminals are labeled XC. All the input source terminals are high-side (line or positive) terminals, and are connected together inside the module as shown in Figure 2-3.

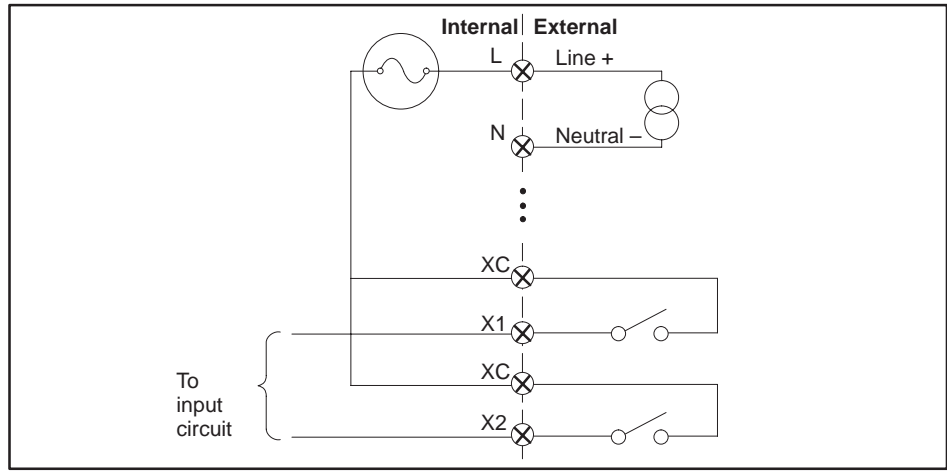

1003041

Figure 2-3 Input Wiring

Communication

The three right-most terminals are dedicated to the connection of the RS-485 communication cable that is connected to the system controller. Refer to Section 2.5 for communications cable configuration.

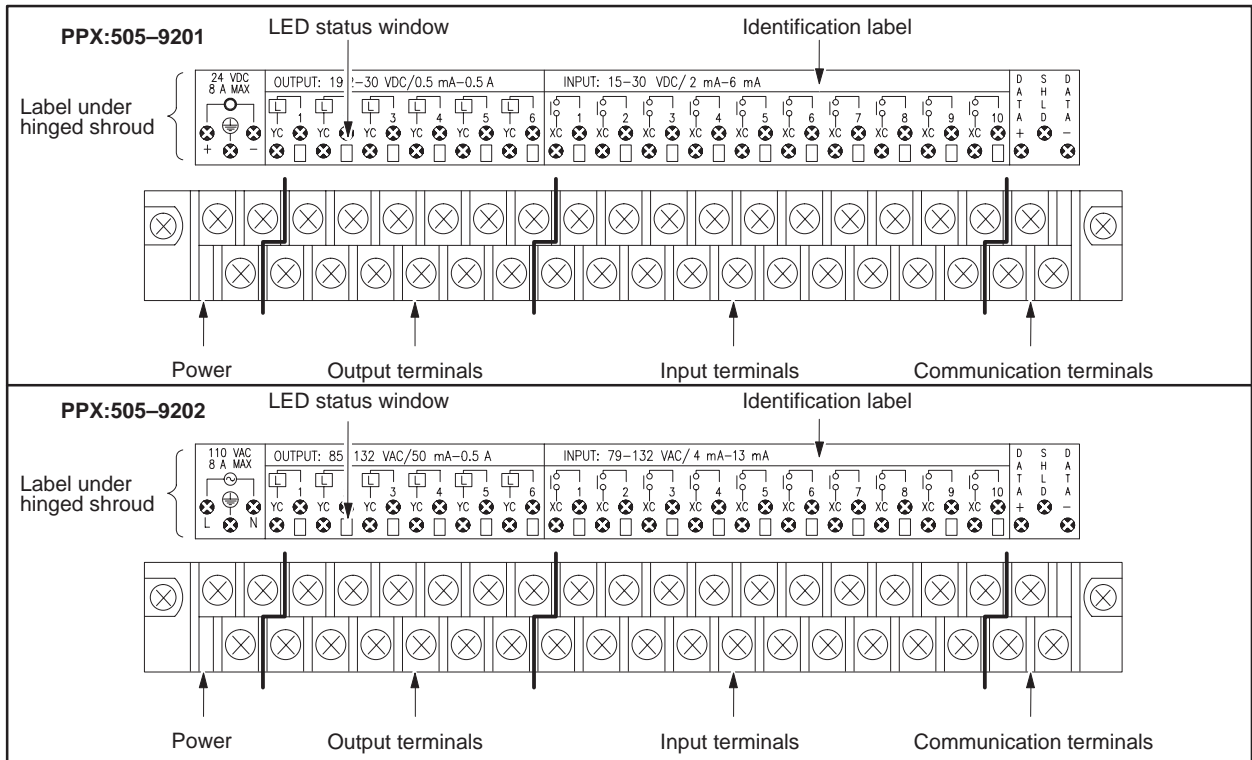

a000627

Figure 2-4 Terminal Block

2.4 Mounting the Module

Mounting Tabs

Use the mounting tabs to secure the module. The tabs accept #8-32 screws.

Clearance for Cooling

Allow one inch of space around the module to allow for sufficient air flow. Figure 2-5 shows mounting dimensions.

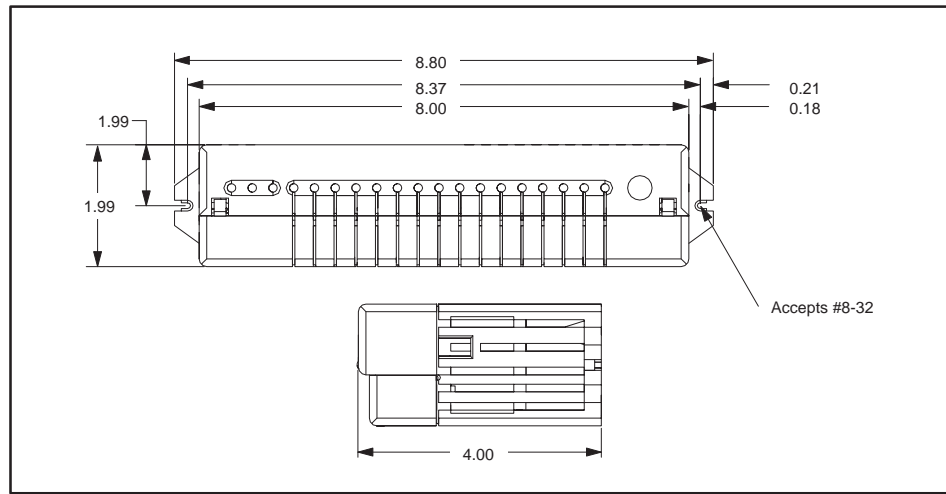

Figure 2-5 Mounting Tabs and Dimensions

2.5 Communications Cable Configuration

Installing Terminating Resistors

Install a terminating resistor across the DATA+ and DATA- terminals. If your application involves a series of Smart Slices, install a terminating resistor on the Smart Slice on the end. If your application uses only one Smart Slice, install a terminating resistor on that one. Refer to your controller user manual for cable installation guidelines and for the resistor values for your cable type.

Connecting the Trunk

You must connect the trunk directly to the Smart Slice. Do not use drop lines to connect to the Smart Slice. Refer to Figure 2-6.

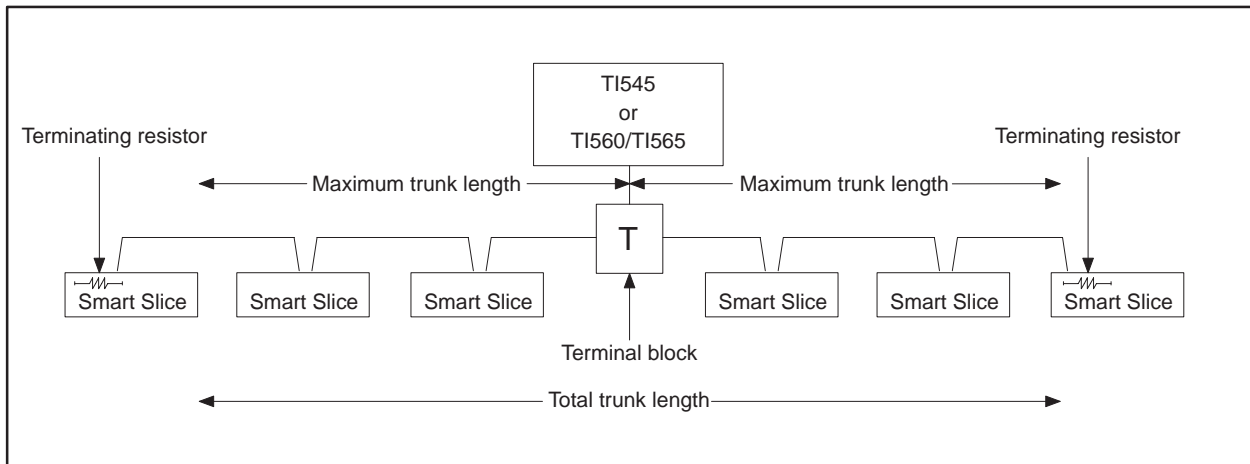

1002749

Figure 2-6 Communications Cable Configuration

Programming and Assigning I/O Points

3.1	Programming the Controller	3-2
3.2	Logging the Module into the Controller	3-3
	Selecting the I/O Definition Chart	3-3
	Viewing the I/O Configuration Chart	3-3

3.1 Programming the Controller

Refer to the program design manual for your controller for specific details on designing a program.

The Smart Slice appears to the controller as a high-density, 16-point input and 8-point output module as shown in Table 3-1. Since the Smart Slice has 10 inputs and 6 outputs, the balance of 6 input points and 2 output points are not used in the I/O configuration table.

Table 3-1 I/O Configuration

Density	Inputs	Outputs	I/O Points	Values
High	16	8	X1-10 X11-16 Y17-22 Y23-24	Input points 1-10 Not used Output points 1-6 Not used

Table 3-2 shows how the I/O address is determined for a module with the starting address of 81.

Table 3-2 Addressing Example

Program Input Address	Corresponding Module Input Address	Program Output Address	Corresponding Module Output Address
X81	X1	Y97	Y17
X82	X2	Y98	Y18
X83	X3	Y99	Y19
X84	X4	Y100	Y20
X85	X5	Y101	Y21
X86	X6	Y102	Y22
X87	X7		
X88	X8		
X89	X9		
X90	X10		

3.2 Logging the Module into the Controller

Selecting the I/O Definition Chart

Figure 3-1 shows a sample I/O definition chart with a module designated with address 01. Refer to your TISOFT manual for detailed instructions.

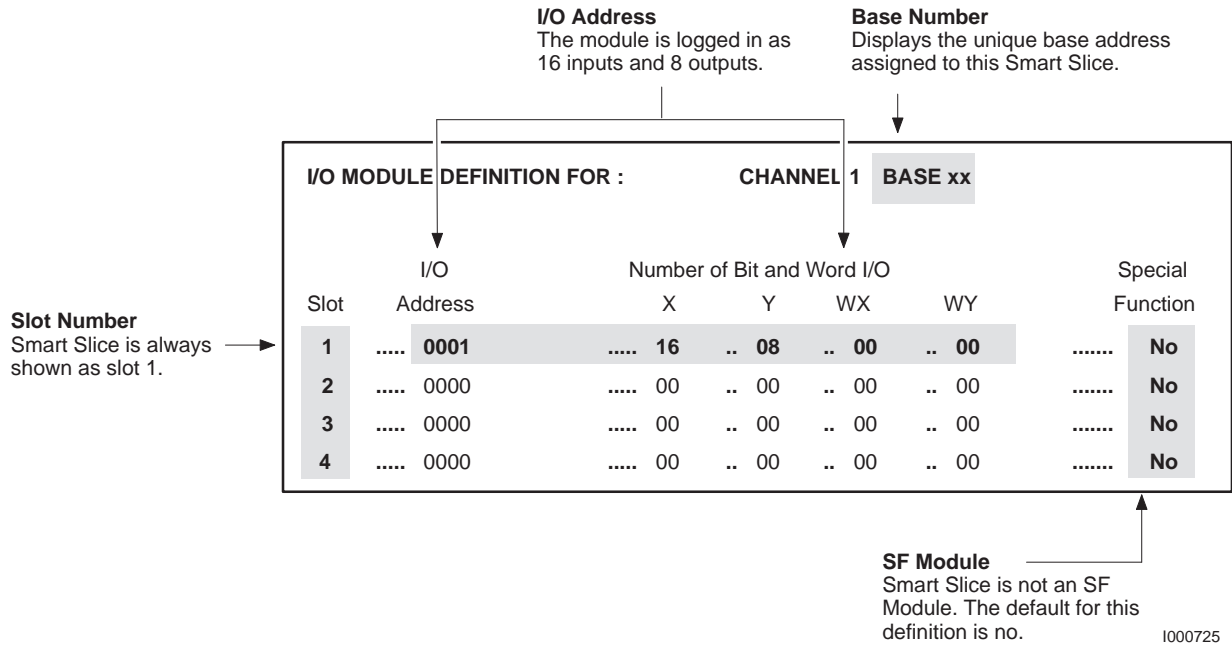

Figure 3-1 Sample I/O Definition Chart

Viewing the I/O Configuration Chart

Use SHOW or a similar menu selection to display the I/O Configuration Chart. The configuration in Figure 3-1 appears as shown in Figure 3-2.

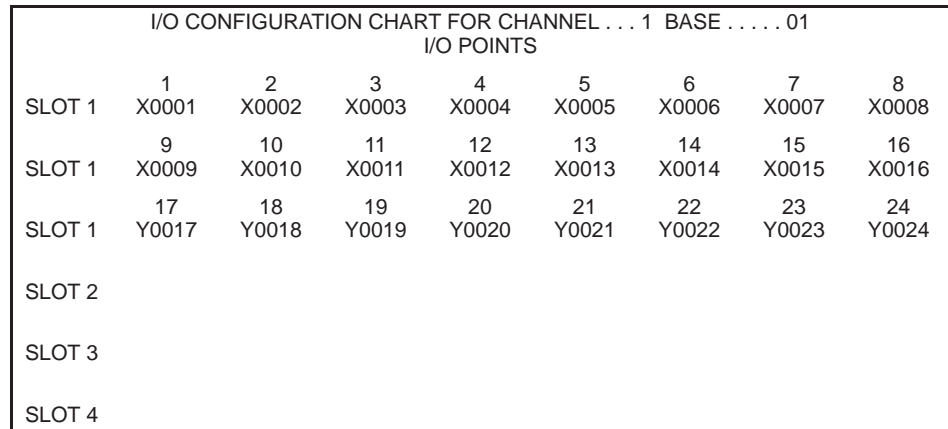

Figure 3-2 I/O Configuration Chart

Chapter 4

Troubleshooting

4.1	Status Indicators	4-2
	Module Status Indicators	4-2
	I/O Status Indicators	4-2
4.2	Replacing the Fuse	4-3

4.1 Status Indicators

Module Status Indicators

The MOD GOOD indicator turns on when the module is receiving the correct power.

The COM OK indicator has three modes of operation. When the LED is not on, this indicates that the communication cable is not installed properly or that the controller is not functioning properly. When the LED is blinking, it indicates that the module is not configured properly in the controller. When the LED remains on, this indicates that communication is occurring and that the unit is configured properly.

The FUSE indicator turns on when the fuse is blown. You also can determine the status of the fuses by using RLL to check the module fail bit in the controller. (See your SIMATIC TI505 Programmable Controller manual.)

I/O Status Indicators

There are six output status LEDs. The output status indicators show the status of the output points. When an output point is on, the corresponding LED lights. The output indicators show the status from the logic (controller) side, not the field side.

There are ten input status LEDs. The input status indicators show the status of the input points. When an input point is on, the corresponding LED lights. The input indicators show status from the field side, not the logic (controller) side.

4.2 Replacing the Fuse

WARNING

To minimize the potential risk of injury to personnel or damage to the system, ensure that all user-supplied power is disconnected from the module before attempting the replace the fuse.

The fuse is located in the rear of the module, through an access opening. Use an 8 A, 250 VAC 5 × 20 mm normal-blow replacement fuse. Replace the fuse only when the FUSE indicator is on.

Appendix A

Specifications

Table A-1 Electrical Specifications

Specification	PPX:505-9201	PPX:505-9202
Description	24 VDC, 10 inputs/6 outputs	110 VAC, 10 inputs/6 outputs
Rated voltage	20–30 VDC	90–132 VAC, 47–63 Hz
Input type	Sinking, high-side common	Sinking, high-side common
Input on voltage range	15 VDC min, 30 VDC max	79 VAC min, 132 VAC max
Input on current range	2.0 mA min, 6.0 mA max	4.0 mA min, 13.0 mA max
Input off voltage range	0.0 VDC min, 5.0 VDC max	0.0 VAC min, 20.0 VAC max
Input off current range	0.5 mA max	1.0 mA max
Input delay time	2 ms max	6 ms min, 40 ms max
Output type	Sourcing, low-side common	Sourcing, low-side common
Output current	0.5 A max at 60°C, 1.0 A max at 40°C	0.5 A max at 60°C, 1.0 A max at 40°C
Output temporary overload	3.0 A for 1 ms	5.0 A rms for 2 cycles
Output DV/DT	—	300 V/μs
Output on voltage drop	1.0 VDC	1.4 Vrms at 1.0 A
Output off leakage current	0.02 mA max	2.0 mA max
Output delay time	4.0 ms on-to-off, 2.0 ms off-to-on	11 ms on-to-off, 2.0 ms off-to-on

Table A-2 Environmental Specifications

Wire gauge	14–22 AWG
Spade lug for use with connector	Amp part number 321462
Ring lug for use with connector	Amp part number 327891
Operating temperature	0 to 60°C (32 to 140°F)
Storage temperature	–40 to +70°C (–40 to 158°F)
Relative humidity	5% to 95% noncondensing
Pollution degree	2, IEC 664, 664 A
Vibration	Sinusoidal IEC 68-2-6, Test Fc 0.15 mm peak-to-peak, 10–57 Hz; 1.0 g, 57–150 Hz Random IEC 68-2-34, Test Fdc, equivalent to NAVMAT P–9492 0.04 g ² /Hz, 80–350 Hz
Electrostatic discharge	IEC 801, Part 2, Level 4, (15 kV)
Shock	IEC 68-2-27; Test Ea
Noise immunity, conducted	IEC 801, Part 4, Level 3
Noise immunity on user power lines	MIL STD 461B, CS01, CS02, CS06, IEC 255-4, IEEE 472
Noise immunity, radiated	IEC 801, Part 3, Level 3, MIL STD 461B, RS01, RS02, RS03
Corrosion protection	All parts of corrosion-resistant material or plated or painted as corrosion protection

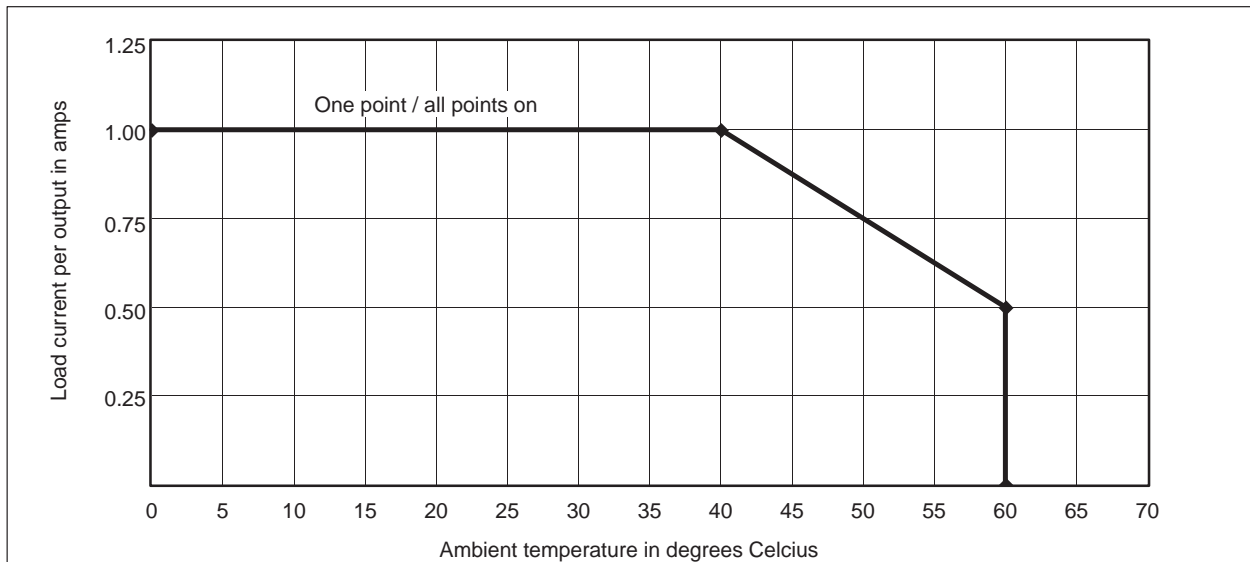

1002750

Figure A-1 Derating for Both Models

SIMATIC is a trademark of Siemens AG.

Series 505 and TISOFT are trademarks of Siemens Industrial Automation, Inc.

TI500, TI505, TI545, TI560T and TI565T are trademarks of Texas Instruments Incorporated.

UL is a registered trademark of Underwriters Laboratories, Inc.

CSA is a registered trademark of Canadian Standards Association

Customer Registration

We would like to know what you think about our user manuals so that we can serve you better.
How would you rate the quality of our manuals?

	Excellent	Good	Fair	Poor
Accuracy	_____	_____	_____	_____
Organization	_____	_____	_____	_____
Clarity	_____	_____	_____	_____
Completeness	_____	_____	_____	_____
Overall design	_____	_____	_____	_____
Size	_____	_____	_____	_____
Index	_____	_____	_____	_____

Would you be interested in giving us more detailed comments about our manuals?

Yes! Please send me a questionnaire.

No. Thanks anyway.

Your Name: _____

Title: _____

Telephone Number: (____) _____

Company Name: _____

Company Address: _____

Manual Name: SIMATIC TI505 Smart Slice Discrete I/O Module User Manual

Edition: Second

Manual Assembly Number: 2586546-0063

Date: 08/93

Order Number: PPX:505-8105-2

FOLD

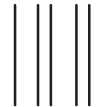

NO POSTAGE
NECESSARY
IF MAILED
IN THE
UNITED STATES

BUSINESS REPLY MAIL

FIRST CLASS

PERMIT NO.3

JOHNSON CITY, TN

POSTAGE WILL BE PAID BY ADDRESSEE

ATTN: Technical Communications M/S 3519
SIEMENS INDUSTRIAL AUTOMATION INC.
3000 BILL GARLAND RD
P O BOX 1255
JOHNSON CITY TN 37605-1255

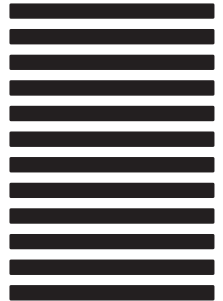

FOLD